

UNIV. OF
TORONTO
LIBRARY

BONDING LIST JUL 1 1922

Digitized by the Internet Archive
in 2008 with funding from
Microsoft Corporation

CANADIAN MACHINERY

AND MANUFACTURING NEWS

A weekly newspaper devoted to the machinery and manufacturing interests.

Vol. XVII.

TORONTO, JANUARY 4, 1917

No. 27

EDITORIAL CONTENTS

Specification Requirements of Munitions Material	1-2
General	2-3
Canadian Iron and Steel Production.	
Pressure Oil Film Lubrication	3-6
Canadian Machine Tool Industry on Sound Basis	6-7
High School of Commerce, Toronto	7-8
General	8
Toronto Union Station.	
Editorial Correspondence	9-12
Line Shaft Trouble....Jig for Drilling Sextants....Why They Failed....The Value of Brains....	
Cutting Diametral Pitch Worms.	
General	12
Building Trades Activity Throughout the Dominion....Canadian Power Production.	
Spokes in Industry's Wheel	13-14
Thomas Baird Reid.	
General	14
Industrial Development of Hamilton, Ont., During 1916....Ontario Boiler Rules Revision....Mag-	
netic Indicator for Critical Temperatures.	
Progress in New Equipment	15-16
Fuse Graduating Machine....Formed Cutter Relieving Machine....Traversing Head Drill Press	
....New Line of Radial Drills.	
General	16
C.P.R. Tunnel Through Selkirk.	
Editorial	17
Our 1917 Munitions Opportunities....Canada's National Service Week.	
Selected Market Quotations	18-19
The General Market Conditions and Tendencies	19-20
Montreal Letter....Toronto Letter.	
Industrial and Construction News (Advtg. Section)	60-61

THE MACLEAN PUBLISHING COMPANY, LIMITED

JOHN BAYNE MACLEAN, Pres. H. T. HUNTER, Vice-pres. H. V. TYRRELL, Gen. Man.

Publishers of Hardware and Metal, The Financial Post, MacLean's Magazine, Farmer's Magazine, Canadian Grocer, Dry Goods Review, Men's Wear Review, Printer and Publisher, Bookseller and Stationer, Canadian Machinery and Manufacturing News, The Power House, The Sanitary Engineer, Canadian Foundryman, Marine Engineering of Canada

Cable Address: Macpubco, Toronto; Atabek, London, Eng.

CANADIAN MACHINERY AND MANUFACTURING NEWS

PETER BAIN, M.E., Editor. B. G. NEWTON, Manager.
Associate Editors: A. G. WEBSTER, J. M. WILSON, J. H. RODGERS.
CHIEF OFFICES:

CANADA—Montreal, 701-702 Eastern Townships Building, Telephone Main 1001. Toronto, 143-153 University Ave., Telephone Main 7324. Winnipeg, 22 Royal Bank Building, Telephone Garry 2313.

GREAT BRITAIN—LONDON, The MacLean Company of Great Britain, Limited, 88 Fleet Street, E.C., E. J. Dodd, Director, Telephone Central 129600. Cable Address: Atabek, London, England.

UNITED STATES—New York, R. B. Huettli, 115 Broadway, N.Y., Telephone Rector 8971; Boston, C. L. Morton, Room, 733, Old South Building, Telephone Main 1024. A. H. Byrne, 1104-5-6-7 Fort Dearborn Bldg., 105 W. Monroe St., Chicago, Telephone Radolph 3231.

SUBSCRIPTION PRICE—Canada, Great Britain, South Africa and the West Indies, \$3.00 a year; United States, \$2.50 a year; other countries, \$4.00 a year; Single Copies, 15 cents. Invariably in advance.

173 142
4 18/22

HENDEY 18-Inch GEARED HEAD LATHE

8 mechanical changes of speed for spindle with driving shaft running at constant speed, 4 direct and 4 through back gears.

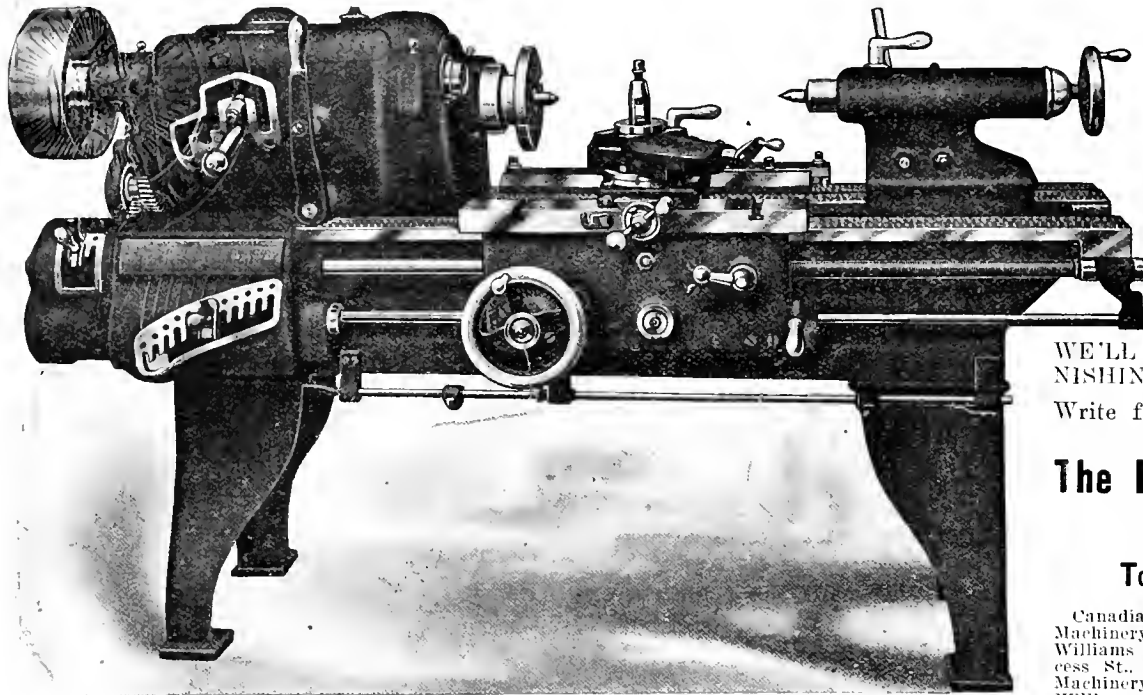

36 DIFFERENT THREADS AND FEEDS are had through Mounted Change Gearing, each change being quickly made through controlling handles in Gear Boxes. BEFORE PURCHASING A NEW LATHE INVESTIGATE THE HENDEY SERVICE.

WE'LL HELP YOU BY FURNISHING LIST OF USERS. Write for descriptive circular.

The Hendey Machine Company

Torrington, Conn.

Canadian Agents: A. R. Williams Machinery Co., Toronto, Ont.; A. R. Williams Machinery Co., 260 Princess St., Winnipeg; A. R. Williams Machinery Co., Vancouver; A. R. Williams Machinery Co., St. John, N.B.; Williams & Wilson, Montreal.

INDEX TO ADVERTISERS

A	E	L	R
Aeroplane Products, Ltd. 80	Eastern Machine Screw Corp. 24	L'Air Liquide Society 89	Racine Tool & Machine Co. 23
Anderson, H. N. 32	Elmes Eng. Works, Charles F. 16	Lancashire Dynamo Co. 89	Stout & Maybee 64
Armstrong Bros. Tool Co. 78	Eric Foundry Co. 96	Laudis Machine Co. 81	Riverside Mach. Co. 68
Armstrong, Whitworth, of Canada. 8		Lymburner, Ltd. 28	Rokwell Co., W. S. 78
Atkins Steel Co., Wm. 9			Rocheford Mach. & Tool Co. 11
Atlas Crucible Steel Co. 8			Roper, C. F., Co. 28
Atlas Press Co. 78			
B	F	M	S
Baldock & Sons 84	Fetherstonhaugh & Co. 64	MacKinnon, Holmes & Co. 64	Shuster Co., P. B. 79
Baird Machine Co. 69	Fitzgerald, W. H. J. 69	Main Belting Co. 59	Simmons Mach. Co. 70 and 83
Banfield, E. J. 12	Foss & Hill Machy. Co. 62	Manufacturers Equipment Co. 15	Skinner Chuck Co. 77
Banfield & Sons, W. H. 62	Inside back cover	Marsh & Henthorn 80	Slocum, Avram & Slocum 72
Barnes, Wallace, Co. 62	Founhy & Mach. Co. 62	Mathews, Jas. H., & Co. 48	Smalley General Co., Inc. 20
Beaudry & Co. 79		T. McAvity 68	Smith Co., H. A. 71
Bertram, John, & Sons Co. 1	G	McBoys Brandt Machy. Co. 49	Spartett Co., L. S. 75
Biggs-Watterson Co., The 67	Gardner Machine Co. 19	McBoysky Reamer Co. 30	Steel Bending Brake Works, Ltd., The 78
Blake & Johnson Co., The 18	Gatlock-Walker Machy. Co. 20	McGougal Co., R. Inside back cover	Steel Co. of Canada 3
Blount Co., J. G. 15	Garvin Machine Co. 12	McKay Co., James 78	Stenotype Co. 74
Bradford Oven & Rack Co. 63	Geometric Tool Co. 29	McLaren Belting Co., J. C. 22	Steinle Tarret Mach. Co. 21
Bridgford Mach. Tool Wks. 5	Gooley & Edlund Co. 67	Mechanical Engineering Co. 22	Stoptoe Co., John 65
Bristol Co. 77	Grant Gear Works, Inc. 81	Metals Coating Co. 83	Stocker, H. A., Machy. Co. 71
Brownell Machy. Co. 69	Grant Mfg. & Machine Co. 52	Metalwood Mfg. Co. 91	Stow Mfg. Co. 24
Burden Hanbury, A. 61	Greenfield Mach. Co. 76	Milbolland Mach. Co. 14	Strong & Hery Co. 68
		Modern Tool Co. 25	Swedish Gage Co. 13
C	H	Montreal Machy. & Supplies, Ltd. 65	Swedish Steel & Importing Co. 13
Canada Machinery Corp. 5	Hamilton Mach. Tool Co. 17	Morse Twist Drill Co. 83	
Outside back cover	Hamilton Gear & Machine Co. 24	Morton Mfg. Co. 62	T
Can. Desmond-Stephan Mfg. Co. 93	Hammant Car & Engr. Co. 62	Motch & Merryweather 70	Tabor Instrument Co. 93
Can. Economic Lubricant Co. 29	Hanna & Co., M. A. 13	Murphy Machine & Tool Co. 26	Tabor Mfg. Co. 78
Can. Fairbanks-Morse Co. 78	Hawkrige Brothers Co. 61		Tabor Instrument Co. 93
Can. Ingersoll Rand 91	Hendey Machine Co. 95	N	Tavani Electric Steel Co. 77
Can. Inspection & Testing Laboratories, Ltd. 77	Hepburn, John T., Ltd. 73	National Machine Tool Co. 81	Toomey, Frank, Inc. 70
Can. Matthews Gravity Co. 63	High Speed Hammer Co. 72	New Britain Machine Co. 35	Toronto Iron Works 77
Can. Metal Products Co. 79	Himoff Mach. Co. 74	New York Machy. Exchange. 76	Toronto Testing Laboratory 80
Can. B. K. Murton Co. 33	Hull Iron & Steel Foundries 18	Nicholson File Co. 34	Toronto Type Foundry 65
Can. Steel Foundries, Ltd. 7	Hurlbut Rogers Machy. Co. 89	Niles-Bement-Pond Inside front cover	
Carborundum Co. 78	Hyde Engineering Works 26	Northern Crane Works 77	U
Chapman Double Ball Bearing Co. 24		Norton, A. O. 81	United States Electrical Tool Co. 87
Cincinnati Lubricant Pump Co. 72	I	Norton Company 36	
Cincinnati Puller Mach. Co. 18	Ideal Tool & Mfg. Co. 24	Nova Scotia Steel & Coal Co. 6	V
Cleveland Milling Mach. Co. 27	Independent Pneumatic Tool Co. 87		Vanadium-Alloy Steel Co. 67
Cleveland Pneumatic Tool Co. 85	Industrial Works 68	O	Victor Tool Co. 24
Cleveland Twist Drill Co. 85	Iron Works, The 61	Oliver Machinery Co. 16	W
Clippner Belt Lacer Co. 29		Ontario Specialties, Limited. 79	Warner & Swasey Co. 23
Cook, Asa S., Co. 78	J	Oven Equipment & Mfg. Co. 89	Wells Bros. of Canada, Ltd. 37
Cullen Mech. Co., C. E. 68	Jacobs Mfg. Co. 59		Whiting Foundry Equipment Co. 72
Cushman Chuck Co. 77	Jencks Machine Co. Front cover	P	Whitney Mfg. Co. 74
	Jersey City Machine Co. 79	Parmenter & Bulloch Co. 81	Wickes Brothers 14
D	Jones & Glasco 29	Peerless Mach. Co. 23	Williams, J. H., & Co. 93
Davis, W. F., Machine Tool Co. 71	Johnson Mach. Co., Carlyle 31	Petrie, D. W. 67	Williams Machy. Co., A. R. 59 and 7
Deloro Smelting & Refining Co. 4		Positive Clutch & Pulley Works. 80	Williams & Wilson 68
Dominion Forge & Stamping 89	K	Pratt & Whitney Co. Inside front cover	Winsor Mach. Co. 63
Dominion Steel Foundry Co. 79	Kennedy, Wm., & Sons 10	Pringle, R. E. T. 37	Winnipeg Gear & Engr. Co. 79
Dunry, H. A., Co. 7	King, Ltd., Warden 12	Puro Sanitary Drinking Fountain Co. 61	Z
			Zenith Coal & Steel Products. 80

Specification Requirements of Munitions Material

By F. C. H.

One of the many beneficial results derived from the manufacture of munitions is the greatly increased appreciation, by engineering firms generally, of the benefits to be derived from judicious heat treatment of metals. In the automobile and steel making industries such procedure had been highly developed, but the applications of scientific thermal manipulations to every-day work had been more or less neglected. Future conditions may largely alter this state of affairs, so that heat-treating will ultimately assume its true position.

TO many of those engaged in the manufacture of munitions the reasons for accurate specifications with relation to metallurgy is not apparent. The common principles of heat treatment of carbon and alloy steels and non-ferrous metals are generally understood, yet there are many little points of interest and importance.

Large guns are made up of concentric wire-wound tubes of steel having the following composition:—

Condition of steel	El. limit lbs. per sq. in.	Tensile strength lbs. per sq. in.	Elongation in 2 in.	Carbon Manganese Chrome Vanadium			
				Carbon	Manganese	Chrome	Vanadium
Soft	35,400	78,800	24%	.40	.80
Hardened in oil, 1450° F. drawn		118,500	14%
800	63,900	102,040
Soft	41,000	83,700	35%	.30	.50	.90	.20
Hardened	39,020	132,000	30%
Soft	63,000	103,440	20%	.50	.30	1.00	.20
Hardened	170,000	190,000	15%

and being subjected to compressive stress, is also subject to tensile stress, due to the shrapnel bullets inside. In order that these bullets may be thrown forward the shell is designed with a thick wall at the base and this wall gradually tapers off to a thin point near the socket in nose. When the fuse explodes the charge, this thin wall bursts or spreads open, or the fuse threads are stripped. If the steel is too hard the shock of the explosion in the cartridge

000 lbs. per sq. in. Carbon steel of about 1.25 per cent. carbon was used for the first two sections, as the punches were built up of water quenched sections, heating to 1475 deg. F. and drawing at 430 deg. F. The remaining portion of punches was .90 to .95 per cent. carbon steel.

In determining the capacity of presses required, crushers of brass were made and tested on a Riehle 100-ton testing machine and from these results the power of presses required was calculated.

The pressures required for operations were:—

Cutting and drawing about 15,000 to 40,000 lbs.	
Tapering, 1st operation	8,000 lbs.
Tapering, 2nd operation	20,000 lbs.
Stripping after 1st oper.	3,000 lbs.
Stripping after 2nd oper.	11,000 lbs.
Stripping after heading	16,000 lbs.

Scleroscope Tests

Scleroscope tests were made from day to day on the material, and the results compared with analyses, the result being that only the raw material which came within the scleroscope hardness numbers of 20 and 25, was accepted and readings of either 15 or 30 caused rejections.

A test made on a cartridge case during and after every operation in manufacturing gave:—

Operation	Base	At 1/4"	At 2"	At 5"	At 10"
Disc	16				
Cup					
B	20-27	51	55		
A	19	21	21-23		
1st Draw:					
B	20	22	52-55	55-60	
A	19	20	19	23	19-23
2nd Draw:					
B	19	20	52	55	55
1st Indent:					
B	42	47	54-58	55	60
A	18	20	18-20	18	20
3rd Draw:					
B	20	21	51	55	60-65
A	18	19	18	19	18
4th Draw:					
B	18	20	43	50	55
2nd Indent:					
B	33	40	50	57	55
A	19	20	20	22	20
5th Draw:					
B	20	22	47	53	58
A	18	19	20	22	25
6th Draw:					
B	18	20	50	55	55
Heading operation:					
1	50	55			
2	51	58	52	58	65
3	50	58			
Send annealing			52	58	65
The Base:					
1	45	52	52	58	60
2	52	55			
3	48	55			
B	before annealing.				
A	after annealing.				

It is interesting to note the effect of annealing which is done at 1,200 deg. F. for 30 minutes, and to note how the

These tubes are necessarily put under compression so that when the cartridge is exploded, with subsequent stresses, the elastic limit will not be exceeded and a reasonable factor of safety allowed.

The chamber pressure on the 18-pdr., 3 in., 6 in., 8 in., and 9.2 in. guns is from 26,880 lbs. per sq. in. to 33,600 lbs. per sq. in., and on rifles it is a little higher, possibly 45,000 lbs. per sq. in.

On this necessary chamber pressure is based the calculations which determine the requirements of the specifications. In the case of high explosive shells at the moment of explosion of propelling charge, the inertia of shell results in a sudden compressive force being applied through the base and this force tends to bulge the walls of shell which will occur if the shells are soft. For this reason, after high explosive shells are forged they should be stood on end to cool and a reasonable distance apart instead of being piled. This piling of hot shells would cause them to be softened by annealing. As there is no subsequent heat treating for high explosive as compared with shrapnel, defects are not developed as when grinding the latter.

Base plates have a test piece taken across the grain as well as one with the grain. The piece taken across is a check to be sure the material is not pined or seamy, as these defects occur principally at the centre. These plates are subjected to the same strain as the shell and specifications are similar.

Shrapnel Design

The shrapnel shell, while opposing the bursting charge due to its own inertia

case will cause fracture with damage to the gun, and if the cartridge case is too hard, due to excessive zinc, permanent deformation will cause it to stick in the gun and prohibit its use over again after being refilled.

While specifications for shell steel have close limits, it should be possible to use steel of higher tensile strength but having good elongation. In this way it would be possible to use almost any analysis, getting the physical properties by heat treatment.

If the steel is hard and brittle, when the shell bursts the pieces break into many small parts, whereas, if the steel is tough, the pieces are larger and the edges are rougher, tending to tear instead of cut, thereby doing more damage.

Cartridge Case Requirements

If the brass cartridge cases vary much in the zinc content from 70 copper, 30 zinc, difficulties will be experienced in manufacture and the product will not permit of being loaded three times as specified.

Formerly, the French military specifications considered uniformity so important that they went so far as to specify where the spelter and copper should come from. The reason for this is doubtless the fact that the analysis must be correct to give a minimum of scrap during manufacture. The great loads to which this material is put during manufacture under 500 and 800 ton presses, for indenting and heading, necessitates punches made of the best of steel, capable of withstanding approximately 160,

hardness increases as the thickness of metal decreases.

If tensile test pieces are examined after being annealed at a high temperature, the surface is rough, showing the grain is too large and that there are cleavage cracks. Annealing at 750 deg. F. gives enlarged grain, and at 1380 deg. F. the grain size is about at the maximum allowable if the brass is to be of any commercial use.

The following table shows the physical properties for different annealing temperatures:—

Annealing temp. degs. Fahr.	Maximum	
	stress tons per sq. in.	Elongation in 2 in.
As rolled	25.00	15.5
545	28.50	20.0
662	26.20	30.0
932	18.20	51.0
1166	17.00	58.0
1256	16.50	58.0
1382	16.00	63.0
1475	15.00	59.0
1500	15.00	59.0
1650	14.00	53.0
1690	13.00	25.0

If brass is held too long at a temperature above 1,300 deg. F., the metal will be greatly weakened. The most important factor is to anneal at the lowest possible temperature necessary to get the desired results.

The fuse material required is most interesting, as the manufacture and loading of this piece is difficult and exacting. There are several grades of brass, each of which is to be used for specified purposes.

Metal and Purpose.	Yield lbs. per sq. inch	Breaking Load, lbs. per sq. inch	Elongation in 2 inches and 1/2 inch dia.	Copper	Zinc	Lead
Delta Metal—Time and percussion pellets and screw plugs	44,800	67,200	20	64.74	24.11	1.00
Hard Rolled Brass—Stirrup springs	13,440	26,880	10	60.00	38.0	2.0
Class A Metal—Ferrule and setting pin	44,800	67,200	20	70.00	30.00
Class B Metal—Rings	26,880	44,800	30	65.00	35.00
Class C Metal—Rings (alternative)	13,440	26,880	10	60.00	38.00	2.0
Class G Metal—Per percussion pellets (alternative bodies)	17,920	44,800	20	65.00	35.00

Pellets and Other Details

The stirrup springs are stampings and hold the time and percussion pellets from arming on the time needle and ferrule respectively. The time pellet should arm at from 125 to 165 lbs., and the percussion from 77 to 99 lbs., while the ferrule arms at from 200 to 300 lbs.

The ferrule must be accurately made to give the correct weight, the analysis of the metal must be right, and the annealing accurately done for that analysis. The annealing, of course, varies as the analysis. If the zinc contents is high the metal will be harder and the temperature proportionately higher. This temperature varies from 890 deg. Fahr. to 1,200 deg. Fahr. and 15 to 20 minutes is allowed in the furnace, after which a water quenching bath is used.

Some manufacturers make these ferrules from brass tubing, some use bar stock, and some use sheet metal; cupping or drawing them out, chucking, cutting off the blind end, boring, putting on a mandrel and turning the outside. The last method is very slow and in this

country possesses no advantage over the other two, which permit of an output of approximately 6,000 per day on one automatic machine. The other two methods are simply matters of cost as to which is the cheaper. In all three me-

effect, the resistance of the spiral spring is overcome and the detonator is punctured, the flash extending through the pellet plug, which has a hole bored through it, and the base charge ignited, causing the shell to explode.

On the American fuses there are no ferrules or stirrup springs. The time pellet has a groove left where the pellet plug is screwed in, and into this groove is placed a split brass ring, which must slip over the edge of groove before the detonator can be pierced. The percussion element has a small pendulum, which is thrown out by centrifugal force due to shell rotating; as this pendulum swings out, a needle, which is formed on the other end, is lined up to strike a de-

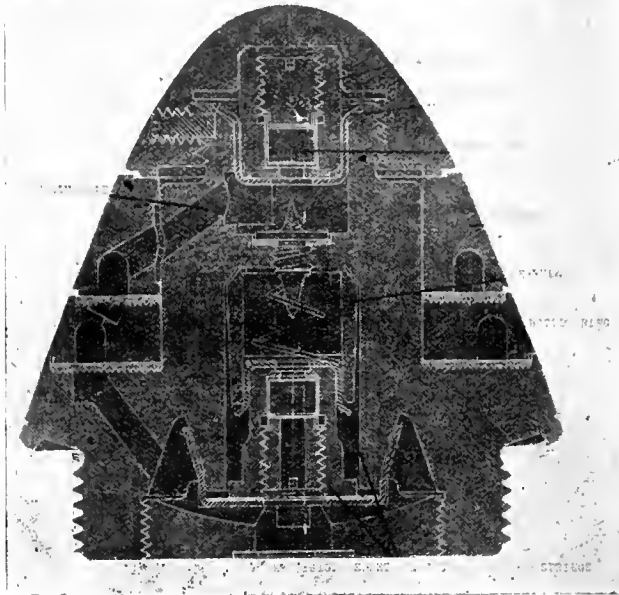

SECTION OF TYPICAL FUSE SHOWING PARTS REFERRED TO

thods of manufacture the product is afterwards sized with a broach, and the percussion pellet which is also part of

tonator when the resistance of two small spiral springs is overcome.

Arming Resistance of Pellets

The theory on which the arming resistance is figured is on the maximum allowable chamber pressure and the weight of ferrules.

Suppose:—
The area of gun equals 8 1/2 sq. inches; the chamber pressure equals about 15 tons.

Thrust of explosion in this area is against an 18-lb. shell.

If we find the amount of resistance of each grain of weight and multiply by weight of ferrule, we know what the set back of ferrule will be. The same argument holds good for the time pellet. Some specifications allow for a factor of safety to insure of the parts working, others do not.

The fuse bodies are cast in permanent moulds or chills, which give a closer, finer grained casting, free from gas holes and the increase in breaking strength is from 10 to 15 per cent., with 20 to 25 per cent. increase in elongation.

Sometimes the bodies are cast in green sand moulds and sized afterwards in a die, which gives a similar result to die casting, this alternative, however, being practiced with less success.



CANADIAN IRON AND STEEL PRODUCTION

THE Dominion Department of Mines has received from the producers a record of the production of pig iron and of steel ingots and castings during the first eleven months of the year 1916, which, together with the estimates for Decem-

ber, show a probable production of pig iron in Canada during the twelve months ending December 31, 1916, of 1,171,727 short tons (1,046,185 gross tons), and a probable production of steel ingots and direct castings of 1,454,124 short tons (1,298,325 gross tons), of which 1,423,485 short tons were steel ingots, and 30,639 short tons were direct castings.

The production of pig iron in 1915 was 913,775 short tons and of steel ingots and castings 1,020,896 short tons, showing an increase in the production of pig iron in 1916 of about 28 per cent., and an increase in production of steel ingots and castings of over 42 per cent. The 1916 production is greater than that of any previous year, the second largest production of pig iron having been 1,128,967 short tons in 1913, and of steel ingots and castings 1,168,993 short tons, also in 1913. The production in 1916 during the first six months and monthly during the last six months was as follows in gross tons:—

6 months ending	Pig Iron	Steel Ingots	Direct Castings	Total
June	501,577	577,999	11,715	589,714
July	82,154	101,178	2,284	103,462
Aug.	78,450	108,889	2,290	111,188
Sept.	91,736	116,828	2,524	119,352
Oct.	101,436	126,577	2,924	129,601
Nov., partly est.	95,237	119,468	2,745	122,213
Dec. est.	95,300	119,930	2,865	122,795

Six mons. end.				
Dec.	544,313	692,970	15,641	708,611
Twelve mons. end.				
Dec.	1,046,185	1,270,969	27,356	1,298,325

Of the total production of steel ingots and castings in 1916, about 43,790 short tons (39,098 gross tons) were made in electric furnaces. In 1915 only 61 short tons were reported as having been made in electric furnaces.



PRESSURE OIL FILM LUBRICATION*

By H. T. Newbiggin, A.M.I.C.E.

THE primitive form of journal bearing is merely a hole bored in the frame of a machine in which a shaft revolves, and the primitive thrust bearing is only a collar or shoulder on a shaft to prevent it moving endways. These fulfil their function satisfactorily for many purposes, but as the rubbing speed increases, either due to an increase in the shaft diameter or an increase in the speed of its rotation, or both, it becomes necessary to devote more attention to the design of these machine parts, apart altogether from the effect of a reduction in friction on the efficiency of the machine as a whole.

Without lubrication a bearing will not run without excessive wear, and without artificial cooling no bearing with oil lubrication will run continuously if the temperature rises above 150 deg. F., because at about this temperature most oils begin to carbonize. The efficiency of a bearing must, therefore, be such that the temperature due to the heat gen-

erated by its friction, minus that dissipated by radiation and conduction, does not exceed this figure. In order to reduce the friction between two rubbing surfaces it is necessary to put something between them, and bearings may be classified into those in which this is a hard material such as steel balls or rollers, or a viscous substance like oil or grease.

Ball and Roller Bearings

The first class does not consist merely in introducing balls or rollers between the relatively moving surfaces in the primitive forms of journal and thrust bearings, they are highly specialized machine parts designed to utilize to the greatest advantage the rolling action of balls or rollers in reducing friction, and their design is evolved from a study of this action. On the other hand (except in the cases to which reference will be made later), the second class consists merely in applying a lubricant to the primitive forms, or to some slight modification thereof. They are not designed to utilize the action of the lubricant on any principle, the lubricant is merely added to the primitive forms because it has been found to make them work better. Ball and roller bearings have attained to a remarkable degree of perfection, and they are admirably suited for bearings in which the loads to be carried are comparatively light, or in which the motion is intermittent, but they are not suited to carry heavy continuous loads, especially at high speeds.

In ball bearings the steel balls make point contact with hardened steel races, and the balls tend to flatten at the point of contact. Under excessive continuous loads this slight deformation of the balls causes their outer surface to shell off, the chips get under the other balls, and ultimately destroy the construction of the bearing. The life of the balls is limited, frequent renewals are necessary, and to effect these renewals it is essential to dismantle the bearing.

In roller bearings the rollers make (or are supposed to make) line contact with the housing and with the shaft. Although they are able to carry heavy loads, it is very difficult to maintain correct alignment, and any slewing of the rollers sets up a heavy end thrust against the cage in which they work. Furthermore, as the rollers bear directly on the shaft, the constant rolling action tends to laminate the surface and so wear it away. In roller thrust bearings it is necessary to make the rollers conical, and as they therefore have a heavy radial thrust this type of bearing is not much used.

The great advantage of both ball and roller bearings is their low starting friction; for this reason they are especially suitable for intermittently moving ma-

chinery, but in continuously running machinery, where a low starting friction is of less importance than a low running one, it is obviously a great advantage to have the rubbing surfaces separated by something more easily replaceable than either balls or rollers, especially if it is something that can be continuously replaced without stopping the machine, and the more so if it is also capable of being used in high-speed bearings as a medium for carrying away the heat generated by friction from the actual surface of its origin.

It is with the second class of bearings—those in which the surfaces are separated by a fluid such as oil in the case of high-speed and grease in the case of slow-speed bearings—that this paper is more immediately concerned. The use of a lubricant for the purpose of reducing friction is very old, but the study of its action, and more especially the manufacture of bearings designed to utilize this action to the best advantage, is quite modern.

Lubricant Action

The action of a lubricant is twofold: it first of all alters the nature of the rubbing surfaces, thereby reducing friction (and this is the commonly accepted justification for its use), but under favorable conditions it goes much further than this and automatically generates a high-pressure oil film between the surfaces, entirely eliminating metallic contact and thereby enormously reducing the friction. This is what is now called "pressure oil film lubrication." It occurs to a limited extent in most journal bearings, but does not occur in ordinary collar-thrust bearings.

The phenomenon of pressure oil film lubrication was first noticed by the late Beauchamp Tower during the course of a series of tests he made in conjunction with the Institute of Mechanical Engineers in 1883 and 1885. He found, while experimenting with a journal bearing, that under certain conditions the rotation of the shaft was capable of dragging the oil adhering to it in between the surfaces to such an extent as to force the surfaces apart with a high-pressure oil film, and that the highest pressure in this oil film was about twice the average pressure. He also found that the highest pressure was on the longitudinal centre line of the brass and a little forward of the sectional centre line in the direction of rotation, and that from this point the pressure fell to zero around the edges of the brass. A bearing under these conditions runs with very much less friction than under any other, and will carry a much higher load.

Following on Tower's experiments, the late Professor Osborne Reynolds, F.R.S., in a paper read before the Royal Society in 1886 on "The Theory of Lubrication," showed that the friction

*Part I. of a paper read recently before the British Association.

under the circumstances was merely that due to the viscous flow of the oil, and he showed how, by calculation based on the theory of viscous flow, a pressure curve

Thirdly—That such a wedge-shaped oil film cannot occur in a collar-thrust bearing; hence their inefficiency and low carrying capacity.

Fortunately a German publication (in 1905, on "The Lubrication of Plane Surfaces," he gave the complete mathematical solution of Reynolds's theory as

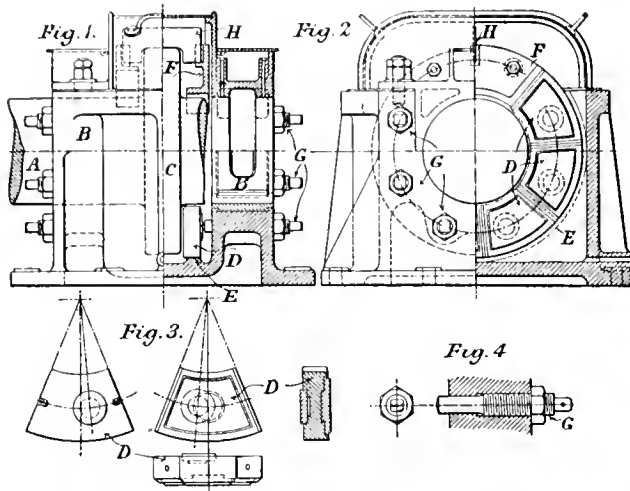

MICHELL THRUST BEARING DETAIL.

may be obtained which closely approximates to that obtained experimentally by Tower.

In his theory Reynolds made the assumption that the length of the bearing, i.e., the dimension at right angles to the direction of motion, was infinite, and as this is never the case in practice, his theory was of little practical value and it did not lead to any alteration in the construction of bearings. From the practical point of view the most important things that he showed were:—

Firstly—That in order to obtain a pressure oil film between lubricated surfaces the surfaces must have a slight inclination to each other, with the opening at which the oil enters greater than that at which it leaves. Or, in other words, that the oil film must be wedge-shaped.

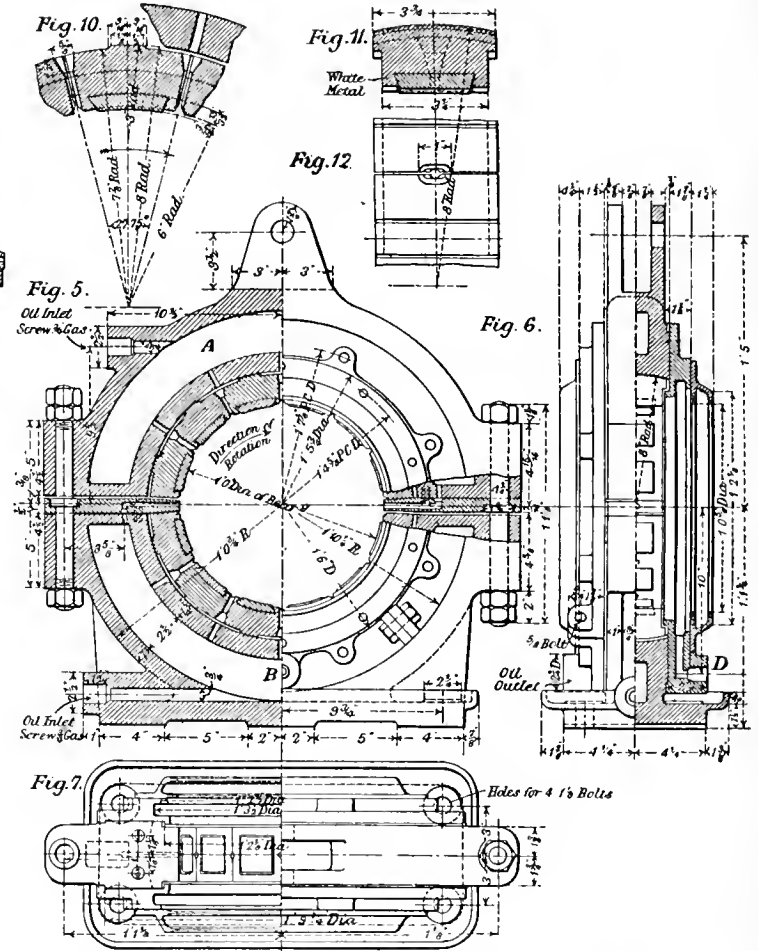

DETAIL OF MICHELL JOURNAL BEARING AS TESTED.

It was left to an Australian engineer and mathematician, A. G. M. Michell, of Melbourne, not only to complete Reynolds's theory, but also to show how its

applied to plane rectangular surfaces. On the assumption that the thickness of the oil film at the entering edge is twice as great as at the leaving edge, he

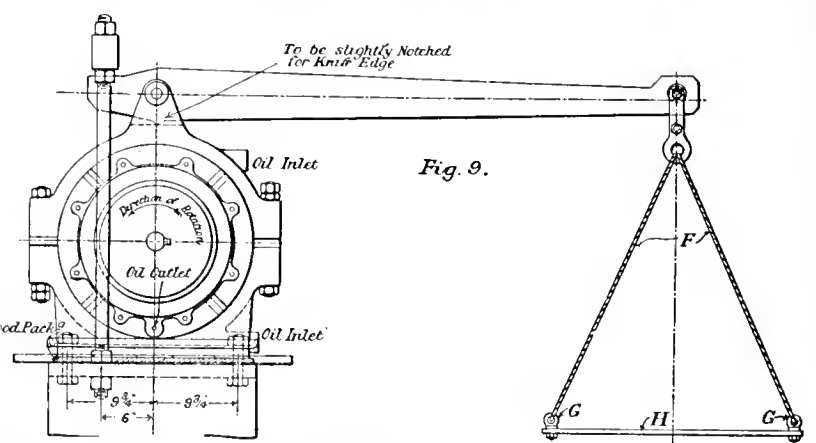
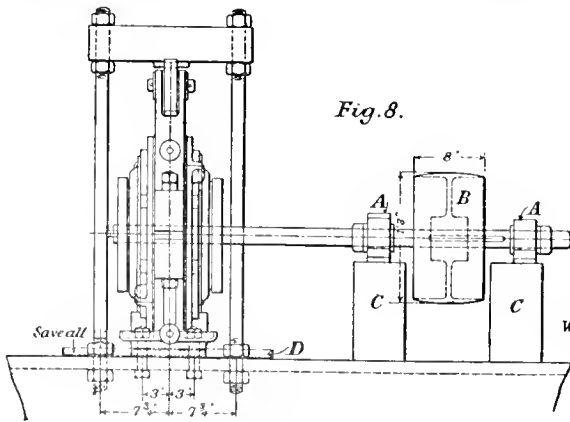

TESTING EQUIPMENT OF MICHELL JOURNAL BEARING.

Secondly—That in the case of a journal bearing the wedge form of the oil film occurs naturally, due to a slight shifting of the centre of the shaft in relation to the centre of the brass.

teaching can be applied in practice, to the vast improvement of both thrust and journal bearings.

In a paper published in "Zeitschrift für Mathematik und Physik" (unfor-

showed how lines of equal pressure within the film can be plotted and how the centre of resultant pressure can be determined for plane rectangular surfaces of varying proportional cross dimen-

sions. He also demonstrated practically that a rectangular block pivoted at its point of resultant pressure will automatically assume an angle to an opposing lubricated surface, depending on the speed of rubbing, viscosity of the oil and pressure. On this principle he founded his now well-known thrust bearing.

The result of Mr. Michell's work has been to enable lubricated thrust and journal bearings to be designed with the principles of oil film lubrication as a basis, in the same way as ball and roller bearings are designed with the ball or roller as a unit, and as distinguished from the mere application of oil to the primitive forms of these bearings. The essential feature of the Michell bearings is the sub-division of the stationary surface into a number of blocks or pads, each pivoted at its back, and so free to assume a slight angle with its contacting surface. Bearings designed on this principle differ radically from the primitive forms of journal and thrust bearings, but the results obtained in practice have fully justified the change.

Thrust Bearing Comparisons

Taking the ease of the thrust bearing first, the Michell thrust bearing differs from the older type in having only one collar, the multiplicity of collars in the older type having been necessitated by the low carrying capacity of parallel rubbing surfaces, as distinguished from the high carrying capacity of those in which the fixed surface is sub-divided and made free to assume the angle to the opposing collar necessary for the formation of oil pressure within the film.

The importance of efficiency in machinery is not merely a question of economy of power or fuel, it also controls the practicability of a design, and the design of bearings is an example of this. For example, in the design of a large multicollar thrust bearing (which is merely an elaboration of the primitive form) the problem the designer has to solve is governed by the efficiency of this form. He has given a shaft of a certain diameter, revolving at a certain speed, and which has to withstand a certain thrust. The resistance to turning will be about 0.03 of that thrust, and the greatest load that the bearing surfaces will carry with safety is about 50 lb. per square inch.

Low Coefficient of Friction Essential

In order to bring the pressure down to this figure, he may either use a few collars of large diameter or a number of collars of small diameter. If he does the former, he increases the radius at which the friction acts, and so the power absorbed and the heat generated, and if he does the latter it becomes increasingly difficult to maintain an equal distribution of the load among the collars, especially under the variations of expansion

due to the heat generated when the bearing is at work. Furthermore, whatever compromise he makes, there comes a point beyond which the size, load and speed cannot be increased because, owing to the high coefficient of friction, the heat is generated more quickly than it can be dissipated by radiation and conduction, even with the aid of water cooling.

This point was reached in the case of the thrust bearings in geared turbine-driven vessels, and partly because the bearings were found to be less able to withstand thrust under the uniform turning movement given by this type of engine than under the varying turning movement given by reciprocating engines. It therefore became necessary to find a form of thrust bearing in which the coefficient of friction is lower than that in the primitive type.

Michell Thrust Bearing Details

The Michell thrust bearing, which goes to the root of the matter and is designed from the point of view of the action of the lubricant in automatically generating a pressure oil film between the surfaces, has formed a complete solution of the difficulty. It has a coefficient of friction of about 0.0015 as against 0.03, and carries 200-300 lb. per square inch with a much greater factor of safety than the primitive form has at 50 lb.

The sub-division of the fixed surfaces into a number of segmental tipping blocks or pads is the essential feature of all thrust bearings made on this principle, but there are many variations in the design of the housing and method of carrying the tipping blocks, depending on the particular use to which the bearing is to be put.

Figs. 1 and 2 show sectional side and end views of one form in which marine thrust blocks are made. The shaft A is supported in two journal bearings B, one on each side of a single collar C, which bears against two series of segmental pivoted blocks D, arranged in the form of two inverted horse-shoes, the one for "ahead" and the other for "astern" thrust. The blocks D—each of which is pivoted, somewhat behind its centre, on the ends of the screws G—rest on two ledges E, concentric with the shaft. They are prevented from rotating with the shaft by means of the stops F, by removing which they may be taken out without disturbing the adjustment of the screws G or lifting the shaft. Figs. 3 and 4 show a detail of one of the blocks D, and of its screw G.

The body of the housing forms an oil well in which the collar revolves, and a scraper H is provided to scrape off the oil brought up by the rotating collar for the purpose of lubricating the upper blocks. This type is self-contained as regards lubrication, and in the case of

large sizes, or those running at a high speed, the body of the bearing is water-jacketed. The friction is about one-twenty-fifth of that in the multicollar type.

Steam Turbine Thrust Bearings

In the case of the thrust bearings in steam turbines the type adopted is somewhat different. The blocks are symmetrically disposed around the faces of the collar, and each series is mounted on a ring partly spherical on one face, the convex surfaces of which are outward and rest on correspondingly spherical seats for the purpose of automatically distributing the load among the blocks. The blocks are mounted on the faces of the rings next the two sides of the collar against which they pivot, either along radial lines or on rounded pins.

This type is entirely enclosed, and is supplied with an oil circulation by means of an independent pump. The oil passes through an oil cooler on its course, thereby removing the heat generated by friction from the actual surface of its origin. The mean rubbing speed sometimes exceeds 100 ft. per second. Slow speed bearings are made on the same principle, with grease lubrication.

Upwards of 800 Michell thrust bearings are now running in Great Britain alone, in sizes varying from 1 to 15 in. diameter of shaft, and larger sizes are in the course of construction. The use of them is rapidly becoming the standard practice in steam turbine work. The same principle is now being applied to journal bearings.

Journal Bearing Comparisons

In lubricated journal bearings of the primitive type (as already stated) the phenomenon of pressure oil film lubrication occurs naturally, due to the slight shifting of the centre of the shaft in relation to the centre of the brass, but its occurrence is much less marked in the case of bearings of large diameters, probably owing to the greater oil clearance that is necessary in large sizes and to the extreme thinness of the oil film. For example, a journal bearing of 2 or 3 in. in diameter will run satisfactorily under a pressure of 300 to 400 lb. pressure per square inch, but it is not found advisable to load large bearings above 100 lb. even with a forced oil circulation.

The pressure oil film only occurs along a narrow strip in the primitive type, and the remaining surface merely forms a brake on the rotation of the shaft. So that the designer is again restricted and can only reduce the pressure to the limit found safe in practice by increasing the length of the bearing. By sub-dividing the circumferential surface into a number of segments, each of which is pivoted at its back and thereby free to form an independent pressure oil film between

its rubbing surface and the shaft, the number of the pressure oil films can be increased, so that the full projected surface of the bearings becomes effective for carrying load, and the brake surface is eliminated. The friction is thus reduced, the load-carrying capacity increased, and the bearing shortened.

Michell Journal Bearing Tests

A series of tests has recently been run on a Michell journal bearing by Cammell, Laird & Co., Birkenhead. Figs. 5, 6 and 7 show details of the experimental bearing, and Figs. 8 and 9 the method of testing it. As will be seen from Fig. 5, the bearing surface is divided into 12 segments, each of which is pivoted on a rib at its back, so that it is free to lift at its leading edge to allow the necessary wedge-shaped oil film to form. These segments are shown in detail by Figs. 10 and 11. The faces of the segments or blocks are lined with white metal, each surface being 2 in. square, giving 48 sq. in. of rubbing surface, the equivalent projected area of each half of the bearings is 16½ sq. in.

In addition to the segments being free to tilt, the seat on which they rest is partly spherical, thereby making the bearing also a swivelling one. A circulation of oil was passed through the bearing, entering it between each pair of blocks from the chambers A and B, and escaping at D. The bearing was driven by means of an electric motor, and the ammeter and voltmeter readings recorded. Each run was continued until the temperatures of the oil were also recorded, together with the weight of the oil passing, and the revolutions per minute. The load was applied by adding weights to the scale pan H, shown in Fig. 9, the leverage being 11 to 1.

The annexed table gives the results observed, together with the friction calculated from the heat taken up by the oil. The friction is that for the two halves of the bearing pressed together. To get the coefficient of friction these figures require to be divided by twice the load.

TEST OF EXPERIMENTAL "MICHELL" JOURNAL BEARING. MAY, 1916.

Date and Duration of Test.		Total Load	Bearing Pressure	Revs. per Min.	Surface Speed	Amperes	Volts	Horse-Power Input	Final Inlet Temp. F.	Final Outlet Temp. F.	Rise of Temp. F.	Flow of Oil.	Friction Horse-Power from Heat to Oil	Coefficient of Friction	Actual Friction
May	Mins.	Lb.	Lb. per sq. in.		Ft. Min.				Deg.	Deg.	Deg.	Lb. Min.			Lb.
18	45	585	1,840	16.5	406	9.2	68	84	16	12.6	1.9
18	105	2,400	145	620	1,950	14.5	403	7.9	79	99	20	14.8	2.8	0.0069	47.5
18	105	3,600	220	615	1,930	16.0	395	8.6	84	101	17	14.3	3.3	0.0054	39.12
19	60	4,800	290	605	1,900	16.6	382	8.6	83	100	17	15.6	3.5	0.0045	43.7
19	40	6,000	370	615	1,930	16.9	395	9.1	84	102	18	17.6	3.0	0.0043	51.6
19	75	7,300	440	607	1,907	18.9	391	10.0	84	102	18	18.7	3.2	0.0038	55.4
19	45	8,500	520	605	1,900	19.0	393	10.2	83	99	16	19.0	2.9	0.0029	50.1
19	60	9,800	600	618	1,940	20.4	395	10.9	71	93	22	19.0	4.0	0.0024	67.6
20	90	11,700	700	611	1,920	21.0	391	11.1	76	100	24	19.7	4.5	0.0033	77.2
20	30	14,800	900	620	1,950	26.5	400	14.4	77	102	25	22.7	5.4	0.0031	91.7
24	30	7,315	4,130	23.0	390	12.2	76	95	19	23.0	4.1
24	60	2,400	145	1,320	4,140	27.8	392	14.8	74	96	22	26.4	5.5	0.0091	43.7
24	45	5,500	320	1,320	4,140	29.8	390	15.8	77	104	27	25.2	6.4	0.0046	51.1
24	60	8,500	520	1,303	4,100	40.0	398	21.6	82	117	35	33.0	10.9	0.0051	87.5
25	60	11,700	700	1,324	4,140	50.0	382	26.0	76	111	35	37.3	12.2	0.0042	98.3
25	105	11,700	700	1,317	4,140	42.0	390	21.2	73	112	39	31.2	11.5	0.0029	91.2
25	30	14,800	900	1,320	4,140	45.5	400	24.7	76	117	41	33.0	12.7	0.0034	100.4

Canadian Machine-Tool Industry on Sound Basis

For many years the engineering industry of this country was dependent on outside sources for the great proportion of its machine tools. The past two years have witnessed a wonderful development of tool building capacity, in specialized as well as staple lines and a resumption of ordinary manufacturing activity will find many firms capable of supplying suitable equipment.

THE impetus given to machine tool building in Canada by the demand for munitions equipment in the first eighteen months of the war has continued without abatement. Many of the improvised machines did excellent work but the constant cry for greater output along with the increased size of shells made, has resulted in the continued improvement of machine tool design, as well as the frequent appearance of new types of tools, accessories and processes.

A prominent example of specialized munition machine production is the Holden-Morgan Co., Toronto, who have developed their line of thread millers till it includes machines for 12 in. shells and over, two other sizes taking up to 6 in. dia. and 7 in. to 9.2 dia. respectively. Included in their product are a thread miller for base adapter plugs larger than 6 in.; a combined turning, facing and threading machine for gas check plugs up to 6 in.; a socket thread miller for outside threads on fuse sockets, nose pieces, etc.; a mechanical plug wrench for H. E. shells up to 6 in.; a nose slotting machine for milling simultaneously the three riveting notches on British 4.5 in. shells.

Cutting-off Machines

The cutting-off of billets and forgings has kept tool builders in this line very active, John H. Hall & Sons, Brantford, Ont., putting out a complete line up to their No. 12 machine which has a capacity of 13 in. through the chuck and drum. No. 6 machine which cuts from

4.5 in. to 6 in. is made up with double or triple tool blocks, permitting one, two or three cuts off stock at one chucking. The oxygen cutting torch has been successfully applied to the cutting of billet bars, the Carter Welding Co., having developed a machine of the multiple type equipped with four Davis-Bournonville cutting torches. In direct opposition to this is the Schoop Metal Spraying Process operated by the Metals Coating Co., Montreal, by which it is possible to deposit steel upon steel with a high degree of integral perfection.

Interest attaches to the output of the Canadian Boomer & Boschert Press Co., Montreal, their efforts in the hydraulic machinery line having resulted in their building forging presses up to 350 tons capacity; 5¼ in. x 14 in. vertical triplex power pumps, capacity 100 gals. per min. at 1,500 lbs. per sq. in.; 18 in. x 15 ft. accumulators, capacity 180 gals. per stroke, at 1,500 lbs. per sq. in., these items being the largest machines of their particular type at present built in this country. A special continuous operation press for gun cotton manufacture has also been developed by them.

Capacity production on standard designs of quick change type engine lathes has been the feature of the year's operations by the Canada Machinery Corporation, Galt, Ont., sizes from 14 in. to 26 in. inclusive having been largely installed in ammunition plants throughout the country. Their Hespeler plant has also done considerable business in

special machines for making munition boxes. The John Bertram & Sons Co., Dundas, Ont., have supplied a considerable proportion of the tools for larger shell production, many of these being standard designs, which, with slight additional equipment were well suited for sustained effort of a strenuous nature. Tread millers for the smaller size shells were produced to a large extent and the manufacture of special munitions fixtures for typhoid tools also received much attention.

The Tool Steel Feature

The manner in which machine tools have been pressed has only been possible by the existence of materials possessing the necessary cutting qualities, and it is a matter of peculiar interest that the two most efficient materials for this purpose are now being produced within the Dominion. Armstrong, Whitworth Ltd., are the pioneer manufacturers of high-speed steel, their works at Longueuil, Que., having produced this material for some time with very satisfactory results. A contrast is also offered in this direction by the proven success of Stellite, which is made at Deloro, Ont., and distributed by the Canadian B. K. Morton Co. Characterized as it is by a total absence of iron in its composition, this material possesses an extreme hardness at all temperatures up to red heat which enables it to cut at phenomenally high speeds without loss of temper, retaining its edge for long periods.

Canadian built milling machines are now on the market, the Ford-Smith Machine Co., Hamilton, having gotten out

a design of plain miller to meet the demand for this type of machine.

Shell Nosing Equipment

In munitions equipment a feature of the year has been the use of power and steam hammers for closing in the nose of medium size shells, the accuracy obtainable, through the use of the special equipment developed, enabling a later machining operation to be dispensed with. Greater uniformity in the quality of materials, improved forging and heat treatment have largely eliminated machining troubles so that grinding work is very much reduced, and in the larger shells is unnecessary. Specialization in munitions tools has been very marked, one outstanding instance being where all operations are performed on machines with hydraulic feeds, chucks and handling equipment with remarkable success. The milling of three slots in mark VII shells has resulted in special machines being placed on the market a simple type with three direct belt-driven cutters being marketed by H.W. Petrie, Ltd. For parties desiring to use existing machines a simple attachment has been built by Marsh & Henthorn, Belleville, Ont., which can be used on a milling machine, drill press or small lathe. It mills the slots in rotation and while not so rapid as the three cutter machines, its simplicity and adaptability render it a useful device.

Special band turning lathes have continued to be a feature of the output of Jenckes Machine Co., Sherbrooke, Que., being made in sizes up to 14 in., and tooled for foreign shells as well. General equipment has received consider-

able attention from several firms, Sheldons, Galt, Ont., having manufactured such lines as special tanks, resin boilers, bullet loading apparatus, electric painting machines and exhaust and ventilating fans, these being largely required for fumes from furnace rooms, lunch rooms, etc., in shell plants.

Ball-bearing transmission apparatus has received growing recognition as a standard item of factory equipment, the Chapman Double Ball Bearing Co., Toronto, having supplied the entire transmission material for the new Dominion Arsenal at Lindsay. Transfer trucks are also being more generally adopted, the Universal truck as built by this firm having been improved in several respects as a result of extended use in many lines of industry.



HIGH SCHOOL OF COMMERCE, TORONTO

By R. H. Eldon, B.A.*

PREVIOUS to the autumn of 1904, commercial classes were conducted in each of the city High Schools, then three in number. In September, 1904, the Board of Education transferred the commercial classes from the three city High Schools to the Toronto Technical School. The eight commercial classes in this school formed the Department of Commerce and Finance, and in September, 1911, this department was organized into the High School of Commerce, and located temporarily on Bathurst Street, and later, September, 1913, on Clinton Street.

*Principal, High School of Commerce, Toronto.

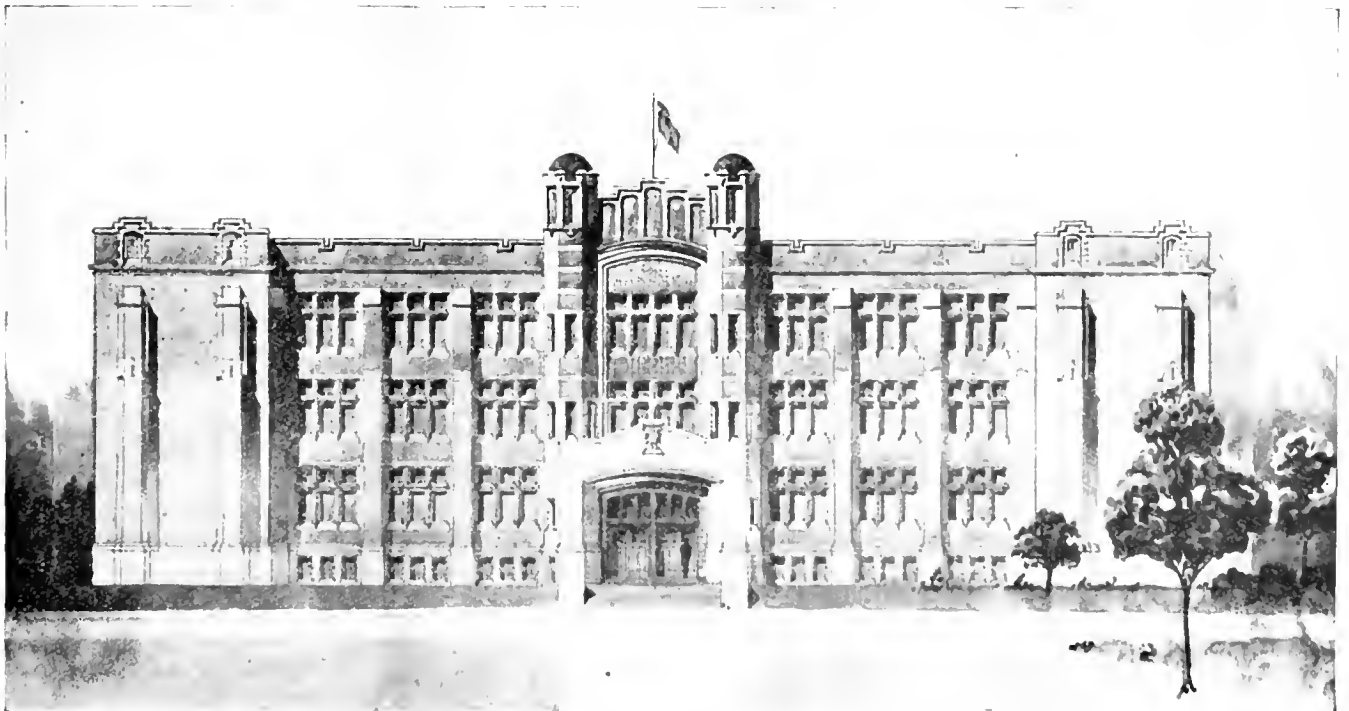

FRONT ELEVATION, NEW CENTRAL HIGH SCHOOL OF COMMERCE, TORONTO, ONT.

A suitable site and recreation grounds were purchased and a very fine up-to-date building has been erected thereon. The site is situated a little north of College; it extends from Roxton Road to Shaw Street, and is between three and four acres in extent. The new building was opened last September, and is being equipped with the most modern appliances for demonstrating business methods and systems of accounting, and for presenting the various aspects of business life.

Accommodation

The following accommodation is provided:—Twenty-one class rooms; one business practice room; one business practice office; two typewriting rooms; two study-of-material laboratories; two lecture rooms; one commercial art room; one commercial museum; two emergency rooms; one library and reading room; and an auditorium capable of seating one thousand persons. The basement, which is well above ground, contains assembling rooms, recreation rooms, bicycle rooms, and toilet rooms—on the west side for boys and on the east side for girls. There is also a students' supply room and a large cafeteria, located centrally between the boys' and girls' quarters, and thus readily accessible to both. When completed, the total cost of the building, equipment and site will be about half a million dollars.

Evening classes were opened in the Central School in October, 1912, while branch evening schools were opened as follows:—The eastern branch in Queen Alexandra School in 1912, the western branch in the Annette Street School in 1913, and the northern branch in North Toronto High School in 1914.

The school and its branches are under the management of an advisory commercial committee, appointed by the Board of Education. This committee consists of four persons selected from the Board of Education and four from the business men of the city.

Purpose of School

The purpose of the school is to give a general High School education, together with such a training in business theory and practice that students, besides being generally well informed, will be able to adapt themselves to the needs of any business with which they may become identified. Besides inculcating such requisites as punctuality, regularity, faithfulness, courtesy, and industry, and besides giving a knowledge of business routine, the purpose is to give such a training, such an outlook on life, as will develop prompt and accurate judgments—the cultivation of the intellectual equally with the mechanical, which is essential to leadership in the business world.

Particularly in the general business course are students given a knowledge of

the facts of nature and of the economies of the world around them. With this broader outlook they are inspired with an ambition which will enable them to advance more rapidly to superior positions in the business world, and to the more intelligently cope with the problems which will meet them in a business career. Thus, while the cultural side is not neglected, the aim is to make all the subjects serve the special vocational purpose for which this class of school exists, namely, a preparation for business.

Regular Courses

The following are the various courses offered to students. It is not intended, however, that these courses shall turn out thoroughly trained business men and women, but rather students so trained that they may readily adapt themselves to and master the details of any business with which they may become connected:

1—Accountancy Course.—This extends over three years, and is intended to fit students to become bookkeepers, accountants, etc.

2—Stenography Course.—This also extends over three years, and is intended to meet the needs of students looking forward to positions as stenographers, amanuenses, secretaries, etc.

3—Secretarial Course.—This is a broader course and extends over four years. It prepares students not only for stenography and general office work, but more particularly for the work of the private secretary.

4—Salesmanship Course.—This is also a broader course and extends over four years. Its purpose is to prepare students not only for general office work, but for positions that will eventually lead to salesmanship both in the warehouse and on the road.

5—General Business Course.—This course, like the two preceding, is a broader one, and extends over four years. Its purpose is not only to give a general High School education, but to assist those entering business with a view of succeeding to some of the more responsible positions, eventually becoming travellers, buyers, managers, partners, or proprietors.

The evening classes provide theoretical and practical instruction for both young men and young women—for clerks, salesmen, stenographers, bookkeepers, artisans, and others who desire to improve themselves in any of the following subjects:—Bookkeeping, business practice, business law, civics, penmanship, stenography, typewriting, spelling, business English, business arithmetic, rapid calculation, mensuration, algebra, study of material, salesmanship, French, German, or any other commercial subject for which there may be a sufficient demand.

The enrolment for the present season in the Central School is 550 for the day

classes, and over 1,500 in the evening classes. The enrolment in the branch evening classes is over 350, making a total of over 2,400.

TORONTO UNION STATION

SUFFICIENT progress has been made with the building of the new Union Station to enable a good idea to be formed of its ultimate extent and form and also its influence on the immediately adjacent district. The structure is being erected by the Toronto Terminals Railway Co., composed of three representatives each, of both the Canadian Pacific Railway and the Grand Trunk Railway.

The various officials responsible for the design and construction have devoted their entire energies and abilities to the object of the undertaking, viz., the provision of a perfect passenger terminal irrespective of cost. The area covered is rectangular in shape, the train tracks passing through the southern half, while the passenger accommodation and office building occupy the northern half. The travelling public is handled entirely in the central portion of the building, post office requirements being arranged in the extreme eastern section, and railway offices provided in the extreme western section.

Two main public entrances enable travelers to pass directly into the ticket lobby 250 ft. long, by 84 ft. wide, by 86 ft. high, which is in direct communication with the various conveniences of modern travel:—Parcels, baggage, lunch, telephone, telegraph, rest and smoke rooms. Extending southward from the lobby and situated below the train tracks is the train concourse, 100 ft. wide, by 230 ft. long, from which stairs lead up to the platforms above, these latter being 20 ft. wide.

Baggage is handled through special trucking subways which eliminate the necessity of trucking amongst passengers on the platform. Special provision has been made for handling light and heavy traffic, as under the latter conditions exit traffic is entirely separated from incoming. Very complete arrangements are to be provided in the way of immigration quarters, these being such that complete separation is effected from the ordinary passenger traffic, special accommodation such as kitchen, laundry, and offices being made. Hospital arrangements also are provided, these being in the west block.

St. Lawrence Closed.—With the arrival of the steamers Montcalm, Rouville and Lord Stratheona at Quebec on Dec. 25 navigation was officially closed on the St. Lawrence between there and the sea. This is one day later than last year.

EDITORIAL CORRESPONDENCE

Embracing the Further Discussion of Previously Published Articles, Inquiries for General Information, Observations and Suggestions—Your Co-operation is Invited

LINE SHAFT TROUBLE

By J. H. R.

AMONG the many problems that power users are required to solve, those arising from transmission are probably the most numerous. No one application is identical with another, and local conditions make it imperative that each installation, or the solution of trouble arising from unknown causes, must be dealt with on its own merits. Previous experience is often a guide to the difficulties of the moment, but unless a careful study is also made of the local surroundings, it is not to be expected that the results obtained will be entirely satisfactory.

Some time ago, a certain shop was confronted with considerable trouble on a portion of a line shaft, that taxed the patience of the foreman for quite a long period. The accompanying line drawing illustrates roughly the arrangement of the hangers and shafting. As shown, the center hanger came about midway between two joists, the next on either side being located on the other side of the joists. On numerous occasions, the center bearing would become heated and trouble would develop in the shaft coupling. This experience was not continuous, only taking place at irregular intervals. Several efforts were made to remedy the trouble by lining up the shafting, which on each occasion required, adjustment. However, the source was discovered one day when the foreman was on the floor above. He noticed a large pile of cased tin in the center of the floor and the vibration that developed when another case was added to the pile. Upon investigation, it was found that this lot of tin, weighing over two tons, was placed directly over the hanger which was giving trouble. Being an old building, this floor was not intended to support any

and hence originated the trouble. The removal of the cases to a more suitable position and the exercise of care in the subsequent location of all heavy loads effected an immediate and permanent cure.

JIG FOR DRILLING SEXTANTS

By R. Hamilton.

THE sketch herewith shows a very useful jig for drilling the holes in the outer rim of the sextant C. The jig A, which is secured to the drill table has a protruding arm, the outer end carrying the central pin D, upon which the centre

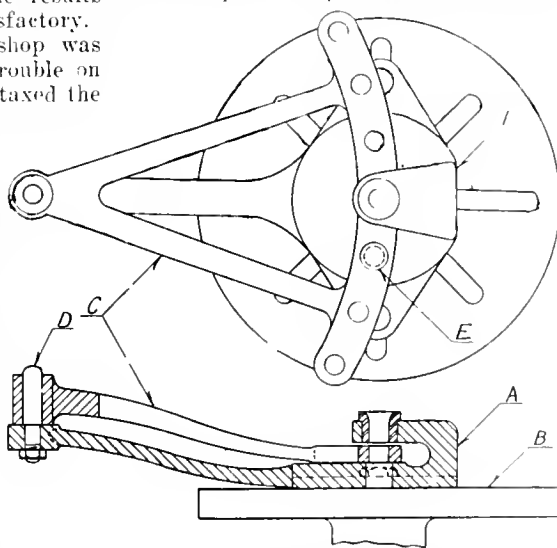

JIG FOR DRILLING SEXTANTS

hole of the casting is placed. After the first hole has been drilled, the position for the adjacent hole is determined by locating the pin E through the first hole and into the base of the jig. The spacing of the holes can be varied by the position of the pin hole in the jig base.

WHY THEY FAILED

By D. A. H.

TOM and Fred had been, respectively, salesman and designer for the R-Print-

ing so marked had given up their positions and started a shop of their own. In a year's time they had failed and sold out at a sacrifice to a rival who wanted to suppress the competition.

The cause of their failure was the same as that of many other men who leave big concerns and start a small one of their own. Not only were both good business men but they were alive and up to date, thoroughly familiar with the most efficient shop and office practice and knew the value of a dollar expended for men or materials. It had been decided at the beginning that quality should be first in everything, and at the end, no man could say that any work had ever been done that wasn't correct from a mechanical, or clerical or business standpoint. Overconfidence and lack of small shop perspective were the rocks on which they split.

An Ambitious Start

With \$50,000 capital Tom and Fred put a tenth of it in the plant (and a like amount on mortgage) which could have been leased for \$70 per month. Another \$2,000 went for alterations to make shipping and receiving goods at the cars an efficient process though the output was to be but two presses a month.

In common with most printing press work, many spur gears were required, also studs and shafts. Planing side frames and drilling them was one of the particular jobs. Good tools were bought, among them a turret lathe, a screw machine, a gear cutter, and a multiple drill, having in mind the operations just mentioned.

It will be seen that the work was carried on in the most approved way. But a man trained in the atmosphere of a scanty purse could hardly have thought in such an "approved" way. He would have bought stock gears, re-designing if necessary so he could have used them. Result—saved a few thousands for the future and got along without turret lathe and gear cutter to say nothing of patterns and small tools.

Overlooked Economies

Pattern cost was higher than need have been. Levers and arms and braces were designed in such a manner that while they showed real designing and made a finished looking product, they took a great deal of time to make the patterns with no decrease in the amount of machine work required and no corresponding increase in efficiency in the assembled machine over what the same parts would have shown if made a little heavier and plainer at a greater saving in pattern cost. Cores were used

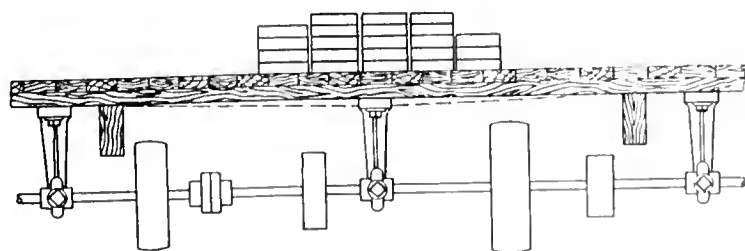

LINE SHAFT TROUBLE

great weight upon a small area. The result in this instance was a depression in the floor, which, being transmitted to the hanger, caused a bend in the shaft

ing Press Co. In their spare moments they had developed an automatic press of exceeding merit, had had several built on contract, and their success be-

where it would have been cheaper to have done machine work on the single pieces required. Patterns and castings were used when a blacksmith-made forging would have done.

Complete blueprints were made of everything down to the little "wrinkle" this fussy customer wanted, operation sheets were made out, time cards and stock cards were made as complete as the most ardent systematizer could have wished. But, the money spent for all the unnecessary equipment, the time spent (or rather lost) in carrying out the intricacies of an elaborate system, and the losses connected with being up-to-date and mechanically correct—all caused the failure of Tom and Fred. "Surely this was a blow for the advocates of efficient methods," said one. No, it only shows that we must discriminate and that what is meat for one is poison for another. If the money spent as mentioned had been conserved as working capital, the purchase of certain machinery delayed until it could have been made out of earnings, and for system, a hustling foreman or two with a good memory substituted the shop would have prospered, no doubt.

Hustle Best System

That "hustle" can be substituted for a great deal of system and unwisely spent money, can be proven by a consideration of an actual instance in a certain city where there were two shops each employing twenty men and each doing a line of manufacturing and "helping out" with job work and special machinery. In the first there was an office force of seven people besides a foreman who had nothing to do but direct the men and interpret blueprints. Even a repair job was the subject of cards innumerable, drawings, etc. by the office force and if it was a hurry job it could finally reach the shop in half an hour. That was the ideal shop "they knew how to do things," people said—and if a man went there with work he felt that he was being looked after; an engineer leaned back in his chair and duly considered point after point, draftsmen plotted them down, clerks made out cards—modern, scientific, efficient!

In the other shop there was "no system." The men put their time down on slips that the boss collected once a week; the boss did all the clerical work himself, though the business was fully as extensive as in the ideal shop. Then there was Sandy, the Scotch foreman, just the boss and Sandy and twenty men. If you took a breakdown job in there Sandy looked it over and planned the work as he looked and had one or more men at work on it in five minutes. If it was an engineering problem—a device or design or an estimate—Sandy pondered over it as he made his rounds and during a spare half hour sat down and sketched it out. In the end Sandy gave you just as good as the other people but got little credit for it—the uninitiated said, "there's no class

to that shop, no science"; but somehow the shop paid dividends and the ideal one did not and in the long run it got the trade—and grew to a size that could profitably adopt a system.

THE VALUE OF BRAINS

By A. L. Haas.

A WELL-KNOWN publicist, when speaking recently, remarked that the war had taught manufacturers a lot of valuable lessons. As one who had seen the thing from the inside, nothing had impressed him more than this—that the British employer and workman had not in the past placed the proper value they ought upon the service of brains.

In connection with the procedure of local tribunals, employers have appealed on behalf of men stated to be absolutely indispensable in business of considerable value, whose salaries were meagre and out of all proportion to their alleged value. Indeed, the most interesting question which has come to light in regard to compulsory military service has been just this one matter of responsibility and pay. Coupling the two things together, one is driven to conclude that admitted capacity and adequate reward therefor are more or less divorced, and that the conditions are not confined to any one country, but are universal.

Conditions Known

The facts are notorious and perfectly well known. It has hitherto been well-nigh impossible to find the door of opportunity open to simple mental power, uncoupled with other qualifications of a material order. Stupidity on the part of a workman is readily cited, but extraordinary intelligence when displayed goes unrecognized, the evident fear being that he might ask for advancement. Only those devoid of influence, who engineered themselves into superior positions, know exactly the struggle needed, the disappointments and delays inseparable from any material progress in their career. The competition among trained and capable men for posts at relatively low salaries proves the supply to be adequate. It is stuff and rubbish to point to lack of competition at the top of the scale. To state that the upper rungs of the ladder carry few men has no bearing on the point at issue; it merely points to the fact that very big jobs are relatively few.

The first question asked an applicant is what previous experience he has had in the precise post applied for! Where the candidate for honors is to commence to qualify seems never to trouble his interlocutor in this connection. Previous experience is admittedly valuable, but in too many instances points to a limited and routine experience—sometimes an unsatisfactory man given a good testimonial as a salve for virtual dismissal who, on the ground of former experience, gets the post. Previous experience is of less moment than capacity for extension, power of development and other factors few people can assess. Very few men adequately trained in a more general field with proper credentials fail to

develop under responsibility. Few are the firms, having sufficient faith in their own organization and belief in their own work as a ground for experience, who promote their own men. Reasons of discipline are cited if the question as to why an outsider was imported for responsible control is asked. Many a concern tied to a term agreement with a man in a responsible position bit their finger ends the major portion of the term after the new man's incapacity is revealed. Subsequently to end the impasse a first-class testimonial is handed out, and the incompetent is passed along elsewhere to repeat the performance. The feature of finding the right man already in employment is that a term agreement would not be needed, and from the employer's point of view no excessive salary need be paid. Hence both parties have greater freedom of action and each have less to lose.

Concerning the Mainspring

When judging between firm and firm, it is not easy sometimes to find who is the actual brain counting most in the economy of its organization. Sometimes it is one director, occasionally the chief draughtsman; or, again, some man rated no higher than a simple foreman may be the greatest force animating the whole. In spite of investigation sometimes no one can be held to be the man filling the important post of the power behind the throne. If a competitive business survives, it is obvious there is merit somewhere; it may rest entirely with the commercial side—more than one firm has been literally built upon the work of a single salesman. The remainder of the organization are often routine tied, devoid of initiative, or of any organization. For considerable success a combination of circumstances not very usual is needed. The mentality, width of vision and training are taken for granted, but unless the possessor also finds opportunity to develop or scope for energy in a direction which suits his temperament and fits his peculiar abilities he can never realize himself or rise to the height of his powers.

Every case whereby ability is penalized is a national loss. More might be done to discover talent.

Success Defeats Success

Sometimes when a man is extremely successful in one direction, the treatment meted out is similar too often to that of a workman becoming unduly expert on a single job. He is kept repeating his prowess in a circle of small magnitude. A man, successful in a limited field, deserves a better fate; if acute, he speedily realizes that the surest way to constrict opportunity is to be too expert. Actually, his reward should be fuller opportunity, bigger responsibility, and the chance of greater scope. The man finds it necessary to go elsewhere almost unwillingly, to the detriment of his original firm, who lose services they can ill-afford to lose could they only hold him. In too many instances a word of encouragement and promise to consider his claim to advancement when opportunity occurs would keep him satisfied.

We are told to place proper value on the service of brains; they are a reasonably cheap commodity, in view of facts now coming to light. The mentality normally expected in the engineering trades would stagger some outside professional men could they be made to realize the requirements expected for the salary paid. The responsibility which rests upon the man in control of 1,000 men is less in amount, but not in intensity, than that of a military chief or ruler of a country. His mistakes may perchance be less appalling, but his perplexities are certainly not less than those of more public, and consequently more realized careers.

Various methods may be tried. One usual in the shop is to take the nearest circular pitch in inches, and calculate the usual ratio of Drivers to Driven to this point of accuracy. For instance, 1.05-in. may be used for 3 D.P. (1.0472-in.). This method gives fair results when the error in lead is negligible, but, in most cases, the difference between the worm lead cut and the real lead is considerable, and results in large frictional losses, and low efficiency in the finished product.

A second method sometimes used is to substitute for circular pitch the constant "pi" divided by the diametral pitch, and calculate the requisite change wheels, assuming the value of "pi" as 22/7. This value is, however, only approximate after all, and with large leads may result in serious errors, again producing low efficiency, due to frictional losses. A more accurate method is, therefore, needed.

That here suggested assumes a similar calculation, but depends for its accuracy upon a more careful selection of the value of "pi". This value has been known for a few hundred years in the mathematical world, but seems to be neglected by engineers. The value is simple to remember, viz., 355/113 = 3.1415929, and is accurate to one in 10,000,000, and can, therefore, be taken as practically exact.

The standard rule for screw-cutting is:

$$\frac{\text{Drivers}}{\text{Driven}} = \frac{\text{Lead to be cut}}{\text{Lead of lead screw}}$$

The lead of the worm to be cut is however:—

$$L = \frac{\text{"pi"}}{\text{D.P.}} \times \text{No. of threads.}$$

$$= \frac{113}{5 \times 71} \times \frac{N}{\text{D.P.}}$$

therefore

$$\frac{\text{Drivers}}{\text{Driven}} = \frac{113}{5 \times \text{No. of starts}} \times \frac{N}{\text{D.P.}}$$

Driven 113 D.P. × Lead of lead screw
Hence for the small outlay necessary in providing the master gears of 71 and 113—the cutting of which can be done in the shop, we can cut any given diametral pitch worm, and pitch and number of starts, provided the lathe proportions are sufficient to stand the strain. Take, for example, a 5 D.P. worm, 3 threads 1/2-in. lead screw:—

$$\frac{\text{Drivers}}{\text{Driven}} = \frac{71}{113} \times \frac{5}{5} \times \frac{3}{1\frac{1}{2}}$$

$$= \frac{71}{113} \times \frac{120}{20}$$

The resulting gears show that the strain on the lathe will be heavy, but with care it can be done, and the saving will be considerable.

For the ordinary shop, high carbon steel—say .40 or .50 per cent. carbon, will be sufficient, if highly polished on the threads; but if mild steel, case-hardened and finally ground on the threads, be used, care must be taken to have the same ratios on the grinder as on the lathe, or the advantages of the accurate cutting will be lost.

CUTTING DIAMETRAL PITCH WORMS

Herbert's Monthly.

IT may well happen that a firm doing the necessary gear cutting for its own specialties requires to make a worm reduction gear for some accurate job, but wishes to reduce expense and time by doing the cutting in the shop, hobbing the wheel, and cutting the worm thread in the lathe. This operation will necessitate a worm of exactly similar dimensions to the hob, and will be a comparatively easy proposition if the hob be of circular pitch proportions. As, however, the modern method of gear selection utilizes the advantages of the diametral pitch system, the majority of the hobs used will be of this type; and much confusion will ensue if a diametral pitch worm is sent to the turnery to be cut.

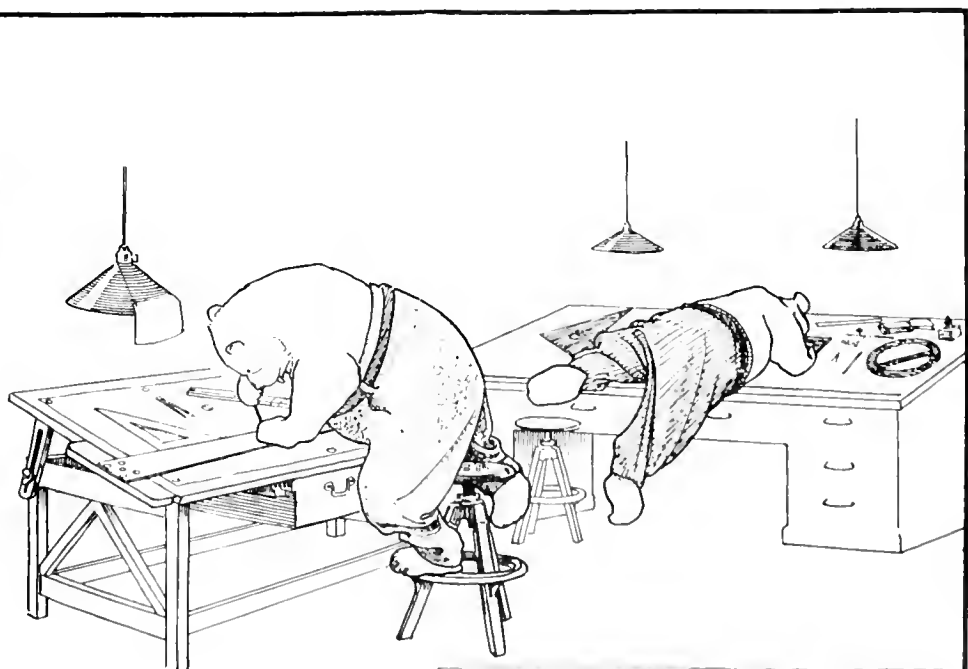

No. 2 The Drawing Office

We make Castings.
either to
Your Own Design,
or
we will design them
to fit
Your Requirements

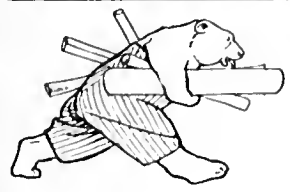

As this value of "pi" is far beyond the limits of commercial accuracy, almost perfect engagement should ensue, and a maximum efficiency obtained for the spiral angle taken.

Appendix

This value of "pi" may be obtained by the use of the continued fractions method, assuming "pi" = 3.1416.

$$\begin{aligned}
 \text{"pi"} &= 3 + \frac{1}{1416} \\
 &= 3 + \frac{1}{\frac{10000}{9912}} \\
 &= 3 + \frac{1}{\frac{88}{1416} + \frac{16}{1408}} \\
 &= 3 + \frac{1}{\frac{88}{88} + \frac{1}{\frac{1}{7} + \frac{1}{16 + \frac{1}{11}}}}
 \end{aligned}$$

Or, evaluating:—

$$\text{"pi"} = 3 + \frac{1}{7} + \frac{16}{113} \text{ or } 3.1416.$$

The first value 3 1/7 is the usual one adopted. The second 3 16/113 is the one employed above. The third is the value we commenced with.—
Herbert's Monthly.

BUILDING TRADES ACTIVITY THROUGHOUT THE DOMINION

THE building trades through their varying activity form a generally accepted barometer of trade conditions throughout the country. Much of the present year's activities are directly due to war-stimulated trade, but it is of interest to note that much of the Western business in the past year, and projects for next year are based on generally prosperous conditions and are not dependent on specialized industrial activity of a possibly temporary nature.

Galt, Ont.

This has been a record year for building operations in Galt, the total expenditure on new buildings being expected to reach a quarter of a million dollars, or at least \$100,000 ahead of last year. Up to November 30 the permits totalled the satisfactory figure of \$227,795, compared with \$140,249 for last year.

Kingston, Ont.

A decrease of \$22,009 is reported in the value of building permits issued up to end of November, 1916, the total value being \$181,451. Much will depend on the war as to whether the situation assumes a more favorable outlook for next year.

Lethbridge, Alta.

Fifty-four building permits of a value of \$97,290, were issued to the end of Nov., 1916, the year's building being very light

due largely to scarcity of labor; should this feature improve, an increase of building is expected next year in view of satisfactory harvest conditions.

London, Ont.

Up to Dec. 11 the total number of permits issued for 1916 numbered 1,017, with a value of \$912,385.

Montreal, Que.

A decrease of 175 in the number, and \$435,807 in the value of building permits for eleven months ending Nov. 30 is reported, the 1916 figures being 1,800 permits of a value of \$5,005,464.

New Westminster, B.C.

New buildings to the value of \$53,000 and repairs to the value of \$33,000 make up the total of \$86,000 value of building operations during the year. Despite the present dullness improved conditions are looked for in the spring.

Regina, Sask.

Building permits numbering 108, of a value of \$219,875 represent the ordinary business to Nov. 30, this being exclusive of the Imperial Oil Co. plant, which has cost \$1,500,000 to date, with further increases likely during the coming year. General prospects for 1917 are very good.

St. Catharines, Ont.

An increase of 43 per cent. over 1915 is shown in the value of building permits issued, having a value of \$637,570. Permanent factory buildings and workmen's homes form a large proportion of the year's operations, the demand for dwellings of this class being expected to increase still further next year.

Saskatoon, Sask.

A large increase in building activity is shown in the value of permits issued during the past year, numbering 108 and valued at \$144,550, about 70 per cent. of this being new buildings. Many projects held up during recent years are expected to materialize next year as a result of improved general conditions throughout the West.

Sherbrooke, Que.

Building permits for the past year amount to \$367,950, the building trades having been very busy. Much work is planned for next year and the outlook is considered good.

Stratford, Ont.

A slight decrease from last year, shown in the value of this year's building permits, \$186,504, is accounted for by the presence of several big contracts last year, the general business being about equal. The coming year is expected to be more active than the past.

Toronto, Ont.

Building permits numbering 3,690, of a value of \$6,452,823 were issued up to Nov. 30, an increase of \$497,797 in value and a decrease of 495 in number. The total amount of the year is expected to approach the ten million mark, which

would exceed last year by 50 per cent. Business for next year is expected to continue good.

Vancouver, B.C.

Building permits issued for first 11 months of 1916 totalled 384, of a value of \$2,126,524. The estimated total value for the year is \$2,375,000, showing a substantial increase over 1915. The outlook for 1917 is very favorable.

Welland, Ont.

Although 184 building permits were issued up to Nov. 30, of a value of \$191,362 and showing an increase of 11½ per cent. over 1915, the value is still 65 per cent. below that of 1913. A steadily increasing demand for small houses exists, this and factory additions being promising features of the coming year.

Westmount, Que.

The total number of building permits issued during the year was 114 valued at \$546,660, 78 of these being for new buildings principally private residences and garages valued at \$512,815.

Windsor, Ont.

Building permits numbering 550 were issued for eleven months ending Nov. 30, totalling \$1,420,930 in value, an increase of \$826,660 over the same period of last year. Prospects for 1917 are considered good.

CANADIAN POWER PRODUCTION

THE generation of electricity in Canada, and its division as between domestic and export business, is dealt with in the report of the Inland Revenue Department, issued December 22. It is of especial interest because of the discussion as to exportation of electrical energy.

The Canadian Niagara Co., figuring on the basis of kilowatt hours, produced 400,521,090 units for export, and 11,178,910 for use in Canada. The Electric Development Co. exported 34,652,000, and produced for use in Canada 395,346,500 units. Other companies divided their production as follows:

	Export	Domestic
Ontario Power Co.	199,135,160	616,834,440
Ontario and Minn.	13,144,070	11,789,534
Cedar Rapids Co.	358,753,000	56,031,000
Sherbrooke Power Co.	230,820	8,605,200
Maine & N.B. Co.	3,077,893	242,437
Western Canada Co.	11,937,700	60,468,020
B. C. Electric	330,626,680	470,689

Bonus to Employees.—The directors of the Canada Steamship Lines have set aside a sum of \$50,000 for the purpose of adding an acceptable bonus to the Christmas salary of all its permanent employees throughout the country. This is the first time such a generous Christmas fund has been provided for the employees of the company, and, in fact, the first time that such a fund has been provided at all. That it should come now is indicative of the cordial relations which have grown up among all sections of the company's services in late years.

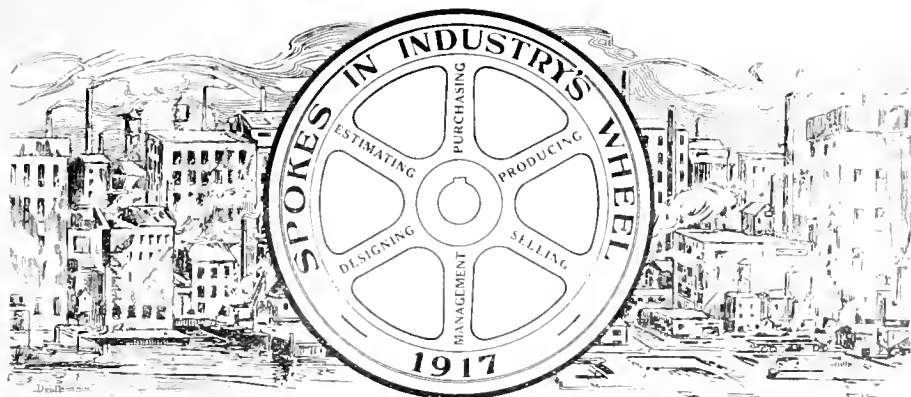

The constitution of industrial enterprise is largely departmental—"spokes in a wheel." This series of articles has for its object the featuring in a racy, interesting and instructive fashion, the training, experience and achievement of those who to-day are transmitting, effectively, energy in their capacity as "spokes in the wheels" of our metal-working establishments.

THOMAS BAIRD REID

IN CANADIAN machine tool circles, and particularly in the triple connection of maker, dealer and user, it may be said that there lives, moves, and has its being, no more widely known a personality than Thomas Baird Reid, Manager of the Machine Tool Department, A. R. Williams Machinery Co., Toronto, Montreal, etc. Machine tool manufacture in a specialised sense has not yet achieved in Canada the degree of prominence so evident in the United States, hence the necessity in many instances, even in normal times, to resort to the latter to meet both our metal and wood working plant requirements. Needless to say, Mr. Reid has figured largely in business transactions arising therefrom, with the result that he is to all intents and purposes as well-known across the border as he is here, and his sterling qualities are no less highly appreciated.

Tom Reid, as he is best known in the machinery business, was born at St. George, Brant County, Province of Ontario, on October 3, 1882, of parents who had come from the "hame and haunts o' Rabbin Burns," a circumstance that doubtless accounts for his inbred, and "automatic" winsomeness in the pursuit of his calling. He was educated in St. George public school and in Brantford High School, matriculating from the latter at the age of seventeen.

Following an apprenticeship with the Waterous Engine Works Co., Brantford, Ont., he went to the United States in 1901, spending some four years there at work in machine tool and locomotive building shops in several American cities where these products are turned out high in grade and large in quantity. Returning to Canada in 1905, he joined the sales staff of the Canadian Fairbanks-Morse Co., leaving them however, about a year later to become machinery salesman with the A. R. Williams Co. With the passing of 1916, a service of over ten years in the latter employ falls to be recorded for Tom, the last seven

being in the capacity of manager of the Machine Tool Department.

As might be expected from his Ayrshire extraction, Mr. Reid is Presbyterian in Religion and Liberal in Politics. He is, however, thoroughly Canadian in sport, having been in his younger days at Brantford a member of the Dufferin Rifles, inside home player on the lacrosse team, centre half-back on the Y.M.C.A. Senior Football Team, and the hero of many basket-ball encounters as well. He is an enthusiastic motorist and howler, the



THOMAS BAIRD REID

latter as a member of the Parkdale Lawn Bowling Club, Toronto.

Mrs. Reid was Miss. Edna Sawtell, youngest daughter of John B. Sawtell, Toronto, the wedding taking place in 1907. The family residence is 70 Beatty Avenue, Toronto.

Since the outbreak of the war and the inauguration of munitions manufacture in Canada, Mr. Reid has investigated and directed the purchase, as

well as conducted the sales of machinery running into several millions of dollars in value; in addition, he has personally engineered and equipped something over fifty complete metal-working plants in Canada and three of large production capacity in the United States. Included in the foregoing are to be found such plants as those of the Ford Motor Co., Ford, Ont.; Transcona Shell Co., Winnipeg, Man.; Canadian Tube and Iron Co., Montreal, Que.; Metal Drawing Co., St. Catharines, Ont.; Wilford Engineering Co., Lindsay, Ont.; Holden-Morgan Co., Toronto, Ont.; Framingham Machine Co., Framingham, Mass.; Woonsocket Machine & Press Co., Woonsocket, R. I., etc.

A specially noteworthy factor in Mr. Reid's work during the past two years and one that has been of the greatest material aid to him in the investigation, purchase and sale of munitions equipment on behalf of his firm and its clients respectively, was that of the practical shop training he received during his apprenticeship with the Waterous Engine Works Co., at Brantford, and later in the States. This will perhaps be better and more fully appreciated when we state that, from his ideas and developed designs, quite an imposing number of special machines and special tools for munitions and other services have been manufactured for and sold exclusively by his firm, the A. R. Williams Co.

Tom Reid, like a host of other men prominent in the machine tool and allied fields attributes much of his success to having been a close and constant reader of trade and technical publications, recognising these as indispensable channels of up-to-date information covering machine design and operation, readily available and at low cost with which to supplement both home and technical school studies. Having proved their value, he is therefore, qualified to express a decided and worth-while opinion. "Mechanics, young and old," he says, should subscribe to, read and study, trade and technical journals bearing both directly and indirectly on their work, as only by so doing can they be kept fully posted in the latest developments in new equipment, and the evolution of production methods and devices relative to greater quantity and higher quality output."

From time to time statements appear in the press to the effect that when the history of the war, comes to be written, or the story printed of what some one man or some body of men have done or are doing in some department of its many-sided activities, we will be mightily surprised with the accomplishment record. No one is prepared to doubt such predictions, generally speaking, however, in the case of Tom Reid's work on behalf of shell making in Canada, there is no need to wait for the historian at a post-war date, neither is there lacking right now the accomplishment record, for our machine shops over the whole wide Dominion express

it in shell and shell part output, irrespective of size and type. Although having much reason to be justly proud of his munitions machinery installation achievement, it may be said without fear of contradiction that Tom still takes the same size hat, and in saying so, we say much.

Canadian Machinery takes this opportunity of wishing him a Bright and Prosperous New Year alike in his home and in his business.



INDUSTRIAL DEVELOPMENT OF HAMILTON, ONT., DURING 1916

FROM the accompanying data, it will be noted that Hamilton, Ont., has, during the past year, quite maintained its reputation both for attracting new factories within its borders and making it worth while for those already established branching out to wider scope activities. Six new factories were located during 1916 as follows:—Perkins Glue Co., Lansdale, Pa.; Stanley Steel Co., New Britain, Conn.; Watkins Medical Co., Winona, Minn.; Turner, Day & Woolworth, Louisville, Ky.; Ontario Yarn Co.; Hamilton Steel Wheel Co. Seventy-one new factories and additions were erected during 1916, of a total value of \$994,446. Those of \$5,000 or over follow:—

FACTORY.	PROJECT	COST	MANUFACTURE
Steel Company of Canada	Additions	\$259,096	Munitions
Zimmerman Mfg. Co.	"	26,000	Knit goods, underwear
Mercury Mills Co.	New factory	125,000	Hosiery
T. Eaton Co.	Additions	11,000	Knit underwear
Canadian Cartridge Co.	"	73,000	Munitions
Tallman Brass Co.	"	16,200	Brass goods
Dominion Steel Foundries	"	70,000	Munitions
Dom. Power & Transmission Co.	New steam plant	200,000	Auxiliary steam plant
Standard Underground Cable Co.	Addition	25,000	Cables, telephone, telegraph wires
Chipman, Holton Co.	New factory	15,000	Hosiery
Brown, Boggs Co.	Rebuilding	11,000	Had a fire
Hamilton Steel Wheel	1st unit	8,000	Steel car wheels
Stanley Steel Co.	New factory	14,000	Cold rolled sheet steel
Grasselli Chemical Co.	Addition	48,000	Chemicals
National Steel Car	"	9,000	Munitions
Apoleford Counter Check Book Co.	"	7,500	Counter check books
Dominion Sheet Metal Co.	"	6,000	Galvanized sheets
Hamilton Bridge Works	"	7,500	Structural steel
Can. Steel & Wire Co.	"	5,500	Wire fence
Frost Wire Fence Co.	"	5,000	Wire fence
Union Drawn Steel Co.	"	5,000	Drawn steel shafting
United Gas & Fuel Co.	"	5,000	Water gas plant
Cumner-Dowswell Co.	"	10,000	Washing machines
Canadian Cotton Co.	"	6,000	Textiles
Proctor & Gamble Co.	"	5,000	Soap
Victor Saw Works	"	6,000	Hack saws
Bell Thread Co.	"	5,000	Cotton thread
Can. Shovel and Tool Co.	"	6,000	Shovels
Burlington Steel Co.	"	5,000	Steel shapes and angles
Can. Hart Wheels Co.	"	7,000	Grinding wheels

MAGNETIC INDICATOR FOR CRITICAL TEMPERATURES

THE fact that steel loses its magnetic properties on attaining the critical temperature forms the basis on which has been designed the "Crit-Point," an instrument which infallibly indicates the instant when a body of steel has attained the decalescent or hardening point.

In heat treating installations of the usual type, entire reliance is frequently placed on the permanent accuracy of the pyrometer, which is subject to variation

through deterioration of the thermo-elements; the element of time demands consideration so that the steel may assume a uniform condition at the required temperature; the personal factor appears in determining whether the two foregoing conditions have yielded the result desired.

Trouble due to misapplication in any

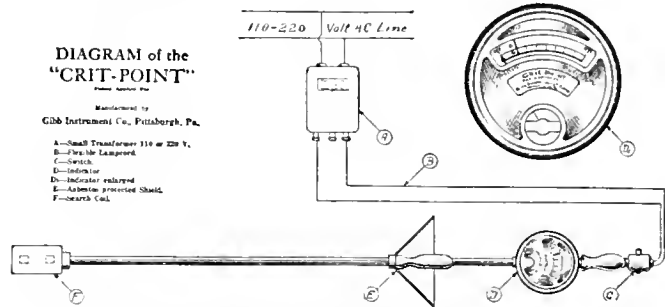

MAGNETIC INDICATOR FOR CRITICAL TEMPERATURES OF STEEL DURING HEAT TREATMENT.

of these respects is entirely eliminated by the instrument referred to, which indicates the critical point, not as a degree of temperature, but as a non-magnetic state. The instrument consists of a contact box containing magnet and coils, mounted on one end of a rod provided with handles and heat shield. The

ONTARIO BOILER RULES REVISION

A PROPOSAL is under consideration to revise the Rules and Regulations covering the construction and inspection of steam boilers in the Province of Ontario. A meeting was called by Dr. Riddell, superintendent of the Trades and Labour Branch of the Department of Public Works at the Parliament

Buildings, Toronto on Dec. 28, for the purpose of ascertaining the views of those interested. It is proposed to prepare a Bill for presentation before the Provincial House, which will be a revision of the Act already in force. The delegation consisted of representatives of steel and cast iron boiler manufacturers, boiler inspectors, stationary engineers.

Dr. Riddell in calling the meeting to order asked for a frank discussion of the proposed rules and said he would be glad to receive any suggestions that might be helpful in the preparation of a Bill that would meet with the approval of all the interests concerned. The proposed rules which were read by D. M. Medcalf, chief boiler inspector were discussed in detail and suggestions taken down in the minutes.

At the conclusion of the meeting it was decided to send copies of the minutes to all boiler manufacturers, inspection companies, etc., who will in turn submit their views to Dr. Riddell. It was further decided to appoint a committee composed of two representatives from each of the following interests:—Steel boiler manufacturers, cast iron boiler manufacturers, boiler inspection companies, stationary engineers, boiler users, and manufacturers of fittings. The committee will confer with Dr. Riddell and will be authorized to make any suggestions which will tend to improve the present Act.



AN alloy has been produced which is claimed to be an entirely satisfactory substitute for platinum, either as crucibles or as ignition tubes, thermo couples, etc. The new metal is called rhotanium, and is reported to be an alloy of metals of the platinum group. The price of the new alloy is the same as that of platinum, but its specific gravity is about half that of platinum.

other end of the rod carries a magnetic flux meter, the needle of which indicates the gradual approach of the steel to the non-magnetic, or critical point. Immediately contact is made with the steel in the furnace through the medium of the magnetic coils, the needle indicates the degree of magnetism in the metal, all knowledge of the actual temperature being irrelevant, so far as the indication of the critical temperature is concerned.

The makers of this instrument are the Gibb Instrument Co., Pittsburgh, Pa.

PROGRESS IN NEW EQUIPMENT

A Record of New and Improved Machinery and Accessories for the Machine, Pattern, Boiler and Blacksmith Shops, Planing Mill, Foundry and Power Plant

FUSE-GRADUATING MACHINE

THE fuse-graduating machine shown in the illustration has been developed for the purpose of graduating fuse rings and bodies, a work which calls for extreme accuracy. The fuse body is held in an air-operated draw-in collet chuck, carried in a chuck shaft or spindle supported in two bearings. The graduating die is carried on the inner end of the belt driven shaft which is located at a suitable angle, and is geared to the work spindle through a train of bevel gears arranged to give a relative reverse motion between the two members.

Ordinary punch-press trip gear is fitted to the belt pulley, which allows the parts to make one revolution only for each pressure on the foot lever. The graduating dies generally have a blank space which is arranged to be next the work when stopped; as the work can thus be placed in position or removed without setting back the dies, this allows the dies to be set to their full depth. Marking is done ordinarily in one revolution, although if the material be unusually hard, two or three revolutions may be required.

The gears used are approximately four times the diameter of the work, and all backlash is removed by suitable adjustments to insure complete accuracy.

Pressure of the die on the work is obtained by suitable weights operating through a bell crank, additional weights being added as the die becomes dull. In certain types of fuses the pressure is

great enough to disengage the work from the chuck and the necessary support is obtained through toggle arrangement shown which maintains a supporting arbor against the work during the marking. The illustration shows the general appearance of the machine which is built by the American Ammunition Co., Bordentown, N.J.



FORMED CUTTER RELIEVING MACHINE

THE accompanying illustration shows a backing-off machine for relieving formed cutters which is built by the Becker Milling Machine Co., Boston, Mass. It is designed to give straight or peripheral, side and end relief for all work within its capacity.

It is of the arm type of construction, special ways being provided for maintaining alignment of the tailstock which is secured in place on the arbor by four clamping bolts, the maximum adjustment of the tailstock being 24 in. The spindle is machined from crucible steel and has a maximum diameter of 3 $\frac{3}{4}$ in. It runs in solid phosphor-bronze bearings having compensation for wear, and is driven through a spur gear mounted directly on the end. A No. 13 B. & S. taper hole is provided in the spindle, accommodating a 3 $\frac{1}{4}$ in. draw bolt, clutch drive from the spindle nose insuring positive rotation of the tool to be relieved.

The cam shaft operates a single throw cam at the back of the machine, giving relief from zero to $\frac{1}{4}$ in., the wear on

cam rolls being taken up by tapered gib to insure positive throw. The cutter to be formed or relieved, can be placed in proper relation to forming tool without loosening bolts or nuts by operating a worm meshing with a wheel positive with the cam shaft, a micrometer stop attached to peripheral relief slide enabling the tool to be accurately reset at each change of work. The peripheral and side relief are operated by the same cam, while the end relief is operated by a separate cam at end of bed. Either collar bearings or center bearings may be used in the tailstock according to the requirements of the work.

Tools from $\frac{1}{4}$ in. to 1 in. in thickness can be held in the block which is set on a 30 deg. slide plate and operated by small handwheel at side to raise on lower tool to required adjustment. The tool is fed to the work by a handwheel provided with accurate differential control for fine feed, which is thrown out of gear when making quick adjustments. Longitudinal adjustment is obtained by a carriage screw operated by handwheel through bevel gears, the maximum adjustment being 12 in.

The machine will relieve cutters up to 13 in. dia., with flutes from 3 in. to 12 in. inclusive, the flutes being even numbers from 12 to 40 inclusive. Holes and worms can also be cut to good advantage.

When motor driven, a 3 horse-power variable speed motor is mounted at back of machine. The total weight is approximately 6,500 lbs. and floor space, 68 x 48 x 64 ins.

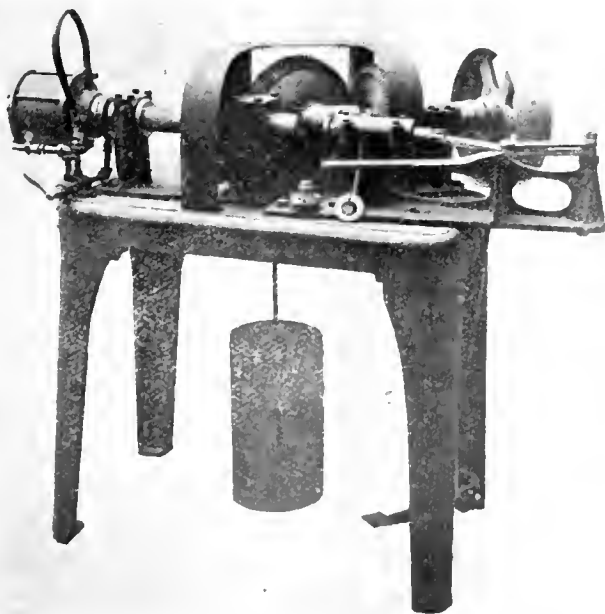

FUSE RING GRADUATING MACHINE.

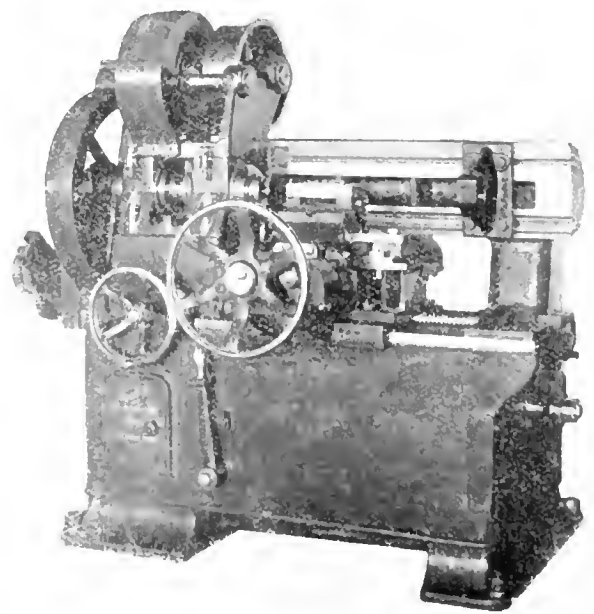

FORMED CUTTER RELIEVING MACHINE.

TRAVERSING HEAD DRILL PRESS.

AN interesting departure from regular drill press practice is shown in the accompanying photograph of a heavy duty single spindle traversing head drill press recently added to their line by the Moline Tool Co., Moline, Ill. In place of

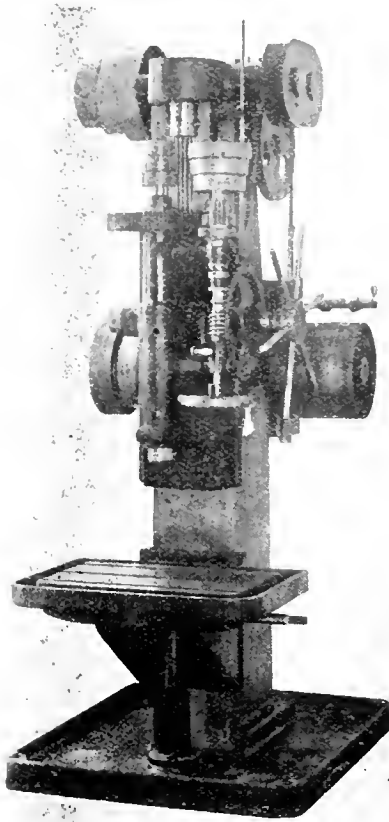

TRAVERSING HEAD VERTICAL DRILL PRESS WITH BELT FEED.

the spindle being mounted in a quill fed by rack and pinion, it is carried in long adjustable bronze bushings mounted in the head, the entire head with feed gear works being traversed up and down by a double rack and pinion.

This method of construction enables the spindle diameter to be kept large where the spindle drive gear is mounted, dispensing with the reduced spindle diameter of conventional design, which is further weakened by splining for driving keys. The spindle gear is driven by a wide faced vertical pinion, the vertical movement of the head causing the spindle gear to travel along the face of the pinion, which is supported its entire length, runs in bronze bushings, and is driven by steel and bronze spiral gearing from a three-step cone pulley. Between the pulley shaft and the spiral pinion are two sets of change gears giving speeds ranging from 20 revs. per min. to 200 revs. per min. Gear box feed can be supplied in place of belt feed shown in cut.

The principal dimensions are as follows: Centre of spindle to face of col-

umn, 10 in.; max. distance, table to spindle, 34 in., in floor type machine, 46 in.; table has three tee-slots, oil catching rim, and working face, 15 in. x 24 in.; vertical travel of table, 15 in., of head, 18 in.; spindle dia., lower bearing 2 15-16 in.; pump and piping regularly included.

**NEW LINE OF RADIAL DRILLS**

A NEWLY designed line of radial drilling machines consisting of 2½, 3 and 3½ ft. machines has been placed on the market by the Morris Machine Tool Co., Cincinnati, O. The machines embody all the necessary features of modern manufacturing tools, and are capable of driving high speed drills at their maximum speeds, as well as doing tapping, facing, counterboring, etc., with ease on the part of the operator.

A large diameter column, mounted on roller bearings, is carried on a heavily designed stump, bolted and doubled to the base, projecting into the stump sufficiently far to insure alignment under heavy strain. The deep base is well ribbed and provided with large tee slots, and oil channel round the base draining into a large reservoir.

The arm bearing on the column is wide, has adjustment for wear, and is clamped in position by a single lever. The arm itself is of pipe section with a heavy rib above and below. The arm elevating screw is operated through tumbler gears so arranged that their tendency to disengage compels the operator to keep his hand on the elevating lever while in operation. Any attempt to elevate the arm while clamped, or in extreme positions renders it impossible to keep gears in mesh. The head is of substantial construction and slides on hardened ways on the arm by rack and pinion. The spindle is a hammered forging of high carbon steel, having ball thrust bearing, and graduated sleeve fitted with direct reading depth gauge and automatic feed trip. Ten spindle speeds are secured on the cone drive machine and twelve on the speed box drive.

Steel gears are used throughout and all bearings are of phosphor bronze fitted with oil chamber and felt wiper.

C. P. R. TUNNEL THROUGH SELKIRKS

TWO important results will follow the completion of the C. P. R. Connaught tunnel in the Selkirks—first, the elimination of all danger from snowslides; second, the discontinuance of the upkeep of five miles of snowsheds. The ventilating system, which is now being installed, and which is in a very forward state, is most thorough in its layout and equipment. The desire is to keep the smoke and gases away from the engineers and firemen on the locomotives on their trip through the tunnel. The train will travel uphill from the eastern to the western end at the rate of about 20 miles an hour; but the smoke and foul air will be pushed down the hill at the rate of about 12 miles an hour—thus driving the smoke away from the engines.

The ventilating fans are driven by two oil engines, which are in duplicate against emergencies, and no effort has been spared to make the plant the most complete possible, the idea being to have the tunnel as safe from every point of view as any other part of the line. Ten or twelve minutes are required to negotiate the five miles of tunnel.



Another Bloke.—"Who was this 'ere Nero, Bill?" asked a eoster of his friend as they gazed in the picture shop. "Wasn't he a chap that was always cold?"

"No, that was Zero," was the answer. "Another bloke altogether."



British colonies total 13,002,321 square miles in area, with a population of 389,065,035.

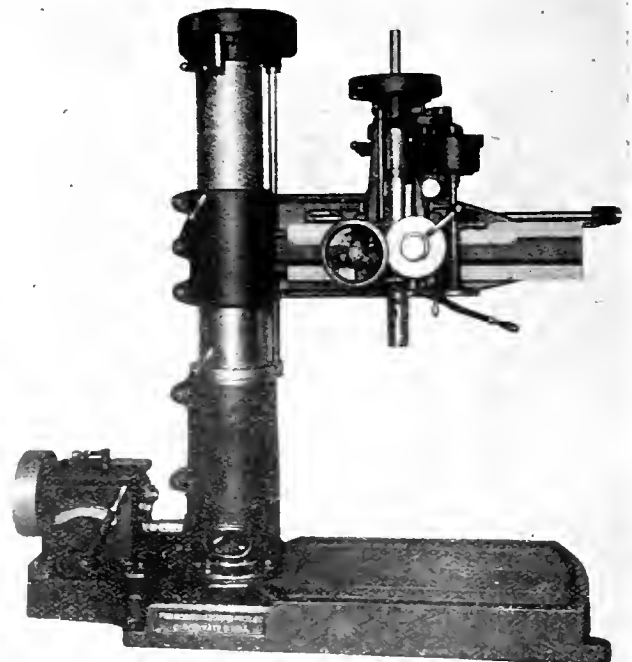

NEW MODEL RADIAL DRILL MADE IN 2½, 3 AND 3½ FT. SIZES.

The MacLean Publishing Company

LIMITED

(ESTABLISHED 1888)

JOHN BAYNE MACLEAN President
H. T. HUNTER Vice President
H. V. TYRRELL General Manager

PUBLISHERS OF

CANADIAN MACHINERY AND MANUFACTURING NEWS

A weekly newspaper devoted to the machinery and manufacturing interests.

PETER BAIN, M.E., Editor. B. G. NEWTON, Manager.
Associate Editors.

A. G. WEBSTER, J. M. WILSON, J. H. RODGERS.

Office of Publication, 143-153 University Avenue, Toronto, Ont

Vol. XVII. JANUARY 4, 1917 No. 1

OUR 1917 MUNITIONS OPPORTUNITIES

GREAT as have been our opportunities during the past two years to secure contracts for the supply of munitions to Great Britain and her Allies, and in spite of the fact that we have given evidence of a generous response as regards output, still greater opportunities are awaiting us, and, correspondingly, the onus of a very much increased production comparatively. Munition orders amounting to several hundred millions of dollars are being and will be placed with Canadian metal-working plants, in which connection it is learned from a highly authoritative source that during the past week or ten days an order for shells, variously estimated as worth from \$175,000,000 to \$200,000,000, has been placed with a prominent Montreal plant.

From time to time recently, reference has been made in our columns to the fact that, while orders for raw materials may continue to be placed in the United States, those for finished shells were on the eve of being discontinued. Notwithstanding, it was hardly believed that the transfer to Canadian metal-working plants could be carried out in toto, as is now planned, a suspicion being existent that the capacity, if not also the efficiency of the latter were unequal to the task. Further, it had been supposed that the hundreds of munition factories which have sprung up in Great Britain, France and Italy would take over the work. News that Canada has developed facilities to handle a shell business which may amount to fully \$100,000,000 during this year, has been, to say the least, some surprise, more especially when it is recalled that during 1915 and 1916, sections of numerous Canadian shell orders were placed in the States to be filled.

Several important influences have been operative to cause Allied munition buyers to switch shell-making to Canada. In the first place, of course, there is a desire to utilize the facilities of a country having a direct part in the war, whose plants and workmen will profit from the business. Another consideration is the economy to be effected in having the finished goods turned out close to the base of supplies of raw material. Whether, however, the Allied war material is made in Canada or in Europe, a great part of the steel rounds and metals used will have

to come from the United States. As completed shells can be shipped across the Atlantic cheaper than steel, copper and zinc, in the rough, it is naturally in keeping with the economic plans of the fighting nations to have munitions made up on this side of the water.

As a result of the foregoing developments, we may expect Canadian bankers to continue to furnish the necessary accommodation to our Imperial Munitions Board, in quantity commensurate with the resources at their disposal; and, on occasion, when supplementary measures become necessary, to influence by co-operative effort the successful flotation of either domestic loans or their consummation with United States bankers, thus relieving the Imperial Treasury, and adding to the strength of its credit in world markets.

As we go to press, advices reach us to the effect, that an additional \$50,000,000 credit from Canadian Banks to the Imperial Government for the purchase of munitions and supplies in Canada has been arranged, same having been under negotiation for some two weeks past. This new credit makes a total of \$250,000,000 provided by our banks and Government for the purposes mentioned, and all within the space of one year.



CANADA'S NATIONAL SERVICE WEEK

THESE, the opening days of the New Year, 1917, constitute what is known as Canada's National Service Week, and, as will be gathered from what follows, the response of our citizens to its aims and purposes is expected to be both prompt and hearty. Our men are interested because it is obligatory upon each of them, between the ages of 16 and 65 years, to fill out one of the cards which the Government is sending to them through the Post Office authorities. Our women are interested because their co-operation is being invited, in seeing that their men-folk attend to this important duty. Our children are interested because their school teachers have explained to them the meaning of National Service and the way in which father and the big brothers at home have to reply to the various questions.

To write in the answers and return the card promptly is a good New Year's resolution for every man throughout the Dominion; it has the advantage of being easy of fulfillment. It only means a few minutes' careful thought. The postman in the cities gets the hard work, for he has not only to deliver the cards, but he is responsible also for their proper return. Prompt mailing of the answers will make the postman's work very much easier.

National Service means that we are to get into that frame of mind which will cause us to think of the needs of the country, to realize that the interests of the State have a greater claim on us than our self-interest. This applies to everyone, from the highest in the land to the lowest. The Prince of Wales' motto, "I serve" may well be the motto of every citizen of the British Empire at this time. There are many ways of serving the nation besides going to the front. The man on the farm and the mechanic in a workshop may be serving the nation as usefully as the man in the trenches. In a word, every man should be doing the work which represents his most efficient service to his country.

The war is teaching us, or should be teaching us, great lessons. Terrible as are its effects, those who have faith in Canadian manhood, hope and believe that the nation will emerge from this experience, bigger, stronger and better. If the meaning of National Service is thoroughly grasped and properly understood, if the Government's call for information is responded to in the right spirit, 1917 will be the banner year in Canada's history.

SELECTED MARKET QUOTATIONS

Being a record of prices current on raw and finished material entering into the manufacture of mechanical and general engineering products.

PIG IRON.

Grey forge, Pittsburgh ..	\$29 95
Lake Superior, charcoal ..	31 75
Chicago ..	31 75
Standard low phos., Phila- delphia ..	33 00
Bessemer, Pittsburgh ..	35 95
Basic, Valley furnace ..	30 00
Montreal Toronto	
Middlesboro, No. 3 ..	38 00
Cleveland, No. 3 ..	38 00
Clarence, No. 3 ..	38 00
Hamilton ..	40 00
Victoria ..	38 00

FINISHED IRON AND STEEL.

Per lb. to Large Buyers. Cents

Iron bars, base, Toronto ..	3.50
Steel bars, base, Toronto ..	3.75
Steel bars, 2 in. and larger base ..	5.25
Iron bars, base, Montreal ..	3.35
Steel bars, base, Montreal ..	4.00
Twisted reinforcing bars, base ..	3.55
Bessemer rails, heavy, at mill ..	3.50
Steel bars, Pittsburgh ..	3.35
Tank plates, Pittsburgh ..	3.75
Beams and angles, Pitts- burgh ..	3.50
Steel hoops, Pittsburgh ..	3.50
F.O.B. Toronto Warehouse.	
Cents	
Steel bars, base ..	3.65
Small shapes ..	3.85
F.O.B. Chicago Warehouse	
Cents	
Steel bars ..	3.60
Bars, 2 in. and up ..	4.00
Structural shapes ..	3.50
Plates ..	4.35

FREIGHT RATES.

Pittsburgh to Following Points	
Per 100 lbs.	
C.L.	L.C.L.
Montreal ..	23.1 31.5
St. John, N.B. ..	35.1 45.5
Halifax ..	35.1 45.5
Toronto ..	18.9 22.1
Guelph ..	18.9 22.1
London ..	18.9 22.1
Windsor ..	18.9 22.1
Winnipeg ..	64.9 85.1

METALS.

Montreal Toronto	
Lake copper, car- load ..	\$36 00 \$38 00
Electrolytic cop- per ..	36 00 38 50
Castings, copper ..	35 00 37 50
Tin ..	46 00 47 00
Spelter ..	13 50 13 50
Lead ..	10 00 9 50
Antimony ..	15 00 18 00
Aluminum ..	19 00 18 00

Prices per 100 lbs.

BOILER PLATES.

Montreal Toronto	
Plates, 1/4 to 1/2 ..	\$5 00 \$5 00
Heads ..	5 35 5 25
Tank plates, 3-16 in. ..	5 25 5 25

WROUGHT PIPE.

Prices in effect Dec. 6, 1916.

Buttweld.		
Per 100 feet	Black.	Galv.
3/8 in. ..	\$ 4 00	\$ 5 50
1/2 in. and 3/4 in. ..	3 42	5 55
1 1/2 in. ..	4 42	5 99
3/4 in. ..	5 41	7 53
1 in. ..	7 99	11 14
1 1/4 in. ..	10 51	15 07
1 1/2 in. ..	12 93	18 01
2 in. ..	17 39	24 24
2 1/2 in. ..	27 50	38 82
3 in. ..	35 96	50 11
3 1/2 in. ..	45 08	62 10
4 in. ..	53 41	73 58

Lapweld.

2 in.	\$ 20 35	\$ 26 83
2 1/2 in.	30 42	40 66
3 in.	39 78	53 17
3 1/2 in.	49 68	66 70
4 in.	58 86	79 03
4 1/2 in.	68 58	92 08
5 in.	79 92	107 30
6 in.	103 70	139 26
7 in.	138 00	182 16
8 in. x 25 lbs. per ft.	145 00	191 39
8 in. x 25 lbs. per ft.	167 00	220 39
9 in.	200 10	263 90
10 in. x 32 lbs. per ft.	185 60	244 80
10 in. x 40 lbs. per ft.	239 00	315 00

List for Ontario, Quebec and Maritime Provinces.

OLD MATERIAL.

Dealers' Buying prices.

Montreal Toronto	
Copper, light ..	\$21 00 \$23 50
Copper, crucible ..	25 00 27 00
Copper, heavy ..	25 00 27 00
Copper wire ..	25 00 27 00
No. 1 machiae composition ..	20 50 22 00
No. 1 composition turnings ..	16 50 19 00
New Brass clip- pings ..	17 00 19 00
No. 1 brass turn- ings ..	15 25 16 00
Steel, low phos. ..	14 00 18 00
Heavy Melting steel ..	13 00 14 00
No. 1 machine cast iron ..	15 00 16 00
Steel turnings ..	7 00 7 00
Boiler plate ..	12 00 10 50
Rails ..	14 75 15 00
Axles, wrought iron ..	19 00 24 00
Tires, steel ..	12 00 11 00
Rails ..	13 75 14 00
Shafting ..	16 75 20 00
Malleable scrap ..	10 25 11 00
Pipe, wrought ..	10 50 9 00
Stove plate ..	12 00 12 50
Heavy lead ..	7 50 7 75
Tea lead ..	6 00 5 50
Scrap zinc ..	8 00 8 50
Aluminum ..	35 00 35 00

BOLTS, NUTS AND SCREWS.

	Per Cent.
Coach and lag screws ..	35
Stove bolts ..	55
Plate washers ..	20
Machine bolts, 7-16 and over ..	15
Machine bolts, 3/4 and less ..	25
Blank bolts ..	15
Bolt ends ..	15
Machine screws, fl. and rd. hd., steel ..	27 1/2
Machine screws, o. and fl. hd., steel ..	10
Machiae screws, fl. and rd. hd., brass ..	net.
Machine screws, o. and fl. hd., brass ..	net.
Nuts, hex., up to 1 in. ..	\$3.75
per lb. off.	
Nuts, hex., over 1 in. ..	\$2.00
per lb. off.	
Copper rivets and burrs, list plus ..	30
Burrs only list plus ..	50
Iron rivets and burrs ..	30
Boiler rivets, base 3/4-in. and larger ..	\$5.25
Structural rivets, as above ..	5.15
Wood screws, flat, bright ..	.75
Wood screws, O. & R., bright ..	.70
Wood screws, flat, brass ..	.42 1/2
Wood screws, O. & R., brass ..	.40
Wood screws, flat, bronze ..	.35
Wood screws, O. & R. bronze ..	.22 1/2

MILLED PRODUCTS.

	Per Cent.
Set screws ..	40
Sq. & Hex. Head Cap Screws ..	30
Rd. & Fil Head Cap Screws ..	15
Flat & But. Hd. Cap Screws plus ..	15
Fin. & semi-fin. nuts up to 1 in. ..	30
Fin. and semi-fin. nuts, over 1 in. ..	25
Studs ..	15
Taper plus ..	45
Coupling bolts, plus ..	15
Planer head bolts, without fillet ..	15
Planer head bolts, with fillet ..	net
Planer head bolt nuts, up to 1 in. ..	30
Planer head bolt nuts, over 1 in. ..	25
Planer bolt washers, plus ..	10
Hollow set screws, list plus ..	40
Collar screws ..	20
Thumb screws ..	20
Thumb nuts ..	70
Patch bolts ..	65
Cold pressed nuts to 1 1/2 in. ..	add 3.50
Cold pressed nuts over 1 1/2 in. ..	add \$2.00

BILLETS.

Per gross ton	
Bessemer billets, Pitts- burgh ..	\$85 00
Open-hearth billets, Pitts- burgh ..	55 00
O.H. sheet bars, Pittsburgh ..	55 00
Forging billets, Pittsburgh ..	80 00
Wire rods, Pittsburgh ..	70 00

NAILS AND SPIKES.

Standard steel wire nails, base ..	\$4 75 \$4 70
Cut nails ..	4 00 4 00
Miscellaneous wire nails ..	65%
Pressed spikes, 5/8 diam., 100 lbs. ..	\$4 10

MISCELLANEOUS.

Solder, guaranteed ..	0 30
Solder, strictly ..	0 27
Rabbit metals ..	11 to 60
Soldering coppers, lb. ..	0 53
Patty, 100-lb. drums ..	3 00
White lead, pure, cwt. ..	14 25
Red dry lead, 100-lb. kegs, per cwt. ..	13 87
Glue, French medal, lb. ..	0 25
Tarred slaters' paper, roll ..	0 95
Gasoline, per gal., bulk ..	0 27 1/2
Benzine, per gal., bulk ..	0 26 1/2
Pure turpentine, single bbls., gal. ..	0 71
Linseed oil, raw, single bbls. ..	1 12
Linseed oil, boiled, single bbls. ..	1 15
Plaster of Paris, per bbl. ..	2 50
Plumbers' oakum, per cwt. ..	8 00
Packing, square headed ..	0 25
Packing, No 1 Italian ..	0 30
Packing, No 2 Italian ..	0 23
Lead wool, per lb. ..	0 12
Pure Manila rope ..	0 25 1/2
Transmission rope, Manila ..	0 29 1/2
Drilling cables, Manila ..	0 27 1/2

POLISHED DRILL ROD.

Discount off list, Montreal and Toronto ..	25%
---	-----

CARBON DRILLS AND REAMERS.

	Per Cent.
S.S. drills, wire sizes ..	35
S.S. drills, 1 1/8 in. and larger ..	50
Standard drills to 1 1/2 in. ..	50
Standard drills, over 1 1/2 in. ..	20
3-fluted drills to 1 1/2 in. ..	20
3-fluted drills, over 1 1/2 in. ..	10
Bit stock ..	50
Ratchet drills ..	20
Machine bits for wood ..	15
S.S. drills for wood ..	45
Wood boring brace drills ..	35
Electricians ..	25
Sockets ..	30

Sleeves ..	40
Taper pin and taper reamers ..	30
"Premier" and "Leader" chucks ..	10
Arbors for above ..	net
Drills and countersinks ..	list plus 30
Bridge reamers ..	55
Centre reamers ..	10
Chucking reamers ..	10
Hand reamers ..	15
High-speed drills up to 1 1/2 in. and over 1 1/2 in. are now double list.	

COLD ROLLED SHAFTING.

At mill ..	list plus 40%
At warehouse ..	list plus 50%
Discounts off new list. Ware- house price at Montreal and Toronto.	

IRON PIPE FITTINGS.

Canadian malleable, A. add 5%; B and C. 12%; cast iron, 40; standard bushings, 50%; headers, 60; flanged unions, 45; malleable bushings, 50; nipples, 70; malleable flanged unions, 55.	
--	--

SHEETS.

Montreal Toronto	
Sheets, Black, No. 28, 85 00 ..	\$5 00
Sheets, black, No. 10 5 50 ..	5 50
Canada plates, dull, 52 sheets ..	5 75 5 75
Canada plates, all bright ..	6 50 6 50
Apollo brand, 10 3/4 oz. galvanized ..	7 25 7 25
Queen's Head, 28 B. W.G. ..	7 75 7 75
Fleur-de-Lis, 28 B.W. G. ..	7 45 7 35
Gorbals Best, No. 28 ..	7 75 7 50
Colborne Crown, No. 28 ..	7 25 6 75
Premier, No. 28 U.S. ..	6 70 7 20
Premier, 10 3/4 oz. ..	7 00 7 50

PROOF COIL CHAIN.

1/4 in.	\$9 45
5-16 in.	9 10
3/8 in.	8 35
7-16 in.	7 15
1/2 in.	6 95
9-16 in.	6 95
5/8 in.	6 80
3/4 in.	6 70
7/8 in.	6 55
1 inch ..	6 40
Above quotations are per cwt.	

ELECTRIC WELD COIL CHAIN B.B.

1 1/2 in.	\$15 50
3-16 in.	11 70
1/4 in.	8 40
5-16 in.	7 40
3/8 in.	6 35
7-16 in.	6 35
1/2 in.	6 35
5/8 in.	6 35
3/4 in.	6 35

FILES AND RASPS.

	Per Cent.
Great Western, American ..	60
Kearney & Foot, Arcade ..	60
J. Barton Smith, Eagle ..	60
McClelland, Globe ..	60
Black Diamond ..	50
Delta Files ..	47 1/2
Nicholson ..	50
Globe ..	57 1/2
Vulcan ..	57 1/2
Disston ..	60

COAL AND COKE.

Solvay Foundry Coke ..	
JCCr. C.C. 2 .0 00% & C	
Connellsville Foundry Coke ..	
Yough Steam Lump Coal ..	
Pittsburgh Steam Lump Coal ..	
Best Slack ..	
Net ton f.o.b. Toronto	

BOILER TUBES.			TAPES.		ANODES.		ft.	
Size.	Seamless	Lap-welded	Chesterman Metallic, 50 ft.	\$2 00	Nickel	.50 to .54	11 75	12 25
1 in.	\$30 00	Lnfkin Metallic, 603, 50 ft.	2 00	Cobalt	1.75 to 2.00	Sheets, 4 to 6 lbs.
1 1/4 in.	30 00	Admiral Steel Tape, 50 ft.	2 75	Copper	.44 to .46	sq. ft.	11 50 12 00
1 1/2 in.	30 00	24 00	Admiral Steel Tape, 100 ft.	4 45	Tin	.49 to .56	Cut sheets, 1/2c per lb. extra.	
1 3/4 in.	29 00	21 00	Major Jun. Steel Tape, 50 ft.	3 50	Zinc	.23 to .25	Cut sheets to size, 1c per lb extra.	
2 in.	33 00	20 00	Rival Steel Tape, 50 ft.	2 75	Prices Per Lb.			
2 1/4 in.	33 00	Rival Steel Tape, 100 ft.	4 45	COPPER SHEETS.			
2 1/2 in.	35 75	26 50	Reliable Jun. Steel Tape, 50 ft.	3 50	Montreal Toronto			
3 in.	48 50	30 00	WASTE.		Bars, 1/2 to 2 in. \$46 00 \$46 00			
3 1/4 in.	54 50	36 00	White Cents per lb.		Plain sheets, 14 oz. 14x28 in., 14x60 in 45 00 45 00			
3 1/2 in.	59 50	30 00	XXX Extra	18	Copper sheet, tinned, 14x60, 14 oz. 54 00 54 00			
4 in.	65 50	49 00	Peerless	18	Copper sheet, plain-ished, 14x60 base, 57 00 57 00			
Prices per 100 Feet, Montreal and Toronto.			Grand	17	Braziers' in sheets, 6x4 base 46 50 46 50			
OILS AND COMPOUNDS.			Superior	17	BRASS.			
Castor oil, per lb.	23		X L C R	16	Brass rods, base 1/2 in to 1 in rd. 0 55			
Royalite, per gal., bulk	11		Atlas	16	Brass sheets, 8 in. wide, 20 oz. 0 60			
Machine oil, per gal.	26 1/2		X Empire	15	Brass tubing, seamless... 0 55			
Black oil, per gal.	14 1/2		Ideal	15	PLATING SUPPLIES.			
Cylinder oil, Capital	47 1/2		X press	14	Polishing wheels, felt, 2 10			
Cylinder oil, Acme	38 1/2		COLORED.		Polishing wheels, bull-neck 1 35			
Standard cutting compound, per lb.	0.6		Lion	12 1/2	Emery in kegs, American 06			
Lard oil, per gal.	1.35		Standard	11	Pumice, ground 04			
Thread cutting oil	35		No. 1	11	Emery glue 15 to 20			
Union thread cutting oil antiseptic	70		Popular	10	Tripoli composition 04 to 06			
Acme cutting oil, antiseptic	39 1/2		Keen	09	Crocus composition 07 to 08			
Imperial quenching oil	39 1/2		WOOL PACKING.		Emery composition 08 to 09			
Petroleum fuel oil	12 3/4		Arrow	24	Rouge, silver 35 to 50			
BELTING—NO. 1 OAK TANNED.			Axle	18	Rouge, powder 30 to 35			
Extra heavy, single and double	30-10%		Anvil	14	Prices Per Lb.			
Standard	40%		Anchor	11	LEAD SHEETS.			
Cut leather lacing, No. 1.	\$1 40		WASHED WIPERS.		Montreal Toronto			
Leather in sides	1 20		Select White	12	Sheets, 3 lbs. sq. ft. \$12 00 \$12 50			
			Mixed colored	10	Sheets, 3 1/2 lbs. sq.			
			Dark colored	09	Prices Per Lb. Unless Otherwise Stated.			
			This list subject to trade discount for quantity.					
			RUBBER BELTING.					
			Standard	50%				
			Best grades	30%				

The General Market Conditions and Tendencies

This section sets forth the views and observations of men qualified to judge the outlook and with whom we are in close touch through provincial correspondents

Montreal, Que., Dec. 30.—The action of the Allies in counteracting Germany's peace manoeuvre, coupled with the recent decision of the British Government to place an ever-increasing proportion of munitions contracts in Canada are the two most significant events influencing business at the close of the year. The former of these events imparts a more definite and decisive atmosphere to all activities connected with the conduct of hostilities, the ultimate result of such a decision tending to maintain prices firmly at present high levels but without the prospect of any further spectacular advances. The latter event insures a high degree of productive activity in nearly all branches of Canadian industry. In the iron and steel industries considerable inconvenience has been caused by car shortage and weather conditions interfering with the supply of raw materials, while business in certain metals has been directly affected by the recent censorship of shipping news.

Pig Iron

Prices continue strong but a tendency to reform further buying in some quarters has eased the situation slightly and prevented further advances in price which were becoming altogether too frequent for a satisfactory state of affairs.

Steel

Billets and sheet bars are still in heavy demand and Pittsburgh quotations have been advanced from \$3 to \$5 per ton, the nominal price being \$65 per ton. The extreme demand for wire rods has resulted in a sharp advance, the quotation of \$80 per ton, being an advance of \$10 during the week. Forging billets show a similar advance the nominal price being \$85 per ton. Black sheets have moved upwards to \$5.50 Pittsburgh an advance of \$10 per ton. Galvanized sheets at a corresponding advance are quoted at \$7.00 Pittsburgh

Metals

The general situation is rather unsettled owing to the current political developments, both here and abroad. The action of Great Britain in more closely controlling the distribution of material for manufacturing purposes, together with the restriction of shipping information has resulted in placing the trade in a somewhat nervous and uncertain condition.

Copper.—The market is quiet and unsettled. Quotations are lower on the British market, following the action of the authorities in curtailing the use of this metal. A census of copper is being made to determine the amount of metal, both stock and on contract, that is avail-

able, with a view of more economical use of the supply and to regulate the future consumption. New York quotations are lower, the price of lake, after a decline of 1/2c, being 31 1/2c per lb. Electrolytic at the same price shows a decline of 1 1/2c. Dealers here report a quiet market and a weakening tendency, the quotations this week having declined 1c per lb. Prices this week are 36c for lake and electrolytic, and 35c for castings.

Tin.—The market has been disturbed by the action of the British Government in restricting the publication of information regarding shipping movements. This will mean that the trade will experience much uncertainty as to the amount of tin in transport and will consequently result in an unsteady market. Both London and New York have declined on price quotations, the latter quoting 40 3/4c, a drop of one cent on the week. The situation here is comparatively firm but developing a weaker tendency. Tin is nominally 46c per lb.

Spelter.—The market though easier is showing a firmer tone, having become more active during the past week. However the situation in this metal is largely affected by current conditions and the early future is an unknown factor. All markets are lower, New York having declined 1/2c, the nominal quotation being now 9 3/4c per lb. The local situation is quiet and prices have declined 1/2c; the quotation this week being 13 1/2 cents per lb.

Lead.—The market remains firm but quiet, although not sufficient to affect the current quotations. Should the uncertainty that prevails continue, the

situation will probably develop a weaker tendency. The firmness of the present market is partly due to a temporary scarcity. New York continues to quote 7½¢ on "Trust" metal with the outside interests ½¢ higher. Dealers here are still quoting 10¢ but would not be surprised to see an early decline.

Antimony.—In common with other metals, antimony is experiencing a dull period owing to existing conditions. Quotations are however holding firm, prices here being steady at 15¢ per lb.

Aluminum.—The market is unchanged but with an easier tendency. Dealers here are quoting 69¢ being a decline of 1¢ per lb.

Machine Tools and Supplies

The holiday season has been reflected in a decrease in machine tool activity, and added to this the situation is partly affected by the indefinite knowledge of early future conditions. However the nervous feeling is somewhat offset by the ever increasing volume of domestic inquiry that tends to develop into greater proportion with the assurance of ultimate peace possibilities.

Scrap

Following the quiet of the past week or so, the quotations on old materials have become easier, more especially on the metals; the strength of iron and steel scrap being well maintained although a weakness has developed in some lines. Coppers have fallen off 1½¢ per lb., the quotation ranging from 21¢ for light to 25¢ for heavy and erneble. Machine compositions and turnings are 1½¢ lower, prices being 20½¢ and 16½¢ respectively. Brass clippings are now 17¢, and scrap zinc 8¢; both having declined ¼¢ per lb.

Toronto, Ont., Jan. 2.—The refusal of the Allies to enter into peace negotiations at the present time will help to clear the air of business uncertainty recently in evidence.

The year just closed has been one of remarkable prosperity for Canada, and this new year, so far as can be seen at the present time, promises to eclipse its immediate predecessor. Many industries have developed to such an extent that variety of output as well as volume has increased to a surprising extent. There has been a remarkable expansion in export trade, while Customs revenues have also made a big increase. For December the Customs revenue amounted to \$11,884,000, as compared with \$9,432,000 for the corresponding month of last year. In the nine months of the fiscal year the Customs revenue has reached a total of \$106,613,000, an increase of \$34,891,000.

Steel

The market has been quiet during the holiday season, as is usually the case, consequently there are no price changes to note. The New Year opens with the iron and steel trade in a sound position, with a year of big business undertaken and good prospects for another twelve months, or at the least a good part of it,

of at least equal activity. Much depends, of course, upon the duration of the war, but the mill's are already assured of practically twelve months' business, it being unlikely that any contracts now placed will be cancelled. If peace be declared during the year, it is more than likely that the tonnage will be delivered in some form other than munitions. The productive capacity of the mills has been greatly increased and requires a corresponding increase in volume of business to keep them operating at capacity. To what extent this output will be required after the war is a matter of speculation, but it is there to be taken advantage of, if needed. While there will probably be a subsidence of peace talk for some months, prices may be subject to more or less disturbance. The situation in the steel trade at present is similar to that of last June, when it was generally thought that prices had about reached the top. Whether the upward movement has stopped or not is a matter of conjecture, but there is little doubt that the peace talk has already affected the market to some extent, and that it will help to check any upward tendency in prices. Some steel products, such as black sheets and plates, are expected to reach higher levels regardless of the general trend of the market, as the situation in each is rather exceptional.

As regards black sheets, the mills are experiencing a shortage of sheet bars, while the scarcity of labor is helping to curtail the sheets output. Most large sheet mills have no material to offer for first quarter delivery, while some have made fairly large sales for second quarter. The leading interest in the U. S. has advanced prices which will affect the local situation in due course. The demand for plates continues heavy, and most mills are sold up for the whole of 1917. The market for wire rods continues very firm at advancing prices. It is understood that Canadian interests have paid \$80 a ton at mill for wire rods in the U. S.

Pig Iron

The pig iron market is quieter, and no further price changes have been made. Prices on domestic brands of pig iron are still withdrawn, and no intimation has been made as to when new prices are likely to be issued. The pig iron market in the States is quieter, buying being lighter owing to limited amounts of iron available and congested freight conditions. There have been no price changes in the U. S. on pig irons.

Machine Tools

There is a seasonable quietness in the machine tool market, the transactions this week having been comparatively light. Renewed activity is, however, looked for this month, principally in equipment for munition plants. Prices of machine tools continue to advance, affecting particularly lathes, drilling machines and power presses. A firm in the U. S. has advanced prices 12½ per cent. on 12-in. to 30-in. lathes, making quotations now 65 per cent. higher than two

years ago. Drilling machines, including radial and upright drills, have advanced 10 per cent. recently, making prices about 50 per cent. higher than two years ago. On power presses the advances range from 5 to 10 per cent., making quotations about 50 per cent. higher than two years ago.

Supplies

On account of the holidays, business has been quiet during the week. It is understood that new and higher prices on lubricating oils will be announced very shortly, due, it is stated, to the higher cost of crude oil, which has recently advanced. Gasoline is unchanged in the meantime, but very firm. Pennsylvania crude oil advanced 10¢ a few days ago, and is now quoted at \$2.85 a barrel, Pittsburg, the highest price ever quoted for this grade. Other grades were each advanced 5¢. The advances were brought about by the continued demand of refiners, who state that there is an abundance of oil above ground, but producers are holding it for still higher prices. Jenkins globe, angle, and cheek valves have advanced approximately 7½ per cent., the new discount being 15 per cent. on standard grade. Gate valves are now selling at 20 per cent. off list. Iron body gate and globe valves are quoted at 40 per cent. off.

Metals

The metal market has been seasonably quiet this week on account of the holidays and stock-taking. The situation with regard to most metals is unchanged, and prices are the same as were recorded last week. The temporary passing of peace talk will tend to make the markets firmer, but any pronounced upward movement in any metal is very unlikely. The possibility of peace proposals being renewed later on in the year will tend to check any tendency to inflated prices.

Copper.—The market is steadier, but quiet. Producers, in view of their sold-up condition, have not changed their quotations for any part of the first half. There is practically no spot copper to be had except resale metal, which has been quoted under the market. Local prices are unchanged and nominal at 36¢ per pound.

Tin.—The market is dull and unsettled, although there has been no change in prices. The action of the British Government in prohibiting the publication of steamship arrivals and departures has affected the tin market, as the movements of tin cargoes cannot be followed by the trade. Local price, 45¢ per pound.

Spelter.—There has been no change in the spelter situation at the mines; the market is steadier and quiet. Local price, 13¢ per pound.

Lead.—There is some scarcity of lead, but quotations are unchanged, with the market quiet. Local price, 9½¢ per pound.

Antimony.—The market is very dull, with prices nominal and unchanged at 18¢ per pound.

Aluminum.—The situation is unchanged, but the market has an easier tendency. Local price, 68¢ per pound.

ELECTRIC MOTORS?

PHONE MOTOR DEPARTMENT

ADELAIDE 20

In Toronto and at all our branch warehouses we carry very complete stocks of Electric Motors, Dynamos and Portable Electric Tools of all kinds.

Just now we have large stock orders placed for 3-phase, 25-cycle Motors, and can in this way very often give you better deliveries than manufacturers themselves. We give special attention to all apparatus required in the nature of Electric Motor power, and can give you expert advice on all your Electrical Problems. Write us.

The A. R. WILLIAMS MACHINERY CO., LIMITED

64-66 Front Street West

TORONTO, CANADA

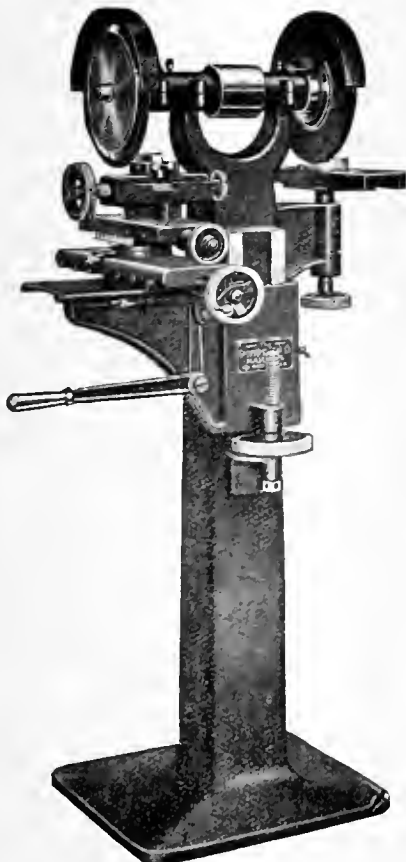

Proper Grinding or Sharpening

of Thread Chasers will keep all chasers of a set in condition for perfect work, and at the same time prevent excessive wear on one or two of the chasers.

The Geometric Chaser or Die Grinder

is a machine carefully designed and constructed for the correct grinding of thread chasers and dies. Its use is economy where threading tools are employed.

The Geometric grinds any make of thread chaser, whether of a stock or special type. Also fitted with a second grinding wheel for ordinary tool grinding.

SEND FOR DESCRIPTIVE BOOKLET.

The Geometric Tool Company

New Haven, Conn., U.S.A.

Canadian Agents: Williams & Wilson, Ltd., Montreal; The A. R. Williams Machinery Co., Ltd., Toronto, Winnipeg and St. John, N.B.

If any advertisement interests you, tear it out now and place with letters to be answered.

INDUSTRIAL ^A_N^D CONSTRUCTION NEWS

Establishment or Enlargement of Factories, Mills, Power Plants, Etc.; Construction of Railways, Bridges, Etc.; Municipal Undertakings; Mining News

ENGINEERING

Toronto, Ont.—The Gutta Percha & Rubber Co. will build an extension to their power house.

Toronto, Ont.—The Wm. Davies Co. will build a smoke house addition to their plant at 529 Front Street, to cost \$3,000.

Toronto, Ont.—A building permit has been granted to the Consolidated Steel Co. for the construction of a machine shop at 1154 Dundas Street, to cost \$2,500.

GENERAL INDUSTRIAL

Montreal, Que.—The Canadian Starch Co. will build an addition to their factory at Cardinal, Ont.

Tillsonburg, Ont.—The Huntley Mfg. Co., Silver Creek, N.Y., builder of cereal-milling and canning machinery, has purchased a site here and will build a factory.

Toronto, Ont.—Fire on December 28 destroyed the King Street car barns of the Toronto Street Railway Co., causing damage estimated at over \$500,000, which is covered by insurance. About 70 cars were destroyed and a portable air compressor outfit.

MUNICIPAL

Port Arthur, Ont.—A by-law to renew a power contract with the Hydro-Electric Commission was carried by 780 to 20.

Clinton, Ont.—The waterworks extension by-law was carried here on Monday by a majority of 4 to 1, and the Hydro by-law by 2 to 1.

Oshawa, Ont.—At the elections on Monday, the by-law to vote a bonus to the McCulloch Foundry was carried by a majority of 62.

Palmerston, Ont.—The Hydro-Electric by-law to acquire and develop more power was carried six to one, only 11 voting against it.

Amherst, N.S.—The Town Council contemplate the purchase of a motor-driven centrifugal pump in connection with the waterworks system.

Ganoque, Ont.—The voting on the by-law granting the Steel Co. of Canada the present fixed assessment for ten years resulted as follows:—For, 247; against, 192.

Seaforth, Ont.—Two by-laws were voted upon here on Monday. The Jackson Clothing Co. by-law was defeated, standing 49 for, 132 against. The firm asked \$250 a year for ten years to operate a branch factory here.

Brantford, Ont.—The City Council contemplate installing a mechanical filtration plant.

Ottawa, Ont.—At the elections on Monday, the ratepayers voted \$50,000 for a civic garbage collection plant and \$75,000 for public swimming baths.

Lindsay, Ont.—The by-law to allow a fixed assessment on the new plant of Flavelles, Ltd., cold storage and egg house was passed by a very large majority.

Toronto, Ont.—The Township of Etobicoke propose to construct a waterworks system at an approximate cost of \$75,000. E. A. James, of Toronto, is the consulting engineer.

Woodstock, Ont.—The result of the vote on the Hydro by-law resulted in an overwhelming majority for the by-law of over 900, very little opposition being shown. The vote stood—1,025 for, 7 against.

Walkerville, Ont.—The by-law empowering the Town Council to consider the deal with transportation problems in the municipality was carried by a large majority, as was also the Hydro-Electric by-law.

Toronto, Ont.—At the elections on January 1, the vote in favor of the municipal ownership of the Hydro development generation plant was overwhelmingly large; out of a total vote of nearly 22,000 only 1,566 people voted against the proposition.

Toronto, Ont.—The Board of Control recommends that the Works Department be authorized to purchase the following supplies during 1917 in the open market: Iron and steel, pig lead, paving pitch, pipe and boiler tubes, rubber valves, etc.

Owen Sound, Ont.—The ratepayers voted on Monday on by-laws to loan the Keenan Woodenware Mfg. Co. \$20,000 to extend their plant and to authorize the purchase of a motor truck for the Fire Department. The Keenan by-law carried, 923 to 152, while the motor truck proposition was defeated by 433 to 566.

Bridgeburg, Ont.—All the by-laws for the Welland, Port Colborne & Bridgeburg Radial Railway carried on Jan. 1 by large majorities, probably five to one. Fort Erie was considered a doubtful point, but there were only eight votes against it there. Humberstone Township carried it by four to one.

Chatham, Ont.—The Hydro extension by-law and the Patriotic Fund by-law, the latter providing for raising \$600,000 for the Patriotic Fund by taxation this year, were both carried with large majorities. The fire truck by-law was defeated at the municipal election on January 1.

Brantford, Ont.—At the elections on Monday, two by-laws, one as to a proposition to develop the question of a municipally owned gas plant to be placed before the people, and one giving the city authority to enter into the Chippewa power development scheme, were carried by big majorities.

London, Ont.—On January 1 the industrial bond guarantee by-law, covering a scheme for the inducement of industries to locate here after the war, was given a majority of 999, but will not become operative because a two-thirds majority, which was necessary, was not secured. The vote stood—2,886 for and 1,887 against.

Hamilton, Ont.—At the elections on Monday, seven by-laws were submitted to the people, with the following results: The plebiscite on the question of Hydro-Electric power development was carried; that to raise \$50,000 for improvements at the Mountain Sanitarium was carried by a large majority; that to endorse the expenditure of \$6,000,000 on the Hydro-Radial Railway prospect was lost by a small majority; to expend \$25,000 on filling in the Sherman Avenue inlet, defeated; to expend \$61,000 on the construction of a storm sewer, defeated by a large majority; to expend \$362,500 on steam pump at the waterworks station, negatived.

TRADE GOSSIP

Marine Insurance Raised.—The *Daily News*, London, England, says that owing to the increased submarine menace, the Government War Risk Insurance Office has raised the insurance rate per voyage for British vessels to forty shillings per cent.

Prohibition Raised.—C. Hamilton Wickes, his Majesty's Trade Commissioner in Canada and Newfoundland, has received the following cable from the British Government's Board of Trade, London:—"Strontium compounds and mixtures prohibited United Kingdom. 19th December, various fibres and jute piece goods, threads, yarns, twist webbing no longer prohibited."

Toronto, Ont.—The Royal Securities Corporation has become associated with the financing of the Mattagami Pulp & Paper Co., to develop the resources of this concern, which owns 125 square miles of freehold timber limits on the Mattagami River, Northern Ontario, estimated to contain over 4,000,000 cords of spruce pulpwood. For over a year the company has had under construction a sulphite pulp plant, capable of producing 45,000 tons. S. R. Armstrong has been appointed manager.

The S. K. F. Ball Bearing Co., Hartford, Conn., are reorganizing their Canadian branch the S. K. F. Ball Bearing Co., and have opened offices at 47 King Street West, Toronto.

The Michipicoten Power & Paper Co., which has recently been incorporated with a capital of \$6,500,000 propose to build a 150 ton news print mill at Michipicoten Harbor on Lake Superior. L. M. Wood of Toronto is president of the company.

Canada's Revenue Increase.—The close of the calendar year 1916, found the revenue of Canada well in advance of the receipts for 1915. The Customs revenue for the December just closed amounted to \$11,884,000, as compared with \$9,432,000 for the corresponding month in 1915, an increase of \$2,451,000. In the nine months of the fiscal year the Customs revenue has reached a total of \$106,613,000 an increase of \$34,891,000.

Marine Insurance Higher.—It is reported from New York that marine insurance rates on Dec. 30, showed another increase. Underwriters quoted 6 to 8 per cent. for insurance of cargoes bound to ports of the United Kingdom and 10 per cent. to Mediterranean ports. A few days ago these rates stood at 5 to 8 per cent. The advance was attributed to reports that the Lamport & Holt lines Voltaire, long overdue, had been captured.

Absence of Labor Troubles.—The year 1916 ended with practical immunity from labor troubles in Canada. Only one Board of Conciliation has been sitting of late, and its report was recently submitted. It deals with the application of employees of the Ottawa city water-works for a 15 per cent. increase. The Board unanimously recommends individual increases, which amount to ten per cent. in every case, and in some instances to more than 15 per cent. Forty-five employees of long standing are affected.

Russian Language at McGill.—McGill University is offering during the last half of the present session a course in the Russian language. This is the first time that instruction in Russian has been given by any Canadian University. It is an interesting departure, as indicating that the present war alliance is destined to develop into a permanent relationship of commercial intercourse. The present course is designed for beginners and is meant to meet the needs of business men as well as of students of language and literature. Full information about the class can be had on application, in writing or by telephone, to the Registrar of the University.

New Brunswick Lumber.—New Brunswick lumber production for the calendar year 1915 amounted to 635,518,000 feet, board measure, compared with 414,808,000 in 1914. These figures were obtained from 240 active mills. In the production of spruce, balsam, fir, white pine, and many of the minor classes of lumber in New Brunswick, the returns show a considerable increase in 1915 over 1914. In the quantity of hemlock sawn there was

**"HAWK" D
CHROME
VANADIUM
STEEL**



Will
Give You
Exceptional

Shell Forging Production

**WITHOUT AN EQUAL FOR
BOTH FIRST AND
SECOND OPERATION
PUNCHES.**

Comes to you heat-treated and ready for use.

It does not stick to the work.

There are many cases where each punch has turned out over 2,000 shells.

It means more shells, per machine per day.

**STEEL OF EVERY
DESCRIPTION.**

**Hawkrige Brothers
Company**

303 Congress St., BOSTON, MASS.
U. S. A.

HAVE YOU

read pages 66 to 71?
Turn to them now
and see for yourself
whether or not they
are of interest.

Canadian Machinery
Classified Advertising Section

"PURO - FY"

(MADE IN CANADA)

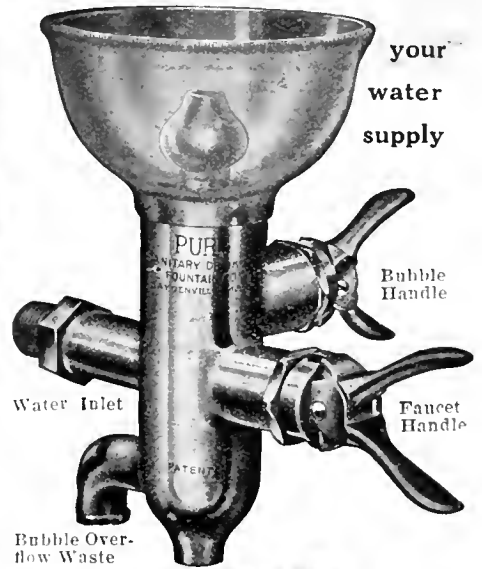

Water Inlet
Bubble Over-flow Waste

THE American Museum of Safety conferred a Gold Medal Award upon the Puro Sanitary Drinking Fountain at the First International Exposition of Safety and Sanitation. The Puro Sanitary Drinking Fountain won because it deserved to win—Puro had merits that made it stand head and shoulders above any other drinking apparatus.

**Safe Simple
SANITARY Economical
Quickly Attached**

These are the qualities that forced the leading safety and sanitary engineers to pick Puro in preference to all others.

No device can be as efficient that does not contain all these qualifications; and Puro was not tied for first place; Puro was first.

Don't be satisfied with half-way goodness, or makeshift drinking arrangements for your employees.

If the men in your factory must drink, give them a clean drink.

Puro is clean—it does not rust or corrode.

Puro is economical. It allows just the proper amount of cool, clean, fresh water to come through the bubbler. No spurling, no overflowing, no loss. Puro regulates itself. You can attach it in five minutes.

Tell us how many men in your factory and your water pressure in pounds—

We'll tell you just what it will cost to "PUROFY" YOUR WATER SUPPLY.

PURO SANITARY
DRINKING
FOUNTAIN

TRADE MARK

147 University Ave. TORONTO, ONT.

THE IRON WORKS

Successors to LIMITED

Owen Sound Iron Works

Owen Sound, Ont.

Engineers

Boiler-makers

Founders

Machinists

Tank Work
Smoke Stacks,
Grey Iron and
Brass Castings.

Special
Machinery

Made to
Order

MORTON MANUFACTURING CO.
 PORTABLE PLANERS
 DRAW CUT SHAPERS
 SPECIAL DRAW CUT R R SHAPERS
 FINISHED MACHINE KEYS
 STATIONARY & PORTABLE KEY WAY CUTTERS
 SPECIAL LOCOMOTIVE CYLINDER PLANERS
 OFFICE AND WORKS: MUSKEGON HEIGHTS U.S.A.

INDUSTRIAL CARS, FLOOR-
 TRUCKS, PORTABLE STEEL
 TRACK, TURNTABLES.

Hamant Car & Engineering Works
 Hamilton, Canada

"Barnes-Made"
 SPRINGS

are unusual in
 service and wear

They are the result of
 sixty years' experi-
 ence, unsurpassed
 equipment and highly skilled work-
 manship.

A trial will convince you that
 "Barnes-Made" Springs are the
 best buy.

Established 1857.

THE WALLACE BARNES COMPANY
 218 South St., Bristol, Ct., U.S.A.

Mfrs of "Barnes-made" Products
 Springs, Screw Machine Products, Cold Rolled Steel and Wire

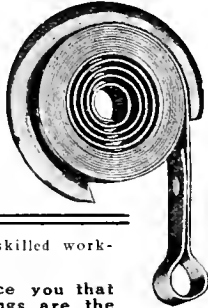

**METAL
 STAMPINGS**

We are manufactur-
 ers of stamped parts
 for other manufactur-
 ers.

We do any kind of
 sheet metal stamping
 that you require. Our
 improved presses and
 plating plant enable
 us to produce the
 finest quality of work
 in a surprisingly
 short time.

We can finish steel
 stamping in Nickel,
 Brass or Copper.

Send us a sample
 order.

W. H. BANFIELD & SONS

372 Pape Avenue, Toronto, Can.

a noticeable decrease, while in 1915 it composed only 2.4 per cent. The total value of 1915 production is given as \$9,902,202.

New Copper District.—During the past twelve months development work has been carried out on a new copper discovery at Newport, County of Gaspe, P.Q. Some very rich ore has been taken out on wide veins assaying as high as 57 per cent. copper content in massive ore from 14 veins already uncovered. Over a large area assays run in payable ore. American interests are contemplating larger development on the recommendation of expert geologists, who have made exhaustive examination of the properties.

Toronto, Ont.—Thorough-going endorsement of the Hydro-Electric extension was given on Monday by the municipalities voting on the question of municipal development of the Chippewa Creek-Niagara Falls power. The question was submitted in practically every municipality having a contract with the Hydro-Electric Commission, and with one exception—Goderich—the cities and towns of the Niagara system voted overwhelmingly for the principle of municipal development of power. In some places opposition was practically non-existent, less than half a dozen votes being polled against the proposal in several places.

Trawler Inquiries—The Submarine Boat Corporation of New York, which was incorporated in August, 1915, to take over the business and stock of the Electric Boat Co., has had agents in Canada endeavoring to place orders for the construction of the 200 trawlers for which it has contracts with the Admiralty. Several Montreal firms have been approached. It is thought unlikely that Canadian firms will be able to take any considerable portion of the business, since they had already refused the whole of the original order before it was offered in the States. The contract calls for 200 trawlers, each 100 feet long, equipped with 500 h.p. Diesel engines, and costing \$150,000.

Toronto Exhibition—The financial report of the Canadian National Exhibition for 1916 was presented to City Treasurer Bradshaw on Saturday last by president Noel Marshall, manager Dr. Orr and treasurer Brentnall. It revealed that the profits of last year's fair were approximately \$77,000, and that the attendance reached 910,000. These figures have only been exceeded once before in the record year of 1913. The distribution of the surplus will be as follows: \$34,613.19 to the city, \$8,044.99 towards the cost of the new eastern entrance, \$25,000 for the construction of new lavatories as approved by the City Council and \$10,000 reserved for working expenses.

U.S. and the "Deutschland"—The absolute secrecy with which the merchant submarine Deutschland, and, later, the fighting submarine U-53, made their way into the Chesapeake and Narragansett

Bays, should serve as a note of warning to the United States, says the *Scientific American*. Whether or not the German Government sent this fighting submarine across for the express purpose of showing the United States that she was capable, if she wished, of running amuck among her shipping, the instant it ventured beyond the three-mile limit, is a matter for conjecture. "This much is certain," says our contemporary, "that after these visits it will be our own fault, and not Germany's, if we fail to realize that what she did to merchant shipping off our coasts, she could just as easily do to the naval and merchant shipping within our own dockyards and harbors."

U.S. Tin-Plate Manufacture—Official returns show the extent to which American manufacturers of tin-plates have secured a footing in foreign markets since the outbreak of war. In the fiscal year ended June 30, 1916, the exports from the United States amounted to 230,472 tons, as compared with 80,009 tons in the year 1914-5, and 47,276 tons in 1913-14. Some indication of the breadth of the area of distribution of the export trade is obtainable from the following figures showing the destinations and volume of the shipments in the fiscal year ended June 30, 1916, the corresponding figures from the year 1913-14 being in parenthesis: Great Britain, 29,783 tons (nil); Canada, 52,394 tons (3,310 tons); Argentine, 18,717 tons (1,282 tons); Brazil, 11,848 tons (805 tons); China, 15,807 tons (4,012 tons); British-Indian, 20,334 tons (9 tons); Japan, 24,647 tons (191 tons); other countries, 33,250 tons (3,685 tons).

Accidents in Metallurgical Plants—Fatal accidents reported at metallurgical plants in the United States in 1915 were 68, of which 30 were in ore-dressing plants and 38 in smelters. In 1914 these were 23 and 33 respectively. These data are from the second report of the Bureau of Mines on accidents at metallurgical works, and cover returns from 110 smelting plants in 1915 as compared with 94 in 1914, and include copper, lead, zinc and quicksilver smelters, as well as refineries, but do not include iron-blast furnaces. They represent also concentrating plants for copper lead and zinc ores, stamp mills, cyanide plants and iron-ore washers. Non-fatal injuries at ore-dressing plants in 1915 were 2,095 and at smelters 5,718; these were 1,434 and 5,673 respectively in 1914. There were 63 permanent partial disabilities at ore-dressing plants and 87 at smelters. Total men employed were 49,891 in 1915, as compared with 41,461 in 1914.

WOODWORKING

North Vancouver, B.C.—The Canadian Robert Dollar Co. will build a saw mill and wharf here.

Warton, Ont.—Fire on December 24 completely destroyed the local branch factory of the Canada Furniture Manufacturers, Ltd., the main factories of which are at Woodstock. The loss is estimated at \$75,000, which is partly covered by insurance.

PERSONAL

W. G. Ross, chairman of the Montreal Harbor Commissioners, has been appointed director of naval recruiting in the Province of Quebec.

Frederick J. Brule has resigned from the staff of the Anaconda Copper Co., to accept the position of chief engineer of the British American Nickel Corporation with headquarters in Toronto.

W. D. Ackworth, the financial expert of the commission inquiring into the Canadian railway situation, has arrived in Ottawa. Mr. Ackworth will assist A. H. Smith, chairman, and Sir Henry Drayton, in preparing a report.

Capt. John Trethewey, for many years recognized as one of the leading mining men in Canada, died after a long illness, in Toronto, on December 25. Captain Trethewey, who was in his 77th year, came to Toronto to reside when he retired from business ten years ago. Before that date he had lived for 20 years in Owen Sound.

John I. Reid has been made superintendent of the Longue Pointe plant of the Canadian Steel Foundries, Ltd., Montreal. He assumes his duties at once. He was formerly works manager of the American Steel Foundries' plant at Chester, Pa., and recently sales agent for the company at 30 Church Street, New York City.

Col. Thomas Cantley, president and general manager of the Nova Scotia Steel & Coal Co., has returned from a trip to England and France. He was away about seven weeks, a considerable part of the time being spent in France, his company having large contracts with the French Government.

Sub-Lieut. Andrew Dyas MacLean has been granted a commission in the Royal Naval Volunteer Service, and is at the present time taking a course at Greenwich. He is a son of Major Hugh C. MacLean, of the Hugh C. MacLean Publishing Co., Toronto and Winnipeg. The young officer went to England to join the motor-boat patrol service.

RAILWAYS AND BRIDGES

Edmonton, Alta.—**J. D. McArthur**, president of the Edmonton, Dunvegan, and British Columbia and allied railways, has stated that tenders had been invited for the big steel bridge across the Peace River, immediately north of the town of Peace River. It will cost a million dollars, and is to be ready in eighteen months.

MARINE

Montreal, Que.—Canadian Vickers, Ltd., are enlarging their shipbuilding plant at Maisonneuve, by adding a berth 500 x 128 feet and another 400 x 100 feet. This will provide for the construction of vessels of 12,000 tons.



Steel Shell Forgings or Billets of any size or weight will move any distance or about curves upon our specially constructed Gravity Carriers and Incline or Horizontal power devices. No labor required.

Canadian Mathews Gravity Carrier Co., Toronto, Ont.

We are qualified Tool, Die, Jig, Gauge and Fixture Makers.
 WRITE US.
Windsor Machine & Tool Works.
 WINDSOR, ONT.



OVENS

Enameling and Varnishing.
 OVENS Heated by
 GAS, ELECTRICITY, STEAM or COAL
 Write for New Pamphlet Just Issued
Brantford Oven & Rack Co., Ltd., Brantford, Canada

STEEL CASTINGS

We are in a position to make immediate delivery of all kinds of steel castings, 100 lbs. and heavier.

Send us your next order.

Dominion Steel Foundry Co., Ltd.

Hamilton, Ont.

PATENT ATTORNEYS

BABCOCK & SONS

ESTAB. 1877

PATENTS-TRADE MARK-DESIGNS IN ALL COUNTRIES

Book "Patent Protection"—free. Master of Patent Laws, Formerly Patent Office Examiner.

99 St. James St., - Montreal, Que.
Branches: Ottawa, Washington.

RESEARCH BUREAU

REPORTS BY EXPERTS ON SCIENTIFIC, TECHNICAL AND INDUSTRIAL DEVELOPMENT.

SPECIAL RESEARCHES ARRANGED.

PATENTS, TRADE MARKS, ETC.

HANBURY A. BUDDEN CABLE ADDRESS
712 DRUMMOND BLDG., MONTREAL "BREVET"

PATENTS

Fetherstonhaugh & Co.
Patent Solicitors. Head Office,
Royal Bank Bldg., Toronto,
Ottawa Office, 5 Elgin St.
Send for our Plain Practical
Pointers. Copy of National
Progress, in which our patents
are advertised, mailed free.

PATENTS TRADEMARKS AND DESIGNS

PROCURED IN ALL COUNTRIES

Special Attention given to Patent Litigation

Pamphlet sent free on application.

RIDOUT & MAYBEE 59 Yonge Street
TORONTO, CANADA

Mackinnon, Holmes & Company, Limited

Design, manufacture and
erect all classes of Steel
Work.

Specialties :-

Bridges
Oil and Water Tanks
Penstocks
Coal and Coke Bins
Smoke Flues & Stacks.

Prompt deliveries assured.

Designs and Estimates from Head
Office at

SHERBROOKE, QUE.

TENDERS

Winnipeg, Man.—Tenders will be called until Feb. 12, 1917, for works required for the completion of the new Parliament Buildings which include the following. Heating and ventilating, electric conduit and wiring. Thos. H. Johnson, Minister of Public Works, Winnipeg.

Toronto, Ont.—Tenders will be received, addressed to the chairman, Board of Control, City Hall, Toronto, up to January 16, for the installation of a 40 million Imperial gallon centrifugal sewage pump at the main sewage pumping station, Toronto. Specifications and forms of tender may be obtained at the Works Department, Room 6, City Hall.

Ottawa, Ont.—Tenders will be received up to January 15, for the construction of a reinforced concrete lighthouse tower and fog alarm building combined, and a wooden dwelling at Point Abino, township of Bertie, Welland County, in the Province of Ontario. Plans, specifications, form of contract and schedule of wages, can be seen, and forms of tender procured, at the Department of Marine, Ottawa; at the Harbor Master's office, Toronto, and at the post offices, Welland, Port Colborne, St. Catharines, Bridgeburg, Hamilton and Brantford.

CONTRACTS

Vancouver, B.C.—The general contract for the construction of an extension to the C.P.R. Co's, Pier "D," has been let to S. E. Junkins and Co., Vancouver.

Toronto, Ont.—The Board of Education have awarded the following contracts in connection with additions to the Orde Street School. Metal roofing, D. M. Rowe & Co., \$1,327; ornamental iron work, Canadian Ornamental Iron Co., \$3,400; plumbing, Fred Armstrong Co., \$6,095; heating and ventilation, Fred Armstrong Co., \$6,890; heat regulators, Johnson Temperature Regulating Co., \$826; electric wiring, Fred Armstrong Co., \$640.

INCORPORATIONS

Dominion Iron & Wrecking Co. has been incorporated at Ottawa, with a capital of \$50,000, to buy and sell steel, iron and scrap metals of all kinds, and to carry on the business of a wrecking company, with head office at Montreal.

The Canada Glass Works, Ltd., has been incorporated at Ottawa, with a capital of \$250,000, to manufacture bottles, carboys, flasks, etc. The head office is at Toronto, and the incorporators are: H. P. Hill, A. C. Hill and S. F. MacDougall, all of Ottawa.

The Pembroke Machining Co. has been incorporated at Toronto, with a capital of \$100,000, to establish and operate a machine shop and foundry at Pembroke,

Ont. The provisional directors are: E. A. Dunlop, James F. Munro and Charles A. Eaton, all of Pembroke.

British Cordite Co. has been incorporated at Ottawa with a capital of \$50,000, to manufacture cordite and explosives of all kinds, with head office at Montreal. The incorporators are: Walter R. L. Shanks, Francis G. Bush and George R. Drennan, all of Montreal.

International Magnesite, Ltd., has been incorporated at Ottawa, with a capital of \$250,000, to manufacture magnesite, graphite, and other minerals. The head office is at Montreal, and the incorporators are: Leon Daoust, Aime Daoust, and Ernest D. White, all of Montreal.

The St. Louis Auto Machinery Co. has been incorporated at Ottawa, with a capital of \$40,000, to manufacture automobiles, bicycles, and engines, etc., at Windsor, Ont. The incorporators are: Joseph B. St. Louis, Joseph F. Knight and Henry C. Cage, all of Windsor, Ont.

Port Arthur Copper Co. has been incorporated at Toronto, with a capital of \$2,500,000, to acquire and develop mineral deposits, with head office at Toronto. The incorporators are: Arthur E. Way, William D. McKay and James H. Young, all of Toronto.

R. W. Stewart & Co. has been incorporated at Toronto, with a capital of \$40,000, to manufacture paper specialties and boxes, etc., at Windsor, Ont. The provisional directors are: Robert W. Stewart and Richard Bingham, of Windsor; also Albert M. Draper, of Detroit, Mich.

The Northern Bolt, Screw & Wire Co. has been incorporated at Ottawa, with a capital of \$500,000, to manufacture nails, bolts, nuts, screws, rivets, tacks, taps and dies at Owen Sound, Ont. The incorporators are: John McEwen, Clarence L. Vanwyck and James H. Van Overbeek, all of Owen Sound.

Capital Machinists & Founders, Ltd., has been incorporated at Ottawa, with a capital of \$50,000, to carry on the business of machinists, engineers, brass and iron founders, etc. The head office is at Ottawa, and the incorporators are: Michael J. Skelly, Walter L. Goode, and E. P. McGill, all of Ottawa.

Metal Foundries of Canada, Ltd., has been incorporated at Ottawa, with a capital of \$50,000, to develop mineral deposits and to carry on the business of smelting, refining, milling and foundry company. Head office is at Toronto, and the incorporators are: John M. Duff and James G. Hamilton, of Toronto.

The Wagner, Chambers, Glasco Co. has been incorporated at Ottawa, with a capital of \$49,900, to carry on a general machine shop business and to manufacture munitions of all kinds. The head office is at Toronto, and the incorporators are: William E. Wagner, James L. Chambers, of Toronto, and Ernest S. Glasco, of Oakville, Ont.

TO SHELL MAKERS

We Specialize on:

- (a) Our Patented Nosing Die (4.5"-5" and 6").
- (b) Thread and Seating Gauges (all sizes).
- (c) Milling Hobs for Milling Nose of all sizes of shells.
- (d) Thread and Seating Attachment for Lathes. (Patent Applied for).
- (e) Band Turning Tools for 4.5" and 6" shells, Price \$25.

- (a) If you are changing Nosing Dies every five or ten thousand shells, you are wasting valuable time and money. Try our patented die, and so make your nosing operation continuous.
- (b) We guarantee that if our Thread and Seating Gauge passes your shells, that the Government Gauges will also pass them; otherwise we take them back without hesitation. The life of our Gauge is longer than all others. Price \$50.
- (c) Our Milling Hobs are made by experts, and we specialize on this class of work for all sizes of shells. Price \$15.
- (d) Which would you rather use?

1 Thread Milling Machine
and
4 Hand Seating Tools
requiring
5 men for each Shift
turning out
150 Shells per Shift at a cost of \$18.00

|
OR
|

1-16" Lathe
and
1 Thread and Seating Attachment (Patent Applied For)
requiring
1 man for each Shift
turning out
150 Shells per Shift at a cost of \$4.00

The cost of this attachment is only \$120.00, and your engine lathe will be of use after the war work is over.

Toronto Type Foundry Company, Limited
50 Coleman Avenue, Toronto

Montreal Machinery & Supplies, Limited

407 McGill Bldg., MONTREAL, QUE. 211 McGill Street

CONSULT US FOR REQUIREMENTS OF

Machinery, Machine Tools, Factory and Mill Supplies

We make a specialty of designing and equipping complete munition plants. Our facilities in this connection will make our service of value to you.

WATCH OUR ADVERTISEMENT FOR FURTHER ANNOUNCEMENTS.

Increased Production Means Increased Profits

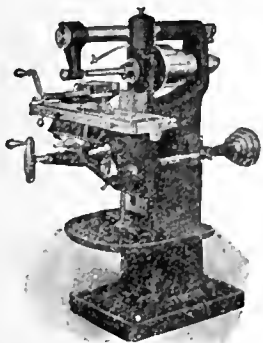

Large Millers
for large work
— STEPTOE
MILLERS
for small work.

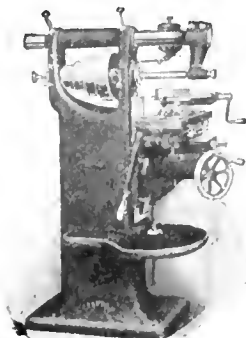

Large Planers
for large work
— STEPTOE
SHAPERS
for small work.

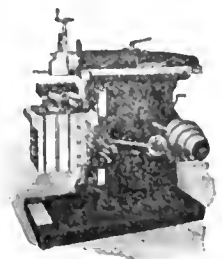

Will result in increased production; less money invested in machinery, and increased profit.

THE JOHN STEPTOE COMPANY
CUMMINSVILLE, CINCINNATI, OHIO, U.S.A.

If any advertisement interests you, tear it out now and place with letters to be answered.

Classified Advertising Section

Rates (payable in advance): Two cents per word first insertion; one cent per word subsequent insertions. Count five words when box number is required. Each figure counts as one word. Minimum order \$1.00. Display rates on application.

FOR SALE

GAP LATHIE, 28 x 42 x 16 FT. BED, FOR sale, cheap. Guarantee Motor Co., Hamilton, Canada. (4)

ENGINE FOR SALE—50 HORSE-POWER Corliss; no reasonable offer refused if taken at once. Box 387, Chatham, Ont. (2)

BROWN-BOGGS MARKING MACHINE FOR 4.5 shells. Has been used for short time only, and is in good condition. Box 248, Canadian Machinery. (24)

FOR SALE—1 1/4-1 1/2 MODEL A CLEVELAND automatic screw machine. F. T. Coffin, 17 Tudor St., Cambridge, Mass., U.S.A. (21)

FOR SALE—75 H.P. CANADIAN GENERAL Electric motor, 25 cycle, 3 phase, 550 volts, 950 R.P.M., in first-class condition. Box 258, Canadian Machinery. (26)

1 VERTICAL, SINGLE ACTION, DOUBLE cylinder hydraulic pump, 6" stroke, all ready to connect up; almost new; price \$75. McGregor & McIntyre, 1139 Shaw Street, Toronto. (1f)

FOR SALE—FIFTEEN HEAVY CAST IRON columns, from thirteen to seventeen feet long. Columns tapered and have good heavy base and top. Also four roof trusses. Sixty feet long. Ten feet in centre, eight foot at ends. Will cut columns to suit purchaser. Woodside Bros., Port Arthur, Ont. (2)

1—2-SPINDLE SHAPER, WOOD TOP, JOHN Ballantyne, Preston, make, used two months. 1 Dynamo, 45 lights, Toronto and Hamilton Electric Co. make. Used five months. Good as new. Box 195, Jordan, Ont. (R.T.F.)

FOR SALE—1 40 H.P. ROBB, ARMSTRONG high-speed engine; 1 4 x 1 Marsh deep well steam pump, and 1 Barton generator, 80 lamp capacity, with switch-board. All in good order and cheap for quick sale. Richards-Wilcox Canadian Co., Ltd., London. (20)

FOR SALE—TWELVE H.P. GAS OR GASOLINE Engine. Gould, Shapley & Muir Ideal. In first-class condition. Cheap. Stedman Brothers, Ltd., Brantford, Ont. (21)

DOUBLE-END FEATHERSTONE ANGLE cutting off machine with countershaft and equipment adapted for cutting off two 4.5 forgings at once. Bargain \$500. Medicine Hat Pump & Brass Mfg. Co., Ltd., Medicine Hat, Alberta. (1f)

BAND SAW—COWAN & CO. MAKE, 30" Iron Frame. Post Machine 29 1/2" x 33". Iron Tipping Table and Saw Guard, including Brazing Tools, setter for Filing, etc., has had very little use. Whaley, Royce & Co., Limited, 227 Yonge St., Toronto, Ont. (23)

SHRAPNEL SOCKET AND ADAPTER machinery, turret lathes, boring machines, cutting-off machines and thread millers tooled for operation. Globe Electric Machine Co., Hamilton. (1f)

FOR SALE, CHEAP—ONE TWENTY-TWO inch by ten-foot bed Porter lathe; compound rest, steady rest, set change gears, large and small face plate, eighteen-inch four-jaw chuck, boring bar, four tool holders and taper socket fitted. New Prague Flouring Mill Co., New Prague, Minn., U.S.A.

2—30 H.P. PRACTICALLY NEW, LATEST type Canadian General Electric Company's 20 H.P., 60 cycle, 550 volt, 3 phase, 900 R.P.M. Induction Motors, with starting compensators and adjustable sliding base, pulley 14", diameter 8" face. Price, \$500 each f.o.b. Sarnia, Ont. 1—20 H.P. Same as above, pulley 11" diameter, 10" face. Price, \$390 f.o.b. Sarnia, Ont.

WANTED

WANTED—COMPLETE SET OF DRAWINGS or blue prints of Universal grinder, with all attachments. Box 251, Canadian Machinery. (1)

ONE AUTOMATIC SCREW MACHINE, capacity up to 1-in.; can use machine having had some service. Canadian Matthew-Gravity Carrier Co., 484 Richmond St. west, Toronto. (2)

WANTED—POWER-DRIVEN ROLLER 8' long, suitable to roll 1/4" steel plates; state make, condition, time used. Give price and particulars to L'Air Liquide Society, corner First Ave. and Ernest St., Maisonneuve, Montreal.

WANTED—SMALL SCREW-CUTTING ENGINE lathe 12" or 13" x 5' or 6' bed, automatic feed, power cross feed, compound rest; must be cheap and lathe in good working order; give full particulars in first letter. J. W. M., Suite 34, Thelmo Mansions, Burnett St., Winnipeg, Man. (24)

WANTED—THE FOLLOWING EQUIPMENT for 18-pr. H.E. shells:—2 electric or steam baking ovens, 2 painting machines, 1 banding press and pump, 2 band turning machines, 3 sensitive drills for drilling and tapping grub screw hole, 1 Bowers varnish pump, 1 marking machine. Send quotations to Box 253, Canadian Machinery. (24)

REPAIRING

ALL KINDS OF MACHINERY REPAIRED, rebuilt and installed. W. H. Sumbling Machinery Co., 643 Yonge Street, Toronto, Ont.

SITUATIONS WANTED

TOOL MAKER, ACCURATE, GOOD draughtsman, desires responsible position. Box 254, Canadian Machinery. (4)

SUPERINTENDENT, DESIROUS OF change, 18 pdr. shrapnel, and 6" H. E. shells. Box 247, Canadian Machinery. (26)

MECHANICAL ENGINEER, EXPERIENCED in eighteen-pounders and six-inch

Shipment from Stock

2—No. 2 "Kemp Smith" Full Universal Milling Machines.

4—"Lees Bradner" Thread Millers (Used, but in good condition), arranged for milling 2" 14 thread in Nose of 18-pdr. H.E. Shells. Price, \$1,150.00.

or

4—"Lees Bradner" Thread Millers arranged for milling 2" 14 thread in Nose of 4.5 Mark VII H.E. Shells. Price, \$1,375.00.

Williams & Wilson Limited

320 St. James St., Montreal, P.O.

nosed-in shells, with twelve years' drawing office, shop and general experience, will be disengaged shortly. Box 252, Canadian Machinery. (25)

EXPERT FOUNDRYMAN FAMILIAR with all modern foundry appliances, desires position as foreman or assistant in gray or malleable iron foundry. Box 250, Canadian Machinery. (25)

SUPERINTENDENT WITH PROVEN MECHANICAL and executive ability desires position as same, or one of equal grade. Wide experience with well known firms manufacturing high explosive shells, rifles, electrical machinery and instruments, light and heavy sheet metal and plate products. Have satisfactorily supervised installation and organized new plants for widely varied lines of product. Address P.O. Box 122, Dartmouth, Nova Scotia. (25)

SITUATIONS VACANT

TOOLMAKERS AND MECHANICS. APPLY Pease Foundry Co., Brampton; Junction 431f. (3)

WANTED—MAN TO TAKE CHARGE OF machine shop doing repair and new work. Must be up-to-date and able to show results. State experience and salary and when you can start. Apply Box No. 257, Canadian Machinery. (26)

FIRST CLASS GRIDLEY AUTOMATIC men wanted to set up Gridley automatic machines, also operators for same, highest wages paid, only first class mechanics need apply. Apply 47 Richmond St. East, Toronto. (24)

WANTED—NIGHT SUPERINTENDING TO take charge of factory making 4.5 sockets. Apply Box 237, Canadian Machinery.

ALL-ROUND MACHINIST WANTED FOR tool-room; highest wages paid. A. R. Ormsby Co., Limited, 48 Abell Street, Toronto. (21)

WANTED—FIRST-CLASS MACHINIST able to take charge of our repair shop. Apply Hull Iron & Steel Foundries, Ltd., Hull, Que. (23)

MECHANICAL DRAUGHTSMAN WANTED for tracing and detailing on general machine work, also opening for man with experience on plate and structural work. Box 245 Canadian Machinery. (23)

SPLENDID OPPORTUNITY FOR YOUNG man about twenty-one, well educated and with some mechanical knowledge, who desires to learn the machinery business. Apply in first instance with full particulars as to experience, etc., to Box 243 Canadian Machinery.

WANTED—EXPERIENCED MILL WRIGHT and Machinist to take charge of construction and repair work in growing factory. A man who has had experience as foreman preferred. An excellent opportunity for a first-class man. State when you can start, also experience and salary wanted. Apply Box No. 256, Canadian Machinery. (26)

WANTED—EXPERIENCED MECHANICAL Draftsman; one who has had some experience on machine design and factory layout preferred. Apply stating experience and salary desired to the Goodyear Tire & Rubber Co., Bowmanville, Ont. (26)

WANTED—TECHNICAL ENGINEER—steady, energetic, practical, to learn the business and take charge of the operating and construction departments of a firm manufacturing compressed gases, and apparatus to use such gases. Reply giving experience and salary expected to Box No. 255, Canadian Machinery, 701 E.T. Bank Bldg., Montreal. (26)

CANADIAN MACHINERY

AND MANUFACTURING NEWS

A weekly newspaper devoted to the machinery and manufacturing interests.

Vol. XVII.

TORONTO, JANUARY 11, 1917

No. 2

EDITORIAL CONTENTS

Machining the 4.5 in., Mark VII. Howitzer Shell	21-24
General	24
Dominion Steel Corporation Year.	
Editorial Correspondence	25
Removing the Monotony of Repetition Work....Nicking Attachment for Shell NosesOver-Much Drilling Efficiency....Belgian Ball-Test Machine....Human Factor in the Workshop.	
General	
Thread Indicators Canada's 1916 Coal Output Concerning Supplies from United Kingdom.	
Spokes in Industry's Wheel	29
John Sharp.	
Progress in New Equipment	30-31
Motor-Driven Tapping Machine....Single Purpose High Speed Drilling Machine.... Press for Stamping Washers from Scrap Plates.	
General	31
Canada's Iron Output.	
Editorial	32
More Effort, More Men, More Money....The Paper Situation.	
Industrial Notabilities	33
Meurig Lloyd Davies.	
Selected Market Quotations	34-35
The General Market Conditions and Tendencies	35-37
Montreal Letter....Toronto Letter... Big Contract Abandoned Manufacturing Patriotism....Enlarged Trade Intelligence Service....Canadian Commercial Intelli- gence Service.	
Industrial and Construction News	38

THE MACLEAN PUBLISHING COMPANY, LIMITED

JOHN BAYNE MACLEAN, Pres. H. T. HUNTER, Vice-pres. H. V. TYRRELL, Gen. Man.

Publishers of Hardware and Metal, The Financial Post, MacLean's Magazine, Farmer's Magazine, Canadian Grocer, Dry Goods Review, Men's Wear Review, Printer and Publisher, Bookseller and Stationer, Canadian Machinery and Manufacturing News, The Power House, The Sanitary Engineer, Canadian Foundryman, Marine Engineering of Canada.

Cable Address: Macpubco, Toronto; Atabek, London, Eng.

CANADIAN MACHINERY AND MANUFACTURING NEWS

PETER BAIN, M.E., Editor. B. G. NEWTON, Manager.

Associate Editors: A. G. WEBSTER, J. M. WILSON, J. H. RODGERS.

CHIEF OFFICES:

CANADA—Montreal, 701-702 Eastern Townships Building, Telephone Main 1001, Toronto, 113-113 University Ave., Telephone Main 7321, Winnipeg, 22 Royal Bank Building, Telephone Garry 2313.

GREAT BRITAIN—LONDON, The MacLean Company of Great Britain, Limited, 88 Fleet Street, E.C., E. J. Dodd, Director, Telephone Central 129600, Cable Address: Atabek, London, England.

UNITED STATES—New York, R. B. Huesitts, 115 Broadway, N.Y., Telephone Rector 8971; Boston, C. L. Morton, Room, 733, Old South Building, Telephone Main 1021. A. H. Byrne, 1101 5-6-7 Fort Dearborn Bldg., 105 W. Monroe St., Chicago, Telephone Radolph 3234.

SUBSCRIPTION PRICE—Canada, Great Britain, South Africa and the West Indies, \$3.00 a year; United States, \$2.50 a year; other countries, \$4.00 a year; Single Copies, 15 cents. Invariably in advance.

Machining the 4.5 in. Mark VII. Howitzer Shell

By A. F. Menzies *



Some better idea will perhaps be had of the scope of munitions manufacture within our borders when note is made of the fact that the accompanying article refers to the activities of a plant situated well-nigh to the extreme Western limit of this far-flung Dominion. Whether East be East, and West be West, in some realms of reasoning or its twin brother class imagination, it goes without saying that as far as meeting the insistent need of the hour is concerned, the aim and effort are as one, a condition likely to be permanent in its effect.

THE shop from which the following data were taken, relative to the machining of British 4.5 in. M. VII. H. E. shells, had been engaged for some time on an 18 pdr. H.E. contract, but, in common with other shops on the Pacific Coast changed over to the production of the larger size shells immediately the others were completed. The equipment used is all of standard type, except the cutting-off machine and bull-dozer, these together with all small tools and attachments, turrets, etc., having been designed and built on the premises. The shells are finished up to the riveting-in of the base-plates; banding, varnishing, etc., being done at a central plant which handles the output of a number of shops in the district. The capacity of the shop was estimated at 200 shells per day; at the time of writing, however, this output had not quite been reached. As every one engaged on munition work knows, it takes a little time to get machines and operators into line, and until everything is running smoothly, the maximum output cannot be expected.

The forgings, as received, are well enough known to omit description here. The first operation consists of the selection of forgings which are sufficiently

concentric to be centered true with the hole. This is determined by the use of a wall caliper having two marks on the stem. Forgings which show no portion of the wall to be less than $\frac{3}{4}$ in. in thickness are passed along. Those which show occasional variation from $\frac{5}{8}$ in. to $\frac{3}{4}$ in. are piled separately and sent through in batches, care being taken at the centering drill that the center is shifted sufficiently to allow the forging to clean up both outside and inside. Forgings which show a wall thickness of less than $\frac{5}{8}$ ins. cannot be used. In justice to the inspectors at the forging

iron casting carrying a hollow cast iron spindle running in babbitted bearings. The shell is slipped onto the spindle and secured by means of a set screw. To care for varying sizes of forgings, four set screws are located at 120 degs. from the locking screw; by properly adjusting these screws, the shells can be made to run absolutely true. As forgings of each heat number, and often of several heat numbers, are of practically the same size, adjustment is not often required. The head of the cutting-off machine is carried on a pair of I beams, which also carry the compound slide rest. The tool used is a piece of 3-16 in. x 2 in. high speed steel held in a special holder.

The location of the cut is found by a hook gauge which is so placed as to touch the bottom of the rough hole, the short leg forming a stop against which the parting tool is brought. A depth gauge is used to check the operator's work. The centering was done on a Rockford Lathe & Drill Press Company's machine. The post over which the shell is placed has a hollow cone held up by a spring

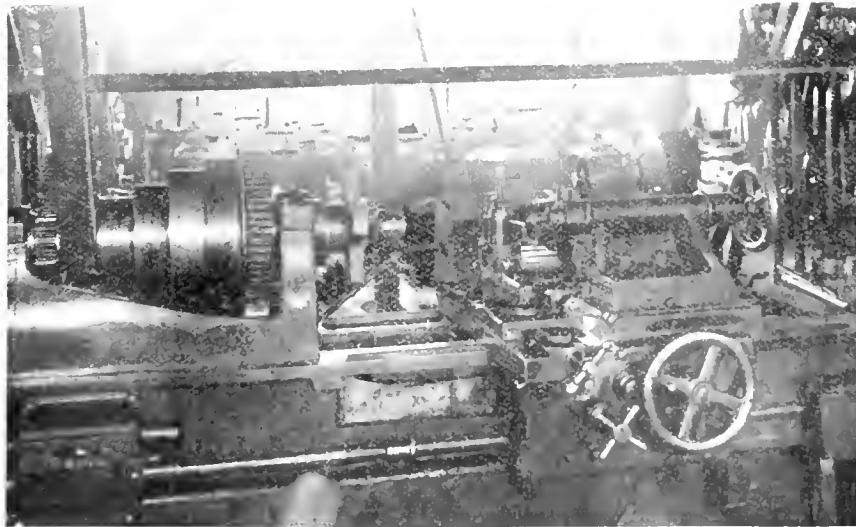

FIG. 1. LATHE IN WHICH SHELL BODIES ARE ROUGH TURNED

shop, it should be stated that this class are rarely in evidence.

Open End Cutting Off

The open end of the shell is trimmed in a cutting-off machine built for the purpose. The head consisted of a heavy

to centre the open end, while the base is brought true by a hardened cap on the upper end of the post. The post is carried on a swing table having a locating pin which enters a hole in the fixed table.

*Mechanical Engineer, New Westminster, B.C.

Rough Turning.

A 24-in. MacGregor-Gomrley lathe is used for the rough turning operation. This machine does its work in one cut, using two tools at a feed of 1-20 in. per revolution. Occasionally, with a shell that is much out of true or very hard, the feed has to be reduced. The back

give the operator the correct depth of hole. A depth gauge is used to check the operation. On both drill presses the shells are held in hinged vises.

Inside Finish

The inside finish, perhaps the most important operation on all H.E. shells, is done next. Two machines fitted with

hand feeding is used to get a good smooth finish. The boring bars are of tool steel, fluted for the egress of chips. A $\frac{1}{4}$ in. brass pipe soldered into one flute carries the cutting compound to the business end. The second bar, in addition to its work on the hole faces off the end of the shell and forms the bevel. The tools for this work are held in a collar on the bar. The chucks used on this and on all subsequent chucking operations are of the collet type, having a cast iron body with forged steel jaws. The closing nuts which have the hand-wheels cast with them were to have been cast steel, but, by a mistake in the foundry, cast iron was substituted. So far, they give every evidence of standing up to their work. The chucks themselves have given every satisfaction, the hand wheels making them very convenient. The lathes used for the inside finish are both Le Blond products—one being 18 ins. and the other 24 ins. After the inside finish operation, the shells are examined for depth of hole, concentricity and smoothness of bore.

Nosing Operation.

Closing-in the noses constitutes the next operation. The shells are heated in an oil-fired furnace, constructed of steel plates and angles, and lined with Clayburn fire brick. No water jacket is provided and beyond a slight buckling of the front plate, no operation or other troubles have been experienced. The fuel used is crude oil delivered to the burners at from 35 to 40 lbs. pressure per sq. in., and at a temperature of about 225 degs. F. The oil is heated at starting by means of a Hauck kerosene torch directed on a coil of $\frac{1}{4}$ in. pipe through which the oil is passed. After getting under way, a water heater takes

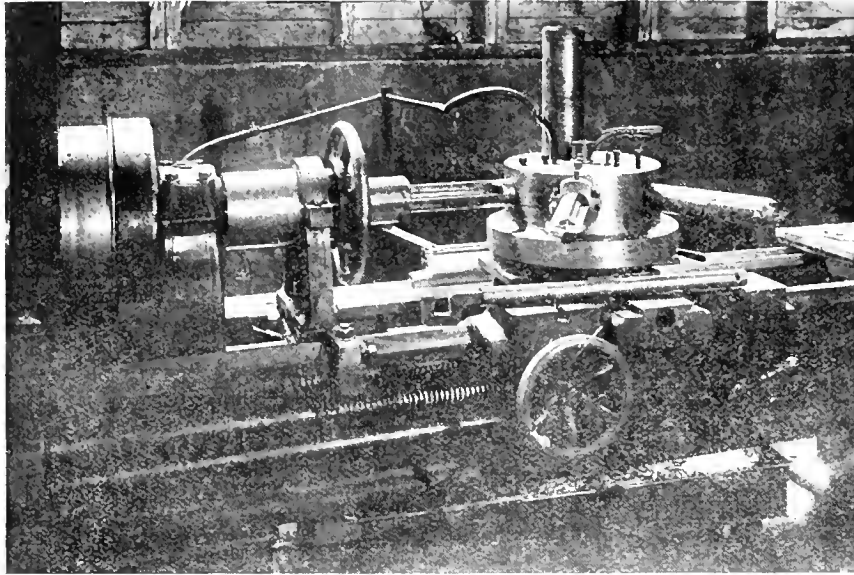

FIG. 2—FINISH MACHINING SHELL INTERIOR

tool which leads and does the heaviest work, is of high speed steel, and is held in a cast iron arm bolted to the saddle. The front tool of $\frac{1}{2}$ in. sq. stellite is gripped in a special holder in the tool post. The rough turned diameter of the shell is 4 9-16 ins., and the gauge used is of the ordinary snap type having limits .015 above and below the nominal size. The driving chuck on the rough-turn lathe is shown in Fig. 1, as are also the different tools. The chuck is of hardened tool steel, and has three cams formed on it. The cams force out hardened rollers to grip the inside of the shell.

The unused part of the long bed of the rough-turn lathe is used on which to mount a spare head and tail stock. These, with the addition of a compound rest built from the same patterns as that on the cutting-off machine, make a convenient apparatus for facing off the bases. This operation brings all the shells to the same over-all length, and, as the amount cut off the open end is gauged from the bottom of the hole, the base thickness is constant. Two drill presses are used to rough out the hole. The first, a 30-in. Bausch machine, uses a bar with a single cutting tool which is fed down to where the hole begins to curve inwards. A spider guide, made to fit over the open end of the shell, forms a support for the bar. The other drill press, a 38-in. Niles machine rough forms the bottom with a forming tool held in a bar. A hardened sleeve made so as to just slip into the hole bored by the first drill press guides the bar. As the power feed cannot be used on some shells, a pointer is fixed to the bar to

very heavy turrets are engaged on this work. The turrets are 16 ins. in diameter where the bars spring from, and have a 20-in. diameter bearing on which to swing. Fig. 2 shows one of the lathes on this operation. The shell on the turret shows the bevel on the outside of the open end. The beveling leaves a diameter of $4\frac{1}{8}$ ins., and is carried back $\frac{3}{8}$ ins. There are three boring bars, the

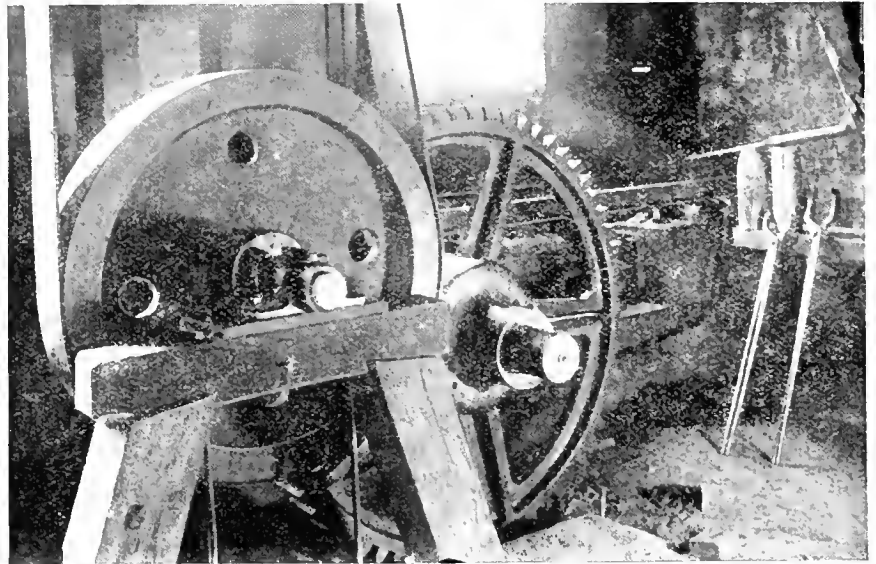

FIG. 3—BULLDOZER IN WHICH THE NOSING OPERATION IS PERFORMED

first carrying point tool to true up the hole. The next, a rough bottoming cutter takes out all but a light shaving. The finishing cutter is run-in on power feed until almost at the bottom, when

up the work. The latter is constructed on the same principle as a kitchen boiler. A reservoir made of 8-in. pipe containing a coil of $\frac{1}{2}$ -in. pipe made up of three lengths welded together, is con-

needed to the city water supply. A loop, starting from the bottom of the reservoir and passing twice across the top of the furnace, entering the reservoir again near the top, forms the heating surface. Air is supplied to the furnace at from 9 to 10 oz. pressure, by a Buffalo Blower & Forge Co. pressure blower. The oil

The shells are next tapped out to size by hand, and the fuse seat trued up with a special cutter. A centred plug is screwed into the fuse hole and the shell held between centres for turning the body and profile. A driver with a slot to take the lug on the plug, is screwed onto the headstock spindle. As

the operator, the shells being examined for size with gauges also for shape of profile and for concentricity. Fig. 4 shows the profile lathe with a shell ready to be put in, the centred plug being clearly indicated, also the gauges used.

Copper Band Recess.

Cutting the upper band recess is the next operation. The lathe, a 16 ins. C. M. C. product to which a special attachment was added, the cross slide being removed, is shown in Fig. 5. The attachment fits the cross-slide ways and carries a roughing tool which operates on the under side of the shell, also two undercutting tools which operate at the back, and a waving tool at the front. The roughing tool operates by drawing the whole attachment toward the front by means of the cross slide screw. As this tool passes the centre and ceases cutting, a stop is encountered which locates the attachment to suit the undercutting tools. One revolution of the hand wheel A, feeds these tools in, and a spring returns them. The attachment is then returned to its first position against a stop located to suit the waving tool, and bringing the roller B in operation against the cam C, causing the wave tool holder to reciprocate. The hand-wheel D, feeds the tool into its work, a stop being provided to get the correct diameter. In this machine, the shell is held in a cup centre at the headstock, being driven by a pin engaging in a slot in the driver E, which is screwed into the fuse hole. To prevent the saddle shifting and altering the location of the band recess it is secured to the ways by a clamp at each side.

Forming Base Recess.

A 16-in. Le Blond lathe, shown in Fig.

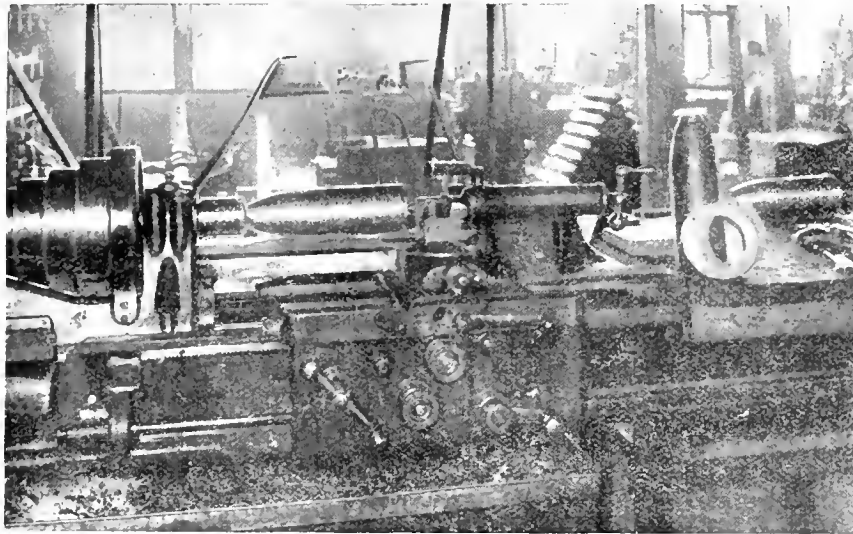

FIG. 4—FORMING SHELL BODY EXTERIOR PROFILE

burning equipment was installed under the supervision of E. C. Hoeh, of the Machinery Installation Co., of Vancouver. The channel iron, on which the shells are seen standing in Fig. 3, runs along the front of the furnace and forms a table on which the shells are rolled to the bulldozer.

The nosing is done on the bulldozer shown in Fig. 3, the crank shaft of the latter being 6 ins. dia., with 7 ins. stroke. The dies used are of cast iron which seem to stand up to the work very well. After being closed-in, the shells are placed nose down in a galvanized iron pan containing about 8 ins. of mica. When cool enough to handle, they are examined to see that there is enough metal inside to clean up, and also for length. To judge whether a shell has sufficient metal inside or not requires not a little experience.

Finishing Inside of Nose.

The next machining operation is that on the inside of the nose. This is done on a 16-in. MacGregor-Gourlay lathe fitted with a chuck and a turret. The nose is first bored out below the fuse hole recess for the thread and neck. At the same time, a tool held in a collar on the reamer bar faces off the nose to the correct bevel. The inside profile is machined with two forming tools, one roughing-out and the other finishing. The tapping is done with a Murehey collapsible tap, after which the recess is put in with a tool mounted on an eccentric. To check the collapsible tap, an old 18 pdr. fuse hole gauge which had been lapped .003 in. small is used. The foregoing operations being found too much for one machine, the reaming, tapping and undercutting were removed to another lathe.

two plugs are provided, the operator always has a shell ready to go into the machine which is an 18 in. American lathe. The tool, $\frac{3}{8}$ in. high speed steel is held in a block holder which can be moved in line with the lathe to bring the profile exactly right. A 2 ins. diameter roller secured to the cross slide, from which the screw had been removed, is held to the forming bar by a spring. The latter is supported by two cast

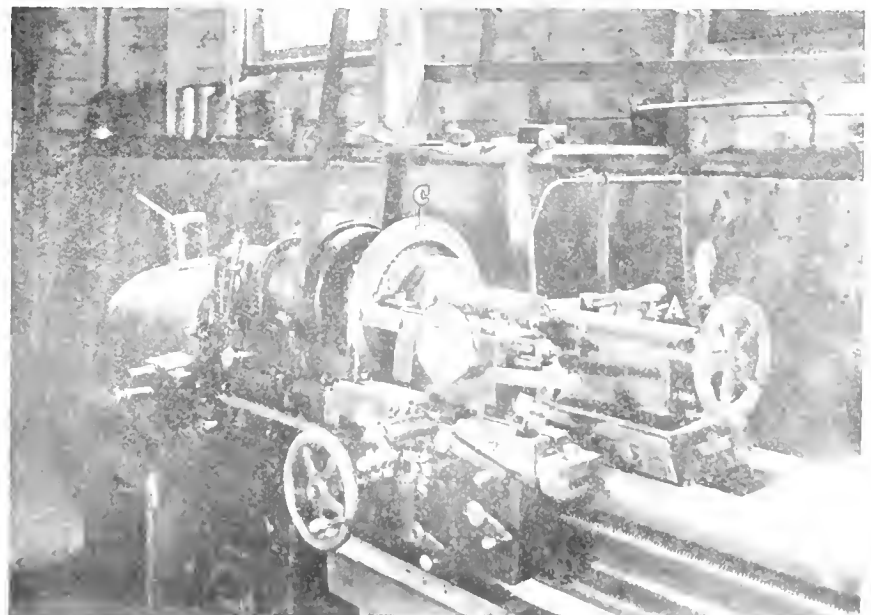

FIG. 5—FORMING THE COPPER BAND GROOVE

iron brackets, one of which can be seen near the headstock, and can be moved in them by set screws conveniently to the lathe, making a very convenient adjustment. A snap gauge is provided for

is used to form the base recess, a square turret mounted on the cross slide carrying the tools. A hogging cutter is first fed into a stop, leaving a light cut to be taken off the bottom of the recess,

While the saddle is held against the stop, the turret is drawn to the front to increase the diameter of the hole and also to bring into action a tool to face off the base and leave the riveting strip standing. The turret is next swung round and the tool shown in the illustration used to give the correct diameter and the perfect finish desired on the bottom of the recess. The shells are then gauged for base thickness, depth, and diameter of recess, the bottom being also carefully examined with a straight edge to see that it is perfectly flat.

Sand Blasting Shell Interior

Cleaning out the shells preparatory to sand blasting is rather a difficult job, but was solved finally by washing out with a jet of soda water and drying with rags on a stick. The sand blasting is done in a room made as nearly dust proof as possible. As a few grains of the steel shot, or sand left in the

the cross slide carries the tools. A roughing tool made so that it can be used to rough-face as well as rough-turn the diameter is first employed. The turret is then swung round and a finish facing tool used, a very light cut with this tool resulting in a perfectly finished and flat base plate. A tool with a projection at 30 degs. on one side brings the diameter down to size, and also forms the bevel at the back of the plate.

The base-plates are riveted in by an air hammer, the shell being revolved in a converted pipe machine. A holder for the hammer is arranged so that it can be swung out of the way to take out and put in a shell. The holder also carries a stop which when the head is brought forward by the foot lever, holds the base-plate securely in the recess. The square shank of the base-plate is cut off in a Racine draw-cut back saw, after which the shell base is faced off in a machine made by adding an old head-stock to the bed of one of the

the tightness of the base plates tested by tapping with a light hammer. Any shells which have the diameter of the base increased by the riveting are filed slightly to allow of the high diameter ring gauge to pass over. On being accepted by the Government examiners, the shells are lightly oiled inside and out, packed into regulation boxes, in lots of three, and shipped to the finishing plant.



DOMINION STEEL CORPORATION YEAR

THE changed character of Canadian steel production is shown strikingly in the Dominion Steel Corporation output figures for 1916. In the calendar year of 1914 the rail output amounted to 176,505 tons. It was 174,802 tons in the fiscal year 1912-13. In 1915 the output fell to 57,500 tons, and last year it was 174,495 tons. On the other hand, the output of wire rods has risen successively from 30,778 in 1914, to 73,500 in 1915, and now to 112,400 tons for 1916, while sales of wire products, which were less than 11,000 tons in the fiscal year 1912-13, have jumped to 47,500 tons.

These increases are a direct reflection of the export demand created by war conditions, and have resulted from the corporation's ability to diversify its output. Last summer, President Workman noted that the mills were then turning out twice as much barbed wire as six months previously, and the production at the end of 1915 had been about double the capacity at the outbreak of the war. The rail production, now little more than nominal, suggests post-war developments for the life of a rail is only so long, and annual replacement demands alone, deferred to the fullest possible extent since the war, should furnish substantial business when urgent war requirements cease.

An official statement of the corporation's output for the calendar year 1916, shows a new record in tonnage of ingots, the figures being about 8 per cent. higher than in 1915. Pig iron production was more than 12 per cent. in excess of the previous year's showing. Coal output was lower at about 4,500,000 tons, against 5,000,000 in 1915, recruiting and the shortage of shipping facilities entering as adverse factors. The approximate output of the various products is given as follows:—

	1916.	1915.	1914.
Pig iron	348,000	309,800	334,101
Steel ingots . .	376,000	349,000	331,000
Rails	17,495	57,500	176,505
Wire rods . . .	112,400	73,500	30,778
Wire products .	47,500	34,000	32,414
Blooms, billets, etc. . .	150,000
March bars . . .	9,950

Large expenditures were made during the year for improvements and extensions to the plant, as well as for renewals. The statement adds: "The tonnage of steel on order is sufficient to keep the works actively employed for several months, and, so far, there is no indication of any slackening in the demand for all the materials that the company can produce.

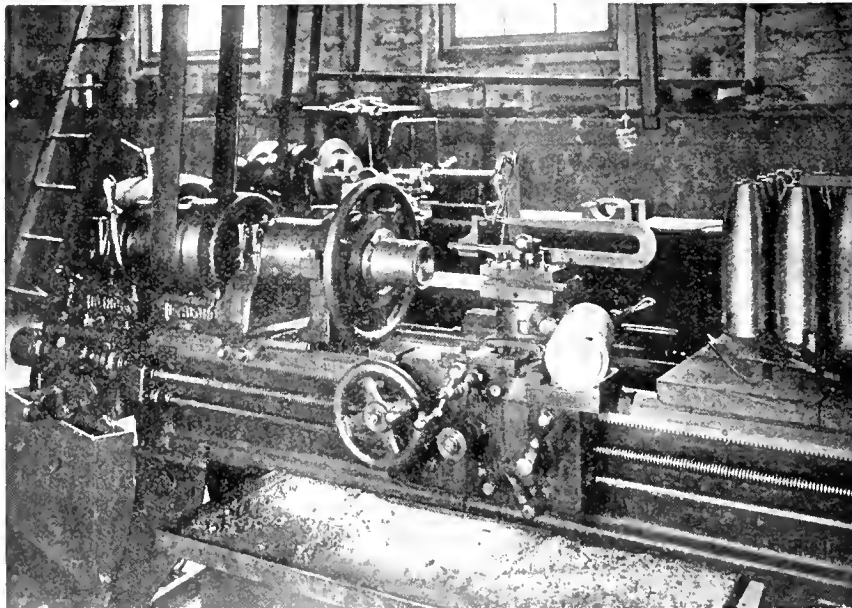

FIG. 6—FORMING THE BASE RECESS

threads would prevent the screw gauge from going down, care has to be taken that the threads are properly cleaned out. A shield with a few threads on it was made up to screw into the fuse hole and effectually prevented the shot from getting into the threads. An elongated electric bulb with a tin shield half-way round it is used to examine the interior of the shell to see that the sand blasting has been properly done. A complete shop inspection, supplementary to that given after each operation, now takes place, and rectifications made before the shells are submitted to the Government examiners. Rectifications were made on a Boyes & Emmes lathe, fitted with various convenient attachments and tools.

Base Plate Machining

The lathe on which the base-plates are machined is a 14-in. Sebastian product. A chuck to hold the square shank is secured in the taper of the head-stock spindle. A square turret mounted on

plant long lathes. A compound rest, to carry the tool, was also added. The tool is made of $\frac{7}{8}$ in. square high speed steel, and is arranged to cut on the end to get under the scale and afterwards to cut on the side to remove the excess metal.

The dimension limits for the distance from the base to the band recess being very small—about 1.32 in., care has to be taken not to remove too much. The weight, of course, has also to be watched. If a shell cannot be brought down to weight by removing metal from the base it is usually possible to get an ounce or two out of the inside profile. Care should be taken that the riveting is not cut away too much, this feature being due for consideration when determining the depth of the base recess. If the recess is deep enough there should be no fear of spoiling the work on this account.

The shells, before being passed into the inspection room, are weighed and

EDITORIAL CORRESPONDENCE

Embracing the Further Discussion of Previously Published Articles, Inquiries for General Information, Observations and Suggestions—Your Co-operation is Invited

REMOVING THE MONOTONY OF REPETITION WORK

By J. W. G.

THAT the monotony of repetition has a seriously depressing effect on factory workers is a fact, which, until recently, did not receive due recognition nor ameliorative effort on the part of employers. Constant production of the same article on the same machine, or repeated performance of certain physical efforts in a limited manner, may enable the operator to become expert and capable of rapidly repeating the motions because of their increasing familiarity. But some day, sooner or later, depending on the person's temperament, there comes a realization of the dehumanizing effect of the work, and another man quits, sick of the job.

A Familiar Simile

That such a sequence of events is only human can be shown at once by considering the elementary development of a child. In learning to walk, for instance, the danger of falls and excitement of effort maintain an interestedness and induce further effort until ability is fully developed. Then what happens? As soon as effort is thoroughly familiarized and becomes unconscious, the child wants to walk, not for the pleasure of simply walking, but of getting somewhere. If its efforts are confined to walking round and round in a circle, how long will it continue before the novelty wears off?

And yet such a state of affairs is exactly parallel to the conditions toward which many factory occupations are leading those who will be led. The simpler the work and the fewer the actions necessary to its performance, the more certain is it that the activity of the brain is gradually lessened until the output reaches a flat level. This is the stage when accidents most frequently occur in operating stamp presses, etc. That such a state of affairs demands a remedy is obvious to any broad-minded student of industrial economics; but whether it is possible to find a real cure is not immediately apparent. It has been suggested by certain authorities that if more care were taken to explain to operators the purpose of their task and the part it plays in production, the tendency toward intellectual revolt would be checked, and the systems of shop education which have been established by several progressive firms are evidence of organized effort in this direction.

Recent Growth of Monotony

But it would be foolish for employers to imagine that the burden of unending monotony can be alleviated to any great extent by lectures or demonstrations re-

garding the purpose or use of parts made by the thousand. Motor car production is an outstanding example of the conditions under consideration. In the early days, when production was small and evolution rapid, every employee in a factory had a personal interest in new models, and the numerous and sometimes radical changes in design maintained a spirit of expectancy among the workers which lasted from season to season; but the commercialization of the industry has removed the fascination of novelty and substituted the problem of production. While esprit de corps may have a stimulating effect in factories producing cars of particular reputation, the number of factories making component parts lack this feature in their output, and the probability of removing monotony there is just as remote as in the case of making tacks or punching links for chain belts. In none of these cases is the operators' state of mind likely to become more composed toward the work if the functions of a steering gear or a piston pin are explained in relation to a complete car; tacks are too commonplace and chain belt parts possess about as much individual interest as a brass time check.

Complete Removal Impossible

The present flood of shell production has called many workers who never handled a machine in their life, and, after some time, familiarity with the product induces an indifference which is

individuals are most concerned about.

No amount of moralizing will alter the fact that the monotony of repetition work cannot be removed. Education will either irritate, so that the operator will eliminate himself, or else induce him to become reconciled to fate; automatic machines may partly remove it, but, in the final analysis, the greatest comfort will be derived from the pay envelope. Drudgery will always be with us, and until some unforeseen change in conditions takes place, the stultifying effect of repetition work on operatives' intelligence can best be counteracted by giving them the means and opportunity of obtaining suitable counter-irritants or salves, free from factory influences or any taint of commercialized sympathy.



NICKING ATTACHMENT FOR SHELL NOSES

By A. F. White.

THE attachment shown in the accompanying sketch is designed for cutting the nicks in the nose of 4.5-in. Mark VII shells. It can be used equally well in milling machine, drill press, or small lathe, the sketch showing it in a drill press.

The cutter arbor is driven by the drill spindle, the lower end of the arbor being carried in a steady bearing bolted to table. The shell is carried in a revolving sleeve, the end next the cutter having a ring bolted on for supporting the shell

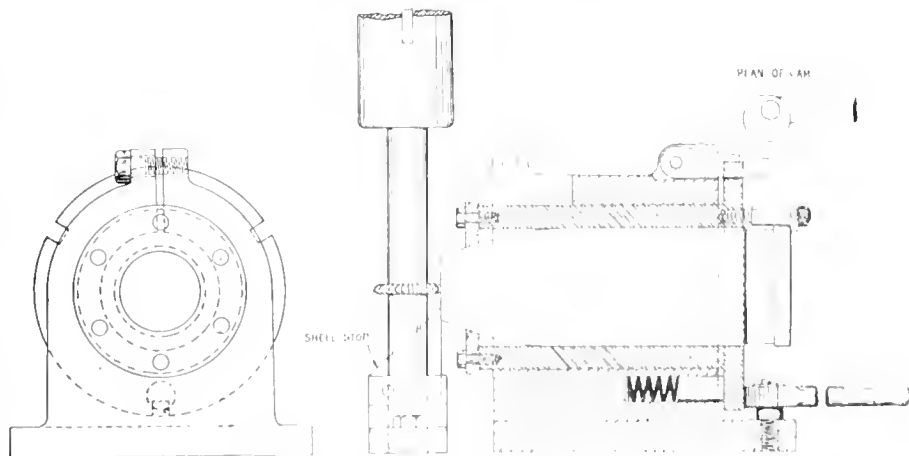

NICKING ATTACHMENT FOR SHELL NOSES

only kept in check by rigid inspection of product. The stimulus of personal interest in the course of hostilities is present with many of the workers, but lacks the permanent persuasion offered by adequate remuneration. When all is said and done, the prime object of labor is to earn an existence and to earn an amount of cash earned represents the degree of existence enjoyed, which is just what most

nose, and the opposite end flanged and provided with three slots for spacing the nicks. The shell is held in the sleeve by a tubular clamp carried on a stud, and is fed against the cutter by sliding the sleeve in the main casting by means of a levered cam mounted on the base and working against the side of the flange.

After milling each nick, the sleeve is

backed out by a spring plunger working against the inner face of flange, after which the locking plate is disengaged and the sleeve revolved by hand to the next position. The depth of nick is controlled by a stop-plate, carried by the arbor support, against which the shell nose makes contact. The main casting is bored a close fit for the sleeve and is split at the nose-end to allow of tightening up for wear and removing all shake.

The manner of using this attachment in lathes and millers is sufficiently obvious, the arbor being mounted horizontally and the main casting carried on the miller table or mounted on cross-slide of lathe.



OVER-MUCH DRILLING EFFICIENCY

By R. Hamilton.

ALL through the ages the question of efficiency, often more or less disguised, has been the bane of many a man's existence. During my apprenticeship in a large railroad repair shop, at a time when twist drills especially of the larger sizes, were considered more of a luxury than at present, the greater amount of heavy drilling being accomplished by means of flat drills. I recall an experience of "high speed" drilling that would appear to put the methods of today somewhat in the shade. The work consisted of drilling seven or more $1\frac{1}{8}$ inch holes in air-brake fork levers, using a block of wood between the two sections.

With a large pile of these on the floor, I was making satisfactory progress, operating the drill at the slowest speed of about 80 or 90 revolutions per minute, with a fair feed when the shop foreman came along, stood for a few minutes looking at the pile on the floor and the action of the drill alternately. Seeing the master mechanic coming down the shop, he suggested that I "throw her up" on the next speed. Without comment I did so, and with a partially concealed smile he walked away, only, however, to be replaced by the master mechanic, a moment or two later. He, after a brief survey of the situation, asked if the drill could not be run on a higher speed. I said it could, but did not think the drill would stand it. He pooh-poohed the idea, and further suggested that I again increase. Almost immediately thereafter, he told me to keep it there and proceeded on his way: just like some bosses who jump into a hole and throw clouds of dirt out in an effort to demonstrate to the operator how he should work, with no apparent realization that what may be possible for a short time is impracticable for an extended period. So, in this instance, with a sharp drill, lots of lubricant, and increased speed, the output for the moment, so to speak, contributed to the greater efficiency achievement impression with which the master mechanic had disappeared from the scene.

The duration of the "test," however,

was well within the time required to drill two complete holes, and it was no surprise to me that the drill needed grinding before starting the third hole, and that, after finishing two more, the size of the drill had been destroyed. This of course necessitated a trip to the blacksmith shop for redressing and tempering the drill, which after drilling six or eight holes required to be repeated.

On returning from one of these journeys to the "adjusting bureau" the foreman was waiting at the machine to inquire of my progress. Upon learning that the output had decreased over 50 per cent., owing to the extra time spent at the grindstone and tool dresser, he started to "call" me for not reducing the speed, but I suggested that his remarks be reserved for the "chief", as I was only obeying his orders. This, resulted in closer attention being given to the details of operation, and after several demonstrations, the original speed was decided on with a slight increase in the feed, which goes to show that speed is only one of the factors in the problem, and its elimination often aids in solutions for economic efficiency.



A BELGIAN BALL-TEST MACHINE

By J. W. G.

THAT increasing recognition is being given to that quality in metals generally termed hardness is evidenced by the number of machines which are now available for testing purposes. Among the different methods in use, the ball test has always occupied a prominent place. The Brinnell system being a standard for certain classes of work. This fact, together with the present terrible tragedy in Belgium, imparts a peculiar, almost a morbid interest to the device illustrated herewith.

In pre-war days an international reputation as a producer of the highest grade of forgings was enjoyed by the Usines G. Derihor Societe Anonyme, Louvain (Lez-Liege), and the ball testing machine illustrated herewith was developed in the Derihor shops and used in their work regularly. The writer first saw this machine about seven years ago and feels that the peculiar features of the machine, coupled with changed conditions, make it of special interest to your readers at this time.

The method of operation consisted in pressing a 10 mm. hardened steel ball

into a specimen of the material, and measuring the diameter of the impression on different specimens of the same material. The frame of the machine was a hook-shaped forging of narrow channel section, the lower end terminating in a large boss containing an elevating screw for the table, while the upper end carried a pressure screw and testing ball. When pressure was applied to the ball, through the double-ended wrench on top of pressure screw, the resultant stress caused the gap in the frame to open, the frame being so designed and proportioned that regular increments in load were accompanied by equal amounts of distension in the frame without the stresses being near enough the elastic limit to affect its permanent resistance. In other words the frame acted as a very strong spring.

The amount of deformation imparted to the frame was indicated by a simple lever and pinion arrangement shown clearly in the illustration. A small channel section member was fastened to the base of frame, fitting the curve to a point near the pressure screw. Here the member terminated, a knife edge being formed on the end to support a hinged member which carried a rack at its lower end, this rack engaging with a pinion on the indicator spindle. As the bending of the frame took place above the point where the small channel member was attached, relative movement between their upper extremities ensued, so that the hinged member descended as its hinged end was raised, allowing the rack to travel across the pinion and revolve the indicator.

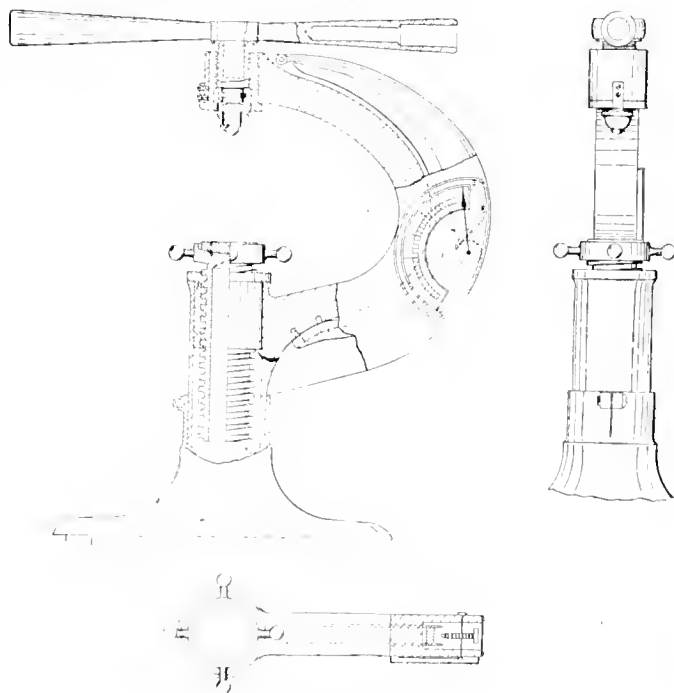

BELGIAN BALL TEST MACHINE.

The diameters of impressions were measured by a glass gauge similar to a wire gauge. By carefully observing the contact of the tapered lines with the edge of impression, an empirical number was obtained which could be re-

ferred to any other specimen provided the same pressure was used in making the test. The maximum pressure applied varied with different materials, the chief point being to get a medium sized impression where possible without injuring the work unnecessarily. Where standard grades of material were in constant use, suitable pressures were specified so that measurements with the scale were then comparable.

To the writer's knowledge, these machines were at one time on the market in the United States. Many dark days have passed over its land of origin since then, the Derihon factory at one time being reported in operation under German control; recent developments, however, create considerable misapprehension regarding the men and plant who were responsible for the development of the machine.

HUMAN FACTOR IN THE WORKSHOP

By J. Wright.

PRESENT-DAY competition has become so keen that the scientific and mechanical world are working at high pressure devising ways and means to increase the quality and quantity of manufacturing output at a minimum expenditure, both of money and material. It is only within the past few years, however, that any great amount of consideration has been given the general betterment of conditions under which employees operate in industrial establishments. It is encouraging, however, to note that the value of the human element is being more and more appreciated at its true value.

There was a time when the average workman was for the most part recognized as simply a piece of machinery, capable of working long hours and under almost any conditions. Many things have transpired to prove the fallacy of such a belief, with the result that employers are giving more attention to the welfare of their help than ever before. Progress in this direction has not only proved beneficial to the workmen, but results have shown that a higher standard of production is maintained in those factories where the environment tends to the "uplift" rather than the "depress," the latter of which is more or less associated with dismal and unsanitary surroundings.

Examples might be cited where material gain was falsely considered of more importance than the health or welfare of the employee. Some years ago on a certain machine, the "boss" had considerable difficulty in keeping it in continual operation owing to the irregular attendance of the operator, who was absent quite often as a result of contracting heavy colds, due to the draught created by the opening of a nearby door. A screen was suggested, but nothing was done until the season arrived when artificial light was necessary. The open gas jet could not protest against the draught, but, as the light was essential, a screen was erected to "protect the light," and

thus provide a better opportunity for the man to work.

On another occasion the superintendent was showing a visitor about the works, and happened through the galvanizing department at a time when some tanks were being supplied with fresh acid. The visitor lost no time in seeking the freer atmosphere of the adjoining room, remarking to his host that he would not work in such a place for \$20 a day. The boss replied that "the men did not mind it; in fact, they actually eat the stuff." This was probably true, and they were doing it for much less than \$20 a day, or even a week, while in reality the fumes from the acid were slowly consuming them as the days rolled by. However, not long after this visit facilities were provided to aid in carrying off the poisonous fumes and permitting healthier working conditions for the employees.

When more thought is given to the efficiency of the workmen through the agency of the human touch, by incorporating suitable and sanitary environment with that of their daily tasks, the ever present problem of shop efficiency will become less complex.

THREAD INDICATORS

THE little device often found on lathe saddles and on some screwing machines, variously known as the thread indicator, pitch indicator or dial indicator, is an extremely useful arrangement if used intelligently. Owing to the large number of untrained workers now operating, or being taught to operate, machine tools, it may not be out of place if we endeavor in what follows to explain the principle and use of this indicator, thus substituting understanding for rule of thumb.

If anyone desires to make the device, it is a simple matter to attach it to the machine. Fig. 1 shows the indicator as fitted to a Lodge & Shipley lathe. A hole is drilled underneath the wing of the

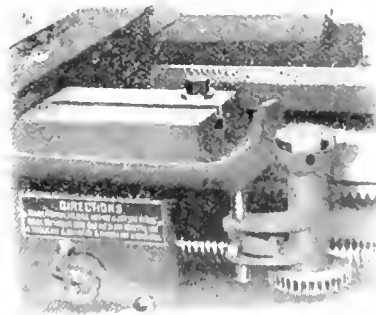

FIG. 1

saddle and a turned pin fitted in it. The bracket which carries the worm wheel and dial is free to swing on this pin; it is, however, kept by spring pressure with the worm wheel, in mesh with the lead screw. This spring pressure is furnished by means of the finger seen beneath the two arms of the bracket. This finger is locked on the pin by a set screw and a

small helical spring is fitted between its end and the bracket. The worm wheel should have teeth of the same pitch as the lead screw, while the number of teeth should be a multiple of the number of

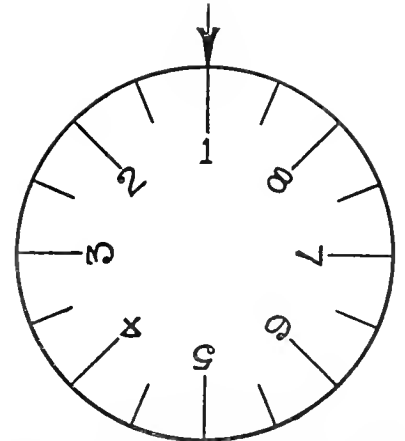

FIG. 2—THE DIAL SHOWING 8 NUMBERED AND 8 UNNUMBERED GRADUATIONS

divisions on the dial depending on the pitch of the lead screw. Examples:—

Pitch of Lead Screw.	Divisions Dial.	Teeth in Worm Wheel.
2 tths. per in.	8 or 16	16 or 32
4 tths. per in.	16	32
6 tths. per in.	16	48

The dial and worm wheel must be connected in such a way that, when the half nuts are engaged, a graduation on the dial must be opposite the index mark or pointer. When using the indicator, the saddle can be run back by hand and the half nuts re-engaged at the proper point without fear of cross-threading. Its use entirely obviates the necessity for a reversing countershaft or for the old-fashioned method of chalking the work and the lead screw. In principle, the thread indicator is a device for showing the operator when the work and the lead screw are in register one with the other.

Each revolution of the lead screw when the half nuts are disengaged causes the worm wheel to rotate one tooth—that is, provided the lead screw is single threaded, which most of them are. Each division of the dial corresponds to a certain number of teeth in the worm wheel. Assuming that the dial is graduated as Fig. 2, then the number of teeth of the worm wheel, and consequently the number of revolutions of the lead screw, that will cause the dial to rotate one division, will be as follows:—

Teeth in Worm Wheel.	Revs. of Lead Screw to Make Dial Rotate One Division.
16	1
32	2
48	3

When the screw-cutting tool is taking the first cut over the work, everything is in register. If that register is disturbed, as it is by disengaging the half nuts at the end of the cut, the half nuts must only be re-engaged for commencing another cut when everything is in register again. This will only occur when both work and lead screw have made a whole number of revolutions in the same ratio as the number of threads per inch being cut and the number of threads per inch of the lead screw. For instance, if cutting, say, 14 threads per inch, and the

lead screw has 4 threads per inch, then, from being in register to coming in register again, the work must make seven complete turns to two of the lead screw, these being the smallest whole numbers in the ratio of 14 and 4. If cutting, say, $11\frac{1}{2}$ threads per inch, then work and lead screw must make 23 and 8 revolutions respectively before all is in register again.

The reason for this is the fact that work and lead screw are geared in the same ratio. Imagine an unthreaded piece of work in the lathe and a pointed tool in contact with it. If the machine is started with the half nuts engaged, the tool marks a path on the work, this path being an incipient screw thread. Next imagine the machine at rest, the tool touching some point on the marked path and the half nuts engaged. Everything is in register.

If now we disengage the half nuts and revolve the lathe face-plate by hand, we find that the work and the lead screw have to make a certain number of revolutions before they are in register again—the revolutions made will be in the ratio of the threads per inch on work and lead screw. While all this is being done, it will be noted that the dial is also rotating, and register is obtained when a division mark is opposite the pointer. If we repeat the operation, we shall find register again occurring with a division mark opposite the pointer.

Next let us imagine some specific numbers of threads to cut and carry out this operation, noting the division marks opposite the pointer each time register is obtained. It is assumed that the dial is graduated as in Fig. 2, and the following factors hold good. There may be exceptions, but they do not affect the principle, and they will be few and far between.

Thds. per in. of Lead Screw.	Teeth in Worm Wheel	Rev. of Lead Screw to make Dial Rotate one Division
2	16	1
4	32	2
6	48	3

First, take an even number of threads per inch to be cut on the work. Register is obtained when the work has made the same number of revolutions as the threads per inch. At the same time the lead screw will have made two, four or six revolutions, according to its pitch. As all even numbers are divisible by two, register is obtained when the lead screw has made either one, two or three revolutions, which, according to the table above, occurs when any division mark comes opposite the pointer. Therefore, when cutting an even number of threads per inch, the half nuts can be engaged when any division mark is opposite the pointer.

Next take an odd number of threads per inch. As such a number is not divisible by two, register is only obtained when the work and lead screw have made the same number of revolutions as their respective threads per inch. That is, the lead screw must make either two, four or six revolutions, according to its pitch. Therefore, when cutting any odd num-

ber of threads per inch, the half nuts can be engaged when any numbered division is opposite the pointer.

Fractional threads are those including a fraction along with a whole number in the number of threads per inch, as, for instance, $11\frac{1}{2}$, $2\frac{1}{4}$, and so on. These numbers must be multiplied by the denominator of the fraction to bring them to the lowest whole number of revolutions that the work must make before register is obtained. Half threads must be multiplied by two; so also with the threads per inch of the lead screw. Therefore, when cutting threads, including $\frac{1}{2}$ in the number of threads per inch, the half nuts can be engaged when the dial has made a quarter revolution.

Quarter threads require multiplying by four; so also with the threads per inch of the lead screw. Therefore, when cutting threads including $\frac{1}{4}$ in the number of threads per inch, the half nuts can be engaged when the dial has made a half revolution.

It is wise when commencing to cut fractional threads to see that the dial has a numbered graduation opposite the pointer, as this makes it easier to reckon the half and quarter revolutions. When we have to cut threads involving some odd fraction in their number per inch, such as 14.083, then the dial indicator is of much less value. The only way is to mark the work at the end where cutting starts, and to only engage the half nuts when the mark and, say, the number one graduation come in register at the same time.—*Herbert's Monthly.*



CANADA'S 1916 COAL OUTPUT

THE Dominion Department of Mines has received from the principal coal operators in Canada returns of their production for ten months, supplemented in most cases with estimates for November and December.

On the basis of the record available, it is estimated that the total production of coal in Canada during the calendar year 1916 will approximate 14,365,000 short tons (equivalent to 12,825,892 gross tons). The estimate is believed to be fairly close for Nova Scotia and British Columbia. In Alberta, however, there are so many small operators that final returns may show a wider variation from the estimates now made. By provinces the estimate is as follows, the figures for 1915 being included for comparison:

	1915.	1916.	Inc.
N.S.	7,463,370	6,950,000	*513,370
N.B.	127,291	135,000	7,709
Sask.	240,107	260,000	19,893
Alberta	3,360,818	4,400,000	1,039,182
B. Columbia ..	2,065,613	2,620,000	554,387
Yukon	9,724
Total	13,267,023	14,365,000	1,097,977

*Decrease.

The 1916 production exceeds that of the two previous years, the increase over 1915 being about 8 per cent. Nova Scotia is apparently the only province that has not made an increased production, the falling off in this province being a little less than 8 per cent. The in-

crease in Alberta is nearly 32 per cent., and in British Columbia nearly 27 per cent. The production in New Brunswick, Saskatchewan and British Columbia is the highest on record. No estimates are available yet as to the Yukon output.



CONCERNING SUPPLIES FROM UNITED KINGDOM

MERCHANTS, manufacturers, and the general public are urgently requested to refrain from applying for permission to obtain materials and supplies from the United Kingdom, unless the same are required for war or other urgent national objects. It is essential that supplies in the United Kingdom should be conserved for direct war work and work of urgent national importance.

So runs a notice issued to Canadian manufacturers and others by the Trade and Commerce Department, Ottawa. It brings to light the fact that the restriction of export of a large number of articles by the British authorities has become a matter of serious import to Canadian trade, and the work of seeing that necessary exceptions are made to the general restriction in favor of national importance in the Dominion is keeping the Trade and Commerce Department busy. On the restricted list are commodities such as tin plate, tin sheets, wire rope, boilers, machinery parts, tool steel, hoisting cable, etc. A number of these are articles directly, and in other cases indirectly, required in the manufacture of munitions, so that every effort is being made to see that Canada obtains enough for such requirements.

In connection with all applications to receive shipments from the United Kingdom of goods on the British export restriction list, there is now being required detailed information as to the nature of the goods and their purpose. Such information includes:—Names and addresses of exporter, Canadian consignee and actual user of goods; quantity and descriptions; purposes for which required; whether or not goods might be substituted; why the goods required could not be purchased in Canada or the United States; degree and proof of urgency and consequences should application be refused; if goods are for stock purposes what is normal stock; stock on hand; average call on stock per month; stock it is desired to hold. When such information is furnished to the Trade and Commerce Department, the latter requests the Canadian High Commissioner in London to support the exporter's application for the issue of a priority certificate by the Minister of Munitions which is a necessary step before export licenses may be issued by the War Trade Department at its discretion.

Representations have been made to the Trade and Commerce Department with particular relation to the import from Great Britain of wire rope. The restriction of its export has been particularly felt by the lumber and mining industries of British Columbia.

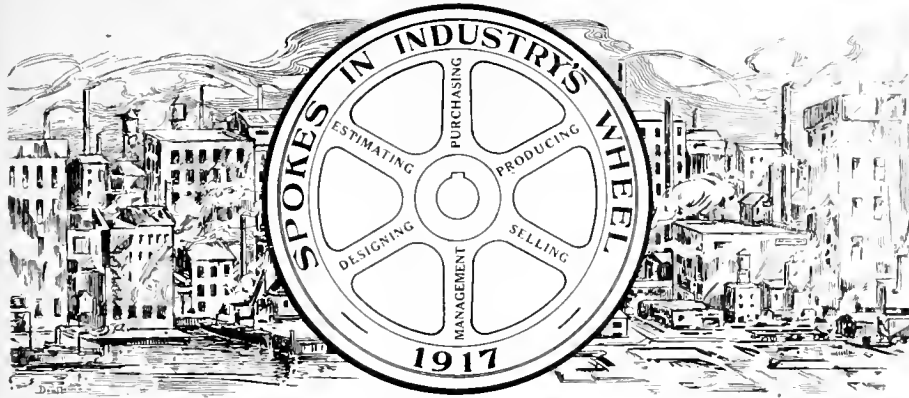

The constitution of industrial enterprise is largely departmental—"spokes in a wheel." This series of articles has for its object the featuring in a racy, interesting and instructive fashion, the training, experience and achievement of those who to-day are transmitting, effectively, energy in their capacity as "spokes in the wheels" of our metal-working establishments.

JOHN SHARP

THE war-created prominence accorded shipbuilding and marine engineering on this North American continent has had the specific effect—and more especially in Canada—of bringing into the limelight a section of the industrial community, who, from lack of demand for their handiwork, had been, if not altogether outside the pale of nation builders, at most but contributory in much restricted degree. John Sharp, chief engineer, Polson Iron Works, Toronto, Ont., is of the number. His firm, in common with others recently or long established, have not only their every available shipbuilding berth filled with ocean-going freighters in varying stages of construction, but carry on their books a sheaf of contracts for vessels of a like type, calling for earliest possible delivery, and, making necessary as a result, plant extensions ranging all the way from 100 to 200 per cent. normal or pre-war capacity.

John Sharp—what the name lacks in ornamentation it expresses in keenness, relative to personality or otherwise—was born at Brantford, Ont., May 26, 1886, of Canadian-by-birth parents—Benjamin and Rachel (Near) Sharp, who, it may be stated, also first saw the light under our Dominion sky. He received his education in the public and high schools of his native city, following which, during the years 1902-1906, he served a four years' apprenticeship in the draughting office of the Waterous Engine Works. In the latter year he joined the engineering staff of the Dymont Foundry Co., of Barrie, as chief draughtsman, occupying that position until associating himself with the Canada Foundry Co., Toronto (now Canadian Allis-Chalmers Co.), in 1908. The variety of experience gained in the plants above enumerated laid, as it were, the foundation for not only an enlargement of the scope of John Sharp's general mechanical engineering bent, but developed both his inquisitiveness and acquisitiveness relative to other fields of metal-working activity.

In 1910, therefore, we find him transfer his services from the Canada Foundry Co. to the engineering department of the Polson Iron Works, and here it may be in order to say that, with his promotion to the post of chief engineer of the latter concern some four years ago, he has found opportunity for the exercise of his skill in a specific class of product to which his endowment of talents has been naturally adapted. The manufacturing output of the Polson Iron Works covers a wide range, embracing as it does general mechanical, steam, and marine



JOHN SHARP

engineering, shipbuilding and ship-repairing, and, when it is remembered that John Sharp's experience previous to 1910 was largely, if not altogether, confined to engineering equipment for ashore service, much credit is due him for the apt—*sharp*, if you like, way he has in these recent years appropriated to himself an honored place among Canada's naval architects and marine engine and boiler designers. With the practical certainty of a decade of more or less abnormal activity in shipbuilding and marine

engineering within our borders, his star with respect to same is likely to continue in the ascendant.

Mr. Sharp is unmarried, although quite as eligible to pass from that state to the other as to develop into a naval architect from eight years' experience as a mechanical engineer; besides, and judging from his devotion to his chosen and adopted craft and calling, there is little doubt but that a like disposition would mark his matrimonial enterprise, and, therefore, in course its equal success. We might say that in the few brief moments during which the more personal data connected with this career sketch were being acquired, our single or married query brought out the information—single [at present], the words in brackets being, however, hastily withdrawn. The outlook, needless to say, gives promise of a thinning out of the ranks of bachelorhood at an early date.

In politics, Mr. Sharp says he is Independent, which, in nine cases out of ten as regards the engineering fraternity generally, means that little or no interest is taken—lack of time, and little or nothing in common, being good and sufficient reason for not taking sides. In religious creed he is Anglican—engineers are usually found associated with progress and uplift, and, therefore, belong to one or other church denomination. In matters military, he holds a commission in the 12th Regiment, York Rangers, a circumstance by no means surprising when account is taken of the prominent part that engineering of every kind is playing in this great European war. He had as a matter of fact enlisted for Overseas Service and had quit his work, but because of the equally important duty of helping to eliminate the shipping shortage, his recall was officially ordered. He is a member of the A.F. and A.M., the Engineers' Club, Toronto, and of the Society of Naval Architects and Marine Engineers, New York. His residence is at 121 Carlton Street, Toronto.

"The engineering profession," says Mr. Sharp, "embracing as it does so many branches and departments, presents a variety of opportunity to every young engineer or mechanic who cherishes the desire to advance. He should, therefore, concentrate both his studies and his energies along one line until that is mastered, both in theory and practice. Present-day educational facilities—technical schools, technical and trade papers, technical and practical text books, are available and within easy reach, furnishing reliable stepping stones to position after position of advantage, regardless of initial circumstances or vagaries of environment."



Phosphorus is considered by many brassworkers to be the only deoxidant of value in dealing with copper alloys. It is, however, frequently added to excess, when it becomes injurious. A proportion of 0.25 per cent. is the maximum permissible while 0.10 to 0.15 per cent. is ample for all ordinary purposes.

PROGRESS IN NEW EQUIPMENT

A Record of New and Improved Machinery and Accessories for the Machine, Pattern, Boiler and Blacksmith Shops, Planing Mill, Foundry and Power Plant

MOTOR DRIVEN TAPPING MACHINE

IN constructing the tapping machine illustrated herewith, the designers had as their object a high-grade tapping machine in which the cutting speed can be varied without affecting the time per operation, that is, having increased reverse speeds to compensate for slower cutting speeds, conjointly with this be-

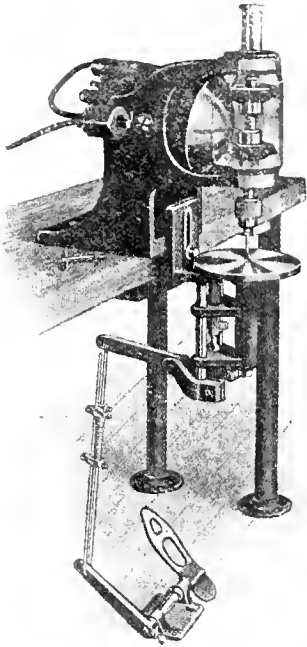

MOTOR DRIVEN BENCH TRAPPING MACHINE.

ing an efficient type of motor drive which would transmit a maximum amount of power so that the machine might be run on ordinary lighting service wire without undue overload.

The machine is of the vertical drill press type, having a high carbon steel spindle mounted in ball bearings top and bottom, the inner ball races, in which the spindle moves endwise, being increased in length by pressed-in sleeves, fitted very accurately to the ground spindle. An enclosed spring balance is fitted to the upper end of the spindle, adjustment being provided to suit the weight of the spindle and related parts.

Friction drive is employed between the motor and spindle, a spherical disc being mounted on the end of the motor shaft, and engaging with the convex edge of two friction discs on the spindle. As a result of the curved line of contact obtained by this arrangement the tendency to slip is largely reduced. The motor is pivoted in the frame of the machine on the same centre as the spheri-

cal friction disc, so that by tilting the motor, various cutting and return speeds can be secured, any decrease in one direction resulting in a corresponding increase in the other.

The circular work table is 7 in. dia. and has a vertical movement of $1\frac{3}{4}$ in., being guided by two way-rods which can be adjusted vertically 3 in. A balance spring below the table makes the movement of the tap very sensitive when doing small work. The table is operated by foot treadle, a safety spring being fitted to prevent spoilt work through too sudden pressure on the treadle. The lower part of the table is hollow and acts as a lubricating well, the taps dipping in and being cleaned at each stroke of the table.

This machine is built by the Anderson Die Machine Co., Bridgeport, Conn., and is distributed in Canada by the R. E. T. Pringle Co., Toronto. The net weight is 115 lbs., and it has a capacity with standard taps of 1-16 in. to $\frac{1}{4}$ in. in cast iron, 1-16 in. to 3-16 in. in steel, with a depth of $1\frac{1}{2}$ in.



SINGLE PURPOSE HIGH SPEED DRILLING MACHINE

THE heavy vertical drilling machine illustrated in the accompanying cuts is intended for single purpose manufacturing work to drive $1\frac{1}{2}$ in. high speed drills to the limit of their efficiency in steel. Simplicity of design and rigidity of construction characterize this machine, which, while built for quantity production, is capable of performing a wide range of work with little change.

The frame is of the two-piece type, the lower or column portion having its front face machined to take the elevating table which is gibbed thereto. The upper or head-stock portion is securely bolted to the column and carries all the driving gear and feed mechanism. The spindle is machined from a high carbon steel forging, having a No. 5 Morse taper hole in the nose, which is slotted across for driving heavy boring and facing tools. The sleeve which carries the spindle is supported in bearings for its entire length, and is fed by hardened

nickel steel rack and pinion, the worm gear on the pinion shaft being fitted with a safety shear pin to protect the feed mechanism from overload.

Change gears are employed to vary the spindle speed from 76 revs. per min. to 614 revs. per min. while by changing the top driving gears, speeds one half and one third of these are obtained.

Feeds also are varied through change gears, a reaming feed 3-1.3 times the drilling feed being provided. Six feeds are provided on the standard machine, reaming from .020 to 0.89 in. and drilling .005 to .024 in. per revolution of spindle. Considerable attention has been given to the locating of the operating levers, in order to make them suit the logical movements of the operator. Tight and loose pulleys are used for controlling purposes, and a spring device holds the belt slipper securely in either position. When in the off position, a brake is applied to the spindle to secure prompt and effective stoppage. The change from drilling to reaming speeds is made by push rod at left of spindle.

These machines are well suited for gang arrangement, a four spindle unit being illustrated herewith, either continuous or independent tables being furnished as required. Elevating screws are provided for the tables which are constructed so that they can readily be pushed for boring bar. From center of spindle to face of column is 10 in.; from end of spindle to plain table 32 in.; length of feed, 12 in.; vertical adjustment of table, 18 in. The single machine requires 29 in. x 46 in. floor space

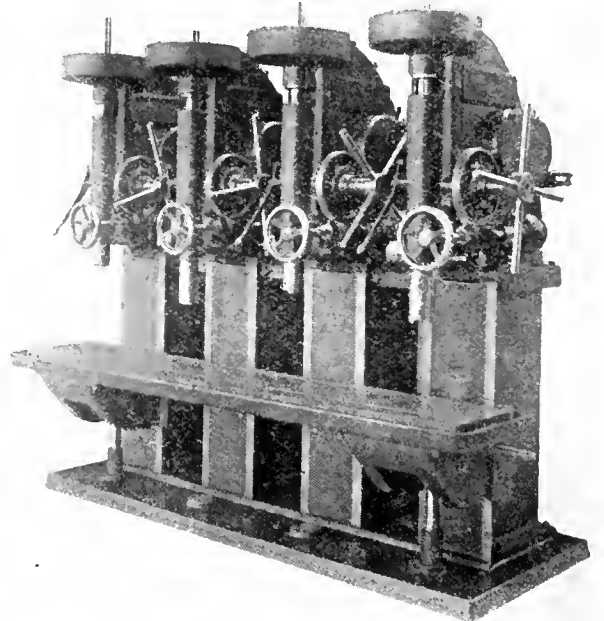

GANG ARRANGEMENT, SINGLE PURPOSE HIGH SPEED DRILLING MACHINE.

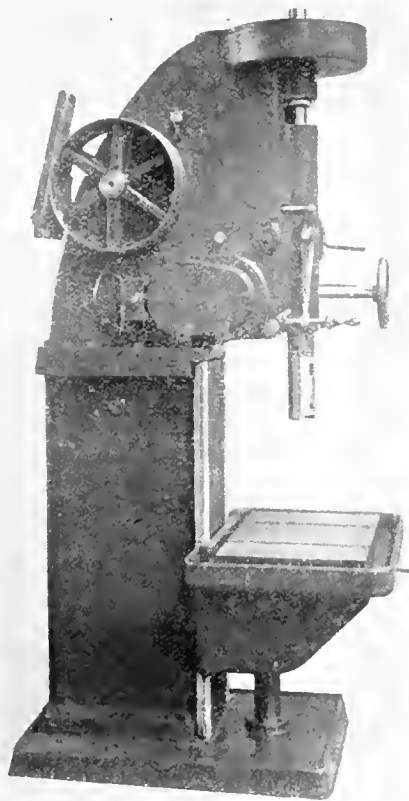

SINGLE PURPOSE HIGH SPEED DRILLING MACHINE.

and weighs 2,550 lbs. A four spindle gang requires 101 in. x 46 in. floor-space and weighs 10,250 lbs.

The makers of this drilling machine are Baker Bros, Toledo, O.

PRESS FOR STAMPING WASHERS FROM SCRAP PLATES

SCRAP sheets and plates bring a small price when sold as scrap, but when punched into washers realize a much higher figure. The press shown in the illustration herewith is specially adapted for making washers and other stamped specialties from scrap plates and sheets or from new material, its most useful field being in the utilization of waste material by converting it into standard or special washers, large quantities of which are always used around railroad and industrial plants.

The frames are one solid casting of the open gap type, on which is mounted the gearing (a single reduction except in case of motor drive) plunger, cam shaft, dies, etc. The plunger has broad wearing surfaces and is equipped with a bronze taper gib to take up any wear. Fastened at the bottom is the die and piercer, the former for cutting the outside of the washer, and the latter for punching simultaneously the centre hole. The punch is on the bottom and is held in a substantial punch holder block on the lower jaw of the frame.

Surrounding this punch is the stripper ring, operated through connecting rods and lever from a cam on the back of the main shaft. In an annular space between the piercer and die are a series of

knockout pins for knocking down the washer which sticks in the upper part of the die mechanism and goes up with the upward stroke of the plunger. These pins are operated by a bar passing cross-wise through the ram and, at the top of the stroke, stopping against a pair of set screws in lugs cast on the frame.

At the left front side of the machine is a vertical shaft which is splined at the top with a steep pitch thread. This passes through a nut which is fast to the top of the plunger. The up-and-down stroke of the ram imparts a rotary motion to the shaft. On the bottom of the shaft is the hand or cup which receives the knocked out washer and throws it into a pile or suitable receptacle.

The back of the main shaft is equipped with a tight pulley as is also the fly wheel shaft. This pulley drives the machine on light work when operated the same as a fly-wheel non-g geared press. In this case the fly-wheel, pinion and shaft are removed. Operating without gears makes the machine a rapidly acting press the speed being limited only by the skill of the operator handling the material.

The machine may be used for various forms of stamping, punching, shearing, etc. Where used for scrap reclaiming only, it may be placed at the scrap bins. Only one man is required to operate it, he using both hands to hold the material as the ram operates continuously. By a special die construction, the press makes a complete washer at each stroke of the ram, insuring the concentricity of hole with the outer circumference. It leaves the washer perfectly flat and with clean-cut edges. The punched washer is thrown out automatically into a box or to a pile by a mechanical hand operated from the slide.

The machine is equipped with a pulley for belt drive or, when specified, motor bracket and suitable gearing for electric motor drive and one set of punches and dies for any size within range of the

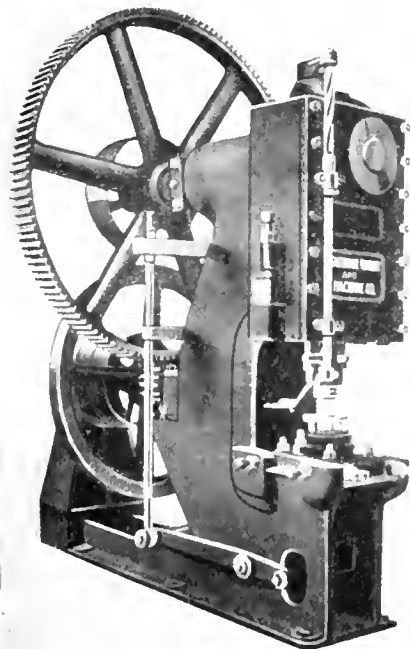

WASHER STAMPING PRESS.

capacity. Five sizes of this machine are built by the Southwark Foundry & Machine Co., Philadelphia, Pa.

CANADA'S IRON OUTPUT

REFLECTED in Canada's largest production of iron and steel, are the output of the munitions industry and the larger domestic requirements of last year, together with exports of billets and wire. J. McLeish, B.A., chief of the Department of Mines, division of statistics and mineral resources, has compiled the following table. The summary of iron and steel statistics, 1914-1915, are as below:—

	1914.	1915
	Short tons.	Short tons.
Iron ore shipped	244,854	308,112
Canadian iron ore charged to blast furnaces	182,964	203,305
Imported iron ore charged to blast furnaces	1,324,326	1,314,957
Iron ore charged to steel furnaces	57,686	74,872
Pig iron made	783,164	913,775
Pig iron and ferro-alloys exported	19,063	26,545
Pig iron imported	78,680	47,842
Ferro-alloys made	7,524	10,794
Ferro-alloys imported	22,147	13,758
Pig Iron and ferro-alloy consumption	782,452	930,254
Pig Iron used in steel furnaces	619,030	747,834
Steel ingots and castings made	828,641	1,020,336
Steel rails made	428,225	232,411
Canadian coke used in iron blast furnaces	330,269	578,743
Imported coke used in iron blast furnaces	590,902	86,022
Iron and steel imported....	878,179	771,007

THE BET

CHILDREN are never quite so ignorant as we think they are. There is a London man who said to his little daughter one evening:

"Now that the stork has brought you a dear little baby brother, I want you to sit down and write a nice letter about it to Brother Jack at boarding school. Tell him we went out and looked under one of the big cabbage plants, and there we found a dear, sweet baby brother, with blue eyes and red hair, that the kind stork left for us."

"Yes, papa," said the little girl, meekly.

She wrote her letter, and when her father went to post it, he thought, since it was not yet sealed, that he'd see what she had said.

What she said was this:

"Dear Jack, I win the money. It's a boy."

A Moving Appeal.—"Yes," said the naive young person, "we invited three soldiers for dinner on Christmas Day. We felt we just had to, for mother said it was a crime to eat turkey at 42 cents a pound unless we had some sort of excuse for it. So we hunted one up quickly, and we never had such a delightful Christmas as we did entertaining three perfect strangers. What about them? Well, they stayed until nearly twelve o'clock, and I think they'd be here yet, smoking cigarettes, if one of them hadn't happened to be Scotch, and we suggested that they would have to be taking night cars very soon!"

The MacLean Publishing Company

LIMITED

(ESTABLISHED 1888)

JOHN BAYNE MACLEAN President
H. T. HUNTER Vice President
H. V. TYRRELL -General Manager

PUBLISHERS OF

CANADIAN MACHINERY AND MANUFACTURING NEWS

A weekly newspaper devoted to the machinery and manufacturing interests.

PETER BAIN, M.E., Editor. B. G. NEWTON, Manager.
Associate Editors.

A. G. WEBSTER. J. M. WILSON. J. H. RODGERS.

Office of Publication, 143-153 University Avenue, Toronto, Ont.

Vol. XVII. JANUARY 11, 1917 No. 2

THE PAPER SITUATION.

IN view of the continued seriousness of the paper situation in Canada, and of its perhaps no less acuteness in the United States, it may not be without interest if we refer to some observations made by our contemporary the Pulp and Paper Magazine relative to the scarcity and high cost of newsprint and other publication stock. In a recent issue, a two-fold protest is lodged. On the one hand, protest is made against the danger and injury which will come to the whole pulp and paper industry if the chief interest in the manufacture of paper is to be centered in the stock market; on the other, exception is taken to inclusion of paper stocks in the "war baby" class.

"Canada," to quote some of the data given, "owns 40 per cent. of the world's supply of pulpwood, but at the present time only produces 5 per cent. of the world's paper. The United States, on the other hand, owns but 18 per cent. of the world's pulpwood supply, yet produces 42 per cent. of the world's paper production. When Canada comes into her own as a paper-making centre and produces 40 per cent. of the world's supply instead of 5 per cent. as at present, people who now scoff at the paper industry will have a chance to revise their opinions. Again, even if peace were to come tomorrow, the present prices prevailing for paper will be maintained for a year or two at least."

In recent months—we "make no bones about it," our readers have been called upon to pay a higher subscription rate for this journal, added to which the paper quality is less substantial and the space devoted to their interests, compressed by using closer faced and in some departments, smaller type. The figures quoted above will we trust serve to explain effectively the conditions which face Canadian publishers, no matter the nature of their medium, and show at same time that the return to normal is quite far removed. A. G. McIntyre, Paper Expert of the Newspaper Publishers Association, estimates that, if the normal paper consumption—6 to 10 per cent. per year in the United States is maintained, and taking as a basis the meantime production of Canadian and American mills, we on this continent will have to face a shortage during 1918

of some 1,500 tons per day. Continuing he states that, "when the price of newsprint dropped to a minimum of 2 cents delivered, a profit of \$10 to \$15 per ton had always been maintained by Canadian mills." Under 1917 contract prices, profits from \$30 per ton upwards are being made." The advantage of the Canadian producer over the American producer, he considers to be considerably in excess of \$5 a ton, and he believes, in view of the current relation of supply to demand, "that the opportunity for Canadian pulp and paper mill development, even under present extreme conditions, is both safe and highly remunerative."

Industrial enterprise, we may say at once, is indissolubly linked with the stock market. In more immediately pre-war days, pulp and paper industries were however rather too lean of appearance to whet the public appetite. Paper-making was then an enterprise engaged in for the benefit of those directly concerned; now, with profits of thirty dollars per ton and upwards, the benefits will accrue for the most part to those with but slight or entire lack of knowledge of even the different plant locations and who care not a "hoot" if they ever know under the circumstances.

The "high cost of living" to which we are all more or less subject has a good excuse in the war, at least so we are made to believe. Our stock and other market manipulators have however more to do with the H.C.L. than has the war, in the final analysis. We are anticipating larger benefits to accrue to us industrially in peace time, both in the matter of meeting our own requirements and those of nations of whose existence we have hitherto had but a hazy geographical knowledge. It is not assuming overmuch when we express the opinion that little in either direction is likely to be realized, unless more attention be given our industries for their value as such, and less as financial footballs.



MORE EFFORT, MORE MEN, MORE MONEY.

IF there is one thing more than another that the recent peace scare has demonstrated, it is the fact of our being in this war to the "knock out" stage. Beyond the confines of the stock market, where expediency, imagination, or reality, stand ever ready either to woo or create opportunity, little excitement and probably still less business dislocation resulted from the now silenced dual-source peace proposals with their "soft pedal" heralding. Renewed and still more forceful expression has been given of the determination of Britain and her Allies to prosecute the war to its logical conclusion, and in this respect the very untimeliness of the peace suggestions have not been without a salutary effect. As we see it, the Dove of Peace—were that the fair bird or another in its borrowed plumes—has tucked its head under its wing for many months to come, under which circumstances, munitions, men, and money, to the limit of our capacity and resources must needs be our New Year programme. Our Imperial Munitions Board, our National Service Commission, and our Patriotic Fund Executive, all war-created organizations, are more intensely than ever war-in-earnest. Coupled with the "Thrift Campaign" now been planned by our Minister of Finance, Sir Thomas White, it is abundantly evident that our efforts and responsibilities are primarily those of war concern, and, therefore, wasted if otherwise directed and evaded. Much is expected of us during the coming year and largely dependent on our measure of response—ourselves and our substance, will the ushering in of a peace worth-while be hastened.

INDUSTRIAL NOTABILITIES

MEURIG LLOYD DAVIES, vice-president, Standard Chemical, Iron, and Lumber Co., of Canada, manufacturers of wood distillation products, Royal Bank Building, Toronto; representative of the United Alkali Co., of Liverpool, England; director, Port Hope Sanitary Manufacturing Co., of Toronto; director, Standard Iron Co., of Montreal; director, North American Chemical Co., Bay City, Mich.; director, Robert Gage Coal Co., Bay City, Mich., was born at Liverpool, England, October 3, 1865, son of William Hamlet Davies and Elizabeth Lloyd (Griffith) Davies, of that city.



MEURIG LLOYD DAVIES.

He was educated at Liverpool College, following which in 1882 he was articled to James Maspratt & Sons, of Liverpool, chemical manufacturers, becoming manager of the works there in 1889. The above firm was absorbed by the United Alkali Co. about a year later. In 1892 he was made manager of the Hutchison Works of the United Alkali Co., at Widnes, Lancashire. From 1899 until 1913 he was resident in the United States, and filled the position of general manager to the North American Chemical Co., Bay City, Mich. In 1913 he came to Toronto as general manager of the Standard Chemical, Iron, and Lumber Co., being made vice-president in the same year.

Mr. Davies married Sarah Elizabeth Simister, daughter of Timothy Simister, Runcorn, England, August 23, 1893, the family consisting of two daughters. His clubs are: Toronto, Albany, Rosedale Golf and R.C.Y.C.; his societies: A.F. & A.M. (32^d Scottish Rite); Society of Chemical Industry (Canadian Section); St. George's Society. In politics, he is Conservative, and in religious creed, Anglican. His residence is 31 South Drive, Toronto, Ont.

—Photo courtesy British and Colonial Press.

SELECTED MARKET QUOTATIONS

Being a record of prices current on raw and finished material entering into the manufacture of mechanical and general engineering products.

PIG IRON.

Grey forge, Pittsburgh ..	\$29 95
Lake Superior, charcoal,	
Chicago ..	31 75
Standard low phos., Phila-	
delphia ..	53 00
Bessemer, Pittsburgh ..	35 95
Basic, Valley furnace ..	30 00
Montreal Toronto	
Middlesboro, No. 3 ..	
Cleveland, No. 3 ..	
Clarence, No. 3 ..	
Hamilton ..	
Victoria ..	40 00 38 00

FINISHED IRON AND STEEL.

Per lb. to Large Buyers. Cents

Iron bars, base, Toronto ..	3.50
Steel bars, base, Toronto ..	3.75
Steel bars, 2 in. and larger	
base ..	3.25
Iron bars, base, Montreal ..	3.55
Steel bars, base, Montreal ..	3.80
Twisted reinforcing bars,	
base ..	3.55
Bessemer rails, heavy, at	
mill ..	
Steel bars, Pittsburgh ..	
Tank plates, Pittsburgh ..	
Beams and angles, Pitts-	
burgh ..	
Steel hoops, Pittsburgh ..	
F.O.B., Toronto Warehouse.	
Cents	
Steel bars, base ..	3.75
Small shapes ..	4.00
F.O.B. Chicago Warehouse	
Cents	
Steel bars ..	3.75
2 in. and up ..	4.25
Structural shapes ..	3.85
Plates ..	4.50

FREIGHT RATES.

Pittsburgh to Following	Points
	Per 100 lbs.
	C.L. L.C.L.
Montreal ..	23.1 31.5
St. John, N.B. ..	35.1 45.5
Halifax ..	35.1 45.5
Toronto ..	18.9 22.1
Guelph ..	18.9 22.1
London ..	18.9 22.1
Windsor ..	18.9 22.1
Winnipeg ..	64.9 85.1

METALS.

Montreal Toronto

Lake copper, car-	load	\$36 00	\$36 00
Electrolytic cop-	per	36 00	36 00
Castings, copper,		35 00	36 00
Tin ..		47 00	47 00
Spelter ..		13 50	13 50
Lead ..		10 00	9 50
Antimony ..		15 00	18 00
Aluminum ..		70 00	68 00

BOILER PLATES.

Montreal Toronto

Plates, 1/4 to 1/2 ..	\$5 40	\$5 40
Heads ..	5 75	5 75
Tank plates, 3-16 in.	5 50	5 50

WROUGHT PIPE.

Buttweld.

Prices in effect Dec. 30, 1916.

Per 100 feet Black-Galv.

1/8 in.	\$ 4 25	\$ 5 75
1/4 in.	3 54	5 07
3/8 in.	3 54	5 07
1/2 in.	4 59	6 16
3/4 in.	5 64	7 76
1 in.	8 35	11 48
1 1/4 in.	11 27	15 53
1 1/2 in.	13 48	18 56
2 in.	18 13	24 98
2 1/2 in.	28 67	39 49
3 in.	37 49	51 64
3 1/2 in.	46 92	63 94
4 in.	55 59	75 76

Lapweld.

2 in.	21 09	27 57
2 1/2 in.	31 59	41 83
3 in.	41 31	54 70

3 1/2 in.	51 52	68 54
4 in.	61 04	81 21
4 1/2 in.	71 12	94 62
5 in.	82 88	110 30
6 in.	107 50	143 00
7 in.	142 80	186 80
8 in.	150 00	196 30
8 in.	172 80	226 70
9 in.	207 00	270 80
10 in.	192 00	251 20
10 in.	217 20	323 40

Prices Ontario, Quebec and Maritime Provinces.

WROUGHT NIPPLES.

4" and under, 60%.	
4 1/2" and larger, 55%.	
4" and under, running thread, 40%.	
Standard couplings, 4" and under, 50%.	
4 1/2" and larger, 30%.	

OLD MATERIAL.

Dealers' Buying prices.

	Montreal	Toronto
Copper, light ..	\$19 00	\$21 75
Copper, crucible ..	23 00	25 25
Copper, heavy ..	23 00	24 50
Copper wire ..	23 00	24 50
No. 1 machine		
composition ..	20 50	19 50
No. 1 composition		
turnings ..	16 50	17 00
New Brass clip-		
pings ..	17 00	17 00
No. 1 brass turn-		
ings ..	15 25	15 00
Steel, low phos. ..	14 00	14 00
Heavy Melting		
steel ..	13 00	14 00
No. 1 machine		
cast iron ..	20 00	16 00
Steel turnings ..	7 00	7 00
Boiler plate ..	12 00	16 50
Rails ..	14 75	15 00
Axles, wrought		
iron ..	19 00	24 00
Tires, steel ..	12 00	11 00
Rails ..	13 75	14 00
Shafting ..	20 00	20 00
Malleable scrap ..	10 25	11 00
Pipe, wrought ..	10 50	9 00
Stove plate ..	13 00	13 00
Heavy lead ..	7 50	7 75
Tea lead ..	6 00	5 50
Scrap zinc ..	8 00	7 00
Aluminum ..	35 00	35 00

BOLTS, NUTS AND SCREWS.

Per Cent.

Coach and lag screws ..	35
Stove bolts ..	55
Plate washers ..	20
Machine bolts, 7-16 and	
over ..	15
Machine bolts, 3/8 and less.	25
Blank bolts ..	15
Bolt ends ..	15
Machine screws, fl. and rd.	
hd., steel ..	27 1/2
Machine screws, o. and fl.	
hd., steel ..	10
Machine screws, fl. and rd.	
hd., brass ..	add 20
Machine screws, o. and fl.	
hd., brass ..	add 25
Nuts, hex., up to 1 in., \$3.75	
per lb. off.	
Nuts, hex., over 1 in., \$2.00	
per lb. off.	
Copper rivets and burrs,	
list plus ..	30
Burrs only list plus ..	50
Iron rivets and burrs ..	30
Boiler rivets, base 3/4-in.	
and larger ..	\$5 25
Structural rivets, as above	5 15
Wood screws, flat, bright ..	75
Wood screws, O. & R.,	
bright ..	70
Wood screws, flat, brass ..	42 1/2
Wood screws, O. & R.,	
brass ..	40
Wood screws, flat, bronze.	35
Wood screws, O. & R.,	
bronze ..	22 1/2

MILLED PRODUCTS.

Per Cent.

Set screws ..	40
Sq. & Hex. Head Cap Screws	30
Rd. & Fil Head Cap Screws.	15
Flat & But. Hd. Cap Screws	
plus ..	15
Fin. & semi-fin, nuts up to	
1 in.	30
Fin. and semi-fin, nuts,	
over 1 in.	25
Studs ..	15
Taper pins ..	45
Coupling bolts, plus ..	15
Planer head bolts, without	
fillet ..	15
Planer head bolts, with fillet, net	
Planer head bolt nuts, up to	
1 in.	30
Planer head bolt nuts, over	
1 in.	25
Planer bolt washers ..	10
Hollow set screws ..	40
Collar screws ..	20
Thumb screws ..	20
Thumb nuts ..	70
Patch bolts ..	add 65
Cold pressed nuts to 1 1/2	
in.	add 3.50
Cold pressed nuts over 1 1/2	
in.	add \$2.00

BILLETS.

Per gross ton

Bessemer billets ..	\$60 00
Open-heart billets ..	60 00
O.H. sheet bars ..	60 00
Forging billets ..	80 00
Wire rods ..	70 00
F.o.b. Pittsburgh.	

NAILS AND SPIKES.

Wire nails ..	4 75	4 70
Cut nails ..	4 00	4 00
Miscellaneous wire nails ..	65%	
Pressed spikes, 3/8 diam.,		
100 lbs.	\$4 10	

MISCELLANEOUS.

Solder, guaranteed ..	0 28 1/2
Solder, strictly ..	0 25 1/2
Babbitt metals ..	11 to 60
Soldering coppers, lb.	0 53
Putty, 100-lb. drums ..	3 00
White lead, pure, cwt.	14 25
Red dry lead, 100-lb. kegs,	
per cwt.	13 87
Gine, French medal, lb.	0 25
Tarred slaters' paper, roll	0 85
Gasoline, per gal., bulk ..	0 27 1/2
Benzine, per gal., bulk ..	0 26 1/2
Pure turpentine, single	
bbls., gal.	0 71
Linseed oil, raw, single,	
bbls.	1 12
Linseed oil, boiled, single	
bbls.	1 15
Plaster of Paris, per bbl. ..	2 50
Plumbers' oakum, per cwt.	8 00
Packing, square braided ..	0 27
Packing, No. 1 Italian ..	0 25
Packing, No. 2 Italian ..	0 25
Lead wool, per lb.	0 12
Pure Manila rope ..	0 25 1/2
Transmission rope, Manila	0 29 1/2
Drilling cables, Manila ..	0 28 1/2

POLISHED DRILL ROD.

Discount off list, Montreal and Toronto .. 25%

CARBON DRILLS AND REAMERS.

Per Cent.

S.S. drills, wire sizes ..	35
S.S. drills, 1/16 in. and larger	50
Standard drills to 1 1/2 in.	50
Standard drills, over 1 1/2 in.	20
3-fluted drills to 1 1/2 in.	20
3-fluted drills, over 1 1/2 in.	10
Bit stock ..	50
Ratchet drills ..	20
Machine bits for wood ..	15
S.S. drills for wood ..	45
Wood boring brace drills ..	35
Electricians ..	25
Sockets ..	30

Sleeves ..	40
Taper pin and taper reamers	30
"Premier" and "Leader"	
chucks ..	10
Arbors for above ..	net
Drills and counterstinks ..	list plus 30
Bridge reamers ..	55
Centre reamers ..	10
Chucking reamers ..	10
Hand reamers ..	15
High-speed drills up to 1 1/2 in.	
and over 1 1/2 in. are now double	
list.	

COLD ROLLED SHAFTING.

At mill .. list plus 40%

At warehouse .. list plus 50%

Discounts off new list. Warehouse price at Montreal and Toronto.

IRON PIPE FITTINGS.

Canadian malleable, A, add 5%; B and C, 12%; cast iron, 40; standard bushings, 50%; headers, 60; flanged unions, 45; malleable bushings, 50; nipples, 70; malleable lipped unions, 55.

SHEETS.

Montreal Toronto

Sheets, Black, No. 28, \$5 00	\$5 75
Sheets, Black, No. 10, 5 50	5 60
Canada plates, dull,	
52 sheets ..	5 75 5 75
Canada plates, all	
bright ..	6 50 6 50
Apollo brand, 10% oz.	
galvanized ..	7 25 7 25
Queen's Head, 28 B.	
W.G.	7 75 7 75
Fleur-de-Lis, 28 B.W.	
G.	7 45 7 35
Gorbals Best, No. 28	8 25 7 50
Colborne Crown, No.	
28 ..	8 00 6 75
Premier, No. 28 U.S.	6 70 7 20
Premier, 10% oz.	7 00 7 50

PROOF COIL CHAIN.

1/4 in.	\$9 45
5-16 in.	9 10
3/8 in.	8 35
7-16 in.	7 15
1/2 in.	6 95
9-16 in.	6 95
5/8 in.	6 80
3/4 in.	6 70
7/8 in.	6 55
1 inch ..	6 40

Above quotations are per cwt.

ELECTRIC WELD COIL CHAIN B.B.

1/4 in.	\$15 50
3-16 in.	11 70
1/4 in.	8 40
5-16 in.	7 40
3/8 in.	6 35
7-16 in.	6 35
1/2 in.	6 25
5/8 in.	6 25
3/4 in.	6 25

Prices per 100 lbs.

FILES AND RASPS.

Per Cent.

Great Western, American ..	60
Kearney & Foot, Arcade ..	60
J. Barton Smith, Eagle ..	60
McClelland, Globe ..	60
Black Diamond ..	50
Delta Files ..	47 1/2
Nicholson ..	50
Globe ..	57 1/2
Vulcan ..	57 1/2
Disston ..	60

COAL AND COKE.

Solvay Foundry Coke ..	
Cornellsville Foundry Coke ..	
Yough Steam Lump Coal ..	8 50
Pittsburgh Steam Lump Coal	8 50
Best Slack ..	9 00
Net ton f.o.b. Toronto	

BOILER TUBES.

Size.	Seam-less	Lap-welded
1 in.	\$30 00	
1 1/4 in.	30 00	
1 1/2 in.	30 00	24 00
1 3/4 in.	29 00	21 00
2 in.	33 00	20 00
2 1/4 in.	33 00	
2 1/2 in.	35 75	26 50
3 in.	55 00	31 00
3 1/4 in.	54 50	36 00
3 1/2 in.	59 50	39 00
4 in.	75 00	49 00

Prices per 100 feet, Montreal and Toronto.

OILS AND COMPOUNDS.

Castor oil, per lb.	25
Royalite, per gal., bulk.	12
Machine oil, per gal.	25 1/2
Black oil, per gal.	12 1/2
Cylinder oil, Capital.	45 1/2
Cylinder oil, Aeme.	36 1/2
Standard cutting compound, per lb.	0.6
Lard oil, per gal.	1 45
Union thread cutting oil antiseptic.	68
Aeme cutting oil, antiseptic.	37 1/2
Imperial quenching oil.	39 1/2
Petroleum fuel oil.	10 3/4

BELTING—NO. 1 OAK TANNED.

Extra heavy, single and double.	30-10%
Standard.	40%
Cut leather lacing, No. 1.	\$1 40
Leather in sides.	1 20

TAPES.

Chesterman Metallic, 50 ft.	\$2 00
Lufkin Metallic, 603, 50 ft.	2 00
Admiral Steel Tape, 50 ft.	2 75
Admiral Steel Tape, 100 ft.	4 45
Major Jun. Steel Tape, 50 ft.	3 50
Rival Steel Tape, 50 ft.	2 75
Rival Steel Tape, 100 ft.	4 45
Reliable Jun. Steel Tape, 50 ft.	3 50

WASTE.

White	Cents per lb.
XXX Extra	18
Peerless	18
Grand	17
Superior	17
N L C R	16
Atlas	16
X Empire	15
Ideal	15
X press	14

COLORED.

Lion	12 1/2
Standard	11
No. 1	11
Popular	10
Keen	90

WOOL PACKING.

Arrow	24
Axle	18
Anvil	14
Anchor	11

WASHED WIPERS.

Select White	12
Mixed colored	10
Dark colored	90

This list subject to trade discount for quantity.

RUBBER BELTING.

Standard	50%
Best grades	30%

ANODES.

Nickel	.50 to .54
Cobalt	1.75 to 2.00
Copper	.44 to .46
Tin	.49 to .56
Zinc	.23 to .25

Prices Per Lb.

COPPER SHEETS.

Montreal Toronto	
Bars, 1/2 to 2 in.	\$46 00 \$46 00
Plain sheets, 14 oz., 14x28 in., 14x60 in.	45 00 45 00
Copper sheet, tinned, 14x60, 14 oz.	54 00 54 00
Copper sheet, plain, 14x60 base.	57 00 57 00
Braziers' in sheets, 6x4 base.	46 50 46 50

BRASS.

Brass rods, base 1/2 in. to 1 in. rd.	0 55
Brass sheets, 8 in. wide, 20 oz.	0 60
Brass tubing, seamless.	0 55
Copper tubing, seamless.	0 55

PLATING SUPPLIES.

Polishing wheels, felt.	2 10
Polishing wheels, bull-neck.	1 35
Emery in kegs, American.	06
Pumice, ground.	04
Emery glue.	15 to 20
Tripoli composition.	04 to 06
Crocus composition.	07 to 08
Emery composition.	08 to 09
Rouge, silver.	35 to 50
Rouge, powder.	30 to 35

Prices Per Lb.

LEAD SHEETS.

Montreal Toronto	
Sheets, 3 lbs. sq. ft.	\$12 00 \$12 50
Sheets, 3 1/2 lbs. sq.	

ft.	11 75	12 25
Sheets, 4 to 6 lbs. sq. ft.	11 50	12 00
Cut sheets, 1/2c per lb. extra.		
Cut sheets to size, 1c per lb. extra.		

PLATING CHEMICALS.

Acid, boracic	\$.15
Acid, hydrochloric	.05
Acid, hydrofluoric	.14 1/2
Acid, nitric	.19
Acid, sulphuric	.05
Ammonia, aqua	.08
Ammonium carbonate	.15
Ammonium chloride	.11
Ammonium hydrosulphuret	.40
Ammonium sulphate	.07
Arsenic, white	.12
Copper, carbonate, anhy.	.35
Copper, sulphate	.17
Cobalt sulphate	.70
Iron perchloride	.20
Lead acetate	.16
Nickel ammonium sulphate	.12
Nickel carbonate	.35
Nickel sulphate	.15
Potassium carbonate	.75
Potassium sulphide (substituted)	.20
Silver chloride (per oz.)	.65
Silver nitrate (per oz.)	.55
Sodium bisulphite	.10
Sodium carbonate crystals	.05
Sodium cyanide, 127-1300	.41
Sodium hydrate	.04
Sodium hyposulphite, per 100 lbs.	5.00
Sodium phosphate	.14
Tin chloride	.60
Zinc chloride	.60
Zinc sulphate	.09

Prices Per Lb. Unless Otherwise Stated.

The General Market Conditions and Tendencies

This section sets forth the views and observations of men qualified to judge the outlook and with whom we are in close touch through provincial correspondents

Montreal, Que., Jan. 8, 1917.—With the turn of the year, commercial and industrial interests have resumed their pre-holiday activity. The business outlook for the ensuing twelve months equals, if not surpasses, that of the like period just closed. More or less relief has been recently afforded transportation difficulties by reason of additional rolling stock having been made available.

Pig Iron

The production of pig iron is being affected by the marked scarcity of coke, together with the trouble experienced in delivery of the raw materials to the furnaces. The coke situation has recently been of such a serious nature as to cause the temporary or partial shut down of several blast furnaces. No price advances have taken place during the week, but the high level reached a couple of weeks ago is being maintained. It is generally conceded, however, that the crest of the advance has been reached.

Steel

The steel situation has failed to resume its pre-holiday activity, the present market being exceptionally quiet. In addition to the adjustments that are habitual at this period of the year, the quiet tone noticeable is no doubt due to the uncertainty still prevailing in some quarters

as to the ultimate outcome of international peace negotiations. Production continues unabated with prices at the high level. Blue annealed sheets have been advanced \$10 per ton, the Pittsburgh quotation being \$4.50 per hundred. Black sheets are lower, the base being \$5 per hundred. Local prices on sheets show a tendency to advance. Dealers here have recently revised their quotations on boiler plates and tubes; plates are now \$5.40; heads, \$5.75 and tank plates (3-16 in. thick) are \$5.50. Changes in tube prices effect the 3 and 4 inch seamless sizes, the demand for these being very heavy. The former are now \$55, and the latter \$75 per 100 feet.

High Speed Steel

The situation in high speed steel shows little change. The demand continues heavy and prices are very firm, ranging from \$2.50 to \$3 per pound.

Metals

The market appears still affected by peace talk. Copper shows a weaker tendency. Tin is slightly stronger and temporarily higher. Spelter is firm and steady. Lead continues very firm, with slight scarcity apparent.

Copper.—The market is still influenced by the uncertainty that still prevails regarding the present political situation.

Activity in resale metal has apparently weakened the market, but producers continue to quote high prices. The market has declined both in London and New York; the latter now quoting 29 cents for lake and 28 1/4 cents for electrolytic. The situation here is quiet, but dealers are firm in their quotations; lake and electrolytic being 36 cents, and castings 35 cents per pound.

Tin.—Strength was given the market following a little increased activity during the latter part of the week. The general situation, however, is without material change. Advances are noted in both London and New York reports; New York being 1 1/4 cents higher than a week ago. Dealers here are quoting 17 cents on a steady market, this being an advance of one cent per pound.

Spelter.—Satisfactory conditions prevail in the spelter market, producers are holding firm on prices. The abnormal production which appeared evident some months ago has not materialized, as the additional facilities have been offset by the closing of a number of mines. The local situation continues steady with prices firm at 13 1/2 cents per pound.

Lead. The market in lead continues very firm in face of recent and current disturbances. This is partly due to an apparent scarcity of available metal. New York is still quoting 7 1/2 cents for "trust" metal, with "independents" asking 1/2 cent higher. Prices here are unchanged at 10 cents per pound.

Antimony. The market is holding firm, prices being well maintained. Dealers here are quoting 15 cents per pound on a quiet market.

Aluminum.—The market is very steady, the quotation here having returned to 70 cents per pound.

Machine Tools and Supplies

With the passing of the holiday season the machine tool trade is again resuming some of its previous activity. The recent placing of large munition contracts is beginning to reflect itself in the demand for additional equipment. The abnormal high cost of raw materials and labor has resulted in higher prices for all lines of tools. The expense entailed in equipping a plant at the present time is from 50 to 75 per cent. greater than that of a couple of years ago.

Scrap

Following a quiet week in the scrap market the general tone is easier, more especially in old copper. Much of the inactivity is owing to the difficulty of securing shipping facilities, although the demand has also fallen off. The local changes this week are a decline of 2 cents on old copper, the current quotations ranging from 19 cents for light, to 23 cents for heavy and old wire. Owing to the curtailment in pig iron production the demand on machine cast iron has increased, an advance of 5 cents per hundred, placing this class of scrap on a \$20 per ton basis. Old shafting is much in demand, the price quoted being 20 cents, an advance of 3¼ cents. Stove plate is higher, the local notation of 13 cents being one cent over that of last week.

Toronto, Ont., Jan. 9.—The freight situation is perhaps the outstanding feature in industrial circles this week. Conditions have been steadily getting worse for some months, until now a crisis has been reached. This is particularly so as regards coal, due largely to the shortage of motive power and cars, and also congestion in the freight yards. It is proposed to take off a number of passenger trains between Toronto and the U. S. border, so as to release engines for hauling freight trains.

Steel

The peace proposals have had less effect on the steel market than was anticipated, prices still advancing. How long this upward movement will continue is difficult to say, but in any case some products will be affected more than others. Take, for instance, ship plates and steel rails, for which there will be as big a demand after the war as there is at the present time; prices on these, particularly the former, will yet reach a considerably higher level, and the relative advance in plates will be greater than in bars and shapes. Plates have advanced 40c per 100 lbs. since the beginning of the year, ¼-in. and larger being now quoted at \$5.40; heads, \$5.70; and tank plates, \$5.50 per 100 lbs. Local warehouse price on steel bars is now 3.75c, and, on small shapes, 4c per lb. Wrought iron pipe, black and galvanized, has advanced 2 points, while higher prices on black sheets have been announced. This advance in sheets has been expected, as

the situation in the primary market is tight, due to shortage of sheet bars and scarcity of fuel and labor. Deliveries are getting very backward on account of conditions at the mills, and indications point to further advances. Galvanized sheets are unchanged in the meantime, the weakness in spelter having some effect on the market. Local steel merchants report a good volume of business during December, and believe that January will be even better. Deliveries from mills continue slow, with no sign of improvement. Local shipbuilders are asking for considerable tonnages of steel plates, but are experiencing much difficulty in getting this material, even at the fancy prices now ruling. The scarcity of ship plates is restricting development in the shipbuilding industry.

While the steel market in the U. S. is less active than it was before the peace proposals were made, there is little sign of weakness. As a matter of fact, prices are being well maintained, which emphasizes the strong technical position of the market. Foreign demand continues, despite the existence of peace talk and uncertainty in the international situation. Chicago warehouse prices are higher, bars being quoted at 3.75c; bars, 2 in. and up, 4.25c; structural shapes, 3.85c; and plates, 4.50c per lb. Bessemer and open-hearth billets are now being quoted at \$60 per ton, Pittsburgh.

Pig Iron

There is no change in the pig iron situation, the general tone of the market being strong, though quiet. Prices of domestic pig irons are still withdrawn. In the U. S., the pig iron market is quiet. Buyers continue to wait for developments in international affairs before proceeding with the covering of requirements over the second half of the year. Prices continue firm, but unchanged.

Coal and Coke

The situation in coal and coke is getting more acute, and there appears to be little possibility of any pronounced relief until the spring. Shortage of motive power and congestion of freight in the railway yards are the principal causes, but efforts are being made to relieve the situation. Coal dealers warn consumers not to buy more coal than they really require, otherwise the shortage will become more serious. Prices are higher, steam coal is selling at \$8.50, and best slack at \$9 f.o.b. cars. Prices on coke are unobtainable.

Scrap

The scrap market is very unsettled, due to peace talk and freight congestion on the railways. Prices on all grades of copper and brass scrap have declined approximately 2c per pound, but steel scrap has not been affected. The embargo which was placed on the export of steel turnings has been extended to include all grades of steel scrap; this is having a tendency to weaken the market on same. The demand for scrap generally is good, notwithstanding the unsettled situation.

Machine Tools

The market continues quiet, with no

developments of particular interest to note. The prospect of further large orders for munitions being placed in Canada instead of in the U. S. has improved the outlook, and a large volume of business is expected. Another credit of \$50,000,000 has been arranged by the Canadian banks for the British Government to finance further contracts for munitions.

Supplies

Prices on machine shop supplies are still advancing. New and higher prices on lubricating and machine oils have been announced. These oils will in the future be sold on a bulk basis, while an extra charge of \$2 will be made for the barrels. The prices given in the selected market quotations have been revised accordingly. Castor oil is higher, and is now quoted at 25c. Lard oil has also advanced and is now \$1.45. Acme cutting oil, Union thread cutting oil, and fuel oil prices have also been revised upwards. New discounts have been issued on brass machine screws, but iron screws are unchanged. Packings have been advanced 2c. per pound.

Metals

The metal markets are still being influenced by peace talk and the situation is consequently somewhat unsettled. Copper has declined, otherwise prices are unchanged locally. Business which was quiet over the holidays is improving, and a renewal of former activity is anticipated.

Copper.—Although copper has declined on account of peace talk, the position of this metal is still very strong, and a recovery is more than likely. The consumption of copper will be very heavy even after the war, which will have a tendency to keep prices up. Locally copper has declined 2c. and quotations are entirely nominal at 36c per pound.

Tin.—The market is steadier with a fair volume of business. Quotations are unchanged and nominal at 48c. per pound.

Spelter.—The situation is unchanged and the market has a quiet tone. Local quotations steady at 13½c. per pound.

Lead.—The market is characterized by a general tone of dullness. The leading interest maintains its price at 7.50c. New York, but the outside interests are understood to be selling below that figure. Local price 9½c. per pound.

Antimony.—The market generally is featureless, with quotations unchanged at 18c. per pound.

Aluminum.—Quotations are firm but nominal at 68c. per pound.

Solders.—There has been a decline in prices of solders. Guaranteed is now quoted at 28½c., and strictly at 25½c. per pound.



BIG CONTRACT ABANDONED

THE seven million dollar contract for the improvement of the port of St. John (Courtenay Bay side) has been thrown up by the contractors, the Norton, Griffiths Co., and all work discontinued.

The St. John harbor works were part of the general scheme of the present Government for the improvement of

Canadian ocean ports. A good deal of work has been done, but the contractors, who were to have completed the larger part of the improvements by next spring have not made the necessary progress and are now apparently unable to go on. In addition to the actual harbor work, the plans included the construction of a large drydock on a subsidy basis.

It is regarded as unlikely that the Public Works Department will take over the uncompleted work. If the completion is not to be deferred until after the war, the contract will probably be transferred. Something like \$3,000,000 has already been expended on undertaking.

MANUFACTURING PATRIOTISM

SOME time ago the Imperial Munitions Board at Ottawa found themselves facing a 75 per cent. increase in the already high prices of acetone supplied from the United States. They decided upon its manufacture in Canada. After full investigation, it was reported to the board that the distillery at Toronto, of Messrs. Gooderham & Worts, was the most suitable of all the Canadian distilleries for the purpose. The Munitions Board thereupon offered to lease the building and plant from the company for the duration of the war; the rental to be based on the average net profits of Messrs. Gooderham & Worts, for the past three years, plus interest on their actual investment. The company within a few days thereafter refused the offer of the Munitions Board. In effect, the whisky distillers said:

"This company will lease its distillery, its buildings and its complete plant to the Board only upon the understanding that it shall receive no compensation whatever from the Imperial Munitions Board. Furthermore, we are authorized to say that if the services of our general manager, Col. H. E. Gooderham, and his son, Capt. Gooderham, are of any use to the Board in the operation of the company's plant thereafter, they are offered on like terms."

Needless to say, the offer was promptly and gratefully accepted as a result, and the Board is now operating the Gooderham & Worts plant, with Col. Gooderham as general manager, and Captain Gooderham as assistant general manager, paying nothing for either plant or managers. The Imperial Government has asked the Munitions Board to convey to Messrs. Gooderham & Worts its thanks for their munificent and patriotic action.

Trail, B.C.—The Consolidated Mining & Smelting Co., is preparing plans for enlarged operations in the refining of copper with a 50 per cent. increase to its present facilities. With such increase effected, the refinery will have capacity for producing about 11,000,000 pounds of refined copper per annum. There is no other copper refinery in Canada at the present time. The Consolidated Mining Co., was a pioneer in the treatment of zinc electrolytically, and, from the resultant production a new source of income was developed the past year.

Enlarged Canadian Trade Intelligence Service

Under the arrangement made by the Minister of Trade and Commerce with Sir Edward Grey in July, 1912, the Department of Trade and Commerce, Ottawa, is able to present the following list of the more important British Consulates whose officers have been instructed by the Foreign Office to answer inquiries from and give information to Canadians who wish to consult them in reference to trade matters.

BRAZIL—Bahia, British Consul. Rio de Janeiro, British Consul General.	NETHERLANDS—Amsterdam, British Consul.
CHILE—Valparaiso, British Consul General.	PANAMA—Colon, British Consul. Panama, British Vice-Consul.
COLOMBIA—Bogota, British Consul General.	PERU—Lima, British Vice-Consul.
ECUADOR—Quito, British Consul General. Guayaquil, British Consul.	PORTUGAL—Lisbon, British Consul.
EGYPT—Alexandria, British Consul General.	RUSSIA—Moscow, British Consul General. Petrograd, British Consul. Vladivostok, British Consul. Odessa, British Consul General.
FRANCE—Havre, British Consul General. Marseilles, British Consul General.	SPAIN—Barcelona, British Consul General. Madrid, British Consul.
INDIA—Calcutta, Director General of Commercial Intelligence.	SWEDEN—Stockholm, British Consul.
ITALY—Genoa, British Consul General. Milan, British Consul.	SWITZERLAND—Geneva, British Consul.
MEXICO—Mexico, British Consul General.	URUGUAY—Monte Video, British Vice-Consul.
	VENEZUELA—Caracas, British Vice-Consul.

Canadian Commercial Intelligence Service

The Department of Trade and Commerce invites correspondence from Canadian exporters or importers upon all trade matters. Canadian Trade Commissioners and Commercial Agents should be kept supplied with catalogues, price lists, discount rates, etc., and the names and addresses of trade representatives by Canadian exporters. Catalogues should state whether prices are at factory point, f.o.b. at port of shipment, or, which is preferable, c.i.f. at foreign port.

CANADIAN TRADE COMMISSIONERS.

ARGENTINE REPUBLIC—H. R. Poussette, Reconquista, No. 46, Buenos Aires. Cable address, Canadian.
AUSTRALIA—D. H. Ross, Stock Exchange Building, Melbourne. Cable address, Canadian.
BRITISH WEST INDIES—E. H. S. Flood, Bridgetown, Barbadoes, agent also for the Bermudas and British Guiana. Cable address, Canadian.
CHINA—J. W. Ross, 13 Nanking Road, Shanghai. Cable address, Canada.
CUBA—Acting Trade Commissioner, Louja del Comercio, Apartado 1290, Havana. Cable address, Cantracoom.
FRANCE—Phillipe Roy, Commissioner General, 17 and 19 Boulevard des Capucines, Paris. Cable address, Canada.
JAPAN—G. B. Johnson, P. O. Box 109, Yokohama. Cable address, Canadian.
HOLLAND—Acting Trade Commissioner, Zuidblaak, 26, Rotterdam. Cable address, Watermill.
RUSSIA—C. F. Just, Canadian Government Commercial Agent, Alexandriyskaya, Ploshch 9, Petrograd. E. D. Wilgress, Canadian Government Commercial Agent, Bukhholza Ulitsa No. 4, Omsk, Siberia.
NEWFOUNDLAND—W. B. Nicholson, Bank of Montreal Building, Water Street, St. John's. Cable address, Canadian.
NEW ZEALAND—W. A. Beddoe, Union Buildings, Customs Street, Auckland. Cable address, Canadian.
SOUTH AFRICA—W. J. Egan, Norwich Union Buildings, Cape Town. Cable address, Cantracoom.
UNITED KINGDOM—Harrison Watson, 73 Basinghall Street, London, E.C., England. Cable address, Sleighing, London. N. D. Johnston, Sun Building, Clare Street, Bristol. Cable address, Canadian. J. E. Ray, Central House, Birmingham. Cable address, Canadian. J. Forsyth Smith, 27-28 Pearl Building, East Parade, Leeds. Cable address, Canadian. F. A. C. Bickerlke, Canada Chambers, 36 Spring Gardens, Manchester. Cable address, Cantracoom. J. T. Lithgow, 87 Union Street, Glasgow, Scotland. Cable address, Cantracoom.

SPECIAL TRADE COMMISSIONER—LUMBER

H. E. McMillan, visiting Europe, Africa, Australasia and the Orient.

CANADIAN COMMERCIAL AGENTS

AUSTRALIA—B. Millin, Exchange Building, Sydney, N.S.W.
BRITISH WEST INDIES—Edgar Tripp, Port of Spain, Trinidad. Cable address, Canadian. R. H. Curry, Nassau, Bahamas.
NORWAY AND DENMARK—C. E. Soutum Grubbeged No. 4, Christiana, Norway. Cable address, Soutum.

CANADIAN HIGH COMMISSIONER'S OFFICE

UNITED KINGDOM—W. L. Griffith, Secretary, 17 Victoria Street, London, S.W., England. Cable address, Donlinen, London.

INDUSTRIAL ^A_N^D CONSTRUCTION NEWS

Establishment or Enlargement of Factories, Mills, Power Plants, Etc.; Construction of Railways, Bridges, Etc.; Municipal Undertakings; Mining News

ENGINEERING

St. Catharines, Ont.—The Kinleith Paper Co. will build an extension to their mill here.

Toronto, Ont.—It is reported that a large steel plant may be established here under the Imperial Munitions Board.

Thorold, Ont.—The Exolon Co., manufacturer of abrasive wheels, has awarded the contract for an addition to its plant. Estimated cost, \$100,000.

Timmins, Ont.—The Murray Mogridge Mining Co., proposes to build a compressor plant and stamp mill on property near here. Engineer, C. E. Jury, Toronto.

Brandon, Man.—Fire recently destroyed the Brandon Machine & Implement Works, the damage being estimated at \$20,000, which is partly covered by insurance.

Toronto, Ont.—City Architect Pearse has issued a permit for a 20,000-gallon water tank to Adams Bros., on King Street, near Niagara. The tank will cost \$1,240.

Vancouver, B.C.—Fire which started on Jan. 5 in Wood, Vallance & Leggatt's paint warehouse, caused a loss of over half a million dollars, fully covered by insurance.

Preston, Ont.—Fire here on Jan. 7 destroyed the blacksmith and finishing shops of the Preston Car and Coach Co. The origin of the fire is not known. The loss is estimated at about \$100,000.

Galt, Ont.—Damage to the extent of \$35,000 was done by fire on Jan. 3 to the factory of the Crown Hat Co. All machinery in the stitching-room was destroyed. The loss is fairly well covered by insurance.

Port Arthur, Ont.—The Port Arthur Copper Co., which was recently incorporated at Toronto, propose to build a concentrating plant in this district. F. M. Connell, mining engineer, Toronto, is interested in the concern.

ELECTRICAL

Weston, Ont.—At the elections on Jan. 1, the hydro by-law was carried by a large majority.

MUNICIPAL

St. Marys, Ont.—The Town Council contemplate installing a sewage disposal plant.

Midland, Ont.—The Hydro-electric by-law carried here by a majority of 55 on Jan. 1.

Strathroy, Ont.—The ratepayers on Jan. 1 carried a by-law endorsing the hydro plebiscite.

London, Ont.—It is proposed to utilize 22 acres of city property on Egerton Street for factory sites.

Cochrane, Ont.—A by-law for a \$10,000 loan was carried at the recent elections, also a by-law re rate of taxes.

Oil Springs, Ont.—Ratepayers on Jan. 1, strongly endorsed the by-law enabling the Council to spend \$10,000 on installing hydro.

Port Dover, Ont.—The ratepayers on Jan. 1, granted fixed assessment to the Ivey Greenhouse Co., figures on the vote being: For, 156; against, 31.

Highgate, Ont.—The ratepayers on Jan. 1, carried by a majority of 69 the enabling by-law authorizing the installation of hydro. The figures were: For, 75; against, 6.

CANADIAN GOVERNMENT PURCHASING COMMISSION

The following gentlemen constitute the Commission appointed to make all purchases under the Dominion \$100,000,000 war appropriation:—George F. Galt, Winnipeg; Hormidas Laporte, Montreal; A. E. Kemp, Toronto. Thomas Hilliard is secretary, and the Commission headquarters are at Ottawa.

Markham, Ont.—By a vote of 96 to 8 the ratepayers on Jan. 1, endorsed the proposition to expend the sum of \$6,000 on the extension of the present waterworks system.

New Toronto, Ont.—The by-law has been carried fixing the assessment at \$4,000 per acre on property, etc., of Brown's Copper & Brass Rolling Mills, Ltd. The company is making important extensions to the plant.

Listowel, Ont.—A by-law to expend \$20,000 on public and high school improvements, was carried by the narrow margin of 41. A second by-law, providing for an expenditure of \$18,000 on street paving, was defeated by 187 majority.

Sarnia, Ont.—The flow of water from the new basins placed in operation at the new waterworks at Point Edward has shown an output of half-million gallons in 24 hours. This is not as large a flow as was looked for as these basins are right on the bank of the river. It is expected that the city will put down more basins, as the plan is declared to be a good one, and all that is needed is enough basins to give the required amount of water.

CONTRACTS

Vancouver, B.C.—A large piling contract has been awarded by the C. P. R. to the Vancouver Creosoting Co., which only recently began operating its new big plant in North Vancouver. The contract amounts to \$150,000, and the piles will be used in the extension to Pier D, which the C. P. R. is now undertaking. A large number of the piles will be 130 feet in length.

Montreal, Que.—The Montreal & Southern Counties Railway Co. has placed an order with the Ottawa Car Co. for six new electric interurban passenger cars, consisting of three motors and three trailer cars. The new cars will be three-five feet long, with a seating capacity of sixty-two passengers. They will be equipped with four 50-horse power motors, improved Peter Smith heating and ventilation systems, smoking compartment.

MARINE

St. John, N.B.—The Eastern Steamship Corporation fleet of steamers, docks and warehouses, etc., have been purchased by Hayden, Stone & Co., of Boston, on behalf of a syndicate, who will reorganize the corporation. The price paid was \$3,366,000, which includes a large interest in the Boston and Yarmouth Steamship Co.

1916 Lakes Season.—The lake marine season of 1916 will be known as the longest on record, boats encountering ice at the start and finish. Thirteen vessels passed out of existence during the nine months of navigation, but most of them were small and only two were lost in collisions. Two boats stranded and were total losses; three were destroyed by fire, and six foundered. Four of the lost vessels went down in the gale which swept Lake Erie on Oct. 20, and the steamer "Merida," which went down with all hands, was the biggest monetary loss. She was insured for \$200,000. The loss on the S. R. Kirby, which went down in Lake Superior early in the summer, was the next greatest loss. She cost the underwriters \$120,000. Total loss of life was 70, as against 15 the year previous.

BUILDINGS

Toronto, Ont.—A new office building and warehouse will be erected at 69 Adelaide Street West, by S. Frank Wilson & Sons, publishers. Plans for the building are not yet complete, but, according to present intentions, it will be either of brick and steel, or concrete and steel construction, 68 by 200, and probably nine storeys high.

The A.R. Williams Machinery

— ❖ — Company

Limited — ❖ —

64-66 Front St. West,
Toronto



St. John, N.B., Winnipeg,
Vancouver

TWO OPPORTUNITIES

WE offer for sale at Swissvale, Pa., a complete Forging Plant suitable for 5" or 6" shells, consisting of Hydraulic Presses, Pumps, Accumulators and all accessories, ready to run with or without electric motor equipment as desired.

Also at Wilmerding, Pa.

A complete plant for the manufacture of 18-pdr. British Shrapnel Bullets. Labor required, four men. Complete list below.

the manufacture of bullets for These Presses, etc., used in the 18-pdr. British Shrapnel.

- 3—3-ton Quigley Lead Pots (one new) with cast iron parts for three furnaces.
- 3—Water-jacketed Slug Molds with stands.
- 1—Slug Mold Car for narrow gauge track.
- 2—Slug Heating Furnaces.
- 2—J. Robertson & Son Triplex Hydraulic Pumps with valves and fittings to connect with Extrusion Presses.
- 2—J. Robertson & Son 650-ton Hydraulic Extrusion Presses.
- 2 Automatic Reel Winding Racks. (Six reel capacity.) (Structural steel.)
- 2 Reel Racks (24 reel capacity) structural steel.
- 72—Reels.
- 12—2-ton capacity built dump buckets.
- 2—No. 75½ Bliss Power Presses.
- 6—Bliss Tumbling Barrels.

Write our office at Swissvale for full information, and make arrangements for inspection.

The A. R. Williams Machinery Co., Limited
TORONTO ONTARIO

TRADE GOSSIP

St. Catherines, Ont.—The St. Catherines Brass Works are building a foundry.

Guelph, Ont.—The International Malleable Iron Co., propose building an extension to their foundry.

Britain Requisitions Copper.—Supplies of unwrought copper have been requisitioned by the British Government.

Victoria, B.C.—The Aetna Iron & Steel Co., is applying for a site on the terminal area on which to erect a plant.

Sudbury, Ont.—The Murray Mining Co., are negotiating for hydro power for the development of a mining property three miles from here.

New Munitions Credit.—Another credit of \$50,000,000 by Canadian banks to the Imperial authorities for munitions is announced. This makes a total of \$250,000,000 provided in Canada.

Cobourg, Ont.—The Federal Steel & Foundry Co., are having plans prepared for a steel plant and rolling mill to cost about \$250,000. T. H. Cole of the Corbett Foundry & Machine Co., Owen Sound, Ont., is manager.

Armstrong, Whitworth Co. of Canada, Ltd., Montreal, who are represented in Winnipeg by Kelly Powell, Ltd., are considering opening up a Vancouver branch with the view of developing their business in mining drills, steel, etc., throughout the mining districts of British Columbia.

Winnipeg, Man.—Application will be made at the next session of the Legislative Assembly of the Province of Manitoba for an Act to incorporate the Transcona Electric Railway Co., with power to build, operate and equip electric railways, and to do an electric light, power and gas business.

H. W. Petrie, of Montreal, Ltd., Montreal, are opening a large department for the sale of wholesale and retail automobile supplies and accessories, in addition to their regular line of iron and wood working machinery. A. Carriere, formerly with John Millen & Sons, Ltd., Montreal, is in charge of this department.

Armstrong, Whitworth of Canada, Ltd., has just opened new, larger, and up-to-date offices in Montreal at Nos. 298-300 St. James Street. The new premises consist of three floors and basement. It is the intention to carry a very complete stock of their product, in order to ensure quick delivery, particularly of small orders.

Samuel Osborn, Canada, Ltd., will shortly establish a plant in Montreal for the purpose of manufacturing high-speed tools for machine shops and special uses. They will also have a hardening plant in charge of a Sheffield expert for treatment of steels. This arrangement will enable the company to make quicker delivery and give better service generally to their customers.

Montreal, Que.—The machinery and equipment for the new line plant which the Armstrong Whitworth Co., are

building is arriving, and they hope to have the two new six ton Heroult furnaces in operation in from 60 to 90 days.

Toronto, Ont.—Forgings, Ltd., 27 Atlantic Avenue, has taken out a building permit to instal three fuel oil tanks at a cost of \$2,000.

Canadian Pneumatic Tool Co.—At a meeting of the directors of the Canadian Pneumatic Tool Co., held recently in New York, George J. Sheppard, who has been connected with the concern as manager for a number of years, was elected vice-president. This honor was conferred on him in appreciation of his efforts in making the Canadian subsidiary a success. He retains his position as Canadian manager, W. O. Duntley being the president, and W. B. Seelig, secretary-treasurer. It is the intention of the directors to erect an up-to-date factory in Canada, with a view to coping with future trade conditions.

Lack of Ocean Tonnage.—Lack of ocean tonnage may prevent the shipment of the fifteen hundred miles of steel rails which the Canadian Government undertook to supply for use in France. Canada is providing the rails, and if the British Government can get them across the ocean, the arrangement entered into two weeks ago will be carried out. The tonnage now available, however, is insufficient, and if no more is forthcoming the rails can hardly be transported with the expedition that is necessary. Three hundred miles of steel from the Government railways are going across at once. If the rest cannot be taken over in time it is assumed that steel mills in Great Britain will be used to turn out what is required.

To Use Canadian Woods.—Canadian lumber merchants will be glad to learn the decision of the British War Office to make larger use of Canadian woods in the future manufacture of articles required for war purposes. This agreement is the outcome of representations made by Sir George Perley, who put the lumbermen's case strongly before the authorities, more especially as regards red and white pine. Specimen, prices and samples of pine were submitted to the War Office, with the result that an inspector of equipment and supplies has furnished for the merchants' guidance lists of 68 articles in which the use of Canadian woods will be provided for in the specifications governing their manufacture.

TENDERS

Winnipeg, Man.—Tenders will be called until February 12, 1917, for works required for the completion of the new Parliament Buildings, which include the following: Heating and ventilating, electric conduit and wiring. Thos. H. Johnson, Minister of Public Works, Winnipeg.

St. Lambert, Que.—Tenders will be received up to January 22, for the supply of a horizontal shaft centrifugal pump, electric motor and switchboard. Specifications may be obtained from

H. A. Gibeau, Town Engineer, Town Hall, St. Lambert, Chambly Co., P.Q.

Toronto, Ont.—Tenders will be received, addressed to the chairman, Board of Control, City Hall, Toronto, up to January 16, for the installation of a 40 million Imperial gallon centrifugal sewage pump at the main sewage pumping station, Toronto. Specifications and forms of tender may be obtained at the Works Department, Room 6, City Hall.

Ottawa, Ont.—Tenders will be received up to January 15, for the construction of a reinforced concrete lighthouse tower and fog alarm building combined, and a wooden dwelling at Point Abino, Township of Bertie, Welland County, in the Province of Ontario. Plans, specifications, form of contract and schedule of wages, can be seen, and forms of tender procured, at the Harbor Master's office, Toronto, and at the post offices, Welland, Port Colborne, St. Catharines, Bridgeburg, Hamilton and Brantford.

INCORPORATIONS

The Kerr & Goodwin Machine Co., of Brantford, Ont., have increased their capital stock to \$100,000.

The Duncan Electric Co. has been incorporated at Ottawa with a capital of \$150,000 to manufacture and deal in electrical apparatus and supplies of all kinds at Montreal. Incorporators are J. H. Meagher, Henry W. Chanvin and James E. Coulin, all of Montreal.

The North Bay Toy Co. has been incorporated at Toronto, with a capital of \$100,000, to manufacture toys, wooden, tin and metal wares of all kinds at North Bay, Ont. The provisional directors are: Leonard W. Henderson, George Gordou and Howard H. Thompson, all of North Bay.

The Acme Oil & Gas Co. has been incorporated at Toronto with a capital of \$1,000,000 to acquire and develop mineral lands and deposits with head office at Sarnia, Ont. Provisional directors are William J. Barber, Clarence P. Smith and Frederick R. Reeves, all of Sarnia, Ont.

Port Arthur Shipbuilding Co. has been incorporated at Toronto, with a capital of \$2,500,000, to take over the business of the Western Dry Dock and Shipbuilding Co., of Port Arthur, Ont. The provisional directors are: Donald R. Hosack, John G. Leekie, and Lorne L. Lillie, all of Toronto.

British Forgings, Ltd., has been incorporated at Ottawa with a capital of \$50,000 to cast, smelt, forge and roll iron and steel, also to operate blast furnaces, forges and converters. Head office is at Montreal and the incorporators are F. G. Bush, G. R. Dennon and A. G. Yeoman, all of Montreal.

The Jarvis Optical Co. has been incorporated at Toronto with a capital of \$40,000 to acquire the business of Charles A. Jarvis, of Brantford, Ont., manufacturer of optical supplies and instruments. Provisional directors are Charles A. Jarvis, Norman J. Penwarden, and W. S. Brewster, all of Brantford, Ont.

PERSONAL

William Sherman Smith, harbor master of Dalhousie, N.B., for over twenty years, died on January 4, aged 65.

Bertram Dawson, president of the Dickson Bridge Works Co., Cambellford, Ont., died on Dec. 31, aged 36 years.

Capt. H. N. McMaster has been appointed Marine Superintendent of the Montreal Transportation Co., at Kingston, Ont. He has been assistant superintendent since 1913.

John Grundy, engineer at the works of the Canada Carriage Co., Brockville, Ont., was accidently killed on Jan. 1, in the performance of his duties. Deceased was 65 years of age.

Robt. Patterson, for forty-one years an employee of the G. T. R. and for the last seventeen years master mechanic in the repair shops at Stratford, Ont., has been placed in charge of the General Car & Machinery Co. plant at Montmagny, Que. His appointment was made by the Imperial Munitions Board, Ottawa, and the Grand Trunk is releasing him for the period of the war. Charles Kelso will act as master mechanic at Stratford in the interval.

Hugh McCulloch, one of Galt's most prominent residents, died there on January 8, in his sixty-first year. He was president of the Goldie & McCulloch Co., vice-president of the Galt Malleable Iron Co., and of the Galt Art Metal Co., and a director of the Gore Mutual Fire Insurance Co. A native of Galt, he was closely identified with the industrial progress of the city, but never held municipal office. He was educated at Whitby Grammar School and Upper Canada College.

INCORPORATIONS

The **Empire Brush Co.** has been incorporated at Toronto, with a capital of \$40,000, to manufacture brushes and brooms of all kinds at Toronto. Incorporators are: Samuel Scott, Abraham Shulman, and Wilfred H. Taylor, all of Toronto.

The **MacFarlane Shoe Ltd.**, has been incorporated at Ottawa with a capital of \$400,000 to manufacture boots and shoes of all kinds at Montreal. The incorporators are Walter S. Johnson, F. W. Fairman and William S. Wilson all of Montreal.

Daylyte Lamp Co. has been incorporated at Toronto, with a capital of \$200,000, to manufacture lamps and electrical supplies of all kinds at Guelph. The provisional directors are: James E. Carter, John Davidson and John Kennedy, all of Guelph, Ont.

The **Cluff Ammunition Co.** has been incorporated at Ottawa, with a capital of \$1,500,000, to manufacture explosives and munitions of all kinds. Head office at Toronto. The incorporators are: Arthur W. Holmsted, Lorne F. Lambier and Norman R. Kay, all of Toronto.

STEEL CASTINGS

We are in a position to make immediate delivery of all kinds of steel castings, 100 lbs. and heavier.

Send us your next order.

Dominion Steel Foundry Co., Ltd.

Hamilton, Ont.



OVENS

Enameling and Varnishing.
OVENS Heated by
GAS, ELECTRICITY, STEAM or COAL
Write for New Pamphlet Just Issued
Brantford Oven & Rack Co., Ltd., Brantford, Canada

We are qualified Tool, Die, Jig, Gauge and Fixture Makers.

WRITE US.

Windsor Machine & Tool Works.
WINDSOR, ONT.



WEBBER BROS. MACHINE COMPANY

Gear Blanks, Shell Punches, Boring Bars, Special Tools.

Machinery of all kinds built to your specifications.

Better Work. Reasonable Prices.
848 Dupont St., Toronto.
Phone Hill. 2746

METAL STAMPINGS

We are manufacturers of stamped parts for other manufacturers.

We do any kind of sheet metal stamping that you require. Our improved presses and plating plant enable us to produce the finest quality of work in a surprisingly short time.

We can finish steel stamping in Nickel, Brass or Copper.

Send us a sample order.

W. H. BANFIELD & SONS

372 Pape Avenue, Toronto, Can.

The Provost Mfg. Co., has been incorporated at Ottawa with a capital of \$50,000 to manufacture stump pullers, trucks, wagons etc., at Edmonton, Alta. The incorporators are Pierre Provost of Legal, Alta., also George H. Stoddart and John, C. Sherry of Edmonton.

Forgings, Ltd., has been incorporated at Ottawa, with a capital of \$100,000, to manufacture forgings of all kinds, munitions, and explosives, etc., with head office at Toronto. The incorporators are: William H. Irving, Henry H. Davis and Edward H. Brower, all of Toronto.

The Spencer Heating Co., of Canada, Ltd., has been incorporated at Ottawa, with a capital of \$500,000, to manufacture boilers, heaters and furnaces of all kinds, with head office at Toronto. The incorporators are: Tilman H. O'Neil, Albert T. Hawley, and Hugh Polson, all of Winnipeg.

South Bay Power Co. has been incorporated at Toronto, with a capital of \$1,000,000, to operate power plants in the Sudbury and Temiskaming districts of Ontario, with head office at Toronto. Provisional directors are: A. Fasken, G. H. Sedgwick, and Duncan McArthur, all of Toronto.

Standard Stampings, Ltd., has been incorporated at Ottawa, with a capital of \$45,000, to carry on the business of stampers, founders and metal workers, with head office at Toronto. The incorporators are: James F. Edgar, Norman R. Tyndall, of Toronto, and James E. Maybee, of Port Credit, Ont.

Atlas Metal & Alloys Co., of Canada Ltd., has been incorporated at Ottawa with a capital of \$50,000 to carry on the business of metal workers, machinists and smelters with head office at Montreal. Incorporators are C. M. Holt, Alexander Chase-Casgrain and Errol M. MacDougal all of Montreal.

The Stave Mfg. Co. has been incorporated at Ottawa, with a capital of \$50,000, to maintain and operate saw mills and planing mills, also to manufacture staves and woodenware of all kinds, with head office at Montreal. The incorporators are: Harold Wooland, Walter H. Thomson and Walter F. Lee, all of Montreal.

The Michipicoten Power & Paper Co., has been incorporated at Ottawa with a capital of \$6,500,000 to manufacture pulp, paper and paper substitutes of all kinds with head office in Toronto. The incorporators are William A. J. Case, James B. Taylor and William M. Smith all of Toronto.

The St. Catharines Machinery Co. has been incorporated at Toronto, with a capital of \$40,000, to manufacture machine tools and machinery of all kinds, at St. Catharines, Ont. The provisional directors are: George Wilson, E. W.

Marks and Harry Shortt, all of St. Catharines, Ont.

The Lytle Engineering Co., has been incorporated at Ottawa with a capital of \$50,000 to manufacture all kinds of engineers and mill supplies and to carry on the business of iron and brass founders, engineers and millwrights etc., with head office at Montreal. The incorporators are F. G. Bush, G. R. Drennan and H. W. Jackson all of Montreal.

CATALOGUES

The Cling-Surface Co., 1057 Niagara Street, Buffalo, N.Y., have issued a very unique calendar of special interest to engineers and will gladly send a copy of anyone who applies to them.

Trucks and Turntables.—The Whiting Foundry Equipment Co., Harvey, Ill., have issued a catalogue, No. 124, superseding No. 78. This catalogue illustrates and describes a varied line of steel trucks, charging cars, turntables, buckets, core oven cars, etc.

Electric Hoists.—Bulletin M-I, of the Shepard Electric Crane Co., Montour Falls, N.Y., gives particulars of floor-operated electric hoists up to one ton capacity. The bulletin also contains a figured diagram accompanied by a table giving the corresponding dimensions.

Collapsing Taps.—Bulletin No. 34, issued by the Modern Tool Co., Erie, Pa., describes and illustrates the "Modern" adjustable collapsing taps. The principal features and construction of this type of tap are dealt with fully. Copies of the bulletin may be had on request.

Scientific Lubrication of Cutting Tools is the title of a bulletin published by the Cincinnati Lubricant Pump Co., Cincinnati, Ohio. The opening pages of the bulletin cover the history of cutting tool lubrication, followed by another dealing with the use and application of lubricant or "coolant" as it is termed. In the latter part of the bulletin, the "Fullflo" lubricant pump is described and illustrated and its merits dealt with fully.

Mechanical Stoker.—Bulletin B-2 deals with the type "E" underfeed stoker made by the Combustion Engineering Corporation, New York. The bulletin contains a full description of this stoker, particular attention being given to the principal features embodied in its design and operation. The illustrations show sectional views of the stoker and illustrations under various types of boilers.

Crossley Oil Engines.—A bulletin dealing with the new Crossley oil engine for running on crude, residual and refined oils, has been issued by Crossley Bros., Ltd., Openshaw, Manchester, England. The bulletin contains full details cover-

ing the design of this engine and its attachments, while the advantages claimed for it are given in detail. Reference is made to the economical fuel consumption of the engine, and its adaptability for burning various qualities of crude and residual oils. Details of a test on a 95 h.p. engine are included. The bulletin is fully illustrated.

Ammonia Fittings and Supplies.—The Canadian Ice Machine Co., Toronto, are distributing a new high class catalogue, dealing with the "York" ammonia fittings and supplies. This catalogue, which supersedes all previous issues, illustrates and describes standard types of fittings, etc., for which patterns are already made. A complete line of fittings and supplies is dealt with as used in refrigeration plants, the first part being devoted to fittings and the second covering various types of condensers, ammonia receivers, coolers, distillers, oil and steam separators, brine coolers, and filters, etc. An extensive line of valves and fittings are illustrated, accompanied by tables giving the principal dimensions for each size. The concluding pages contain views of numerous installations featuring various types of "York" refrigerating machines. The catalogue contains 132 pages, with exceptionally good half tones. Copies may be had on application by interested readers.

Star Grinding Wheels is the title of catalogue No. 9, issued by the Star Corundum Wheel Co., Detroit, Mich., which deals with an extensive line of grinding wheels for all purposes. The three processes by which these wheels are made are briefly described, followed by a table showing general uses of grinding wheels and the process of manufacture best adapted and usually employed. Other useful tables deal with grinding wheel speeds, weights of wheels, decimal equivalents, selection of grades, etc. The catalogue contains a number of suggestions for taking care of wheels, ordering and rules for calculating speeds. There are also a number of rules for calculating list prices for various shapes to be used in conjunction with the price lists. A large number of grinding wheels of various shapes for different makes of grinding machines are illustrated together with the principal dimensions and prices. A safety code for the use and care of abrasive wheels is distributed with the catalogue. This is a very useful catalogue and is gotten up in an attractive manner.

BOOK REVIEWS

Ford Methods and the Ford Shops. By Horace Lucien Arnold and Fay Leone Faurote, 440 pages, 7 x 10 inches. Published by the Engineering Magazine Co., New York. Price \$5. This book which is one of the latest additions to the Works Management Library, is a re-

print of a series of articles that appeared in the *Engineering Magazine*. It was written for the most part by H. L. Arnold, but completed by F. L. Faurote after Mr. Arnold's death. Both authors worked with the direct co-operation of Henry Ford himself, and of the Ford engineers.

Graphical Solutions of Electric Railway Problems.—In an effort to overcome the difficulties attendant upon the use of analytical methods in the solution of electric railway problems involving the characteristics of motive power, A. M. Buek, of the Engineering Station, University of Illinois, has developed a series of graphical methods which supply an accurate and easy means of attack applicable to any possible combination of electric motor characteristics and any range of conditions which may be met in practice. Diagrams have been developed to set forth the relationship between motor current and speed, between current and tractive effort, between speed and tractive effort, between speed and time, etc. The results of Professor Buek's studies are set forth in Bulletin No. 90 of the Engineering Experiment Station. Copies may be obtained on request from W. F. M. Goss, Director, Urbana, Illinois.

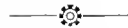

Railroads Use Heavier Rails.—The C. P. R. is giving out large rail orders, including 30,000 tons of 80-pound rails and 30,000 tons of 100-pound rails for 1917 delivery. As the Canadian mills are working overtime and orders are greatly ahead, the company is making inquiries in the outside market. The heavier rails, which our railways are constantly laying down, is a reminder of the radical change which has taken place with respect to freight transportation in the course of the past decade. The question of mere existence causes the railways to consider the matter of a doubled capacity—longer and heavier trains, cars double the size, locomotives of double power and haulage capacity, heavier bridges to sustain added weights, and 100-pound rails to sustain the doubled weight of traffic. All that was accomplished at the outlay of many millions by the C. P. R. and Grand Trunk. It solved the question, not only of mere existence, but of dividends. But for this departure the mileage in the hands of the receivers on this continent would be double what it is to-day.



The Cleveland Twist Drill Co., Cleveland, O., are distributing an attractive calendar, the upper part of which is entitled "The Critical Moment." It consists of a photogravure in colors, and depicts the critical moment in the making of a twist drill.

**PATENT
ATTORNEYS**

BABCOCK & SONS
ESTAB. 1877
PATENTS—TRADE MARK—DESIGNS
IN ALL COUNTRIES
Book "Patent Protection"—free. Master of Patent Laws, Formerly Patent Office Examiner.
99 St. James St., - Montreal, Que.
Branches: Ottawa, Washington.

RESEARCH BUREAU
REPORTS BY EXPERTS ON SCIENTIFIC, TECHNICAL AND INDUSTRIAL DEVELOPMENT.
SPECIAL RESEARCHES ARRANGED.
PATENTS, TRADE MARKS, ETC.
HANBURY A. BUDDEN CABLE ADDRESS
712 DRUMMOND BLDG., MONTREAL "BREVET"

**PATENTS
PROMPTLY SECURED**
In all countries. Ask for our Investor's Adviser, which will be sent free.
MARION & MARION, 364 University St.
Merchants Bank Building, corner St. Catherine St., MONTREAL, Phone Up. 6474 and Washington, D.C., U.S.A.

PATENTS
Fetherstonhaugh & Co.
Patent Solicitors, Head Office, Royal Bank Bldg., Toronto, Ottawa Office, 5 Elgin St. Send for our Plain Practical Pointers. Copy of National Progress, in which our patents are advertised, mailed free.

INDUSTRIAL CARS, FLOOR-TRUCKS, PORTABLE STEEL TRACK, TURNTABLES.
Hamant Car & Engineering Works
Hamilton, Canada

THE IRON WORKS LIMITED
Successors to
Owen Sound Iron Works
Owen Sound, Ont.
**Engineers
Boiler-makers
Founders
Machinists**

Tank Work
Smoke Stacks,
Grey Iron and
Brass Castings,
Special
Machinery
Made to
Order



Stop That Waste of Water

Did you ever stop to think how many gallons of water are wasted by the old-fashioned drinking faucet?
Puro saves 75% of that wasted water.
Puro does away with the old-fashioned unsanitary tin-cup; it is the Safety Sign of pure water in every factory where it has been installed. Employees like it because it is clean—because it insures a clean fresh drink—because it saves their time.
The Puro Sanitary Drinking Fountain has a positive control that eliminates spouting. Easily attached—positively fool proof—and nothing to wear out.
An excellent investment—for shop and office alike—and one that pays dividends in real money on water savings and better workers.
Write to-day—now—tell us how many men you have and the number of departments.
We'll make you a complete estimate on an installation we will also make you a special proposition for a try-out in any one department.
"PURO-FY" Your Water Supply
Puro Sanitary Drinking Fountain Company
**SAFETY PURO ECONOMY
FIRST PURO ALWAYS**
147 University Ave., TORONTO, CAN.

"Barnes-Made" SPRINGS

are unusual in service and wear

They are the result of sixty years' experience, unsurpassed equipment and highly skilled workmanship.
A trial will convince you that "Barnes-Made" Springs are the best buy.

Established 1852
THE WALLACE BARNES COMPANY
218 South St., Bristol, Ct., U.S.A.
Mfrs. of "Barnes-made" Products
Springs, Screws, Machine Products, Cold Rolled Steel and Wire

Classified Advertising Section

Rates (payable in advance): Two cents per word first insertion; one cent per word subsequent insertions. Count five words when box number is required. Each figure counts as one word. Minimum order \$1.00. Display rates on application.

FOR SALE

GAP LATHIE, 28 x 42 x 16 FT. BED, FOR sale, cheap. Guarantee Motor Co., Hamilton, Canada. (1)

ENGINE FOR SALE—50 HORSE-POWER Corlias; no reasonable offer refused if taken at once. Box 357, Chatham, Ont. (2)

BROWN-BOGGS MARKING MACHINE FOR 4.5 shella. Has been used for short time only, and is in good condition. Box 248, Canadian Machinery. (24)

FOR SALE—1 ¼-1½ MODEL A CLEVELAND automatic screw machine. F. T. Coffin, 17 Tudor St., Cambridge, Mass., U.S.A. (2)

FOR SALE—75 H.P. CANADIAN GENERAL Electric motor, 25 cycle, 3 phase, 550 volts, 950 R.P.M. In first-class condition. Box 258, Canadian Machinery. (26)

1 VERTICAL, SINGLE ACTION, DOUBLE cylinder hydraulic pump, 6" stroke, all ready to connect up; almost new; price \$75. McGregor & McIntyre, 1139 Shaw Street, Toronto. (1f)

FOR SALE—FIFTEEN HEAVY CAST IRON columns, from thirteen to seventeen feet long. Columns tapered and have good heavy base and top. Also four roof trusses. Sixty feet long. Ten feet in centre, eight foot at ends. Will cut columns to suit purchaser. Woodside Bros., Port Arthur, Ont. (2)

1—2-SPINDLE SHAPER, WOOD TOP, JOHN Ballantyne, Preston, make, used two months. 1 Dynamo, 45 lights, Toronto and Hamilton Electric Co. make. Used five months. Good as new. Box 195, Jordon, Ont. (R.T.F.)

FOR SALE—1 40 H.P. ROBB, ARMSTRONG high-speed engine; 1 4 x 1 Marsh deep well steam pump, and 1 Barton generator, 80 lamp capacity, with switch-board. All in good order and cheap for quick sale. Richards-Wilcox Canadian Co., Ltd., London. (20)

FOR SALE—TWELVE H.P. GAS OR GASOLINE Engine, Goold, Shapley & Muir Ident. In first-class condition. Cheap. Stedman Brothers, Ltd., Brantford, Ont. (21)

DOUBLE-END FEATHERSTONE AXLE cutting off machine with countershaft and equipment adapted for cutting off two 45 forgings at once. Bargain \$500. Medicine Hat Pump & Brass Mfg. Co., Ltd., Medicine Hat, Alberta. (1f)

FOR SALE — ONE 100 H.P. LINCOLN motor, 220 volts, 3 phase, 25 cycles, 750 r.p.m., complete with base and starting compressor, but without pulley. New. Electro Metals, Ltd., Welland, Ontario. (3)

SHRAPNEL SOCKET AND ADAPTER machinery, turret lathes, boring machines, cutting-off machines and thread millers tooled for operation. Globe Electric Machine Co., Hamilton. (1f)

FOR SALE, CHEAP ONE TWENTY-TWO inch by ten-foot bed Porter lathe; compound rest, steady rest, set change gears, large and small face plate, eighteen-inch four-jaw chuck, boring bar, four tool holders and taper socket fitted. New Prague Flouring Mill Co., New Prague, Minn., U.S.A.

2—30 H.P. PRACTICALLY NEW, LATEST type Canadian General Electric Company's 30 H.P., 60 cycle, 550 volt, 3 phase, 900 R.P.M. induction motors, with starting compensators and adjustable sliding base, pulley 14" diameter 8" face. Price \$500 each f.o.b. Sarnia, Ont. 1—20 H.P., same as above, pulley 11" diameter, 10" face. Price \$390 f.o.b. Sarnia, Ont. H. Mueller Mfg. Co., Sarnia, Ont. (3)

WANTED

WANTED—COMPLETE SET OF DRAWINGS or blue prints of Universal grinder, with all attachments. Box 251, Canadian Machinery. (1)

ONE AUTOMATIC SCREW MACHINE, capacity up to 1-in.; can use machine having had some service. Canadian Matthew-Gravity Carrier Co., 481 Richmond St. west, Toronto. (2)

WANTED—POWER-DRIVEN ROLLER 8' long, suitable to roll ¼" steel plates; state make, condition, time used. Give price and particulars to L'Air Liquide Society, corner First Ave. and Ernest St., Maisonneuve, Montreal.

WANTED—SMALL SCREW-CUTTING ENGINE lathe 12" or 13" x 5' or 6' bed, automatic feed, power cross feed, compound rest; must be cheap and lathe in good working order; give full particulars in first letter. J. W. M., Snite 34, Thelmo Mansions, Burnett St., Winnipeg, Man. (24)

WANTED — THE FOLLOWING EQUIPMENT for 18-pr. H.E. shells:—2 electric or steam baking ovens, 2 painting machines, 1 banding press and pump, 2 hand turning machines, 3 sensitive drills for drilling and tapping grub screw hole, 1 Bowser varnish pump, 1 marking machine. Send quotations to Box 253, Canadian Machinery. (24)

REPAIRING

ALL KINDS OF MACHINERY REPAIRED, rebuilt and installed. W. H. Sumbling Machinery Co., 7 St. Mary St., Toronto, Ont.

SITUATIONS WANTED

TOOL MAKER, ACCURATE, GOOD draughtsman, desires responsible position. Box 254, Canadian Machinery. (4)

SUPERINTENDENT, DESIROUS OF change, 18 pdr. shrapnel, and 6" H. E. shells. Box 247, Canadian Machinery. (26)

Shipment from Stock

2—No. 2 "Kempsmith" Full Universal Milling Machines.

1—"Lees Bradner" Thread Millers (Used, but in good condition), arranged for milling 2" 14 thread in Nose of 18-pdr. H.E. Shells. Price, \$1,150.00.

or

4—"Lees Bradner" Thread Millers arranged for milling 2" 14 thread in Nose of 4.5 Mark VII H.E. Shells. Price, \$1,375.00.

Williams & Wilson Limited

320 St. James St., Montreal, P.O.

MECHANICAL ENGINEER, EXPERIENCED in eighteen-pounders and six-inch nosed-in shells, with twelve years' drawing office, shop and general experience, will be disengaged shortly. Box 252, Canadian Machinery. (25)

EXPERT FOUNDRYMAN FAMILIAR with all modern foundry appliances, desires position as foreman or assistant in gray or malleable iron foundry. Box 250, Canadian Machinery. (25)

SUPERINTENDENT WITH TWENTY-nine years' broad mechanical experience in different lines of manufacturing desires permanent connection with well known concern in need of a broad gauge man of unlimited energy and enthusiasm; long proven executive ability, strong personality, unquestioned integrity, strictly temperance, positive aggressive character with good judgment; highest references. Answer Box 260, Canadian Machinery. (2)

SITUATIONS VACANT

TOOLMAKERS AND MECHANICS. APPLY Pease Foundry Co., Brampton; Junction 4341. (3)

WANTED—MAN TO TAKE CHARGE OF machine shop doing repair and new work. Must be up-to-date and able to show results. State experience and salary and when you can start. Apply Box No. 257, Canadian Machinery. (26)

FIRST CLASS GRIDLEY AUTOMATIC men wanted to set up Gridley automatic machines, also operators for same, highest wages paid, only first class mechanics need apply. Apply 47 Richmond St. East, Toronto. (24)

WANTED—NIGHT SUPERINTENDENT TO take charge of factory making 4.5 sockets. Apply Box 237, Canadian Machinery.

WANTED — FIRST-CLASS MACHINIST able to take charge of our repair shop. Apply Hull Iron & Steel Foundries, Ltd., Hull, Que. (23)

WANTED—SUPERINTENDENT CAPABLE of taking charge of 4.5 shell factory in central Ontario; must have had past experience on this particular shell, and must be capable organizer. Please state experience, salary required and all other information possible. Apply Box 259, Canadian Machinery. (3)

WANTED—EXPERIENCED MILL WRIGHT and Machinist to take charge of construction and repair work in growing factory. A man who has had experience as foreman preferred. An excellent opportunity for a first-class man. State when you can start, also experience and salary wanted. Apply Box No. 256, Canadian Machinery. (26)

WANTED—EXPERIENCED MECHANICAL Draftsman; one who has had some experience on machine design and factory layout preferred. Apply stating experience and salary desired to the Goodyear Tire & Rubber Co., Bowmanville, Ont. (26)

WANTED — TECHNICAL ENGINEER — steady, energetic, practical, to learn the business and take charge of the operating and construction departments of a firm manufacturing compressed gases, and apparatus to use such gases. Reply giving experience and salary expected to Box No. 255, Canadian Machinery, 701 E.T. Bank Bldg. Montreal. (26)

CANADIAN MACHINERY

AND MANUFACTURING NEWS

A weekly newspaper devoted to the machinery and manufacturing interests.

Vol. XVII.

TORONTO, JANUARY 18, 1917

No. 3

EDITORIAL CONTENTS

Preliminaries in Machine Part Production Methods—I	39
General	40-41
Importance of Uniform Driving in Textile Mills....Friction Clutches.	
Editorial Correspondence	42-44
Some Operations in the Manufacture of Saw....Milling Fixtures for Small Jobs....	
Graduating a Gauge in the Lathe.	
Spokes in Industry's Wheel	45
D. M. Medcalf.	
General	46-47
Boiler Inspection Report, Dept. Public Works, Province of Ontario Britain's	
Munitions Output....Passing of a Leading Canadian Manufacturer....Australian Re-	
striction on Canadian Shipping....Electrically Operated Gantry at Thor Iron Works,	
Toronto.	
Progress in New Equipment	48-49
Pressure Reducing Valve....Hydraulic Shrinker for Automobile Rims....Heavy Tur-	
ret Lathe....Die Forming Machine with Helical Cutters New Vernier Height	
Gauge.	
General	49-50
Mining in Alberta During 1916 Nova Scotia Steel & Coal Co. Canadian	
Revenue for Nine Months.	
Editorial	51
The Munitions Labor Situation....A Glimpse of Post War Trade Effort.	
Selected Market Quotations	52-53
The General Market Conditions and Tendencies	53-54
Montreal Letter....Toronto Letter.	
Industrial and Construction News (Advertising Section)	50-54

THE MACLEAN PUBLISHING COMPANY, LIMITED

JOHN BAYNE MACLEAN, Pres. H. T. HUNTER, Vice-pres. H. V. TYRRELL, Gen. Man.

Publishers of Hardware and Metal, The Financial Post, MacLean's Magazine, Farmer's Magazine, Canadian Grocer, Dry Goods Review, Men's Wear Review, Printer and Publisher, Bookseller and Stationer, Canadian Machinery and Manufacturing News, The Power House, The Sanitary Engineer, Canadian Foundryman, Marine Engineering of Canada.

Cable Address: Macpubco, Toronto; Atabek, London, Eng.

CANADIAN MACHINERY

AND MANUFACTURING NEWS

PETER BAIN, M.E., Editor. B. G. NEWTON, Manager.

Associate Editors: A. G. WEBSTER, J. M. WILSON, J. H. RODGERS.

CHIEF OFFICES:

CANADA—Montreal, 701-702 Eastern Townships Building, Telephone Main 1904. Toronto, 113-112 University Ave., Telephone Main 7324. Winnipeg, 22 Royal Bank Building, Telephone Garry 2313.

GREAT BRITAIN—LONDON, The MacLean Company of Great Britain, Limited, 88 Fleet Street, E.C., E. J. Dodd, Director, Telephone Central 129690. Cable Address: Atabek, London, England.

UNITED STATES—New York, R. B. Ince, 115 Broadway, N.Y., Telephone Rector 8971; Boston, C. L. Morton, Room 733, Old South Building, Telephone Main 1024. A. H. Byrne, 1104-5-6-7 Fort Dearborn Bldg., 105 W. Monroe St., Chicago, Telephone Radolph 3234.

SUBSCRIPTION PRICE—Canada, Great Britain, South Africa and the West Indies, \$3.00 a year; United States, \$2.50 a year; other countries, \$4.00 a year; Single Copies, 15 cents. Invariably in advance.

Hendey Millers will take any kind of a miller job

that comes into the modern shop

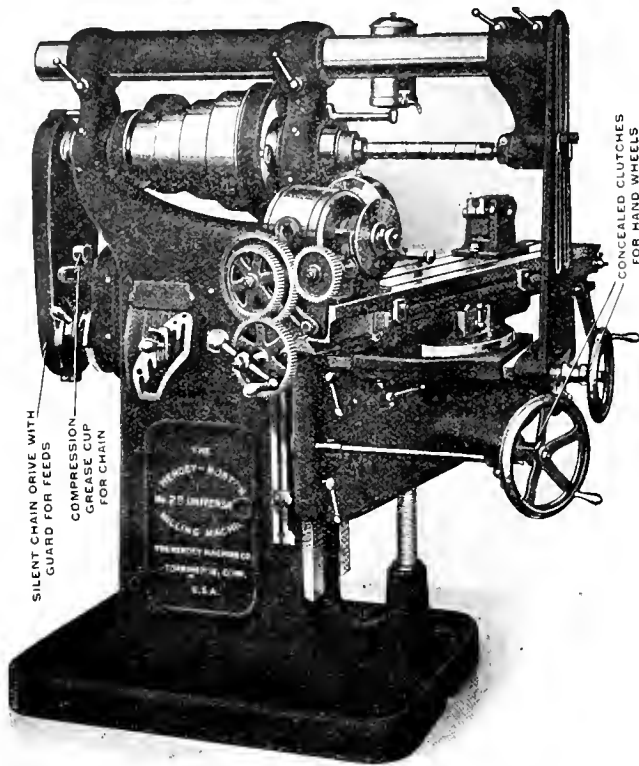

and it delivers the finished work in the highest degree of accuracy and perfection. It has a wide range of spindle speeds (16) and feeds (18).

The "Hendey" is free from the usual complicated features. All working positions are secured with but few and easily understood movements on the part of the operator. Anyone can operate the "Hendey Miller." No special skill is required to get the service that the Hendey's built for.

Write for the "Hendey Miller" Book. It is certain to interest you.

The Hendey Machine Co. Torrington, Conn., U.S.A.

Canadian Agents: A. R. Williams Machinery Co., Toronto, Ont.; A. R. Williams Machinery Co., 260 Princess St., Winnipeg; A. R. Williams Machinery Co., Vancouver; A. R. Williams Machinery Co., St. John, N.B.; Williams & Wilson, Montreal.

INDEX TO ADVERTISERS

A	E	M	S
Aeroplane Products, Ltd. 79	Eastern Machine Screw Corp. 28	MacKinnon, Holmes & Co. 54	Shuster Co., F. B. 77
Anderson, H. N. 72	Elmes Eng. Works, Charles F. 64	Main Belling Co. 71	SKF Ball-Bearing Co. 4
Armstrong Bros. Tool Co. 78	Eric Foundry Co. 85	Manufacturers Equipment Co. 28	Simmons Mach. Co. 60
Armstrong, Whitworth, of Canada. 19		Marsh & Henthorn 74	Skinner Chuck Co. 76
Atkins Steel Co., Wm. 11	F	Mathews, Jas. H., & Co. 78	Slocum, Avram & Slocum 68
Atlas Crucible Steel Co. 10	Fetherstonhaugh & Co. 54	McCabe, J. J. 66	Smalley-General Co., Inc. 22
Atlas Press Co. 78	Fitzgerald, W. H. J. 58	McCoy-Brandt Machy. Co. 58	Sparrett Co., L. S. 65
	Foss & Hill Machy. Co. 24	McDougall Co., R. Inside back cover	Steel Bending Brake Works, Ltd. 78
B	Foundry & Mach. Co. 24	McKay Co., James 72	The 78
Babcock & Sons 54		McLaren Belting Co., J. C. 78	Steel Co. of Canada 3
Baird Machine Co. 79	G	Mechanical Engineering Co. 62	Stenotype Co. 17
Banfield, E. J. 19	Gardner Machine Co. 21	Metals Coating Co. 69	Steinle Turret Mach. Co. 17
Banfield & Sons, W. H. 51	Garlock-Walker Machy. Co. 24	Metals Mfg. Co. 91	Steeple Co., John 55
Barnes, Wallace, Co. 51	Garvin Machine Co. 64	Milford Mach. Co. 16	Stocker, H. A., Machy. Co. 61
Beardry & Co. 77	Geometric Tool Co. 49	Molten Tool Co. 29	Stow Mfg. Co. 62
Bertram, John, & Sons Co. 1	Grant Gear Works, Inc. 79	Montreal Machy. & Supplies, Ltd. 72	Strong & Hery Co. 59
Biggs-Watterson Co., The 62	Grant Mfg. & Machine Co. 83	Morse Twist Drill Co. 83	Swedish Gage Co. 75
Blake & Johnson Co., The 29		Morton Mfg. Co. 61	Swedish Steel & Importing Co. 9
Blomt Co., J. G. 18	H	Mutch & Merryweather 60	
Brantford Oven & Rack Co. 53	Hamilton Mach. Tool Co. 67	Murphy Machine & Tool Co. 26	T
Bridgeford Mach. Tool Wks. 5	Hamilton Gear & Machine Co. 70		Tabor Mfg. Co. 78
Bristol Co. 76	Hanna & Co., M. A. 9	N	Taylor Instrument Co. 93
Brownell Machy. Co. 58	Hawthorne Bros. Co. 53	National Machine Tool Co. 77	Tivani Electric Steel Co. 76
Budden, Handbury, A. 64	Hendley Machine Co. 43	New Britain Machine Co. 55	Toronto Iron Works 76
	Herbarn, John T., Ltd. 19	New York Machy. Exchange 60	Toronto Testing Laboratory 79
C	High Speed Hammer Co. 83	Nicholson File Co. 68	Toronto Type Foundry 91
Canada Machinery Corp. Outside back cover	Hinoff Mach. Co. 89	Niles-Bement-Pond Inside front cover	
Can. Blower & Forge Co. 81	Howl Metal Co. 89	Northern Crane Works 76	U
Can. Desmond-Stephan Mfg. Co. 93	Hull Iron & Steel Foundries 66	Notton, A. O. 79	United States Electrical Tool Co. 87
Can. Economic Lubricant Co. 32	Hunter Saw & Mach. Co. 51	Norton Company 39	
Can. Fairbanks Morse Co. 32	Hurlbut Rogers Machy. Co. 77	Nova Scotia Steel & Coal Co. 8	V
Can. Inspection & Testing Laboratories, Ltd. 76	Hyde Engineering Works 29		Vanadium-Alloy Steel Co. 8
Can. Matthews Gravity Co. 53	I	O	Victor Tool Co. 28
Can. Metal Products Co. 77	Ideal Tool & Mfg. Co. 27	Oliver Machinery Co. 18	
Can. E. K. Morton Co. 15	Independent Pneumatic Tool Co. 87	Ontario Specialties, Limited 79	W
Can. Steel Foundries, Ltd. 7	Iron Works, The 51	Oven Equipment & Mfg. Co. 89	Warner & Swasey Co. 35
Carborundum Co. 29	J		Wells Bros. of Canada, Ltd. 30
Chapman Double Ball-Bearing Co. Front cover	Jacobs Mfg. Co. 77	P	Whiting Foundry Equipment Co. 89
Cincinnati Lubricant Pump Co. 74	Jenckes Machine Co. 9	Parmenter & Bulloch Co. 79	Whitman & Barnes Mfg. Co. 74
Cincinnati Pulley Mach. Co. 85	Jersey City Machine Co. 77	Peerless Mach. Co. 25	Whitney Mfg. Co. 18
Clark Equipment Co. 23	Jones & Glassco. 71	Petrie, H. W. 57	Wickes Brothers 16
Cleveland Pneumatic Tool Co. 87	Johnson Mach. Co., Carlyle 73	Perin, Wm. R. 64	Williams, J. H., & Co. 93
Clipper Belt Lacer Co. 51		Positive Clutch & Pulley Works 79	Williams Machy. Co., A. R., 7 and 93
Cook, Asa S., Co. 78	K	Pratt & Whitney Co., Inside front cover	Williams & Wilson 56
Cullen Machy. Co., C. E. 58	Kennedy, Wm., & Sons 12	Pringle, R. E., T. 27	Windsor Mach. Co. 53
Chapman Chuck Co. 76	King, Ltd., Warden 14	Puro Sanitary Drinking Fountain Co. 52	Winnipeg Gear & Engr. Co. 77
	L	R	Z
Davis, W. F., Machine Tool Co. 61	L'Air Liquide Society 89	Racine Tool & Machine Co. 25	Zenith Coal & Steel Products 79
Deloro Smelting & Refining Co. 6	Lancashire Dynamo Co. 85	Reel, Prunice Co. 51	Zin-Ho Mfg. Co. 68
Dept. of Finance 62	Landis Machine Co. 79	Ridout & Maybee 54	
Dominion Machy. Co. 14	Lymburner, Ltd. 91	Riverside Mach. Co. 59	
Dominion Steel Foundry Co. 53		Rockwell Co., W. S. 78	
Drury, H. A., Co. 7		Roelofson Mach. & Tool Co. 13	
		Roper, C. F., Co. 70	

IMPORTANCE OF UNIFORM DRIVING IN TEXTILE MILLS*

By Prof. G. F. Charnock.

THE money value of uniform turning and of close speed regulation in the driving of textile machinery is not appreciated as it ought to be. Steadiness and regularity of driving is an important factor in determining the maximum speed at which machinery may be run with the highest degree of efficiency. Uniform turning of the spindle is essential to the production of an even and level yarn, whilst in weaving, steady turning of the loom is of great importance in reducing the risk of broken threads. It will be recognized that for spinning and weaving machinery there is a maximum speed which the material will stand, and which must not be exceeded. To ensure the maximum output it is, however, desirable to approach this critical speed as closely as possible during the whole time the machinery is at work. The amount of yarn or of fabric produced depends upon the average speed, and the maximum possible efficiency as regards output would be reached when the average and maximum speeds coincide. The adjoining figure illustrates this point.

Taking a base line AB, a line CD is drawn to represent the maximum speed which must not be exceeded. Suppose the variation in speed occurring during the running of certain machinery amounts to 12 per cent., a figure which is frequently reached in the case of looms. At certain periods, the speed then falls to a minimum represented by the line EF, the fluctuation being shown by the wavy line of the diagram. The average speed, indicated by the line GH, will be

$$\frac{100 + (100 - 12)}{2} = 94 \text{ per cent.}$$

of the maximum, and so far as output is concerned, the efficiency might be stated at 94 per cent. Suppose now that it is found possible to reduce the speed variation from 12 per cent. to 4 per cent., the minimum speed is then given by the line IJ, and the curve between CD and IJ shows the fluctuation in speed between the extreme limits. The average speed is, therefore KL, or

$$\frac{100 + (100 - 4)}{2} = 98 \text{ per cent}$$

of the maximum, and the output has been increased from 94 per cent. to 98 per cent., or

$$\frac{98 - 94}{94} \times 100 = 4.2 \text{ per cent.}$$

If the speed variation could be re-

duced to 2 per cent.—an extremely doubtful contingency—the average would be 99 per cent. of the maximum speed and the increase in output as compared with the first ease would be

$$\frac{99 - 94}{94} \times 100 = 5.3 \text{ per cent.}$$

If it were possible to do away with speed variation altogether, the average speed would be 100 per cent. of the maximum, and the increase in output, as compared with a 12 per cent. variation, would be

$$\frac{100 - 94}{94} \times 100 = 6.3 \text{ per cent.}$$

This is, of course, a saving which is quite impossible of achievement in practice. Nevertheless, claims to effect an increase in output due to the cause named, and of much greater amount, in some cases as much as 30 per cent., have frequently been put forward. It is evident that such a result cannot be obtained, even in the case of a notoriously bad drive, by reduction of speed variation alone. Where any such saving has

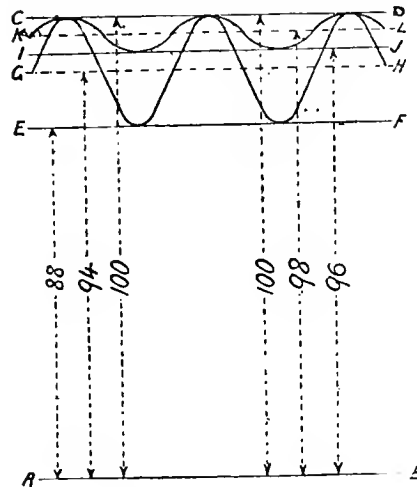

SPEEDS DIAGRAM.

been effected, it is much more likely to be due to a general speeding up of machinery which had previously been allowed to run at a speed much below the maximum permissible. Many such cases exist, and the ease with which a considerable improvement in output may be obtained in this manner is worthy of the attention of every millowner. The gain due to a reduction in speed variation of, say, 3 per cent., does not in itself appear to be a very striking matter, but if the mean speed can be increased 3 per cent. without increasing the maximum speed, this is equivalent per week of 55 hours to a gain of 1 hour and 39 minutes in actual time. Viewed in this light, the problem of close speed regulation is one which no power user can afford to neglect.

FRICION CLUTCHES—I.*

By W. G. Gass.

IT is a little difficult to know just where to commence the treatment of a subject like a friction clutch, which is not a machine in itself but only a part of machinery, and of which there is so great a variety, so many makers, and such extended use. It is not therefore proposed to deal with any one type, but to review the general types into which they may be classified, to refer to their common points and detail, and as far as possible their weaknesses and faults; not with the idea of extolling one type against another, but by bringing their faults to view to help towards their removal, for it is only by consideration of weak points that we can strengthen them. It may be taken as an axiom, that though one type of clutch may have advantages over another, there is not any perfect clutch, some types answering better than others for different classes of work; this is a great point to bear in mind when arranging clutch drives.

Clutch Types

We may commence by defining a clutch as a mechanical device by which rotary motion is transmitted from a first motion shaft to another or second motion shaft, which may be either in the same straight line or parallel with it. Clutches are divided into a number of distinct types:—Claw couplings, friction cones, internal segment and band clutches, external segment and band clutches, plate clutches, brush clutches, magnetic clutches, automatic clutches.

Claw couplings cannot be generally classified as friction clutches, but they can be and are combined with a friction slipping device by which some of the shock is absorbed when thrown into gear with the prime mover when rotating. Without any friction they are very useful on machines where the load is not very great, as they have all the advantages of giving a drive with no chance of slip. Where used for transmitting heavy loads, or at high speeds, they should only be put in gear when the machine or shafting is stopped. They are also very difficult to release when transmitting heavy loads.

Friction Cones.—These are the simplest form of friction clutch, and for some purposes the best, because simple in construction; if properly made they drive very well. They have the serious defect for general use of requiring to be held up with a constant pressure, which absorbs power and causes wear on the setting-up gear, with the bear-

*Read before the Manchester Association of Engineers.

*From Journal of Department of Textile Industries in City of Bradford Technical College.

ings taking the thrust of the setting-up gear. A portion of the constant thrust can be eliminated by making the angle of the internal portion sufficiently small, but this makes the cones liable to stick, and it is not infrequent, when large cones are so made, to have to hammer the outside of the cone to make the two portions come apart. If, on the other hand, the cone angle is too large, the pressure required to keep the two parts in gear is so great that it is very difficult to transmit the power. Generally these large cones are used for driving machinery in bleach-works and similar places, and are useful where there is a good deal of wet about. They are usually made of cast iron, the inner part sliding on the shaft on float keys, the outer part running loose on the shaft. They have been tried as double cones with internal and external bearing surfaces, but there is nothing to justify such an arrangement. If covered with some frictional substance such as leather, or any of the numerous frictional materials made for the purpose, the driving power is increased.

In motor cars the cone has proved a most valuable type, as the usual conditions are reversed, and it is as a constant driver that its value comes in. The arrangement in motor cars is such that there is no end thrust except when it is not transmitting power, and is, therefore, working under the best conditions.

Internal Segment or Band Clutches.—These are divided into two distinct types, those in which the internal segment is in two or more sections, which are forced apart—by means of screws usually, and those in which the internal segment is cast all in one piece, so arranged, that the driving portion is expanded against the spring of the metal. This type is made in two forms; in one case the segment is sprung apart in two points, and the other in one place only. Similar forms are made with hinged portions. In the loose segment type, the segments are carried on the arms of a turned internal piece, usually keyed on to the shaft as driver, but in other cases sliding in grooves made to receive them in the driven portion.

The External Segment or Band Clutch, is made in quite as many forms as the internal band type, but is more generally used for the smaller powers. The segments are in two, three or four pieces forced on to a central drum and carried in much the same way as the previous type. A single band similar to brake drum strap gripping on a central drum and set up by a wedge is one form; another has two bands and is set from opposite sides. Another

takes the form of a spring coil which tightens up by tension and friction, and is, in fact, an external cone clutch with a flexible rim. It is not usual to consider a fast and loose pulley drive as a clutch, but it comes under this head, the belt being the external friction band.

A Plate Clutch is distinct from any of the other forms, as the gripping surface is between two or more flat plates pressed together, one plate being attached to the driver and the other to the driven alternately. These are forced together by levers through a toggle joint. Another form of this type has the plates of stamped steel formed into a kind of double cone, which is supposed to give it extra gripping powers.

Brush Clutches.—These utilise the resistance of a great number of projecting wires, which when the two portions are pushed together, interlock and give the necessary power of driving.

Magnetic Clutches have generally two flat faces, though conical surfaces have been used, which are pulled together by the power developed in an electro magnet formed in one half the clutch.

Automatic Clutches depend on centrifugal action to keep the surface in contact, and are used in connection with electric motors, being designed usually to come into operation at certain desired speeds. The foregoing brief summary of the different types makes it evident that their number is very great, and that it would take more than the space available to describe them in anything approaching detail. They, however, all possess good points and faults in common, and it is these which it is proposed to consider as well as their other features in what follows:

Driving Surfaces

These are for the most part metal on metal, usually cast iron on cast iron. In cones, and in internal segment clutches, in the old days they used to be covered with copper plates riveted on by copper rivets. Many of the oldtime millwrights, particularly in bleach and similar works, would not have anything else, but there are not many made so at the present time. Copper covering did not materially increase the driving power, but it was generally believed to do so. If the clutch were heavily loaded there was a tendency for the copper to creep and shear the rivets. Examination of the surface of the copper after long work showed the surface to be embedded with fine particles of iron from the outer part of the cone or clutch, and it became hard and glazed, the pieces of embedded iron being hard and exceedingly sharp.

There are several kinds of friction material now made which are recommended for clutches. These, no doubt are of advantage for brakes, but there are difficulties in the way of using them for clutches. In most cases rivets have to be depended on, and these are apt to give way. The material is liable to glaze, particularly where the clutch goes in and out many times. Wooden blocks as driving surfaces act very well if the load is not excessive, but if overtaxed they char on the surface and give way. Where steel is used it should not rub on cast iron unless its surface is chilled very hard, or, if on steel, on a casehardened surface. Some of the smaller kinds of clutches use two hardened surfaces, but this must reduce the driving power.

In plate clutches, cast iron on cast iron is, in the author's opinion, best, mild steel on cast iron being a failure. One clutch uses a double cone arrangement in which the pressure is on the inside and the outside, and steel plates are used throughout. A great deal is claimed for this, and it is satisfactory as long as it is attended to and not overloaded. In motor cars, leather faced cone clutches are in the majority, and the results justify their popularity; they have to work so much as a slipping clutch that metal to metal surfaces have not proved satisfactory unless lubricated. In these, the co-efficient of friction is of course higher than metal to metal. In magnetic clutches, fibre on iron is usual, and they are said to give good results.

The trouble of driving surfaces is that they wear away, and this wearing is greater or less as the clutch slips or not. It is obvious that faces of metal cannot slip on one another under pressure without wearing away, and the examination of surfaces which have been in use shows the way in which the loss occurs. The surfaces generally being dry, a small portion of metal gets embedded into whichever of the surfaces is the softer, and acts as a kind of plough into the other. It is not necessarily the softer of the two which gives way, but often the harder. This does not sound quite reasonable but it is a fact. If you take a lead plate and cover it with particles of emery it will cut away the hardest steel. It is not, of course, the lead plate that cuts but the emery. The same thing occurs with the clutch; particles of hard material get embedded in the softer and act as the cutting material, but only when the clutch is slipping, so that the wear may be slow or fast depending on whether the driving faces slip much on each other. This explains why clutches put in as slipping clutches are not often very successful.

EDITORIAL CORRESPONDENCE

Embracing the Further Discussion of Previously Published Articles, Inquiries for General Information, Observations and Suggestions—Your Co-operation is Invited

SOME OPERATIONS IN THE MANUFACTURE OF SAWS

By D. A. Hampson.

SAWS of all kinds are so common and so good that users of them take their good qualities as a matter of course and men in the mechanical trades seldom, if ever, give thought to the many processes required to produce them. There are very few of the tools and appliances and machines in use in such profusion to-day, and to which we owe so much, that could not be duplicated in any well equipped machine shop with a fair degree of success, if the shop had to do it but to turn out only one or two saws would be practically an impossibility.

A Specialized Line

Saws are made in a few plants only as their manufacture requires an equipment so extensive and expensive that only specialists with an enormous output can "make a go" of the business; specialization and quantity manufacture are directly reflected in the low prices which saws bring in the open market.

The manufacture of hack saws, butchers' saws, etc., is usually a separate business from the line of heavier saws for carpenters, lumbermen, and ice men and is usually carried on by specialists in that finer grade of work. Considering these larger saws, the steel of various "gauges" is received from the rolling mills in sheets and is cut up in shears, slitters, and punches to the required sizes and shapes. The various processes in manufacture might be named in their order—cutting to shape,

Press Work

Punch and die work enters largely into the saw business. All the teeth are cut in this manner. In the case of hand saws and the like having a straight-cutting face and a uniform shape and spac-

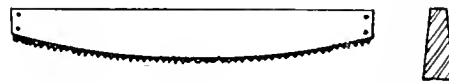

SECTION AT ANY PART.

FIG. 2. CRESCENT SAW.

ing of teeth, the punch press is provided with a feed and all that the boys tending the machines have to do is to put in the blanks—in shop nomenclature these saws are cut 8-point, 14-point, etc., according as they have 8 or 14 teeth to the inch. It will be inferred that the punch and die making department in any saw plant is a most important one; the work is hard on the tools for while saw steel does not average over 3-32 in. in thickness, it is tool steel of the best grade and the blank steel is punched in a black state with more or less scale on. Punches and dies are made as in all general practice. Punches are made to give about 2½ in. of length to use up in grinding and with this length have to be well backed up for stiffness. The clearances between punches and dies is made quite large partly because of the unskilled labor that sets the machines.

Grinding

Saw grinding is one of the special operations that is of more than passing interest. All the grinding is done wet on Ohio grindstones of varying face widths that start in at a diameter of 6 feet and

chine and driven by two long belts, one on each side. It is common practice to drive all the grinders from the line shaft S running along the wall at the back of the room, Fig. 1. Grinding requires a great deal of power and not infrequently one engine drives nothing but the grinding department shafting.

The saws are ground on top of the grindstone and by passing through and back much as the steel itself was rolled. The necessary downward pressure is obtained by passing the saw under a cast iron head block H directly over the highest point of the grinding wheel; pressure is regulated by screws on the head block connected through bevel gearing to the hand wheel W, which is

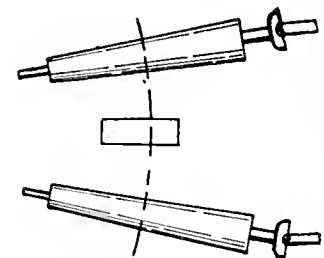

PLAN



ELEVATION

FIG. 3. ILLUSTRATING THE GRINDING OF CRESCENT SAWS.

large enough to be within the operator's reach as he stands on his platform. The wheel is dressed off perfectly straight and the head block ground to it—so the saws come out with a uniform cross section throughout. As the grinding pressure used is heavy, a powerful feed is required which takes the form of two pairs of rollers R, R, carried in bearings, adjustable vertically, in the side frames and driven from the main shaft.

Handling Work and Dressing the Stone

The method of dressing the stone and of returning the saw to the front of the machine are worthy of notice—so good and yet so simple as to be almost primitive. When the stone gets dull or out of shape, the grinder removes his platform, drops a bar B into sockets in the frame, and uses a piece of ¾ in. or 1 in. ordinary pipe for a dresser. To do this,

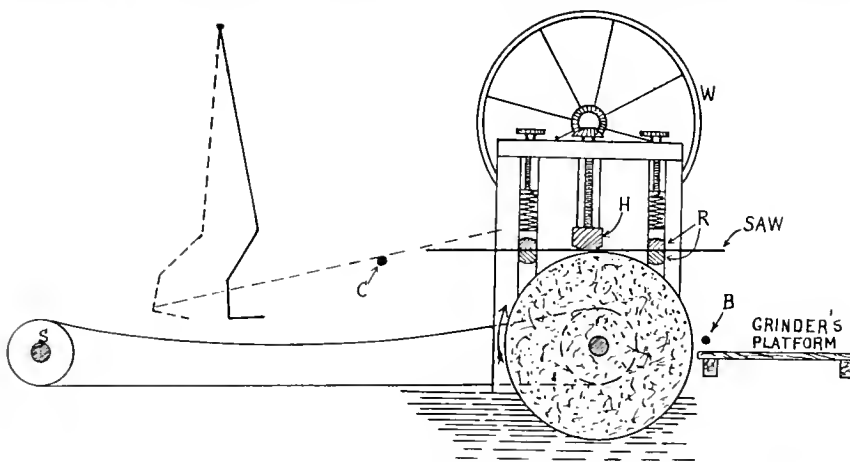

FIG. 1. DIAGRAM ILLUSTRATING PRINCIPLE OF SAW GRINDING MACHINE.

punching the teeth, grinding the sides, filing and setting the teeth, hardening, glazing or polishing, putting on handles, and packing.

are worn down to 2½ feet, a stone lasting from two to four weeks. The stones are mounted on a heavy arbor supported in the side frames of the ma-

he has to straddle the pit of water and put on a leather suit completely covering him from head to foot which is highly necessary for as he "goes to it" with the pipe he becomes enveloped in a cloud of dust and mist. From that cloud he emerges in ten minutes with his crude implement and a wheel straight to a thousandth thanks to that intangible thing called skill. Formerly it took two men to a machine, the grinder and his

adopted more rigid inspections. As the teeth are punched, they are straight across and have a rough sheared surface which must be filed smooth and at an angle. To-day all saws are machine filed except specials and samples of certain classes.

Though the machines for filing larger saws are quite large and elaborate, the bench machines employ the same general principle and are simpler to illus-

1 and 2, being a useful arrangement for cutting the spanner slots in circular nuts and other similar work. Ample rigidity and ease of operation are features of the design. The upper portion of the casting A is bored to receive the work spindle B, which is made a close fit in A, and has a collar formed at its centre in which a number of holes are drilled for the use of a small tommy bar when turning round. A dividing plate C is keyed on a

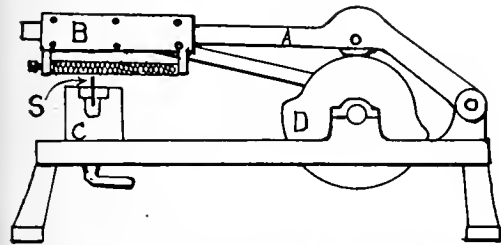
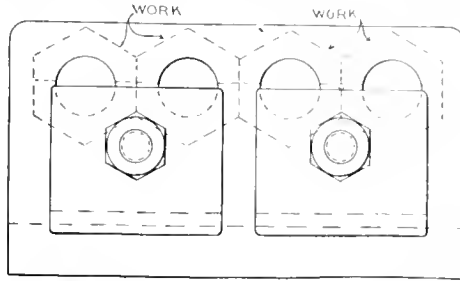
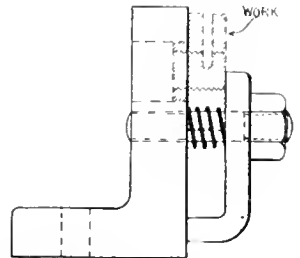

FIG. 4. SAW SHARPENING MACHINE.



FIGS. 3 AND 4. FIXTURE FOR SLITTING HEXAGONAL NUTS.



helper who "back tended" (passed the saw back over the rolls) but a studious fellow conceived the swing which is now used. This is made from a piece of sheet iron 36 in. square, and hung from the ceiling in such a position that the saw being fed through shoves it beyond its center and as it leaves the rolls it drops in the swing and lays over the rod C. The return of the swing to normal brings the saw within easy reach of the grinder.

Crescent Grinding

A departure from the grinding to uniform thickness may be found in what are called crescent ground saws—saws having a convex cutting edge with relief ground back equally from all parts of it. Some ice saws are this way, lumbermen's cross cut saws are now generally ground that way, and so are some others. This crescent ground relief is in addition to the set of the teeth and makes a very easy running saw for green wood, etc., etc.

The arcs of the cutting edge of these saws are of different radii, a fair average being 15 feet. To get this effect two pairs of tapering feed rollers are used on a regular grinding machine; these are set so that all lines on their surfaces would converge at a common point—the center from which the arc is drawn. Universals drive the rollers and the head block is set to bear more heavily on the "in" side, of course to be theoretically correct a set of rollers will do for only one size of saw, but with the aid of a gauge for grinding the saw when fed to the rollers, saws of different arcs can be crescent ground quite accurately, Fig. 3.

Saw Filing

The greatest labor saver ever introduced was the successful saw filing machine which came with the latter years of the last century. Before that, in every saw plant could be seen long rows of men and boys, filing saws for dear life, who made big money at piece work before the manufacturers included a limited file allowance in the price and

trate. They have many points which make them similar to the power hack saw. In bearings on top of the frame runs the drive shaft having at one end the disc D, which acts as a cam and a crank, Fig. 4. The crank pin and pitman drive the file holder B back and forth on the arm A which is raised on the return stroke of the file by the cam face of D and the cam roller. The saw S is held in a pair of grips which slide in the swivel block C which is set for the angle of the teeth. The file is held at an angle that is sufficient to move the saw one tooth at each forward stroke—no better feed could be desired. The tight pulley is on the main shaft and is always running, a simple pin clutch throwing it into gear. As alternate teeth are filed to the opposite angle these machines are run in pairs and the saws taken, still in its grips, from one machine and placed in the other to be finished.

The operations of hardening, straightening, and setting are all full of interest as is also that of handle making. Taken right through the operations and processes are the result of long study and experiment and produce to such a degree that they may well be copied and modified to suit conditions and work in other fields of mechanical endeavor.

reduced diameter and held in place by a washer and nut, the distance between collar and dividing plate being accurately adjusted to the length of hole in casting A. Hardened steel bushings are fitted to the dividing plate, which is held in the desired positions by pin D, passing through each hole in succession and engaging with a bushed hole in casting A.

The work, shown in dotted outline, is held on the other end of spindle by a slotted washer E, and nut F, care being taken to make the diameter of the nut across the corners slightly smaller than the spindle diameter. By so doing, the work can be slipped over the nut, washer E dropped into place, and the whole tightened up against spindle collar, the work being removed in the reverse manner.

The fixture shown in Figs. 3 and 4 was gotten out to increase the output of slit lock nuts such as are used on certain classes of electrical work, these having formerly been cut one at a time in a machine vise. A substantial cast iron angle was machined accurately on the bottom face and one side, and four holes drilled through the vertical web, these being accurately spaced so that the hexagonal nuts located themselves as shown. Two studs were then inserted in the positions shown and fitted with clamp plates for

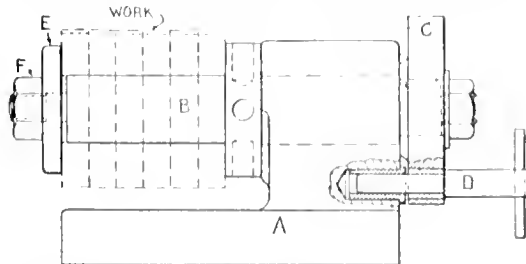

FIGS. 1 AND 2. FIXTURE FOR CUTTING SPANNER SLOTS IN CIRCULAR NUTS, ETC.

MILLING FIXTURES FOR SMALL JOBS

By W. G.

TWO simple milling fixtures are shown in the accompanying illustrations, Figs.

each pair of nuts, a spring being fitted on each stud for the purpose of making the clamp plate follow up the nut when slackening back so that the work can be easily removed and replaced.

GRADUATING A GAUGE IN THE LATHE

By E. T. Spidy.

SOME years ago during his apprenticeship the writer had occasion to graduate a gauge in course of making, and conceived the idea of using a tool lathe for

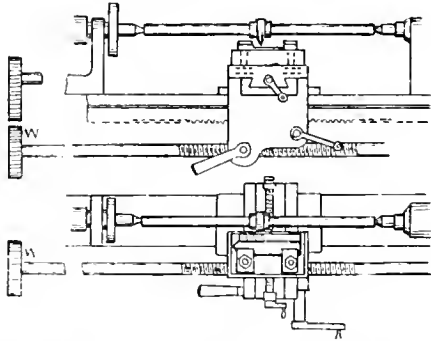

GRADUATING A GAUGE IN THE LATHE.

the purpose, no special appliances being available for the work. The manner in which it was accomplished is shown in the sketch. An old milling cutter was specially ground to a point and mounted between the lathe centres, being prevented from rotating by a dog (not shown) on the shaft. The top tool clamp was then removed and the gauge clamped in place. With the guide screw securely locked in the split nut and with a lead screw having four threads per inch, it was possible to secure very accurate spacings by turning the wheel W through a quarter of a turn, causing the carriage to move along 1-16th in. with a considerable degree of accuracy. The actual marking of the graduation made it necessary to run the cross carriage in and out each time, but where one's tools were limited, the arrangement described makes a good and accurate job.



RELIABILITY OF PRODUCT

AMONG the cardinal virtues which underlie all business and manufacture, there is absolutely nothing which can compare in importance with that of reliability, because, to say that a certain article, machine or man is reliable, is to pass the highest compliment known to mechanical art. Lots of quite surprising novelties whose interest and possibility were instantly recognized have passed into oblivion, not because they always failed, but that no real dependence could be placed upon them. Part of the conservatism and prejudice met with, acting adversely to the introduction of the new, is due to past unreliability of equally promising schemes.

Argument from first principles will not do; there must be conviction that uniform results may be expected. Trying out is one way of phrasing the search for dependable results; guarantees are another means of convincing a customer. There is merit, but little value, in a single piece of steel with extraordinary virtues; if, however, it can be duplicated in large quantities, the desired ends, uniformity and reliability, are secured.

The average engineer is a sceptical person, hard to convince, slow to introduce the new and abandon the old; he has experience of existing things, knows they are reliable, while the new must be tried out before it can prove successful. Nothing succeeds like success, but the cardinal feature of success is dependability. It is extremely galling, after one machine has been installed, to find its duplicate troublesome, hence the need for a manufacturer to take real pains to secure uniformity of product. Ingenuity, good design, attractive features, may all be sacrificed by default in material or workmanship, or the feeling that near enough is good enough. It isn't. The first-class maker incurs large expenses in testing his product to secure reliability, to insure real duplication, to locate and remedy trouble and error before despatching the goods. Such methods secure that easily forfeited but coveted distinction—reputation. A house of repute may have its products flagrantly copied and still suffer little by such competition. Unless the competitor has the same conscientious scruples as the originator (obviously he hasn't), then his product must be inferior in what counts in the long run above all else—reliability.

To attain the reputation enjoyed by some of the progressive firms of to-day means constant vigilance and unremitting watchfulness that the material, workmanship, and other minor but equally essential things do not suffer. It is in one sense easier to build a reputation than to hold it, easier still to live on the reputation of the past slowly sinking into decay, than it is to rest unsatisfied, and while maintaining vital characteristics, to continue the upward climb of progress. Eternal vigilance is the price of most things worth having, and in the business of engineering it is exacted to the uttermost. When a first-class article is bought from a house of reputation, this quality is included, but not invoiced.

It seems simple enough to build a standardized machine in quantities; good methods and practice economically sound are fairly well known; staff and workmen competent for their various duties can be hired at market rates, but more is involved even than method, men and organization; there is always that administrative supervision which counts for so much. Reliability will not take care of itself—it depends upon too many factors; hesitation to scrap the imperfect is a common failing, and the invasion of slovenliness is difficult to check.

In a human sense a reliable man is a dependable man, always there with his job on hand at the right moment, indicating initiative, character and backbone. Such men are not common. The raising of such men depends as much upon what the management does as upon any system of reward. There must perforce be the native material to begin with, but one indication and measure of the value of any firm is in the type of man they train. Anyhow, it is difficult to see how reliable products can be built without reliable men.

If the material turned out has character, it is equally certain that the builder thereof has character too. In such-wise, reliability has a double effect, and its reaction from machine to man and conversely is worth consideration. Dishonest and slipshod methods of workmanship have a human no less than a material aspect. Reliability is itself a complex quality built up of numerous but quite ordinary virtues, co-ordinated, however, into a combination whose value is not easily assessed. Vigilance is its price, involving unremitting labor and thought, but its reward is sure.



LUMBER ORDERS FOR B. C.

LARGE contracts for lumber, aggregating 16,500,000 feet, exclusive of an open order for all the clear spruce available, has been placed by the Imperial Government with British Columbia mills.

Victoria, Vancouver and Chemainus mills will supply two cargoes of railroad ties ordered by the British Admiralty through a San Francisco house, this order approximating 7,000,000 feet.

Another order has been placed direct by the British Government for 3,500,000 feet of lumber, 2,000,000 feet of which will be clear fir, the remainder being heavy timbers, which will be shipped through to St. John, N.B., and handled from that point by British transports. In addition, a third order has been placed by the Admiralty for 500,000 box shooks, approximating 6,000,000 feet, this order being divided between the Brunette Saw Mills and B. C. Manufacturing Co., of New Westminster; J. Hendry & Co., Vancouver; Lemon & Gounason, Victoria, and the Cameron Mill Company, also of this city.

The total output of clear spruce for airplane manufacture and shipments are being sent overseas as fast as the mills can supply this class of lumber. The new orders are welcomed by the mills, not from the profit standpoint, as the prices are about as low as it is possible to handle the business, but because the placing of these contracts with the British Columbia mills will assure steady operation for some months to come.



NEW BRUNSWICK MINERALS

THE minerals of New Brunswick, developed and undeveloped, cover a considerable range. They include an anti-mony deposit at Lake George, which has recently been taken over by the Northern Antimony Smelting Company, with a capitalization of \$2,000,000; bituminous coal deposits (estimated to contain fifteen million tons); iron, gypsum, oil shales, manganese, graphite, tungsten, molybdenite, copper, lead, zinc, galena, barytes, infusorial earth, black, grey and red granites, freestone, sandstones, and other minerals, which offer a very attractive field for investment. A discovery of a rich bed of galena ore was recently made at Maple Grove, York County, by W. H. Griffin, a provincial game guide. Two veins of 22 feet and 12 feet respectively have been uncovered. Ontario parties have secured an option of the mine.

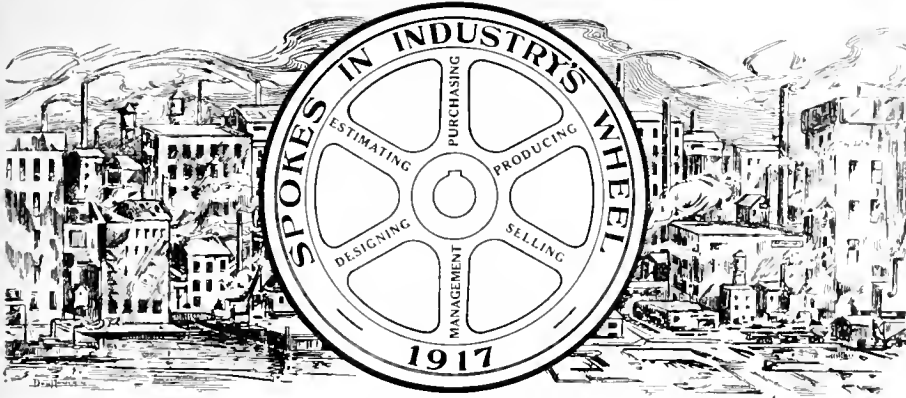

The constitution of industrial enterprise is largely departmental—"spokes in a wheel." This series of articles has for its object the featuring in a racy, interesting and instructive fashion, the training, experience and achievement of those who to-day are transmitting, effectively, energy in their capacity as "spokes in the wheels" of our metal-working establishments.

D. M. MEDCALF

WITH the new Steam Boilers Act, which became effective throughout the Province of Ontario on July 1, 1913, there arose the necessity to establish a fully equipped bureau of inspection, and, in casting about for a responsible head for same, D. M. Medcalf, who, during the previous eight years had been provincial inspector of boilers and operating machinery installed in our public institutions, received the appointment. Constituting what is officially known as the Steam Boiler Section, Trades and Labor Branch, Department of Public Works, Province of Ontario, and occupying a suite of offices in the Parliament Buildings, Queen's Park, Toronto, we find a staff personnel of one chief inspector—Mr. Medcalf, six inspectors, one stenographer, and one clerk and stenographer; a by no means formidable aggregation when account is taken of the onerous nature of the duties imposed, and of the myriad industrial and power plants, public institutions and office buildings, portable and semi-portable outfits, etc., into the activities, of which steam boilers, steam piping and the numerous auxiliaries of the latter, enter.

Mr. Medcalf was born in Toronto, March 19, 1873, of Canadian parentage, receiving his education in the public schools of his native city. At the age of sixteen—like most boys, he found school life a trifle slow and unromantic, having figured that by donning overalls and applying his then acquired education, he could not only continue to learn, and to perhaps greater ultimate advantage, but what was of equal importance, begin to earn something for those on whom he had been so long dependent, besides securing a modicum of pocket money for himself. We find him, therefore, in 1889 an apprentice machinist in the Don Foundry & Machine Shop, Toronto, formerly owned and operated by his father, the late Alfred Medcalf. Later, he transferred his services to the Polson Iron Works as a machinist improver,

and completed his five years' apprenticeship in that capacity.

It is generally believed, and shall we say there is all truth and little fiction in the statement that, making due allowance for the fact of other and perhaps farther away fields looking greener, newly full-fledged mechanics, however expert, must flee the apprenticeship nest



D. M. MEDCALF.

in order to secure a cash rating commensurate with their ability. Be that as it may although all of us are unanimous in our opinion, we find young Medcalf employed as a journeyman machinist first with the John Inglis Co., Strachan Avenue, Toronto, and some time later with the Northey Pump Works, also of Toronto. We next find him in a like capacity employed for stated periods in the Vulcan Iron Works and C. P. R. Shops, Winnipeg, Man. The lust for travel, no less the quest for experience, engendered by the journey to

and sojourn in Winnipeg, may be taken as ample reason and justification for our hearing of his having crossed the border and taken up his abode for what ultimately proved to be for a period of six years' duration.

During this time he was successively employed as a mechanic with the Lake Erie Engineering Works, Buffalo, N.Y.; Baldwin Locomotive Works, Philadelphia, Pa.; Northern Pacific Railway Shops, Brainard, Minnesota; and Illinois Central Railway Shops, Chicago.

Mr. Medcalf, in December, 1909, represented the Province of Ontario at a conference of Provincial Boiler Inspectors held at Regina, Sask. There, rules and regulations were drafted and subsequently adopted by the Provinces of Alberta, Saskatchewan, and Ontario. Since then, steps have been taken towards a further development of uniformity in provincial boiler construction and inspection rules, and it is reasonable to assume that at no distant date all of the provinces of this Dominion will see it to be advantageous to fall into line. In what has already been accomplished, and in the coming consummation of a Dominion-wide code of boiler rules and regulations, the personal effort and untiring energy of Mr. Medcalf will be found to have been in large measure responsible.

Mr. Medcalf married Ella Clemens, of Preston, Ont., in the year 1900, his family consisting of two, known in the writer's native country as a "Do'e's Cleeekin." His recreations are motoring and bowling—when opportunity permits, although from what we know of the gentleman, his recreations—or more properly speaking, his hobbies—are largely in the realm of boilerdom. In a word, his new position, onerous as are its duties, seems to serve admirably, both as a life business and an all-absorbing recreation or hobby. Due to holding a Government appointment, he has had to abjure politics, not an over-hard undertaking on the part of the engineering fraternity, as was here remarked on a former occasion. In matters of religion he is Methodist, and, according to his own statement, which we can vouch for—the statement only, of course—he is regular and dutiful in his attendance at services and in the activities respectively of the Eaton Memorial Church, Toronto. We may not omit, however, to state that Mr. Medcalf has not altogether overlooked his fraternal obligations, expression being given same by his A.F. & A.M. membership. His residence is 51 Parkwood Avenue, Toronto.

Technical education, through the medium of specially established schools, or home study supplemented by technical books, trade and technical papers, finds in Mr. Medcalf a booster at once high grade and effective, a circumstance due, we should say, to the fact that through its instrumentality and ramifications he owes perhaps as much as to anything else his present appointment, as well as the ability with which he directs and supervises its many-sided activities.

**BOILER INSPECTION REPORT,
DEPT. PUBLIC WORKS
PROVINCE OF ONTARIO**

THE enormous increase in the cost of steel since the outbreak of the war has affected to a considerable extent the manufacture of boilers in Ontario as elsewhere by reason of the necessary increase in the selling price. This increased cost of new boilers has created a great demand for secondhand boilers—not altogether on account of cheapness for high prices are being paid—but by reason of their being more or less immediately available. Many old and discarded boilers which in normal times would be sold as scrap or left rusting in vacant places around our factories have been cleaned and painted and put on the market for sale by boiler dealers, a circumstance calling for extra vigilance as far as inspection goes.

A slight alteration has been made in the Steam Boiler Act, section 2, subsection D, which formerly read:—

“A portable boiler rated at 25 horse power or under, or a boiler used exclusively for horticultural or agricultural purposes.” The words “rated at 25 horse power or under” have been omitted. This change in the Act gives jurisdiction over portable boilers used in public places in conjunction with contractors equipment etc. Boilers of this kind formerly were not built from registered designs and were exempt from provincial laws. The fact that those boilers are often used in close proximity to hundreds of people is good reason why their designs should be of the most approved type, and also why they ought to be inspected annually.

It will be noted from the list of inspections that in addition to boilers, a number of air tanks have been examined during the past year. This inspection work was made at the request of the owners of these vessels and the customary fee of \$5.00 per tank was paid by them. The safe working pressures were determined from the rules governing the construction of steam boilers, and the same certificates as issued for used boilers were made out for these vessels.

During the past year ten boilers have been inspected for British Columbia. Arrangements were made during 1915, whereby the inspection of all stationary boilers built in Ontario for British Columbia would be carried out by Inspectors of this branch. Some trouble was experienced heretofore by manufacturers on account of their boilers being re-examined on arrival at their destination, and sometimes the safe working pressure was reduced on account of defects in the workmanship. The boilers examined during the past year have been accepted by the British Columbia authorities without being penalized in any way. During normal times the number of boilers built in Ontario for British Columbia would of course be much more than last year's total.

For some time past, and more especially since the fatal steam valve explosion at the Greer Foundry, Toronto, the work of surveying and registering

high pressure pipe lines has been undertaken. The accompanying data summarises the inspection work carried out during the year ended October 31, 1916.

Drawings and Specifications Surveyed and Registered.

Boilers	97
Boiler fittings	78
Pipe lines	31
Pressure tanks	6
Digestors	4
Superheaters	1
Drawings returned to manufacturers for correction	17
Registered boilers inspected during construction	313
Plates examined	1415
Plates rejected	16
Registered boilers inspected by Insurance companies in the United States	35
Registered boilers inspected by Insurance companies in Great Britain	4
New boilers inspected during construction for British Columbia	10
Used boilers inspected in Ontario	612
Air tanks inspected in Ontario	21
Steam drums inspected in Ontario	4
Steam plans inspected in Ontario	1
Pipe lines inspected in Ontario	4
Used boilers inspected and condemned	23
Class “A” certificates issued for new boilers	348
Class “B” certificates issued for used boilers	527
Heating certificates issued ..	220



BRITAIN'S MUNITIONS OUTPUT

THE remarkable increase in Great Britain's output of munitions is dealt with in an official statement just issued, which says:

“From time to time indications have been given of the enormous growth in the production of munitions in this country during the past 18 months. The supply of both guns and projectiles is increasing, as will be seen by the following figures, in which, from its importance in modern methods of warfare, artillery ammunition deserves first place. Taking as a basis for calculation, the average weekly production from the beginning of the war up to the end of June, 1915, the figures show the following wonderful rate of progress:

	(a)	(b)	(c)	(d)
18-pdr.	1	6½	17½	43
Field Howitzers (4.5 in.)	1	8	27	
Medium guns and howitzers	1	7½	34½	66
Heavy Howitzers (above 6 in.) ..	1	22	94	303
(a) Weekly average at the end of June, 1915.				
(b) Weekly average from July 1, 1915, to June 30, 1916.				
(c) Week ending July 1, 1916.				
(d) Week ending November 25, 1916.				

“The improvement may be illustrated in a different way. We are now manufacturing in 8½ days the number of 75 m. m. shells which we were producing during the first year of the war—August, 1914 to August, 1915. The same

quantity of projectiles for field howitzers is being supplied in eight days; that of projectiles for medium guns and howitzers in 5½ days, and that of projectiles for heavy guns and howitzers in a little more than one day. The number of shells completed or filled during the week of November 19-26 this year exceeded by about 30 per cent. the stock of munitions, held in reserve at the outbreak of hostilities.

Manufacture of Guns

“Dealing with guns in the same way, it is found that, representing the number of guns manufactured during the first year of war, the following increase has been secured:

	1st year	2nd year	July 31 to Nov. 29, 1916 (4 months)
18-pdr.	100	240	45
4.5 in.	100	654	104
Medium (60-pdr. and 6 in.)	100	1,848	1,200
Heavy (over 6 in.)	100	623	363

“The manufacture of 18-pdr. guns has had to be slackened during the last period, the equipment of the British army in light field pieces being approximately complete.

“If the average monthly production of guns of all calibre be considered, a splendid development can be observed on comparing the results of the first year with those of the second period of 1916, as is seen from the following table:

	Monthly average for first year	Production during the five weeks ending Dec. 2, 1916
18-pdr.	100	128
Medium	100	4,100
Heavy	100	1,250

Large Increases Shown

“The improvement in the manufacture of machine guns, rifles, grenades and explosives has been equally satisfactory. If the total number of machine guns delivered to the army during the first year of the war be represented by 100, the total could be represented by 1,250 at the end of the second year and by 2,000 on December 2, 1916. Taking as a base the weekly production of machine guns in November, 1915, and representing it by 100, the corresponding figure for the weekly production in November, 1916, would be 410.

“The increase in the manufacture of explosives has been extremely rapid. For every ton of explosive employed in September, 1914, 350 tons were employed in July, 1915, and from 11,000 to 12,000 tons in July, 1916.

“Between May, 1915, and May, 1916, there was a 38-fold increase in bombs and a 150-fold increase in the weight of the contained explosive.”



Toronto, Ont.—At a meeting of the Board of Trade held recently, John G. Kent was elected president, C. A. Bogert, of the Dominion Bank, vice-president; Charles Marriott, of G. Goulding & Sons, second vice-president, and W. H. Alderson, of the Gutta Percha & Rubber Co., was elected treasurer.

PASSING OF A LEADING CANADIAN MANUFACTURER

IN the death of Hugh McCulloch, president of the Goldie & McCulloch Co., who passed away at his home, Sorn House, on January 8, Galt has lost one of her leading and most highly esteemed citizens.

Mr. McCulloch, who was in his 61st year, was born in Galt on September 7, 1856. He received his education at the Whitby Grammar School and Upper Canada College, on completion of which he served an apprenticeship in the Goldie & McCulloch shops, his father, Hugh McCulloch, sen., being then president of the company. Practically his whole life has been spent in furthering the interests of the firm in which he was a member, and the industrial interests of the community in which he lived.

When the company was incorporated in 1891 and took over the business of the firm of Goldie & McCulloch, he was appointed secretary-treasurer, which position he held until elected vice-president in 1898, assuming the presidency on the death of his father in September, 1910. Mr. McCulloch was closely associated with various other manufacturing concerns in Galt, having been at the time of his death vice-president of the Galt Malleable Iron Co., also of the Galt Art Metal Co., a director of the Gore Mutual Fire Insurance Co., also for many years a director of the Galt Gas Light Co.

In religion Mr. McCulloch was an honored member of Knox Presbyterian Church. His principal amusements were fishing, golf and motoring. Sorn House, his home, constitutes in itself and location one of Galt's beauty spots. There survive him a sorrowing wife, one brother, R. O. McCulloch, of Galt, and a sister, Mrs. Chas. A. Shearson, of Toronto.

The funeral, which took place at Galt on Wednesday, January 10, was very largely attended, the number of local mourners being materially supplemented by friends and business associates from other places.

AUSTRALIAN RESTRICTION ON CANADIAN SHIPPING

THE Canadian Government is now negotiating with the Australian authorities with regard to loadline restrictions at present imposed on Canadian ships trading to ports of the Commonwealth. The matter has become of immediate importance in connection with the construction on the Pacific Coast of wooden ships designed to carry lumber from Canada to the Antipodes. Partly as a result of subsidies by the British Columbia Government, there has grown up in the Pacific Province a wooden shipbuilding industry of considerable proportions. Numbers of vessels of from 1,500 to 3,000 tons are being turned out, being designed as four and five masted schooners with auxiliary Diesel oil engines.

These vessels will enter into competition with American-built ships, which trade to Australia and which have hitherto carried much Canadian lumber as well as pitchpine to Australia and New Zealand. They are under a great disadvantage, however, in that all British vessels trading into Australian ports are subject to loadline restrictions which would considerably reduce their carrying capacity as compared with American vessels to which restrictions would not apply. The Marine Department has had the matter taken up with the Australian Government and it is expected the discrimination which exists under the present regulations will be done away with

ELECTRICALLY-OPERATED GANTRY AT THOR IRON WORKS, TORONTO

AT the shipbuilding plant of the Thor Iron Works, located at the foot of Bathurst Street, Toronto, an electrically-operated gantry has recently been constructed over the shipway, which greatly facilitates the shipbuilding operations being carried on there.

The gantry, the general features of which are shown in the illustration, has a capacity of 20 tons, a span of 60 feet, and one outboard arm of 15 ft. in length. It has a clear lift of 56 ft. from hook to rail; is of double girder type construction, with operating cage suspended from trolley. The speeds and scope of service are as follows:—Hoist, 30 ft. per minute; travel, 250 ft. per min.; and traverse, 200 ft. per min. The hoist motor is of 35-h.p.; travel motor, 35-h.p.; and traverse motor, 7½ h.p., all operating on 500 volts, direct current. The gantry is fitted with electric brakes in addition to mechanically operated brakes, and all the gears are of cast steel. Electric light clusters are distributed about the gantry, so that night work can be carried out without inconvenience or delay.

In addition to a view of the gantry, the photograph shows construction progress on the first of two steel ocean-going freighters, orders for which were received a few months ago.

SOME makers of windmills estimate that a wind of 16 miles an hour may be expected for eight hours per day on the average for every day in the year. This does not mean that such a wind can be relied upon every day in the year, of course, but that the average wind all the year round would equal 16 miles an hour for eight hours every day.

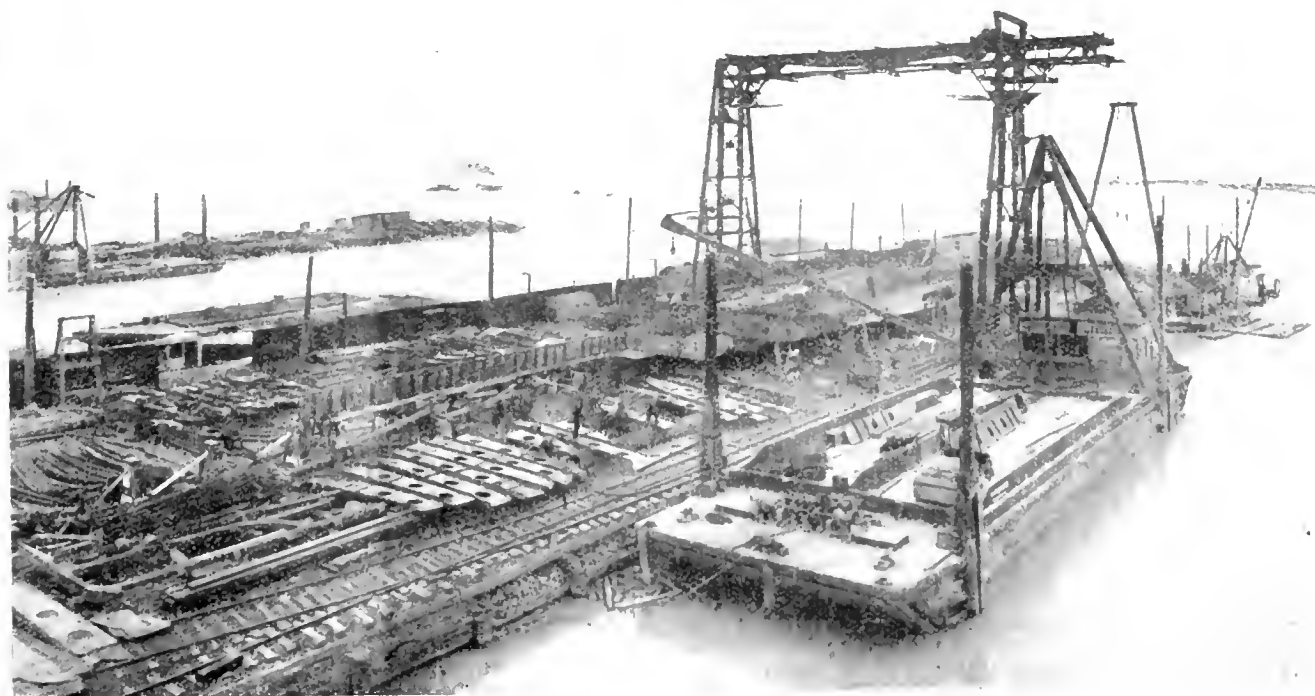

ELECTRICALLY OPERATED GANTRY AND SHIPBUILDING BERTH AT THOR IRON WORKS, TORONTO

PROGRESS IN NEW EQUIPMENT

A Record of New and Improved Machinery and Accessories for the Machine, Pattern, Boiler and Blacksmith Shops, Planing Mill, Foundry and Power Plant

PRESSURE-REDUCING VALVE

THE sectional view shows a Foster patent reducing valve embodying improvements which have for their object quieter and smoother action and more gradual and uniform passage of the fluid from the high to the low-pressure side of the valve. In the Foster reducing valve the pressure desired to be delivered to the heating or other system is set and automatically governed by an adjustable spring acting through a system of toggle levers on a diaphragm in the valve chamber. This diaphragm has a spindle passed through it; one end of the latter is engaged by the toggle levers, while the other end

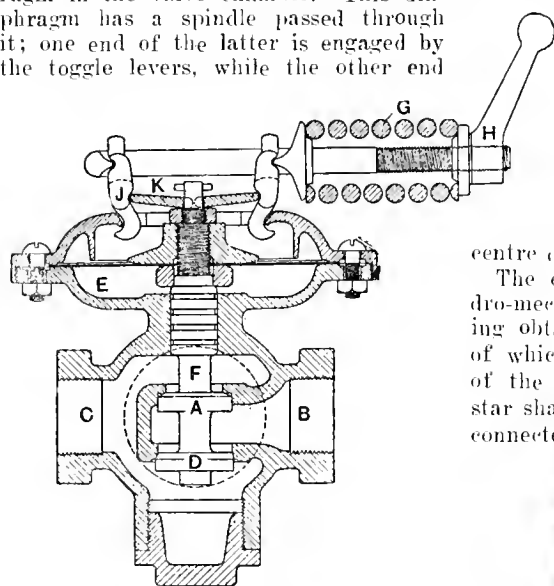

PRESSURE REDUCING VALVE.

carries a double-beat valve having two seatings in the valve body through which steam or any fluid under pressure is passed. The invention consists essentially in forming one of the double-beat valves as a sliding piston valve, whilst the other valve of the pair is of the usual bevel-edged type.

Referring to the illustration, B designates the inlet and C the outlet of the valve, E the diaphragm, F the valve stem, A D the double-beat valves, G the adjustable spring, H a nut on the screwed portion of the spring rod for regulating the delivery pressure, and J toggle levers acting in combination with links K. The valve A of the double-beat valves is made in the form of a sliding piston valve as shown, while the other valve D of the pair is of the usual bevel-edged lift type, by which means high-pressure steam is enabled to pass first through the lift valve D whilst the piston valve A remains closed until the delivery pressure is reduced to such a point that the piston valve A is also opened and the steam or fluid passes through both the double-beat valves in

a greater volume. It is claimed that "wire drawing" or cutting action on the valve face and seats is thereby prevented. Sir W. H. Bailey & Co., Salford, England, are makers of the foregoing apparatus.

HYDRAULIC SHRINKER FOR AUTOMOBILE RIMS

A COMBINED hydraulic and mechanical shrinking press for the exact sizing of rims for automobile wheels has been built by the Metalwood Mfg. Co., Detroit, Mich. The accompanying engraving shows the mechanism, which is practically all on the rear side of the main frame, the front or operating side simply having a circular opening surrounding the eight pressure dies which operate radially toward the centre of the main frame.

The operation of the machine is hydro-mechanical, the prime movement being obtained from a ram, the cylinder of which is supported on the rear legs of the machine. The crosshead is of star shape, each of the eight arms being connected by a compression link to the

several toggle joints located around the outer edge of the main frame.

The closure of the dies is regulated by the handwheel in the foreground of the picture, which by means of worm gearing causes a nut to advance or recede on the end of the ram, the nut making stop contact with the main frame and regulating the stroke of the ram accordingly. The weight of the crosshead and ram is carried on the horizontal tension members, suitable babbitt-lined bosses being provided for this purpose.

The ram is of hard semi-steel, finely polished and packed by a reeding nut, U-type chrome leather packing being fitted to both the main ram and the ram in the pull-back cylinder. The machine is designed to operate at pressures between 1,000 and 2,000 lbs. per sq. in. developing 675 tons total pressure on the dies with the former pressure. Steel castings are used freely, and carbon steel for the dies.

HEAVY TURRET LATHE

FOR some time the Corbet Foundry & Machine Co., Owen Sound, Ont., have been building heavy turret lathes espe-

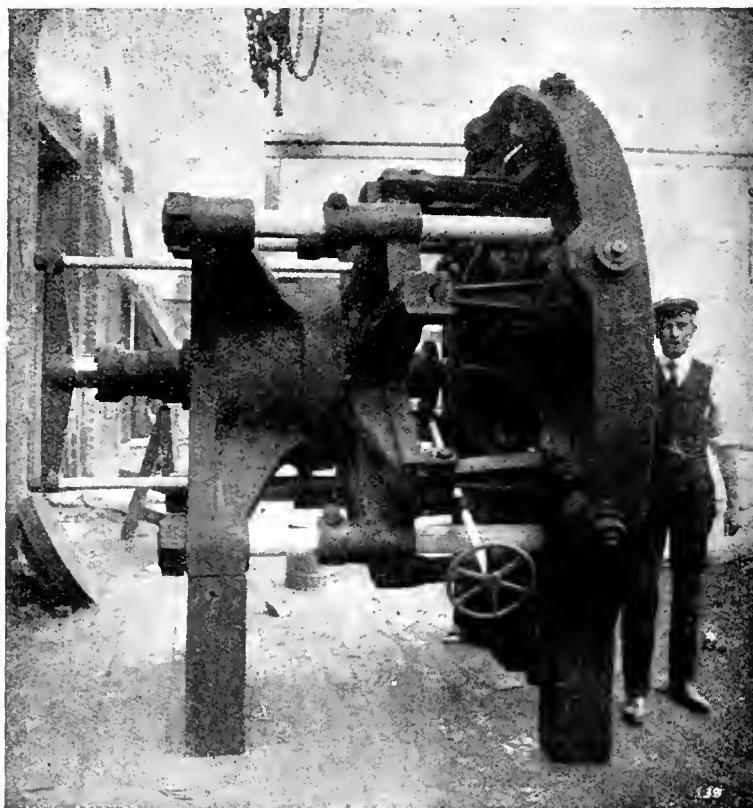

HYDRAULIC TOGGLE PRESS FOR SHRINKING RIMS OF AUTOMOBILE WHEELS.

cially suited for munition work, and their latest design, based on extensive experience is shown in the accompanying illustration. Exceptionally heavy proportions have been adopted throughout, the driving pulley being 14 in. dia. x 8 in. face with main gears of 7 to 1 ratio.

The hollow spindle is made to accommodate shell forgings of 6 in. size and under, the main bearing being suffi-

or surplus stock has been drilled out and removed, and is operated by a motor which can be used on an ordinary lighting circuit.

The chief feature about the machine is the employment of cutters having a multiple thread helix, the section of the thread being that of a ratchet or buttress screw, which, when rotated at high speed, shears the material off the work. With the pitch of the cutting threads in

at the lower end of main spindle, and require no feed screws, slides or vises in which to hold or control the work in operation.

The machine is the product of the Anderson Die Machine Co., Bridgeport, Conn., and is distributed by R. E. T. Pringle Co., Toronto, being regularly equipped with motor for any desired voltage, cord and plug, tool rack and twelve selected cutters. Weight with motor 55 lbs.

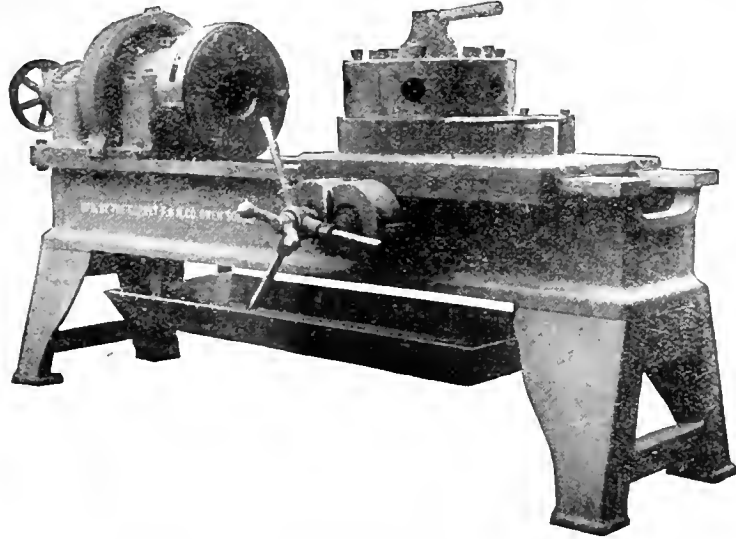

HEAVY TURRET LATHE FOR MUNITIONS PRODUCTION

ciently large to dispense with outer steady bearing. Machine cut steel gears are used throughout. An automatic chuck operated by hand wheel at end of headstock provides ample gripping power.

Turret proportions are very liberal and feed is obtained from a belt-driven worm shaft at the back of the bed, meshing with a worm wheel on the outer end of the feed pinion shaft. Hand-feed is provided through a three spoke spider with clutch gear.

These machines are equipped complete with chuck, countershaft, and controlling clutch, the net weight of the lathe being 5,200 lbs.

the proper direction, the work is drawn down and made to hug the platen or table assisting greatly in controlling the work in hand. This action also carries the chips down so as to have the line marked out on the blank visible at all times.

The machine consists of a main frame carrying the vertical cutter spindle, the driving shaft being disposed at right angles to the main spindle which it drives through spiral gearing. The motor is especially wound to take care of the intermittent loads and is completely protected from injury by chips or dust.

The work table is adjustable, and is set at right angles to the spindle, the desired amount of clearance being obtained through the use of tapered cutters, which with a level table give uniform clearance on all sides of the die no matter from what direction the work is applied to the cutter. One benefit of this feature is that when grinding dies in use, the opening is enlarged uniformly without distortion due to unequal clearance angles.

All the cutters have plain shanks 1/4 in. dia. and are made straight, tapered, and reverse taper, from 1/8 in. to 5/16 in. diameter. They are held in a draw-down collet which is closed by a spring

NEW VERNIER HEIGHT GAUGE

A NEW vernier height gauge, having improved attachments for greater efficiency, has been brought out by the L. S. Starrett Co., of Athol, Mass. Tool-makers and machinists who are familiar with the Starrett vernier caliper will find the new tool of similar quality.

The bar is 10 in. long, graduated to read by means of vernier of an inch on measurements up to 8 in. high. The base is 2 3/4 in. long by 1 in. wide, hardened to give long wear and recessed in the bottom and ground square with the bar, giving perfect accuracy. An extension is furnished for the movable bar, which allows reverse measurements to be taken from the bottom or top side of the jaw.

An attachment to permit measure-

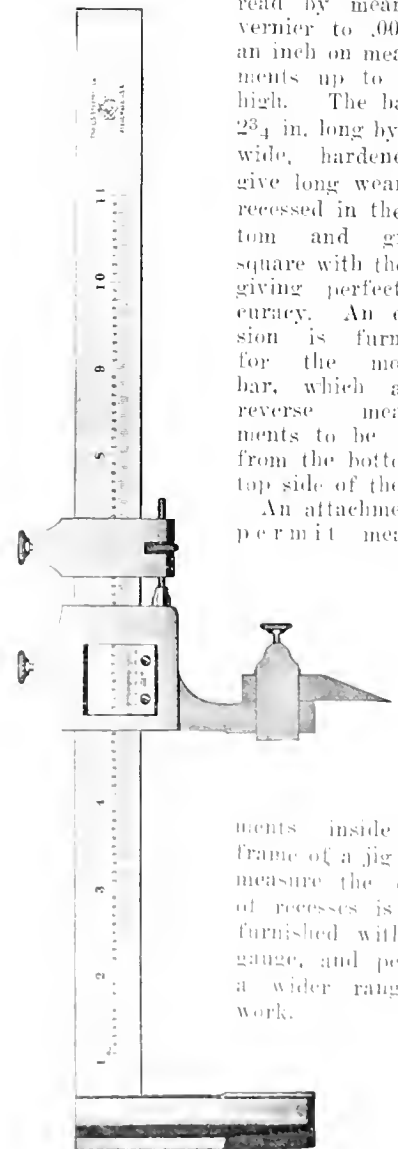

VERNIER HEIGHT GAUGE WITH ATTACHMENT

ments inside the frame of a jig or to measure the depth of recesses is also furnished with the gauge, and permits a wider range of work.

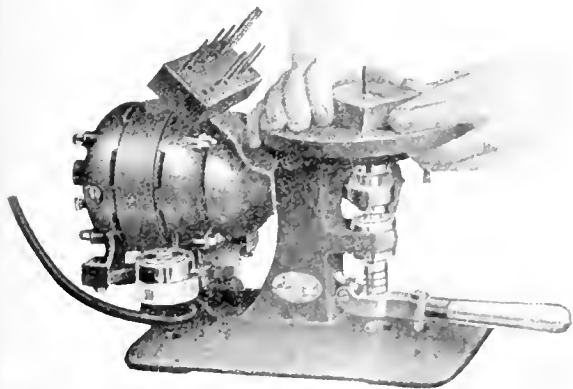

GEAR DRIVEN DIE FORMING MACHINE WITH HELICAL CUTTERS MAKING CONTINUOUS CUT ON WORK.

DIE FORMING MACHINE WITH HELICAL CUTTERS

THE machine illustrated herewith is designed specially for finishing blanking dies and similar work, after the core

MINING IN ALBERTA DURING 1916 COMPLETE mining statistics for the Province of Alberta for the year 1916 are not yet complete and will not be available before the end of February.

The total output for the year will, it is estimated, be between 4,250,000 and 4,500,000 tons. This shows an increase of approximately 1,000,000 tons over the output for the year 1915. A much larger amount of coal is being shipped from Alberta into the Province of Manitoba than formerly. During the first three months of last year, the mines, particularly in the lignite field worked more steadily than is usual at that time of year owing to the extreme cold weather experienced. During these months, however, the output in the Drumbheller district was seriously handicapped by a scarcity of railway cars. The output has also been interfered with to a certain extent by a shortage of labor, although during the last few months this has materially improved.

From January first to December fifteenth, 44 new mines were opened and 52 abandoned in the province, the number at present in operation being 248. During the same period, 18 fatal accidents occurred as compared with 18 for the whole of the year 1915, also 76 non-fatal, as compared with 66 non-fatal accidents during the year 1915.

A mine rescue car has been installed in the Drumbheller field during the year, there being now three mine rescue cars in operation as follows:—One in the Crow's Nest Pass, one in the Canmore and Bankhead district and one in the Drumbheller district; there are also five mine rescue stations placed as follows: Three in the Lethbridge district, one in the Brazeau, and one in the Jasper

Park district. The superintendent of each of these stations devotes a considerable portion of his time to instruction in first aid work.

On July 1, 1916, competitions in mine rescue and first aid work were held at Coleman. Thirty-two certificates of competency in mine rescue work were granted during the year, making a total of 261 certificates issued since the establishment of mine rescue stations in the province. Provision has also been made for the payment of men doing mine rescue training at the rate of 50 cents per hour. Two teams are kept at each mine, each team being expected to undergo at least one training each month. A large number of mines in the province are adopting the use of electric cap lamps with very satisfactory results. A number of electrical coal cutting machines have been installed in different mines during the year.

Seven of the new mines which were opened during the year are located in the Grade Prairie district about 400

miles northwest of Edmonton and are supplying coal to the settlers there. During the year two copper mines were opened west of Banff, on the main line of the Canadian Pacific Railway. These mines are situated near Eldon. Only a small amount of development work was done, however, and they are now abandoned. On the property owned by the Alberta Copper Co., there is a vein between 5 and 6 ft. in thickness, on which a tunnel is being driven for a distance of 154 feet, and on the property owned by the Calgary Copper Co., there is a vein 12 ft. in thickness.



NOVA SCOTIA STEEL & COAL CO.

A MEETING of the directors of the Nova Scotia Steel & Coal Co. was held at New Glasgow, N.S., on January 9.



PEACE PROPOSALS—FROM "HUMOR IN THE ROYAL NAVY."

Those present were: G. S. Campbell and J. Walter Allison, of Halifax; W. H. Chase, Wolfville; Lorne C. Webster, Montreal; R. E. Chambers, New Glasgow; W. D. Ross, Toronto, vice-president; and Col. Cantley, New Glasgow, president.

It was shown that the output of the New Glasgow plant for the calendar year ended December 31 last, was more than 60 per cent. greater than that of 1915, while the orders on hand are sufficient to keep the plant fully occupied for a large portion of the current year, even at the increased rate of production prevailing in 1916.

It was also shown that their subsidiary, the Eastern Car Co., had received a further order for three thousand cars for Europe. These cars are to be delivered at a Canadian port, and, with other orders now on hand, will be sufficient to keep the car plant fully occupied for the whole of 1917.

CANADIAN REVENUE FOR NINE MONTHS

THE financial statement of Canada for the nine months of the fiscal year ended with December shows a total revenue of \$166,856,349, as compared with \$122,027,821 in the corresponding period. In the month of December alone the revenue amounted to \$21,943,775 an increase of over four millions.

Expenditures on the war in the nine months aggregated \$170,229,748, a growth of eighty-five millions. In the same period domestic expenditures on consolidated account totalled \$81,696,505, an increase of seven millions. On the present basis of capital and consolidated outlay compared with the revenues there will be a surplus, apart from the war expenditure, of about sixty millions.

The Customs Department is the principal contributor to the aggregate revenue, furnishing \$97,332,210 in the nine months, which is an augmentation of \$28,000,000. Excise brought in eighteen millions, public works almost twenty millions, and post-office twenty millions. At the end of December the net debt, increased by interest charges, stood at \$722,111,449, a growth of about \$200,000,000 in the year.



COMPANIES ACT INCORPORATED

The number of companies incorporated under the Companies Act, Canada during the fiscal year ending March 31, 1916, was 534, with a total capitalization of \$157,342,800, and the number of existing companies to which Supplementary Letters Patent were issued was 71, of which 28 increased their capital stock \$68,996,000, and 11 decreased same \$4,811,700. The remaining 32 were granted Supplementary Letters Patent for various objects, such as changing names, extending powers, etc., making a total of 605 charters and supplementaries issued during the year, an increase of 59 as compared with the previous year. The total capitalization of new companies and the increased capital of existing companies amounted to \$221,527,100.



The Reason Why.—An English militant crusader strolled into a barn where a young man was milking a cow. With a snort, she asked: "How is it that you are not at the front, young man?" "Because, ma'am," answered the milker, "there ain't no milk at that end."

The MacLean Publishing Company

LIMITED

(ESTABLISHED 1888)

JOHN BAYNE MACLEAN - - - - - President
 H. T. HUNTER - - - - - Vice-President
 H. V. TYRRELL - - - - - General Manager

PUBLISHERS OF

CANADIAN MACHINERY

AND MANUFACTURING NEWS

A weekly newspaper devoted to the machinery and manufacturing interests.

PETER BAIN, M.E., Editor. B. G. NEWTON, Manager.
 Associate Editors.

A. G. WEBSTER, J. M. WILSON, J. H. RODGERS.

Office of Publication, 143-153 University Avenue, Toronto, Ont.

Vol. XVII. JANUARY 18, 1917 No 3.

A GLIMPSE OF POST-WAR TRADE EFFORT

THE cancellation of Allied munitions orders in the United States, and the aggressive bidding of Hadfields Ltd., Sheffield, England, for American naval shell contracts should not pass without the careful consideration of every Canadian manufacturer, and particularly those who have received the benefit of orders which have been directly or indirectly the result of war conditions. In the first place the cancellation of British shell orders in the United States is an indication of the manner in which production has been increased in Great Britain, and what is true of finished shell output is equally so of the principal raw material—steel, entering therein. It may therefore be anticipated that contracts for the latter will show an accelerating tendency to shrink at an early date, if the process be not already operative.

In the second place the low bid of British makers on American shells illustrates emphatically that the cost of British and European production is on a much lower level than in the United States. Further, the great disparity between the delivery dates of Hadfields and their nearest domestic competitor seem to indisputably indicate greater efficiency, both as regards operative skill, and production equipment installed. Aside, however, from the special circumstances responsible for this glimpse into the future, putting two and two together is not much more simple than reaching the conclusion that happenings such as this have a bearing upon the industrial developments which may be expected to follow the war.

The manufacturer on this side of the Atlantic needs only ordinary foresight to see that the time is coming when there will be no more munition orders placed at prices made reckless by necessity, nor will there be a demand for other manufactures and natural products, meantime factors in the great military campaign at valuations which have upset normal standards. The end of the war will bring this change—if it does not come before, and in that same time there will be released for the manufacture of normal products all the vast and efficient machine which has been devoted to the taskmaster Mars since August, 1914. On what basis then will we be able to meet industrial Europe after the war?

The outlook is that the competition of old world manufacturers will be much keener than the past has ever known. In Canada and the United States' price-no-object

war buying, with general prosperity and high wages have put the cost of production on a much higher level than has ever been known. On the other hand in the Old World where the machinery of production has been greatly developed, immense armies will return to the usual walks of life, and labor will undoubtedly be plentiful and probably cheap. Costly production then in this country and cheap production in Britain and Europe can only lead to competition from across the seas, which will either result in a reduction of prices on this side or the purchase of foreign goods. Tariff adjustments may be made which will help the situation, but even so Canadian manufacturers would do well to mark the significance of such incidents as Hadfields' bidding on American shell contracts. For the benefit of our readers who may not have had the opportunity of perusing the details of the United States Navy Department armor piercing shell bids referred to, a brief comparative statement follows:

Hadfield's made bid for the delivery of 3,000 16-inch shells in sixteen months, at \$513 each. The next lowest bid was that of the Crucible Steel Co., which agreed to make 1,700 of these shells in twenty-six months at \$768 each. The highest American bid, that of the Midvale Steel Co., was \$900 each for 1,000 shells, to be delivered in twenty-four months.

The British company's bid was \$356 each for 4,500 of the 14-inch projectiles, to be delivered in eleven months. The next lowest bid, that of the Washington Steel & Ordnance Co., was \$500 each for 1,000 shells, to be delivered in twenty-two months. The Midvale Co. offered to make 5,600 of these shells in thirty months at \$550 each. The only other bid on 14-inch shells was that of the Crucible Steel Co., which offered to make 2,000 of them in forty-two months at \$543 each.



THE MUNITIONS LABOR SITUATION

CONSIDERABLE irritation is manifest as a result of the official campaign to stimulate recruiting for munitions production in our metal-working plants. Indefiniteness as to the class of labor wanted seems to be the "lost chord" in the various clarion calls issued to date, and while this in itself might have been foreseen and therefore avoided, it may be taken for granted, with the various individual experiences brought so very forcibly to their notice, that the Imperial Munitions Board, through its Department of Labor, will lose no time in switching its campaign effort to meet effectively its own insistent need and the offerings as well of those willing to meet same.

The undertaking to man our munitions plants to the limit of their capacity with either available male or female labor verges on the stupendous, besides being beset with difficulties apt to be overlooked, and perhaps minimized to the vanishing point even when known. Transportation troubles in the matter of fuel, steel, forgings, etc., have militated materially in recent weeks against the employment of the full quota of labor in many plants, and it may not be assuming too much to infer that the cases of individual inconvenience recorded have had the foregoing more than the Labor Department of the Imperial Munitions Board, to blame for the circumstances in which they found themselves. Now that our passenger train service has been materially restricted, and the locomotives and train crews have been transferred to supplement freight haulage and eliminate the congestion bogey, we may expect to see the scope of employment on munitions work of every description enlarged and complaints of disappointment by those willing to serve get beyond the range of possibility.

SELECTED MARKET QUOTATIONS

Being a record of prices current on raw and finished material entering into the manufacture of mechanical and general engineering products.

PIG IRON.

Grey forge, Pittsburgh ..	\$29 95
Lake Superior, charcoal, Chicago ..	31 75
Standard low phos., Philadelphia ..	53 60
Bessemer, Pittsburgh ..	35 50
Basic, Valley furnace ..	30 90
Montreal Toronto	
Middlesboro, No. 3 ..	40 00
Cleveland, No. 3 ..	38 00
Clarence, No. 3 ..	38 00
Hamilton ..	38 00
Victoria ..	38 00

FINISHED IRON AND STEEL.

Per lb. to Large Buyers Cents

Iron bars, base, Toronto ..	3.50
Steel bars, base, Toronto ..	3.75
Steel bars, 2 in. to 4 in. base ..	5 25
Steel bars, 4 in. and larger base ..	6 50
Iron bars, base, Montreal ..	3.50
Steel bars, base, Montreal ..	4 00
Reinforcing bars, base ..	3 75
Bessemer ribs, heavy, at mill ..	3.75
Steel bars, Pittsburgh ..	4 00
Tank plates, Pittsburgh ..	4 00
Bennis and angles, Pittsburgh ..	4 00
Steel hoops, Pittsburgh ..	4 00
F.O.B. Toronto Warehouse.	
Steel bars, base ..	3.75
Small shapes ..	4.00
F.O.B. Chicago Warehouse	
Steel bars ..	3.75
Bars, 2 in. and up ..	4.25
Structural shapes ..	3.85
Plates ..	4.50

FREIGHT RATES.

Pittsburgh to Following Points Per 100 lbs.

	C.L.	L.C.L.
Montreal ..	23.1	31.5
St. John, N.B. ..	35.1	45.5
Halifax ..	35.1	45.5
Toronto ..	18.9	22.1
Quebec ..	18.9	22.1
London ..	18.9	22.1
Windsor ..	18.9	22.1
Winnipeg ..	64.9	85.1

METALS.

Montreal Toronto	
Lake copper ..	\$36 00 \$36 00
Electro copper ..	36 00 36 00
Castings, copper ..	36 00 36 00
Tin ..	47 00 47 00
Spelter ..	13 50 13 50
Lead ..	10 00 9 50
Antimony ..	15 00 18 00
Aluminum ..	70 00 68 00

Prices per 100 lbs.

BOILER PLATES.

Montreal Toronto	
Plates, 1/2 to 1 1/2 ..	\$5 40 \$5 40
Heads ..	5 75 5 75
Tank plates, 3-16 in. ..	5 50 5 50

WROUGHT PIPE.

Baitwell.

Prices in effect Dec. 30, 1916.

Per 100 feet - Black Galv.

1/8 in. ..	\$ 4 25	\$ 5 75
1/4 in. ..	5 54	5 67
3/8 in. ..	5 54	5 67
1/2 in. ..	4 59	6 16
5/8 in. ..	5 64	7 76
1 in. ..	8 33	11 48
1 1/4 in. ..	11 27	15 53
1 1/2 in. ..	13 48	18 56
2 in. ..	18 13	24 98
2 1/2 in. ..	28 47	39 49
3 in. ..	37 49	51 64
3 1/2 in. ..	46 92	63 94
4 in. ..	55 59	75 76

Lapweld.

2 in. ..	21 09	27 57
2 1/2 in. ..	31 59	41 83
3 in. ..	41 31	54 70

3 1/2 in.	51 52	68 54
4 in.	61 04	81 21
1 1/2 in.	71 12	94 62
5 in.	82 88	110 30
6 in.	107 50	143 00
7 in.	142 80	186 80
8 in. L.	150 00	196 30
8 in.	172 80	226 10
9 in.	207 00	270 80
10 in. L.	192 00	253 20
10 in.	247 20	323 40

Prices Ontario, Quebec and Maritime Provinces.

WROUGHT NIPPLES.

4" and under, 60%.

4 1/2" and larger, 50%.

4" and under, running thread, 40%.

Standard couplings, 4" and under, 50%.

4 1/2" and larger, 30%.

OLD MATERIAL.

Dealers' Buying prices.

Montreal Toronto	
Copper, light ..	\$19 00 \$21 75
Copper, crucible ..	24 00 25 25
Copper, heavy ..	23 00 24 50
Copper wire ..	23 00 24 50
No. 1 machine composition ..	20 50 19 50
No. 1 composition turnings ..	16 50 17 00
New Brass clip-pings ..	16 50 17 00
No. 1 brass turnings ..	15 00 15 00
Steel, low phos. ..	14 00 14 00
Heavy Melting steel ..	13 00 14 00
No. 1 machine cast iron ..	20 00 16 00
Steel turnings ..	7 00 7 00
Boiler plate ..	12 00 10 50
Rails ..	14 75 15 00
Axes, wrought iron ..	19 00 24 00
Tires, steel ..	12 00 11 00
Rails ..	13 75 14 00
Shafting ..	20 00 20 00
Malleable scrap ..	10 25 11 00
Pipe, wrought ..	10 50 9 00
Stove plate ..	13 00 13 00
Heavy lead ..	7 50 7 75
Tea lead ..	6 00 5 50
Scrap zinc ..	7 50 7 00
Aluminum ..	35 00 35 00

BOLTS, NUTS AND SCREWS.

Per Cent.

Coach and lag screws ..	35
Stove bolts ..	55
Plate washers ..	20
Machine bolts, 7-16 and over ..	15
Machine bolts, 3/8 and less ..	25
Blank bolts ..	15
Bolt ends ..	15
Machine screws, 1/2 and rd. hd., steel ..	27 1/2
Machine screws, 3/8 and 1/2 hd., steel ..	10
Machine screws, 1/2 and rd. hd., brass ..	add 20
Machine screws, 3/8 and 1/2 hd., brass ..	add 25
Nuts, hex., up to 1 in., \$3.75 per lb. off.	
Nuts, hex., over 1 in. \$2.00 per lb. off.	
Copper rivets and burrs, list plus ..	30
Burrs only list plus ..	50
Iron rivets and burrs ..	27 1/2
Boiler rivets, base 3/4-in. and larger ..	\$5.25
Structural rivets, as above ..	5.15
Wood screws, flat, bright ..	75
Wood screws, O. & R., bright ..	70
Wood screws, flat, brass ..	42 1/2
Wood screws, O. & R., brass ..	40
Wood screws, flat, bronze ..	35
Wood screws, O. & R., bronze ..	32 1/2

MILLED PRODUCTS.

Set screws ..	Per Cent. 49
Sq. & Hex. Head Cap Screws ..	30
Rd. & Fil Head Cap Screws ..	15
Flat & But. Hd. Cap Screws plus ..	15
Pin. & semi-fin. nuts up to 1 in.	30
Pin. and semi-fin. nuts, over 1 in.	25
Studs ..	15
Taper pins ..	45
Coupling bolts, plus ..	15
Planer head bolts, without fillet ..	15
Planer head bolts, with fillet ..	net
Planer head bolt nuts, up to 1 in.	30
Planer head bolt nuts, over 1 in.	25
Planer bolt washers ..	plus 10
Hollow set screws ..	list plus 40
Collar screws ..	list plus 20
Thumb screws ..	20
Thumb nuts ..	70
Patch bolts ..	add 65
Cold pressed nuts to 1 1/2 in.	add 3.50
Cold pressed nuts over 1 1/2 in.	add \$2.00

BILLETS.

Per gross ton	
Bessemer billets ..	\$60 00
Open-hearth billets ..	60 00
O.I.L. sheet bars ..	60 00
Forging billets ..	80 00
Wire rods ..	70 00
F.o.b. Pittsburgh.	

NAILS AND SPIKES.

Wire nails ..	4 75	4 76
Cut nails ..	4 00	4 00
Miscellaneous wire nails ..	65%	
Pressed spikes, 5/8 diam., 100 lbs.	\$4 10	

MISCELLANEOUS.

Solder, guaranteed ..	0 28 1/2
Solder, strictly ..	0 25 1/2
Babbitt metals ..	11 to 60
Soldering coppers, lb.	0 53
Putty, 100-lb. drums ..	3 35
White lead, pure, cwt.	14 25
Red dry lead, 100-lb. kegs, per cwt.	13 87
Glue, French medal, lb.	0 25
Tarred slaters' paper, roll ..	0 95
Gasoline, per gal., bulk ..	0 28 1/2
Benzine, per gal., bulk ..	0 27 1/2
Pure turpentine, single bbls., gal.	0 71
Linseed oil, raw, single, bbls.	1 12
Linseed oil, boiled, single bbls.	1 15
Plaster of Paris, per bbl. ..	2 50
Plumbers' oakum, per cwt. ..	8 00
Packing, square braided ..	0 27
Packing, No. 1 Italian ..	0 32
Packing, No. 2 Italian ..	0 25
Lead wool, per lb.	0 12
Pure Manila rope ..	0 25 1/2
Transmission rope, Manila ..	0 28 1/2
Drilling cables, Manila ..	0 28 1/2

POLISHED DRILL ROD.

Discount off list, Montreal and Toronto ..	25%
--	-----

CARBON DRILLS AND REAMERS.

Per Cent.	
S.S. drills, wire sizes ..	20
S.S. drills, 1 1/16 in. and larger ..	35
Standard drills to 1 1/2 in. ..	35
Standard drills, over 1 1/2 in. ..	10
3-fluted drills to 1 1/2 in. ..	20
3-fluted drills, over 1 1/2 in. ..	10
Bit stock ..	35
Ratchet drills ..	Net
Machine bits for wood ..	15
S.S. drills for wood ..	45
Wood boring brace drills ..	35
Electricians ..	25
Sockets ..	30

Sleeves ..	40
Taper pin and taper reamers "Premier" and "Leader" chucks ..	30
Arbors for above ..	10
Drills and countersinks ..	net
Bridge reamers ..	list plus 30
Centre reamers ..	55
Chucking reamers ..	10
Hand reamers ..	15
High-speed drills up to 1 1/2 in. and over 1 1/2 in. are now double list.	

COLD ROLLED SHAFTING.

At mill ..	list plus 40%
At warehouse ..	list plus 50%

Discounts off new list. Warehouse price at Montreal and Toronto.

IRON PIPE FITTINGS.

Canadian malleable, A, add 10%; B and C, 10%; cast iron, 35%; standard bushings, 50%; headers, 60; flanged unions, 40; malleable bushings, 50; nipples, 55; malleable lipped unions, 50.
--

SHEETS.

Montreal Toronto	
Sheets, Black, No. 28 ..	\$5 00 \$5 75
Sheets, Black, No. 10 ..	5 50 5 60
Canada plates, dull, 52 sheets ..	5 75 5 76
Canada plates, all bright ..	6 50 6 50
Apollo brand, 10% oz. galvanized ..	7 25 7 25
Queen's Head, 28 B. W.G.	7 75 7 75
Fleur-de-Lis, 28 B.W. G.	7 45 7 35
Corbal's Best, No. 28 ..	8 25 7 50
Colborne Crown, No. 28 ..	8 00 6 75
Premier, No. 28 U.S. ..	6 70 7 20
Premier, 10% oz.	7 00 7 50

PROOF COIL CHAIN.

1/4 in.	\$9 45
5-16 in.	9 10
3/8 in.	8 35
7-16 in.	7 15
1/2 in.	6 95
9-16 in.	6 95
5/8 in.	6 80
3/4 in.	6 70
7/8 in.	6 55
1 inch ..	6 40

Above quotations are per cwt.

ELECTRIC WELD COIL CHAIN B.B.

1/4 in.	\$15 50
3-16 in.	11 70
1/2 in.	8 40
5-16 in.	7 40
3/8 in.	6 35
7-16 in.	6 35
1/2 in.	6 35
5/8 in.	6 35
3/4 in.	6 35

Prices per 100 lbs.

FILES AND RASPS.

Per Cent.	
Great Western, American ..	60
Kearney & Foot, Arcade ..	60
J. Barton Smith, Eagle ..	60
McClelland, Globe ..	60
Black Diamond ..	50
Delta Files ..	47 1/2
Nicholson ..	50
Globe ..	57 1/2
Vulcan ..	57 1/2
Disston ..	60

COAL AND COKE.

Solvay Foundry Coke ..	8 50
Connelville Foundry Coke ..	8 50
Yough Steam Lump Coal ..	8 50
Pittsburgh Steam Lump Coal ..	8 50
Best Slack ..	9 00

Net ton f.o.b. Toronto

BOILER TUBES.

Size.	Seamless	Lap-welded
1 in.	\$30 00
1 1/4 in.	30 00
1 1/2 in.	30 00	24 00
1 3/4 in.	29 00	21 00
2 in.	33 00	20 00
2 1/4 in.	33 00
2 1/2 in.	35 75	26 50
3 in.	55 00	31 00
3 1/4 in.	54 50	36 00
3 1/2 in.	59 50	39 00
4 in.	75 00	49 00

Prices per 100 feet, Montreal and Toronto.

OILS AND COMPOUNDS.

Castor oil, per lb.	25
Royalite, per gal., bulk....	12
Machine oil, per gal.	25 1/2
Black oil, per gal.	12 1/2
Cylinder oil, Capital	45 1/2
Cylinder oil, Acme	36 1/2
Standard cutting compound, per lb.	0.6
Lard oil, per gal.	1 45
Union thread cutting oil antiseptic	68
Acme cutting oil, antiseptic	37 1/2
Imperial quenching oil	39 1/2
Petroleum fuel oil	10 3/4

BELTING—NO. 1 OAK TANNED.

Extra heavy, single and double	30-5%
Standard	40%
Cut leather laving, No. 1.	\$1 50
Leather in sides	1 30

TAPES.

Chesterman Metallic, 50 ft.	\$2 00
Luffkin Metallic, 603, 50 ft.	2 00
Admiral Steel Tape, 50 ft.	2 75
Admiral Steel Tape, 100 ft.	4 45
Major Jun. Steel Tape, 50 ft.	3 50
Rival Steel Tape, 50 ft.	2 75
Rival Steel Tape, 100 ft.	4 45
Reliable Jun. Steel Tape, 50 ft.	3 50

WASTE.

White	Cents per lb.
XXX Extra	18
Peerless	18
Grand	17
Superior	17
X L C R	16
Atlas	16
X Empire	15
Ideal	15
X press	14

COLORED.

Lion	12 1/2
Standard	11
No. 1	11
Popular	10
Keen	09

WOOL PACKING.

Arrow	24
Axle	18
Anvil	14
Anchor	11

WASHED WIPERS.

Select White	12
Mixed colored	10
Dark colored	09

This list subject to trade discount for quantity.

RUBBER BELTING.

Standard	50%
Best grades	30%

ANODES.

Nickel50 to .54
Cobalt	1.75 to 2.00
Copper44 to .46
Tin49 to .56
Zinc23 to .25

Prices Per Lb.

COPPER SHEETS.

	Montreal	Toronto
Bars, 1/2 to 2 in.	\$46 00	\$46 00
Plain sheets, 14 oz., 14x28 in., 14x60 in.	45 00	45 00
Copper sheet, tinned, 14x60, 14 oz.	54 00	54 00
Copper sheet, plain, 14x60 base.	57 00	57 00
Braziers' in sheets, 6x4 base	46 50	46 50

BRASS.

Brass rods, base 1/2 in to 1 in rd.	0 55
Brass sheets, 8 in. wide, 20 oz.	0 60
Brass tubing, seamless.	0 55
Copper tubing, seamless.	0 55

PLATING SUPPLIES.

Polishing wheels, felt.	2 10
Polishing wheels, hull-neck	1 35
Emery in kegs, American	06
Pumice, ground	04
Emery glue	15 to 20
Tripoli composition.	04 to 06
Crocus composition.	07 to 08
Emery composition.	08 to 09
Rouge, silver	35 to 50
Rouge, powder	30 to 55

Prices Per Lb.

LEAD SHEETS.

	Montreal	Toronto
Sheets, 3 lbs. sq. ft.	\$12 00	\$12 50
Sheets, 3 1/2 lbs. sq.		

ft.	11 75	12 25
Sheets, 4 to 6 lbs. sq. ft.	11 50	12 00
Cut sheets, 1/2c per lb. extra.		
Cut sheets to size, 1c per lb. extra.		

PLATING CHEMICALS.

Acid, lactic	\$. 15
Acid, hydrochloric05
Acid, hydrofluoric14 1/2
Acid, nitric10
Acid, sulphuric05
Ammonia, aqua08
Ammonium carbonate15
Ammonium chloride11
Ammonium hydrosulphuret40
Ammonium sulphate07
Arsenic, white12
Copper, carbonate, anhy.35
Copper, sulphate17
Cobalt sulphate70
Iron perchloride20
Lead acetate16
Nickel ammonium sulphate12
Nickel carbonate35
Nickel sulphate15
Potassium carbonate75
Potassium sulphate (substitute)20
Silver chloride (per oz.)65
Silver nitrate (per oz.)55
Sodium bisulphite10
Sodium carbonate crystals65
Sodium cyanide, 127-130%41
Sodium hydrate04
Sodium hyposulphite, per 100 lbs.	5.00
Sodium phosphate14
Tin chloride60
Zinc chloride60
Zinc sulphate09

Prices Per Lb. Unless Otherwise Stated.

The General Market Conditions and Tendencies

This section sets forth the views and observations of men qualified to judge the outlook and with whom we are in close touch through provincial correspondents

Montreal, Que., Jan. 15, 1917.—The industrial and commercial world is still much in doubt as to the underlying purposes of recent efforts towards the opening of peace negotiations. This condition of affairs is being reflected in general trade circles, and advance contracts for materials are showing a decrease. Considerable relief in freight congestion is looked for as a result of the reduction in passenger schedules by Canadian railroads.

Pig Iron

Some anxiety has been experienced as a result of recent political events but capacity production is still the order at most furnaces, although difficulty is being experienced in the receipt of raw materials owing to transportation facilities, etc. Some relief has been shown in the coke situation, spot furnace having fallen to \$9 per ton; prompt foundry shows a decline of \$1 per ton the current quotation being \$11 per ton. Canadian pig quotations are practically withdrawn, the nominal price of Victoria being \$40 per ton.

Steel

The steel situation has been little affected by the political happenings referred to. While it is generally con-

ceded that prices have attained a maximum high level, advances here and there still indicate the apparent strength of the market. Owing to existing conditions and the uncertainty of early future developments, consumers are not so keen to place orders for future requirements at the present high prices. The demand for steel plates is very great; in fact it is doubtful if ship building needs will be entirely satisfied for a considerable period after the close of hostilities. It is not improbable that higher quotations may prevail for this class of steel. An advance of \$10 per ton has been placed on tank plates, Pittsburgh, the quotation being now on a basis of \$5 per hundred pounds. Sheet mills are booked many months ahead, but owing to the non-delivery of sheet bars the output has been largely curtailed during the past few weeks. The quotation on blue annealed sheets shows an advance of \$5 per ton, the current price being \$4.75 per hundred. The situation in wire and wire products has continued very firm for some time and it is anticipated that a steady tone will prevail. The demand is very active and mills are operating at full capacity. No local changes have taken place during the week and business is generally brisk.

Metals

Unsettled conditions are still the feature of the metal situation and the general trend is toward weakness. Copper continues to become easier. Tin is uncertain but slightly higher. Spelter is quiet. Trade is steady but showing a slight undertone of weakness. Antimony and aluminum are firm and unchanged.

Copper.—Considerable activity has been shown in this metal during the past week, but the market continues unsettled owing to the uncertain conditions that still prevail. Recent developments, and their bearing on early future possibilities, have somewhat disturbed the confidence of the trade and the situation at present is one of watchful waiting. The steady decline of the past few weeks has resulted from the active selling of resale metal and the feeling that peace negotiations would materially affect the strength of the market. London quotations indicate a weaker market, and New York has also declined on lake and castings, but electrolytic has advanced 3/4c, being now quoted at 29 1/2c per lb. The situation locally continues fairly active and prices are steady and well maintained. Lake and electrolytic are quoted at 36c and castings at 35c per lb.

Tin.—This market continues to hold its firm position but owing to the unreliable nature of the information now obtainable regarding shipments, the situation is anything but settled. The strength of the markets here is largely due to the advancing London market; New York having advanced to 43c, one-

half cent higher than last week. Conditions here are unchanged and prices are firm at 47c per lb.

Spelter.—The situation in spelter shows little change and still carries an air of uncertainty that characterizes conditions generally. However, the buying of spelter is relatively low to that of copper and the trade is rather optimistic regarding the early future. New York is $\frac{3}{8}$ c lower, the current quotation being $9\frac{1}{2}$ c per lb. Dealers here are fairly active and a slight advance is noted; the quotation this week, being 14c per lb.

Lead.—The situation in lead is firm, but an undertone of weakness is developing as a result of prevailing conditions. New York continues to quote $7\frac{1}{2}$ c with a declining tendency. The market here is steady with quotations unchanged at 10c per lb.

Antimony.—Little activity is shown in antimony and the market remains unchanged with prices firm at 15c per lb.

Aluminum.—The market is unchanged and quotations are steady at 70c per lb.

Machine Tools and Supplies

Trade in machine tools is satisfactory, but no pronounced activity is evident. This may be accounted for by the uncertainty that prevails throughout trade and political circles respecting early future conditions. The prospect of additional munitions contracts being placed, when a definite understanding has been reached, may enlarge the requirements of shell makers in respect to additional equipment. An interesting feature that may ultimately result in machine tool activity is the fact of many U.S. firms establishing branches in Canada. While the principal undertaking at present is along munition lines, the possibilities of domestic expansion are very encouraging.

Scrap

Activity in scrap seems to have simmered down to the purchase of actual current requirements and a general depression in prices appears to feature a rather dull situation. New York quotations would seem to indicate a general weakness, but dealers here are optimistic regarding the near future. While the present tendency is for easier prices, those effected this week are confined to scrap brass and zinc. Brass clippings are $\frac{1}{2}$ c lower at $16\frac{1}{2}$; turnings at 15c show a decline of $\frac{1}{4}$ c. Scrap zinc at $7\frac{1}{2}$ is $\frac{1}{2}$ c lower than last week.

Toronto, Ont., Jan. 16.—Industrial activity continues to be largely centered on the production of munitions, the development taking place in this industry being quite remarkable. Coincident with this is a national call for economy in expenditure and increased production arising out of military necessities. The freight situation has not as yet improved, but the new regulations are now in effect, and the congestion in the railway yards will no doubt be relieved to some extent. There is still a shortage of coal and coke,

but some relief is expected shortly, although it is doubtful if the situation will be normal until the spring.

Steel

Renewed activity is developing in the iron and steel trade, and the market appears to have lost little of its previous strength. The upward movement in prices continues, and the situation is tighter than ever before, due to the enormous demand of steel for munitions. On this account it is becoming very difficult to get merchant bars and other steel products, with the result that prices are advancing. A large tonnage of steel will have to be imported from the United States, as the domestic mills cannot meet the extraordinary demand. Prices of iron and steel bars are still withdrawn, and those given in the selected market quotations are, in the meantime, entirely nominal. When new prices are issued they will most probably be around \$4.05 to \$4.10 per 100 lbs. Quotations on such products as plates, tubes and sheets are very firm on account of the situation in the U. S. Higher prices on plates are predicted, due to the continued demand from shipyards and car builders. Plate mills are filled for months ahead, and deliveries consequently are very slow. Prices on locomotive and merchant tubes are largely nominal, as the mills are filled up on both grades for from six to nine months. Prices on wrought pipe are very firm, and a further advance is likely at no distant date. The demand for wire rods is as insistent as ever, and prices are steadily advancing. It is understood that inquiries for 10,000 tons of wire rods have recently been sent to the States by Canadian interests.

The market for black sheets continues very firm, due to the situation in the U. S. The output of sheets is being restricted on account of unsatisfactory deliveries of sheet bars. The output of the mills is largely sold through the first, and partly through the second quarter. Prices of galvanized sheets are also firm, but unchanged.

Pig Iron

The situation in the pig iron market is anything but satisfactory. There has been for some time a considerable falling off in the production of foundry iron owing to the insistent demand for basic pig for steel making. To make matters worse a serious shortage of coke has developed, and some foundries have been obliged to close down temporarily. The coke situation is acute, and there is little prospect of immediate relief. Prices of domestic pig irons are still withdrawn. The Buffalo market is a little more active and prices of foundry irons remain firm at \$35 at furnace.

Scrap

The market for scrap ingot metals is now steadier after the recent decline, but has still a weak tendency. Indications do not point to a revival in the near future, and a further decline in price is not unlikely. Prices of scrap steel, on the other hand, are holding firm, but no

changes have been made during the week. The embargo on the export of steel scrap is tending to depress the market, particularly on steel turnings, as supplies of this material are again accumulating.

Machine Tools

Business has been rather slow during the week compared with the latter part of last year. Prospects, however, are favorable, and a resumption of activity is looked for any time. The building of new munitions plants and extensions to others is bound to have a beneficial effect on the machine tool trade and result in considerable business.

Supplies

Higher prices continue to feature the market for machine shop supplies, due to the high cost of raw materials. The more important lines which have advanced are as follows:—Armstrong tool holders, list plus 40 per cent.; Armstrong ratchets, plus 20 per cent.; Weston ratchets, net list; quick drill vises, plus 20 per cent.; drop forged lathe dogs, plus 15 per cent.; "C" clamps, plus 15 per cent. Drop forged wrenches are 25 per cent. off list. Chucks are unchanged at list, plus 30 per cent., and carbon steel cutters list, plus 40 per cent. An advance has been made on carbon drills, while high speed drills are double list, plus 35 per cent. A new discount of $27\frac{1}{2}$ per cent. has been issued on tinnerns' rivets, as against 30 per cent. formerly. Leather belting is higher, the new discount on extra heavy being 30 and 5 per cent., but standard is unchanged at 40 per cent. Leather lacing is now \$1.50, and leather insides \$1.30. Gasoline and benzine have advanced 1c per gallon, and are now quoted at $28\frac{1}{2}$ c and $27\frac{1}{2}$ c per gallon respectively.

Metals

The situation in the metal markets is practically unchanged, and there have been no developments of importance during the week. The peace proposals are still affecting the market to some extent and will doubtless tend to steady prices for a considerable time. Prices generally are firm and unchanged.

Copper.—The market is steady and prices firm. Practically all the big producers are sold up for six months, and are out of the market. Prices being quoted now are for resale metal. Local quotations are nominal and unchanged at 36c per pound.

Tin.—Quotations in London advanced recently, but the New York market is dull and unsettled, with a small volume of business. Local quotations unchanged at 47c a pound.

Spelter.—The possibility of the war being prolonged has strengthened the spelter market, but prices are unchanged. Local quotation, $13\frac{1}{2}$ c per pound.

Lead.—The market is dull and featureless at unchanged quotations. Local price, $9\frac{1}{2}$ c per pound.

Antimony.—The market continues dull and prices have an easier tendency. Local quotation, 18c per pound.

Aluminum.—The market is quiet and easy, with quotations unchanged at 68c per pound.



No. 4. Inclinable Open Back Press.

Consolidated Presses

represent the highest grade in quality of material, design and workmanship, and have many exclusive features which make for economy in operation, notably the three locking points in the hubs of all flywheels, giving 20 per cent. more production than any press having only two locking points in flywheel to engage clutch.

PRESSES FOR MARKING FUSES, FOR FUSE BODIES, FOR BLANKING, CUPPING AND DRAWING CARTRIDGE CASES.

Also a general line of Punch and Inclinable Presses.

Manufactured by

The Consolidated Press Co.
HASTINGS, MICH.

Get our beautifully illustrated catalog for all the fine points of "consolidated" construction.

Nos. 0, 2½, 3 and 4 carried in stock at Toronto.

The A. R. Williams Machinery Co., Limited
TORONTO, ONTARIO

You Can Depend Upon Geometrics



They are used on every make of Screw Machine—with absolute satisfaction, too.

The majority of Screw Machine users know this. Do you?

Geometric Die Heads are arranged for cutting any diameter, pitch and form of thread. Right or left-hand. Flush to shoulder, where necessary. A micrometer adjustment makes possible quick and accurate variations for a tight or loose-fitting screw. The chasers open automatically, so that no backing-off occurs to injure the thread. Length of thread accurately governed—short or long.

When you are ready, let us aid you. Our publication, **THREADS**, will help us get acquainted. It is free. May we have your address for our mailing list?

THE GEOMETRIC TOOL COMPANY
NEW HAVEN, CONN., U.S.A.

Canadian Agents:— WILLIAMS & WILSON, LTD., MONTREAL. THE A. R. WILLIAMS MACHINERY CO., LTD., TORONTO, WINNIPEG AND ST. JOHN, N.B.

If any advertisement interests you, tear it out now and place with letters to be answered.

INDUSTRIAL ^{AND} CONSTRUCTION NEWS

Establishment or Enlargement of Factories, Mills, Power Plants, Etc.; Construction of Railways, Bridges, Etc.; Municipal Undertakings; Mining News

ENGINEERING

Ottawa, Ont.—The Ottawa Car Co. is building a plant at a cost of \$40,000.

Wingham, Ont.—The Western Foundry Co. contemplate an addition to their foundry here.

Hepworth, Ont.—The Hepworth Light & Power Co. propose building a power plant near here.

Toronto, Ont.—The Consolidated Steel Co. will build an addition to their plant at 1154 Dundas street.

Montreal, Que.—The Canada Stove & Foundry Co. contemplate building an extension to their plant at St. Laurent, near here.

Vancouver, B.C.—The Pacific Great Eastern Railway Co. will commence work soon on a machine shop at Squamish, B.C., to cost \$15,000.

Toronto, Ont.—The Chapman Double Ball Bearing Co., of Canada, have been granted a permit to erect a \$25,000 two-storey brick addition to their factory on Soraraen avenue.

Toronto, Ont.—The Turnbull Elevator Co., John street, have purchased a factory site at the corner of Bloor and Lansdowne, consisting of about 4¼ acres. The price paid for the property is \$106,000.

Orillia, Ont.—A new company known as Electro-Foundries, Ltd., has been formed to take over the smelter and install an electric furnace. Capitalists connected with the International Molybdenum Co. are interested in the new venture.

Montreal, Que.—The Howard Smith Paper Mills Co. will shortly take over the recently purchased Crabtree mill. Plans are being completed for the necessary alterations which will change it from a newsprint to a bond paper mill. The mill will be considerably enlarged, one of the additions consisting of a heater room 125 ft. by 60 ft.

London, Ont.—Beatty Bros., of Ferguson, will establish a foundry at Chelsea Green, along the London & Port Stanley Railway tracks. The building to be erected will cost \$28,000 or \$30,000. The company will manufacture iron pumps, barrel churns, grain grinders and hand and power washing machines. Beatty Bros. have hitherto bought their castings.

Kingston, Ont.—The Kingston Smelting Co., will shortly be running to capacity. The lead that will be smelted in this plant is to be obtained from British Columbia, the United States, and also from mines in this district. At the present time there is an embargo on crude

lead from the United States, but the management hopes to have this removed.

Steel Plant for Toronto.—The Toronto Harbor Commissioners have completed arrangements with the Imperial Munitions Board, through the chairman, J. W. Flavell and Col. Carnegie, whereby the Munitions Board will have erected for them an electric steel and forging plant with an initial capacity of 300 tons per day. Ten six-ton, three-phase 25-cycle Heroult type electric furnaces will be installed.

MUNICIPAL

Cayuga, Ont.—The Town Council propose purchasing gas engines and pumps for a waterworks system.

Brantford, Ont.—The City Council are considering the question of developing hydro power on the Grand River.

Oakville, Ont.—Voting on the by-law to grant certain minor concessions to the Acme Tire & Rubber Co. will take place on Monday, January 22. The company propose establishing a factory here for making rubber tires, etc.

Toronto.—The York Township Council has passed a by-law granting a fixed

CANADIAN GOVERNMENT PURCHASING COMMISSION

The following gentlemen constitute the Commission appointed to make all purchases under the Dominion \$100,000,000 war appropriation:—George F. Galt, Winnipeg; Hormidas Laporte, Montreal; A. E. Kemp, Toronto. Thomas Hilliard is secretary, and the Commission headquarters are at Ottawa.

assessment for the next twenty years to the Canada Cycle & Motor Car Co., with allied businesses under such names as the Russell Motor Car Co., or the Canada Cycle & Motor Car Co. The company are building a factory at Weston.

Toronto, Ont.—A new activated sludge unit is to be given a trial at the Morley Avenue sewage disposal plant. Should it prove successful in preventing odor from spreading. Works Commissioner Harris will recommend that the activated sludge system be adopted for the entire plant. An appropriation for the trial unit will be placed in the estimates of the Works Department.

TENDERS

St. Lambert, Que.—Tenders will be received up to January 22, for the sup-

ply of a horizontal shaft centrifugal pump, electric motor and switchboard. Specifications may be obtained from H. A. Gibean, town engineer, Town Hall, St. Lambert, Chambly Co., P.Q.

Winnipeg, Man.—Tenders will be called until February 12, 1917, for works required for the completion of the new Parliament Buildings, which include the following: Heating and ventilating, electric conduit and wiring. Thos. H. Johnson, Minister of Public Works, Winnipeg.

London, Ont.—Tenders will be received up to Monday, Jan. 29, 1917, for the supply and delivery of: (a) Special railroad track work consisting of five (5) whole and two half crossings of manganese steel construction; (b) Two horse-drawn road oil distributors. Specifications, form of tender, etc., can be seen at the office of H. A. Brazier, city engineer.

Winnipeg, Man.—Tenders addressed to the undersigned will be received up to Monday, February 5, 1917, for the supply of indicating and recording apparatus for two Venturi meters. Specifications and form of tender may be obtained and form of contract may be inspected at the offices of the district. R. D. Waugh, Chairman of Commissioners, 501 Tribune Building, Winnipeg, Man.

GENERAL

Toronto, Ont.—The D. Harris & Co. glue factory may be removed to Ashbridge's Bay. Officials after visiting reduction plants in the United States, found that such a plant by means of proper water cooling devices can be operated without giving forth obnoxious odors.

MARINE

Victoria, B.C.—The auxiliary schooner Margaret Haney, which is being built by the Cameron Genoa Mills Shipbuilders, Ltd., will be launched about the end of January. The 160 h.p. Bollinder engines will be installed after the vessel has been launched.

Yacht "Florence" Sold.—The steam yacht Florence, formerly owned by Sir John Eaton, of Toronto, and since the war began in the service of the Canadian Government as a patrol and scout vessel, has been sold to the French Trading Co., of Martinique, F.W.I. It is understood she will be used by her present owners for commercial purposes. She has left for Fort de France, Martinique.

Shipbuilding Bounties.—From a note in a recent issue of the *Board of Trade*

Journal, we gather that a new Shipbuilding Act for Newfoundland provides for payments to be made to shipbuilding concerns situated in the colony. These payments take the form of making up the net annual profits of 7 per cent. for a term of 15 years should they be below this figure. The Act also provides for free importation of materials for the equipment of shipyards as well as of those used in shipbuilding. Furthermore, the tonnage bounties under the Act of 1908 are to be doubled.

PERSONAL

W. S. Atwood, chief engineer of the Canadian Car & Foundry Co., Montreal, has been appointed operating manager.

Lieut.-Col. L. T. Martin, of O'Brien & Martin, railway contractors, Montreal, has been requested to raise a construction battalion for service in France.

A. G. Pounsford, until recently safety engineer of the Pulp and Paper Manufacturers' Safety Association, has been appointed general manager of the Port Arthur Pulp & Paper Co., with head office in Toronto.

Capt. K. T. P. Woods, who spent many years at sea in the Monarch Line, out of Glasgow, Scotland, and for the past three years has been an officer on the cable ship, *Restorer*, has been appointed shore captain at Vancouver, B.C., for the Pacific Steamship Co.

E. P. Mathewson, of Montreal, was awarded the coveted gold medal of the Metallurgical Society of America for his achievements in metallurgy during the past year, when the annual meeting of America's leading mining organization convened in Montreal recently. The medal is awarded annually to the member performing the most valuable service in the interest of the development of American mineral resources.

BUILDINGS

Toronto, Ont.—The Campbell Flour Mills have been granted a permit to erect a bridge between their mill and warehouse at Monarch road, to cost \$850.

Hamilton, Ont.—The Canadian Westinghouse Co. propose erecting an office building.

RAILWAYS AND BRIDGES

St. John, N.B.—It is reported that the Dominion Government has acquired the International Railway, which runs from Campbellton, N.B., to St. Leonards and the Maine border. It hints at the purchase price being between two and three million dollars.

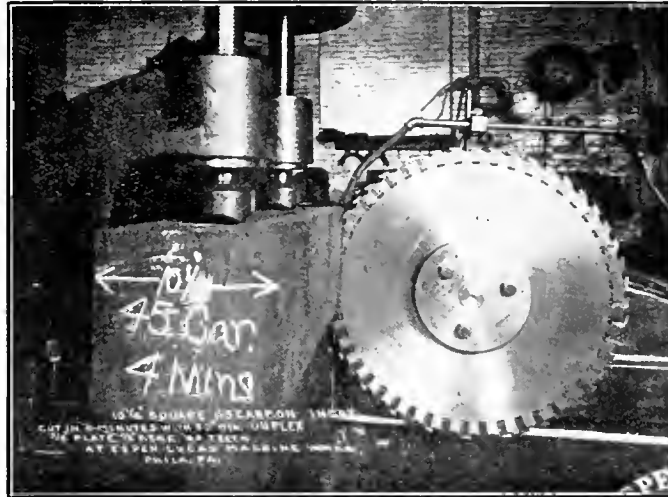

Circular Metal Cutting Saw Blades for Any Type of Machine

Let us demonstrate what a saving can be made by installing a **HUNTER "DUPLEX" Inserted Tooth Blade**

Write for information
HUNTER SAW & MACHINE CO., Pittsburgh, Pa., U.S.A.

If what you want isn't advertised in this issue, consult our Buyers' Directory, page 81.

MORTON MANUFACTURING CO.
PORTABLE PLANERS
DRAW CUT SHAPERS
SPECIAL DRAW CUT R R SHAPERS
FINISHED MACHINE KEYS
STATIONARY & PORTABLE KEY WAY CUTTERS
SPECIAL LOCOMOTIVE CYLINDER PLANERS
OFFICE AND WORKS: MUSKEGON HEIGHTS U.S.A.

THE IRON WORKS LIMITED
Successors to
Owen Sound Iron Works
Owen Sound Ont.
Engineers
Boiler-makers
Founders
Machinists

Tank Work
Smoke Stacks,
Grey Iron and
Brass Castings,
Special Machinery
Made to Order

"Barnes-Made" SPRINGS

are unusual in service and wear

They are the result of sixty years' experience, unsurpassed equipment and highly skilled workmanship.

A trial will convince you that "Barnes-Made" Springs are the best buy.

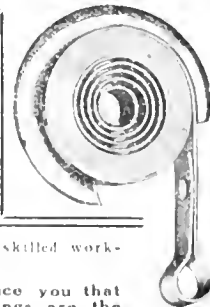

Established 1857
THE WALLACE BARNES COMPANY
218 South St., Bristol, Ct., U.S.A.
Mfrs of "Barnes-made" Products
Springs, Screw Machine Products, Cold Rolled Steel and Wire

METAL STAMPINGS

We are manufacturers of stamped parts for other manufacturers.

We do any kind of sheet metal stamping that you require. Our improved presses and plating plant enable us to produce the finest quality of work in a surprisingly short time.

We can finish steel stamping in Nickel, Brass or Copper.

Send us a sample order.

W. H. BANFIELD & SONS
372 Papo Avenue, Toronto, Can.

I BELIEVE

In Safety First and always.
In Providing for the Health of my Fellow
Workmen.
In Light and Air and sanitary Working Con-
ditions.
In clean, fresh drinking water for everybody.
In the Safety, Economy and Man-betterment.

PURO SANITARY DRINKING FOUNTAIN

(MADE IN CANADA)

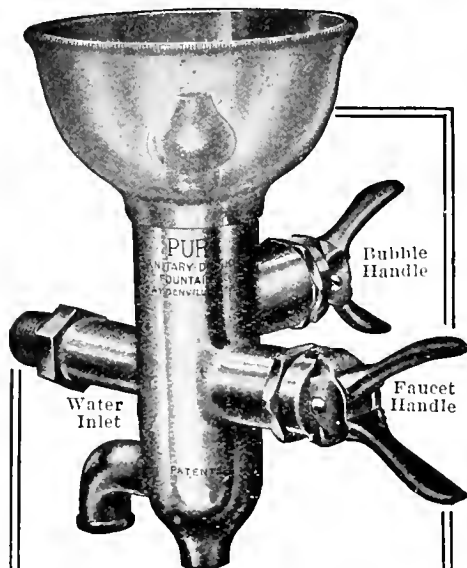

The loss of a man through impure drinking water is a crime that "the front office" must bear.

An ugly statement, isn't it? But true, absolutely.

When a man comes to work in your factory he puts his health in your keeping.

Are you willing to take chances on such a trust?

Impure drinking conditions are responsible for more tragedies than any machine ever built.

Apply the "Safety First" Principles to your water supply; don't deny your men a clean, fresh drink of water.

Conserve their health and they will improve your profits; make yourself as worthy of the name of "employer."

Install the Gold Medal winner Puro in your plant, office and shop alike.

The only Sanitary Drinking Fountain that is safe, sanitary, simple, automatic in control and easily attached.

Let us tell you just what it will cost you to

WOODWORKING

North Vancouver, B.C.—Fire recently damaged the North Vancouver Sash & Door Co.'s factory to the extent of \$3,500, which is partly covered by insurance.

TRADE GOSSIP

A. C. Leslie & Co., Montreal announce the completion of 50 years in business. Present officers of the company are as follows: President, William S. Leslie; vice-president, Thomas H. Jordan; director and secretary Edward H. Copland.

The Canadian SKF Co. has opened an office at 47 King Street West, Toronto, where a complete stock of ball bearings will be carried. The Canadian Fairbanks Morse Co., will continue as sales agents for transmission equipment made by the parent concern at Hartford, Conn.

The Albany Pump Co. has equipped a plant at 16 Pearl street, Toronto, for making the "Albany" rotary pump and munitions gauges. A. W. Bennet, who is proprietor and manager of the concern, formerly carried on business at 206 King street west, Toronto, as Canadian agent for the "Albany" pump.

The Clark Equipment Co., Buchanan, Mich., has taken over the business of the Celfor Tool Co. and the Buchanan Electric Steel Co. The new company has been organized for the above purpose and the merger is solely for the purpose of strengthening both concerns. There will be no change in either the manufacturing or selling methods of either company.

The Imperial Oil Co., held its annual convention at Sarnia, Ont., from Jan. 9 to Jan. 13 which was attended by about 65 managers and salesmen of the Ontario Division. The convention was presided over by G. W. Mayer, managing director of the company. A number of interesting papers were read and a banquet lent additional interest to the proceedings.

Lake Lines to Raise Rates.—The International Water Lines Passenger Association, at its convention held at Quebec recently, decided to raise the passenger traffic rates on the Great Lakes, and certain rivers in the United States, as well as in Canada, but the Canada Steamship Lines, Ltd., announce they will not raise their rates on the St. Lawrence to the Saguenay River.

The George T. Ladd Co., Pittsburgh, Pa., announce that the name of what was originally the "Milne" boiler has been changed to the "Ladd" water tube boiler. The change has been made on account of improvement in design affecting the settings, feed boxes and other details to the extent that the majority of the patents which the company are

utilizing have been taken out by George T. Ladd, president of the company.

Hyde & Sons Ltd., Montreal have recently added a new department to their business to include foundry supplies and equipment. The company at a late date contemplate taking up the manufacture of certain lines that are at present being imported into Canada. Frank M. Meyers, who has had extensive experience in foundry practice-construction and production will be in charge of the new department.

The Sterling Engine Works have taken over the plant and business of the Doty Engine Works, Winnipeg, with works and office at the foot of Water Street. While it is their intention to manufacture farm tractors as a specialty, they will also make boilers, steam and gasoline engines, iron and brass castings, cut gears, for which their plant is specially equipped, as well as general repair work. The president of the new company is V. C. Maddock, the secretary-treasurer F. Nilan, and W. J. Leaney is manager.

Cochrane, Ont.—Located on the Mattagami River, thirty-one miles west of here, is the site of the plant of the new Mattagami Pulp & Paper Co. This concern's operations, involving expenditures on construction amounting to \$2,500,000, bring an important new industry to New Ontario. Just now the construction of pulp mills and hydraulic plant is being actively carried on with a view to having them in operation by next June. The company's Board of Directors are: Duncan Chisholm, Toronto, president; E. P. Shove, Colorado Springs, Colorado, vice-president; W. D. Ross, Toronto; N. B. MacKelvie, New York, and Lieut.-Col. D. M. Robertson, Toronto, secretary and treasurer.

Will Assist Refineries.—It is announced in Ottawa that the business of refining lead, copper and zinc is to be encouraged by the Canadian Government. Finance Minister White intimates that at the approaching session of the Dominion Parliament a Government bill will be presented providing aid by bounty or tariff for the refining of these metals. This is another step in the process of transferring from the United States to Canada the entire North American business of munition making. Canada has great supplies of the metals required for shells but up to the present most of the refining of Canadian matte—lead, copper, zinc and nickel—has been done in the United States. The Canadian munition business is growing to such a volume that the Government has decided that the whole process of producing proper metals for shells shall be carried on in Canada.

INCORPORATIONS

Samuel Osborn (Canada) Ltd., have been incorporated at Ottawa with a capital of \$50,000 to manufacture and

"PURO - FY"

YOUR WATER SUPPLY

Puro Sanitary Drinking Fountain Company
147 University Ave., Toronto, Canada

HAVE YOU

read pages 56 to 61?
Turn to them now
and see for yourself
whether or not they
are of interest.

Canadian Machinery
Classified Advertising Section

deal in steel and other metals at Montreal. Incorporators are A. E. Myles, F. J. Laverty and J. W. Blair all of Montreal.

Robert Maw & Co., have been incorporated at Ottawa with a capital of \$50,000 to manufacture iron and wood-working machinery etc. Head office is at Montreal and the incorporators are T. B. Gould, C. Thomas and L. M. Smith all of Montreal.

Water Purification Ltd., has been incorporated at Ottawa with a capital of \$40,000 to manufacture and deal in water purification and filtration plants at Ottawa, Ont. The incorporators are E. M. Knight, J. T. Mitchell and W. A. Wyman all of Ottawa.

Ajax Rubber Co. of Canada, Ltd., has been incorporated at Ottawa with a capital of \$1,000,000 to manufacture rubber goods of all kinds. The head office is at Toronto and the incorporators are W. D. Hamilton, R. S. Gilpin and Y. F. Selby all of Toronto.

Industrial Chemicals Ltd., have been incorporated at Ottawa with a capital of \$2,750,000 to manufacture chemicals, chemical compounds, dyes and dyestuffs etc., at Montreal. The incorporators are G. W. McDougall, L. Macfarlane, and W. B. Scott all of Montreal.

The Stevens-Aylsworth Co., have been incorporated at Ottawa with a capital of \$10,000 to manufacture mechanical and electrical apparatus and machinery. The head office is at Toronto and the incorporators are W. Gilchrist, R. D. M. Moore and J. Stewart all of Toronto.

Lake Winnipeg Paper Co., has been incorporated at Ottawa with a capital of \$5,000,000, to manufacture pulp and paper. Head office is at Ottawa and the incorporators are Duncan B. McDonell, of Winnipeg, also Edward Seybold and Angus W. Fraser of Ottawa.

The Universal Machinery Co., have been incorporated at Ottawa with capital of \$200,000 to carry on the business of manufacturers of iron and wood-working machinery, steel makers, iron and brass founders etc. at Montreal. The incorporators are H. Johnson, C. R. Jones and F. T. Malone.

The Collingwood Shipbuilding Co., has been incorporated at Ottawa with a capital of \$2,600,000 to take over the plant and business of the Collingwood Shipbuilding Co., at Collingwood, Ont. The incorporators are R. H. Parmenter, Arthur J. Thomson and Samuel Davidson all of Toronto.

ELECTRICAL

Alton, Ont.—The Hydro-Electric by-law was carried here on Monday.



Steel Shell Forgings or Billets of any size or weight will move any distance or about curves upon our specially constructed Gravity Carriers and Incline or Horizontal power devices. No labor required.

Canadian Mathews Gravity Carrier Co., Toronto, Ont.

We are qualified Tool, Die, Jig, Gauge and Fixture Makers.

WRITE US.

Windsor Machine & Tool Works.
WINDSOR, ONT.



OVENS

Enameling and Varnishing.
OVENS Heated by
GAS, ELECTRICITY, STEAM or COAL
Write for New Pamphlet Just Issued
Branford Oven & Rack Co., Ltd., Branford, Canada

STEEL CASTINGS

We are in a position to make immediate delivery of all kinds of steel castings, 100 lbs. and heavier.

Send us your next order.

Dominion Steel Foundry Co., Ltd.

Hamilton, Ont.

PATENT ATTORNEYS

BABCOCK & SONS

ESTAB. 1877
PATENTS-TRADE MARK-DESIGNS
IN ALL COUNTRIES

Book "Patent Protection"—free. Master of Patent Laws. Formerly Patent Office Examiner.

99 St. James St., Montreal, Que.
Branches: Ottawa, Washington.

RESEARCH BUREAU

REPORTS BY EXPERTS ON SCIENTIFIC, TECHNICAL AND INDUSTRIAL DEVELOPMENT.

SPECIAL RESEARCHES ARRANGED.

PATENTS, TRADE MARKS, ETC.

HANBURY A. BUDDEN CABLE ADDRESS
712 DRUMMOND BLDG., MONTREAL "BREVET"

PATENTS TRADEMARKS AND DESIGNS
PROCURED IN ALL COUNTRIES

Special Attention given to Patent Litigation

Pamphlet sent free on application.

RIDOUT & MAYBEE 59 Yonge Street
TORONTO, CANADA

PATENTS

Fetherstonhaugh & Co.
Patent Solicitors. Head Office,
Royal Bank Bldg., Toronto.
Ottawa Office, 5 Elgin St.
Send for our Plain Practical
Pointers. Copy of National
Progress, in which our patents
are advertised, mailed free.

MacKinnon, Holmes & Company, Limited

Design, manufacture and erect all classes of Steel Work.

Specialties:-

- Bridges
- Oil and Water Tanks
- Penstocks
- Coal and Coke Bins
- Smoke Flues & Stacks.

Prompt deliveries assured.

Designs and Estimates from Head Office at

SHERBROOKE, QUE.

CATALOGUES

The Vanadium-Alloys Steel Co., Pittsburgh, Pa., has for free distribution a folder descriptive of Vaseo-Marvel, a semi-high-speed steel. This folder contains much information of interest, together with the high-speed steel standard classification of extras adopted July 22, 1915.

Hammers.—The United Hammer Co., Boston, Mass., have issued a bulletin describing and illustrating the "Fairbanks" hammer. The principal features are dealt with in detail, while each type is illustrated and accompanied by a table giving the capacity and principal dimensions of each size.

Kasemit, Ltd., London, England, have issued a catalogue dealing with the "Kasemit" compounds for all purposes or carbonizing, surface and tool hardening. The claims made for these compounds, the chief of these being tabulated control and accuracy of results, are dealt with at length.

Boiler Feed Pumps.—The G. H. Tod Co., Ltd., have issued a bulletin illustrating and describing the Tod-Attwood patent vertical ram boiler feed pumps. The principal features of this pump are dealt with in detail while a table is included giving the principal dimensions and other particulars for each size.

"Libby" Lathes in Automobile Shops, is the title of a catalogue issued by the International Machine Tool Co., Indianapolis, Ind., featuring the large number of automobile parts that can be machined on the "Libby" turret lathe. The principal matter contained in this catalogue consists of dimensioned diagrams of these parts machined in this lathe and the time taken in performing each operation.

BOOK REVIEW

The North Eastern Railway have issued from the Commercial Agents' Office at York, England, a Directory of manufacturers, wholesale importers and exporters situated on the North Eastern Railway System. The directory contains 1,300 pages arranged in two sections, "Towns under Trades," and "Trades under Towns," the latter section being the reverse of the former. This is a useful publication for Canadian firms desiring to open up business connections with concerns in the North Eastern district.

Steam Boilers and Combustion, by John Batey. 220 pages, 4 3/8 in. x 7 1/4 in., with 18 diagrams. Published by Scott, Greenwood & Son, London, England. Price \$1.25, post free. This volume is the fifteenth of the Broadway Series of Engineering Handbooks. In this book the author has striven to deal with the subject in a somewhat different manner than that usually found in works on this subject. Problems of combustion are examined and as far as possible cause is traced back from effect, the causes be-

ing referred to well known facts as a comparison. Although the application of certain principles is sometimes questioned, they are accepted as a whole. All analysis is based on recognized science and results compared with authorized deductions. The book contains an introduction and seventeen chapters, dealing successively with various subjects, such as combustion and steam production, principal constructional features of various types of steam boiler, steam boiler practice, temperature, etc. This briefly covers chapters one to twelve, inclusive. The principal subjects dealt with in the concluding chapters include lessons taught by experiment, Philadelphia exhibition lists, normal results obtained by abnormal methods, analysis of actual performance of a locomotive boiler and lastly, movement of gases through tubes. The book, while being in a measure technical, is clear and concise, and contains much valuable information on a phase of boiler operation which is frequently not given the attention that its importance merits. In addition to the diagrams, the book contains a number of tables and some useful rules and examples.

Heaton's Annual, Heaton's Agency, Toronto, price \$1 net. The thirteenth edition of Heaton's Annual has just come from the press, and again we have to note improvements and refinements which have marked its progress from year to year. Heaton's Annual endures because recognized as a necessity both in the office and the home. Indeed, to financial or commercial houses in Canada or abroad and who do business with Canada, the book is indispensable, the expression, "Look it up in Heaton's," having become a habit in many households. The first part of the book contains complete official directories of the Dominion and Provincial Governments, to which is added this year a long list of titled and decorated Canadians that will be of interest to many families who have boys at the front; also postal information; a shipper's guide, giving every banking town, with banks and railway connections, population, etc.; commercial regulations and complete customs tariff revised to date. In the last half of the book we find up-to-date complete descriptions of every commercial town in Canada with hotels, industries, population and industrial opportunities, and an invaluable and complete summary of the resources of the Dominion, covering agriculture, agricultural districts, finance, fisheries, forests, fur farming, mining, sport, water powers, etc. The information is full, live, clearly arranged and concisely stated. Cross references are given throughout the text to a most valuable bibliography of Government and standard publications under the heading, "Where to Find It," so that the reader has access to complete information upon any subject in which he is interested. The handsome illustrated advertisements of the Provincial Governments and Boards of Trade are proof that the work receives official appreciation.

CANADIAN MACHINERY AND MANUFACTURING NEWS

A weekly newspaper devoted to the machinery and manufacturing interests.

Vol. XVII.

TORONTO, JANUARY 25, 1917

No. 4

EDITORIAL CONTENTS

Safe Practice at Blast Furnaces and Its Development	55-60
General	60
Commercial Accuracy in Standardized Parts....Empire Mineral Resources....Census of Manufactures....Foundrymen's Convention and Exhibition.	
Editorial Correspondence	61-62
Preliminaries in Machine Part Production Methods—11 Home-made Check Valve for Boiler Test Pumps....Simple Arrangement for Straining Work Ladder Chain and Its Manufacture.	
Spokes in Industry's Wheel	63-64
Fred W. Evans.	
General	64-65
Screw Cutting in Aluminum....Canadian Pulp and Paper....Silvering Brass for Lac- quering....Steel Plant Extensions in 1916....Twin Mill Furnace for Hardening High Speed Steel....Controlled Establishments and Secrecy.	
Progress in New Equipment	66-68
Duplex Shell Lathe....Sensitive Multiple Spindle Drilling Machine....Scrap Reclaim- ing Press....Extra Heavy Duty 26 in. Engine Lathe....Screw Machine Equipment.	
Editorial	69
An Eventful Week....His Majesty's Canadian Torpedo Boat "Grilse" Balking "Safety First."	
Selected Market Quotations	70-71
The General Market Conditions and Tendencies	71-71
Montreal Letter....Toronto Letter.	
Correspondence	71
H.M.C. Torpedo Boat "Grilse."	
Industrial and Construction News (Advertising Section)	56

THE MACLEAN PUBLISHING COMPANY, LIMITED

JOHN BAYNE MACLEAN, Pres. H. T. HUNTER, Vice-pres. H. V. TYRRELL, Gen. Man.

Publishers of Hardware and Metal, The Financial Post, MacLean's Magazine, Farmer's Magazine, Canadian Grocer, Dry Goods Review, Men's Wear Review, Printer and Publisher, Bookseller and Stationer, Canadian Machinery and Manufacturing News, The Power House, The Sanitary Engineer, Canadian Foundryman, Marine Engineering of Canada.

Cable Address: Macpubco, Toronto; Atabek, London, Eng.

ESTABLISHED 1887.

CANADIAN MACHINERY AND MANUFACTURING NEWS

PETER BAIN, M.E., Editor. R. G. NEWTON, Manager.

Associate Editors: A. G. WEBSTER, J. M. WILSON, J. H. ROUGHERS.

CHIEF OFFICES:

CANADA—Montreal, 701-702 Eastern Townships Building; Toronto, 413-415 University Ave., Telephone Main 7341; Windsor, 22 Royal Bank Building, Telephone Garry 2313.

GREAT BRITAIN—LONDON, The MacLean Company of Great Britain, Limited, 88 Fleet Street, E.C. 4; J. H. Bodd, Director, Telephone Central 1260. Cable Address: Atabek, London, England.

UNITED STATES—New York, R. B. Huestis, 115 Broadway, N.Y., Telephone Redford 8971; Boston, C. E. Merton, Room 733, Old South Building, Telephone Main 1201; A. H. Byrne, 11015-67 Fort Dearborn Bldg., 105 W. Monroe St., Chicago, Telephone Randolph 3234.

SUBSCRIPTION PRICE—Canada, Great Britain, South Africa and the West Indies, \$3.00 a year; United States, \$3.50 a year; other countries, \$4.00 a year; Single Copies, 15 cents. Invariably in advance.

Hendey Millers will take any kind of a miller job

that comes into the modern shop

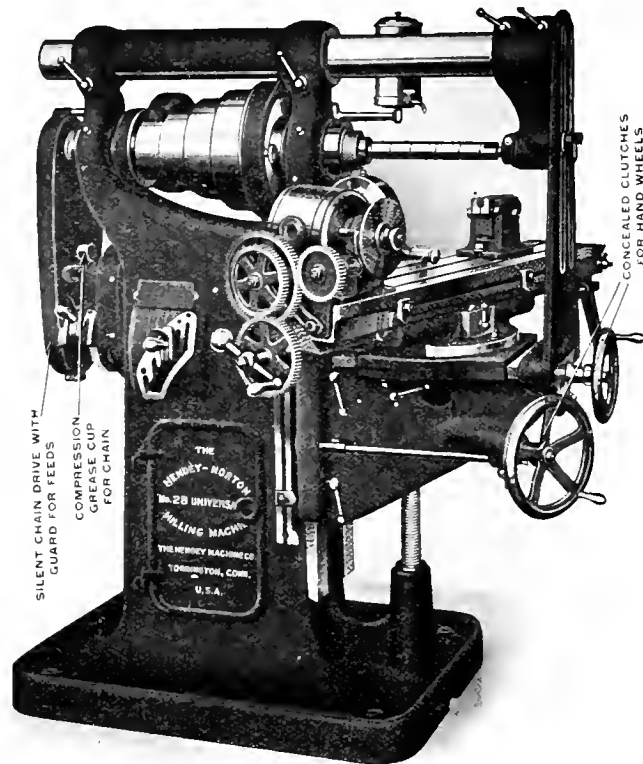

and it delivers the finished work in the highest degree of accuracy and perfection. It has a wide range of spindle speeds (16) and feeds (18).

The "Hendey" is free from the usual complicated features. All working positions are secured with but few and easily understood movements on the part of the operator. Anyone can operate the "Hendey Miller." No special skill is required to get the service that the Hendey's built for.

Write for the "Hendey Miller" Book. It is certain to interest you.

The Hendey Machine Co.
Torrington, Conn., U.S.A.

Canadian Agents: A. R. Williams Machinery Co., Toronto, Ont.; A. R. Williams Machinery Co., 260 Princess St., Winnipeg; A. R. Williams Machinery Co., Vancouver; A. R. Williams Machinery Co., St. John, N.B.; Williams & Wilson, Montreal.

INDEX TO ADVERTISERS

Aeroplane Products, Ltd.	103	Cummings, J. M., & Sons 115	Jacobs Mfg. Co.	100	Pres-O-Lite 115	
Aikenhead Hdw. Co.	57	Cushman Chuck Co.	Jarline Co., A. B.	86	Pringle, R. E. T., Ltd. 33	
Allen, John F., Co.	75	Darling Bros., Ltd.	Jencks Mach. Co.	9	Pritchard-Andrews Co., of Ottawa. 28	
American Pulley Co.	78	Davenport Loco. Works 21	Johnson Mach. Co., Carlyle 76	9	Puro Sanitary Drink'g Fountain Co. 58	
Armstrong Bros. Tool Co.	105	Davis, W. F., Machine Tool Co. 71	Joyce Geo. A. Co.	100	Racine Tool & Machine Co. 23	
Armstrong, Whitworth of Canada. 7		Deloro Smelting & Refining Co. 8	Kemp Smith Mfg. Co.	95	Reliance Mach. Co.	75
Atkins, Wm., & Co., Ltd.	11	Delta File Works 56	Kennedy, Wm. & Sons 12		Riverside Machy. Depot 69	
Atlas Crucible Steel Co.	17	DeMory Mach. Co.	Ker & Goodwin 63		Rockford Drilling Machine Co. 111	
Aurora Tool Works 86		Dennis Wire & Iron Works 29	Keystone Mfg. Co.	113	Roelofson Machine & Tool Co. 13	
Babcock & Sons 59		Dept. of Finance 117	L'Air Liquid Society 117		Roper & Co., C. F.	73
Baird Machine Co.	150	Dickow, Fred, C.	Landis Machine Co.	118	Scott Machy. Co., G. H.	26
Baird Macay, Co., W. J.	68	Dodge Mfg. Co.	London Bolt & Hinge Co. 63		Scott, F. H.	153
Banfield, E. J.	12	Dominion Belting Co., Ltd. 62	Lymburner, Ltd.	23	Sheldons, Ltd.	26
Banfield, W. H., & Sons 61		Dominion Bridge Co.	80	Shore Instrument Co.	101	
Barnes, W. F., & John.	84	Dominion Forge & Stamping Co. 74	Macnab, John, Machy. Co.	—	Shuster Co., F. B.	130
Barnes, Wallace, Co.	61	Dominion Iron & Wrecking Co. 82	Magnolia Metal Co.	80	Simmons Mach. Co., Inc. 70 and 92	
Bemis & Call Hardware & Tool Co. 104		Dominion Machinery Co. 38	Main Belting Co.	59	Skinner Chuck Co.	102
Bertram, John, & Sons Co., Ltd.	104	Dominion Steel Foundry Co. 61	Marion & Marion 59		Slocum, Avram & Slocum 84	
Front cover and page 1		Eastern Mach. Screw Corp. 91	Manufacturers Equipment Co. 73		Smooth-On Mfg. Co.	93
Betham's, Limited 63		Elmes, Chas. F.	Marsh & Henthorn, Ltd. 88		Spartel Co., L. S.	21
Blake-Warrens Co.	85 and 87	Eric Foundry Co.	Matthews, Jas. H., & Co., Inc. 100		St. Clair Bros. & Co.	60
Blake Pump & Condenser Co. 91		Etherstonhaugh & Co. 59	McCabe, J. J.	98	Stede, Ltd., James 60	
Bless, E. W., Co.	74	Fitzgerald, W. H. J.	Mc'Goy-Brandt Machy Co. 68		Steel Co., of Canada 3	
Bowser, S. F.	71	Fleck, Alexander, Limited 63	McDougal Co., H. Inside back cover		Steppe, John, Co.	96
Bramford Oven & Rack Co. 49		Ford Chain Block & Mfg. Co. 78	McKay, James Co.	14	Stirk & Sons, John 63	
Bridgford Mach. Tool Works 5		Ford-Smith Mach. Co.	McKenzie, The D. K. Machy. Co. 29		Stocker, H. A. Machy. Co. 71	
Bristol Company 96		Foss & Hill Machy. Co.	McLaren, J. C., Belting Co. 101		Stow Mfg. Co.	93
Brown, Bogs 14		Foundry & Mach. Co.	Mechanical Engineering Co. 111		Strong & Heys Co.	68
Brown Engineering Corp. 84		Galt Mach. Screw Co.	Metalwood Mfg. Co.	24	Swedish Gage Co., Inc.	83
Brown & Sharpe 107		Gardner Machine Co.	Millholand Co., W. K.	16	Sturtevant Co., B. F.	9
Brownell Machy. Co.	68	Gardner, Robt., & Sons 102	Moody & Hawley 132		Swedish Steel & Importing Co. 9	
Brown's Copper & Brass Rolling Mills 31		Garlock-Walker Machy. Co. 84	Montgomery Smith & Co. 32		Tabor Mfg. Co.	101
Budden, Hambury A.	59	Garvin Machine Co.	Montreal Machy. & Supplies 32		Tallman Brass & Metal Co. 104	
Butterfield & Co., Inc.	89	Geometric Tool Co.	Morse Chain Co.	81	Taylor Instrument Co.	95
Canada Machinery Corporation 101		Gerstner & Sons, H.	Moylen Tool Co.	93	Toledo Machine & Tool Co. 25	
Canada Wire & Iron Goods Co. 64		Gibb Instrument Co.	Morton Mfg. Co.	61	Tivani Electric Steel 99	
Can. E. K. Morton Co.	4	Globe Machine & Stamping Co. 72	Muir Wm., & Co.	63	Toomey, Frank A.	70
Can. Fairbanks-Morse Co.	24	Goodley & Edmund 75	Murdoch Machine & Tool Co. 87		Toronto Iron Works 99	
Can. Fallings & Spencer 134		Grant Gear Works, Inc.	National Machinery Co.	103	Toronto Type Fdry. Co.	115
Can. Desmond-Stephan Mfg. Co. 32		Grant Mfg. & Machine Co. 82	National Machine Tool Co. 191		Toronto Welding Co. 59	
Can. Drawn Steel 100		Greenfield Machine Co.	New Metal Tool Steel Co. 70		Union Drawn Steel Co.	101
Can. Economic Lubricant Co. 79		Hall & Sons, J. H.	New York Machinery Exchange 70		Union Tool Chest Works 99	
Can. Hanson & Van Winkle Co. 27		Hamilton Gear & Machine Co. 97	Nicholson File Co.	107	United States Electrical Tool Co. 93	
Can. Ingersoll-Rand Co.	39	Hanna & Co., M. A.	Niles-Bement-Pond, Inside front cover		Vanadium Alloys Steel 6	
Can. Inspection & Testing Laboratory, Ltd. 101		Hawkinge Bros.	Noble & Westbrook Mfg. Co. 99		Victor Saw Works 26	
Can. Metal Products 101		Hawkesbury Board of Trade 102	Northern Crane Works 99		Vulcan Crucible Steel Co. 10	
Can. Steel Foundries, Ltd. 7		Hendey Machine Co.	Norton, A. O.	193	Walcott Latho Co.	10
Can. Welding Works 33		Henderson, John T.	Norton Co.	33	Webber Bros. Mach.	64
Can. Westinghouse Co.	69	Hobart-Rogers Machinery Co. 94	Nova Scotia Steel & Coal Co. 6		Wells Bros. Co., of Canada 32	
Carter Welding Co.	61	Hyde Engineering Works 89	Oven Equipment & Mfg. Co. 75		West Tire Setter 24	
Cataract Refining Co.	72	Ideal Tool & Mfg. Co.	Parmenter & Bulloch Co.	102	Whiting Foundry Equipment Co. 84	
Chapman Double Ball Bearing Co. 79		Independent Pneumatic Tool Co. 115	Peck, Stow & Wilcox 59		Whitton Machine Co., D. E. 102	
Chesterman, Jas., & Co., Ltd. 13		Iron Works, The 59	Perrin, Wm. R.	25	Williams, A. R., Machinery Co. 55 & 7	
Cincinnati Milling Machine Co. 91			Pressless Machine Co.	23	Williams, J. H., & Co. 23	
Cincinnati Pulley Machy. Co. 86			Petrie, of Montreal, Ltd., H. W. 19 and 6		Williams Tool Co. 28	
Cleveland Twist Drill Co. 19			Petrie, H. W., Ltd.	67	Williams & Wilson 66	
Cleveland Wire Spring Co. 63			Philadelphia Gear Works 59		Win'sor Mach. & Tool Works 61	
Cook, Asa S.	102		Plossville Foundry 109		Winnipeg Gear & Engineering Co. 109	
Cullen Machy. Co., C. W.	69		Positive Clutch & Pulley Works. 103		Worth Engineering Co. 59	
			Pratt & Whitney Inside front cover		Zenith Coal & Steel Products Co. 103	
					Ziu-Ho, Mfg. Co.	75

Safe Practice at Blast Furnaces and Its Development--I.

By Frederick H. Willcox

In its efforts to increase safety in the metallurgical industries, the Bureau of Mines, Washington, D.C., has been studying the causes of accidents at blast furnace plants also methods for their prevention. This article describes the known dangers and makes suggestion of means whereby the risk of accident may be lessened or, better still, wholly avoided.

IN all efforts to reduce accidents, the management should take the leading part. If officials believe that accidents can be prevented, and show a determination to prevent them, the rest of the force will reflect that attitude. Improvement in carefulness follows insistence on safety, as increase of output or reduction of costs follows insistence on efficiency, and for the same obvious reasons. In either case, the management must make special efforts to effect improvement, either by employing experts or by having the department heads make special study of safety conditions, and must supply necessary funds, for rarely or never can improvement be effected without the means to make necessary changes in plant equipment. It is

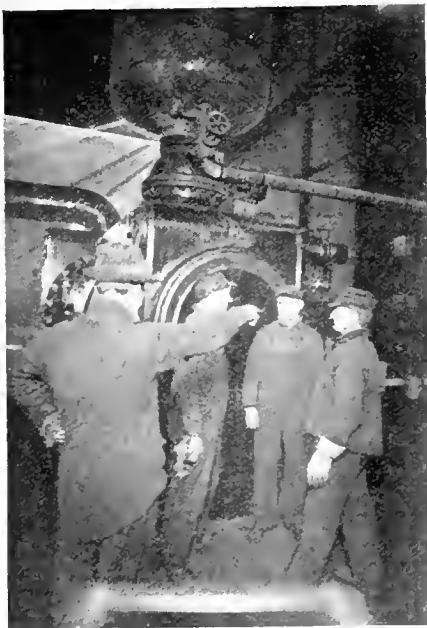

FIG. 1—FOREMAN WARNING MEN AWAY FROM CYLINDER HEAD OF STEAM ENGINE

true that all safeguards do not pay a direct financial return by preventing the accidents for the reduction of which they are installed. It is just as true that these same safeguards do pay when supplemented by other accident-prevention methods, because they show that the company is in earnest in its efforts to reduce accidents, by accepting the responsibility for cause entirely within its control.

If the management gives tangible evidence of its interest in safety, and consequently has aroused the interest of the rest of the force, the foremen can do more to lessen risks and reduce accidents than any other group of men in the

plant. As the foremen, in plant practice, organize the force for co-operation and efficiency in plant operation, and train themselves to observe and analyze the causes of trouble with mechanical equipment or furnace practice, so is it necessary for them to organize the force and train themselves for the best results in accident reduction. Although in blast-furnace works, defective plant arrangement or design, insufficient instructions, and lack of safeguards are sources of accidents, a considerable proportion of the accidents are, nevertheless, due to carelessness, thoughtlessness, ignorance, and clumsiness. However, men can not be expected to be always alert for obscure dangers, to adopt new practices that aim to put safety on a par with quickness or convenience, or to be thinking about not taking chances that rarely result in accident, unless their foremen exhibit as much personal interest, co-operation, and attention to details of work and equipment relating to accident prevention as they do in matters of practice.

The Foremen

To prevent all accidents about furnace plants, to eliminate them entirely, is impossible because many accidents happen by chance and are accidental in the most literal sense. To bring about a permanent reduction, however, does not require great study, analysis, or planning. The methods used to get out the tonnage, the incentives to good practice and maintenance of equipment, and the precaution against incompetence can be applied equally well to avoiding accidents from ignorance, carelessness, awkwardness, or unnecessarily hazardous conditions.

Should two or three tuyeres burst, or a blowpipe and cooler burn every day, or a certain bearing get hot every week, or an armature burn out persistently every month, or a car becomes derailed on a certain curve frequently, some one "gets busy" and finds out the trouble, whether mechanical or personal. To make a record in tonnage, it is not sufficient to go to the blowing room and "put the wind up," a get-together spirit is necessary. If a furnace has to be repaired every crew and foreman should understand and co-operate in the work. Any unusual and dangerous task is given constant personal attention. Such work is not done by making a preliminary inspection, preparing recommendations, and warning the men of the hazard; one or more foremen are on the job to have the work done safely. Past experience and common sense require this. However, the percentage of accidents from asphyxiation, break-outs, explosions, or slips is very small compared

with the percentage of accidents that happen in regular daily work. Dozens of accidents are repetitions of the same circumstances, the cause, nature, and result being essentially identical.

Accident prevention should be handled in the same way as operating difficulties. If it is going to cost more to pay for accidents than to prevent them, if the prospect is that every fourth, sixth, or tenth man in the plant will lose 20 to 35 days' work every year by accident and during that time be replaced by a less skilled employee who will have to be trained and will possibly cause vexatious delays and mistakes, and if better and safer working conditions attract better men, operating methods and instructions should be applied to the

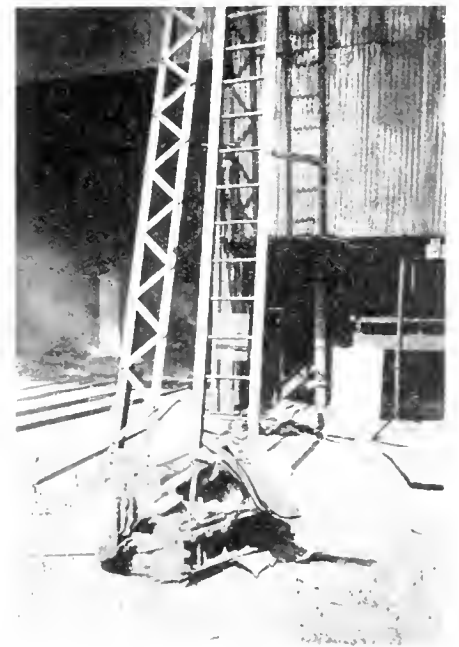

FIG. 2 SCRAP PILED AT FOOT OF LADDER

safety problem. The same methods that have been developed for efficiency may be used to increase safety.

Responsibility of Safety Inspectors

Safety inspectors are invaluable for looking after recommendations, investigating accidents, pointing out possible improvements in equipment and methods, and organizing safety work, but if there is an inspector at the plant do not put the responsibility for betterment on him. His suggestions can no more eliminate accidents than suggestions can eliminate off-grade iron unless his recommendations, as well as the foremen's, are followed by improvements, detailed

instructions, co-operation, and personal supervision. Moreover, if the safety inspector is not familiar with operating methods in detail, there are scores of hazardous places and practices that he will become familiar with only as accidents happen. Accident prevention is too big a job for the safety inspector unless he has the cordial co-operation of the foremen.

Plant-inspection Committee

From the sub-foremen and workmen, a plant-inspection committee of two to four men should be selected and entrusted to inspect the plant every month on a certain date, one man being replaced each month or two months, thus keeping a working nucleus of experienced men on the committee. Each sub-foreman should serve on the committee, as it may be assumed that these men have obtained promotion by displaying qualities that will be as valuable in promoting safety as in developing efficient operation. Select the workmen on the committee from those who are familiar with their work and give some promise of being permanent employees, as only a certain percentage of a plant crew can be considered a permanent asset. These men should be given opportunity to serve on the plant committee and be drawn in turn from the cast house, stock house, trestle, boiler house, and all parts of the plant.

Duties of the Committee.

The work of the inspection committee may be laid out under three heads:—

1.—Study of the accidents that have happened during the preceding month. After the committee has examined an

report for the superintendent's information.

2.—Inspection of the plant for improper physical conditions. These conditions may include insufficient lighting, uncleanness, refuse and debris under foot and overhead, slippery places, holes, lack of railings, overhead obstructions, poor walks, unguarded machinery, insanitation, and so on. Experience has shown that this field is the one most likely to receive attention from an inspection committee. It is unnecessary to give detailed instructions here, as in all probability 75 per cent. of the recommendations of the committee will at first concern this phase of the work.

3.—Inspection of the plant for unsafe practices. Especial emphasis should be placed on this feature of the committee's duties. Men engaged in accident prevention estimate the proportion of accidents due to the neglect of the worker at 40 to 70 per cent. Emphasize the meaning of these figures and encourage attention to this side of accident prevention. Insist that at least half of the time devoted to inspection be spent in observing operations, such as unloading or handling material, casting or pouring, method of using and condition of hand tools, condition of ladders, trestlework, and repair work. The big accident problem is unsafe practices, and these are largely a result of ignorance, carelessness, thoughtlessness, lack of instruction, lack of supervision, and mistaken eagerness or haste in accomplishing work by taking uncalled-for risks. Bettering methods of work as related to accidents is an unlimited field for the committee.

4.—First-aid instruction. Have the men on the plant committee devote as

and how much good is accomplished by the above means are problems that largely solve themselves. Safety is a matter of common sense, foresight, and carefulness. Accident reduction is not insured by committees any more than larger production would be; their purpose is to arouse the interest of every man in be-



FIG. 4—SAFEST WAYS OF RIDING ON RAILROAD CARS

ing watchful. Men will feel an interest in a particular subject and pride in their own work if they are given responsibility and their advice accepted. Their thoroughness in inspection work and conscientiousness in reporting will largely depend on the attitude of the superintendent and foremen. If they treat the matter lightly the men will do likewise, but, if they show a desire to lessen accidents, the men will respond and will take the necessary precautions. It is hardly correct to assume that any reduction in accidents is of benefit to the workmen alone, as compensation or liability insurance are factors to be considered. Some form of appreciation of the workmen's efforts has usually been found essential and productive of results. The form which this appreciation should assume is for the management to decide. The following methods are suggested:—

1.—The use of a "suggestion box" in which any employee may place a signed suggestion for promoting safety. Reward the best suggestion with a substantial token such as a cash prize, watch, technical book, tool, or subscription to a trade journal. The award should be made monthly if practicable.

2.—Divide the various crews under the different foremen into divisions, and to each division that has no lost-time accidents for one to three months, or has reduced its percentage of accidents in that period, give a prize such as cigars, and award the foreman a cash bonus or a prize. In case the accident percentage rate is taken as the basis, it may be ad-



FIG. 3—A DANGEROUS PRACTICE, CLIMBING BETWEEN CARS

accident report it should confer with the foreman in charge, the injured man, the man who caused the accident, any witnesses, and visit the place of the accident and see how the work is done. The comments and recommendations of the committee may be attached to the accident

much time as is necessary to the study of first aid, such as bandaging, stretcher drill, and resuscitation methods.

Obtaining Co-operation and Recommendations

How much real interest is induced

visible to take the accumulative rate, rather than the flat rate for each distinct period. The names of those who win the awards should be posted, together with the records on which the awards were based.

Foremen's Committee

The chief foremen, such as the general foreman, master mechanic, electrician, and yard or labor foreman, and any other foremen desired, should meet with the superintendent or assistant superintendent once a month for the purpose of discussing accident prevention.

At this meeting discuss each accident that has happened during the preceding month. Find out the cause, whether negligence of employer or employee, or trade-risk, and whether the accident was preventable and could have been avoided by safeguards, by instructions, by different procedure, or by more care. Use the notes of the plant-inspection committee, and if feasible have the injured man, an eye-witness, or the sub-foreman describe the accident and find out how he thinks it might have been avoided.

Should this conference with the men be made a basis of discipline, it will discourage frankness. Discipline concerns carelessness and incompetence, and this question should be decided outside of and previous to this meeting. If the accident seems to have resulted from ignorance it should be the duty of the sub-foreman to explain why the man was not instructed and to see that the men are told of this danger and of a safe way of doing the work. If the accident is due to your own oversight be frank to say so; this will not destroy discipline. If the accident is clearly due to the lack of

effect immediately or explain why it is not feasible—for instance, because it interferes with something else, must be postponed until relining, may not serve the purpose, or will cost too much. It can be accepted that many railings, toe boards, guards, steps, and signs will be

that relate solely to plant operation. It has been found feasible, assuming that these committeemen are selected by reason of their rank, experience, or intelligence, to make them gang safety leaders and to give them some little authority and responsibility in matters relating to



FIG. 6 SAFE AND UNSAFE SHOES

suggested, and that there will be futile recommendations. Before disapproving a committee's recommendation because of the cost, refer it to the management. It will prove worth-while to concen in many apparently trivial suggestions, to avoid discouraging the men offering them and to encourage the submission of really valuable ideas. If a different method of work is recommended, try it if it seems practicable. If it is thoroughly impracticable or useless and cannot be tried, explain why.

Putting Recommendations into Effect

After the plant-inspection committee recommendations have been accepted and approved by the foreman's committee, they should be submitted to the superintendent for approval. Approved recommendations may be put into effect in two ways. The inspection committee may locate the accident risk most thoroughly, but the design and installing of adequate mechanical safeguards is work for a skilled mechanic who has the advice of men familiar with the particular risk. To delegate the responsibility for and installation of a safeguard to a group or a committee is to make it nobody's business. Place the responsibility for this on the master mechanic.

Recommendations that deal with unsafe practices are largely made effective through education and by example. Therefore, each active or past member of the inspection committee should be made to feel that it is as much a part of his daily task to work for safety by setting a good example, giving warnings, supervising the work, and contriving how to accomplish the intent of safety recommendations, as it is to execute duties

elimination of accident risk in methods of doing work. If this is practicable locally, it is a more desirable recognition of committee service than a "safety" lapel button or watch fob, and more effective in sustaining interest. The button or fob is useful chiefly as a token of such responsibility.

Responsibility of the Foreman

The final responsibility for safety work cannot be placed on committees, gang leaders, or workmen. Practicable results in safety cannot be obtained in that way any more than a plant can be run on such a basis. To put safety work on a sound and sensible basis the foreman must give the subject serious observation, study, planning, and direction, such as is given to operating work. The safety of the workmen always has been given foremost attention by foremen, but the reduction in accidents effected by many companies indicates that this attention has been concerned more with obviously dangerous factors than with injuries due to hand labor, use of hand tools, falls, falling objects, and similar causes incident to daily work. To these causes, however, the greater part of blast furnace accidents is due. Following are the causes of accidents at blast-furnace plants, arranged in the order of their importance:

1. Hand labor.
2. Hand tools.
3. Plying and falling material.
4. Falls of person.
5. Burns from hot metal.
6. Machines and machinery.
7. Cranes, hoists, and rigging.
8. Hot water and steam.
9. Burns from cinder.



FIG. 5 UNSAFE WAYS OF RIDING ON RAILROAD CARS

a safeguard see that the safeguard is placed promptly, though the accident may be the first one of its kind in years.

Go over the recommendations of the plant-inspection committee, note each safety measure suggested, and put it into

10. Flames.
- 11.—Railroads.
- 12.—Asphyxiation.
- 13.—Slips.
- 14.—Illness (including intoxication).
- 15.—Hot flue dust.
- 16.—Electric machinery.
- 17.—Explosives.
- 18.—Fighting and playing.

If burns from hot metal and burns from cinder were grouped together they would rank third. Hand labor and hand tools cause over 40 per cent. of all accidents; if flying and falling objects and falls of person are included, over 60 per cent. of all accidents are represented; and if burns from hot metal and cinder are added, the total represents approximately 75 per cent. of all blast-furnace accidents. This shows where the accident problem lies. Effective prevention of accident from these causes requires study, observation, experience, and instruction. No one in the plant is more capable of doing this than the foreman, no one is in such close contact with the men, and no one can combine such work with operating supervision so advantageously and effectively.

Precautions to be Observed by Foremen

The following suggestions, which cover the dangers incident to different kinds of work about the blast furnace, are not intended to serve as rules, but as useful memoranda to foremen and workmen. It is not necessary to call in the men and discuss this matter with them from beginning to end; it is even of questionable benefit to call a crew together at their place of work and repeat a long string of "don't's"; precautions can better be impressed on the men gradually and at opportune times. As the precautions given in these notes gradually come to be subconsciously in the minds of both foremen and workmen at their work, to that degree will the number of accidents permanently decrease.

Avoid employing a man whose language no one of your crew can speak. Do not place a slow, heavy man where a quick, active one is required, or a slow-thinking man where a quick-witted one is required, nor keep on the same job a man who gets hurt frequently in that occupation unless the labor supply is inadequate or men cannot be shifted. When a man is employed or put to work on a new job instruct him as to his work and how to avoid accidents, warn him of unusual or obscure danger, and then put him under the charge of the gang leader or "straw boss." You should consider yourself personally responsible for accidents that happen to your men from their ignorance of danger or of safe methods. Therefore, watch for dangerous practices, ignorance, lack of skill, and

carelessness, and take the necessary steps to correct faults when first noticed. Most men can be taught and encouraged to use proper methods of work, but when necessary impress on the men by admonition, warning, suspension, or discharge your attitude against carelessness or indifference. Drill your men to report immediately when injured, however slightly; send an injured man to the doctor or first-aid man, and then investigate the accident at once and discuss it with the sub-foreman and workmen in order to bring out clearly the cause and impress it on their minds.

Where it is possible, make dangerous places safe rather than attempt to guard them with signs. Where signs are necessary accept the responsibility for placing them, see that they are in good condition and that they are used. Make it your business to see that machinery,

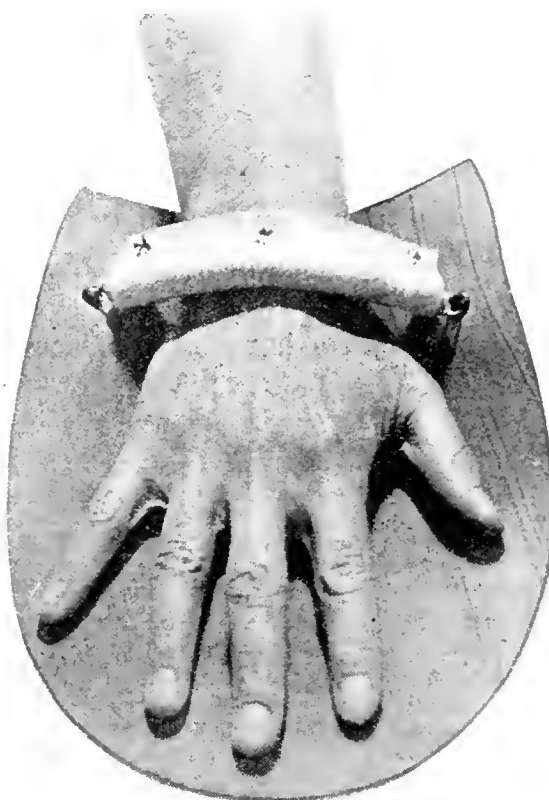

FIG. 7.—SAFETY HAND LEATHER

hand tools, tackle, scaffolds, or any other appliances are safe. Do not allow men to start or operate machinery unless they are so authorized. Avail yourself of all safeguards provided for the men under your direction, such as goggles, leggings, and congress shoes, when on duty about the cast house or pig machine. Exhibit carefulness in necessary personal work with machinery, electrical and steam equipment, and hand tools. Place and use prescribed safeguards or signs. In this way you will be better able to insist that the men under you observe similar precautions.

Personally supervise any work involving unusual accident hazard, such as work in gas mains or cleaners, tearing

out linings, work in the cast house and about the stoves, when blowing in or blowing out, or in event of a bad "mess" (piles of red-hot coke, slag, or iron spilled about the furnace, or in the yard, or on the tracks near the cast house), and any work about the bells or stock line. Don't allow men to go into any place dangerous from gas, falls, or falling material without breathing apparatus, safety belts and life lines, or watchers, as the nature of the work demands and circumstances permit. Never send inexperienced men to dangerous places or set them at hazardous work. Before sending or allowing men on top or where they will be exposed to material from slips, and escape is difficult, make sure that the furnace is not hanging. If the furnace is working stiff or slipping, the necessary precautions should be taken in regard to checking it or taking the wind off temporarily. Recognize that work about blast-furnace plants will still be hazardous, even after all safety measures have been taken and the force is at the "top notch" of training, skill, and carefulness. Impress this fact on the crew and insist on thorough instruction and care of every man by his gang boss.

On occasions, you will have to give detailed advice and directions to the workmen concerning dangers not here described. The more common dangers arise in work about gas-containing equipment, work about the furnace in event of a breakout, heavy scaffolding and slipping of the furnace, stopping the furnace, blowing in, losing the water supply, and so on. Many other hazardous operations will occur to you. For such work a set of rules or notes intended for some particular plant conditions are futile or may even be dangerous unless varied to meet the situation. When unusual situations arise, safety depends on the measures taken by the foreman. Experience, coolness, and common sense are more essential than rules. Certain emergencies can be largely eliminated, however, by careful examination,

forethought, and planning before undertaking dangerous work. At most plants it is the rule that, before any dangerous work is done, the superintendent and foremen together definitely determine the various steps to be taken. This should be the rule at every plant.

Following are some notes addressed to men in various occupations about the plant. Many of the men will be experienced in the different positions and know of all the principal dangers and practices mentioned. With such men all that is necessary is, when you notice them becoming careless or forceful, to show them wherein they are becoming careless. In placing new men it is worse than useless to give them a large number of

instructions as they will only be confused. Keep these notes in mind and give them general instructions and any special instruction you think they need at first. Then continue to instruct them from time to time and have the "straw boss," gang leader, or sub-foreman do the same. Personally supervise their work as much as possible, and take advantage of every opportunity to forcibly impress on their minds the advantages of safe practice. More and more, managements are valuing foremen by their care of the men as well as by their records for tonnage and cost. Keep the safety of your crew in mind always, and when you think of some new precaution in work or practice refer it to the superintendent at once and try to have it put into effect.

General Observations

If you see anyone in a dangerous place (Fig. 1), doing anything in a way liable to injure himself or others, clumsy in the use of tools, ignorant of danger, or ignoring the use of safeguards or safety rules, show him the danger and report the case if your warning is disregarded. Report at once unsafe equipment or tools, safeguards, or signs not in use or not replaced, and dangerous places unguarded. Watch other men's work for dangerous or unsafe methods, but be careful that your own work is done safely.

Keep things cleaned up. This is part of your work. Don't leave tools or materials on floors, platforms, or paths where they will obstruct work and make passage difficult (See Fig. 2). Take time to keep the steps and platforms you have to use free from ice, and to knock down overhanging icicles. Take care of the odds and ends of lumber, scrap, brick-bats, coke, limestone, and ore you find about the yard. The majority of falls are on the ground level and are largely caused by rubbish underfoot. Watch where you step. Do not walk through steamy places unless it is necessary; if

you must go, walk slowly. Don't work where your material or tools can drop without being sure that the space below is guarded by danger signs. On the other hand, don't walk where you know that material may fall on you; remedy the condition if possible.



FIG. 8 TAKING CHANCES ON A LADDER

In handling material such as ties, lumber, brick, bronze, castings, molds, plates, manhole covers, pipe, barrels, boxes, scrap, and pig iron, watch that nothing falls on your foot and be careful that your fingers are not caught. A large percentage of the accidents in blast-furnace plants happen in handling material. In using bars, sledges, wrenches, picks, and other tools, remember that many accidents occur by men being struck with them. Glancing, slipping, and falling tools cause still more accidents. In using common hand tools more skill and care is required to avoid accidents than with many kinds of machines.

Keep away from tracks if possible. If it be necessary to cross a track look both ways before starting across. If you must cross near a train, keep at least a car length from the end of the train, as it may start quickly, or there may be cars coming on the next track. Do not cross through a broken train unless the trainman motions you to come ahead or unless you are sure that there is no engine at either end. Take time to go around a train or to wait until it passes, rather than to climb through (Fig. 3). Never crawl under a car. Avoid stepping on frogs, switches, or guard rails, as your foot may be caught. Don't move material with push cars unless guarded by a flag, and when working where a car might be shoved on to you, have a flag guarding the track approach. Don't ride on engines, cars (Figs. 4 and 5), or locomotive cranes, unless your job requires you to do so.

Shoes should fit snugly about the ankle and leg, and the soles should be thick

and free from holes that will allow the sole of the foot to be cut by sharp objects and protruding nails. (See Fig. 6). Whenever you see protruding nails stop and hammer them flat. In handling rough lumber, sheet tin, or material having sharp edges, it is best to wear stout gloves. For handling rough scrap wear safety hand leathers (Fig. 7), not gloves, because in throwing the scrap down the rough edges may catch in your gloves and cause a bad wrench or fall.

Ladders should be provided with spikes or nonslipping pads and when in use should rest squarely on a level surface. Grasp the sides, not the rungs, of the ladder and face the ladder in going up or coming down. Don't attempt to slide down a ladder or to use one hand to carry tools, either ascending or descending. (See Figs. 8 to 10.) Defective ladders should be taken to the carpenter shop at once.

Defective tools should be taken to the shop as soon as the defect is noticed. Do not use a sledge, hammer, pick, or hatchet that is loose on the handle, has a mushroomed head, or a split or splintered handle. Bars and wedges should also be watched, and, if any defect be noticed, be laid aside for repairs. When sledging stand on the opposite side from the man holding the bar, so as to avoid hitting him. (See Figs. 31 and 32 in following issues).

Do not meddle with electric switches, water or steam valves, or gas connections; it may cause delays and even a bad accident. Do not touch any electric line or dangling or broken wires; you may get a severe electric shock. Wear gloves when changing or cleaning electric-light bulbs. Never turn on gas, steam, electricity, or water, or set machinery in motion with which you have no regular business unless you are specifically directed to do so.

Be watchful about the furnace. Gas may be escaping in many places and may



FIG. 9 MAN FALLS FROM LADDER



FIG. 10 THE SAFE WAY

kill you before you know it is present, the furnace may slip, the bosh or hearth of the furnace may break out, a tuyere may burst, or a blow pipe burn through, or there may be an explosion. Keep out of the east house except when your work calls you there. The furnace crew can sometimes tell when these things are about to happen by signs with which they are familiar; at times they happen without warning. Stay at your own work and be safe. Keep away from the bottom of the dust eaters, from under the downlegs of gas mains, and off of manhole covers of gas flues. Avoid iron and cinder ladles while they are being filled, shifted, or poured. Do not go near a cinder granulating pit while it is in use and do not stand about gas burners or air doors of stoves. Never go on top of a furnace or gas washer unless under the direction of the foreman, or accompanied by some one. The tops of boiler settings, gas-engine basements, skip pits, and ore bins should be avoided unless your work take you there. Before you begin work in such places, or in any place where there is a possibility of danger, wait until the foreman has told you that it is safe to go. Satisfy yourself that the place has been made as safe as possible. Never look in the peep holes of the tuyere stocks unless it is part of your duty. Always be on watch when passing near the furnace. Remember that frequently it is impossible for the furnace men to tell when the furnace is going to slip.

Do not refuse safeguards, do not ignore rules and orders, or disregard danger signs. There is a reason for each and every one. Be sure to report every accident, even the slightest burn, cut, bruise, puncture, or substance in the eye, as this may prevent a trivial hurt from becoming a serious injury. Do not set bad examples by bravado, thoughtlessness, or negligence, for less experienced men to follow. Use common sense, foresight, and watchfulness. Those who cannot read and speak English should be urged to acquire a working knowledge of the language at the earliest opportunity. By so doing they will be in a better position to heed warnings and become acquainted with dangerous practices.

COMMERCIAL ACCURACY IN STANDARDIZED PARTS

THE wisdom of accuracy in designing and manufacturing parts was the object of some interesting remarks by F. W. Lancheater, in the course of a recent paper on "Worn Gear and Worn Gear Mounting." In the course of his remarks, he said that he had never found it cheaper to work to a low degree of accuracy than to work to a high degree of accuracy; a thrust bearing can be produced which from face to face does not differ by more than a thousandth just as cheaply as it can be produced to within two or three one-thousandths. Whatever difference of cost there may be is more than compensated for by the advantage of interchangeability. The ac-

tual production of a part accurately to dimensions that, is to say, within fine limits, may be slightly greater, but in any complex piece of machinery the saving in cost of assemblage will pay the bill many times over. * * * Some years ago, in designing certain mechanism every clearance dimension and tolerance dimension was set personally by the author's own hands, and these were worked, too, for a considerable time with satisfactory results. A new works manager, who did not believe in working to fine limits, reported that the limits were unduly fastidious and that money could be saved by relaxing the limits and so avoid having to scrap parts. The managing director consented and the scheme was tried. A slight and questionable reduction resulted in the cost of manufacturing components, but the increased cost of assembling and testing, and the cost of rectifying complaints, etc., became so great that the initial saving was swallowed up many times over. Within twelve months the scheme was abandoned and the old fine tolerances were restored, the expense of twice altering the gauges, etc., being a dead loss, apart from the disastrous results of the experiment.

EMPIRE MINERAL RESOURCES

THE extent to which the British Empire is dependent on foreign countries for the supply of certain countries for the supply of certain non-ferrous industrial metals, and methods for reducing such a condition were among the principal points dealt with by Dr. C. G. Cullis before the Society of Engineers in London last month. Of the fine leading metals, copper, lead, zinc, tin and aluminum, tin was the only one in which our position was at all satisfactory. The British mine production of tin in 1912 was 66,000 metric tons out of a world's total of 125,000, and the smelter production of 85,000. Estimating the consumption at 32,500 tons, there remained 53,000 tons for export. The closing of the German market for Bolivian tin ore had given rise to an opportunity for securing the whole of the Bolivian output for British smelting.

With regard to copper, not only were the ore resources, as at present exploited, deficient, but the smelting facilities also were seriously inadequate for the Empire's metal requirements. The production both of ores and metal could be substantially increased by suitable organisation and administration.

Lead and zinc ores, raised in British territory, had in the past been exploited on a large scale to foreign countries, notably Germany and Belgium, for metal recovery, with the result that the Empire had been placed in an anomalous position of dependence which ought never to have arisen. The shortage of zinc, in the early days of the war, and the consequent jeopardising of supplies of cartridge-brass were referred to. The mine production of lead and zinc was more than sufficient for the Empire's

requirements, but the smelting facilities were lamentably deficient, especially in the case of zinc. It was urged that all the lead and zinc concentrates of Broken Hill should in future be smelted within the Empire.

In the case of aluminum, while the actual bauxite resources of the Empire were so small that dependence had to be placed upon the French or American deposits—which were being more and more utilised in their countries of origin—large potential supplies, in the form of laterite, had a very wide distribution in the tropical colonies, but were almost untouched and untried. The systematic examination of these and other potential sources of aluminum, with a view to their utilisation, was seriously needed.

CENSUS OF MANUFACTURES

THE total census of manufactures in Canada during 1915 shows that the number of establishments has increased during the last decade from 15,796 to 21,291. The census was taken during 1914.

The total capital (including value of land, buildings, machinery, materials and stocks on hand and operating capital, owned or borrowed) has advanced from \$846,585,023 to \$1,984,991,427, or 134.47 per cent.

The total wages bill has likewise increased from \$134,375,925 to \$227,508,800, or 69.31 per cent, and the salaries bill from \$30,724,086 to \$60,143,704, an increase of 95.75 per cent. The value of products in 1915 was \$1,393,516,953, an increase of \$674,164,350 over 1905, or 93.85 per cent.

The total value of goods manufactured for war purposes actually completed and delivered during 1915 amounted to \$130,466,307, a total which it is expected will be increased by several millions in the final return.

FOUNDRYMEN'S CONVENTION AND EXHIBITION

THE Annual Convention of the American Foundrymen's Association will be held at Boston, Mass., during the week of Sept. 24. Concurrent with this meeting will be conducted the exhibition of foundry equipment and supplies, machine tools and accessories in the Mechanic's building, which affords a display floor area of approximately 80,000 square feet.

This is the second time in the history of the American Foundrymen's Association that it has selected New England for its meeting place, the previous Convention having been held at Boston in 1902. At that time, the membership of the American Foundrymen's Association was only a few hundred, whereas at present the enrolment is considerably over 1,000. In addition to the meeting of the American Institute of Metals will hold its Annual Convention at the same time and place.

EDITORIAL CORRESPONDENCE

Embracing the Further Discussion of Previously Published Articles, Inquiries for General Information, Observations and Suggestions—Your Co-operation is Invited

PRELIMINARIES IN MACHINE PART PRODUCTION METHODS—II.

By F. Scriber.

THE illustration, Fig. 4, shows a thumb screw, which is five inches long by $\frac{7}{8}$ -inch largest diameter, made from tool steel on a hand-screw machine, the cuts be-

LIST OF TOOLS	
Name of Subject <i>Thumb screw</i>	No <i>3924-S</i>
Date <i>May 18, 1916</i>	By <i>F. S.</i>
Sketch of Subject	
Material <i>Tool steel</i>	
Machine <i>Hand screw mach.</i>	
Operation	Tools Required
<i>Draw from bar stock 7/8 diameter</i>	<i>Chuck</i>
<i>Locate for length</i>	<i>Plug in first hole</i>
<i>Turn thread to shoulder</i>	<i>Box tool</i>
<i>Turn two 3/8 diameter</i>	<i>Cross slide tool (front)</i>
<i>Cut groove 1" (rough)</i>	<i>Self opening air</i>
<i>Thread cut off</i>	<i>Cross slide (rear)</i>
2nd Operation	
<i>Drop on 1/2 diameter beyond thread</i>	<i>Spring collet</i>
<i>Turn knurled portion</i>	<i>Turning tool (knurl type)</i>
<i>Finish groove neck & form end</i>	<i>Special gross slide tool (maker)</i>
<i>Knurl</i>	

FIG. 4

ing made in the usual manner in the order enumerated on the "List of Tools." Likewise Fig. 5 shows another part which is made on a screw machine, the machine in this case being automatic. The name of the subject is sleeve, No. 912-C, and this is machined using tools

LIST OF TOOLS	
Name of Subject <i>Sleeve</i>	No <i>912-C</i>
Date <i>May 18, 1916</i>	By <i>F. S.</i>
Sketch of Subject	
Material <i>Screw steel</i>	
Machine <i>Screw mach.</i>	
Operation	Tools Required
<i>Draw from bar stock</i>	<i>Drill and cutters held in box tool</i>
<i>Drill large hole</i>	
<i>Turn knurled portion</i>	
<i>Rough turn long end chamfer</i>	<i>Slide chucking names</i>
<i>Diam both holes</i>	
<i>Drill small hole</i>	
<i>Finish turn long end</i>	<i>Same as above</i>
<i>Turn A</i>	
<i>Knurl</i>	<i>Tool held in cross slide</i>
<i>Cut off</i>	<i>Cross slide tool</i>
	<i>Use standard cams</i>

FIG. 5

held in the turret holes and cross-slide in the usual manner.

Regarding Purchased Tools

The method of making up a list of tools as described does very well where the tools are to be made in the factory, where they can be watched, or where a complete understanding of the requirements is in evidence, but if the parts to be machined require special tools and these special tools are to be made by a firm which knows nothing at all about the conditions governing the work, a more definite description of the tools required is advisable.

In Fig. 6 is shown a form of tool sheet which emphasizes such special points which a tool designer would like to know. This sheet is headed "Specifications covering tools to be designed, etc.," the various spaces being filled in as shown. This sheet is complete in itself, and, therefore, need not be gone into fully, but special attention should be paid to the marking of the tool, the condition of the part when ready to be held in this tool and the points from which it is de-

Specifications Covering Tool to be designed and made by		Tool No.
		<i>T-167</i>
For use at <i>2-B Milling machine</i>		
Date of order <i>Dec 1, 1916</i> Order No. <i>11872</i> Tool No. <i>437-DC</i> Part No. <i>4 876</i>		
Purpose for which tool is to be used <i>Drilling</i>		
Model <i>DC</i>		
Name of part <i>Bracket</i>		
Name of tool <i>Bracket Drill bit</i>		
How shall tool be marked? <i>437-DC</i>		
State machined condition of part when ready for the tool <i>All surfaces finished</i>		
Have you found it necessary to locate from certain points on this part? <i>Finish base and top</i>		
Can you furnish a sample part? <i>No</i>		
Number of parts to be machined at one setting <i>One</i>		
Approximate number of parts this tool is intended to produce <i>Unlimited</i>		
Production required per day of ten hours <i>All practical</i>		
Machine on which tool is to be used <i>Drill press</i>		
Design to be similar to tool		
Approximate date for completion <i>2/12/17</i>		
Ship via <i>Express</i> To <i>Canadian Machinery</i>		
Signed <i>F. S.</i>		
Remarks <i>In milling operations before designing this tool</i>		

FIG. 6

sirable to locate the parts, as the design of the tool is largely dependent on these latter conditions, in conjunction with the number of parts to be machined at one setting. The production required in one day will, of course, determine the number of tools or fixtures it will be necessary to make of the design decided upon. Any special requirements not evident from the questions on the sheet should be noted in the "Remarks" column at the bottom of the sheet.

The shrinkage of manganese steel is greater than that of ordinary steel.

HOME-MADE CHECK VALVE FOR BOILER TEST PUMPS

By J. E. McCormack.

IN the course of experiments with home-made force pumps for boiler test purposes, the writer found it convenient to utilize a couple of old globe valves from the scrap, which were quite capable of

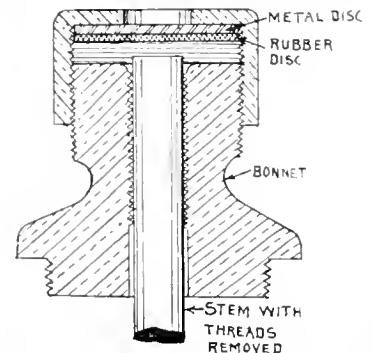

HOME-MADE CHECK VALVE FOR FORCE PUMP.

withstanding the occasional pressure demands without break or leakage, even though not quite suited for continuous operation. Many globe valves, especially those with renewable faces, are ultimately scrapped through failure of threads, either on the valve stem or for the stuffing nut to screw on to. The failure of either of these renders the valve useless for its original purpose, but with a small amount of doctoring it will serve very well as an extemporized check valve.

The first thing to do is to grind the threads off the valve stem so that it will slide freely back and forth in the bonnet without sticking. Now remove the stuffing nut, assemble the parts together and mark the valve stem level with the top of the bonnet, cutting it slightly shorter than the mark, according to the amount of lift desired. A metal disc is now made a fairly close fit for the inside of the stuffing nut, a rubber disc being also made to fit in the same place. The sketch shows the parts assembled, but not tightened down into position. When the stuffing nut is screwed home, the rubber disc makes a tight joint with the top of the bonnet and prevents leakage from the valve stem, the lift of which may be increased at any time by cutting more off the end. Should the threads on the bonnet be badly worn, the top of the bonnet may be cut down some so that the stuffing nut will get a hold of the unworn threads. Should this fail there is frequently enough metal to allow of a standard pipe thread being cut, to accommodate a pipe cap in place of the stuffing nut.

These valves, of course, are not suited for continuous operation, but, when tried out with a force pump on boiler test work at 100 lbs. pressure, operated quite as satisfactorily as entirely new check valves.

LADDER CHAIN AND ITS MANUFACTURE

By F. Scriber

LADDER chain is quite extensively used in the make up of various hardware articles and as its name implies

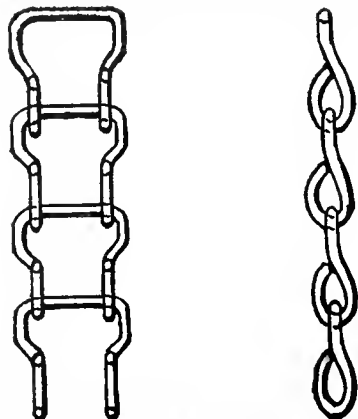

FIG. 1. TYPE OF LADDER CHAIN HAVING STRAIGHT BAR AND LOOPED ENDS.

it is shaped to appear like a ladder; contrary to most chains the ladder chain is flexible in one direction only and cannot be subjected to appreciable twisting movement. This will be readily understood by referring to the illustration Fig. 1, where it will be noticed that both ends of the wire are looped; through both loops the wire which forms the next link is passed, the straight portion on the link representing cross pieces on a ladder while the ends of each succeeding link are made to receive the next link.

As on all formed wire articles where the demand is great enough to warrant it, an automatic machine is used to make this chain, a type of machine

comes from the reel, feeding it forward against the stop and cutting it off the correct length to make a link for the first movements; the second movement is bending the wire to shape, while the final movement is looping the ends.

As each link is completed the wire to make the next link is fed through the loops as shown in the lower view, the finished link being then released by the machine and suspended on the wire while the machine proceeds to make the second link. To clearly bring out the points involved in this operation it is necessary to follow the operations as they are performed by the machine. The various units of the machine are operated by cams and levers from the drive shaft A which is in turn driven by a belt. Referring to the illustration Fig. 4, this shows how the straightening of the wire is accomplished. This straightening process is employed to remove the short kinks which might be found in the wire as it comes off the reel and also to remove the tendency to curl which is in evidence in the wire owing to it having been tightly wound around the reel. In this exaggerated illustration it will be noticed that the wire is bent slightly as it passes between staggered rolls. These short bends have a tendency to remove the elasticity from the wire and it enters the forming machine practically straight, owing to a slight drawing action between the feed slide and the straightening rolls. This illustration shows but four rolls, and an arrangement of these rolls in two groups of seven rolls each set at right angles to each other is shown mounted on the machine at B. The wire is fed to the machine by the oscillating movement of the lever C operated by side cam D, until it strikes a gauge. The wire is now cut off and the forming operations performed by means of tools arranged as shown at the center of the machine, these operations having been described under Fig. 3.

Machines of this type make ladder chain for hours at a time, with hardly any attention from the operator and, consequently, one man can run quite a number of these

for stopping the machine in case the wire should break, and in addition to this these machines are sometimes provided with a bell to call the operator's

FEED AND CUT-OFF

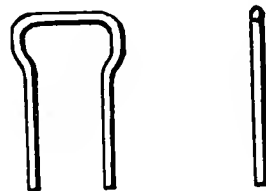

BEND TO SHAPE



LOOP ENDS

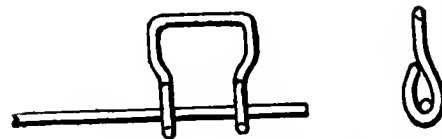

FEED THROUGH LOOP

FIG. 3. SEQUENCE OF OPERATIONS PERFORMED IN MAKING LADDER CHAIN.

attention to the fact that the machine has stopped owing to it having run out of wire or something having gone wrong.

Belt Dressing.—The operation of applying dressing to belts to prevent them from slipping leads to many serious accidents. Care should be taken to apply the dressing at the point where the belt leaves the pulley and to roll up the sleeves so that they will not catch upon belt fastenings or other parts of the belt. It is hardly feasible to stop the belt while the dressing is being applied, because it is then very hard to reach all parts of the belt, and to apply the dressing smoothly and uniformly. The safest

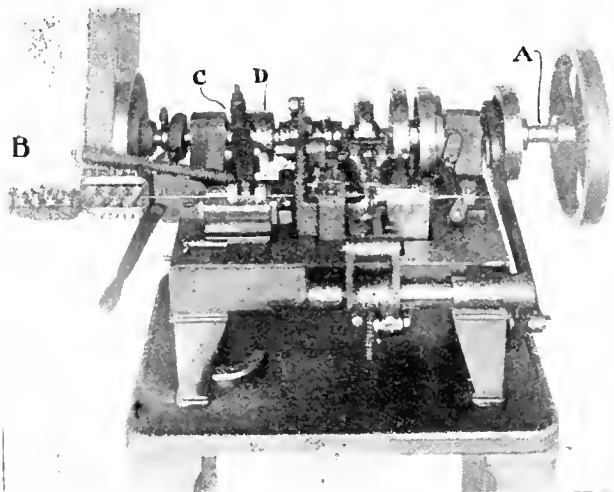

FIG. 2. AUTOMATIC MACHINE FOR FORMING LADDER TYPE OF CHAIN.

suitable for this purpose being shown by Fig. 2, and the operations performed shown by Fig. 3. These operations consist of, straightening the wire as it

machines, his chief duty being to keep the machines supplied with coils of wire, as each machine is supplied with an automatic stop motion

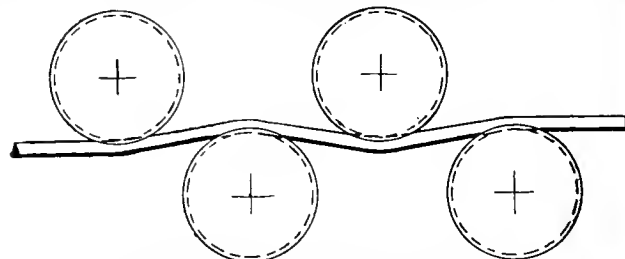
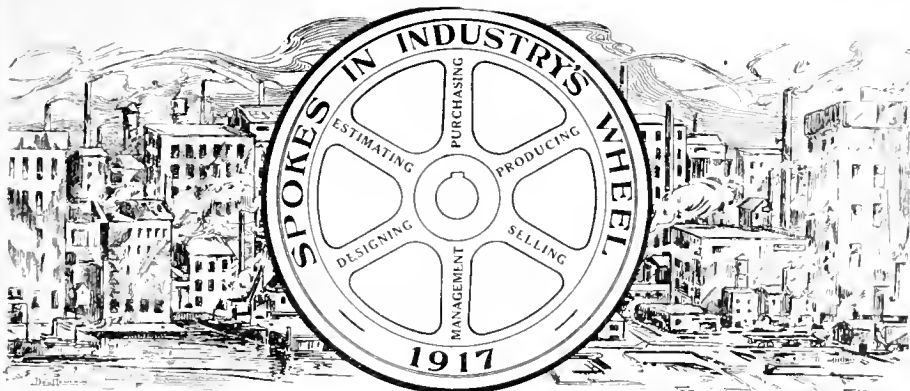

FIG. 4. ARRANGEMENT OF ROLLS FOR STRAIGHTENING WIRE AS IT IS FED INTO MACHINE IN FIG. 2.

and best way, without doubt, is to remove the belt altogether, when it needs dressing, and stretch it out along a bench or on a clean floor.



The constitution of industrial enterprise is largely departmental—"spokes in a wheel." This series of articles has for its object the featuring in a racy, interesting and instructive fashion, the training, experience and achievement of those who to-day are transmitting, effectively, energy in their capacity as "spokes in the wheels" of our metal-working establishments.

FRED W. EVANS

In these days of specialization, when the principal argument in favor of many machines is the feature of "single-purposeness," it is pleasing to turn from the material to the human side of affairs and observe that many in our midst are possessed of this qualification. It is hardly correct, however, to apply this attribute to the subject of these remarks, in its strictest sense, as in order to be single-purposed, he has been many-minded. The former fact is emphasized, however, because, with the exception of some three years spent in gleaning information of a practical and ultimately useful nature, Fred W. Evans has spent his entire career in the service of the Canadian Fairbanks-Morse Co., his duties with this concern having run the whole gamut of activity from ubiquitous junior assistant to the position of branch manager for the company at Toronto.

Fred hails from Montreal, a son of real Canadian soil, having been born in that city on December 8, 1885, of English parents, and, therefore, fully qualified to further in every way the interests of Canada and the British Empire. His early education was obtained at public school, followed by a business college course, after which he spent a few years in the car department of the Grand Trunk Railway system, where he obtained an insight into many of the mysteries of rolling stock. Had Fred been destined for a financier, he might have been tempted to include the watering of stock also as part of his duties, but he smilingly denies any knowledge of that species of railroad engineering.

Be that as it may, Fairbanks-Morse roped him in on June 20, 1904, and have clung to him ever since; and the association has been pleasant and profitable to both parties, as all of his friends know. These same friends, from coast to coast, were glad indeed when his appointment as manager of the Toronto branch was officially confirmed at the close of the past year. They were all agreed that Fred was a good scout, a real brick, but

they did not know perhaps that Fred had absorbed the solid brick quality in his childhood days—his father, Thomas Evans, having been a building contractor, so Fred had every opportunity for distinguishing between the real and otherwise bricks. Perhaps the fact that his father erected chimney stacks and other architectural structures gave him early facility for cultivating the lofty gaze and broad view—termed high ideals by the



FRED W. EVANS

philosophers—anyhow, C. F. M. Co. jumped him around the Dominion in good shape, whilst most of the neighboring States have had the honor of sup porting him on frequent occasions.

While learning the rudiments of the business in a general way our youthful friend was connected with an incident which, perhaps, more than anything else,

is responsible for his presence in the machine tool business to-day. As a matter of fact, Fred broke his way into the machine tool department of the company literally as well as metaphorically. While admiring the beautiful workmanship of a Brown & Sharpe milling machine one evening in the warehouse after hours, his high ideals came to the surface, and Fred tried to see how high the table would elevate. The elevating gear worked like silk, and being single-purposed, he did not worry about anything else but getting that table up high, till snap went the arm braces, and Fred's heart went to his boots; in fact, he swears he didn't have a wink of sleep all night after it.

The next day his heart left his boots altogether when he heard the manager of the department say that if the culprit did not own up, he would be fired. By noon time Fred's heart was in its normal location, and he told the truth so frankly and convincingly that he was invited to be one of the elect and dwell in the region of machine tools which are never out of truth—at least the kind Fred sells, anyway.

The fall of 1910 found Mr. Evans in Winnipeg, where his good nature was imposed on to the extent of acting as consulting equipment engineer for the Winnipeg Technical School, a valuable service on his part, which was duly appreciated in contract form, covering most of the machine tool and wood-working equipment of the institution.

The outbreak of war resulted in his return to Montreal, where he assumed entire responsibility for his firm's machine tool business throughout the Dominion, a task which rapidly assumed very large dimensions as a result of the company's dealings with munition manufacturers, and which was doubly difficult because of the experimental stage through which everything and everybody were then passing.

Munition developments in the Toronto field resulted in his joining the staff there in the fall of 1915. In March, 1916, he was appointed acting manager of that branch, and recently was confirmed in that position as permanent successor to his late friend and predecessor, Capt. Frank Newman.

Although a comparatively newcomer in the Queen City, Fred dwelt here in spirit years ago—perhaps that's why he liked to speak so much of the "Queen" City. Mrs. Evans was formally Miss Edna M. Hurd, of Toronto, and has shared Fred's roof, rain, and shine since June 8, 1910, their residence at 75 Indian Grove, Toronto, being enlivened by the presence of two sons.

Well on the right side of forty, Mr. Evans takes a keen interest in the rising generation. A strong admirer and advocate of all Y.M.C.A. activities; a keen participant in out-of-door sports; an ardent motorist; an out-and-out square dealer with everyone, Mr. Evans is, in addition, particularly qualified to appreciate the requirements of the future workers in engineering circles. "The duties of employers toward their youthful employees only begin with the pay-

ment of wages. The future of each one of them will be largely influenced by the treatment meted out by his first employer. Knowledge must be acquired rapidly and permanently if future promise is to be fulfilled. Assisting apprentices to obtain ample and up-to-date equipment of tools is one way in which firms may secure faithful and lasting service, but present and future developments render technical study almost more important. The modern technical journal is a vade mecum for all progressive spirits, whether in sales force or shop, and as an exchange medium for ideas, possesses a value which must sooner or later be more fully recognized by employers and employees. The sooner the better."



SCREW-CUTTING IN ALUMINUM

THE cutting of perfectly clean threads in aluminum, either by machinery or by hand-power, is a problem which has tried the patience of many an engineer. In a screw-cutting or a tapping machine, the metal tears away, notwithstanding the lubricant hitherto used, and a large proportion of the threads are destroyed in the process, or are imperfect. When cutting the threads by hand power—a kind of hard labor when the lubricant used is unsatisfactory—the same defects generally occur, or when they do not, the threads are not clean and uniform throughout, for the point at which the man stopped to give another fraction of a turn to the screw or die-stock is marked by dents and raised portions on a series of the threads and over the whole threaded depth. Such difficulties, however, generally give way in time to patient experimenting, and in this case they appear to have done so, for quite recently we had the opportunity of seeing inside taper-threads cut with cleanliness and accuracy by the aid of a new lubricant. The job in hand was an order for aluminum adaptors for shells, and naturally ran into very large numbers. Under the old conditions it was slow and not satisfactory, but with the new lubricant the adaptors were turned out at the rate of sixty to seventy per hour by two boys. The lubricant also increases the life of the screw-taps, one pair we saw having cut as many as 7,000 aluminum adaptors. This lubricant is also of great value for other processes in the manufacture of aluminum articles, especially turning and machining, a great increase in output being obtained.



CANADIAN PULP AND PAPER

THE progress that Canada is making toward becoming the world's centre for the manufacture of pulp and paper is indicated in figures recently published by the Department of Trade and Commerce. For the year ended July, 1916, the exports of paper amounted to \$21,678,868, of which 88 per cent. went to the United States and 5.2 per cent. to the United Kingdom. This total is an increase of 31 per cent. over the figures for the year

previous. The rate at which this business has grown in Canada will be appreciated when it is realized that the first export shipment of paper from Canada was made in 1892, amounting to a total of \$91 for that year. The total exports for 1902 were but \$24,000, and for 1913 only \$6,327,000.

Taking the situation as a whole the total exports of paper, pulp, and pulpwood for the fiscal year ended July, 1916, were \$40,865,266, of which the United States received 87 per cent. and the United Kingdom 5 per cent. The increase over the previous year was 27 per cent. On the other hand, Canada imported, during the year ended July, 1916, \$6,327,298 worth of paper and manufactures of paper.

The foregoing facts, in conjunction with the use by Canadian pulp and paper mills of nearly \$9,500,000 worth of pulpwood, indicate the tremendous drain upon our pulpwood resources, according to a statement issued by the Conservation Commission. This drain is likely to increase rather than diminish in view of the rapid depletion of accessible supplies of timber, suitable for pulpwood in the United States. If this great source of national wealth is to be perpetuated, much more stringent measures than in the past must be taken to prevent destruction by fire and to ensure the restocking of valuable species of cut-over and burned-over areas.



Silvering Brass for Lacquering.—It often happens, in finishing ornamental work, that silver bands or reliefs are needed, the thickness of the silver, of course, being a minimum. To make a good and efficient solution for the purpose, dissolve 1 oz. of good nitrate of silver in a quart of distilled water, and in a separate vessel make a semi-saturated solution of hyposulphite of soda. Add sufficient of the hyposulphite solution to the nitrate of silver solution to throw down the silver as a brownish precipitate, agitating the liquid; then add, drop by drop, sufficient of the hyposulphite to re-dissolve the precipitate, and after this is secured add a slight excess of hyposulphite. Store in black or other non-actinic glass bottles, well corked. To use, apply to the clean metal with a sponge or brush, and rinse off with clean water, and dry thoroughly before lacquering.



Harmony in organisation is something that will make success against many adverse conditions, and the lack of it will generally ensure defeat, regardless of all other conditions. The thoughtful work of each man is the real progressive work, and although this is stimulated by a wholesome rivalry, it is wholly checked by strife.

Life is simply a matter of concentration. You are what you set out to be. The things you read and think to-day are the things you become to-morrow.

STEEL PLANT EXTENSIONS IN 1916.

FROM statistics compiled by a U.S. contemporary covering steel plant improvement and extension, during last year, the following data pertaining to Canadian establishments is available:

The Algoma Steel Corporation, Sault Ste. Marie, Ont., added a 32-in. billet mill. In the duplex plant, two 75-ton stationary open-hearth furnaces were also built. This year a 75-ton stationary open-hearth furnace will be constructed and also a heavy structural mill.

The Dominion Iron & Steel Co., Sydney, N.S., has under construction a new 400-ton blast furnace. Contracts have been awarded for 120 Koppers by-product coke ovens with a capacity of 11.2 tons of coke each in 24 hours.

The Steel Company of Canada, Hamilton, Ont., completed and put in operation three 75-ton open-hearth furnaces and doubled its soaking pit capacity. It also made large additions to its shell-forging plant. At its Montreal plant a large addition was made to the shell-forging plant. A new 75-ton open-hearth furnace is under construction.

The Canadian Car & Foundry Co., Montreal, Canada, made such additions to construction and equipment as were necessary for the furtherance of munition work, but the company does not consider this as capital expenditure. Over \$1,000,000 has been spent or authorized on this line of work, although it is not considered as of a permanent character.

The Canadian Car & Foundries, Montreal, built at its Welland, Ont plant two new 25-ton basic open-hearth furnaces, making a total of four, and is now building two more to be completed next month. It has also installed a 1,000,000-gallon oil storage tank and built a new forge shop for forging 5000-4½-in. shells per day. At the company's Longue Pointe works, Montreal, one 25-ton acid open-hearth furnace was built, making a total of four. Another furnace of the same type is under construction to be completed this year. At the Point St. Charles plant, Montreal, one more furnace is contemplated. The company is installing there a forge shop for making 6-in. shell forgings at the rate of 4000 per day, commencing March 1.

The Nova Scotia Steel & Coal Co., New Glasgow, N.S., is erecting a new blast furnace Sydney Mines, N.S.

The Manitoba Steel Foundries, Winnipeg, Man., has practically completed its new foundry. It will make electric steel both in the form of castings and ingots for rolling and will have a capacity of 8000 to 10,000 tons per year.

The Pacific Steel Products, Ltd., Bridgeport, B.C., is constructing a new open-hearth steel furnace and installing machines for turning out railroad spikes, bolts and nuts.

TWIN MUFFLE FURNACE FOR HARDENING HIGH SPEED STEEL.

ONE result of the advent of munitions manufacture has been a very complete realization of the value of high speed steel not only economically when performing its duties as a manufacturing accessory material, but also intrinsically when values are increased and wastage prevails through defective treatment and careless usage.

It is an actual fact that the shortage of this material which was threatened some time ago was in part due to carelessness and lack of facilities for proper hardening and in the course of events it was but natural that the onus of the situation would gravitate towards the makers as the source of the material. As the leading makers of high speed steel in this country, Armstrong Whitworth, Ltd., Montreal, were in a unique position to appreciate the factors of the situation, the result being that they have developed, and are now marketing a hardening furnace for high speed steel which enables the full benefits of this material to be obtained by the average user.

The furnace is of the twin muffle type and oil-fired, the appearance and construction being clearly indicated in the accompanying illustrations. Fig. 1 is a front view, the two chambers being of solid fire brick construction, built into an angle iron frame work, the whole being carried on a braced frame of the same material. The internal design is shown in Fig. 2. An opening A is provided at the back of each chamber, through which the oil and air mixture

enters, the flame impinging on the curved surface of baffle brick B whence it proceeds around each side of the chamber and underneath the hearth C, finally

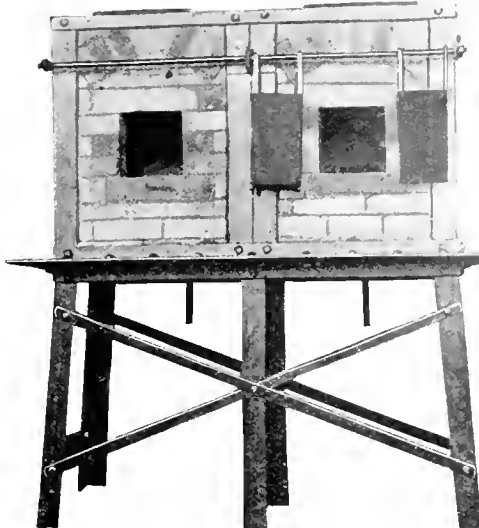

FIG. 1.—FRONT VIEW OF TWIN MUFFLE FURNACE FOR HARDENING HIGH-SPEED STEEL.

ascending past the semi-muffle walls D to the rectangular exit in the arched roof. This arrangement prevents the products of combustion from coming in contact with the work and insures a very even degree of heat throughout the chamber.

The twin chamber arrangement provides ideal conditions for the hardening of high speed steel. The left hand chamber is used for preheating purposes only, the steel being slowly and evenly heated to about 1400 deg. F. when it is transferred to the right hand chamber which heats it quickly to 2200 deg. F., or over if necessary, to be followed by such quenching as is required by the material.

Individual control is provided for each chamber, and low pressures are employed, the air being at 2 lbs. per sq. in. and the oil at

10 lbs. per sq. in., so that gravity feed can be used in the majority of installations.



CONTROLLED ESTABLISHMENTS AND SECRECY

THE British Minister of Munitions appeals to the owners of controlled establishments, to all persons responsible for the management of such establishments, and to the public generally, to guard against communicating to neutral countries information concerning controlled establishments, the effects of control on the conduct of their business, and the character and quality of munitions work in hand. Such information is sometimes conveyed (probably by inadvertence) in replies to inquiries as to whether particular establishments are able to undertake particular classes of work, and also in advertisements in newspapers which circulate abroad. The public are warned that no communications of any kind can be transmitted abroad if they give any indication that a firm is controlled or is engaged in munitions work, or if they contain information with respect to the manufacture, output, or supply of munitions, or with respect to the place where such work is carried on.



DON'T try to remove dirt or cuttings from the small bore of a revolving piece of work, with the fingers. It is a serious thing to have a finger twisted off.

DON'T force a chuck or face plate on a threaded spindle when you find there is dirt in the screw. It may happen that the thread will seize, and cause considerable trouble to remove.

DON'T allow the sleeve of the shirt or jacket to come in contact with revolving lathe work or shafting. Even the smoothest of shafts will take hold of clothing, often resulting in serious mishap.

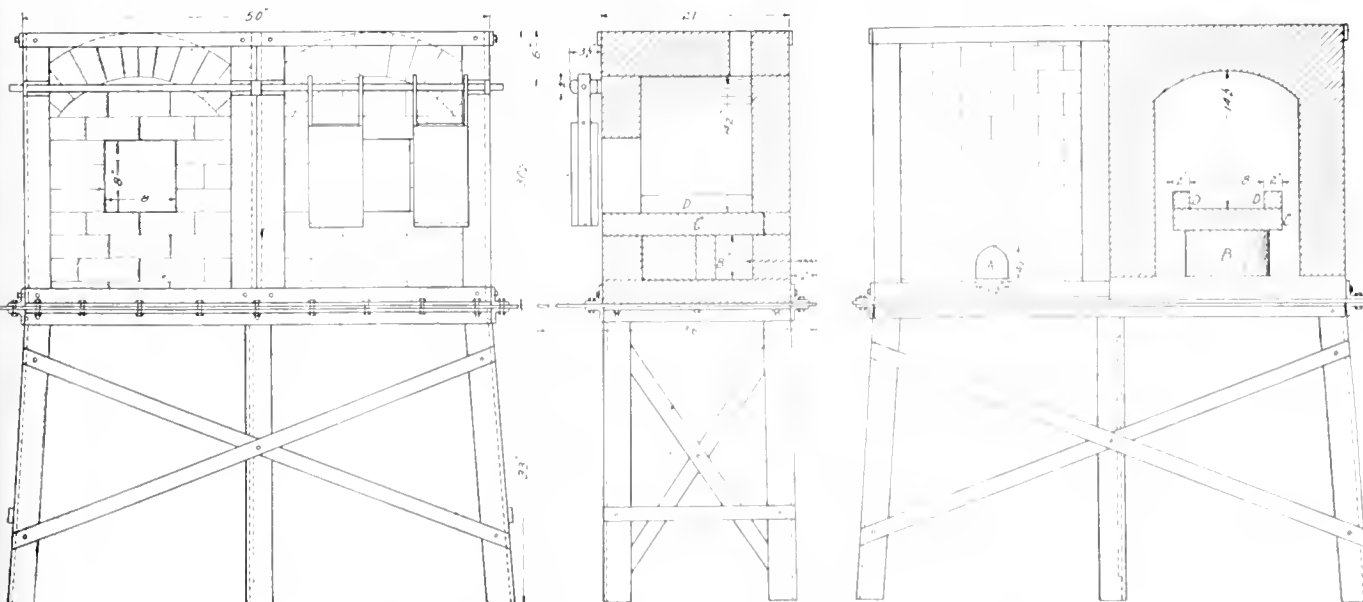
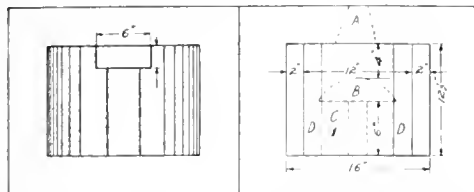

FIG. 2.—DETAILS OF CONSTRUCTION OF TWIN MUFFLE FURNACE.

PROGRESS IN NEW EQUIPMENT

A Record of New and Improved Machinery and Accessories for the Machine, Pattern, Boiler and Blacksmith Shops, Planing Mill, Foundry and Power Plant

DUPLEX SHELL LATHE

WITH the primary object of speeding up production, the Dominion Machinery Co., Toronto, have developed a duplex lathe, in which two shells can be rough turned at one time and by one operator. The lathe, however, is so designed that the shells can be machined individually or together. This is one of the principal features of the lathe, and it is accomplished by means of two separate steel jaw clutches on the main spindle located on either side of the centre driving head. Briefly, it is a modification of an axle lathe adapted for producing shells.

The lathe is of substantial construction, and for this reason is particularly suitable for shell rough turning operations. It will take shells ranging from 4.5 in. to 6 in., and tests have shown 120 4.5 in. shells can be rough turned in ten hours by one operator. The lathe is built for belt or motor drive, and the clutches obviate the necessity of stopping the machine when chucking. The main spindle is mounted in heavy bronze bearings, and is driven in the centre through triple gears with a ratio of ten to one. At each end of the main spindle is fitted a steel jaw clutch. The driving section of each of which has a square recess for receiving and revolving the chuck. The chucks used on this lathe are of special expanding roller type, and are independent of the lathe. The chuck is placed inside the shell, which is placed between the lathe centres. The chuck fits in the square recess on the clutch,

When the clutch is thrown-in, the shell revolves and the feed is started. The same operation is then performed on the other side of the lathe.

Both carriages are driven independently with positive worm drive, they are also fitted with hand feed. An automatic trip is provided for the carriages which stops the feed at the end of the cut. A considerable saving in floor space has been effected in relation to the output, and the lathe has been designed with all parts in excess of the most exacting requirements. The lathe in working order weighs approximately 8,000 pounds.

SENSITIVE MULTIPLE SPINDLE DRILLING MACHINE

THE accompanying illustration shows a regular type of small, sensitive, multiple spindle drill which has been designed for light drilling, countersinking, etc. The table is cast separate from the base when required.

Either 9 in. or 12 in. round heads can be furnished, the former being equipped with from 2 to 10 spindles of 1 in. dia., and the latter with from 2 to 16 spindles of $\frac{3}{4}$ in. dia. A six-armed pilot wheel, keyed to rack pinion shaft gives sufficient leverage for easy drilling, the rack pinion being heat treated and keyed to pinion shaft. All pinions are of .30 carbon steel with double bearings integral with pinions, and running in oil. Roller bearings are used in the idler pulleys and the drive pulley on the vertical

type composed of three parts only, two forks milled from the solid and a centre block of similar construction, dispensing entirely with pins, serews or rivets. These parts are hardened.

Crucible steel spindles are employed

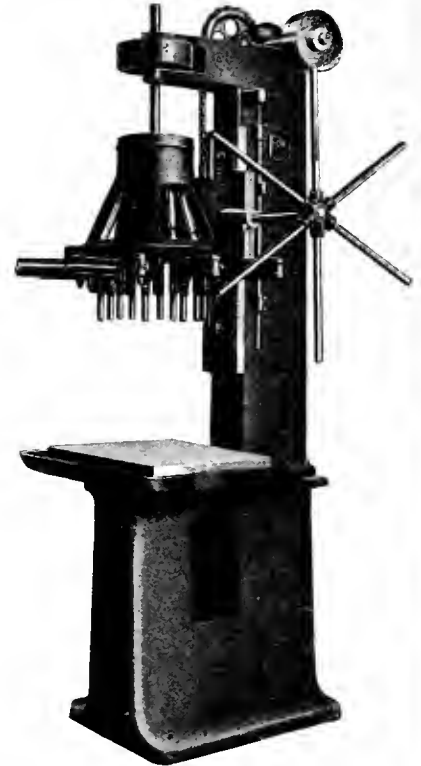

SENSITIVE MULTIPLE SPINDLE DRILLING MACHINE.

a new type of adjusting arm permitting rapid adjustment and rigid support. Special cluster plates are supplied when required by the makers, the Fox Machine Co., Jackson, Mich.

SCRAP RECLAIMING PRESS

THE development of the Southwark Gross press marks an important step toward the solution of many railroad shop problems connected with the reclamation of scrap material from wrecked cars and general repair work, the rapid and almost universal adoption of all-steel equipment having rendered largely inadequate the former press equipment which was only adapted to the needs of wooden cars.

Its usefulness, however, is not limited to railroad needs, as the necessity for a press of this type has been constantly growing in many branches of iron and

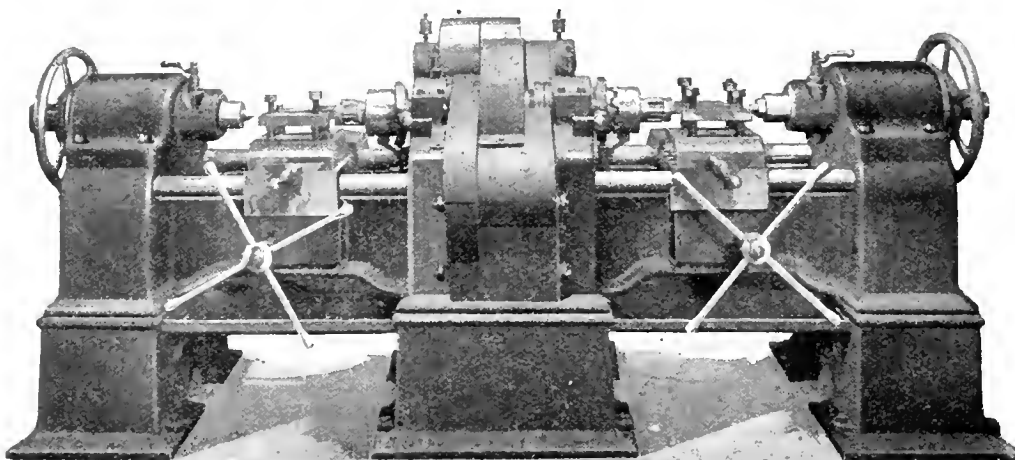

DUPLEX SHELL LATHE FOR ROUGH TURNING OPERATION

and the base of shell, being countersunk, is carried on the tailstock centre. The chuck is so constructed that the deeper the cut the tighter the shell is held on it.

shaft runs in bronze bushed bearings; ball bearings are provided for end thrusts.

The universal joints are of a patented

steel industry, the accompanying cuts serving to convey some idea of its adaptability to the needs of general manufacturing and repair work.

The base of the Southwark Cross is a heavy steel casting with a flat surface which forms the foundation for the structural steel frame, consisting of two steel uprights which support a main cross frame. The top of this framework is braced by heavy tie rods attached to the four corners of the base platen.

The pressure cylinder is suspended from the cross frame by means of a four-wheel carriage, while the travel of the ram is controlled by means of a specially balanced type of four-way valve located in a position convenient to the operator; the carriage is propelled backward and forward across the top frame by an endless chain traveling over sprockets.

The guide for the piston rod is held between two angle irons fastened to the vertical columns. The piston of the pressure cylinder is 20 inches in diameter and has a stroke of 36 inches. It is packed with leather cup packing which can be quickly renewed when necessary. The end of the piston rod is fitted with a die which can be changed in a manner similar to the die of a steam hammer. Air is supplied to the double-acting cylinder by flexible hose connections so arranged and sufficiently long to permit free movement of the cylinder as it travels across the table.

Dies of great variety can be used and new dies made at any time to meet special requirements. While in most instances the work requiring bending or straightening can be handled cold, in some few cases with extra heavy parts it may be necessary and safer to heat the work before subjecting it to a pres-

sure of fifteen tons which is the capacity of this press. Bending parts of this description while cold is likely to result in cracking. However, with the modern means of welding, such as the oxyacetylene torch and other processes, these cracks are not serious and may

The heavily ribbed headstock has an unusually long bearing on the lathe bed and has a 6½ in. x 10 in. front bearing for the spindle, with 4½ in. x 7 in. at the rear. It is of the all geared design with single pulley drive, giving 12 spindle speeds from 8 to 300 revs. per

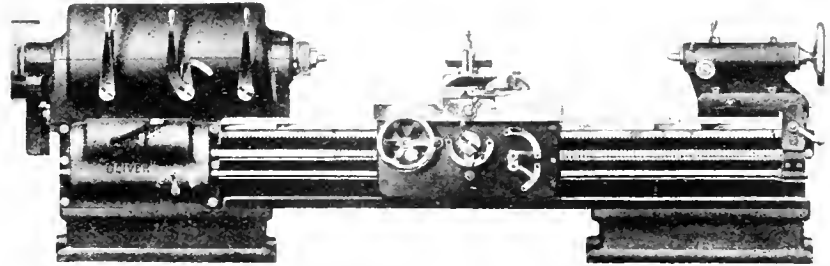

EXTRA HEAVY DUTY 26" ENGINE LATHE

be more quickly remedied and defective parts made sound at less cost than they could be either straightened or reclaimed by the obsolete processes formerly in use.

The builders of this press are the Southwark Foundry & Machine Co., Philadelphia, Pa.



EXTRA HEAVY DUTY 26 in. ENGINE LATHE

PROPER distribution of weight and correct proportioning of mechanism are features which have received particular attention in the 26 in. engine lathe illustrated herewith. It is intended to meet satisfactorily all the demands of extra heavy duty resulting from the use of the most efficient tool steels.

min. The spindle is lubricated by large oil chambers feeding through felt wipers, while a hole large enough to pass a 3 in. bar is provided. High carbon steel is used for the spindle which runs in two piece replaceable bronze bearings adjustable for wear. Large diameter cast steel gears are entirely enclosed, and run in oil, all pinions being of forged steel.

The tailstock spindle is 4 in. dia. and is locked by clamps acting on two sides, while 4 large clamp screws with hardened nuts secure the tailstock firmly in place. A geared crank is provided for moving the headstock along the bed. Both spindles are fitted with No. 6 Morse taper centres.

The bed is of refined box type design with liberal support from box column

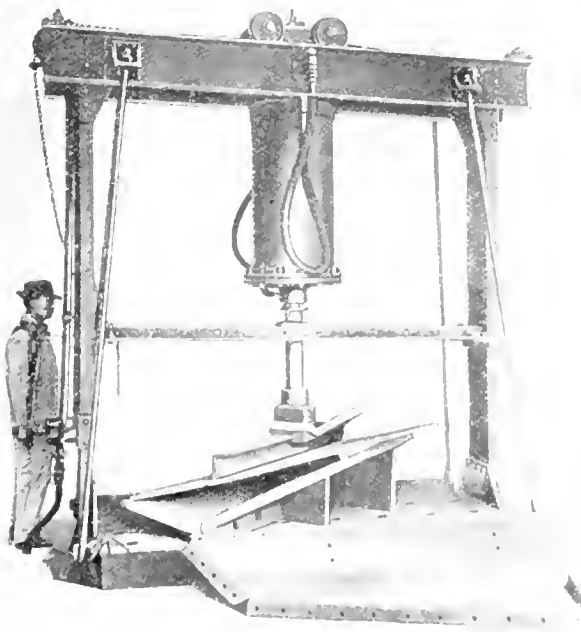

RECLAIMING PRESS FORMING HOPPER SHEETS FOR STEEL CARS.

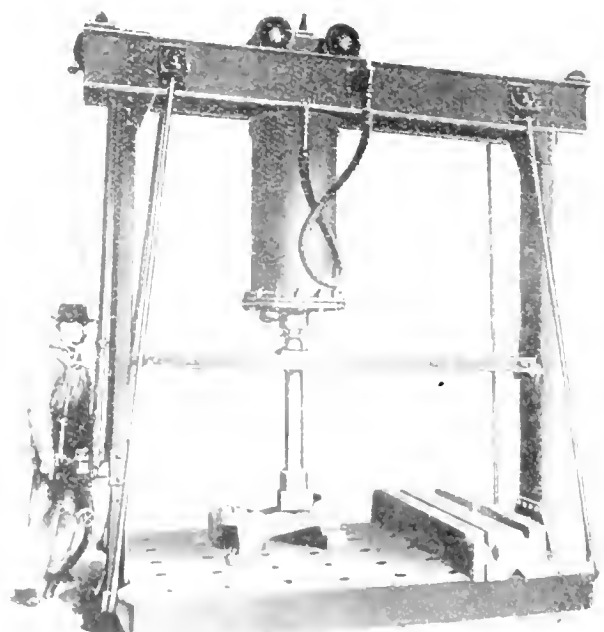

STRAIGHTENING BENT DRAW HEADS IN RECLAIMING PRESS.

pedestals without any overhang. The width across shears is $24\frac{3}{4}$ in. braced by closely spaced box sections, the width and depth of the bed being sufficient to prevent spring under the heaviest cuts.

The carriage has an over all length of 40 in. with a 12 in. bridge. Taper gib adjustment is provided both on cross slide and compound slide, these and the carriage being scraped to perfect bearings on their respective parts. The compound slide is presented at an angle of 30 degrees, providing a more solid bearing capable of easier manipulation. Felt oil wipers on shears, micrometer dials, chip guard and thread dials are evidence of the completeness of detail.

The double plate box type of apron provides bearings at each end of the feed gear shafts, the front removable plate permitting access to the mechanism without removing the apron from the carriage. The friction drive on both longitudinal and cross feeds is controlled by a single lever so that both feeds cannot be thrown in at the same time, while none of the feed mechanism can be put into gear when the lead screw is in operation.

The $2\frac{1}{4}$ in. lead screw has 2 threads per in. and engages with two bronze half nuts. Thirty-three threads ranging from 1 to 16, and a similar number of feeds from .013 in. to .333 in. per revolution of spindle are obtained through the gear box, which is fitted with steel gears and bronze bushed bearings, the gears being changeable while running.

A double friction type countershaft is usually furnished, and the headstock is designed to readily accommodate a driving motor. The regular equipment includes one steady rest, one 26 in. face plate, one 12 in. face plate, with centres, wrenches, cranks and countershaft. Extra equipment includes fittings for motor drive, taper attachment, follow rest, square tool post, hexagon turret, and self-contained gib crane. Weight crated, 12,600 lbs.

The builders of this lathe are the Oliver Machinery Co., Grand Rapids.

SCREW MACHINE EQUIPMENT

CONSIDERABLE changes have been effected recently in the No. 5 screw machine built by the Foster Machine Co., Elkhart, Ind., calculated to increase the ability and scope of the machine to a marked degree. Two styles of this machine are now offered, one with back-gear cone head, and the other with an all geared head, the latter being shown in Fig. 1 complete with new bar equipment.

In order that the efficiency and productive capacity of this machine can be utilized to the maximum extent, the makers have designed a very complete line of tools, so that not only can the production, on what is commonly regarded as screw machine work in its narrow sense, be increased to a considerable extent, but the general range of work which can be handled to advantage is greatly increased, and in-

cludes practically all kinds of chucking work within the capacity of the machine.

One of the outstanding tools for bar work is the roughing box tool or single cutter turner, of which a new design has been gotten out for this machine. The cutter is located radially to the work, so that it is ground on the end when being sharpened, economizing tool steel. Back rests of the roller type, with hardened and ground rolls and roll studs, are mounted on independent slides which are adjustable by means of a graduated screw. The cutter slide is equipped with a release to prevent marring the work when withdrawing, the release being operated by a lever handle in front of the tool, which also binds the cutter slide rigidly to the tool body, a graduated dial being provided for setting the slide operating screw. A multiple cutter turner, a pointing tool and a new design of adjustable hollow mill are further items in the bar stock group. The hollow mill is shown at right, Fig. 2, and is specially designed for rapidly removing a large amount of stock on comparatively short work, having the desirable feature of being easily adjustable for different diameters. The multiple cutter turner is a tool for turning more than one diameter at the same setting. Back rests similar to the single cutter turner are used, while the cutters are held in supports so that they may also be shifted to and secured in any desired position on the body casting. When desired, this tool can be equipped with three double tool holders for taking up to six cuts simultaneously, shoulders only $\frac{1}{4}$ in. apart being formed with it.

In connection with chucking work, an interesting tool is shown at left, Fig. 2, this being particularly well adapted for recessing and back facing, also for boring work in small quantities. The tool is carried in a quadrant shaped member hinged on the front of the main casting, the pivot on which it swings being located below the cutter. It is operated by the handle shown, two stop screws being provided for adjustment and stop purposes at each limit of travel.

The variety of equipment is well rounded out by a large selection of miscellaneous tool holders and adapters, cut-off slides, drill, tap and die holders,

FLAG DAY INCIDENT

IT was "Flag Day." Beauteous vendors pressed their wares at every street corner and lurked in every doorway. Jones

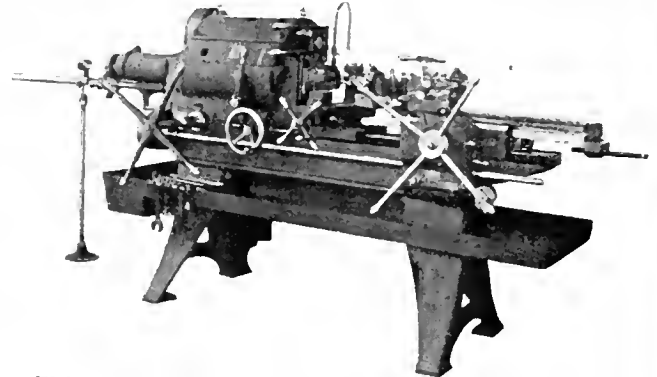

FIG. 1. GEARED HEAD SCREW MACHINE WITH TOOL EQUIPMENT FOR BAR WORK

threaded his way through the city streets and arrived at the offices of that old Scotch firm, Duncan, M'Haggis and Fraser.

Mr. Duncan, he was told, was out, but the other two partners were in, and he was presently ushered into an inner sanctum, where he found M'Haggis and Fraser sitting on either side of the fire and looking distinctly disconsolate—not to say hungry.

"It's really Duncan I want to see," explained Jones, "but since it's about lunch-time I thought we might all go

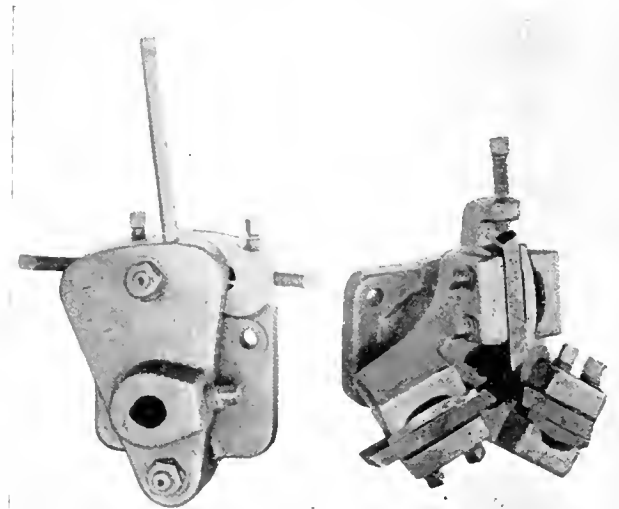

FIG. 2. LEFT, RECESSING TOOL. RIGHT, HOLLOW MILL.

out together, and I'd come back with you and talk to him afterwards."

"I am sorry," said Fraser dourly, "but we canna come out to lunch."

"What—aren't you going to have any?" asked Jones in astonishment.

"Aye, aye—but we must bide a wee—Duncan has the flag."

Affidavit Forms for Importers.—The Trade and Commerce Department, Ottawa is issuing to all Canadian importers a form of affidavit to be made out before shipment of restricted goods from the United Kingdom can be made. The affidavit will contain information such as quantity and description of goods ordered, use to which they will be put, etc.

The MacLean Publishing Company

LIMITED

(ESTABLISHED 1888)

JOHN BAYNE MACLEAN - - - - - President
H. T. HUNTER - - - - - Vice-President
H. V. TYRRELL - - - - - General Manager

PUBLISHERS OF

CANADIAN MACHINERY AND MANUFACTURING NEWS

A weekly newspaper devoted to the machinery and manufacturing interests.

PETER BAIN, M.E., Editor. B. G. NEWTON, Manager.
Associate Editors.
A. G. WEBSTER, J. M. WILSON, J. H. RODGERS.

Office of Publication, 143-153 University Avenue, Toronto, Ont.

Vol. XVII. JANUARY 25, 1917 No 4.

AN EVENTFUL WEEK

THE past week has been in many respects an eventful one, having to its credit and otherwise the issuance of an exposition of idealism in affairs international by the President of the United States; the destruction by fire and explosion of a British munitions factory with attendant serious loss of life; the unfolding of a tale of shipping tragedies through the instrumentality of a German sea raider, and official intimation that the Imperial Munitions Board have determined to erect immediately a mammoth steel plant in our midst for the more intensive production of munitions. It may be said, relative to each of the foregoing, that there is much food for thought, and while the last named appeals to our commercial sense, at least, in manner to excite satisfaction, it cannot be so said of the other happenings. If we add to the list the impressive stride that stocks and particularly war stocks have acquired in the direction of saner and real-value levels, then it must be admitted that this New Year, 1917, is off to a spectacular if ill-assorted start. Concurrent with the break in stock exchange values, it is quite in order that manufactured products, whatever their constituent or purpose, should evidence a like material shrinkage, and we are of opinion that such an eventuality is a near-future possibility, if not immediately imminent.

Practical peace will come before the idealistic, therefore grim work must perforce be yet performed. Idealism at this juncture is synonymous with being seared.



HIS MAJESTY'S CANADIAN TORPEDO BOAT "GRILSE"

IN our December 21 issue, reference was made editorially to the specially trying experience from which His Majesty's Canadian Torpedo Boat "Grilse" and the majority of her crew had just emerged successfully. We have been asked by Lieut. J. K. L. Ross, R.N.C.V.R., former owner and commander of the vessel, and by whom with a commendable patriotism she was handed over to the Canadian Department of Naval Service, to state that the illustration which appeared on page 617 did not represent the "Grilse," also to correct some inaccuracies in the text matter. This we take pleasure in doing by publishing his letter which will be found on page 74 of our present issue.

The writer being familiar with the appearance of the vessel—having seen her "war dressed" on several occa-

sions, has no hesitation in stating that the photograph received from Lieut. Ross, along with his letter, is more truly representative of the "Grilse" than that published previously by us. We, however, to avoid a possible clash with the Censor, did not positively identify the craft, the underline to the illustration having the qualification—"Speed Pleasure Yacht." Further, and to quote direct from our previous editorial, it was stated that—"to those unfamiliar with the appearance of the vessel, a very good idea is to be had from our illustration." Referring to Lieut. Ross' letter, and the survey report on the vessel, we may state that the name of the gentleman who furnished the latter has been given us. He is personally known to the writer and is well qualified to pronounce authoritatively on such craft as the "Grilse" and on war vessels generally, as well.

We are further advised by Lieut. Ross that during his twelve months' command of the "Grilse," "they were out in all weathers, and on one occasion I took her through a cyclonic storm near Bermuda, it being necessary then to keep to sea for nearly a full week. Nobody was hurt aboard and not a rivet was started. It was uncomfortable," he states, "as all destroyers are, but I always felt confident that the 'Grilse' would weather any storm if navigated carefully." The vessel is over 200 feet long, not 175 feet. She was built by Yarrow's Ltd., and not by Thornycroft. Regarding her builders, for record purposes, the information is desirable; as indicative of high quality product, however, no distinction may be drawn between the two builders named, our views in this respect being clearly evident from the opening sentence of our previous editorial which we here quote: "The fact that H.M.C. torpedo boat 'Grilse' managed to make port after being battered and bruised to the point of foundering with all aboard is due in the first place to her soundness of construction at the hands of her builders, and secondly to the herculean efforts of the crew to keep her afloat by hand pumping and baling, even when all hope of rescue seems to have faded."

Readers of our journal will appreciate Lieut. Ross' desire to put before them the facts bearing on the "Grilse" construction, transfer, and his own service as her commander, and will concur with us in the opinion that, so far as he is concerned, neither effort nor expense were spared in the performance of his patriotic act. We still think, however, that poor judgment was displayed by those in authority in putting the "Grilse" to sea—especially on the North Atlantic in mid-winter, and while we do not hesitate to stand alone in so expressing ourselves, we are pleased to state that we have the unqualified support of perhaps the most prominent authority on light craft construction and exponent of their navigation on this continent.

We should have been pleased to publish the photograph of the "Grilse" in her "war dress," but the Censor is unrelenting. Lieut. Ross fully appreciates the situation in this respect, as will also our readers.



BALKING "SAFETY FIRST"

APROPOS of the snuffing-out of a useful life, the more or less serious injury received, and narrow escape with life and limb, by a goodly number of others, on the occasion of the departure of a troop train from the Union Station, Toronto, on the night of January 21, it seems opportune to point out to our railroad managers as well as to our military authorities the necessity of their rebutting the all too prevalent tendency of civic administrators to "butt-in" and largely set aside an otherwise well ordered and successfully applied "Safety First" propaganda.

BOILER TUBES.		TAPES.		ANODES.		ft.	
Size.	Seamless	Lap-welded	Chesterman Metallic, 50 ft.	\$2 00	Nickel50 to .54
1 in.	\$30 00	Lufkin Metallic, 603, 50 ft.	2 00	Cobalt	1.75 to 2.00
1 1/4 in.	30 00	Admiral Steel Tape, 50 ft.	2 75	Copper44 to .46
1 1/2 in.	30 00	24 00	Admiral Steel Tape, 100 ft.	4 45	Tin49 to .56
1 3/4 in.	29 00	21 00	Major Jun. Steel Tape, 50 ft.	3 50	Zinc23 to .25
2 in.	33 00	20 00	Rival Steel Tape, 50 ft.	2 75	Prices Per Lb.		
2 1/4 in.	33 00	Rival Steel Tape, 100 ft.	4 45	COPPER SHEETS.		
2 1/2 in.	35 75	26 50	Reliable Jun. Steel Tape, 50 ft.	3 50	Montreal Toronto		
3 in.	55 00	31 00	WASTE.		Bars, 1/2 to 2 in.		
3 1/4 in.	54 50	36 00	White Cents per lb.		Plain sheets, 14 oz.,		
3 1/2 in.	59 50	39 00	XXX Extra	20	14x28 in., 14x60 m		
4 in.	75 00	49 00	Peerless	20	45 00 45 00		
Prices per 100 feet, Montreal and Toronto.			Grand	19	Copper sheet, plain-		
OILS AND COMPOUNDS.			Superior	19	ished, 14x60 base,		
Castor oil, per lb.	25		X L C R	18	57 00 57 00		
Royalite, per gal., bulk	12		Atlas	18	Braziers' in sheets,		
Machine oil, per gal.	25 1/2		X Empire	18	6x4 base		
Black oil, per gal.	12 1/2		Ideal	17	46 50 46 50		
Cylinder oil, Capital	45 1/2		X press	16	BRASS.		
Cylinder oil, Acme	36 1/2		COLORED.		Brass rods base 1/2 in to 1		
Standard cutting compound,	0.6		Lion	14 1/2	in rd. 0 55		
per lb.	0.6		Standard	13	Brass sheets, 8 in. wide, 20		
Lard oil, per gal.	1 45		No. 1	13	oz. 0 60		
Union thread cutting oil	68		Popular	11 1/2	Brass tubing, seamless... 0 55		
antiseptic	68		Keen	10 1/2	Copper tubing, seamless... 0 55		
Acme cutting oil, antiseptic	37 1/2		WOOL PACKING.		PLATING SUPPLIES.		
Imperial quenching oil	39 1/2		Arrow	25	Polishing wheels, felt.		
Petroleum fuel oil	10 8 1/2		Axle	30	Polishing wheels, bull-		
BELTING—NO. 1 OAK TANNED.			Anvil	15	neck 1 35		
Extra heavy, single and	30-5 1/2		Anchor	11	Emery in kegs, Ameri-		
double	40%		WASHED WIPERS.		can 06		
Standard	40%		Select White	12	Pumice, ground 01		
Cut leather lining, No. 1.	\$1 50		Mixed colored	10	Emery glue 15 to 20		
Leather in sides	1 30		Dark colored	09	Tripoli composition... 01 to 06		
			This list subject to trade discount for quantity.		Crocus composition... 07 to 08		
			RUBBER BELTING.		Emery composition... 08 to 09		
			Standard	50%	Rouge, silver 35 to 50		
			Best grades	50%	Rouge, powder 30 to 35		
					Prices Per Lb.		
					LEAD SHEETS.		
					Montreal Toronto		
					Sheets, 3 lbs. sq. ft. \$12 00 \$12 50		
					Sheets, 3 1/2 lbs. sq.		
					Prices Per Lb. Unless Otherwise Stated.		
					Acid, boracic \$ 15		
					Acid, hydrochloric05		
					Acid, hydrofluoric 14 1/2		
					Acid, nitric 10		
					Acid, sulphuric05		
					Ammonia, aqua08		
					Ammonium carbonate 15		
					Ammonium chloride 11		
					Ammonium hydr sulphuret 40		
					Ammonium sulphate97		
					Arsenic, white12		
					Copper, carbonate, anhyd. 25		
					Copper, sulphate17		
					Cobalt sulphate70		
					Iron perchloride20		
					Lead acetate16		
					Nickel ammonium sul-		
					phate12		
					Nickel carbonate25		
					Nickel sulphate15		
					Potassium carbonate75		
					Potassium sulphide (sub-		
					stituted)20		
					Silver chloride (per oz.)05		
					Silver nitrate (per oz.)25		
					Sodium bisulphite10		
					Sodium carbonate crystals05		
					Sodium cyanide, 127-130% 11		
					Sodium hydrate04		
					Sodium hyposulphite, per		
					100 lbs. 5 00		
					Sodium phosphate 14		
					Tin chloride00		
					Zinc chloride20		
					Zinc sulphate09		

The General Market Conditions and Tendencies

This section sets forth the views and observations of men qualified to judge the outlook and with whom we are in close touch through provincial correspondents

Montreal, Que., Jan. 22, 1917.—Industrial interests are again resuming the activity that was recently disturbed by international developments. The attitude of Britain however, has added confidence to the situation. Freight congestion has been somewhat relieved but is as yet not all that might be desired. Severe storms are adding to railroad troubles and delivery of material is very indefinite.

Fig Iron

The general market is unchanged, the quotations having undergone no advance during the week; railroad troubles are effecting transportation and some furnaces are operating light.

Steel

The production of steel at the present time is being greatly curtailed through the difficulty of seeing the required raw material with which to carry on operations. The scarcity of coke has resulted in the temporary banking of several furnaces, and transportation troubles add to the discomfort of steel producers. The relief that was offered last week through the decline in coke has again reacted and coke is now selling at \$10, an advance of \$1 per ton. More active inquiries are in the market and the general situation has re-

covered from the scare that loomed up some few weeks ago over the possibility of peace negotiations. The demand for billets and steel bars is as insistent as ever and the supply is not sufficient to meet the trade requirements. The construction of many factories and buildings maintains a good demand for structural material. The unsatisfied demand for steel plates by ship and car builders may shortly result in further advances on these lines. Inquiries for sheets are not so heavy but the relief is acceptable to the mills under their filled up condition. Local prices have nominally advanced on black sheets and Premier galvanized; 1 1/2c per pound on the former and one cent on the latter. The situation in wire and wire products has been without feature for some time and some mills are feeling about for additional business. It is the general impression that present prices will be maintained for some time. The demand for wire rods however is in excess of the supply and higher prices are not improbable. Wrought iron pipe and boiler tubes are in good demand; many makers of the latter being hiked up for from 12 to 18 months ahead. Nominal prices are all that are listed and further advances to these may be expected. Weather conditions and freight embargoes are seriously effecting production

and shipping facilities in every direction.

Metals

The general market is featured by a gradual return to more settled conditions, following the firm attitude of Britain in her reply to recent "peace" manoeuvres. Copper has regained some of its recent loss. Tin is stronger as a result of increase marine risks. Spelter is quiet but firm. Lead is scarce and more active.

Copper.—A firmer tone has at last been attained and the strength of the market is reflected in higher prices. This has resulted from the unflinching attitude of the British Government. The return to higher prices however, is not the result of an active increase in the demand, but owing to the fact that producers are not over anxious to quote or offer metal for sale. This stand has caused holders of resale metal to secure offers at higher prices. Following the progress of events of the past several weeks, it is rumored that negotiations are contemplated for future requirements for the Allied governments, and in anticipation of present conditions continuing the situation will undoubtedly regain much of the strength lost during the recent unsettled period. With the British situation under the control of the authorities, the market at present remains quiet, but the New York situation has steadied under the firm tone and nominal price is now 2c higher than last week; lake being back to a basis of 30c and electrolytic 31c per lb. In spite of the unsettled market conditions that have featured the metal situation, local dealers have retained their high

quotations and present developments would seem to indicate their faith in the market. Lake and electrolytic are steady at 36c and castings at 35c per lb.

Tin.—In the absence of any heavy buying, the market has apparently developed a firmer tone, with advance in price quotations. The cause of this is largely due to the activity recently shown by German raiders on ocean commerce and the increased risk contingent with such developments. Consumers are showing their anxiety over the present conditions, and nervousness marks the trend of the market. While the movements of raiders and shipping knowledge remain uncertain, the market is likely to continue to hold firm, and probably show further strength. London and New York are both higher, the latter quoting 45¹/₂c, an advance of 2¹/₂c on the week. Dealers here, while reporting a firmer feeling, are maintaining last week's prices of 47c per lb.

Spelter.—This metal continues very quiet, buying being confined to small job lots. The trade is somewhat at a loss to define the uninterested attitude of consumers, as it is generally conceded that many of these are not well covered for early future requirements. The demand for spelter has been correspondingly lower than for copper, and unless orders are being placed without the knowledge of the trade, it is expected that greater activity will develop within the next few weeks. Quotations have declined on the London market, but New York shows an advance of nearly 1¹/₂c, the current price being 10c per lb. Conditions here are unchanged, with prices firm at 13¹/₂c per lb.

Lead.—The dullness that was apparent last week has been shaken off, and the market has added strength to its recent firmness. This is not alone due to altered political conditions, but also to a visible scarcity of available metal. Consumers, however, are cautious regarding their purchases in view of possible developments. New York quotations are very firm, with independents asking 7³/₄c, an advance of 1¹/₂c over last week. Dealers here continue to quote 10c on a steady market.

Antimony.—The market is quiet, with a firmer undertone, owing to decrease in visible supply. New York is quoting 15c, an advance of ³/₄c on the week. Dealers here are asking 16c, this being 1c higher than last week.

Aluminum.—The market is steady, with weakness showing on New York quotations. Prices here are firm at 70c per lb.

Machine Tools and Supplies

Steady activity continues throughout the machine tool industry, but the present demand is confined to small or single lots for specific purposes. Additions to munitions plants has called for new equipment, but bulky orders are now the exception rather than the rule. A feature of the situation is the increased interest that American machine houses are taking in the Canadian field. This is

due to the probability that munitions contracts are being rapidly completed in the States, with little prospect of further orders. Many firms that have recently made their final shipments are now offering their entire outfit for sale. The supply situation is still very active, and price advances are still the feature of the market.

Scrap

The market in scrap is a little stronger than last week, but is still inactive. A general advance has affected the New York situation. The dealers here report satisfactory transactions, with prices slightly stronger. Coppers are higher, 20c being asked for light and 24c for heavy and crucible. Machine compositions and turnings are ¹/₂c higher, being quoted at 21c and 17c respectively.

Toronto, Ont., Jan. 23.—Further evidence of the importance which is attached to the munitions industry and its development is shown in the decision to establish a steel plant in the Ashbridge's Bay industrial district. This will be distinctly beneficial to Toronto not only under present conditions but also after the war.

The industrial situation is still being affected by transportation difficulties principally by reason of the continued shortage of coal. Although there has been during the past week a heavy movement of coal from Buffalo to Toronto, it has only been sufficient to take care of immediate requirements. The severe weather has added to the difficulties of the situation and a serious shortage of fuel, threatens the city. All classes of freight, particularly less-than-car-lot shipments, are being delayed in transit, causing considerable annoyance to merchants and others.

Steel

An important and interesting development in the steel trade in this district is the steel plant which the Imperial Munitions Board are going to build here. The new plant will add approximately 100,000 tons per annum to this country's steel supply. It is understood that the plant will be operated as a steel foundry and the output will be taken over by the Munitions Board for the duration of the war. This plant is the outcome of the heavy demand for steel for munitions which is steadily increasing in volume and is leaving a comparatively small tonnage for other purposes. As a result of this situation, prices are very firm and continue to have an upward tendency. Prices on iron and steel bars which had been withdrawn, are now higher, iron bars being quoted at 3.90c and steel bars at 4.10c per lb. Cut nails have advanced 50c and are now quoted at \$4.50 per 100 lbs. The new discount on plate washers is 10 per cent, as against 20 per cent, formerly. There is no improvement in the plate situation; the demand in the primary market continues enormously heavy, and it is predicted that prices will go higher. Prices of boiler tubes

are practically nominal and a further advance is likely in the near future.

There is not much change in the situation as regards black sheets. Production continues to be curtailed on account of the shortage of sheet bars and fuel. Prices are still high and further advances are expected. Prices of galvanized sheets continue firm and are unchanged meantime.

Conditions in the steel trade in the U.S. are quieter but prices continue firm, and on some products have advanced. Steel bars are higher, being quoted at 3.25c Pittsburgh, but plates and small shapes are unchanged at 4.50c and 3.25c, respectively. A heavy demand exists for billets and sheet bars, and prices are higher. Bessemer and open-hearth billets, and open-hearth sheet bars, are now being quoted at \$65 a ton Pittsburgh. Transportations difficulties have not improved and the situation is serious.

Pig Iron

The demand for pig iron for making steel has exceeded the capacity of the Canadian furnaces and consequently considerable tonnages of basic iron are being imported from the States. Orders for basic iron have been placed with Chicago and Cleveland furnaces, while 500 tons of Southern foundry iron have also been purchased by Canadian interests for delivery over the last half of this year. Prices on domestic pig irons are still withdrawn, while U.S. prices are unchanged, basic iron at Buffalo furnace being quoted at \$35 per ton.

Scrap

There have been no price changes this week, but the market is firmer and there is a strong undercurrent which will no doubt result in higher quotations. While the embargo on scrap iron and steel is still in force, licenses are being issued for the exportation of steel boring and turnings up to the end of the month, and the question of further extension is under consideration. Much satisfaction is felt in the trade over the installation of electric furnaces at the Ashbridge's Bay industrial district as it is understood that large quantities of steel scrap, particularly turnings and borings will be utilized.

Machine Tools

There is little change to note in the situation. Local dealers report business as being fairly active, the principal demand being for single machines for munitions plants which are being called upon to increase production.

Supplies

Prices continue to advance on a number of lines of machine shop supplies owing to the high price of raw materials. Pure Manila rope has advanced 1¹/₂c and is now quoted at 27c base. As a result of this, higher prices have been announced on transmission rope and drilling cables, these being now quoted at 35c and 30c base respectively. It will be observed that the differential for these lines has been changed from

4c to 5c. Higher prices on cotton and wool waste have been issued ranging from 1½c to 3c per pound according to grade. A further advance—approximately 5 per cent. has been made on globe, angle and cheek valves. Gasoline has advanced 1c and is now quoted at 29½c a gallon.

Metals

The metal markets generally are firmer following the reply of the Allies to the German peace proposals. A general opinion in the trade is that peace is actually further off than was thought at the time the proposals were offered. Prices however are unchanged although there are indications that an upward movement may soon start. It is not likely the movement will be very pronounced, although the shrinkage in prices will be delayed.

Copper.—As the market is controlled by the British Government following an order recently issued by the Minister of Munitions, prices hardly represent the situation. They are however, firmer and an advance is probable. Local quotations are nominal at 30c per pound.

Tin.—Quotations are firm but the market is rather unsettled owing to the increased dangers to marine transportation by submarines and raiders. Local prices are unchanged at 47c per pound.

Spelter.—The market is dull, and consumers continue to show lack of interest. Spelter is unchanged at 13½c per pound.

Lead.—The market is firm with an upward tendency. The Trust continues to ask 7.50c New York, but outside interests are quoting higher. Local price is unchanged at 8½c per pound.

Antimony.—The market is strong due to the reduced supply of antimony, but quotations are unchanged and nominal at 18c per pound.

Aluminum.—The market is easier on poor demand, but quotations are unchanged at 68c per pound.

Solders.—The situation in solders has improved and quotations have advanced 1c per pound. Guaranteed is quoted at 29½c and strictly at 27½c per pound.



H.M.C. TORPEDO BOAT "GRILSE"

The Editor,
Canadian Machinery and Manufacturing
News,

143-153 University Avenue,
Toronto, Canada.

Dear Sir,—In the December 21st number of your publication, I notice an illustration purporting to be "H.M.C. Torpedo Boat 'Grilse,'" together with an editorial called "The 'Grilse' Near Tragedy." As I purchased the "Grilse," and also served as her commander for about a year, I think an explanation from me is in order.

In the first place, the picture you published of the "Grilse" is not the "Grilse." Of course, I can understand that your article might be justified if the "Grilse" were such a type of ship as your picture shows, because I would

Enlarged Canadian Trade Intelligence Service

Under the arrangement made by the Minister of Trade and Commerce with Sir Edward Grey in July, 1913, the Department of Trade and Commerce, Ottawa, is able to present the following list of the more important British Consulates whose officers have been instructed by the Foreign Office to answer inquiries from and give information to Canadians who wish to consult them in reference to trade matters.

BRAZIL—Bahia, British Consul. Rio de Janeiro, British Consul General.	NETHERLANDS—Amsterdam, British Consul.
CHILE — Valparaiso, British Consul General.	PANAMA—Colon, British Consul. Panama, British Vice-Consul.
COLOMBIA — Bogota, British Consul General.	PERU—Lima, British Vice-Consul.
ECUADOR—Quito, British Consul General. Guayaquil, British Consul.	PORTUGAL—Lisbon, British Consul.
EGYPT — Alexandria, British Consul General.	RUSSIA—Moscow, British Consul General. Petrograd, British Consul. Vladivostok, British Consul. Odessa, British Consul.
FRANCE—Havre, British Consul General. Marseilles, British Consul General.	SPAIN—Barcelona, British Consul General. Madrid, British Consul.
INDIA—Calcutta, Director General of Commercial Intelligence.	SWEDEN—Stockholm, British Consul.
ITALY—Genoa, British Consul General. Milan, British Consul.	SWITZERLAND—Geneva, British Consul.
MEXICO—Mexico, British Consul General.	URUGUAY—Monte Video, British Vice-Consul.
	VENEZUELA — Caracas, British Vice-Consul.

Canadian Commercial Intelligence Service

The Department of Trade and Commerce invites correspondence from Canadian exporters or importers upon all trade matters. Canadian Trade Commissioners and Commercial Agents should be kept supplied with catalogues, price lists, discount rates, etc., and the names and addresses of trade representatives by Canadian exporters. Catalogues should state whether prices are at factory point, f.o.b. at port of shipment, or, which is preferable, c.i.f. at foreign port.

CANADIAN TRADE COMMISSIONERS.

ARGENTINE REPUBLIC—H. R. Poussette, Reconquista, No. 46, Buenos Aires. Cable address, Canadian.
AUSTRALIA—D. H. Ross, Stock Exchange Building, Melbourne. Cable address, Canadian.
BRITISH WEST INDIES—E. H. S. Flood, Bridgetown, Barbadoes, agent also for the Bermudas and British Guiana. Cable address, Canadian.
CHINA—J. W. Ross, 13 Nanking Road, Shanghai. Cable address, Cancom.
CUBA—Acting Trade Commissioner, Lonja del Comercio, Apartado 1290, Havana. Cable address, Cantracom.
FRANCE—Phillipe Roy, Commissioner General, 17 and 19 Boulevard des Capucines, Paris. Cable address, Stadacona.
JAPAN—G. B. Johnson, P. O. Box 109, Yokohama. Cable address, Canadian.
HOLLAND—Acting Trade Commissioner, Zuidblaak, 26, Rotterdam. Cable address, Watermill.
RUSSIA—C. F. Just, Canadian Government Commercial Agent, Alexandriyskaya, Ploshch 9, Petrograd. L. D. Wilgress, Canadian Government Commercial Agent, Bukhholza Ulitsa No. 4, Omsk, Siberia.
NEWFOUNDLAND—W. B. Nicholson, Bank of Montreal Building, Water Street, St. John's. Cable address, Canadian.
NEW ZEALAND—W. A. Reddie, Union Buildings, Customs Street, Auckland. Cable address, Canadian.
SOUTH AFRICA—W. J. Egan, Norwich Union Buildings, Cape Town. Cable address, Cantracom.
UNITED KINGDOM—Harrison Watson, 73 Bashghall Street, London, E.C., England. Cable address, Sleighting, London. S. D. Johnston, Sun Building, Care Street, Bristol. Cable address, Canadian. J. E. Ray, Central House, Birmingham. Cable address, Canadian. J. Forsyth Smith, 27-28 Pearl Building, East Parade, Leeds. Cable address, Canadian. P. A. C. Blekerlike, Canada Chambers, 36 Spring Gardens, Manchester. Cable address, Cantracom. J. T. Lithgow, 87 Union Street, Glasgow, Scotland. Cable address, Cantracom.

SPECIAL TRADE COMMISSIONER—LUMBER

H. R. McMillan, visiting Europe, Africa, Australasia and the Orient.

CANADIAN COMMERCIAL AGENTS

AUSTRALIA—B. Millin, Exchange Building, Sydney, N.S.W.
BRITISH WEST INDIES—Edgar Tripp, Port of Spain, Trinidad. Cable address, Canadian. R. H. Curry, Nassau, Bahamas.
NORWAY AND DENMARK—C. P. Sortum, Grubbeleg, No. 4, Ch. Ishland, Norway. Cable address, Sortum.

CANADIAN HIGH COMMISSIONER'S OFFICE

UNITED KINGDOM—W. L. Griffith, Secretary, 17 Vintola Street, London, S.W., England. Cable address, Dominion, London.
--

not consider the photograph you published as a ship that I would care to go to sea on in the Atlantic in the winter months.

After purchasing the "Grilse," and before she was used by the Department of the Naval Service and altered for war purposes into a destroyer, a report was made by a man who had charge of building British destroyers for a great many years, whose report I would like to quote as follows:

"As requested, I have recently carried out a survey of the hull structure of H.M.C.S. "Grilse," and find this vessel similar in scantling to the early thirty-knot destroyers of the British Navy, but the details of the structural design are more in accord with the latest destroyer practice, and give the vessel more strength than in the old thirty-knotters.

"There are no indications that the vessel is in any way strained, or likely to be strained, provided she is navigated with the usual care necessary in all vessels of this class, none of which will, or are expected to, stand hard driving in bad weather."

I herewith enclose a photograph taken of the "Grilse," from which you will see that there is not the slightest similarity between the "Grilse" and the photograph you published, and I may further state that the "Grilse" is over two hundred feet long, not 175 feet, as has been stated, and constructed of the finest high tensile steel, and was not built by Thornycroft, also as has been stated, but by Yarrows, in England.

Yours truly,

(Signed) J. K. L. P. S.



A FUEL OIL INSTALLATION.

by A. F. Meuzies

THE reference to a fuel oil installation in a recent issue of one of your journals, prompts me to give the following description of a mechanical atomisation system installed in connection with a pair of Scotch type marine boilers, and which gave perfect satisfaction. As the job was afloat and in salt water it was considered out of the question to use a steam atomisation system, even though it would have been less expensive to install. The oil was carried in the fore peak tank and a 4 in. suction pipe led from its after bulkhead to the stokehold. On account of the viscosity of the oil, large suction pipes are necessary in order to reduce the velocity and consequently the friction. The oil was pumped by two 3½ in. x 2½ in. x 4 in. steam driven duplex pumps, which, on account of the deleterious action of the oil on rubber, etc., were specified to be fitted with brass rings and valves in the oil end, and to be packed with asbestos. Immediately in front of where the suction pipe entered the pumps, a twin suction strainer was installed, arranged to be cleaned out while steaming.

Steam Supply to Pumps

The steam supply to the pumps was regulated by the oil pressure in the dis-

charge line, the regulating valves being set to the desired pressure, which is usually found by trial. In this particular instance, a pressure of 90 lbs. per sq. in. was found suitable, when using a No. 3 Dahl tip. On leaving the pumps, the oil was piped to a pair of live steam heaters, consisting of a cast iron shell in which a coil of pipe was placed. The oil passed inside the pipe, while steam was admitted to the shell, the temperature of the oil being raised to from 225 to 250 degs. F. A high pressure steam thermometer was installed in the heater outlet in order that the temperature could be ascertained. In a by pass between the pumps and the heater, a Worthington oil meter was installed. To remove any fine particles of grit or pipe scale from the oil, a pair of discharge strainers were installed between the heaters and the furnaces, and as the oil is of much lower viscosity when heated, a strainer of fine mesh can be used on the discharge line.

The header from which the burners were fed was led across the front of the boilers below the furnaces, branches being taken to each burner. The end of the header was connected to the suction pipe in order that a circulation of oil could be obtained on starting up, thus providing heated oil at the burners. The burners themselves, one for each furnace, consisted of a piece of pipe with a special tip at one end having spiral passages leading to a circular hole in the centre.

Fire Regulation

The size of the fire could be regulated by varying the pressure of the oil. If the desired results could not be obtained within the suitable range of pressures, it was a very simple matter to substitute a tip with a larger or smaller hole as the case required. With the before-mentioned pressure, a tip with a 1-32 in. hole gave very good results. The furnaces were 37 inches in diameter. The outer end of the burner had a special union connection to the oil pipe branch, and could be removed by the slackening of one set screw. If a burner did not work satisfactorily or got choked up, it was the work of less than half a minute to remove it and substitute a spare one. Surrounding the burner tip was a hollow cast iron cone with the apex pointing to the furnace front. The cone was carried on a pipe through which the burner passed and was made conveniently adjustable, in and out. Its correct adjustment was an important factor in smokeless combustion.

The fire bars, bearers and all brick work, were removed from the furnace and new fronts were installed. The fronts were ¾ in. plate and had hinged air doors above and below the burners. Commencing at the front, the furnace was lined with firebrick for about three feet, in order to give protection from the intense heat. A considerable reduction in the consumption of fuel was obtained by the use of spiral retarders in the tubes. It will be noted in this installation that all important items,

pumps, strainers and heaters, were installed in duplicate, the object to avoid a shut down. If this precaution were not considered necessary, a single pump and heater could be used. Strainers should, however, be duplicated. The apparatus for this installation was secured to the stokehold bulkhead, and was so connected up with unions that any piece could be undone and removed for convenient overhaul.

Oil Burning Regulations

Some of the more important regulations which have to be observed in connection with an oil burning system coming under the control of the Canadian Steamboat Inspection are as follows: Storage tanks must be absolutely tight and constructed of not less than ¼ in. plate. The stop valve on the tank end of the suction pipe must be located inside the tank, and the spindle extended through a stuffing-box on the tank top. The idea of this is to prevent leakage from the valve spindle draining into the bilges. Proper ventilation must be provided for the tank. The exhaust steam from the oil heater must not be piped to the condenser; but must be drained overboard or into the bilges.

In any oil installation, ground joint union and regrinding valves are an absolute necessity. After installation and before oil is admitted to the pipes they should have all dirt, pipe scale, etc., blown out with compressed air or steam. It is a comparatively easy matter to clean the pipes when first put up, but it is a different story after they have been filled with sticky oil.

The Economy Feature

As regards the economy of using liquid instead of solid fuel, this simply resolves itself into a question of their relative costs. On the Pacific Coast, where coal contains between 12,000 and 13,000 B.t.u. per lb., and the grade of oil sold for fuel purposes runs from 19,000 to 20,000 B.t.u. a ton of coal is usually regarded as equivalent to from 3½ to 4 barrels of oil. Oil can be wastefully fired just as easily as coal, if not, more so, as there is less labour involved for the fireman if he is economical with his coal. There is the saving of labour handling to be figured to the advantage of liquid fuel. In this particular installation no exact comparison was possible.

All the special apparatus used on this installation was manufactured by the Union Iron Works, of San Francisco, Cal., under the Dahl patents. The work of installation was carried out by the Wallace Ship Yards Ltd. of North Vancouver, B.C. Lunkenheimer regrinding valves, and Dart unions were used throughout.



A Chain of Evidence is the title of publication No. 15, issued by the Morse Chain Co., Ithaca, N.Y. This bulletin, although bearing a sub-title, "Small Power Drives," is not confined to small drives, but includes drives up to 100 h.p.

Smith & Mills High Duty Crank Shapers

*The Product of a Shop Devoted
Exclusively to Shapers*

Perfect in

**DESIGN
CONSTRUCTION
ACCURACY
CONVENIENCE
PRODUCTION**

Early Deliveries on
14, 16, 20 and 25-inch Sizes.

WRITE FOR FULL PARTICULARS
AND PRICES.

The
**A. R. Williams Machinery
Co., Limited**

64-66 Front Street West
TORONTO, ONTARIO, CANADA

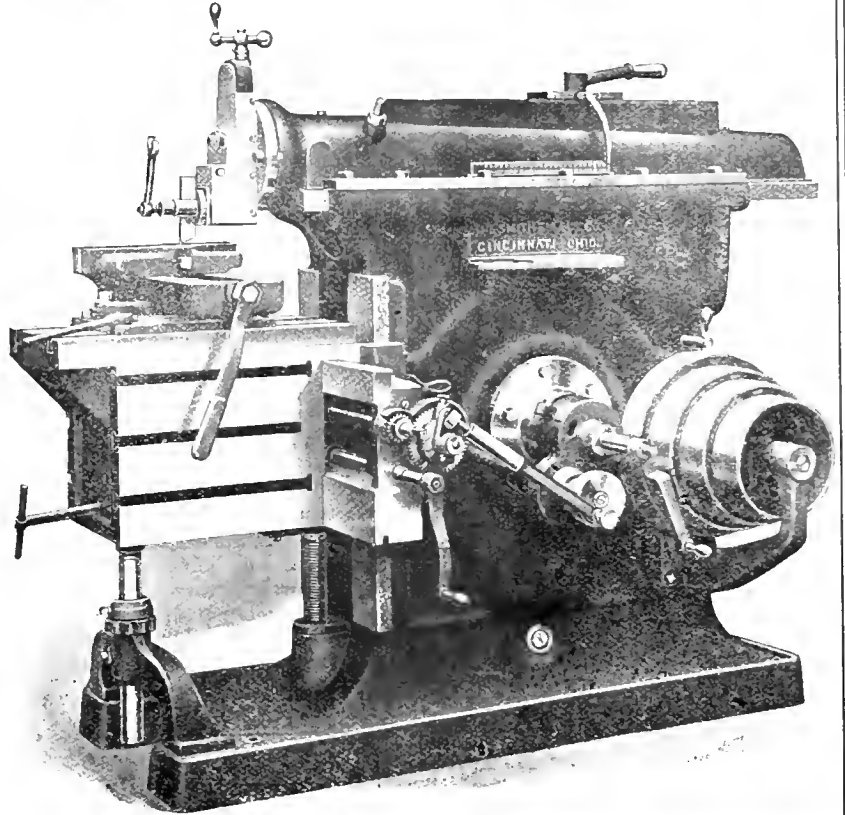

The
BUSY END
of a

Geometric Threading Machine

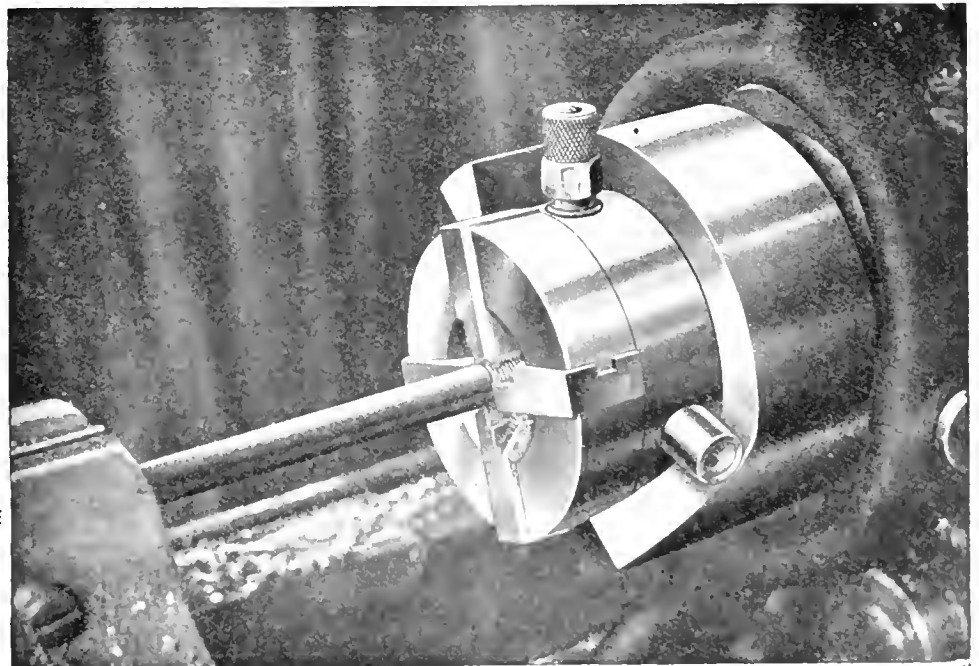

THE above photograph was taken in the plant of the F. L. Jacobs Co., who have a battery of Geometric Threading Machines. The part shown is the threaded end of a brake rod. This year something in excess of 4,000,000 parts of this and similar character will be made in the Jacobs' plant.

Does this mean anything to you? Let us send you our Threading Machine Booklet.

The Geometric Tool Company
NEW HAVEN, CONN., U.S.A.

Canadian Agents: Williams & Wilson, Ltd., Montreal; The A. R. Williams Machinery Co., Ltd., Toronto, Winnipeg and St. John, N.B.

If any advertisement interests you, tear it out now and place with letters to be answered.

INDUSTRIAL ^A_N^D CONSTRUCTION NEWS

Establishment or Enlargement of Factories, Mills, Power Plants, Etc.; Construction of Railways, Bridges, Etc.; Municipal Undertakings; Mining News

ENGINEERING

Wingham, Ont.—The Western Foundry Co. contemplates an addition to its foundry here.

New Glasgow, N.S.—The Nova Scotia Steel & Coal Co. are making considerable extensions to their plant.

Toronto, Ont.—Work has started on an addition to the factory of the Chapman Double Ball Bearing Co. here to cost \$17,500.

Hamilton, Ont.—The Standard Underground Cable Co. has commenced the erection of an addition to its plant to cost \$12,000.

Calgary, Alta.—The Alberta Farmers' Co-operative Elevator Co., is in the market for mechanical equipment for new elevators which will be constructed.

St. Mary's, Ont.—The Detroit Chassis Co., of Detroit, Mich., have written the City Council regarding establishing a factory here for making motor cars, trucks, etc.

St. John's, Que.—The Dominion Crucible Co., a subsidiary of the Dominion Bridge Co., Montreal, will have work commenced at an early date on the erection of a plant here.

Cobalt, Ont.—The management of the Porcupine Premier Mine have recently installed a new compressor plant and towards the end of this year may install a small Hardinge mill.

Trenton, Ont.—Good progress is being made on the new plant for the Imperial Munitions Board by the contractors, the Gaylord Engineering & Construction Co., and the Pratt Engineering Co.

Amherst, N.S.—A fire, with a monetary loss of about \$30,000, occurred at the International Engineering Works on January 21. The fire broke out at the west end of the boiler shop, a building 200 feet by 150. The loss is covered by insurance.

Toronto, Ont.—The site selected by the Imperial Munitions Board for the new steel plant at the Harbor Commissioners Industrial Area, contains sixty acres. An option has been secured on thirty acres to the east with a view to ultimate enlargement. There will be five buildings, one of which will be 300 feet long and 125 feet wide, with an interior clearance of 40 feet in which traveling cranes will be operated. The buildings will be of steel construction and the cost will be well over \$2,000,000 and may run as high as \$3,000,000. There will be ten six-ton furnaces, 25-cycle Heroult furnaces, requiring 2,000 h.p. each to operate, or a total of 20,000 horse power. It is understood that the furnaces have been purchased through the U.S. Steel Corporation. The contract price is said to be \$500,000.

Halifax, N.S.—It is understood that the Nova Scotia Steel & Coal Co. will manufacture 7,000 car axles for the Russian cars now building at the shops of the Eastern Car Co., a subsidiary of the Nova Scotia Steel Co. This action follows the unsuccessful negotiation for this material in the United States during the last two weeks. It is possible that the 24,000 car wheels needed for the same construction may also be made at the shops of the Nova Scotia Steel Co.

Victoria, B.C.—Work on additions to the Ladysmith smelter, formerly owned by the Tye Copper Co., has been commenced under the direction of W. J. Watson, manager. It is proposed to expend approximately \$100,000, the chief improvement being the installation of a converter which will permit of the output of copper matte whereas, hitherto, the plant could produce only blister copper. The new owners have secured additional land and will increase the

was instructed to prepare plans and secure data in the matter.

Toronto, Ont.—The York Township Council will call tenders shortly for the supply of material and construction of water mains in sections A and B of the township's plan. The cost is estimated at \$320,000.

ELECTRICAL

Toronto, Ont.—The Hydro-Electric Commission have leased additional land at the Garrison Commons and will extend their distribution plant there.

Windsor, Ont.—The Hydro-Electric Commission is asking the Council of Windsor to issue \$50,000 worth of debentures for improvements and extensions.

GENERAL

Grimsby, Ont.—The Metal Craft Mfg. Co., propose building a factory here to manufacture steel goods.

Winnipeg, Man.—Fire, recently destroyed the plant of the F. J. Welwood Mfg. Co., at Elmwood. The loss is estimated at \$10,000.

Tillsonburg, Ont.—D. Trevail & Son, South Middleton, whose cheese box factory was totally destroyed by fire in the fall, have rebuilt, and are again about ready for operations.

Toronto, Ont.—Benjamin Moore, Ltd., paint manufacturers, have purchased a site adjoining their plant at West Toronto, and will build a factory, 90 x 132 feet. They have just completed a large addition, and will shortly start construction of a varnish plant.

Tillsonburg, Ont.—The Huntley Mfg. Co., of Silver Creek, N.Y., who recently purchased the plant of the Tillsonburg Electric Car & Coach Co., by March 1 will be equipped to start operations. They will manufacture fifty different lines of milling and canning factory machinery. In the spring a large addition will be constructed with railway sidings.

BUILDINGS

Toronto, Ont.—Gowans, Kent & Co., have prepared plans for a six storey office building to be erected on Front street a short distance east of Bay.

Toronto, Ont.—The Toronto Board of Harbor Commissioners has prepared plans for a large office building to be erected on the water front at the foot of Bay street. It will be five storeys high and cost \$250,000.

CANADIAN GOVERNMENT PURCHASING COMMISSION

The following gentlemen constitute the Commission appointed to make all purchases under the Dominion \$100,000,000 war appropriation:—George F. Galt, Winnipeg; Hormidas Laporte, Montreal; A. E. Kemp, Toronto. Thomas Hilliard is secretary, and the Commission headquarters are at Ottawa.

present daily capacity of 600 tons to about double that amount. Provided machinery now on order is received without undue delay, the plant will be ready for operation in about three months.

MUNICIPAL

St. Mary's, Ont.—The City Council contemplate installing a sewage disposal plant.

Brantford, Ont.—The Township Council are negotiating for the installation of Hydro-Electric power in the township.

Chatham, Ont.—\$45,000 for extensions to the local Hydro-Electric system and \$16,000 for extension of water mains to westerly limits of the city, passed by council, January 8.

Hamilton, Ont.—James Bain, engineer at the Beach Pumping Station, has suggestion that a turbine and a 10,000,000-gallon pump be installed at a probable cost of \$50,000 to tide over the situation until times become normal again. He

Aikenhead's

A.K.

MOTOR AND CONTROLLER



The A.K. Motors are built for high efficiency and long durability.

Single Phase, Variable Speed Type will run on 110 or 220 volt, 25 or 60 Cycle.

These come in sizes from 1/4 H.P. up and are stocked, complete with a 12-speed Controller, in Toronto.

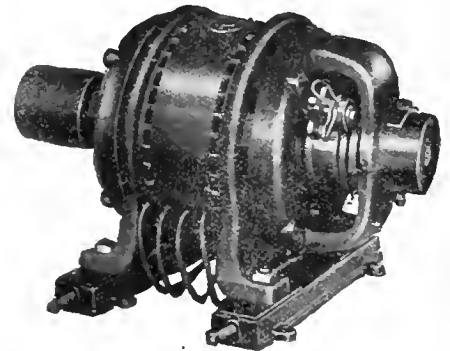

Aikenhead Hardware Limited, 17, 19, 21 Temperance St., Toronto, Can.

Don't Keep It--Sell It!

- If you have a
- a lathe
 - a drill
 - a milling machine
 - a planer
 - a chain block
 - a chuck
 - a motor
 - a crane
 - a stock of belting
 - an engine
 - a compressor

or any other machine shop equipment for which you really have no further use, why not turn it into *cash*?

Someone may be looking for just the machine you may want to sell. Let us bring you together.

A "classified" ad. in CANADIAN MACHINERY, costing a few cents per issue, has done wonders for others. Why not try it?

Turn to the "Classified" section in this issue and see what is being offered and what is wanted at present.

CANADIAN MACHINERY

Classified Advertising Section

143-153 University Avenue TORONTO, ONT.

A Good, Hard and Fast Worker

Superior
Distinctive
Design



The
DE MOOY
IMPROVED
SENSITIVE
DRILLS

are built in two sizes; No. 1 has capacity from 0 to 5-16"; No. 2 from 0 to 1/2"; No. 2 is built in two types, either as Bench or Floor drill.

The machines are built sturdy; compact; convenient; economical and dependable for small accurate drilling.

Write for specifications.

The De Mooy Machine Co.
CLEVELAND, OHIO

If any advertisement interests you, tear it out now and place with letters to be answered.

RAILWAYS AND BRIDGES

Montreal, Que.—Contracts have been let for the new C. N. R. station at the corner of Lagauchetiere and St. Monique Streets. Norcross Bros. will erect the building, which will be some 100 feet square. It will serve as a temporary station pending the erection of the larger permanent structure. Angus Sinclair was given the contract for the excavation work in connection with the large permanent station. The contract will involve the removal of some 250,000 cubic yards of earth, stone, etc.

MARINE

Victoria, B.C.—The City Council have endorsed the petition put out by the Esquimaux Graving Dock Committee, calling on the Dominion Government to take action for the early completion of the graving dock at Esquimaux for which property was purchased at Lang's Cove in 1914. It is well known that the dock completed in 1887 has for a long time been insufficient to take care of modern shipping. This fact was admitted by the Dominion Government as far back as 1912, when steps were taken to enlarge the present dock or purchase a new site whereon a dock could be built large enough for all modern requirements.

TENDERS

Winnipeg, Man.—Tenders will be called until February 12, 1917, for works required for the completion of the new Parliament Buildings, which include the following: Heating and ventilating, electric conduit and wiring. Thos. H. Johnson, Minister of Public Works, Winnipeg.

Winnipeg, Man.—Tenders will be received by R. D. Waugh, chairman of Commissioners, Greater Winnipeg Water District, up to February 5, 1917, for the supply of indicating and recording apparatus for two Venturi meters. Specifications may be obtained at the office of the district, 501 Tribune Building.

Toronto, Ont.—Tenders will be received, addressed to the chairman, Board of Control, City Hall, Toronto, up to January 30, for the installation of a 40-million Imperial gallon centrifugal sewage pump at the main sewage pumping station, Toronto. Specifications and forms of tender may be obtained at the Works Department, Room 6, City Hall.

London, Ont.—Tenders will be received up to January 29, 1917, for the supply and delivery of: (a) Special railroad track work, consisting of five (5) whole and two half crossings of manganese steel construction; (b) two horse-drawn road oil distributors. Specifications, form of tender, etc., can be seen at the office of H. A. Brazier, city engineer.

Ottawa, Ont.—Tenders will be received at this office until February 12, for the supply of: Brooms and brushes, chain, coal, hardware, hose, oils and greases, packing, paint and paint oils, Manila rope, wire rope and steam pipe, valves and fittings, for the requirements of the departmental dredging plant in Ontario and Quebec during the fiscal year 1917-18. These forms of tender can be obtained at the Department of Public Works, Ottawa. R. C. Desrochers, secretary.

INCORPORATIONS

The Metal Craft Co. has been incorporated at Toronto, with a capital of \$40,000, to manufacture all kinds of sheet metal, furniture, etc., at Grimsby, Ont. The provisional directors are: Frank P. Macklem, Hugh D. Walker and E. B. Darley, all of Toronto.

The New Brunswick Sulphate Fibre Co. has been incorporated at Ottawa, with a capital of \$200,000, to carry on a lumbering business and manufacture wood alcohol and calcium carbide, etc., with head office at Montreal. The incorporators are: Gordon W. MacDougall, L. Macfarlane, and W. B. Scott, all of Montreal.

St. Lawrence Smelting & Refining Co. has been incorporated at Ottawa, with a capital of \$100,000, to carry on the business of smelting and refining minerals of all kinds, at Kingston, Ont. The incorporators are: F. H. Markey, Waldo W. Skinner and W. G. Pugsley, all of Montreal.

PERSONAL

Hon. Col. Frederic Nicholls of Toronto, has been appointed to the Canadian Senate. Col. Nicholls is president and general manager of the Canadian General Electric Co., and Canadian Allis-Chalmers Ltd. He is a director of the Canadian Northern Railway and also of a number of industrial concerns.

TRADE GOSSIP

The Hoyt Metal Co., Eastern Avenue, Toronto, have installed a plant for making high-grade wire solder, lead pipe and "Came" lead.

Zepherin Hebert, vice-president of the Montreal Board of Trade for the past year, has been elected president by acclamation. Mr. Hebert is the first French-Canadian president of the Montreal Board of Trade.

The Daylight & Ventilation Co., Stair Bldg., Toronto, are completing the installation of straight push sash operators for controlling 8,000 feet of sash at the Dominion Government Arsenal at Lindsay, Ont. They have also booked an order for similar equipment for the International Nickel Co. new plant at Port Colborne, Ont. This installation will control 12,000 feet of sash.

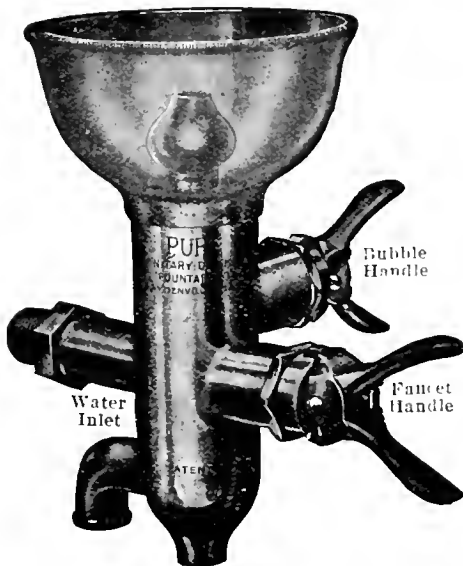

Saving or Wasting?

The manner in which you handle the drinking water problem in your plant may seem to be a small matter to you—but investigate. The results will be surprising.

The old-time faucet is costly. Running hour after hour, day after day, its ceaseless flow is costing you money, yet without any better service.

Puro Saves 35%

A Puro Sanitary Drinking Fountain will cut that water bill 35%. We can prove that it has done that for others.

It will give every employee a safe, saner draught of bubbling water free from the contamination of the common drinking cup.

In a word, it is the only sanitary Drinking Fountain that is really safe, sanitary, simple, automatic in control, and easy to attach.

"PURO - FY"

(MADE IN CANADA)
YOUR WATER SUPPLY

Puro Sanitary Drinking Fountain Company
147 University Ave., Toronto, Canada

HAVE YOU

read pages 66 to 71?
Turn to them now
and see for yourself
whether or not they
are of interest.

Canadian Machinery
Classified Advertising Section

Industrial Utilization of Straw.—Lord Shanghnessy has authorized a well-known chemist in London, Eng., to undertake a comprehensive research with regard to possible use of the straw of wheat, oats, barley and rye, with a view to its industrial utilization. In Western Canada, it has been the custom to burn this straw as refuse.

To Develop British Trade.—C. Hamilton Wickes, the British Government Trade Commissioner of Canada and Newfoundland, is shortly leaving for England. While there he will visit the principal industrial centres throughout the United Kingdom, on the subject of British trade and its future development in Canada.

The Canadian H. W. Johns-Manville Co. held a convention of salesmen and managers of various departments at the King Edward Hotel, Toronto, during the week of January 15 to 20. Over thirty-eight salesmen from all parts of Canada were present at the convention, which was presided over by W. M. Hiller, general manager of the Toronto branch.

British Firm Winner.—Advices from Washington, D.C., state that contracts for armor piercing navy projectiles of the 14 and 16-inch type, totalling \$3,141,000, have been awarded by Secretary Daniels to the Hadfields, Limited, the English munition company. Bids from American firms were more than \$200 a shell in excess of that submitted by Hadfields, and deliveries covered over twice the length of time.

British Export Restrictions.—The Department of Trade and Commerce, Ottawa has issued a form of affidavit to be used in connection with exporting of goods from the Old Country to Canada as required by the Ministry of Munitions. The affidavit is for information required to be filed by actual users with the Department of Trade and Commerce in connection with all applications to receive shipments from the United Kingdom of goods upon the British Export Restriction List.

The Spence Co. have opened an office in the Birks Building, Montreal, and will handle an extensive line of steel products, such as bars and shapes, reinforcing bars, tool steel, etc. The company are direct distributing agents of various mills in the States, and have made favorable arrangements for the delivery of goods. The Spence Co. will also supply the Canadian market with ingot metals, machinery, beltings, chemicals and ores. The steel department will be under the supervision and management of Lionel L. Phillips.

Bauxite in British Guiana.—In the past year there has been considerable excitement in Dutch Guiana due to the discovery of large deposits of bauxite on the Surinam River, some hours' journey from Paramaribo, and also on the Demarara River in British Guiana. The Aluminum Co. of America is already developing deposits and arranging for transportation to the United States coast and gulf ports. One ship has already been purchased and will be taken to the

PATENT ATTORNEYS

BABCOCK & SONS
ESTAB 1877
PATENTS-TRADE MARK-DESIGNS
IN ALL COUNTRIES
Book "Patent Protection"—free. Master of Patent Laws, Formerly Patent Office Examiner
99 St. James St., - Montreal, Que.
Branches: Ottawa, Washington.

RESEARCH BUREAU
REPORTS BY EXPERTS ON SCIENTIFIC, TECHNICAL AND INDUSTRIAL DEVELOPMENT.
SPECIAL RESEARCHES ARRANGED.
PATENTS, TRADE MARKS, ETC.
HANBURY A. BUDDEN CABLE ADDRESS
712 DRUMMOND BLDG., MONTREAL "BREVET"

PATENTS
Fetherstonhaugh & Co.
Patent Solicitors, Head Office,
Royal Bank Bldg., Toronto,
Ottawa Office, 5 Elgin St.
Send for our Plain Practical
Pointers. Copy of National
Progress, in which our patents
are advertised, mailed free.

PATENTS PROMPTLY SECURED

In all countries. Ask for our Investor's Adviser, which will be sent free.
MARION & MARION, 364 University St.
Merchants Bank Building, corner St. Catherine St., MONTREAL, Phone Up. 6474 and Washington, D.C., U.S.A.

Don't Stop!
Go right on to page 66.
You'll want to stop there a while.

GAUGES
DIES, TOOLS AND REPAIRS
OXY-ACETYLENE WELDING
WORTH ENGINEERING CO.
163 Spadina Ave., Toronto, Ont.
Phone Adel. 3734
B. H. AYLSWORTH A. E. HACKWORTH

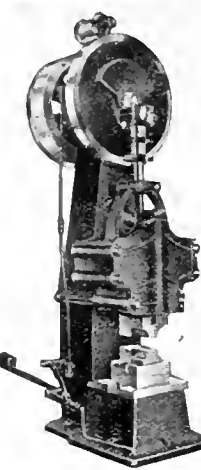

The "Dupont" PATENT Power Hammer

The strength, durability, economy of power and simplicity of adjustment of the Dupont Power Hammer make it a decidedly superior tool.

Made carefully from carefully selected, high-class materials.

Positively Guaranteed

Seven sizes.
With rams from 35 to 300 lbs.

Write for full details.

THE PLESSISVILLE FOUNDRY
Plessisville, Que.
Ontario and Western Agents:
The General Supply Co. of Canada Ltd.
Ottawa Toronto Winnipeg

OVENS
Enameling and Varnishing.
OVENS Heated by
GAS, ELECTRICITY, STEAM or COAL
Write for New Pamphlet Just Issued
Pranford Oven & Rack Co., Ltd. Toronto, Canada

Oxy-Acetylene Welding

We can give the best of service in all kinds of welding repair jobs. We have successfully repaired the most difficult jobs. Our work is high-class and our prices moderate.

Send us your work or write us regarding it
TORONTO WELDING CO.
26 Pearl St., TORONTO

THE IRON WORKS LIMITED
Successors to
Owen Sound Iron Works
Owen Sound, Ont.
Engineers
Boiler-makers
Founders
Machinists

Tank Work
Smoke Stacks,
Grey Iron and
Brass Castings,
Special Machinery
Made to Order

Forgings Cranks, Connecting-Rods, Valves and any other special work.
MACHINE HANDLE FORGINGS
Blue finish, ready for use.
Write for prices to
ST. CLAIR BROS., Galt, Ont., Can.

See
Page 66

Davis-Bournonville Oxy-Acetylene Welding and Cutting Apparatus Leads the World

Over 2,400 plants in daily operation. Medal of Honor, Highest Award at Panama Exposition.

PORTABLE GENERATORS
STATIONARY GENERATORS
WELDING TORCHES
CUTTING TORCHES
REGULATORS
HOSE
CARBIDE
WELDING RODS
FLUX
CARBONITE RODS
GOGGLES
CARBON REMOVERS
PORTABLE TRUCKS
COMPRESSED ACETYLENE

Price list and full particulars on request.

Carter Welding Co.
9-11 Sheppard Street
TORONTO, ONT.
Phone Adelaide 2841
Canadian Agents for
The Davis-Bournonville Apparatus

coast at the opening of navigation this year. Alterations to fit the vessel for the trade are under way.

Haileybury School of Mines.—The new engineering laboratories of the Haileybury School of Mines, at Haileybury, Ont., are nearing completion, and the school is now procuring their machinery and equipment. The laboratories will comprise a complete machine shop, carpenter shop, blacksmith shop, small size contractor, cyanide mill, flotation plant, and assay office, and will contain most of the machines usually met with in these lines. The school has the co-operation of the mines of the Cobalt district, and of manufacturers of mining and other machinery, and is always pleased to make arrangements with manufacturers and have their machinery represented in the school.

Blast Furnaces in France.—The number of blast furnaces in France in unoccupied territory is now forty-eight in blast, according to *L'Usine*, Paris, with eight ready to be blown in as soon as coke can be obtained. These furnaces are situated on the coast at Calais, Outrean, Panillae, Trignae, and Le Boucean; in central and southern France at Le Creusot, Chasse, Givors, Firminy, Alais, Monthuon, Decazeville, Furnel, Saut-du-Taru, Tarascon-sur-Ariège and Ris. The furnaces use both French and foreign ore, and their present output is only from 110,000 to 120,000 tons per month. The basin of Nancy furnishes over 50,000 tons of ore per month, while the plants on the coast get ore mostly from Bilbao, Spain.

Strikes During December.—The monthly statement of the Department of Labor for last month, issued on January 15, indicates that the number of strikes beginning in December was three as compared with fourteen in November. There were altogether thirteen strikes in existence during December, ten of which began before the first of the month. In the three new strikes of the month, three firms and 627 employees were involved, while in the ten strikes commencing before December, 29 firms and 715 employees were involved, making a total of 32 firms and 1,342 employees involved in the 16 strikes in existence during December. Settlements were effected in the case of four of these disputes, leaving nine unsettled strikes in existence at the end of December. Coal miners were affected by one, and clothing workers by two of the December strikes.

CATALOGUES

Stellite.—Two bulletins have been issued by the Deloro Smelting & Refining Co., Toronto. One of these bulletins contains directions for using "Stellite" tools, while the other deals with "Stellite" as a money-saver. In the latter bulletin, which was written by Elwood Haynes, the subject is treated from an efficiency viewpoint.

File Sharpener.—Bulletin O describes the "Buckeye" file sharpening machine made by the McLeod Co., Cincinnati, Ohio. The principal features of this machine and its method of operation are described at length, accompanied by illustrations.

The International Malleable Iron Co., Guelph, Ont., have issued a new catalogue, J, showing a large variety of cast iron and malleable fittings which they manufacture. A very complete line of fittings is illustrated accompanied by lists covering the various sizes. The concluding pages of this catalogue deal principally with cast iron sectional and other types of boiler, heating systems and waterworks supplies.

Optical Pyrometer.—Barnes-Morris, London, England, have recently issued a catalogue dealing with the "Wedge" optical pyrometer. A full description is given of the instrument covering its salient features and method of operation. The field of application is dealt with in connection with various processes of heat treatment, such as annealing and hardening, and also in connection with different industries, particularly glass manufacture.

High Speed Drills, Reamers, Etc.—Catalog No. 15 deals with an interesting line of Celfor high-speed twist drills, reamers, countersinks, chucks, sockets, flue cutters, etc. The catalogue is fully illustrated and contains prices and particulars of each size of tool. The concluding pages of the catalogue contain a telegraphic code, speed and feed table for Celfor drills, and a table of decimal equivalents. Copies of this catalogue may be obtained from the Clark Equipment Co., Buchanan, Mich.

Storage Battery Trucks for industrial plants is the title of Bulletin No. 200, recently issued by the Jeffrey Mfg. Co., Columbus, Ohio. The bulletin contains illustrations, specifications and descriptions of various types of storage battery trucks for industrial plants, warehouses, factories, foundries, etc. The illustrations show various types of trucks working under different conditions featuring their wide range of operation. Copies of this bulletin can be obtained by writing to the company's Canadian office in the Power Building, Montreal.

Heat Treatment.—Bulletin 866—A, entitled "Apparatus for the Location of Thermal Transformation Points" which has recently been published, describes and illustrates apparatus developed by the Leeds & Northrup Co., Philadelphia, Pa. The apparatus is fully described, as is also the method of determining the critical or transformation temperature on which certain physical and chemical changes take place when the metal is heated and cooled. An interesting series of charts is shown exhibiting the transformation points in samples of carbon steel containing various percentages of carbon. The catalogue contains considerable interesting matter on heat treatment of steel and other metals of particular value to designers of automobile and other classes

of machinery, where the requirements are exceptionally stringent.

BOOK REVIEWS

Railway Regulation.—A recent publication of LaSalle Extension University which has become of special interest to the public from recent developments in the transportation world is Railway Regulation, by Professor L. Leo. Sharfman, of the University of Michigan. This is the only recent and authoritative summing up of the whole subject and should be read by all railroad men.

Specific Gravity Studies of Illinois Coals.—Experiments conducted at the Engineering Experiment Station of the University of Illinois have established a relationship between the ash content of bituminous coal and its specific gravity which makes possible rapid estimation of the ash and moisture content. These tests have also shown that a knowledge of the specific gravity of coal simplifies the problems of estimating tonnages underground and in storage, and of determining the adaptability of coal to treatment by the washing process. The experiments were made by M. L. Nebel and the results are published as Bulletin No. 89 of the Engineering Experiment Station, copies of which may be secured upon request from W. F. M. Goss, Director, Urbana, Ill.

Investigation of Coals in Canada.—The Department of Mines, Ottawa, has issued bulletin No. 338 supplementing report No. 83 under the title of "Investigation of the Coals of Canada with reference to their economic qualities. It will be remembered that the original investigation was conducted at McGill University, Montreal. This bulletin No. 338 deals with the "Weathering of Coal" and covers an extended study of oxidation of coal as a part of the original investigation referred to above. The subject is an important one in Canada where climatic conditions necessitate the storage of large amounts of bituminous coal at central distribution points. The bulletin contains much interesting data obtained from a series of laboratory experiments on the oxidation of coal at low temperatures and also studies of coal storage both at the mines, in Montreal, and also in other cities. The bulletin was compiled by Dr. T. B. Porter and can be obtained from the Government Printing Bureau, Ottawa.

RUSSIAN ASBESTOS INDUSTRY

ASBESTOS is found in insignificant quantities in the Caucasus and in Siberia, but about 99 per cent. of the Russian output is mined in the Ural mountains. Some of the best asbestos mined in the Urals is produced at mines 60 miles northwest of Ekaterinburg, in a zone of serpentine rocks, which extends about 6 miles and is about 1,400 yards broad. The quality of this asbestos is believed to be as high as that of

STEEL CASTINGS

We are in a position to make immediate delivery of all kinds of steel castings, 100 lbs. and heavier.

Send us your next order.

Dominion Steel Foundry Co., Ltd.

Hamilton, Ont.

We are qualified Tool, Die, Jig, Gauge and Fixture Makers.

WRITE US.

Windsor Machine & Tool Works.
WINDSOR, ONT.

MORTON MANUFACTURING CO.
PORTABLE PLANERS
DRAW CUT SHAPERS
SPECIAL DRAW CUT R R SHAPERS
FINISHED MACHINE KEYS
STATIONARY & PORTABLE KEY WAY CUTTERS
SPECIAL LOCOMOTIVE CYLINDER PLANERS
OFFICE AND WORKS: MUSKOGON HEIGHTS U.S.A.

"Barnes-Made"
SPRINGS

are unusual in service and wear

They are the result of sixty years' experience, unsurpassed equipment and highly skilled workmanship.

A trial will convince you that "Barnes-Made" Springs are the best buy.

Established 1857

THE WALLACE BARNES COMPANY
218 South St., Bristol, Ct., U.S.A.

Makers of "Barnes-made" Products
Springs, Screw Machine Products, Cold Rolled Steel and Wire

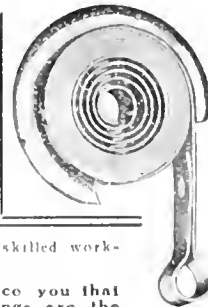

METAL STAMPINGS

We are manufacturers of stamped parts for other manufacturers.

We do any kind of sheet metal stamping that you require. Our improved presses and plating plant enable us to produce the finest quality of work in a surprisingly short time.

We can finish steel stamping in Nickel, Brass or Copper.

Send us a sample order.

W. H. BANFIELD & SONS

372 Pape Avenue, Toronto, Can.

MAPLE LEAF
STITCHED COTTON DUCK
BELTING
DOMINION BELTING CO. LTD.
HAMILTON CANADA

"HAWK" D
CHROME
VANADIUM
STEEL



Will
 Give You
 Exceptional

Shell Forging Production

**WITHOUT AN EQUAL FOR
 BOTH FIRST AND
 SECOND OPERATION
 PUNCHES.**

Comes to you heat-treated
 and ready for use.

It does not stick to the
 work.

There are many cases where
 each punch has turned out
 over 2,000 shells.

It means more shells, per
 machine per day.

**STEEL OF EVERY
 DESCRIPTION.**

**Hawkridge Brothers
 Company**

303 Congress St., BOSTON, MASS.
 U. S. A.

Canada and Piedmont. The veins are directly broken off either by hand or by a hard hammer. The operation of mining asbestos in the Urals is of a primitive character, but in some cases the production is being made more systematic.

Ekaterinburg Asbestos Mines and Their Output

The most important of the Ekaterinburg asbestos mines are the Vosnesensky Zoe-Anonsky asbestos mines, situated nineteen miles from the station of Bazhenof, on the Perm-Tyumen railway. A third of the asbestos produced in the Urals is obtained here and all the asbestos produced was dispatched abroad, untreated, through Reval. The Shehongy asbestos mines in the village of Mostovskiy produce less than the above mines, all the asbestos produced being worked up in the factory, where sheeting, bands, twine, insertion, thread, etc., are made. The Govorikhinsky asbestos mines lie in a line with the Vosnesensky mines and yielded 3,183 tons of asbestos in 1911. Six miles from the Meivo-Shaitansk factory of the Alapievsky Mining Works are the Kirtanovsky asbestos mines, with a sorting factory where 2,000 tons of asbestos can be sorted per annum. Close to these mines are the mines of the Russo-Italian Asbestos Co., the N. V. Mikhanov Co., the "Uralite Co.," etc. The following figures show the output of the Ural (Ekaterinburg) asbestos from 1906 to 1913: 1906, 8,001 short tons; 1907, 8,743 short tons; 1908, 10,694 short tons; 1909, 13,129 short tons; 1910, 10,936 short tons; 1911, 15,872 short tons; 1912, 16,584 short tons; 1913, 16,661 short tons. Practically the whole of the output was exported via Riga.

Other Mines of the Urals

North of Ekaterinburg asbestos is found in the Bogolssof mining area, in the Kortiakovsky mines (where the vein is about 2 feet thick), near the Alapievsky works, the Venansky works, on the river Uktussa, near the Beresovka works, etc. In the southern Urals asbestos deposits are found at the Khristogor and Petropavlovsky ore mines, near the Miask works on the river Krasnacht, in the Gavriloof copper mines (of excellent quality), in the Atliansky gold placer, near the river Imian Yurt (in talcous schist); there are veins of asbestos near the Kisnikaiievsky copper mine at the foot of the Naralinsky hills; also amongst the serpentine of the river Kara, near the Kachinsky factory, and along the river Guberle, near the fort of that name. The best mineral is considered to be that of the Asbestovoy hill, on the river Sissert, and the asbestos deposits of the Shelkovoy hill, on the land of the Nizhni-Tagil works, between the Shouralinsky and the Tenloy hills. To the south of the Ural range of hills in the Government of Orenburg, there are some exploited asbestos mines—the Natalievsky in the Upper Ural district, the Issergansky in the Orsk district, and the Kholmisty in the Troitzk district.

The following companies have joined the syndicate of Ural asbestos producers: (1) Vosnesensky asbestos mines, with an annual output of 3,106 tons; (2) Yakovley Sucees., with an annual output of 1,806 tons; (3) Poklevsky-Kozell Sucees., with an annual output of 5,416 tons; (4) Korievo asbestos mines, with an annual output of 2,709 tons; (5) Girard de Soukanton, with an annual output of 3,611 tons; (6) Russo-Italian Asbestos Mining Co., with an annual output of 1,806 tons; total, 18,454 tons.

Exports of Asbestos

It is stated that all the companies operating in this district are privately owned and managed. The present transport facilities from the mines are confined to the single-track line of the Perm Railroad, connecting with the Northern Railroad to Petrograd. Asbestos is now on the embargo list, but application for special export licenses may be made to the Department of Customs, Petrograd. Even should such license be granted, the great congestion on all the railroads and in all the parts of Russia makes transportation extremely difficult. Under a recent order of the Russian Government no goods other than those approved by the Government as being specially imported for military purposes are allowed to enter Russia by any of the White Sea ports. This, of course, reduces the amount of available tonnage, as fewer ships will arrive than formerly.

According to official statistics, the exports of asbestos from Russia for the last seven years were as follows:—1909, 9,160 short tons; 1910, 9,689 short tons; 1911, 13,524 short tons; 1912, 15,547 short tons; 1913, 13,669 short tons; 1914, 8,577 short tons; 1915, 975 short tons. These exports, before the war, went to Germany, Austria, the United Kingdom, Belgium, and the Netherlands.

Asbestos in the Caucasus and Siberia

Asbestos is produced in the Caucasus in an insignificant quantity in the Sharopon district of the Kutais Government at the Vzhinevi asbestos mines. In the same Government of Kutais asbestos is known to exist far from the deposits already named to the north-west, in the Leebgoumsky district in the Savanetsky police circuit. It is also found in the extreme south-eastern corner of the Caucasus, not far from the Persian frontier, 12 miles from the town of Shusha.

In Siberia, asbestos is exploited only in the Government of Irkutsk in the Angar district at the Angar asbestos mines. In the Government of Yenissei there are asbestos mines on the left bank of the River Kamuisht, near the Saksar and the Ak-kay hills, near Bishtak hill, at a distance of 25 miles from the village of Askeisk, and on the River Karagan, on the boundary of the Mausky and the Servievsky gold placers. In the Tomsk Government it is found in the system of the River Katum, in the Semiréchensk territory, on the northern slope of the Dzhiela range, in the Dzulan-Arvehsky district, and in the Transbaikal province, in the serpentine of the Klinchinsky ore mine, near the Shilkinsky factory, and

in the neighborhood of the tin mines of the Nerehinsk circuit.

On the Mongol-Dabansky gold placers (now worked out), which belong to the Crown, very rich asbestos and mica mines have been discovered. The Mongol-Dabansky gold placers are situated on the River Mongol-Daban, which falls into the River Didi, a tributary of the River Oka. The new mines lie 75 miles from the station Zima, on the Trans-Siberian Railway.—U. S. Commerce Report.



THE TRANSPORTATION OUTLOOK

THE Canadian Bank of Commerce, in its monthly commercial letter for January, says:—"For the time being the outlook for all classes of transportation companies is, in respect of volume of business, very satisfactory. The drawbacks being encountered are lack of labor and rolling stock, and, in the case of waterborne traffic, the shortage of tonnage. The gross earnings of the railroads are higher than those of last year or of any previous year. Complaints of delays in shipping and of actual car shortage continue to be made, an indication of the activity of general business as compared with former years.

"In the ease of lake shipping there is little doubt but that there will be for some years to come abundant employment for a larger tonnage than is at present in service. British registered steel tonnage on the Great Lakes is now 218,019 tons, as compared with 286,121 tons at the close of the season of 1915. The tonnage of the new vessels added to the lake service during the year amounted to 12,218, and that of the vessels purchased from the United States and added to British registry to 15,349 tons. The decline is due to the transfer to ocean service of 50 vessels aggregating 95,669 tons.

"This decline in tonnage is serious in view of the expanding volume of lake traffic, and under the circumstances it is reasonable to assume that Canadian shipbuilders have before them a period of unusual activity. A large proportion of the total lake freight consists of iron ore, and the carriage charges per ton at present are \$1.25, as compared with the normal rate of 50 cents, a marked indication of the general increase in the cost of transportation."



TRADE OF THE DOMINION

A CANADIAN trade total of \$1,700,563,269 for the nine months ending with the opening of the new year is shown in the monthly statement issued on Jan. 22, by Hon. Dr. Reid, Minister of Customs. For the corresponding months of 1915 the total Canadian trade was \$1,012,486,000. The statement shows continued growth in the export trade of the Dominion. The total exports for the nine months ended December 31 last of Canadian products were \$861,629,000, as against \$511,534,000 for the corresponding period of the previous year. Of

WM. MUIR & CO., LIMITED
 Manchester, England.
 Machine Tool Makers.
Specialties: Patent Puncher Slotting Machines, Milling Machines, Boring Machines.
Agents: Messrs. Peacock Bros., 68 Beaver Hall Hill, Montreal.
 Send for catalogue.

JOHN STIRK & SONS, Limited
 HALIFAX, ENG.
MACHINE TOOLS
Agents—The A. R. Williams Mcy. Co., Ltd.
 Toronto, Winnipeg, Vancouver, St. John, N.B.

BERTRAMS LIMITED
 Engineers
 Sciennes, EDINBURGH
 PAPER MILL MACHINERY
 and
MACHINE TOOLS FOR IRON WORKERS
 Catalogues offered to Purchasers.

WIRE SPRINGS
 OF ALL KINDS
 Machine Springs, Valve Springs, Automobile Cushion Springs, etc., of a quality that defies competition. Tell us your requirements. Send sample or specification for price.
JAMES STEELE, LIMITED
 QUELPEL, ONTARIO

Quality is Highest—Not the Price
Dickow's Guaranteed 10-Inch Universal Index Centers
 You save from \$50 to \$125 on first cost, and many times that because of their simple construction and great ease of operation. They embody the maximum of accuracy, simplicity and durability.

 Get the Original—Beware of Imitators
 Sold by all dealers. Write to-day for particulars
 Fred. C. Dickow, 35 So. Desplaises St., Chicago, Ill., U.S.A.

Oil Tempered Steel Springs
 —for every purpose and the best for each use.
 Special styles of all kinds to order.
THE CLEVELAND WIRE SPRING COMPANY
 Cleveland, Ohio
 U.S.A.

BOLTS
 Our large stock of Machine Bolts, Rivets and Washers assures quickly filled orders and prompt shipment. One quality only—The Best.
 Send a trial order.
LONDON BOLT & HINGE WORKS
 London Ontario

Special Machinery
 MADE TO ORDER
Mill Machinery, Engine Work
Grey Iron and Brass Castings
 TRY US FOR GENERAL REPAIRS
ALEXANDER FLECK, LIMITED
 (Vulcan Iron Works) OTTAWA, ONT.

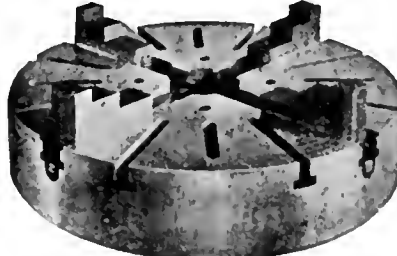
We Know
 you are anxious to buy
Canadian Made
 goods.
The Imperial

Chuck
 is manufactured by
Ker & Goodwin
 Brantford, Canada

Let Arithmetic Convince You

Take a pencil and paper. Put down the number of men who use files in your shop.

Reckon up the probable number of minutes given by each one and by all per day to file work. Calculate this for 300 days, a working-man's year. Calculate the cost of file work for all your men for a whole year at local wages per hour. Add to this the cost of files, merchandise, depreciation charge. Now you'll have a surprise, and when we tell you that

Delta Files

save man-time because they cut faster than any other file made, and that they outlive all other files because they retain their cutting edges longer than any other files will.

You have something to consider very seriously, and we believe that you'll agree with us that Delta Files are at least worth investigating.

A shape and size for every purpose. Delta Files are the only files of from 3 to 24 inches long, made absolutely of erucible steel.

Send for a sample file—to prove it.



DELTA
DELTA FILE WORKS

PHILADELPHIA, PA.

CANADIAN AGENTS:

H. S. Howland, Soos & Co., Toronto;
Starke, Seybold, Montreal;
Wm. Steirs, Soos & Morrow, Halifax;
Merrick-Anderson Co., Winnipeg.
ALL LEADING JOBBERS

WEBBER BROS. MACHINE COMPANY

Gear Blanks, Shell Punches,
Boring Bars, Special Tools.

*Machinery of all kinds
built to your specifications.*

Better Work. Reasonable Prices.

848 Dupont St., Toronto.
Phone Hill. 2746

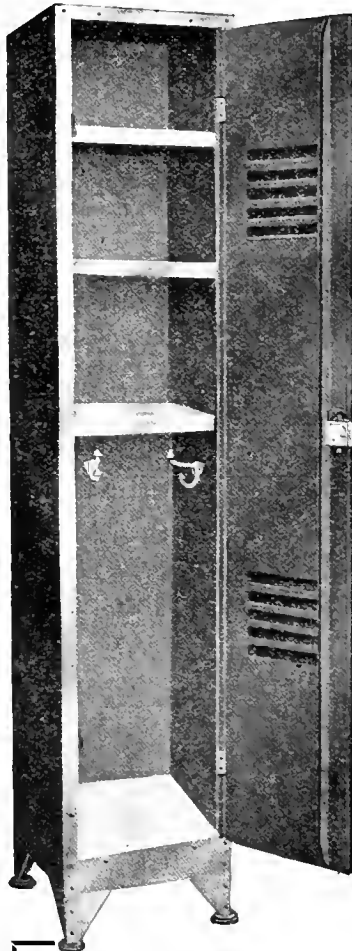

An Ideal Locker for Clothes and Personal Tools

This combination Tool and Clothes Locker will be very useful to the mechanic because it provides ample space for clothes and a safe place for his tools.

Built for life-time service. Supplied in unit or group construction.

We also manufacture STEEL SHELVING FOR ALL PURPOSES. Drop a line for full details.

**CANADA WIRE & IRON
GOODS CO.**

HAMILTON ONTARIO
Eastern Representative: H. E. O. Bull
184 Mance St. Montreal, P. Q.

the exports, domestic manufactured articles lead with \$317,841,000 for the nine months, with agricultural products a close second with \$317,451,000. The figures for the same period of 1915 were, manufactures \$119,399,000, and agriculture \$202,506,000.

The exports of animal products also show a substantial increase for the nine months, with \$93,586,000 as against \$78,559,000; products of the mine, \$63,725,000 as against \$49,034,000; fisheries, \$18,075,000 against \$16,103,000, and the forest \$46,138,000 against \$42,184,000.

The imports, exclusive of coin and bullion, for the past nine months were \$602,866,000, made up of \$330,791,000 dutiable goods, and \$272,075,000 free goods. The imports for the same period of 1915 were \$197,950,000 dutiable goods, and \$145,972,000 free goods, a total of \$343,923,000. Duty collected was \$106,378,000 as against \$71,305,000.

For the month of December last the exports exclusive of coin and bullion were \$130,037,000, and the imports \$68,014,000. For December, 1915, the exports were \$92,171,000, and the imports \$45,690,000. The increase in exports over imports for the nine months, exclusive of coin and bullion was \$258,763,000.

FUTURE TRADE INFLUENCES IN SOUTH AMERICA

THE possibilities of Canadian trade expansion in the future with South American countries is great enough to demand present attention where it is possible to give it, and in view of the important British interests existing there, the opportunity for Canadian business would seem to be already waiting. The fact remains, however, that in Brazil especially, German influence has been particularly active for many years, and the possibilities of British influence being discounted under present conditions was referred to by Miss Edith Browne, F.R.G.S., in a recent lecture at the Royal Colonial Institute on "Possibilities for British Trade in South America after the War"; her remarks applying with considerable force to future efforts on the part of our manufacturers in this country.

Referring to statistics, they were not always easy of assimilation, besides having a limit to their reliability; however, it might be stated, by way of illustration, that Brazil alone, is as big as the whole of the United States without Alaska. All the chief South American republics have recently made great progress and their purchasing power has also increased enormously. It was desirable, however, to remember that the railways and harbours, which had been prime factors in the development of the country, were due to British enterprise, the result to which had been warm friendship between the citizens and the British.

KINDLY MENTION THIS PAPER
WHEN WRITING ADVERTISERS

CANADIAN MACHINERY

AND MANUFACTURING NEWS

A weekly newspaper devoted to the machinery and manufacturing interests.

Vol. XVII.

TORONTO, FEBRUARY 1, 1917

No. 5

EDITORIAL CONTENTS

Engineering Laboratories of the University of Toronto	75-82
General	82
Obtaining Draught Without High Chimneys.	
Editorial Correspondence	83-85
Preliminaries in Machine Part Production Methods—III	
Course—XII Useful Milling Jig Adjustable Rivet Snap.	
General	86
Canadian Oil Prospects Results from Utilization of Coal	
Internal Combustion Engine Lubrication.	
Spokes in Industry's Wheel	87
William Casey.	
General	87-88
Boiler Inspection at Montreal World Shipbuilding During 1916	
Merge Railways Into One System Hydraulic Resources and Industry.	
Progress in New Equipment	89-91
Column Sensitive Drill Press Special Type Shaping Machine	
Gas Holder Installation Electric Furnace Equipment.	
Editorial	92
Our Munitions Manufacturing Outlook Post War Trade Preferences.	
Industrial Notabilities	93
James Alexander McMahon.	
Selected Market Quotations	94-95
The General Market Conditions and Tendencies	95-98
Montreal Letter Toronto Letter Canada's Prosperous Year	
Trade Enquiries Cuban Demand for Gasoline Motors	
Enlarged Canadian Trade Intelligence Service Canadian Commercial Intelligence Service.	
Industrial and Construction News	99-100

THE MACLEAN PUBLISHING COMPANY, LIMITED

JOHN BAYNE MACLEAN, Pres. H. T. HUNTER, Vice-pres. H. V. TYRRELL, Gen. Man.

Publishers of Hardware and Metal, The Financial Post, MacLean's Magazine, Farmer's Magazine, Canadian Grocer, Dry Goods Review, Men's Wear Review, Printer and Publisher, Bookseller and Stationer, Canadian Machinery and Manufacturing News, The Power House, The Sanitary Engineer, Canadian Foundryman, Marine Engineering of Canada.

Cable Address: Macpubco, Toronto; Atahel, London, Eng.

ESTABLISHED 1887.

CANADIAN MACHINERY AND MANUFACTURING NEWS

PETER BAIN, M.E., Editor. B. G. NEWTON, Manager.
Associate Editors: A. G. WEBSTER, J. M. WILSON, J. H. RODGERS.

CHIEF OFFICES:

CANADA—Montreal, 701-702 Eastern Townships Building; Toronto, 143-153 University Ave., Telephone Main 7324; Winnipeg, 22 Royal Bank Building, Telephone Garry 2313.

GREAT BRITAIN—LONDON, The MacLean Company of Great Britain Limited, 88 Fleet Street, E.C., E. J. Dodd, Director. Telephone Central 12309. Cable Address: Atahel, London, England.

UNITED STATES—New York, R. B. Ingestis, 115 Broadway, N.Y., Telephone Rector 8971; Boston, C. L. Merton, Room 733, Old South Building, Telephone Main 1201; A. H. Byrne, 1101 5-6-7 Fort Dearborn Bldg., 105 W. Monroe St., Chicago, Telephone Rand 444 3234.

SUBSCRIPTION PRICE—Canada, Great Britain, South Africa and the West Indies, \$3.00 a year; United States, \$2.50 a year; other countries, \$4.00 a year; Single Copies, 15 cents. Invariably in advance.

Hendey Experimental 12" Lathe

For the Laboratory or Experimental Department where the best of its kind is wanted, and each machine must be motor-driven, here is the Lathe in this HENDEY 12".

In addition to its complete regular equipment it has Small Tool Cabinet for operators' fine tools, also gear closet for extra gears to cut special threads.

Write for Descriptive Matter.

The Hendey Machine Co.

Torrington, Conn., U.S.A.

Canadian Agents: A. R. Williams Machinery Co., Toronto, Ont.; A. R. Williams Machinery Co., 260 Princess St., Winnipeg; A. R. Williams Machinery Co., Vancouver; A. R. Williams Machinery Co., St. John, N.B.; Williams & Wilson, Montreal.

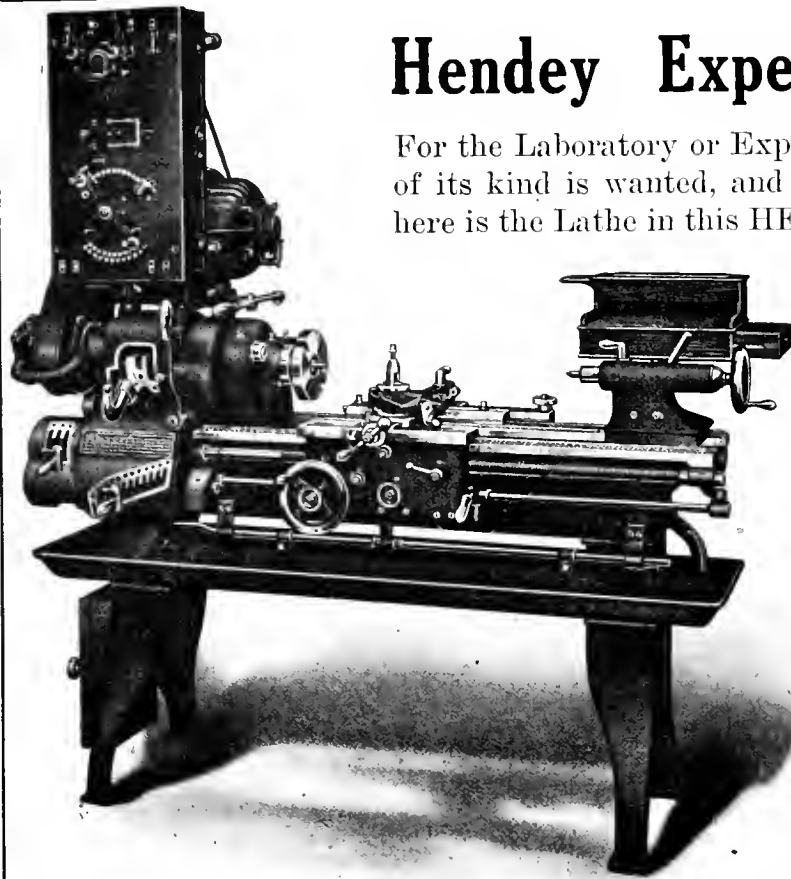

INDEX TO ADVERTISERS

A

Aeroplane Products, Ltd. 118
 Anderson, H. N. 96
 Armstrong Bros. Tool Co. 118
 Armstrong, Whitworth, of Canada, 14
 Atkins & Co., Wm. 191
 Atlas Crucible Steel Co. 14
 Atlas Press Co. 117

B

Babcock & Sons 62
 Baird Machine Co. 118
 Banfield, E. J. 22
 Banfield & Sons, W. H. 64
 Barnes, Wallace, Co. 64
 Beaudry & Co. 117
 Bertram, John, & Sons Co. 1
 Biggs, Patterson Co., The 87 and 83
 Blackall, Fred S. 26
 Blake Pump & Condenser Co. 87
 Blake & Johnson Co., The 112
 Blount Co., J. G. 127
 Boss Lock Nut Co., Front Cover
 Brantford Oven & Rack Co. 63
 Bridgeford Mach. Tool Works 5
 Bristol Co. 116
 Brownell Machy. Co. 67 and 69
 Bryant Chucking Grinder Co. 71
 Budden, Handbury A. 62

C

Canada Machinery Corp.
 Outside back cover
 Canada Sales Co. 74
 Can. Blower & Forge Co. 120
 Can. Bond Hanger & Combing Co. 89
 Can. Desmond-Stephan Mfg. Co. 123
 Can. Economic Lubricant Co. 91
 Can. Fairbanks-Morse Co. 24
 Can. Fastenings Ltd. 74
 Can. Ingersoll-Rand 76
 Can. Inspection & Testing Labora-
 tories, Ltd. 116
 Can. Matthews Gravity Co. 63
 Can. Metal Products Co. 117
 Can. B. K. Morton Co. 10
 Can. Morhead Mfg. Co. 76
 Can. Steel Foundries, Ltd. 7
 Carborundum Co. 111
 Chapman Double Ball-Bearing Co.
 Cincinnati Pulley Mach. Co. 109
 Clark Equipment Co. 75
 Cleveland Milling Mach. Co. 25
 Cleveland Pneumatic Tool Co. 125
 Cleveland Twist Drill Co. 125
 Clippier Belt Lacer Co. 91
 Consolidated Steel Co. 67
 Cook, Asa S., Co. 118
 Corbet Fdry. & Mach. Co. 109
 Cullen Mch. Co., C. E. 68
 Curtis Pneumatic Mch. Co. 92
 Cushman Chuck Co. 116

D

Davis & Co., J. A. 120
 Davis, W. F., Machine Tool Co. 71

Deloro Smelting & Refining Co. 15
 Drury, H. A., Co. 7
 Dr. Moxy Mach. Co. 28
 Dept. of Finance 83, 119 and 131
 Detroit Pneumatic Chuck Co. 107
 Dillon Mfg. Co. 86
 Diamond Saw & Stpg. Wks. 112
 Dominion Mch. Co. 111
 Dominion Steel Fdy. Co. 76

E

Eastern Machine Screw Corp. 72
 Elmes Eng. Works, Charles F. 37
 Erie Foundry Co. 31

F

Fairley-Davidson Steel Co. 9
 Fetherstonhaugh & Co. 62
 Fitzgerald, W. H. J. 68
 Foss & Hill Machy. Co.
 Inside back cover
 Foundry & Mach. Co. 129

G

Gaviner Machine Co. 19
 Garlock-Walker Machy. Co. 148
 Garrin Machine Co. 84
 Geometric Tool Co. 61
 Gibb Instrument Co. 78
 Globe Electric Mach. Co. 104
 Grant Gear Works, Inc. 118
 Grant Mfg. & Machine Co. 123
 Graton & Knight Mfg. Co. 123

H

Hamilton Mach. Tool Co. 19
 Hamilton Gear & Machine Co. 78
 Hamman Car & Eng. Co. 86
 Hanna & Co., M. A. 6
 Harding Bros. 86
 Hawbridge Brothers Co. 65
 Hendey Machine Co. 136
 Hepburn, John T., Ltd. 25
 High Speed Hammer Co. 123
 Binolf Mach. Co. 140
 Hoyt Metal Co. 123
 Hull Iron & Steel Foundries 88
 Hurlbut-Rogers Machy. Co. 117
 Hyde Engineering Works 102

I

Ideal Tool & Mfg. Co. 104
 Independent Pneumatic Tool Co. 110
 Iron Works, The 64

J

Jacobs Mfg. Co. 117
 Jencks Machine Co. 9
 Jersey City Machine Co. 117
 Jones & Glasco 91
 Johnson Mach. Co., Carlyle 89

K

Kasent, Ltd. 127
 Kennedy, Wm., & Sons 25

King, Ltd., Warden 18
 Kidston & Co., A. G. 29

L

L'Air Liquide Society 28
 Lancashire Dynamo Co. 30
 Landis Machine Co. 118
 Leblond Mach. Co., R. K. 11
 Lymburner, Ltd. 28

M

MacKinnon, Holmes & Co. 82
 Main Belting Co. 91
 Manufacturers Equipment Co. 106
 Marsh & Henthorn 127
 Matthews, Jas. H., & Co. 118
 McCabe, J. J. 98
 McCoy-Brandt Machy. Co. 88
 McDougall Co., R., Inside back cover
 McKay Co., James 94
 McLaren Engineering Co. 91
 Mechanical Engineering Co. 91
 Metals Coating Co. 94
 Metalwood Mfg. Co. 27
 Millholland Mach. Co. 85
 Modern Tool Co. 103
 Montreal Machy. & Supplies, Ltd. 104
 Morse Twist Drill Co. 123
 Morton Mfg. Co. 65
 Motch & Merryweather 69
 Murchey Machine & Tool Co. 102

N

National Electric Welder Co. 95
 National Machine Tool Co. 117
 New Britain Machine Co. 20
 New York Machy. Exchange 70
 Nicholson File Co. 31
 Niles-Bement-Pond .. Inside front cover
 Noble & Westbrook 72
 Northern Crane Works 92
 Norton, A. O. 118
 Norton Company 32
 Nova Scotia Steel & Coal 8

O

Oliver Machinery Co. 85
 Ontario Specialties, Limited 119
 Oven Equipment & Mfg. Co. 129

P

Parmenter & Bulloch Co. 116
 Peerless Mach. Co. 112
 Perrin, Wm. R. 27
 Petrie, H. W. 118
 Positive Clutch & Pulley Works. 67
 Pratt & Whitney Co., Inside front cover
 Pringle, R. E. T. 31
 Pure Sanitary Drinking Fountain
 Co. 65

R

Racine Tool & Machine Co. 113
 Reed-Prentice Co. 33
 Reliance Machine Co. 81

Reckert-Shafer Co. 72
 Ridout & Maybee 62
 Riverside Mach. Co. 70
 Robertson Mfg. Co., P. L. 67
 Rockwell Co., W. S. 118
 Roelofson Mach. & Tool Co. 17
 Roper, C. F., Co. 78
 Root & VanDervoort Engr. Co. 21

S

Scott Mach. Co., G. H. 84
 Shuster Co., F. B. 117
 Simmons Mach. Co. 68 and 112
 Sidney Tool Co. 88
 Silberberg, Mortimer J. 131
 Skinner Chuck Co. 116
 Slocum, Avram & Slocum 82
 Smalley-General Co., Inc. 98
 Standard Alloys Steel Co. 12
 Starratt Co., L. S. 113
 Steel Bending Brake Works, Ltd.,
 The 118
 Steel Co. of Canada 3
 Steine Turret Mach. Co. 16
 Steptoe Co., John 27
 Stocker-Rumley-Wachs Co. 71
 Stone Tool & Supply Co., J. R. 106
 Stow Mfg. Co. 110
 Swedish Gage Co. 99
 Swedish Steel & Importing Co. 6

Tabor Mfg. Co. 112
 Taylor Instrument Co. 82
 T. C. M. Mfg. Co. 96
 Thomas Elevator Co. 105
 Tivani Electric Steel Co. 116
 Toronto Iron Works 116
 Toronto Testing Laboratory 76
 Toronto Type Foundry 30
 Turner Mach. Co. 82

T

United States Electrical Tool Co. 110

V

Vanadium-Alloy Steel Co. 13
 Victor Tool Co. 72

W

Walcott Lathe Co. 97
 Warner & Swasey Co. 81
 Wells Bros. of Canada, Ltd. 32
 Whiting Foundry Equipment Co. 131
 Whitman & Barnes Mfg. Co. 133
 Whitney Mfg. Co. 24
 Wickes Brothers 84
 Williams, J. H., & Co. 133
 Williams Machy. Co., A. R. 7 and 61
 Williams & Wilson 65
 Windsor Mach. Co. 63
 Winnipeg Gear & Engr. Co. 119
 Wisconsin Electric Co. 108
 Wright Mfg. Co. 93

Z

Zenith Coal & Steel Products 118
 Zin-Ho Mfg. Co. 110



MAIN BUILDING OF THE UNIVERSITY OF TORONTO, NORTH OF AND FACING THE CAMPUS.

Engineering Laboratories of the University of Toronto

By Robert W. Angus, B.A. Sc.*

The growing recognition of the part played by technical education in national development imparts more than passing interest to the instruction plant by means of which the rising and future generations of this country's engineers are receiving knowledge. A study of the equipment described herewith, should convince even the casual critic that the requirements of engineering education have been recognized and met in a capable manner with a full breadth of vision, a desirable consummation in view of future world trade developments.

THE first engineering laboratory in Toronto was formally opened on February 24th, 1892, in the School of Practical Science, which is now the Engineering Building of the Faculty of Applied Science and Engineering of the University of Toronto. This laboratory consisted of three departments: First, the department for testing materials of construction. Second, the department for investigating the principles governing the application of power, which department included the steam laboratory, the hydraulic laboratory and the electrical laboratory. The third department was an astronomical and geodetic laboratory.

In the steam power department there were two boilers, the larger of 50 h.p. capacity, a 50 h.p. Brown engine with condensers and pumps, and a machine for measuring journal friction and for testing lubricants.

The hydraulic division contained a three-throw pump driven from the Brown engine, a large impulse wheel, and two large tanks for orifice and weir experiments.

Initial Equipment

This equipment served very well at the beginning; there were not many students and thus a large number of pieces of apparatus was not necessary, and the

*Professor of Mechanical Engineering.

apparatus actually installed was so well selected and suited the purpose so well that much valuable instruction was given on the machines mentioned.

As the work expanded and the number of students increased, small additions were made, but up to the time the writer was appointed demonstrator in this work in 1898, the only additions were two reaction turbines, neither of which was set up for operation, and a crude type of centrifugal pump, together with tanks for calibrating the orifices and weirs already mentioned.

During the past decade great advances have been made in the development of power, more especially in Canada, where we have been appreciating to some extent the value of our water powers. The gas engine has also been brought to a high state of perfection and suction gas has presented such great possibilities as to make it an important source of power.

Further, the work of the Engineering Faculty has been recognized by the people of the province in such a way that the attendance has increased by leaps and bounds.

For these and other reasons it has been necessary to increase steadily the equipment of the power department to illustrate the modern methods and also to provide sufficient apparatus for the increased number of students.

As the number of pieces of apparatus

increased the available space became more and more crowded until during the last few years it has been difficult to carry on the work successfully. The steam laboratory had been placed in a comparatively low basement and the moisture and heat produced by the steam made the working conditions very bad.

After careful examination of the whole question, the Board of Governors of the University decided in June, 1908, upon the erection of a new building to accommodate the laboratories for steam, gas and hydraulic work and also for all general mechanical engineering, and the building described in this article is the result.

The money appropriated for the building as erected was between \$85,000 and \$90,000 and for new equipment approximately \$22,000, although most of the apparatus which had been installed in the old laboratory has been moved in, so that the total value of apparatus and equipment in the new building would considerably exceed the \$22,000 mentioned above.

New Laboratory

The building about to be described contains the laboratory for steam and gas engines, steam boilers, refrigerating machinery, belt and ad testing, and other similar work, and also that for hydraulic work of various kinds. It is built of white brick with white stone trimmings

and consists of two parts divided by a wall running east and west, the part to the south of this wall having but one floor, while the part to the north has three floors.

When the building was first under consideration a number of very difficult problems presented themselves, partly in the way of finding sufficient room in already overcrowded grounds, and partly in the way of making the building harmonize with the other University buildings. In order to carry on the instruction required, a boiler room was necessary, which had to be placed on the outside of the building in order to facilitate the delivery of coal and the removal of ashes. Then, too, there was the problem of stacks, two of which have been provided for experimental purposes and the necessity of good light and large rooms, so that it was difficult to make the building look attractive. The architects considered the question with great care and arranged a scheme by which the boiler room and other unattractive parts will be eventually hidden when the entire group of buildings for the Faculty of Applied Science is completed.

The view on this page shows the building as it will finally appear. The front will be to the west and it will face on the main University road which runs north from College St., directly opposite University College. To the north of the build-

ing it is proposed in future to run a cross road east from the one above mentioned, the new road separating the Mechanical Laboratories and the building which will in time replace the present

block quite in keeping with the nature of the work being done by this Faculty of the University.

Owing to the other pressing needs it was felt by the Board of Governors that it would be impossible to erect the entire building at the present time and as laboratory accommodation had to be provided the part containing this was erected and a reasonable number of class rooms provided in it, while the front part, which will contain more rooms of this nature, has had to be omitted for the present.

The Thermodynamic Laboratory

Beginning with the space devoted to the heat engines and general mechanical work, we enter the Thermodynamic Laboratory. This laboratory occupies with the boiler room, the whole south half of the building and exclusive of the latter is 156 feet long by 60 feet wide with roof light throughout, there being no windows in any of the walls. It is divided into two parts, one being 40 ft. wide and the other 20 ft. wide, running the entire length of the room. The wider part has a clear height of 23 feet at the sides, being considerably higher in the centre. The narrower part has a clear height of 12 feet, and is divided up into smaller parts, there being eight small rooms, to be described later, and a space for delivery and unpacking of goods. The light is obtained from the roof and is as near perfect as can be expected. The ventilation is also very good being obtained by opening windows in the roof, a method which works so well that the building can be kept quite cool even with all the machines operating at once.

Internal Combustion Engines.—The equipment in the two parts of this laboratory may now be described in some detail, beginning with that in the larger part. The west end of this has been devoted to gas, oil, and other internal combustion engines and the equipment consists of a 10 h.p. engine built by Fielding

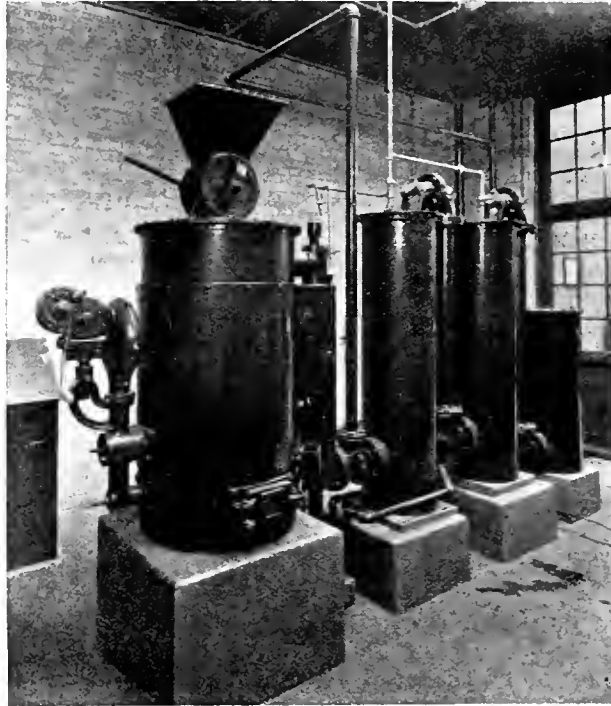

THERMODYNAMIC LABORATORY—SUCTION GAS PRODUCER PLANT.

Engineering Building. At present there is only a very narrow passage between the two buildings. On the south the building will be connected to the future extensions to the Chemistry and Mining Building, which extensions are to be so planned that almost the entire south side together with the boiler room, which is now exposed, will be hidden.

The building will thus have a fine appearance and will with the Chemistry and Mining Building form a fine, large

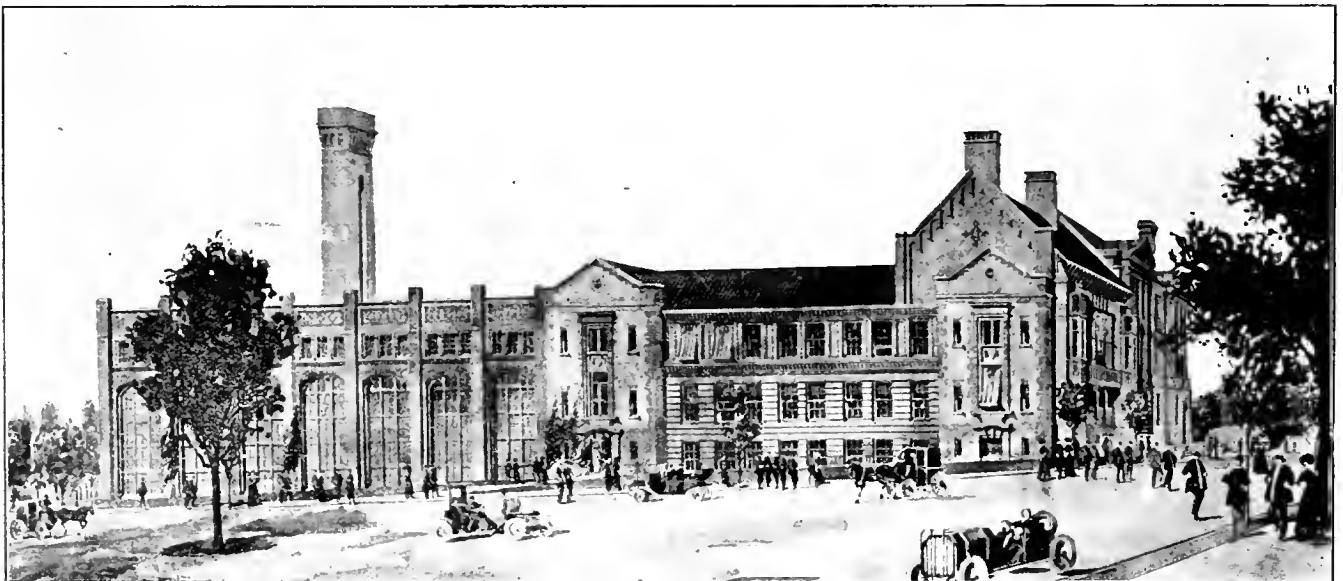

NEW LABORATORY OF FACULTY OF APPLIED SCIENCE CONTAINING STEAM, GAS AND HYDRAULIC EQUIPMENT.

& Platt, of Gloucester, England. This engine has a cylinder 7 in. in diameter and 14 in. stroke and has been specially built for experimental work. It is designed for variable compression, so that it may be adapted for use with different classes of fuels; and it is further equip-

which the gas is delivered to a pipe conveying it directly to the engine. It is arranged so that fuel consumption tests may be made with it and the action of the producer carefully and accurately studied.

Adjacent to the Fielding & Platt en-

interest. It is one of the slide valve type of engines with the old form of gas flame igniter, and is in good condition for test and comparison with the newer machines.

The space immediately in front of the engines just mentioned is used for two smaller test floors for gasoline and other similar small engines. Each floor is three feet square and has adjustable slots by which any small engine may be accommodated.

A marine gasoline engine with a cylinder 6 in. diameter and 6 in. stroke has been given by the Canadian Fairbanks Co., Toronto, at a nominal price and has been placed on one of the test floors mentioned and set up for experiments. This engine is to be equipped with an optical indicator made by Dobbie, McInnes & Co., Glasgow, so that its action may be accurately studied.

On the south side of the large room is an Eriesson air engine which serves to illustrate the action of this type of engine and give figures on its economy. It is arranged to be run by city gas and a brake has been arranged to measure the brake horse-power at the same time as the indicator diagrams are taken. The efficiency of the machine as a pumping engine may also be found by allowing it to lift a measured quantity of water against a measured head.

Other Apparatus.—Proceeding farther east along the large room there is seen a fan on which experiments on its efficiency are to be made.

A little farther down is a slide valve model. This model is very complete, and has been constructed so as to give results on almost any design of simple slide valve or link motion. The length of connecting rod is adjustable, as well as the angle of advance and throw of all eccentrics, the length of eccentric rods, radius and point of support and suspension of the link, etc.

There is also a journal oil tester built by Richle Bros. of Philadelphia, and having various adjustments. The journal used in the machine is a full-sized railway car journal, and the design is such

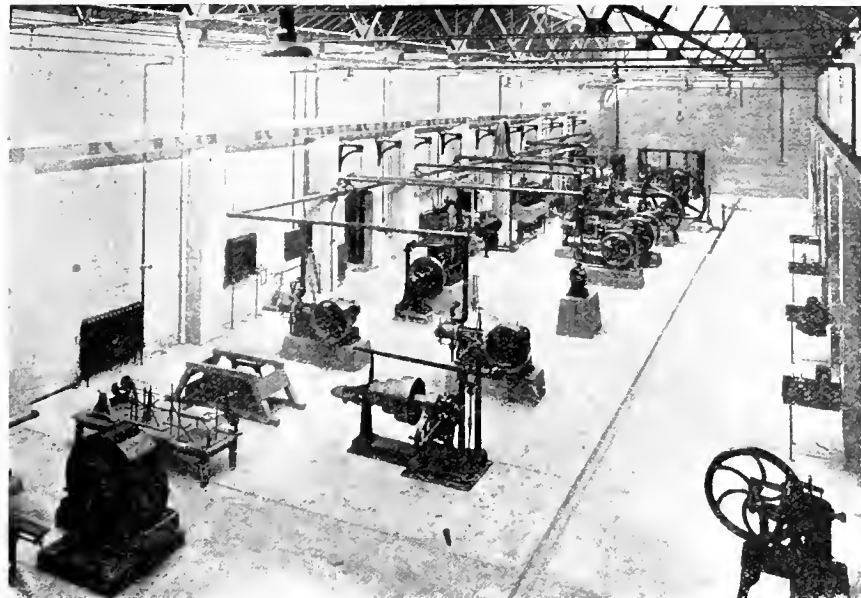

THERMODYNAMIC LABORATORY. GENERAL VIEW FROM WEST END

ped with three types of igniting gear, viz.: hot tube, high tension electric and a magneto gear, an arrangement being made so that the point of ignition may be varied at will while the machine is running. There is also a convenient method of varying the speed, and the use of heavy fly-wheels prevents great speed fluctuations at different speeds and loads. The engine is also fitted with vaporizing apparatus so that it may be run with oil, and has properly designed valves for the use of suction gas.

Adjacent to this engine is a larger one built by the National Gas Engine Co., Ashton-under-Lyne, England. It has a cylinder diameter of 9 in. and runs at a normal speed of 200 revolutions per minute, giving 22 h.p. on city gas. This machine is a very fine sample of a gas engine, being exceptionally heavy and having two massive fly-wheels which give steady speed. It has variable compression as in the case of the Fielding & Platt engine, and is designed for the use of either city or suction gas. It has only the magneto form of igniter, but the point of ignition may be altered without stopping the engine, which is noiseless in operation.

As already explained, both the above engines may be operated by city or suction producer gas. In the former case the gas is drawn directly through a meter where it is measured. When the suction gas is used the latter is drawn from a producer in the small room in the south-west corner of the building. This producer, which was built by the Canada Foundry Co., of Toronto, consists of a generator complete with vaporizer, two scrubbers, and an expansion box from

engine and on the north side of it a test floor has been arranged so that engines of fairly large size may be conveniently tested, and it is hoped that various firms will, from time to time, place some of their engines at the disposal of the laboratory for examination and research work, as it is believed that this will prove of mutual benefit to the manufacturer and the University. This test floor is at present occupied by one of the earliest types of gas engines built by the Otto Gas Engine Co., Philadelphia. The engine has given good service in the engineering building for nearly twenty years and is retained to give some idea of the development of the gas engine of late years and because of its historical

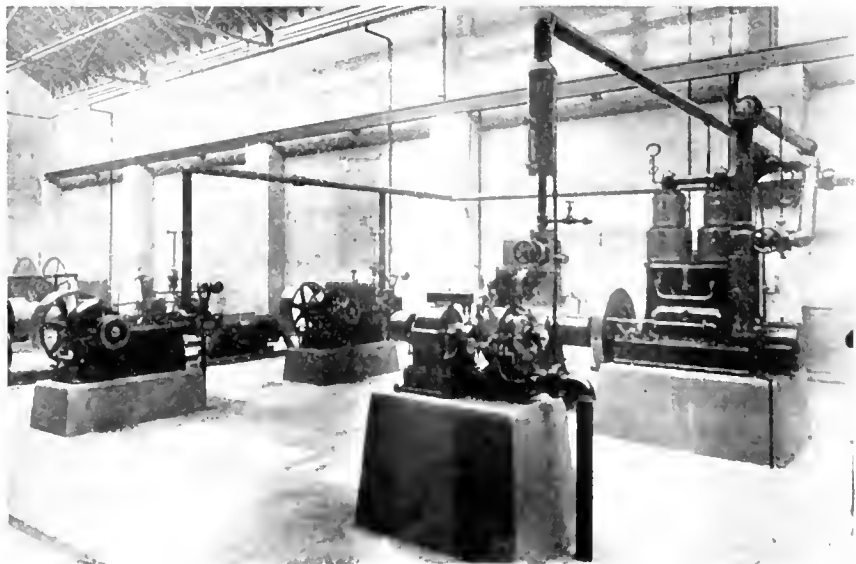

THERMODYNAMIC LABORATORY. THE LAVAL STEAM TURBINE WITH WILLIAMS VERTICAL AND LEONARD HORIZONTAL ENGINES IN BACKGROUND

that the actual pressures and speeds occurring in practice may, within limits, be obtained. The friction of the journal is conveniently read off on a scale beam.

The Steam Engines.—We pass on now to the steam engines. The first of these are two of comparatively small size which were presented to the Laboratory

ing at this speed 75 h.p. with a steam pressure of 125 pounds per square inch.

The design is rather peculiar, as there is no valve gear evident externally. The piston rods are hollow and the piston valves are operated by eccentrics forged solid to the crank pin. In this particular engine there are two high pressure and

A passage leading to the door separates these engines from the McEwen high-speed horizontal engine. The cylinder is 8 in. diameter and 7 in. stroke, giving 18 h.p. This engine has a good form of shaft governor, so that it is well adapted to instruction in the use and action of such governors, as well as providing good indicator practice. As it is connected like the other machines to the surface condenser, tests on the economy of the machine may be conveniently made.

The Leonard-Ball tandem compound engine is also provided with a shaft governor of different type from the one mentioned above. This engine is horizontal and has cylinders 7 in. and 12 in. diameter by 10 in. stroke, and will thus develop about 29 h.p. at 250 revolutions per minute.

There are two types of valves in the engine, the one in the high-pressure cylinder being a Ball valve with double inside admission. The valve is partly balanced, gives rapid cut-off, and on account of the double parts has a comparatively small travel. In the low pressure cylinder a balanced D slide valve is used.

This engine provides instruction in the tandem type of machine as well as practice with a shaft governor.

Next to the engine just described is the air compressor, a machine built by the Canadian Raud Drill Co., Sherbrooke, Quebec, and purchased through Mr. Haight of the class of '96 at one-half the actual commercial selling price. This machine is of the cross-compound, steam-driven, two-stage type, having the low pressure air cylinder arranged tandem with and behind the low pressure steam cylinder, and the high pressure steam cylinder in front of the high pressure air cylinder. The steam cylinders are respectively 9 in. and 16 in. diameter, while the air cylinders are 9 in. and 14 in. diameter, all having the same stroke of 12 in.; the normal speed is 160 revolutions per minute and the rated capacity 340 cu. ft. of free air per minute,

by Messrs. E. Leonard & Sons, London, Ont. These engines are used almost exclusively for exercises in valve setting, and have cylinders 6 in. and 7 in. in diameter respectively, and 8 in. stroke, but have different types of slide valves. The one to the south has the ordinary D form of valve and a special design of eccentric may be independently varied. The other engine has a special type of inside admission valve, which is partially balanced and so designed that the engine may be operated without the steam chest cover and thus show the motion of the valves; this engine has an eccentric of the same type as the one just described.

Both of these engines are fitted with throttling governors and suit the work for which they are designed exceptionally well, the kindness of the donors being much appreciated.

Next to these is a 15 h.p. de Laval steam turbine, built by Greenwood & Batley, Leeds, England. As is the case with most of the other machines, this turbine has been specially arranged for experimental work and has six nozzles altogether, some of which are for non-condensing operation and the others are used when running condensing. The rotor of this turbine runs at a speed of about 24,000 revolutions per minute, the power shaft running at one-tenth of this speed. This turbine has been found very useful as an experimental machine.

Behind the turbine is a Willans vertical, high-speed compound engine. This machine was purchased to drive the turbine pump in the old laboratory, but with the building of the new one an extra pump had to be installed so that a larger engine had to be purchased to supply the necessary power and the Willans engine became available for experimental work. It is of the high-speed type, having a normal speed of about 460 revolutions per minute, and develop-

two low pressure cylinders, the high pressure cylinders being above the corresponding low pressure ones; all are single-acting, and in order to prevent shock on the crank at the end of the stroke there is an air piston below each pair of cylinders, the pressure of the air compressed by it being sufficient to make a continual downward thrust. The crank bearings have no upper cap and require none for the above reason.

The steam cylinders are respectively 10 in. diameter and 14 in. diameter, and all pistons have a stroke of 6 in.

Engines of this type have met with great favor in England because of the low steam consumption, a paper by Mr. Willians read before the Institution of Civil Engineers in April, 1893, giving some very valuable information along this line.

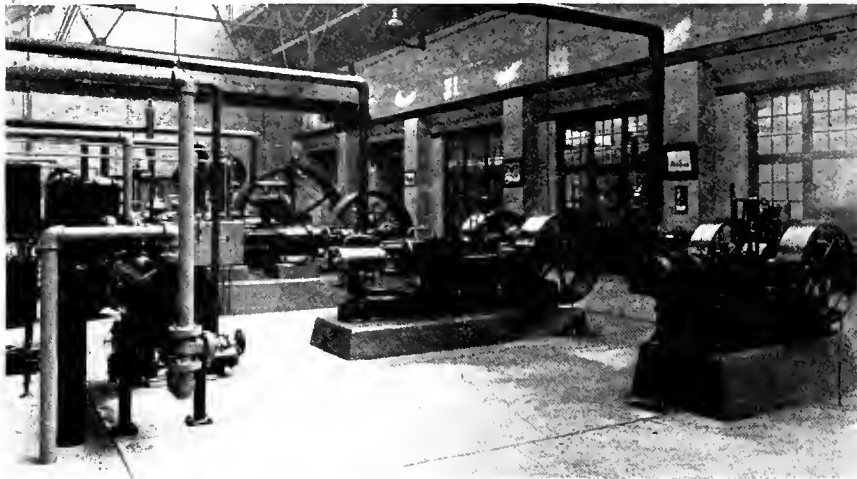

THERMODYNAMIC LABORATORY—McEWEN AND LEONARD-BALL ENGINES WITH CONDENSING PLANT AT LEFT.

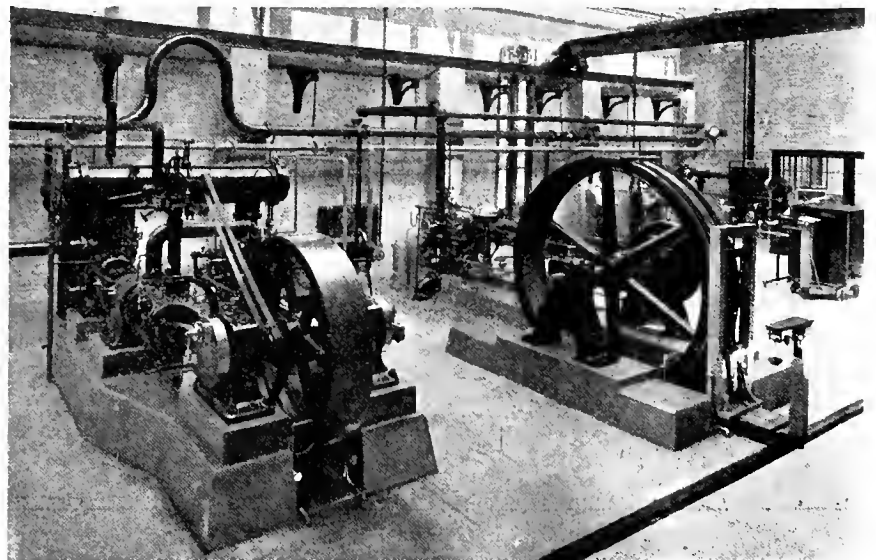

THERMODYNAMIC LABORATORY—CANADIAN RAUD AIR COMPRESSOR AND BROWN STEAM ENGINE.

with a steam pressure of 125 lbs. per sq. in.

The fly-wheel is arranged with inside flanges so that a brake may be applied to it, and by disconnecting the air cylinders the whole may be run as a cross

All connections on this line are flanged and each engine draws its supply from the top of the pipe, thus avoiding water from drainage and condensation.

All engines are arranged to run either condensing or non-condensing, two sur-

forms of the Prony brake, the wheels being generally provided with inside flanges so as to avoid annoyance from the cooling water.

The remainder of the space in this part contains a test floor, which permits any engine submitted for test to be easily set up and run either condensing or non-condensing. There is also a space for the testing of injectors, these being arranged in a convenient and neat pipe stand ready for operation.

At the end of the room is a Cochrane feed water heater purchased from the Canada Foundry Co., Toronto.

Some space has been left at this end of the room for expansion, and it is hoped that in the near future a triple expansion engine will be installed here.

Small Laboratory Rooms.—The narrower southerly portion of the Thermodynamic Laboratory (with the exception of the two end bays, which are used for delivery and unpacking) is divided into eight small rooms for special work of various kinds. The first two rooms are connected by a door, and are used as a small repair and instrument-making shop, in which special apparatus is made as required. This shop contains a new 20-in. Bertram engine lathe of modern construction built by John Bertram & Sons, Dundas, Ont. There is also a 20-in. McDougall drill, an emery wheel and a wood-turning lathe, together with a good equipment of tools. The shop is driven by a Westinghouse motor.

The third room will contain the apparatus for testing various machine elements and the methods of power transmission. For this purpose a tor-

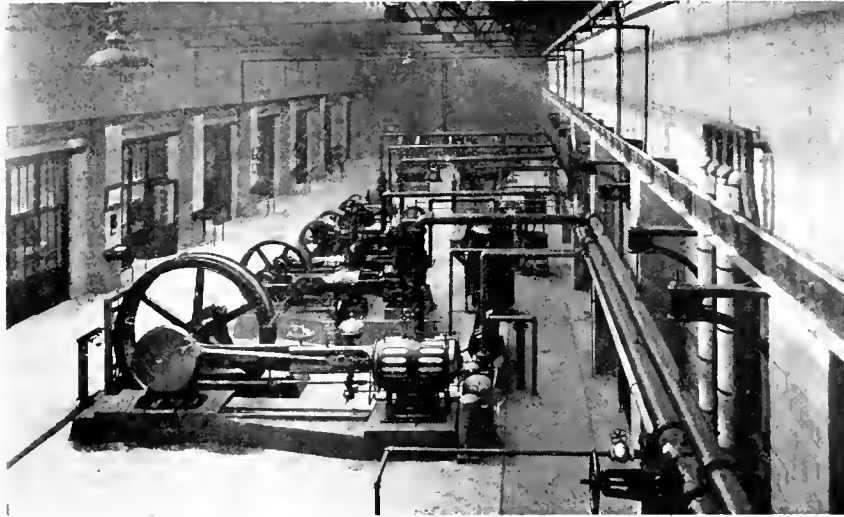

VIEW OF THERMODYNAMIC LABORATORY FROM EAST END

compound steam engine. Both steam cylinders are provided with Meyer cut-off gear, giving considerable elasticity.

The low pressure air cylinder has Corliss inlet gear and pressure gauges and thermometers are arranged for experiments of various kinds.

An air receiver is installed and piping runs to the mining building, delivering air when required to drive a rock drill.

This machine is of great value and usefulness and forms a very good piece of experimental apparatus.

When the engineering building was opened it contained a 50 h.p. Brown automatic cut-off engine built by the Polson Iron Works, Toronto, and this engine has been set up again in the new laboratory. It is of special design for experimental work and has jackets on both heads and on the barrel, all jacket drains being separate in order that the condensation in each part may be independently determined. The clearance volumes in this particular machine are also made specially small, and it runs quite economically.

The Steam and Exhaust Piping. An examination of the photographs will show the general arrangement of the steam piping. It consists of a single line of 5-in. pipe running through the boiler room and about 90 ft. along the wall of the Thermodynamic Laboratory, also of a 3½-in. pipe running from the northerly boiler up to the Brown engine connection. The latter pipe is designed so that it is possible to run a complete engine and boiler test on the Brown engine and the one 50 h.p. boiler. Connections are also made so that this boiler may deliver steam to the 5-in. pipe and the Brown engine may also be arranged to draw from the same pipe.

The 5-in. pipe has two large expansion bends, the one near the Brown engine being distinctly visible in the photographs

face condensers with independent air pumps being installed for the former condition of operation. There are two 6 in. exhaust pipes, one of which is connected to the condensers, the other through the heater to the atmosphere. Both of these are arranged with flanged connections and the system is so designed that by the removal of a few bolts any engine may be changed from the atmospheric exhaust to the condenser in a very short time, it being only necessary to change one blank flange and turn an elbow through 180 deg. The operation is thus accomplished without the use of valves and the measurement of the condensed steam becomes at once accurate. The system also permits the running of almost any pair of engines condensing, and at the same time the operation of all the other engines non-condensing. Proper drainage is provided for all piping, and it has all given perfect satisfaction up to the present time.

The cooling water piping is shown below the steam piping, but possesses no special features.

Brakes. The writer believes that brakes should be of the simplest form possible so that students get accustomed to the handling of the cheapest and most accessible types. The brakes used are, therefore, rope brakes or else simple

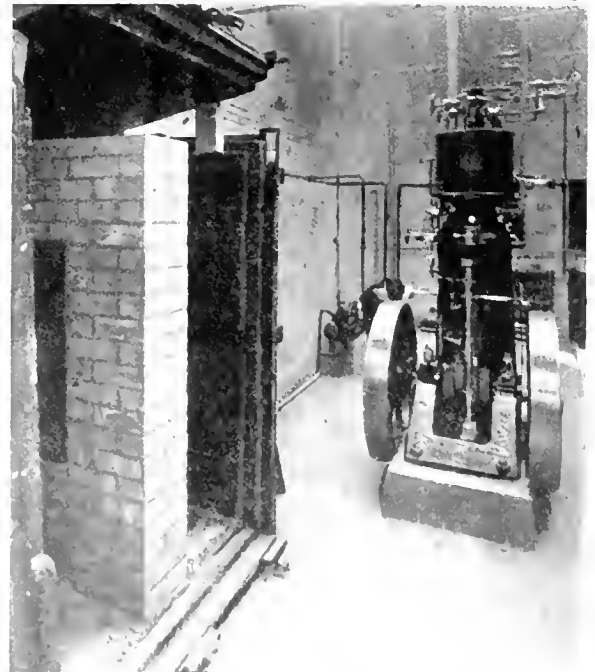

Thermodynamic Laboratory Refrigerating Plant with Test Chamber for Building Materials on Left

transmission dynamometer has been purchased from J. Amstler-Laffon & Sohn, Schaffhausen, Switzerland, which may be used for the transmission of any power not requiring over 540 ft. lbs. twisting moment. As the machine may be safely run

at high speeds its possibilities in the way of power transmission are fairly great, and it thus serves as a very flexible instrument. This instrument will be used to deliver a measured quantity of power to a belt or rope or any form of bearing or machine element, and the efficiency

The whole of the larger part of this laboratory is served by a three-ton travelling crane of about forty feet span. This crane is operated by hand, and has proved of inestimable value in the placing and handling of the different pieces of apparatus.

of special construction for experimental work. This pump was designed along theoretical lines, and has carefully polished vanes on the runner; it is mounted on a weir tank so that the discharge may be very easily measured, the various heads under which it is operated being obtained by throttling. The pump is driven by a variable speed motor, by means of which the power put into the pump may be determined and its efficiency readily obtained. The arrangement has been found very satisfactory, as it gives the student an opportunity to study the effect of variations in speed, discharge, pressure and efficiency of the machine.

Adjacent to this are two orifice tanks and a weir tank used mainly for instruction in the use of orifices and weirs. Various sizes and shapes of orifices are inserted and operated under several heads as measured by hook gauge. The water is discharged through 6-in. pipes into the calibrating tanks below, of which there are six, two for each orifice and weir, each tank having a capacity of about 50 cu. ft.

These calibrating tanks are of some interest, and have been carefully designed so as to be entirely operated by the movement of a single lever. When the lever is put in one extreme position, one tank is made to fill, its outlet valve being closed, while the outlet valve of the other tank is at the same time open. For the small discharges the tank fills so slowly that the upper surface is quite smooth and undisturbed, and, therefore, the exact height of the water in the tank, and consequently the volume of the water at the moment of dumping is easily ob-



HYDRAULIC LABORATORY ESCHER, WYSS AND GWYNNE PUMPS DRIVEN BY BELLIS & MORCOM ENGINE.

of the transmission or element may be directly determined by absorbing the power by a brake at the driven end.

The fourth room contains a refrigerating machine of three tons capacity, built by the York Manufacturing Co. of York, Pa. It is of the ammonia compression type and the horizontal steam engine and vertical compression machine are connected to the same crank. The complete accessory equipment has been provided and arrangements made for indicating the steam and ammonia cylinders and for taking the temperature at every desirable point in the plant.

The next room has been set apart for instruments, and in it are kept all of those used in both the Thermodynamic and Hydraulic Laboratories. All instruments are given out to students on application by ticket and are charged up against the one receiving them. When an instrument is returned it is examined and if in proper condition is put in its place, but if found to have been damaged by the student, the cost of repair is charged against him. By this system careless handling or loss of instruments is avoided.

The sixth room is used as a third year study room, while the seventh is to be used for the testing of lubricating oils and the determination of the heating power of gases and fuels of various types. A Sargeant gas calorimeter has been purchased and is to be used in this room.

The last room is occupied by the suction gas plant, described earlier in this article.

Just in front of these rooms and secured to the crane piers a number of tables have been placed, on which work on gauge and indicator calibration may be carried out, the gauge calibration being done by Crosby gauge testers, while the indicator springs are calibrated by means of steam supplied at various pressures.

The Hydraulic Laboratory

The Hydraulic Laboratory occupies the north half of the building, and is located in the basement and ground floors, each of which is 40 ft. wide by 113 ft. long. The light for this laboratory had to be obtained from the north and east, and as only one large window could be placed in the east end, the north light had to be depended on almost entirely. Large windows running up the full height of the two laboratory storeys were designed, which take up three-quarters of the entire side of the building. This gives a good architectural effect, and while not giving as good light as is obtained from the roof in the Thermodynamic Laboratory, yet it is quite satisfactory.

On account of the large area of glass exposed to the north, trouble was anticipated in the way of heating the building, and arrangements were made to put double windows throughout, which, however, have not been necessary.

The lower storey or basement is 18 ft. high, and contains the well, the pumps and the engine for driving them, the measuring tanks used for calibrating the orifices and weirs above, several large troughs and the main part of the piping for the entire laboratory, while the upper floor, which is 15 ft. high, contains the orifice and weir tanks, the experimental centrifugal pump with its weir tank and motor, the various pipes for friction experiments, the meters, and also the various types of turbines and other apparatus.

Beginning with the top floor at the west end, part of the space had to be left clear for a hoist hole, the first piece of apparatus being a centrifugal pump

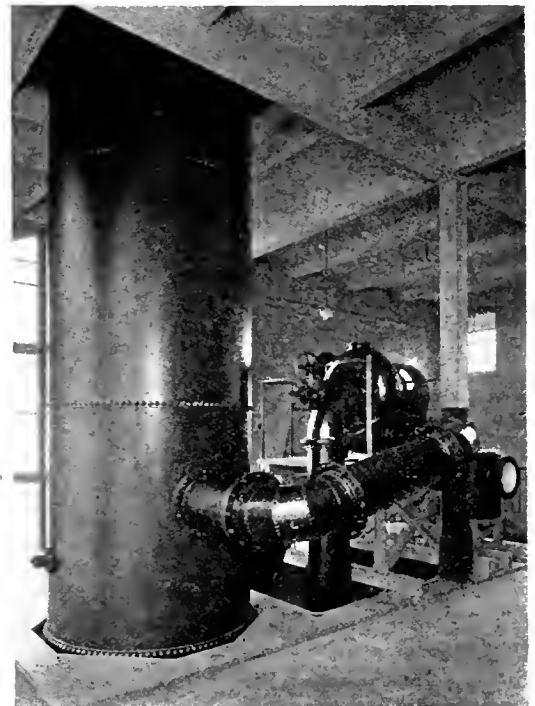

HYDRAULIC LABORATORY, FRANCIS HORIZONTAL TURBINE COUPLED UP TO 5 FT. 6 IN. STANDPIPE.

served, but where the discharges are large, the surface of the water in the calibrating tank is so disturbed that accurate observations of this kind are im-

possible. To obviate this trouble the mechanism is so designed that by moving the lever to an intermediate position the outlet valve on the other tank is closed, and the discharge turned into it, the water surface in the first tank coming to rest at once its height is easily observed, after which the lever is pushed to the other extreme position, the outlet valve of the first tank being thus opened without disturbing the conditions in the second tank.

The quantity of water in the tank after filling may be found by direct weighing or by reading the level in an attached gauge glass.

The floor has been constructed with an opening protected by a rail, so that the student may observe the whole operation at one time and thus get a clear idea of the process of calibration.

In order that experiments on these tanks and orifices may be carried on without interfering with the other work, a large reservoir, provided with an overflow, has been placed above them, and from this they draw water. So long as there is enough water passing into the reservoir to cause some overflow the experiments may be carried on at various heads and discharges without difficulty.

From this reservoir a 1¼-inch pipe is also run to a hydraulic ram which can thus be operated under a head of about 10 ft. and with a drive pipe about 40 ft. long.

A three-inch Venturi meter has been installed on a pipe in which other meters will also be placed. This meter is rated by sending the discharge from it through one of the orifice tanks already described, using the coefficients determined by actual experiment.

A little to the east of the centre of the laboratory an elevated platform about 25 ft. long and 7 ft. wide has been erected for the impulse turbines. At present two turbines are in use, one a Doble wheel made by the John McDougall Caledonian Iron Works, Montreal. This is a very well finished wheel of 12 in. dia., and as it has glass sides the action of the water may be very conveniently studied. The needle regulating nozzle gives a very perfect stream.

The other machine is an 18-in. wheel made by the Pelton Water Wheel Co., and although not so well constructed, it represents a very common class of water-wheels in use to-day.

The water used by these turbines is measured by passing it through a weir tank and then back to the pump well. For the use of these turbines it is possible to get a discharge of 1 cu. ft. per sec. against a maximum head of about 500 ft.

At the east end of the room is a large stand-pipe 32 ft. high and 5½ ft. dia., supported on a stand in the basement so that it reaches up into the roof of the building. This stand-pipe is used as a reservoir for the reaction turbines and also for any experiments requiring constant but not very high heads. This stand-pipe has a 14-in. nozzle on each side for the attachment of turbines and also a large nozzle 30 in. dia. on the front

so arranged that orifice plates and tubes of various sizes may be attached and experiments made at higher heads than is possible in the open orifice tank. The water is delivered to the stand-pipe through two 8-in. pipes near the bottom and by a convenient arrangement of baffle plates there is no trouble caused by the surging or eddying of the water.

In front of this stand-pipe is a large weir tank 20 ft. long by 6 ft. wide, which is arranged with a sharp crested weir 4½ ft. wide with end contractions. This plate may, however, be changed so that weirs of different sizes, with or without end contractions, may be easily inserted. The total depth of the tank is 3 ft. 9 in. and the depth of water below the crest of the weir is 2 ft. 3 in.

The weirs used in this tank may also be calibrated by means of a pair of measuring tanks in the basement, each holding approximately 240 cu. ft. and

This 6-in. turbine has been operated under a total head of over 25 ft. including about 5 ft. in the draft tube. The horse-power is measured by Prony brake and the discharge is determined from the 4½ ft. weir.

A 9-in. McCormick turbine with cylinder gate has not been set up but is left to give the student practice in the measurement of such wheels and to enable him to study the forms of the vanes.

The latest turbine to be installed is one purchased recently from the noted hydraulic firm of Escher, Wyss & Co., Zurich, Switzerland. This wheel, of the horizontal Francis type, has a well designed spiral casing and a runner nearly 14 in. dia. The gates are of standard design, operated through a ring by a hand wheel on the casing. A conical draft tube over 7 ft. long is used and the wheel will deliver 10 H.P. when supplied with 6 cu. ft. of water per sec. at

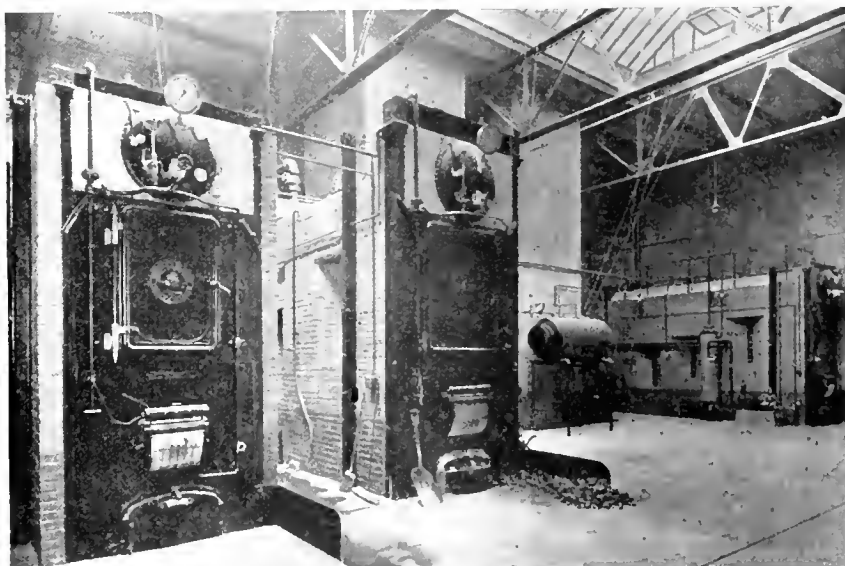

BOILER ROOM ONE 100 H.P. AND TWO 50 H.P. BARBOCK & WILCOX WATER TUBE BOILERS.

both being connected to the weir tank on the down stream side of the weir by 12-in. galvanized iron pipes. Hydraulically operated valves are to be used in connection with these calibrating tanks and are so designed that a single lever is made to do the whole operation of filling emptying as in the case of the smaller tanks already described. This lever, as in the former case, has three positions when operating, the extreme positions indicating that one tank is filling and the other emptying, while the intermediate position is used when both discharge valves from the tanks are closed and one of the tanks is filling. It is believed that very accurate coefficients can be determined by this method.

There are three reaction turbines available for testing. The smallest one has a 6-in. runner and was made by Wm. Kennedy & Sons, Owen Sound, Ont. It has been set up in a steel penstock and connected to the stand-pipe by a 14-in. steel pipe containing two elbows. This pipe is to be used for experiments on the flow through elbows, the conditions being examined by a Pitot tube.

a head of 20 ft. As this wheel is of the very best construction it forms an excellent addition to the experimental equipment.

The maximum quantity of water available for these reaction wheels is about 6 cu. ft. per sec.

Along the north side of this floor near the windows arrangements are made for the testing of the friction in fire hose and iron pipe. A 2½ in. iron pipe 50 ft. long has been set up, also a 50 ft. length of fire hose, and the frictional losses are determined. The flow in the iron pipe is also studied by the Pitot tube, and curves showing the distribution of the velocity are plotted.

The basement contains, in addition to the orifice and weir calibrating tanks already mentioned, the well and pumping plant. All water used in the laboratory is drained back to a large well from which it is pumped into the system and used over and over again.

There are two sets of turbine pumps used for this purpose, one of which was built by Messrs. Gwynne, London, England, and the other by Escher, Wyss &

Co., Zurich. Each set consists of two two-stage pumps fastened to a common bed plate and driven by a single pulley, couplings being arranged so that either pump may be separately operated. Further, the two pumps on the one base are piped together in such a way that they may be made to deliver into the piping in three ways, viz., (a) separately, (b) in series, (c) in parallel. A connection is also designed to connect the discharge from the Gwynne pump to the suction from the Escher-Wyss pump, putting the two sets in series for very high pressure work.

Each of the Gwynne pumps will deliver 1 cu. ft. per sec. against 125 ft. head, while the other pumps have the same capacity against 150 ft. head, the discharge at lower heads being, of course, much greater.

As suitable piping has been arranged in the laboratory, it may thus be seen that the whole arrangement of the plant is very flexible, permitting (a) the operation of the four pumps separately, thus allowing four absolutely independent experiments at one time; (b) the operation of the two sets separately on separate experiments; (c) the operation of the two sets in series for high pressures and moderate discharges as are required in fire streams and impulse turbines, giving 1 cu. ft. per sec. at 500 ft. head; (d) the operation of the two sets in parallel giving about 6 cu. ft. per sec. at the heads available in reaction turbine work in the laboratory.

The pumps are of modern design, the Escher-Wyss set having been installed quite recently. They run at speeds of 1,300 and 1,400 revs. per min. respectively, and are belt-driven from a jack shaft placed on the floor, vibration of the building being thus entirely avoided. The jack shaft is driven by a Belliss Morcom engine of 130 H.P. running at 530 revs. per min. This engine is a very fine piece of workmanship and runs quietly and without vibration. The exhaust from the engine is used to heat the building.

Arrangements are being made for the insertion of a transmission dynamometer in the Escher-Wyss pump drive so that its efficiency may be determined with greater accuracy than can be obtained by indicating the engine.

A large trough 6 ft. wide, 4 ft. deep and 110 ft. long has been provided in the basement which is used for the rating of current meters and tubes and other work of this nature. It is believed that this will be especially useful in view of the rapid power development going on in Canada at the present time.

There is sufficient space still left for further expansion.

The Boiler Room

This room contains three Babcock and Wilcox boilers, all built for 200 lbs. pressure.

The 100 H.P. boiler is provided with a superheater while the two 50 H.P. boiler have been set up independently and one is arranged with a special type of

setting so that valuable comparative results may be obtained.

A separate feed pump is provided for each boiler so that separate tests may be made on each one.

A steel breeching conducts the products of combustion to the stacks, of which there are two of brick, each 100 ft. high and 36 in. internal diameter. An arrangement of dampers allows these stacks to be operated at different powers on the same day and thus reliable experiments may be made on the capacity of each stack.

The room is light and airy, being 70 ft. long, 45 ft. wide and 26 ft. clear height. All the light is obtained from the roof and is very satisfactory indeed.

Offices and Study Rooms

AT the north-west corner of the building, immediately west of the Hydraulic Laboratory, there is a further space partly occupied by the stairways and halls and partly by other rooms. These rooms are as follows: In the basement the students' room with shower bath, on the first floor the professor's and the lecturers' rooms while the top floor is occupied by a lecture room and private lavatory.

An entire floor above the Hydraulic Laboratory is divided up into students' study rooms, a lecture room, a library, demonstrators' rooms, and students' lavatory. All of these rooms are comfortable and bright and the students' rooms are provided with convenient tables and a locked drawer for each person.

Artificial Lighting

The large Thermodynamic Laboratory is lighted by ten Nernst lamps, which are attached to the trusses and provide sufficiently good light to do any work required. The Hydraulic Laboratory is lighted by tungsten lamps, there being ten to each floor.

The remainder of the building, with the exception of the boiler room, which also has a Nernst lamp as well as incandescent lamps, is lighted entirely by incandescent lamps, which seem to give very good satisfaction so far.

Conclusion

This article would be incomplete without making mention of the work of Dean Galbraith. It was he who gave the writer his first real insight into the profession which he honors and it is on the foundation laid by him that the writer has built in striving to design a laboratory that shall give the future engineers the proper basic principles on which their life work depends. The teaching of principles is vastly more important than the teaching of a few facts, the desire to teach these principles in such a way as to make the practical application clear is a thing for which Dean Galbraith has always stood, and the writer's association with him and the engineering world have given him the desire to make the laboratories described such as shall be a real help to the student when he gets into active practice.

Acknowledgment is also made of the help given by the members of the staff in Thermodynamics and Hydraulics who assisted by many suggestions and by the sacrifice of much time in making the building and equipment such as it is.

It will be noticed that all of the units in the two laboratories are comparatively small and are such as can be handled with comparative ease. The writer believes this to be a valuable feature of such a laboratory, as the student can readily comprehend the whole machine at one time, and therefore does not lose the connection between the different observations as he is apt to do with the larger units where the parts are so much separated. The results obtained are, the writer believes, quite as valuable, from the point of view of the instruction to the student when obtained from reasonably small machines as from very large ones.

No machine in the laboratory is used for electric power or for any other than experimental purposes, so that all pieces of apparatus are always available for experiment or research.



OBTAINING DRAUGHT WITHOUT HIGH CHIMNEYS

IN ordinary practice, the use of the chimney is to cause a draught to make the fire burn, or in other words to cause the passage of a sufficient volume of air at a moderate velocity to supply oxygen enough to enable the fuel to be consumed to the greatest advantage, and incidentally to carry off the burnt (and unburnt) products arising through the combustion of the fuel. So far as it goes this is all right; but in very many cases it leaves much to be desired. To secure the most efficient heating it is necessary that the fuel should be reduced to its highest gaseous state—in the case of carbon this would in ordinary cases be carbonic acid—and to get to this stage it is necessary that large volumes of air must be drawn through the fuel at a comparatively low velocity. This is best done by means of exhaust fans of fairly large size, the discharge from which is passed through stacks of brushwood not too tightly packed together and kept damp by some simple method of water distribution and spraying.

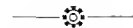

Invar is a nickel steel containing about 36 per cent. nickel, together with about 0.5 per cent. each of carbon and manganese. Its most remarkable property, says the *Iron and Steel Trades' Review*, is its extremely small thermal expansion at ordinary temperatures, owing to which quality it is now used for making steel tapes for precision measurements. Its mechanical properties are about as follows: Tensile strength, 50,000 to 85,000 lbs. per square inch; elongation, 40 to 50 per cent.; reduction of area, 40 to 65 per cent.; and Brinell hardness, 160.

EDITORIAL CORRESPONDENCE

Embracing the Further Discussion of Previously Published Articles, Inquiries for General Information, Observations and Suggestions—Your Co-operation is Invited

PRELIMINARIES IN MACHINE PART PRODUCTION METHODS—III.

By F. Seriber.

THE examples so far shown have been of operations performed on one machine only, and as the best way to become familiar

LIST OF TOOLS		
Name of Subject	Bracket No. 2197-D	
Date	Feb. 17, 1916 By St. St.	
Sketch of Subject 		
Material	Cast iron	
Machine	Miscellaneous	
No.	Operation	Tools Required
1	Bring casting	Band stone
2	Drill seat A	Horizontal milling mach and fixture locate from top
3	Straddle mill boss	Locate from seat previously milled and use horizontal machine
4	Drill & ream large hole, drill small hole, drill and countersink screw holes	Drill jig, locate from finished seat and sides of boss; Counterbore with steel collar
5	Burr	Bench
6	Drank	
7	Assemble	

FIG. 7.

with a system is to use it in its various forms, a part to be manufactured on various machines is illustrated by Fig. 7; the subject in this case is a bracket, No. 2197-D. The material is cast iron, and a sketch of the subject is shown under that heading; under machine, the word "Miscellaneous" is used as this aptly describes the machining operations on this part. As the various notes in the two columns describing the

operations of the tools tell the story, further reference in regard to this sheet is unnecessary.

For Miscellaneous Work

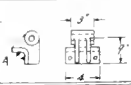
The next two illustrations, Figs. 8 and 9, show operation lists which vary slightly from the foregoing examples. In these lists a column is provided for the operation numbers at the left and a column for the tool number is at the right of the sheet. These lists of tools describe "Miscellaneous" machining operations, that in Fig. 8 being an ideal type on which the first operation is to disc grind the surfaces marked A on a disc grinder. Of course, no special tools are required for this operation. The second operation is to mill end B, and the third operation is to mill end C. A special fixture is required to perform these oper-

LIST OF TOOLS		
Name of Subject	Adjustable Carrier No. 229-Y	
Date	Jan. 22, 1916 By St. St.	
Sketch of Subject 		
Material	Machine steel	
Machine	Miscellaneous	
No.	Operation	Tools Required
1	Cut off stock	Track saw
2	Plane flat sides x	Planer
3	Bring mill screws A	Horizontal milling machine & gang cutters
4	Burr - with file	Gang on planer
5	Plane short end	
6	Burr - with file	Form cutter
7	Drill slot B	Fixture, locate from short end & angle A
8	Plane sides	Fixture, must hold bar on angle, locate from inside A. After the bar is cut, machine part on other side
9	Burr - with file	Cut as many as possible on special face plate, locate from inside A and end
10	Turn radius	
11	Burr - with file	Jig, locate from inside
12	Drill ream and countersink	
13	Drank	Bench
14	Inspect	
15	Assemble	

FIG. 9.

ations, and in the column headed "Tool No." it will be noticed the number of this fixture is 209. Of course, keeping these tool numbers straight means an extra job for the production man, but this is sometimes necessary when no other means of keeping records is available.

The list of tools, Fig. 9, is for an adjustable carrier, No. 889-Y, made from machine steel by miscellaneous operations. The operations on this part are quite numerous and varied, and require in all six special tools, which are numbered on the sheet.

Referring to Fig. 10, we note that the machine operations on the part there illustrated are: planing, milling, boring and drilling, and we next turn our attention to the bottom of the illustration and read the note, which says, "As but 112 of these parts are to be made, no

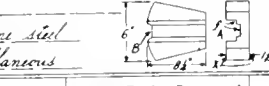
special tools can be allowed except where the word (make) appears." The operations on this list of tools are written in the usual manner, while the column headed "Tools Required" is used chiefly for descriptive purposes, emphasizing where the work is to be located.

LIST OF TOOLS	
Name of Subject	Worm Bracket No. 117-3-D
Date	Nov. 8, 1916 By St. St.
Sketch of Subject 	
Material	Iron casting
Machine	Drilling, Boring, Drill, Planer
Operation	Tools Required
Plane flat surface	Jack up as many as practical on planer
Straddle mill boss	Use standard angle iron and gang of straddle millings cutter on horizontal machine, clamp part against finished surface, rest on burr edge
Bore main hole	Horizontal grinding machine locate thru bearing block using lat
	Clamps to spot center of hole for hole
Drill & countersink holes	Steel template (make)
	Note—As but 112 of these parts are to be made, no special tools can be allowed, except where the word (make) appears.

FIG. 10.

Gang-Tool Operations

These lists of tools would be incomplete if at least one illustration was not included showing operations and fixtures for gang working some part. In Fig. 11, the sliding block, No. 21984, which is an iron casting machined by gang milling, is illustrated under the heading "Sketch of Subject." The operations on this part are two in number, namely, mill finished

LIST OF TOOLS		
Name of Subject	Outlet Pipe No. 105-Z-D	
Date	May 7, 1916 By St. St.	
Sketch of Subject 		
Material	Wrought iron	
Machine	Miscellaneous	
No.	Operation	Tools Required
1	Disc grays surfaces marked A	Disc grinder
2	Drill and F	Fixture locate from finisher pins & hole on center but fixture used on horizontal machine and must search for milling one end at a time
3	Drill end C	Drill jig on mylathe drill press locate from finisher surfaces
4	Drill seven holes to desired holes on all finished parts	
5	Burr	Bench
6	Assemble	

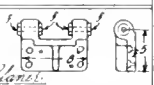
FIG. 8.

LIST OF TOOLS	
Name of Subject	Sliding Block No. 21984
Date	Nov. 7, 1916 By St. St.
Sketch of Subject 	
Material	Iron casting
Machine	Gang milling
Operation	Tools Required
Mill finished portions on 5 surfaces	Gang cutters 16 holes
	Fixture to hold 16 holes
Drill upper hole	Locate clamp
	Gang cutters
	Fixture before locate from finisher
	16 holes
	Clamp

FIG. 11.

portion on four-inch surface, and mill upper side. Sketches of tools required for performing these two operations are illustrated in the column provided for this purpose. These tools consist of a gang of cutters used on a horizontal milling machine and gang fixtures for milling four parts at each setting.

As stated at the outset of this article, these "Lists of Tools" are a plain statement of facts, and no attempt has been made to include or make these lists contain data for future reference, such as time records, etc., as the one object of these lists is to insure the economical routing of work by some one reputed to know how, and who will only make such special tools as will expedite work with the desired accuracy.

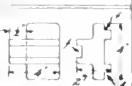

MACHINISTS' INSTRUCTION COURSE—XII.

By J. Davies.

THE principal operations in chuck and face plate work are boring and facing. The boring is done by some form of drill or boring tool, although a drill is not always necessary except in drilling from the solid. In drilling from the solid make a good-sized centre with the centering tool, to give the drill a chance to start true. A twist drill is best for drilling holes out of the solid. Never put a drill in the finished size of the hole at the first cut unless it is a very rough job, as the hole is almost certain to be untrue or too large, or both. The best and most accurate finish is done with a reamer; when it is intended to finish with a reamer, bore as large a hole as possible with a drill, while leaving sufficient stock to allow the hole to be trued up with a boring tool, and leaving about 1-64 in. for finishing with reamer. If the work is a

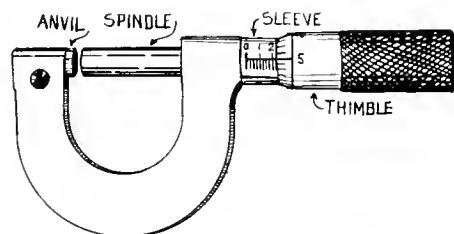

FIG. 48.

casting with a cored hole in it, an old-fashioned home-made flat drill is about the best thing to use preparatory to the boring tool; the sand in the cored hole would soon rub the clearance off a good twist drill, besides finally running out of truth. The flat drill should be fastened securely in the tool post where it practically becomes a boring tool; it also makes a very good substitute for a reamer and if made parallel for about 3/4 in. makes a smooth hole.

General Boring Work

The conditions under which a boring tool works are unfavorable for good re-

sults, as the diameter and length of hole to be bored impose unfavorable handicaps. The best results are obtained by using a round steel bar, fitted into a substantial holder which can grip the bar in any position, having the bar as nearly the full size of the hole as possible, and the cutting edge of the tool in the centre of the hole. If the tool is in-

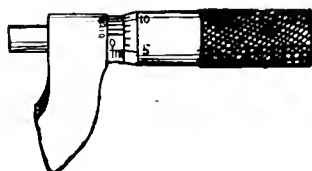

FIG. 49.

clined to chatter make the nose narrower and give the tool more side clearance. It is easier to prevent chattering than to take the chatter out afterwards.

Some jobs can be handled better by reversing the method of operation, that is, by fastening the work to the lathe carriage, and boring out with a tool in a bar that revolves between the centres of the lathe. This method is handy for heavy work, or work with very large holes to bore. A well-finished hole can be bored exactly to size, by having the cutter turned up in the boring bar to the required size.

Extremely heavy work such as large engine cylinders, are usually bored out, with a boring head carrying one or more tools, arranged to slide by power along the revolving boring bar. Various devices are employed to feed the boring head along the bar, the most usual being by means of a screw and star feed wheel.

Use of Micrometers

The most correct way to set inside calipers for boring small holes is from a pair of outside micrometers; set the micrometers to the size required, then set the inside calipers to just touch the anvil and spindle of the micrometers. The pitch of the screw threads on the spindle of the micrometer is usually 1-40 in., or 40 threads to the inch, therefore it would take 40 complete revolutions to open or close the micrometer 1 in. and one revolution will open or close the micrometer 1-40 in., or twenty-five one-thousandths of an inch. When the micrometer is closed the leveled edge of the thimble coincides with a zero mark on the sleeve and the zero mark on the thimble coincides with the horizontal line on the sleeve. Each complete revolution opens the micrometer 1-40 in. and vertical lines are placed on the sleeve 1-40 of an inch apart, each fourth line being made longer than the others and numbered 0, 1, 2, 3, 4, etc., so that each numbered line indicates 1-10 of an inch. The beveled edge of the thimble is divided into 25 equal divisions numbered from 0 to 25, so that when the thimble is moved from one line to another, the

spindle is moved in or out 1-25 of 1-40, or one-thousandth of an inch.

To read the micrometer, multiply the number of vertical divisions visible on the sleeve by 25 and add the number of divisions on the thimble from 0 to the line which coincides with the horizontal line on the sleeve. For example, the micrometer in Fig. 48 shows 9 divisions visible on the sleeve; multiply this by 25 equals 225, to this add the number of divisions shown on the thimble, which is 5. The micrometer, therefore, is open at 230 thousandths, or .230 in.

Reading the Vernier

Readings in ten-thousandths of an inch are obtained by an application of the Vernier, the invention of Pierre Vernier, this method of measurement being adaptable to any standard of measurement. As applied to a micrometer it consists of ten divisions on the sleeve which occupy the same space as nine divisions on the thimble and as each space on the thimble represents .001 in., each space on the sleeve will represent 9-10 of a thousandth, so that the difference between the lines will be 1-10 of one-thousandth of an inch.

To read a ten-thousandth micrometer, first note the thousandths in the ordinary way, then observe the line on the sleeve which coincides with a line on the thimble, the first line is marked and is the starting place; if the second line marked 1 coincides with a line on the thimble,

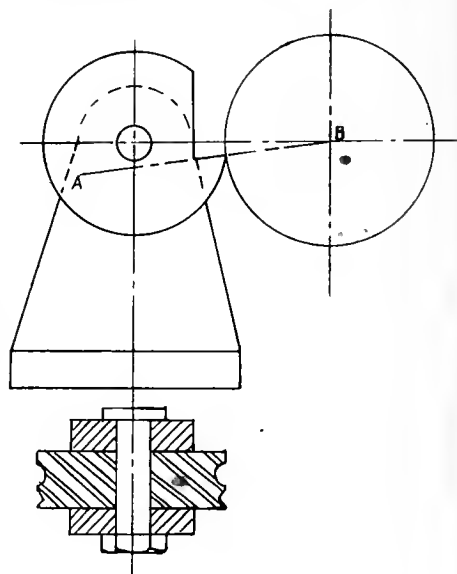

FIG. 50.

add one ten-thousandth; if the third line, marked 2, add two ten-thousandths and so on. See Fig. 49.

Types of Forming Tools

Many kinds of repetition work can be most economically done by forming tools, which are made in great variety, from the simplest radius tool, to very elaborate ones. The type and method of making depends largely on circumstances.

If there is not a very great quantity

of any one article, an ordinary lathe tool filed to a carefully made template will suffice. If the article being turned is made every day, then a more permanent forming tool can be made. A common form for an ordinary cross-slide lathe is the circular forming tool, consisting of a round piece of tool steel turned and formed so that when a section is taken at its cutting edge, it will be the shape of the work. A piece is cut out of one side of the cutter so that the edge AB is below the centre of the cutter Fig. 50.

The amount that the cutting edge is below the centre of the cutter varies with the diameter of the cutter, on a cutter 3 in. dia. about 5-16 in. being sufficient. The holder is made high enough to bring the cutting edge of the cutter opposite the centre of the work; if the tool is not set as described it will not have clearance and can only cut as long as it is absolutely sharp. Another kind of forming tool is straight-faced, being shaped or milled along the front edge to the desired form with a dovetail at back to fit some kind of block for holding it in position. They are set in the holder at a slight angle to give the proper cutting clearance, are very rigid, and can be ground a great number of times, retaining their original form as long as they last. Still another type suitable for broad surfaces is the draw out, the tool is not square across the cutting edge, but is made at an angle, so that when the tool is faced against the work, the full breadth of the tool is not cutting at the same time, one part of the tool having finished its work before the other part begins. Tools of this description have been frequently illustrated in connection with munitions manufacture and are almost exclusively used for turning the copper bands on shells.

USEFUL MILLING JIG

By W. G.

THE fixture described herewith shows a quick and cheap method of milling clearance angles on double-sided boring and facing tools; furthermore (assuming average care be used), it has the advantage of producing a far more accurate job than is the case by ordinary methods. A glance at the accompanying

tional elevation and plan views of the fixture.

The body A consists of a rectangular cast iron block of channel section, having at its extremes feet or projections, A¹ and A², for securing it to the ma-

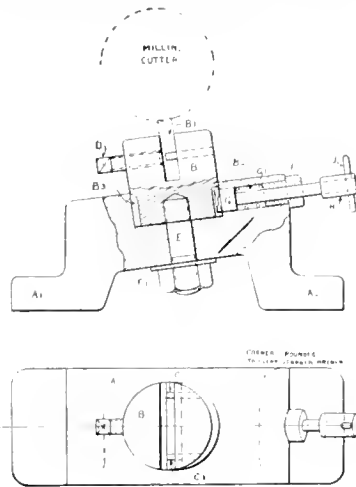

FIG. 2.

chine table. It will be noticed that the upper face of the said casting is provided with a circular recess set over at an angle; for all ordinary purposes this angle need for exceed 6 deg., as this governs the clearance on the tools. Part B is the work holder; this consists of a cir-

engaging the corresponding index slots, B² and B³. Part F is the retaining bush for the spring G'. It has been found from practice that a plain bush tightly driven into a hole is quite good enough for all ordinary purposes, as the only pressure it has to withstand is that of the index spring; and, further, being plain, the hole in the bush is more liable to be in proper alignment with that in the body than would have been the case had the bush been threaded. Parts H and J are the cap and "tommy" peg for index plunger.

The sequence of operations is as follows:—The work is placed between the locating pegs C and C' and clamped by means of the screw D. The side face of the milling cutter is set quite central with the work holder. The first cut is now taken over one side of work, the nut E' is released, and the index plunger withdrawn; a half turn of the work holder B brings the unmachined part of the work into position for its final operation, the result obtained being as shown by Fig. 1.

ADJUSTABLE RIVET SNAP

By E. T. S.

THE tool illustrated represents one of the many contrivances that lighten a job when an awkward corner is encountered. Every boiler has a firehole, and the rivets in the flanges are most

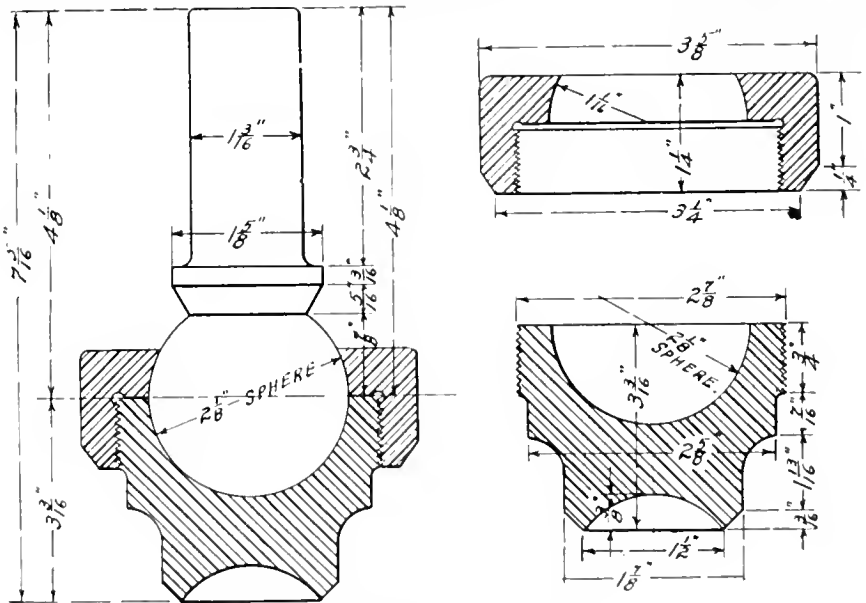

DETAILS OF ADJUSTABLE RIVET SNAP.

cular mild steel block, having a tapped hole at its lower end, the opposite end being provided with a rectangular slot B' for the purpose of receiving the work; it is also provided with two rectangular indexing slots, B² and B³. Parts C' C¹ and D are the locating pegs and clamp screw respectively. Part E is the clamp stud for holder; this should be made a tight fit for the tapped hole in the base of the work holder. Part E' is the clamp nut.

Indexing is carried out by means of the plunger G, the front end of which is provided with flats for the purpose of

awkward to rivet up on account of the small space wherein to hit direct. With this tool, the snap is set to the desired angle and tightened up, then the riveting is proceeded with in the regular manner, with the air hammer. The ball adjustment feature is a great advantage as it allows each man to set it according to his own height, and according to the position in which the boiler is placed. It is necessary to temper the shank end lightly to prevent swelling up, and of course the snap end is tempered as usual.

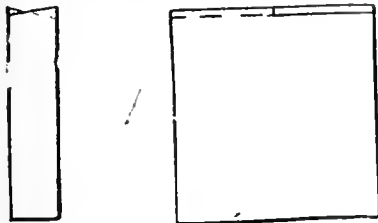

FIG. 1.

drawings will give a clear idea of its general construction. Fig. 1 shows work in finished stage. Fig. 2 shows part sec-

CANADIAN OIL PROSPECTS.

OIL possibilities in Canada are discussed in a statement just issued by the St. John, N.B., Board of Trade, which says:—

"New Brunswick possesses a valuable asset in its oil shales deposits. One of the best English authorities on oil, Sir Boverton Redwood, who made an exhaustive survey of this deposit, two years ago, reported that the New Brunswick shale was capable of producing thirty-three Imperial gallons of crude oil per ton of shale, and sixty pounds of sulphate of ammonia. It is estimated that a plant with a capacity of 1,500 long tons per day can retort 547,500 tons per annum, equaling 18,000,000 Imperial gallons of crude oil and 13,687 tons of sulphate of ammonia. The oil may be divided as follows: Gasoline, 2,137,500 gallons; illumi-

The geological authorities at Washington, recognizing this fact, have been devoting considerable attention to the New Brunswick deposit. Increased development in connection with these deposits is looked for within the next few months."

—❁—

RESULTS FROM UTILIZATION OF COAL

AN English writer recently pointed out that there is something more to be got out of coal than smoke, ash and a low percentage of its power and heat. He estimated that in British mines alone there are left annually 115 million tons of dross or slack or unworked coal in friable or unprofitable seams. Half of this is said to be sufficiently rich in hydro-carbons to be suitable for con-

to supply the oil through a number of feeds, as many as four per cylinder on the smallest sizes and more on larger diameters. A horizontal cylinder, on the other hand, even of the largest size that is practicable to build, can be effectively lubricated over its whole surface from a single feed on the upper side. Gravity helps to distribute the oil.

In any internal-combustion engine, some of the lubricating oil is carbonized. In a vertical engine this carbon tends to work down past the piston, fouling the rings and dropping into the crank pit, where it becomes mixed with the bearing oil. In the horizontal type, much of this carbon is pushed into the counterbore, whence it can be removed through a blow-off valve in the bottom

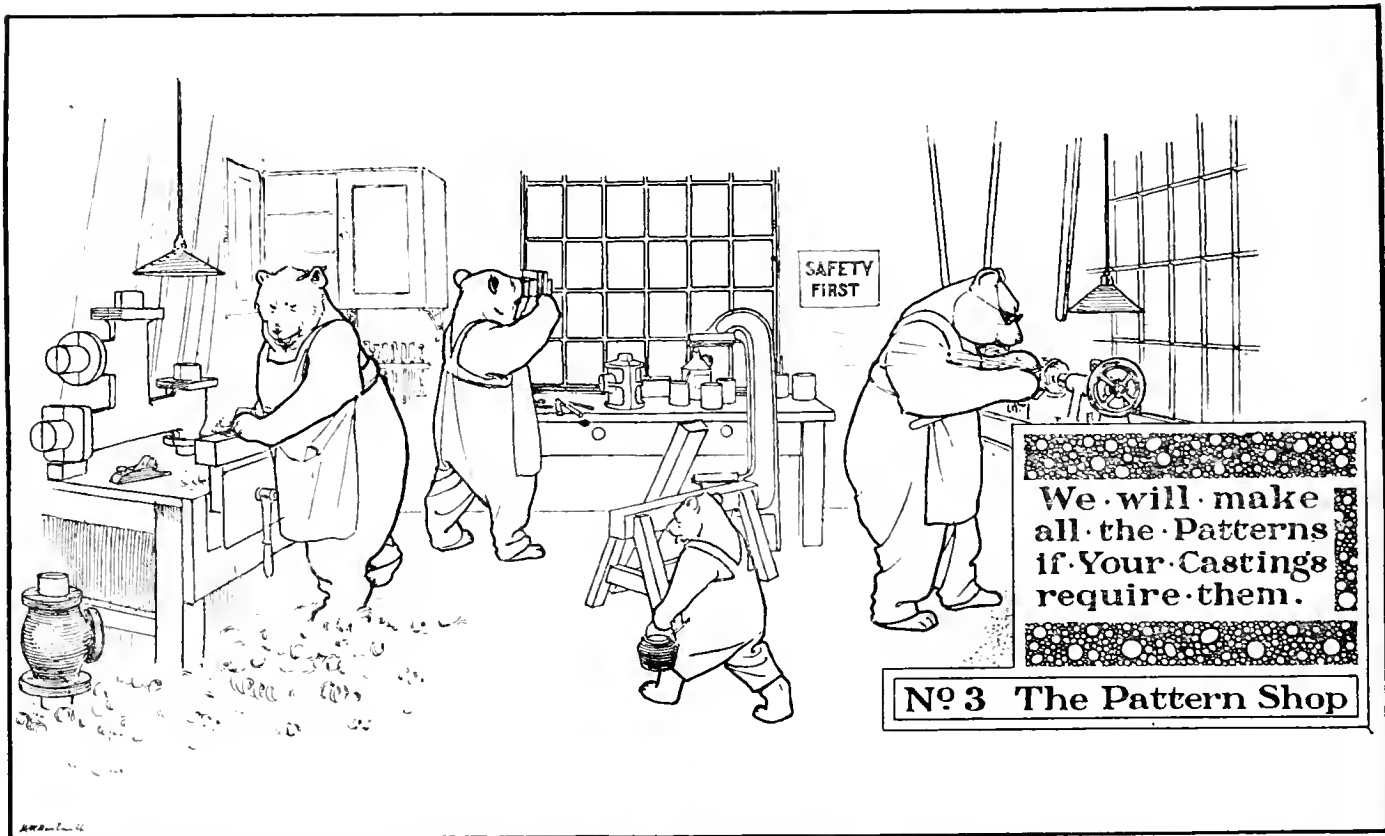

BUSINESS ENTERPRISE IN CARTOON—NO. 3 OF A MONTHLY SERIES APPEARING BY COURTESY OF CANADIAN STEEL FOUNDRIES, LTD., MONTREAL AND WELAND.

nating oil, 7,951,500 gallons; lubricating oil, 2,565,000 gallons; fuel oil, 1,710,000 gallons; paraffine wax, 6,120,000 pounds; coke, 1,530 tons.

This distillation estimate is based upon the old method. By some of the newer methods it is claimed that the New Brunswick shale oil will produce more than three times the above quantity of gasoline per ton. It is believed that there is already sufficient shale available to operate for fifty years at least five plants of the capacity of the one above proposed. The New Brunswick shale is said to be of much better quality than the shale of Colorado, and the quantity is greater.

version in recovery plants, with the following results: Slack and dross available, 57,500,000 tons; benzol, at 2½ gals. per ton, 143,000,000 gals.; Diesel oil, at 1 gal. per ton, 57,000,000 gals.; sulphate of ammonia, at 25 lbs. per ton, 640,000 tons; coke, at 10 cwt. per ton, 28,700,000 tons.

—❁—

INTERNAL COMBUSTION ENGINE LUBRICATION

IN the vertical type of internal combustion engine, it is absolutely essential, in order to secure a distribution of the lubricant around the cylinder bore,

of the cylinder. Such portion as works past the piston can be caught in the frame and prevented from mixing with the bearing lubricating oil. Even the main bearings in a horizontal engine are more effectively lubricated. During the working stroke, when the pressures are highest, the main shaft is partly lifted from the bottom shell, allowing the lubricant to fill the space; again, on the two idle strokes, the exhaust and inlet, inertia effects tend to bring the shaft first against one side of the bearing, then against the other, thus effecting a very thorough distribution of the oil.

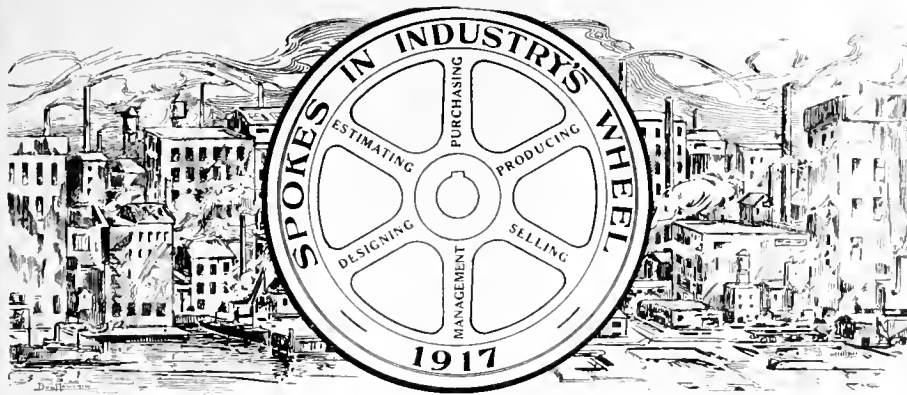

The constitution of industrial enterprise is largely departmental—"spokes in a wheel." This series of articles has for its object the featuring in a racy, interesting and instructive fashion, the training, experience and achievement of those who to-day are transmitting, effectively, energy in their capacity as "spokes in the wheels" of our metal-working establishments.

WILLIAM CASEY

LOCOS come and locos go, but Casey keeps right on the job! The foregoing is not exactly as Tennyson has it, but it expresses the popular sentiment among the numerous friends of William Casey, manager of the Canadian Loco. Company's works at Kingston, Ont. The transient character of the product is in direct contrast to that of the subject of these remarks; born and educated within earshot of the plant—October 13, 1887 was the eventful day—Bill experienced all the thrills and joys incidental to a boyhood admiration for, and ultimate acquaintance with locomotives. As the chief industry of the city, the Locomotive works were the Mecca of all ambitious youths with a bent toward mechanics, so, after acquiring all the available knowledge at St. Mary's School and Regiopolis College—local educational institutions—our subject entered the service of his present employers in the capacity of office boy.

The lure of the locomotive, however, did not allow him to remain a distant admirer very long, and Bill was soon making himself at home in overalls and getting on terms of intimate acquaintance with fireboxes, blast pipes, cross-heads, cranks, and headlights. This sound basis of his present position was supplemented by a term in the drafting room studying the whys and wherefores and also the "ought to be's". That his opportunities for absorbing information had been turned to good account was evidenced by his appointment as machine shop foreman in 1907 at the comparatively youthful age of twenty years, his ability to direct the efforts of subordinates being amply demonstrated during the five years tenure of this position.

From this time, it would seem that the cumulative effect of all Mr. Casey's previous experience was to point to him as "the man," when any "higher up" position became vacant, the result be-

ing that in 1912 he became responsible for all piece work administration and estimating work.

Developments and opportunities succeeded each other rapidly. In 1914, he became assistant to the then vice-president and general manager, (A. W. Wheatley), and in this capacity went through all the strenuous times of munitions production in the early days of the



WILLIAM CASEY.

war. Not that the early days were the only strenuous times by any means. The legitimate resources of many Canadian factories were of very great value to Britain and her Allies, and the production of locomotives, which had declined very considerably after the outbreak of hostilities, was soon resumed with great vigor, record orders, rapid

production, and repeat contracts having been the rule for many months now. The production of a staple line of machinery, to foreign specifications, dimensions and inspection, in rush time, along with shells of various sizes both machined and rough forged, in rusher time indicated a degree of managerial ability which convinced those in authority that talent of no mean order was available when occasion required. It was a matter of general expectation therefore, that as the result of administrative changes done to the resignation of Mr. Wheatley, Mr. Casey should become manager of the Canadian Locomotive Co., the well earned and popular promotion taking place in the early part of last year.

In view of the entrance of the Co. into foreign fields, considerable hopes are entertained regarding future developments in this direction, the bonds of sentiment and mutual interest engendered by the present struggle being likely to prove a factor of some importance and in this respect Mr. Casey's life long association with the Co., will go far to insure a continuance of the good will and international reputation now enjoyed by the concern.

To say that the locomotive works are Kingston is just as much a truism as that Kingston is the Locomotive works, and while Mr. Casey's activities preclude any great political activity, the field for civic effort would seem to hold much promise for the future.



BOILER INSPECTION AT MONTREAL

ALTHOUGH his annual report is a year behind, boiler inspector E. O. Champagne is once more able to inform the public that for the year 1915, no boiler explosions occurred in Montreal. This long immunity from serious boiler accidents has been a feature of Mr. Champagne's reports for many years, and in that connection a letter of congratulations is quoted from the Travelers' Indemnity Company of Hartford. The following is the record for steam boiler inspection for 1915:

Visits of inspection	3,112
Internal and external examinations	1,889
Hydraulic tests	1,621
Hydrostatic tests	606
Imperfect boilers	203
Boilers condemned	4
New and second-hand boilers erected	77
New boilers (included in this number)	65
Notices of inspection issued and received	922

The licenses issued to engineers and others after due examination to take charge of steam boilers was 2,255. Those who failed to pass examinations numbered 127.

Visits made in connection with new devices for smoke abatement were 767

WORLD SHIPBUILDING DURING 1916.

THE outstanding features of the world shipbuilding statistics for 1916, are the decrease in production in the United Kingdom and the great activity in the United States. British shipyards have been so busily employed on naval work that they have done even less merchant work than in 1915, while shipbuilders in the United States have been experiencing a great boom in new contracts, many of them from neutral countries who were good customers of the United Kingdom in pre-war years.

The English, Scottish, and Irish production consisted of 412 merchant vessels of 582,305 tons and 410,281 i.h.p., compared with 517 vessels of 649,336 tons and 540,594 i.h.p. in the previous year—a decrease of 105 vessels, 67,031 tons, and 130,313 i.h.p. It is however, necessary to go farther back than one year in order to find how the work compares with that of normal times. It is less by 882 vessels, 1,139,849 tons, and 956,553 i.h.p. than that of 1914—in which five months of the year was disturbed by the war.

Warship tonnage and all other tonnage built to the order of the British or Allied Governments is excluded from these figures, and the general result is that in 1916 there was launched about one-third of the tonnage of 1914. Going back to the purely mercantile output of 1913, we find United Kingdom totals of 1424 vessels, 1,977,573 tons, and 1,556,560 i.h.p.—not far short of four times those of 1916.

These comparisons are eloquent of two things—(1)—The amount of work of a non-mercantile character that has been done, and (2), the amount of reserve power that will be released in British shipbuilding when the war is over. It would, the writer continues, certainly be a great mistake to infer that they indicate any falling off in producing capacity. Behind them there is a period of unprecedented activity, works extensions, and improvements in plant and in organization that will be invaluable assets to the industry when the war is over, and experience which has proved that those who thought that British shipbuilding had come in 1914 within sight of its limit in productive power had very little idea of what it could really do.

In the foreign production there is an increase from 989,337 tons to 1,335,791 tons. This increase is accounted for almost wholly by the work done in America and Japan. In the United States the production was more than double that of 1915, while from every district there came reports of many contracts and extreme activity. The yards on the Great Lakes did a large amount of work, whereas in 1915 they had a very low tonnage to their credit. In Japan the total was almost three times that of 1915, the increase being accounted for principally by the construction of a good many large cargo steamers. In Holland, shipbuilders were working under exceptional difficulties, and one

firm stated in their report that, owing to the increasing difficulty of obtaining materials, stagnation in their industry was threatened. There were few reports of launches in Germany, and in other Continental countries there were no features of outstanding interest.



MERGE RAILWAYS INTO ONE SYSTEM

IN a paper presented to the Canadian Society of Civil Engineers, recently in Montreal, W. F. Tye dealt with the subject of "Canada's Railway Problems." After giving many figures showing the history of railway development in Canada and the manner in which money had been squandered duplicating roads, Mr. Tye suggested as a solution that the Government authorize the organization of a new corporation to take over the Grand Trunk, Grand Trunk Pacific, National Transcontinental and Canadian Northern railways, and consolidate them into one comprehensive system.

This, he suggested, should be run by the corporation, without any Government interference in the management, although he proposed that the Government should own at least 40 per cent. of the stock and have a proportionate representation in the directorate. With this plan he showed a series of maps and diagrams, indicating the manner in which he considered such a consolidation would do away with overlapping, and permit of the doing away with a lot of the duplication of tracks which was now in existence in both Eastern and Western Canada.

The Grand Trunk Pacific, he said, had a splendid main line, built on altogether too expensive a plan for the traffic. The Canadian Northern had a poor main line, while it had a good supply of feed lines, which the G.T.P. had not. In the east the Grand Trunk supplied a splendid line of feeders, while the Canadian Northern and National Transcontinental would supply an excellent main line and in many sections overlapping parts could be done away with.

His proposition was that by taking the four lines and doing away with as much as possible of the losses caused by extravagant Government finance, overlapping of roads, and other mistakes, and getting the lines into a reasonable condition of efficiency, the mistakes of the past might eventually be overtaken. He proposed that the four lines should be put into a holding company, and, if necessary, the G.T.P. and Canadian Northern liquidated, so as to get on to a firm basis for a start.

It would probably then, he considered, be necessary to spend a large amount during the next five years improving the existing lines and building feeders, but by that time he feared that the increase in business would be such that from a steady loss during the first few years the consolidated railroads would get to a paying basis, probably within five or six years. Mr. Tye put

it that the C.P.R. had been a great financial success, the G.T.R. a moderate success, the Canadian Northern a moderate failure, and the G.T.P. a great financial failure.

The C.P.R. had succeeded by wise planning, wise aid and good management, but Government ownership could never succeed on so vast a plan as that he suggested for the consolidation of the four roads, hence his suggestion for the formation of a company, with stock guaranteed by the Government, which would put it on a 5 per cent. basis. In this way they would avoid the costly experience of the Intercolonial. With the amount of land available, and the possibilities of business he did not see how there could be a failure of such a business consolidation of railways.

The whole situation, he said, had arisen through unwise duplication of railways and a vicious system of bonusing and land granting, which should be stopped. That would end the debauch of railway construction from which Canada was now suffering.



HYDRAULIC RESOURCES AND INDUSTRY

IN estimating the value of Canada's hydraulic resources and their importance with reference to future industrial development, the extent to which electro-chemical processes have entered into some phases, at least, of nearly every branch of our industrial life is not generally appreciated.

A small beginning in electro-plating, two generations ago, has developed until the great bulk of the copper output of the world is electrolytically refined. The electrolysis of common salt is the basis of the electrolytic alkali industry, the products of which are caustic soda, metallic sodium, chlorates, and hypochlorites. The electric furnace has created a host of new industries, producing chiefly abrasives, graphite, silicon, ferro-alloys, refined steel, phosphorus and calcium carbide. It has also been tested experimentally as a competitor of the combustion furnace in the metallurgy of many metals.

Used as an electrolytic furnace, we have the very important application to the production of aluminum. The industrial use of electric discharges through gases is still in its infancy, but we have ozone and nitric acid among the products, the former used for sterilization, and the latter as a basis for fertilizers and explosives.

Every one of these industries consumes large quantities of energy. Whereas the refining of lead requires only 120 k.w.h. per ton, we have consumptions as high as 4,000 k.w.h. per ton for other metals. The aluminum furnace requires 25,000 k.w.h. per ton of product.

The electro-chemical industries have grown to be of great value to countries which possess good opportunities in water power resources, as they have a fundamental interest in the development of cheap power.

PROGRESS IN NEW EQUIPMENT

A Record of New and Improved Machinery and Accessories for the Machine, Pattern, Boiler and Blacksmith Shops, Planing Mill, Foundry and Power Plant

COLUMN SENSITIVE DRILL PRESS

THE illustration shows a floor type of sensitive drill having a capacity up to 1 1/2 in. recently produced by the DeMooy Machine Co., Cleveland, O. This machine is also made in a bench type in which the table arm is hinged on the column close to the cone pulley. The high carbon steel spindle has long bearing support, the lower bearing being provided with additional support by a brace from the column. Steel, fibre steel thrust bearings are used, and a No. 1 Morse taper is provided in the spindle.

Spindle speeds up to 2,000 rev. per min. are obtained, the shaft which carries the belt pulleys and the two-speed cone pulley projecting directly from the column and carrying the belt shifter direct from its outer end. This arrangement enables the belt shifter to be pi-

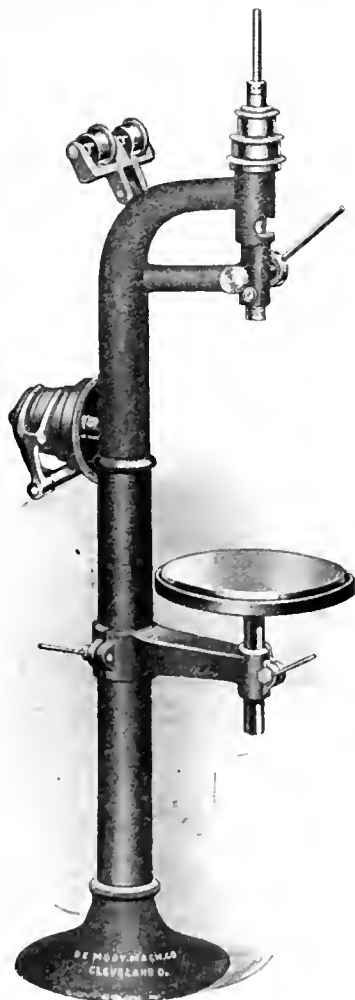

COLUMN SENSITIVE DRILL PRESS.

voted around the pulleys to suit any desired angle of drive.

The net weight of the machine is 110

lbs. in the bench type, which, along with the floor type has the following leading dimensions: Greatest distance spindle to table with table arm up, 12 in.; vertical movement of table, 7 in.; centre of spindle to frame, 7 1/2 in.



SPECIAL TYPE SHAPING MACHINE

AN interesting shaping machine of specialized design arranged for the performance of one specific operation has been built by the Newton Machine Tool Works, Philadelphia. The machine is of very massive construction, weighing 30,000 lbs. and having a stroke of 30 in. The distinctive feature of this machine is the provision of power vertical feed, operated by a pawl engaging an incline which insures an accurate definite amount of feed at each stroke.

Heavy box type construction is adopted throughout, while the drive is similar to that used on crank slotting machines, through connecting rod and Whitworth motion from the motor giving a quick return stroke.

The table is of special design for holding steel locomotive boxes while machining the collar fits, the arrangement adopted serving to increase the visibility of the markings to be worked to. Hand elevation is provided for the knee, as is also a slight amount of hand cross adjustment to the angular table to which the boxes are bolted.

This machine, similarly with another having a circular feed, is driven by a 15 horse-power motor having a speed of from 400 to 1,200 rev. per min.



GAS HOLDER INSTALLATION

CONSIDERABLE interest attaches to the new gas plant recently installed by the city of Sherbrooke, Que., at a cost of about \$100,000, the gas holders being the first to be designed and installed by Canadian engineers. These were built by the Jenckes Machine Co., Sherbrooke, under the supervision of Wm. Rodger, chief engineer, the water

gas plant which forms part of the equipment having been installed by the Western Gas Construction Co., under the supervision of D. J. Sweeney.

Although the fact that coal would yield an illuminating gas, was known long before that date, it was not till 1792 that William Murdoch discovered a process for manufacturing gas from coal, and in 1798 he successfully applied his invention to the lighting of his residence in Old Cumnock, Ayrshire, Scotland. Many improvements and developments in manufacturing equipment have since taken place, the Sherbrooke water gas plant is representative of the latest and best practice, the necessity for effi-

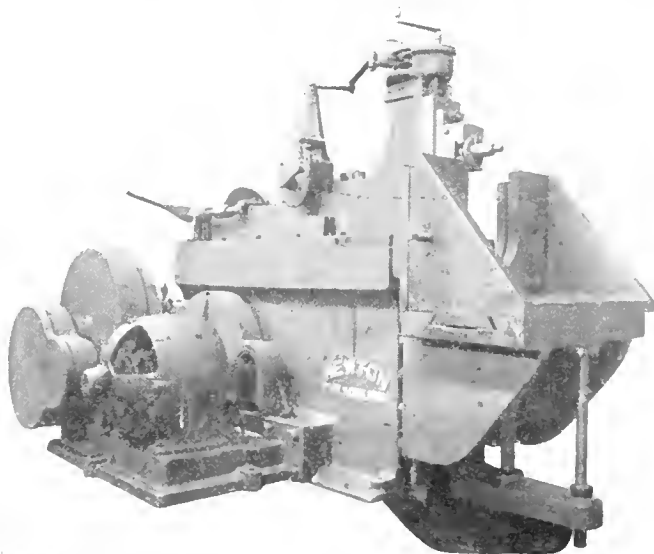

EXTRA HEAVY 30 IN. SHAPING MACHINE FOR MACHINING LOCOMOTIVE BOXES.

cient operation being evident when it is stated that any want of economy in the first stage cannot be compensated for in any of the later stages of the process.

Coke is the material from which the gas is obtained by means of generators, being then enriched by oil for the purpose of increasing its luminosity, the resulting gas then passing successively through scrubbers, condensers, and tar extractors, into a small relief gas holder, after which it is passed through ammonia washers and purifiers till it reaches the large gas holder shown in the illustration.

The generators into which the coke is first deposited are two in number, 11 ft. 6 in. high by 5 ft. dia. of cast iron construction and double lined to a thickness of 10 1/2 in. with heat insulating material, the inner 6 in. being a special grade of firebrick. The carburetters, of which there are also two, are 12 ft. high by 4 ft. 6 in. dia. of similar con-

struction to the generators, and are filled with chequer bricks so arranged as to form a series of baffles to the gas. At the top of the carburetter, heated oil is sprayed in the form of a mist which commingles with the gas from the generator.

The gas is made by passing steam at 100 or 120 lbs. pressure into the bed of incandescent coke in the generator, thereby decomposing it into its constituent gases, oxygen and hydrogen, the former

of 30,000 cu. ft. capacity, having a diameter of 45 ft., and a height of 19 ft. In order to overcome the pressure caused by the resistance of the ammonia washers, the gas is drawn from the relief tank by two Root exhausters, one geared to a 2 horse-power constant speed a.c. motor, and the other direct connected to a vertical steam engine. These machines force the gas through the washers in which it is arranged to bubble upwards through the washing liquid. As the gas rises, it is caught by a perforated screen which sub-divides the particles into a fine foam, the screens being so constructed that the solid matter, precipitated from hard water, will be washed off and drops to the bottom of the washer, at the same time avoiding excessive back pressure due to stopping up.

The final stage is purifying which is done in boxes, 11 ft. 6 in. dia. by 12 ft. deep, after leaving which the gas passes through the meter to the large gas holder, which serves the all important purpose of equalizing the distribution of gas under pressure and insures an unbroken supply so long as any gas remains in it. In form it is cylindrical, with the open lower end submerged

work against guide rails attached to the columns or standards. It has a capacity of 202,000 cu. ft. and is of telescopic construction in two lifts; the inner lift is 70 ft. 8 in. dia. by 25 ft. 6 in. deep, and the outer lift is 72 ft. 7 in. dia. by 26 ft. 1 in. deep. No counter-weights are required in connection with the holder as a result of the use of exhausters and governor.

The crown or roof of the holder is untrussed as the top curb is of sufficient strength to resist distortion by the pressure of the gas; a wooden frame work, however, was erected inside the tank to support the untrussed roof when the holder rests empty on steel landing beams. The main standards are made of steel I beams extending 54 ft. above walk of tank and are tied together midway and top by 24 in. deep lattice girders, diagonal wind ties of round and flat bars imparting increased rigidity to the frame. The tank containing the water into which the holder telescopes is 75 ft. dia. by 26 ft. 3 in. deep, and is built of steel plates having a walk round the top reached from the ground by stairway, while a ladder extends to the top of the standards, the height from the ground level to this point being 80 ft.

The plant described has a capacity of 16,000 cu. ft. of gas per hour.



ELECTRIC FURNACE EQUIPMENT

THE constant broadening of the commercial field of the electric furnace is due largely to the perfecting of furnace design and reduction in cost of power. Whereas their former use was principally in the refining of high grade alloy and tool steels, they are now being more



70 FT DIA GAS HOLDER OF 200,000 CU. FT. CAPACITY AT SHERBROOKE, QUE.

combining with the carbon of the coke to form carbon dioxide, which, rising through the upper layers of the incandescent coke is reduced to carbon monoxide; this last gas finally combines with the free hydrogen forming what is known as "blue gas". Blue gas is non luminous and is therefore enriched with oil in the carburetter so as to possess light giving properties.

The process of manufacture can be continued as long as the fuel in the generator is sufficiently high in temperature to reduce the carbon dioxide to the monoxide. Usually a period of six or seven minutes generation causes the temperature of the fuel to fall too low for this action to continue; the steam and oil are then shut off and an air blast turned into the generator, which in three or four minutes restores the coke to the desired temperature when the cycle of operations is repeated.

Two water sealed scrubbers each 19 ft. 8 in. high by 3 ft. 6 in. dia. receive the gas from the carburetters, after which it passes into condensers 19 ft. high by 3 ft. 6 in. dia. having sixty-one 3 in. tubes, 16 ft. long. Tar removal is the next process, being done in extractor tanks 5 ft. by 5 ft. by 12 ft. long, passing thence into a relief gas holder

in a tank allowing it to work up and down freely. It is guided in its vertical movement by rollers which

widely used for the refining of common grades of steel. Improved devices for charging and tilting, larger electrodes,



ARC TYPE ELECTRIC FURNACE SHOWING ELECTRODES, CHARGING AND POURING DOORS.

and automatic regulation all tend to greater economy.

While many different designs of furnace are in existence, they can be grouped in two general classes, the induction furnace and the arc furnace; the latter, in sizes from one-half to 20-tons hav-

ing higher and more uniform quality. The Thury system has been adopted for a large percentage of the furnaces in use, and can also be adapted for maintaining a constant potential when desired. A three phase furnace equipment is illustrated herewith and consists of

ism, motors for driving same, etc., but the current is kept more uniform by avoiding unnecessary regulation.

Each regulator controls one electrode. The regulator is controlled by a solenoid energized by means of current from series transformers in the main high tension circuit. The regulator in turn controls the armature circuit of the electrode motor to give it motion in either direction, or stop it, as required. This electrode motor operates a hoisting mechanism, which in turn raises or lowers the electrodes. The regulator can handle any amount of power for regulating purposes without impeding the free play of the controlling mechanism, which is only in contact with the power mechanism for exceedingly short periods of time and is otherwise perfectly free. Intermittent action of a contact making arm prevents the regulation from being carried too far in one direction. Thus a high load power factor and a uniform current on the furnace is assured at all times.



Wireless Emphasis.—She sailed into the telegraph office and rapped on the counter. As the clerk came forward to meet her he remembered that she had been there about ten minutes before. He wondered what she wanted this time.

"Oh," she said, "let me have that telegram I wrote just now; I forgot something important. I wanted to underscore 'perfectly lovely' in acknowledging the receipt of that bracelet. Will it cost anything extra?"

"No, ma'am," said the clerk, as he handed her the message.

The young lady drew two heavy lines beneath the words and said—

"It's awfully good of you to let me do that! It will please Arthur ever so much."

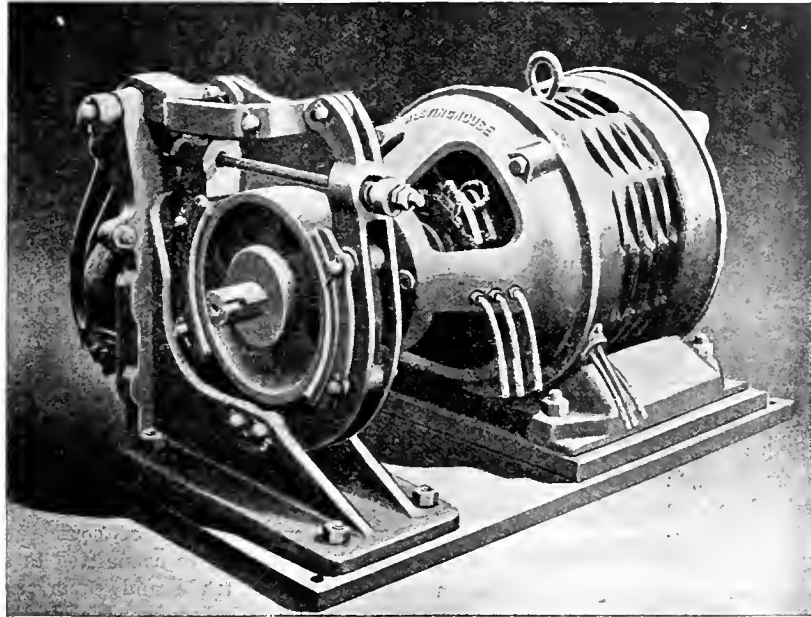

TILTING MOTOR WITH BRAKE GEAR AS USED ON ELECTRIC FURNACE.

ing been adopted almost exclusively in American practice.

The Westinghouse Electric & Mfg. Co., East Pittsburgh, Pa., has developed complete electrical equipments for all classes of furnace, that for the arc type of furnace, assuming high tension alternating current is available, including line protective equipment, switchboard, step down transformers, furnace tilting motors, motors for adjusting position of electrodes, and a regulating system for the control of the electrode motors.

The type of motor employed for operating the tilting mechanism is shown in one of the accompanying illustrations. Either a.c. or d.c. motors are suitable, having characteristics similar to those used for hoisting work. The controller is of the reversing type and a motor brake is used to prevent over-travel of the furnace and hold it in any desired position, a complete line of motors from 15 to 150 horse-power being available for this work.

Where automatic control of the electrode is desired, a motor operated hoisting mechanism is provided for each electrode. As the motors are mounted on the furnace which tilts, the bearings are built with special lubricating features. Shunt-wound direct current motors are selected for this service, enabling a more simple and positive system of control to be used than when alternating current is used.

Automatic regulation has as its object the maintaining of a constant current at the furnace resulting in higher furnace efficiency and increased output of

three regulating drum controllers; three field regulators; three resistances, two series transformers, and one motor with shafting etc.

Damping devices permit the regulator to act only when necessary, and sudden changes and peaks of short duration do not put the regulator in action. This in itself is very important, as there is not only a great saving in the wear and tear of the electrodes hoisting mechanism,

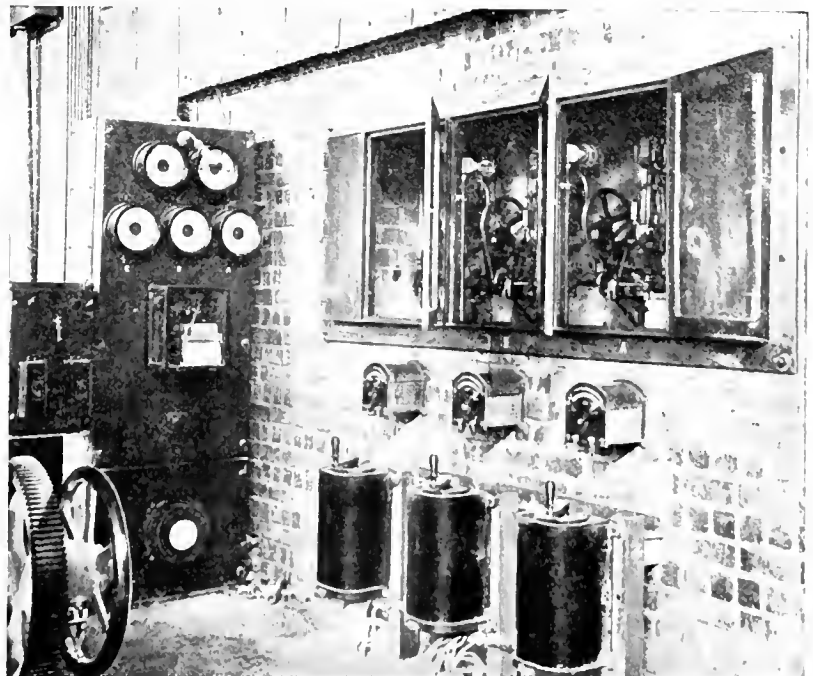

VIEW OF AUTOMATIC REGULATOR EQUIPMENT FOR CONTROLLING ACTION OF FURNACE ELECTRODES

The MacLean Publishing Company

LIMITED

(ESTABLISHED 1888)

JOHN BAYNE MACLEAN - - - - - President
H. T. HUNTER - - - - - Vice-President
H. V. TYRRELL - - - - - General Manager

PUBLISHERS OF

CANADIAN MACHINERY AND MANUFACTURING NEWS

A weekly newspaper devoted to the machinery and manufacturing interests.

PETER BAIN, M.E., Editor. B. G. NEWTON, Manager.

Associate Editors.

A. G. WEBSTER, J. M. WILSON, J. H. RODGERS.

Office of Publication, 143-153 University Avenue, Toronto, Ont.

Vol. XVII. FEBRUARY 1, 1917 No 5.

OUR MUNITIONS MANUFACTURING OUTLOOK

NOTWITHSTANDING the now well-established fact that peace in Europe will be consummated through victory, and that it has been determined to the fullest extent possible to meet the multitudinous equipment requirements of our armies in training and in the trenches by the utilization of Empire labor and material resources, some misgiving appears to prevail concerning Canadian munition contract renewals covering the third and fourth quarters of this year. Few people, however, are to be found who are in the least degree sanguine as to a cessation of hostilities during either period. For misgivings under any circumstances, there are usually—we might say always, reasons or causes, substantial or imaginative. Without, however, seeking to probe these too deeply, may we point out—aside from a "Peace with Victory" development during the present year, a few facts relative to the production of munitions for Empire requirements generally.

We are apt at times to forget that our activities are for the accommodation of the Imperial Government, and that the placing of munition orders—quantities of shell of variety, type and size, is not an indiscriminate proceeding and based wholly on a reckoning that, if there be available a good supply of each type and size, all will be well. This war, irrespective of its numerous shortcomings in prosecution, is being engineered, and, as might therefore be expected, is exemplary of much sound scientific management. We are probably right in saying that up to January 1 of the present year, shells called for in Canada have been based on three monthly periods, at the end of which, quantities, types and sizes further required were liable to differ materially and have actually done so, although maintaining the type and size ranges prevalent.

When this feature of the situation is fully appreciated, and especially so its engineering or scientific management aspect, the reasons for such a line of action are not far to seek. Stated briefly, any three months' experience in the field determines the suitability or effectiveness of the munition detail employed, and, as we see it, can hardly fail to influence materially the quantity, size and type of shell when orders come to be placed in the succeeding quarter. Again, isn't it reasonable to assume that requirements more or less immediately antedating a big offensive will find expression in shell contract detail distinctiveness.

Canadian metal-working plant executives are in a number of cases worrying as to their prospects for re-

newal orders after June 30 of this year, at which date we understand all existing contracts expire. This is perhaps not an unnatural state of affairs. In our estimation, however, we are yet well beyond five months removed from the cessation of quantity and variety shell orders, and consequently from peace-time commodity production.

As bearing out our views, it may be noted here that in the past twelve months much switching took place relative to the constitution of shell orders placed in Canada, and our anticipations are that the next new period contracts will but witness action more or less similar in its scope and effect to that experienced in the past. The switching from one type or size of shell to that of another is to-day less irksome, both from the equipment and operator viewpoints, for equipment is not only more readily available than say a year or so ago, but is more efficient for its purpose. The experience of the operator is also such as to make him tackle confidently the production of shell other than those on which he has been for the most part engaged. While it may be said that "Peace with Victory" is appreciably nearer than "Peace without Victory," its imminence is not, we make bold to say, such as to affect the intensive manufacture of munitions in Canada during the third and fourth quarters of the present year at least.

POST-WAR TRADE PREFERENCES

AN impression is abroad that, as a result of the Economic Conference held in Paris, France, some few months ago, the Allied Nations are committed to a hide-bound scheme whereby their trade and commerce after the war will be quite exclusive. In a word, a worthwhile preference will be made effective as regards all forms of their business intercourse. Just how such an idea originated is rather difficult to determine: this much, however, may be said, that no official statement may be cited from which to draw any such conclusion, much less that plans to that end have as yet been initiated or are in process of development. We have good reason for believing that beyond stimulating une bonne entente, the Paris Conference accomplishment is otherwise valueless.

The trouble about preference ideas being appropriated and nursed is the tendency to restriction of effort and enterprise and the disposition to make use of a business prop of questionable strength, and lean on it over-heavily. Such a state of affairs may not be wholly unknown in Canadian industry. On the other hand, prospective preferences among the Allied Countries have a stimulating effect on the business enterprise of Neutrals, arousing as it does a desire to establish themselves—parent or subsidiary plant, in favored territory. Evidence of the latter is not meantime wanting in the quest by many American industrial concerns for factory locations and sites in our midst, and their desire to glean the fullest possible information regarding after-the-war trade prospects. Much as we welcome their coming, we may not influence it on the score of assumed trade preferences following the war.

In spite of the many prophecies, eloquent speeches, discussions by representative bodies, and resolutions relating thereto, it can be stated positively that no man nor body of men have meantime the slightest idea as to conditions immediately following the war, relative to world trade and commerce, or otherwise. The only thing of importance just now, here or in the Allied Countries, is the prosecution of the war to an early and victorious finish. Opportunity in plenty will then be afforded not only to remodel the broken face of civilization, but to plan tactfully and effectively for its all-time preservation. When this work is done, trade preference vaporings may have become still air.

INDUSTRIAL NOTABILITIES

JAMES ALEXANDER McMAHON, treasurer and managing director, Union Drawn Steel Co., manufacturers of high grade cold die rolled steel and shafting, pump rods, piston rods and special shapes, special screw stock, rounds, squares and hexagons, was born in Venango County, Pa., Dec. 18, 1859, son of John and Margaret (Wolf) McMahon. He was educated at Public Schools of Pennsylvania, supplemented by a Commercial Course at Oberlin, O. He conducted a Commercial College at Beaver Falls, Penn., 1887-1892; was



JAMES ALEXANDER McMAHON

with Swan Electric Co., Cleveland, O., 1892-1893; with Union Drawn Steel Co., of Beaver Falls, Penn., 1893-1905; came to Hamilton in 1905 and established the present business.

Mr. McMahon is a member of Executive Committee, Hamilton Branch, Canadian Manufacturers' Association; member of Membership Committee, C.M.A., for all of Canada; and was chairman of Membership Committee, C.M.A., 1911, for the Dominion; member Technical Committee, Hamilton School Board; member Hamilton Board of Trade. He married Jennie G. Beegle, daughter of Benjamin F. Beegle, July 25, 1889; has one son and one daughter. His Clubs are: Commercial; Royal Hamilton Yacht; Canadian; and his Societies: A.F. & A.M. In Politics he is Conservative; and in Creed: Methodist. His residence is at 81 Barnsdale Boulevard, Hamilton, Ont.

— Photo courtesy British and Colonial Press.

BOILER TUBES.

Size.	Seamless	Lap-welded
1 in.	\$30 00
1 1/4 in.	30 00
1 1/2 in.	30 00	24 00
1 3/4 in.	29 00	21 00
2 in.	33 00	20 00
2 1/4 in.	33 00
2 1/2 in.	25 75	26 50
3 in.	55 00	31 00
3 1/4 in.	54 50	36 00
3 1/2 in.	59 50	39 00
4 in.	75 00	49 00

Prices per 100 feet, Montreal and Toronto.

OILS AND COMPOUNDS.

Castor oil, per lb.	25
Royalite, per gal., bulk	12
Machine oil, per gal.	25 1/2
Black oil, per gal.	12 1/2
Cylinder oil, Capital	45 1/2
Cylinder oil, Acme	36 1/2
Standard cutting compound, per lb.	9 6
Lard oil, per gal.	1 45
Union thread cutting oil antiseptic	68
Acme cutting oil, antiseptic	37 1/2
Imperial quenching oil	39 1/2
Petroleum fuel oil	103 1/4

BELTING—NO. 1 OAK TANNED.

Extra heavy, single and double	30-50c
Standard	40c
Cut leather lacing, No. 1.	\$1 50
Leather in sides	1 30

TAPES.

Chesterman Metallic, 50 ft.	\$2 00
Lufkin Metallic, 603, 50 ft.	2 00
Admiral Steel Tape, 50 ft.	2 75
Admiral Steel Tape, 100 ft.	4 45
Major Jun. Steel Tape, 50 ft.	3 50
Rival Steel Tape, 50 ft.	2 75
Rival Steel Tape, 100 ft.	4 45
Reliable Jun. Steel Tape, 50 ft.	3 50

WASTE.

White	Cents per lb.
XXX Extra	20
Peerless	20
Grand	19
Superior	19
X L C R	18
Atlas	18
X Empire	18
Ideal	17
X press	16

COLORED.

Lion	14 1/2
Standard	13
No. 1	13
Popular	11 1/2
Keen	10 1/2

WOOL PACKING.

Arrow	25
Axle	20
Anvil	15
Anchor	11

WASHED WIPERS.

Select White	12
Mixed colored	10
Dark colored	09

This list subject to trade discount for quantity.

RUBBER BELTING.

Standard	50c
Best grades	30c

ANODES.

Nickel	.50 to .54
Cobalt	1.75 to 2.00
Copper	.44 to .46
Tin	.49 to .56
Zinc	.23 to .25

Prices Per Lb.

COPPER SHEETS.

	Montreal	Toronto
Bars, 1/2 to 2 in.	\$46 00	\$46 00
Plain sheets, 14 oz., 14x28 in., 14x60 in.	45 00	45 00
Copper sheet, tinned, 14x60, 14 oz.	54 00	54 00
Copper sheet, plainished, 14x60 base.	57 00	57 00
Braziers' in sheets, 6x4 base	46 50	46 50

BRASS.

Brass rods, base 1/2 in to 1 in rd.	0 55
Brass sheets, 8 in. wide, 20 oz.	0 60
Brass tubing, seamless	0 55
Copper tubing, seamless	0 55

PLATING SUPPLIES.

Polishing wheels, felt	2 10
Polishing wheels, bull-neck	1 35
Emery in kegs, American	06
Pumice, ground	04
Emery glue	15 to 20
Tripoli composition	04 to 06
Crocus composition	07 to 08
Emery composition	08 to 09
Rouge, silver	35 to 50
Rouge, powder	30 to 35

Prices Per Lb.

LEAD SHEETS.

	Montreal	Toronto
Sheets, 3 lbs. sq. ft.	\$12 00	\$12 50
Sheets, 3 1/2 lbs. sq.		

ft.	11 75	12 25
Sheets, 4 to 6 lbs. sq. ft.	11 50	12 00
Cut sheets, 1/2 lb. extra.		
Cut sheets to size, 1c per lb. extra.		

PLATING CHEMICALS

Acid, boracic	\$ 15
Acid, hydrochloric	.45
Acid, hydrofluoric	.14 1/2
Acid, nitric	.10
Acid, sulphuric	.05
Ammonia, aqua	.08
Ammonium carbonate	.15
Ammonium chloride	.11
Ammonium hydrosulphuret	.40
Ammonium sulphate	.07
Arsenic, white	.12
Copper, carbonate, anhy.	.35
Copper, sulphate	.17
Cobalt sulphate	.50
Iron perchloride	.20
Lead acetate	.16
Nickel ammonium sulphate	.12
Nickel carbonate	.35
Nickel sulphate	.15
Potassium carbonate	.75
Potassium sulphide (substituted)	.20
Silver chloride (per oz.)	.65
Silver nitrate (per oz.)	.55
Sodium bisulphite	.10
Sodium carbonate crystals	.65
Sodium cyanide, 127-130%	.41
Sodium hydrate	.04
Sodium hyposulphite, per 100 lbs.	5 00
Sodium phosphate	.14
Tin chloride	.60
Zinc chloride	.60
Zinc sulphate	.09

Prices Per Lb. Unless Otherwise Stated.

The General Market Conditions and Tendencies

This section sets forth the views and observations of men qualified to judge the outlook and with whom we are in close touch through provincial correspondents

Montreal, Que., Jan. 29—Difficulties of transportation are probably the chief feature of interest in the industrial situation at present, the lack of sufficient facilities for handling the numerous urgent classes of freight having had a serious effect on certain trade conditions through the placing of embargoes. Weather conditions have tended to aggravate matters, particularly the coal shortage, which has made itself felt in domestic as well as industrial circles.

Pig-Iron

Pig-iron production has been affected more, perhaps, than any other allied line, through the serious coke situation, and as a result the output has fallen off. The market has not developed any special feature, but continues to maintain its abnormal strength.

Steel

Curtaiment of output has followed the shortage of raw materials, resulting from the inability to obtain delivery, owing to difficulty of transportation. Car shortage and freight embargoes have tied up needed materials to the extent that some plants have been closed down temporarily, while others are operating light. Business is brisk in billets and sheet bars, and top prices are still the feature. Prompt deliveries on plates are still demanding premiums, and in some instances

impossible to get even with this consideration. Owing to the heavy export of steel rails, mills are quite active on those lines. Activity in sheets is not so pronounced and mills are accepting business more freely. The stronger tendency of spelter may affect the quotation on sheets, but some little time must elapse before this becomes evident. Contracts are being placed for last half tin plate, irrespective of price, this to be adjusted at a later date. The shafting situation is showing relief, as producers are running in advance of expectations and delivery is becoming more normal. No developments are noted in the wire situation, and it is generally anticipated that prices will remain steady for some time. Iron and steel bars show a little easier, but the demand is fairly active. Boiler tubes and pipes are much in demand, consumers still being under-supplied. The local situation continues very steady, with no advances reported.

Metals

The tone of the general market is much stronger and prices show an upward tendency. The feeling is strong that negotiations may soon be opened for future metal requirements for the Allied powers and this is affecting present conditions. Copper has regained much of the recent loss. Tin is unsettled,

but firm. Spelter appears stronger, while lead is higher on a speculative basis. Antimony features the market with a sharp advance. Aluminum is steady, but easier.

Copper—Copper is in a very strong position, owing to the sold-up condition of the market. It is very difficult to secure much metal for early delivery. Holders of metal are loth to part with it and the tendency seems to be for a still stronger market. Producers are practically out of the market, refusing to quote on future delivery. This attitude is due to the possibility that the Allies may soon be covering their last half requirements. The local market is active, and developing additional strength, dealers here having advanced prices 1/2c per lb. Lake and electrolytic are now 36 1/2c, with castings 35 1/2c lb.

Tin—The market is still featured by the nervousness that prevails, owing to the uncertainty of the situation, caused by the lack of information regarding tin shipments. The general situation shows little change and the strength of the market may be largely accounted for by the dangers that are prevalent in the transportation of the metal. London quotations are stronger, but New York is 3/4c lower than a week ago, the present nominal price being 45 1/2c per lb. The market here is fairly active and dealers have added one cent to their listed prices, quoting 48c per lb.

Spelter—The backward attitude of producers and sellers has resulted in a stronger market, but consumers are not showing increased interest in the situation, and the demand is not heavy. Pres-

ent conditions have resulted from the possible requirements for export purposes during the coming months. The London situation continues steady, while New York reports of $3\frac{1}{2}c$ on the week, the price asked being $10\frac{3}{4}c$ per lb. On a fairly good demand local dealers have advanced their quotations to $14\frac{1}{2}c$, this being one cent higher than last week.

Lead—The action of independents in advancing prices would appear to indicate a stronger market, but this strength is due more to speculation than to actual conditions. While situation is very firm, the leading interests are content to hold to their present prices, realizing that little is to be gained by forcing the market at this time. The trust price holds at $7\frac{1}{2}c$, while outside quotations have advanced to the nominal figure of $8\frac{1}{4}c$ per lb. The market here has been quite active and dealers are quoting $10\frac{1}{2}c$, an advance over last week of $\frac{1}{2}c$.

Antimony—The apparent scarcity of antimony and the small quantity available has resulted in a sharp advance in prices asked. The curtailment of output from some of the Chinese refineries is also affecting the situation. The advance on the New York market is about 6c per lb., the nominal quotation being $21c$ per lb. The market here is strong and dealers are asking $18c$, an advance of $2c$ on the week.

Aluminum—Market quiet and unchanged, prices easy at $70c$ per lb.

Machine Tools and Supplies

Business is not over-active, but sufficient volume is passing to maintain the interest of the trade. The manufacture of munitions has reached the stage where orders for bulk equipment have been largely filled, and dealers can only report sales of single or small lots of machinery. In some localities brisk business is being carried on in the manufacture of marine engines and accessories, and additional machine tools have been placed to take care of this product. The demand for general supplies continues fairly heavy and prices in many instances are still inclined upward.

Scrap

Railroad embargoes and freight congestion are affecting the shipment of materials, and it is often difficult to obtain delivery. The continued shortage of coke has created an increased demand for turnings and borings, with the result that this class of scrap has become quite active. Low phosphorus scrap is in heavy demand. A firm outlook is expected until relief is shown in railroad transportation. The local situation is active, and dealers have advanced prices. Old coppers are $2c$ higher, quotations ranging from $22c$ for light to $26c$ for heavy. Composition turnings are one cent higher at $18c$. Brass clippings with a similar advance are quoted at $17\frac{1}{2}c$. Machine cast iron has advanced to $21c$, while an advance of $2c$ on steel turnings raises the price to $9c$. Shafting is now $21c$, stove plate $14c$, scrap zinc $8\frac{1}{2}c$, and aluminum $36c$; these prices all indicating an advance of one cent per lb.

Toronto, Ont., Feb. 1.—The outstanding feature is the railroad situation. It is undoubtedly more serious, as the shortage of transportation facilities is hampering manufacturing operations to a greater extent on account of the difficulty in obtaining raw materials and coal. Cars continue to be held up and shipments delayed, notwithstanding the efforts that are being made to secure relief. The railways are handicapped by a shortage of cars and labor, while the severe weather has made operating conditions more difficult to control. Passenger schedules have been reduced to provide additional motive power, and a strong effort is being made to cope with the situation.

Steel

An acute situation has developed in the iron and steel trade on account of the transportation difficulties and consequent scarcity of coke. Supplies of coke are so difficult to obtain that furnaces cannot be operated at capacity, and the output of steel is, therefore, restricted. Practically the entire output of the mills is required for munitions, and wire and wire products for export, thus leaving a very small tonnage to meet the domestic demand. In this respect the situation is getting worse owing to the reduced production, causing considerable inconvenience to domestic consumers. This, however, is unavoidable, as war requirements have first call on the mills. All the steel companies have heavy commitments for this year, and have also considerable tonnage on their books for 1918. The situation is, therefore, very strong, and there is no indication at present of any weakness. Although steel prices are at a high point, there is every possibility of further advances, particularly in some lines, if they are to reach levels in keeping with the cost of raw materials. Prospects of an early peace having been dissipated, the steel market has assumed renewed strength, which will no doubt be maintained until final peace negotiations are renewed. When this desirable condition materializes, negotiations will doubtless cover an extended period during which time the market will become to some extent adjusted in accordance with the new conditions, and prices will probably be more or less stationary for a time before any pronounced weakness develops in the way of lower values. In the meantime, export demand continues good, but the steel companies are experiencing much difficulty in filling orders owing to the scarcity of raw materials. Deliveries are more backward than ever, for the reasons stated above, particularly on plates and wire rods, for which there is a heavy demand.

Unlooked-for developments in the steel market in the United States tend to a belief that capacity production is unlikely, at least for several months. Railway embargoes have resulted in a curtailment of steel production, and the mills are falling behind on deliveries. Shortage of cars has resulted in supplies of coke being cut off, seriously affecting the mills by lowering production and

restricting the shipment of finished steel. Prices of raw materials, such as ferromanganese, speigleisen and ferro-silicon, are advancing, while coke and labor costs are also higher.

Pig Iron

The pig iron situation is getting more acute owing to the shortage of coke, which is affecting furnaces both in Canada and the United States. The Steel Company of Canada have let one furnace down, while the other is only operating at about two-thirds capacity. As the furnace which is not in operation was producing foundry iron, there is practically no domestic pig iron of this grade to be obtained. The furnace which is in operation is producing basic pig iron for steel-making. Grey iron foundries are also suffering from the shortage of coke, and some plants have been obliged to shut down. It is reported that over twenty furnaces in the Pittsburgh district have shut down owing to the coke situation. Canadian consumers are buying considerable tonnages of pig iron from United States' furnaces. No quotations are obtainable on Canadian pig iron, and United States grades are unchanged.

Scrap

The market for scrap is firm and steady, with prices unchanged. The embargo on the export of steel turnings has been lifted again, but is still in force on other steel scraps. Stocks of steel turnings have accumulated, and there is a greater supply than can be used. There is a continued heavy demand for heavy steel scrap, and prices are holding very firm. Ingot metals are firmer, with a fair demand.

Machine Tools

The machine tool situation is unchanged. Business continues quiet, although there is some demand for single tools. Consumers generally are awaiting developments pending a decision regarding further shell contracts.

Metals

The elimination of peace talk has had a favorable effect on the metal market, and the situation generally has improved. There is a firmer undertone throughout, and advances have been registered in tin, lead, antimony and solders. Business locally continues very good, and the trade is in a prosperous condition.

Copper.—There has been very little copper offered for sale lately, and second-hand metal is off the market. The position of copper continues to be a very strong one, and higher prices appear to be likely. Quotations are still nominal, and are unchanged at $36c$ per pound.

Tin.—The advance in London has been reflected in higher prices here, although New York is unchanged. Tin is now quoted locally at $47\frac{1}{2}c$ per pound.

Spelter.—There is an improved sentiment in the market, and a better demand for spelter. The outlook, however, is unsettled, as spelter would be adversely affected by further peace proposals. Local price unchanged at $13\frac{1}{2}c$ per pound.

Lead.—The market is strong and quotations nominal. The "Trust" is holding the price at 7.50c New York, but the "Independents" are quoting 8c to 8½c New York. Quotations locally have advanced ½c, and lead is now 10c per pound.

Antimony.—Quotations are higher, but nominal with a strong market, due to improved demand. Antimony is now quoted at 20c per pound.

Aluminum.—The market is dull and easy, with quotations unchanged at 68c per pound.

Solders.—The advance in tin and lead has been followed by higher prices on solders. The new quotations are ¼c per pound higher.



CANADA'S PROSPEROUS YEAR

PROBABLY one of the most interesting studies of the improvement in the economic position of the Dominion is to be found in a contrast of the business reviews issued by the Canadian Bank of Commerce for the past three years. From the depression and uncertainty that existed after the outbreak of the war to the development and decision that characterize trade operations at the present time would, were it not for the war, be an evolution covering at least a decade. Marvellous, therefore, as has been the transformation, it is by no means to be taken as a sign of complete commercial independence, for when the war is concluded the adjustment to peace conditions unless carried on with care and foresight, may to a greater or less extent interfere with the continuity of commercial progress and expansion for which 1916 was a banner year.

High Grain Prices

Canada's crops last year, despite the forebodings early in the season about a partial failure, were a success from a financial point of view. On the completion of harvesting in 1915 it became evident that we had been favored with a "bumper" crop, and the Northwest Grain Dealers' Association in November estimated the wheat crop at 307,230,000 bushels, our own estimate at that time being 320,275,000 bushels.

In previous years the Grain Dealers' September estimate has seldom been wide of the mark, but the farmers' deliveries to 31st August last revealed the fact that the 1915 wheat crop had exceeded even their November estimate by 70,000,000 bushels—that the crop had not merely been a "bumper" one, but represented a yield never before obtained in the grain-growing areas of any portion of western North America. The average yield of wheat for the three provinces was 30.2 bushels per acre.

Goods Fortune for Farmers

In 1916 the crops again gave exceptional promise until the end of July, when for the second time in twelve years black rust swept over the wheat fields of the Northwestern States and crossed into Manitoba, gradually spreading into the Southern half of Saskatchewan.

Over the greater portion of Manitoba the damage was so severe that many fields yielded nothing, others only 6 to 7 bushels of feed wheat, and the average yield for the province was only 11 bushels of a low grade. Fortunately, Alberta escaped entirely and most of Northern Saskatchewan was affected only slightly, while in Southern Saskatchewan severe damage was confined chiefly to the eastern half.

Consequently with the extraordinarily high prices prevailing, it has been a year of great good fortune for farmers in Alberta and in part of Saskatchewan, and a year of disappointment for farmers in the remainder of Saskatchewan and in Manitoba. Even as to the latter, however, it is to be remembered that it was not a season of general crop failure. Oats and barley gave a fair yield, so that mixed farmers in the rust affected areas have not suffered any marked setback.

Live Stock Industry

The live stock industry shows a continuing development, and reports from most districts indicate a more pronounced disposition on the part of the smaller farmers to acquire stock. The progress made last year and in the past five-year period is indicated by the following figures of farmers' holdings of stock issued by the Provincial Governments:

	1910.	1914.	1915.
Horses	1,439,496	1,574,367	1,617,437
Cattle	1,822,020	2,460,419	2,687,437
Hog ..	676,615	1,553,565	1,015,679
Sheep	352,379	754,040	793,601

Cattle and sheep appear to be more in favor at present than hogs, and this finds confirmation in the following statistics of the receipts at the winnipeg stock-yards for the first ten months of 1915 and 1916, respectively:

	1915.	1916.
Cattle	110,057	120,064
Hogs	422,426	266,218
Sheep	9,952	15,656

Coal in Alberta

The coal mining industry of Alberta, notwithstanding the shortage of labor, shows a very large increase in the quantity of coal mined, due partly to the increased demand and partly to the fact that a steadier production was rendered possible by dealers ordering supplies in good time instead of waiting until the approach of winter, the season of car shortage. The figures in tons for the past three years are:

1914	3,821,739
1915	3,434,891
1916	4,300,000 (Est)

The immigration of settlers from the United States to the western provinces shows a revival. The figures for the ten months ending 31st October are:

	No.	Cash	Effects
1915	3,559	\$2,022,918	\$285,950
1916	4,788	2,825,756	854,152

Pacific Coast

Throughout British Columbia a much

improved tone prevails in comparison with that recorded in our last report: business is larger in volume and improved in quality, while payments have been made with greater promptness than heretofore. There is a general scarcity of labor, though some improvement has taken place since the crops on the prairies were harvested and the laborers returned. The population of the province, however, has unquestionably been reduced, though mainly through the re-enlisting of over 30,000 men for overseas service. The cost of living, in this province as elsewhere, has increased, but a spirit of economy is more general and the people are becoming more reconciled to having to study what to do without rather than what to spend.



TRADE ENQUIRIES

FURTHER particulars regarding the following enquiries may be obtained from the Department of Trade and Commerce, Ottawa.

400—Chemicals.—A reliable English firm of commission agents located in Buenos Ayres would like to hear from Canadian manufacturers of sulphate of alumina and other heavy chemicals used in the manufacture of soap, matches, paper, etc.

401—Iron and steel bars, wood-pulp, fencing wire.—An English firm of manufacturers' representatives would like to receive quotations e.i.f. Buenos Ayres, for iron and steel bars, wood-pulp, fencing wire, if shipment of same can be made immediately.

402—Asbestos.—A Japanese firm in Tokyo wishes to get into touch with suppliers of asbestos in Canada.

403—Sulphuric Acid.—A London firm who deal in sulphuric acid would be glad to receive offers from Canadian manufacturers.

427—Iron and Steel.—A Johannesburg commission house, familiar with the iron and steel trade, seeks the representation of Canadian manufacturers of bar iron, angle iron, iron tubing and wire nails. Immediate correspondence requested.

412—Oxides of Cobalt.—A London manufacturing company asks to be placed in direct touch with Canadian producers of oxides of cobalt, both black and prepared, and also of cobalt metal.



CUBAN DEMAND FOR GASOLINE MOTORS

UNITED STATES CONSUL, R. M. BARTLEMAN, Cienfuegos, Cuba, in a report to his Government published in the Commerce Reports, says that a very fair demand for gasoline motors exists in the Cienfuegos district, but on account of the excessive advance in the price of gasoline there is a tendency to turn to the crude-oil engine.

The following quotations have been ob-

Enlarged Canadian Trade Intelligence Service

Under the arrangement made by the Minister of Trade and Commerce with Sir Edward Grey in July, 1913, the Department of Trade and Commerce, Ottawa, is able to present the following list of the more important British Consulates whose officers have been instructed by the Foreign Office to answer inquiries from and give information to Canadians who wish to consult them in reference to trade matters.

BRAZIL—Bahia, British Consul. Rio de Janeiro, British Consul General.	NETHERLANDS—Amsterdam, British Consul.
CHILE — Valparaiso, British Consul General.	PANAMA—Colon, British Consul. Panama, British Vice-Consul.
COLOMBIA — Bogota, British Consul General.	PERU—Lima, British Vice-Consul.
ECUADOR—Quito, British Consul General. Guayaquil, British Consul.	PORTUGAL—Lisbon, British Consul.
EGYPT — Alexandria, British Consul General.	RUSSIA—Moscow, British Consul General. Petrograd, British Consul. Vladivostok, British Consul. Odessa, British Consul General.
FRANCE—Havre, British Consul General. Marseilles, British Consul General.	SPAIN—Barcelona, British Consul General. Madrid, British Consul.
INDIA—Calcutta, Director General of Commercial Intelligence.	SWEDEN—Stockholm, British Consul.
ITALY—Genoa, British Consul General. Milan, British Consul.	SWITZERLAND—Geneva, British Consul.
MEXICO—Mexico, British Consul General.	URUGUAY—Monte Video, British Vice-Consul.
	VENEZUELA — Caracas, British Vice-Consul.

Canadian Commercial Intelligence Service

The Department of Trade and Commerce invites correspondence from Canadian exporters or importers upon all trade matters. Canadian Trade Commissioners and Commercial Agents should be kept supplied with catalogues, price lists, discount rates, etc., and the names and addresses of trade representatives by Canadian exporters. Catalogues should state whether prices are at factory point, f.o.b. at port of shipment, or, which is preferable, c.i.f. at foreign port.

CANADIAN TRADE COMMISSIONERS.

ARGENTINE REPUBLIC—H. R. Poussette, Reconquista, No. 46, Buenos Aires. Cable address, Canadian.
AUSTRALIA—D. H. Ross, Stock Exchange Building, Melbourne. Cable address, Canadian.
BRITISH WEST INDIES—E. H. S. Flood, Bridgetown, Barbadoes, agent also for the Bermudas and British Guiana. Cable address, Canadian.
CHINA—J. W. Ross, 13 Nanking Road, Shanghai. Cable address, Cancom.
CUBA—Acting Trade Commissioner, Lonja del Comercio, Apartado 1290, Havana. Cable address, Cantracon.
FRANCE—Phillipe Roy, Commissioner General, 17 and 19 Boulevard des Capucines, Paris. Cable address, Stadacona.
JAPAN—G. B. Johnson, P. O. Box 109, Yokohama. Cable address, Canadian.
HOLLAND—Acting Trade Commissioner, Zuidblaak, 26, Rotterdam. Cable address, Watermill.
RUSSIA—C. F. Just, Canadian Government Commercial Agent, Alexandriyskaya, Ploshch 9, Petrograd. L. D. Wilgress, Canadian Government Commercial Agent, Bukhgozla Ulitza No. 4, Omsk, Siberia.
NEWFOUNDLAND—W. B. Nicholson, Bank of Montreal Building, Water Street, St. John's. Cable address, Canadian.
NEW ZEALAND—W. A. Beddoe, Union Buildings, Customs Street, Auckland. Cable address, Canadian.
SOUTH AFRICA—W. J. Egan, Norwich Union Buildings, Cape Town. Cable address, Cantracon.
UNITED KINGDOM—Harrison Watson, 73 Basinghall Street, London, E.C., England. Cable address, Sleighting, London. N. D. Johnston, Sun Building, Clare Street, Bristol. Cable address, Canadian. J. E. Ray, Central House, Birmingham. Cable address, Canadian. J. Forsyth Smith, 27-28 Pearl Building, East Paradise, Leeds. Cable address, Canadian. F. A. C. Bickerike, Canada Chambers, 36 Spring Gardens, Manchester. Cable address, Cantracon. J. T. Lithgow, 87 Union Street, Glasgow, Scotland. Cable address, Cantracon.

SPECIAL TRADE COMMISSIONER—LUMBER

H. R. McMillan, visiting Europe, Africa, Australasia and the Orient.

CANADIAN COMMERCIAL AGENTS

AUSTRALIA—B. Millin, Exchange Building, Sydney, N.S.W.
BRITISH WEST INDIES—Edgar Tripp, Port of Spain, Trinidad. Cable address, Canadian. R. H. Curry, Nassau, Bahamas.
NORWAY AND DENMARK—C. E. Sontum Grubbedg No. 4, Christiania, Norway. Cable address, Sontums.

CANADIAN HIGH COMMISSIONER'S OFFICE

UNITED KINGDOM—W. L. Griffith, Secretary, 17 Victoria Street, London, S.W., England. Cable address, Dominion, London.

tained: 1 $\frac{1}{4}$ horse-power, \$78; 1 $\frac{1}{2}$ horse-power, \$55; 4 $\frac{1}{4}$ horse-power, \$95; 4 horse-power, \$180; 6 horse-power, \$185, \$215 and \$375; 8 horse-power, \$285.

Dealers also offer a complete plant for lighting and industrial purposes (the heating feature being superfluous for this climate), consisting of engine, motor and storage battery, with a capacity for 10 lights, costing at factory \$150, placed on market here at \$240. Others, of 20-light capacity, with a factory cost of \$200, sell here at \$320.

In this district pretentious residences warranting the installation of electric lights or farms where the development of power is desirable are very limited in number. Every important centre of population, including the sugar plantations, has service for both power and light, although it is probable that much of the current is available only during the "lighting" hours, from sunset to sunrise. In this city, however, it is stated that everything is in readiness for daily service except the running of the cable, the delivery of which has been delayed several months.



WAR PURCHASING COMMISSION

FOUR large volumes are comprised in the report of the War Purchasing Commission tabled in the House of Commons, Ottawa on January 23, and covering the work of that body from the time of its appointment, up to December 31st, 1916. Details of all accepted tenders in thousands of contracts are given along with all the Orders in Council relating to war purchases.

The commission is composed of Hon. A. E. Kemp, George F. Galt and H. Laporte. In a letter transmitting the report, Mr. Kemp says the duties of the commission include the supervision of purchases for the Canadian forces as well as the naval service and internment operations of clothing, equipment, munitions and supplies of every sort and the supervision of contracts for transportation. Purchases are made upon a tender or competitive basis. Inspection is carried out at the headquarters in Ottawa.

The rates charged for the transport of bodies of troops of 350 or more of all ranks for distances over 100 miles are one cent per mile second-class whether the railway company provides second-class accommodation or not, and one and a half cent per mile first-class. The rates for numbers fewer than 350 and for distances of 100 miles or less are one and a third cents per mile for second-class and two cents for first-class. The rates for freight are on a commodity basis of fourth-class on military equipment. For the transport of troops they are fixed by an agreement in connection with the sailing of each vessel these rates on an average being \$61 for officers and for other ranks varying from \$33.75 to \$36.25, according to the class of vessel.

INDUSTRIAL ^A_N^D CONSTRUCTION NEWS

Establishment or Enlargement of Factories, Mills, Power Plants, Etc.; Construction of Railways, Bridges, Etc.; Municipal Undertakings; Mining News

ENGINEERING

Toronto, Ont.—The Toronto Harbor Commission has started laying a track for the new industrial siding to the site of the proposed steel plant.

Toronto, Ont.—It is reported that an airplane factory, to cost \$200,000, is to be erected on nine and a half acres on the west side of Dufferin Street, north of Lappin Avenue.

Longueuil, Que.—The Standard Foundry on St. Elizabeth street, Longueuil, was the scene of a fire on Jan. 23. Most of the damage to the building and plant was due to water, and was estimated at about \$1,000.

Toronto, Ont.—The Toronto Harbor Commission is preparing the sixty-acre site recently purchased for the erection of the new steel plant for the Imperial Munition Board. A track has been laid and the pile drivers are ready to start operations.

Montreal, Que.—So far as known at the head office of the Canadian Car & Foundry Co., in Montreal the company has no intention of rebuilding on the site of the factory at Kingsland, N.J., destroyed by explosion and fire on January 11.

Preston, Ont.—The Town Council will consider submitting a by-law to the rate-payers authorizing a loan of \$75,000. Preston Car & Coach Co., or the endorsement by the corporation of a like amount of the company's bonds. The company sustained a loss of \$80,000 or \$90,000 over the above the insurance on account of the recent fire.

Owen Sound, Ont.—Following its incorporation, the new Nut, Bolt & Wire Co., is planning extensive alterations to the plant of the Nut & Bolt Co., which they absorbed. A new boilerhouse will be erected, a baking oven for annealing wire will be installed, and a wire cleaning house will be built. The new machinery is to be made in Owen Sound.

Trenton, Ont.—The British Chemical Co. have purchased an additional 36 acres of land, besides the 142 acres upon which they are erecting their plant here. It is said also that they have an option on two additional pieces of land of 41 acres and 80 acres. It is further stated that four hundred houses are to be erected the coming summer to accommodate the employees.

Minden, Ont.—Six miles north of Minden Village, on a property owned by Hugh Coulter, there is said to have been discovered a mining proposition that may prove of much value. Feldspar, magnetic iron and other minerals are said to have been found in large quantities. Also that a small piece of

the rock was smelted and turned out a fine sample of steel.

Three Rivers, Que.—The St. Maurice Paper Co.'s new paper mill, at Three Rivers with a capacity of 100 tons of newsprint a day, is now virtually complete, and should start operations in the next week or ten days. Concurrently with its construction, a 60-ton sulphite mill, and a 50-ton sulphate mill have also been going up. The entire new construction programme, supplementing the 100-ton mechanical wood pulp now operating, should be completed by about March.

ELECTRICAL

Brantford, Ont.—The wiring and equipment of the Western Counties Electric Co. in Brantford township

CANADIAN GOVERNMENT PURCHASING COMMISSION

The following gentlemen constitute the Commission appointed to make all purchases under the Dominion \$100,000,000 war appropriation:—George F. Galt, Winnipeg; Hormidas Laporte, Montreal; A. E. Kemp, Toronto. Thomas Hilliard is secretary, and the Commission headquarters are at Ottawa.

have been purchased by the township for \$4,000 and the Hydro-Electric Commission will now be asked to at once proceed with the extension of the system to Grandview, Parkdale and Echo Place, supplying also Hydro-electric light and power to township residents.

MUNICIPAL

Brantford, Ont.—The City Council are in the market for special castings required during 1917.

Fernie, B.C.—There is a coal shortage here, and unless supplies are received in a few days, the city power plant will be closed.

Calgary, Alta.—The Northwestern Engineering & Supply Co., has been granted a franchise to operate an electric light and power plant in Drumheller.

Montreal, Que.—The Board of Control will open tenders on February 9 for motor sweepers and street sprinklers, for which the sum of \$16,000 has been set aside in the 1917 budget. It was resolved that prices on the new machinery might be quoted by manufacturers as well as by agents.

Lindsay, Ont.—Tenders will be called in about two weeks for five pressure type mechanical filters for water purification. The total capacity of the filters will be 1,800,000 Imperial gallons per day. Bids will also be received at the same time for the erection of a filter house and an extension to the present pump house.

Sherbrooke, Que.—At the next meeting of the City Council a by-law, will be submitted to authorize the borrowing of \$500,000 for the purchase of the Two Miles Falls Power at Weedon, to develop the same and construct a transmission line to Sherbrooke. A report was made by Messrs. Francis & Co., Montreal, recently on the power. It was estimated that to fully develop the power and install equipment it would cost \$1,452,900.

GENERAL

Niagara Falls, Ont.—Damage to the extent of \$200,000 was done by fire on Jan. 27 to the American Cyanamid Co. factory.

Ford, Ont.—A new concern the Canadian Lamp & Stamping Co., contemplate building a factory here to cost \$27,000.

Fredericton, N.B.—A company is being organized here to manufacture cement products. W. C. E. Richard is interested in the enterprise.

Montreal, Que.—The shoe factory of Eugene Guay & Co., located in the rear of 230 St. Margaret street, was completely gutted by fire last Friday. Damage is estimated at about \$10,000, covered by insurance.

Tyndall, Man.—Fire on Jan. 23 destroyed the cut-stone plant owned by the Wallace Sandstone Quarries, located at Lvall near here. The loss is estimated at \$250,000.

Montreal, Que.—The factory of Jennings & Co., Wagon builders, 15 Wellington street, was the scene of a bad fire last Friday night. The Jennings Co., was engaged in the manufacture of trucks and ladders, which were destroyed, and the whole building was completely gutted, with a loss of about \$25,000, well covered with insurance.

Toronto, Ont.—The factory of the Channel Chemical Co., manufacturers of the "O' Cedar" mops and polishes at 369 Spadina Avenue, was badly damaged by fire last Thursday. The total loss is estimated at \$25,000, of which about \$20,000 is to the stock and the remaining \$5,000 to the building. The latter is owned by Robert Watson, and in both cases the loss is fully covered by insurance.

CONTRACTS

Winnipeg, Man.—The Greater Winnipeg District Board has decided to award the contract for the construction of ten miles of pipe line, at a cost of \$1,300,000, to the Winnipeg Aqueduct Construction Co. The matter, however, has not been finally settled, as other contractors have raised objections over the award.

Fredericton, N.B.—F. L. Boone, of St. Marys, has been awarded the contract for the construction of the D'Aigle Bridge, Madawaska County. The D'Aigle Bridge will be a 34-foot reinforced concrete span with stone embankment, and will be situated over Nine Mile Brook, near St. Leonards. The contract price is \$4,395.60.

BUILDINGS

Toronto, Ont.—Application has been made for permission to erect a \$200,000 aeroplane factory west of Dufferin street and north of Lappin avenue.

Toronto, Ont.—Application has been made at the City Architect's Department for permission to erect one section of the big \$15,000,000 departmental store. The section will be located at the corner of Yonge and College and will be 250 feet by 250 feet and fifteen stories high with basement and sub-basement. The height of the building from the cellar to the roof will be 316 feet and 280 feet above the kerb. The cubical capacity will be 19,750,000 feet and the construction will be of skeleton steel with terra cotta floors. Very little concrete will be used except for the foundations. The outside material will be of brick and stone. The cost is estimated at \$3,160,000. H. J. White Ryrie Building, Toronto is the architect.

TENDERS

Winnipeg, Man.—Tenders will be called until February 12, for works required for the completion of the new Parliament Buildings, which include the following:—Heating and ventilating, electric conduit and wiring. Thos. H. Johnson, Minister of Public Works, Winnipeg.

Winnipeg, Man.—Tenders will be received by R. D. Waugh, chairman of Commissioners, Greater Winnipeg Water District, up to February 5, for the supply of indicating and recording apparatus for two Venturi meters. Specifications may be obtained at the office of the district, 501 Tribune Building.

Ottawa, Ont.—Tenders for tungsten lamps, for the Departmental Buildings, Ottawa, Ont., will be received until Friday, February 2, 1917. Specification to be seen on application to the Clerk of Works, Postal Station "F," Toronto; to the Overseer, Dominion Buildings, Central Post Office, Montreal, and to the Chief Architect, Department of Public Works, Ottawa.

Montreal, Que.—Tenders, addressed to the Board of Commissioners, City Hall,

will be received until February 9, for the supply and delivery of auto sprinklers, flushers and auto sweepers. Copies and specifications and forms of tenders may be obtained by the interested parties at the office of the superintendent of purchases and sales, where all necessary information will be given.

Ottawa, Ont.—Tenders will be received at this office until February 12, for the supply of: Brooms and brushes, chain, coal, hardware, hose, oils and greases, packing, paint and paint oils, Manila rope, wire rope and steam pipe, valves and fittings, for the requirements of the departmental dredging plant in Ontario and Quebec during the fiscal year 1917-18. These forms of tender can be obtained at the Department of Public Works, Ottawa. R. C. Desrochers, secretary.

Winnipeg, Man.—Tenders will be received at the office of the Winnipeg Public School Board up to February 8, for supplying the following material:—Blacksmith's coal, drawing, hardware, iron, steel, lumber, oils, varnishes, electrical, printing, required in connection with the Technical and Manual Training Schools of the city. For specifications, forms of tender, and further information required, apply direct to the Commissioner of Supplies, School Board Offices, R. H. Smith, secretary-treasurer, W. P. S. B.

Toronto, Ont.—Tenders will be received up to Feb. 12, 1917, for the supply of the following materials for the Township of York, 24 in., 12 in., and smaller sizes, cast iron pipe; 24 in., 12 in., and smaller sizes of special castings; 6 in., 12 in., and 24 in. valves; air valves, hydrants, tops, covers and plugs, venturi meters and recorders; 6 in., 12 in., and 24 in. check valves. Plans and specifications may be obtained from Frank Barber, township engineer, 57 Adelaide Street West, Toronto.

RAILWAYS—BRIDGES

Winnipeg, Man.—The Greater Winnipeg Water District plant to operate an electric road between St. Boniface and Transecona.

Vancouver, B.C.—Work has started on the pile driving contract as a preliminary to the construction of the new C.N.R. station which will be built of reinforced concrete. There will be about 400 tons of reinforced steel used and about 10,000 cubic yards of concrete.

Niagara Falls, Ont.—The cantilever bridge owned by the M.C.R. is to be rebuilt, and work has already started. W. T. Tuttle, an engineer from New York, has arrived to take charge of the work. It will take eight months to build the new bridge, it is estimated, and meantime the present bridge will be used. It was opened in 1883.

Winnipeg, Man.—Application will be made at the present session of the Provincial Legislature on behalf of the Central Canada Railroad & Power Co. for an extension of the time for commencing and completing the construc-

tion of the railway authorized in 1905. The powers granted previously authorize the promoters to construct a railway from Winnipeg or St. Boniface to the northern limits of the province. The re-enactment of the act without amendment, as is planned, would extend the authority to the shores of Hudson bay, and would give J. D. McArthur and his associates the right to compete with the Dominion Government's Hudson Bay railway.

INCORPORATIONS

Capital Machinists & Founders, Ltd., of Ottawa have been incorporated with a capital of \$50,000.

The Canadian S. K. F. Co., has been incorporated at Ottawa with a capital of \$50,000 to manufacture and sell ball bearings and machinery at Toronto. The incorporators are Allan H. MacCaffray of Hartford Conn., also Percy O. G. Jones and James D. Beeking of Toronto.

The Mack Brick Co., has been incorporated at Ottawa with a capital of \$500,000 to manufacture brick and terra-cotta etc. The head office is at Montreal and the incorporators are Richard T. Heneker, Henry N. Chauvin and Harold E. Walker all of Montreal.

The Century Coal & Coke Co., has been incorporated at Ottawa with a capital of \$500,000 to carry on a coal business and to manufacture coke with head office at Montreal. The incorporators are Charles Murphy, Harold Fisher and Stanley G. Metcalfe all of Montreal.

The Huntley Mfg. Co., has been incorporated at Toronto with a capital of \$50,000 to carry on business as millwrights and to make mill and cannery machinery at Tillsonburg, Ont. The provisional directors are Charles G. Hammond and Leroy C. Hammond of Silver Creek, N.Y., also William H. Bennett of Tillsonburg, Ont.

PERSONAL

Duncan B. Ellis, a veteran Windsor lake captain, was knocked off the ear ferry and drowned on Jan. 22.

Lord Cowdray, head of Messrs. Pearson, contractors, and of the Mexican Oil Co., has been elevated to the rank of Viscount.

Captain John E. Tobin, a veteran of the Civil War, and for many years master of vessels, died at Windsor, Ont., on Jan. 22.

R. E. Speakman, city engineer of Brandon, Man., for the past nine years, passed away at Rochester, Minn., hospital on January 13, aged 70.

Sir George Foster is back in Ottawa from London where he attended the meeting of the Dominions Royal Commission drawing up the final report.

A. P. Hoag, for the past two months superintendent of the shell department of the Canadian Allis-Chalmers Co., Stratford, Ont., has been appointed superintendent of the Brantford Motors, Ltd., Brantford, Ont.

CANADIAN MACHINERY

AND MANUFACTURING NEWS

A weekly newspaper devoted to the machinery and manufacturing interests.

Vol. XVII.

TORONTO, FEBRUARY 8, 1917

No. 6

EDITORIAL CONTENTS

Manufacturing Gauges at a British Technical Institute	101-103
General	103-104
Hardening Steel on Falling Heats....Local Surface Hardening of Gear Teeth	
C.M.C. "First Aid" Installation....Recessing Tools for Special Work....Recovery of	
Lubricating Oils.	
Safe Practice at Blast Furnaces and its Development—II	105-109
Editorial Correspondence	110-112
Machinists' Instruction Course—XIII....Machining 4.5 in. Shell Cartridge Cases....	
Elevating Platform....Two Useful Kinks.	
General	112
Federal Government Expenditures.	
Spokes in Industry's Wheel	113
William J. McCallum.	
General	114
Machining Fly-Wheel on Automatic Turning Machine.... Chain Shells.	
Progress in New Equipment	115-116
Column Filing Machine Universal Flue Webber Akinoff Dynamic Balancing	
Machine.	
Editorial	117
Impaired Steel Production Capacity....Help to Win the War.	
Selected Market Quotations	118-119
The General Market Conditions and Tendencies	119-122
Toronto Letter....Montreal Letter....Canada's Last Fiscal Year Canada's New	
Borrowings Railway Material Prices Pulpwood Shortage Ontario Labor	
Branch Returns.	
Industrial and Construction News (Advertising Section)	58-65

THE MACLEAN PUBLISHING COMPANY, LIMITED

JOHN BAYNE MACLEAN, Pres. H. T. HUNTER, Vice-pres. H. V. TYRRELL, Gen. Man.

Publishers of Hardware and Metal, The Financial Post, MacLean's Magazine, Farmer's Magazine, Canadian Grocer, Dry Goods Review, Men's Wear Review, Printer and Publisher, Bookseller and Stationer, Canadian Machinery and Manufacturing News, The Power House, The Sanitary Engineer, Canadian Foundryman, Marine Engineering of Canada.

Cable Address: Macpubco, Toronto; Atabek, London, Eng.

ESTABLISHED 1887.

CANADIAN MACHINERY

AND MANUFACTURING NEWS

PETER BAIN, M.E., Editor. R. G. NEWTON, Manager.
Associate Editors: A. G. WEBSTER, J. M. WILSON, J. H. RODGERS.

CHIEF OFFICES:

CANADA—Montreal, 701-702 Eastern Townships Building; Toronto, 113-153 University Ave., Telephone Main 7321; Winnipeg, 22 Royal Bank Building, Telephone Garry 2313.

GREAT BRITAIN—LONDON, The MacLean Company of Great Britain, Limited, 88 Fleet Street, E.C., E. J. Dodd, Director, Telephone Central 42900. Cable Address: Atabek, London, England.

UNITED STATES—New York, R. B. Ince's, 115 Broadway, N.Y., Telephone Rector 8971; Boston, C. L. Merton, Room 733, Old South Building, Telephone Main 4201. A. H. Byrne, 1101 5-6-7 Fort Dearborn Bldg., 105 W. Monroe St., Chicago, Telephone Randolph 3231.

SUBSCRIPTION PRICE—Canada, Great Britain, South Africa and the West Indies, \$3.00 a year; United States, \$3.50 a year; other countries, \$4.00 a year; Single Copies, 15 cents. Invariably in advance.

Hendey Millers will take any kind of a miller job

that comes into the modern shop

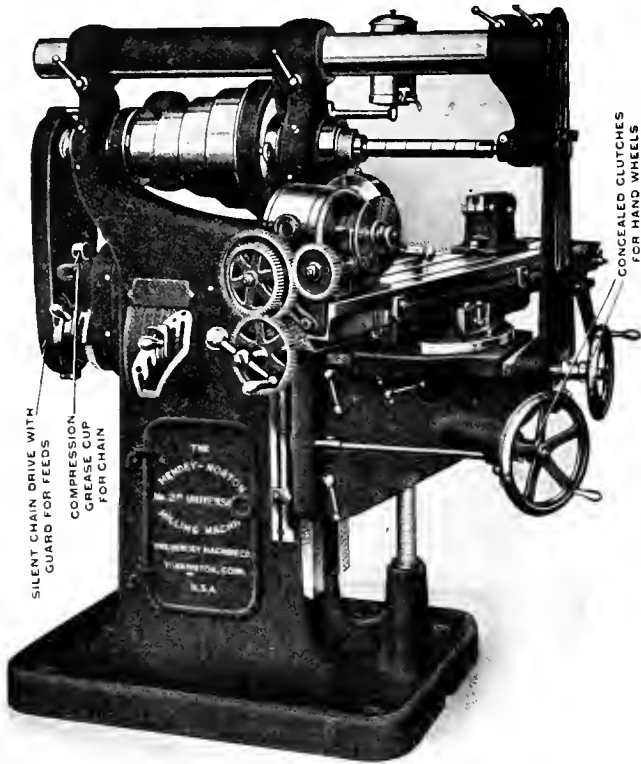

and it delivers the finished work in the highest degree of accuracy and perfection. It has a wide range of spindle speeds (16) and feeds (18).

The "Hendey" is free from the usual complicated features. All working positions are secured with but few and easily understood movements on the part of the operator. **Anyone can operate the "Hendey Miller."** No special skill is required to get the service that the Hendey's built for.

Write for the "Hendey Miller" Book. It is certain to interest you.

The Hendey Machine Co. Torrington, Conn., U.S.A.

Canadian Agents: A. R. Williams Machinery Co., Toronto, Ont.; A. R. Williams Machinery Co., 260 Princess St., Winnipeg; A. R. Williams Machinery Co., Vancouver; A. R. Williams Machinery Co., St. John, N.B.; Williams & Wilson, Montreal.

INDEX TO ADVERTISERS

<p>A</p> <p>Aeroplane Products, Ltd. 95</p> <p>Alkemade Howe, Co. 59</p> <p>Albany Pump Co. 84</p> <p>American Pulley Co. 14</p> <p>Armstrong Bros. Tool Co. 93</p> <p>Armstrong, Whitworth of Canada ... 7</p> <p>Atkins, Wm., & Co., Ltd. 13</p> <p>Atlas Crucible Steel Co. 16</p> <p>Aurora Tool Works 159</p> <p>B</p> <p>B.A.B. Model Mfg. Co. 78</p> <p>Babeock & Sons 64</p> <p>Baird Machine Co. 95</p> <p>Banfield, E. J. 24</p> <p>Banfield, W. H., & Sons 65</p> <p>Barnes, W. F., & John 84</p> <p>Barnes, Wallace, Co. 63</p> <p>Bertram, John, & Sons Co., Ltd. ... 1</p> <p>Biggs-Watterson Co. 67</p> <p>Blake Pump & Condenser Co. 81</p> <p>Bliss, E. W., Co. 59</p> <p>Brantford Oven & Rack Co. 62</p> <p>Bridgford Mach. Tool Works 5</p> <p>Bristol Company 92</p> <p>Brown, Boggs 26</p> <p>Brown Engineering Corp. 99</p> <p>Brown & Sharpe 69</p> <p>Brownell Machy, Co. 67 and 69</p> <p>Buhlen, Hanbury A. 64</p> <p>Butterfield & Co., Inc. 76</p> <p>C</p> <p>Canada Machinery Corporation ... Outside back cover</p> <p>Canada Metal Co. 88</p> <p>Canada Wire & Iron Goods Co. 62</p> <p>Can. B. K. Morton Co. 4</p> <p>Can. Fairbanks-Morse Co. 34</p> <p>Can. Bond Hanger & Compling Co. ... 81</p> <p>Can. Desmond-Stephan Mfg. Co. 101</p> <p>Can. Drawn Steel 93</p> <p>Can. Economic Lubricant Co. 87</p> <p>Can. Inspection & Testing Laboratories, Ltd. 93</p> <p>Can. Metal Products 93</p> <p>Can. Steel Foundries, Ltd. 7</p> <p>Can. Welding Works 103</p> <p>Carlyle Johnson Mach. Co. 85</p> <p>Chapman Double Ball Bearing Co. ... 87</p> <p>Cincinnati Pulley Machy, Co. 74</p> <p>Cook, Asa S. 92</p> <p>Corbet Foundry & Mach. Co. 18</p> <p>Cullen Machy, Co., C. W. 69</p> <p>Cummings, J. M., & Sons 169</p> <p>Cushman Chuck Co. 94</p> <p>D</p> <p>Dale-Brewster Mach. Co. 68</p> <p>Davenport Loco. Works 18</p> <p>Davis Torringtonville Co. 95</p> <p>Davis, W. F., Machine Tool Co. 6</p>	<p>Deloro Smelting & Refining Co. ... 6</p> <p>D'Mooy Mach. Co. 84</p> <p>Dept. of Finance 65, 95 and 107</p> <p>Dodge Mfg. Co. 83</p> <p>Dominion Forge & Stamping Co. ... 78</p> <p>Dominion Iron & Wrecking Co. 90</p> <p>Dominion Machinery Co. 23 and 68</p> <p>Dominion Steel Foundry Co. 93</p> <p>E</p> <p>Eastern Mach. Screw Corp. 74</p> <p>Elmes, Chas. F. 20</p> <p>Eric Foundry Co. 78</p> <p>F</p> <p>Fetherstonhaugh & Co. 64</p> <p>Fitzgerald, W. H. J. 69</p> <p>Ford-Smith Mach. Co. 89</p> <p>Foss & Hill Machy, Co. 1</p> <p>Foundry & Mach. Co. Inside back cover</p> <p>G</p> <p>Galt Mach. Screw Co. 69</p> <p>Gandner Machine Co. 95</p> <p>Gardner, Robt., & Sons 26</p> <p>Gatlock-Walker Machy, Co. 88</p> <p>Gavin Machine Co. 88</p> <p>Geometric Tool Co. 57</p> <p>Gilbert & Barker Mfg. Co. 73</p> <p>Gibb Instrument Co. 90</p> <p>Globe Machine & Stamping Co. 105</p> <p>Goady & Edmund 86</p> <p>Giant Gear Works, Inc. 96</p> <p>Giant Mfg. & Machine Co. 105</p> <p>H</p> <p>Hamilton Gear & Machine Co. 94</p> <p>Hamilton Machine Tool Works 23</p> <p>Hanna & Co., M. A. 19</p> <p>Hawkrige Bros. 63</p> <p>Hendey Machine Co. 112</p> <p>Hendrum, John T. 27</p> <p>Hoyt Metal Co. 96</p> <p>Hunter Saw & Machine Co. 64</p> <p>Hurlbut-Rogers Machinery Co. 84</p> <p>Hyde Engineering Works 74</p> <p>I</p> <p>Ideal Tool & Mfg. Co. 74</p> <p>Independent Pneumatic Tool Co. 61</p> <p>Illinois Tool Works 63</p> <p>Iron Works, The 63</p> <p>J</p> <p>Jacobs Mfg. Co. 93</p> <p>Jarline Co., A. B. 74</p> <p>Jencks Mach. Co. 95</p> <p>Jersey City Mach. Co. 95</p> <p>Johnson Mach. Co., Carlyle 85</p> <p>Joyce, Geo. A., Co. 93</p>	<p>K</p> <p>Kasensit, Ltd. 8</p> <p>KempSmith Mfg. Co. 89</p> <p>Kennedy, Wm., & Sons 24</p> <p>L</p> <p>L'Air Liquide Society 107</p> <p>Lancashire Dynamo & Motor Co. ... 67</p> <p>Lanlis Machine Co. 96</p> <p>Lewis Bros., Ltd. 9</p> <p>M</p> <p>Macnab, John, Machy, Co. 30</p> <p>Magnolia Metal Co. 93</p> <p>Main Belting Co. 87</p> <p>Marion & Marion 64</p> <p>Manufacturers Equipment Co. 76</p> <p>Marsh & Henthorn, Ltd. 80</p> <p>Matthews, Jas. H., & Co., Inc. 92</p> <p>McCabe, J. J. 12</p> <p>McCoy-Brandt Machy, Co. 69</p> <p>McDougall Co., H. Inside back cover</p> <p>McLaren, J. C., Belting Co. 94</p> <p>Mechanical Engineering Co. 103</p> <p>Metalwood Mfg. Co. 28</p> <p>Millers Falls Co. 30</p> <p>Millholland Co., W. K. 20</p> <p>Morton Tool Co. 30</p> <p>Modern Machy, Exchange 73</p> <p>Montreal Machy, & Supplies 82</p> <p>Morton Mfg. Co. 64</p> <p>Murchev Machine & Tool Co. 76</p> <p>N</p> <p>National Machine Tool Co. 95</p> <p>New Metal Tool Steel Co. 67</p> <p>New York Machinery Exchange 70</p> <p>Nicholson File Co. 101</p> <p>Niles-Bent- Pond, Inside front cover</p> <p>Noble & Westbrook Mfg. Co. 92</p> <p>Northern Crane Works 92</p> <p>Norton, A. O. 95</p> <p>Norton Co. 32</p> <p>Nova Scotia Steel & Coal Co. 8</p> <p>O</p> <p>Oven Equipment & Mfg. Co. 82</p> <p>P</p> <p>Parmenter & Bulloch Co. 96</p> <p>Perrin, Wm. R. 29</p> <p>Peerless Machine Co. 31</p> <p>Petrie, of Montreal, Ltd., H. W. ... 19</p> <p>Petrie, H. W., Ltd. 67</p> <p>Positive Clutch & Pulley Works 95</p> <p>Pratt & Whitney, Inside front cover</p> <p>Prent-O-Lite 109</p> <p>Pringle, R. E. T., Ltd. 33</p> <p>Puro Sanitary Drink'g Fountain Co. ... 63</p>	<p>R</p> <p>Racine Tool & Machine Co. 31</p> <p>Riverside Machy, Depot 63</p> <p>Rockford Drilling Machine Co. 82</p> <p>Roclofson Machine & Tool Co. 25</p> <p>Roper & Co., C. F. 86</p> <p>S</p> <p>Scott Mach. Co., G. H. 32</p> <p>Scott, F. H. 32</p> <p>Shore Instrument Co. 94</p> <p>Shuster Co., F. B. 93</p> <p>Simmons Mach. Co., Inc. 22 and 94</p> <p>Skinner Chuck Co. 22</p> <p>Slocum, Avram & Slocum 12</p> <p>Standard Alloys Co. 12</p> <p>Starrett Co., L. S. 91</p> <p>Steel Co., of Canada 3</p> <p>Steptoe, John, Co. 88</p> <p>Stocker, H. A., Machy, Co. 71</p> <p>Stow Mfg. Co. 99</p> <p>Strong & Hery Co. 72</p> <p>Swedish Gage Co., Inc. 79</p> <p>Swedish Steel & Importing Co. 79</p> <p>Symington, T. H. 14-15-16-17</p> <p>T</p> <p>Tabor Mfg. Co. 94</p> <p>Taylor Instrument Co. 90</p> <p>Toledo Machine & Tool Co. 29</p> <p>Tivani Electric Steel 92</p> <p>Toomey, Frank A. 70</p> <p>Toronto Iron Works 92</p> <p>Toronto Type Fdry. Co. 28</p> <p>U</p> <p>Union Tool Chest Works 95</p> <p>V</p> <p>Vanadium Alloys Steel 11</p> <p>Vulcan Crucible Steel Co. 8</p> <p>W</p> <p>Walcott Lathe Co. 32</p> <p>Webber Bros. Mach 62</p> <p>Wells Bros. Co., of Canada 33</p> <p>West Tire Setter 108</p> <p>Whiting Foundry Equipment Co. 28</p> <p>Williams, A. R., Machinery Co. 7 & 57</p> <p>Williams, J. H., & Co. 31</p> <p>Williams Tool Co. 105</p> <p>Williams & Wilson 66</p> <p>Windsor Mach. & Tool Works 65</p> <p>Winnipeg Gear & Engineering Co. ... 94</p> <p>Z</p> <p>Zenith Coal & Steel Products Co. ... 95</p> <p>Zin-Ho Mfg. Co. 89</p>
--	--	---	--

Manufacturing Gauges at a British Technical Institute*

By A. G. Cooke, M.A., W. J. Gow, A.R.C.S., and W. G. Tunncliffe**

Not because of any recognized merit or skill, but through their connection with the largest Technical Institute maintained by the largest Education Authority, the authors of this article have been honored with an important share in practical constructive work in the standardization of an engineering industry. The work dealt with includes workshop details and methods of securing a high degree of mechanical accuracy under conditions of great urgency

At the close of the session for evening classes in 1915, the personnel of the Mechanical Engineering Department of the L.C.C. Paddington Technical Institute was reduced to the Head, who, with the Principal, was continuing the engineering teaching of a Junior Technical School of 100 boys (14-16). Of the five permanent teachers of engineering, four had joined the Army and the fifth was "on loan" to a munition factory. From the elementary schools of the Council were transferred two metal-work instructors who had experience in gauge-making, Mr. W. G. Tunncliffe and Mr. H. C. Christie. Under their immediate direction were placed five other metal-work instructors and sixteen woodwork instructors.

Boys of the Junior Technical School in their second year were also employed; the ultimate arrangement adopted being for classes of about seventeen to work every third week for forty-four hours. Experience confirms that this is excellent in results, and worthy of consideration as a permanent system of engineering training.

Machinery that had been in ceaseless use by day and evening students for ten to a dozen years could hardly be expected to be ready for work of the highest accuracy. But no other was available. Practically for all but the "roughing-out" machines, complete reconstruction of those essential lathe parts on which precision depends was the first operation.

Nature of Manufacture

An explanation is necessary as to the nature of the work undertaken, and its place in relation to the whole industry. The precision desired for primary standards for laboratory testing is limited by practical possibilities only, and the manufacture is not a "commercial proposition." Inspection gauges, or secondary standards, are to be manufactured within a determined though small range of variation or "tolerance." This tolerance should be regarded as a definition, not an error limit. Within the tolerance all values are "correct." In

consequence, the manufacture is entirely a question of competitive cost and urgency of delivery.

That standardization is the key to efficient manufacture and a large output is universally recognized. It is not so well understood that simply on account of the magnitude of the output, apart from the question of excellency of workmanship required, the necessity for standards of a higher order of accuracy arises. It is easy in a small workshop to insure by trial that all fitting is satisfactory; in fact, the initial magnitudes are generally determined by the same tools and standards. In a larger workshop the work is linked by more accurate gauges; and it generally matters little if the absolute measurements vary appreciably from that specified in the design. But when an industry grows to a national or international extent, the standards must aim at specified dimensions of absolute magnitude, defining exactly the limits of permissible variation on either side of the standard, so as to include all acceptable, and reject all unacceptable variations from the correct value. In the language of the calculus in order to limit variations to a defined "small quantity," inspection gauges are

were manufactured, the essential difference being that the former must be adjusted to be within the specified limits, while any tolerance permissible in the latter must be outside, so as to pass all acceptable work. Tolerance in a workshop gauge tends only to increase the margin of safety, enforcing greater care in manufacture than necessity demands. Uncertainty and variation in inspection gauges is not only unjust to one manufacturer, but affects all by necessitating closer limits.

The necessary order of accuracy for this type of gauge, three ten-thousandths is generally specified, can be obtained with universal grinders. As the demand was urgent, and grinding machinery not available, they had to resort to hand-work. Lapping with high-speed motors up to three or four thousand revolutions, and other devices for acceleration, were developed.

Position-Gauges

The greater part of the work entrusted to this Institute consisted of a class of gauges determining position or some geometrical feature, involving greater difficulties in theory and practice than a single directly measured dimension.

Concentricity, perpendicularity, or parallelism, and distance between centres of turning and drilling, are examples. The authors are unfortunately unable to give details, but it will be seen that to determine some such geometrical conditions, or primary measurements, in the work to be tested, limits of accuracy are allowed by a definite variation in the size of diameters of cylinders, pins, or drilling, so as to allow slackness. The gauge limits the combined errors in jig or automatic tool work.

It will be seen that any variation of the inspection gauge, as regards the primary condition, simply displaces the limits which it is intended to give, rejecting satisfactory and accepting unsatisfactory work through a range of double its own error. The practice is to allow a gauge tolerance of only 0.0001 in the primary measurement, and a combined tolerance of 0.0003.

Screw Gauges

The methods by which they attained the high accuracy required for screw-gauges are selected for special description. They try to limit any discission

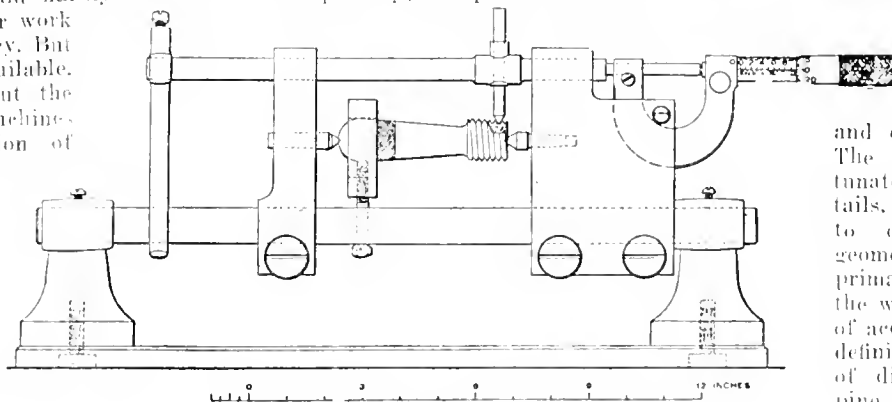

FIG. 1. APPARATUS FOR PITCH MEASUREMENT.

required to be true to the "second order of small quantities." It is just in so far as we can rely on the accuracy of inspection gauges to define the limits of variation permissible, that the designer can allow those limits to be extended with safety. Hence the apparent paradox that high accuracy in the inspection gauges allows more laxity, and so increases facility and speed of manufacture.

Limit-Gauges

There is no need to describe in detail the principles of limit-gauges for measurements of length and diameters. Both workshop and inspection gauges

*Read before the Institution of Mechanical Engineers, London, Jan., 1917.

**London County Council, Paddington Technical Institute.

of scientific principles to such as directly affect their work in the construction of the gauges. In screw-gauges the gauging surface is an elaborate skew surface, all parts of which are required to be within the limits, in general fixed at three ten-thousandths measured radially from the axis [0.0006 in diameter]. This means only about 1½ ten-thousandths normally to the slope of the threads. It must not be forgotten that this is the second order of small quantities necessary to define a larger variation permissible in the work. As a variation of which this is 5 per cent. would allow a sheet of the *Times* newspaper to be used as packing (three thousandths), it cannot be regarded as too fine.

for this not only the amplitude but the length of the periods must be considered, and probably also the method of lapping. Short periods and lapping with high speeds through several turns of the lap seemed necessary to success.

Workshop Measurements

It was found absolutely necessary to design and make for themselves instruments by which measurements of pitch and the diameters of the screw-gauges could be made on the premises, and optical apparatus by which screw-cutting tools could be shaped and the sections of the screw-threads examined. Details of these may perhaps be of interest, not as examples of high accuracy of physical measurement, but of practical methods suitable to the workshop.

and final pitch diagrams of test-pieces from the same lathe before and after correction. The test of Fig. 3 was taken on opposite sides of a test-piece of fourteen threads to the inch, the leading screw-pitch being presumed four threads to the inch. Analysed, it shows a fairly uniform progressive error of 0.0022 per inch, with superimposed periodic errors corresponding to the revolution of the leading screw, of amplitude 0.0004 inch. The lathe was in good condition, fairly typical of ordinary workshop accuracy.

Two methods of correction for progressive error were considered:—

(a) By accelerating the motion of the top slide of the compound rest by means of a weighted lever attached to the screw. The screw of the slide was turned at a uniform rate as the saddle traversed along the bed of the lathe, by making the end of the

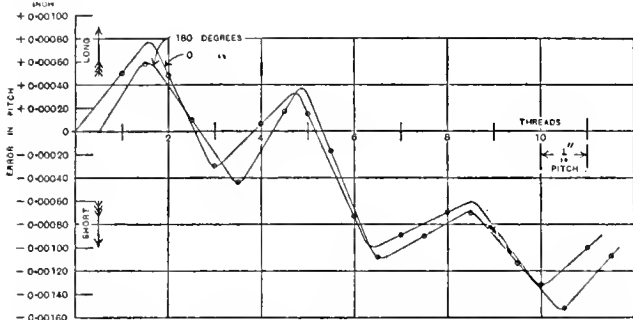

FIG. 2. TESTS TAKEN ON OPPOSITE SIDES OF A TEST PIECE OF 14 THREADS PER INCH; LEADING SCREW PITCH, 4 THREADS PER INCH.

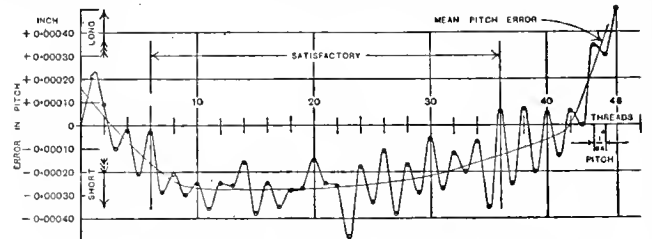

FIG. 3. FINAL TEST ON A SCREW SHOWING A SATISFACTORY RANGE FOR A LENGTH OF 1¼ INCHES.

It should be evident that the accuracy in pitch of the lathe used should be such that no divergency from the correct value greater than about 1½ ten-thousandths should exist throughout the range used. For this would cause a skew surface otherwise cut in correct shape to the mean value to pass outside the limits allowed. If any further error in pitch exists, up to an extreme value of three ten-thousandths, it is only possible to keep within limits by thinning of threads, reducing the effective diameter, and the practical difficulties of the reduced margin increase rapidly if the above error is exceeded. The authors found that the lathes by a number of manufacturers showed an error in pitch of about two in a thousand, always short of specification. This uniform or progressive error is fairly easily corrected by change of gear-wheels, as will be shown by an example, but indicates the lamentable need for standardization in leading screws. Superimposed on this error were periodic errors, initial and produced by wear, requiring measurement, analysis and correction. It is desirable to repeat that they are aiming not at perfection, but a precision defined by tolerance. In a choice between methods of correction, that which will permanently rectify a discovered cause of variation so as to bring it within the defined limits, is infinitely preferable to any method of compensation which, though more capable of refinement, would allow redevelopment of error in prolonged heavy use, thus delaying output.

The periodic error is amenable to reduction by a final lapping process, but

The apparatus for pitch measurement is shown in Fig. 1. By its use on test-pieces they were enabled to analyse step by step the errors of pitch in lathes. One example will be given in some detail. The pin, which is moved from groove to groove, followed by micrometer, is turned to a cone of angle slightly less than 55°, and the point removed to insure that the pin touches not the bottom, but the sides of the groove. Supreme care, by good fitting, is necessary to insure that the points of contact follow a line parallel to the axis of the screw.

The differences between the microm-

lever down an inclined plane, the slope of which could be readily determined from the known pitch error.

(b) By selecting a new train of wheels, a process demanding some considerable calculation by trial and error for different pitches, but which has proved quite possible in all cases. For example, the train of wheels, drivers thirty-eight and twenty, followers ninety-one and fifty, gives a pitch of twenty-four to the inch correct to less than 0.000007.

The periodic errors corresponding to the revolution of the leading screw may be due to:—

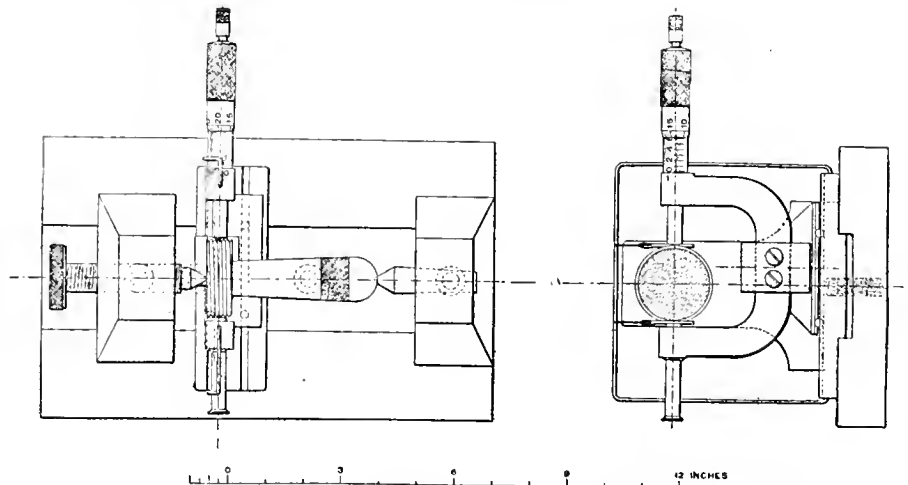

FIG. 4. APPARATUS FOR EFFECTIVE DIAMETER MEASUREMENT.

eter readings for each groove, and those calculated for a correct screw of the presumed pitch, are plotted as ordinates in Figs. 2 and 3. These are selected from a large store of records as the first

(1) Reproduction of an error in the leading screw.

(2) An axial movement of the leading screw with each rotation, owing to both

the thrust collar and bearing being out of truth.

(3) Lack of straightness or stiffness in the leading screw causing oscillations at the point of contact of the nut.

To correct (2), the collar bearing on the leading screw was dispensed with, and the thrust was carried by a single ball-bearing applied to an enlarged centre on the leading screw. The collar was turned off and the screw made to run free in its bearing. A half-inch ball was used, and the thrust taken by a bolt screwed through a bracket, and locked in position, the end of the bolt being made intensely hard.

After testing and correcting the change-wheels for eccentricity, it became evident that a more accurate and rigid leading screw was necessary. A new leading screw was cut on the milling machine on a sleeve of 2 inches diameter and 8 inches in length, with a pitch intended to be twelve threads to the inch. A split nut $2\frac{1}{4}$ inches in length was clamped by a weighted lever mounted on the original leading screw as shaft a progressive error of 0.0008 was found, with a periodic error amplitude nearly 0.0003. On substituting a short stiff shaft the latter was reduced to an amount not exceeding 0.0002, which may be considered satisfactory. The progressive error was approximately corrected by the following gear-wheels:—

- For 24 threads to the inch
45×30 Drivers.
- 38×71 Followers.
- For 14 threads to the inch
36×67 Drivers.
- 74×38 Followers.

The final test showing a satisfactory range for a length of $1\frac{1}{4}$ inches is shown in Fig. 3. This length, carefully marked, was sufficient for the gauges required.

The apparatus for effective diameter measurement is shown in Fig. 4. The micrometer carriage, mounted on balls, is constrained to move in a plane at right angles to the axis of the screw to be tested. This apparatus may also be used for measuring core diameter, by using triangular prisms in place of the small cylinders.

An ordinary 0 to 2 inches micrometer, fitted with a special adjustable attachment to enable direct measurements to be made of core diameter, is shown in Fig. 5.

Optical Projection

Enlargement by optical projection was first resorted to for adjustment of the shape of tools for screw-cutting, and verification of the shape of thread. Finding the possibilities for accuracy of measurement were greater than was thought possible, and well within tolerance allowed, the use was extended to a large variety of gauges, particularly to plate gauges of shape, slots and holes, curvature and cone angles, etc.

The key to the method is to secure, as nearly as possible, a truly parallel

beam of intense light, freed from heat rays by passage through a saturated solution of alum. An optical bench of great rigidity, and sensitive and universal adjustments, carries the gauge or tool and projecting lenses. The screen is at a distance of about 16 feet.

The necessity of a parallel beam (except for tool edges) should be obvious in dealing with gauging surfaces, such as plates and screw-threads, and adjustment for tangential or grazing incidence must be as fine as possible. This limits the field for simultaneous survey to that of the area of the projecting lens. A combination of three optical elements was designed to give variable magnifica-

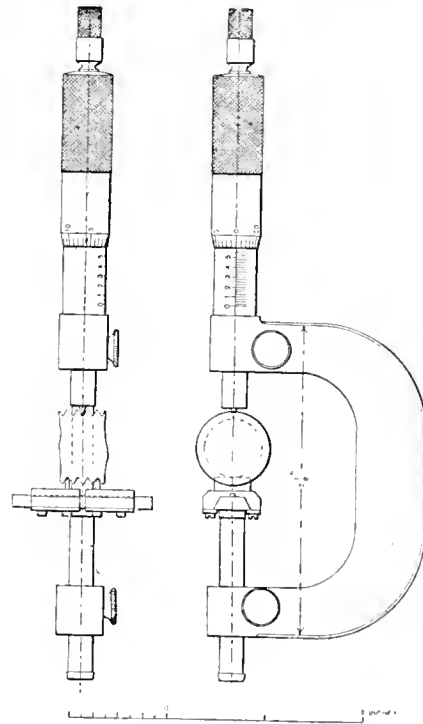

FIG. 5. APPARATUS FOR CORE DIAMETER MEASUREMENT.

tion up to 400. About 180 is, however, ample, and visible in undarkened room. Where it was desired, as in a few cases, to cover a larger gauge length than about half an inch, a triple achromatic lens of 2 inches diameter and 6 inches focus, was combined with an astigmatic lens. The area surveyed on this extended up to over $1\frac{1}{2}$ inches, with fifty magnifications on a 6 feet screen. Quick interchange of gauges and tools from optical bench to vise or lapping motor with the minimum of readjustment is essential.

Shaping of Screw-Threads

With a magnification of 166 a clear definition of the working edge of the single-pointed tool for screw-cutting is possible to much less than a ten-thousandth, this being represented by one-sixtieth on the screen. The angle and rounding off of the nose for the required pitch are adjusted with a fine oilstone to this degree of accuracy, after hardening without tempering, and quickly readjusted after wear. The same tool is used to cut the groove in a capping tool

for the crests. It is then possible to insure correct shape, provided that the relation of core to effective diameter is checked by measurement.

In the final projection of the screw-thread in silhouette, a careful examination for symmetry is advisable, checking the setting of the tool. A small margin in all dimensions is left for lapping, which removes some residual errors, the margin being increased if a hardened gauge is required. For rapid lapping the screw-gauge is held in a self-centring chuck on the shaft of a 1 horse-power electric motor. This is automatically controlled by a reversing switch, so that it rotates with precision, uniform torque, and any desired speed, two revolutions forward and backward.

The laps are made of cast iron, cut with a tap, or on lathe, split, and adjustable for wear. Frequent retapping retains the shape. For the core a lap is prepared with a slightly thin thread, and for effective diameter a full thread with crest removed.



HARDENING STEEL ON FALLING HEATS

MANY misleading ideas are current with regard to the correct method of hardening steel. For instance, one group of theorists advocate that the metal should be heated just through the critical range, and then cooled suddenly, whilst the temperature is still rising. This method, they state, confers the finest possible structure to the material. Moreover, unfortunately, many practical steel hardeners think that it is absolutely essential to quench the metal from the highest heat attained, and, accordingly, this method of procedure is the one largely followed in works practice. Herein lies the cause of a large percentage of hardening cracks. Let it be firmly impressed in the mind of the operator that quenching should always be done on a falling heat, otherwise the object is almost certain to crack in the bath. The falling heat permits the object to contract before it is put into the bath, and, in consequence, greatly reduces the risk of cracking and distortion. Once the material has been correctly heated to the hardening temperature the heat may be allowed to fall considerably before quenching, without in the least affecting the hardness of the quenched object. Experiments over a range of steels show that the temperature may be allowed to fall as much as 100° C. without showing a material reduction in the hardness. Practical Engineer.



LOCAL SURFACE HARDENING OF GEAR TEETH

AN English process, reported to be largely used for hardening gear teeth, is known as the Vickers. It is local surface hardening and consists in applying momentarily to the surface of the part to be treated an intensely hot flame from an oxy-acetylene blow pipe. The surface, having been raised to a high temperature, is quenched by the cold

body of the metal beneath. The equipment is that usually provided for oxy-acetylene welding, but the temperature of the flame is higher, the increase being obtained by adjusting the flame as for welding and then increasing slightly the supply of oxygen. The body of the work must be kept as cool as possible, to insure that the quenching is sufficiently rapid. For small parts it is customary to immerse them in cold water. Bodies of large parts may be left to cool off by themselves, but where necessary a supply of cold water may be allowed to flow over the work. In both cases the actual surface to be hardened is not to be submerged in water unless it is desired to give only a very shallow depth of hardened crust. In calculating the cost, for the purpose of comparison with furnace-treated work, it is pointed out that while for the latter process machining is carried out to approximate dimensions only, so that any distortion due to the heat treatment may be corrected by grinding and straightening, in the local surface-hardening process the work is machined to the finished dimensions, since no distortion is caused.

C.M.C. "FIRST AID" INSTALLATION

THE Canada Machinery Corporation, of Galt, Ont., have recently installed a "First Aid" Dressing Room at their plant, a further indication of the progressive policy being pursued and developed by the management.

The room, which is in every respect a modern hospital, is conveniently located in the centre of the works and is finished entirely in white enamel, having excellent artificial and natural lighting. The selection of the equipment was done under the advice of Dr. D. Buchanan, the shop Benefit Society physician, and in part consists of a steel white enamelled dressing table with glass shelves; a steel white enamelled dressing chair with adjustable arm and head rests and dressing basin; a large white enamelled dressing table with leather cushions and adjustable head and foot rests; a stretcher for use in the case of serious accidents; a large white enamelled cupboard containing various bandages, antiseptics, dressings, etc., and a special case of instruments for the use of the doctor in case he is called suddenly to the factory. Running hot and cold water are also available at a large wash basin.

In the treatment of accidents, all of the work does not fall upon the shop physician, for in each department are two qualified first aid men who have charge of accidents which may occur in their particular part of the works. This first aid dressing room is not a requirement of the Workmen's Compensation Act, the company taking the step in the interests of the employees and to make working conditions as nearly perfect as possible.

RECESSING TOOLS FOR SPECIAL WORK

Herbert's Monthly.

When a recess has to be cut at the bottom of a deep hole, the standard forms

of recessing tool holder and cutter are unsuitable, for the cutter would stand out so far from the holder that it would chatter badly; similarly if the work stands a long way from the chuck chattering is also likely to occur, even if the recess is not far from the mouth of the hole. In cases such as these it is necessary to employ a method of recessing which ties up the recessing tool to the work; a good example of a tool of this type is shown in Fig. 1. The body of the tool holder is bored to receive a sleeve with an eccentric hole. In this eccentric hole there is a cutter spindle which can be rotated through about 90 degs. by means of the knurled handle; it will be seen that by doing this, the cutting tool is advanced from the centre by a distance limited by stops.

In Fig. 1, the work being recessed is an 18-pounder high explosive shell, and the revolving bush on the front of the sleeve fits in the bore previous to threading, and thus ties up the tool to the

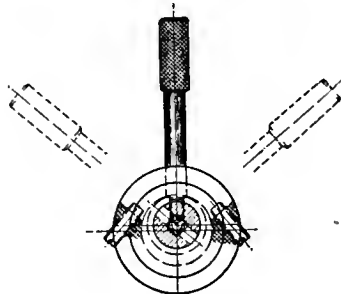
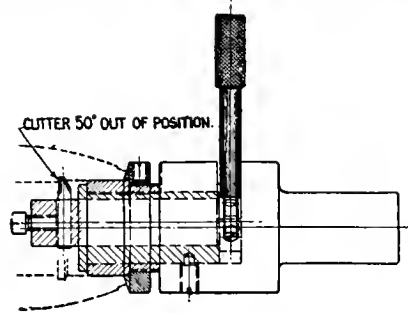

FIG. 1.

work. An adjustable collar is fitted on the revolving bush which butts up against the fuse seat of the shell and determines the distance of the recess from the front. On holes too small to use a revolving bush the sleeve may fit directly in the hole being recessed, and it is important to note that the sleeve should, therefore, be hardened.

A good type of recessing tool for work in which the recess is near the front of the hole is shown in Fig. 2, and consists of a shank to which is fitted a sliding portion which can travel at 40 deg. to the axis of the spindle. This front sliding portion is bored to receive an ordinary circular recessing cutter, and at the front of the hole there is a hardened plate which can butt up against the work. The slide is kept in its normal position by a spring, and, when the turret is advanced towards the work, the front slide is arrested by the hardened plate which stops against the work, and, as the turret still advances, the recessing cutter travels across the

axis of the lathe until the recess has been cut to the required depth, this being limited by the distance to which the turret is advanced. As this type of recessing slide requires a feed in one direction only, it is very suitable for use on automatics, on which it has been largely used.—Herbert's Monthly.

RECOVERY OF LUBRICATING OILS

LARGE quantities of oil are used in all machine installations, for lubricating purposes, and though the amount actually required to effect efficient lubricating is relatively small in each case, considerable excess is, for one reason or another, generally employed. For the sake of cleanliness, catch pans or grooves are provided to receive all oil working through bearings, so that the excess oil, mixed with dust and dirt, and usually "worn" to a more or less insignificant extent, is available for re-use, providing it be first cleansed. Machines for this purpose are to be had, but some of these require much attention in order to maintain satisfactory results, and cannot in any case be applied to thick cylinder

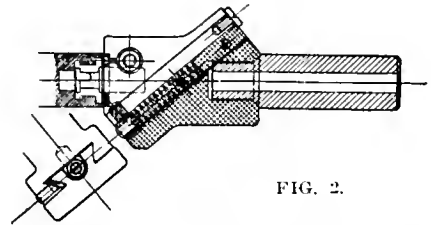

FIG. 2.

oils and similar lubricants. The demand for a simple means of cleansing oils rapidly and economically is perhaps best met by centrifugal separators.

With more or less unimportant distinctions between individual makes, these machines comprise a conical whirling receptacle keyed on to a shaft and rotated at high speed within a stationary cast-iron drum. Oil to be cleansed is placed in a container within the whirling frame, and the latter is set in motion. Centrifugal force drives the oil up the smooth walls of the container to the rim, and hurls it thence through a fine brass gauze screen, which removes light foreign material carried up with the oil; heavy impurities remain at the bottom of the rotating vessel. In large installations it is preferable to employ separate machines to remove heavy particles from oil, and to clarify the latter completely. Purified oil may be conveniently compared with new oil by smearing a drop of each side by side on a sheet of clean paper. When the latter is held to the light, any suspended particles of muddiness in the separated oil will be easily detected.

C. G. Railways Appropriation.—The Canadian Government Railways call for an increased appropriation of \$11,150,000 for working expenses. In the post office mail service there is a reduction of \$200,000, but there is a long list of increases in the outside service of the Post Office Department. The vote for rural mail services is cut by \$200,000.

Safe Practice at Blast Furnaces and Its Development--I.

By Frederick H. Willcox

In its efforts to increase safety in the metallurgical industries, the Bureau of Mines, Washington, D.C., has been studying the causes of accidents at blast furnace plants also methods for their prevention. This article describes the known dangers and makes suggestion of means whereby the risk of accident may be lessened or, better still, wholly avoided.

THE CAST-HOUSE CREW

LABORERS and new men should be made acquainted with the possibilities of slips, gas, breakouts, and bursting tuyeres. If you can show them how to be less clumsy in handling tools do so, because awkward men may injure others as well as themselves. If you see anyone doing something that is dangerous or standing in some place where he might get hurt, tell him of the danger. If a man's clothes catch on fire, do not let him run. Put the fire out with a hose, or roll him in sand and smother the fire by throwing sand on it, or wrap him in a blanket or coat. If a man is gassed or receives an electric shock get him into fresh air, notify the foreman, and give him artificial respiration at once; loosen his clothing, take any tobacco out of his mouth, and keep him warm.

Operators' Clothing

Always wear clothes made of wool or hard jean cloth if possible, and especially avoid greasy clothes, as they will readily catch fire. Wear stout shoes, having thick soles, and without cracks or holes, that are not too low, and fit tightly about the leg (see Fig. 12). Congress shoes and leggings are advisable. Wear goggles or a mask to prevent injury when handling hot metal or cinder, breaking scrap with sledges, or turning hose on hot material. Never wear ordinary gloves or hand-made hand leathers in handling jagged pieces of scrap. Leathers or gloves with a safety spring in the back are the only safe ones, as the scrap will frequently catch the glove or leather and may cause a serious sprain or fall.

When breaking runner scrap, slag, lumber, test pieces, etc., with sledges or a "Mulligan," use judgment in blocking up the pieces before breaking them. The closer the material is to the floor, the less probability there is that it will fly in breaking. When barring scrap, plates, or other objects, be sure that the point of the bar is firmly engaged, or that the bar will not slip off the block, before you lift or put your weight on the bar. Keep your working place cleaned up. Bars, drills, and long-handled tools should be kept where they will not fall and injure anyone, by preference in a tool rack. If they are leaned against the wall, place them so they can not easily be knocked over or fall down. Don't leave tools where men can stumble over them. Remove burned drills and bars promptly. Watch out for hot bars and don't throw bars without looking to see whether some one may be hurt by their rebounding. Be

careful when the cast house is full of steam; feel your way, do not attempt to go quickly.

When a blast furnace is being blown in or blown out, banked, stopped for a time, or started up, it is more dangerous than in regular running. At such times do not rely upon your own knowledge of furnaces, but follow every direction of the foreman strictly. Do not do any of the routine duties about the stoves, dust



FIG. 12. CAST HOUSE MAN WEARING LEGGINGS, GOGGLES, FELT HAT, AND WOOLLEN SHIRT.

catcher, bleeder, cinder notch, tapping hole, or tuyeres except by direction of the foreman or blower. Don't go on the bustle pipe unless you notify the stove tender, keeper, or blower. When you have to work where you can smell gas, take frequent spells in fresh air and work with another man. Do not stay where there is gas unless your foreman knows conditions and that you are there.

Miscellaneous Precautions

Do not rest or stand under, near, or in front of blowpipes or tuyères, as they may burst or burn through, and throw metal, cinder, coke, or gas over you. When you know that the furnace is hanging, keep under cover and warn others. Keep away from the bottom of dust catchers, stove burners, downlegs, and manholes of underground flues at such times. In going to and from work avoid going under cranes carrying loads or under skip inclines, or through stock houses, boiler rooms, or places where you are unfamiliar with the work done there.

Do not try to do work other than your own about the furnace unless you are familiar with the work or have been ordered to do it. Especially do not try to help the hot-blast man on shutdowns or on work with the bleeder, mixer valve, or any regulating part of gas or blast mains unless everything you do is specifically directed by him. Many accidents have been caused by misunderstanding what some one else was doing.

Avoid Foolhardiness

Always use every safeguard provided—goggles, masks, shields, safety hand leathers, tongs, and gloves. (See January 25 issue, Figs. 6, 7, and 12.) They are provided to prevent injury to yourself, and men at other plants use them. Refusing to use them is not a sign of bravery or of familiarity with your work, but rather of foolhardiness and ignorance of the danger.

Do not drive the tapping bar through the skull in the tapping hole, or go on the last spell on the drill before you have placed the splasher and put a shield in front of the tapping hole, or a cover plate or sheets over the trough, in front of the splasher. (See Figs. 13 and 14), except under unusual circumstances. When it is necessary to pull the tapping bar out don't hold on to the "welshman." Lay a bar across the runner to support the tapping bar while driving it out; the molten iron may rush out unexpectedly and burn you.

Do not stand in front of the iron notch when opening it; work from the side as much as possible, even on the first spell, and keep your feet out of the trough. Be especially careful when working on a short, green, hard or an unusually long hole. On changing turn, the keeper going off duty should inform the one coming on as to the condition of the tapping hole. If the hole has been working short or badly, and has not been taking the clay, the keeper should inform the other keeper and tell him how much clay was used on the last stop.

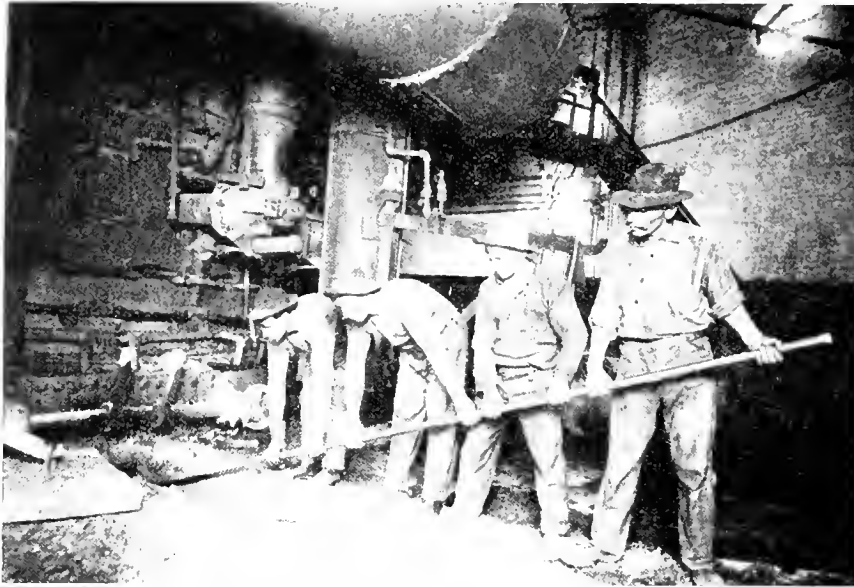

FIG. 13. UNSAFE METHOD OF DRILLING A TAPPING HOLE.

Men standing over open trough on planks, no shield used at tapping hole, men wearing loose, baggy clothing.

Do not cast until the skimmer, trough, runners, shutters, and spouts are dry and warm. Clay, sand, loam, or coke dust in the runners must be dry to avoid "boils" of molten iron. Do not leave pieces of cold scrap in the runners or place damp sand against the shutters or gates. Don't let pieces of wood get under the skimmer dam or drain gates, and bank up the drain or "punch-out" gates on the outside with dry sand. In filling the mud gun before a cast, only one man should do the work if the clay is being fed at the funnel, because if two men are used, one to operate the plunger and one to feed the clay, one of them may be caught by the plunger.

Loading Clay

In loading clay at the funnel do not

push it down with your foot; use a stick. However, the gun can be loaded as well and more safely by putting the clay in at the nose of the gun with a rammer. When the gun is loaded, put about 3 inches of dry sand or ground ganister mixed with tar or black oil in the nose, removing enough clay to give room. Wet or sloppy clay may cause an explosion when it comes in contact with hot iron. Do not wet the nozzle of the mud gun. Daub it with black oil after casting, while it is still warm, and again just at cast time. This will keep it from getting wet, and will prevent a "shot" if the nose of the gun is placed in the hole against a stream of molten iron. Oiling the nose of the gun is better than warming it, because if the nose is heated too

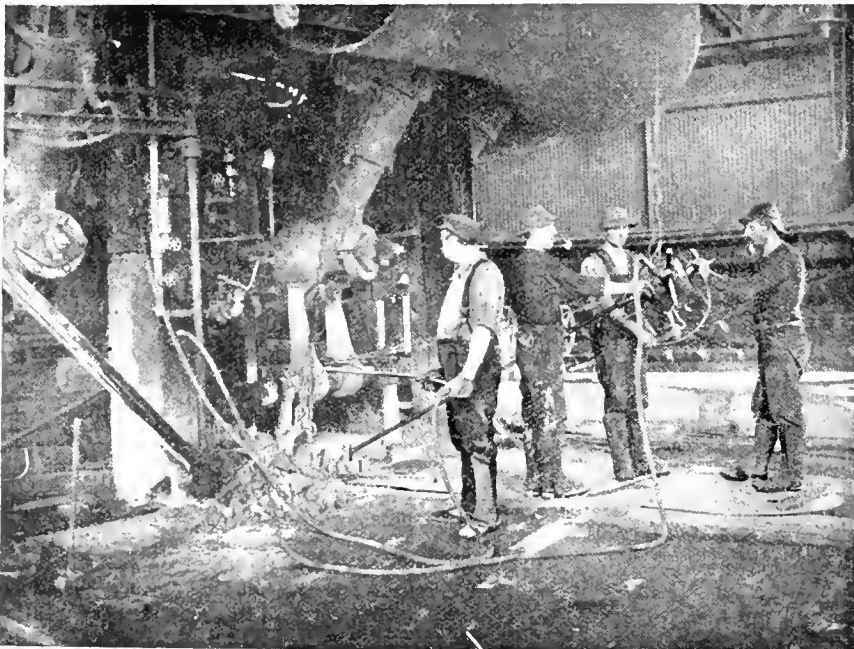

FIG. 14. SAFE METHOD OF DRILLING A TAPPING HOLE.

Steel plate over runner, shield in point of tapping hole, men wearing proper clothing, air jet used to clean tapping hole.

much or too long the clay will become dry and stiff, and may cause a short hole. If heating the nose is preferred, pouring one or two hand ladles of cinder over it should be sufficient.

When casting do not use cold or wet bars to poke out sand, clay, or loam in the runners or gates or to break a path for the iron. Lift the punch-out or drain gate (Fig. 15) slowly, to avoid a rush of iron, which may cause boiling, and be sure the punch-out bar is warm. Before turning the iron into a ladle see that the ladle is spotted and is all right. Do not fill the ladle within more than 8 or 9 inches of the top, as the iron may be spilled in shifting it. Do not throw large pieces of cold scrap into the ladle before or during the cast, as it may cause boiling or an explosion of the hot metal. It is safer to fill the ladle nearest the furnace first and finish the cast in the ladles at the lower end, for several reasons. One reason is that the gates may be lifted quickly and the operator go away instantly. (See Fig. 16.)

If the iron is run to the bottom ladle first, be sure that all shutters are dry; if to the top ladle first, be especially sure the sand at the gates is dry. When using the pricking rod on an obstruction in the tapping hole, do not throw too much weight on the rod if standing close to the trough. Be sure that the hand ladles and chills for samples or pig-machine wheels are dry. Do not cross iron or cinder runners during a cast except when necessary, and watch your step very carefully; if you have to go in front of the iron notch, get across quickly. Do not step on the crust of hot cinder. Do not flip wet clay into hot iron to annoy or tease a fellow-workman—it is too dangerous.

Stopping the Tapping Hole

In stopping the tapping hole, be cautious when placing the mud gun in the hole. Unless the cinder and iron in the trough lays away from the hole, drain the trough before putting the gun in. Do not put the gun in the hole against a stream of iron unless the nose is warm and dry, as the iron may explode. After the gun is clamped, turn the steam on by the valve at the column, or by means of a long hook open the three-way cock on the gun. There is danger of gas bursting out or cinder being thrown back when the first clay is shot in. Care must be exercised in stopping the hole after the first shot, as the pressure in the furnace and the suction of the plunger may throw the clay back in the barrel of the gun and a burst of gas or slag follow.

It is safer to feed the clay into the gun with a shovel rather than to stand close to the hole and trough, unless one is expert at throwing the balled clay into the funnel from a safe distance. (See Figs. 17 and 18.) As stated before, use a stick—not your foot—to poke clay down into the funnel. While stopping the hole do not stand so that all your weight is on the sheets covering the trough, and watch for the exhaust steam. Do not put the wind on until the hole has stopped taking clay freely, and after

the hole is stopped leave the gun in it with steam on until the clay has set; this may prevent a breakout at the tapping hole between casts. If men are changing tuyères or plates, never throw or turn water into the funnel of the mud gun or use wet clay before the hole is entirely stopped, as gas may blow out on the tuyère men. Step away from the gun for a moment when shooting water into the hole.

In putting water in the skimmer trough at "rid-up," do not stand near by with a short nozzle to turn the water in (Fig. 19). If the water strikes hot slag, the steam may scald you, and if it strikes a pocket of hot molten iron there may be an explosion. It is safer and just as effective to use a pipe, 15 feet or more long, turned down at the end (Fig. 20). If it is necessary to break up crusts or skulls in the trough before turning water on, don't use a cold or wet bar. When handling hot scrap or slag use tongs or a hook whenever possible, and be careful in breaking or barring slag and scrap to avoid flying pieces, falls, or dropping material on to your feet. Before throwing scrap or cinder into a car, be sure there is no one in it and that the pieces do not project over the end or sides of the car where they may fall or be pushed off.

Under Blast Precautions

Never tighten the keys on the tuyère stocks or caps, or take up slack on the bridles when the blast is on unless you are directed to do so by the foreman. Watch for tight bridle springs or split stock hangers, and don't screw up the nut on the bridle until the spring is tight. Do not start to loosen the monkey or stock bridles, hangers, keys or caps until the blast is off and the gas is drafted back. Wear goggles when watching the peep sights during a cast or check, and do not open the peep-sight plug until



FIG. 16. MODERN RUNNER GATE OPERATED BY A CABLE AT A SAFE DISTANCE FROM THE RUNNER. ONLY A PART OF THE CABLE IS SHOWN.

you are sure no one is in line with it. Don't try to blow coke out of the eyesights until the blow pipes have had time

KILLED AT BLAST FURNACE

Sault Ste. Marie, Ont., Jan. 24. —While engaged at his work at the blast furnace of the Algoma Steel Corporation yesterday Emil Provost, an unmarried Frenchman, twenty-four years old, whose home is in Ottawa, met his death while tightening up a door of one of the furnaces while the pressure was on. He had resided in the Soo only about one month.

to cool. Know where the hose and water valves are situated in the cast house, as they are needed quickly at times. When playing the hose on tuyères, blowpipes, or the furnace jacket, stand behind a

column as much as possible, or to one side, as they may burst or burn through.

In case a tuyère bursts or a blowpipe burns out, do not work about them unless thoroughly familiar with the danger. Work to one side as much as possible when dropping blowpipes, claying up, and changing tuyères, as cinder, coke or gas may blow out. The tuyère opening should always be firmly plugged with clay as soon as the blowpipe is dropped. Never work about an open tuyère or plate when water or wet clay is being put in the tapping hole. Watch for hot bars, blowpipes, and scalding water or steam. Do not put up the blowpipes after a shut down until the foreman orders you to, for unless the blowing engine is turning over it might cause an explosion. Don't look into a blowpipe when cutting out clay after a stop.

When "botting up the monkey," or plugging the cinder notch, wear goggles or a mask and long leather gloves; be sure of your footing, and always use the shields provided. Work from the side of the cinder notch as much as possible when opening it, and, when breaking cinder in the runner during a flush, keep out of line with the cinder notch and be careful the cinder does not splash on your feet. Cinder will splash farther than iron. Keep as far away as possible when throwing coal in the cinder runners. It is just as well not to throw coal into stiff cinder, as it does not greatly help matters.

Do not throw damp or wet rubbish in the cinder ladles, and always examine them for water or damoness and dry them out with cinder before flashing or casting, because a damp ladle may boil or explode when being filled. Keep away from the granulating pit when the skimmer trough is being drained or when you think iron is coming over the cinder dam. If it is necessary to plug a cinder ladle with clay, always place a sign, or station a watcher before going into the ladle. Be sure there is no one in a car or ladle before throwing rubbish into it.

Reporting Abnormal Conditions

Be prompt to report anything abnormal or unusual about the furnace—for instance, the blast pressure becoming

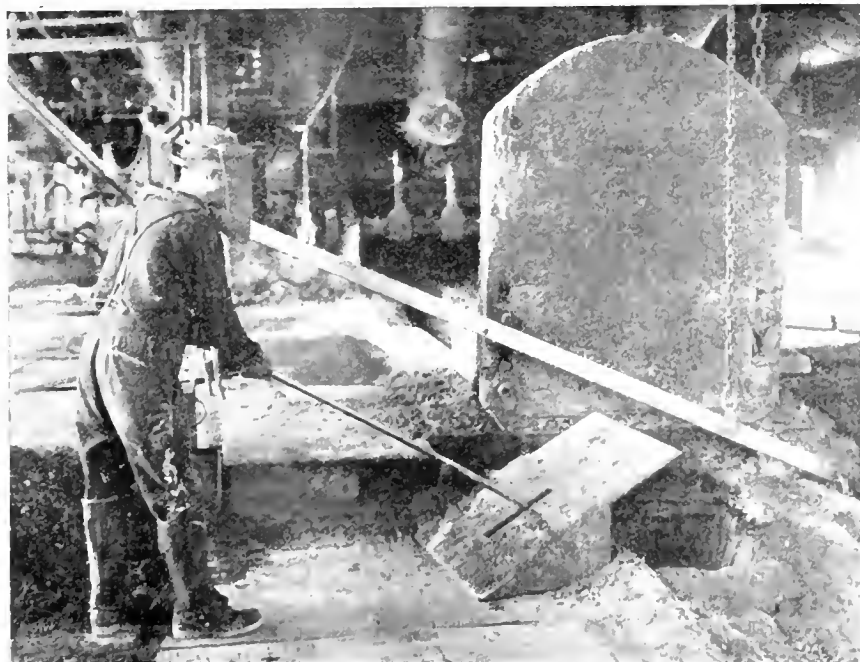

FIG. 15. SAFE METHOD OF OPERATING PUNCH-OUT GATE. Note the mask worn to protect man from splashes.

high or low; hanging, tightness, or slipping of the burden, cold or dirty cinder; sloppy, dead, or leaking tuyère; gas lighting on the bosh or about the mantle; hot spots on the shell; delays in filling the

always use burning waste; don't let the stove fill with gas and then try to light it. If the stove does not light, shut the gas off and start over again, using burning waste.

peatedly from any cause shut the mixer valve on the by-pass at once, then close the cold-blast and hot-blast valves as soon as possible. Never forget to close the mixer valve before checking or shutting down the furnace, beginning a cast, or stopping the blowing engine. To forget to do this may cause an explosion that will wreck the mains and engines. When it is necessary to take the stoves off during a shut-down to "change bronze," or for a short stop, be sure the burners are closed tightly. When ready to start the furnace and bring the gas down, never turn the gas into the stove until the blower has given the signal. Be sure that the explosion doors or bleeders on the gas mains or dust catcher are closed during a shut-down; if any air gets into the mains there is always a chance of an explosion. Whatever way the blower tells you to handle the top bleeder, whether to keep it open or shut during a shutdown, always follow his order to the word. Many serious furnace accidents are caused by operating bleeders and gas valves other than in the way ordered. The least change from orders may cause a terrific explosion. If the gas is "wild" in drafting it back in one stove at a shutdown, draft back through an additional stove at once.

Keep away from the dust legs and manhole covers on gas mains, from gas burners and air inlet doors, when the furnace is sticking and liable to slip. Be careful when you open an air door to see how the gas is burning; if too much gas is turned on, or if the checkerwork is dirty, the gas may flash back into your face. Keep and warn others away from these places; no one should handle burners, doors, or valves unless directed by the stove tender. Do not tighten any

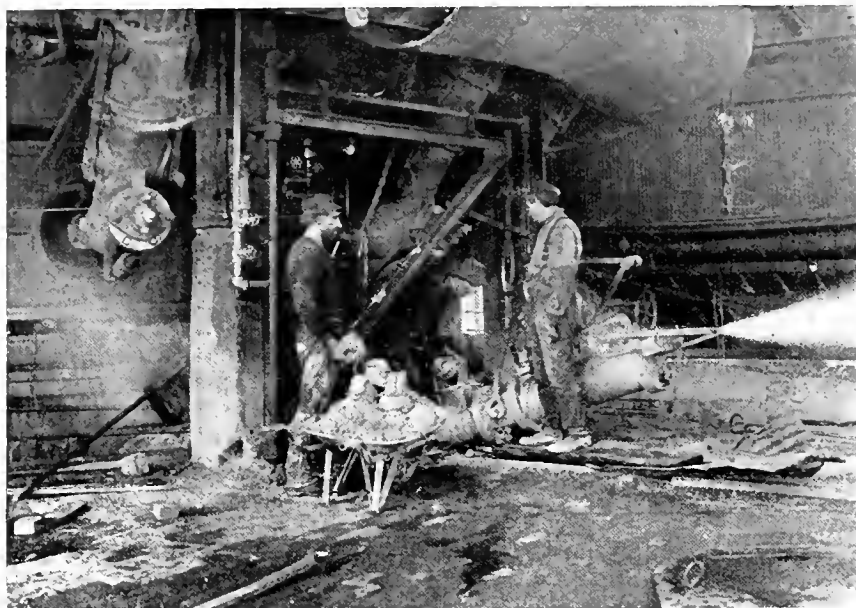

FIG. 17. UNSAFE WAY TO STOP TAPPING HOLE. Helper is using his hands and standing too near tapping hole.

furnace or in spotting iron or cinder ladles; wind and gas leaks; or signs of a break out, such as steam or gas coming from about the jacket, columns, or pavement, the water getting hot or steamy in the discharge from the hearth or bosh jacket or on the jackets, or the pavement or columns getting unusually hot. Especially, report promptly any signs of the cooling water supply becoming slack. Neglect of these points oftentimes leads to unnecessary hard work and danger from "messes," breakouts, slips, burned tuyères and blowpipes, or explosions. The foremen are looking for these signs also, but one man may not see all of them.

The Hot-blast Men

Be careful that the gas or blast is not turned into or gas drafted back through a stove that is being cleaned. Do not open or close any doors or valves or remove any signs or locks on such stoves until the foreman has told you to do so. Before turning gas into a stove, warn any well-bottom cleaners working about the doors, as it may flash back when it ignites; and be sure that the chimney valve is open. If you think that the stove is not hot enough to light the gas, put a large bunch of burning waste at the gas door or provide other means to ignite the gas. Don't stand by the burner after turning gas into the stove; step away quickly. At times the gas will not light until it reaches the top of the well or combustion chamber, and it is then likely to light explosively and puff out through the burner and air doors. Be especially careful when you are turning on gas from a furnace just blown in or from one shut down on account of leaky "bronze" (tuyères, coolers, bosh plates, cinder monkey, etc.). In case of doubt

Before you blow off a stove, warn men to keep away from the blow-off valve, and especially warn them away from the blow-off door if the stove is being shut down for a leaky tuyère, as the gas may be very explosive. Be sure that the blast is on the new stove before shutting the cold-blast valve of the stove being taken off. Don't let the hot-blast valve drop sharply on to its seat, and don't



FIG. 18. SAFE WAY TO STOP TAPPING HOLE. Helper is using shovel and standing away from the trough and the tapping hole.

let the blast slam the chimney valve into place; set the valves easily by hand. Open the cold-blast valve slowly to avoid racing the blowing engines.

In case of the blast stopping unex-

pectedly from any cause shut the mixer valve on the by-pass at once, then close the cold-blast and hot-blast valves as soon as possible. Never forget to close the mixer valve before checking or shutting down the furnace, beginning a cast, or stopping the blowing engine. To forget to do this may cause an explosion that will wreck the mains and engines. When it is necessary to take the stoves off during a shut-down to "change bronze," or for a short stop, be sure the burners are closed tightly. When ready to start the furnace and bring the gas down, never turn the gas into the stove until the blower has given the signal. Be sure that the explosion doors or bleeders on the gas mains or dust catcher are closed during a shut-down; if any air gets into the mains there is always a chance of an explosion. Whatever way the blower tells you to handle the top bleeder, whether to keep it open or shut during a shutdown, always follow his order to the word. Many serious furnace accidents are caused by operating bleeders and gas valves other than in the way ordered. The least change from orders may cause a terrific explosion. If the gas is "wild" in drafting it back in one stove at a shutdown, draft back through an additional stove at once.

thumb or other nuts on doors or blow-off valves when the stove is on blast; you may be killed or injured by the bolt breaking. Watch the water on the hot-blast valve and seat, because water leak-

ing into the stove may cause the furnace to slip or get cold; it will then be more dangerous. Report any gas leaks about the burners or mains; do not let them leak unnecessarily. When the millwright is examining the chimney valve for leaks do not change the stove from blast to gas. When the hot-blast valve and seat are being inspected be sure the chimney valve is kept open and the gas turned off.

The Stove Cleaners

Before entering a stove to clean it, lock the cold-blast valve and gas burner shut, fasten the chimney valve open, and either block the hot-blast valve in its seat or disconnect the cable from the stem, or lock the windlass, and attach danger tags; be sure these things are done. Stop any leaks about the burner with clay, as even a small leak may allow considerable gas to drift into the stove. It is always safest to close the burner door, but if this can not be done for any reason, turn the burner on its seat, away from the door or seal it off with a blank. When ladders must be used to get into a stove through the dome manhole do not try to carry tools up or down the ladder, use a hand line. (See January 25 issue, Figs. 8 to 10.) Keep away from the well of the combustion chamber, and do not sit on the bridge wall between the well and the checkerwork; the wall may give way. Boatswain's chairs for cleaning, tearing out, or repairing the well lining should be supported by tackle attached to the top of the stove shell when possible, and the chair, rope and tackle tested to double a man's weight before use. Anyone working in a boatswain's chair should wear a life belt attached to the chair-sling block. Do not use a torch inside a stove; use an electric light on a standard insulated extension cord and have an electrician make all connections.

When it is necessary to clean checkerwork from the bottom or to clean out under the arches, keep under the arches as much as possible to avoid bruises from falling brickbats, clinkers, or tools. It is best never to enter the bottom until everyone is out of the top. Always wear goggles when inside a stove and do not remove the locks from the valves until everyone is out and the manholes are closed. In cleaning the dust from the bottom of a stove be careful to avoid burns; the dust is usually hot and easily runs into one's shoes. Notify the stove tender before opening the cleaning, air-inlet or blow-off door to clean the well from the outside, and have him turn the gas off enough to avoid any danger of flame puffing back through the door at which you are going to work. In case the furnace is hanging, stop work until it slips, and keep away from the cleaning door. In loading barrows with hot cinder or dust do not fill them so full that they will run over; handle them carefully, and warn others to keep out of the way. Bars and cutters used in cleaning wells should be handled with crossbars when withdrawing them from the stove. Keep away from the doors when gas is being turned in the stove.

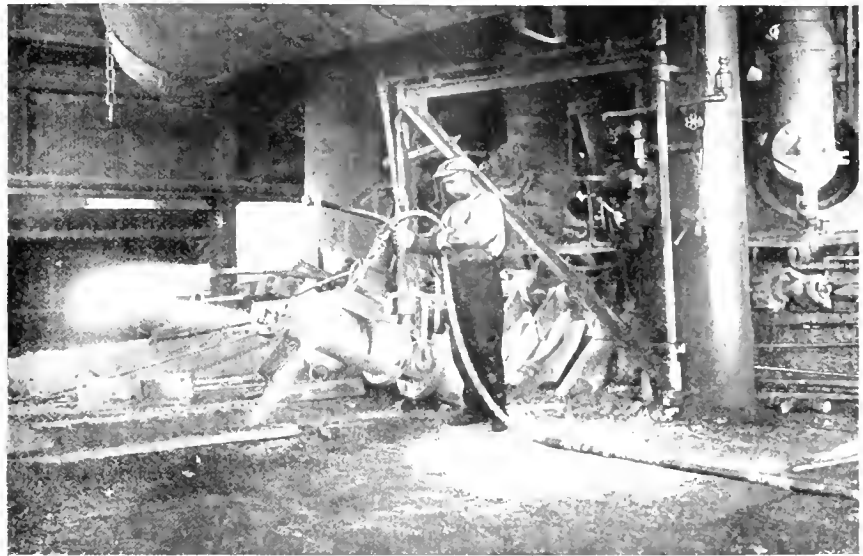

FIG. 19. UNSAFE WAY OF WETTING DOWN TROUGH AT "RIDUP"
Short nozzle on the hose, man standing close to trough where he is exposed to an explosion of hot metal or steam.

The Dust-catcher men

Empty the dust catcher regularly; if you let it get filled and the furnace slips, there may be an accident. Notify the foreman when the car is full and if the car is not moved promptly and an empty one spotted. Never dump the dust catcher when the wind is off the furnace or when the furnace is hanging or liable to slip unless you are doing it under the orders and directions of the foreman or superintendent. In dumping dust legs, dust pockets, or dust catchers be sure there is no one underneath to get burned, and warn men against approaching, as the dust may fly and burn them. Be careful in cleaning up dust and never step on it, because it will run like water when hot, and burn you severely if it gets in your shoes. Be cautious in playing a hose on hot dust, as it sometimes explodes or flies. Do not clean up under the dust catcher unless you have notified the foreman and he has told you to go ahead; the bell may be forced open by a slip or by being overweighted and the dust may

burn you. For the same reason never go into a dust car after it is spotted under the dust catcher; pack the doors before the car is placed. Turn the water on full before you open the bell, and water the dust thoroughly when dumping the dust catcher. Don't fill the car with hot dry dust and then turn the water on; it will soak down slowly, and the contents may explode. Always place a card on the car so that the unloaders will know they are handling the dust.



In a recent issue of *The Electrician* some new facts which illustrate the great impetus given to the construction of electric steel furnaces are reported. Since the outbreak of war over 100 installations are known to have been put in, and the total number in the world now approaches 300, which is about twice the number existing in 1913. The United States is credited with constructing 50 last year and Great Britain with 30 since the war began.



FIG. 20. SAFE WAY OF WETTING DOWN HOT TROUGH. EXTENSION NOZZLE ON HOSE. MAN STANDING AWAY FROM TROUGH.

EDITORIAL CORRESPONDENCE

Embracing the Further Discussion of Previously Published Articles, Inquiries for General Information, Observations and Suggestions—Your Co-operation is Invited

MACHINISTS' INSTRUCTION COURSE—XIII.

By J. Davies.

THE introduction of modern screw-cutting lathes with special appliances and attachments, has eliminated much of the calculation that used to be necessary for such work. Every capable lathe hand, however, ought to be able to make any necessary calculations relative to such work. The system of calculation as arranged by the writer is designed to carry the student forward in easy stages, and no previous knowledge of mathematics is required except an elementary knowledge of arithmetic.

Pitch of Thread

The pitch of the thread is the distance from the centre of one thread to the centre of the next, except in the case of a double or triple thread, Fig. 51; in

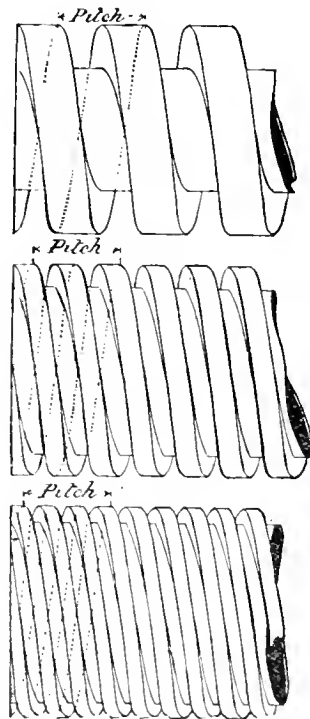

FIG. 51.

any case the pitch is represented by the distance the screw moves endways in one complete revolution.

(1) Put down the pitch of the thread to be cut in the form of a fraction. An easy way to express the pitch of any given thread is to draw a horizontal line thus ——— placing the number of threads below the line and the number of inches above the line, the resulting fraction will always be the pitch of the thread.

Example: Pitch of 6 threads per inch

$\frac{\text{Inches}}{\text{Threads}} = 1-6$ pitch, and so on for all even pitches. In cases where there is a fractional number, multiply both inches and threads by the least number that will bring them to a whole number.

Example: Find pitch of $6\frac{1}{4}$ threads per in. Proceeding as before ———

Multiplying by the least number that will bring them to a whole number = $\frac{1}{6\frac{1}{4}} \times 4 = \frac{4}{25}$ in. pitch. A little

more difficult one.—find pitch of $3\frac{2}{3}$ threads in $13\frac{3}{4}$ in. = $\frac{\text{inches } 13\frac{3}{4}}{\text{threads } 3 \ 2-3} \times$

$\frac{21}{44}$ in. pitch.

If the pitch is given in decimals bring it to a fraction by placing noughts or cyphers under each decimal figure and 1 under the decimal point, thus: pitch

of decimal .75 in = $\frac{75}{100}$ or $\frac{3}{4}$ in. and so on—pitch of decimal .125 in. = $\frac{125}{1000} = \frac{1}{8}$ in. and so on. Having found

pitch of screw to be cut, find pitch of leading screw in the same way.

A Matter of Ratio.

The whole principle of gearing up a lathe for screw cutting is one of ratio or proportion. The ratio of the driving to the driven wheels must be the same as the pitch of the screw to be cut is to the pitch of the lead screw. Suppose the thread to be cut was the same pitch as the lead screw, then it is evident that the work must make the same number of revolutions in the same time as the lead screw.

Example: Pitch of screw to be cut is $\frac{1}{4}$ in.; pitch of leading screw $\frac{1}{4}$ in.—find ratio. Rule: Invert or turn upside down pitch of leading screw in inches, and multiply, the reason for turning the fraction upside down is because the wheel with the least number of teeth

makes the most revolutions. $\frac{\text{Inches } 1}{\text{Thread } 4}$

invert pitch of leading screw and multiply = $\frac{1}{4} \times \frac{4}{1} = \frac{4}{4}$ ratio. After find-

ing ratio, a number of different sets of gears can be found by multiplying the ratio by any number we choose, but care must be taken to multiply both numerator and denominator by the same figure so as not to alter its value.

Find wheels to cut 4 threads per in. leading screw 2 threads: thread to be cut = $\frac{\text{inches } 1}{\text{threads } 4}$. Leading screw

= $\frac{1}{2}$ in. pitch: invert leading screw and

multiply $\frac{1}{4} \times \frac{2}{1} = \frac{20}{40}$.

Find wheels to cut 31-7 threads in 2 1-5 inches with a lead screw $\frac{1}{2}$ in. pitch?

$\frac{\text{Inches } 2 \ 1-5}{\text{Threads } 3 \ 1-7} \times 35 = \frac{77}{110}$. Invert

lead screw pitch and multiply = $\frac{77}{110} \times$

$\frac{2}{1} = \frac{154}{110}$, or $\frac{77}{55}$ wheels required, or

bringing the fraction down to its lowest dimension we have $\frac{154}{110} \div 22 = \frac{7}{5}$ or $\frac{70}{50}$

from which any number of different sets of wheels may be obtained.

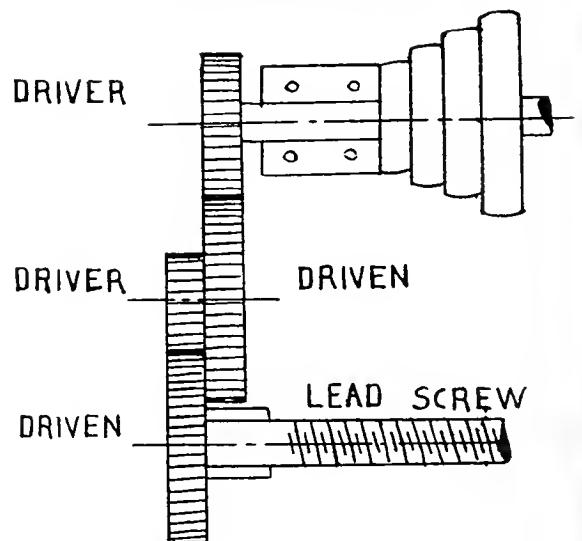

FIG. 52.

Compound Gearing

Sometimes it happens that the number

of teeth in a gear wheel would be too large to employ a single train of wheels; in this case compound gears must be used. Here is an example that would require compound gears. To cut 24 threads per inch with a lead screw, two threads per inch. Proceed to find ratio

$$\text{as before: } \frac{1}{24} \times \frac{2}{1} = \frac{2}{24} \text{ ratio. Take}$$

the numerator of the ratio, which is two, and find any two numbers which, multiplied together, will equal that number. Then take the denominator of the ratio, which is 24, and find any two numbers

$$\text{which, multiplied together, equal } \frac{2}{24} =$$

$$\frac{2 \times 1}{12 \times 2}$$

We have now divided the ratio into four factors of equal value, which will enable us to use compound wheels. We can take any figure in the numerator or denominator and multiply, add, or subtract at will, as long as we do not alter the relative values in adding or subtracting; the amounts added or subtracted must be the same proportionate amounts of each, such as 1-3 or 1-4 or 1-5, and so on as the ease may be. Take the first two figures in our example and

$$\text{multiply each of them by ten } = \frac{2}{12} \times 10$$

$$= \frac{20}{120}$$

$$\text{and multiply by } 50 = \frac{1}{2} \times 50 = \frac{50}{100}$$

Wheels required, therefore, are
20x50 Driving wheels.

120x100 Driven wheels.

The two top wheels are driving wheels and the two bottom wheels are driven. The sketch, Fig. 52, illustrates the position of the wheels on the lathe.

It is required to find gears to cut 16 threads per inch—lead screw $\frac{1}{2}$ in. pitch?

$$\frac{1}{16} \times \frac{2}{1} = \frac{2}{16} = \frac{2 \times 1}{4 \times 4} = \frac{20 \times 30}{40 \times 120}$$

Proving the Wheels

To prove the wheels, multiply all driven wheels together; then multiply all the driving wheels together and divide the driven by the drivers. If the wheels are correct, you will get the same ratio or proportion as exists between the pitch of the leading screw and the pitch of the screw to be cut. Take the above example—driven wheels, $40 \times 120 = 4800$; driving wheels $= 20 \times 30 = 600$. $4800 \div 600 = 8$. Ratio of wheels between driver and driven $= 8$ to 1.

Threads to be cut 16 8 ratio required.
Threads on lead screw 2 1

MACHINING 4.5 SHELL CARTRIDGE CASES

By J. Hamilton

THE delicate nature of the brass cases that contain the propellant for the

smaller size shells offers every means of displaying originality in the development of appliances for their rapid and economic handling while machining. Following the tapering operation on the 4.5 in. cases, it is necessary to remove some of the metal from the interior of the mouth, and retain at the same time

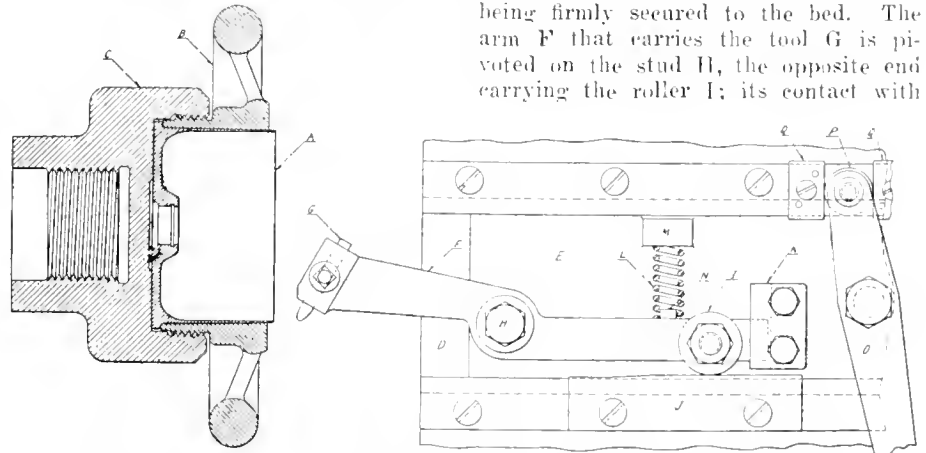

DEVICE USED IN MACHINING MOUTH OF 4.5 IN. CARTRIDGE CASES.

a uniform thickness of metal at all points on the circumference. How one plant performs this operation is described and illustrated by the accompanying sketch.

The cartridge case A is placed in the special hand-wheel B, the bore of which is machined to an accurate fit for the external taper of the case. The boss of this wheel is threaded to fit the chuck

speed lathe. By this method the head of the case is forced against the inner face of the chuck, with the outer end running true. With the machine operating, C, which is screwed to the spindle of the lathe at high speed, the cutting is rapidly performed. A special block E was made to operate in the slide D, this being firmly secured to the bed. The arm F that carries the tool G is pivoted on the stud H, the opposite end carrying the roller I; its contact with

the cam J governing the shape of the case bore. The plate K acts as a support for the extended tail of the tooling arm F. Contact between the roller and the cam is maintained by the action of the spring L. The forward movement of the tool is derived by means of the lever O, the short arm carrying the roller P, operating between the two blocks Q, secured to the gib of the slide.



ELEVATING PLATFORM

By E. T. S.

ALMOST every manufacturing plant has a lifting proposition somewhere or other, in which the lifting platform style would be the ideal thing. The method outlined in the following may be very simply arranged in plants where compressed air is employed, for the reason that practically the whole outfit is made from standard pipe fittings. The elevating platform, shown in diagram, shows the simplest form of this arrangement with a single piston. We have in use at our plant several of these elevators which have a second piston, that is to say, the telescopic pipes comprise three pipes instead of two as shown. The base of the outer pipe is simply a pipe flange which is bolted to the base plate covering bottom of pit; a hole in the centre provides the air inlet. The top end of this outer pipe is threaded on to a reducer coupling bored out to suit size of inside pipe. The bottom end of the inside pipe is fitted as a piston with a single leather packing ring, and at the top end is a standard flange to which is attached the elevating platform. If the platform is large, it is necessary to provide guides in order to steady ascent and descent. For these guides we have four pipes $3\frac{1}{2}$ inches diameter, into which slide four pipes 3 inches diameter. The larger pipes are fitted with standard flanges, and bolted to bottom

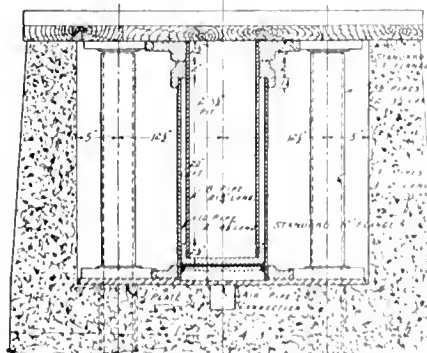
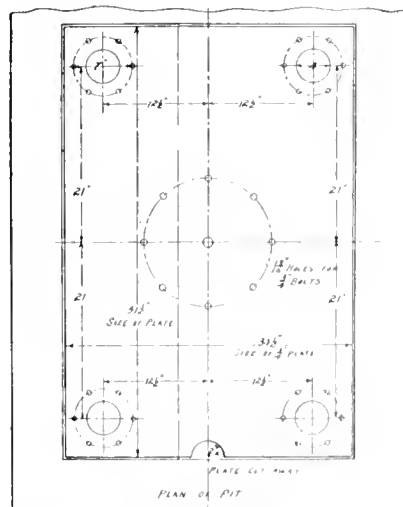

ELEVATING PLATFORM DETAIL.

plate, while the smaller pipes are similarly fitted and bolted to underside of platform. The whole is built up in a concrete pit having the platform ground level, so that trucks can be run on easily, and is controlled by a standard 3/4 inches four-way valve. It is a low-priced elevator, gives good service, and hard to put out of service.

TWO USEFUL KINKS

By John Thorn.

TAKE an ordinary monkey wrench, drill two holes in the jaws for 1/4 in. steel pins, cut a slot in the upper jaw to admit an ordinary cutter wheel, and another slot 3/8 inches wide in the olwer jaw for a roller; a cutter wheel can be used instead of the roller if desired. This converts the

wrench into a passable iron pipe enter, Fig. 1. By removing the pins and cutters, the wrench can be used as usual.

Another useful idea is shown in Fig. 2, this being a pump for testing pressure gauges. The body is a piece of 1 1/2 in. heavy brass pipe, threaded at each end with standard pipe threads; a light cap is put on one end, while on the other end is threaded a heavy cast iron cap drilled in the centre and tapped for an ordinary 7/8 in. bolt. A long stem, with a T-handle, is threaded nearly the whole length as shown. This stem is a piece of 3/8 in. iron or brass rod which, with two iron washers, nuts and a cup leather, forms a plunger. A test gauge and a gauge to be tested are attached to the elbows at A and B.

Before testing or attaching the gauges, place the lower elbow in a dish of water and leave the pit cock at B open and the one at A closed. Screw the plunger down as far as it will go, and then turn it back to the upper position with the elbow under the surface of the water; this will fill the pumps with water. Attach the gauges, open the pet cock and turn up on the T-handle, when

surface of brass tube is usually much smoother than iron.

When a gauge is either weak or strong, all that is usually necessary to put it right is to remove the pointer and dial, oil the inner mechanism with a little coal oil, using a tooth brush (be sure none of the bristles are left behind), and replacing the dial and pointer so that it will just rest against the pin. Of course, if any cog or sector teeth are broken, or the spring tube is leaking, that is another story; but nine times out of ten all that is wrong is the pointer. The writer remembers once finding fine pressure gauges in a plant, all of which had been discarded as useless, and in less than an hour had tested all of them, moved the pointers, and after testing again, they were absolutely correct with the test gauge. Gauges should not be placed where they will become hot, and steam should never be allowed to enter the spring, either of which conditions will ultimately destroy its usefulness.

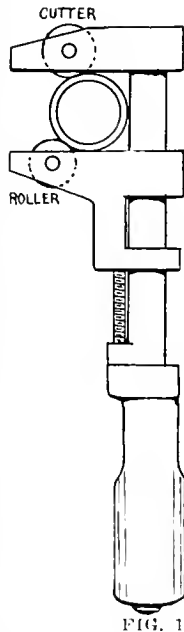

FIG. 1.

FEDERAL GOVERNMENT EXPENDITURES

THE main estimates for the coming fiscal year, tabled in the House of Commons, Ottawa, by the Finance Minister, provide for a total expenditure of \$203,472,756, of which \$182,359,215 is on Consolidated Fund account, or for the ordinary expenses of administration. The total amount for capital expenditure is \$21,113,546.

There is a very considerable scaling down of expenditures for public works and for railways and canals on both Consolidated Fund and Capital Account. The biggest increase is the interest on the public debt, which jumps from \$37,000,000 to \$54,000,000. The war is also responsible for an increase in the pensions bill by \$5,398,000. The amount required for the coming year is \$8,763,000. There are scarcely any new public works authorized. There is a reduction of \$11,026,162 in the total expenditure to be voted for public works under Consolidated Fund Account, and of \$2,482,000 for public works on Capital Account. The reduction on railways and canals expenditure on Capital Account is \$12,216,756.

As compared with the estimates of last year there is a reduction of \$1,500,000 in the total for Consolidated Fund Account, and of \$16,000,000 in expenditure on Capital Account. The estimates, of course, do not include anything for war appropriation.

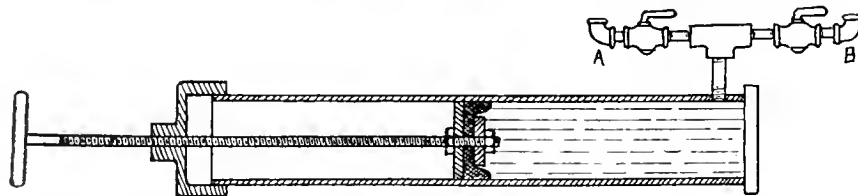

FIG. 2.

a pressure of several hundred pounds can be secured with ease. The reason for using brass tube is because the inner

Some of the Chief Items

The main items on Capital Account for railways are \$6,500,000 for con-

struction and improvements of Government railways, \$200,000 for Welland Ship Canal construction (as compared with \$4,500,000 last year), \$600,000 for canal inspection, \$1,600,000 for the Quebec Bridge, and \$3,000,000 for the Hudson Bay Railway. The main items on capital account for public works are \$2,000,000 for the restoration of the Parliament Buildings, \$1,000,000 for St. John harbor improvements, \$1,000,000 for the drydock at Quebec, \$1,000,000 for Toronto harbor improvements, \$750,000 for Port Arthur and Fort William harbor improvements, and \$1,000,000 for Victoria, B.C., harbor improvements.

The vote for Federal aid for agricultural instruction in the provinces under the Act of 1912 is increased to \$1,100,000, or by \$100,000. The Immigration Department vote stands at \$1,215,000, a decrease of \$359,000 as compared with last session.

I. C. R. War Business Increase

The recent big increase in traffic on the Intercolonial consequent largely upon war business is mainly responsible for increasing the last year's vote for Government railway working expenses from \$13,850,000 to \$25,000,000 for the coming year. Supplementary estimates are, of course, still to come. If an election impends, a long list of further votes for public buildings and for rivers and harbors may be expected.

Silvering Brass for Lacquering.—It often happens, in finishing ornamental work, that silver bands or reliefs are needed, the thickness of the silver, of course, being a minimum. To make a good and efficient solution for the purpose, dissolve 1 oz. of good nitrate of silver in a quart of distilled water, and in a separate vessel make a semi-saturated solution of hyposulphite of soda. Add sufficient of the hyposulphite solution to the nitrate of silver solution to throw down the silver as a brownish precipitate, agitating the liquid; then add, drop by drop, sufficient of the hyposulphite to re-dissolve the precipitate, and after this is secured add a slight excess of hyposulphite. Store in black or other non-actinic glass bottles, well corked. To use, apply to the clean metal with a sponge or brush, and rinse off with clean water, and dry thoroughly before lacquering.

THE resistance of a material to fatigue depends entirely on the homogeneity of its physical equilibrium, and is proportional to the toughness and the elastic limit. Any outward conditions that tend to alter the state of the homogeneity more or less have a weakening effect on the material, and in extreme cases cause ultimate failure. When a metal is subjected to repeated alterations of stress a series of slips take place along the gliding planes of the crystals. The slipping action, which is characterised as fatigue, continues backwards and forwards until actual rupture takes place.

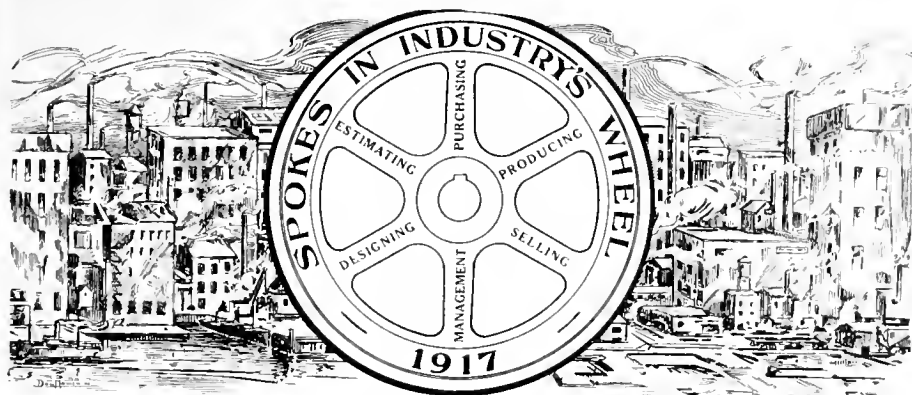

The constitution of industrial enterprise is largely departmental—"spokes in a wheel." This series of articles has for its object the featuring in a racy, interesting and instructive fashion, the training, experience and achievement of those who to-day are transmitting, effectively, energy in their capacity as "spokes in the wheels" of our metal-working establishments.

WILLIAM J. McCALLUM

SOME men are born to fame, while others have fame thrust upon them. Neither of these conditions apply to our "Spoke" this week, however, as the reputation which he enjoys in his official capacity of chief fengineer and superintendent of the Chapman Double Ball Bearing Co., Toronto, has been worked for, and duly earned from the day when, as a school boy, he decided that his summer holidays could be better employed picking up the rudiments of a machinist's trade, than by whiling away the sunny hours in care-free indolence. That this industrious trait, which thus early showed itself, was not of transient nature, can be vouched for by many friends of our "Spoke."

William J. McCallum, sometimes Billy, and always Mac, is a Canadian by birth and parentage, although when occasion demands it, he exhibits a justifiable pride in the fact that one of his ancestors came from the land of "hoots," heather, and highland dew. This was 'way back in 1832., however, so that, with the exception of his name and a characteristic persistency in applying himself to the question of the moment, Mac, being a lifelong teetotaler, has very little left to indicate that his forebears wore the kilt.

Mac first saw the light of day at Woodbridge, York County, Ont., on Nov. 17, 1879, and towards the termination of his public school days, spent some weeks each summer with the Toronto Electric Works, Toronto. School days came to an end, however, and the serious work of life began with the Diamond Machine Tool Co., the time spent there being also occupied with studies at the Technical School, followed later by a Correspondence Course in mechanical engineering. Subsequent experience with the John Abell Co. was followed by two years in charge of the fitting and lathe department of the Dodge Mfg. Co., at the early age of 24 years. The experience gained here in transmission machinery and equipment was of particular value in view of ultimate developments.

After a subsequent stay with the

American Abell Co., Mr. McCallum, in 1907, secured the position of chief draftsman with the Chapman Double Ball Bearing Co., with whom he has remained ever since. His experience, therefore, has been secured entirely with Toronto firms, a fact which is mutually creditable.

Mr. McCallum's work in connection with the ball bearing industry in Canada constitutes a record of consistency.



WILLIAM J. McCALLUM.

persistency and efficiency, of which few other lines of effort offer any comparable instances. Taking up this work at a time when antifriction bearings and similar power saving devices were under a cloud of disfavor due to unwise exploitation, the pioneer period of his work was truly uphill. Experience in all new lines of manufacture is always fraught with more or less trouble, and in just so quickly and efficiently as this experience is obtained and turned to good account, so the progress of any new business is determined. It is interesting to know, therefore, that the rapid and continual growth of ball bearings as regular items of factory equipment dates from the time of Mr. Mc-

Callum's connection with the business; all of the types of Chapman bearings now on the market having been re-designed by him in accordance with results obtained in every branch of Canadian industry. Pulp mills, steel mills, cotton mills, lumber mills, machine shops, quarries, brick works, clothing factories and arsenals are but a few of the numerous fields into which our subject has ventured in support of his present efforts.

The large field for observation thus obtained resulted in a due appreciation of possibilities in other efficiency equipment besides ball-bearings. The Universal elevating truck now being marketed by his employers is the direct result, in considerable measure, of Mac's inventive ability, which has had full play since munitions manufacture became a quasi-staple industry of this country; a popular type of banding press and considerable accessory equipment for shell manufacture are personal products.

Close application to work has somewhat restricted our friend's opportunity for travel, although he admits a desire to plant his foot on his native heath and conjure up scenes of McCallum More and Roderick Dhu in the midst of their native hills. The larger industrial centres of the States, however, have been frequently favored with his presence of recent years, while several remote parts of Quebec Province and Northern Ontario have been visited in the course of missionary work—for ball bearings, of course—which leads one to remark that Billy adheres to the faith of his fathers and is a staunch Presbyterian.

His views on the subject of religion are shared by his wife, who became Mrs. W. J. McCallum sixteen years ago. Their family consists of three daughters and one son, and their residence in Toronto is at 62 Mountview Ave.

Home life claims the most of Mr. McCallum's affections to the detriment of politics and allied activities. He is quite free of any political bias; an intense admiration for and loyalty to the British Empire being the most prominent streak in this direction. The same absence of sectarian views is evidenced in his attitude toward affiliations and societies; the "Brotherhood of Man" typifies his outlook on humanity, although in some quarters the view is rather gloomy.

His outlook on the question of engineering is not gloomy, however, and the joy of future competition will be welcomed as bringing further fields to conquer. In this respect Mac is very frank in expressing his indebtedness to technical journalism of all kinds. "Starting life on the level with the rest of us, uninfluenced and unaided, no man, who is willing to work and take advantage of present day educational facilities need be lacking in that education which contributes so much to success. A thorough technical training imparts a lasting demand for technical knowledge of current developments, and in this direction lies what I consider one of the outstanding features of successful trade journalism."

MACHINING FLY-WHEEL ON AUTO-MATIC TURNING MACHINE

Herbert's Monthly.

IT may be generally stated that all turret lathe chucking work is suitable for production by automatic turning machine methods, provided it is within the

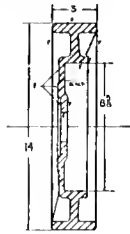

FIG. 1.

capacity of the machine as regards length and diameter, and that the articles required are in sufficiently large quantities to warrant them being made automatically. The fly-wheel shown in Fig. 1 is, therefore, an ideal piece of work, and will afford a good instance of an efficient lay-out of automatic turning machine tools. The fly-wheel is an iron casting.

At the first operation, shown in Fig. 2, the casting is gripped under the rim by special jaws in an 18-in. special chuck, the large bore being inwards, and the casting is set back against the jaws themselves; in the chuck is a standard steady bush and liner. In the line drawing, Fig. 2, the various tools have been numbered to facilitate reference to the operations.

1.—This is a standard facing tool, carried in the back tool post, and rough faces the edge of the rim.

2.—This is a standard slide facing tool, carrying three cutters for facing the portions which are inaccessible from the cross slide. The direction of traverse is shown by the arrow, and the slide facing tool is operated by the pusher, which is clamped in one of the tool slots of the back tool post. It will be noted that four tools are, therefore, cutting simultaneously, making the facing a very rapid operation. During the facing operations the turret is held in position by a retaining cam.

3.—This is a standard combination tool, carrying a boring bar for the 2-in. hole, a second boring and facing tool

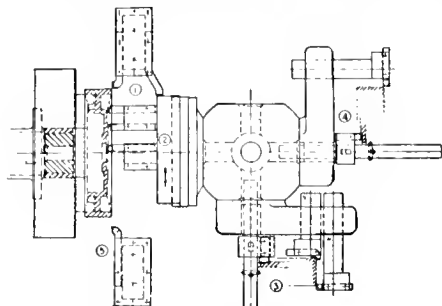

FIG. 2.

for the spigot recess, a rough turning cutter for the outside of the rim, and a radius cutter for the edge. A positive

drive to the cutter head clamped on the boring bar is obtained by another turning tool holder in one of the empty holes, but this is not shown in the drawing.

4.—This is another combination tool, which carries a finish boring bar for the 2-in. hole, a sizing cutter for the spigot, and a finish turning cutter for the outside. The finish turning cutter and a single point boring cutter are arranged so that they have ceased cutting before the sizing cutter for the spigot comes on to the work. This is done so as not to disturb the sizing cut.

5.—This is a finish facing cutter for the edge of the rim, carried in the front tool post, and operated simultaneously with 4.

At the second operation the fly-wheel is gripped by the finished outside dia-

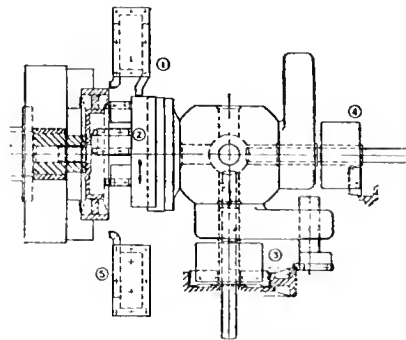

FIG. 3.

meter in soft jaws and located true by a special steady bush, which fits in the spigot recess machined at the first operation. As this recess is shallow, the steady bush is made from case-hardened mild steel, and, therefore, has to be bushed with a bronze liner, otherwise the boring bar would gall up. (See Fig. 3.)

1.—This is a standard facing tool, carried in the back tool post, and rough faces the edge of the rim.

2.—This is a standard slide facing tool, carrying four cutters for facing the portions which are inaccessible from the cross slide. The direction of the traverse is shown by the arrow, and the slide facing tool is operated by the same pusher as used in the first operation, except that it is turned round, with the offset on the other side. It should be noted that in the slide facing tools, rough and finish cutters, are provided for each part to be faced, and the roughing cutters are completely off the surface before the finishers start cutting.

3.—This is a standard combination tool, carrying a bar, on which is clamped a standard boring head for the large bore. This bar is the same one as used in the first operation. The combination tool also carries a radius cutter for the edge of the rim, and a positive drive for the boring head is obtained by another turning tool holder in one of the empty holes, but is not shown in the drawing.

4.—This is another combination tool,

which carries a finish boring head for the large hole. It is obvious that the combination tool is not necessary at this operation, and a standard boring bar holder could be used in its place. However, the combination tool is already in position on the turret after the first operation, and forms a useful means of carrying the boring bar.

5.—This is a finish facing cutter for the edge of the rim; it is carried in the front tool post, and operated simultaneously with 4.

The machining time for the two operations is 35 minutes.

CHAIN SHELLS

A RECENT British patent refers to a chain shell, illustration and description of which follows. It consists in the employment of a chain or chains wound around the gaine and separated by discs or cylinders which will keep the chains in place until the projectile case is emptied. A simple form of the invention is that in which the projectile is loaded with short lengths of chain which are laid therein in coils, but which will, after explosion, become stretched and, in addition to having a high forward speed, will rotate, and thus assist in increasing the ripping effect. These lengths of chain may have weights attached to their ends, and are preferably laid in short spirally-wound coils, separated to prevent the chain becoming entangled, and increase its velocity. Figs. 1 and 2 show sections of two forms of projectile constructed in accordance with this invention. In Fig. 1 a series of two discs D joined together by short tubes adapted to drop over the gaine and constructed to receive the chains E are used. In Fig. 2 the space C is divided by two

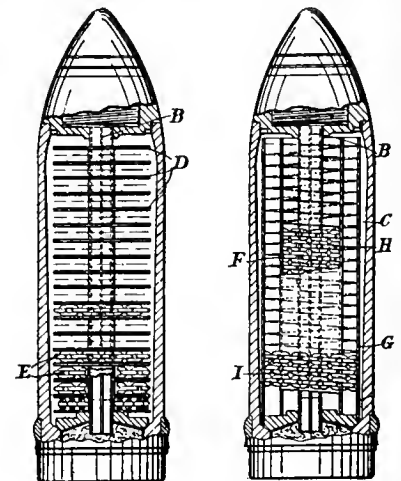

FIG. 1. FIG. 2.
CHAIN SHELLS

cylinders F and G of press-pan or other suitable material and a coil chain H is laid in spiral fashion around the gaine B and inside the cylinder F, whilst the second chain I is similarly laid around the outside of the cylinder H and inside the cylinder I.

PROGRESS IN NEW EQUIPMENT

A Record of New and Improved Machinery and Accessories for the Machine, Pattern, Boiler and Blacksmith Shops, Planing Mill, Foundry and Power Plant

COLUMN FILING MACHINE

A FILING machine embodying novel yet well-tried principles of design is illustrated herewith, being of the column type supported directly from the ground. It is built with a solid type table and all of the adjustments necessary are made in parts above the table. A three speed cone pulley belt drive

is provided on the end of the main shaft which in turn operates the vertical ram by connecting rod, the stroke being adjustable from $1\frac{1}{2}$ in. to $2\frac{1}{2}$ in. and the chuck being adjustable to take standard straight files without any additional work of babbitting etc.

An adjustable hardened roller bearing takes the side pressure of file, and is adjusted by a knurled screw so as to allow the angle of the file to alter when the head is swiveled to the desired degree indicated on the scale shown. A pedal operated clutch on the main shaft controls the starting and stopping.

All bearings are of phosphor bronze, and all working parts are above the file eliminating trouble and wear due to par-

ticles of metal getting between them. The Noble and Westbrook Mfg. Co., Hartford, Conn., are the makers of this machine.



UNIVERSAL FLUE WELDER

A UNIVERSAL flue welder is shown in the accompanying illustrations, which has been developed by the Southwark Foundry & Machine Co., Philadelphia, to meet conditions that have arisen since the general adoption of the locomotive superheater. While built sufficiently heavy to perform the welding of large flues, the machine takes safe ends of greater lengths than the limits of previous types of welders.

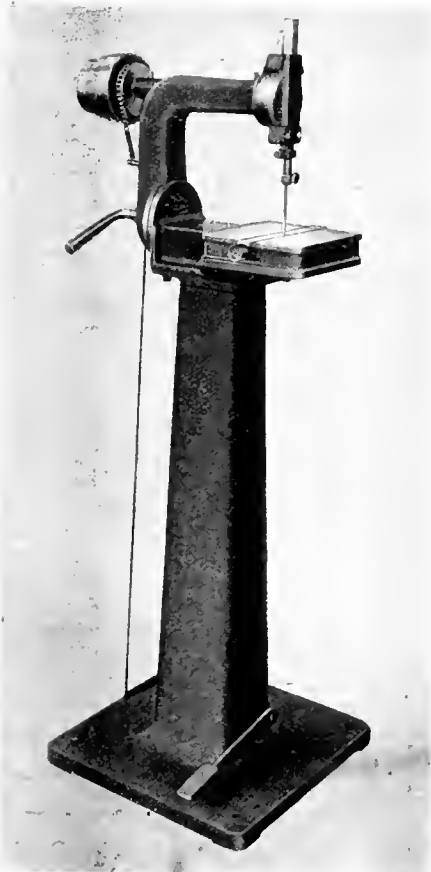

FILING MACHINE WITH OVERHUNG SWIVELING HEAD AND ADJUSTABLE FILE SUPPORT.

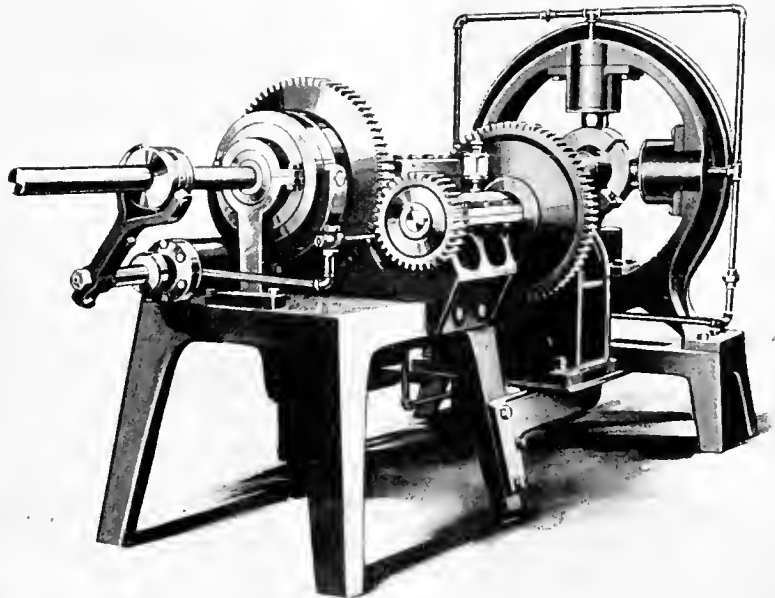

REAR VIEW OF FLUE WELDER SHOWING END OF MANDREL EXPANDING SHAFT.

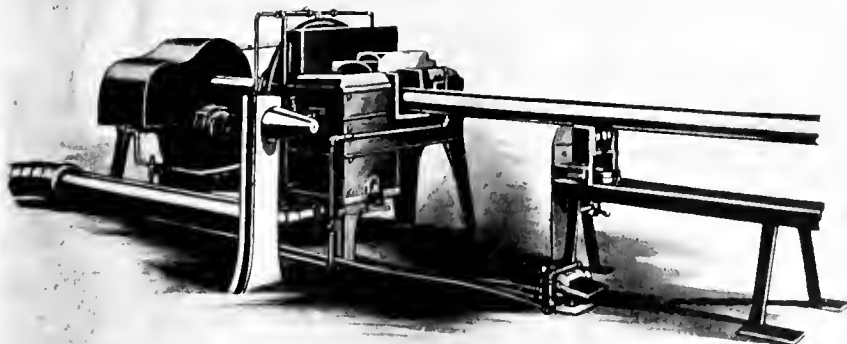

FLUE WELDER WITH GUARDS AND FURNACE ATTACHED.

A special device on the welder enables the weld to be worked on the inside instead of on the outside, thereby avoiding trouble arising from outside welding which works the metal down to a solid mandrel, the consequent reduction of area being detrimental from the viewpoint of free passage of gases, as well as preventing the entrance of superheated elements.

The machine consists of two main parts, the clamping head at the front, and the driving mechanism at the back. The clamping head is made from one circular-shape casting, four air cylinders mounted on the inside. The pistons are fitted with metal snap rings, instead of the ordinary cup leather type. The front end of the piston rods are equipped with sectional dies, which clamp the outside of the flue at the line of weld.

the cylinders operating simultaneously with the opening of the valve.

Running through the centre of this head longitudinally with the machine is the welding mandrel which fits the inside of the flue. Four rollers are assembled in the body of this mandrel, which is hollow. Tapered and free in their bearings, they can be moved radially by inserting a taper mandrel that reaches through the middle of the spindle from the back of the machine. This mandrel is operated by an air cylinder also controlled by the main foot valve. The main mandrel is driven through two gear reductions to a $1\frac{1}{2}$ h.p. motor.

A cast iron tank or water back protects the welding head from excessive heat from the furnace. The size of the mandrel, back of the welding rollers, approximates the inside diameter of the flue. This supports the weight of the safe end while being

heated and moved to the welding position, which prevents any loss due to the dropping off of safe ends, as frequently occurs.

Standing away from the furnace, the operator uses a foot valve which controls the entire operation of the welder. The piping is so arranged that the clamping heads close in on the outside diameter of the flue before the taper mandrel expands the rollers to make the weld. Driven directly from the motor, the mandrel is started by an air chuck operating automatically with the clamping of the flue.

It is customary to rig up the front of the machine with some type of roller table to support the long flue, and with this complete equipment, one crew easily can weld in a day of ten hours 120 super-heater flues.

The machine has a capacity up to 5 $\frac{1}{2}$ in. flues, uses air pressure of 80-100 lbs. per sq. in., and is driven by a $1\frac{1}{2}$ horse-power motor. The air pistons are 7 in. dia., speed of mandrel 100 revs. per min., and floor space occupied 3 ft. 6 in. x 9 ft.

AKIMOFF DYNAMIC BALANCING MACHINE

A PERFECT dynamic (running) balance is something very hard to obtain. On other hand, it is often to be desired, particularly in high speed machines. The importance of running balance in high speed machinery is well understood. Rotating machinery cannot run properly unless it is perfectly balanced. Even a small amount of unbalancing will give

rise to a host of troubles, such as, noise, vibration, excessive power consumption and undue wear of the bearings. These effects are especially serious in high speed machinery, as for instance, automobile crankshafts, motor armatures, and turbine runners.

As a means for determining the

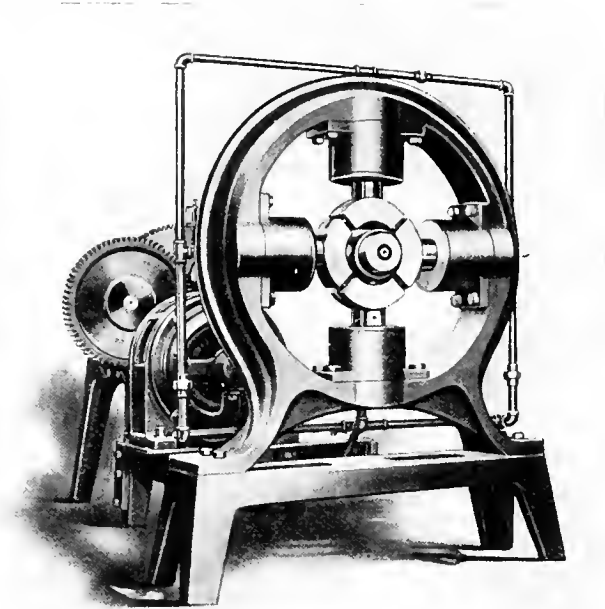

FRONT VIEW OF FLUE WELDER SHOWING CYLINDERS, DIES AND MOTOR.

amount of unbalance obtaining and correcting it, Mr. N. W. Akimoff, chief engineer of the Dynamic Balancing Machine Company of Philadelphia, Pa., has perfected this machine. The machine is driven by a Westinghouse motor and the picture shows it ready for balancing a motor armature. The balancing of rotating elements of electrical machinery and of automobile shafts have, so far, been two of the most successful applications for which this machine has been used. The principle upon which the machine operates may be described as follows:

An unbalanced condition of a body rotating at a relatively high speed may be due to lack of static balance or lack of dynamic balance. An indication of static unbalance may be obtained with a static balancing machine. Correcting for such unbalance involves drilling one hole or adding one weight to bring the centre of the mass of the body on the axis of rotation. In a statically balanced body, however, two masses on opposite sides of the axis of rotation, located axially at a distance from each other, form on rotation, a couple which develops vibrations, as is noted in defective commutators in electrical machinery, etc. The Akimoff dynamic balancing machine furnishes a means for determining easily and correctly the magnitude and plane of the couple, by the establishment of another couple,

which, maintaining the static balance, counteracts the couple which produces dynamic unbalance. The magnitude and plane of this couple indicates the correction to be applied to the body under test to produce a perfect dynamic balance.

A rigid horizontal beam, such as a lathe bed is hinged at one end of the machine and supported by a spring at the other. The body to be tested, already in perfect static balance, is rotatively supported on the beam. If dynamically unbalanced, the body will, on rotation, cause the beam to vibrate in a vertical plane. The object of the spring is to amplify the vibration. A so-called squirrel cage is located on the underside of the beam and, in operation, is rotated in unison with the body being tested. This squirrel cage consists of two circular discs carrying an even number of rods arranged slidably in the two discs and parallel to the axis of rotation of the cages. When the ends of the rods are in one plane, the cage is in both static and dynamic balances, but if two opposite rods are displaced the dynamic balance is destroyed and the couple produced will itself cause vibration of the beam. One pair of rods in the squirrel cage would suffice if the relative position of the rods could be altered through the transmission device, but for convenience, three or four pairs are employed and even then it is sometimes necessary to change the angular position of the cage so that the balancing can be done by one pair of rods and not two.

In making the test of a body the cage is adjusted so that the vibration produced in the beam by the body are damped out by those set up by the squirrel cage. An arrangement whereby the rods of the cage may be adjusted axially while the cage is in rotation is provided and by utilizing this arrangement the rods are shifted until the desired effect is produced.



Peggy—"Daddy what did the Dead Sea die of?"

Daddy—"Oh, I don't know, dear."

Peggy—"Daddy, where do the Zepelins start from?"

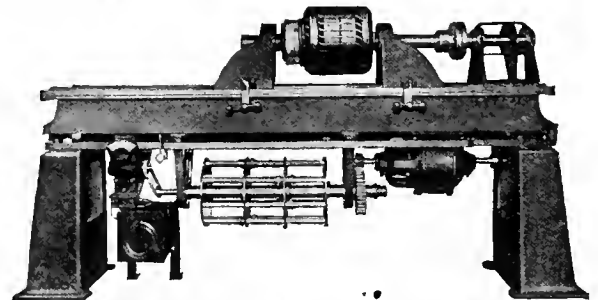

DYNAMIC BALANCING MACHINE.

Daddy—"I don't know, dear."

Peggy—"Daddy, when will the war end?"

Daddy—"I don't know."

Peggy—"I say, Daddy, who made you an editor?"

The MacLean Publishing Company

LIMITED

(ESTABLISHED 1888)

JOHN BAYNE MACLEAN - - - - - President
H. T. HUNTER - - - - - Vice-President
H. V. TYRRELL - - - - - General Manager

PUBLISHERS OF

CANADIAN MACHINERY AND MANUFACTURING NEWS

A weekly newspaper devoted to the machinery and manufacturing interests.

PETER BAIN, M.E., Editor. R. G. NEWTON, Manager.
Associate Editors.

A. G. WEBSTER, J. M. WILSON, J. H. RODGERS.

Office of Publication, 143-153 University Avenue, Toronto, Ont.

Vol. XVII.

FEBRUARY 8, 1917

No 6.

IMPAIRED STEEL PRODUCTION

ASIDE from the war news of the past week, steel, whether relative to its commercial importance or stock market standing, continues to play fast and loose with both reason and calculation. Germany's note of "frightfulness" has naturally had some effect on a situation already sufficiently acute; at the same time, we may not lose sight of the fact of its being but an incident in a day's happenings. The output of steel, both for munitions and commercial requirements, tends toward further restriction, and indications are that still lower records are in sight in the immediate future. Coke, a front rank essential in the production of steel, is both high in price and scarce, the two being interdependent. The scarcity is, however, largely due to congested transportation facilities, which appear to be growing steadily, although perhaps imperceptibly worse. What is true of the steel situation as a whole on the North American continent is equally so of that more specifically Canadian, although such concerns as the Steel Company of Canada and Algoma Steel Corporation are perhaps most directly affected in the matter of fuel for metallurgical purposes. It should, of course, be borne in mind that no small contributory to the railroad congestion prevailing is the circumstance of our being meantime in the grip of mid-winter storms and frosts, each of which contributes its quota to the magnification of other disabilities incidental to an altogether abnormal time.

Steel for shells may be said to still constitute by far the major portion, if not practically the total output of more than one of our four big steel plants. It is understood, however, that neither of them are producing the scheduled quantity, largely because of the highly abnormal transportation situation which has been allowed to develop and become a menace to our metal-working industries generally, whether munitions-engaged or otherwise. We are, of course, importing steel from the United States, but, even from that source, transportation troubles militate against even moderately prompt receipts. Our finishing plants, as a result, are in many cases operating below their rated capacity.

As an example of the extreme acuteness of the steel situation, particularly as regards munitions requirements, it may be stated that considerable credence was placed in an early-week report of action taken by the Imperial Munitions Board relative to modification of the urgency of the steel requirements—shapes, for the \$90,000,000,

one-time known "mystery block" at corner of Yonge and College Streets, Toronto. The action taken was imaginary, just as is the "mystery" regarding the concern about to erect the "block" or departmental store. This latter, we might state, will be both costly and pretentious when wholly complete as planned, involving as it does a capital outlay of \$90,000,000, covering an area bounded north and south by College and Hayter Sts., and east and west by Yonge and Terauley Streets, and rising to a height of 15 storeys. One unit only of 9 storeys, constituting about one-sixth of the structure at that height, and involving an expenditure of \$10,000,000, is meantime to be erected, and for this the steel is on order. Actual construction is not being pushed, however, a circumstance amply borne out, when it is known that delivery of steel (Bethlehem) is entirely at mill convenience; that rolling is not expected to begin until July of this year, and erection under the most favorable general conditions until July, 1918.

Steel is, nevertheless, scarce, and as an instance of how imperative are the requirements for munitions, it may be stated that two Canadian corporations specializing in both heavy, medium and light forgings, in addition to other products, finished and semi-finished, have had to decline tenders for the supply of forgings incidental to the requirements of our marine engineering and ship-building plants. The forgings in question have had, as a result, to be imported from the United States.

The downward trend in market values of Canadian steel stocks may be reckoned as healthful, whether "Peace with Victory" for Britain and her Allies be imminent or otherwise. Profits on munitions production are comparatively lean, whatever the particular line or lines being manufactured, and we look to see the price recession reach rock-bottom foundation well in advance of a cessation of hostilities. Under such circumstances, and only so, will the peace time readjustment period be brief, and abnormal dislocation of industrial enterprise in Canada be avoided.



HELP TO WIN THE WAR

THOSE who cannot go to the Front can help in a most practical way by saving their money and placing it at the disposal of the Government to assist in financing the war. The new War Savings Certificates which have been created by the Government to encourage thrift and economy, and to give everyone an opportunity to assist in financing our war expenditure, are now on sale at every bank and money order post office in Canada. The \$25 certificate sells for \$21.50, the \$50 for \$43, and the \$100 for \$86. As an investment, these certificates offer many attractive features—chief of which are the absolute security and the excellent interest return. For every \$21.50 lent to the Government now, \$25 will be returned at the end of three years.

There are two other features which are especially interesting to small investors. First, the certificates may be surrendered at any time, if the buyer should need his money; and second, each certificate is registered at Ottawa in the buyer's name and, if lost or stolen, is, therefore, valueless to anyone else. Notwithstanding their excellence from an investment standpoint, the certificates should appeal strongly to our people, because they offer to those who must needs remain at home a splendid opportunity for a most important patriotic service. The person who honestly saves to the extent of his ability and places his savings at the disposal of the Government by purchasing these certificates, may feel that he is having a direct share in feeding, equipping, and munitioning our Canadian soldiers, who are so nobly doing their part on our behalf and that of world freedom.

BOILER TUBES.

Size.	Seamless	Lap-welded
1 in.	\$30 00	
1½ in.	30 00	
1½ in.	30 00	24 00
2 in.	29 00	21 00
2 in.	33 00	20 00
2½ in.	33 00	
2½ in.	35 75	26 50
3 in.	55 00	31 00
3½ in.	54 50	36 00
3½ in.	59 50	39 00
4 in.	75 00	49 00

Prices per 100 feet, Montreal and Toronto.

OILS AND COMPOUNDS.

Castor oil, per lb.	25
Royalite, per gal., bulk	12
Machine oil, per gal.	25½
Black oil, per gal.	12½
Cylinder oil, Capital	45½
Cylinder oil, Acme	36½
Standard cutting compound, per lb.	0.6
Lard oil, per gal.	1.45
Union thread cutting oil antiseptic	68
Acme cutting oil, antiseptic	37½
Imperial quenching oil	39½
Petroleum fuel oil	12

BELTING—NO. 1 OAK TANNED.

Extra heavy, single and double	30-50%
Standard	40%
Cut leather lacing, No. 1.	\$1 50
Leather in sides	1 30

TAPES.

Chesterman Metallic, 50 ft.	\$2 00
Lufkin Metallic, 603, 50 ft.	2 00
Admiral Steel Tape, 50 ft.	2 75
Admiral Steel Tape, 100 ft.	4 45
Major Jun. Steel Tape, 50 ft.	3 50
Rival Steel Tape, 50 ft.	2 75
Rival Steel Tape, 100 ft.	4 45
Reliable Jun. Steel Tape, 50 ft.	3 50

WASTE.

White Cents per lb.

XXX Extra	20
Peerless	20
Grand	19
Superior	19
X L C R	18
Atlas	18
X Empire	18
Ideal	17
X press	16

COLORED.

Lion	14½
Standard	13
No. 1	13
Popular	11½
Keen	10½

WOOL PACKING.

Arrow	25
Axle	20
Anvil	15
Anchor	11

WASHED WIPERS.

Select White	12
Mixed colored	10
Dark colored	09

This list subject to trade discount for quantity.

RUBBER BELTING.

Standard	50%
Best grades	30%

ANODES.

Nickel	.50 to .54
Cobalt	1.75 to 2.00
Copper	.44 to .46
Tin	.49 to .56
Zinc	.23 to .25

Prices Per Lb.

COPPER SHEETS.

	Montreal	Toronto
Bars, ½ to 2 in.	\$46 00	\$46 00
Plain sheets, 14 oz.		
14x28 in., 14x60 in	45 00	45 00
Copper sheet, tinned, 14x60, 14 oz.	54 00	54 00
Copper sheet, plain, 14x60 base.	57 00	57 00
Braziers' in sheets, 6x4 base	46 50	46 50

BRASS.

Brass rods, base ½ in to 1 in rd.	0 55
Brass sheets, 8 in. wide, 20 oz.	0 60
Brass tubing, seamless.	0 55
Copper tubing, seamless.	0 55

PLATING SUPPLIES.

Polishing wheels, felt.	2 10
Polishing wheels, bull-neck	1 35
Emery in kegs, American	06
Emery, ground	04
Emery glue	15 to 20
Tripoli composition	04 to 06
Crocus composition	07 to 08
Emery composition	08 to 09
Rouge, silver	35 to 50
Rouge, powder	30 to 35

Prices Per Lb.

LEAD SHEETS.

	Montreal	Toronto
Sheets, 3 lbs. sq. ft.	\$12 90	\$12 50
Sheets, 3½ lbs. sq.		

ft.	11 75	12 25
Sheets, 4 to 6 lbs. sq. ft.	11 50	12 00
Cut sheets, ½ lb. per lb. extra		
Cut sheets to size, 1c per lb. extra.		

PLATING CHEMICALS.

Acid, boracic	\$ 15
Acid, hydrochloric	.05
Acid, hydrofluoric	.14½
Acid, nitric	.10
Acid, sulphuric	.05
Ammonia, aqua	.08
Ammonium carbonate	.15
Ammonium chloride	.11
Ammonium hydrosulphuret	.40
Ammonium sulphate	.07
Arsenic, white	.12
Copper, carbonate, anhyd.	.35
Copper, sulphate	.17
Cobalt sulphate	.70
Iron perchloride	.20
Lead acetate	.16
Nickel ammonium sulphate	.12
Nickel carbonate	.35
Nickel sulphate	.15
Potassium carbonate	.75
Potassium sulphide (substituted)	.20
Silver chloride (per oz.)	.65
Silver nitrate (per oz.)	.55
Sodium bisulphite	.10
Sodium carbonate crystals	.65
Sodium cyanide, 127-130%	.41
Sodium hydrate	.04
Sodium hyposulphite, per 100 lbs.	5.00
Sodium phosphate	.14
Tin chloride	.60
Zinc chloride	.60
Zinc sulphate	.60

Prices Per Lb. Unless Otherwise Stated.

The General Market Condition and Tendency

THE industrial situation has been materially affected by the breaking-off of diplomatic relations between the United States and Germany, and further developments are being awaited with interest. The effect, so far, has been most noticeable in the ingot metal markets, where prices have advanced on copper, tin and antimony. The advance in tin, however, is due more to the possibility of shipments being lost on account of the proposed submarine blockade and not because of the likelihood of an increase in demand, as in the case of copper and antimony. Steel prices continue on the up-grade, iron and steel bars, plates and shapes all having reached higher levels. The steel market is very strong, and the recent developments in the international situation will tend to further strengthen the situation. The output of the mills is still being curtailed on account of the difficulty in obtaining supplies of coke and raw material in sufficiently large quantities. In this regard the outlook in the meantime is not very bright, although a strenuous effort is being made to relieve the congestion of freight by the railways. Canadian foundry pig-iron continues off the market and a considerable tonnage is now being imported from the United States. The machine tool market is quiet, pending the placing of third and fourth quarter contracts for munitions.

Montreal, Feb. 5.—The rupture of diplomatic relations between the United States and Germany has had a disturbing effect upon the entire industrial situation. Early future conditions will be largely indicated by developments of the next few days. Freight congestion and embargoes are causing considerable inconvenience and many factories are seriously handicapped through non delivery of much-needed material.

Pig Iron

Railroad embargoes are seriously affecting the pig iron situation and poor

delivery of raw materials makes it very difficult to maintain maximum production. The chief factor in the situation is the coke shortage, furnaces being forced to operate light or suffer temporary shut down.

Foundries are also handicapped for the same reason and prospects of early relief are not very encouraging. One local foundry paid as high as \$20 per ton for sufficient coke to make a certain casting, being unable to secure delivery on several cars held up a few miles from Montreal.

Steel

A new condition is likely in the steel situation, following the developments of the past few days and those that will take place during the coming week. The market continues very strong and comparatively steady under the tension that prevails throughout all branches of industry. Nervousness is not pronounced but the trade is anxiously awaiting definite action on the part of the U.S. government in respect to the latest crisis in international relations. That the next week or two will mark an important period in the year's history is more than possible, but at the moment it would be premature to reflect upon early future conditions. The steel situation at present is seriously affected by the difficulties experienced in transportation of materials, railroad embargoes and weather conditions interfering with the satisfactory shipments of all classes of raw and finished material. While a declaration of war on the part of the United States would probably mean increased activity in the steel industry with a corresponding advance in cost of material, a relaxation of the contemplated submarine warfare would have little effect upon present conditions, owing to the abnormal activity that is promised for more than a year hence. With the exception of rolling billets and blue annealed sheets, both of which show advances, the market is unchanged and prices remain firm. Local dealers report the situation as firm as usual, but anticipate some interesting changes, should developments force the United States to take the steps which generally follow a diplomatic break.

Metals

The general market is again featured by activity in some of the metals, with the coming week promising still further developments, the extent of which is at present very uncertain. The metals are very strong with copper steady but unchanged. Tin shows a sharp advance owing to sea risks. Spelter is quiet following a short active period. Lead is stronger while antimony is shooting upwards. Aluminum is active and very firm.

Copper.—The market is still unsettled awaiting the outcome of present relations between the United States and Germany. The underlying tone of the situation is very indefinite, and unsettled conditions will likely prevail for some little time until conditions develop further. Copper is comparatively strong but the future is uncertain. Strength has been added to the London market, while New York reports little change. The local situation is steady with prices firm and unchanged.

Tin.—The sharp advance on London market has been followed by a further rise in New York the quotation being now 51½ cents. In view of the present outlook, and contingent risks on tin shipments, local dealers are now quoting 56 cents per pound on a fairly active market; this is an advance on the week of 8c per lb.

Spelter.—The recent strength shown in spelter attracted sellers to the extent of offering a larger volume of metal than the trade could absorb, with the result that the market reacted to a lower level. The New York market which last week advanced ¾c shows a decline of one cent the week, the current quotation being 93¼c per lb. Dealers here however are quoting 15c, an advance on the week of ½ cent per lb.

Lead.—The leading interests have placed their nominal quotation on a basis of 8c. This is ½ cent higher than last week, and the situation has taken on a serious aspect owing to the fact that consumer's supplies are low, and considerable doubt exists as to the whereabouts of metal in transit. The existing uncertainty of early future conditions does not tend to relieve the situation and further strength with increased prices is not improbable. The trust price is now 8c with independents asking 8½c. The local market is active and stronger, the dealers having advanced their quotations to 11c, this being ½ cent above last week.

Antimony.—The market is still featured by the active upward movement of antimony. This strength is largely due to the delays in shipments of metal, but U.S. war possibilities may be a factor in the remarkable return to high tide during the past few weeks. Following the advance of last week, New York announces a further advance of 4c, the nominal price now asked being 25c per lb. Canadian requirements are heavy and possible developments on the other side might curtail the early future sup-

ply so that further strength may be expected. The week's advance shows an addition of 7c, the present local price being 25 cents per pound.

Machine Tools and Supplies

Business in machine tools continues satisfactory but the volume is not heavy. Orders for single tools are still fairly active but builders are looking forward to additional activity when further shell contracts are placed. Firms making shells are fully occupied, and additions to plant capacity mean the constant placing of new machines. Several local firms are taking over buildings and increasing their output. One plant here is purchasing 35 special machines as an addition to their present equipment which will increase their output over 100 per cent.

Scrap

In common with other markets, old materials are affected by uncertain conditions. At present the situation is marked by nervousness; with the most recent tendency showing an upward movement in price quotations. New York prices are generally higher and local dealers are slightly in advance over last week on machine compositions, turnings and heavy lead.

Toronto, Ont., Feb. 8.—The severance of diplomatic relations between the United States and Germany affects Canada closely, but what the future holds for this country in this regard is difficult to determine. Developments will be watched, however, with intense interest, especially as they affect the steel trade, metal markets, and machine tool business, more particularly in regard to the munitions industry. The fact that the U. S. would be an ally would minimize any adverse effect produced by the situation. There has been some improvement made during the week in the freight situation, but the severe weather has hampered the railways in their efforts to relieve the congested conditions.

Steel

The latest development in the international situation will tend to strengthen the steel market. Whether the United States are actually drawn into the conflict or not, the preparedness policy advocated some time ago will likely be put in effect. This would entail a further demand for steel at a time when the mills have heavy commitments. As Canada is not at the present time entirely independent of the U. S. mills, the outlook here is somewhat uncertain, as there is a possibility of supplies of steel from the States being partially cut off. Such a contingency, whether remote or otherwise, should be considered, as the effect would be more or less serious in view of the enormous demand for steel for our munitions and the meantime inadequate output of our mills. In any event, continued upward movement in prices seems inevitable, and indications of this may be seen in a further advance in iron and steel bars, plates and small shapes, which are now quoted as follows:—Iron bars, 4c; steel bars, 4.25c;

shapes, 4.75c; and plates, 5.85c per pound. Production is still running behind the tonnage anticipated, as deliveries of raw materials are slow on account of transportation difficulties, accentuated by the severe weather. Two fair-sized orders for structural steel have been placed recently. The Dominion Bridge Co. has been awarded 13,000 tons for the new departmental store—"Mystery Block," Toronto, Bethlehem shapes being specified, and the Imperial Munitions Board has placed an order for 2,500 tons of shapes with the Hamilton Bridge Works for the new steel plant at Ashbridge's Bay.

Prices of black sheets are very firm, and the demand in the primary markets continues very heavy, particularly for blue annealed material. The sheet mills are badly handicapped by the scarcity of raw material and fuel, and production is being curtailed. There have been no price changes on either black or galvanized sheets, but higher prices are expected any time. Canada plates, bright, have advanced to \$7.50 per 100 lbs.

The situation in the steel trade in the States is one of watchful waiting, pending developments. Demand has just begun to improve following the set-back caused by peace talk; now new buying has been again suspended temporarily. Prices, however, show no indication of weakness and the upward movement in values is expected to continue. The only important advance to note is in forging billets, which are now \$85 per ton.

Pig Iron

There is really no change in the pig iron situation. Canadian foundry iron is still off the market, and there is no prospect of supplies being obtainable until there is sufficient coke available for the furnaces to operate. Coke is still a very scarce commodity, notwithstanding efforts made by the railway companies to relieve the situation. A considerable tonnage of pig iron is being imported from the States.

Scrap

The market is very firm and prices generally have an upward tendency. Copper wire and No. 1 machine composition are both higher, while other copper scraps will undoubtedly advance. Lead and zinc have also advanced about 1c per pound. Although the embargo on steel turnings has been lifted, prices are higher, this material being now quoted at \$9.

Machine Tools

The recent development in the States is being watched with interest in local machine tool circles. If the U. S. Government find it necessary to take over munition plants for their own requirements, some difficulty may be experienced in getting machine tools from the States into Canada. Apart from this, business is quiet except for a fair demand for single tools. Canadian machine tool builders continue very busy on munitions equipment, which is not confined to domestic trade, as some export business is being done also.

Supplies

Prices continue very firm on all lines of machine shop supplies, but comparatively few changes have been made during the week. Manila rope, however, has advanced 2½¢, and is now quoted at 29½¢, while transmission rope and drilling cables are quoted at 37½¢ and 32½¢ respectively. Grindstones have advanced 45¢ per 100 lbs.

Metals

The possibility of the United States taking an active part in the war has caused considerable excitement in the metal markets. The proposed German submarine blockade has also affected the markets, but this is a passing feature, as it is not very probable that shipments of metals will be seriously interfered with. Prices of some metals have already advanced, copper, tin, and antimony having all been affected. In all these cases, however, prices are entirely nominal.

Copper.—The market is excited on account of the war situation, but prices although higher, are nominal. There is practically no copper to be had for near-by delivery, as dealers who have metal are holding and awaiting developments. There is very little copper for delivery sooner than August to be had; this will have a tendency to keep the market firm. Copper has advanced 2¢ locally, and is now quoted nominally at 38¢.

Tin.—The submarine blockade proposals have made the tin market nervous on account of the possibility of shipments of this metal being lost and available supplies diminished. The scare has sent prices forward sharply, but at the same time buying is restricted. Tin has advanced 10¢ locally, and is nominally quoted at 58¢ per pound.

Spelter.—Along with other metals, the spelter market is unsettled, but quotations are unchanged. Consumers are not in the market at all, while producers are adopting an attitude of waiting for further developments. Local price, 13½¢ per pound.

Lead.—The market has not been disturbed by recent developments, and the situation in lead is more favorable than in other metals. The "Trust" is now quoting 8¢ and "Independents" 8.25¢ to 8.75¢ New York. Local price unchanged at 10¢ per pound.

Antimony.—The market has been upset by the recent international developments and prices have advanced. Although antimony would not be affected by submarine operations, the outlook is unsettled. Antimony has advanced 6¢ locally, and is now quoted at 26¢ per pound.

Aluminum.—The market is firmer, but quotations are unchanged at 68¢ per pound.

Solders.—Prices have been affected by the advance in tin and continued high cost of lead. Current quotations are 6¢ higher, guaranteed being quoted at 35¢ and strictly at 33¢ per pound.

CANADA'S LAST FISCAL YEAR

THE public accounts for the last fiscal year were tabled in the House of Commons, Ottawa, on February 1, by the Minister of Finance. Total receipts on account of consolidated fund were \$172,147,838, while the total expenditure for the ordinary expenses of administration amounted to \$130,350,726. The surplus was, therefore, \$41,797,112. Capital account expenditure totalled \$38,566,950 on public works, including \$7,078,000 on the National Transcontinental; \$7,635,000 on the Intercolonial; \$4,887,000 on the Hudson Bay Railway, and \$4,909,000 on the Welland Ship Canal. The railway subsidies paid during the year totalled \$1,400,000. The war expenditure was \$166,197,753. The total expenditures under all headings were \$209,350,000. The increase in net debt of the Dominion was \$165,780,000, or practically the same as the amount set down for war expenditure.

Under the heading of war expenditure, the Militia and Defence Department was responsible for \$160,433,000, the Justice Department for \$1,287,000, the Naval Department for \$3,274,000, and the Dominion Police for \$201,000.

CANADIAN GOVERNMENT PURCHASING COMMISSION

The following gentlemen constitute the Commission appointed to make all purchases under the Dominion \$100,000,000 war appropriation:—George F. Galt, Winnipeg; Hormidas Laporte, Montreal; A. E. Kemp, Toronto. Thomas Hilliard is secretary, and the Commission headquarters are at Ottawa.

Pay allowances and sustenance of the troops cost \$100,788,000, transport \$8,686,000, clothing \$13,194,000, small arms and ammunition \$7,766,000. The war expenses of the Justice Department include, of course, the cost of looking after the interned prisoners.

The consolidated fund expenditure for the fiscal year ended March last was a little over \$5,000,000 less than the expenditure for 1915. The capital account expenditure decreased by nearly three millions. The details of receipts and expenditures show the huge transactions which the Canadian Government has put through for the Allied Governments in connection with war purchases for Canada. There was received from the Imperial Government during the twelve months \$148,000,000, while there was expended on the Imperial Government account \$186,000,000. From the French Government there was received \$1,670,000, and expenditures on French account totalled \$2,018,800. Russian and Italian Governments receipts and expenditures handled by the Canadian Government totalled about \$1,000,000 each, while for the New Zealand Government, Canada spent nearly four million dollars.

One of the interesting items of the details of receipts is the acknowledgment of conscience money to a total of \$371 by the Customs Department, \$102 by the Finance Department, and \$99 by the Marine Department.

CANADA'S NEW BORROWINGS

THE resolution of Sir Thomas White calling for legislation authorizing the Government to borrow \$100,000,000 to meet maturing obligations of the Dominion, to carry on public works and to meet expenditures for general purposes, was adopted in the House of Commons, Ottawa, on February 1, and the bill based upon it was introduced. The Finance Minister during the discussion intimated that a considerable portion of any money which might be borrowed under the provisions of the bill would be obtained by domestic loans. He said he would like to float all loans in Canada, but pointed out that the condition of exchange might make it desirable to borrow in the United States.

He told the House that Canada's revenue for the present fiscal year would be sufficient to pay all ordinary and capital expenditures of the country and sixty or seventy million dollars of the principal of its war expenditure. He estimated that during the coming year it would be necessary to borrow \$250,000,000 on this side of the Atlantic to meet war expenditures and additional sums to establish credits for Great Britain in the Dominion. Balancing the advances made by Canada to the Imperial Government to pay for munitions manufactured here, against the sums owing by Canada to the Imperial Government for supplies for the Dominion's troops overseas, he concluded that Great Britain was now indebted to Canada to the extent of \$18,000,000.

ONTARIO LABOR BRANCH RETURNS

"WE are now getting the class of people we were after," says Dr. Riddell, superintendent of the Trades and Labor Branch Department of Public Works, Province of Ontario. "We make no attempt to handle the casual labor where work is obtained for a day or two. We are now in a position to handle skilled labor and we have got that class coming to the office. The Ottawa office shows probably the lowest cost per capita for placements of any place that I know of except one. There, for the month of January, it has been 46¢. Wisconsin is down to 45¢, and that's the lowest I know."

During January there were applications for work by 2,150 men and 1,130 women, while 700 employers sent in applications for help. There were placed 769 males and 121 females. These are the total figures for all the different bureaus in Ontario. The Bureau placed during the month the following:

Farm hands	3
Building trades	85
Clerical work	25

Enlarged Canadian Trade Intelligence Service

Under the arrangement made by the Minister of Trade and Commerce with Sir Edward Grey in July, 1912, the Department of Trade and Commerce, Ottawa, is able to present the following list of the more important British Consulates whose officers have been instructed by the Foreign Office to answer inquiries from and give information to Canadians who wish to consult them in reference to trade matters.

BRAZIL—Bahia, British Consul. Rio de Janeiro, British Consul General.	NETHERLANDS—Amsterdam, British Consul.
CHILE — Valparaiso, British Consul General.	PANAMA—Colon, British Consul. Panama, British Vice-Consul.
COLOMBIA — Bogota, British Consul General.	PERU—Lima, British Vice-Consul.
ECUADOR—Quito, British Consul General. Guayaquil, British Consul.	PORTUGAL—Lisbon, British Consul.
EGYPT — Alexandria, British Consul General.	RUSSIA—Moscow, British Consul General. Petrograd, British Consul. Vladivostok, British Consul. Odessa, British Consul General.
FRANCE—Havre, British Consul General. Marseilles, British Consul General.	SPAIN—Barcelona, British Consul General. Madrid, British Consul.
INDIA—Calcutta, Director General of Commercial Intelligence.	SWEDEN—Stockholm, British Consul.
ITALY—Genoa, British Consul General. Milan, British Consul.	SWITZERLAND—Geneva, British Consul.
MEXICO—Mexico, British Consul General.	URUGUAY—Monte Video, British Vice-Consul.
	VENEZUELA — Caracas, British Vice-Consul.

Canadian Commercial Intelligence Service

The Department of Trade and Commerce invites correspondence from Canadian exporters or importers upon all trade matters. Canadian Trade Commissioners and Commercial Agents should be kept supplied with catalogues, price lists, discount rates, etc., and the names and addresses of trade representatives by Canadian exporters. Catalogues should state whether prices are at factory point, f.o.b. at port of shipment, or, which is preferable, c.i.f. at foreign port.

CANADIAN TRADE COMMISSIONERS.

ARGENTINE REPUBLIC—H. R. Poussette, Reconquista, No. 46, Buenos Aires. Cable address, Canadian.
AUSTRALIA—D. H. Ross, Stock Exchange Building, Melbourne. Cable address, Canadian.
BRITISH WEST INDIES—E. H. S. Flood, Bridgetown, Barbadoes, agent also for the Bermudas and British Guiana. Cable address, Canadian.
CHINA—J. W. Ross, 13 Nanking Road, Shanghai. Cable address, Cancom.
CUBA—Acting Trade Commissioner, Lonja del Comercio, Apartado 1290, Havana. Cable address, Cantracom.
FRANCE—Phillipe Roy, Commissioner General, 17 and 19 Boulevard des Capucines, Paris. Cable address, Stadacona.
JAPAN—G. B. Johnson, P. O. Box 109, Yokohama. Cable address, Canadian.
HOLLAND—Acting Trade Commissioner, Zuidblaak, 26, Rotterdam. Cable address, Watermill.
RUSSIA—C. F. Just, Canadian Government Commercial Agent, Alexandriyskaya, Ploshch 9, Petrograd. L. D. Wilgress, Canadian Government Commercial Agent, Bukhgozla Ulitza No. 4, Omsk, Siberia.
NEWFOUNDLAND—W. B. Nicholson, Bank of Montreal Building, Water Street, St. John's. Cable address, Canadian.
NEW ZEALAND—W. A. Beddoe, Union Buildings, Customs Street, Auckland. Cable address, Canadian.
SOUTH AFRICA—W. J. Egan, Norwich Union Buildings, Cape Town. Cable address, Cantracom.
UNITED KINGDOM—Harrison Watson, 73 Basinghall Street, London, E.C., England. Cable address, Sleighing, London. N. D. Johnston, Sun Building, Clare Street, Bristol. Cable address, Canadian. J. E. Ray, Central House, Birmingham. Cable address, Canadian. J. Forsyth Smith, 27-28 Pearl Building, East Parade, Leeds. Cable address, Canadian. F. A. C. Bickerike, Canada Chambers, 36 Spring Gardens, Manchester. Cable address, Cantracom. J. T. Lithgow, 87 Union Street, Glasgow, Scotland. Cable address, Cantracom.

SPECIAL TRADE COMMISSIONER—LUMBER

H. R. McMillan, visiting Europe, Africa, Australasia and the Orient.

CANADIAN COMMERCIAL AGENTS

AUSTRALIA—B. Millin, Exchange Building, Sydney, N.S.W.
BRITISH WEST INDIES—Edgar Tripp, Port of Spain, Trinidad. Cable address, Canadian. R. H. Curry, Nassau, Bahamas.
NORWAY AND DENMARK—C. E. Sontum Grubbege No. 4, Christiania, Norway. Cable address, Sontums.

CANADIAN HIGH COMMISSIONER'S OFFICE

UNITED KINGDOM—W. L. Griffith, Secretary, 17 Victoria Street, London, S.W., England. Cable address, Dominion, London.

Laborers	72
Munition workers	371
Metal workers, etc.	28
Miscellaneous	43

During January the applications for work from the different bureaus were: Toronto, 626 males, 935 females; Ottawa, 1,377 males and 16 females; Hamilton, 96 males, 489 females. Compared with December there were fewer applications last month and fewer placements in Toronto. The figures are:

	Dec. 1916.	Jan. 1917.
Applications	2,256	1,561
Placements	214	168

PULPWOOD SHORTAGE

A SERIOUS shortage of pulpwood in Canada during the coming year was predicted by J. A. Bothwell, of the Brompton Pulp and Paper Co., chairman of the Mechanical Pulp Section of the Canada Pulp and Paper Association, at their annual meeting in the Ritz Carlton at Montreal on January 31. The shortage will be of such extent, he continued, that the paper mills purchasing the entire wood supply are going to find themselves shut down for want of pulpwood by September 1, 1917.

That paper manufacturers had not raised prices to an unjust level, although they had made substantial profits last year, after many bad years, was the contention of C. Howard Smith, acting president. He called for standardization of lines, variety, shades and weights. Many lines were being imported that should be made in Canada.

RAILWAY MATERIAL PRICES

RAILWAY executives declare that the steady increase in the price of materials used in large quantities on the railways presents a serious problem.

Figures quoted by one of the officers of the Grand Trunk System show that many of the staple products used by the line have more than doubled in price during the last year. Brass has increased over two hundred per cent. in price, and the railway uses more than a million dollars' worth of this metal each year.

Copper has risen over one hundred per cent. in value, while steel bars, plates, angles, etc., hundred of tons of which go into railway maintenance each year, are costing three times as much as they did before the war and delivery is difficult to obtain.

Springs for engines and cars are other items which require to be constantly replaced, and these have increased in price about one hundred and eighty-five per cent.

A type of locomotive which two years ago could have been bought for twenty-seven thousand dollars cannot be ordered for future delivery at any figure under forty-five thousand dollars.

The Storey Pump & Equipment Co., Toronto, have been awarded a contract for a gasoline engine and pump by the town of St. Mary's, Ont.

Immediate Shipment

LEBLOND LATHES IN STOCK.

- 3—16" x 6' double back gear, quick change
- 2—17" x 6' heavy duty, double back gear, quick change
- 2—17" x 8' heavy duty, double back gear, quick change
- 1—20" x 8' single back gear, quick change
- 5—25" x 10' heavy duty, double back gear, quick change

LEBLOND LATHES FOR QUICK SHIPMENT

- 4—19" x 8' heavy duty, double back gear, quick change
- 6—19" x 10' heavy duty, double back gear, quick change
- 6—21" x 8' heavy duty, double back gear, quick change

RAHN LARMON LATHES IN STOCK.

- 6—16" x 6' double back gear, quick change, cabinet legs

CISCO LATHES FOR IMMEDIATE SHIPMENT.

- 3—14" x 6' quick change with taper attachment

- 3—14" x 6' quick change with taper, draw-in and relieving attachments, and oil pan

- 3—16" x 6' quick change

- 3—16" x 8' quick change

SHAPERS IN STOCK

- 1—24" Gould & Eberhardt, heavy duty
- 2—24" Gould & Eberhardt with 28" stroke
- 2—24" Milwaukee heavy duty

SCREW MACHINES IN STOCK.

- 6—No. 6 Warner & Swasey, geared friction head, power feed to turret

MILLING MACHINES.

- 1—No. 3 Cincinnati, Universal, practically new
- 2—No. 2 Garvin, Universal, new
- 1—No. 25 Becker, plain, new

The A. R. Williams Machinery Company, Limited

64-66 Front Street West, Toronto, Ontario, Canada

Give Him a Chance

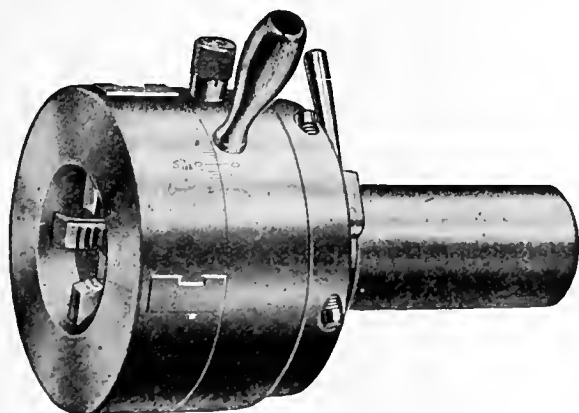

Give the man who has to do the work a chance to say what tools give best results, and then give him the best.

Among all the users of Geometric threading dies, a dissatisfied man has not been found.

We have a Geometric Self-Opening and Adjustable Screw-Cutting Die Head for you, also, and want you to have it.

Geometric Die Heads can be arranged for use on any make of Screw Machine or Turret Lathe.

Let us know the requirements of your thread-cutting operations, and we will send you full particulars of the most suitable Die Head.

The Geometric Tool Co. - - New Haven, Conn.

Canadian Agents: Williams & Wilson, Limited, Montreal
The A. R. Williams Machinery Co., Ltd., Toronto, Winnipeg, St. John, N.B.

If any advertisement interests you, tear it out now and place with letters to be answered.

INDUSTRIAL ^A_N^D CONSTRUCTION NEWS

Establishment or Enlargement of Factories, Mills, Power Plants, Etc.; Construction of Railways, Bridges, Etc.; Municipal Undertakings; Mining News

ENGINEERING

St. John, N.B.—The Nashwaak Pulp & Paper Co. will extend their mill.

Fergus, Ont.—Beatty Bros. are buying power house and foundry equipment.

Winnipeg, Man.—The Board of the General Hospital is considering building a power plant.

Montreal, Que.—Fire recently gutted the machine shop of J. K. McDonald, 318 West Craig street.

Edmundston, N.B.—Fraser's, Ltd., have selected a site here for its proposed pulp and paper mill.

Toronto, Ont.—The Imperial Munitions Board will build a forging plant and a machine shop in connection with the steel plant at Ashbridge's Bay.

Toronto, Ont.—Canadian Aeroplanes, Ltd., will shortly commence construction of a factory on Dufferin street. Jackson, Lewis Co., Toronto, are the contractors.

Toronto, Ont.—It is announced that a new aviation school will be established at Camp Borden at an estimated cost of \$3,000,000. The plans include an aerodrome, hangers and machine shop.

Chatham, Ont.—Negotiations have been completed between the Chatham Bridge Co. and the Pittsburg Steel Co., whereby the plant of the former company will be taken over and operated by the Pittsburg concern.

Toronto, Ont.—British Forgings, Ltd., have taken out a permit to put in foundations for an electric plant at the foot of Cherry Street, near the Harbor Commission's ground area at a cost of \$25,000, for the Imperial Munitions Board.

Winnipeg, Man.—The Greater Winnipeg Water District has ordered Thomas Kelly & Sons to add a considerable quantity of machinery, plant and equipment to that already in place upon their contract, so as to secure completion of the work within specified time.

Winnipeg, Man.—The Greater Winnipeg Water District Board has authorized the commissioners to call tenders for cast iron pipes, valves and specials for the pipe line between the Red River and McPhillips Street reservoir. The estimated cost is about \$250,000.

Halifax, N.S.—The coal mine at Port Hood, which has for some time been idle, is to be re-opened and operation will soon be on an extensive scale. The mine has good equipment for an output of two thousand tons per day. The Green Wood Coal Co., now operating at Thornburn, Pictou County, has taken over the mine.

Vancouver, B.C.—John Coughlan & Sons have taken out a building permit for the erection of what practically com-

prises the first unit of the firm's new shipyards on False Creek. The permit which was issued by City Building Inspector R. A. McKenzie, provides for the erection of the machine shops and mould loft.

MUNICIPAL

Cayuga, Ont.—Extensions to the waterworks system are contemplated and will include pumps, cast iron pipe, water tank, etc.

Brantford, Ont.—Fire Chief Lewis has recommended the purchase of a motor tractor for an aerial truck and a new gasoline motor pump.

Chatham, Ont.—A by-law will be submitted to the ratepayers on February 20 for the erection of a pickle factory to cost \$100,000, by Libby, McNeil & Libby, Chicago, Ill.

London, Ont.—It is reported that Hunt Bros., who operate a flour mill, may leave here and establish a factory at Fort William, Ont.

Ottawa, Ont.—Appropriations for public works for Toronto include \$1,000,000 for harbor development, \$120,000 for repairs to public buildings, and \$500,000 for postal station A.

Oakville, Ont.—The Acme Rubber Co. by-law was carried by a substantial majority. It is understood that the purchase of the Ware factory will be completed very shortly.

Hamilton, Ont.—Fire Chief Ten Eyck has asked the City Council for an appropriation of \$176,750 for the fire department. This sum includes cost of a motor aerial truck, combination motor hose and chemical wagon.

Peterborough, Ont.—The City Council have conferred with Sir Adam Beek regarding the acquiring by the city of the street railway at Peterborough, the gas plant, and the Otonabee electric distributing plant. These have been operated by the Hydro-Electric Commission for the past eight or nine months.

GENERAL

Elmira, Ont.—The Colonial Knitting Co. are considering the erection of a knitting mill.

Toronto, Ont.—The Dominion Envelope Co. will build a warehouse to cost about \$50,000.

Niagara Falls, Ont.—The American Cyanamid Co. will rebuild their plant, which was recently destroyed by fire, at a loss of \$200,000.

Galt, Ont.—No. 2 works of the Newland & Co. carding and spinning departments were practically wiped out by fire last Saturday. The loss covered by in-

surance will run into thousands of dollars.

Tillsonburg, Ont.—The Canadian Huntly Mfg. Co., which was recently incorporated has taken over the electric ear works here. C. G. Hammond of Silver Creek, N.Y., is president of the company and W. H. Bennett of Tillsonburg is vice-president.

Toronto, Ont.—Permission has been asked from the Board of Health by J. B. Harris & Co. to erect a gelatine and glue factory on the Harbor Commission industrial sites, south-east of the Don. Mr. Harris, who was present at the meeting, said his company had taken five acres of land, and about half of this would be used.

Danville, Que.—Damage to the extent of about \$40,000 was done by fire here on Jan. 29. The factory and storerooms of the Danville Chair & Specialty Co. were completely destroyed, and other sufferers were the Danville Mfg. Co., G. McCracken Flour & Feed Warehouse. About \$25,000 in insurance was carried.

TENDERS

Winnipeg, Man.—Tenders will be called until February 12 for works required for the completion of the new Parliament Buildings, which include the following:—Heating and ventilating, electric conduit and wiring. Thos. H. Johnson, Minister of Public Works, Winnipeg.

Montreal, Que.—Tenders, addressed to the Board of Commissioners, City Hall, will be received until February 9, for the supply and delivery of auto sprinkler-flushers and auto-sweepers. Copies and specifications and forms of tenders may be obtained by the interested parties at the office of the superintendent of purchases and sales, where all necessary information will be given.

Ottawa, Ont.—Tenders will be received at this office until February 12, for the supply of: Brooms and brushes, chain, coal, hardware, hose, oils and greases, packing, paint and paint oils, Manila rope, wire rope and steam pipe, valves and fittings, for the requirements of the departmental dredging plant in Ontario and Quebec during the fiscal year 1917-18. These forms of tender can be obtained at the Department of Public Works, Ottawa. R. C. Desrochers, secretary.

Winnipeg, Man.—Tenders will be received at the office of the Winnipeg Public School Board up to February 8, for supplying the following material:—Blacksmith's coal, drawing, hardware, iron, steel, lumber, oils, varnishes, electrical, printing, required in connection with the Technical and Manual Training

Aikenhead's

A.K.

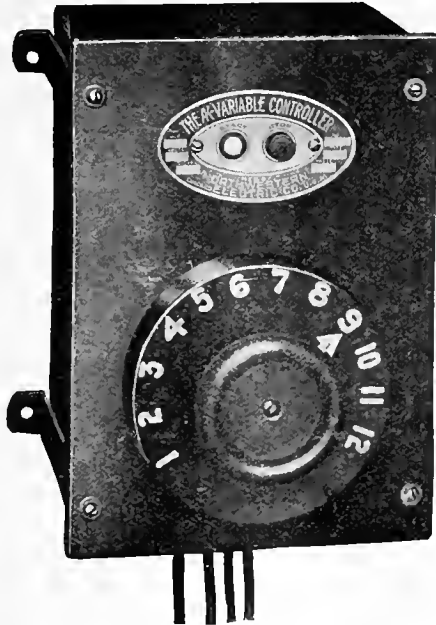

The A.K. Motors are built for high efficiency and long durability.

Single Phase, Variable Speed Type will run on 110 or 220 volt, 25 or 60 Cycle.

These come in sizes from $\frac{1}{4}$ H.P. up and are stocked, complete with a 12-speed Controller, in Toronto.

**MOTOR
AND
CONTROLLER**



Aikenhead Hardware Limited, 17, 19, 21 Temperance St., Toronto, Can.

THREE A MINUTE!

ON THE

**Morris-Thomson
Semi-Automatic Thread Miller**

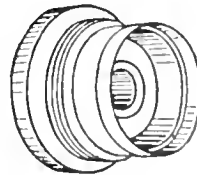
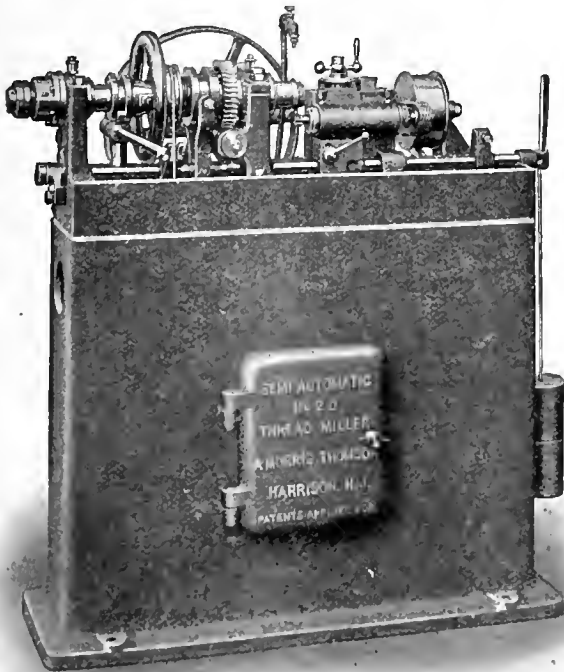

14 Pitch Whit.
1.200 in. diam.
1-4 in. long on
Bronze Primers.

Time-saving features:

Lever-operated collet chuck.
Lever-operated advance of cutter into work.
Automatic start and stop of work rotation.
Automatic withdrawal of cutter on completion of thread.
No screw adjustment to be made for each piece.
Operator has absolutely no thinking to do—levers to pull—that is all.

For full particulars of this and our larger machines with a capacity up to 12 inches diameter by 48 inches long get our new catalog.

T. C. M. Manufacturing Company, Harrison, N.J., U.S.A.

If any advertisement interests you, tear it out now and place with letters to be answered.

Schools of the city. For specifications, forms of tender, and further information required, apply direct to the Commissioner of Supplies, School Board Offices. R. H. Smith, secretary-treasurer, W. P. S. B.

Toronto, Ont.—Tenders will be received up to Feb. 12, for the supply of the following materials for the Township of York:—24 in., 12 in., and smaller sizes, east iron pipe; 24 in., 12 in., and smaller sizes of special castings; 6 in., 12 in., and 24 in. valves; air valves, hydrants, tops, covers and plugs, venturi meters and recorders; 6 in., 12 in., and 24 in. check valves. Plans and specifications may be obtained from Frank Barber, township engineer, 57 Adelaide Street West, Toronto.

Ottawa, Ont.—Tenders will be received until February 15 for the purchase of old laundry machinery, the property of the Department of Public Works, and now stored in the old Baker Laundry, Wellington Street, Ottawa. List of machinery may be obtained on application to the clerk of works, Postal Station "F," Toronto; to the overseer, Central Post Office, Montreal; and to the superintendent Dominion Buildings, Ottawa. Inspection of the machinery may be made in the premises on application to the superintendent of Dominion Buildings.

CONTRACTS

The Otis Fensom Elevator Co. have been awarded the elevator contract for the chemical factory being erected by F. W. Horner, Ltd., Montreal, to cost \$48,000.

Toronto, Ont.—The Hamilton Bridge Works, Hamilton, Ont., have been awarded the contract for the steel work for the steel plant which the Imperial Munitions Board will build on Ashbridge's Bay. The contract calls for 2,500 tons of steel.

Winnipeg, Man.—The Greater Winnipeg Water District Board has instructed Engineer Chace to prepare alternative estimates on steam and electric railways from Deacon to St. Bonifac, and also the cost of building and equipping proposed line in Transeona, including cars.

INCORPORATIONS

The International Nickel Co., have been licensed to carry on business in the Province of Ontario with a capital not to exceed \$5,000,000.

W. G. Edge Ltd., has been incorporated at Ottawa with a capital of \$900,000 to carry on business as iron founders machinists, etc., at Ottawa, Ont. The incorporators are William G. Edge, John Smith and James A. Cunningham all of Ottawa.

The Porcupine Pulp & Lumber Co., has been incorporated at Toronto with a capital of \$10,000 to manufacture pulp and paper. The head office is at Toronto and the incorporators are R. H.

Parmenter, A. J. Thomson and W. P. Morlock all of Toronto

Union Special Machine Co. of Canada, Ltd., has been incorporated at Ottawa with a capital of \$25,000 to manufacture machinery of all kinds. The head office is at Toronto and the incorporators are James S. Lovell, Charles D. Magee and William Bain all of Toronto.

The Carter Welding Co., has been incorporated at Toronto with a capital of \$40,000 to manufacture cutting and welding apparatus of all kinds at Toronto. The provisional directors are Herbert, W. Carter, Peter MacGregor Sorley and Frank S. Mearns all of Toronto.

MARINE

Ottawa, Ont.—The Government is advancing \$1,500,000 to the Quebec Harbor Commission to enable it to go ahead with the system of harbor improvements now in progress there.

Ottawa, Ont.—The supplementary estimates brought down in the House provide for the sum of \$96,000 for the improvements at Port Stanley and for \$36,000 for similar work at Port Burwell.

Ottawa, Ont.—Special harbor and river votes include one million dollars for Victoria harbor, B.C.; \$750,000 for Port Arthur and Fort William harbors, and one million each for Toronto, St. John and Quebec harbors. The Quebec vote is for the construction of a dry dock.

N.S. Schooner Launched.—The four-masted schooner Letitia Mackay was recently launched at Meteghan. It is the largest vessel of the year to be built in Nova Scotia. She is of 630 tons register. The vessel was built for Adam B. Mackay, of Hamilton, the contract for her building having been taken by Dr. T. H. MacDonald, of Meteghan.

Victoria, B.C.—The City Council have passed a resolution that the Dominion Government be asked to arrange for trackage accommodation, ear-ferry slips and warehouse accommodation on the new breakwater and piers at the Outer Docks, so as to equip the port with facilities to handle all the freight that might be offering at Victoria.

Vancouver, B.C.—Work will be commenced shortly on the construction of a big addition to the Great Northern Railway Co.'s dock at the foot of Campbell Avenue, the extension to cost in the neighborhood of \$50,000. E. B. Ford, chief engineer of the Great Northern at Vancouver, announces that the work will be started as soon as permission to carry it out is obtained from Ottawa.

Panama Canal Passage.—The average time taken by a vessel to pass through the Panama Canal is 11 hours 40 minutes, according to the *Panama Canal Record*. The minimum time recorded is 7 hours 17 minutes, and the maximum is 1 day 8 hours and 10 minutes. The figures, obtained by observing 158 vessels passing through the canal, show that more than half of the ships were in the passage between 9 and 12 hours. Those

requiring more than 12 hours numbered 48.

Vancouver, B.C.—Active work on the construction of the proposed extension to the C. P. R. Co.'s Pier "D," at the foot of Granville Street, will likely commence in about a month, according to a statement given out by F. W. Peters, general superintendent at Vancouver. The pier will be made about 680 feet longer than it is now. The estimated cost of construction is in the neighborhood of \$750,000. Work has already commenced on the preparation of the piles. They are being creosoted in North Vancouver.

Victoria, B.C.—C. C. Worsfold, Dominion Government district engineer, New Westminster, after an inspection of the Ogden Point breakwater has officially taken the structure over on behalf of the Government, and it only remains now for the contractors to erect the lighthouse at the outer end of the big 2,500 foot wall. It is understood that the contract for the 25-foot concrete tower which will house the big beacon will be signed up in the course of a few days, after which work will be started immediately.

Victoria, B.C.—The Board of Trade and the Esquimalt Graving Dock Committee have both been working for some time past to induce the Dominion Government to accede to their proposal to have a dock built here, and the matter is at present under consideration at Ottawa. It has been strongly urged that it would be a great advantage and saving to have the work done by Sir John Jackson, Ltd., as it has its plant already on the ground and that concern's ability to handle the work at a minimum of cost is recognized by all.

Vancouver Harbor Expropriation.—The arbiters appointed in connection with the proceedings taken by the Vancouver harbor board to expropriate the Kitsilano Indian Reserve have handed down their award, naming \$666,200 as the amount of compensation which should be paid by the Harbor Commissioners for the property. The Harbor Board had offered \$500,000 for the Reserve, the Dominion Government set a value of \$1,250,000 upon it upon the advice of their valuator, and some of the realty experts called to testify gave it as their opinion that in a competitive market with large corporations seeking it, the sum of \$2,000,000 might be secured. The reserve comprises seventy acres within the city limits.

Excess Profits Handed Over.—In reckoning excess profits which the shipping companies will have to hand over to the Imperial Government, *Fair Play* takes the amount set aside by thirty companies—namely, 23 pounds 4 shillings per ton gross—and gives a total of sixty-four millions sterling as the contribution from twenty million tons of steam shipping, British owned. "This would indicate," says the paper, "that the total profits of shipping companies exceeded the datum line by about ninety-one and a half million sterling, equal to

ILLINOIS HOBS

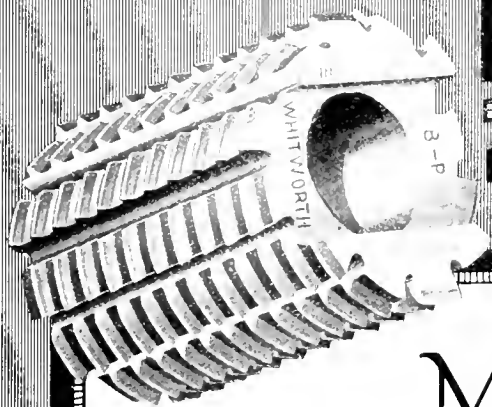

PRODUCE PERFECT THREADS

Multiply your thread milling production and reduce cost by using Illinois Hobs. They are made from best quality high-speed steel, heat-treated by a process that insures long life. The pitch of thread in Illinois Hobs is true to the highest degree of exactness.

When confronted by difficult hobbing problems, you are invited to confer with our engineers, in person or by letter

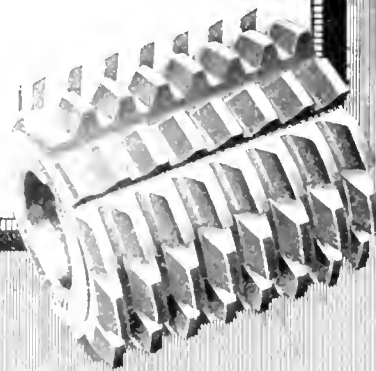

ILLINOIS TOOL WORKS
MANUFACTURERS AND DESIGNERS OF
CUTTERS · HOBS · REAMERS
CHICAGO U.S.A.



BLACK DIAMOND OVENS
 Enameling and Varnishing.
OVENS Heated by
GAS, ELECTRICITY, STEAM or COAL
 Write for New Pamphlet Just Issued
Brantford Oven & Rack Co., Ltd., Brantford, Canada

**We are qualified Tool, Die, Jig,
 Gauge and Fixture Makers.**

WRITE US.

Windsor Machine & Tool Works.
 WINDSOR, ONT.

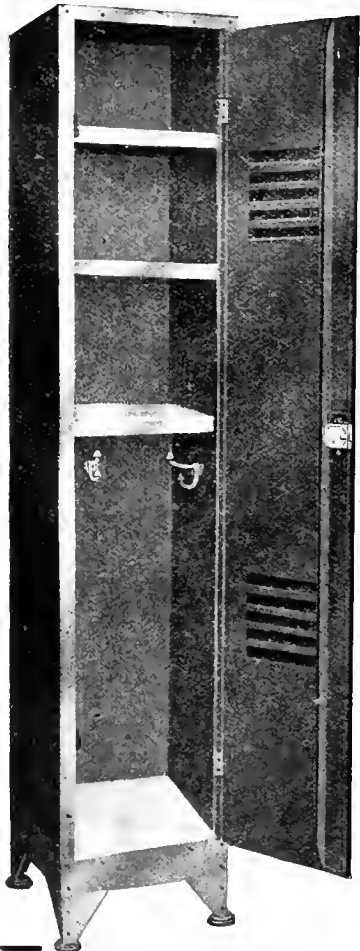

**An Ideal Locker for
 Clothes and Personal
 Tools**

This combination Tool and Clothes Locker will be very useful to the mechanic because it provides ample space for clothes and a safe place for his tools.

Built for life-time service. Supplied in unit or group construction.

We also manufacture **STEEL SHELVING FOR ALL PURPOSES.** Drop a line for full details.

**CANADA WIRE & IRON
 GOODS CO.**

HAMILTON ONTARIO
 Eastern Representative: H. E. O. Bull
 184 Mance St. Montreal, P. Q.

a dividend of nearly fifty per cent. on the pre-war value of two hundred million pounds. Shipowners, however, retain only about seventeen and a half million of this profit, out of which they have to set aside sufficient to cover the extra cost of building and repairs, which is now at a hugely inflated level."

Capt. W. T. Turner was in charge of the transport *Ivernia* when she was torpedoed on New Year's Day in the Mediterranean by a German submarine and sunk with a loss of 120 officers and soldiers and 33 of her own crew. He, it was reported, remained on the bridge until all the troops and his own crew had got away in the lifeboats and rafts before striking out to swim as the vessel went down under his feet. The majority of the crew lost were firemen who were killed when the torpedo exploded inside the *Ivernia* close to the stokehold. Captain Turner had only just joined the *Ivernia*, having left the *Ausonia* in London at short notice and traveled overland from Havre to Marseilles, where the transport was taking on troops and stores. He told the officers on the *Ivernia* how lucky he had been on the eastward voyage of the *Ausonia* from Montreal to London in escaping being torpedoed by a German submarine five miles off Ushant by an hour and a half. He steamed through the wreckage of an 8,000-ton French freighter, which was only six miles ahead of him, he said. Captain Turner is an expert swimmer, and was over three hours in the water when the *Lusitania* was sunk off the southwest coast of Ireland on the afternoon of May 1, 1915.

PERSONAL

W. W. Near, president of the Page-Hersey Iron, Tube & Lead Co., has been appointed a director of the Dominion Bank.

A. L. Smith, C. P. R. superintendent at London, Ont., has been appointed president and general manager of the Algoma and Eastern Railway, with headquarters at Sudbury, Ont.

B. G. Michel, recently engineer for Carleton Place, Ont., has opened offices in the Bank of Toronto Building, Kitchener, Ont., for consulting practice in civil and sanitary engineering.

G. J. Bury, vice-president of the C. P. R., will visit Russia for the purpose of acquiring such geographical and other information as might be of service in dealing with transportation problems. The C. P. R. is handling large quantities of freight via Vancouver and Vladivostok.

TRADE GOSSIP

J. Hall & Sons, Brantford, Ont., recently shipped a cutting-off machine to Russia.

P.W. Ellis Co., Toronto has had its charter extended to cover the manufacture of munitions.

Ottawa, Ont.—Charles H. Vessot, 67 Balsam Avenue, will construct a machine shop. Estimated cost, \$6,000.

Sherbrooke, Que.—A factory for the manufacture of metals will be constructed by N. B. Pritchard, 40 Quebec Street. Estimated cost, \$8,000.

Vancouver, B.C.—Plans are being prepared by the Amalgamated Engineering and Drydock Co. for a shipbuilding plant on Burrard Inlet. Estimated cost, \$5,000,000.

Ottawa, Ont.—T. G. Brigham, 85 Duke Street, is in the market for asphalt-handling machinery, including shafting, sprocket wheels, pulleys, etc.

St. Johns, Que.—Work will soon be started on the construction of a plant for the Dominion Crucible Co. The company will also be in the market for machinery.

Hamilton, Ont.—The Tallman Brass Co. will shortly call tenders for an addition to their plant. Stewart & Wilton, 7 Hughson Street South, are the architects.

The **Murphy Iron Works**, Detroit, Mich., have been awarded a contract by the British Cordite Co. for the 400 h.p. smokeless furnace units to be installed at Nobel, Ont.

St. Catharines, Ont.—The Kinleith Paper Co. plans to build a brick and reinforced concrete addition. Denison & Stephenson, 18 King Street West, Toronto, architects.

G.T.R. Embargo on Freight.—The Grand Trunk Railway have placed an embargo on all cargoes at North Bay, whether carload or less. Traffic way-billed February 4 will be excepted.

Ford, Ont.—Plans are being prepared for a factory for the Canadian Lamp & Stamping Co., to cost \$27,000. Tenders will be received by the architect, G. Jacques & Co., Bong Block, Winnipeg.

Toronto, Ont.—The Dominion Bridge Co., who have the contract for the new department store in Yonge street have placed an order for 13,000 tons of structural steel with the Bethlehem Steel Co.

Montreal, Que.—Canada Stove and Foundry Co. plans to build a concrete, brick and mill construction pipe foundry at St. Laurent. Estimated cost, \$36,000. W. A. Mahoney, 78 Quebec Avenue, Guelph, Ont., architect.

Metals Coating Co., 90 St. James street, Montreal, have secured a new plant at 175 McCord street, into which they will move on May 1. They will manufacture their own apparatus and generally extend the scope of their business.

Ladysmith, B.C.—Construction work has been commenced on additions to the Tye Smelter. Additional land adjoining the smelter property has been secured and approximately \$100,000 will be spent on new buildings, among which will be a converter for the output of copper matte as well as blister copper.

Increase in Monthly Revenue.—A further increase in the Customs revenue is

shown in the monthly statement issued on Jan. 31, by Hon. J. D. Reid. The January revenue was \$12,936,314, an increase of \$2,839,078. For the ten months of the fiscal year the revenue amounts to \$119,549,396, an increase of \$37,730,956.

Dundas, Ont.—Last Monday fire broke out in the Chapman Engine Works, and did damage estimated at \$15,000. This is shared by the Chapman Engine Works and the Mercury Knitting Mills Co., which had its plant in the same building. The Chapman Engine Co. lost considerable of its plant and building.

Montreal Customs Receipts.—Customs receipts broke all January records for this port last month, with total receipts of \$2,916,383. This was a considerable advance on the previous January record of last year, when the customs collections amounted to \$2,265,525. For 1915 the January collections were \$1,541,064, and for 1914 they were \$1,669,455.

Lytle, Smith & Co., engineers' supplies, 422 St. James street, Montreal, has recently been reorganized and will hereafter be known as the Lytle Engineering Co., Ltd. With increased capital, the stock carried will be augmented and facilities provided for speedy delivery on power house and engineers' supplies. Additional space will be acquired by an early removal to 404 St. James street.

B.C. Metal Output.—Official figures of last year's output of British Columbia's mines shows a tremendous increase over all previous years. The returns from all sources are valued at \$42,970,555. This is 45 per cent. better than the showing of the year 1915, and 32.50 per cent. greater than for 1912, which was the banner year previously. Following is a summary of the output of chief metals and coal products: Gold, \$5,389,229; silver, \$2,099,838; lead \$3,186,773; copper, \$18,429,934; zinc \$3,648,599; coal, \$7,093,352; coke \$1,622,850; building materials, \$1,500,000.

Montreal, Que.—The new paper mill of the St. Maurice Pulp and Paper Co. at Three Rivers, Que., has begun operations and the first run on one of the two fifty-ton units on Saturday last proved entirely successful. The capacity of the mill will be one hundred tons, and the second unit of fifty tons will be ready for operation in a few days. A sulphite mill, which has been built in connection with the news print mill has been in operation for several weeks. The St. Maurice Pulp and Paper Co. is a subsidiary of the Union Bag and Paper Co., an American concern.

Gets German Business.—As evidence that trade which was formerly enjoyed by Germany is being assimilated by Canadian firms, especially pertaining to the manufacture and export of articles of various articles of machinery, a Vancouver concern has just completed a large order for a building firm in Durban, South Africa. The Vancouver Engineering Works, of which Geo. Giles is the manager, is the firm which enjoys the distinction of securing this order, which is for a quantity of steel buckets

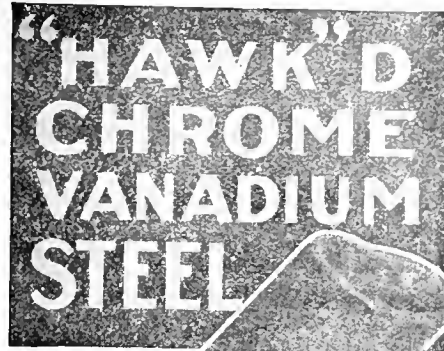

**"HAWK" D
CHROME
VANADIUM
STEEL**

Will
Give You
Exceptional

**Shell Forging
Production**

**WITHOUT AN EQUAL FOR
BOTH FIRST AND
SECOND OPERATION
PUNCHES.**

Comes to you heat-treated and ready for use.

It does not stick to the work.

There are many cases where each punch has turned out over 2,000 shells.

It means more shells, per machine per day.

**STEEL OF EVERY
DESCRIPTION.**

**Hawkrige Brothers
Company**

303 Congress St., BOSTON, MASS.
U. S. A.

THE IRON WORKS LIMITED
Successors to

Owen Sound Iron Works
Owen Sound, Ont.
Engineers
Boiler-makers
Founders
Machinists

Tank Work
Smoke Stacks,
Grey Iron and
Brass Castings,
Special
Machinery
Made to
Order

I BELIEVE

*In Safety First and always.
In providing for the Health of my Fellow Workmen.
In Light and Air and sanitary Working Conditions.
In clean, fresh drinking water for everybody.
In the Safety, Economy and Man-betterment.*

PURO SANITARY DRINKING FOUNTAIN

(MADE IN CANADA)

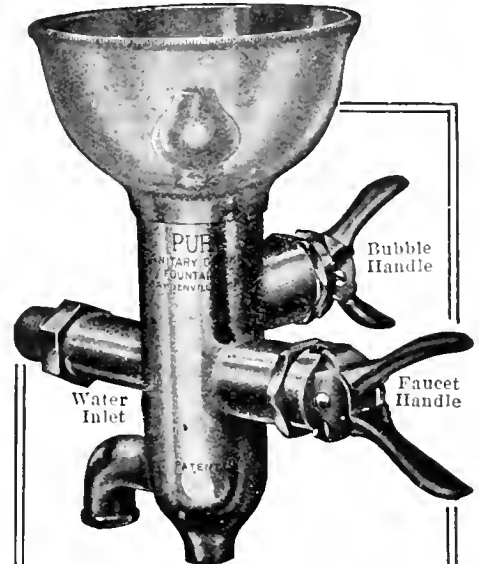

The loss of a man through impure drinking water is a crime that "the front office" must bear.

An ugly statement, isn't it? But true, absolutely.

When a man comes to work in your factory he puts his health in your keeping.

Are you willing to take chances on such a trust?

Impure drinking conditions are responsible for more tragedies than any machine ever built.

Apply the "Safety First" Principles to your water supply; don't deny your men a clean, fresh drink of water.

Conserve their health and they will improve your profits; make yourself as worthy of the name of "employer."

Install the Gold Medal winner Puro in your plant, office and shop alike.

The only Sanitary Drinking Fountain that is safe, sanitary, simple, automatic in control and easily attached.

Let us tell you just what it will cost you to

"PURO - FY"

YOUR WATER SUPPLY

Puro Sanitary Drinking Fountain Company
147 University Ave., Toronto, Canada

"Barnes-Made" SPRINGS

are unusual in service and wear

They are the result of sixty years' experience, unsurpassed equipment and highly skilled workmanship.

A trial will convince you that "Barnes-Made" Springs are the best buy.

Established 1857

THE WAHAGE BARNES COMPANY
218 South St., Bristol, Ct., U.S.A.

Makers of "Barnes-made" Products
Springs, Screws, Machine Products, Cold Rolled Steel and Wire



PATENT ATTORNEYS

BABCOCK & SONS

ESTAB. 1877

PATENTS—TRADE MARK—DESIGNS
 IN ALL COUNTRIES

 Book "Patent Protection"—free. Master
 of Patent Laws. Formerly Patent Office
 Examiner.

 99 St. James St., - Montreal, Que.
 Branches: Ottawa, Washington.

RESEARCH BUREAU

 REPORTS BY EXPERTS ON SCIENTIFIC, TECHNICAL
 AND INDUSTRIAL DEVELOPMENT.

SPECIAL RESEARCHES ARRANGED.

PATENTS, TRADE MARKS, ETC.

HANBURY A. BUDDEN

CABLE ADDRESS

712 DRUMMOND BLDG., MONTREAL

"BREVET"

PATENTS

Fetherstonhaugh & Co.
 Patent Solicitors, Head Office,
 Royal Bank Bldg., Toronto,
 Ottawa Office, 5 Elgin St.
 Send for our Plain Practical
 Pointers. Copy of National
 Progress, in which our patents
 are advertised, mailed free.

PATENTS PROMPTLY SECURED

 In all countries. Ask for our Investor's
 Adviser, which will be sent free.

MARION & MARION, 364 University St.

 Merchants Bank Building, corner
 St. Catherine St., MONTREAL, Phone Up. 6474
 and Washington, D.C., U.S.A.

Special Machinery

**Gauges, Fixtures, Dies
 and Precision Tools.**

—————

We have the most modern
 equipment to handle any
 class of work.

—————

 Canadian Distributors for the
Albany Patent Rotary Pump

Albany Pump Co.

16 Pearl St., Toronto, Ont.

Phone Ad. 2511 A. W. Bennet, Manager

to be shipped to the South African Cement Co. The contract is worth in the neighborhood of \$5,000, and it is understood the firm secured the order in open competition.

Owen Sound, Ont.—Important additions will be made to the plant of the Northern Nut, Bolt & Screw Co., including the erection of a new boiler house, another wire annealing oven and a wire-cleaning house. The latter work will leave more room in the present building for wire machinery and frames. A new 50-h.p. motor will be installed to operate a nut-drawing plant. Four additional machines, an additional header and an additional bolt machine will be installed. A new hot galvanizing plant and an addition to the electrical galvanizing plant will be built. A keg and box mill will also be erected.

Vancouver, B.C.—The establishment of new industries in Vancouver, and the locating of another in the near future, has been announced by Industrial Commissioner Davison. One of the new industries, the Maritime Motor Co., has the exclusive rights for the manufacture of the only type of gasoline driven mining and logging locomotive built in Canada. This locomotive can be built for any track. The first locomotive made in Vancouver will be shipped in a few days to a point up coast. Orders for five more locomotives have also been placed with the new firm. The Dominion Safe Works will establish in Vancouver in the near future, a site having been secured by it on the industrial island.

Record Freight Rates.—The highest freight rates in history have developed in the past few weeks, with the result that it now costs \$75 to ship a ton of copper to Mediterranean ports, as compared with a \$4 rate in effect prior to the outbreak of the European war. Current agitation concerning renewed submarine activity has likewise added its mite to an already heavily burdened situation, with war risks quoted as high as 10 per cent. to ports along the Mediterranean. To French ports the steamship companies have raised their freight rates to \$45 a ton, against from \$2.50 to \$3 in normal times. To other ports bordering on or near the war zone rates have been advanced commensurately with those noted above.

WOODWORKING

Preston, Ont.—The Preston Car & Coach Co., will rebuild their plant which was recently damaged by fire.

Vancouver, B.C.—The saw mill at Skidegate, on Queen Charlotte Island, has been bought by the Weir Machinery Co. It has not been in operation for some time, but will be immediately opened up.

Sydney, N.S.—McCallum's carriage shop, a large wooden building on the corner of Townsend Street and the Esplanade, was destroyed by fire on January 21. The loss is estimated at \$14,000, about half covered by insurance.

RAILWAYS—BRIDGES

Toronto, Ont.—An application will be made to the Parliament of Canada, at the present session thereof, for an Act to incorporate a railway company under the name of "The Kenora and English Railway Co."

Toronto, Ont.—An announcement was made recently by Sir William Mackenzie that the C.N.R. was about to commence the construction of a railway from Toronto to the Niagara frontier. The work will involve an aggregate expenditure of \$7,000,000 and will result in a closer commercial compact between Toronto, Hamilton, St. Catharines and the United States.

BUILDINGS

Montreal, Que.—A new moving picture theatre is to be erected on St. Catherine Street West, opposite Phillips Square. The new theatre will be operated by the Holman Theatres, Ltd. The entire building will be fireproof, being constructed of concrete and steel, with a steel roof.

REFRIGERATION

Chatham, Ont.—The City Council has closed a deal with the Libby packing house of Chicago to open a branch here, the city giving land for a \$100,000 plant.

CATALOGUES

The Atlas Crucible Steel Co., of Dunkirk, N.Y., manufacturers of fine tool steels, including L-XX high speed steel have issued a new catalogue of their various products. This catalogue deals comprehensively with the uses of the various steels and their heat treatments.

Firebrick Blocks.—A new bulletin dealing with the "Gates" firebrick blocks has been issued by John W. Gates, Montreal. The application of these firebrick blocks is shown by means of a number of illustrations accompanied by descriptive matter. The bulletin describes all types of blocks now being used largely in place of ordinary firebrick.

Steam Traps.—Bulletin No. 5 describes an interesting line of steam traps, made by the Geo. W. Cole Co., Toronto. The principal features of the "Cole" direct return trap are dealt with while the essential particulars and prices are given covering the various sizes. The bulletin is illustrated and includes a diagram showing a double trap installation with a table of fuel losses.

BOOK REVIEWS

The Story of the Canadian Pacific Railway by Keith Morris, 154 pages 7 in. x 4½ in., 10 illustrations. Published by William Stevens Ltd., London, England. This is a new book telling the story of the C.P.R. from the time of its inception to the present day. It is a

tale of a great achievement beginning at a time practically 60 years ago, when the West was a trackless waste. The idea of building a transcontinental was first considered as far back as 1857 when an Imperial Commission was established by the British Government to enquire into the suitability of the then colony of Canada for settlement and the advisability of constructing a transcontinental railway through British Territory from the Atlantic to the Pacific Ocean. The opening chapter, "Pathfinders," deals with the physical condition of the country and the men who explored and surveyed the right of way, describing vividly the difficulties which had to be surmounted. The second chapter "Pathmakers" deals briefly, and in a popular style with the construction of the road, introducing George Stephens, Donald Smith, and other well known personages who were responsible for building the railway. The next chapter "Craigellachie" deals more particularly with the men of the time, who were associated in the great enterprise. The political and national advantages of connecting British Columbia with Eastern Canada, or, as it is called "The Saving of British Columbia," are outlined in chapter four, while in chapter five "The Highway to Asia" the value of a transcontinental road is further emphasized. The next chapter, "Superstructure," reveals the economic advantages opened up by the C.P.R., while in the chapter "The Making of a Nation" the development of the country is described. The book concludes with an appendix on Canadian Pacific finance, and shows the wonderful progress which the C.P.R. has made, particularly during recent years. This is an exceedingly interesting book, relating in a popular style the development of that great enterprise which culminated in one of, if not, the most important transportation company in the world.

A PRICE PYROMETER makes it certain

Get a Record of Working Temperatures

Uncertainty is a time and effort waster—to be sure at a glance means efficiency. There is no "doubt," when you have a Price Pyrometer.

See that there is a Price Indicating Instrument within sight of every furnace in your heat-treating department. And have a Price Recording Pyrometer in your office to get a record of working temperature.

Let us send you our Catalogue and full partic-

ulars — How you can make it certain.

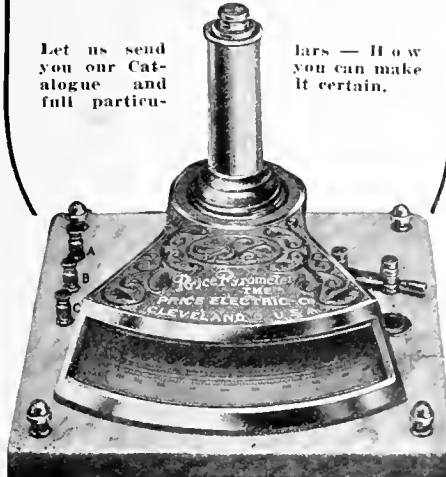

THE PRICE ELECTRIC CO.
12368 Euclid Avenue, CLEVELAND, OHIO

METAL STAMPINGS

We are manufacturers of stamped parts for other manufacturers.

We do any kind of sheet metal stamping that you require. Our improved presses and plating plant enable us to produce the finest quality of work in a surprisingly short time.

We can finish steel stamping in Nickel, Brass or Copper.

Send us a sample order.

W. H. BANFIELD & SONS
372 Pape Avenue, Toronto, Can.

MORTON MANUFACTURING CO.
PORTABLE PLANERS
DRAW CUT SHAPERS
SPECIAL DRAW CUT R.R. SHAPERS
FINISHED MACHINE KEYS
STATIONARY & PORTABLE KEY WAY CUTTERS
SPECIAL LOCOMOTIVE CYLINDER PLANERS
OFFICE AND WORKS: MUSKEGON HEIGHTS USA

WEBBER BROS. MACHINE COMPANY

Gear Blanks, Shell Punches, Boring Bars, Special Tools.

Machinery of all kinds built to your specifications.

Better Work. Reasonable Prices.
848 Dupont St., Toronto.
Phone Hill. 2746

MAKE YOUR DOLLARS

FIGHT

AT THE FRONT.

BUY

DOMINION OF CANADA

THREE-YEAR

WAR SAVINGS CERTIFICATES

\$ 25.00 FOR \$21.50
50.00 " 43.00
100.00 " 86.00

INDIVIDUAL PURCHASES LIMITED TO \$1500.

FOR FULL PARTICULARS APPLY AT ANY BANK OR ANY MONEY ORDER POST OFFICE

JAN. 9, 1917

FINANCE DEPARTMENT
OTTAWA

Classified Advertising Section

Rates (payable in advance): Two cents per word first insertion; one cent per word subsequent insertions. Count five words when box number is required. Each figure counts as one word. Minimum order \$1.00. Display rates on application.

FOR SALE

MACHINE SHOP FOR SALE — MEDIUM size. Modern tools, lathes, Universal milling machine, Universal grinder. Equipped for good work. Box 267, Canadian Machinery. c10m

BOILER FOR SALE—HORIZONTAL RETURN tubular boiler, 66" diam., 15 feet long, 58 4" tubes. For immediate delivery. Steel Co. of Canada, Ltd., Montreal. (5)

GAP LATHE, 28 x 42 x 16 FT. BED, FOR sale, cheap; also emery wheel stand, power hack saw. Guarantee Motor Co., Hamilton, Ont. (1f)

FOR SALE — 1 NEW SHORE SCLEROSCOPE, complete with all regular equipment. Pease Foundry Company, Limited, Brampton, Ont. Jet. 4341. c6m

FOR SALE — ONE WEST TIRE-SETTER, hydraulic shell banding machine, complete, for 3" Russian shrapnel shells. Consolidated Car-Heating Co., 413 No. Pearl St., Albany, N.Y. (6)

FOR SALE — NO. 50 GARDNER SWING grinder. Has 24" diameter ring wheel and was purchased for grinding base of 18-pdr. shells, but never used. Canadian Blower & Forge Co., Kitchener, Ont.

1-2-SPINDLE SHAPER, WOOD TOP, JOHN Ballantyne, Preston, make, used two months. 1 Dynamo, 45 lights, Toronto and Hamilton Electric Co. make. Used five months. Good as new. Box 195, Jordan, Ont. (R.T.F.)

25 CYCLE MOTORS IN STOCK TORONTO. Sizes in horse-power tens, fifteens, twenties, thirties, forties, fifties, seventy-five and one hundred fifty, standard voltage, slow speed. Boyd-McBarney, 220 King St. West, Main, 2330. c7m

SHRAPNEL SOCKET AND ADAPTER machinery, turret lathes, boring machines, cutting-off machines and thread millers tooled for operation. Globe Electric Machine Co., Hamilton. (1f)

FOR SALE — 1 NO. 3208 TATE-JONES furnace, also 1 nose annealing furnace, 14 holes, for 2" Russian shrapnel. Consolidated Car-Heating Co., 413 N. Pearl St., Albany, N.Y. (4)

FOR SALE—5' FULL UNIVERSAL RADIAL drill, with eight changes of speed. Scott Bros. make. Practically as good as new. Immediate shipment. Canadian Linderman, Ltd., Woodstock, Ont. (5)

6-30 H.P. PRACTICALLY NEW, LATEST type Canadian General Electric Company's 30 H.P., 60 cycle, 550 volts, 3 phase, 900 R.P.M. induction motors, with starting compensators and adjustable sliding base, pulley 14", diameter 8" face. Price \$500 each f.o.b. Sarnia, Ont. 1-20 H.P., same as above, pulley 11" diameter, 10" face. Price \$290 f.o.b. Sarnia, Ont. H. Mueller Mfg. Co., Sarnia, Ont. (3)

THE FOLLOWING SHELL MACHINERY is available for immediate shipment:
1-5" Jenckes Copper Band Lathe.
1-5" Jenckes Rough Wavy Groove Lathe.
1-6" Jenckes Finish Wavy Groove Lathe for Mark XVI shell. Can be changed for Mark III, if desired.
1 Potter & Johnston Automatic Lathe.
1 4.5 Brown-Boggs Marking Machine.
Box 261 Canadian Machinery. (7)

WANTED

SHOP IN WINDSOR, ONT., EQUIPPED partially or wholly for special machine, tool and repair work. Send full details. F. G. Hubbard, Box 832, Bridgeport, Conn. c9m

WANTED — MOTORS 10 TO 50 HORSE-power, 25 cycle, 550 volts, alternating current. Quote price and delivery. Canadian Fairbanks-Morse Co., 1379 Bloor Street, Toronto. c11m

REPAIRING

ALL KINDS OF MACHINERY REPAIRED, rebuilt and installed. W. H. Sunbling Machinery Co., 7 St. Mary St., Toronto, Ont.

SITUATIONS WANTED

TOOL MAKER, ACCURATE, GOOD draughtsman, desires responsible position. Box 254, Canadian Machinery. (4)

SUPERINTENDENT, MECHANICAL, WITH proven ability, experienced in manufacture of small arm ammunition, 18-pr. shrapnel and high explosive shells, tool room and general machine shop practice; 20 years responsible position in Government arsenals, desires similar position; now disengaged. Box 262, Canadian Machinery, Toronto. (3)

SUPERINTENDENT OR WORKS MAN- ager desires position with first-class concern. Specialist on automatic small die press work. Expert in handling men. Twenty years' experience as manager in cartridge factories. Capable of taking complete charge of installation. Apply Box 263, Canadian Machinery. (7)

SUPERINTENDENT WITH TWENTY- nine years' broad mechanical experience in different lines of manufacturing desires permanent connection with well known con-

cern in need of a broad gauge man of unlimited energy and enthusiasm; long proven executive ability, strong personality, unquestioned integrity, strictly temperance, positive aggressive character with good judgment; highest references. Answer Box 260, Canadian Machinery. (2)

SITUATIONS VACANT

DRAFTSMAN WANTED ON MACHINE shop equipment—jigs, tools, etc. State experience and salary expected. Box 265 Canadian Machinery. (9)

CANADIAN REPRESENTATIVE FOR American firms building special machinery, tools and gauges. Liberal commission to a business-getter. Box 266, Canadian Machinery. c9m

GENERAL FOREMAN AND CHARGE hands for machining operations on 18-pounder high explosive shells. None but experienced men need apply. P.O. Box 1164, Winnipeg, Man. (5)

WANTED — DRAFTSMAN CAPABLE OF designing small tools, jigs, etc. Steady employment. Please state experience and wage expected. Butterfield & Co., Inc., Rock Island, Que. (4)

WANTED SUPERINTENDENT CAPABLE of taking charge of 4.5 shell manufacturing plant. Must be thoroughly familiar with this type of shell and capable of producing results. Will pay good salary and bonus to the right man. State experience and full particulars in first letter. Apply Medicine Hat Pump & Brass Mfg. Co., Ltd., Medicine Hat, Alberta. c6m

SPECIAL MACHINERY

FUSE EQUIPMENT — SPECIAL MACHINERY for manufacturing fuses, including rethreading machines for base plugs, with tools. "Harris," Box 1008, Bridgeport, Conn. c9m

FOR ALL KINDS OF GAUGES, JIGS AND special machines, also machine tools, lathes, milling machines, etc. Write H. P. Eilers, 580 St. Nicholas Ave., New York City. (5)

FOR SALE Shipment from Stock

3—"Lees Bradner"
Thread Millers
arranged for mill-
ing 2" 14 thread in
Nose of 4.5 Mark
VII H.E. Shells.

*For complete particu-
lars—write*

Williams & Wilson
Limited
320 St. James St., Montreal, P.Q.

Wanted!

SECOND-hand Foundry equipment wanted for a foundry handling light castings. Complete equipment needed — must be in good condition.

BOX 264

Canadian Machinery

CANADIAN MACHINERY

AND MANUFACTURING NEWS

A weekly newspaper devoted to the machinery and manufacturing interests.

Vol. XVII.

TORONTO, FEBRUARY 15, 1917

No. 7

EDITORIAL CONTENTS

Canadian Government Small Arms Ammunition Factory	123-125
General	125-126
Friction Clutches—II. Detecting Faults in Castings.	
Editorial Correspondence	127-128
Shell Base Interior Finishing Bar. Tensile Strength of Round Steel Rods. Obtain- ing Draft Without High Chimneys. Adjustable Supporting Post.	
General	128
Examples of Form Grinding. Heroult Furnace Installations.	
Safe Practice at Blast Furnaces—III	129-134
General	134
Abrasives, Asbestos and Brick. Special Tribunal for Business Men.	
Spokes in Industry's Wheel	135-136
James Alfred Stairs.	
General	136
Compressed Air in Railroad Shops.	
Progress in New Equipment	137-138
Rapid Production Shell Lathe. Five-Spindle Horizontal Rail Drilling Machine Large Electric Motor. Feeding Fixture for Die-Forming Machine. Protection-Edge Laminated Belting. Machinists' Screw Driver.	
Editorial	139
The Pig Iron Situation. Future Aspects of Skilled Labor.	
Selected Market Quotations	140-141
The General Market Condition and Tendency	141-143
Summary. Montreal Letter. Toronto Letter.	
Industrial and Construction News	144

THE MACLEAN PUBLISHING COMPANY, LIMITED

JOHN BAYNE MACLEAN, Pres. H. T. HUNTER, Vice-pres. H. V. TYRRELL, Gen. Man.

Publishers of Hardware and Metal, The Financial Post, MacLean's Magazine, Farmer's Magazine, Canadian Grocer, Dry Goods Review, Men's Wear Review, Printer and Publisher, Bookseller and Stationer, Canadian Machinery and Manufacturing News, The Power House, The Sanitary Engineer, Canadian Foundryman, Marine Engineering of Canada.

Cable Address: Macpubco, Toronto; Atabek, London, Eng.

ESTABLISHED 1887.

CANADIAN MACHINERY

AND MANUFACTURING NEWS

PETER BAIN, M.E., Editor. R. G. NEWTON, Manager.
Associate Editors: A. G. WEBSTER, J. M. WILSON, J. H. RODGERS.

CHIEF OFFICES:

CANADA—Montreal, 701-702 Eastern Townships Building; Toronto, 143-153 University Ave., Telephone Main 7324; Winnipeg, 22 Royal Bank Building, Telephone Garry 2343.

GREAT BRITAIN—LONDON, The MacLean Company of Great Britain Limited, 88 Fleet Street, E.C., E. J. Dodd, Director, Telephone Central 12900. Cable Address: Atabek, London, England.

UNITED STATES—New York, R. B. Ingestis, 115 Broadway, N.Y., Telephone Rector 8971; Boston, C. L. Miron, Room 733, Old South Building, Telephone Main 1291; A. H. Byrne, 1104 5-6 7 Fort Dearborn Bldg., 105 W. Monroe St., Chicago, Telephone Randolph 3231.

SUBSCRIPTION PRICE—Canada, Great Britain, South Africa and the West Indies, \$3.00 a year; United States, \$3.50 a year; other countries, \$4.00 a year; Single C. plus 15 cents. Invariably in advance.

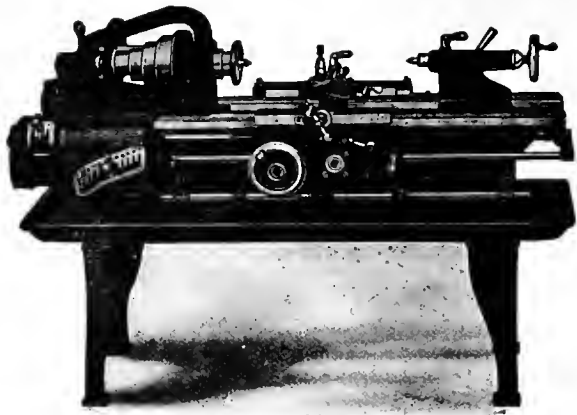

The "HENDEY" Lathe

The Service

Capacity and Convenience

of a Hendey Lathe will prove of vital importance to your tool room.

The "Hendey" is accurate in the highest degree and suited for the efficient use of watch tool chucks, stop chucks, relieving attachments, etc.

It has the best spindle construction in its taper journals, with annular bearings and automatic oiling rings, which make for accuracy of alignment.

It has automatic stop for carriage working in either direction. Has reverse for carriage, controlled from apron.

Wide range of threads and feeds through mounted gearing, with ability to make gear changes for additional threads and feeds without limit.

A card will get you full particulars. Why not mail it now?

THE HENDEY MACHINE COMPANY TORRINGTON, CONN., U.S.A.

Canadian Agents: A. R. Williams Machinery Co., Toronto, Ont.; A. R. Williams Machinery Co., 260 Princess St., Winnipeg; A. R. Williams Machinery Co., Vancouver; A. R. Williams Machinery Co., St. John, N.B.; Williams & Wilson, Montreal.

INDEX TO ADVERTISERS

A	Dale-Brewster Mch. Co. 66	K	Racine Tool & Machine Co. 55
Aeroplane Products, Ltd. 169	Deloro Smelting & Refining Co. 6	Kasenit, Ltd. 30	Reed-Prentice Co. 29
Albany Pump Co. 62	Drury, H. A., Co. 7	Kennedy, Wm., & Sons 14	Reliance Machine Co. 24
Anderson, H. N. 82	De Moor Mach. Co. 88	King, Ltd., Warden 15	Rhodes Mfg. Co. 28
Armstrong Bros. Tool Co. 100	Dept. of Finance 59, 96 and 113	L	Ridout & Maybee 28
Armstrong, Whitworth, of Canada 10	Diamond Saw & Stpg. Wks. 78	L'Air Liquide Society 105	Riverside Mach. Co. 68
Atkins & Co., Wm. 13	Dominion Mch. Co. 22 and 61	Lancashire Dynamo Co. 30	Rockwell Co., W. S. 25
Atlas Crucible Steel Co. 10	Dominion Steel Fdy. Co. 98	Landis Machine Co. 99	Roclofson Mach. & Tool Co. 25
Atlas Press Co. 99	E	M	Roper, C. F., Co. 84
B	Eastern Machine Screw Corp. 76	MacKinnon, Holmes & Co. 60	S
B.A.B. Model Mfg. Co. 80	Elmes Eng. Works, Charles P. 76	Main Belting Co. 84	Scott Mach. Co., G. H. 26
Babcock & Sons 60	Eric Foundry Co. 107	Manufacturers Equipment Co. 90	Shuster Co., F. B. 109
Baird Machine Co. 109	F	Marsh & Henthorn 105	Simmons Mach. Co. 92
Banfield, E. J. 14	Fairley-Davidson Steel Co. 8	Mathews, Jas. H., & Co. 99	Skinner Chuck Co. 97
Banfield & Sons, W. H. 61	Fetherstonhaugh & Co. 69	McCabe, J. J. 32	Slocum, Avram & Slocum 107
Barnes, Wallace, Co. 63	Fitzgerald, W. H. J. 67	McKay Co., James 32	Small-General Co., Inc. 26
Baxter & Co., J. H. 15	Foss & Hill Machy. Co. 77	McDonnell Co., R., Inside back cover	Smart-Turner Mach. Co., Ltd. 59
Bertram, John, & Sons Co. 1	G	McLaren Belting Co., J. C. 98	Standard Alloys Steel Co. 8
Blake Pump & Condenser Co. 77	Foundry & Mach. Co. Inside back cover	Mechanical Engineering Co. 74	Starrett Co., L. S. 75
Blake & Johnson Co., The 92	Gawlner Machine Co. 93	Metals Coating Co. 15	Steel Co. of Canada 38
Blount Co., J. G. 28	Garlock-Walker Machy. Co. 22	Metalwood Mfg. Co. 81	Steeptoe Co., John 81
Brantford Oven & Rack Co. 59	Garvin Machine Co. 26	Milhollan Mach. Co. 73	Stocker-Rumley-Wachs Co. 49
Bridgeford Mach. Tool Works 5	Geometric Tool Co. 57	Modern Tool Co. 88	Stow Mfg. Co. 75
Bristol Co. 97	Gilbert & Barker Mfg. Co. 72	Montreal General Tool Co. 22	Sturtevant Co. of Can., Ltd., E. F. 89
Brownell Machy. Co. 65 and 67	Gibb Instrument Co. 73	Montreal Machy. & Supplies, Ltd. 32	Swedish Gage Co. 9
Brown's Copper & Brass Rolling Mills, Ltd. 71	Grant Gear Works, Int. 98	Morse Twist Drill Co. 103	Swedish Steel & Importing Co. 9
Budden, Handbury A. 60	Grant Mfg. & Machine Co. 103	Morton Mfg. Co. 61	Symington Co., T. H. 10
C	H	Murphy Machine & Tool Co. 90	T
Canada Machinery Corp. Outside back cover	Hamilton Mach. Tool Co. 33	N	Tabor Mfg. Co. 160
Canada Metal Co. 84	Hamilton Motor Works 99	National Machine Tool Co. 100	Taylor Instrument Co. 72
Can. S.K.P. Co. 4	Hamilton Gear & Machine Co. Front cover	New Britain Machine Co. 63	T. C. M. Mfg. Co. 86
Canada Sales Co. 79	Hanna & Co., M. A. 9	New York Machy. Exchange 68	Thwing Instrument Co. 72
Can. Bond Hanger & Coupling Co. 91	Hankridge Brothers Co. 63	Nicholson File Co. 81	Toronto Iron Works 87
Can. Desmond-Stephan Mfg. Co. 63	Hendley Machine Co. 116	Niles-Bement-Pond, Inside front cover	Toronto Testing Laboratory 109
Can. Economic Lubricant Co. 53	Hepburn, John T., Ltd. 17	Noble & Westbrook 97	Toronto Type Foundry 16
Can. Fairbanks-Morse Co. 34	High Speed Hammer Co. 103	Northern Crane Works 98	U
Can. Hoskins, Ltd. 92	Himoff Mach. Co. 98	Novon, A. O. 22	United States Electrical Tool Co. 51
Can. Ingersoll-Rand 95	Hoyt Metal Co. 100	Novon Company 22	V
Can. Inspectoog & Testing Laboratories, Ltd. 97	Holz, Herman A. 73	Nova Scotia Steel & Coal. 12	Vanadium-Alloy Steel Co. 12
Can. Matthews Gravity Co. 59	Hull Iron & Steel Foundries 76	O	Victor Tool Co. 68
Can. Metal Products Co. 99	Hunter Saw & Mach. Co. 61	Oliver Machinery Co. 27	W
Can. B. K. Morton Co. 11	Hurlbut-Rogers Machy. Co. 99	Ontario Specialties, Limited 100	Walcott Lathe Co. 25
Can. Morehead Mfg. Co. 111	Hyle Engineering Works 91	Oven Equipment & Mfg. Co. 153	Warner & Swasey Co. 25
Can. Steel Foundries, Ltd. 7	Hungerford Brass & Copper Co. 73	P	Wells Bros. of Canada, Ltd. 31
Carlyle, Johnson Mach. Co. 83	I	Parmenter & Bullock Co. 109	Whiting Foundry Equipment Co. 111
Carter Welding Co. 58 and 87	Ideal Tool & Mfg. Co. 89	Peck, Stow & Wilcox 96	Whitman Mfg. Co. 28
Chapman Double Ball Bearing Co. 85	Independent Pneumatic Tool Co. 91	Peerless Mach. Co. 95	Wickes Brothers 109
Cincinnati Pulley Mach. Co. 74	Iron Works, The 58	Perin, Wm. R. 81	Williams, J. H., & Co. 113
Cincinnati Iron & Steel Co. 74	J	Petrie, H. W. 65	Williams Machy. Co., A. R. 7
Cleveland Pneumatic Tool Co. 107	Jacobs Mfg. Co. 91	Positive Clutch & Pulley Works 98	Williams & Wilson 88
Clippert Belt Lacer Co. 82	Jenckes Machine Co. 9	Pratt & Whitney Co. Inside front cover	Windsor Mach. Co. 89
Cook, Ass. S., Co. 99	Jersey City Machine Co. 99	Price Electric Co. 61	Winnipeg Gear & Engr. Co. 57
Corbet Fdry. & Mach. Co. 25	Jones & Glasco 82	Pritchard Co., C. W. 66	Z
Cullen Mch. Co., C. E. 67	Johnson Mach. Co., Carlyle 83	Pringle, R. E. T. 31	Zenith Coal & Steel Products 94
Cushman Chuck Co. 97	D	Puro Sanitary Drinking Fountain Co. 62	Zin-Ho Mfg. Co. 94
Davis-Bourneville Co. 87	Davis, W. F., Machine Tool Co. 69		

Canadian Government Small Arms Ammunition Factory

Contributed

Whatever ultimate effect the war may have on the preparedness of nations, the fact has been well recognized by this country that ammunition occupies a place of equal importance with men and guns, and evidence to this effect was given some time ago when the Government established the plant referred to, at a suitable inland point. Developments in methods and equipment have been frequent since August, 1914, and, together with the great number of operators on munition work, insure the future value of the new plant as a national asset.

THE small arms ammunition factory now in process of erection, is designed and will be equipped to manufacture 300,000 British .303 rifle cartridges in ten hours. It consists of a large number of separate buildings housing a wide variety of complicated manufacturing equipment.

Plant Layout

In the general plan of buildings layout, the routing of material has been carefully studied from a purely manufacturing standpoint to insure a minimum of handling. The type, plan, and general dimensions of buildings have been considered in their relation to the manufacturing equipment. Several important details which influenced the designs were: The stresses set up by the power transmission; the determination of the amount and location of glazed window areas in order to provide the most desirable lighting and ventilating conditions with the maximum economy of lighting, heating, and ventilating; and the peculiar hazards involved in buildings where explosives are stored and handled. The manufacturing equipment has involved the purchase and installation of over 500 pieces of machinery, which are in the main of a highly special nature, complicated in design and varied in type and function.

The arsenal buildings are divided into four groups on a one-hundred-acre plot. Fourteen structures comprising the main manufacturing group are located in the north-west corner of the plot. These buildings, lying parallel to each other, are connected at their east ends by a passageway, which gives access to all. This group includes a two-storey brick office 40 x 90 ft.; brass foundry, 70 x 80 ft.; rolling mill, 70 x 200 ft.; case plant, 80 x 300 ft.; bullet plant, 60 x 300 ft.; machine shop and tool room, 42 x 300 ft.; case and bullet inspection building, 50 x 165 ft.; carpenter shop, 42 x 150 ft.; gas plant, 42 x 78 ft.; boiler house, 42 x 55 ft.; storehouse, 50 x 100 ft.; and a transformer station.

With the exception of the office, store-

house, case and bullet inspection building, all of the foregoing are of steel frame construction. The office building has hollow tile walls, with tapestry brick facing, wood floor joists and studding, and is plastered throughout. Here superintendent Lieut.-Col. S. S. Weatherbee, with his assistants, clerks, draftsmen, etc., have their offices. The chemical and mechanical laboratories, testing rooms, first aid ward, library and lecture room, also a two-storey fire-proof vault, for books, records, and drawings, find a location in the office building. The storehouse, and the case and bullet inspection building are of one storey, with hollow tile walls, wood posts and roof framing and steel sash. The inspection building has a wood floor on a tar Rok base.

The main manufacturing buildings are one-storey steel frame, with hollow tile walls, steel sash, and concrete roofs.

with the exception of the space around the annealing furnaces in the latter, where cast iron plates set in concrete are used because of the handling of trucks of hot metal in these sections. In the gas plant and in all buildings where wet conditions of manufacturing are encountered, the floors are of concrete pitched to drains. All other floors are of hemlock underflooring, with maple wearing surface on a tar Rok base.

The steel sash used in the side walls are continuous between columns, and extend from the concrete sill at the top of the five-foot base wall to the eaves purlin. Monitor sash are also continuous between truss posts, and are about five feet high. All ventilating units in these sash are operated by a straight push operator in runs of approximately 150 feet between operating stations. All sash are glazed with factory ribbed glass, with ribbed wire glass in the vents. The roofing for all buildings is five-ply Barrett Specification.

Loading and Magazine Group

The nine buildings of the loading group are about one thousand feet east of the main manufacturing buildings. They are all small, ranging in size from 16 x 26 feet, to 29 x 99 feet, and are connected by a passageway through which all materials may be handled unimpeded by weather conditions. They have tile walls, steel sash, mastic asphalt or special flashproof composition floors on a concrete base, and roofs of concrete or light wood framing. Toilet rooms and coat rooms are provided opening off the passageway, and are of similar construction to the other buildings, are separated from the main ground because of the dangerous operation carried on.

The eight buildings constituting the magazine group are situated about six hundred feet south of the loading buildings. They are of tile construction, with light wood roofs and non-gritty asphalt floors. Earth embankments eight feet in height surround each



CAR DEPARTMENT ACTIVITIES, C.P.E. ANGUS SHOPS, MONTREAL.

Only two designs have been used in the steel frames—one a forty-foot truss, the other a fifty-foot truss on steel columns spaced nineteen feet on centres. The steel contract was awarded on a pound price basis, the steel work being then detailed so that material which Canadian yards had in stock could be used as far as possible. The use of trusses of the same design in several buildings simplified the detailing and shopwork, and resulted in remarkably quick shipment considering present market conditions. The boiler house and the rolling mill are floored with paving brick,

magazine building. This type of protection is also used around the loading buildings where quantities of explosives are in use or in storage.

Rifle Range

The fourth group includes a rifle range and an ordnance inspection and stores building, where final inspection is given the cartridges, and where they are packed and stored for shipment. The rifle range, housing both a 600-yard and a 60-yard range, is a concrete structure built below ground. The 600-yard range is a 6 x 7 foot reinforced concrete tunnel, curved to follow the trajectory of a bullet and having pockets at the side for target setting every hundred yards, and a target house at the east end. The 60-yard range is 2½ feet wide by 7 feet high, of similar construction to the 600-yard range, and having two side pockets and a target house. The firing house is a reinforced concrete structure about 25 feet square, the floor of which is seven feet below grade; the walls are thoroughly waterproofed with membrane waterproofing, and are lined inside with hollow tile. There are four rooms in the building—one firing room and a store room. Conduits are laid in the concrete walls of the range for telephones, instrument wiring, and electric lighting. Ventilation of the range is provided for by spacing louvres at intervals along each wall, while a suction fan is installed to dispose of the gases from the firing.

Ordnance Building

The ordnance inspection and stores building is of similar construction to the case and bullet inspection building, but is about 100 feet longer. The storehouse portion is separated from the inspection by a fire wall. Cartridge boxes are handled in this storehouse by an overhead trolley which also hoists them to the shipping platform. A system of asphalt roads and concrete walkways connects the various buildings and the several groups. The roof of the rifle range provides a runway for the electric trucks operating from the main manufacturing buildings group to the loading buildings. Two railroad sidings and a crossover give a length of 5,000 feet of siding at the plant, with a 100-ton track scale near the point at which the track enters the grounds, thus allowing the ready weighing of both incoming and outgoing materials.

Fabrication and Erection

In erecting the steel work for the plant

the small size of the buildings and the uniformity of the trusses made assembly comparatively simple. The trusses were transported to the site completely fabricated and assembled, and they were erected by means of an ordinary wood derrick, working on temporary rails. Poling was resorted to in only a few instances. The details of the operation were so simple that no unusual or special methods were devised. For pouring the concrete roof slabs a large tower and chutes were employed, the tower being in the neighborhood of 225 feet high. Two towers were built, although it developed that only one was needed. This tower was used, in addition, to feed a screen beside it, which separated the sand from the gravel, the latter having been found to run rather high in sand. The one tower had sufficient radius of action to cover almost the entire plant, with the exception of some outlying or isolated jobs. The



CAR DEPARTMENT ACTIVITIES, C.P.R. ANGUS SHOPS, MONTREAL.

centering for the roof slabs was made in units in the shop, according to the plans of the roof layout, this being possible on account of the uniformity of truss and girder spacing. These forms were well oiled before use, and were employed over again from three to four times.

The excavation was, in the main, carried out by trenching machines. The foundations were plain walls, without spread footings, so that the side walls of the trench made forms for the concrete. The quality of the clay was such as to prevent any appreciable sloughing. The trenching machine was also used to excavate the range tunnel, the machine digging the core as well as the side trenches. It was the intention to use the earth walls as side forms for the concrete, and, although this was done in part, the rains caused washing, which necessitated separate form work.

Light, Heat and Power

The buildings are heated by direct radiation, making use of the Webster vacuum system. Wall radiation has been used throughout. A central boiler plant, consisting of four 150 horse power horizontal return tubular boilers, furnishes steam at 100 pounds pressure for heating and manufacturing purposes, this pressure being reduced at the several buildings to five pounds for heating purposes. Electric power is supplied by the Hydro-Electric Power Commission at 4,000 volts, 3-phase, 60-cycle, and is converted in the arsenal substation to 550 volts for power wiring and 220-110 volts for lighting. The lighting of all buildings has been carefully studied in relation to the machinery layout. In the loading building, extra precautions, including vapor-proof fixtures, have been employed to meet the dangerous conditions existing. Direct current is to be supplied for charging motor trucks, instrument batteries, and batteries for electrolytic work in the laboratory.

Ten toilet units have been installed, so located as to be most accessible. Automatic flushing water closets and stall urinals have been adopted, and the lavatories are the barrack room type, in enamelled iron. Fire protection is provided in the yards by means of three-way hose hydrants and hose-houses, with full equipment of hose, nozzles, wrenches, axes, and crowbars. Portable hose-reels, containing 1,000 feet of hose, are located near each group of buildings. Hose outlets are provided in the buildings, with reels containing 100 feet of 2½-in. linen hose. Small hand fire extinguishers are placed in all buildings.

Production Equipment

The brass foundry will contain forty fires in one battery, ten of which are to be used for eupro-nickel and the remainder for brass. Square fires were adopted, as coke only is used in firing. A 5 ft. x 150 ft. steel stack, lined with fire brick to the top, provides ample draft. A direct motor-driven alligator shear is placed in the foundry to cut up copper pig and scrap metal. A convenient scale is provided to weigh out charges.

The gas plant is equipped with three anthracite producers, having a capacity of 115,000 cubic feet of gas per hour. Hot gas from two of the producers is used in the large annealing furnaces in the rolling mill without scrubbing, but the gas from the third

producer is scrubbed, as this gas is used in the case-annealing and the tempering furnaces.

The rolling mill is equipped with one direct motor-driven alligator shear and one small trimming shear. A weighing scale is convenient for weighing trucks of metal for checking. There are two annealing furnaces or mufles, one single and one twin, and both are double-end. They are under-fired, using hot producer gas. The mills are made up of two stands, one breaking down and one finishing, direct-driven through herring-bone gears by a 250 horse-power motor. The usual immersing, pickling, and washing tanks are installed. In the rolling mill are also installed the first cupping presses for both cupro-nickel and brass.

The bullet plant houses all of the special bullet making machinery, same being arranged so that the flow of material is always progressing toward the inspection end. The lead extrusion press and equipment are also housed in this building. An aluminum extrusion press ordered from Quebec arsenal was made over into a lead extrusion press to make six reels of lead wire at one time.

The case plant contains all of the special machines with which to make complete brass cartridge cases. This machinery is likewise laid out for straight-line operation with minimum trucking.

The transmission equipment is of the latest type, employing a special hanger with turned plungers and using ball bearings. The shafting is turned and ground. The group drive system is employed.

The case washing plant equipment consists of fifty tumbling barrels for case washing, five special gas-fired annealing furnaces, and four case dyers, using indirect steam heat. Hot water and soap solutions are provided from the overhead tanks. Overhead mono-rail systems for handling cases to and from the annealing furnaces and into the immersion tanks are installed. All floors in this department are drained.

The tool room and machine shop are housed in one building, the tool room at one end and the machine shop at the other, with the tempering and grinding rooms between. Gas-fired tempering furnaces are installed. A small blacksmith shop and pipe shop is housed in a separate building. This shop is equipped with a motor-driven pipe machine to cut up 8-inch pipe, two down-draft forges, and a power hammer.

The carpenter shop for the manufacture of ammunition boxes, work boxes, etc., is equipped with the latest types of direct-driven woodworking tools. This shop has a capacity of 300 ammunition boxes per day. In connection is a complete tinsmith's equipment, with which to line the ammunition boxes with the usual waterproof lining of tin.

The loading and assembling plants require highly specialized equipment, and this is arranged for group drive. To avoid explosions due to sparks from either induced or static currents, thorough grounding has been provided. The drying of fulminate of mercury and potassium chlorate—always a dangerous operation—will be done at the Lindsay arsenal by means of vacuum driers, which perform their work efficiently and quickly and reduce to a minimum the danger from explosion of these substances.

The elevating hand-truck system will be used in handling the bulk of the materials in each unit. Between the manufacturing and loading buildings, storage battery tractors will be employed, each capable of hauling several trailers, and of operating ten hours continuously without recharging. Both the electric tractors and elevating trucks are, we understand, recent developments by Canadian manufacturers.

Lightning Protection

Much study was devoted to the lightning protection of the magazines, loading, and fulminate buildings. High steel poles similar to flag poles are placed at the side of each building, extending down deep into the earth, to assure good ground connection. The lightning poles are about thirty feet higher than the building. To collect any leakage of lightning, stout

rods are placed in a loop or ring and thoroughly grounded, top and bottom.

Materials and machinery of Canadian manufacture have been in every case given preference, and only such products as could not be obtained in Canada were purchased in the United States.

Lieut.-Col. A. P. Deroche, R.C.E., Director of works and buildings, is in charge of the building work for the Militia Department, assisted by Mr. Clarence Noble, as supervising engineer. Lieut.-Col. S. S. Weatherbee, of the Militia Department, as superintendent of the plant, is in charge of the manufacturing equipment. Under the direction of this staff the engineering, architectural, and construction work was performed by Westinghouse, Church, Kerr & Co., Montreal and New York, to whom we are indebted for the foregoing data.

FRICITION CLUTCHES—II.*

By W. G. Gass.

IN our Jan. 18 issue a resume was given of the different types of friction clutches manufactured, examples of which are to be found installed in lesser or greater number as part of the transmission equipment of general industrial and metal-working plants. The driving surface feature was discussed at some length in the same issue.

Clearances

Clearance is the main difficulty in the general run of clutches, and the smallness of it is the cause of a considerable amount of wear when running out of gear. In all cases where the setting-up is done by screws, the clearance between the driving part and the driven is a relatively small amount. The cone gives the largest amount of any, and on that score alone is the best. In segment

clutches, both inside and outside band clutches and plate clutches, it is a very serious problem. In the majority of these where a screw is used, the usual amount of rotation of the screws is about 1/8th of a revolution, and if screws of, say, 1/4 in. pitch are used, right and left hand, the movement given to the segment is 1-16 in. of an inch 1-32nd on each side, and that represents the clearance when the clutch is out of gear; the actual clearance

is less than this owing to the shape of the segments.

*Read before the Manchester Association of Engineers.



GROUP OF FEMALE EMPLOYEES, CAR DEPARTMENT, C.P.R. ANGUS SHOPS, MONTREAL.

lightning rods are placed on the highest point of each building. All metal in the building, including machines, shafting structural steel, etc., is con-

Setting Up Gear

In all cases the action of setting up a clutch is the conversion of a sliding movement along the shaft carrying the clutch into a pressure between the clutch surfaces. This may be properly divided into two portions, the first that which is in the clutch itself, and the other by which the power for operation is applied. In the majority of clutches the locking and concentration of power obtained by the toggle motion is the one mostly adopted, and when once set up has no tendency to slip back. It requires in every case an adjustment by means of a screw which can be set so as to bring the levers in the correct position to give the requisite pressure on the surface.

In most of the internal and external segment and band clutches the adjustment is obtained by moving the main nuts a portion of a revolution and re-locking—the nut having a serrated rim with a locking pin. In plate clutches it is generally done by using the adjustment screw at the point where the pressure to the plates is applied. In others, the forcing of the surfaces in contact is done by a wedge, having at its larger width a parallel portion which takes the end thrust off when the clutch is set up. The wedge is flat in some and circular in others.

With both the toggle point and the wedge, a sliding block is necessary to transmit the power from the stationary lever to the rotating shaft carrying the clutch. In the majority of cases the power is applied to the clutch to set it in gear, but, in others, the power is applied to release it or put it out of gear, the clutch being kept in gear by means of springs. Motor car clutches are the most common examples of this kind. For general machine driving, where a rapid movement is required for operating the clutch, a lever is usually employed, and if the leverage be sufficient, is quite satisfactory. It enables the power to be applied quickly and as quickly released, and where it is desired to give a slight movement to the machine, and also where the clutch is put in gear and released many times. Where a clutch is in gear for long periods, a screw and quadrant is mostly used. This is as generally fitted to internal combustion engine drives. It gives an easier starting movement because the pressure can be more gradually applied, but it is much slower both at starting and releasing. Where the lever is used, particularly on a heavy clutch, it requires a strong pull on the part of the attendant to put the clutch in gear. The trouble with all setting-up gears is the wear on the pins and lost motion due to clearance in bearings.

Pressure on Working Faces

This is the crucial point in the effi-

ciency of any clutch and its power to drive, for unless the necessary pressure exists between the frictional faces the clutch cannot transmit its power, and it is here where so much trouble arises in the use of any form of friction clutch. The power of any clutch is of course dependent on the co-efficient of friction between the surfaces, and whether they are dry or lubricated, and it is this factor which so materially affects any formulae for the power of a clutch. The co-efficient of friction varies greatly with the state of the surfaces, and, after the surfaces become glazed the power of the clutch drops in unison.

It is usually considered that if an actual pressure of 50 lbs. per square inch can be put on the surfaces it is as much as is desirable for good working conditions; but, if for any reason a less pressure is put on than that required to transmit the power, a clutch will, if it begins to slip, grind itself away quickly, and in the spring centre type grind away all the available spring in the metal. On looking at the action of the toggle joint it will be seen that the travel of the portions of the clutch being set up is very slight at the end of the movement, when the thrust link of the toggle is approaching the vertical. Pins are essential, and, in spite of all that can be done, will wear, so that if a clutch is set up correctly a very small wear on the pins and links of the toggle will rapidly reduce the effective pressure of the faces, even without taking into account the wear on the frictional surfaces.

It is, therefore, very necessary to keep a watch on a clutch to see that any wear which may take place is followed up, if the life of a clutch is to be as long as it ought to be. Where the pressure on the surface is due to springs, and these usually are in direct thrust, then they will follow up a considerable amount of wear themselves. It appears from this as though springs were the best, but they are only good where conditions are suitable, and this is not generally so for driving machines. The remarks about wear apply equally to wedge setting up surface. The power transmitted is proportional to the speed of rotation, and a clutch which will transmit 10 horse power at 100 revs. will of course transmit 50 horse power at 500 revs.

Lubrication

In clutches, as in everything else, lubrication is of the greatest importance, and more particularly where the clutch is running idle for a considerable part of its time. If the outside portion of the clutch is the driven part, it runs on the shaft and may have to be stationary while the shaft rotates in the clutch bushes; or, if the outside is the driver

it has to run loosely on a stationary shaft. This is a fruitful source of trouble with many clutches, and the lubrication of these bushes requires the closest attention, both in design and on the part of the attendant. If the driven portion has to be stationary while the shaft runs in it, there is a tendency for the shaft to wear a groove in the bush, and, when this starts, it rapidly grows worse as this part always seems to stop at the same point and be worn oval; while if the driving portion has to run loose on a stationary shaft, the bush wears larger and affects the clearances, even sometimes becoming so bad that the friction surfaces never run clear and are always rubbing. When in gear the lubrication is not required, and the oil is liable to be driven out of the bearing surfaces and so be missing when wanted.

In starting up any friction clutch a certain amount of rubbing takes place, and when two metal surfaces rub on one another fine particles of metal are given off. These, in an enclosed chamber, cannot get away and so become mixed with the lubricant, and form an excellent abrasive which does not increase the life of the parts. Another peculiarity of lubrication in the case of plate clutches is that where the resistance to the idle clutch is not very great, if the oil becomes thick the plates adhere because all the air is driven out between them, and the resistance may not be able to make the clutch stop. Springs between the plates have been tried to get over this, but the results have not been very satisfactory. Excessive lubrication also reduces the driving power materially. Solid grease has much to be said on its behalf for lubrication of clutch hubs, but it is often difficult to employ it satisfactorily.



DETECTING FAULTS IN CASTINGS

DETECTING the presence of internal defects in iron and steel castings accomplished by a current supplied from a small alternator to the primary winding of an induction coil, this induces in the secondary winding a current which is passed through the coils of two horse-shoe magnets, mounted at a fixed distance apart and movable to and fro over the surface of the casting. The fields of both magnets are affected uniformly if the structure is homogeneous. Defects, however, will disturb the lines of force from the nearest magnet. In a vibrating sounder, connected to a secondary coil on the magnet, the tone will differ in pitch from that given out from the corresponding sounder connected to the other magnet. Amplification of sound is secured by microphone attachments, enabling the observer, by means of telephone receivers, to detect the locality of hidden flaws as the magnets are moved over the casting.

EDITORIAL CORRESPONDENCE

Embracing the Further Discussion of Previously Published Articles, Inquiries for General Information, Observations and Suggestions—Your Co-operation is Invited

BASE FINISHING BAR

By J. A. S.

MANY manufacturers have experienced great difficulty in finishing the inside profile of 4.5 in. high explosive shells. The high cost of tool steel and the excessive wear on the point of the tool, together with the strict specifications regarding the finish of this portion of the bore, require the best efforts of shell makers to devise efficient means for overcoming this trouble, and eliminating as far as possible, all trace of tool or chatter marks.

The sketch herewith shows the method adopted by one firm, first as an experiment, and afterwards as part of the standard equipment for all machines on the boring operation. The care required in maintaining the efficiency of the spade tools is not only an expensive factor of shell production, but in many instances the loss of time through excessive grinding tends to curtail the output. As the wear on the tool is greatest at the nose, it is this portion

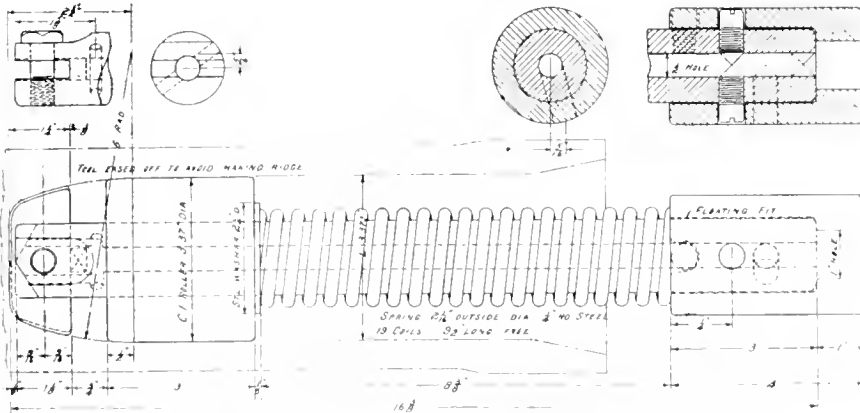

SHELL BASE INTERIOR FINISHING BAR

that quickly loses its proper shape, and the purpose of the tool here illustrated is to give increased life to the finishing reamer and at the same time leave the base of the bore the exact shape and free from objectionable roughness. The short section of tool has the exact shape of the base and extends a short distance along the contour. The duty required of this tool is very light and is further assisted by the roller that steadies the bar while the tool is cutting. This roller rides free upon the bar and is slightly smaller than the bore of the shell, a short portion at the front being turned to fit the finished profile. The spring shown, acting on the steel washer, forces the roller against the profile and holds the bar in a central position, while serving as a support close up to the working point. The bar is not held rigid but has a floating fit in the turret. This device

is proving most efficient and previous troubles are almost entirely eliminated. Provision for supplying cutting compound is shown in the sketch although experience has shown that the tool can be run dry with equal satisfaction.



TENSILE STRENGTH OF ROUND STEEL RODS

By N. G. Near.

THE scale illustrated will be found handy for determining the strength of round steel rods in tension. Simply glance across from column A to column B, and the strength is given for any diameter from 1-100 of an inch to 6 inches. For example: "What is the safe strength of a steel rod one inch in diameter?" Column B shows it to be 12,500 pounds.

The scale is based on 16,000 pounds per sq. inch, which is the commonly used safe strength for steel. Inversely, the

practice" the purpose of a chimney or stack is to "make the fire burn," in other words, to provide sufficient draught to produce complete combustion of the fuel under the boiler. Also, in the second case it carries off all obnoxious consumed or unconsumed gases. So far, I agree with our friend who now remarks, "so far so good, but this leaves in many cases much to be desired." I would like to ask what it is that is left so desirable? To continue, we read that the most efficient heating is secured by reducing fuel to carbonic acid gas. Quite true, but to produce this state in the furnace, our friend states that it is necessary "that large volumes of air must be drawn through the fire at comparatively low velocity." This statement is extremely broad, even omitting the fact that the information given is "general." We know that, for every pound of fuel consumed, a certain determinate amount of air is necessary for complete combustion. Perfect combustion is attained when the correct amount of air is admitted through the fire and also over the fire.

The next paragraph in the article says that, "The best method of providing the necessary air for combustion is by means of an exhaust fan." Before proceeding further, I would like to ask, what the difference between the two draughts is to the furnace, supposing both are designed to produce the same pressure, or, whether our friend considers that a chimney draught is superior

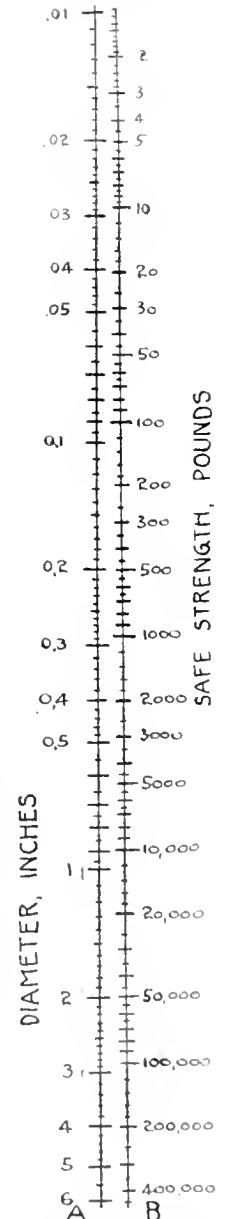

ROUND STEEL RODS CHART FOR TENSILE STRENGTH

scale may be used to advantage when determining the size of rod necessary to withstand a certain stress. For example, "What diameter of rod should be used to hold up 50,000 pounds?" The answer is, a 2-inch rod.



OBTAINING DRAFT WITHOUT HIGH CHIMNEYS

By E. T. S.

ON page 82 of your issue of February 1 is a short article entitled, "Obtaining Draught Without High Chimneys," that merits, in my opinion, more than ordinary attention, by reason that the author either has discovered something radically new in draught producing apparatus, or else he omitted to localise the case in question, in which case, the term "ordinary practice" is out of place.

Now, it is a fact that in "ordinary

to a fan draught by reason of its origin alone. The question is absurd, because if either be designed to give a certain draft in inches, the furnace cannot detect the difference.

The subject is a live one to-day, even as to the merits of the two systems. The fan system is favored chiefly on account of the low installation cost. The chimney is high in first cost, but has a maintenance cost of practically nil; on the other hand, maintenance cost of an induced fan system is endless. In this country where we are subject to severe winter temperatures, most of us drive our boilers pretty hard in the winter. The fan is speeded up above ordinary, and, if anything happens it is liable to be serious. The chimney acts in a way, more or less automatically with you.

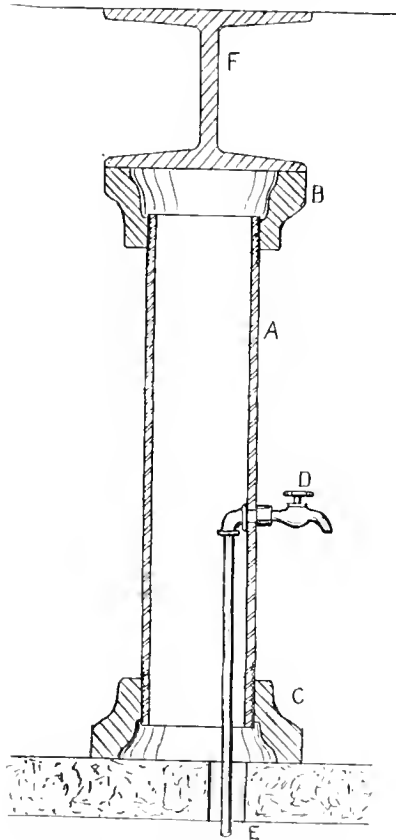

ADJUSTABLE SUPPORTING POST.

The intensity of the draught depends on the difference between the inside and outside temperatures, and so up to a certain point the draught increases as it gets colder.

I do not pretend to understand our friend's system of stacked brushwood kept watered, unless it is intended at the air intake end of a forced draught system. Perhaps he will enlighten me?

I have written more than I intended, but it must be obvious to anyone that now-a-days a stack is not just "guessed at" for size or anything else, any more than an induced draft or forced draft system would be installed so thoughtlessly. It is the cost, the ultimate cost that counts, and these involve careful calculations and painstaking consideration.

ADJUSTABLE SUPPORTING POST

By L. U. N.

AN adjustable pipe post is shown in the accompanying sketch, made from 6-inch steam pipe threaded right hand on one end and left hand on the other. Two heavy cast iron flanges are shown on the ends at B and C. This post can be placed under a ceiling or I beam already in place and by using pipe tongs to unscrew the pipe a few turns, a tight bearing can be made, the flanges being held with chain tongs while the pipe is being unscrewed.

In the post shown, a hole has been made in the concrete floor at E large enough to allow the elbow on the water pipe to pass through, a hole being drilled in the post to allow a nipple to pass through freely, and a drinking tap connected as shown at D.



EXAMPLES OF FORM GRINDING

FORM grinding is coming into more general use for the rapid but accurate production of irregular shaped or formed surfaces. The operations employed may be cylindrical, surface, internal or even occasionally off-hand.

The pins on crankshafts are roughed from the forging and finish ground on cylindrical grinding machines. The fillets are formed by the grinding wheel.

The cams on an integral cam shaft are another example of form grinding. Here the wheel face is not formed but parallel to the spindle. The cam is formed by means of the rotation of a master cam against a roller which actuates the cam shaft so that the cams are properly formed.

Cast iron pulleys may now be crowned by means of a formed grinding wheel. This method of crowning with a curved face is much superior to the old method of turning two flat faces, with a sharp ridge in the centre. The round crown is easier on belts and makes a far more powerful drive.

Grinding the nose of shrapnel and high explosive shells is a new and interesting development of form grinding. The face of the grinding wheel is formed by means of a radial truing device to the exact curvature of the nose of the shell and fed straight into it.

Among other articles that are frequently "form ground" might be listed, valve stems, cream separator bowl shells, rifle barrels, transmission shafts, electric starter and armature shafts and other multiple diameter shafts.

The grinding of marble mouldings on a planer type surface grinding machine with a formed wheel makes possible some of the beautiful marble interior decorations seen in our latest offices and public buildings. A series of formed grinding wheels may also be used cylindrically in shaping marble columns, balustrades or pilasters used in ornamental architecture.

In the very latest machinery for the accurate forming and finishing of gear teeth, the designer has again called upon the grinding wheel. Now formed grinding wheels are employed for this pur-

pose with the result that our gears are running quieter and more smoothly. Large cast iron gear teeth are occasionally roughly formed by means of hand grinding.

One of the most important and far reaching applications of form grinding is found in the gumming or sharpening of circular and band saws. This operation is so common that we seldom think of it as form grinding, but, nevertheless, the wheel is formed so that the teeth of the saw may be properly shaped.

The salvaging of worn out saws, cutters and reamers again calls upon some operation of form grinding to make these tools practically as useful as they were when new.

Grinding the groove in ball races is a form of grinding operation, whether it is done cylindrically, internally, or by surface grinding. A formed grinding wheel is used and these operations call for very accurate and smooth work.

The grinding of splined transmission shafts presents, perhaps, the most difficult kind of form grinding. It is necessary to grind both straight and circular surfaces at one traverse of the wheel, and is essentially a surface grinding operation. Of course a special truing device is necessary to keep the faces of the grinding wheel trued to proper shape.—*Grits and Grinds.*



HERAULT FURNACE INSTALLATION

AMONG recent installations of Herauld furnaces in Canada, the following are to be noted:—

The Dominion Steel Foundry Co. Hamilton, Ont., are installing four 6-ton furnaces for making war material. After the war, metal from these furnaces will be used to make wheels, tires and axles.

Armstrong, Whitworth, of Canada, Ltd., are installing one more 6-ton furnace, making three of this type and capacity, at their plant, Longueuil, Que. War material, as well as tires, wheels and axles constitute the product.

The Imperial Munitions Board will install ten 6-ton furnaces in their new plant at Toronto. The steel will be used for making war material.



The shrinkage of manganese steel amounts to 5-16 in. per foot as against 3-16 in. to 1/4 in. in ordinary steel foundry practice.



When several furnaces are tapped into one ladle before pouring, the content of the ladle is apt to become too cool. According to the *Iron and Coal Trades Review*, the metal can be kept hot very conveniently by using an apparatus invented by M. C. A. Keller, of Paris, consisting of two electrodes which can be raised and lowered from a crane or gantry. Current passing from one electrode to the other through the contents of the ladle generates enough heat to bring the contents back to the proper pouring temperature.

Safe Practice at Blast Furnaces and Its Development-III.

By Frederick H. Willcox

In its efforts to increase safety in the metallurgical industries, the Bureau of Mines, Washington, D.C., has been studying the causes of accidents at blast furnace plants also methods for their prevention. This article describes the known dangers and makes suggestion of means whereby the risk of accident may be lessened or, better still, wholly avoided.

THE STOCK-HOUSE CREW

ROD the furnace regularly, and, in case it is hanging or stiff, report to the foreman promptly. If anyone is working in the skip pit, or the skip incline, hoist, or skip, don't move the skip, except under direction and after giving warning. If an oiler or "handy man" is working on the sheave wheels, bell rods, hoppers, distributor mechanism, or bell-rod cylinders, do not lower the bells except on signal from those on top. Never start the skip or hoist cage until you receive the proper signal, unless you have all regular charging operations in sight, and then signals are not required. When the blast is off, or when the furnace is shut down and men are working about the top or bottom, do not fill the furnace or lower the bells without warning the men away from the tuyères and hoppers on top, and then only under the direction of the foreman. If the furnace is being shut down or if it is working irregularly and stops taking charges on account of hanging and slipping, do not put wet ore on the bell; at many plants it is considered dangerous to dump wet ore when the furnace is low. Report anything about the skips, bells, or indicators that does not seem right, such as skips striking the bumper blocks too hard, or frayed cables, irregular, slow, or quick movement of the bells, or water in steam lines. By early notice an accident or possibly a hazardous delay may be avoided. Never let anyone go up the skip incline to the top alone.

Scale Car Operators

Scale-car operators should watch for stock-house cleaners or others crossing the track and should always have the car under control. Watch out for overhead obstructions. Let the furnace millwright or electrician do all repair work on the car. Be careful not to leave ore or stone on the edges of the chutes; many accidents are caused by stock falling from the chutes. When barring or punching at the chutes or doors of the bins be careful to avoid a rush of ore or stone falling on your foot. Do not open the door of a nearly empty bin or get under it just as the car doors are dropped on the trestle; the material may easily fall through and bruise you, or if it is fine dust or sinter, burn you. Wear goggles when the coke is very dusty or when breaking ore or limestone. If steam is used to thaw ore in the bins or piles be sure that the hose is strong and in good condition. See that no one is in line with the nozzle when you turn the steam on. If gas is used see that it stays lit and that a pocket of gas does not accumulate. Do not light gas by hand with

a match, use burning waste, placed on the floor or in the chute.

Ore Buggy Accidents

Most accidents with ore buggies happen from catching the fingers between the buggy handle and a column, wall, or other obstruction. Watch out for this and use safety handles. Be careful not to let the buggy leg come down on your heel, or to run the wheel over someone's foot. Never race with a buggy, you may easily lose control of it and receive a wrench, strain, or bruise. Watch that your fingers or feet do not get caught between a lump of stone or ore from the chute and the buggy or floor. Don't undercut an ore or stone pile, or let the stock lodge above you, keep it knocked down with a bar. Never stand close to the elevator pit as the cage comes down, ready to take the buggy off the instant the cage comes to rest, as many men have had their feet crushed in this way by getting them caught between the cage and the floor sill. Don't try to get on the cage before it has come to rest, or after the signal for hoisting has been given.

When it is necessary to clean the skip pit, notify the skip operator and do not

on or off the car when it is moving.

When you enter the motor house or hoist-engine room notify the skip operator, both on entering and leaving. Stay at your own place of duty, even when you are "spelled off." Keep away from the cast house and stoves unless you are required to go there to help. Report all bad places to the foreman, such as dark corners, overhead obstructions, poor track, holes, and unsatisfactory bin doors. Be sure to report every injury, as even a slight injury if neglected may have serious or fatal results. Even a bit of coke dust may seriously injure the eye if not taken out right away. If a man receives an electric shock free him from the source of current, being careful not to get a shock yourself, give him artificial respiration at once, and send for the foreman. Similar first aid is needed if anyone becomes gassed while working on top.

Hand Filled Furnaces

On hand-filled furnaces, top fillers should remember not to step over trap or lift doors at the top of elevator shafts while the elevator is running. The safety of many men about a furnace plant depends indirectly on the care and



FIG. 21. SAFEST WAY OF USING POLE TO PLACE CARS

go into the pit until he tells you to. Avoid walking under bin doors and chutes. Keep off the scale-car track and watch for the car when crossing the track. Don't stand on the track when signaling the car operator. Be careful that your bar does not touch a third rail or trolley wire. It is best not to ride on the scale car, and you should never jump

interest the stock-house crew take in their work. Careful weighing, regular charging, reporting any difference in appearance or quality of coke or limestone, and constant watching of the movement of the charge in the furnace will prevent many slips, "messes," and dangerous work at the tuyères, tapping hole, and furnace top.

Trestle Gang and Yardmen

Watch for the lorry car, locomotives, and cranes, and do not go under the ore bridge just before ore is dumped into the bins. Do not jump on or off moving cars; many men are hurt that way every year. Never sit on or near the track or bridge rails to rest; find a safe place. When you hear the warning whistle at the furnace get out of the car at once and under shelter as it means the furnace is hanging and may slip. When ore is being dynamited and a warning is shouted, get under cover and stay there until material has stopped falling. Do not try to jump across the bins from rail to rail; use the crossovers. They were put there to use, and the minute saved by not using them is worth less than the good example set by using them.

Do not use a pole in spotting cars with a transfer car or locomotive on an adjoining track, use a cable with safety hand locks. If there is no cable and a pole must be used, stand on the same side of the pole that the coupler of the car is on (Fig. 21). Be careful in pinching cars on the trestle, you may fall and receive a severe injury. Pinch a car the way the foreman has shown you, and report pinch bars with smooth heels or dull points to the toolman or foreman. The safest pinch bar (Fig. 22) is one fitted with a disk and tool-steel heel. When turning on a steam jet to thaw ore see that no one is in line with the jet; use a clamp to hold the nozzle, and avoid working with worn hose. Watch that cinders from trestle locomotives, or hot coke, do not start fires in the coke bins or walks. A safety car wrench for opening drop doors on cars is shown in Fig. 23.



FIG. 22. TRESTLE LABORER USING SAFETY CAR WRENCH. WHEN THE SHAFT BEGINS TO REVOLVE, THE HINGED JAW RELEASES. DISC IS TO PREVENT MAN'S HAND STRIKING CAR, AND SHORT BEND ON END OF HANDLE PREVENTS USE OF PIPE EXTENSION.

Loaded Car Drop Doors

It is dangerous to open drop doors on loaded cars unless you know how. Do not try to do it until you have been shown and, if possible, have watched for a day men who knew how. Before getting into a car to unload it, or crawling under a car to work on the drop doors, make sure, by asking the foreman or "straw boss," that the car will not be moved. Wait until the doors are dropped before

going on top of material in cars to be unloaded. When unloading hopper cars, do not stand over doors or on the edge of the material; it may slip and carry you down into the bin, where you may be suffocated or severely injured. Obtain a firm footing in the bottom of the car between the doors, or be sure of a firm hold on the side of the car. By all means wear a belt and safety line if these are provided. Do not undercut material any more than is necessary and watch that the lumps do not catch you. Be very cautious in opening the doors of cars loaded with flue dust; if dry, it will fly out. Avoid stepping on flue dust in cars, for even apparently wet dust may be dry and hot beneath and cave when you step on it. Always get out of a car the same way you get in; do not crawl through the doors in the bottom of the car (Fig. 24).

Miscellaneous Precautions

Before you drop material into empty or nearly empty bins, notify the stock-house crew so they can keep clear of falling material, and be sure that the bin doors are closed. In poking ore in bins and chutes see that you will not get caught in case a fall of ore catches the bar. Never go into any bin to shove material or to clean the bin unless you have a belt with a life line attached to a girder or tie (see Fig. 25). Use a flag or track torpedo to protect the bin you are working in, or ask the foreman for a watcher to hold the line and warn men not to dump material in the bin or run cars over it.

Do not work with a pick or sledge if the handle is cracked or the head loose. Do not use a bar, wedge, or sledge having burrs or splinters; give it to the toolman. Watch that your tools do not touch electric conductors. When carry-

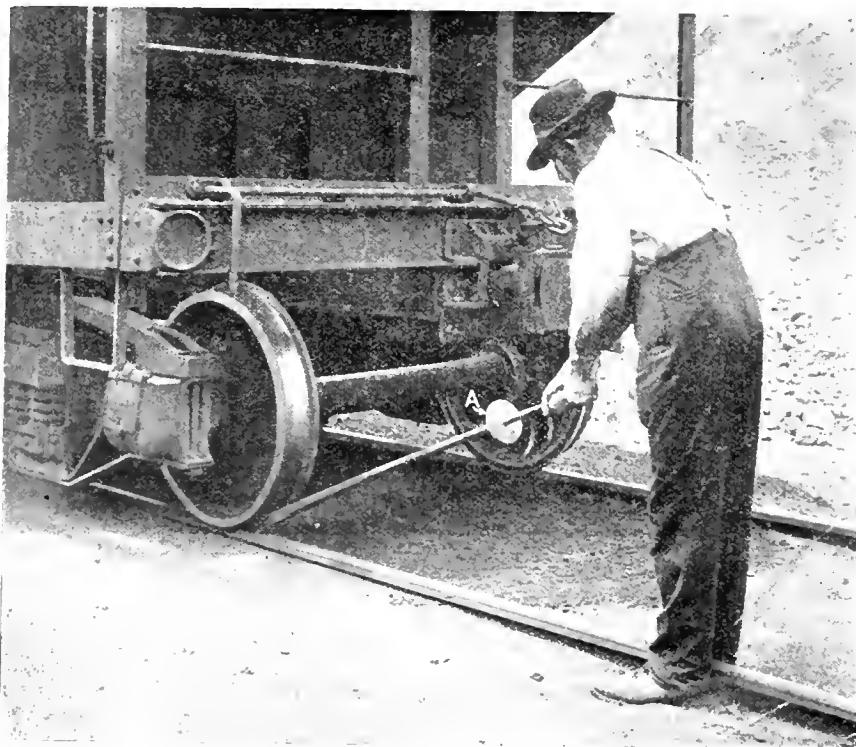

FIG. 23. TRESTLE LABORER USING SAFETY PINCH BAR FITTED WITH DISC, A. SHOULD THE BAR SLIP HIS KNUCKLES WILL BE PROTECTED.

ing bars, pipes, or other material through doors be careful so as not to strike persons passing by (see Fig. 26).

Avoid leaving tools, scrap, boards, lumps of ore or stone, or sheet iron, on the walks where they may cause some one to stumble, or fall into a bin or into the stock house. Coke forks or shovels should be placed with the edges or prongs pointing to the floor. Report to your foreman any rotten, loose, or burned planks in the walks, or defective lights. When you are set at new work be sure to ask about the work, the way to do it, and the dangers connected with it. Do not ignore danger signs; they mean what they say. Do not wrestle or play when at the plant, especially when on the trestle, where you may fall into a bin or the yard.

Men working in ditches and excavations should work far enough apart to avoid any risk of striking one another with picks or other tools. (See Fig. 27.)

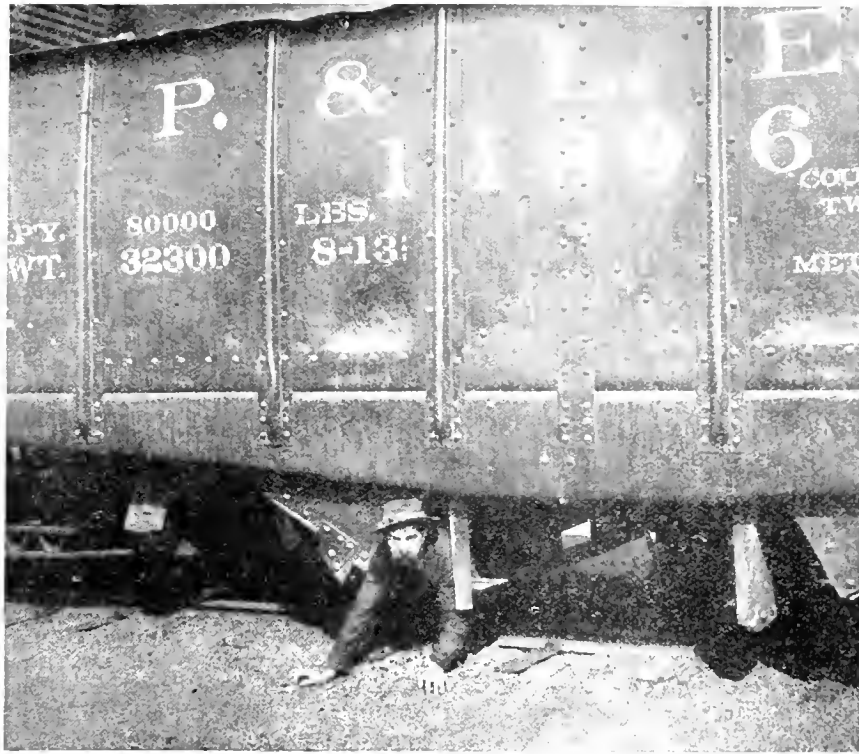

FIG. 24. UNSAFE PRACTICE: CRAWLING OUT OF HOPPER CAR THROUGH HOPPER OPENING.

even when leaving the job for a short time. (See Figs. 28 and 29.) If you are chipping concrete, wear goggles, as chips frequently fly in the eye. Don't undercut piles of ore or stone, or piles of frozen earth, sand, or other material. Don't undercut banks when excavating;

rubbish into cinder lades, as it may cause an explosion, and in turning a hose on a leaking cinder or iron ladle stand as far away as possible, as you may be scalded by steam or burned by an explosion or "shot" if the water hits molten iron. Avoid walking on ash

Stay out of east houses, pig machines, boiler houses, and other places where your work does not require you to go, and keep away from iron and cinder ladles when they are being shifted. Whenever possible, keep from under cranes in operation. Always warn the crane man before beginning to clean the tracks about the granulating pit, as he may accidentally drop some hot slag over the sides of the car unless he knows you are beneath, or scalding water may run from the grate bucket as it is carried over your head. Be careful in cleaning up about a loaded cinder ear, as steam and scalding water may escape suddenly from a drop door. Don't throw wet or damp



FIG. 25. PROPER EQUIPMENT FOR MAN WORKING IN ORE BIN. NOTE LIFE LINE ATTACHED TO HIS BODY AND TO CROSS BEAM OF BIN.



FIG. 26. SHOWING DANGER TO PASSERS BY WHEN CARRYING BARS, PIPES AND SIMILAR MATERIAL THROUGH DOORWAYS.

Before leaving an excavation for the night or for other work cover the hole with planks. Manhole covers should always be replaced when a job is done, or

keep them knocked down, test the edges with a bar and knock or pry any loose earth down (Fig. 30). Frozen ground is especially dangerous.

piles; they may be hot underneath and burn your feet if you break through. Keep your feet out of the dust when cleaning it up. In loading or unloading

cars, see that the gang planks or runways are in good condition and are properly placed and secured.

Be careful when handling heavy material or using tools (see Figs. 31 and 32), as most accidents about blast-furnace plants are caused in such work. When necessary to go on a roof or window ledge to clean windows always use a safety belt and a life line. When cleaning windows from a ladder do not over-reach; go down and move the ladder if necessary. Be sure that the ladder is resting squarely at the bottom so that it can not slip. If the ladder is a long one have some one steady it. Always have at the top a cross piece long enough to span the entire window. The cleaner you keep the yard the better and more safely everyone can do his work. Don't let piles of rubbish accumulate, or pieces of lumber, brickbats, scrap, and other material lay around, or leave tools about; some one may stumble over them. Fill up small holes and depressions and report promptly any steam or hot water puddles caused by leaky lines.

Pig-machine Men

Always wear goggles or a mask when working about the troughs while iron is being poured; be cautious when the molds are cold or if they have ice, snow, or water in them, and, especially when cinder is coming over, keep away as much as possible. When it is necessary to work under the strands to knock out the "stickers," keep from directly un-

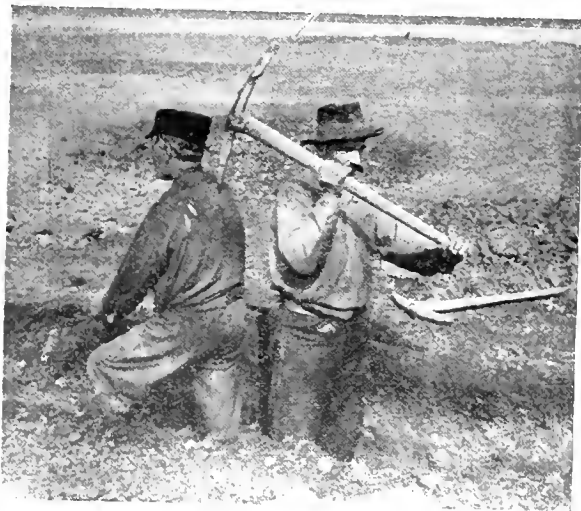

FIG. 27. EXCAVATION OR DITCHING, SHOWING LIABILITY TO SERIOUS ACCIDENT IF MEN WORK TOO CLOSE TOGETHER.

der the strand as much as possible, both the one you are working on and the adjoining strands. Men tending the lime vats and sprays should watch for stickers when it is necessary to go under the strands to adjust the sprays or to feed lime, while the machine is running. Aim to do such work between casts and shut off the steam when working about the sprays or vats. Before pouring, examine the top of the ladle to see that there is no solid crust of cinder or iron frozen over the hot metal. Such crusts should be broken with a warm,

dry bar, as otherwise the metal will splash badly when it breaks through the crust. Never operate the motors, clutches, or hoists for pouring ladles or running the strands unless it is your job, or unless you are told to do so by the foreman. Keep away from around the sprocket wheels. Remove the scrap and clean the rails between pouring ladles or casts. Don't try to save a few seconds by stepping on or across molds in motion or containing hot metal; use the walks or go around if necessary. Be sure that the bars you use with which to bar scrap out of the troughs are dry and warm, and avoid using short piling sticks. Before releasing the ladle after pouring, replace all safety dogs or legs in position.

When you are working about the rear of the machine, wear goggles to protect the eyes from flying chips of iron or lime dust. Use care in loading cars to prevent side loading, overloading and loading directly upon drop doors, and see that no pigs are left on the end frames where they may fall off.

When working on the pig-machine strands, or changing molds, see that motor switches are locked open, tagged with a danger sign, or that the clutch is fastened open. Avoid touching electric lines, motors, or light sockets, for where there is so much steam and metal floors as are about pig machines, you may get a severe electric shock or burn. Keep sledges, cutters, and other tools in good condition, be careful in using them, and watch your hands and feet when

handling molds or pigs. Report cuts, burns, or bruises promptly.

Ladle-House Men

Don't leave large pieces of scrap on the ladle spouts, they may cause accidents in shifting or pouring, and in removing them use a long bar and keep away from in front of the ladle; work from the side. Before trying to remove a bottom skull, clear away all overhanging rim or side skulls and knock out any loose bricks. The bottom skull will then come out more easily and safely. Before removing a skull or cleaning a ladle, be sure the ladle is securely blocked or propped. When trying to lift a rim skull out of a ladle with the crane, the hook may slip and strike you or cause you to fall. Watch all ladles for iron frozen on the rim or spouts, skulls, and "hot spots," or signs of failure on the lining whereby hot metal might break through. A thin place in the lining is usually shown by the ladle shell becoming rusty red.

Do not clean hot kish or metal from ladles onto damp ground; to do so may cause an explosion. When cleaning a ladle into the quenching pit use a long-handled scraper and keep as far back as possible. Take time to pull the cleanings out slowly and keep them from running out suddenly if they start to slide. There is no danger of an explosion if the cleanings are fed into the water intermittently and in small quantities and not too fast. An accumulation of unquenched ladle cleanings beneath the water or a rush of cleanings may explode. To guard against sparks or small splashes wear goggles or a mask. When playing a hose on hot scrap or ladle cleanings, stand as far away as possible to avoid steam or small explosions. If you dry ladles with gas, do not try to light the gas with a torch; kindle a small wood fire or throw burning waste on the ladle before turning the gas on. Always examine a relined



FIG. 28. WORKMAN LEAVING MANHOLE UNCOVERED



FIG. 29.—PASSER-BY FALLS IN MANHOLE LEFT OPEN BY OPERATOR

and dried ladle that has been standing about before using it; if it seems to be damp inside, build a fire in it or dry it again. A damp lining will probably cause boiling, leaks, or explosions of hot metal. Always report water in cinder ladles.

Do not work inside of a ladle without notifying the crane man or placing a sign to show him you are inside, so that he will not carry loaded buckets over you. Use hooks or tongs in handling heavy pieces of scrap. Gloves or hand leathers, except safety hand leathers, should not be used, as they may catch and cause you to fall. In hooking on scrap to be lifted with the crane see that you do not catch your hand. When breaking scrap with a steel drop ball get behind shelter and place danger signs to warn others from flying pieces. In steadying heavy crane buckets use a hook or a long-handled shovel. Do not stand close where you may be crushed or caught between the bucket and some other object.

Slag-dump Men

When dumping cinder ladles at dumps, pits, or conveyors, keep away from the front, as the cinder will splash to a great distance. Never pour cinder on flue dust or refuse coal; to do so may cause a great burst of flame or an explosion. Never try to remove a "sticker" or apparently solid skull from a cinder buggy or ladle that has just been brought from the furnace to the dump; the sticker is probably molten inside, and if it does not fall out itself when the ladle is tilted and you try to pry it out, it may burst and splash hot cinder on you. Before working on such a ladle report the sticker to the foreman. He will, if necessary, set the ladle aside long enough for the slag to harden, when it can be pried loose without danger from burns.



FIG. 31. UNSAFE WAY OF HOLDING BAR FOR A SLEDGE. MAN HOLDING BAR IS STANDING ON SAME SIDE AS STRIKER.

Engine Room Force

Before changing blowing engines on a furnace first notify the furnace blower unless it is an emergency change on account of a breakdown. In case of a stop at the furnace keep at least one engine turning over at sufficient speed to avoid any chance of its being stalled. Watch that the flywheel does not turn backward owing to the back pressure of the blast; few blowing engines will do this, however. By keeping an engine turning over against the butterfly valve in the cold-blast main with the snort valve open, there is the least chance for an explosion or fire in the cold-blast main and air tubs.

In case two or more furnaces are

blown from one room, attach a number to each engine showing the furnace it is blowing to avoid any possibility of confusion in checking the furnaces. When the furnace whistle is blown for a check, observe the signal light or number as well as the whistle before checking the furnace. In case of a shutdown when the engines are stopped, close the stop valves between the air tubs and the cold-blast main. In case there is a steam connection to the cold-blast main, examine the connections at the beginning of each turn or shift to see that both air and steam connections are in working order and that no steam is leaking into the main. Always be ready to turn steam into the blast main if the signal or word is given. Place numbers at each steam inlet to correspond to the furnace number. Always be ready to check the engines promptly; at times, conditions at the furnace demand throwing the snort valve open very quickly and getting the wind off as fast as possible.

Before entering a cylinder to make repairs, lock the steam throttle and the vacuum stop valves, place blocking in the cylinder, and block the flywheel fast. The drain valves should be opened prior to taking off the cylinder head. In undertaking repairs to gas engines, be sure that the gas valves and water seals to the engine are closed. It is essential that two men should work together in repairing gas-engine parts that are inside the cylinder, are near gas or inlet valves, exhaust lines, or are in enclosed places, such as basements and tunnels. Be prompt in shutting down gas engines when the signal is given, as there is even more danger involved in delay with gas engines than with steam engines.

Oilers and wipers should wear closely fitting clothing that can not be easily caught in the moving parts. In wiping and inspecting the engine, watch that you do not get caught by rocker arms,



FIG 30—MAN CUTTING TOO FAR BENEATH BANK OF EARTH; A DANGEROUS PRACTICE

wrist plates, eccentric rods, and Corliss or other valve mechanisms. Be careful that you do not slip on oily platforms and steps, and be prompt to report equipment out of order or in a condition dangerous to employees or the plant, such as valve wheels without lock nuts, steam leaks, worn or oil-soaked governor belts, broken steps or railings, defective indicators or gauges.

Remember that uniform and correct speed of the blowing engine has much to do with the regularity of the furnaces. Irregular speed causes slips and other serious troubles. Report immediately to the blower any trouble with the pumps and tuyere-water supply so that he may be prepared to take care of the furnace in case the flow of water becomes slack or fails.

Do not put any engine or machinery in motion without seeing whether anyone is in a position to get caught or struck. Do not work on electrical equipment or touch wires unless advised by

are in such a position that you may lose your balance and fall if the wrench slips.

ABRASIVES, ASBESTOS AND BRICK

ACCORDING to statistics compiled in "Mineral Resources of the United States, Calendar Year 1915," the production of abrasives increased by 33 per cent., the imports decreased by 26 per cent. The term abrasives comprises millstones, grindstones, oilstones, etc., emery and corundum, diatomaceous earth, kieselguhr, tripoli, pumice, and also diamond dust and bort. In value the emery and corundum exceed all the other products by far, and the low imports are primarily ascribed to the unsettled conditions in Turkey and Greece and to the war in general. Westchester county, New York, supplies most of the emery. Tripoli is the porous, almost

March, 1916, however, Canada put an embargo on shipments of asbestos to ports other than British and Allied; the embargo has since been modified, but American miners have been looking around, especially in Vermont, the asbestos of which occurs in the same rocks as in Canada.

SPECIAL TRIBUNAL FOR BUSINESS MEN

A DELEGATION representing Canadian manufacturers, wholesalers and retail merchants waited on Sir Robert Borden and Sir George Foster at Ottawa on Feb. 7, and asked for the establishment of a tribunal somewhat after the plan of the Railway Commission before which the producing and distributing interests of the country would have a right to go to answer charges affecting their business. The delegation which consisted of some forty members, was introduced by Senator Lynch Staunton, and was received by the two Ministers mentioned, and by Sir Thomas White, Hon. C. J. Doherty, Hon. J. D. Reid, and Hon. Martin Burrell.

What the business men want is a court before which they could answer charges as to price raising, the formation of combines, etc., instead of being brought before the common courts of the country as at present. The delegates stated that under the present system important business details sometimes have to be improperly divulged and that unwarranted odium attached to it for the merchant so accused. Such a tribunal as they proposed would report to the Government the merits of every case brought before it and that report could go to the Attorney-General of the province concerned, who would thus have before him the results of capable preliminary examination as a guide in prosecutions. The delegation, it is understood, also opposed the cost of living investigation as at present carried on.

Sir George Foster, in reply, asked the delegates to submit practical suggestions as to how what they asked could be carried out. If such suggestions are received, it is understood there is every possibility that such a tribunal as asked for would be created.

Shortage of Leather.—Canadian industry and ultimately Canadian consumers, are facing shortages of a number of commodities needed in production by this country. The latest to be heard from in this connection are the leather men, who waited on the Government in Ottawa, on Feb. 8, to ask that something be done to meet the scarcity of hides. A situation almost equally serious exists with regard to wool, while there is also a growing scarcity of machine parts, tool steel, tin sheets, wire rope, and a number of other such articles. These were formerly obtained from England and their import has been stopped by the English restriction of exports.



FIG. 22. SAFEST METHOD OF HOLDING A BAR.

the electrician. Let the electrician fix the lights. In working above, be careful not to drop tools or leave them where they may fall on someone below. Keep from under loads carried by cranes. When the crane is being used, one man only should have authority to signal the crane man to hoist. The crane man should try to hoist straight, but, as the crane is usually high, heavy loads may swing, so it is best to keep at a safe distance when he starts to hoist. Do not tighten bolts in leaking flanges on live steam lines except under the direction of the master mechanic. Be careful in placing a ladder before using it, and if there is any danger of its slipping have someone hold it. Do not carry tools or material up or down a ladder; use a hand-line. (See Figs. 8 to 10). Return mushroomed or burred chisels and other defective tools; report or remove rounded nuts and be careful not to use too large a wrench or one with spread jaws. Don't pull on a wrench when you

purely siliceous rock resulting from the leaching of highly siliceous limestones or of highly calcareous cherts. By silica the statistics of the United States Geological Survey understand quartz, sand, flints, and some of the abrasives just mentioned, all these materials being used in pottery and glass-making, as flux, and as fillers in acid towers, paints, soaps, etc. Sand-lime bricks are coming more into favor; nearly 180,000,000 of these bricks were made in 1915 and valued at \$1,135,104; the State of Michigan leads in this industry. The asbestos produced in the United States in 1915 amounted only to 1,731 short tons, valued at \$76,952; but the increase over the previous year in bulk was 39 per cent., and the increase in value over 300 per cent., the latter part being due chiefly to the mining in Arizona of chrysotile, an asbestos of the cross-fibre type which can be spun. So far asbestos had been exported from Canada to the United States free of duty. In

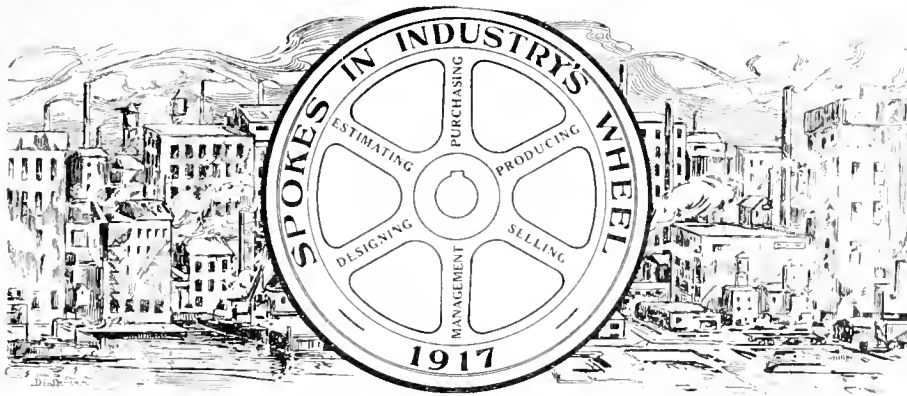

The constitution of industrial enterprise is largely departmental—"spokes in a wheel." This series of articles has for its object the featuring in a racy, interesting and instructive fashion, the training, experience and achievement of those who to-day are transmitting, effectively, energy in their capacity as "spokes in the wheels" of our metal-working establishments.

JAMES ALFRED STAIRS

THE Province of Nova Scotia, with its half million inhabitants, affords a typical example of modern industrial growth. At one period exclusively a farming and fishing region, the province possesses now something like 1,500 manufacturing establishments. The industrial ascendancy of Nova Scotia is broad based upon its immense deposits of coal, its forests, its farms, its fisheries, its water powers, and its strategic commercial situation as the Eastern gateway of Canada. Its position on the fringe of the Atlantic Ocean highway, and, therefore, its proximity by sea to either European or American markets, the year round, constitute, of course, a most valuable asset. That this was recognized by the early settlers and continues to be demonstrated by each succeeding generation, the present-day achievement record amply proves.

James Alfred Stairs, vice-president and works superintendent, the Eastern Steel Co., contracting engineers, New Glasgow, N.S., a "Spoke in Industry's Wheel," is a Nova Scotian, and while we know him to be quite proud of his being Canadian-born, we rather incline to the belief that the provincial feature of his birth is just as he would have wished it. That he has recognized the need for broadening his outlook and enlarging his experience, will, however, be apparent from the disciplinary schooling—educational, military and business, to which he has applied himself, also from his procuring, by travel, first-hand information concerning his own and other lands. He was born at Dartmouth, N.S., December 21, 1876, the eldest son of the late John F. Stairs and Charlotte (Fogo) Stairs, both of whom were Canadian-born. He was educated at private and public schools in Halifax, N.S.; attended Trinity College School, Port Hope, Ont.; and graduated from the Royal Military College, Kingston, Ont., in 1907, winning the non-commissioned officers' Sword of Honor for exemplary conduct and military discipline.

In the same year he became connected

with the Nova Scotia Steel & Coal Co. in the capacity of surveyor and draughtsman. From 1899 until 1901 he was draughtsman on construction work with the American Steel Hoop Co., resigning in the latter year to become night superintendent of the 10-inch and 16-inch Morgan merchant mills of the Duquesne Works of the Carnegie Steel Co. In 1902 he became chief draughtsman with E. L. McGary, consulting engineer, in which capacity he had charge of the construction of an open-hearth steel plant



JAMES ALFRED STAIRS.

and rolling mills for the Sharon Steel Hoop Co., and a manufacturing plant for the Standard Scale Co., at Beaver Falls, Pa. Following this, he joined the staff of the Lackawanna Steel Co., Buffalo, N.Y., as inspector for chief engineer during the construction of an open-hearth steel plant, a 32-inch slabbing mill, and a 48-inch universal plate mill, with their accessories of boilers, gas producers, etc.

Resigning this appointment in 1904,

Mr. Stairs returned to his native province and re-entered the employ of the Nova Scotia Steel & Coal Co. as assistant superintendent of their rolling mills at Trenton, near New Glasgow, being later acting superintendent. In 1909, he associated himself with D. P. Brown in the organization of the Brown Machine Co., with a view to carrying on a general engineering and foundry business. Four years later the Eastern Steel Co. was formed, the Brown Machine Co., and the Bailey-Underwood Co., manufacturers of agricultural implements, amalgamating under that title. Like most other metal-working plants in Canada during the past two years or more, the Eastern Steel Co. is for the most part engaged on munitions production, an output of 600 18-pdr. shrapnel and 250 4.5-inch H.E. shell per day being steadily maintained. In the adaptation of the plant to the successful manufacture of munitions, the experience of our "spoke" acquired in other directions, combined with his endowment of a clear appreciation of the fitness of things mechanical, were given unlimited opportunity.

Among the more important construction contracts on which Mr. Stairs has had direct charge, since 1909, may be noted the following:—Bank head at Albion Mine, and boiler house, Allan Shaft, Acadia Coal Co., Stellarton, N.S.; erection at Port au Port, Nfld., of loading plant for storing limestone for Dominion Iron & Steel Co.; fabrication and erection of steelwork for buildings of Acadia Sugar Refining Co., Dartmouth, N.S., all of the steel being fabricated in temporary shop on the site. A number of the columns on this job were 55 feet high and weighed 5½ tons each, while many of the girders weighed 8 tons each. The whole contract was completed between the months of May and November, a total of some 1,600 tons of material being handled.

Mr. Stairs is Conservative in politics and Presbyterian in religion. He holds the rank of Captain in 78th Battalion Canadian Militia; is past president, Nova Scotia Society of Engineers, and a member of Albion Lodge, A.F. & A. M. He is a strenuous advocate of protection and encouragement to both Canadian industries and to Canadian farmers. In 1906, he married Margaret E. Hillman, of Philadelphia, Pa., their home being in New Glasgow. In addition to travelling in the United States, he has made opportunity to visit Great Britain and France, thereby materially adding to his repertoire of men and things, and incidentally enlarging his usefulness as a citizen and manufacturing plant executive. In addition to his association with the Eastern Steel Co., he is director, Wm. Stairs, Son & Morrow, Ltd., Halifax, N.S.; director, Scotia Printers, Ltd., New Glasgow, N.S.; and president, Bedford Chambers, Ltd., Halifax, N.S.

"During 20 years' experience in different departments of steel plant work and constructional engineering," says Mr. Stairs, "I have found that the best way to accomplish anything is to first make up your mind that the proposition

is not going to beat you; then neither let extra hours nor minor obstacles stand in the way. Persistence and self-confidence will pull a man out of any hole. Money may be lost through errors of judgment, but a reputation for having finished a job counts for as much as cash profit, as one can always get another job if health holds.

The great problems to-day are handling men so as to develop a fighting spirit among them that will create enough initiative to clean up minor obstacles without appealing every time to the boss, and the ability of the latter to observe these men and reward them. Organization and control of a shop centres in the superintendent. A thoroughly efficient system of reports submitted daily is absolutely essential, as only by following up the information contained can the men be kept on the alert.

Technical education should be encouraged by all manufacturers, and technical papers be read closely, the advertisements as well as the editorial, as so many new and profitable devices are continually being offered, and should be taken advantage of.

“Every firm who can stand the expense should have instructors for their apprentices; in addition, apprentices should be paid to attend technical classes, where these are organized and are reasonably convenient.”



COMPRESSED AIR IN RAILROAD SHOPS

COMPRESSED air, which was used before electricity as a transmitter of power, is used in practically every railroad shop in the country, and, besides being used, it is also much abused at many of these points. Compressed air has the possible advantage over electricity in that means of utilizing it can be manufactured cheaply and easily. It is largely owing to this fact that it has been developed for railroad shop and yard work. It has the same disadvantage, however, as using a cheap but inefficient motor: The first cost is low, but the consumption of power is high. This might not at first be thought a serious consideration, but a check of several shop power plants shows that, not deducting for the exhaust steam, the shop air compressor consumed over 38 per cent. of all the steam generated by the shop power plant. This is due to several causes:

1.—The use of compressed air has been developed for various classes of shops, so that each individual shop, round house, and yard that makes up a group of railroad shops has its air lines and air tools.

2.—Unlike an electric transmission system a compressed air system can have a large number of leaks without causing immediate trouble other than an increased load on the air compressor. Even with careful supervision over the pipe lines there are always leaky valves developing, valves carelessly left partially open, or leaky air hose left with the pressure on it, while the compressor

runs on 24 hours in the day, compressing air to be wasted.

3.—As shop air lines are constantly being extended, it is not at all unusual for the feeders to be outgrown. This is a frequent cause of complaint, the complaint usually being that the compressor is too small, whereas, in this case, the compressor is not to blame. In planning a compressed air system, it is most important to get the mains and the reservoirs large enough not only to take care of the present, but to provide for future growth.

4.—As a usual thing, the smaller shops are dependent on one air compressor alone, which require that this compressor run 24 hours in the day and 365 days in the year. The result is that the engineer postpones any heavy repairs on the air compressor as long as he possibly can with a corresponding increase in the coal bill for which the air compressor is often not suspected. All in all, the air compressor and the compressed air equipment are very important and useful parts of a shop's equipment, but unless great care is taken they are much less efficient than they should be.

Steam and Electric Drive

Where a steam plant is necessary, regardless of whether a steam-driven compressor is installed or not, especially when the greater part of the exhaust steam is needed for heating during a portion of the year, and further when a steam-driven compressor can be installed in the power plant, and operated without the need of an additional engineer, an electrically-driven compressor cannot show much, if any, economy over the steam-driven machine. The advantage of the electrically-driven compressor is that it can be located near the point where the air is to be used, consequently long pipe lines can be avoided. With the electric compressor, as well as with the steam-driven compressor, a certain amount of power is consumed whenever the machine is running idle. A recent check of a motor-driven, two-stage compressor of about 500 cubic feet per minute capacity showed that the electrical energy used, while the equipment was running unloaded, was 17 per cent. of the amount used when compressing air to 110 pounds pressure. This loss may be avoided, especially with the smaller sized compressor, by installing an automatic starter for the motor, controlled by a pressure regulator. The advisability of such an installation depends largely on whether there are fairly long periods when the compressor may be shut down if equipped in this manner. If the compressor is required to start every few minutes, it would be more advisable to install an unloading device on the compressor and permit it to run constantly at full speed.

With a plant using one or more electrically-driven compressors, the question of whether the equipment shall be located at one point or distributed at two or more points depends on the first cost of the installation, the cost of transmitting the air and the electricity to the

desired points, the diversity of the load and the cost of attendance. As these items vary for each plant considered, it is impossible to lay down a definite rule. In the case of yards located at considerable distances from the steam power plant, it would be cheaper to transmit the electricity to the desired point than to transmit compressed air with the same percentage of loss. On the other hand, with a fairly compact shop plant, the additional cost of a pipe line designed to transmit the air efficiently from one point would be counterbalanced by the advantage of having all of the compressor equipment under one supervision. The importance of keeping all unused air lines shut off and of keeping all lines in first class condition may be emphasized by taking a concrete example.

Air Lines Maintenance

Assume that air compressed to 100 pounds pressure at a certain shop is costing four cents per thousand cubic feet of free air. A hole 1-16 inch in diameter in the pipe line would permit a leak of 6.45 cubic feet of air per minute, which would cost 37 cents per day of 24 hours, or \$135 per year. The following figures are the results of a test for air leakage, which was run at the shop and terminal plant of a railroad entering Chicago. At the time the test was run there were no machines in operation, therefore, the total leakage was due to leaks in the air line. This line was originally installed about 25 years ago, but has been continually repaired and added to since then. After the system was filled to a gauge pressure of 100 pounds per square inch, the compressor was stopped. When the gauge pressure had reached 40 pounds the time was noted. The calculations showed a leakage of 9.446 cubic feet of free air in 55 minutes, or 171.7 cubic feet per minute. The steam used per cubic foot of free air was shown by a previous test to be .1306 pounds, and the steam used in pumping leaking air amounted to 1.344 pounds per hour. The totals were:

Cost per hour of leaks	\$ 0.224
Cost per day (24 hours)	5.38
Cost per month	161.40
Cost per year	1936.80

Add 10 per cent. for machine leaks when shop is in full operation, the amount is \$2,905.20.—From a committee report. Association of Railway Electrical Engineers, Chicago.



A DEPARTMENT of glass technology at the University of Sheffield has been organized with the financial support of the Advisory Committee of the Privy Council for Industrial Research, of the Ministry of Munitions, and of the glass manufacturers of South Yorkshire. An actual glass factory will be established, in which operations will be done on a large, semi-commercial scale. The model factory will be equipped with pot furnaces and a small tank furnace and a series of experimental furnaces, including a number of electrically-heated ones and some heated by gas.

PROGRESS IN NEW EQUIPMENT

A Record of New and Improved Machinery and Accessories for the Machine, Pattern, Boiler and Blacksmith Shops, Planing Mill, Foundry and Power Plant

RAPID PRODUCTION SHELL LATHE

A RECENT addition to the ranks of shell making equipment is the machine shown in the accompanying illustration, which, while resembling in general appearance a single purpose machine, is so designed that it can be adapted to almost all of the numerous operations required on a shell. The bed is of high grade iron, 18 in. wide constructed to provide the maximum rigidity under the heaviest strains. The headstock is composed of two separate housings firmly bolted to the bed. The front bearing has a diameter of 9½-in. and a length of 7-in., while the rear one is 6-in. dia. and 7-in. long. These bearings are of high-grade babbit and are amply provided with suitable oiling devices. The spindle is of semi-steel and forms the outer portion of the air operated chuck; the split collet being located in the nose of the spindle, and the operating cylinder at the rear. With the chuck contained in the spindle and the exceptionally large bearings, any excess overhang is eliminated, thus permitting heavier cuts and greater stability.

The driving pulley is 21 inches in diameter, 8-inch face and fitted with a heavy bronze bushing with efficient oiling facilities. The clutch is of the cone type fitted with wooden friction blocks operated on the inner surface of the pulley rim. This clutch is controlled by air with the same movement that operates the chuck, but special pro-

vision is provided to allow for any variation in shell diameter, so that the driving power is always constant. The carriage is of semi-steel with a length of 24 inches and fitted with a special long

ing five opposed spindles arranged to permit of drilling holes with close centres in rails, and still retaining a powerful drive.

The range of adjustment on the three

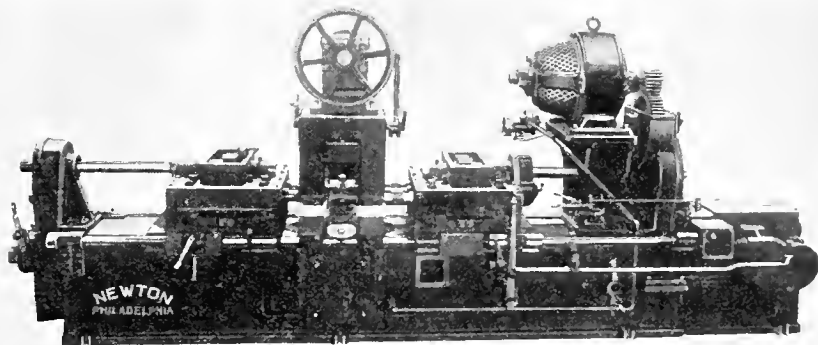

FIVE SPINDLE HORIZONTAL RAIL DRILLING MACHINE.

slide rest for the various tool blocks. The cut shows the machine tooled for waving and grooving but other tool blocks are provided for the various operations.

The Montreal General Tool Company are the designers and builders of these machines.



FIVE SPINDLE HORIZONTAL RAIL DRILLING MACHINE

THE accompanying illustration shows a newly developed drilling machine hav-

ing five opposed spindles arranged to permit of drilling holes with close centres in rails, and still retaining a powerful drive. The range of adjustment on the three spindle head is from 4 in. to 10½ in. between centres; the central spindle being fixed, the two outside spindles being adjustable from the operating side by means of a screw. On the two spindle head, the adjustment of the spindles range from 4 in. to 19 in. between centres. Either spindle on the two spindle head can be brought within 1 in. of the centre line of the central or fixed spindle on the three spindle head, thus providing a possibility of drilling holes within 1 in. centre distance.

Maximum distance between ends of spindles is 26 in., length of feed motion to each spindle 12 in. which will permit of removing a full length drill without disturbing the setting of the rail. Spindle gears are all of heat treated alloy steel, the various other parts being made of material best suited for the purpose.

Spindle saddles have full bearing on the base with strap and taper shoes, to compensate for wear, and are operated from a common pair of feed screws with right and left hand threads so that the right and left hand operate simultaneously.

Spindle heads have four changes of feed with rapid power traverse in both directions. Saddles are supplied with adjustable automatic stop to the feed motion with rapid power return having a safety limit to prevent jamming at either end of the saddle movement.

Machine has an adjustable elevating table to take care of the different size rails and is provided with an air controlled clamp, and is driven by a 15 h.p. motor having a speed range of 100 to 1200 R.P.M. The Newton Machine Tool Works, Philadelphia, are the builders of this machine.

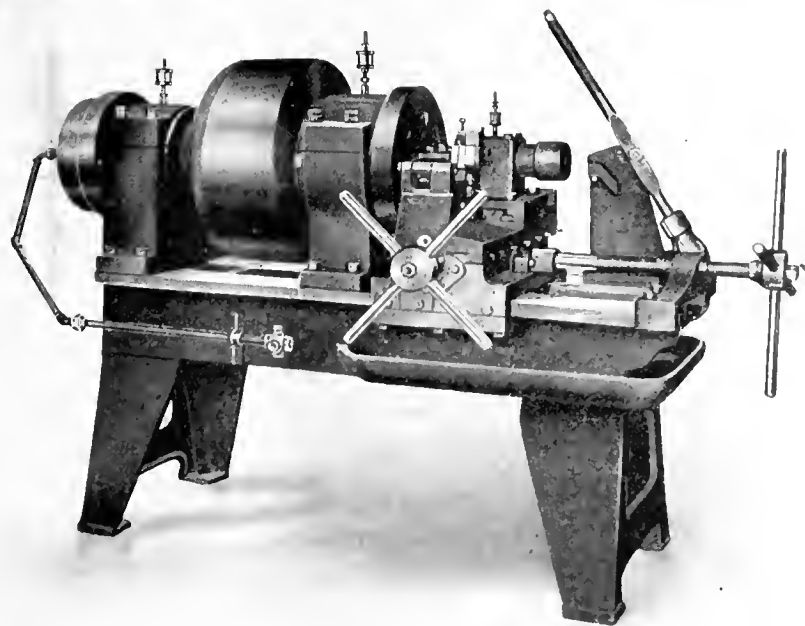

RAPID PRODUCTION SHELL LATHE.

LARGE ELECTRIC MOTOR

MODERN developments in electrical power equipment are aptly illustrated by the accompanying photograph of what is said to be both the largest and most

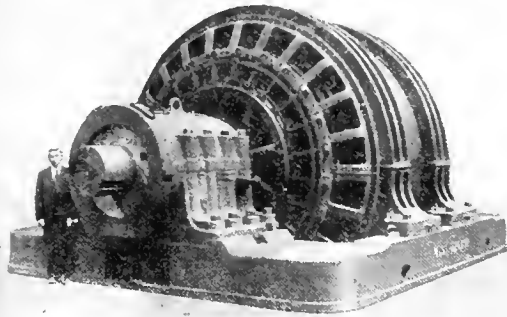

LARGE ELECTRIC MOTOR.

powerful electric motor ever built. The engraving shows it in the shops of the builders, the Westinghouse Electric & Mfg. Co., East Pittsburgh, Pa. It is designed for driving a two-high 35 in. reversing blooming mill which reverses for every pass, i.e. every time metal goes through the rolls.

The horse power developed is 15,000 and reversals can be made from full speed to full speed in about 2 seconds, 19 or 20 passes being made in 2 minutes under regular working conditions. The total weight of the complete motor is over 250 tons, the rotating part alone weighing 100 tons. The overall height is 20 ft., while the shaft diameter exceeds 24 ins.

FEEDING FIXTURE FOR DIE FORMING MACHINE

A UNIVERSAL pivoted feeding mechanism is illustrated herewith which has been developed by the makers of the Anderson die forming machine for facilitating the working of that machine on which it is shown in position. This fixture provides complete control of the die while being operated on by the cutter.

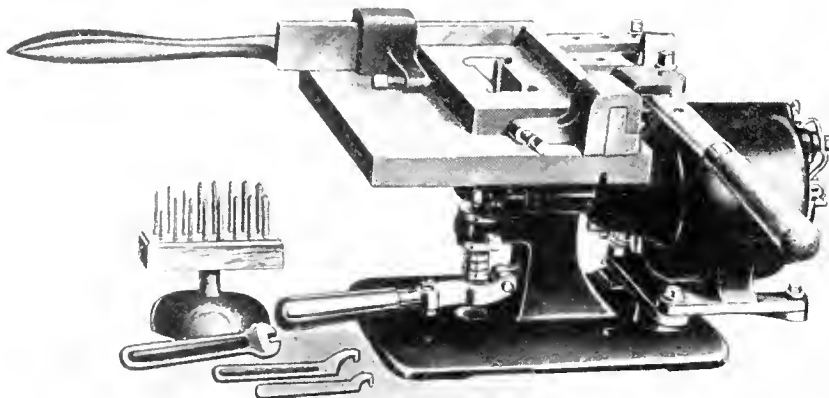

FIXTURE FOR FEEDING WORK ON DIE-FORMING MACHINE.

The die rests upon the table or platen, and is seened to an angle bracket by a pair of adjustable dogs or clamps, the bracket also resting on the platen, and being pivotally connected to a lever located at the rear. This lever has a series of holes placed about an inch apart, which allow the pivotal point to be conveniently located with regard to the necessary movement of the die around the cutter. This lever is fulcrumed on an adjustable arm attached to one edge of the platen, so that a combined adjustment of the lever and arm enable any portion of the die to be fed or guided so as to finish practically any outline without the operator touching the die with his hands.

When ordinary hand-feeding is desired, the fixture can be removed in a few seconds. It is now furnished as regular equipment by the Anderson Die Machine Co., Bridgeport, Conn.

PROTECTION-EDGE LAMINATED BELTING

BELTS on a planing machine are shifted from pulley to pulley every minute, sometimes every few seconds. There is therefore great wear on the edges, due to the friction of the belt forks, and the edges may be worn out while the centre of the belt is still in good condition. The result is that extensive repairs are required, involving delay and expense. To prevent this occurrence, John Tullis & Son, St. Ann's Leather Works, Glasgow, Scotland, have just introduced a protection-edge laminated belt, in which a special wearing piece is introduced on each edge. The belt itself, as per illustration, is made of laminae, 1 1/2 in. by 3-16 in., set on edge and sewn right through from edge to edge of the belt, the stitches lying on the neutral axis. The outer lamina on each side is hollowed on its

outer face, as shown, and the protection strip is laid in this hollow. This strip is originally 1 in. wide by 3-16 in. thick, and it is laid against the edge of the belt like the flange against the web of an I beam. The stitches pass first through the protection strip, then through all the laminae, and finally through the second protection strip, binding them all firmly together. When the sewing is complete the protection

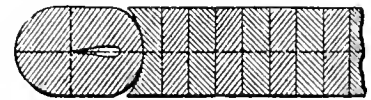

PROTECTION-EDGE LAMINATED BELTING.

strip is bent into U-form, as shown, and the two limbs of the U are sewn tightly together, a layer of cement being interposed between them. The protection strip thus becomes flush with both surfaces of the belt, and its outer edge is finally rounded off.

We understand that the belt answers immediately to the touch of the belt-fork and changes pulleys instantly, effecting a marked saving of time. In a recent trial a saving of nine hours per week was registered. As there is no cross-joint, since the joints in the various laminae occur at different places, there is no jolt or jar as the belt passes over the pulley.

MACHINIST'S SCREW DRIVER

A MACHINIST'S screw driver of robust construction has been put on the market by the Peck, Stow & Wilcox Co., Cleveland, O., a feature of which is a special square shank which permits the use of a wrench in turning heavy screws,



SOLID BAR MACHINISTS' SCREWDRIVER

enabling sufficient pressure to be brought to move the most stubborn screw.

This No. 1 size screw driver, marketed under the name of Pexto, is of "Solbar" construction, a solid bar of steel forming both shank and handle, and will withstand rough usage under all conditions.

Marvels of Creation.—A Scotch preacher had been abroad and when he came back he was preaching to his congregation on the marvels he had seen.

He wound up with this: "And the same Creator who made the vast ocean, made the dewdrop. The same Creator who made the mountains made the pebble. Yes, and that same Creator who made me made a daisy!"

Europe has about three and one-half times the telegraph traffic, nearly twice the first-class mail traffic, but only two-thirds the telephone traffic of the United States.

The MacLean Publishing Company

LIMITED

(ESTABLISHED 1888)

JOHN BAYNE MACLEAN President
H. T. HUNTER Vice-President
H. V. TYRRELL General Manager

PUBLISHERS OF

CANADIAN MACHINERY AND MANUFACTURING NEWS

A weekly newspaper devoted to the machinery and manufacturing interests.

PETER BAIN, M.E., Editor. B. G. NEWTON, Manager.

Associate Editors.

A. G. WEBSTER, J. M. WILSON, J. H. RODGERS.

Office of Publication, 143-153 University Avenue, Toronto, Ont.

Vol. XVII. FEBRUARY 15, 1917 No 7.

FUTURE ASPECTS OF SKILLED LABOR.

ONE of the principal handicaps which manufacturers are likely to encounter in this country, in the generally expected struggle for after-war trade, will be the obtaining of a supply of suitably trained labor. References to the lack of graduate apprentices recur at increasingly frequent intervals, generally accompanied by expressions of disappointment regarding the incompetence of such help as offers itself where trained journeymen were formerly available. Observers, both in Britain and America are noting closely the present tendencies of the situation, and where possible are exerting personal influence to the end that the employee's interests in obtaining a proper training are too closely identified with the employer's to permit the latter to ignore the facts of the case indefinitely.

A few mechanics are born, some are trained, but a large proportion are the creatures of circumstances, who started in a machine shop as boys glad to get rid of school studies and brain work of any description. Perhaps the machine shop was the only local opportunity; had it been a packing-house or a cheese factory, they would have started there for just the same reasons. Such youths seldom remain long enough or work seriously enough to imbibe any ideas of the trade's requirements; they may ultimately manage to read a micrometer and yet be unable to work a problem in decimal fractions, and no one cares, at the time. In after years the same youth may make costly errors in his work through careless reading of dimensions on drawings while his employer anathematizes machinists generally.

These conditions have been common in the past—most of our readers are probably able to recall such individuals and occurrences—and all of them have doubtless agreed that when all was said and done, the employers have themselves to blame, because they don't want to spend their own time or money training help for the ultimate benefit of other firms, and when the majority of employers view the situation thus, no remedy seems applicable.

At the present moment, too much importance is attached to the seeming ease with which munition workers have adapted themselves to work altogether foreign to many of them. The success attending the employment of women operators in several instances has also helped in developing a deprecatory attitude toward the trade of the

machinist. Such views are, however, based on temporary conditions, and are more frequently off-hand and superficial rather than the mature verdict of extended observations.

Nothing but a return to ordinary commercial work will bring about the previous state of affairs. The repetitive feature of shell production will not be present, and the efforts of this country to build up a foreign trade will involve for some time a variety of manufacture, throughout the country generally, and in many shops in particular, which will create a real demand for the all-round machinist, and it is in their efforts to anticipate this demand that manufacturers, who are laying plans for the future, have opportunity for displaying a degree of prescience, indicative of their ability to play a larger part in the future upbuilding of our industries.

Very few of our firms are in a position to operate training schools for apprentices, and the feasibility of co-operation among employers is suggested thus by a writer in a contemporary: "Why not get together within the industry and organize what will be frankly trade schools, owned and operated by the manufacturers through the medium of stock companies where boys shall be offered opportunities that they cannot afford to pass by?" This remark is quoted without any disparagement of the work being done in technical schools; attendance at such institutions does not always mean that the student will join the ranks of skilled mechanics—frequently he is induced to leave and enter the employ of some firm which fails to realize that it is to his own and the industry's ultimate loss.

The equipment and instruction given in a jointly owned school could be of a varied yet thorough nature which while in line with the general requirements of the student's employers would insure his ability to tackle any work not absolutely specialized.

Out of the large number of present operators, quite a few bright individuals are available who might well form the nucleus of a later addition to the ranks of trained machinists, an asset of considerable value to the trade, employers, and nation.

THE PIG-IRON SITUATION

THE iron and steel market continues to be affected by the international situation and the steel trade in Canada is being influenced in sympathy with conditions in the United States. Prior to the severance of diplomatic relations between the United States and Germany, the market was tense and unsettled. However, as soon as the decision was announced the situation cleared, and notwithstanding the diplomatic break, the market exhibited considerable activity, particularly in pig-iron, with the result that prices advanced. The advance in prices of pig-iron will, of course, be reflected in finished materials. The coke situation is serious and deliveries are very bad, owing to the shortage of cars and motive power, although every effort is being made to bring about the much desired relief. A large number of United States Steel Corporation furnaces are out of blast, while those in Canada and the Buffalo, N.Y., district, which depend on Connelsville coke, are at least badly handicapped, some as a matter of fact being out of blast. There is consequently a serious shortage of pig-iron, with little prospect of relief in the meantime. While foundry iron is being quoted around \$35 to \$36 Valley and Buffalo furnaces, there is practically none to be had. At this price, pig-iron laid down at Toronto would be \$42.00 to \$43.00 per ton. Indications point to a more serious shortage of pig-iron than has yet existed, and, should this condition arise, \$50.00 pig-iron in Toronto may be looked for.

BOILER TUBES.

Size.	Seamless	Lap-welded
1 in.	\$22 00
1 1/4 in.	25 00
1 1/2 in.	29 00	24 00
1 3/4 in.	30 00	22 50
2 in.	33 00	20 00
2 1/2 in.	35 50	29 50
3 in.	46 00	34 50
3 1/4 in.	41 00
3 1/2 in.	53 00	44 00
4 in.	63 00	55 00

Prices per 100 feet, Montreal and Toronto.

OILS AND COMPOUNDS.

Castor oil, per lb.	25
Royalite, per gal., bulk	12
Machine oil, per gal.	25 1/2
Black oil, per gal.	12 1/2
Cylinder oil, Capital	45 1/2
Cylinder oil, Acme	39 1/2
Standard cutting compound, per lb.	0.6
Lard oil, per gal.	1 45
Union thread cutting oil antiseptic	68
Acme cutting oil, antiseptic	37 1/2
Imperial quenching oil	39 1/2
Petroleum fuel oil	12

BELTING—NO. 1 OAK TANNED.

Extra heavy, single and double	30-5%
Standard	40%
Cut leather lacing, No. 1.	\$1 55
Leather in sides	1 35

TAPES.

Chesterman Metallic, 50 ft.	\$2 00
Lufkin Metallic, 603, 50 ft.	2 00
Admiral Steel Tape, 50 ft.	2 75
Admiral Steel Tape, 100 ft.	4 45
Major Jun. Steel Tape, 50 ft.	3 50
Rival Steel Tape, 50 ft.	2 75
Rival Steel Tape, 100 ft.	4 45
Reliable Jun. Steel Tape, 50 ft.	3 50

WASTE.

White	Cents per lb.
XXX Extra	20
Peerless	20
Grand	19
Superior	19
X L C R	18
Atlas	18
X Empire	18
Ideal	17
X press	16

COLORED.

Lion	14 1/2
Standard	13
No. 1	13
Popular	11 1/4
Keen	10 1/2

WOOL PACKING.

Arrow	25
Axle	20
Anvil	15
Anchor	11

WASHED WIPERS.

Select White	12
Mixed colored	10
Dark colored	09

This list subject to trade discount for quantity.

RUBBER BELTING.

Standard	50%
Best grades	30%

ANODES.

Nickel	.50 to .54
Cobalt	1.75 to 2.00
Copper	.44 to .46
Tin	.49 to .56
Zinc	.23 to .25

Prices Per Lb.

COPPER SHEETS.

Montreal		Toronto	
Bars, 1/2 to 2 in.	\$46 00	\$46 00	
Plain sheets, 14 oz., 14x28 in., 14x60 in.	45 00	45 00	
Copper sheet, tinned, 14x60, 14 oz.	54 00	54 00	
Copper sheet, planished, 14x60 base.	57 00	57 00	
Braziers' in sheets, 6x4 base	46 50	46 50	

BRASS.

Brass rods, base 1/2 in to 1 in rd.	0 55
Brass sheets, 8 in. wide, 20 oz.	0 60
Brass tubing, seamless.	0 55
Copper tubing, seamless.	0 55

PLATING SUPPLIES.

Polishing wheels, felt.	2 10
Polishing wheels, bull-neck	1 35
Emery in bags, American	06
Pumice, ground	04
Emery glue	15 to 20
Tripoli composition	04 to 06
Crocus composition	07 to 08
Emery composition	08 to 09
Rouge, silver	35 to 50
Rouge, powder	30 to 35

Prices Per Lb.

LEAD SHEETS.

Montreal		Toronto	
Sheets, 3 lbs. sq. ft.	\$12 00	\$12 50	

Sheets, 3 1/2 lbs. sq. ft.	11 75	12 25
Sheets, 4 to 6 lbs. sq. ft.	11 50	12 00
Cut sheets, 1/2c per lb. extra.		
Cut sheets to size, 1c per lb. extra.		

PLATING CHEMICALS.

Acid, boracic	\$.15
Acid, hydrochloric	.06
Acid, hydrofluoric	.14 1/2
Acid, nitric	.10
Acid, sulphuric	.05
Ammonia, aqua	.08
Ammonium carbonate	.15
Ammonium chloride	.11
Ammonium hydrosulphuret	.40
Ammonium sulphate	.07
Arsenic, white	.12
Copper, carbonate, anhy.	.25
Copper, sulphate	.17
Cobalt sulphate	.50
Iron perchloride	.20
Lead acetate	.16
Nickel ammonium sulphate	.12
Nickel carbonate	.25
Nickel sulphate	.15
Potassium carbonate	.75
Potassium sulphide (substitute)	.20
Silver chloride (per oz.)	.65
Silver nitrate (per oz.)	.55
Sodium bisulphite	.10
Sodium carbonate crystals	.05
Sodium cyanide, 127-130%	.41
Sodium hydrate	.04
Sodium hyposulphite, per 100 lbs.	5.00
Sodium phosphate	.14
Tin chloride	.00
Zinc chloride	.00
Zinc sulphate	.09

Prices Per Lb. Unless Otherwise Stated.

The General Market Condition and Tendency

ALTHOUGH there has been no further development in the strained relations between the United States and Germany, the possibility of war between these countries and its effect upon Canadian trade is still the main topic of discussion, particularly in manufacturing circles. Whether importations into Canada would be affected to any appreciable extent is a matter of conjecture, yet it is believed in some quarters that the situation would not be greatly changed. The severe weather has helped materially in further restricting the movement of cars on the railways and the situation is more acute than ever. In this district foundries are closing down owing to shortage of coke, and for the same reason furnaces are operating at reduced capacity. This, in turn, is adversely affecting mill operations, resulting in reduced output of steel. In this respect the situation is particularly serious, as the production of munitions is liable to be affected unless conditions improve at an early date. Steel prices continue very firm, advances in tubes, bolts and nuts having been registered during the week, while higher prices on other steel products may be looked for in the near future. On all raw material, the general trend of prices is upward, and this will be reflected in prices of finished goods. Prices of ingot metals have been well maintained, with advances in lead and antimony. The situation in the metal markets, however, will be more or less unsettled until the relations between the United States and Germany are definitely settled one way or another. Scrap prices are firm, with an upward tendency for most metals. Prices of machine tools continue to advance steadily. Business has, however, been quiet, although outlook is favorable.

Montreal, Que., Feb. 12.—Industrial conditions are now at a stage when it is next to impossible to define the actual situation. Actual hostilities between the United States and Germany are still a matter of the future, but should it so hap-

pen that circumstances are unfortunate enough to bring about war the effect on Canada may call for strict measures to cope with the changed conditions. The severity of the weather and traffic congestion on the railroads is seriously af-

fecting the general situation, manufacturers experiencing great difficulty in obtaining much needed material.

Steel.

Owing to the dependency of Canada on American products, early developments may create a serious situation in this country and steel production here would require to be stimulated to meet the existing requirements. The demand for steel forging billets has been so insistent that Pittsburg quotations have advanced \$5 per ton, the price being now \$85 per ton. Production has been somewhat curtailed owing to lack of ferro-alloys, the domestic supply being scarce and shipments from abroad being delayed through shipping regulations. Ferro-silicon is now quoted at \$200 and ferro-manganese as high as \$250 per ton. Recent demand for plates has been light, but this is largely due to the fact that many mills will not take business owing to their heavy future bookings. Early future conditions may demand increased production of this class of steel, with the result that other output must suffer. The demand for wire products has not increased to any great extent, but the spring requirements, together with pending developments may create increased demand and also stiffer prices. Inquiries for black sheets continue to tax the productive powers of the mills and a recent advance of \$5 per ton has been placed on Pittsburg quotations, the current price being \$5.25 per hundred. The local situation is much affected by freight congestion, weather conditions making it very difficult to receive delivery of material. Should a crisis be reached on the other side of the line deal-

ers here anticipate a much more serious condition than that at present. Prices here are generally firm, those affected this week being plates, which show an advance of about 10 per cent. Plates $\frac{1}{4}$ to $\frac{1}{2}$ inch are \$6; heads, \$6.35, and tank plates 3-16 inch, \$6.10 per hundred. Other quotations are firm with a higher undertone.

Metals.

General conditions continue very firm with quotations stronger, the feature of the week being the further advance of antimony. The tension of the United States political situation, together with transportation difficulties, tends to maintain a strong but unsettled market. Copper is firm and higher. Tin is strong as a result of increased marine risks. Spelter is steady but uncertain. Lead is higher and scarce. Antimony is very strong, but early delivery may develop a weaker tendency. Aluminum is very firm but unchanged.

Copper.—The ever-present possibility of uncertain developments tends to keep the market in a nervous and unsettled condition. Circumstances at the present time are not a reliable guide to buyers of metal, as international relations are such that the market might move forward or backward by hourly developments. Another factor that tends to add strength to the situation is the extreme difficulty in getting delivery. Many consumers of copper are forced to obtain shipments by express. Prices continue to advance both in London and New York, the latter quoting the nominal price of $33\frac{1}{2}$ c. for prime lake, $34\frac{1}{2}$ c. for electrolytic, and $30\frac{1}{2}$ c. for castings; these quotations show an advance of $1\frac{1}{2}$ c. on the two former and one cent on castings. Dealers here are quoting last week's prices, but anticipate an early advance.

Tin.—Continued activity on the part of enemy submarines and the consequent danger to shipment of metal from abroad is maintaining a very strong market, which is reflected in the further advance of prices. Buyers in many instances are compelled to take the risk of arrival, and this makes consumers rather cautious in contracting for requirements. English markets are higher and New York has advanced $3\frac{1}{2}$ c. over last week, the nominal quotation being 55c. per lb. Prices here are unchanged and nominal at 56c. per lb.

Spelter.—The lull that followed the activity of a couple of weeks ago has been partly dispelled and business is slightly brisker than last week, but conditions are such that a movement on the part of buyers would strengthen the market, while an adverse effect would result should sellers show an active interest. The prevailing strength is more related to the uncertainty of early future possibilities than that of actual present conditions. New York is one cent stronger than last week, the quotation being $105\frac{1}{2}$ c. per lb. The market here is firm at 15c.

Lead.—Railroad difficulties and uncertain delivery have resulted in further strength in the lead situation. Little relief is expected for some time. Added to this, the apparent scarcity has had much to do with recent advances. The current

trust price is $8\frac{1}{2}$ c., and independents are asking $9\frac{1}{4}$ c., these quotations being an advance over last week of $\frac{1}{2}$ c. and $\frac{3}{4}$ c. respectively. The local situation is active at last week's quotation of 11c., but with a stronger undertone.

Antimony.—Following a brisk inquiry for spot metal on the part of certain munition manufacturers the price of antimony was subjected to another sharp advance. Metal for immediate delivery is extremely hard to get, but the supply in transit is expected to relieve the tension of the situation. The time of delivery, however, is so uncertain that the present market will likely be maintained until sellers become active, and it is anticipated that the near future might see a decline to a lower level. Reports from New York show an advance of 10c. over prices quoted last week, the current quotation being 35c. per lb. Dealers here report a heavy demand, on an advance of 12c. over last week, the price this week being 37c. per lb.

Machine Tools and Supplies.

The volume of business is not large,

CANADIAN GOVERNMENT PURCHASING COMMISSION

The following gentlemen constitute the Commission appointed to make all purchases under the Dominion \$100,000,000 war appropriation:—George F. Galt, Winnipeg; Hormidas Laporte, Montreal; A. E. Kemp, Toronto. Thomas Hilliard is secretary, and the Commission headquarters are at Ottawa.

but the inquiry for single tools and small lots is sufficient to maintain a fair degree of activity in Canadian tool circles. American manufacturers and those plants recently employed on munitions are not taking the same interest in this field that was shown about a month ago. This is probably due to the unsettled conditions following the action of the U.S. government in breaking off relations with Germany. Should the situation become more critical and the republic be involved in hostilities, the manufacture of shells for possible needs may stimulate the machine tool industry to the point where it would be increasingly difficult to secure delivery of machinery to Canadian users. This would undoubtedly reflect favorably on manufacturers in this country as the demand for home machinery would be greatly increased.

Scrap

The tendency of old metal is upward, but the market is somewhat disturbed owing to general conditions. Large consumers are light buyers, not covering their requirements for extended periods. New York quotations on copper wire and brass clippings are higher, also on composition turnings, but local dealers report unchanged conditions and prices.

Toronto, Ont., Feb. 15.—The shortage of coal dominates the industrial situation and there is no apparent relief in sight, notwithstanding the great efforts that have been made to improve conditions. A serious tie-up threatens our factories to say nothing of the inconvenience to the public at large. The shortage of coke is also serious and promises to develop into an actual famine if drastic steps are not taken at once to relieve the situation. The shortage is seriously restricting the operations of foundries and furnaces, which in the latter case will be reflected in a decreased production of steel.

Steel

Steel plants, in this section of the country particularly, are feeling the shortage of pig iron more than ever and the increase in cost of this material will be reflected in finished and semi-finished steel. The market continues very strong with a decided upward tendency in prices. The advance in tubes, in effect this week, is a direct result of conditions in the U.S. market, while higher prices on other materials may be looked for in the near future. The market is still overshadowed by the possibility of war being declared between United States and Germany. Consumers are anxious to get delivery on as much material as possible in case the U.S. Government should place orders for steel for war purposes. The demand on the mills for plates from shipyards is very heavy, the output being sold for the balance of the year. Prices of plates are very firm and will doubtless advance in the near future. Lapweld boiler tubes have advanced 10 per cent. All makers of iron and steel tubes are practically sold up for all of this year. An advance in bolts and nuts of approximately $6\frac{1}{2}$ per cent. is now in effect.

Prices on black sheets are very firm with an upward tendency. The demand is heavier than the mills can take care of, as production is being restricted because of the difficulty in getting fuel and raw materials. Sheet bars continue high in price with a possibility of further advances. On account of the situation in black sheets, prices of galvanized materials are holding firm.

The steel market in the U.S. is steady and firm notwithstanding the unsettled international situation. Whatever may result from the present strained relations between the United States and Germany there is little doubt but that steel prices will advance. Production is being curtailed on account of the transportation difficulties and cold weather. The coke shortage is more acute, shipments of Connellsville coke being only about half of the amount required. Chicago warehouse prices have advanced and quotations are now as follows. Steel bars 3.90c; steel bars 2-in. and up, 4.40c; structural shapes 4c, and plates 4.75c. Pittsburg steel bars are unchanged at 3.25c, and shapes at 3.25c, but tank plates are higher at 4.75c. The unfilled orders of the U.S. Steel Corporation on Jan. 31 were 11,474,504 tons.

being a decrease of 73,232 tons compared with Dec. 31.

Pig Iron

Production of pig iron continues to decline owing to the coke shortage which is getting more acute. The cold weather at the ovens has curtailed operations and the production of coke has been practically cut in half. Railway conditions are no better, seriously restricting the movement of coke to the furnaces and thereby curtailing output. Many foundries are working at reduced capacity and in some cases have shut down until the situation improves. Some pig iron is being imported from the United States, although not nearly as much as is required. Price continues high, being about \$35 Buffalo or Valley furnace, which would be around \$43 laid down in Toronto. Canadian pig iron continues off the market and no quotations are being issued.

Scrap

Prices of old material are generally firm but there have been no important changes made during the week. The curtailment of pig iron production is causing the mills to use more scrap; this will tend to advance prices. There is a fair demand for steel turnings and borings but supplies are coming to hand in good volume. All copper and brass scraps are firm in sympathy with new metal.

Machine Tools

There is no change in the situation in the machine tool market, although the outlook is at the present time rather unsettled on account of international complications. Prices of machine tools in the U.S. continue to advance, affecting several types of machines. Power hammers have advanced 10 per cent; planers, boring mills, and radial drills are from 10 to 20 per cent. higher, while drills are 5 per cent. higher. Deliveries are slower particularly on milling machines, shapers and lathes.

Supplies

Business continues active and prices are still advancing owing to the increase in cost of practically all raw materials. The leather market is very firm and higher prices on belting are looked for. Cut lace leather and side lace leather have advanced about 5c per pound, being now quoted at \$1.60 and \$1.40 respectively. Stillson and Trimo wrenches have advanced 10 per cent. Gasoline is very firm but unchanged meantime, although the falling off in the production of crude oil and continued heavy consumption of gasoline may result in higher prices. Coal oil has however advanced 1c a gallon.

Metals

The possibility of the breach widening between the U.S. and Germany has been reflected in the metal markets during the week. The likelihood of increased demand for war metals has had a tendency to hold prices firm, but they are in many cases entirely nominal. Lead and antimony have advanced, otherwise prices are unchanged. Business

(Continued on page 144.)

Enlarged Canadian Trade Intelligence Service

Under the arrangement made by the Minister of Trade and Commerce with Sir Edward Grey in July, 1912, the Department of Trade and Commerce, Ottawa, is able to present the following list of the more important British Consulates whose officers have been instructed by the Foreign Office to answer inquiries from and give information to Canadians who wish to consult them in reference to trade matters.

BRAZIL—Bahia, British Consul. Rio de Janeiro, British Consul General.	NETHERLANDS—Amsterdam, British Consul.
CHILE—Valparaiso, British Consul General.	PANAMA—Colon, British Consul. Panama, British Vice-Consul.
COLOMBIA—Bogota, British Consul General.	PERU—Lima, British Vice-Consul.
ECUADOR—Quito, British Consul General. Guayaquil, British Consul.	PORTUGAL—Lisbon, British Consul.
EGYPT—Alexandria, British Consul General.	RUSSIA—Moscow, British Consul General. Petrograd, British Consul. Vladivostok, British Consul. Odessa, British Consul General.
FRANCE—Havre, British Consul General. Marseilles, British Consul General.	SPAIN—Barcelona, British Consul General. Madrid, British Consul.
INDIA—Calcutta, Director General of Commercial Intelligence.	SWEDEN—Stockholm, British Consul.
ITALY—Genoa, British Consul General. Milan, British Consul.	SWITZERLAND—Geneva, British Consul.
MEXICO—Mexico, British Consul General.	URUGUAY—Monte Video, British Vice-Consul.
	VENEZUELA—Caracas, British Vice-Consul.

Canadian Commercial Intelligence Service

The Department of Trade and Commerce invites correspondence from Canadian exporters or importers upon all trade matters. Canadian Trade Commissioners and Commercial Agents should be kept supplied with catalogues, price lists, discount rates, etc., and the names and addresses of trade representatives by Canadian exporters. Catalogues should state whether prices are at factory point, f.o.b. at port of shipment, or, which is preferable, c.i.f. at foreign port.

CANADIAN TRADE COMMISSIONERS.

ARGENTINE REPUBLIC—H. R. Poussette, Reconquista, No. 46, Buenos Aires. Cable address, Canadian.
AUSTRALIA—D. H. Ross, Stock Exchange Building, Melbourne. Cable address, Canadian.
BRITISH WEST INDIES—E. H. S. Flood, Bridgetown, Barbadoes, agent also for the Bermudas and British Guiana. Cable address, Canadian.
CHINA—J. W. Ross, 13 Nanking Road, Shanghai. Cable address, Cancona.
CUBA—Acting Trade Commissioner, Lonja del Comercio, Apartado 1290, Havana. Cable address, Cantracom.
FRANCE—Phillipe Roy, Commissioner General, 17 and 19 Boulevard des Capucines, Paris. Cable address, Stadacona.
JAPAN—G. B. Johnson, P. O. Box 109, Yokohama. Cable address, Canadian.
HOLLAND—Acting Trade Commissioner, Zuidblaak, 26, Rotterdam. Cable address, Watermill.
RUSSIA—C. F. Just, Canadian Government Commercial Agent, Alexandriyskaya Ploshch 9, Petrograd. L. D. Wilgress, Canadian Government Commercial Agent, Bukhgalza Ulitsa No. 4, Omsk, Siberia.
NEWFOUNDLAND—W. B. Nicholson, Bank of Montreal Building, Water Street, St. John's. Cable address, Canadian.
NEW ZEALAND—W. A. Reddie, Union Buildings, Customs Street, Auckland. Cable address, Canadian.
SOUTH AFRICA—W. J. Egan, Norwich Union Buildings, Cape Town. Cable address, Cantracom.
UNITED KINGDOM—Harrison Watson, 53 Basildon Street, London, E.C., England. Cable address, Sleighing, London. N. D. Johnston, Sun Building, Clare Street, Bristol. Cable address, Canadian. J. E. Ray, Central House, Birmingham. Cable address, Canadian. J. Forsyth Smith, 27-28 Pearl Building, East Parade, Leeds. Cable address, Canadian. P. A. C. Bickerike, Canada Chambers, 26 Spring Gardens, Manchester. Cable address, Cantracom. J. T. Lithgow, 87 Union Street, Glasgow, Scotland. Cable address, Cantracom.

SPECIAL TRADE COMMISSIONER—LUMBER

H. R. McMillan, visiting Europe, Africa, Australasia and the Orient.

CANADIAN COMMERCIAL AGENTS

AUSTRALIA—R. Millin, Exchange Building, Sydney, N.S.W.
BRITISH WEST INDIES—Edgar Tripp, Port of Spain, Trinidad. Cable address, Canadian. R. H. Curry, Nassau, Bahamas.
NORWAY AND DENMARK—C. E. Sontum Grubbeget N. 1 Christiania, Norway. Cable address, Sontum.

CANADIAN HIGH COMMISSIONER'S OFFICE

UNITED KINGDOM—W. L. Griffith, Secretary, 17 Victoria Street, London, S.W., England. Cable address, Dominion, London.

INDUSTRIAL ^A_N^D CONSTRUCTION NEWS

Establishment or Enlargement of Factories, Mills, Power Plants, Etc.; Construction of Railways, Bridges, Etc.; Municipal Undertakings; Mining News

ENGINEERING

St. Catharines, Ont.—The St. Catharines Brass Works, Ltd., is building a foundry.

Winnipeg, Man.—The Swift Canadian Co., are considering the erection of an abattoir, to cost \$3,000,000.

Pembroke, Ont.—The Pembroke Machinery Co., will at an early date erect a machine shop to cost \$12,000.

Vancouver, B.C.—John Coughlan & Sons, propose building a machine shop at an approximate cost of \$10,000.

Toronto, Ont.—The Wm. Davies Co. will erect a frame and iron bridge between storehouses at 521 Front street, at a cost of \$2,500.

Hull, Que.—The Hull Iron & Steel Foundries, Ltd., propose to make additions to its plant which it is reported will cost \$500,000.

Hamilton, Ont.—Construction work has been started on the erection of an addition to the plant of the Canadian Shovel & Tool Co.

Toronto, Ont.—The Deyo Macey Engine Co., Binghamton, N.Y., will establish a plant in Toronto for the manufacture of gas engines.

Sarnia, Ont.—Large additions will be made to the plant of the Mueller Mfg. Co., and a considerable quantity of new machinery will be installed.

Windsor, Ont.—Fire on Feb. 7 damaged the Kelsey Wheel Co.'s plant, the loss being estimated at \$5,000 which is fully covered by insurance.

Hamilton, Ont.—The Standard Underground Cable Co., are completing the construction of an extension to their plant which will cost about \$30,000.

Tecumseh, Ont.—The Eau Claire Waterworks Co., are in the market for two centrifugal pumps and motors. R. W. Code, Windsor, Ont., is the engineer.

Hamilton, Ont.—The Canadian-Diamond-Stephen Mfg. Co., Urbana, Ohio, is making preparations for the erection of a plant here for the manufacture of steam ejectors, etc.

Sherbrooke, Que.—Fire on Feb. 8, damaged the plant of the MacKinnon, Holmes Co., steel manufacturers, here, to the extent of about \$30,000. The loss is covered by insurance.

Port Arthur, Ont.—It is understood that the Port Arthur Pulp & Paper Co., will not build a mill here as was originally intended. It is probable that the mill will be located in the Nipigon district.

Gravenhurst, Ont.—The foundry and machine shop of the E. Long Manufacturing Co. of this town was destroyed by fire on Feb. 6. The plant was valued

at about \$20,000, with insurance of \$10,000.

Amherstburg, Ont.—It is reported that the Semet-Solvay Co. may proceed with the construction of a chemical plant here. It is understood that G. S. Rutherford of Hutchinson, Kan., will be in charge of the work.

London, Ont.—The United Metal Products Co., recently formed by local capital has taken over the factory building formerly occupied by the Jose Caste Cigar Co. on King street and will manufacture munition parts.

Welland, Ont.—The Canadian Steel Foundries, Ltd., has commenced the erection of an addition to its plant which will double the present capacity. The total improvements now under way, including machinery, will cost \$500,000.

London, Ont.—The London & Port Stanley Railway Commission has decided to purchase a motor freight car at a cost of \$23,500, to assist in handling the increased traffic of the road. The purchase was recommended by General Manager J. E. Richards.

GENERAL MARKET CONDITIONS

(Continued from page 143.)

Business locally continues good and the outlook favorable.

Copper.—Although the position of copper continues to be a strong one the situation is unsettled in the U.S. owing to the accumulation of supplies at the seaboard and embargoes placed by many railways on account of congestion of traffic. Producers are sold up for the first half of this year and there is very little spot copper to be had. Prices continue nominal and unchanged at 38c per pound.

Tin.—The market is quiet but prices are unchanged and nominal. The market is dominated by the submarine situation and the fear that cargoes of tin may be lost is tending to hold prices firm. Local quotation unchanged at 58c per pound.

Spelter.—The market is quiet and unchanged with no particular feature to note; local price 13½c per pound.

Lead.—Local prices have advanced following the action of the "Trust" in quoting lead at 8.50c New York. The outside market however is still higher ranging from 8½c to 9¼c New York. Scarcity of supplies is understood to be the reason for the higher prices. Lead has advanced 1c locally and is quoted at 11c per pound.

Antimony.—Although antimony would not be affected by submarine operations, prices continue to advance, but are entirely nominal. Antimony has advanced 9c and is quoted at 35c per pound.

Aluminum.—The market is dull with quotations unchanged at 68c per pound.

London, Ont.—The London Smelting & Refining Co., have purchased the old power house of the London and Lake Erie Railway at Chelsea Green, London, and has converted this into a plant for the smelting and refining of metal under the management of Geo. Trudell.

Ottawa, Ont.—Hon Robert Rogers announced last Thursday that the Norton-Griffith contract for the St. John harbor works, had been cancelled and a new contract was being prepared and tenders would be called immediately and work carried on as expeditiously as possible.

Toronto, Ont.—British Forgings, Ltd., have taken out a permit for the second section of the foundation work for the factory they are to erect at the foot of Cherry street. The cost of the second part of the work is set at \$35,000, or \$10,000 above the first.

Toronto, Ont.—The City Architect has issued a permit for the erection of the first section and foundations of the new steel plant, which the Imperial Munitions Board are establishing in the Ashbridge's Bay district. The building and foundations are estimated to cost \$200,000.

Port Mann, B.C.—Work on the new car plant of the C.N.R. at Port Mann is progressing satisfactorily, and should be in operation by the end of March. The plant will turn out five cars daily and when finished will do much towards relieving the car shortage which has become a serious problem.

Niagara Falls, Ont.—The Hydro-Electric Power Commission are buying a large quantity of contractors' plant in connection with their Chippewa Creek development here, including rubber belting, motors, cement, conveyors, electric hoists, derricks, locomotive cranes, small jaw crushers, concrete mixers and machinery, etc.

Newcastle, N.B.—The New Brunswick Sulphite Fibre Co., have just secured incorporation under Dominion charter, with a capitalization of \$200,000. They have taken over the Millerton property and nearly all the necessary machinery for operating the pulp mill has been secured. The company expects to begin the manufacture of pulp in April.

London, Ont.—Beatty Bros. Ltd. of Fergus and London manufacturers of pumps, grain grinders, etc., have decided to locate their foundry at London in the Chelsea Green industrial district. This will be started immediately and will cost approximately \$30,000. This development is only the beginning of plans for London where it is expected, they will before long employ between three hundred and four hundred hands. A large site was given free of cost to

ELECTRIC MOTORS?

PHONE MOTOR DEPARTMENT

ADELAIDE 20

In Toronto and at all our branch warehouses we carry very complete stocks of Electric Motors, Dynamos and Portable Electric Tools of all kinds.

Just now we have large stock orders placed for 3-phase, 25-cycle Motors, and can in this way very often give you better deliveries than manufacturers themselves. We give special attention to all apparatus required in the nature of Electric Motor power, and can give you expert advice on all your Electrical Problems. Write us.

The A. R. WILLIAMS MACHINERY CO., Ltd.

64-66 Front Street West

TORONTO, CANADA

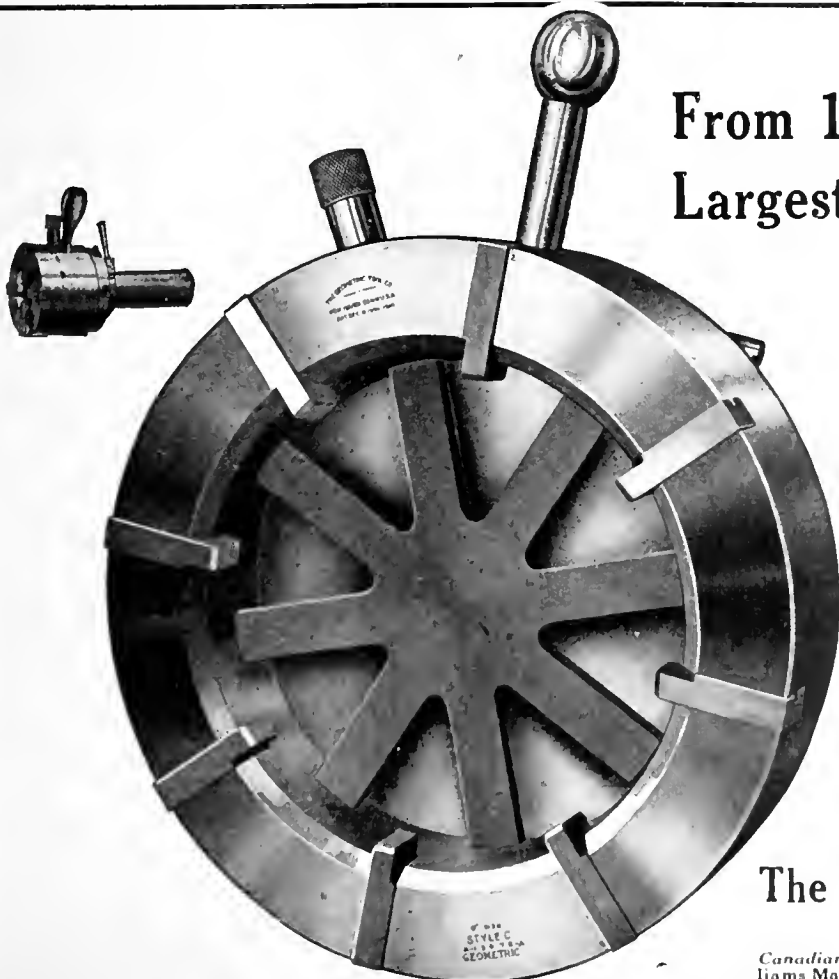

**From 1/16-Inch up to the
Largest Diameter Required**

GEOMETRIC

Self-opening Die Heads are in use on every make of Screw Machine. Rapid production and economy follow their installation. With the Geometrics there are no defective threads, and consequently no waste.

Let us send you our catalogue, which will describe to you the Geometric line of Screw-cutting Tools.

The Geometric Tool Company

NEW HAVEN, CONN., U.S.A.

Canadian Agents: Williams & Wilson, Montreal; The A.R. Williams Machinery Co., Ltd., Toronto, Winnipeg, St. John, N.B.

THE IRON WORKS
 Successors to **LIMITED**

Owen Sound Iron Works
 Owen Sound, Ont.
 Engineers
 Boiler-makers
 Founders
 Machinists

Tank Work
 Smoke Stacks,
 Grey Iron and
 Brass Castings,
 Special
 Machinery
 Made to
 Order

Davis-Bournonville Oxy-Acetylene Welding and Cutting Apparatus Leads the World

Over 2,400 plants in daily operation. Medal of Honor, Highest Award at Panama Exposition.

PORTABLE GENERATORS
 STATIONARY GENERATORS
 WELDING TORCHES
 CUTTING TORCHES
 REGULATORS
 HOSE
 CARBIDE
 WELDING RODS
 FLUX
 CARBONITE RODS
 GOGGLES
 CARBON REMOVERS
 PORTABLE TRUCKS
 COMPRESSED ACETYLENE

Price list and full particulars on request.

Carter Welding Co.
 9-11 Sheppard Street
 TORONTO, ONT.
 Phone Adelaide 2841
 Canadian Agents for
 The Davis-Bournonville Apparatus

Beatty Bros, through the Industrial Department.

Banff, B.C.—Dr. R. Harry Brett, of Banff, is one of the incorporators of a new company, capitalized at \$20,000, that will develop some of the natural resources of the Alberta mountain country. The Alberta Electro-Chemicals, Ltd., has just been given a charter which empowers it to manufacture, buy, and sell chemicals, minerals and mine and forest products, with Banff as its head office. It is understood that the purpose of the new company is to manufacture carbide at Kananaskis Falls, near Banff. Advantage will be taken of the hydro-electric plant at the Falls for power purposes.

Vancouver, B.C.—It is announced that a large floating drydock is to be built here. The structure will be a 16,000-ton double-section dock, capable of handling a boat of 18,000 tons, which is the measure of maximum requirements on the Pacific to-day. The company is the Vancouver Dry Docks, Ltd. A ship-repair and shipbuilding plant is a part of the plan decided upon. Contracts for construction and machinery are being let, and the company announces that it will have the dock in operation within a year. There will be subsidy aid from the Governments of both the Dominion of Canada and the Province of British Columbia, on the ground that the dock will be a commercial and naval asset.

MUNICIPAL

Strathroy, Ont.—The Town Council contemplate purchasing a motor driven turbine pump.

Wolseley, Sask.—The Town Council are considering an extension to the light and power plant, to cost \$9,000.

Strathroy, Ont.—Town Council has decided to purchase smoke helmets, cellular nozzles and other equipment for the fire department.

Toronto, Ont.—A bill will be submitted to the Provincial Legislature to empower the Board of Control to establish coal docks and storage at a total cost of \$2,000,000.

Preston, Ont.—The Preston Car & Coach by-law, whereby the town will be asked to guarantee \$75,000 worth of bonds, was put through and will go to the people on March 5th.

Preston, Ont.—The Town Council held a special session recently to consider the recommendation of the Board of Trade that a by-law be submitted to the ratepayers asking them to endorse a loan or a bond guarantee of \$75,000 to the Preston Car & Coach Co.

Warton, Ont.—The Council is considering a proposition for electric light and power from the Hydro-Electric Commission. It is proposed to extend the hydro lines from Owen Sound and get current from Eugenia. Later it is proposed to develop power on the Sauguen River.

Edmonton, Alta.—Surplus machinery to the present estimated value of about \$2500 is in the hands of the streets de-

partment, and will probably be offered for sale. The list of seventeen machines includes one gasoline road roller, two street sprinklers, four horse sweepers, two road graders, one mud scraper, one steam roller, and one automobile.

Peterborough, Ont.—The City Council will make certain recommendations to the Hydro Commission for extensions and improvements to both the street railway and the gas plant. It is understood that the Hydro engineers have already begun an estimation of the cost of certain extensions of the street railway which may materialize this year.

Preston, Ont.—The Town Council has authorized that the following supplies be purchased; 500 feet hose; 100 feet $\frac{3}{4}$ in. hemp rope; 1 peerless hose clamp; 2 shutoffs for hydrants; 1 shutoff tap $1\frac{1}{8}$ in. to replace a screw tip; 2 small nozzles $1\frac{1}{4}$ in., 2 in. tips, 1 hasement nozzle; 1 smoke helmet; 2 life belts and detachable ladder straps; 2 dozen washers for hose couplings; half dozen hose couplings; 2 dozen brass bands for hose couplings; half dozen hose straps for ladders; first aid kit; springs for storm doors.

GENERAL

Hamilton, Ont.—The Shipman, Halton Knitting Co., are making preparations for the construction of a new factory.

Winnipeg, Man.—The Richardson Grain Separator Co., of Minneapolis, propose erecting a plant here in the spring.

London, Ont.—The Hobbs Mfg. Co. contemplate building a large extension to their local art glass etc., manufacturing plant.

Paris, Ont.—Penmans Ltd., will build an addition to their factory to cost about \$30,000. Schultry Bros., of Brantford are the contractors.

Montreal, Que.—The Canadian Consolidated Rubber Co., will occupy the factory on Inspector Street to be shortly vacated by the Ames-Holden-McCready Co.

London, Ont.—The Quaker Oats Co., whose Canadian factory was recently burnt out at Peterboro, have purchased the plant of the Canadian Cereal and Flour Mills Co. here, and will carry out extensive developments there for the manufacture of their product.

Montreal, Que.—The Ames-Holden-McCready Co., boot and shoe manufacturers propose making extensive alterations and additions to their plant on Mount Royal Ave, East. Plans are ready and contracts will be let shortly. Considerable new machinery of the latest type will be installed. N. R. Feltes is general manager of the company.

Simcoe, Ont.—One of the worst fires here in many years occurred on Feb. 7, when the entire plant of the Simcoe Lithographing Co. was destroyed, involving the loss of something like \$200,000 in valuable machinery and stock, both of which will be difficult to replace. It is understood that both the building

and contents were insured. The officers of the company are endeavoring to secure new quarters in which to carry on their business temporarily.

TENDERS

Toronto, Ont.—Tenders addressed to the chairman of the Toronto Electric Commissioners will be received until March 28, for synchronous condensers. Specifications may be obtained at the office of the Purchasing Agent, 15 Wilton Ave., Toronto.

Winnipeg, Man.—Tenders will be received up to March 15, by R. D. Waugh, Chairman of Commissioners, Greater Winnipeg Water District, for the supply of approximately 12,500 feet of 48-in. and 1,300 feet of 60-in. cast iron pipes, together with specials and gate valves. Specifications on application to the offices of the District, 501 Tribune Building, Winnipeg.

Toronto, Ont.—Tenders will be received, addressed to the Chairman, Board of Control, City Hall, up to Feb. 27., for the construction of a drainage system (wrought iron pipe), for the Rosedale bridge, Bloor Street Viaduct. Specifications and forms of tender may be obtained upon application at the Bloor Street Viaduct field office, 89 Castle Frank Road, Toronto.

Windsor, Ont.—Tenders will be received up to Feb. 28, 1917, for the construction of the superstructure of:— (a) One 70-foot clear span bridge. (b) One 80-foot clear span bridge. (c) Two 100-foot clear span bridges. Plans and specifications may be seen at the office of J. J. Newman, Davis Block, Windsor, Ont., or at the office of H. J. Rocheleau, Esq., Stoney Point, Ont.

Hamilton, Ont.—Tenders will be received by the Board of Control up to March 5, for the supply of ordinary and special castings, iron pipe, hydrants, valves, extension boxes. Lead pipe—Pig lead, rubber hose, rubber boots, road oil, lubricating oil, flux, fuel oil, coal oil, gasoline, brass work, including ordinary and special brass castings for water department, hardware, etc. Specifications may be obtained at the office of E. R. Gray, City Engineer.

PERSONAL

Brigden, Ont.—The hydro-electric by-law was carried by a large majority.

New Toronto, Ont.—A new Hydro-Electric sub-station is to be built, as the present one is not adequate to supply power to the number of new concerns locating here.

William Lyon Mackenzie, bridge engineer of the C.N.R., died at his home in Winnipeg on Feb. 8, at the age of 57 years. Mr. Mackenzie formerly was connected with the C.P.R. and Grand Trunk Railways.

E. L. Cousins, chief engineer of the Toronto Harbor Commission, has been elected president and **J. R. W. Ambrose**, chief engineer, Toronto Terminal Rail-

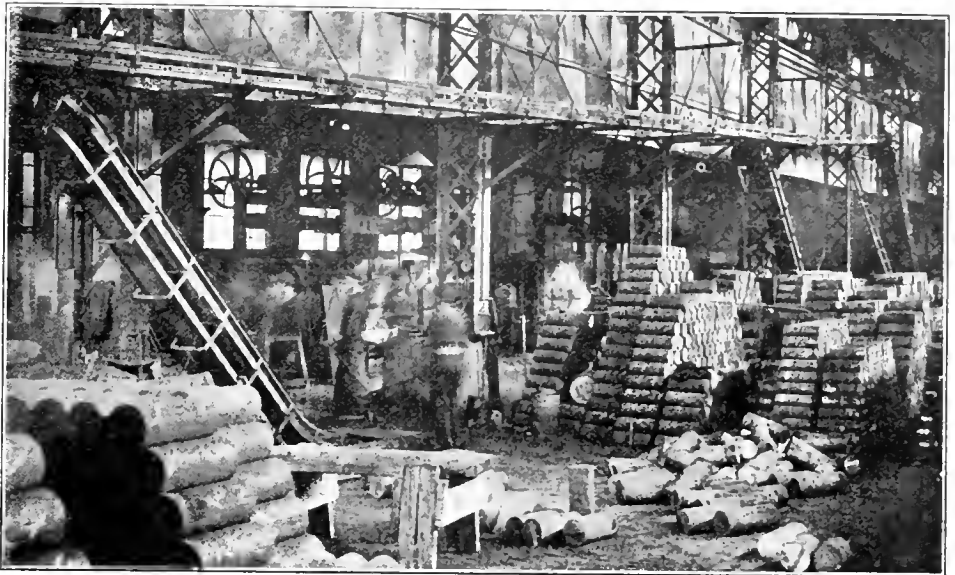

Steel Shell Forgings or Billets of any size or weight will move any distance or about curves upon our specially constructed Gravity Carriers and Incline or Horizontal power devices. No labor required.

Canadian Mathews Gravity Carrier Co., Toronto, Ont.

We are qualified Tool, Die, Jig, Gauge and Fixture Makers.

WRITE US.

Windsor Machine & Tool Works.
WINDSOR, ONT.

OVENS

Enamelling and Varnishing Ovens heated by Gas, Electricity, Steam or Coal.
Write for Booklet.

Brantford Oven & Rack Co., Ltd.
Brantford, Canada.

**MAKE YOUR DOLLARS
FIGHT
AT THE FRONT.
BUY
DOMINION OF CANADA
THREE-YEAR
WAR SAVINGS CERTIFICATES**

\$ 25.00	FOR	\$21.50
50.00	“	43.00
100.00	“	86.00

INDIVIDUAL PURCHASES LIMITED TO \$1500.

FOR FULL PARTICULARS APPLY AT ANY BANK
OR ANY MONEY ORDER POST OFFICE

JAN. 9, 1917

FINANCE DEPARTMENT
OTTAWA

PATENT ATTORNEYS

BABCOCK & SONS

ESTAB. 1877.

PATENTS—TRADE MARK—DESIGNS
IN ALL COUNTRIES

Book "Patent Protection"—Free, Master
of Patent Laws, Formerly Patent Office
Examiner.

99 St. James St., - Montreal, Que.
Branches: Ottawa, Washington.

RESEARCH BUREAU

REPORTS BY EXPERTS ON SCIENTIFIC, TECHNICAL AND INDUSTRIAL DEVELOPMENT.
SPECIAL RESEARCHES ARRANGED.

PATENTS, TRADE MARKS, ETC.

HANBURY A. BUDDEN CABLE ADDRESS
712 DRUMMOND BLDG., MONTREAL "BREVET"

PATENTS

Fetherstonhaugh & Co.
Patent Solicitors, Head Office,
Royal Bank Bldg., Toronto,
Ottawa Office, 5 Elgin St.
Send for our Plain Practical
Pointers, Copy of National
Progress, in which our patents
are advertised, mailed free.

PATENTS TRADEMARKS AND DESIGNS

PROCURED IN ALL COUNTRIES

Special Attention given to Patent Litigation
Pamphlet sent free on application.

RIDOUT & MAYBEE 59 Yonge Street
TORONTO, CANADA

MacKinnon, Holmes & Company, Limited

Design, manufacture and
erect all classes of Steel
Work.

Specialties:-

Bridges
Oil and Water Tanks
Penstocks
Coal and Coke Bins
Smoke Flues & Stacks.

Prompt deliveries assured.

Designs and Estimates from Head
Office at

SHERBROOKE, QUE.

engineering undertaking in Eastern Canada.

C. Kelso, for seventeen years in the employ of the Grand Trunk Railway System, and recently occupying the position of contract inspector in the motive power department, has been made master mechanic at the G.T.R., Stratford Shops, succeeding Robert Patterson resigned.

TRADE GOSSIP

U.S. Steel Tonnage.—The unfilled orders of the United States Steel Corporation on January 31 last were 11,474,054 tons, a decrease of 73,232 tons compared with December 31.

The Canada Metal Co. held their annual convention at Toronto on Feb. 12 and 13. Salesmen from all over Canada attended the sessions which were presided over by W. G. Harris Jun.

Cheddite, Ltd., has had the name of the concern changed to that of Munitions & Metal Products, Ltd., with powers extended to manufacture explosives and munitions of all kinds.

Canadian Allis-Chambers Ltd., Toronto, have been awarded a contract for a Lidgewood cableway excavator system in connection with the Chippewa Creek development at Niagara Falls for the Ontario Hydro-Electric Commission.

Ralph D. Norton, Craig Street, Montreal has secured an exclusive agency for Canada for the John Inghworth, Steel Co., of Frankfort, Pa. This concern has been established since 1855 and they make high grade crucible steel and also special open hearth steel.

Hadfield Offer Stands.—It is reported from Washington, D.C., that the contracts for more than \$3,000,000 worth of armor-piercing shells let by the navy to Hadfields, Limited, the English concern, may be filled despite the British Government order that the company should not proceed with the work "so long as the exigencies of war continue."

Smokeless Powder Option.—Advices from New York state that the British Government has exercised an option on an additional 9,000,000 pounds of smokeless powder to be manufactured by the Aetna Explosives Co. This order, according to an officer of the company, is valued at \$5,000,000, and is the second order for that quantity received from this source. A further option for an equal quantity is held by Great Britain and may be exercised before the end of July of this year.

Empire Trade Development.—Advices from London state that plans for the promotion of Empire Trade are developing rapidly. Already responses have been received from 28 governments to the movement for concerted co-operative action in the direction of having purchases made in every instance possible from British concerns. In an article reviewing the situation, the *Glasgow Herald* says:—

"For some time the Trade and Industry Committee of the Royal Colonial

Institute has been engaged upon the work of encouraging the establishment of new industries in the British Empire with a view to giving a measure of confidence and security to capital to be embarked therein, as well as assisting the expansion of existing industries.

"As a result of a resolution the committee has been in communication with the Governments and Chambers of Commerce of the Dominions and colonies with a view to urging the necessity of making it obligatory on all Government and municipal bodies to purchase Empire-made goods, and to place all contracts as far as possible with British firms. Such action in the opinion of the committee would prove a strong factor in stimulating the establishment of new and the growth of existing industries, as well as consolidating inter-Empire trade.

C. G. Railway Finance.—Hon. Frank Cochrane stated in the House on Aug. 1, 1914, to Nov. 30, 1916, \$9,920,249 had been expended on the construction of the Hudson Bay Railway. Mr. Cochrane said that the total receipts on Canadian Government railways during the financial year to Dec. 31, 1916, had been \$18,658,956, and expenditures had been \$18,342,733. He stated that 74 Intercolonial Railway engines had been sold to the National Transcontinental Railway, and that 32 I.R.C. engines were in use on the N.T.R. between Moncton and Winnipeg; that 33 I.R.C. passenger and 174 freight cars had been sold to the Transcontinental Railway. The Minister also said that 553,856 tons of coal had been purchased by the Canadian Government Railways in the United States last year.

Licenses for Ships Leaving Canada.—The situation caused by the German submarine blockade is being given consideration as far as the sailing of vessels of Canadian register are concerned by a ship licensing committee appointed by the Government to control Canadian steamship transportation. The committee is composed of Alec. Johnston, Deputy Minister of Marine; F. C. T. O'Hara, Deputy Minister of Trade and Commerce; Commissioner of Customs McDougald, and G. J. Desbarats, Deputy Minister of Naval Service. The committee has issued scores of licenses during the time it has been in control. No ship is allowed to leave Canada without such license and no license is given unless the committee is assured the vessel's trip will perform the most useful possible service to Canada and the Allies in view of the shortage of tonnage.

May Electrify T. & N. O. Railway.—J. L. Englehart, chairman of the T. & N. O. Railway Commission, said that the commission is preparing to electrify the line, and that during the past two years the road has been re-surveyed and plans prepared for this work. Electricity, he said, is in his opinion the future power of the province. Greater co-operation and big expenditure, he said, were the solution of the transportation question. Relief from the present congestion cannot, however, be hoped for during the progress of the war,

as conditions differ from all times in history. The Moose water powers, he said, though secluded, are readily accessible from all parts of Canada, and the fact that nitrate, which is used in the manufacture of explosives, is obtainable near this power supply, would suggest that the property is of Imperial importance, and should be developed immediately.

Port of Montreal.—The annual report of the Montreal Board of Trade showed the trade of Montreal to be in an excellent condition. The figures of the trade of the port of Montreal show an unprecedented increase, the total exports amounting to \$382,741,463, which, compared with \$155,685,953 in 1915, show an increase of \$227,055,510, or 145 per cent. This increased volume of business is in the main due to orders placed in Canada for munitions and supplies for the Allies. The imports amounted to \$194,924,348, as against \$115,919,977 the previous year, an increase of \$79,004,371, or 68 per cent., which would have been considered extraordinary at any other time although by comparison with the increase in exports it is inconspicuous. The customs receipts in Montreal amounted to \$32,915,686, an increase of eleven million dollars over 1915, and of nearly seven million dollars over the highest figure hitherto, \$26,016,631 in 1913.

CONTRACTS

Port Arthur, Ont.—The Eastern Terminal Elevator Co. have awarded a contract for the construction of an elevator to Barnet & McQueen Co.

Port Arthur, Ont.—Contracts have been awarded to the Barnett-McQueen Co., for the new Eastern Terminals' 2,000,000-bushel elevator, which is to be constructed on the waterfront.

Niagara Falls, Ont.—In connection with the Chippewa Creek development contracts for rock drills and air compressor plants have been awarded to the Sullivan Machinery Co., Chicago.

Edmundston, N.B.—The Structural Steel Co., Montreal, have been awarded the steel contract in connection with the erection of a pulp and paper mill by Fraser, Limited. H. I. Ferguson, 200

Chatham, Ont.—The Imperial Munitions Board has awarded a contract for the construction of a large number of boxes for shells to the S. Hadley Lumber Co. The boxes will be used for shipping the 6-in. shells that are being manufactured by the Hayes Wheel Co.

MARINE

Victoria, B.C.—Yarrows, Ltd., of Esquimalt, have secured the contract for way Co., vice-president of the Engineers' Club, Toronto.

John George Macklin, civil engineer died near London England on Feb. 5. The deceased was born in England and came to Canada as a young man. He was associated with several prominent

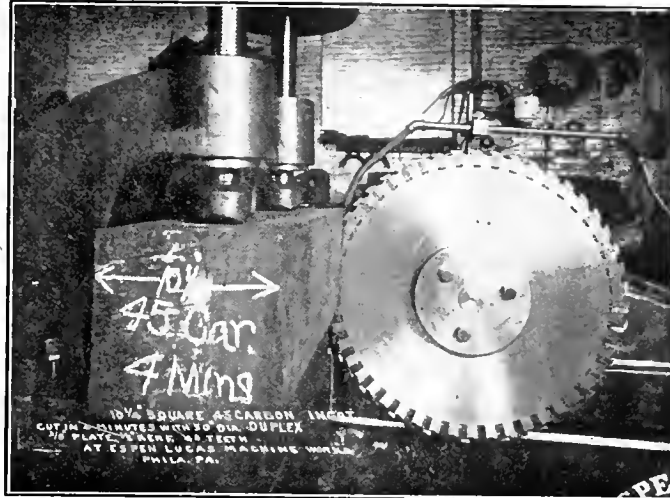

Circular Metal Cutting Saw Blades for Any Type of Machine

Let us demonstrate what a saving can be made by installing a **HUNTER "DUPLEX" Inserted Tooth Blade**

Write for information
HUNTER SAW & MACHINE CO., Pittsburgh, Pa., U.S.A.

**One Inch Space
\$1.00 Per Issue
on Yearly Order.**



METAL STAMPINGS

We are manufacturers of stamped parts for other manufacturers.

We do any kind of sheet metal stamping that you require. Our improved presses and plating plant enable us to produce the finest quality of work in a surprisingly short time.

We can finish steel stamping in Nickel, Brass or Copper.

Send us a sample order.

W. H. BANFIELD & SONS
372 Pape Avenue, Toronto, Can.

A PRICE PYROMETER makes it cert ain

Get a Record of Working Temperatures

Uncertainty is a time and effort waster — to be sure at a glance means efficiency. There is no "doubt," when you have a Price Pyrometer.

See that there is a Price Indicating Instrument within sight of every furnace in your heat-treating department. And have a Price Recording Pyrometer in your office to get a record of working temperature.

Let us send you our Catalogue and full particu-

lars — How you can make it certain.

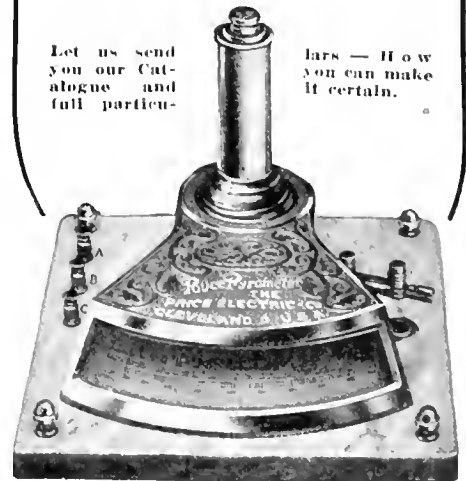

THE PRICE ELECTRIC CO.
12368 Euclid Avenue, CLEVELAND, OHIO

I BELIEVE

In Safety First and always.
 In providing for the Health of my Fellow
 Workmen.
 In Light and Air and sanitary Working Con-
 ditions.
 In clean, fresh drinking water for everybody.
 In the Safety, Economy and Man-betterment.

PURO SANITARY DRINKING FOUNTAIN

(MADE IN CANADA)

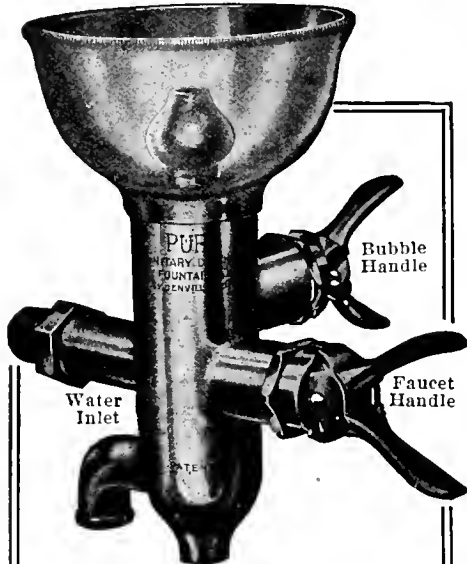

The loss of a man through impure drinking water is a crime that "the front office" must bear.
 An ugly statement, isn't it? But true, absolutely.
 When a man comes to work in your factory he puts his health in your keeping.
 Are you willing to take chances on such a trust?
 Impure drinking conditions are responsible for more tragedies than any machine ever built.
 Apply the "Safety First" Principles to your water supply; don't deny your men a clean, fresh drink of water.
 Conserve their health and they will improve your profits; make yourself as worthy of the name of "employer."
 Install the Gold Medal winner Puro in your plant, office and shop alike.
 The only Sanitary Drinking Fountain that is safe, sanitary, simple, automatic in control and easily attached.
 Let us tell you just what it will cost you to

"PURO - FY"

YOUR WATER SUPPLY

Puro Sanitary Drinking Fountain Company
 147 University Ave., Toronto, Canada

"Barnes-Made" SPRINGS

are unusual in service and wear

They are the result of sixty years' experience, unsurpassed equipment and highly skilled workmanship.

A trial will convince you that "Barnes-Made" Springs are the best buy.

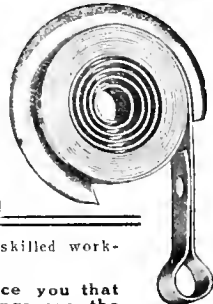

Established 1852

THE WALLACE BARNES COMPANY
 218 South St., Bristol, Ct., U.S.A.
 Mfrs of "Barnes-made" Products
 Springs, Screw Machine Products, Cold Rolled Steel and Wire

overhauling and repairing the Norwegian steamer Strinda. The vessel is now on her way to Vancouver from Vladivostok, under charter to the C.P.R.

INCORPORATIONS

The Gladstone Brush Mfg. Co. has been incorporated at Ottawa, with a capital of \$50,000, to manufacture brushes of all kinds at Toronto. The incorporators are: Eldon Moir, Donald L. McDonald and Oral N. Birehard, all of Toronto.

T. F. Shurly Co., has been incorporated at Ottawa with a capital of \$200,000 to manufacture knives, axes and edged tools of all kinds at St. Catharines, Ont. The incorporators are: Theodore F. Shurley, George B. Burson and Harry Short, all of St. Catharines, Ont.

The Port Arthur Pulp & Paper Co., has been incorporated at Toronto with a capital of \$2,000,000 to manufacture pulp and paper. The head office will be at Port Arthur and the provisional directors are George H. Sedewick, James Aitchison and Duncan HeArthur all of Toronto.

Standard Steel & Tempering Co., has been incorporated at Ottawa with a capital of \$50,000 to construct and operate steel, iron, and brass plants, foundries and furnaces etc. The head office is at Montreal and the incorporators are S. H. R. Bush, B. Robinson and T. E. Durocher all of Montreal.

CATALOGUES

The Valve Twins is the title of a bulletin being distributed by the Homestead Valve Mfg. Co., Homestead, Pa., illustrating the "Hovaleo-Homestead" blow-off combination valve.

Sub-Aqueous Lubrication, Bulletin issued by the Crew Leviek Co., Philadelphia, Pa., dealing with sub-aqueous or under-water lubrication in hydro-electric stations with special reference to hydro-turbine lubrication at McCall's Ferry, Pa. The preparations described on "Turboglio" for under-water lubrication and "hydroelio" for governor lubrication.

Screw Machines Bulletin, dealing with the "Foster" No. 5 screw machine made by the Foster Machine Co., Elkhart, Ind. A description is given of the various parts and mechanisms accompanied by illustrations showing their general arrangement and also of the machine. Specifications are included of the two types, and complete set of standard tools for using on the machine are illustrated and described.

BOOK REVIEWS

Handbook of Machine Shop Electricity, by C. E. Clewell. 461 pages 6 3/4 x 4 in. Fully illustrated. Published by the McGraw Hill Book Co., Inc., New York City. Price \$3.00 net. With a more general use of electricity in the machine shop, and which is increasing every day, a volume such as this will be of great assistance to the mechanic. It has been written from the

point of view of the practical shop man and special attention has been paid to those subjects which apply in one way or another to particular uses of electric power in shop operations. The book was undertaken about two years ago at the suggestion of the editors of the *American Machinist* who desired to fill what they considered a need for a convenient electrical reference book adapted to the machine shop. The subject matter in the book is grouped under ten main headings, each being covered in a section. Each section has its own index of topics which are dealt with in alphabetical order. While there is also a list of contents at the end, and also a general index. The main headings cover the following subjects:—Abbreviations, terminology and units; Circuits; Costs; Communication and distant control; Current supply, generators and transformers; Electrochemical; Soldering and welding application; Heating and magnetic apparatus; Lamps and shop lighting; Measuring instruments and measurements; motors and applications. Each subject is dealt with in a complete and comprehensive manner, and the information contained in this volume will be valuable to the reader who will derive much practical benefit from a perusal of its pages. The book contains a large number of illustrations which help considerably in obtaining a clear and working understanding of the text.

Port Arthur, Ont.—At the plant of the Western Dry Dock & Shipbuilding Co., work is now started on two more ocean-going freighters. Four more ocean-going freighters are to be built when these two are completed, and contracts for two more are now being arranged, making eight boats to be built in all. These freighters will be the same size as the Thorjerd and Blaamyra, recently launched.

SPECIAL MACHINERY

GAUGES, FIXTURES, DIES
AND
PRECISION TOOLS

WE HAVE THE
MOST MODERN
EQUIPMENT
TO HANDLE
ANY CLASS OF WORK

CANADIAN DISTRIBUTORS FOR THE
ALBANY PATENT ROTARY PUMP

Albany Pump Co.

16 Pearl St., TORONTO, Canada
Phone Ad. 2511 A. W. Bennet, Manager

CANADIAN MACHINERY AND MANUFACTURING NEWS

A weekly newspaper devoted to the machinery and manufacturing interests.

Vol. XVII.

TORONTO, FEBRUARY 22, 1917

No. 8

EDITORIAL CONTENTS

The Chilled Iron Car Wheel in Steam Railroad Service	145-150
General	150
No Appeals from Business Tax....B.C. Lumber Output Increase....Railway Facilities Inadequate.	
Editorial Correspondence	151-152
Special Design Headstock Spindle....Nosing 4.5 ins., Mark VII. High Explosive Shell.	
General	153-154
Safe Oxy-Acetylene Welding Equipment....Air Cylinder Explosion.	
Spokes in Industry's Wheel	155-156
Harry Alton Wilson.	
General	156
3,231,000 Women at Work in Britain....Electrical Machinery Openings in Chile.	
Safe Practice at Blast Furnaces and Its Development—IV	157-159
General	159
Notes on Hand Grinding....Paint Coatings Thickness.	
Progress in New Equipment	160-161
Die Muzzling Machine....Large Heavy Duty Lathes.	
Editorial	162
Business Outlook Continues Favorable.	
Industrial Notabilities	163
Percy Ford Smith.	
Selected Market Quotations	164-165
The General Market Condition and Tendency	165-168
Weekly Summary....Montreal Letter....Toronto Letter....Trade Increase with BritainEquipment Needs of Mesopotamia Railroad.	
Industrial and Construction News (Advtg. Section)	60

THE MACLEAN PUBLISHING COMPANY, LIMITED

JOHN BAYNE MACLEAN, Pres. H. T. HUNTER, Vice-pres. H. V. TYRRELL, Gen. Man.

Publishers of Hardware and Metal, The Financial Post, MacLean's Magazine, Farmer's Magazine, Canadian Grocer, Dry Goods Review, Men's Wear Review, Printer and Publisher, Bookseller and Stationer, Canadian Machinery and Manufacturing News, The Power House, The Sanitary Engineer, Canadian Foundryman, Marine Engineering of Canada.

Cable Address: Macpubco, Toronto; Atabek, London, Eng.

ESTABLISHED 1887.

CANADIAN MACHINERY AND MANUFACTURING NEWS

PETER BAIN, M.E., Editor B. G. NEWTON, Manager.
Associate Editors: A. G. WEBSTER, J. M. WILSON, J. H. RODGERS.

CHIEF OFFICES:

CANADA—Montreal, 701-702 Eastern Townships Building; Toronto, 143-153 University Ave., Telephone Main 7324; Winnipeg, 22 Royal Bank Building, Telephone Garry 2343.

GREAT BRITAIN—LONDON, The MacLean Company of Great Britain, Limited, 88 Fleet Street, E.C., E. J. Dodd, Director. Telephone Central 1290. Cable Address: Atabek, London, England.

UNITED STATES—New York, R. B. Huestis, 115 Broadway, N.Y., Telephone Rector 8971; Boston, C. L. Morton, Room 733, Old South Building, Telephone Main 1204; A. H. Byrne, 1401 5-6-7 Fort Dearborn Bldg., 105 W. Monroe St., Chicago, Telephone Randolph 3231.

SUBSCRIPTION PRICE—Canada, Great Britain, South Africa and the West Indies, \$1.00 a year; United States, \$3.50 a year; other countries, \$1.00 a year; Single Copies, 15 cents. Invariably in advance.

HENDEY 18-inch GEARED HEAD LATHE

8 mechanical changes of speed for spindle with driving shaft running at constant speed, 4 direct and 4 through back gears.

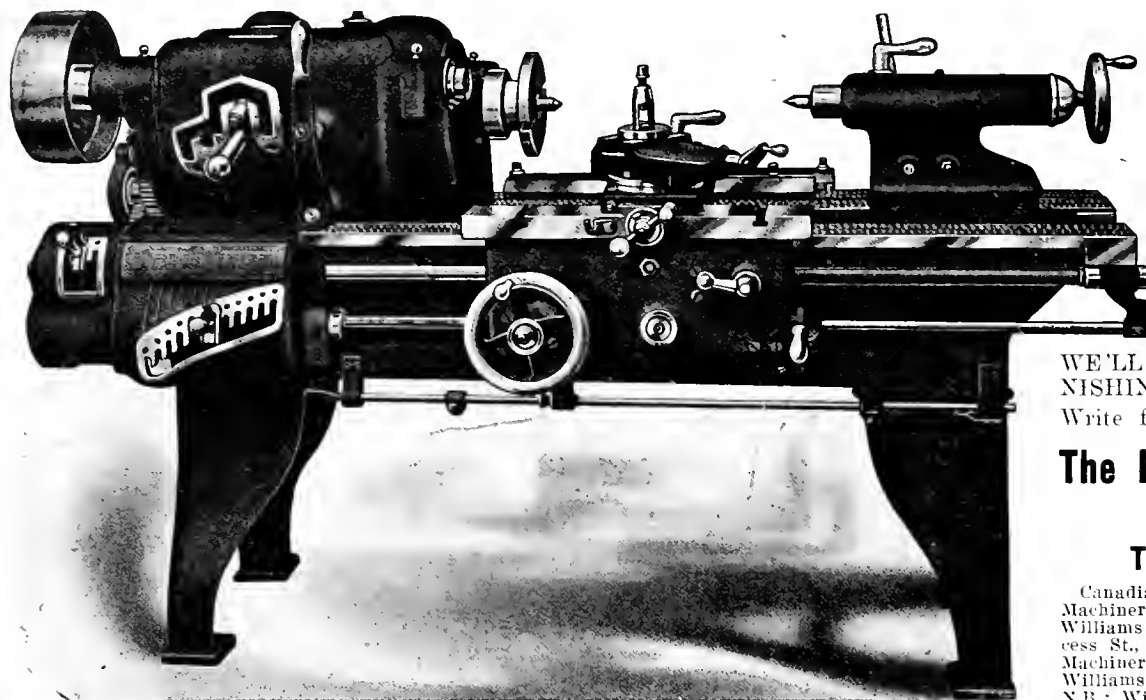

36 DIFFERENT THREADS AND FEEDS are had through Mounted Change Gearing, each change being quickly made through controlling handles in Gear Boxes.

BEFORE PURCHASING A NEW LATHE INVESTIGATE THE HENDEY SERVICE.

WE'LL HELP YOU BY FURNISHING LIST OF USERS. Write for descriptive circular.

The Hendey Machine Company Torrington, Conn.

Canadian Agents: A. R. Williams Machinery Co., Toronto, Ont.; A. R. Williams Machinery Co., 260 Princess St., Winnipeg; A. R. Williams Machinery Co., Vancouver; A. R. Williams Machinery Co., St. John, N.B.; Williams & Wilson, Montreal.

INDEX TO ADVERTISERS

Aeroplane Products, Ltd.	108	Darling Bros., Ltd.	109	Jencks Mach. Co.	9	Pritchard-Andrews Co., of Ottawa..	28
Aikhead Hdwe. Co.	61	Davenport Loco. Works	14	Johnson Mach. Co., Carlyle.....	97	Puro Sanitary Drink'g Fountain Co.	67
Albany Pump Co.	64	Davis, W. F., Machine Tool Co....	73	Joyce, Geo. A., Co.	106	Racine Tool & Machine Co.	27
Allen, John F., Co.	92	Delo Smelting & Refining Co....	4	Jersey City Mach. Co.	106	Ridout & Maybel	83
American Pulley Co.	109	Delta File Works	62	Kasnit, Limited	9	Reliance Mach. Co.	73
Armstrong Bros. Tool Co.	121	De Mooy Mach. Co.	117	Kempsmith Mfg. Co.	51	Riverside Machy. Depot	72
Armstrong, Whitworth of Canada ..	7	Dept. of Finance	61, 78, 103	Kennedy, Wm. & Sons	12	Rivett, Lathe & Grinder Co.	126
Atlas, Wm., & Co., Ltd.	11	Dickow, Fred. C.	65	Ker & Goodwin	65	Rockford Drilling Machine Co.	119
Atlas Crucible Steel Co.	8	Dodge Mfg. Co.	99	Keystone Mfg. Co.	115	Roeiford Machine & Tool Co.	19
Aurora Tool Works	119	Dominion Belting Co., Ltd.	66	L'Air Liquid Society	125	Roper & Co., C. F.	108
B. A. B. Model Mfg. Co.	84	Dominion Bridge Co.	104	Landis Machine Co.	32	Scott Machy. Co., G. H.	84
Babcock & Sons	64	Dominion Forge & Stamping Co.	121	London Bolt & Hinge Co.	65	Scott, F. H.	109
Baird Machine Co.	108	Dominion Iron & Wrecking Co.	104	Lyman Tube & Supply Co.	96	Sheldons, Ltd.	22
Banfield, E. J., & John	12	Dominion Machinery Co.	72	Macanab, John, Machy. Co.	16	Shore Instrument Co.	107
Banfield, W. H., & Sons	61	Dominion Steel Foundry Co., 19 and 105	105	Magnolia Metal Co.	98	Shuster Co., A.	106
Barnes, W. F., & John	119	Eastern Mach. Screw Corp.	90	Main Belting Co.	101	Simmons Mach. Co., Inc.	90
Barnes, Wallace, Co.	67	Elmes, Chas. F.	25	Marion & Marion Equipment Co.	64	Skinner Chuck Co.	108
Bemis & Call Hardware & Tool Co.	113	Erie Foundry Co.	115	Manufacturers Equipment Co.	92	Shoem. Avram & Slocum	91
Bertram, John, & Sons Co., Ltd.	8	Fetherstonhugh & Co.	64	Marsh & Henthorn, Ltd.	82	Smart-Turner Mach. Co.	88
Front cover and page 1		Fitzgerald, W. H. J.	70	Matthews, Jas. H., & Co., Inc.	106	Smooth-On Mfg. Co.	121
Bertram's, Limited	65	Fleck, Alexander, Limited	65	McCabe, J. J.	28	Standard Alloys Co.	10
Blake Pump & Condenser Co.	85	Ford Chain Block & Mfg. Co.	102	McCoy-Brandt Machy. Co.	70	Starret Co., L. S.	67
Bliss, E. W., Co.	23	Ford-Smith Mach. Co.	31	Mcdougall Co., H.	Inside back cover	St. Clair Bros.	69
Brantford Oven & Rack Co.	63	Foss & Hill Machy. Co.	3	McKenzie, The D. K. Machy. Co.	27	Steele, Ltd., James	65
Bristol Company	105	Foundry & Mach. Co.	Inside back cover	McLaren, J. C., Bldg. Co.	107	Steele Co., of Canada	3
Brown, Boggs	20	Frost & Co., Albert	18	Mechanical Engineering Co.	29	Stepoe, John, Co.	65
Brown Engineering Corp.	98	Francis & Co.	107	Metalwood Mfg. Co.	23	Stirk & Sons, John	65
Brown & Sharpe	113	Galt Mach. Setew Co.	29	Millers Falls Co.	26	Stacker-Rumley-Vachs Co.	73
Brownell Machy. Co.	76	Gardner Machine Co.	109	Millibond Co., W. K.	92	Stow Mfg. Co.	91
Brown's Copper & Brass Rolling Mills	79	Garlner, Robt., & Sons	104	Mosley & Hawley	188	Swedish Steel & Importing Co.	5
Buden, Hanbury A.	64	Garlock-Walker Machy. Co.	20	Montgomery Smith & Co.	28	Strimington Co., T. H.	76
Butterfield & Co., Inc.	95	Garvin Machine Co.	39	Montreal General Tool Co.	10	T. C. M. Mfg. Co.	58
Can. Bond Hanger & Combng Co.	100	Geometric Tool Co.	59	Modern Machy. Ex.	75	Tabor Mfg. Co.	107
Canada Machinery Corporation	100	Gerstner & Sons, H.	85	Montreal Machy. & Supplies	103	Tallman Brass & Metal Co.	116
Outside back cover		Globe Instrument Co.	85	Morse Chain Co.	77	Taylor Instrument Co.	86
Canada Metal Co.	98	Globe Machine & Stamping Co.	119	Modern Tool Co.	91	Toledo Machine & Tool Co.	26
Canada Wire & Iron Goods Co.	73	Gosley & Edlund	113	Morton Mfg. Co.	63	Toomey, Frank A.	74
Can. B. K. Morton Co.	94	Grant Gear Works, Inc.	108	Moteh & Merryweather Machy Co.,	69	Toronto Iron Works	106
Can. Blower & Forge Co.	94	Grant Mfg. & Machine Co.	115	Muir Wm., & Co.	65	Toronto Type Fdry. Co.	81
Can. Fishbanks-Morse Co.	110	Greenfield Machine Co.	90	Murphy Machine & Tool Co.	93	Toronto Welding Co.	68
Can. Billings & Spencer	110	Hall & Sons, J. H.	25	National Machinery Co.	109	Union Drawn Steel Co.	107
Can. Desmon, Stephen Mfg. Co.	96	Hannamut Car and Engine Works.	103	National Machine Tool Co.	107	Union Tool Chest Works	105
Can. Drawn Steel	104	Hamilton Gear & Machine Co.	106	New Metal Tool Steel Co.	79	United States Electrical Tool Co.	86
Can. Economic Lubricant Co.	101	Hamilton Machine Tool Works	20	New York Machinery Exchange	74	Vanadium Alloys Steel	6
Can. Hanson & Van Winkle Co.	89	Hanan & Co., M. A.	8	Nicholson File Co.	88	Victor Saw Works	26
Can. Inspection & Testing Laboratories, Ltd.	195	Hardinge Bros.	86	Niles-Bement-Pond, Inside front cover		Vulcan Crucible Steel Co.	9
Can. Metal Products	197	Hawkesbury Board of Trade	66	Northern Crane Works	195	Walcott Lathe Co.	84
Can. Steel Foundries, Ltd.	7	Henley Machine Co.	128	Norton, A. O.	178	Wells Bros. Co., of Canada	32
Can. Welding Works	8	Himoff Mach. Co.	108	Norton Co.	39	West Tire Setter	102
Carter Welding Co.	67	Hopburn, John T.	15	Nova Scotia Steel & Coal Co.	6	Whiting Foundry Equipment Co.	22
Cataraug Refining Co.	78	Hoyt Metal Co.	110	Oven Equipment & Mfg. Co.	82	Whitton Machine Co., D. E.	104
Chasman Double Pall Bearing Co.	100 and 101	Hunter Saw & Machine Co.	24	Parmenter & Bulloch Co.	178	Williams, A. R., Machinery Co., 7 and 59	59
Cheserman, Jas., & Co., Ltd.	178	Hungerford Brass & Copper Co.	80	Perrin, Wm. R.	23	Williams, J. H., & Co.	123
Cincinnati Milling Machine Co.	10	Hurlbut Rogers Machinery Co.	24	Peerless Machine Co.	27	Williams & Wilson	68
Cincinnati Pulley Machy. Co.	97	Hvale Engineering Works	93	Petrie, of Montreal, Ltd., H. W.	17	Windsor Mach. & Tool Works	63
Cleveland Wire Spring Co.	65	Ideal Tool & Mfg. Co.	94	Petrie, H. W., Ltd.	69 and 109	Winnipeg Gear & Engineering Co.	106
Corbet Foundry & Mach. Co.	44	Independent Pneumatic Tool Co.	80	Philadelphia Gear Works	106	Worth Engineering Co.	63
Cook, Asa S.	194	Iron Works, The	67	Phillville Foundry	63	Zenith Coal & Steel Products Co.	108
Cullen Machy. Co., C. W.	70	Jacobs Mfg. Co.	94	Positive Chute & Pulley Works.	108	Zim-Ho Mfg. Co.	88
Cushman Chuck Co.	197	Jardine Co., A. B.	117	Pratt & Whitney, Inside front cover			

The Chilled Iron Car Wheel in Steam Railroad Service

By G. W. Lyndon**

The chilled iron car wheel has been, since its introduction in the year 1850, the standard accessory of transportation, carrying as it does the car and its contents to every nook and corner of this continent traversed and served by steam railroads. In the accompanying paper an interesting description is given of its development towards meeting the increased rolling stock weight and capacity that have been found indispensable to a continued industrial expansion.

THE subject of the Chilled Iron Car Wheel is one of vast magnitude, comprehending as it does the vehicle by which the commerce of this continent is moved; at the same time its importance to the transportation world is not as fully recognised as might be, either by the public generally or our industrial community particularly. Statistics which will indicate the extent of the car wheel industry are shown in the U.S. Interstate Commerce Report for the year ended 1914 as follows:—

Total number of freight cars in commercial service	2,325,647
Total number of freight cars in company service	124,709
<hr/>	
Total	2,450,356
Add—Private car lines (approximately) ...	225,000
<hr/>	
Number of tons of freight carried, year ended 1914	1,109,271,040
<hr/>	
Tons of freight carried one mile, 54% of car capacity, exclusive of private car lines ...	288,318,890,210
Tons of car structure (estimated 18 tons per car)	363,402,465,012
<hr/>	
Total wheel burden carried one mile....	651,722,355,222 tons.

cars are equipped with the chilled iron wheel, therefore, we have, in commercial freight car service and company service, and private car lines in the United States alone, 20,332,687 chilled iron wheels. To this we must add the chilled iron wheels serving under passenger cars, engine tenders and street car lines, and we can safely and conservatively estimate the number of chilled iron wheels running to-day as about 25,000,000, taking into consideration those used in the Dominion of Canada, and the hundreds of thousands which have been shipped abroad and to Mexico and South America. 25,000,000 chilled iron wheels represent 8,000,000 tons of metal.

Initial cost at \$25.00 per ton \$200,000,000.00
Scrap value at \$15.00 per ton 120,000,000.00
25,000,000 wheels placed on a single track would make a solid line of wheels 13,000 miles in length, over one-half of the circumference of the earth. If they were placed on a single track with treads 2.3 feet apart they would encircle the globe. If they could be piled on top of each other, hub to hub, they would reach a height of 2,760 miles. To replace 25,000,000 chilled iron wheels upon the basis of 2,500,000 annual renewals requires ten years. 800,000 tons of metal are used annually to provide for 2,500,000 wheel renewals. From the receipt of the metal to the finished wheel ready for shipment, the metal must be handled about twelve times, so that to produce 2,500,000 wheels annually 800,000 tons of metal are required and 9-

Canada, representing millions of invested capital, and having a combined capacity of 20,000 car wheels per day, and having in mind the statistics to which I have just called attention, we must remember that the history of the development of the resources of North America is a history of the development of the chilled iron car wheel, because the railways could not have reached their present unparalleled development without the chilled iron car wheel, and it would require years and years of preparation to replace them with any other substitute.

What Chilled Iron Is

Chilled iron means what the name implies and is the result of the chilling or sudden cooling of molten cast iron when poured against an iron ring, which is part of the mould. Its discovery is said to have been accidental. In an English foundry, in the 18th century, the slopping over of a ladle of cast iron caused part of its contents to come in contact with cold iron lying on the floor of foundry. In breaking up this scrap it was discovered that the iron was white and much harder than that secured from the ordinary foundry process of pouring the metal into a sand mould. The result of this discovery was the introduction of chilled iron for plow points, faces of forge hammers, punches for punching holes in wagon tires, and rolls for rolling materials.

Chilled Iron for Car Wheels

During the first half of the nineteenth century, a number of attempts were made to introduce chilled iron for car wheel purposes, and many different designs were patented and introduced, with only meagre results. In the primi-

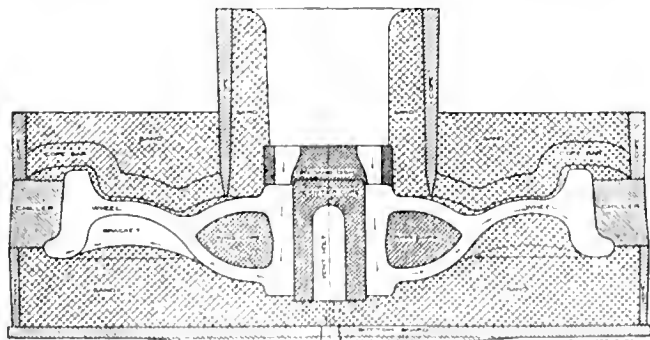

FIG. 1. CROSS SECTION OF CAR WHEEL MOLD SHOWING DIRECTION OF FLOW OF METAL.

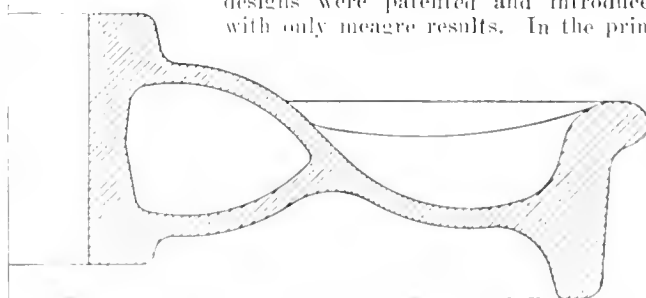

FIG. 2. WASHBURN PATTERN 525 LB. WHEEL FOR CARS OF 10 TONS CAPACITY.

An analysis of the rolling stock will show that 95 per cent. of all freight

600,000 tons of metal must be handled.

I speak for twenty-five manufacturers operating fifty foundries scattered from the Atlantic to the Pacific Oceans, located throughout the United States and

five days the form of the wheel was the ordinary flat spoke pattern with the hub split longitudinally in three places. The separation of the hub was for the purpose of relieving shrinkage strains

*From a paper read, Feb. 13, at the Canadian Railway Club, Montreal.
**President, Association of Manufacturers of Chilled Car Wheels, Chicago, Ill.

in cooling and preventing the arms and spokes from breaking. The hub was banded together with a wrought iron band and keyed onto the axle. In the year 1838, Geo. G. Lobdell invented a double plate wheel, the front and back plates extending from the hub to the rim, which subsequently evolved into the present pattern.

In the year 1850, a man arose to the situation and developed an idea, the im-

dangerous to use. Anyone by the use of the Scleroscope or Brinell methods can determine the relative hardness of the chilled iron wheel tread, as compared with other types.

The M.C.B. standard 725 lbs. wheel is poured in about twelve seconds. The balance of the mould consists of green sand and dry sand cores, all so scientifically arranged that the finished wheel possesses a gradual hardness of struc-

countered which must be relieved before the wheels are placed in service. During the earlier periods of manufacture, after the wheel was set, it was covered with ashes or hot sand and allowed to remain several days until nearly cold. Another method was to lay the wheel on the floor and apply heat to the tread, so that the temperature of the tread would be brought back to that of the plates and hub.

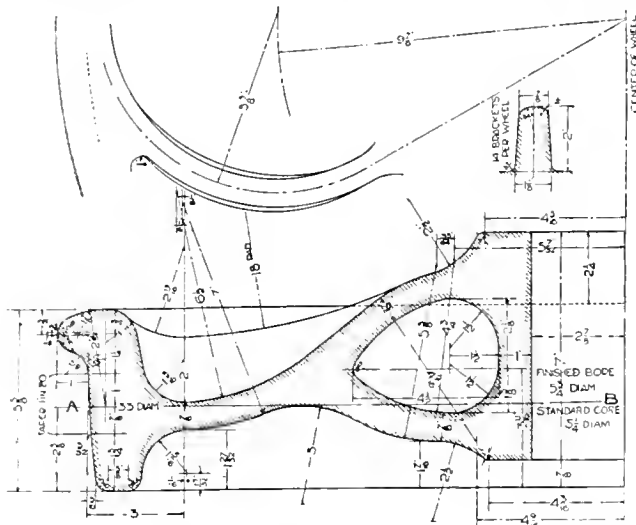

FIG. 3. M.C.B. STANDARD 625 LBS., 33-INCH C.I. WHEEL FOR CARS OF MAXIMUM GROSS WEIGHT, AND NOT EXCEEDING 95,000 LBS.

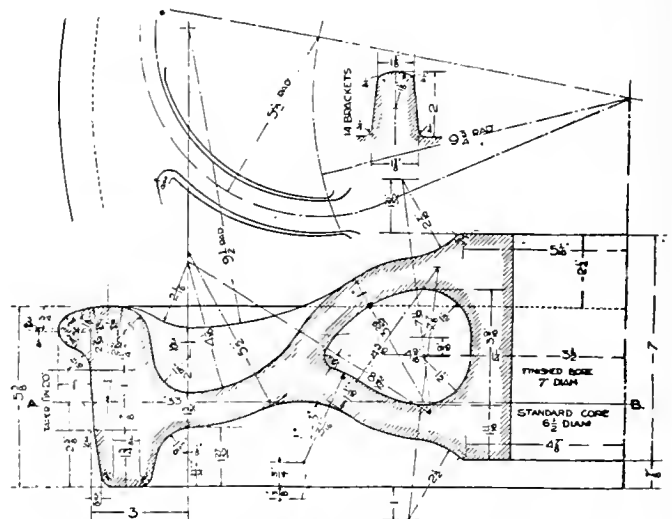

FIG. 4. STANDARD 725 LBS., 33-INCH C.I. WHEEL FOR CARS OF MAXIMUM GROSS WEIGHT, AND NOT EXCEEDING 161,000 LBS.

mensity of which was not dreamed of by him, but has since evolved into one of the most far reaching and important commercial industries in the country. From 1849 to 1860 there were eighty-eight patents granted for alleged improvements in the form of pattern. It was N. Washburn's belief that a solid casting weighing about 500 pounds could be produced that would serve as a car wheel which would require no machining, except as to axle fit and which could be placed into service under the then ten ton car and run on an iron rail for the life of the car.

Method of Manufacture—Pouring

The method of manufacture in so far as the formation of the wheel is concerned, is practically the same to-day as when first introduced, and consists of pouring the iron into a mould, part of which is sand and part iron. The tread or running surface of the wheel is formed by an iron ring or chiller against which is poured the molten metal, and the sudden cooling of molten metal transforms the soft gray colored metal to a metal white in color and harder than tempered steel. This white, hard iron which extends all around the tread of the wheel to a depth of one-half to three-quarters of an inch, yields more mileage per unit of metal worn than any other metal. There is no other metal known that produces so hard a tread that can be operated with safety, because if other metals can produce a tread as hard as the chilled iron wheel this same hardness will be apparent in the plates and the hub, and, therefore, brittle and

ture which is ideally adapted to service conditions, namely hard tread, soft plates and soft hub. Figure No. 1 shows a section of the mould in which the chilled iron wheel is cast, and the same principle of moulding has been in use ever since its introduction.

Annealing

We have found that a 725 lbs. M.C.B. wheel is poured in about twelve seconds. The molten metal is then subjected to different cooling conditions due to the complexity of the mould, which is made up partly of iron, partly of dry sand, and partly of green sand. That part of the mould which consists of iron is the

These crude methods were later displaced with the introduction of cooling pits lined with fire brick, each pit holding from ten to fifteen wheels. Just as soon as the wheel is solidified, it is removed from the mould red hot and placed in a pit maintained at the proper temperature, and by this process the tread and the plates and the hub resume an equilibrium of temperature and the wheels remain in the pits for several days until the shrinkage strains are

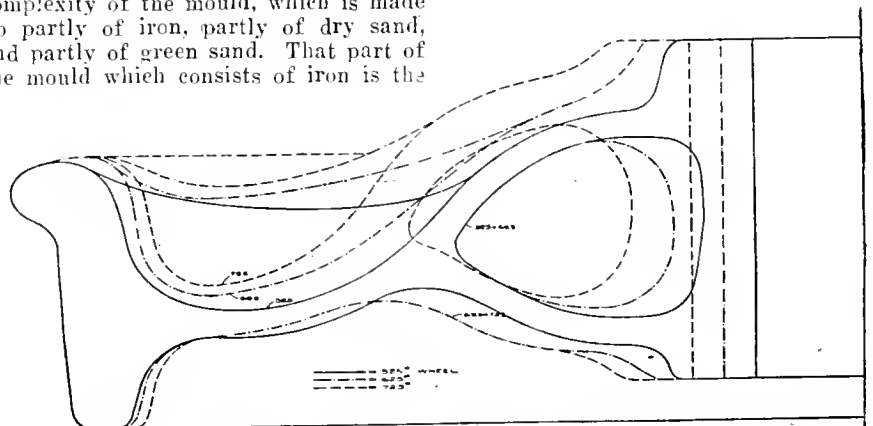

FIG. 5. COMPOSITE OF 525 LBS. WHEEL FOR CARS OF 10 TONS CAPACITY; 625 LBS. M.C.B. DESIGN FOR 30 TONS CAPACITY; M.C.B. DESIGN FOR 50 TONS CAPACITY CARS.

best conductor of heat, therefore, the tread or running surface is cooled almost instantaneously, whereas the plates and the hub, having been formed by dry and green sand, cool slowly. In consequence, shrinkage strains are en-

finally removed by the gradual and uniform cooling process.

The pouring and annealing are important parts of the method by which the wheel is made, but they are only two of the multitudinous processes required.

The intricacies of manufacture are only recognized by those who have actually engaged in the business, and complex problems are continually confronting the manufacturer from the assembling of the material to the finished wheel.

We have found the method of manufacture as to pouring has not been materially changed, and we have also found that the pattern introduced in 1850 by Washburn is the same in outline practically as that in use to-day. It will, therefore, be my purpose to show what has been done, and it will be found that the only thing that stands out prominently is that a little metal has been added to the wheel as the capacity of the car has been increased, but the increase in metal has been "grudgingly made," and never proportionate to the increase of duty required. Nevertheless, the wheel manufacturers, in the face of restrictions in weight and flange dimensions, have been successful in maintaining the chilled iron wheel up to a high standard. The chilled iron wheel is like Topsy in Uncle Tom's Cabin. It just grew, and we all realize the fact that the wheel is the most important part of the car structure.

Increases in Car Capacity and Wheel Weights

A 33 ins., 525 lbs., chilled iron wheel of the Washburn type, as shown in Fig. 2, became standard soon after the year 1850 for 10 ton freight cars, and also for passenger cars. Cars of this capacity remained standard for about thirty years. As late as 1875 there were only occasional cars having a capacity as high as 12 tons. The heaviest capacity passenger coaches weighed 18 tons. Sleeping and drawing room cars of twelve sections weighed 30 tons. The operation of railroads then was very different than at present. Interchange of traffic as we now know it did not exist. An official of a great railroad charged another with running freight trains as fast as twelve miles an hour. "The wear and tear is something terrible," said he. "It is pounding the track to pieces. Every ton of freight handled at that speed is carried at a loss. The reduction of speed to eight miles an hour will lessen the cost more than \$1,000 per day."

Such were the ideas of the foremost men in charge of transportation in the days of iron rails, hand brakes, link and pin couplers, fragile cars, etc. Under such conditions of light wheel loads, small flange pressures, slow speeds, low annual mileage, the wheels would last the entire life of the car. Wheel mileage obtained under such circumstances is sometimes erroneously used to indicate the superior service of wheels manufactured at that time. The ton mileage, which is the true basis for comparison, was extremely low as compared with wheel performance at the present time.

The introduction of the air brake, the automatic safety coupler, heavy steel rails, more rigid cars and interchange of traffic have permitted an era of rapid transit of heavy capacity freight cars with time schedules almost equal to that

of express trains. Daily runs averaging thirty miles per hour, including stops, with an occasional burst of speed as high as fifty to sixty miles per hour, to maintain the high average rate is not uncommon.

The thirty ton car, introduced in 1885, was the heaviest capacity car on any railroad during the time of the World's Columbian Exposition at Chicago, in 1892. It was strongly argued at that time that the wheel load of 11,000 lbs., which was required under cars of 30 ton capacity was the maximum that could be carried on a 33 ins. diameter wheel, because the area contact between the wheel and rail being so small, any greater load would

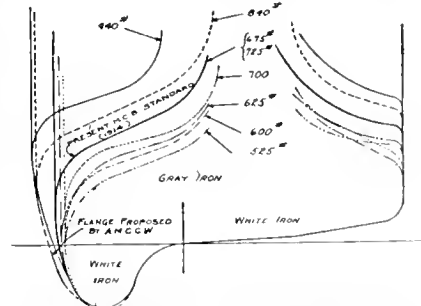

DEVELOPMENT OF FLANGE AND TREAD OF THE CHILLED IRON WHEEL UNDER GROWING REQUIREMENTS.

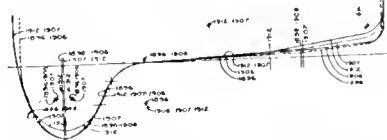

CHANGES THAT HAVE BEEN MADE IN THE M.C.B. CONTOUR OF FLANGE AND TREAD, FIG. 6.

cause a permanent injury to both wheel and rail by reason of the fact that the elastic limit in the metal would be exceeded, resulting in dents in the rail and flat spots in the wheel tread.

Not only was 11,000 lbs. per wheel considered the maximum wheel load, but there was a good deal of doubt expressed by the foremost engineers as to whether this load was not in excess of good practice. The introduction of the 30-ton car was very rapid on all railroads.

regarding the maximum wheel load, cars of 40 ton capacity were soon tried out and found to be satisfactory and almost immediately thereafter the 50 ton car was developed for the coal carrying trade and found to be so satisfactory that cars of lighter capacity ceased to be built for this service. The 700 lbs. wheel was used under 50 ton cars and recommended as standard in 1904, by the M. C. B. Assn., but afterwards, upon the recommendation of our association, was modified to 725 lbs., and made standard in the year 1909. This design is shown in Fig. 4.

It will be noticed that in 1904, the first wheel made standard for the 50 ton cars weighed 700 lbs. In 1909 we succeeded in getting the weight increased 25 lbs. During the time intervening, a new wheel was introduced of the rolled steel type, and notwithstanding the alleged superiority of metal, the steel wheel substituted for the 700 lb. chilled iron wheel, weighed a minimum of 750 lbs. Fig. 5 is a composite drawing showing the contours of the early 525 lbs. wheel, and the present standard 625 lbs. and 725 lbs. wheels.

The present indications are that the 50 ton car is likely to be superseded in the very near future by the 70-ton car for carrying such commodities as coal, iron ore, etc. Cars of 70 ton capacity have already proven successful from every standpoint, and are being made in comparatively large numbers at the present time. The wheel proposed for this service by the Association of Manufacturers of Chilled Car Wheels is shown in Fig. 10.

The marvellous increase since the year 1875 in the capacity of cars and the tremendous tonnage hauled has called for an increase in the weight of the car structure, from 18,000 lbs. to 65,000 lbs. or 260 per cent. increase. There has also been an increase in the weight of rail from 50 lbs. to 125 lbs., or 150 per cent. increase. The axle has increased from 350 lbs. to 1,070 lbs., or 200 per cent. increase; and the weight of the wheel from 525 lbs. to 850 lbs., or 60 per cent. increase. All of these increases are shown in the following table:

Capacity, lbs.	20,000	60,000	100,000	140,000
Per cent. of increase		200	400	600
Average wt. of cars, lbs.	18,000	30,000	62,000	50,000
Per cent. of increase		66	133	178
Weight of h'y. cars, lbs.	18,000	48,000	64,000	65,000
Per cent. of increase		166	255	261
Weight of axle, lbs.	350	550	870	1,060
Per cent. of increase		57	149	203
Weight of h'y. of car, lbs.	12,100	23,000	32,000	39,000
Per cent. of increase		88	165	215
Weight of wheel, lbs.	525	625	725	850
Per cent. of increase		19	38	62

A chilled iron wheel weighing 600 lbs. was used under cars of this capacity and was recommended as standard in 1904 by the Master Car Builders' Association. It was later modified and the weight increased to 625 lbs. in the year 1909, upon the recommendation of our association. This standard is shown in Fig. 3, which represents the present M. C. B. standard.

Notwithstanding the doubt expressed

It will be noted that the percentage of increase in the wheel is much less than for any other part of the car, and while the carrying capacity has increased from 10 to 70 tons, or 600 per cent., the weight of the heaviest M. C. B. standard wheel has increased only 38 per cent. This is a wonderful record for the performance of the wheel under adverse circumstances, when it is considered that not only has the capa-

city been increased but the speeds at which trains are operated have been increased 500 per cent. The ton miles per annum of the present 70 ton car is approximately twenty times that of the 10 ton car, which indicates the greater service given by the present wheel than

change in track clearance is required. There can, therefore, be no objection from a track standpoint of making a liberal increase in the present flange thickness and we have received the approval of our plan from a special committee, who were appointed for the pur-

flange. There are approximately one-half million wheels running to-day with flanges increased one-eighth inch in thickness, and which have a throat to throat dimension of 4 ft. 7⁷/₈ ins.

Relation of Wheel to Service Conditions

In the year of 1909, the Association of Manufacturers of Chilled Car Wheels made a study of the heat stresses developed in the wheel through brake application, and issued a pamphlet which was widely circulated, entitled the "Relation of Cast Iron Wheels to Service Conditions." It was our purpose to call the attention of the railroads to the fact that under present conditions of operation in some classes of service where high braking power is encountered, that the wheel was being subjected to uses for which it was not designed. This was particularly noticeable in cars of heavy tare weight. Under the thirty ton class of cars, one wheel weighing 625 pounds was introduced, in the year 1909, for use under any car whose gross load was 112,000 lbs., and the variation in the light weight of the cars in the thirty ton class is to-day from 23,000 lbs. to 53,000 lbs., approximately.

Inasmuch as the cars are braked at 60 per cent. of their light weight it was shown that one car of 46,000 lbs. light weight was subjected to twice the brake pressure of other cars weighing 23,000 lbs. in the same class of thirty ton cars and in the same train, and in consequence many wheels were subjected to heat stresses in excess of that for which they were originally designed. The result was that many wheels were removed on account of cracked plates, due to the excessive heating of the wheel on account of the strain in the plates, because the plates of the wheel were not designed or intended for one hundred per cent. increased duty. A cracked plate wheel should be rare if the plates of the wheel

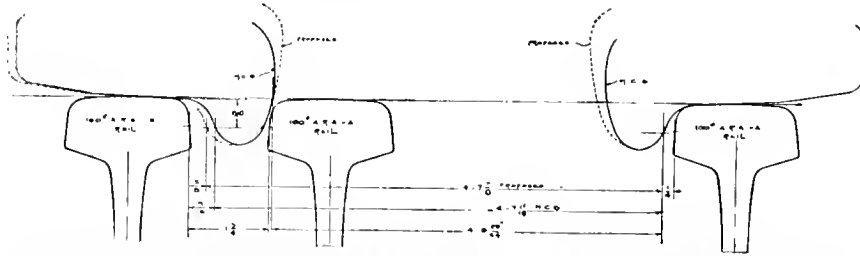

FIG. 7. RELATIVE POSITIONS OF M.C.B. AND PROPOSED FLANGES WITH REFERENCE TO GUARD RAIL WHEN ONE FLANGE IS AGAINST THE RUNNING RAIL.

was secured from any wheel during the pioneer days. It also plainly shows that the mere comparison of mileage is of no value whatever unless the load carried is taken into consideration.

The Flange

While the chilled iron wheel has always met increased requirements by reason of the rapid increases in the capacity of the cars, there is one part of the wheel that has received scant consideration, and that is the flange. The drawing, Fig. 6, will indicate all the changes that have been made since the wheel was first introduced, in the year 1850.

During all the remarkable railroad development, one dimension in track structure has remained constant. The space between the running rail and guard rail has remained fixed as one and three-quarter inches.

Chilled iron wheel manufacturers have been trying for years to secure a stronger flange and have demonstrated the fact that three-sixteenths of an inch can be added to the thickness of the present M. C. B. flange, compensation for the increase being made in mounting each wheel three-thirty-seconds of an inch

pose of investigation through the American Railway Engineering Association.

Under the 10 ton car, whose weight was about equal to its capacity, the load carried per wheel was approximately 5,000 lbs., which would require about 4,000 lbs. flange pressure to change the direction of the truck in engaging curves.

Under the 70 ton car, the load per wheel has increased to 25,000 lbs., which requires almost 20,000 lbs. flange pressure to change the direction of the truck, therefore the flange thrust has increased 400 per cent. on account of the increased load, which is further augmented by the high speed of modern freight trains. Under present conditions of operation, considering the increased load and speed the thrust on the flange, including impact, is at least ten times greater than under the old 10 ton car, and by consulting the chart showing the changes that have been made in the flange, it must be apparent that the increased duty has not been provided for.

Figure 7 shows the relative position of the M. C. B. flange and the proposed flange, recommended by our association

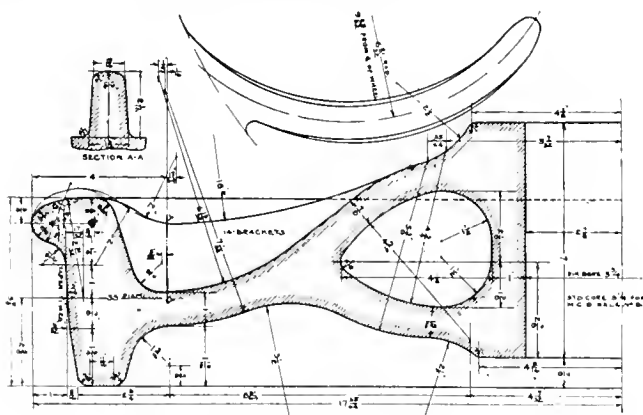

FIG. 8. WHEEL OF 675 LBS. PROPOSED BY THE A.M.C.C.W. FOR ALL CARS OF LESS THAN 40 TONS CAPACITY.

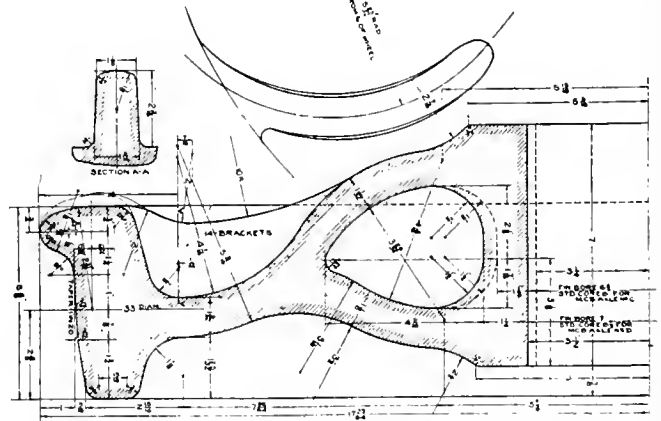

FIG. 9. WHEEL OF 750 LBS. PROPOSED BY THE A.M.C.C.W. FOR ALL CARS OF 40 TO 55 TONS CAPACITY.

closer to the rail and still maintain the Master Car Builders' standard throat to back the flange dimension of 4 ft. 6 29-64 ins. This insures that the relation of the back of the flange to guard rail remains the same as at present and no

with reference to guard rail, and it will be seen that the flange can be increased three-sixteenths of an inch when mounted as proposed, and there can be no greater impact blow against the guard rail than with the present M. C. B.

are designed for the maximum condition of service.

The following table will explain the recommendation of the manufacturers with reference to plate thickness, and while these recommendations were made

in the year of 1909, and based on 70 per cent. of the light weight of the car, the conditions confronting the manufacturers have not yet been changed.

plate developed while pressing on the axle. The ratio between these stresses developed in the seventy-ton car, as compared to the ten-ton car, is much greater

wheels of 675 lbs., 750 lbs., and 850 lbs. respectively, with flange reinforcement of 3-16 in. for 30, 50, and 70-ton cars, would in a great measure solve our present troubles and our recommendations would be:

- 675 lb. wheel for cars having a maximum gross load of. 112,000 lbs.
 - 750 lb. wheel for cars having a maximum gross load of. 161,000 lbs.
 - 850 lb. wheel for cars having a maximum gross load of. 210,000 lbs.
- drawings of which are shown in Figs. 8, 9 and 10 respectively.

Cost

I know of no railway material sold that is so necessary for operation, that comprehends so low an initial investment to the railway, as the chilled iron wheel. The eight million tons of chilled iron wheels running to-day possess a higher relative market value when worn out, based upon their first cost, than is usual with other commodities purchased by the railroads. Worn out chilled iron wheels are as staple as sugar, and are worth about sixty per cent. of the original selling price; therefore, if you purchase wheels at \$25 per ton, the manufacturers will immediately accept in part payment for the new wheels, old worn out wheels at approximately \$15 per ton.

Hundreds of thousands of chilled iron wheels have been sold at a differential of \$10 per ton, which represents the difference between the original selling price and the scrap value of the old worn out wheels, and this \$10 per ton differential represents the cost of reconvertng the old wheel into a new one, plus the necessary labor, plus the price of the

THICKNESS OF PLATES REQUIRED IN RAILROAD CAST IRON WHEELS TO WHICH BRAKES ARE APPLIED

Maximum Gross Load on 8 wheels	Thickness of plates required in each wheel to safely carry the load	Total breaking power of car	Thickness of plate to be added to take care of temp stresses.	Required Thickness of Thread
Pounds	Inches	Pounds	Inches	Inches
40,000	.36	12,500	.16	
50,000	.41	15,000	.19	
60,000	.45	17,500	.22	1.50
70,000	.48	20,000	.25	
80,000	.52	22,500	.28	1.62
90,000	.55	25,000	.31	
100,000	.58	27,500	.34	1.75
110,000	.60	30,000	.37	
120,000	.63	32,500	.41	1.87
130,000	.65	35,000	.44	
140,000	.68	37,500	.47	2.00
150,000	.71	40,000	.50	
160,000	.73	42,500	.53	2.12
170,000	.75	45,000	.55	
180,000	.77	47,500	.59	2.25
190,000	.79	50,000	.62	
200,000	.81	52,500	.66	2.37
210,000	.84	55,000	.69	
220,000	.86	57,500	.72	2.50
230,000	.87	60,000	.75	
240,000	.89	62,500	.78	
250,000	.91	65,000	.81	2.50

WEIGHTS OF VARIOUS DIAMETER OF WHEELS WITH GIVEN THICKNESS OF PLATES.

Thickness of plates in inches	Weight of Wheels					
	36" diam.	33" diam.	30" diam.	28" diam.	26" diam.	24" diam.
.62	640	550	480	440	390	350
.68	665	575	500	455	405	360
.75	690	600	525	470	420	375
.81	715	625	550	485	435	390
.87	740	650	575	500	450	405
.93	770	675	600	520	465	420
1.00	800	700	620	540	480	435
1.06	830	725	640	560	495	450
1.12	860	750	660	580	510	460
1.18	890	775	680	600	525	470
1.25	920	800	700	620	540	
1.31	950	825	720	640		
1.37	980	850	740	660		
1.43	1010	875	760			
1.50	1040	900				

Stress Tests

The University of Illinois, under the direction of our consulting engineer, F. K. Vial, have been conducting a series of tests for the purpose of ascertaining the magnitude of stresses to which the wheel is subjected in pressing it on to the axle and under various service conditions. These are enumerated as follows:

First—When a wheel is pressed on an axle, a compressive stress is developed radially and a tensile stress circumferentially. These stresses are of large proportion and extend all the way from the hub to the tread.

Second—The plate must carry the load, which produces a combination of stresses resulting in a wheel slightly elliptical.

Third—On descending grades the heat generated by the brake shoe, which is a factor of load, grade and speed, causes a tensile stress in a radial direction in opposition to the compressive stress which was developed while pressing the wheel on the axle.

Fourth—The heavy flange thrust causes a bending action in the plate which intensifies the tensile stress developed by the heat in the front plate and the compressive stress in the back

than that indicated by the mere increase in carrying capacity. The heaviest stress developed is probably that caused by the sudden rise in the temperature of the tread of the wheel from brake shoe application on descending grades. If we assume that trains are now operated at double the velocity they were forty years ago and the load on the wheels five times as great, there will be ten times the heat generated per unit of time on the tread of the present wheel, as compared to the wheel under the ten-ton car. Also the flange thrust being from five to ten times greater indicates that we have ten times the force to contend with that we formerly had.

Chilled Car Wheel Manufacturers' Recommendations

The information obtained would indicate that in order to design a wheel that will fit a given condition of service, it requires a thorough understanding of the intensity of the stress in each part of the wheel and the relation of the stresses to service conditions. Our association believes that due to the general conditions confronting us to-day, and considering the safety factor of operation, that three designs of

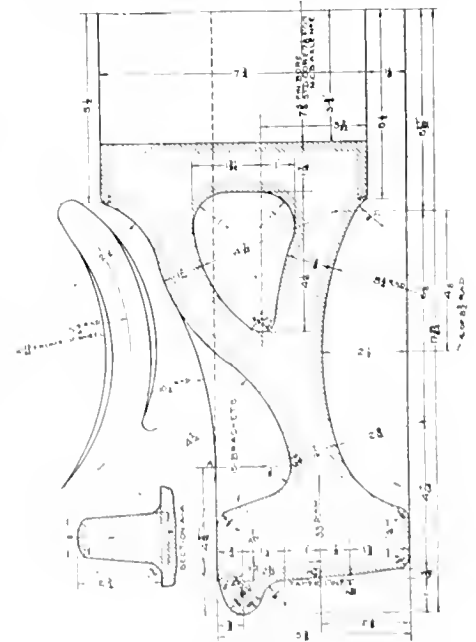

FIG. 10. WHEEL OF 850 LBS. PROPOSED BY THE AM.C.C.W. FOR ALL CARS OF 60 TO 70 TONS CAPACITY.

new material and the profit of the manufacturer. Special wheels are purchased by many railroads at a higher differential than \$10 per ton, and some foundries, located in remote parts of the

country far from the raw materials, such as coke and pig iron, must receive a higher price. The profit on a chilled iron wheel is so low that a fifteen cent freight rate will often absorb the profit on the wheel.

Contracts with railways provide for an equal exchange of tonnage of old wheels, and it is not necessary to exchange the identical worn out wheels to the manufacturer. Any chilled iron wheel, no matter where or by whom made, is accepted in part payment for the new wheels, and wheels made in Canada may find their way into the exchange market of Texas, and wheels made in California are exchanged in Massachusetts or vice versa, and as there are fifty foundries conveniently located throughout the United States and Canada which are accepting all makes of wheels in exchange, a ready and economical solution of the old wheel problem is provided. The commonest kind of castings, such as sash weights, which require no skill to manufacture, and which have no duty to perform except as counterweights, cannot be purchased as cheaply as chilled iron wheels.

About thirty per cent. of all wheels sold are removed by foreign lines and the price paid for these removals is fixed by the printed interchange rules of the Master Car Builders' Association, as follows:

	Chilled iron.	Steel.
New value, each	\$9.00	\$19.50
Scrap value, each	4.75	4.50
Net cost	\$4.25	\$15.00
Cost of removing from and replacing in trucks, per pair \$2.25, each ..	1.12	1.12
Cost under car, each..	\$5.37	\$16.12
Cost of two turnings..		3.25
Total cost of wheel service, each	\$5.37	\$19.37

It will be observed that the total cost for wheel service for other types of wheels is about four times that of the chilled iron wheels, and upon this basis of comparison any substitute must yield four times the mileage or time service in order to equalize the cost. As the Master Car Builders fix the price of removals on 30 per cent. of your equipment, it must follow that the same relative basis of cost must apply on the 70 per cent. of removals on your own lines.

Chilled iron wheels sold at a differential of \$10 per ton makes the net cost of the three Master Car Builders' standards as follows:

625 pounds M.C.B. wheel for 30-ton ears	\$3.12
675 pounds M.C.B. wheel for 40-ton ears	3.37
725 pounds M.C.B. wheel for 50-ton ears	3.62

All chilled iron wheels, unlike other types, are guaranteed for a minimum service, and the usual guarantee in the States is:

625 pounds M.C.B. wheel for 30-ton ears	6 years
---	---------

675 pounds M.C.B. wheel for 40-ton ears	5 "
725 pounds M.C.B. wheel for 50-ton ears	4 "

Should any of these wheels fail in service through the fault of the manufacturer a new wheel is supplied without any cost to the user.

Maximum net cost of 625 lb.

M.C.B. wheel gtd. 6 yrs.. .52c per year

Maximum net cost of 675 lb.

M.C.B. wheel gtd. 5 yrs.. .67c " "

Maximum net cost of 725 lb.

M.C.B. wheel gtd. 4 yrs.. .90c " "

Any wheel that is sold for \$20 will cost the railroad, in interest charges alone (figured at 5 per cent. per annum), more than the renewal charges of the chilled iron wheel, because while the guaranteed net cost to the railroads is based upon six, five and four years' service respectively, the actual service is often twice as much. During the two years last past, the price of all commodities have reached their highest figures. Nevertheless, the price of the chilled iron ear wheel has practically remained constant. Based upon the annual renewals of 2,500,000 wheels any other substitute at a price of \$20 per wheel will cost the railroads \$50,000,000 initial investment the first year.

NO APPEALS FROM BUSINESS TAX

NOT a single appeal from the business tax, imposed last session, has so far been received by the Finance Department, Ottawa. This is an entirely unexpected state of affairs, arrangements having been made for the appointment of Boards in the various districts before which the appeals expected to be made, could be heard. So far however no need has been found for them. That this is so, is attributed by the Finance Department, largely to the patriotic spirit shown by Canadian business men in remitting the assessments.

The business tax collections during the present fiscal year, it is estimated, have produced over the ten million dollars expected. The tax collected was on the basis of 1914-15 profits which were, as a rule, small owing to the disorganization of business produced by the first outbreak of war. Next year's results will be much greater. The tax will not be operative after the present year but collections will continue to be made for a year after that.

B.C. LUMBER OUTPUT INCREASE

WHILE the preliminary figures have not yet been compiled, it is stated that the value of the lumber cut for the Province of British Columbia in 1916 will show a satisfactory increase over that of the previous year, when the value was put at \$29,150,000. The demand for lumber during the past year showed an improvement, and prices generally were higher than the year before. The best previous year was 1913, when the value of the cut was \$33,500,000. It is pre-

dicted that this year's value will be well up to this latter figure. A feature of last year's lumber business has been the increase in shipments to Ontario, where the late Government carried on an aggressive campaign to popularize the British Columbia product. The demand there has resulted in doubling shipments from this Province, especially for floorings, paneling, mouldings, etc. The fact that these shipments have been made by rail indicate the popularity which the British Columbia products have secured in the East.

RAILWAY FACILITIES INADEQUATE

THE Canadian Bank of Commerce, in its commercial letter for February, contends that the railway connections between Canada and the United States coal fields and industrial centres are inadequate. Upon this topic it says: "During January, Canadian railways found great difficulty in handling satisfactorily the unusually heavy volume of traffic which has originated, partly from the continued industrial activity and partly from an unusually heavy movement of field products. The outstanding factor in maintaining this state of affairs is, of course, the urgency of the demand for our agricultural products and for munitions of war. Large quantities of partially manufactured materials are being imported to enable Canadian factories to meet the latter demand as well as that for goods for the home market.

Activity so general, especially in the industrial centres, has created an abnormal demand for additional power and fuel. In that part of Ontario served by the electric current generated at Niagara Falls, there is a continuously increasing demand for power, and special arrangements have had to be made through Government agencies to provide for the increase. Many industrial establishments are being inconvenienced through lack of coke and steam coal. These facts serve to show the character of the prevailing industrial activity, and, taken in conjunction with the difficulty of obtaining deliveries in reasonable time, indicate the inadequacy of existing railway connections with the United States coal fields and industrial centres. The congestion at Buffalo and Detroit, where so much traffic enters Canada, is a contributory cause of the difficulty in Ontario."

Tin-Plate Shortage.—Officials of the Department of Trade and Commerce at Ottawa state that there is a shortage of tin-plate in Canada. This is due to lower production in England, and to the shipping situation. The department thinks that steps should be taken to collect all the tin available, such as tin boxes and cans, in order that it may be used over again. It is believed that if some systematic plan of collection is adopted the shortage of the tin-plate will be largely made up.

EDITORIAL CORRESPONDENCE

Embracing the Further Discussion of Previously Published Articles, Inquiries for General Information, Observations and Suggestions—Your Co-operation is Invited

SPECIAL DESIGN HEADSTOCK SPINDLE

By J. H. R.

RIGIDITY in machine tools and auxiliary equipment is undoubtedly one of the chief essentials in the successful manufacture of munitions. Machining a shell requires special facilities for rapid and economical production. As in most other classes of work, the setting generally occupies much more time than the actual tooling operations, and it is this feature of shell making that has probably received greater attention than some of the other details. Standard lathe designs were early found to be unsuited for rapid handling of shells, the chucking problem being one of the chief factors that led to the radical departures from precedent with which all of us are now more or less familiar. Many machines, while differing greatly from standard in several respects, still require special chucks or attachments for holding the shells. In a large number of cases lathes had to be fitted with special steady-heads to support the outer end of the shell or fixture, so as to prevent the overhang from affecting the alignment, and also to avoid vibration under the heavy cuts required.

Manufacturers, however, are rapidly realizing the advantages of maximum rigidity, and machines are now being designed so that the spindle is constructed sufficiently large to contain the chuck and operating mechanism, the shell being practically held within the main front bearing of the headstock. The accompanying cut illustrates the section of spindle of a special machine recently designed by Darling Bros., of Montreal, for band turning and similar operations on 4.5-inch shells. The chuck jaws A are operated by the spider B, the thrust plate C retaining jaws in position. The shaft D connects the spider with the piston E of the air cylinder F. The pulley G lined with the bronze bush H rides loose on the spindle, which is driven by the action of the clutch I feathered to the spindle. The clutch,

which is fitted with wooden blocks, is operated by the dogs K held in the adjustable collar L, the pressure bolts M

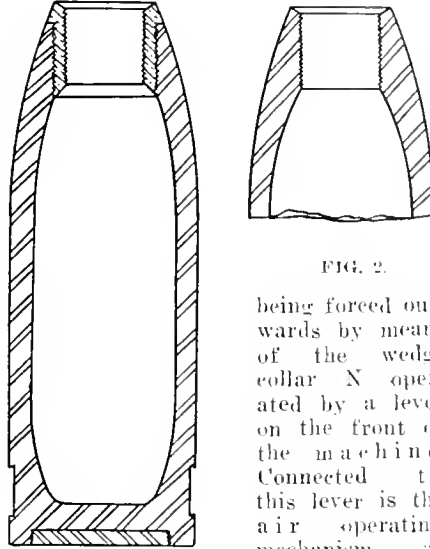

FIG. 1.

FIG. 2.

being forced outwards by means of the wedge collar N operated by a lever on the front of the machine. Connected to this lever is the air operating mechanism, so that the one movement operates the air chuck, and also starts or stops the machine. The clutch is released by the action of the pin P forced out by the spring O, a steel washer preventing the pins from cutting into the cast iron clutch. The spring R forces back the piston when the air is released. Adjustable thrust collars are provided at the back end of the rear bearing.

ates the air chuck, and also starts or stops the machine. The clutch is released by the action of the pin P forced out by the spring O, a steel washer preventing the pins from cutting into the cast iron clutch. The spring R forces back the piston when the air is released. Adjustable thrust collars are provided at the back end of the rear bearing.

NOSING 4.5-IN. MARK VII. HIGH EXPLOSIVE SHELLS

By A. F. W.

ALTHOUGH a great deal has been written concerning the various machining operations on the different types of shells now being manufactured, very little information has so far been made available regarding the nosing-in operation, and the following remarks will doubtless be of interest to many readers at this time.

The 4.5 H.E. shells were the first shells of this type to be made with a formed nose, the design known as Mark V., see Fig. 1, having a brass socket fitted at first, which, however, was expensive, the design being afterwards changed so as to have the nose completely formed to size, integral with the shell body, as shown in Fig. 2, this being latterly the standard design of Mark V. shell.

The most common method of forming the nose is by pressing the shell forging into a suitably shaped die, mounted in a hydraulic press of the type shown in

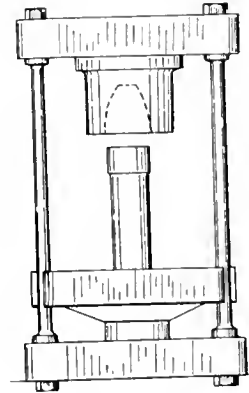
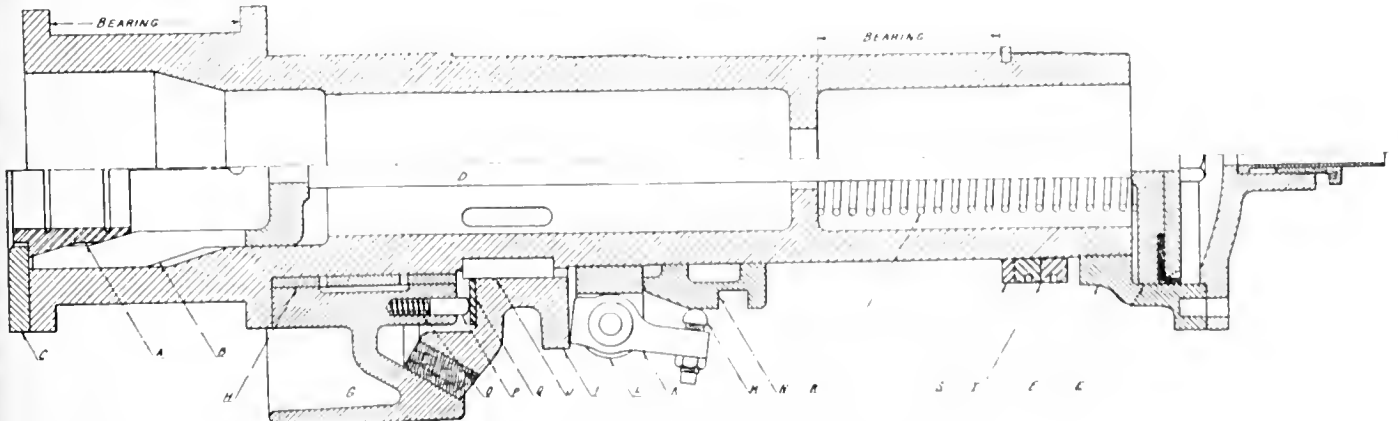

FIG. 3.

Fig. 3. Bulldozers, equipped with similar dies, have been used by firms who already had such machines installed for other purposes, and power hammers, equipped with half dies, as illustrated in Fig. 4, have been employed for swaging the nose and have produced good work. In most cases the shells are heated in some kind of oil furnace capable of heating about five shells at once.

All of these foregoing methods yielded equally good results on the Mark V. shell, as the nose was easily formed, the limits of length of thread at the nose being large enough, so that if one shell was heated a little higher than usual, or the die happened to be of slightly different shape, or the forging were turned a little over or under size, it was still pos-



SPINDLE ASSEMBLY FOR BAND TURNING MACHINE.

sible to produce a correctly machined shell within the specification requirements.

Mark VII. Design

The Mark V. shell however, did not

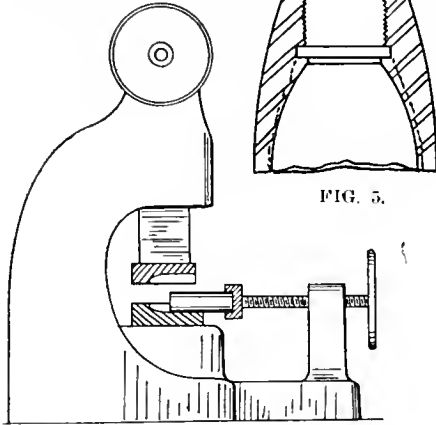

FIG. 4.

give entire satisfaction in use, hence our "misfortune" to be called on to make Mark VII. design (see Fig. 5.) At first sight the change seemed slight and innocent enough, the apparent difference from Mark V. being very small; yet it proved to be much more difficult than appeared, and many shell makers now changing over to this design are having their troubles. With the Mark V. design, the closing in the end thickened up the material just sufficiently to form the nose satisfactorily, but on comparing the two designs, as in Fig. 5, it will be seen that more metal has to be put into the nose for Mark VII. design. To do this satisfactorily, the shell must be upset, and the use of a hydraulic press, in the writer's experience, is the most satisfactory method of insuring uniform work; the bulldozer, unless exceptionally heavy, would not be suitable owing to the extra pressure necessary, while the swaging effect of the hammer does not upset the metal sufficiently.

Rough Turned Sizes

In Fig. 6 is shown a forging rough turned to dimensions for the Mark V.

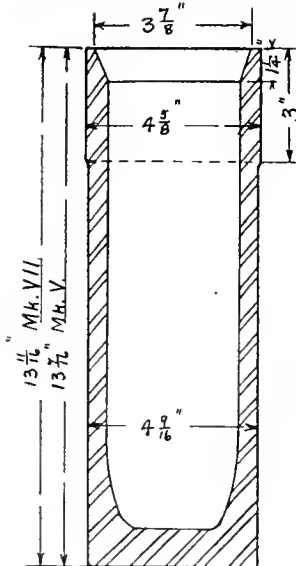

FIG. 6.

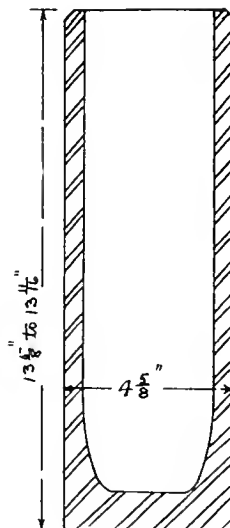

FIG. 7.

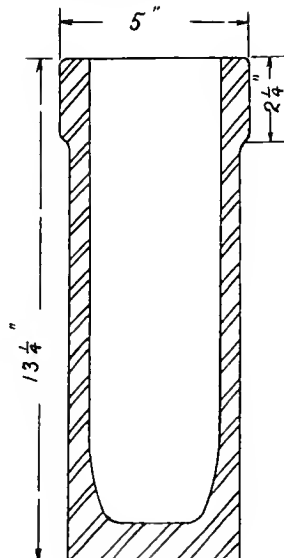

FIG. 8.

shell, and the same design made 1/4 in. longer gives a good Mark VII. nose, with rather an excess of metal to remove. The form shown in Fig. 7 will also make a good Mark VII. nose, but great care must be taken in heating, as there is very little extra metal, and consequently less to machine off inside after forging.

A forging roughed to the dimensions given in Fig. 8 can be safely nosed-in with a hammer, but the standard forgings are not large enough to machine up to this size, and special forgings have to be obtained; the hammer, however, is being used by those firms who had them previously installed for the Mark V shell, but many forgings are spoiled, and have to be reclaimed by socketing when the fuse seat does not clean up.

Heating the Nose

When nosing with a press, the depth of nose inside the shell depends entirely on the temperature and the distance from the end to which the shell is heated, always provided that there is sufficient metal in the forging to make the nose. For instance, take forging, Fig. 6, and heat it to a good white heat about

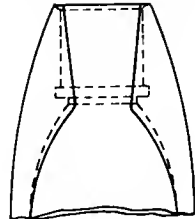

FIG. 9.

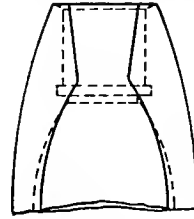

FIG. 10.

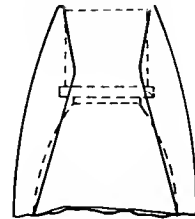

FIG. 11.

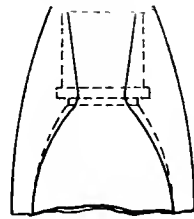

FIG. 12.

4 1/2 in. down and a section will be obtained, as shown in Fig. 9, which is of no use. A forging of this shape, heated about 3 in. down, will yield the section

shown in Fig. 10, which has lots of metal in the right place.

Again, take forging roughed, as in Fig. 7, and heat it to a good white soaking heat about 2 3/4 in. down, and an even better section will be obtained, Fig. 11, with less metal to remove from the bore. Care must be taken when heating this design, because if the heat be allowed to

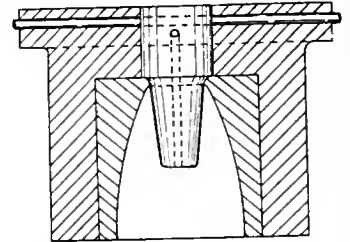

FIG. 13.

travel beyond 3 in. from the end, the section shown in Fig. 12 will result.

Use of Pin in Die

To get any of these sections, a pin must be used in the die to limit the closing of the hole and cause the die to exert an upsetting effect on the heated portion of the walls; the use of this pin was not necessary with Mark V. shell. A die-holder and pin, as designed and used by the writer, are shown in Fig. 13. The die-holder is of east iron, and the die itself of special chilled east iron, the pin being of soft steel case-hardened. The chilled die will usually nose from 10,000 to 15,000 Mark VII. shells, although a die of this type has nosed as many as 27,000 Mark V. shells, and when removed was in good condition, which is pretty conclusive evidence of its superiority.

Pin Dimensions

It is necessary to change the pin about every 5,000 shells, and for this reason it should be made as simple as possible, and easy to remove without disturbing the die. The dimensions of the pin are given in Fig. 14, the hole A being made to coincide with a hole in the holder, which is coupled up to the air line which supplies pressure to force the shell out of the die after pressing. The inside of the die and also the pin should be painted over every impression with a mixture of graphite and water mixed to a paste, which prolongs the life of the die and produces better work.

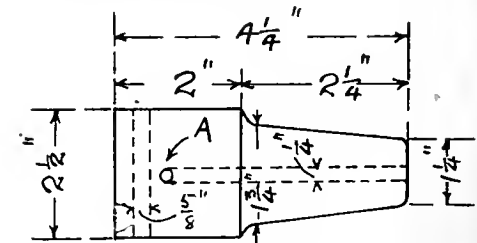

FIG. 14.

It is well to have a number of pins made up, as, after pressing from 3,000 to 5,000 shells, the pin becomes a little rough and should be removed and another inserted; the old pin can be quite well ground up smooth and used repeatedly, or else softened, filed up, re-hardened and polished.

SAFE OXY-ACETYLENE WELDING EQUIPMENT

WITHIN the last few years oxygen and acetylene gas in combination have come into general use both for welding and for cutting metals. The high temperature of the flame (6,000 degs. Fah., or more), and the oxidizing effect that is obtained when the burner is supplied with an excess of oxygen, make it possible to cut heavy steel objects with great rapidity, and under circumstances where it would be extremely difficult to do the same work by any other means. The oxy-acetylene torch is also capable of producing excellent welds, when it is operated by an expert workman, and repairs can be quickly and cheaply made by it, where otherwise the necessity for procuring new parts, or perhaps manufacturing them, would cause expensive delays.

Nowadays an oxy-acetylene welding outfit is to be found in nearly every large modern machine shop and repair shop. The equipment comprises an acetylene gas generator (or one or more tanks of compressed acetylene gas), together with cylinders of compressed oxygen, and suitable torches for welding and cutting. In addition, there must be effective regulating devices to furnish a proper mixture of oxygen and gas to the torch, at a suitable pressure, and special hose must also be provided to transmit the gases from the generator or tank to the tip of the torch where they are mixed.

Generator Feature

In shops where a large amount of welding is constantly being done, the acetylene gas is often manufactured on the premises, by bringing calcium carbide in contact with water in a suitable generator. Nearly all generators now in use are automatic in action, the gas-producing operation being controlled by a "bell" in which the gas is stored, and which, by alternately rising and falling as the acetylene is generated or drawn off, starts and cuts off the carbide feed.

Formerly, this generating process was attended by considerable danger, and a number of serious accidents occurred because attempts were made, often through inexperience, to generate the gas under pressure, and to store it in unsafe receptacles—such, for instance, as ordinary kitchen hot-water tanks. Pressure generators are little used at present, however, in connection with welding outfits, and if the dangers associated with them were generally understood it is doubtful if the authorities who have charge of such matters would permit them to be employed or operated under any circumstances. Acetylene gas should never, under any conditions, be generated under a pressure exceeding 15 pounds per square inch. Many generators are now manufactured which provide acetylene gas at a suitable pressure and which are equipped with appropriate safeguards. These have been approved by the National Board of Fire Underwriters, and a selection should be made from them when purchasing a self-generating welding outfit.

In many cases a portable welding or cutting outfit is necessary, because the work cannot be carried to a repair shop. Portable generators may be had, but it is often inconvenient to transport them to the scene of the operations, and therefore steel cylinders containing compressed acetylene are used.

Unabsorbed acetylene is highly explosive at a pressure of two atmospheres or more. We do not refer, here, to the possibility of exploding a mixture of acetylene and air by means of a flame or spark, but to the chemical instability of the gas itself. Acetylene is what chemists call an "endothermic" compound, and all compounds of this nature are more or less unstable, and liable to sudden explosive decomposition under certain circumstances—and accidents of this kind sometimes occur when it is not possible to guess what it was that precipitated the decomposition. Acetylene gas at ordinary atmospheric pressure and temperature does not spontaneously and explosively fly apart into its constituents, but when it is subjected to a considerable pressure, while in a wholly gaseous condition, it is likely to explode, as here indicated, without the slightest warning.

Acetylene Storage

Two French engineers, Claude and Hesse, made the exceedingly important discovery, however, that acetone has the remarkable property of absorbing about 25 times its volume of acetylene for each atmosphere of pressure at 60 degs. Fah., and that acetylene, when dissolved in this way, ceases to be spontaneously explosive, so that it may be stored in connection with acetone at pressures up to 250 pounds with comparative safety. To store acetylene safely, by this method, the metal container must first be completely filled with an approved porous substance of some kind, such as asbestos, leaving no voids where gas might accumulate even in small quantities. The porous filling must be constituted and arranged in such a way that it will not disintegrate nor change its position when wet, or when the cylinder is subjected to ordinary handling. Acetone is then introduced in quantity not exceeding 40 per cent. of the interior cubic capacity of the tank, after which the acetylene may be forced in until the desired pressure is reached. This pressure, however, must not exceed 250 lbs. per square inch, at a temperature of 70 degs. Fah. Persons who are not fully acquainted with the properties of acetylene should never undertake the compression of acetylene gas.

Handling Acetylene Gas Tanks

Certain precautions should be observed in the handling of charged acetylene gas tanks. In shops where a number of tanks are kept on hand constantly, it is advisable to provide special storage places for them. The cylinders should not be allowed to remain near stoves, furnaces, steam radiators, nor other sources of heat, nor should they be exposed unnecessarily to the direct rays of the sun, because the appli-

cation of heat is likely to increase the pressure in the cylinders, or (in extreme cases), to soften the fusible safety-plugs with which they are provided, so as to permit the gas to escape. These fusible plugs, which melt at a temperature of about 240 degs. Fah., are provided for the purpose of preventing explosions in case of fire, and tanks that are not fitted up with such plugs should not be used. Care should be taken to protect the discharge valves and safety devices against damage caused by heavy objects striking them, or by the tanks falling over.

Leaking cylinders must be condemned, and they should be set out in the open air as soon as discovered, and disposed of in such a manner as to effectively prevent any possibility of ignition of the gas, or of the mixture of gas and air that surrounds the leaking cylinders. No repairs should be attempted, but the charging station where the cylinders were filled should be notified concerning the condition of the cylinders. Open-flame lights should not be taken into confined spaces where there is any possibility of leakage of acetylene, because this gas is explosive when combined with air in widely varying proportions. Never use a lighted match, nor flame from any other source, for the purpose of detecting leaks in tanks. Leaks may be located by closing the discharge valves, applying soapy water to the outside of the suspected cylinders, and watching for the bubbling that the escaping gas produces.

Care of Oxygen Cylinders

Similar precautions are applicable to cylinders containing the compressed oxygen which is used in combination with acetylene gas to produce the welding and cutting flame. Oxygen is stored in metal cylinders, usually at a pressure of about 1,800 pounds per square inch, and it is easy to see that an explosion of one or more of these heavily-charged cylinders might result disastrously. Care should be taken to avoid mixing acetylene and oxygen at any time. A combination of the two gases under any conditions—such as might be effected, for example, by an interchange of hose or piping—may be highly explosive.

Oxygen cylinders should not be dropped or handled roughly in any other way, and they should be placed so that they cannot be overturned either by collision with some other object, or by the reaction due to the violent escape of their contents through the safety outlets with which they are provided. The valves, regulating devices, and other attachments should not be lubricated with oil or grease, because violent explosions may be caused by oil or grease coming in contact with compressed oxygen. In fact, a large proportion of the explosions and fires that have been caused by compressed oxygen, in recent years, have been demonstrably due to the use of grease or oil for lubricating purposes. Pure graphite should be used (unmixed with oil or grease), if any lubrication is needed. The discharge valves of oxygen tanks should be opened slowly, and spe-

cial care should be taken to avoid twisting or straining them by the use of hammers or improper wrenches.

In many cities there are regulations governing the storage of explosives and other dangerous substances, and in such cases charged cylinders containing compressed gas of any kind are often counted as "explosives," certain stipulations being made as to the number of cylinders that may be kept on hand. Attention is called to this fact in order to emphasize the importance of using care in storing and handling these cylinders. Like acetylene-gas cylinders, oxygen cylinders should never be allowed to remain near heating appliances, nor in any place where they might be exposed to sparks or flames.

Pressure Regulating Devices

Every welding and cutting equipment should include approved pressure-regulating devices for controlling the flow of acetylene and oxygen to the torches and to indicate the pressure in the tanks and also the working pressure. The torches and regulators used should be the best obtainable, and they should be constructed so that back-firing to the acetylene tank will be impossible. All hose connections and fittings of every kind should be of high quality, and should be kept in first-class condition in every respect.

To insure safety in the use of oxygen and acetylene gas for welding and cutting, no operators should be employed except men who have given satisfactory evidence that they are both competent and careful. Many accidents have resulted from the careless and unintelligent handling and operation of an equipment of this kind. Moreover, it should be remembered that the danger is by no means confined to accidents with the welding equipment itself, but that imperfect workmanship may result disastrously at some later time. When safety to life and property depend upon the strength of a certain welded joint, for example, it is highly important to have this joint made by a man of exceptional experience and intelligence.

Pure acetylene gas is now known to be comparatively non-poisonous, when inhaled in highly diluted form in small quantities, in consequence of slight leaks. The poisonous effects that have been observed in connection with it, and which were formerly attributable to the acetylene itself, are now known to be mainly due to the presence of impurities such as phosphoretted hydrogen. To avoid dangers of this kind as far as possible, the acetylene should be purchased of dealers who are prepared to furnish gas as free as possible from phosphorus and other objectionable contaminating substances.—Travellers Standard.



AIR CYLINDER EXPLOSION

AN alarming explosion of a compressed air cylinder worked in connection with a large gas engine has come to our notice, says *Vulcan*, and as so many of these high-pressure cylinders are now in use



LAMINATIONS IN EDGE OF FRACTURED COVER.

for starting purposes, the facts of the case are of interest.

It is sometimes asserted that air receivers are not liable to corrode or develop other defects on the inside, and, apparently, in accordance with this view many receivers are made without provision for internal examination. Experience with these vessels, however, shows that there is sufficient moisture in the air to cause serious corrosion, and that this is often aggravated by grease deposited from the compressor. For this

reason facilities should always be afforded in air cylinders for proper periodical cleaning and examination on the inside. The ends of such cylinders also should be of ample strength and well dished, unless otherwise strengthened by stays.

The cylinder in question was worked at a pressure of about 200 lbs. per square inch, and was made of iron plates about $\frac{3}{8}$ in. in thickness originally. The ends were nearly flat and the material, judging from the quality of the end which failed, was of very inferior quality. This plate was badly laminated for nearly its whole circumference and also corroded, and owing to the panting action which inevitably occurred with a circular flat plate under the working conditions, grooving was set up at the root of the flange attaching the end to the cylindrical body and eventually weakened the end to such an extent that it was blown out. The explosion was a violent one, the top end of the cylinder being thrown through the roof and into a field about 100 yards away. The windows of the engine house were damaged and the engine attendant had a narrow escape.

Air cylinders of this type intended to work at high pressures should be very carefully designed. The material should be of the best mild steel of ample strength, and for a diameter of 2 ft. the size of the cylinder in question, the ends should have been about $\frac{1}{2}$ in. thick and dished to a radius not greater than diameter of the receiver, which in the present instance would have been about 4 in. to 5 in., whereas the actual camber of the ends was only about $\frac{3}{4}$ in. Where flat or nearly flat ends are used the plates should be adequately stayed with bolts or other means. Should an air receiver be too small to fit an ordinary pressed steel manhole and cover, hand or side openings should be provided.

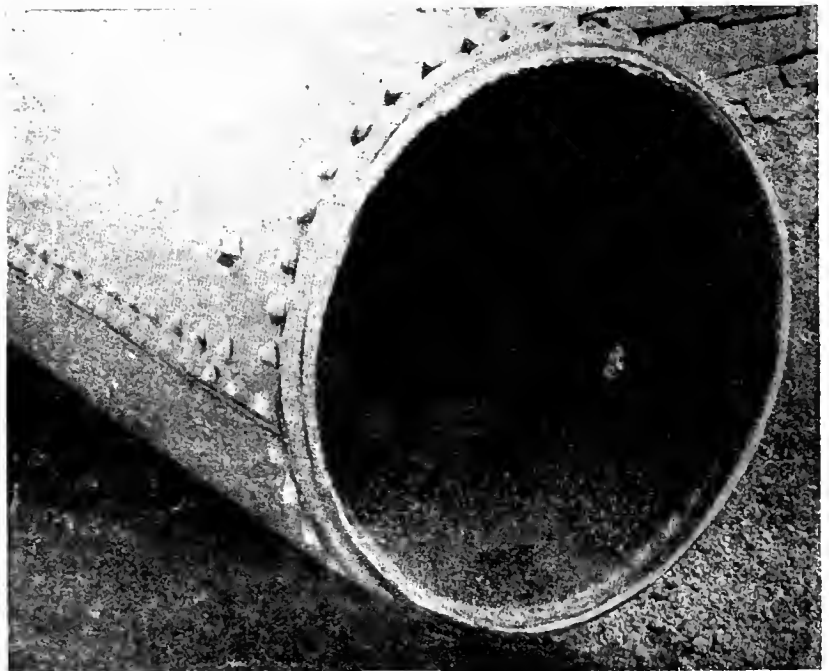

END OF AIR CYLINDER SHOWING FRACTURE.

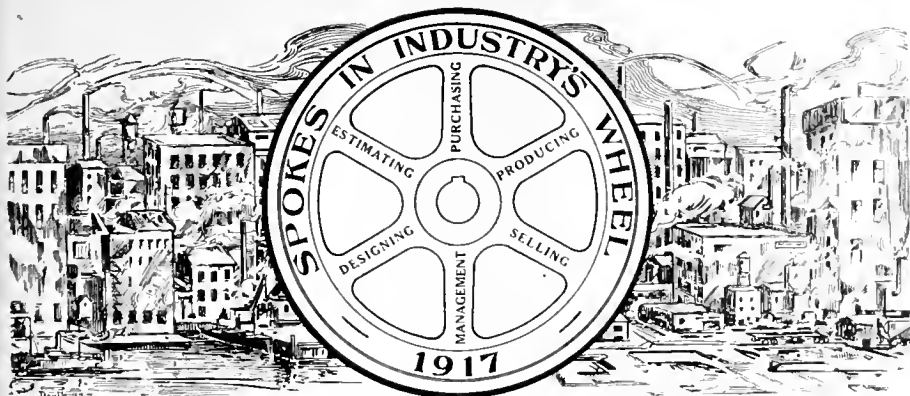

The constitution of industrial enterprise is largely departmental—"spokes in a wheel." This series of articles has for its object the featuring in a racy, interesting and instructive fashion, the training, experience and achievement of those who to-day are transmitting, effectively, energy in their capacity as "spokes in the wheels" of our metal-working establishments.

! HARRY ALTON WILSON

OF all the crafts represented in the activities of the war, that of engineering in its every aspect is dominant. The establishment of a munitions industry in Canada some two and a half years ago, and the extraordinary extent to which it has since been developed, serve of themselves to bring the truth of this statement quite forcibly home to us. Our metal-working plants, whether in their individual or corporate constituent, have, so to speak, found their feet, as a result of war-made opportunities thrust at them, which is equivalent to saying that they have become alive to their capacity for doing things, and, in consequence, have uncovered an expertness that was previously considered non-existent, and still less believed to be simply latent. Administrative business sense has been quickened and its outlook broadened, and what in this respect is applicable to the executive is equally so with regard to the employe-staff or operative, in his capacity of a Spoke in Industry's wheel.

Opportunities for the display of worth-while inventive genius such as the munitions industry has provided have been rare indeed; further, to the man with grit and balance, and who is at the same time well grounded in his profession, the prospects of achieving success as a result of embarking in manufacturing enterprise have at no time in our history been so alluring as during the past thirty months or so. Within the period indicated there has not only been witnessed a widespread and numerically large redistribution of employee appointments, in our previously established metal-working shops, but the interesting phenomenon, as well, of men hitherto under more or less direction, transferring themselves to positions of administration through their institution of new munitions manufacturing enterprises. Our "Spoke" this week, Harry Alton Wilson, superintendent, J. C. Wilson & Co., Belleville, Ont., is of the latter.

Alton, by which title he is addressed by those most intimate with him, was born at Glenora, Ont., April 17, 1890, of Canadian parents, and received his education at Picton Public School, Picton, Ont.; Highfield School, Hamilton, Ont., and Faculty of Applied Science, University of Toronto, of which he is a graduate in Mechanical Engineering. Previous to his university course and during and following same, he served as apprentice machinist in the shops of J. C. Wilson & Co., Glenora, Ont., in 1912 emerging as a full fledged mechanic



HARRY ALTON WILSON.

From February, 1912, until June, 1915, he set himself to acquire as wide a grasp of practical engineering experience as might be available in the time, hence we find him on the editorial staff of this journal for the first three months of the period. From May, 1912, until November, 1913, he was assistant sup-

erintendent with J. C. Wilson & Co., Glenora, following which he took a position with the Cadillac Motor Car Co., Detroit, as tool, jig and fixture designer. In July, 1914, he became editor in Montreal for the J. B. MacLean Publishing Co. mechanical papers, holding that position until June 1915, when he resigned to assume his present appointment with J. C. Wilson & Co.

Almost immediately thereafter, his firm started in to the machining of Mark V., 4.5 in. high explosive shell. In order, however, to secure not only more efficient production, but to eliminate transportation and labor inconveniences incidental to the shop's location at Glenora, it was deemed advisable to procure a more favorable site elsewhere and erect thereon an up-to-date plant. Belleville, Ont., was chosen. Not only has completion of same since been accomplished but first shipment of finished shells has already been made. Particulars of the new shops at Belleville are as follows: Machine shop, 150 ft. x 50 ft., steel frame and roof trusses, with walls of brick; blacksmith shop, 30 ft. x 30 ft.; woodworking shop of brick, two storeys, 22 ft. x 40 ft.; general storage building of stone, two storeys, 40 ft. x 80 ft. drive shed, frame construction, 30 ft. x 55 ft.; frame barn for horses; brick residence for watchman, and office building. The site, covering 3.6 acres, has a siding to the Canadian Northern Railroad, and constitutes ownership to a marine dock with natural rock slip, on which may be constructed later a marine railway. We are right in assuming that not only was the decision to establish a new plant, aside from that at Glenora for shellmaking, largely due to the influence of our "spoke," but the promptitude with which the project has been brought to the producing stage is equally to his credit.

Mr. Wilson is Conservative in politics and Methodist in religious creed. So far he has held no public offices, neither has he had honors or distinctions thrust upon him. One thing that all who know him well bear out—he has never been "too proud to work," and much of the success with which his shellmaking efforts are being crowned, is due to his ability to determine performance first of all, and, hence, later, direct it. On his own statement, he has never accomplished anything spectacular. In the realm of romance he has, however, played a not unimportant part, as we shall see later. His travels have been confined largely to visiting manufacturing plants in the New England States, Detroit, and Chicago; at the same time we have known him to visit the latter city on another and equally important mission.

Alton is married, the family residence being at 80 Commercial street, Belleville, Ont. His wedding to Miss Eleanor Winnifred Leeming, only daughter of Dr. John Leeming, vice-president, the American Medical Association of Chicago, took place on September 29, 1915. Needless to say he takes a pardonable pride in a little toddler at his home in the person of Margaret Eleanor Wilson.

He says nothing spectacular has been accomplished in his business career; but we have hinted at something romantic, and now take opportunity to disclose it. Dr. Leeming was cruising in his gasoline yacht on the Bay of Quinte, near Glenora, a few years ago, when misfortune overtook him in the shape of a broken flange on the exhaust manifold of his engine. He brought the damaged piece to the J. C. Wilson & Co. foundry, where a new flange was burned on, the manifold "dressed up" in keeping with the finish of the engine to which it belonged, and refitted in place. Our "Spoke" personally carried out the work, and to mark his appreciation of the service rendered, the doctor introduced Alton to the various members of his family aboard the yacht, and invited him to visit his summer home at Kingston, Ont. This he did in due course, and not infrequently thereafter, the upshot being that while apparently indiscreetly wrapt up in Dr. Leeming's five sons, their pranks and recreations, he and Miss Eleanor Winnifred Leeming, the only daughter and sister, got to know each other better, with the result already indicated.

"In the shell business I have had opportunity," says Mr. Wilson, "to study human nature from the viewpoint of a mechanic through the medium of the inexperienced shell operator. Young men are best, especially those who cultivate the faculty of observation and work steadily in the interests of their fellow workers and their firm, as well as in their own interest. The quality of observation is, however, the best possible asset. To learn the "why and wherefore" of performance is worth while for a young fellow to keep always in mind. When he learns why certain things are done in connection with his own particular job, he becomes particularly well fitted for a still better appointment. Reading technical journals—advertisements as well as editorial matter, familiarizing himself with drawings, blueprints, sketches, etc., are invaluable in the general preparation for a better job. In any shop, even the most trivial details demand attention, and their proper appreciation is a prime essential. Patience is a necessary virtue, as much so as perseverance. Big things are accomplished only by those who understand their make-up details and can employ them to advantage by combination."

3,231,000 WOMEN WORKING IN BRITAIN

ALMOST a million women — exactly 988,500—have entered all kinds of positions held by men before the war began, says a London, England, despatch, and of this number nearly all—exactly 933,000—were actually substituted for men called to the front or diverted to other war activities.

This is shown in a survey of the whole movement toward women labor since the outbreak of the war, made of-

ficially by the labor department, with data down to the last two months. It shows 3,231,000 women now employed in all branches of industry and commerce or about a million more than when the war began. It is this new million of women workers one sees at every turn, on the tramways and motorbuses taking fares, in the Government offices taking the place of the men clerks, in the hotels and restaurants as waiters and cashiers, in banks and business houses, and running cinemas, theatres, and the whole range of business activities.

Some Distribution Features

Just how far this has gone, the Government has now figured out. In banking and finance, for instance, there were only 9,500 women employed before the war; now the number has increased to 46,500. In Government departments, also, the women workers have increased from 66,000 to 133,000, displacing men in all but 3,000 cases. In industrial trades the increase of women has been greatest, reaching 393,000, of which 314,000 replaced men. Another very large increase of women is in the Government ammunition works, where there were 2,000 before the war, and 117,000 now. The Government figures give the entire 117,000 as directly replacing men.

In commercial occupations, clerks in stores, offices, etc., the increase of women is 268,000, of which 264,000 replaced men. In professional occupations, connected with law, medicine, magazine and newspaper work, etc., the increase of women is 15,000, of which all have replaced men. A curious fact is that each woman has replaced about two men in hotels, cinemas, theatres, etc., the increase of women being 16,000, and the displacement of men 30,000.

Transport Service

On buses, trams and various kinds of transport service, women have increased 41,000, the entire number replacing that number of men. Men teachers are also largely replaced; also men on municipal transport work, the total increase of women in this line being 34,000, of which 31,000 replaced men. In farm work many men have been drawn off for the war, but few women have replaced them. The men on farms, replaced by women is given as 20,000, while the number of women farm-workers is 80,000, and the increase since the war only 500. Women nurses have increased 34,000 since the war.

Summing up the substitution of women for men, the Government statement says there has been an increase of 150,000 since last July in the number of women directly replacing men. This shows a slight check in the rate of replacement. In some trades, like clothing and textiles, women workers have decreased, probably because they were able to get better wages in the many fields now opening to them. In October 40 per cent of the textile firms reported they were unable to get all the women they required so that while the supply of women workers has increased, the

demand is also increasing in many branches.

A Peace Time Problem

This replacement of men by women is introducing new elements in economic and social conditions which will have to be worked out when peace comes. The women are doing the men's work quite as well as the men, so that a new element of competition is introduced between the sexes. The women have advantage of possession of the million places, and it remains to be seen whether they will hold them, or whether there will be another displacement of women for men, when the million men come back. Many commercial houses have promised to take back the men, but whether this means displacing the women, or keeping both, it still uncertain. The labor unions are also apprehensive over the great swelling of women labor, as women workers are now about half the total strength of the unions, which are chiefly men's organizations, strong in politics and with representatives in Parliament and the Ministry. The competition between the sexes is being extended all along the economical, political and social lines.



ELECTRICAL MACHINERY OPENINGS IN CHILE

THE pre-war condition in the Chile market, in which the principal lines are electric-lighting materials and electric motors, was that, from Valparaiso to the north, the American-British manufactured article held sway, while, from and including Valparaiso to the south, German goods prevailed. The chief reason for this state of affairs is that, in the principal southern towns, the Germans own the power and light companies, and make their specifications so as to exclude British goods, and just as soon as an English article is made to fit the specification the latter is altered. There is no complete means of combating this except the setting up of competitive light and power companies, though the superiority of the English article will still enable it to hold a share of the market, says the London Times Trade Supplement.

In Northern Chile, in the nitrate works and in the mines, there is a considerable field for electric-lighting materials of all sorts and of electric motors. In the nitrate works alone there are about 140 distinct small independent power and lighting installations. As in other lines, Germans have provided cheap and inferior articles, and have in many cases got a contract where price and not quality was the prime factor. This is as might have been expected.

The manufacturer is advised to follow the same system recommended generally for Chile—that is to say, work the market with expert salesmen and demonstrators; use Spanish and metrical system catalogues and establish special agents, or use the established merchant house for the purpose of avoiding the credit danger.

Safe Practice at Blast Furnaces and Its Development-IV.

By Frederick H. Willcox

In its efforts to increase safety in the metallurgical industries, the Bureau of Mines, Washington, D.C., has been studying the causes of accidents at blast furnace plants also methods for their prevention. This article describes the known dangers and makes suggestion of means whereby the risk of accident may be lessened or, better still, wholly avoided.

BOILER-HOUSE FORCE

ALWAYS pay attention to furnace signals for checks, slips, and sboutdowns, and be sure to follow the plant rules for taking boilers off when the furnace is shut down; failure to do so may cause an explosion. When the furnace is hanging and liable to slip, and especially when one or more checks have been blown to slip the furnace, keep away from gas burners, firing and ash-pit doors, and explosion doors; the gas may flare out and burn you when the furnace slips. Do not sit on or near dust boxes, burners, or gas mains; a very small leak will let enough gas escape to "gas" you. Do not stay in any place where you can smell gas. If your work requires you to do so, have a helper with you, and be sure that your foreman knows what you are doing.

Boiler Repair Precautions

Do not go inside a boiler setting to make repairs or clean it until you have stopped with clay all gas leaks about the burners and mains near openings into the setting. If the burner or burner valve leaks and the burner can be pulled back, put a piece of sheet iron between the nose of the burner and the setting. If the burner cannot be pulled back, put a blank flange in the downleg or other feasible place, unless the valve is absolutely tight. Do not enter the setting, boiler, or work on the tubes until the

foreman has either locked or placed danger signs at the gas burners, blow-off valves, and stop valves at the steam leader and feed lines. Wait until the



FIG. 34. WRENCH FALLS AND INJURES HELPER

clinker and dust has been cooled off, and have someone to watch you while inside, and "spell" you off, before entering the combustion chamber. Don't stay inside when turning a hose on the walls to cool them, as the clinker is likely to spall off and expose red-hot brick dust or brick, which may make the water boil and spit and scald you. Before opening manhole covers or tubes the safety valve should be lifted; be sure the steam is entirely exhausted from the boiler.

Unless it is your work and you are familiar with it, do not turn gas into the boilers after a shutdown unless the foreman is present. It may explode and burn you if it is not lighted properly. Similarly, do not turn steam into a cold line or put the boiler on the main steam line unless the foreman, water tender, or head fireman is present. Never open a burner or valve with a danger sign on it. If it appears that someone has forgotten to remove danger signs when through work, report to the foreman. Don't remove the signs yourself unless directed to do so.

Opening Cold Steam Line

To open a cold steam line proceed as follows: First, open the valve drips;

second, open the by-pass or open the stop-valve enough to warm the line slowly; third, do not open the main-line valve until you are certain the line is heated. To turn the boiler into the main steam line:—First, bring the boiler pressure to within 5 pounds of the main-line pressure; second, open the valve next to the boiler slowly; third, open the valve next to the main steam line slowly. To clean boilers:—First, close all stop valves on the steam main (do not depend upon any automatic stop or non-return valve); second, close all valves between the mud drum and the blow-off main; third, if there is but one valve, put a blank flange between the valve and the boiler; fourth, close the stop valves on the feed water next the main line; fifth, close the stop valves on feed line next the boiler; sixth, place danger signs at the valves and lock them; finally, be sure the steam is entirely out of the boiler.

Gauge Glass Removal

In removing and replacing gauge glasses wear heavy goggles. When turning water into a gauge glass place a shield in front of the glass to protect yourself from glass or steam should the glass break, and turn the steam in slowly. Leaks in pipe flanges and gasket or valves should be promptly reported. Never use a hammer, chisel, or wrench on live-steam lines in an attempt to



FIG. 33. WORKMAN PLACES WRENCH CARELESSLY ON LADDER PLATFORM



FIG. 35. CARELESS WORKMAN STANDING INSIDE OF A CABLE BENT AROUND SNATCH BLOCK.

temporarily stop leaks. Watch your steam hose and replace it when it shows weakness. In blowing off boilers open and close the blow-off valve slowly.

In unloading ashes be sure that they are wet down, and in turning water on them do not get close enough to be burned by steam. When unloading coal, wet it down if very dry or dusty. Never use any kind of light other than an elec-



FIG. 36. WORKMAN WEARING GOGGLES WHEN GRINDING TOOL. NOTE GUARDED EMERY WHEEL.

tric light when working about dusty coal, and do not smoke. Neglect of this precaution may cause a violent dust explosion.

Riggers, Millwrights, and Handymen

Don't go on top of the furnace unless you notify the furnace foreman, so that you will not be on top when the furnace is liable to slip. Also notify your foreman so that he can send someone with you. One man should always stay where there is no gas, but in a position to watch the other man while he is inspecting or oiling. If the latter appears to be getting "gassed," the alarm should be given the stock-house or cast-house crew, and every effort made by the watcher to get the exposed man out of the gaseous place, or to keep him from falling while the crews are coming up. Do not go over the receiving hopper unless you notify the skin or bell operator not to operate the bells. Avoid making even routine examinations of hoppers and bells unless the furnace foreman knows that you are doing it and upon what particular top or furnace you are working. Repairs to explosion doors or bleeders or work inside of hoppers should never be undertaken when the wind is on. At shutdown, don't light the gas on top of the furnace until you have received the signal from the blower.

Gas Container Precautions

Before going into gas mains, scrubbers, or any enclosed gas-containing or gas-using place to make repairs or inspections, be sure that every gas connection is closed and the place cleared of gas. Familiarize yourself with the layout of gas valves, water stops, and gas mains, so that you may know where all gas connections are. Always wait until your foreman and the furnace foreman say it is safe to go in. In closing and opening sand, goggles, or slide valves watch for gas. When it is necessary to work in gaseous air, as it often is, to make some other place safe, to shut down or start up a furnace, or other reason, work in "spells," and if you feel sick or dizzy go into fresh air at once. When possible, always wear breathing apparatus or a belt and life line, both in enclosed and unenclosed gaseous places. Avoid smoking in such places.

When it is necessary to examine a chimney valve on a stove, notify the stove tender not to shut the blast off or turn the gas on. Before examining hot-blast valve slots or valves see that the gas is shut off and the chimney valve is open. Do not go inside of a hoist drum to replace or take up the hoisting cable until you have seen for yourself that the steam-stop valve is shut and the pinion blocked in the gear, or, if it is an electric hoist, that the motor switch is locked open and the gears blocked. Avoid trying to adjust the feeding or running on of cables on wrenches or hoist drums while they are in motion. Do not work on cranes, hoists, skip inclines, skip pits, and seals or lorry cars unless you know that the motor switches are locked open. When on crane runways be sure the

wear goggles to protect your eyes from splashes.

Scaffolding Precautions

Before going on scaffolding, inspect it and satisfy yourself that it is safe. Don't lean castings against scaffold uprights or pile material against them. When placing material upon scaffolds let it down carefully, don't throw it down or let it drop quickly, especially if lowering it with a winch or hoist. Place material evenly and look out for overloading. On coming down from scaffolds or platforms don't slide down ropes; use the ladders or steps provided. Never throw tools or other materials down from scaffolds unless the space below is protected with danger signs or a watcher. Do not leave bolts, rivets, tools, etc., on platforms when through work or lay them during the work where they may fall through holes or from the edge of the platform. (See Figs. 33 and 34.) Remember to use care when on ladders.

Do not attempt to tighten or adjust doors, nuts, valves, or packing glands while the blast is on, and avoid rushing repair jobs by loosening too many nuts or keybolts on blast mains, hot-blast valve seats, or heads before the blast is off. Ascertain the correct number to loosen and do not exceed that number.

Hoisting Tackle

Where hoisting tackle is used, the danger of practices such as walking near taut hoist lines, getting foul of guy lines, standing in front of snatch blocks (Fig. 35), etc., may not be apparent to laborers or members of the furnace crew who are helping. You can prevent accident by warning the men of these obscure dangers. Be sure that all hoist lines, cables, chains, tackles, and boatswain's chairs are in good shape before using

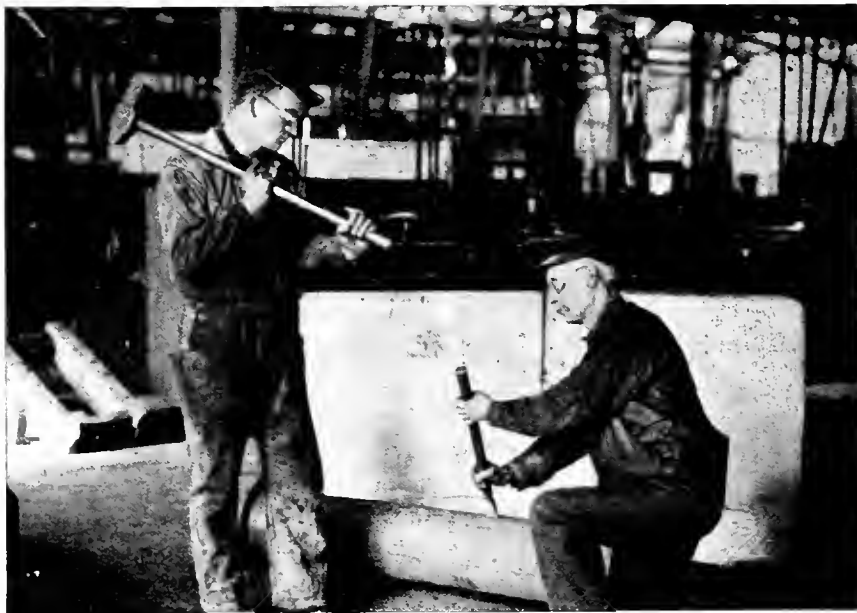

FIG. 37. WORKMEN CUTTING OUT RIVETS AND USING SHIELD. NOTE THAT GOGGLES ARE BEING WORN.

main-line switch is open, or if the crane must be used protect yourself with track torpedoes. When pouring hot babbitt or lead warm the sockets or molds, and

them. Care should be taken in slinging a load to see that the slings are properly arranged and the load balanced and securely fastened to prevent slipping. The

part of the sling from the hook to the load should be long enough so that it makes an angle of more than 45° with the ground. Very short and flat slings are under much greater stress than ones arranged as above. In hooking on the load, watch that your hand does not get caught, and don't grab the cable above the lower sheave block.

Be sure to replace all belt, gear, machine, and engine guards, shields, and railings; they prevent accidents. Do not try to do work on electrical wires or to connect temporary lights. Defective insulation may cause a severe shock or burn, especially if you should be standing on an iron plate. Keep your tools in good shape and return all tools with burrs or mushroomed heads, cracked handles, or other defects for redressing and repairs. Avoid using pipe wrenches, defective wrenches, or a wrench that is too large for the bolt head or nut to be removed. The wrench may either slip or round off the nut. Be especially careful in working on rounded nuts and replace them with new ones at the first chance. Don't cut rivets, bolt heads, or nuts off until you have placed a shield to prevent them from flying, or have a sign or a watcher to warn men of the danger. When chipping or cleaning castings always wear goggles. (See Figs. 36 and 37.)

Regular inspection of hoists and skips, brasses, bells, sheaves, hoppers, and valves, may prevent sudden shut-downs and extra hazardous work. Members of rigging and millwright gangs, being in every part of the plant in their regular work, should know more about many obscure and not readily apparent dangers than most of the furnace force. It should be a part of their duty to report any dangerous practice or condition. There are many trivial sources of accidents, so many that no one man or committee can see them all, or, in some cases, even know that they exist until injury results.

NOTES ON HAND GRINDING

THE most common type of wheel is the ordinary straight wheel. It resembles a disc in shape, the sides are parallel and the hole rarely exceeds 2¼ ins. to 2½ ins. diameter. Another type of wheel is that known as the tapered, bevelled, or safety shape wheel. This type has the taper or bevel on both sides, or only one side. The taper is expressed in inches per foot, starts from the face and extends to within a short distance of the hole. Cylinder wheels may be considered as ordinary, very wide, straight wheels with very large holes, so that the thickness of the wall is comparatively small in relation to the diameter of the wheel.

In accordance with the rulings adopted July 1, 1915, by the grinding wheel manufacturers of the United States and Canada, a cylinder wheel is 8 ins. or more outside diameter; 4 ins. or more in height, with a hole not less than 6 ins. diameter, rim thickness not exceeding 4 ins., and without inside projec-

tions. Another type of wheel is that known as the cup wheel, and may be classed as a cylinder wheel with an inside projection. This is referred to as a back. Another way of looking at it is to conceive of a cup wheel as a combination of a cylinder and a straight wheel of the same diameter.

Straight, tapered and cup wheels are mounted between flanges, while cylinder wheels are always used in a chuck. Straight wheels, tapered wheels and cup wheels should always be surrounded by a well-designed, substantial protection hood, but in the case of cylinder wheels, the retaining chuck offers sufficient protection.

Grinding is done upon the face of straight and tapered wheels, and upon the rim of cup and cylinder wheels. As straight and tapered wheels wear down unless the number of revolutions per minute is correspondingly increased, there will be a decrease in the peripheral cutting speed. With cylinder and cup wheels, however, the cutting speed remains constant throughout the life of the wheel as long as the revolutions per minute are not changed. Cup and cylinder wheels are best adapted for work which requires a straight, flat surface. Unless the cutting particles in a cup or cylinder wheel are very coarse, it will be found that the straight or tapered wheel will cut more rapidly, due to the pressure being concentrated over a small area of "narrow contact" as it is sometimes referred to.

Hand-Grinding Machines

Hand-grinding machines can be successfully driven by means of belts, direct-connected motors and silent chains, the first two being by far the most common. A combination of motor and belt-drive is proving satisfactory in a number of instances and is referred to as the group-drive method. Four, five or possibly six machines may be driven by means of belts from a piece of shafting which, in turn, is driven by means of a belt from a centrally located motor.

Which method of driving is the most economical depends entirely upon local conditions. Where it is necessary to keep machines in almost continuous operation, the group-method of driving from a central motor is found very satisfactory. However, where the work is liable to fluctuate, so that there are considerable periods during the working day when a machine is not in operation, individual direct motor drives or belt drives from individual motors, prove to be most satisfactory. When a machine must be located in a building with a very high ceiling and away from columns or girders, the direct motor drive is always specified. The manufacturers of the silent chain claim high operating efficiency, due to the impossibility of slippage between the wheel and the source of power. A number of plants, however, have not found chain drives satisfactory, due to the fact that continual attention is needed to keep the chain in repair, and wear due to dust and grit is very rapid.

Speed of Grinding Wheel

A speed of 5,000 peripheral feet per minute is recommended as the standard operating speed for vitrified and silicate straight wheels, tapered wheels, and shapes other than those known as cup and cylinder wheels which are used on bench, floor, swing-frame and other machines for rough grinding. Speeds exceeding 5,000 feet may be used upon recommendation of the wheel manufacturer, but in no case shall a speed of 6,500 peripheral feet per minute be exceeded.

A speed of 4,500 peripheral feet per minute is recommended as the standard operating speed for vitrified and silicate wheels of the cup and cylinder shape used on bench, floor, swing-frame and other machines for rough-grinding. Speeds exceeding 4,500 peripheral feet per minute may be used upon recommendation of the wheel manufacturer, but in no case shall 5,500 feet per minute be exceeded.

For elastic, vulcanite and wheels of other organic bonds, the recommendations of individual wheel manufacturers should be followed.—*Grits and Grinds.*

PAINT COATINGS THICKNESS

THE average thickness of a coating of paint for iron and steel may be one two-hundredth of an inch, states an authority on the subject. In many parts, however, the coating may easily reach a thickness of one six-hundredth of an inch. If, therefore, a paint contains particles whose smallest dimension is one four-hundredth of an inch, it is obvious that the particle will stand out in a paint coating where the thickness of the paint coating is only one six-hundredth of an inch. Many particles of pigment classed as coarse or sandy lead are considerably larger in size than the size indicated by one four-hundredth of an inch diameter, and these will project still farther through the paint film. Such coarse particles become, therefore, the weak point in the film, and corrosion may start around such particles. The paint film itself is weak at such points, as the coarse particles may not be completely encased in the oil of the film. For these reasons, concludes the authority, the superiority of a highly-oxidized red lead is really due to its fineness. It is a better pigment. Its superiority, however, lies not only in the more continuous paint film it produces, but in its producing a better working paint—a paint that flows out well but will not run, sag, or weep.

GENERALLY speaking, each metal and alloy has a particular temperature at which it possesses maximum fluidity, this temperature usually being only slightly higher than the fusing point. Metal should always be poured as soon as ready, as it deteriorates if held too long in a molten condition.

PROGRESS IN NEW EQUIPMENT

A Record of New and Improved Machinery and Accessories for the Machine, Pattern, Boiler and Blacksmith Shops, Planing Mill, Foundry and Power Plant

DIE MUZZLING MACHINE

IN the manufacture of threading dies of any size, one of the most difficult operations is that which is known as muzzling. This operation consists of beveling of the first two or three threads of the die in such a way as to secure a clearance so that as the die is made to work it will cut readily and without dragging. This clearance is quite similar to the clearance which is introduced on the end of a machine reamer, though the clearance is internal in the die which is contrary to that of the reamer. This operation is usually performed by hand with a small file and requires considerable skill and training on the part of the operator. The machine illustrated in the accompanying photographs, has been designed to eliminate the hand work in this particular operation, a super-helical cutter making it possible to machine the delicate threaded cutting edges without raising a burr. The cutter is made cone-shaped, the angle of the side of the cone depending on the number of threads which it is desirable to relieve or back-off; as, for example, a cone representing an angle of thirty degrees on the side will machine a clearance of about two and one-half to three threads

whereas a cone of an angle of forty-five degrees on the side will form a clearance of one and one-half threads only.

The machine in the main consists of a hollow vertical spindle mounted in a frame and running on ball bearings. The chuck for holding the cutter is a split collet so that the cutters will run true under all conditions. On the spindle is mounted a friction member. This friction member is driven by means of spherical faced disc which is mounted on the armature shaft of the motor, the motor being pivoted in the frame of the machine in such a way that by tilting it, the speed of the cutting tool can be varied in order that with dies where a portion of the large diameter of the cutter is used, the speed can be reduced or increased to suit. The spindle can be locked by means of a bolt at the side or front of the machine to enable the operator to fasten the cutter securely in the chuck or collet-sleeve, a draw-bar having a knob or hand wheel at the top of the machine operating the chuck mechanism, similarly to the draw-bar used in ordinary bench lathes.

The table is of rectangular shape and provided with a cross-wise slot into

which the fixture is secured. This fixture is primarily two slides so as to permit adjustment in all directions, making it possible not only to operate the large as well as small diameters, but also to vary the amount of clearance on the cutting edges of the die. On the upper slide of this fixture is located a pivoted finger mechanism adjustable on this slide. This index finger locates the cutting edge of the die that is being operated on in the right relation to the cutter, and is pressed down by a spring into the openings of the die, resting with a slight tension on top, and so constructed that the die can be rotated under the finger from one cutting edge to the other. The portion

of this finger which engages the die can be removed, and as many shapes and forms of fingers as may be necessary can be made and applied by inserting in a holder.

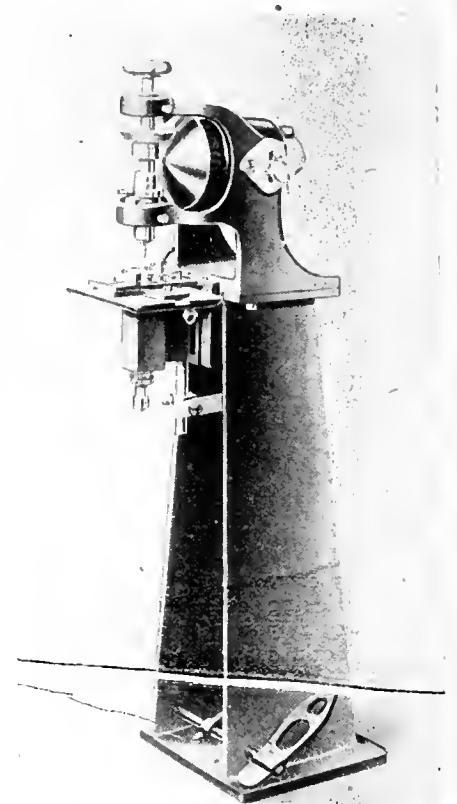

DIE MUZZLING MACHINE.

The table is raised and lowered by means of adjustable foot treadle mechanism located at the lower right hand side of the pedestal. If necessary, a safety spring device can be introduced in this connection between the foot treadle and the table so that regardless of the pressure applied by the operator on the foot treadle, the pressure exerted on the table spindle will be uniform.

Any make of motor not exceeding 6 in. in diameter can be applied to this machine, 1-16 h.p. 1700 R.P.M. being ample for the operation. A switch is conveniently located for starting and stopping the machine. Cord with attachment plug so that the machine can be run from the ordinary lamp socket is also furnished. The Anderson Die Machine Co., Bridgeport, Conn., are the makers of this machine.

LARGE HEAVY DUTY LATHES

THE heavy and constant demand for lathes during the last two years which was largely concentrated on medium sizes when munitions orders were first

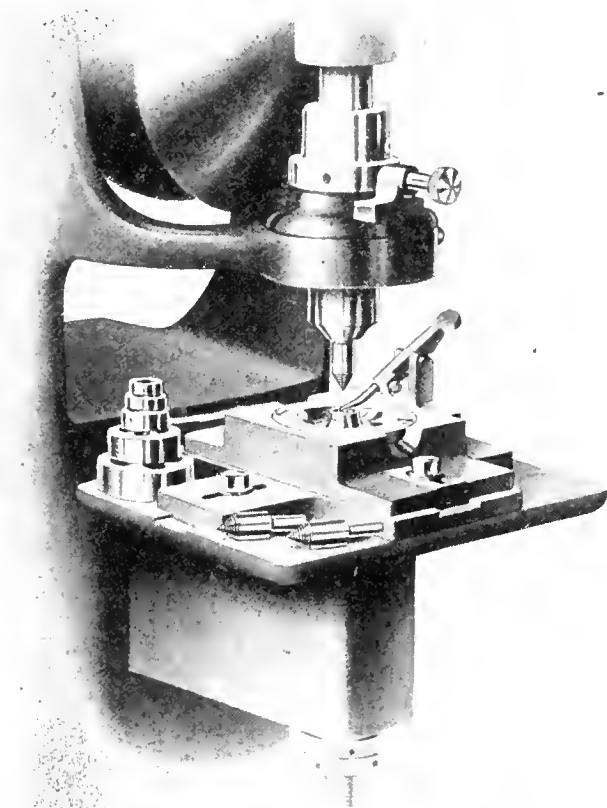

INDEX FINGER, WORK TABLE AND CUTTERS OF DIE MUZZLING MACHINE.

undertaken, has of late been tending toward larger machines in line with more recent munitions contracts, and requirements in this respect have been met by a line of heavy duty lathes with

and cone pulley, the conventional spring plunger operated by hand having been discarded for reasons of safety and efficiency.

Double back geared lathes with selec-

cocking of the carriage. The front vee is lubricated by means of atmospherically sealed oil pockets inside the carriage, shear wipers being also fitted to both front and rear vees.

Four stud tool rest is ordinarily furnished, and the compound rest has a special square base avoiding overhang of the top slide. Tapered gibs are fitted to both upper and lower slides, and the compound rest is graduated in such a manner that the graduations may be read from above.

The double wall apron is tongued to the carriage and carries all steel gears, while the rack and certain parts are heat treated; bronze bushings are employed where steel would run on steel otherwise. Two positive clutches are employed for carriage feeds, preventing loss of capacity through slippage of frictions, while a safety shearing pin carried by two discs on the front of the apron prevents dangerous overload on the mechanism. Forty-eight changes of feeds or threads are provided, all gears from spindle to apron being steel, the feed mechanism being simple and entirely accessible.

The tailstock is secured in position by four large hold-down bolts with heavy clamps, which are located toward headstock end of tailstock. A retaining pawl with rack, and gear traverse are arranged therewith, while the locking clamp or spindle does not destroy alignment.

Motor drive by either d.c. or a.c. current is provided for, the selective speed type of headstock being used when constant speed motors are employed. These lathes are built in any length of bed from 12 ft. up, and included in the regular equipment are compound rest, steady rest, large face plate (also small face plate for double back geared lathes), double friction countershaft for belt-driven lathe, centres and wrenches. The 36 in. double geared machine weighs 18,000 lbs., and with triple gear 24,000 lbs., the full line of this maker's product being marketed in Canada by the Rudel-Belnap Machinery Co.

First-class tool steel is now being made at the Lisvensky works in the Urals, Russia, and preparations are being made to increase the output after the war. This commodity was formerly imported in large quantities.

—*—
Took Her Cue from Pa.—A little girl, being invited to a children's party, was cautioned by her mother how to behave, and that when the cake came round the first time she should say, "Yes, please," and take a piece; also the second time to do the same, but at the third time of asking she was to refuse any more cake and say, "No, thank you." The next morning the mother asked her little girl how she got on at the party. "Well, mother, I did as you told me; but they brought the cake round a fourth time, and you didn't tell me what to say. So I looked at the lady and said, 'Take the damned thing away' like pa says."

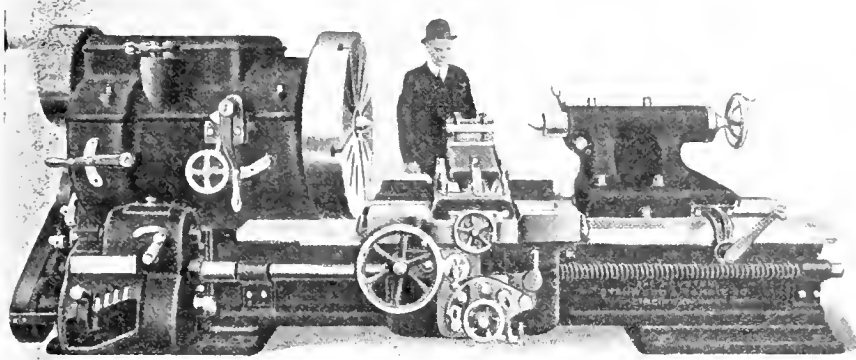

TRIPLE-GEARED HEAVY DUTY LATHE WITH SINGLE PULLEY SELECTIVE SPEED HEADSTOCK.

a nominal swing of from 30 in. to 42 in., the product of Houston Stanwood & Gamble Co., Cincinnati.

Four distinct machines constitute this series, viz., 30 in. and 36 in. double back-geared, swinging 34½ in. and 40½ in. respectively over vees, and 36 in. and 42 in. triple geared, swinging 41 in. and 46½ in. respectively, over vees.

The general lines of the headstock are the same in the several sizes, the front and rear walls being carried up to the centre line of the leaving no exposed gears on shafts even in the cone-driven type. A feature of the design is the arranging of all the principal driving elements and operating levers below the centre line in identical manner so that a cone headstock can be changed to a selective speed headstock at any time with discard of the cone only.

All speed gear changes are obtained through the levers and hand wheel on front of the headstock the handwheel appearing on the triple geared lathes only. The horizontal lever operates the back gears, and the vertical lever operates a jaw clutch between the face gear

tive speed headstock have twelve speed changes, and triple geared lathes of the same style have fifteen, which with a two speed countershaft provides 24 and 30 speeds respectively. Both spindle and back shafts are of high carbon steel, accurately ground, with large hole through spindle, and all bearings are bronze bushed. Special attention has been given to lubrication. All gears in motor-driven and selective speed lathes running in oil with a splash system. Wrought or cast steel is used for all gears except a few large gears subject to low pressures, these being of steel mixture, while all proportions are designed for loads considerably in excess of normal.

The design of the bed adopted is in line with most advanced practice, the front vee having a large bearing surface on top, with the front and rear bearing surfaces so disposed as to constitute a long narrow guide for the carriage. Gibs at the front of and underneath the front vee, and also underneath the rear vee are adjustable and prevent lifting or

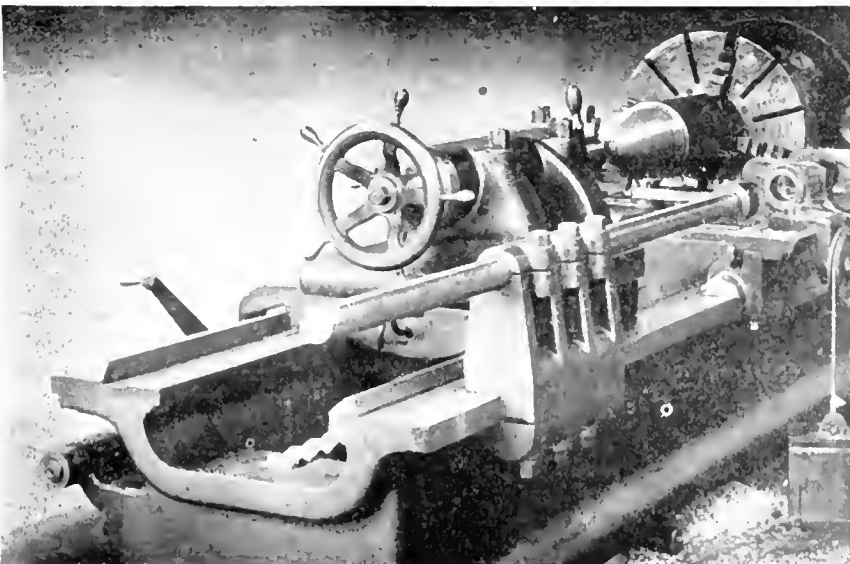

PROFILE ATTACHMENT FITTED TO HEAVY DUTY LATHE

The MacLean Publishing Company

LIMITED

(ESTABLISHED 1888)

JOHN RAYNE MACLEAN - - - - - President
H. T. HUNTER - - - - - Vice-President
H. V. TYRRELL - - - - - General Manager

PUBLISHERS OF

CANADIAN MACHINERY AND MANUFACTURING NEWS

A weekly newspaper devoted to the machinery and manufacturing interests.

PETER BAIN, M.E., Editor. B. G. NEWTON, Manager.

Associate Editors.

A. G. WEBSTER, J. M. WILSON, J. H. RODGERS.

Office of Publication, 143-153 University Avenue, Toronto, Ont.

Vol. XVII. FEBRUARY 22, 1917 No. 8.

BUSINESS OUTLOOK CONTINUES FAVORABLE

ALTHOUGH the immediate outlook continues somewhat unsettled, the opinion is becoming more generally held that even should the United States enter the war arena on the side of the Allies, the industrial situation in Canada will be but slightly affected, if at all. At least, while the war lasts, and regardless of whether only preparedness or entry into the war be the ultimate outcome across the line, capacity business is assured for Canadian steel producers. For this reason the latter are likely to continue to enjoy for a good many months to come the activity and in large measure the prosperity which they experienced during 1916. Extreme and violent declines in stocks are thus unlikely, although fluctuations, with a steady downward tendency, will occur more so than in normal times on account of war-engendered business sensitiveness.

Steel Production Earnings

It is extremely doubtful if steel production earnings and therefore profits for the first quarter of this new year will be as great as anticipated some few months ago, owing to the curtailment of output. In this regard the situation is not particularly bright for immediate improvement, owing to transportation difficulties, the recent severe weather having still further restricted the movement of cars on the railways, and in consequence, offset the advantages expected to be derived from the transfer of passenger train motive power and crews to that of freight haulage.

Conservative Distribution of Profits

The more or less conservative policy being pursued by our various steel companies relative to dividend distributions is such as to commend itself not only to our citizens generally, but to the investing public as well. While big profits were undoubtedly earned during the first eighteen months or so of the war, it is only reasonable to expect that due to keener prices now in evidence the various executives concerned feel it incumbent upon them to get rid of the many heavy indebtednesses incurred, and that were as a matter of course incidental to the establishment and development of an industry so gigantic as that of steel manufacture in a comparatively new country. The opportunity to do so is for the first time available, and there is

every indication that it will be fully taken advantage of. In the ensuing twelve months, or for the remaining period of the war, profits arising from steel contracts for munitions are likely to be a shade, at least, under those realizable from normal peace-time business, a circumstance which serves to indicate that further opportunity to accumulate cash reserves on a big scale will not be available. By adopting the policy outlined, not only will the old-time millstones of heavy indebtedness be cut loose, but bank balances of the most substantial proportions and the physical condition of plants and equipments be enhanced in value as operating assets, necessities, individual and in combination to take full advantage of the many peace-time business offerings which are certain to develop.

Railroad Transportation Causing Anxiety

Both Canada and the United States for many months now have been experiencing big business in a manufacturing sense, same having, from foundation to superstructure, steel as the main constituent. Troubles inherent to it have been successfully surmounted. Not so, however, as regards that outside its pale, yet accessory—the matter of transportation of material. In a word, our manufacturers have taken the overload of big business comfortably, while our railroads, so to speak, have gone to pieces under it. Preceding and immediately following the outbreak of the war, our railroads more than any other section of our commercial and industrial enterprise set the pace for retrenchment in expenditures, and as each succeeding month unfolded, the disposition to maintain a like attitude appears to have been still further encouraged. Some three years have elapsed, as a consequence it is only reasonable to assume that rolling stock in any quantity is far from available to meet the abnormal traffic now in evidence, and that additions to it, aside altogether from the upkeep and overhauling of that existent, are financially burdensome with material and labor costs at their present figures.

Railroad Buying Long Overdue

That our railroads will have to come into the market sooner or later with very substantial orders for equipment of every kind is of course understood, because otherwise that species of transportation will go from bad to worse, and meantime it would almost appear that we are now making contact with the latter. There is a problem here: Can our railroads pay the price for material on existing freight rates? We think not, even although they have been to a very great extent responsible for the present highly unsatisfactory state of affairs. We are of opinion that steel for much new rolling stock, also steel rails in quantity will yet have to be purchased at prices little, if any, below those now ruling.

* Steel for Shipbuilding

High steel prices are sure to prevail for the duration of the war, and on some products, particularly plates, for a considerable time afterwards. The demand for ship sections and plates is far in excess of present production, the mills having their output in various forms sold for the whole of this year. Prices, consequently, are very high, and the crest of the upward movement is not in sight. The ships lost during the war will have to be replaced; the outlook in the shipbuilding industry is thus exceptionally bright. The large number of ships now being built in the United States and Canada is largely responsible for the tight situation in the plates and shapes market. Canadian shipbuilders are participating to the fullest extent in the construction of new tonnage, the yards on both coasts and on our inland lakes being full up with orders. Notwithstanding the high costs of plates this activity is sure to continue until the shortage of tonnage has been well met. Getting plates, even at any price, is quite a problem.

INDUSTRIAL NOTABILITIES

PERCY FORD-SMITH, president and general manager, Ford-Smith Machine Co., Hamilton, Ont., is of English birth and parentage, having been born at Wolverhampton, Aug. 10, 1881, his ancestors on both sides of the family having been English as far back as records are available. After graduating from high school he attended the Royal Technical Institute, Manchester, and served an apprenticeship of seven years with Smith and Coventry, Ltd., Manchester, one of the principal machine-tool firms in Great Britain. Four years of this period were spent in the shops, and three years in the drafting-room, the experience gained thereby being supplemented by three years in the United States, during which time Mr. Ford-Smith was employed in several machine-tool plants in various capacities.



PERCY FORD SMITH.

Mr. Ford-Smith returned to England at the expiry of this period, under a four-year contract with a prominent machine-tool concern, during which time he modernized their plant in line with the best practice then extant. He then came to Canada and became chief draftsman with the London Machine Tool Co., Hamilton, leaving them to organize the Ford-Smith Machine Co., Ltd.

The building of grinding machines and special machinery occupied his attention until the outbreak of hostilities, since when special applications of his machines to munitions production have been a feature of the business.

Since the beginning of the war he has devoted much of his time to recruiting, and holds a lieutenancy in the Canadian Engineers.

Mr. Ford-Smith is Independent in politics, and in religion is Church of England. He married Olive Spengler, daughter of Prof. A. Spengler, late of Western Reserve University, Cleveland, O., and has a family of three children.

BOILER TUBES.

Size.	Seamless	Lap-welded
1 in.	\$22 00	
1 1/4 in.	25 00	
1 1/2 in.	29 00	24 00
1 3/4 in.	30 00	22 50
2 in.	33 00	20 00
2 1/2 in.	35 50	29 50
3 in.	46 00	34 50
3 1/4 in.		41 00
3 1/2 in.	53 00	41 00
4 in.	65 00	55 00

Prices per 100 feet, Montreal and Toronto.

OILS AND COMPOUNDS.

Castor oil, per lb.	25
Royalite, per gal., bulk.	12
Machine oil, per gal.	25 1/2
Black oil, per gal.	12 1/2
Cylinder oil, Capital	45 1/2
Cylinder oil, Acme	36 1/2
Standard cutting compound, per lb.	0.6
Lard oil, per gal.	1 45
Union thread cutting oil	
antiseptic	68
Acme cutting oil, antiseptic	37 1/2
Imperial quenching oil	39 1/2
Petroleum fuel oil	12

BELTING—NO. 1 OAK TANNED.

Extra heavy, single and double	30-5%
Standard	40%
Cut leather lacing, No. 1.	\$1 55
Leather in sides	1 35

TAPES.

Chesterman Metallic, 50 ft.	\$2 00
Luffkin Metallic, 603, 50 ft.	2 00
Admiral Steel Tape, 50 ft.	2 75
Admiral Steel Tape, 100 ft.	4 45
Major Jun. Steel Tape, 50 ft.	3 50
Rival Steel Tape, 50 ft.	2 75
Rival Steel Tape, 100 ft.	4 45
Reliable Jun. Steel Tape, 50 ft.	3 50

WASTE.

White	Cents per lb.
XXX Extra	20
Peerless	20
Grand	19
Superior	19
X L C R	18
Atlas	18
X Empire	17
Ideal	17
X press	16

COLORED.

Lion	14 1/2
Standard	13
No. 1	13
Popular	11 1/4
Koen	10 1/2

WOOL PACKING.

Arrow	25
Axle	20
Anvil	15
Anchor	11

WASHED WIPERS.

Select White	12
Mixed colored	10
Dark colored	09

This list subject to trade discount for quantity.

RUBBER BELTING.

Standard	50%
Best grades	30%

ANODES.

Nickel	.50 to .54
Cobalt	1.75 to 2.00
Copper	.44 to .46
Tin	.49 to .53
Zinc	.23 to .25

Prices Per Lb.

COPPER SHEETS.

	Montreal	Toronto
Bars, 1/2 to 2 in.	\$46 00	\$46 00
Plain sheets, 14 oz., 14x28 in., 14x60 in.	45 00	45 00
Copper sheet, tinned, 14x60, 14 oz.	54 00	54 00
Copper sheet, planished, 14x60 base.	57 00	57 00
Braziers' in sheets, 6x4 base	46 50	46 50

BRASS.

Brass rods, base 1/2 in. to 1 in. rd.	0 55
Brass sheets, 8 in. wide, 20 oz.	0 10
Brass tubing, seamless.	0 55
Copper tubing, seamless.	0 55

PLATING SUPPLIES.

Polishing wheels, felt.	2 10
Polishing wheels, bull-neck	1 35
Emery in kegs, American	06
Paints, ground	04
Emery glue	15 to 20
Tripoli composition	04 to 06
Crocus composition	07 to 08
Emery composition	08 to 09
Rouge, silver	35 to 50
Rouge, powder	30 to 35

Prices Per Lb.

LEAD SHEETS.

	Montreal	Toronto
Sheets, 3 lbs. sq. ft.	\$12 00	\$14 00

Sheets, 3 1/2 lbs. sq. ft.	11 76	14 00
Sheets, 4 to 6 lbs. sq. ft.	11 50	18 50
Cut sheets, 1/4¢ per lb. extra		
Cut sheets to size, 1¢ per lb. extra.		

PLATING CHEMICALS

Acid, boracic	8 15
Acid, hydrochloric	.05
Acid, hydrofluoric	.14 1/2
Acid, nitric	.10
Acid, sulphuric	.05
Ammonia, aqua	.08
Ammonium carbonate	.15
Ammonium chloride	.11
Ammonium hydrosulphuret	.40
Ammonium sulphate	.07
Arsenic, white	.12
Copper, carbonate, anhy.	.25
Copper, sulphate	.17
Cobalt sulphate	.70
Iron perchloride	.20
Lead acetate	.16
Nickel ammonium sulphate	.12
Nickel carbonate	.35
Nickel sulphate	.15
Potassium carbonate	.75
Potassium sulphide (substituted)	.20
Silver chloride (per oz.)	.65
Silver nitrate (per oz.)	.65
Sodium bisulphite	.10
Sodium carbonate crystals	.05
Sodium cyanide, 127-130%	.41
Sodium hydrate	.04
Sodium hyposulphite, per 100 lbs.	5.00
Sodium phosphate	.14
Tin chloride	.60
Zinc chloride	.60
Zinc sulphate	.09

Prices Per Lb. Unless Otherwise Stated.

The General Market Condition and Tendency

THE congestion of freight at railroad terminals continues to cause great inconvenience to manufacturers and merchants in the matters of shortage of fuel and delay in receipts of their raw and finished materials. The railways, owing to shortage of labor, cars and motive power, seem unable to cope with the situation, which is serious, notwithstanding the extraordinary efforts now being made to relieve the congestion. The severe weather has, of course, made conditions more difficult to deal with, and for the same reason the situation is more acute. Manufacturing operations are being curtailed, which is unfortunate, particularly at a time when trade is unusually active. Although there has been no important change in the international situation, developments are being watched with considerable interest in business circles. Conditions as they effect the steel mills and foundries in this district show no improvement and production is being curtailed owing to the continued shortage of coke and pig-iron. These materials are becoming more difficult to obtain as conditions in the United States are, if anything, worse. The natural result will be higher prices on steel products. Plates have already advanced, while higher prices on black sheets, among other products, may be looked for at an early date. There are no quotations obtainable on domestic foundry pig-iron, as this material is still off the market. Prices on copper and other ingot metals, with the single exception of tin, are holding firm. Lead has advanced, due to a scarcity of spot supplies. The international situation is a controlling factor in the metal markets and the possibility of increased demand is tending to hold prices firm. The machine tool trade continues quiet, awaiting developments. Prices on machine tools have an upward trend and deliveries are, if anything, a little better. Prices of copper and brass scrap have advanced, and the market is very firm for old materials of every kind.

with the scarcity of other raw material, has forced curtailment upon the general output, with the partial shut down of several furnaces and mills. Unsettled conditions across the line tend toward still further difficulties, with little prospect of early relief.

Pig Iron

The abnormal demand for pig iron, more especially Bessemer and basic, together with the curtailment of production caused by the lack of raw materials, is creating a serious situation, and unless some relief is given to the freight congestion, the stoppage of mills may greatly affect early future conditions. Latest reports from the Pittsburg district indicate a very strong market on advancing prices; Bessemer and basic being \$1 a ton higher than last week.

Steel

Throughout the entire steel trade the situation is featured by the pronounced shortage of fuel; this factor having a serious effect upon production, as many mills have been forced to curtail their output owing to lack of raw material. The tie-up of export shipping has caused large quantities of material to accumulate on the seaboard, and cargoes are numerous on certain goods going East. The shortage of cars is quite serious, but the lack of men and motive power is the chief reason for present conditions; prospects for early relief are not bright, and the outlook seems to indicate still more serious developments. With conditions tending to increased difficulties, both as regards production and transportation, early advances are anticipated. The situation in Bessemer billets

Montreal, Que., Feb. 19, 1917.—The outstanding feature of the industrial situation is the freight congestion, which is creating serious conditions in production and transportation circles. The non-delivery of coke and coal, together

and sheet bars is more acute, Bessemer pig having advanced \$1 per ton over that quoted at Pittsburg last week. No relief is evident in ferro-alloys, as the supply is still scarce; quotations are withdrawn and higher prices will likely prevail. The production of plates is still below the demands, and mills are unable to keep pace with trade requirements, which are daily increasing; car inquiries are lighter, but ship plates are in exceptional demand. With the sheet mills filled to capacity and some producers withdrawing quotations, higher prices seem imminent. Quotations on manufactured steel are advancing, the discount on pipe having been reduced two points during the week. Increased activities are developing in wire and wire products, and more pressure is being placed on producers for future requirements.

High Speed Steel

Political developments in the States may create an increased demand for high speed steel, and dealers here anticipate a stronger market should war be declared. Prices at present are firm at from \$2.50 to \$2.75 per lb.

Metals

The difficulty of obtaining delivery on material has had a strengthening effect generally, but with the obvious discounting of the submarine menace, a more even tone is apparent. Copper is higher and active. Tin is lower, following safe arrivals of shipments. Spelter is quiet, but unchanged. Lead is strong, due to scarcity of spot supply. Antimony is weaker, but developing firmness.

Copper.—Prevailing conditions are still retaining copper in a strong position, but the near future may see changes, inasmuch as export metal is accumulating at various points owing to tie up of ocean bottoms. Should submarine activities prevent the export of copper, the available supply may result in a weaker market, but little is expected to be offered for sale owing to its being under contract for the British Government. Advances on the New York market range from 1c on lake to 2½c on castings. Owing to the non-delivery of metal and the freight congestion, local dealers are asking 40c for lake and electro, and 39c for castings, this representing an advance on the week of 3½c per lb.

Tin.—The submarine scare having decreased somewhat, the easier tone is reflected in the gradual return to conditions of a few weeks ago, and lower quotations are more general, but no sharp decline is expected, as the marine risks are not yet entirely removed. Both London and New York markets are easier, and quotations are lower, the New York decline being 4c, or a current quotation of 50c per lb. The local market has become more accessible on a decline of 5c, the nominal quotation being 51c per lb.

Spelter.—Activity in spelter is confined to the selling of small lots, buyers not showing any great interest in large orders. Like other metals, spelter is affected by existing conditions. The

market here remains unchanged, with prices firm at 15c per lb.

Lead.—The apparent scarcity of spot metal continues to force prices upwards. The advance has resulted from the urgent requirements of certain consumers and their willingness to pay exceptional prices for supplies. The freight situation is chiefly responsible for the advance, and early relief seems unlikely. New York independents are asking as high as 10¼c per lb. Local dealers are dubious about prices, but quote the nominal figure of 12½c.

Antimony.—Activity is not pronounced, demand being light. The supply is not very great, however, and any heavy inquiry would result in higher prices. Quotations on the New York market are 5c lower than last week, the price quoted being 30c per lb.

The local situation has become easier, and dealers have declined to 30c, this being 7c lower than last week.

Aluminum.—The market is unchanged and quotations remain firm at 70c per lb.

Machine Tools and Supplies

The market for machine tools has shown some improvement during the past few weeks, more especially for additions to 4.5-inch shell equipment. The changes called for by the specifications entail increased work on the interior, and inquiries for boring machines have increased. Partly used machinery from the States, which a few weeks ago appeared to be featuring the Canadian situation, has not been so freely offered, owing to possible developments. Higher prices would naturally follow a war declaration, with increased difficulty in obtaining delivery from American machine tool makers.

Scrap.—The market is in an unsettled condition, but comparatively firm. Copper, lead and zinc were higher earlier in the week, but the general market continues steady, with no important features outside of a stronger undertone, which may be reflected in advances upon early developments.

Toronto, Ont. Feb. 20.—The freight situation continues to cause considerable anxiety to manufacturers in spite of the extraordinary efforts that have been and are being made to relieve the congestion. Not only is the shortage of fuel causing much inconvenience, but shipments of raw materials and partially manufactured goods are being held up and so restricting manufacturing operations.

Steel

There is no evidence as yet of any improvement in the steel situation notwithstanding the strenuous efforts that are being made to break the blockade at Buffalo. There has been a heavier movement of coal during the week, but the shortage of fuel and pig iron still continues to be the dominant factor in the iron and steel trades. Mills in Canada depending upon the States for supplies of coke, and to some extent for pig iron, are confronted with conditions

which are steadily getting worse owing to the embargoes on the railways in the U.S. restricting the movement of cars. No immediate relief is in sight, although with milder weather becoming imminent, the railways will have a better chance to cope with the situation. The mills already well sold up, are getting further behind on deliveries due to curtailed production and increase in demand. The steel market is thus very strong and higher prices on steel products are inevitable. Plates have already made a further advance of 25 cents, and are now quoted as follows: ¼ in. and larger \$6; heads \$6.35; tank plates \$5.85 per 100 lbs. The large increase in ship construction has intensified the demand for plates, but owing to the sold-up condition of the mills, deliveries are very slow while plates for early deliveries continue to bring extremely high prices. Makers of boiler tubes, have practically their entire output sold up over the remainder of the year and prices are very firm with an upward tendency. Prices of iron and steel bars continue very firm, and a further advance is likely.

The demand for high-speed tool steel continues heavy, and it is still a difficult matter to obtain supplies of this material from England or the States. There is very little steel coming from Sheffield owing to the heavy requirements of the British Government. Some tool steel can be obtained from U.S. makers, but deliveries are slow and quantities much below requirements. Domestic tool steels are finding a ready sale at firm prices. There is thus very little change in the high speed steel situation and prices are practically the same, ranging from \$2.50 to \$3 per pound according to quality. Carbon steels are advancing in price.

Production of sheets continues to decline owing to short deliveries of coal and sheet bars. The situation is serious as some mills will have to close down unless supplies of coal come forward more freely. The leading interest in the States announces that it has withdrawn from the market on all grades of sheets for shipment up to July 1, its product being sold up; as a result prices are very firm and will go higher. Galvanized sheets will doubtless be affected for the above reason and also on account of the scarcity and high cost of acids.

Producers of iron and steel in the States are suffering severely from the reduction in freight movements. The congestion of freight at the seaboard has resulted in embargoes on practically all the railways affecting the entire country particularly in the East. The production of both iron and steel is greatly restricted and the situation is getting daily more acute. Prices are tending upwards in all directions, and the prevailing high cost of pig iron will affect prices of finished materials.

Pig Iron

There is no improvement in the pig iron situation, and the market is upset. The coke shortage in the U.S., due to

lack of cars and motive power has resulted in many furnaces being banked. There is therefore a shortage of pig iron which is seriously affecting the steel mills. Foundries are also severely handicapped and in some cases have practically closed down. Canadian foundry pig iron continues off the market owing to the shortage of coke and no prices are being quoted.

Scrap

Prices on all old materials are very firm. Quotations on copper and brass scrap are about 2 cents higher in sympathy with the increased cost of ingot metals. All steel scraps are very firm, but unchanged with the exception of low phosphorous steel which has advanced 4 cents, although the price is really nominal as this material is practically off the market meantime. Scrap leads have advanced, and zinc is also a shade higher. Stocks of machinery scrap iron are light owing to a heavy demand, due to the scarcity of pig iron.

Machine Tools

The machine tool market is quiet and may be said to be awaiting developments. The international situation is a factor of considerable importance, while there is also the placing of further shell contracts to be considered. Business now consists principally of single tools for munitions plants as replacements, or to increase production. There is no indication of a decline in prices, the tendency being all the other way. United States builders of special railroad shop tools have raised their prices 10 per cent, which is the first advance for some time.

Supplies

The demand for machine shop supplies continues active with a general tendency towards higher prices. Lead sheets have advanced 1½¢ per pound, and lead wool 1¢, the latter being quoted at 14¢ per pound. Gasoline and coal oil are in good demand with prices very firm. Higher prices on gasoline are looked for in the near future. Linseed oil is very high in price, being now quoted at \$1.40 for raw, and \$1.43 for boiled oil. Putty has advanced 20¢ per 100 pounds.

Metals

The international situation continues to affect the metal markets and is tending to make prices firmer in anticipation of increased demand. The submarine situation is also affecting the markets, but not to any material extent as the opinion is generally held that the submarine operations will not interfere with shipments of metals to an extent sufficient to cause any serious delay or loss of cargoes.

Copper.—Quotations on copper continue nominal, there being very little spot metal for sale to form a basis for prices. Producers are falling behind in shipments while some consumers are suffering from a shortage of copper and are compelled to pay very high prices. Copper is unchanged locally at 38 cents per pound.

Tin.—The market is easier due to arrivals in New York of large amounts of tin, and prices are a shade lower. There is also less fear of metal being lost through submarine operations. Tin has declined 2 cents locally, but is entirely nominal at 56 cents per pound.

Spelter.—The market is quiet and unchanged, but there is a firm undertone. Production is being seriously interfered with owing to the cold weather and another strengthening feature is the high cost of ore. Local price unchanged at 13½ cents per pound.

Lead.—A tight situation has developed in the market due to the scarcity of lead as a result of the freight congestion. The "Trust" is still quoting 8.50¢, but independents have jumped the price up to 10¢ and 10.25¢, New York, for spot metal. Lead has advanced 1¢ locally, and is now quoted at 12¢ per pound.

Antimony.—The market is firmer, but quotations are unchanged in the meantime. Considerable interest has been aroused by the refusal of leading sellers of antimony to issue quotations on fut-

vious year, it is satisfactory to be able to record that the growth in British exports was considerably in excess of the increase of imports. Whereas the increase in imports was 10.2 per cent., the advance in exports was 31.6 per cent."

Mr. Watson attributes the reduction in the adverse balance of trade, which commenced to be an alarming feature of British trade returns shortly after the outbreak of war, to the restriction of imports, and states: "It is difficult to see how imports can be further curtailed if the wants of the population are to be adequately met."

He gives praise to the British industrial system, which, though largely occupied with munition making, has been able to accelerate its production of commercial exports as well. As regards trade with Canada, he states: "It is satisfactory to see that in almost every item there has been a large and in some cases remarkable increase in the quantities received from Canada, the advance in valuation being proportionately much greater owing to the heavy rise in prices which has taken place."

Among the articles of import from the Dominion are: Wheat, \$76,000,000; flour, \$18,000,000; barley, \$9,000,000; maize, \$6,000,000; bacon, \$37,000,000; cheese, \$37,100,000. The export of bacon has nearly doubled as compared with 1915. Canadian lumber exports are growing also, and now constitute 20 per cent, of the whole total, as compared with 15 per cent, of former years.

Aggregate Trade

The aggregate trade of Canada during the period ended November, 1916, amounted to \$2,060,561,658, of which \$1,269,928,215 represented exports and \$790,573,443 imports. Canada thus enjoyed in the period a favorable balance of trade of \$479,354,772. Imports into Canada from the United Kingdom amounted to \$118,154,745 and from the United States merchandise to the value of \$572,730,816. Included in the exports of the Dominion were goods to the value of \$690,538,735, to the United Kingdom, and merchandise to the value of \$291,069,070, which went to the United States. Imports of coin and bullion amounted to \$46,170,398, while exports of the same totalled \$196,422,615, most of which went to the United States. Some indication of the expansion of trade may be gathered from the fact that in the 12 months ending November, 1915, the aggregate trade of the country was \$1,175,216,733, of which \$418,158,536 represented imports and \$727,058,197 represented exports.

EQUIPMENT NEEDS OF MESOPOTAMIA RAILROAD

THE Persian Gulf & Mesopotamia Development Co., which is now surveying a line from Bagdad, and which is connected with interests concerned in the management of important railroads in India, has, through J. S. Popper, New York City, issued a long list of equipment requirements for the railway and

CANADIAN GOVERNMENT PURCHASING COMMISSION

The following gentlemen constitute the Commission appointed to make all purchases under the Dominion \$100,000,000 war appropriation:—George F. Galt, Winnipeg; Hormidas Laporte, Montreal; A. E. Kemp, Toronto. Thomas Hilliard is secretary, and the Commission headquarters are at Ottawa.

ure shipments from China. It is understood that most of the producers there are sold up completely until April, and unless they could obtain assurance of freight space they would not offer any further tonnages. Local price 35¢ per pound.

Aluminum.—The market continues firm and unchanged at 68¢ per pound.

TRADE INCREASE WITH BRITAIN

A LARGE increase in imports from Canada is a feature of British foreign trade returns for 1916, according to a report received by the Trade and Commerce Department Ottawa, from Commissioner Harrison Watson, of London.

"The immediate impression created by the returns," says Mr. Watson, "is one of wonder that it has been possible for the United Kingdom to carry on a trade of such magnitude under every variety of adverse circumstances, and its accomplishment forms the highest tribute to Britain's command of the sea and her unimpaired financial strength and ability. While the total foreign trade for 1916 attained the colossal value of \$7,766,536,965, an increase of no less than \$1,087,400,000 over the pre-

Enlarged Canadian Trade Intelligence Service

Under the arrangement made by the Minister of Trade and Commerce with Sir Edward Grey in July, 1912, the Department of Trade and Commerce, Ottawa, is able to present the following list of the more important British Consulates whose officers have been instructed by the Foreign Office to answer inquiries from and give information to Canadians who wish to consult them in reference to trade matters.

BRAZIL —Bahia, British Consul. Rio de Janeiro, British Consul General.	NETHERLANDS —Amsterdam, British Consul.
CHILE —Valparaiso, British Consul General.	PANAMA —Colon, British Consul. Panama, British Vice-Consul.
COLOMBIA —Bogota, British Consul General.	PERU —Lima, British Vice-Consul.
ECUADOR —Quito, British Consul General. Guayaquil, British Consul.	PORTUGAL —Lisbon, British Consul.
EGYPT —Alexandria, British Consul General.	RUSSIA —Moscow, British Consul General. Petrograd, British Consul. Vladivostok, British Consul. Odessa, British Consul General.
FRANCE —Havre, British Consul General. Marseilles, British Consul General.	SPAIN —Barcelona, British Consul General. Madrid, British Consul.
INDIA —Calcutta, Director General of Commercial Intelligence.	SWEDEN —Stockholm, British Consul.
ITALY —Genoa, British Consul General. Milan, British Consul.	SWITZERLAND —Geneva, British Consul.
MEXICO —Mexico, British Consul General.	URUGUAY —Monte Video, British Vice-Consul.
	VENEZUELA —Caracas, British Vice-Consul.

Canadian Commercial Intelligence Service

The Department of Trade and Commerce invites correspondence from Canadian exporters or importers upon all trade matters. Canadian Trade Commissioners and Commercial Agents should be kept supplied with catalogues, price lists, discount rates, etc., and the names and addresses of trade representatives by Canadian exporters. Catalogues should state whether prices are at factory point, f.o.b. at port of shipment, or, which is preferable, c.i.f. at foreign port.

CANADIAN TRADE COMMISSIONERS.

ARGENTINE REPUBLIC —H. R. Poussette, Reconquista, No. 46, Buenos Aires. Cable address, Canadian.
AUSTRALIA —D. H. Ross, Stock Exchange Building, Melbourne. Cable address, Canadian.
BRITISH WEST INDIES —E. H. S. Flood, Bridgetown, Barbadoes, agent also for the Bermudas and British Guiana. Cable address, Canadian.
CHINA —J. W. Ross, 13 Nanking Road, Shanghai. Cable address, Cancom.
CUBA —Acting Trade Commissioner, Lonja del Comercio, Apartado 1290, Havana. Cable address, Cantracom.
FRANCE —Phillipe Roy, Commissioner General, 17 and 19 Boulevard des Capucines, Paris. Cable address, Stadacona.
JAPAN —G. B. Johnson, P. O. Box 109, Yokohama. Cable address, Canadian.
HOLLAND —Acting Trade Commissioner, Zuidblaak, 26, Rotterdam. Cable address, Watermill.
RUSSIA —C. F. Just, Canadian Government Commercial Agent, Alexandrivskaya, Ploshch 9, Petrograd. L. D. Wilgress, Canadian Government Commercial Agent, Bukhgozla Uliza No. 4, Omsk, Siberia.
NEWFOUNDLAND —W. E. Nicholson, Bank of Montreal Building, Water Street, St. John's. Cable address, Canadian.
NEW ZEALAND —W. A. Beddoe, Union Buildings, Customs Street, Auckland. Cable address, Canadian.
SOUTH AFRICA —W. J. Egan, Norwich Union Buildings, Cape Town. Cable address, Cantracom.
UNITED KINGDOM —Harrison Watson, 73 Basinghall Street, London, E.C., England. Cable address, Sleighing, London. N. D. Johnston, Sun Building, Clare Street, Bristol. Cable address, Canadian. J. E. Ray, Central House, Birmingham. Cable address, Canadian. J. Forsyth Smith, 27-28 Pearl Building, East Paradise, Leeds. Cable address, Canadian. F. A. C. Blekerdike, Canada Chambers, 36 Spring Gardens, Manchester. Cable address, Cantracom. J. T. Lithgow, 87 Union Street, Glasgow, Scotland. Cable address, Cantracom.

SPECIAL TRADE COMMISSIONER—LUMBER

H. R. McMillan, visiting Europe, Africa, Australasia and the Orient.

CANADIAN COMMERCIAL AGENTS

AUSTRALIA —B. Millin, Exchange Building, Sydney, N.S.W.
BRITISH WEST INDIES —Edgar Tripp, Port of Spain, Trinidad. Cable address, Canadian. R. H. Curry, Nassau, Bahamas.
NORWAY AND DENMARK —C. E. Soutum Grubbedg No. 4, Christiania, Norway. Cable address, Soutums.

CANADIAN HIGH COMMISSIONER'S OFFICE

UNITED KINGDOM—W. L. Griffith, Secretary, 17 Victoria Street, London, S.W., England. Cable address, Dominion, London.

is asking various car and locomotive builders if they can meet the required deliveries. The equipment will be taken in installments over a period from September, 1917, to 1921, and includes the following:

Three hundred and thirteen passenger locomotives, 863 goods locomotives, 78 locomotives for mixed passenger and goods trains.

Four saloon and state cars, 85 reserved carriages, 11 dining cars, 75 first class carriages, 145 composite first and second carriages, 152 composite, first, second and third class carriages, 45 other carriages.

Fifty-seven second class carriages, 126 intermediate class carriages, 221 composite and intermediate and third class carriages. Five hundred third class without brakes, 653 third class ambulance carriages, 17 third class ambulance carriages with brakes, 80 third class and postal carriages.

Three hundred and eighteen passenger brake vans, 19 brake vans with postal compartment, 4 postal vans, 54 carriage brakes, 150 horse boxes, 44 luggage vans, 164 miscellaneous, 18 stores vans.

Twelve thousand two hundred and eighty-two covered goods wagons, 2,578 high-sided wagons, 553 low-sided wagons, 8 cattle trucks, 12 platform wagons, 64 powder vans, 242 timber trucks, 267 bolster trucks, 240 ballast wagons, 399 brake vans (all uses).

Ninety-two oil tanks, 79 water tanks, 35 gas holders, 68 cranes, 16 miscellaneous items, special work, etc., 232,000 tons of 65-pound steel rail, 4,000,000 creosoted pine ties.

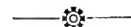

THE EXPORT ASSOCIATION OF CANADA

THE Export Association of Canada Montreal, in its annual report, urges upon the business community of Canada the necessary for the immediate study of the economic problems which Canada must face after the war. Over 600 Canadian factories are completely utilized with munitions orders, and 400,000 Canadian workers are making war equipment. During the year the association placed with Canadian manufacturers 871 orders, totalling in value \$734,000. An attempt was made to organize a campaign in Siberia, but the project was abandoned owing to the rigid embargo placed upon traffic at the port of Vladivostok. The cost of operation during the year was, roundly, \$34,000. The trading profits amounted to about \$19,000, leaving a deficit of \$15,000. The deficit has been partly offset by subscriptions to stock amounting to \$7,500. The present available capital for operating is \$37,621.83. The officers for the new year are: President, J. H. Sherrard; vice-president, R. Montague Davy; executive committee, J. H. Sherrard, R. Montague Davy, R. H. McMaster, R. E. Thorne and Paul Joubert.

The A. R. Williams Machinery Co., Limited

TORONTO

St. John, N.B.

Winnipeg

Vancouver

Write us about—

LEBLOND	Heavy Duty Lathes and Milling Machines
HENDEY	Tool Room Lathes and Millers
CISCO	Lathes "with the pull"
WARNER & SWASEY.....	Turret Lathes and Screw Machines
GOULD & EBERHARDT.....	Shapers and Gear Cutting Machines
SMITH & MILLS.....	Shapers exclusively
FOSDICK	Heavy Duty Radial Drills
BAKER	Heavy Duty Drills and Boring Machines
W. F. & JNO. BARNES.....	Drills and Lathes
LELAND GIFFORD.....	High Speed Sensitive Drills
HENRY & WRIGHT.....	Sensitive Drills
LANDIS	Plain and Universal Cylindrical Grinders
BLANCHARD	Vertical Surface Grinders
DIAMOND	Grinders (all types)
WILMARTH & MORMAN.....	New Yankee Grinders
CONSOLIDATED	Presses

"If It's Machinery Write Williams"



TAPER THREADS EASILY CUT

With a Geometric Taper Threading Die Head one gets the same rapid production and superior finish that mark all Geometric threads. The chasers follow the taper of the work automatically, and release the work at the end of the cut. Head is withdrawn without touching the finished threads.

Geometric Taper Threading Die Heads are adapted to Screw Machine and Turret Lathe. When not cutting taper threads, the Head can be removed, leaving the machine free for other work. Made to order, specially suited to requirements of machine and work. Employed very generally on fuse work. Give the Geometric finish to your taper threads.

It will cost you nothing to get our quotation on your specifications. May we have them?

THE GEOMETRIC TOOL CO.

NEW HAVEN, CONN., U.S.A.

Canadian Agents:— Williams & Wilson, Ltd., Montreal.
The A. R. Williams Machinery Co., Ltd., Toronto.
Winnipeg and St. John, N.B.

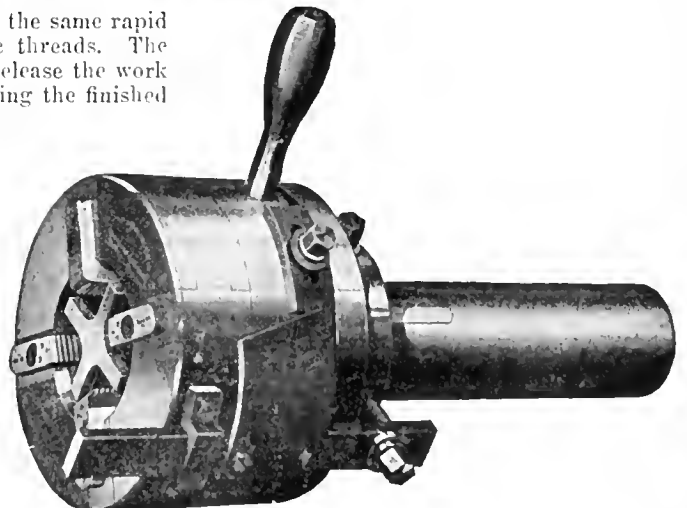

A Geometric Taper Threading Die Head.

If any advertisement interests you, tear it out now and place with letters to be answered.

INDUSTRIAL ^A_N^D CONSTRUCTION NEWS

Establishment or Enlargement of Factories, Mills, Power Plants, Etc.; Construction of Railways, Bridges, Etc.; Municipal Undertakings; Mining News

ENGINEERING

Amherst, N.S.—The Maritime Coal, Railway & Power Co., contemplate purchasing pumps, motors and electrical equipment.

Vancouver, B.C.—The Maritime Motor Co., has been formed here to manufacture a special type of mining and logging locomotive, driven by gasoline engine.

Toronto, Ont.—The Queen City Foundry Co. plant on Cherry street, was gutted by fire on Monday morning. All the equipment was destroyed and also the patterns. The loss is estimated at \$60,000 which is only partially covered by insurance.

Kitchener, Ont.—V. O. Phillips & Sons, of this city, have made application for a permit to erect a new addition, 60 by 100 feet, to the plant of the Twin City Oil Co., for the purpose of manufacturing a visible gasoline pump having purchased the Canadian rights.

Toronto, Ont.—It is reported that the Nathan Manufacturing Co. of New York may establish a factory in Canada for making locomotive accessories. O. Best manager of this concern's New York factory is investigating business conditions in Canada with the above object in view.

Lindsay, Ont.—Flavelle's Ltd., cold storage building will be re-built. The new plant will comprise a creamery and egg house having a total refrigeration capacity of about 25,000 cub. feet. The Canadian Ice Machine Co., Toronto are supplying the new equipment which will consist of brine coolers, condensers and over 20,000 feet of 2 in., ammonia piping for the cooling rooms.

The British American Nickel Corporation are having plans prepared for the first unit of a large nickel refinery to be built at Murray Mine about three miles from Sudbury, Ont. The initial unit will cost approximately \$1,500,000 and will consist of two blast furnaces, three converters and power plant. There will be buildings comprising the smelter building, machine and blacksmith shops, power house, etc. The buildings will be of brick and steel construction requiring about 2500 tons of steel. The company propose using about 5000 h.p. hydro-electric power, and all the machinery will be driven by electric motors. The power plant equipment will consist of two 30,000 cub. ft. 12 lbs. pressure air compressors for the converters, two blowers, of 30,000 cub. ft. capacity at 40 ounces pressure, for the blast furnaces, motor generators, switchboard, 1000 h.p. water tube boilers, pumps, etc. The construction plant is being assembled, and building will start in the early

spring. F. T. Brule, Royal Bank Building, Toronto, is the engineer, for the company and is preparing the plans.

The Port Arthur Pulp and Paper Co., propose building a mill probably at Port Arthur, Ont., but in the meantime the work is being held up. The plans call for a total expenditure of \$2,000,000 but the initial unit will cost in the neighborhood of \$500,000. The mill will have a daily capacity of 50 tons of sulphite pulp, but at a later date a book paper mill will be erected. The buildings will be of brick and reinforced concrete construction with steel roof trusses. About 1000 h.p. of electrical energy will be required for driving the machinery, and three 375 h.p. boilers will be installed for steam heating, also for manufacturing purposes. Other equipment required will include wood and steel tanks, and storage vats, electrical equipment and log conveying machinery. T. H. Weldon and S. F. Duncan of the Provincial Paper Mills, Toronto, are interested, and A. G. Pounsford is general manager.

ELECTRICAL

Windsor, Ont.—Officials of the Canadian Steel Corporation have made application to the Ontario Hydro-Electric Commission for a supply of Niagara power, according to Chairman Shepherd, of the Windsor Hydro-Electric Commission.

Chatham, Ont.—A proposition will probably be endorsed by the Provincial Hydro Commission whereby it is proposed that the city purchase the Electric Department of the Chatham Gas Co. for \$115,000, thus removing competition with Hydro.

Toronto, Ont.—Scarborough Township Council, at their meeting on February 12, passed a by-law authorizing the issue of debentures to the value of \$18,500 to finance the installation of a Hydro-Electric system in that part of the township extending from the limit of the City of Toronto to the town of Agincourt.

MUNICIPAL

Chatham, Ont.—It is proposed to give \$5,500 by way of a bonus to the Libby, McNeill & Libby Co., of Canada.

Grimsby, Ont.—The ratepayers have granted a loan of \$6,000 to the Metal Craft Co., which will erect a plant there.

Montreal, Que.—The bids received on Feb. 12 for street cleaning machinery, amounting to \$160,000, have been rejected. New tenders will be called on Feb. 26. The equipment required consists of twenty flushers and sweepers for the street cleaning department.

Hamilton, Ont.—The Board of Control contemplate the purchase of a motor driven street flusher and an aerial truck.

Midland, Ont.—A by-law will be submitted to the ratepayers on March 3 to authorize a \$25,000 bonus to the Midland Dry Dock Co.

Montreal, Que.—According to an order issued by the Provincial Board of Health, the towns of Ste. Anne de Bellevue, Pointe Claire and Dorval must install filters, as the water in Lake St. Louis is unfit to drink.

Horton Township, Ont.—A by-law will be voted on by the ratepayers on March 2, to authorize a power company, of which M. T. O'Brien is at the head, to erect transmission lines in the township.

Gleichen, Alta.—A by-law will probably be submitted to the ratepayers to ascertain their opinion on the purchase of the local electric light plant, now privately owned. The proprietor offers the plant for \$6,000, and will accept the town's debentures for the amount.

Winnipeg, Man.—The Board of Control have decided to replace all rigs in the waterworks department by motor trucks not later than June 1. Tenders are to be at once called for three to three and a half-ton trucks, also for five-ton trucks. These will be fitted with automatic tips and knives for snow plowing.

Toronto, Ont.—Tenders have been received for the supply of cast iron pipe, water meters, hydrants and valves for the proposed waterworks system for York Township. The firms tendering included the National Iron Works, Canadian Allis-Chalmers, Ltd., Drummond McCaul Co., R. D. Wood Co., Simplex Meter Co., and Builders' Iron Foundry.

BUILDINGS

Calgary, Alta.—The Federal estimates provide for \$250,000 for the completion of the drill hall here.

Hamilton, Ont.—The Canadian Westinghouse Co. will build an office building to cost \$150,000. Praek & Perrine, Toronto, are the architects.

Hamilton, Ont.—The Technical Committee of the Board of Education has practically decided not to proceed with the erection of the new technical school on Wentworth street until after the war.

Toronto, Ont.—A building permit was granted by the city architect to the Harry Webb Co., to erect a two-storey brick bakery at the southwest corner of Kendall avenue and Davenport road, at a cost of \$60,000.

Aikenhead's

Advantages---

secured by the use of this machine as compared with a reciprocating filing machine for finishing blanking dies:—

1. Work drawn down on table or platen.
2. A wide range of surface contours finished without change of cutters.
3. Surfaces finished with uniform degree of clearance regardless of direction from which work is applied to cutter.
4. Chips carried downward, not deposited on top of the die to obscure the pattern or layout.
5. Will remove very much more material in a given time than is possible with a reciprocating file.

Write for catalog and full information.

Aikenhead Hardware, Limited

17, 19, 21 Temperance Street, Toronto, Canada

Anderson Die-Forming Machine

*means larger and better
production*

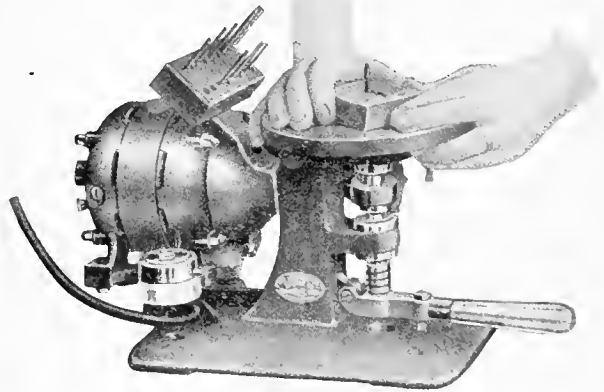

MAKE YOUR DOLLARS

FIGHT

AT THE FRONT.

BUY

DOMINION OF CANADA

THREE-YEAR

WAR SAVINGS CERTIFICATES

\$ 25.00	FOR	\$21.50
50.00	"	43.00
100.00	"	86.00

INDIVIDUAL PURCHASES LIMITED TO \$1500.

FOR FULL PARTICULARS APPLY AT ANY BANK
OR ANY MONEY ORDER POST OFFICE

JAN. 9, 1917

FINANCE DEPARTMENT
OTTAWA

METAL STAMPINGS

We are manufacturers of stamped parts for other manufacturers.

We do any kind of sheet metal stamping that you require. Our improved presses and plating plant enable us to produce the finest quality of work in a surprisingly short time.

We can finish steel stamping in Nickel, Brass or Copper.

Send us a sample order.

W. H. BANFIELD & SONS

372 Pape Avenue, Toronto, Can.

If any advertisement interests you, tear it out now and place with letters to be answered.

Long Wear and Rapid Cutting are Features of Delta Files

These features mean a saving in time and reduced file expenses.

The extra durability of Delta Files means a surprising curtailment in file expenses when the accumulating results of a year's use of these files in your shop are considered.

DELTA FILES

cut faster and outlive any other file made, because they retain their cutting edges longer.

There is a Delta File for every purpose, and a Delta File means a time-saving on every man that uses one. Made absolutely of crucible steel and the only files made in lengths from 3 to 24 inches long.

We will send you a sample file to enable you to prove these features to your own satisfaction. Ask for your sample.



DELTA FILE WORKS

PHILADELPHIA, PA., U.S.A.

CANADIAN AGENTS:

H. S. Howland, Sons & Co., Toronto;

Starke, Seybold, Montreal;

Wm. Stairs, Son & Morrow, Halifax;

Marrick-Anderson Co., Winnipeg

All Leading Jobbers.

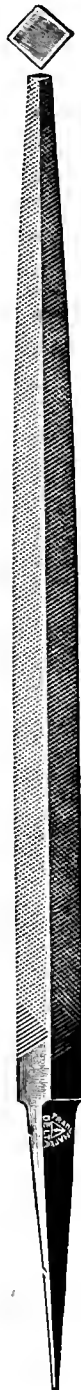

Hamilton, Ont.—At a special meeting of the Board of Education, it was decided to proceed with the erection of a ten-room addition to the Adelaide Hoodless School, at a cost of \$63,907. The lowest tenders in each case had been accepted.

Orillia, Ont.—A by-law to raise by debenture \$18,000 for the completion of a new municipal building was carried on Feb. 12, by 98 majority. The vote was small. The original by-law carried a year ago was for \$35,000. It is expected the new building will be opened early in March.

New Westminster, B.C.—In preparation for an early start on the construction of the N. P. freight warehouse on the waterfront, the contractor, H. W. Harrison, is having the various preliminaries arranged. Mr. Harrison has let a sub-contract for 19 steel rolling doors for the warehouse to T. J. Trapp & Co., Ltd. They will cost in the neighborhood of \$4,000.

Winnipeg, Man.—Tenders for the completing of the new Parliament Buildings were opened on Feb. 12 by Thos. H. Johnson, Provincial Minister of Public Works. The lowest tender on the main contract was submitted by the George A. Fuller Co., the price being \$1,171,823. Tenders were also sent in by the James Ballantyne Co., for the heating and ventilating, at \$170,700; the Mundy, Rowll Co., for electric conduit and wiring at \$101,036. The grand total for the new work is \$2,230,902, which, in addition to the amount already expended of about \$2,364,000, makes the total cost \$4,594,902.

INCORPORATIONS

Superior Electric, Ltd., has been incorporated at Ottawa with a capital of \$100,000 to manufacture electrical appliances of all kinds at Pembroke, Ont. The incorporators are John H. Reeves, L. S. Mackie and James R. Lockhart all of Pembroke, Ont.

The Aspinwall Canadian Co., has been incorporated at Ottawa with a capital of \$75,000 to manufacture machinery, motors and mechanical appliances of all kinds at Guelph, Ont. The incorporators are Lawrence Jacques, Allen E. Turner and Nicol Geoffrey all of Guelph, Ont.

Paint Products Co. of Canada, Ltd., has been incorporated at Ottawa with a capital of \$500,000 to extract and prepare minerals and deposits for the manufacture of paints, etc. The head office is at Montreal and the incorporators are J. B. D. Legare, Armand Mathiew and Robert T. Mullin all of Montreal.

Ford Tractor, Co. of Canada, Ltd., has been incorporated at Ottawa with a capital of \$10,000,000 to manufacture motor tractors, machinery and equipment in connection with same also to take over the patent rights within the Dominion of the Ford Tractor. The head office is at Toronto and the incorporators are H. G. Keen, John F. Boland and E. P. King all of Toronto.

TENDERS

Toronto, Ont.—Tenders, addressed to the chairman of the Toronto Electric Commissioners, will be received until March 28, for synchronous condensers. Specifications may be obtained at the office of the purchasing agent, 15 Wilton Avenue, Toronto.

Windsor, Ont.—Tenders will be received by the engineer R. W. Code, up till March 1, for supplying all labor, tools and materials necessary for the construction and completion of one cast iron intake and concrete well for the Eau Claire Waterworks Co., Tecumseh, Ont., according to plans and specifications prepared by R. W. Code, C. E. Windsor.

Winnipeg, Man.—Tenders will be received up to March 15, by R. D. Waugh Chairman of Commissioners, Greater Winnipeg Water District, for the supply of approximately 12,500 feet of 48-in. and 1,300 feet of 60-in. cast iron pipes, together with specials and gate valves. Specifications on application to the offices of the District, 501 Tribune Building, Winnipeg.

Toronto, Ont.—Tenders will be received, addressed to the Chairman, Board of Control, City Hall, up to Feb. 27, for the construction of a drainage system (wrought iron pipe), for the Rosedale Bridge, Bloor Street Viaduct. Specifications and forms of tender may be obtained upon application at the Bloor Street Viaduct field office, 89 Castle Frank Road, Toronto.

Windsor, Ont.—Tenders will be received up to Feb. 28, 1917, for the construction of the superstructure of:— (a) One 70-foot clear span bridge. (b) One 80-foot clear span bridge. (c) Two 100-foot clear span bridges. Plans and specifications may be seen at the office of J. J. Newman, Davis Block, Windsor, Ont., or at the office of H. J. Rocheleau, Stoney Point, Ont.

Windsor, Ont.—Tenders will be received up to March 1 by R. W. Code, Board of Trade Building, Windsor, Ont., engineer, in connection with the erection of waterworks to cost \$20,000, by the Eau Claire Waterworks Co., Tecumseh, Ont., for two centrifugal pumps and motors installed complete of 250 gallons per minute capacity. Specifications and all details at office of R. W. Code, engineer.

Hamilton, Ont.—Tenders will be received by the Board of Control up to March 5, for the supply of ordinary and special castings, iron pipe, hydrants, valves, extension boxes. Lead pipe—pig lead, rubber hose, rubber boots, road oil, lubricating oil, flux, fuel oil, coal oil, gasoline, brass work, including ordinary and special brass castings for water department, hardware, etc. Specifications may be obtained at the office of E. R. Gray, city engineer.

Winnipeg, Man.—Tenders, addressed to the Chairman, Board of Control, will be received up to February 26, for the supply f.o.b. Winnipeg, freight and duty paid, of from one to three gasoline or

electric driven motor trucks or from two to five-ton weight, with two or four-wheel drive, body capacity not less than six cubic yards, and with or without crane attachment capable of lifting 500 lbs. Information for bidders may be obtained at the office of the Street Commissioner, corner James Avenue and King Street, Winnipeg.

PERSONAL

John H. Bunting, joint manager of Bruce Peebles & Co., Edinburgh, Scotland, has been appointed general manager of the company.

Harry McLaughlin, surveyor of customs at Montreal, has been appointed shipping master of that port in succession to R. S. White, resigned.

Charles J. Stark, of New York, has been appointed editor of the *Iron Trade Review*, and will shortly assume his new duties at Cleveland. Mr. Stark has been connected with the editorial staff of this journal for over a decade, having been associate editor both in Pittsburg and in New York City.

Capt. Reginald B. Bassett, member of the Lake Masters' Association, died at the residence of his parents, 24 Tyndall Avenue, Toronto, on February 17. He was born at Collingwood, Ont., 33 years ago. Previous to sailing the *Mariska* for the Bassett Steamship Co., he was master of the *J. A. McKee*, belonging to the Western Steamship Co.

Captain Robert A. Bartlett, Peary's navigator of the Roosevelt on the successful expedition to the North Pole in 1909, will go again into the Arctic Ocean in 1918, and is now preparing plans for a wooden ship, 135 feet long, to be built in one of the yards on the Pacific Coast. Bartlett will inspect the yards on the Pacific this spring and select a site for the building of his vessel.

TRADE GOSSIP

Goldie & McCulloch Co., Galt, Ont., have been awarded a contract for three 350 h.p. boilers for the Middlesex Mills Co., London, Ont.

Iroquois Falls, Ont.—The Abitibi Power & Paper Co. new sulphite mill will, it is understood, be operating by May. The new paper machines will double the company's output of newsprint before the end of the year.

The **Taylor Engineering Co.**, of Vancouver, B.C., are handling the Bolinder crude oil engine which is built in Stockholm, Sweden. Twenty-four engines of this type have already been sold to shipbuilding firms in British Columbia.

Heap & Partners, Ltd., Montreal, has been changed to Samuel Osborne & Co. The company has secured a factory on Seigneurs Street, Montreal, and has equipped it for producing high-speed tool steel. S. C. Burk is superintendent.

The **General Machinery & Equipment Co.**, Vancouver, B.C., has opened offices in the Birks Building, that city. The firm will handle a general line of contractors' and mining equipment, also railway sup-

We are qualified Tool, Die, Jig, Gauge and Fixture Makers.

WRITE US.

Windsor Machine & Tool Works.
WINDSOR, ONT.

MORTON MANUFACTURING CO.
PORTABLE PLANERS
DRAW CUT SHAPERS
SPECIAL DRAW CUT R R SHAPERS
FINISHED MACHINE KEYS
STATIONARY & PORTABLE KEY WAY CUTTERS
SPECIAL LOCOMOTIVE CYLINDER PLANERS
OFFICE AND WORKS: MUSKOGON HEIGHTS U.S.A.



An Ideal Locker for Clothes and Personal Tools

This combination Tool and Clothes Locker will be very useful to the mechanic because it provides ample space for clothes and a safe place for his tools.

Built for life-time service. Supplied in unit or group construction.

We also manufacture **STEEL SHELVING FOR ALL PURPOSES.** Drop a line for full details.

CANADA WIRE & IRON GOODS CO.

HAMILTON ONTARIO
Eastern Representative: H. E. O. Bull
184 Mance St. Montreal, P. O.

OVENS
Enamelling and Varnishing Ovens heated by Gas, Electricity, Steam or Coal. Write for Booklet.
Brantford Oven & Rack Co., Ltd.
Brantford, Canada.

Oxy-Acetylene Welding
We can give the best of service in all kinds of welding repair jobs. We have successfully repaired the most difficult jobs. Our work is high-class and our prices moderate.
Send us your work or write us regarding it.
TORONTO WELDING CO.
26 Pearl St., TORONTO

GAUGES
DIES, TOOLS AND REPAIRS
OXY-ACETYLENE WELDING
WORTH ENGINEERING CO.
163 Spadina Ave., Toronto, Ont.
Phone Adel. 3734
B. H. AYLSWORTH A. E. HACKWORTH

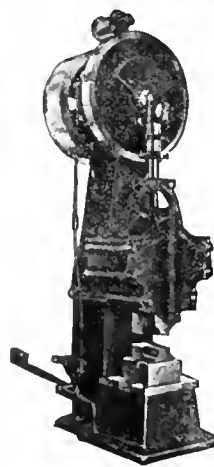

The **"Dupont" PATENT Power Hammer**

The strength, durability, economy of power and simplicity of adjustment of the Dupont Power Hammer make it a decidedly superior tool.

Made carefully from carefully selected, high-class materials.

Positively **7** Guaranteed

Seven sizes.

With rams from 35 to 300 lbs.

Write for full details.

THE PLESSISVILLE FOUNDRY

Plessisville, Que.

Ontario and Western Agents:
The General Supply Co. of Canada Ltd.
Ottawa Toronto Winnipeg

PATENT ATTORNEYS

BABCOCK & SONS

ESTAB. 1877

PATENTS-TRADE MARK-DESIGNS
IN ALL COUNTRIES

Book "Patent Protection"—free. Master of Patent Laws, Formerly Patent Office Examiner.

99 St. James St., - Montreal, Que.
Branches: Ottawa, Washington.

RESEARCH BUREAU

REPORTS BY EXPERTS ON SCIENTIFIC, TECHNICAL AND INDUSTRIAL DEVELOPMENT.
SPECIAL RESEARCHES ARRANGED.

PATENTS, TRADE MARKS, ETC.

HANBURY A. BUDDEN * CABLE ADDRESS
712 DUMFRIES BLDG. MONTREAL "BREVET"

PATENTS

Fetherstonhaugh & Co.
Patent Solicitors, Head Office,
Royal Bank Bldg., Toronto,
Ottawa Office, 5 Elgin St.
Send for our Plain Practical
Pointers. Copy of National
Progress, in which our patents
are advertised, mailed free.

PATENTS PROMPTLY SECURED

In all countries. Ask for our Investor's Adviser, which will be sent free.

MARION & MARION, 364 University St.

Merchants Bank Building, corner
St. Catherine St., MONTREAL, Phone Up. 6474
and Washington, D.C., U.S.A.

SPECIAL MACHINERY

GAUGES, FIXTURES, DIES
AND
PRECISION TOOLS

WE HAVE THE
MOST MODERN
EQUIPMENT
TO HANDLE
ANY CLASS OF WORK

CANADIAN DISTRIBUTORS FOR THE
ALBANY PATENT ROTARY
PUMP

Albany Pump Co.

16 Pearl St., TORONTO, Canada
Phone Ad. 2511 A. W. Bennet, Manager

plies. John MacKenzie is managing director of the company.

The Armstrong Whitworth Co., of Canada, Ltd., Montreal, have opened a branch at 27 King William street, Hamilton, Ont., where stock will be carried to take care of their Ontario trade. The Hamilton office will be under the management of F. T. Malone.

Ottawa, Ont.—The Government is sending overseas shortly six more portable sawmills for the preparation of lumber for use on the western front. Already a number of such mills have been sent abroad with forestry units, and have given satisfaction.

Canadian S. K. F. Co., has been organized under Dominion Charter for the manufacture and sale of S. K. F. self-aligning ball bearings in Canada. All correspondence should be directed to Toronto in which city headquarters have been established at 47 King street, West.

Drastic Embargo on Imports.—Andrew Bonar Law, Chancellor of the Exchequer, stated in the House of Commons that the British Government had decided upon very drastic restrictions on imports. The new measures, he added, would affect the Allies of Great Britain and the British Dominions.

Montreal, Que.—The Southern Canada Power Co., in extending its system throughout the Province of Quebec, has taken over the Brome Lake Electric Company, supplying the towns of Waterloo, Knowlton, Foster, etc. The company is now supplying light and power to 35 cities and towns in the province.

U.S. Navy Shell Orders.—The United States Navy Department has awarded a contract for 15,000 14-inch shells at \$500 each to the Midvale Steel Co., the Crucible Steel Co., and the Washington Steel and Ordnance Co., each company getting practically one-third of the award. These are the contracts which Hadfields Ltd., were not allowed to accept.

Newsprint Paper Reduced.—An official statement was issued at Ottawa last Saturday with regard to the fixing of a maximum price for Canadian newsprint, as sold to newspapers in the Dominion. The statement announces that the pulp and paper manufacturers, with whom the matter has been left, will determine their course on Wednesday.

The Export Association of Canada, Montreal, has directed its general manager, R. J. Younge, to proceed to South Africa as soon as possible to open up trade connections in that market for the members of the association. Mr. Younge will leave just as soon as he can gather together the necessary information from those firms who are interested—probably next month.

Russia Will Build Mercantile Fleet.—A despatch to Renter's Telegram Co., London from Petrograd says the Russian Minister of Commerce has introduced in the Duma a bill under the terms of which the Government will devote 100,000,000 roubles toward the creation of a Russian mercantile fleet.

The money is to be employed in advances to shipbuilders to encourage the construction of new shipyards and to provide equipment for them.

Enquiry for Track Material.—Albert Frost & Co., Sheffield, England, are open to purchase track materials as follows: 1,000 tons of flat bottom rails, 18 lbs. per yard section, punched for nails, and in 6 ft. and 9 ft. lengths; 50,000 gross eub. sq., bolts and nuts, 5-16 and 3/8 in.; 250 tons railway spikes 2 1/2 in. and 3 in. by 5-16 in. and 3/8 in.; 250 tons wire nails, 2 1/2 in. by 5-16 in., and 3 in. by 5-16 in. Delivered f.o.b. English port. Lists and full particulars to be mailed in advance.

Investigating Niagara Development.—It is stated that a corps of engineers is engaged upon an examination and inspection of all power company plants at Niagara Falls, Ont., with a view to determine for the Ontario Government if the water is being utilized with a proper degree of efficiency or economy. It is believed that this may have an important bearing upon the production of power upon the Canadian side, to meet Hydro and other demands.

The S. Morgan Smith Co., York, Pa., have closed a contract with the Saguenay Light & Power Co., Chicoutimi, Que., for two turbines, each of 2,500 h.p., to be direct connected to generators, and one turbine of 175 h.p. for an exciter unit. The turbines will work under a head of 53 feet. They are to be fitted with Lombard oil pressure governors. The present plant consists of one generator turbine and one exciter turbine of the same capacity as the new equipment ordered.

Russian Iron and Steel.—The production of pig-iron in Russia during 1915 was 4,062,100 tons, as compared with 4,769,300 tons in 1914. The output of semi-finished steel was 4,539,100 tons, as compared with 5,508,800 tons; and that of finished steel 3,590,500, as compared with 4,334,100 tons. Of the semi-finished and finished steel, 60 per cent. was produced in Central Asia, while the Ural region made 20 per cent. Of the pig-iron made in Russia in 1915, rather more than 70 per cent. was produced in Central Russia.

Market for Ships.—A representative of a large shipbuilding company now in New York, says France and Great Britain are in the market for all ships the shipbuilding companies can turn out. This is the first time in history that Europe has asked this country to supply ship tonnage. American shipbuilding companies are crowded with work, and few ships can be built for foreign countries. The same shipbuilder says this country will be kept busy turning out ships at least five years after the end of the European war.

Marine Association Elect Officers.—The annual meeting of the Dominion Marine Association was held last Thursday at the King Edward Hotel. A. E. Burke, the retiring president, presented the annual report of the association.

A. A. Wright, of the Montreal Transport Co., was elected president for the ensuing year, and will have J. T. Mathews, of Toronto, as his first vice-president, with A. E. Mathews, of the Mathews Steamship Co., acting as second vice-president. Francis King, of Kingston, was re-elected secretary.

B. C. Lead Production.—The lead production of Canada is almost wholly derived from British Columbia, the production of which is about 65,000,000 pounds a year. This metal is at present produced almost entirely from the mines of East and West Kootenay. The ores are smelted at Trail smelter, and the lead is refined there. On the coast and along the route of the G. T. P. are important deposits of lead ores which cannot be economically treated for want of smelting accommodation on the coast. The establishment of a lead smelter and refinery on the coast is, therefore, a necessity to the development of ore deposits tributary thereto.

Industrial Council Meets.—Sittings were held at Ottawa last week by the advisory council for scientific and industrial needs, appointed by the Government in November. Dr. A. J. MacCallum, presided over the sessions and members of the council in attendance included Dr. F. D. Adams, McGill president; W. C. Murray, University of Saskatchewan, Saskatoon; President A. S. MacKenzie, Dalhousie University, Halifax; Dr. R. F. Ruttan, McGill, Montreal, and Prof. J. C. McLennan, Toronto University. Organization work has been engaging the attention of the members of the council but steps are being taken to institute a number of inquiries which will be of benefit to the industrial development of the Dominion.

Electrolytic Refining of Copper.—The essential feature of electrolytic refining of copper is cheap hydro-electrical power, which is abundantly available in British Columbia, and smelting and refining plants to treat the ores now exported are required. The production is about 25,000,000 pounds per annum, and is capable of considerable increase. There is one refinery operating an electro-chemical process at Trail with a capacity of about 15,000,000 pounds spelter per annum. Another small refinery is being installed in the interior, Nelson. Nearly all the zinc ores are now produced in the interior, and the excess production over present refinery capacity, amounting to 10,000,000 pounds, has to be exported.

Coal Transports Heavy.—According to figures supplied by the Department of Customs at Ottawa there came into Canada in January, 1917, 30,440 tons of anthracite and 483,947 tons of bituminous more than in 1915, and yet there was no shortage in 1915. Conditions were somewhat similar in January, 1916, when 5,258 more tons of hard coal came in than this January. In January, 1917, 300,836 tons of anthracite, 217,339 tons of bituminous black and 814,380 tons bituminous lump coal were imported. In January, 1915, the 270,396 tons of hard coal that came

WM. MUIR & CO., LIMITED
 Manchester, England.
 Machine Tool Makers.
Specialties: Patent Puncher Slotting Machines, Milling Machines, Boring Machines.
Agents: Messrs. Peacock Bros., 65 Beaver Hall Hill, Montreal.
 Send for catalogue.

JOHN STIRK & SONS, Limited
 HALIFAX, ENG.
MACHINE TOOLS
Agents—The A. R. Williams Mcy. Co., Ltd.
 Toronto, Winnipeg, Vancouver, St. John, N.B.

BERTRAMS LIMITED
 Engineers
 Sciennes, EDINBURGH
 PAPER MILL MACHINERY
 and
MACHINE TOOLS for IRON WORKERS
 Catalogues offered to Purchasers.

WIRE SPRINGS
 OF ALL KINDS
 Machine Springs, Valve Springs, Automobile Cushion Springs, etc., of a quality that defies competition. Tell us your requirements. Send sample or specification for price.
JAMES STEELE, LIMITED
 QUELPER, ONTARIO

Quality is Highest—Not the Price
Dickow's Guaranteed 10-Inch Universal Index Centers
 You save from \$50 to \$125 on first cost, and many times that because of their simple construction and great ease of operation. They embody the maximum of accuracy, simplicity and durability.

Get the Original—Beware of Imitators
 Sold by all dealers. Write to-day for particulars
 Fred. C. Dickow, 35 So. Desplaines St., Chicago, Ill., U.S.A.

Oil Tempered Steel Springs
 —for every purpose and the best for each use.
 Special styles of all kinds to order.
THE CLEVELAND WIRE SPRING COMPANY
 Cleveland, Ohio
 U.S.A.

BOLTS
 Our large stock of Machine Bolts, Rivets and Washers assures quickly filled orders and prompt shipment. One quality only—The Best.
 Send a trial order.
LONDON BOLT & HINGE WORKS
 London Ontario

Special Machinery
 MADE TO ORDER
 Mill Machinery, Engine Work
 Grey Iron and Brass Castings
 TRY US FOR GENERAL REPAIRS
ALEXANDER FLECK, LIMITED
 (Vulcan Iron Works) OTTAWA, ONT.

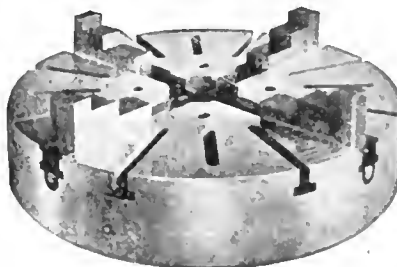
We Know
 you are anxious to buy
Canadian Made
 goods.
The Imperial

Chuck
 is manufactured by
Ker & Goodwin
 Brantford, Canada

MAPLE LEAF
STITCHED COTTON DUCK
BELTING
DOMINION BELTING CO. LTD.
HAMILTON CANADA

into Canada was valued by the Customs authorities at \$1,273,162, or about \$4.71 a ton. In 1916, 295,578 tons were valued at \$1,373,605, or about \$4.65 a ton. The 300,836 tons that came in last month are valued at \$1,572,882, or \$5.23 a ton.

London, Ont.—The Canadian Cereal & Flour Mills Co. has disposed of its 400-barrel mill at London, to the Quaker Oats Co., of Peterborough, Ont. The Quaker Oats Co. has also purchased a 300-barrel mill at Neepawa.

Uses of Molybdenum.—The greater demand for molybdenum since the outbreak of the war on account of its use in hardening steel was dwelt upon by Mr. G. C. Mackenzie, B.Sc., of the Department of Mines, Ottawa, in a lecture given on Saturday night before the Royal Canadian Institute, Toronto. Australia and Norway were formerly the two greatest producers of the mineral, said Mr. Mackenzie, but the demands made upon Canada and her deposits of the metal were bidding fair to make the Dominion the largest producer. Mr. Mackenzie went on to describe the method of separating the mineral from the ore. Deposits had been found in British Columbia, Ontario and Quebec, and one company at Orillia, Ont., was making special advances in the manufacture of by-products from the mineral.

RAILWAYS—BRIDGES

St. John, N.B.—The St. John Street Railway Co. will sell out to the New Brunswick Investment Co., a holding company organized for the purpose of making the purchase and it in turn will make a transfer to the New Brunswick Power Co. The latter controls water powers at Magaguadavic and Lepreaux and it is their intention to operate by hydro electric power instead of generating electricity by steam as at present. Prospective purchasers also plan considerable extension of the lines and introduction of more modern methods in operation of the company.

CONTRACTS

Merrittton, Ont.—The Robertson Cataract Electric Co., have been given the contract to install the fire alarm system at \$718.78.

Montreal, Que.—Anglins, Ltd., has been awarded contract for a shipbuilding berth for the Canadian Vickers Co., Montreal.

Brantford, Ont.—The City Council have accepted the tender of the Watrous Engine Works for a boiler for the pumping station.

Port Arthur, Ont.—A provisional contract has been let by the Port Arthur Pulp & Paper Co., to the Wickes Boiler Co., Saginaw, Mich., for three 365 h.p. boilers.

Toronto, Ont.—The following contracts have been awarded by the York Township Council for the waterworks system. For 6-in. pipe National Iron Works, \$10.40 per length; 12-in. pipe, Canadian Allis-Chalmers, at \$26.75 per length; 1,150 lengths 24-in. pipe National

Iron Works, at \$84.35 per length; automatic air valves, Drummond-McCall Co., at \$16.50 each; special 24-in. cast iron pipe, National Iron Works, at total of \$702.05; 6-in. and 12-in. special castings, National Iron Works, \$220.85; valves, the Chapman Valve Co., at prices of \$410 and \$105 according to specifications. These prices were, according to the township engineer, F. Barber, all well within his previous estimates.

MARINE

Vancouver, B.C.—City Engineer Fellows has prepared a report on harbor development in which it is suggested that an area of False Creek be retained for factory sites.

Victoria, B.C.—The keel for the fourth auxiliary schooner was laid at the Cameron Genoa Mill Shipbuilders, Ltd., shipyard, on Feb. 6, on the ways occupied by the schooner Margaret Haney, which was launched recently.

Esquimalt, B.C.—Messrs. Yarrows, Ltd., have secured the contract for overhauling and repairing the American four-masted barkentine Puako, which arrived recently from Durban, South Africa, after a passage of 103 days.

Port Arthur, Ont.—Ice conditions at this end of Lake Superior favor an early opening of navigation. Open water commences at Thunder Cape, 18 miles out. The weather has been cold, but high winds have kept the ice broken up.

Esquimalt, B.C.—The municipal council has decided to memorialize the Provincial Government on the Esquimalt drydock question, recommending that pressure be brought to bear upon the Federal authorities to have the undertaking carried out without further delay.

Midland, Ont.—A movement has been started to have a dry dock established here. In the furtherance of the scheme a deputation has visited Ottawa and asked for assistance in the work of dredging in connection with the proposed dry dock and shipyard.

Chatham, Ont.—Engineers Porter and Griesbaek, of the Department of Public Works, Windsor, Ont., have commenced the work of making soundings in the River Thames from Chatham to the lighthouse. The report is being prepared in connection with the proposal to dredge a fourteen-foot channel from Chatham to Lake St. Clair.

North Vancouver, B.C.—The Wallace Shipyards have been awarded the contract for effecting the repairs to the G. T. P. steamer Prince John necessitated through the vessel's recent stranding in Wrangell Narrows. About 15 plates will have to be replaced and it is reported that slight injury to her engines and frames was sustained.

Cunard Line Places Orders in U. S.—Contracts for ships to cost over \$13,000,000 have been awarded the Harlan & Hollingsworth Corporation, of Wilmington, Delaware, by the Cunard Line and the United Fruit Co. It is the first time either concern has ever placed contracts with an American shipyard

"HAWK" D
CHROME
VANADIUM
STEEL



Will
 Give You
 Exceptional

Shell Forging Production

WITHOUT AN EQUAL FOR
 BOTH FIRST AND
 SECOND OPERATION
 PUNCHES.

Comes to you heat-treated
 and ready for use.

It does not stick to the
 work.

There are many cases where
 each punch has turned out
 over 2,000 shells.

It means more shells, per
 machine per day.

STEEL OF EVERY
 DESCRIPTION.

**Hawkrige Brothers
 Company**

303 Congress St., BOSTON, MASS.
 U. S. A.

The vessels for the Cunard Line are to be freighters of 15,000 tons capacity.

CATALOGUES

Power Hammers.—Bulletin describing the product of Beaudry & Co. Inc., Boston, Mass. The principal constructional features of the "Champion" and "Peerless" hammers are described at length and the claims in their favor set forth in detail. Among the illustrations are included views of the mechanisms, while tables give the principal dimensions and the other data for each of the various sizes of hammer.

Monometer Mfg. Co., Birmingham, England, have issued two bulletins dealing respectively with the "Monometer" metal melting furnace and automatic heat control. The former describes and illustrates the furnace, and also contains a number of testimonials from satisfied users in Great Britain and the United States. In the other bulletin, the "Monometer" self-acting heat regulator is described, and the work for which it is adapted, dealt with. A leaflet is included, giving the standard prices for the above in various sizes, and also for low pressure gas burners.

The Hydraulic Press Mfg. Co., Mount Gilead, Ohio.—Export Catalog No. 70, "Hydraulic Presses and Pumps". Size 8 in. x 10 in., 84 pages, describes and illustrates their line of hydraulic machinery adapted to foreign distribution. The first 7 pages are devoted to general data; pages 8 to 35, inclusive, to metal working presses; 36 to 40, inclusive, to veneer presses; 41 to 44 to baling presses; 47 to 48 abrasive wheel presses; 50 to 56, inclusive, leather presses, 57 to 67, inclusive, butchers and packers presses; 68, 69 and 70 to oil presses; 71 cider, wine & Grape juice presses; 72 and 73 hot plate presses; 76 hydraulic pumps. A copy will be sent to interested concerns.

BOOK REVIEWS

Mechanical World Pocket Diary and Year Book for 1917, 453 pages, 6 in. x 4 in. Norman Remington & Co., Baltimore, Md. Price 40 cents post free. The 30th annual issue of this year book, published by Emmot & Co., Manchester, contains several new features, while the book generally has been thoroughly revised. The section on steam and the steam engine has been rewritten. New tables have been introduced, giving dimensions of piston rings, governors, etc., while notes on lubrication and anti-friction bearings are now included. A new section on the heat treatment of steel has been introduced, including notes on annealing, hardening, tempering, etc. Other new matter includes tables, giving dimensions of flanged couplings and calculation of springs. Much recent information is also given regarding design of prime movers, boilers, power transmission, machine shop practice and materials. A 57-page diary and memoranda is a useful feature of this publication.

**Davis-Bournonville
Oxy-Acetylene Welding and Cutting Apparatus Leads the World**

Over 2,400 plants in daily operation. Medal of Honor, Highest Award at Panama Exposition.

- PORTABLE GENERATORS
- STATIONARY GENERATORS
- WELDING TORCHES
- CUTTING TORCHES
- REGULATORS
- HOSE
- CARBIDE
- WELDING RODS
- FLUX
- CARBONITE RODS
- GOGGLES
- CARBON REMOVERS
- PORTABLE TRUCKS
- COMPRESSED ACETYLENE

Price list and full particulars on request.

Carter Welding Co.

9-11 Sheppard Street

TORONTO, ONT.

Phone Adelaide 2841

Canadian Agents for

The Davis-Bournonville Apparatus

"PURO - FY"

(MADE IN CANADA)

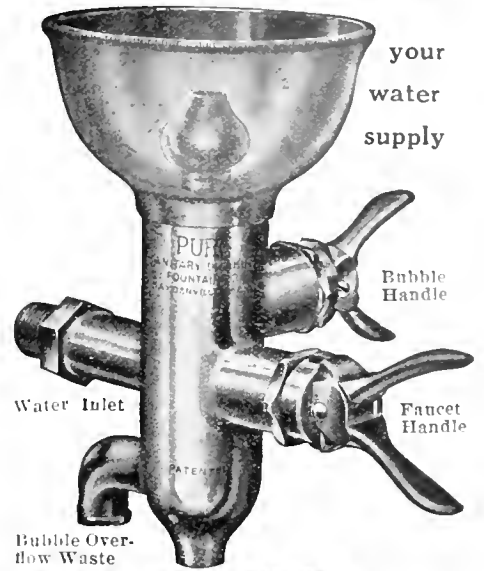

THE American Museum of Safety conferred a Gold Medal Award upon the Puro Sanitary Drinking Fountain at the First International Exposition of Safety and Sanitation. The Puro Sanitary Drinking Fountain won because it deserved to win—Puro had merits that made it stand head and shoulders above any other drinking apparatus.

Safe SANITARY Simple Economical Quickly Attached

These are the qualities that forced the leading safety and sanitary engineers to pick Puro in preference to all others. No device can be as efficient that does not contain all these qualifications; and Puro was not tied for first place; Puro was first. Don't be satisfied with half-way goodness, or makeshift drinking arrangements for your employees. If the men in your factory must drink, give them a clean drink. Puro is clean—it does not rust or corrode. Puro is economical. It allows just the proper amount of cool, clean, fresh water to come through the bubbler. No spurting, no overflowing, no loss. Puro regulates itself. You can attach it in five minutes. Tell us how many men in your factory and your water pressure in pounds.—We'll tell you just what it will cost to "PURO FY" YOUR WATER SUPPLY.

PURO SANITARY DRINKING FOUNTAIN

TRADE MARK

147 University Ave. TORONTO, ONT.

"Barnes-Made" SPRINGS

are unusual in service and wear

They are the result of sixty years' experience, unsurpassed equipment and highly skilled workmanship.

A trial will convince you that "Barnes-Made" Springs are the best buy.

Established 1857.

THE WALLACE BARNES COMPANY
218 South St., Bristol, Ct., U.S.A.

Makers of "Barnes-made" Products
Springs, Screws, Machine Products, Cold Rolled Steel and Wire

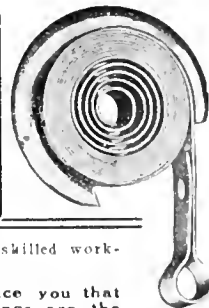

THE IRON WORKS LIMITED

Successors to

Owen Sound Iron Works

Owen Sound, Ont.

Engineers

Boiler-makers

Founders

Machinists

Tank Work
Smoke Stacks,
Grey Iron and
Brass Castings,

Special Machinery

Made to Order

Classified Advertising Section

Rates (payable in advance): Two cents per word first insertion; one cent per word subsequent insertions. Count five words when box number is required. Each figure counts as one word. Minimum order \$1.00. Display rates on application.

FOR SALE

FOR SALE—ENGINE LATHE 30" SWING, 8 ft. bed. Putnam make, good strong tool, cheap. Box 269, Canadian Machinery. (c8m)

FOR SALE—LOT OF WOODWORKING machinery — shafting, pulleys, hangers, belting, etc. Cheap. Box 270, Canadian Machinery. (c8m)

FOR SALE—TEN TONS 5/8" HIGH DUTY galvanized steel guy wire, made up of 7 strands of 3-16" wire—low price. Winnipeg Machinery Exchange, Sutherland St., Winnipeg, Man. (c8m)

GAP LATHE, 28 x 42 x 16 FT. BED, FOR sale, cheap; also emery wheel stand, power hack saw. Guarantee Motor Co., Hamilton, Ont. (tf)

FOR SALE—1 NEW SHORE SCLERO-scope, complete with all regular equipment. Pease Foundry Company, Limited, Brampton, Ont. Jct. 4341. (c6m)

SHRAPNEL SOCKET AND ADAPTER machinery, turret lathes, boring machines, cutting-off machines and thread millers tooled for operation. Globe Electric Machine Co., Hanilton. (tf)

FOR SALE—ONE 450 H.P. THOMPSON & Williams condensing engine. Will sell cheap. Engine is in first-class repair and will give every satisfaction. Apply J. A. Marven, Limited, Moncton, N.B. (tcfm)

1—2-SPINDLE SHAPER, WOOD TOP, JOHN Ballantyne, Preston, make, used two months. 1 Dynamo, 45 lights, Toronto and Hamilton Electric Co. make. Used five months. Good as new. Box 195, Jordon, Ont. (R.T.P.)

25 CYCLE MOTORS IN STOCK TORONTO. Sizes in horse-power tens, fifteens, twenties, thirties, forties, fifties, seventy-five and one hundred fifty, standard voltage, slow speed. Boyd-McBurney, 220 King St. West, Main, 2330. (c7m)

ONE LATHE 16" x 4 1/2' back geared. Built by P. P. Silk Machine & Tool Co., Cincinnati, Ohio. One lathe 18" x 3', back geared. Built by the Bradford Mill Co., Cincinnati, Ohio. Four Murehey Collapsible Dies. Capacity 1 1/2" to 2 1/2". Box 272, Canadian Machinery. (c7mf)

1 ONLY—10" WESTINGHOUSE LOCOMO-tive air compressor, first-class condition, all complete, ready for installation. 1 only, 6 x 6 Imperial type Canadian Ingersoll-Rand Company air compressor, in good condition, complete, ready for installation. H. Mueller Mfg. Co., Ltd., Sarnia, Ont. (c8m)

FOR SALE—2 KENNEDY CUTTING-OFF machines, for cutting off both ends of 4.5 H.E. forgings; in good condition; price \$750 each. 1 18-pdr. Holden-Morgan thread miller for threading base end of high explosive shells; price \$300. 1 18-pdr. H.E. marking machine; price \$50. Apply to Alton Foundry Co., Ltd., Alton, Ontario. (c13m)

WANTED

SHOP IN WINDSOR, ONT., EQUIPPED partially or wholly for special machine, tool and repair work. Send full details. F. G. Hubbard, Box 52, Bridgeport, Conn. (c9m)

WANTED—MOTORS 10 TO 50 HORSE-power, 25 cycle, 550 volts, alternating current. Quote price and delivery. Canadian Fairbanks-Morse Co., 1379 Bloor Street, Toronto. (c11m)

SPECIAL MACHINERY

FUSE EQUIPMENT—SPECIAL MACHIN-ery for manufacturing fuses, including rethreading machines for base plugs, with tools. "Harris," Box 1008, Bridgeport, Conn. (c9m)

MANUFACTURERS—WE CAN UNDER-take work to any specification—munition production equipment or otherwise. Write W. H. Sumbing Machinery Co., 7 St. Mary St., Toronto.

Machine Shop FOR SALE

Toronto, going concern, Universal milling machine and grinder, 4 machine lathes, 2 Fox lathes, shaper, drills, etc. Modern tools, A1 condition. Good lease; splendid central location.

Box 267 - Canadian Machinery

FOR SALE Shipment from Stock

3—"Lees Bradner"
Thread Millers
arranged for mill-
ing 2" 14 thread in
Nose of 4.5 Mark
VII H.E. Shells.

*For complete particu-
lars—write*

Williams & Wilson
Limited
320 St. James St., Montreal, P.Q.

SITUATIONS WANTED

SUPERINTENDENT OR GENERAL FORE-man, expert mechanic and mechanical engineer, experienced on 3", 6", 8" and 9" H.E. shells. Box 268, Canadian Machinery. (c9m)

SUPERINTENDENT OR WORKS MAN-ager desires position with first-class concern. Specialist on automatic small die press work. Expert in handling men. Twenty years' experience as manager in cartridge factories. Capable of taking complete charge of installation. Apply Box 263, Canadian Machinery. (7)

SITUATIONS VACANT

DRAFTSMAN WANTED ON MACHINE shop equipment—jigs, tools, etc. State experience and salary expected. Box 265 Canadian Machinery. (9)

CANADIAN REPRESENTATIVE FOR American firms building special machinery, tools and gauges. Liberal commission to a business-getter. Box 266, Canadian Machinery. (c9m)

DIE MAKERS—SERVICES OF TWO FIRST-class die makers to work on small dies for parts of electrical wiring devices. Apply Toronto Electrical Supply Work, King street Subway. (c10m)

FOREMAN WANTED—FOR TURNING, milling and threading department of a manufacturer of taps, dies, milling cutters and other lines of small tools. Steady employment, with opportunity of advancement. Apply, stating wages expected and former experience. Young married man preferred who will permanently settle in Canada. Box 275, Canadian Machinery. (c11m)

What have you to sell?

Have you old or used machinery or any equipment for which you have no further use, or are your services for sale?

If your proposition will interest the men or the firms we reach, the logical place for it to appear is in these columns.

Canadian Machinery

Classified Advertising Section
143 University Ave., Toronto, Ont.

CANADIAN MACHINERY

AND MANUFACTURING NEWS

A weekly newspaper devoted to the machinery and manufacturing interests.

Vol. XVII.

TORONTO, MARCH 1, 1917

No. 9

EDITORIAL CONTENTS

Machining the 4.5 ins. Mark VII. Howitzer Shell	169-173
Notes on Export Practice	173-174
General	174
Electric Light and Power at Edmonton, Alta.	
Production Methods and Devices	175-178
Solving a Mechanical Problem....Simple Multiple Clamps....Drilling Bases of 4.5 in. H. E. Shells.	
General	178
South African Trade Notes....Cyanide in Canada.	
Spokes in Industry's Wheel	179
Karl E. Barrett.	
Editorial Correspondence	180-181
Mechanics' Instruction Course—XIV....Impromptu Shell Boring Machine.	
General	181
French Supplies of Reconstruction Materials....Russia Buying in Canada....Canada's Trade Increases Rapidly.	
Safe Practice at Blast Furnaces and Its Development—V	182-185
General	185
Mineral Resources of British Empire.	
Progress in New Equipment	186-188
Gear Drive Pipe Threading Machine....Electric Riveter for Shell Base Plates Special Duplex Milling Machine....Square Hole Drilling Device.	
General	188
To Develop Resources of the Dominion.	
Editorial	189
Last Month's Happenings—This Month's Sacrifice and Service.	
Selected Market Quotations	190-191
The General Market Condition and Tendency	191-194
Summary....Montreal Letter....Toronto Letter Barred From Import by BritainToronto Harbor Development Programme.	
Industrial and Construction News (Advtg. Section)	62

THE MACLEAN PUBLISHING COMPANY, LIMITED

JOHN BAYNE MACLEAN, Pres. H. T. HUNTER, Vice-pres. H. V. TYRRELL, Gen. Man.

Publishers of Hardware and Metal, The Financial Post, MacLean's Magazine, Farmer's Magazine, Canadian Grocer, Dry Goods Review, Men's Wear Review, Printer and Publisher, Bookseller and Stationer, Canadian Machinery and Manufacturing News, The Power House, The Sanitary Engineer, Canadian Foundryman, Marine Engineering of Canada.

Cable Address: Macpubco, Toronto; Atabek, London, Eng

ESTABLISHED 1887.

CANADIAN MACHINERY AND MANUFACTURING NEWS

PETER BAIN, M.E., Editor. B. G. NEWTON, Manager.
Associate Editors: A. G. WEBSTER, J. M. WILSON, J. H. RODGERS

CHIEF OFFICES:

CANADA—Montreal, 701-702 Eastern Townships Building; Toronto, 113-113 University Ave., Telephone Main 7324; Winnipeg, 22 Royal Bank Building, Telephone Garry 2313.

GREAT BRITAIN—LONDON, The MacLean Company of Great Britain, Limited, 88 Fleet Street, E.C., E. J. Dodd, Director. Telephone Central 12300. Cable Address: Atabek, London, England.

UNITED STATES—New York, R. B. Hewitt, 115 Broadway, N.Y., Telephone Rector 9751; Boston, C. L. Morton, Room, 733, Old South Building, Telephone Main 1204. A. H. Byrne, 11015-167 Port Dearborn Bldg., 105 W. Monroe St., Chicago, Telephone Randolph 3231.

SUBSCRIPTION PRICE—Canada, Great Britain, South Africa and the West Indies, \$3.00 a year; United States, \$3.50 a year; other countries, \$4.00 a year; Single Copies 15 cents. Invariably in advance.

Hendey Experimental 12" Lathe

For the Laboratory or Experimental Department where the best of its kind is wanted, and each machine must be motor-driven, here is the Lathe in this HENDEY 12".

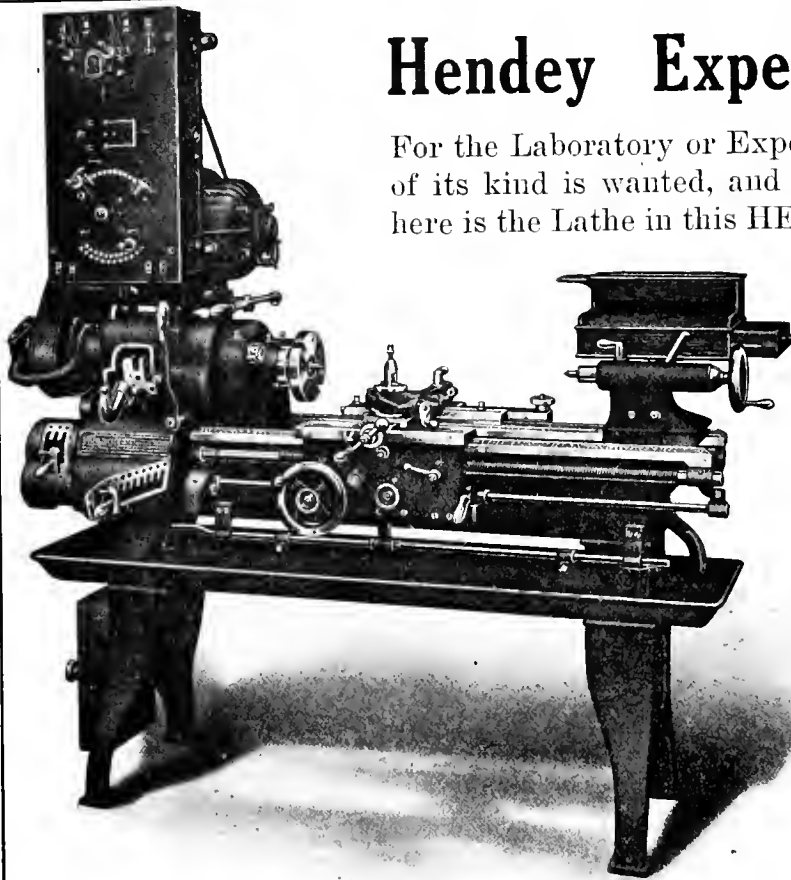

In addition to its complete regular equipment it has Small Tool Cabinet for operators' fine tools, also gear closet for extra gears to cut special threads.

Write for Descriptive Matter.

The Hendey Machine Co.

Torrington, Conn., U.S.A.

Canadian Agents: A. R. Williams Machinery Co., Toronto, Ont.; A. R. Williams Machinery Co., 260 Princess St., Winnipeg; A. R. Williams Machinery Co., Vancouver; A. R. Williams Machinery Co., St. John, N.B.; Williams & Wilson, Montreal.

INDEX TO ADVERTISERS

Aeroplane Products, Ltd.	119
Albany Pump Co.	70
Anderson, H. N.	98
Armstrong Bros. Tool Co.	118
Armstrong, Whitworth, of Canada	12
Atkins & Co., Wm.	13
Atlas Crucible Steel Co.	12
Atlas Press Co.	117
B.A.B. Model Mfg. Co.	89
Babeock & Sons	70
Baird Machine Co.	119
Banfield, E. J.	71
Banfield & Sons, W. H.	68
Bames, Wallace, Co.	68
Baxter & Co., J. R.	15
Bertram, John, & Sons Co.	1
Belevue Industrial Furnace Co.	106
Blackall, Fred S.	84
Blake Pump & Condenser Co.	91
Blake & Johnson Co., The	147
Blount Co., J. G.	15
Brantford Oven & Rack Co.	5
Bridgford Mach. Tool Works	5
Bristol Co.	116
Brownell Machy. Co.	76
Brown-Hoggs Co.	Front cover
Brown's Copper & Brass Rolling Mills	91
Buddeo, Handbury A.	70
Canada Machinery Corp.	Outside back cover
Canada Metal Co.	95
Canada Sales Co.	56
Can. Bond Hanger & Coupling Co.	100
Can. Desmond-Stephan Mfg. Co.	88
Can. Economic Lubricant Co.	103
Can. Fairbanks-Morse Co.	34
Can. Ingersoll-Rand	133
Can. Inspection & Testing Laboratories, Ltd.	114
Can. SKF Co.	4
Can. Matthews Gravity Co.	69
Can. Metal Products Co.	117
Can. Morehead Mfg. Co.	82
Can. R. K. Norton Co.	6
Can. Steel Foundries, Ltd.	7
Carborundum Co.	117
Carlyle, Johnson Mach. Co.	99
Carter Welding Co.	64
Chapman Double Ball-Bearing Co.	100
Cincinnati Iron & Steel Co.	30
Cincinnati Lubricant Pump Co.	65
Cincinnati Pulley Mach. Co.	68
Cleveland Milling Mach. Co.	59
Cleveland Pneumatic Tool Co.	123
Cleveland Twist Drill Co.	103
Clipper Belt Lacer Co.	118
Cook, Asa S., Co.	118
Corbet Fdry. & Mach. Co.	18
Cullen Mch. Co., C. E.	75
Cummings & Son, Ltd., J. W.	82

Curtis Pneumatic Mch. Co.	102
Cushman Chuck Co.	116
Davis-Roumonville Co.	119
Davis & Co., J. A.	107
Davis, W. F., Machine Tool Co.	77
Deloro Smelting & Refining Co.	14
De Mooy Mach. Co.	81
Dept. of Finance	120
Detroit Pneumatic Chuck Co.	115
Diamond Saw & Stpg. Works	82
Dillon Mfg. Co.	108
Dominion Mch. Co.	74
Dominion Steel Fdry. Co.	73, 117
Drury, H. A., Co.	7
Elmes Eng. Works, Charles F.	105
Erie Foundry Co.	86
Fairley-Davison Steel Co.	11
Fetherstonhaugh & Co.	70
Fitzgerald, W. H. J.	75
Foss & Hill Machy. Co.	Inside back cover
Foundry & Mach. Co.	89
Francis & Co.	117
Gardner Machine Co.	129
Garlock-Walker Machy. Co.	50
Garvin Machine Co.	92
General Supply Co.	73
Geometric Tool Co.	61
Gibb Instrument Co.	97
Grant Gear Works, Inc.	119
Grant Mfg. & Machine Co.	123
Graton & Knight Mfg. Co.	105
Hamilton Gear & Machine Co.	14
Hamilton Mach. Tool Co.	25
Hamilton Motor Works, Ltd.	117
Hanna & Co., M. A.	9
Harding Bros.	91
Hawkeville Brothers Co.	68
Hendey Machine Co.	138
Hepburn, John T., Ltd.	23
High Speed Hammer Co.	123
Himoff Mach. Co.	119
Hollander Machy. Co.	73
Holz, Herman A.	147
Hovt Metal Co.	120
Hull Iron & Steel Foundries	125
Hungerford Brass & Copper Co., U. T.	106
Harbit-Rogers Machy. Co.	117
Hyda Engineering Works	116
Ideal Tool & Mfg. Co.	114
Illinois Tool Works	63
Independent Pneumatic Tool Co.	123
Iron Works, The	67
Jacobs Mfg. Co.	110
Jenckes Machine Co.	9
Jersey City Machine Co.	117
Jones & Glasco	103
Johnson Mach. Co., Carlisle	99

Kasent, Ltd.	15
Kennedy, Wm., & Sons	92
King, Lbl., Warden	18
Kilston & Co., A. G.	53
L'Air Liquide Society	120
Lancashire Dynamo Co.	86
Lanús Machine Co.	119
LeBlond Mach. Co., R. K.	11
Lyman Tube & Supply Co., Ltd.	101
MacKinnon, Holmes & Co.	71
Main Belting Co.	114
Manufacturers Equipment Co.	94
Marsh & Henthorn	118
Matthews, Jas. H., & Co.	24
McCabe, J. J.	15
McCoy-Brandt Machy. Co.	Inside back cover
Mcdougall Co., R.	94
McKay Co., James	118
Mechanical Engineering Co.	19
Metals Coating Co.	15
Metalwood Mfg. Co.	97
Millholland Mach. Co.	91
Miller-Smythe Electric Co.	75
Millers Falls Co.	89
Molten Machy. Exchange	73
Modern Tool Co.	111
Monarch Brass Mfg. Co.	88
Montreal Machy. & Supplies, Ltd.	81
Montreal General Tool Co.	123
Morse Twist Drill Co.	69
Morton Mfg. Co.	112
Murphy Machine & Tool Co.	112
National Electric Welder Co.	90
National Machine Tool Co.	120
New York Machy. Exchange	74
Nicholson File Co.	96
Niles-Bement-Pond	Inside front cover
Noble & Westbrook	113
Northern Crane Works	102
Norton, A. O.	112
Norton Company	32
Nova Scotia Steel & Coal	8
Oliver Machinery Co.	28
Ontario Specialties, Limited	119
Oven Equipment & Mfg. Co.	108
Parmenter & Bulloch Co.	116
Peerless Mach. Co.	81
Perrin, Wm. R.	96
Petrie, H. W.	73
Positive Clutch & Pulley Works	119
Pratt & Whitney Co.	Inside front cover
Price Electric Co.	71
Pringle, R. E. T.	31
Puro Sanitary Drinking Fountain Co.	67
Racine Tool & Machine Co.	61
Reed-Prentice Co.	33

Reliance Machine Co.	27
Rivett Lathe & Grinder Co.	136
Rickert-Shafer Co.	87
Ridout & Maybee	70
Riverside Mach. Co.	75
Rhodes Mfg. Co.	30
Rockwell Co., W. S.	118
Rodofson Mach. & Tool Co.	19
Roper, C. F., Co.	104
Root & Vandervoort Engr. Co.	21
See Elect. Elevator Co.	74
Scott Mach. Co., G. H.	88
Shuster Co., F. B.	117
Sidney Tool Co.	24
Silberberg, Mortimer J.	81
Simmons Mach. Co.	76 and 127
Skinner Chuck Co.	97
Slocum, Avram & Slocum	116
Smalley-General Co., Inc.	85
Standard Alloys Steel Co.	83
Starrett Co., L. S.	71
Stetzer Co., Chas.	119
Smart-Turner Mach. Co.	76
Smith Mach. Co., H. A.	69
St. Clair Bros.	83
Steel Breading Brake Works, Ltd., The	118
Steel Co. of Canada	3
Steppe Co., John	98
Stocker-Rumley-Vachs Co.	77
Stone Tool & Supply Co., J. R.	88
Stow Mfg. Co.	131
Swedish Steel & Importing Co.	9
Tabor Mfg. Co.	118
Taylor Instrument Co.	69
T. C. M. Mfg. Co.	28
Thomas Elevator Co.	113
Thwing Instrument Co.	107
Toronto Iron Works	116
Toronto Testing Laboratory	119
Toronto Type Foundry	99
United States Electrical Tool Co.	133
Vanadium-Alloy Steel Co.	17
Vulcan Steel Products	16
Walcott Lathe Co.	26
Warner & Swasey Co.	77
Wellhome & Co.	64
Wells Bros. of Canada, Ltd.	32
Whiting Foundry Equipment Co.	104
Whitman & Barnes Mfg. Co.	87
Whitney Mfg. Co.	109
Wickes Brothers	20
Williams, J. H., & Co.	97
Williams Machy. Co., A. R.	7 and 69
Windsor Mach. & Tool Works	116
Winnipeg Gear & Engr. Co.	135
Wisconsin Electric Co.	135
Wright Mfg. Co.	79
Zenith Coal & Steel Products	119
Zin-Ho Mfg. Co.	131

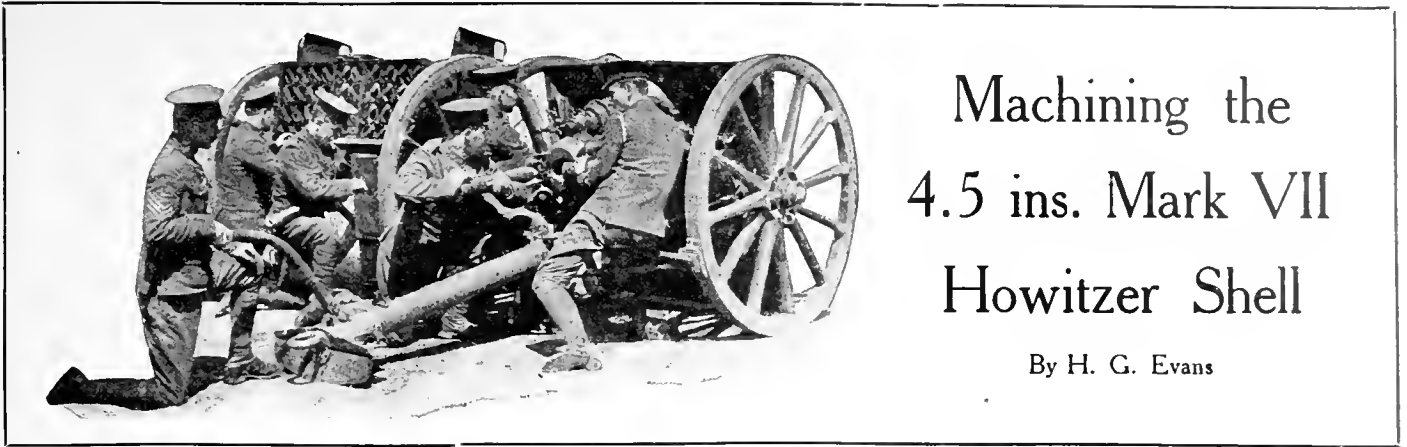

Machining the 4.5 ins. Mark VII Howitzer Shell

By H. G. Evans

In our January 11, 1917 issue, there appeared an illustrated descriptive article covering the "Machining of the 4.5 ins., Mark VII, Howitzer Shell," the data for which had its origination in a plant close to the extreme Western limit of our far-flung Dominion. The reference then made to the width of scope of munitions manufacture within our borders receives the necessary substantiation in the case of the present article, the constituent detail of which typifies production of the same type shell in a plant whose location is well nigh to our extreme Eastern boundary, or, in other words, is operative on our Atlantic seaboard.

THE new 4.5 in. Mark VII. howitzer shell being such a radical departure from the old Mark V., presents many little points of difference in the method of manufacture which add to the difficulties of successful production. Just at this period, when so many firms are changing over to this type, it may be interesting to study some of the methods employed relative alike to quality and quantity output. The plant from which the following data was procured has been working on this class of shell for several months, and an output of about 500 shells per day is now being maintained. Two years ago, when the shell-making industry was in an incipient state, and the outlook appeared to be one of short but abnormal activity, this firm, when purchasing machinery to augment their existing equipment, did so with a view to utilizing it more for future trade than for conditions as they appeared at that time. This firm, how-

more economical production of all classes of shells. Nevertheless, much credit is due to those manufacturers who have successfully solved the problem by the use of special fixtures alone, adapting these to available machines with very satisfactory results. Next to special equipment, the one factor that tends to higher efficiency is the machine tool layout, which should be so designed as to minimize the handling of the shells as they progress through the shop. While this shop may not be ideal, a glance at the plan, Fig. 1. will give some conception of the continuous movement of the shells from the rough forging to the finished product.

Mark V. Production Less Onerous

After adjusting the sizes of shell on the roughing operations to take care of the change in weight and length from the former standards set up for the Mark V., the chief difficulty is encoun-

often a risky and unsatisfactory method. Owing to the greater depth of nose metal required on this type, it is necessary to have the outside diameter at the mouth sufficiently large for the purpose; and

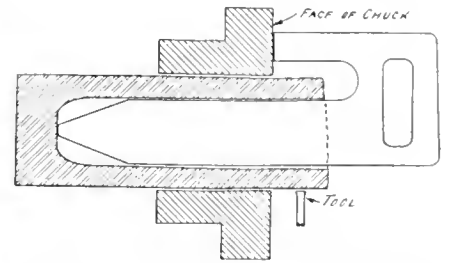

FIG. 2. APPLICATION OF CUTTING-OFF GAUGE.

due to eccentricity of many of the forgings, much difficulty is often experienced in obtaining good results when nosing. For satisfactory work, the diameter for about $2\frac{3}{8}$ inches back from the open end should be at least 4 13-16 inches, and slightly larger would prove even more effective; however, owing to the varying characteristics of the forgings, many shells will not clean up to a greater diameter. It has been found that a proper nosing process is a very essential factor, and considerable care is exercised in all preliminary operations to insure accurate work on the press operation. Every facility is provided to have the ends cut off square with the axis of the shell.

The plant is operating 22 hours per day on two shifts; the latter alternating every week with satisfaction to the firm and appreciation by the workmen. The routine of the work is divided into three departments—roughing, nosing and finishing, each department having its own night and day foreman. The washing, varnishing, etc., are under the supervision of the press foreman. The assistant superintendent has full charge of the mobilization of shells through the

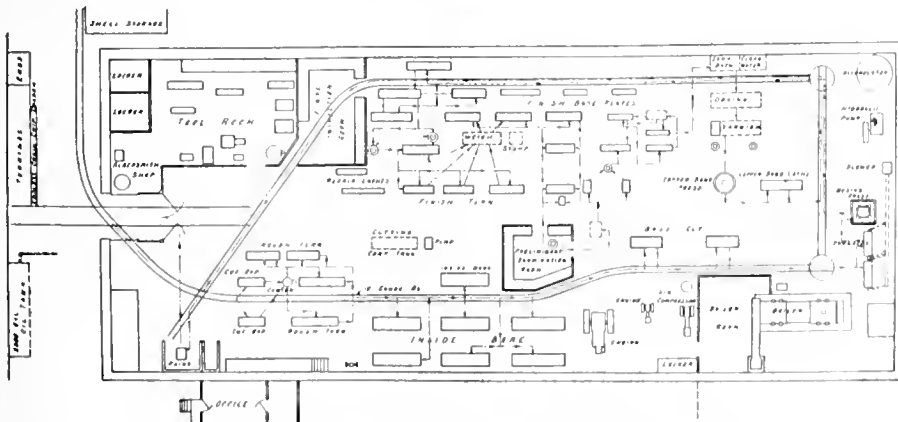

FIG. 1. MACHINE LAYOUT OF 4.5 INS. SHELL SHOP.

ever, in common with many others with a similar lack of forethought, are now looking with a certain degree of envy upon the numerous special machines that have been placed on the market for the

tered in securing sufficient stock on the inside of the shell nose to form the shoulder below the underent. It is the practice of some shell-makers to upset the shell under the press, but this is

shop, seeing that heat numbers are correctly transferred, keeping the machines supplied with shells, and otherwise exercising every vigilance in expediting their progress through the shop. The watchword of this plant is "Rigid In-

bottom of shell being cleaned up without cutting shell back, and thus shortening the enlarged nose.

After the base is centered, which is performed on a 20-inch Barnes drill, fitted with expanding arbor and suitable jig, the heat numbers are transferred to the base by means of an ordinary cold chisel, this method proving as satisfactory as the use of a steel stamp. The shells are next examined for concentricity, and should the variation of wall thickness be such as to prevent outside cleaning up to 4.9-16 in. diameter, they are chucked in a rigid Conradson lathe, where the eccentricity is partly adjusted by boring with a single point tool.

The rough turning operation is accomplished on several old engine lathes; one of these, a Gould & Eberhardt, shown in Fig. 3, was headed off on its way to the scrap pile, rebuilt and pressed into service. The headstock was designed to suit the new requirements, pulleys being placed on the back gear shaft, a 5-inch double leather belt providing sufficient power to drive through the heaviest cuts. Increased elasticity has been given to the feeding mechanism by substituting a 1 1/2-inch belt for the gears previously used. The use of the feed belt minimizes the breakage of tools and gears when unskilled workers carelessly allow the cut to run to a shoulder on the work. The usual hand feed was discarded and replaced by a large wheel with pinion meshing directly with the

are similar to those on other shells; that is, rough bore, rough base, finish bore, finish bore, cut to length, and chamfer. The finished bore is 3.38 inches, with a tolerance either way of .003 inch; the chamfer has a depth of 1 3/4 inches, and a large diameter of 4 1/8 inches. Chamfering the outer edge was tried, but the present method has given better satisfaction, as the shape after nosing conforms more to desired requirements. The length from the inner base to the open end is 12 1/4 inches plus or minus 1/64 inch.

Contrary to general practice, this firm does not remove any stock from the outside base until after boring. This not only eliminates previous base facing, but permits inside base being further machined, should defects appear, without materially affecting the thickness of metal. When doing this operation, it has been found advisable to fit the machines with a special arbor to avoid any possibility of sag when gripping the shell. This arbor, which is secured to a sleeve held in the body of the chuck, is provided with an adjustable stop that gauges the depth to which the shell is placed in the chuck. It is essential to have the base square with the axis of the shell, as it insures its standing perfectly upright in the nosing press. The thick-

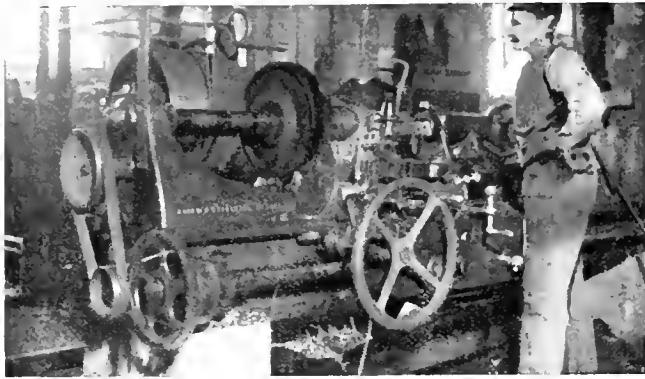

FIG. 3. ROUGH TURNING ON "GOULD & EBERHARDT" MACHINE.

spection," and its success, in a great measure, is due to the strict observance of specifications and careful gauging methods.

Fig. 1 is a layout of the shop and general arrangement of machines, from which it will be noted that shells follow a straight course up the right-hand side from A to B, thence from B to C. From C they are transported on trolley cars to D, whence they are started along the finishing side of shop to the preliminary inspection room E. From E to F they pass through all the final finishing operations, such as plugging, base facing, varnishing, banding and band turning. They are then placed in boxes and hauled to the final Government inspection room G, and from there to painting department H, where they are prepared for shipment and loaded in cars at I, being practically the point from which they started.

Cutting-off Open End and Centering Base

Two Davis cutting-off machines are used for cutting off the open end, the length measured from the inside being 12 1-16 inches. Fig. 2 illustrates the method of gauging. Care is exercised in cutting to exact length given, which is 3-16 inch shorter than the finished bore

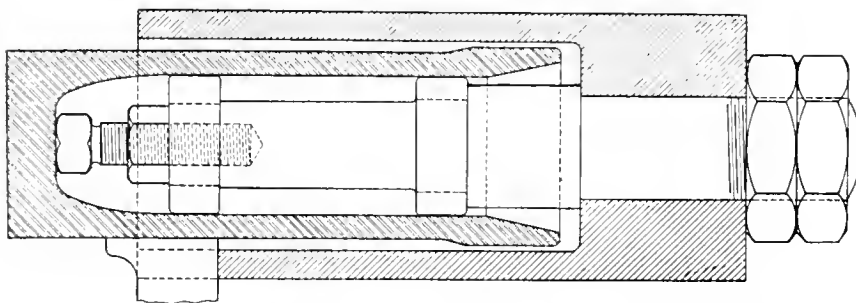

FIG. 4. SPECIAL CHUCKING DEVICE FOR "HALL" CUTTING-OFF MACHINE.

of shell, leaving that amount for the spade tools to remove. This is to keep the length of the large diameter of 4.13 16 inches constant, and permit of

feed rack. These machines have an average output of about 10 shells per hour.

The sequence of operations on the bore

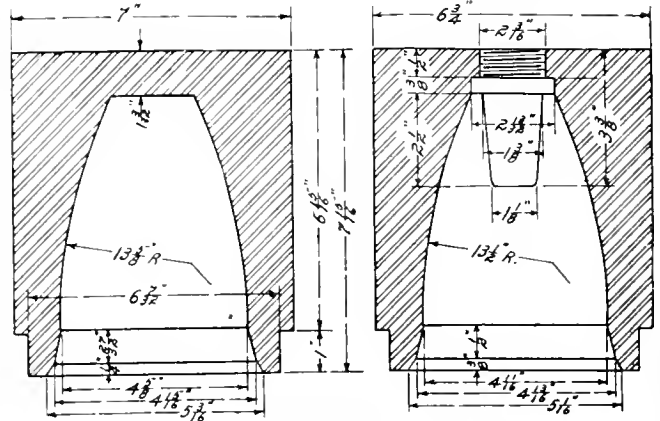

FIG. 5. NOSING DIES.

ness of metal at the base after facing should be 1 7/32 inches, with an over-all length of 13 15/32 inches.

The Nosing Operation

The link that unites the roughing and finishing departments, that of closing in the nose, is probably the most important factor in the manufacture of this shell, as the success of subsequent machining depends largely upon the accuracy of the nosing process, which is more difficult of attainment on the Mark VII. than on the Mark V. Two five-hole oil-fired Mechanical Engineering Co. furnaces, fed by a Trehearn rotary pump, are installed. Oil is delivered at a pressure of 25 lbs. and sprayed through nozzles into the fire chamber by means of high pressure air at 80 to 100 lbs. per square inch. Air for combustion is supplied at a pressure of 4 ounces. The shells are heated to almost white heat as far down as the bevel on the outside, and to insure an even distribution of heat the shells are turned at intervals, this precaution being

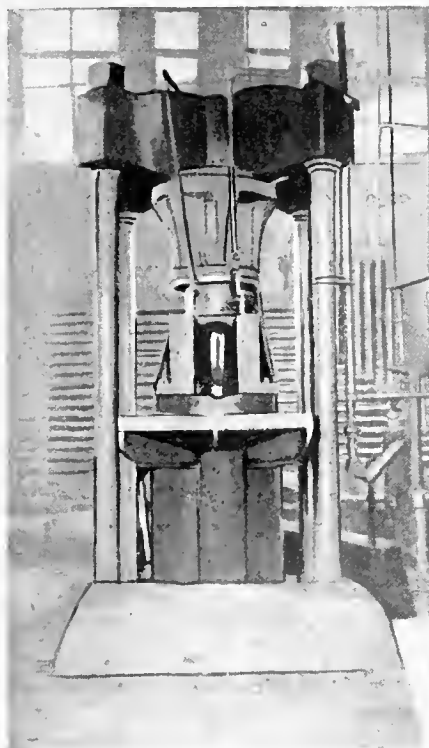

FIG. 6. NOSING OPERATION.

necessary, as unevenly heated shells are often the source of defective nosing. The alignment of the press should be periodically examined, as highly accurate work is only possible under the best working conditions.

The standard nosing is shown to the left of Fig. 5, but where the shells will not clean up to 4 13 16 inches diameter, it is necessary to upset in such a way that metal will be forced down to allow of sufficient thickness below the recess.



FIG. 7. AEROPLANE VIEW OF NOSE OPERATIONS

The die for this purpose is shown to the right. When using this die, shells are heated and nosed part way, and after a time are reheated about three inches down to a good white heat, and then forced right up to the top of the die and around the pin, which upsets shell slightly and forces metal down where required below the undercut. Fair success has been achieved by this method, but shells are very liable to bulge below the die unless carefully handled; besides, it is a slow and expensive method, doubling as it does the time and cost of nosing. After nosing, shells are placed in sheet iron boxes filled with air-slacked lime to anneal. Each box holds about 75 shells, and press foreman selects five shells from each box and has them finished as quickly as they can be cooled, to keep check on nosing operations.

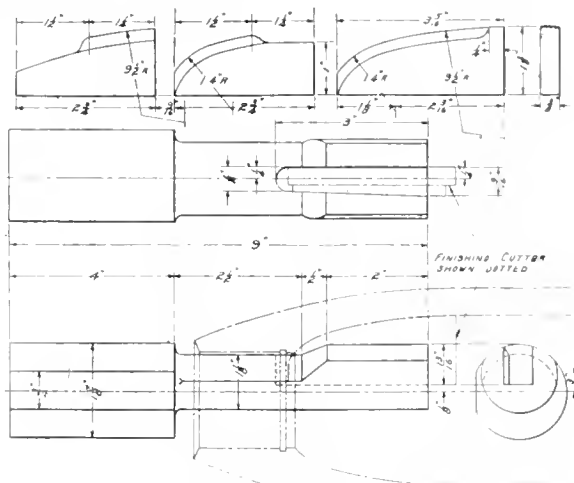
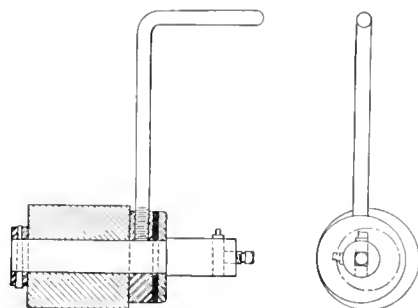

FIG. 5. TOOLS AND BAR FOR INSIDE NOSE PROFILE

Owing to the increased difficulties of nose operations and the greater degree of accuracy required, cross feeds were eliminated on the thread nosing operation, and the inside nose profile was finished on a separate machine. As the portion to be machined is often very uneven, three tools, shown in Fig. 8, are used, two roughing at different points and the third finishing the complete contour. Turret machines are used, each having a capacity of about 23 shells per hour. Hand sizing is necessary. The container seat hole is reamed by using reamers made from disarded taps.



7A. NOSE RECESSING TOOL.

Fig. 6 is a view of the press, and attention is drawn to telescoping die-holder and guide.

Nose Machining

An aeroplane view of nose machining is shown in Fig. 7, the sequence of operations being: rough bore, bore, counter-bore and face, ream two diameters and bevel face, undercut, and tap. The recessing tool as shown in Fig 7A, this being a small bar operating in a hole which is eccentric to the bush held in the turret. Before the shells are removed from the lathe, they are inspected for thread diameter, perfection of thread and depth of undercut. By using a pair of inside calipers from the thread diameter to the opposite edge of the nose profile, the inspector can tell whether there is sufficient metal to clean up, and, if not, the nose is cut back another 1/16

Finish Turning

Three Cincinnati pulley lathes are provided for the finish-turning operation. These machines are of standard pattern, fitted with two carriages. Rex AA high-speed steel is used, feed being 21 turns to the inch; an average production of 12 per hour is maintained. A special bevel horseshoe gauge is used to gauge the nose of the shell before removing from

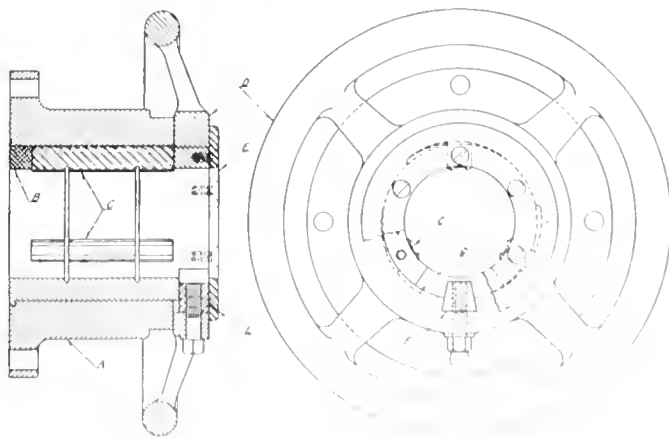

FIG. 8. COMPRESSION CHUCK.

the lathe. In addition to the routine examinations at each operation, all shells are given a general inspection after the

finish turn, following which they are weighed and marked for cutting to proper weight. From closely figured calculations, a chart has been devised showing the exact amount (in 64ths) to be

removed from the base to bring the shell to the desired weight of 27 lbs. 3 ozs. As a guide to the machine operator, the weigher places a pop mark on the shell for cut-off position, and also one .72-inch

these points being located by the locking bolt F operated by the handle G. The chuck is turned to its various positions by means of the hand wheel H. To prevent the cuttings from falling into the

nearer the nose to indicate the lower edge of the copper band groove. After the heat numbers are transferred and recorded, the groove for the band is cut in. One Reed and one Bertram machine are employed on this operation. Both these lathes are fitted with a special four-tool attachment, as shown in Fig. 9. The first tool is for roughing out to width, the second roughs out for the ribs, the fourth is for waving, and the third for undercutting. This arrangement is necessary owing to the fact that the tool for waving must be placed farthest from the generating cam, which is secured to the chuck or face-plate of the lathe.

Fig. 10 shows one of the base recessing machines (Garvin) in operation, the chamber being completed in one machine. The depth is gauged from the edge of the rifling band groove, and it is important that the surface be perfectly flat when tested with a scale.

Cutting Nose Slots

After gauging and removing burrs, three slots are cut in the nose. A special fixture has been designed for this purpose and is shown in Figs. 11 and 12. The entire arrangement is supported upon a concrete base, the piece A that holds the inclined fixture being secured to the upper portion of a heavy cross slide. The chuck B is made in two parts, the section C swinging on a large pin with clamp bolts opposite. When the shell is placed in the chuck, it

rests upon a short spring that forces it against the height gauge D. Plate E retains the base of the shell on its seat, but leaves it free to revolve to its several positions,

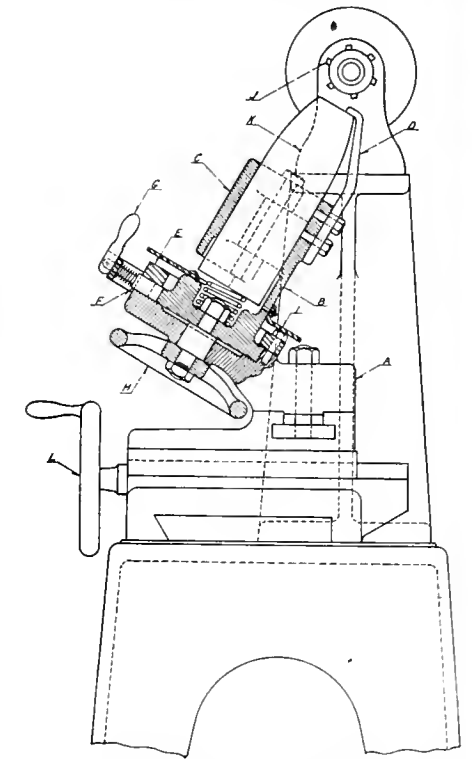

FIG. 12. SECTIONAL ELEVATION OF NOSE SLOTTING MACHINE.

turret, a thin plate I is secured to the chuck. The fixture, with the shell, is moved beneath the cutter J by operating the cross slide handle L.

The special cutter designed for use on the nose slotter is shown in Fig. 13, and, while quite simple, is very efficient. It consists of an arbor A carrying the supporting sleeve B, upon which the tools bottom, these latter being held in the slotted collar C. The two nuts D provide means of adjusting cutter to the centre line of fixture. This slotting arrangement is capable of producing three shells per minute.

Following the preliminary Government inspection, the base plates are put

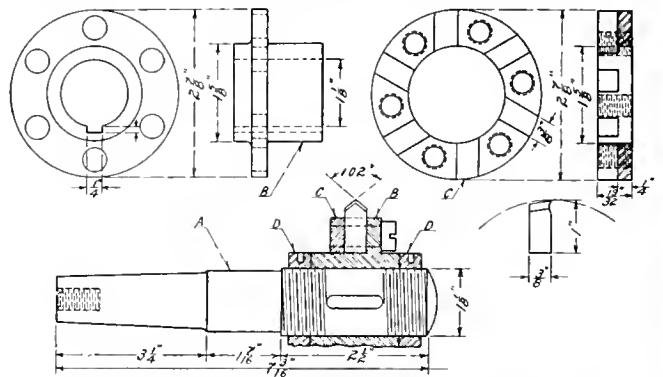

FIG. 13. MILLING CUTTER FOR NOSE SLOTTING MACHINE.

in. While a good fit is required, no forcing or hammering is permitted for fear of the plate not seating on the base of shell. The method adopted for testing

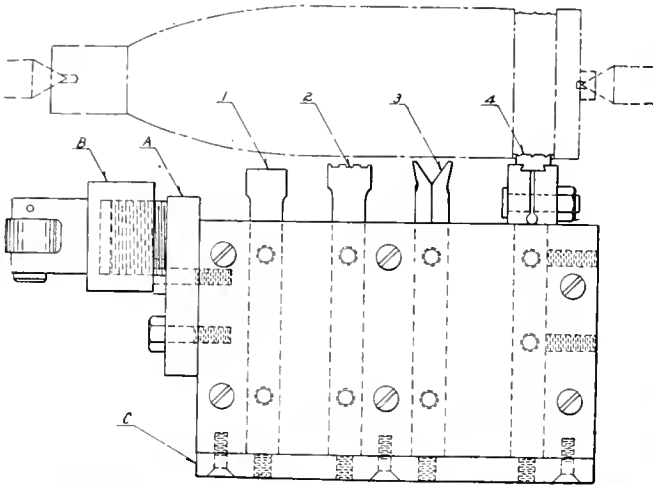

FIG. 9. TOOL ARRANGEMENT FOR GROOVE AND WAVE.

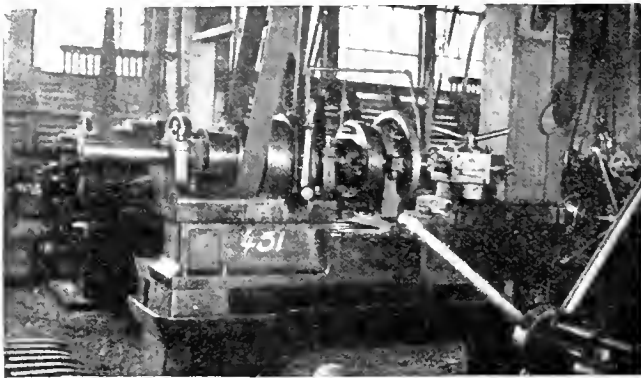

FIG. 10. BORING BASE ON "GARVIN" TURRET.

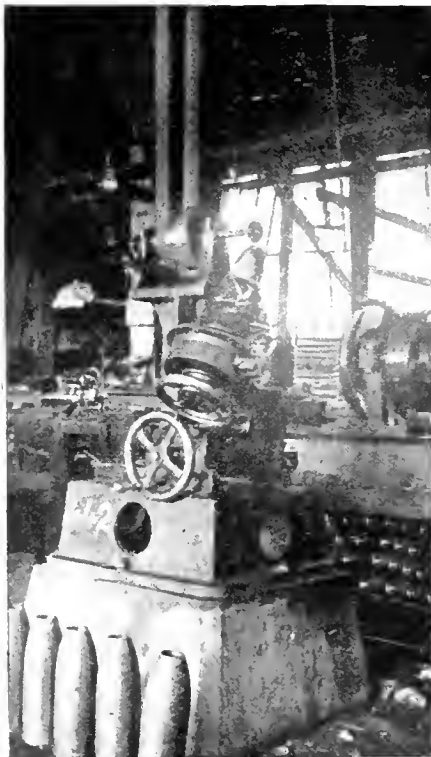

FIG. 11. NOSE SLOTTING MACHINE.

plates after riveting is by means of a bent pin placed on the base and tapping same with a light hammer, when a loose plate is easily detected. After the square is twisted off and the base faced, the shells are tested for dimensions and weight. The weight at this point, minus the copper band, which is reckoned at 11½ ounces, should be between 26 lbs. 12½ ozs. and 26 lbs. 6½ ozs., but to maintain a safe factor the shop inspec-

tion is painted in the "machine" shown in Fig. 15. This device is not patented, but is giving good satisfaction.

NOTES ON EXPORT PRATICE
By Commerce

TO shippers who are only occasionally concerned with the export of goods, the fact that a ton is not always a ton is somewhat confusing. A ship of a definite net register tonnage may be chartered, a cargo of a certain gross weight in tons shipped on her, or freight paid at the rate of \$30 per ton, yet in every one of the three cases the ton referred to is quite a different thing. Consider first the "freight" ton. In the earlier days of merchant shipping this really had reference to a ton of

navigation, it is desirable to keep this percentage as high as possible.

In the case of passenger liners, the ratio of nett to gross is very small, whilst, in one of our typical grain or ore freighters for Lakes service, the nett tonnage will be considerably more than 70 per cent. of the gross. Nett tonnage is the basis of all marine statistics, port and harbour dues, and is the chief factor in the chartering of a vessel for cargo. It will be seen that to ship a 10,000 ton cargo a 4,000 ton freighter will give the required capacity. An exception to this occurs where the cargo weighs more than 2240 lbs. per 40 cubic feet, in which case, perhaps, not more than 25 per cent. in excess of the registered tonnage could be carried. With heavy cargoes, the maximum would depend upon the season, as it would take a greater displacement to sink a vessel to her marks in summer than in winter particularly on the North Atlantic.

Cable Codes

In any office transacting a considerable amount of export business, a great deal of time and money can be saved by a really intelligent use of the cable codes. In addition to the use of the Western Union and other standard codes for the abbreviation of telegraphic messages, it is always desirable for a firm to have a private cipher for cabling their confidential agents and correspondents at foreign points. Such a code will have the great advantage of secrecy: that is it cannot be decoded without the use of the private key. It will also be economical because it can be devised on a five letter system thus enabling any two words to be connected and transmitted as a standard ten letter word. Lastly, the interpretation will have particular reference to the firm's own special products, classes of machinery, etc., which a commercial code cannot have. Let us devise such an arbitrary code as the above-mentioned, remembering that three rules must be followed, viz.

(a)—Every word used must be pronounceable (this is a stipulation of the Cable Company to assist their operators in securing accuracy).

(b)—Every word must consist of five letters, and, (c), each word must differ from every other by at least two letters. This last precaution ensures that the mutilation of a word in transit will not give a false meaning to the message. For instance, if the word HAMID stands for 1000 and HABID for 2000 an error of transmission changing the M into a B might lead to the shipping of twice as many goods as were ordered.

Another illustration actually taken from the private code of a firm of electric cable makers is in the word LEAPED, signifying "hold order for instructions", and LEANED meaning "hurry forward goods on order." It is easy to see what trouble might result from a mix-up in transmission in this case. If however, every word is two letters different it is in the last degree unlikely that both would be so transpos-

2240 lbs., the ton being derived from the old English beer measure of a ton, same being 209 gals., or about 2,200 lbs. Owing to the fact that some materials are very much lighter than others, it was found necessary to charge freight on the cubic capacity of the goods with their cases, and, at the present time, the "ton" referred to in freight quotations means nothing more or less than forty cubic ft. The weight basis still remains for heavy or bulk cargoes, but, for all ordinary freight, it is necessary to measure up the outside dimensions of the boxes or crates, estimate the space they will occupy in the hold and to divide the result by forty.

Register Tonnages

A ship has two register tonnages which are attached to her name in Lloyd's Register, these being "Gross" and "Nett." Both are measured in units of 100 cubic feet, or just 2½ times the freight unit. Gross tonnage is measured as the whole of the space below decks, plus the capacity of deck cabins, chart houses, and other covered structures. Nett tonnage is the difference remaining after deducting the quarters for the officers and crew, navigation and engine space, and bunkers. In other words, nett tonnage is the maximum hold capacity. It varies from 50 to 70 per cent. of the gross tonnage in an ocean going cargo steamer, and, as the cost of a ship is directly related to her gross tonnage whilst her earning capacity is a function of the nett ton-

tors endeavor to keep the weight between 26 lbs. 12 oz. and 26 lbs. 8 oz. If shells are under this low limit, a tag is attached to the groove to indicate that shell is to be fitted with a hot band. The source of error lies in the fact that no means of checking is available, as miscalculation when marking amount to be removed is not discovered until the shells are practically completed.

Washing and Varnishing

Washing is performed by a jet of steam entering the nose when shells are submerged in a solution of sal soda. Varnish is applied by means of a brush through the nose of shell, the threads being protected by a brass ferrule, shown in Fig. 14. After this operation the shells are again hand tapped to remove surplus varnish.

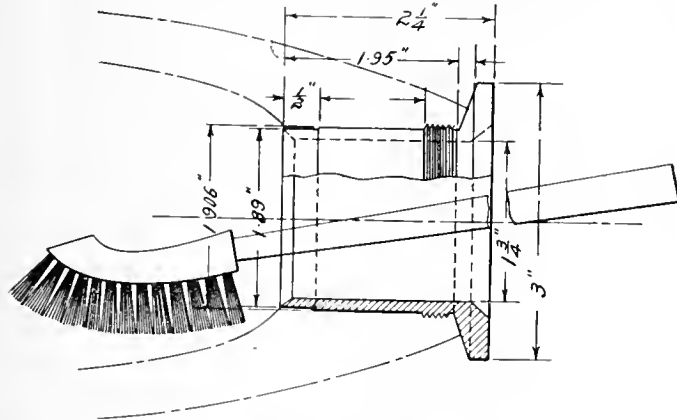

FIG. 14. VARNISH THIMBLE AND BRUSH.



FIG. 15. PAINTING MACHINE AND DRYING RACKS.

Banding and Painting

Copper band operations are similar to those on other shells; the press having been supplied by the International Engineering Works, Amherst, N.S., and the turning lathe by Jenckes, Sherbrooke, Que. A record production on the lathe is that of 925 shells in 11 hours. When shells pass the final inspection they are

ed as to give a false meaning, and, in nearly every case, an error would lead to an unintelligible message which the receivers would promptly have repeated.

Let us take as the root for our code the letter K; this can be followed by any of the five vowels, KA, KE, KI, KO, KU. Now, eliminating the inconvenient letter Q, there are twenty consonants which combined with the above will yield 100 different three letter words; viz. KAB, KAC, KAD, KAF, etc. Lastly comes another vowel and consonant, both of which must change with every word; viz. KABAC, KABED, KABIF, KABOG, KABUH, next, KABJA, KABKE, KABL, KABMO, KABNU, and then KACAP, KACER, etc.

The above illustrates sufficiently the method to be adopted in making up any arbitrary code which shall satisfy all

and the words can be made up just as fast as one can write them down.

In attaching meanings to the words, it is useful to let the three letter root denote a class of product and the suffix stand for the size or type. For instance, KAB-may be taken to mean "engine lathe," and the suffix-AC would be 10 ft. bed, or ED 12 ft. bed. KAC-might signify a riveting gun, AP being 1½ ins. size, ER 5/8 ins. etc. Such a code as this would dwell in the memory and

	B	C	D	F	G	H	J	K	L	M	N	P	R	S	T	V	W	X	Y	Z
A	00	05	10	15	20	25	30	35	40	45	50	55	60	65	70	75	80	85	90	95
E	01	06	11	16	21	26	31	36	41	46	51	56	61	66	71	76	81	86	91	96
I	02	07	12	17	22	27	32	37	42	47	52	57	62	67	72	77	82	87	92	97
O	03	08	13	18	23	28	33	38	43	48	53	58	63	68	73	78	83	88	93	98
U	04	09	14	19	24	29	34	39	44	49	54	59	64	69	74	79	84	89	94	99

might find a certain use in private correspondence, stock lists and card indexes, thus saving much time and space.

through the Western Union, Liebers, or A B C 44th, or 5th, edition, it will be seen that a small proportion of the words are numbered from 100,000 up. This system will only apply to the first 99,000 words so those eliminated should be carefully noted; in any event the method covers the most useful part of the code book. By the use of the following table it will be seen every number from 0 to 99,000 can be represented by a pronounceable word:

In above table, each number is represented by a vowel and a consonant, in other words by a pronounceable syllable; for instance 36 is KE (or EK). 53 is NO (or ON). To use the table let us take an actual message from the Western Union Code.

34628—Goods were improperly packed.

4162—Will not hold ourselves liable.

Putting these two numbers together in this way, 34-62-84-41-62, and substituting the proper letters from the table, we obtain JURIWULERI, which in one word carries the same message as the two words in the code. The receiver of such a message will just substitute the figures for the letters, divide the ten integer number into two of five integers each, and look up the meaning in the Code Book. It will be seen that, to represent such a number as 83, the symbol 00083 must be used so as to leave no blank spaces.

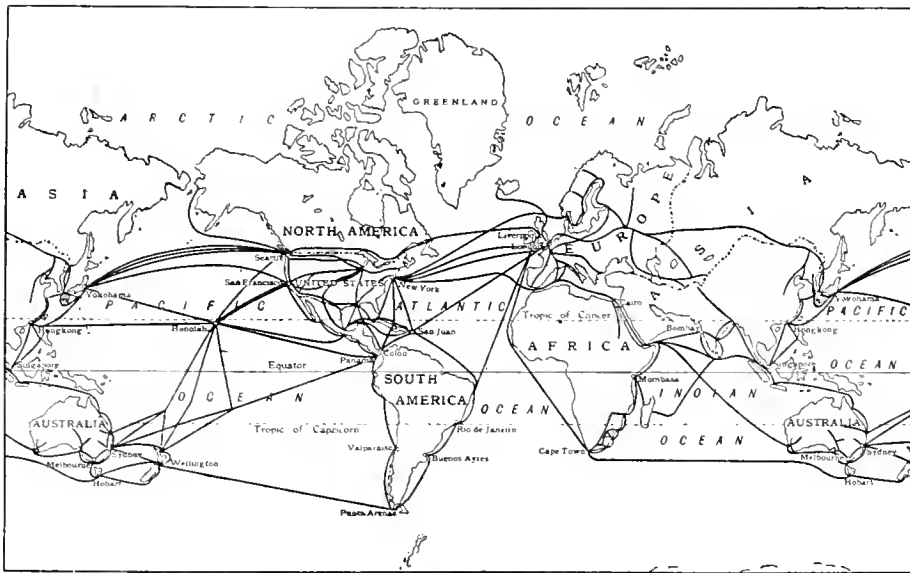

SHIPPING ROUTES AND MILEAGE TABLE OF DISTANCES, SHOWING SAVINGS EFFECTED BY PANAMA CANAL PASSAGE.

Distance from New York to Sydney, Australia, via Straits of Magellan	12,546
From New York to Sydney via Panama	9,814
Saving	2,732
Distance from New York to Hong-Kong via Suez	11,400
Distance from New York to Hong-Kong via Panama	11,415
Saving	45
Distance from New York to Yokohama via Suez	13,040
Distance from New York to Yokohama via Panama	9,835
Saving	3,205
Distance from New York to Honolulu via Straits of Magellan	13,269
From New York to Honolulu via Panama	6,687
Saving	6,582
Distance from San Francisco to New York via Straits of Magellan	13,060
From San Francisco to New York via Panama	5,299
Saving	7,761

the rules. It may be asked "why not choose ordinary five-letter dictionary words?" The objections are that considerable search would have to be made to ascertain that the words were not already in use in a standard code, and further, with a large list of words it would be a most laborious process to go through them in order to see that they fulfilled the "two letter change" rule. With the devised code above described, this automatically takes care of itself

In telegraphing such a code as this two words are always connected regardless of meaning, thus, KEDOBKABMO becomes KEDOB, KABMO, for decoding.

Standard Code Modification

Economy and secrecy are also obtained in cabling by modifying one of the standard codes according to a prearranged plan. This involves using the numbers which are attached to all the words in the code book. Looking

ELECTRIC LIGHT AND POWER AT EDMONTON, ALTA.

THE new C.N.R. shops and roundhouse are now electrical, the installation of a complete electrical power plant having been completed this week. The plant has a capacity of 125 horse-power withing the next three months. All the machinery in the repair and car shops will now be driven by current from Edmonton city service. A similar installation has recently been completed in the shops and roundhouse of the Grand Trunk Pacific at Calder, where 200 horse-power is now in use. The G.T.P. shops have also been electrified for lighting.

The addition of the two railway shops to the list of the city's customers indicates a somewhat general move on the part of local manufacturers to substitute electrical for steam power. Since last July the commercial section of the civic light and power department has installed electrical power plants totalling over 990 horse-power, including the factories and shops of the Western Canada Flour Mills, Edmonton Brewing Co., Cushing Bros.' woodworking mill, P. Burns Co., J. J. McLaughlin Co., and Edmonton Steam Laundry. The largest of these installations is that of the Cushing plant, which has 400 horse-power. A number of other firms are interested.

PRODUCTION METHODS AND DEVICES

A Department for the Interchange and Distribution of Shop and Office Data and Ideas Evolved from Actual Practical Application and Experience

SOLVING A MECHANICAL PROBLEM

By D. O. Barrett.

THE mechanism to be discussed in the following article is that of an oil engine governor. While the oil engine, itself, has no direct bearing on the subject, yet in order to fully understand some of the principles involved, an understanding of the operation of the engine will be of assistance. In this type of engine, not only gasoline and kerosene, but the heavier oils, such as fuel oils and crude oil, may be used. The fuel is injected directly into the combustion chamber of the engine, by means of the fuel pump, against some heated surface, this vaporizing the oil and firing the mixture. The timing of the injection of the oil corresponds to the timing of the ignition in the ordinary gasoline engine. These engines are governed by varying the quantity of oil which is injected into the cylinder during each working stroke. In nearly all cases, the fuel pump is operated through the medium of an eccentric located on the engine crankshaft.

There are several well-known and successful methods of governing the amount of fuel injected, but the simplest, and the one most commonly used is that in which the stroke of the fuel pump is varied to suit the load; in other words, with a heavy load, the fuel pump will have a longer stroke, while at the lighter loads the stroke of the pump plunger will be shortened in proportion. To accomplish this result, there are also several successful methods, but the one most commonly employed is that in which the eccentric on the engine shaft is moved across the shaft so as to increase or decrease its effective throw. In the discussion following, only the mechanical problems pertaining to the governor mechanism itself will be discussed and not its relation to the engine proper.

Single Arm Design

In Fig. 1 is shown an outside view of the first governor used, also the eccen-

tric proper; and in Fig. 2 is shown a cross-section through same, from which the principle of operation may be plainly understood. As the governor arm moves out, this angular motion is imparted to the governor crank which in turn force the eccentric in toward

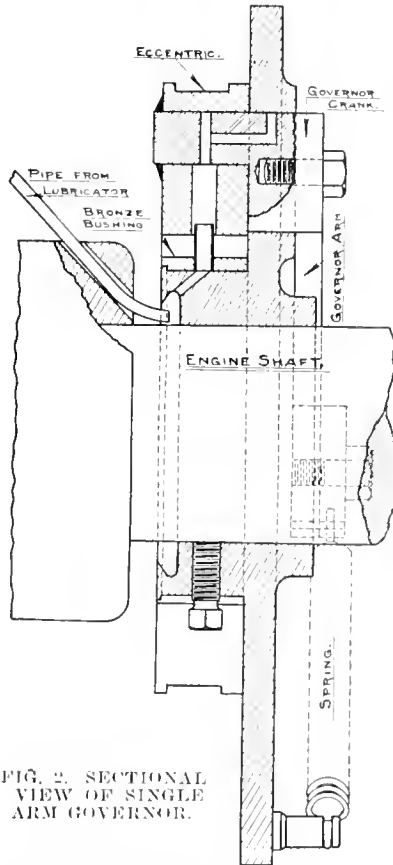

FIG. 2. SECTIONAL VIEW OF SINGLE ARM GOVERNOR.

the shaft, decreasing its throw. This governor was of fairly simple construction, as is evidenced from the few parts used. The governor plate or main body was bored out to slip over the engine shaft and was held in place by two set screws. Around the turned hub of the plate was a bronze bushing which is

shown quite clearly in Fig. 8. Two opposite sides of this bushing were planed parallel to fit the inside of the eccentric. In order to maintain the bushing in position and not interfere with its freedom of movement, a groove was turned at the outer edge to conform to a slight shoulder at the end of the governor plate hub. This bushing, being open at the one side, could be spread apart slightly and then slipped over the shoulder. The eccentric was a solid casting and was machined on both sides. A groove was turned around the outer face leaving a slight shoulder on either side to maintain the eccentric strap in position, this being also of cast iron. The primary purpose in leaving the centre of the eccentric entirely open was for ease in machining, this operation being performed on the shaper. The opening, being relatively large, would, quite naturally, interfere with the lubrication of the strap to some extent, as the sharp edges would wipe off the oil.

Development of Excessive Wear

The holes for the governor crank in both the plate and eccentric were drilled and reamed directly in the castings. Over the small end of the crank was riveted a steel washer, this keeping the parts together. As the total angular movement of the governor arm from full load to no load was over 60 degrees, there was considerable wear in the crank holes both in the plate and eccentric, and these were later brass-bushed. Stock tubing was purchased one-eighth inch in thickness and, after being pressed into the previously reamed hole, was again reamed to fit the crank.

The system of lubrication is quite clearly shown in the sectional view. Around the inside of the governor plate is turned a groove, clearing the shaft sufficiently to allow the insertion of a small copper tube from the force feed lubricator; from this groove a hole is drilled at an angle up to the centre of the bronze bushing into which is tapped a short piece of one-eighth inch

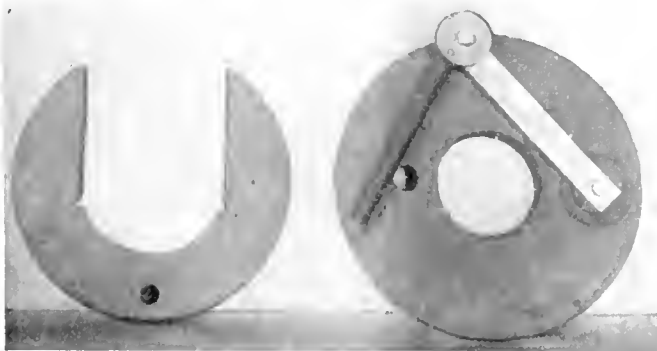

FIG. 1. VIEWS OF ECCENTRIC AND EXTERIOR OF FIRST GOVERNOR WITH SINGLE CRANK ARM.

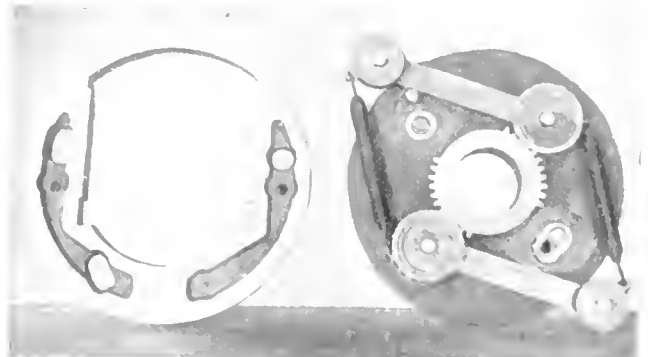

FIG. 3. VIEW OF ECCENTRIC BRIDGED, AND GOVERNOR WITH TWO CRANK ARMS.

pipe, this extending up into a larger drilled hole in the eccentric proper. As the eccentric and bushing move around the shaft in unison, the eccentric will have an in-and-out movement over the pipe. Holes are drilled through the governor crank as shown so that the oil reaches both the eccentric and the plate. This system of lubrication has worked very satisfactorily and has not been changed on any of the succeeding types of governors.

Dummy Arm Introduced

These governors proved fairly satisfactory for the ordinary run of work, such as irrigation or for factory purposes. It was found, however, that they were not sufficiently sensitive for exacting service such as electric lighting. One disadvantage which soon became evident for this class of work and especially with alternating current, was that the engine would be allowed to race or

den changes in the load, the teeth in the central gear broke quite rapidly and these were then cast of brass. The method of fastening the springs was still as shown in Fig. 1, where the outer loop was simply slipped over the end of the

der bushings are used on these screws, the plate being spot-faced for the shoulders, and also slotted sufficiently to allow for the throw of the eccentric.

After putting out a large number of these governors to operate under practically all conditions, considerable trouble was reported from the breakage of loop ends of the governor springs. Should the spring happen to break on the dummy arm, the sudden strain on the gear teeth would cause them to break, and if damage were done to the larger gear, it was necessary to remove the fly-wheel to replace it, so that this was more serious than might at first appear. In Fig. 5 are shown the two types of springs used. That shown at (a) would continually break at the beginning of the loop just after leaving the coil. In the later type, the loop was entirely separate from the coils, the inner end of the loop being provided with an eye around which the coils were closed. Of course, this decreased slightly the effective length of the spring, but the trouble from breakage was entirely eliminated.

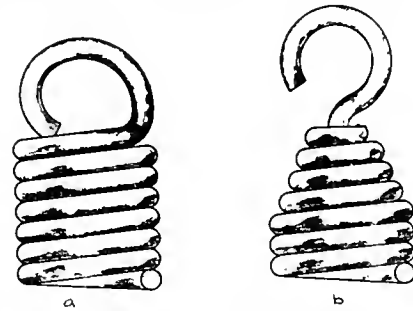

FIG. 5. (a) TYPE OF SPRINGS FIRST USED. (b) IMPROVED TYPE.

stud in which was turned a groove.

The weights used on the first governors are shown in the upper drawing in Fig. 4. These weights were quite expensive to make as they were machined all over, and were also milled-out to slip over the governor arms, these arms being of 1 1/2-in. by 2-in. cold drawn steel. A slot was also milled into the weight at the one side into which the loop of the spring could be slipped and held by a cotter pin, through the drilled hole. To change the speed of the engine, weights of various diameters were used, the thickness of the weight remaining the same. There was, thus, no adjustment directly on the spring. After the balancing arm was used, it was found that the momentary variation was taken care of, but there was still quite a drop in speed from no load to full load, due, no doubt, to the extreme distance through which the weights moved. After considerable experimenting it was found that, by attaching the stationary end of the governor spring to the end of the opposite governor arm, this condition was to a large extent remedied. To accomplish this in the easiest manner, a heavy link chain was attached to the end of spring, and extending partly around the small gears, was held in place by a small cap screw. The steel washer, for-

Eliminating Noisy Operation

After adopting the new spring, it was found possible to change the style of weight used; as shown in the lower drawing in Fig. 4. These weights were cast in various thicknesses, three being ordinarily used. They were relieved at the centre and disk ground on the sides. The position of the weights on the arm could be changed so as to increase or decrease the tension of the springs, so that quite wide changes of speed were possible without changing the weights. Of course, only one of the weights was provided with the extension into which the spring was hooked.

After being in operation a short time, these governors became exceedingly noisy; this was occasioned from the extreme wear which occurred, due to the short bearings which were necessary on the main crank, both in the plate and eccentric, as well as on the dummy crank. The oil fuel was injected into the engine cylinder under a pressure of about 2,000 pounds per square inch,

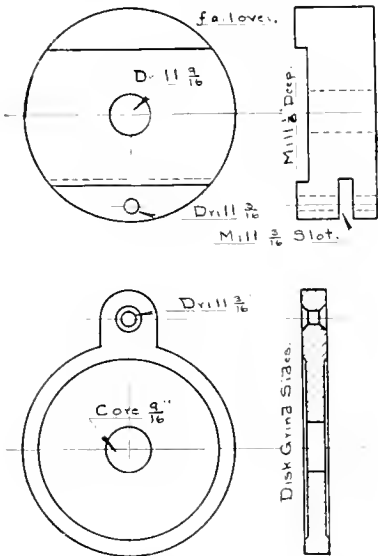

FIG. 4. GOVERNOR WEIGHTS.

“peg-leg,” producing a flickering in the lights which was decidedly uncomfortable to the eyes. An effort was made to overcome this by adding a frictional device which prevented the free movement of the eccentric relative to the plate, but the relief was only temporary. Finally, another governor arm was introduced, as shown in Fig. 3; as this arm and its crank was not directly connected to the eccentric, it acted merely for balancing purposes, and was known as the dummy arm and dummy crank. The dummy crank was in reality no crank at all, but merely a straight piece slotted for the arm at the one end and provided with a shoulder at the inner end. In order that the two arms should work in unison, the central gear was placed on the extension of the plate hub and smaller gears placed over the ends of the cranks and governor arms, the same screw extending through both. These gears, in the beginning, were all of cast iron with cast teeth. Over the smaller gears were placed steel washers, these acting as shrouds to hold in the central gear. Due to sud-

merly used on the end of the gear was replaced by a shroud cast directly on the gear. Not shown clearly in the view of the first governor was the method of keeping the eccentric and plate together; in Fig. 3 will be noticed the two cap screws which extend through the plate, and are tapped into the eccentric. Shoul-

which, on a plunger of three-fourths inch diameter, gives a total pressure of nearly 900 pounds against the eccentric and strap. As this occurred at every revolution, the engine being of the two eyelet type, it will be seen that the governor was subjected to extremely heavy service. Not only the brass

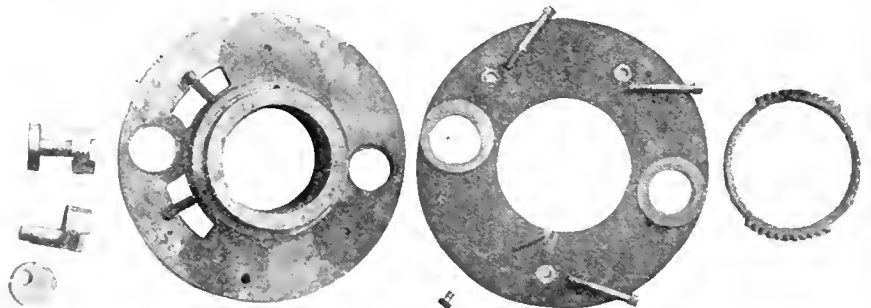

FIG. 6. FRONT AND MAIN PLATE.

bushings gave trouble, but it was also impossible to keep the shoulder bushings in adjustment; this caused a separation of the plate and eccentric at every revolution with a characteristic "knock."

The only possible solution seemed to be to arrange the cranks with a bearing at each end so that the pressure would be absorbed between these two points, thus avoiding the twisting strain which proved so detrimental. To do this it was necessary to add another plate. The main governor plate was moved to the back and the removable plate placed at the front where it would be more accessible. These are shown in detail in Fig. 6. The front plate was machined on the inside surface and bored to the same diameter as the large brass gear. The main hub still carried the same two diameters, one for the gear and the other for the bronze eccentric bushing, which was bored the same as before, but with the groove omitted, as it was securely held between the two plates. It was also possible to omit the shoulder at the side of the eccentric, allowing the strap to run freely between the two plates; this also allowed the bearing surface to be widened a corresponding amount. The front plate was fastened to the main plate by the three screws shown, around which were placed bushings of the same length as the hub, and providing a slight clearance for the eccentric and the bronze bushing. A single dowel pin was used at the centre to insure proper alignment of the plates. The plates were drilled and reamed for the cranks after being bolted together, and with the dowel pin in place.

In Fig. 7 are shown the two cranks, the method of constructing the live crank being quite clear. The outer end was placed on the crank and the two

the same lathe fixture. The dummy crank was first made from cold drawn steel of the proper diameter, but as this material became extremely difficult to secure, it was later made from cast iron, and no breakages occurred.

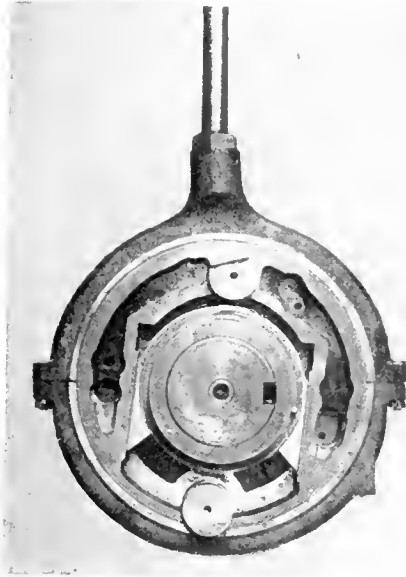

FIG. 8. ASSEMBLED GOVERNOR

Eccentric Opening Bridged

The open portion of the eccentric was now bridged and relief for the tool cut at each end. The castings were also lightened by coring out on either side. Slots were cored sufficiently large to clear the screws holding the plates together. The bridge across the eccentric also served the purpose of holding in the dummy crank, as the inside edge never cleared the crank even at its outer position.

In Fig. 8 is shown the assembled governor with the front plate, and arms

as is evidenced from an examination of many of the older machine tools. The two halves were cast in the one piece, and after boring and facing, were split on the milling machine, liners being used for adjustment. While the improved governor still retained the elements of mechanical simplicity, yet the many added features quite naturally increased the shop cost to a considerable extent. The results obtained in the field, however, amply repaid for any additional cost, as the replacements and repairs have been reduced to a minimum.



SIMPLE MULTIPLE CLAMPS

By F. Scriber.

It is almost invariably an objective point in designing tools to grip as many parts as possible with the least effort, or with the least amount of rigging, but seldom is it possible to accomplish this in an effective manner, as the general run of work is of such a character as to call for a clamp on each part or its equivalent.

The purpose of this article is to describe three simple arrangements for clamping a number of pieces. Referring to Fig. 1, the illustration shows a

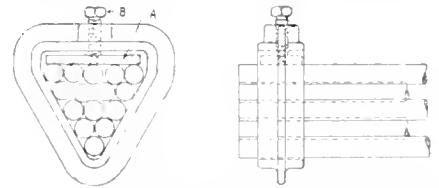

FIG. 1. VEE TYPE OF BOX CLAMP FOR GRIPPING ROUND BARS.

number of round bars which are to be cut off. These are held in what is known as a vee clamp, and the manner of using this clamp is obvious, as in gripping the work the strap A which is brought into contact with the work by the screw B, forces all the bars down until the parts are wedged one against the other and in this manner they are all held by the one screw.

A rather convenient clamp for gripping a number of flat strips of stock is illustrated in Fig. 2. In this illustration the stock is shown in section and the number of strips illustrated is eight, the clamp is made up of a number of rolls, the illustration showing fifteen, eight in the lower row which bear on the stock, and seven staggered between these rolls and the upper portion of the clamp. All of these rolls are permitted to float up and down in the clamp and are prevented from falling out by two plates, at the bottom of the clamp, upon which the lower rolls rest when the clamp is not in contact with the work, this object being attained by having pins in the lower set of rolls B, which protrude about 3/8 of an inch beyond the rolls and thus prevents the rolls from falling out of the box portion of the clamp C.

In gripping the work the nuts D on the two screws which fit into the free slots of the machine table are tightened,

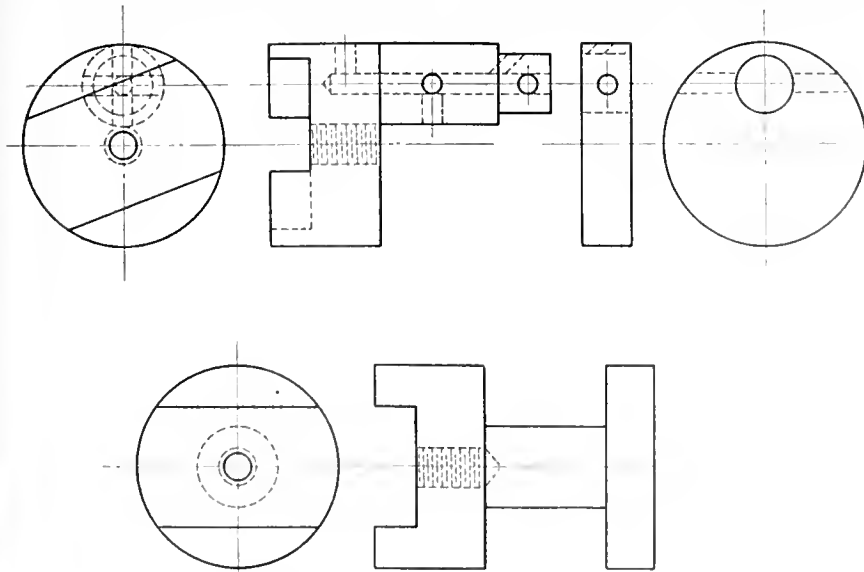

FIG. 7. CRANKS FOR DOUBLE PLATE TYPE GOVERNOR.

pieces inserted in a jig bored to the same diameter where the hole through the two was drilled and reamed for larger taper pin. In order to insure the throw of each being the same, both crank and end piece were finished in

and weights removed. The eccentric strap was of cast iron, although many designers would object to the use of this metal in the above instance. Where the bearing surfaces are properly lubricated no better combination can be obtained,

this causes the upper set of rolls to be forced against the plate E and the lower set of rolls are thus wedged against the nuts of the box portion of the clamp F, and the upper set of rolls. This con-

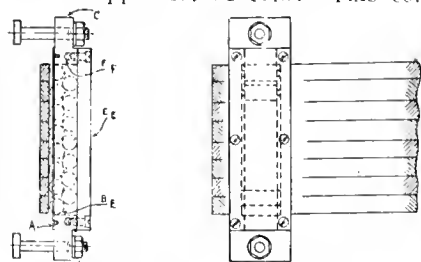

FIG. 2. ROLL CLAMP FOR GRIPPING A NUMBER OF FLAT PIECES.

struction makes a floating clamp and in this floating condition one strip cannot be bound until all of the strips are gripped. This clamp is very efficient and can be made to grip successfully quite a number of flat strips.

Having described a clamp for gripping round bars and a clamp for gripping flat bars, the concluding illustration shows a jig for drilling balls. In the lower part of Fig. 3, a ball is shown which has been drilled. In drilling these balls, it is necessary to handle more balls than what are actually being drilled. The jig used for this purpose is simple in construction and consists of the base A, which is chambered to receive the balls. In addition to this there is a plate B which contains a number of holes countersunk on the under side, the other parts of this jig are a washer C, a binding nut D, and a screw E.

Having arranged the balls in the chamber of the jig in the manner shown the ring is placed over the screw and is tightened by the nut. In doing this a number of balls are centralized in each countersunk hole until all the balls are clamped in place, when we proceed to drill in the usual manner using the holes through the plate to guide the drill through the centre of the ball.

While primarily these three parts, namely Round Bar, Flat Bar, and the Ball, are parts which can be easily machined one at a time, with the tools

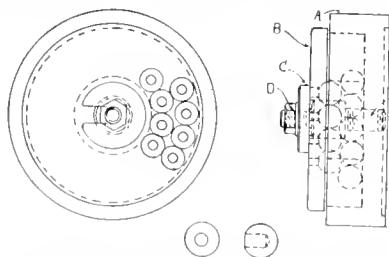

FIG. 3. JIG FOR DRILLING HOLES IN BALLS AND SHOWING BALL AS DRILLED.

shown, the various illustrations make it evident that these parts can also be machined in quantities even more economically.

DRILLING BASES OF 4.6 INS. H.E. SHELLS

By R. Hamilton

WHEN the manufacture of 18 pdr. high explosive shell was being dis-

continued, many firms were somewhat at a loss as to the disposal of much of their equipment. Where machinery could be adapted to the production of the heavier shells the problem was easily solved, but to find a satisfactory use for the heavy upright drills required special ingenuity on the part of plant executives. The accompanying cut shows a Foote-Burt drill fitted up to bore out the base of the 4.5 inch high explosive shell. A special swing clamp chuck is secured to the table of the drill press; the upper end being fitted with a ring plate to steady and align the cutter while operating. The cutter is of the multiple type removing all the metal at one sitting. Three of these drills have been equipped in this manner and their average production is about 160 shells per day.

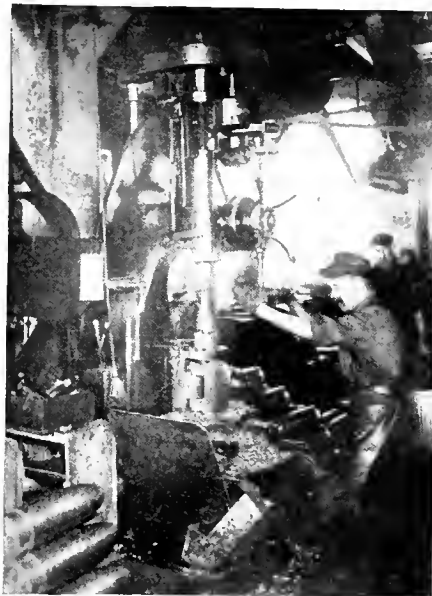

DRILLING BASES OF 4.5 INS. HIGH EXPLOSIVE SHELL

SOUTH AFRICAN TRADE NOTES

There are now 206 bookstalls on the South African railways.

Some 900,000 acres of land are under irrigation in South Africa.

Some 1,593 locomotives are at work on the Union railways.

Most of the bedsteads in South Africa come from the United Kingdom.

Facilities for handling coal at the Cape Town docks are to be materially increased.

The largest explosives works in the Cape Province pays over \$500,000 a year in wages.

The gold industry of South Africa distributed in 1915 over \$67,500,000 in wages and salaries.

One Natal firm is now treating 50 tons daily of green bark in the manufacture of wattle extract.

The railways now being operated in what was German Southwest Africa have a total length of 1,521 miles.

The total value of the gold output of the Witwatersrand since discovery to the end of 1915 was \$2,270,000,000.

There is a good business done in Cape Town in the construction of motor-car

bodies and side-cars for motor-cycles.

The National Bank of South Africa, Ltd., have now opened branches at Mombasa, Nairobi, Tanga, and Dar-es-Salaam.

All ordinary harness is now being made in South Africa. This is a local industry which will probably show surprising growth.

The demand for heavy boots in South Africa is increasing enormously now that the natives are generally adopting footwear.

In normal times, Joburg drew a lot of its sugar from Mozambique, but the bulk of the crop has now been diverted to London.

At Blantyre, Nyasaland, the cotton and tobacco markets are strong, rubber is stationary, and tea is lower than it was early last year.

It is expected that the production of citrus fruit within the Union will reach 1,000,000 boxes in 1917. The export trade is steadily growing.

Cape Town has ample funds in hand to meet all capital expenditure for some years. The new drainage and water schemes will involve contingent liabilities.

The Livingstone (Northwest Rhodesia), Farmers' Co-operative Society are now responsible for the purchase of all implements, dips, salt, grease, oil, etc., required by members.

Much South African cheese is finding its way to the Joburg market now, and, owing to the gradual improvement in the make it is largely taking the place of the Dutch imported article.

As indicating the commercial importance which British East Africa is assuming, no fewer than 34 travellers' licenses were issued at Nairobi during the quarter ending September last.

The cost of iron and steel, Baltic timber, and galvanized iron, imported from oversea for the use of the South African railways has increased 100 per cent. during the war. Pitch pine is 150 per cent. dearer.

A few years ago, South Africa imported annually \$1,600,000 worth of butter and \$500,000 worth of cheese. Imports of cheese are now diminishing, and the imports and exports of butter nearly balance.—British and South African Export Gazette.

CYANIDE IN CANADA

AT the meeting of the Society of Chemical Industry in Montreal recently, a report on the cyanide situation, important to the gold mines of the country, was read. It was shown that this important chemical could be made available in Canada, and the hope was expressed that some of our Canadian manufacturers would avail themselves of the shortage in the market to establish plants in Canada. Mr. Wardleworth, chairman of the Canadian section, stated that word had been received by Sir George Foster from the British Government to the effect that enough cyanide to keep the mines going would be exported to Canada provided the shipping facilities permitted.

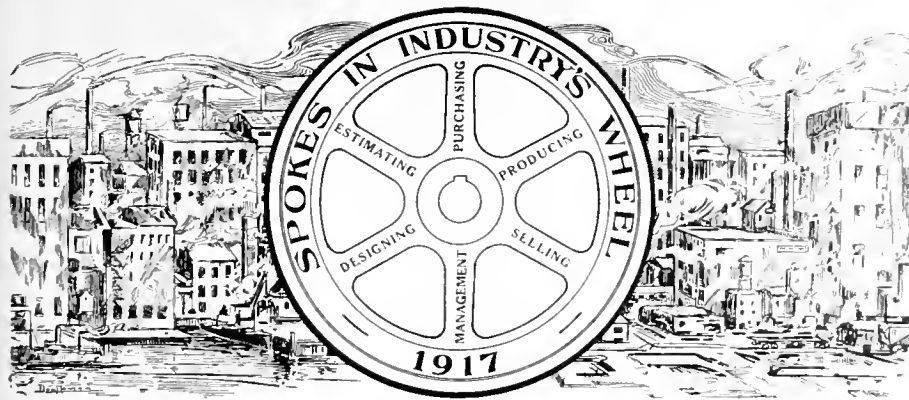

The constitution of industrial enterprise is largely departmental—"spokes in a wheel." This series of articles has for its object the featuring in a racy, interesting and instructive fashion, the training, experience and achievement of those who to-day are transmitting, effectively, energy in their capacity as "spokes in the wheels" of our metal-working establishments.

KARL E. BARRETT

It was among the green hills of Vermont State, in the town of St. Johnsbury on the 4th day of October, 1886, that Karl E. Barrett, superintendent and chief engineer, E. & T. Fairbanks Co., Sherbrooke, Que., was born. Being born and brought up in the town which is the home of the Fairbanks scale, it is not strange that we find him to-day an expert in scale design and manufacture.

In 1903, after leaving the public schools, he started his technical training in St. Johnsbury Academy, from which he graduated in 1907, ranking high in his studies as well as in athletics. He had been captain of both the baseball and basketball teams, and, through his enthusiasm and determination, winners in both cases had been placed in the field.

He took his first business appointment by engaging with the E. & T. Fairbanks Co., during his summer vacation in 1905, being employed in their valve department. Although but 19 years of age, he applied himself so efficiently in operating the turret lathes on the manufacture of valves that his efforts showed increased production comparatively; consequently when an operator was off on his annual holiday, Barrett was given the particular machine to run during the interval. When given these opportunities, he did not content himself with turning out the same production as the regular operator, but put his entire energy and resourcefulness into increasing the output where possible. In this way he made a reputation for himself during the two summers devoted to this work and showed that he was as big as the jobs given him. After graduating in 1907 he started to serve a two year's apprenticeship with the Fairbanks Co., on the manufacture of scales. Having his mind made up however, to become a mechanical engineer, and not being financially equipped to enter college, he set out to obtain by long hours of hard study what knowledge he would have secured could he have entered a college for training.

When he had served his apprenticeship in the shops, he was given an opportunity in the engineering department, and while there his shop experience and the engineering knowledge being acquired soon won distinction for him: as a result, after six months time, he was advanced to that branch of the engineering department which handled the designs of scales for Foreign Countries, as also scales for special purposes. While serving in this department he compiled original data relating to scale designs, also data on the Section Moduli of ree-



KARL E. BARRETT.

tangular forms which he submitted to *Machinery*, of New York, for publication. After this data had appeared in that journal, it was found so useful to designers that it was given four pages in *Machinery Handbook*, published

by the Industrial Press, 53,000 copies of which have been sold.

During the fall of 1911, he was transferred to the E. & T. Fairbanks Co., plant at Sherbrooke, Que., in order to institute and take charge of an engineering department there. With a view to developing a higher grade quality of mechanic, and to foster a greater intimacy with scale manufacture, Barrett started a night school during the winter of 1912, at which, every Monday night, from 75 to 100 employees gathered for instruction. Here they were taught the reasons for the different operations in the shop, how and why these should be carried out as directed, and concerning the part each piece played in the welfare of the scale. A small model for demonstration purposes, one-twelfth (1-12), actual size was built by our "Spoke" in his spare time illustrative of a 20 ft. two section track scale, from which, when finished and erected, and a miniature loaded freight car run on, actual weights were obtainable.

In 1914, Mr. Barrett was given the title of Chief Engineer; his systematic handling of the work in that capacity resulting in the establishment of an efficient engineering department. Among the new designs of scales developed by him for special weighing purposes might be mentioned the 300 lbs., Even Balance-Shell Scale for weighing the 6 ins., 8 ins. and 9.2 ins. high explosive shell. This apparatus, we are informed, represents a remarkable achievement in scientific scale construction, enabling the operator to weigh three shells per minute by the rolling process. The scale being provided with a relieving attachment is preserved from hard use due to the impact of the shell as it rolls on-to and away from the platform, thus ensuring maximum life to the various component members, and enabling the sensitiveness of the mechanism as a whole to be retained. The scale when fully loaded is sensitive to 1 dram. A similar design of scale is manufactured for weighing 18 pdr. shrapnel, 4.5 ins. and 60 pdr. high explosive shells. Our "spoke" was appointed Superintendent, in addition to Chief Engineer, in 1916.

Mr. Barrett's pleasures in life are shared by his wife, who became Mrs. K. E. Barrett, 8 years ago. Outdoor sports claim a place in his life, as he enjoys motoring, fishing and hunting. To Y.M.C.A. work he devotes much of his spare time. His fraternities are Passumpsic Lodge, No. 27 A. F. & A. M.; Haswell Royal Arch Chapter No. 11, R.A.M., Palestine Commandry, No. 5 K. T.; and Mt. Sinai Temple No. 3 A.A.O. N.M.S., the third oldest shrine temple in North America.

Mr. Barrett attributes his success to the systematic reading and study of technical and industrial magazines, and technical books. He encourages his men to do likewise and makes a point of seeing that they take copies of such publications as bear both directly and indirectly on their work and welfare. He is strong in his encouragement of men to take Correspondence School Courses.

EDITORIAL CORRESPONDENCE

Embracing the Further Discussion of Previously Published Articles, Inquiries for General Information, Observations and Suggestions—Your Co-operation is Invited

MECHANIC'S INSTRUCTION COURSE—XIV

By J. Davies

IN some cases there are two gears built into lathe, which are practically fixtures, one on lathe spindle and the other gearing with it inside the frame; there gears are never or very rarely removed and must be taken into consideration in figuring out the gears. When a lathe is made with a pair of gears that are not intended to be removed, they are invariably made a definite proportion to each other usually 2 to 1 or perhaps 3 to 1. In cases of this kind the easiest and simplest way to work out change gears is to multiply the number of threads per inch in guide-screw, by the ratio of the two fixed gears, proceeding as mentioned in previous articles.

Example: Find wheels to cut 6 threads per inch with a leading screw 5 threads per inch, with a fixed wheel on the lathe spindle of 30 teeth, gearing with a wheel containing 60 teeth. The ratio of the fixed wheels is 30/60 or 2 to 1. Rule: multiply threads in lead screw by ratio of gears $5 \times 2 = 10$. Ignore the fixed gears from now on, and assume that the leading screw has 10 threads per inch, proceeding as before. Thread to be cut 1/6, lead screw 1/10 invert and multiply

$$\frac{1 \quad 10 \quad 10 \quad 100}{6 \quad 1 \quad 6 \quad 60}$$

If the pitch to be cut is exceptionally difficult or if you are doubtful as to whether you can get any combination to cut the pitch required try this method of using prime numbers.

Prime Numbers and How to Find Them

This method of finding prime numbers or excluding the numbers that are not prime was invented by Eratosthenes 194 B.C. and is called Eratosthenes' sieve. To find the prime numbers in any series of numbers write in their proper order all the odd numbers contained in the series. Then reckoning from 3 place a dot over every third number in the series; reckoning from 5 place a dot over every fifth number; reckoning from 7 place a dot over every seventh number, and so on—the numbers remaining without dots over them together with number 2 are the prime numbers and cannot be divided by any other number.

Example: For a series of numbers up to 40, write down all the odd numbers in their order 1, 3, 5, 7, 9, 11, 13, 15, 17, 19, 21, 23, 25, 27, 29, 31, 33, 35, 37, 39. Start to count at No. 3, placing a tick over every third figure and so on as explained, the number unticked are 1, 3, 5, 7, 11, 13, 17, 19, 23, 29, 31, these together with No. 2 are the prime numbers. The following table of prime numbers will be found very useful:—

1, 2, 3, 5, 7, 11, 13, 17, 19, 23, 29, 31, 41, 43, 47, 53, 59, 61, 67, 71, 73, 79, 83, 89, 97, 101, 103, 107, 109, 113, 127, 131, 137, 139, 149, 151, 157, 163, 167, 173, 179, 181, 191, 193, 197, 199, 211, 223, 227, 229, 233, 239, 241, 251, 257, 263, 269, 271, 277.

Application of Prime Numbers

Required, wheels to cut .654 in. pitch, with a lead screw 3 threads to the inch:

(1) Find ratio according to preceding

$$\frac{.654}{1000} = \text{Pitch to be cut.} \quad \frac{1}{3} = \text{Pitch of lead screw.}$$

Invert pitch of lead screw, $\frac{3}{1962}$

and multiply, $\frac{.654}{1000} \times \frac{3}{1962} = \text{Ratio.}$

Take the numerator and divide it by the least prime number given in the table as many times as you can. Then by the next prime number and so on until you have exhausted the possibilities of further division; you have then got all the factors contained in that number: $1962 \div 2 = 981$; $981 \div 3 = 327$; $327 \div 3 = 109$.

$2 \times 3 \times 3 \times 109 = 1962$.
Treat the denominator in the same way. $1000 \div 2 = 500$; $500 \div 2 = 250$; $250 \div 2 = 125$; $125 \div 5 = 25$; $25 \div 5 = 5$.

$2 \times 2 \times 2 \times 5 \times 5 \times 5 = 1000$. In this example one of the factors is 109. It would therefore be impossible to cut the above pitch without a gear containing 109 teeth or a multiple of 109, as by referring to table of prime numbers we see that 109 is a prime number and cannot therefore be further divided.

Having found all the factors, arrange them into an equal number of groups for the driving and driven wheels, using as many wheels as is most convenient $(2X3 \times 3) \times 109$ $18X109$

An 18 wheel would be too small, so multiplying by 2 = wheels required.

Here is another example which is taken from actual practice. It is required to cut a thread .7854 in. pitch with a leading screw $\frac{1}{2}$ in. pitch. Proceed according to rule $\frac{.7854}{10000} \times \frac{2}{10000}$ ratio.

Using prime numbers to collect factors, take the numerator first: $15708 \div 2 = 7854$; $7854 \div 2 = 3927$; $3927 \div 3 = 1309$; $1309 \div 7 = 187$; $187 \div 11 = 17$.

$2 \times 2 \times 3 \times 7 \times 11 \times 17 = 15708$.
Collect factors of denominator the same way: $10000 \div 2 = 5000$; $5000 \div 2 = 2500$; $2500 \div 2 = 1250$; $1250 \div 2 = 625$; $625 \div 5 = 125$; $125 \div 5 = 25$; $25 \div 5 = 5$.
 $2 \times 2 \times 2 \times 2 \times 5 \times 5 \times 5 \times 5 = 10,000$.
From these factors a number of differ-

ent sets of gears can be obtained. Arrange them in any order and in any number of groups, taking care not to alter their relative values:

$$\frac{(2X2)X(3X7X11X17)}{(2X2X2)X(2X5X5)X(5X5)} = \frac{4X51X77}{8X50X25}$$

multiply the 4 and the 8 by ten = $40 \times 51 \times 77$ wheels required.

Cutting Millimeter Pitches With Inch Guide Screws

As given in most text books, 25.4 millimeters = 1 inch, or one millimeter = $\frac{1}{25.4}$ of an inch, multiplying by 5 to get 25.4

a whole number $\frac{1}{25.4} \times 5 = \frac{5}{127.0}$ in. According to Government standards, the error in this fraction is less than 1-10th of one thousandth of an inch, so that for all practical purposes this standard can be considered as absolutely correct.

To find wheels for millimeter pitches, first find fractional parts of an inch by multiplying the number of millimeters by 5 — then proceed exactly as before. Example: (1) required wheels to cut 10 millimeter pitch with a lead screw 4 threads to inch. $\frac{10}{5} \times \frac{4}{127}$ in. pitch of screw to be cut. Invert pitch of lead screw and multiply $\frac{50}{127} \times \frac{4}{127} = \frac{200}{127 \times 127} = \frac{2 \times 100}{127 \times 127} = \frac{80 \times 100}{40 \times 127}$

It will be seen by reference to table that 127 is a prime number and cannot therefore be further divided, so that the only change necessary to adapt a British lathe to cut millimeter pitches would be to have a special wheel of 127 teeth. Example: (2) Find wheels to cut 7 millimeters with a lead screw $\frac{1}{2}$ -in. pitch. $\frac{7}{5} \times \frac{2}{127} = \frac{14}{127 \times 127}$ wheels required.

In exactly the same way inch pitch threads can be cut on a lathe with a metric leading screw. Example: It is required to cut 8 threads to the inch on a lathe with leading screw 10 millimeters. Thread to be cut $\frac{1}{8}$ -in. pitch. Pitch of leading screw $\frac{10}{25.4}$. Invert and multiply, $\frac{1}{8} \times \frac{25.4}{10} = \frac{25.4}{80} = \frac{127}{400} = \frac{127}{4 \times 100} = \frac{20 \times 127}{80 \times 100}$

It may happen that after working out a set of gears it is impossible to gear them up. A simple method of testing whether a doubtful set of gears can be used or not, is with a rule and a small pair of compasses. Take an ordinary

rule and let each $\frac{1}{8}$ -inch represent 10 teeth; draw circles to this scale, of all the wheels intended to be used, in their relative positions, and it will be seen at once whether the wheels can be geared up or not.

Do not mesh the wheels too deeply. Many mechanics have an idea that the wheels must be meshed tightly to prevent backlash; this is a mistake and is a very fruitful source of broken teeth.



IMPROMPTU SHELL BORING MACHINE

By C. M.

SPECIAL shell machinery is undoubtedly the feature of present day activity, and hardly a week goes by without the advent of some addition to the large variety of tools now used for shell operations. In connection with these developments, the cut herewith may be of

FRENCH SUPPLIES OF RECONSTRUCTION MATERIALS

THE U.S. Commercial Attache C. W. A. Veditz, Paris, in a report to his Government published in the Commerce Reports, states that the French Minister of the Interior has just published the results of an investigation made under his direction concerning the supplies of building materials likely to be available for reconstruction work in France upon the conclusion of peace. Among the materials thought to be available in sufficient quantities are stone, brick, sand, cement, tile, building hardware, wall paper, and certain others of minor importance. It is believed that, for lime, iron pipe, street-paving materials, and sandstone, French production may be increased to a point that will meet the demands. In the groups of materials in which a shortage may be felt are plaster, timber and lumber, slate, structural iron and steel, heavy hardware, tin, zinc,

labour. It is, furthermore, stated by the Government that every effort will be made to have the work of reconstruction undertaken as far as possible by local concerns. It is of course generally understood that the Government will give financial assistance to all manner of reconstruction work in the devastated regions of France.



RUSSIA BUYING IN CANADA

RUSSIA will hereafter be represented in Canada by a Commissioner authorized to make purchases of war supplies of various kinds here on behalf of his country. The Commissioner, Col. Kovaleff, has arrived in Ottawa, and is opening up offices. Russia has been making large purchases of munitions and other materials on this side of the Atlantic through the Russian Supply Committee, whose president is General Zaluboffsky, and whose headquarters are in New York. She has, moreover, obtained a considerable quantity of goods, munitions and freight cars required in her military operations.

The Canadian Government has made representations to the Imperial Russian Government as to the opportunities for supplying its requirements to a greater extent by purchases in Canada and the advantages of trade between the Allies. Its efforts have been rewarded by the appointment of Col. Kovaleff, which is an event of importance to Canadian producers. The Canadian Government will give the Russian Commissioner all possible assistance in his work.



CANADA'S TRADE INCREASES RAPIDLY

CANADA'S trade for the month of January, according to a return issued at Ottawa on Feb. 20, increased by \$38,000,000 over January last year. Total trade for the month was \$177,946,907. Total trade for the ten months of the fiscal year amounted to \$1,878,284,697, an upshoot of approximately \$718,000,000 over the corresponding period of 1915-16.

January imports totalled \$72,323,074; increase, \$22,000,000. Ten months' imports, \$674,964,548; increase, \$280,000,000.

January exports, \$99,106,259; increase, \$16,000,000. Ten months' exports, \$1,203,320,149; increase, over \$437,000,000.

The big item of increase in domestic exports was agricultural products, which in the ten months grew from \$217,909,912 to \$340,002,369, and manufactures, which increased from \$166,414,552 to \$368,655,496. Of coin and bullion, which are computed in the grand total, the imports were \$2,928,278 in January and \$2,592,701 in the ten months, while the exports were \$1,423,489 in January, and \$196,200,607 in the ten months.

In the same period, mineral exports increased by seventeen millions to seventy millions, fish by two millions to a total of \$20,860,000, and forest products by four millions to \$49,833,800.

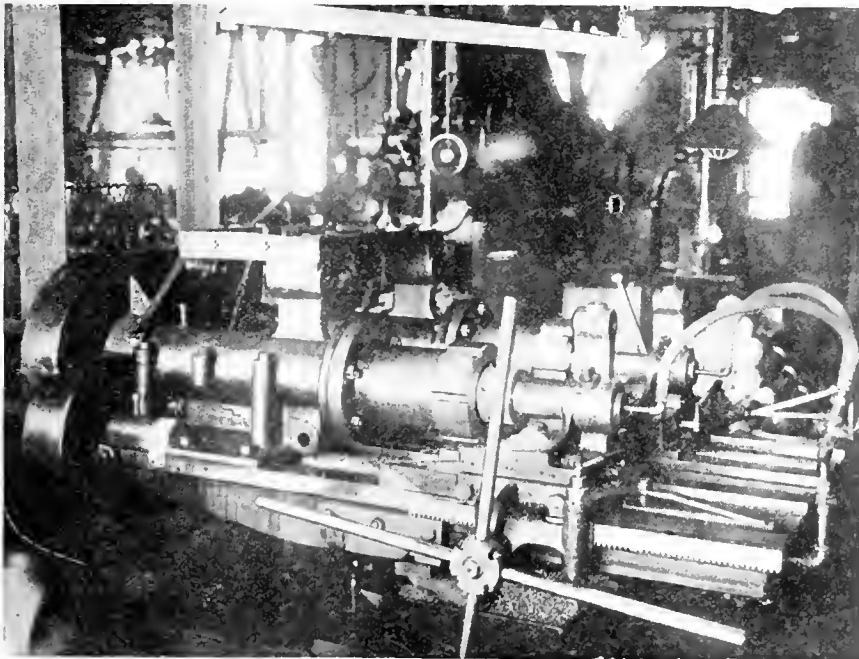

IMPROMPTU SHELL BORING MACHINE.

special interest, not as a new departure, but as featuring a Bertram shell boring machine designed originally for service on the production of the 18 pdr. H. E. projectile. The machine here shown has been overhauled and adapted for rough boring 4.5 inch, mark VII, shell. The machines have two spindles operating at the one time, the companion to that shown being designed so that each spindle can be operated independently; providing thereby increased facility for more rapid production. These tools are only used for roughing out the parallel portion of the bore, the finishing being completed on other machines. The lubricant is forced through the bar in sufficient volume to wash the cuttings clear. Automatic stops are provided, and only one man is required to keep the four spindles in constant operation. The two machines produce approximately 250 shells per day.

lead, plumbing supplies, pumps, sanitary appliances, heating apparatus, paint, and glass of all sorts.

It is reported by the Government that the necessary steps will be taken promptly to encourage the larger production of those materials of which there will undoubtedly be a very considerable need as soon as building operations are resumed on a large scale. These measures consist mainly of: The provision of facilities for obtaining the necessary equipment for producing building material; the resumption of operations in plants that were shut down; the resumption of the exploitation of mines and quarries; the reopening and improved equipment of brick-yards, tile works, and establishments engaged in the manufacture of lime and cement and other basic building materials; finally the adoption of measures to increase the available supply of

Safe Practice at Blast Furnaces and Its Development-V.

By Frederick H. Willcox

In its efforts to increase safety in the metallurgical industries, the Bureau of Mines, Washington, D.C., has been studying the causes of accidents at blast furnace plants also methods for their prevention. This article describes the known dangers and makes suggestion of means whereby the risk of accident may be lessened or, better still, wholly avoided.

PIPPE FITTERS AND TUYERE GANG

Do not go up on the bustle pipe or stack platforms until you have notified the blower, keeper, or stove tender. When going above the bustle pipe it is safest to have a watcher. Before repairing sprays on dust catchers or on

Try them frequently by testing the steam line to the main for gas, and, if the line is plugged, clean it. Try the lines from the water and also from the steam supply for delivery; keep them drained to prevent freezing, and be sure the valves are not stuck. Do not let the water collect in the water-seal valves.

Successful and safe furnace operation depends in part upon the cooling-water system being kept in proper condition. Careful testing of tuyeres, coolers, plates, regularity in flushing the mud and sediment out, and regular inspection of the strainers, will do away with much of the disagreeable, difficult, and, at times, dangerous work caused by chilled or slipping furnaces, "messes," and bursting tuyeres due to water leaks.

Bricklayers

Inspect a scaffold before going up on it, and do not let your helpers or laborers go up unless you are satisfied that the scaffold is safe; many of them probably do not know whether it is safe or not, and must rely upon your judgement. In piling brick on a scaffold be careful not to overload it. Don't permit your helpers to drop the bricks on the flooring; make them set the bricks down carefully, and don't let buckets of clay or loads of bricks down heavily. Avoid overloading the hoist buckets, so that the material can not fall off; use safety hooks for hoisting buckets and pails. Don't throw brickbats down promiscuously when you are on a repair job; rope off a danger place, and place a danger sign to warn the men. Be careful not to leave your tools or bricks where they can be easily dislodged and fall, whether there are men below or not.

skips, skip-pit siphons, steam, air, or oil lines on top of the furnace, or sprays on the furnace jacket, notify the furnace foreman as it may be necessary to stop charging or to check the furnace.

Leaking steam, where the men have to work, is always annoying and is frequently a menace on account of the noise and the mist, and the possibility of scalds. You can do much to prevent the danger from this cause by promptly attending to the leaks. Warn other men of the danger of attempting to stop steam leaks on pipes under pressure by tightening flanges.

A blast-furnace plant is different from other plants in that, if an emergency requires a quick shutdown, the operation may be very hazardous, unless everyone knows what to do and does the work assigned to him promptly and accurately. Make it your first duty to learn the layout of the water and the steam lines leading to the gas mains, and the water lines leading to the water-seal valves. It is up to you to see that these lines are always in working order.

and if you get a bruise, abrasion, laceration report it at once.

Carpenters

It is your duty to use sufficient and strong enough lumber to make every scaffold, staging, railing, gangway, and ladder safe. The men may not know whether they are safe or unsafe; but whether they are competent or incompetent to judge, you can not evade responsibility for unsafe construction. Temporary ladders, runways, and other wooden constructions not intended for permanent use often are used when they have become unsafe. Make it your duty to condemn any unsafe equipment of this kind and to promptly remove temporary scaffolds or ladders when the need for them has passed.

Avoid leaving lumber with projecting nails about the plant, and hammer flat or remove all projecting nails that you notice on scrap lumber or lumber used in construction. (See Figs. 38 and 39). In laying planks for temporary floors, walks, or runways place the ends so that men in stepping on them will not tip the planks up.

Most of the accidents that happen to men doing carpenter work are caused by



FIG. 38. WORKMAN THROWS DOWN BOARD WITH NAILS IN IT.



FIG. 39. RESULT OF LEAVING BOARD LYING ABOUT WITH NAILS IN IT.

their hitting themselves with hammers and hatchets, from saws slipping, and in handling lumber. In working on lumber piles watch that you do not fall. In handling rough, heavy, or splintered lumber be careful not to drop it on your

Before going into inclosed places where gas has been used or contained satisfy yourself that the gas valves are tightly shut. Remember that in such places there is always an odor of gas unless ventilation is very ample and pronounced. It is sometimes necessary to go into these places, and although you may feel assured that there is no gas leak, come out at once if you begin to feel dizzy or ill. Gas may come from old brickwork, flue dust, bulkheads, or wet surfaces in amount sufficient to overcome you, and when ventilation is difficult the slightest odor of gas is a warning for you to exercise the greatest caution. Always wear a belt and life line and a breathing apparatus where ventilation is weak or lacking and there is reason to expect gas. Use electric lights when working inside gas mains; torches make the air unfit to breathe. Use goggles when you are cutting brick,

hands or foot or lacerate your hands. Be watchful and careful in the use of hand tools, and observe danger signs and the directions and warnings of foremen acquainted with the dangers at the different parts of the plant. By so do-



FIG. 40. SAFE WAY TO OPEN A SWITCH. USE ONE HAND AND KEEP OTHER BEHIND BACK.

ing a large proportion of the injuries commonly encountered will be avoided.

Electricians

The insulation on electric wires and on tools and rubber gloves can not be depended on to prevent shock, as the insulation may not be in good condition. Do not work on live circuits unless absolutely necessary, and if necessary and you are in doubt as to the voltage of the circuit, consult the foreman and obtain his permission.

Try to observe the following precautions: Use only one hand if possible (Figs. 40 and 43); work on only one wire at a time and insulate it before starting on the next one; insulate parts of opposite polarity within reach of tools; do not touch electric conductors when you are standing on iron plates, structural iron, wet ground, or pavement—get a dry board or rubber mat to stand on; use tools with the handles adequately wound with tape, and wear rubber gloves without cracks or holes. Take the same precautions with supposedly dead circuits, as there is always a chance of such circuits being crossed with a live circuit. Low-voltage system, telephone wires, and signal wires may similarly be crossed with high-voltage lines.

When power has been cut off by opening a switch place a danger sign bearing your name on the switch and lock it open. Do not remove the sign and lock unless the work is completed, everybody and everything clear of the circuit, and no one in a position to be

injured by the machinery starting up. Do not attach wire or cord for lights to iron pipes or structural parts. Neglect of this precaution may lead to charging of equipment or parts so that a man may receive a shock when least expected. Make frequent inspection of flexible cord for hand lights, portable clusters, or electric drills. The various crews frequently handle them when standing on wet places where, should the insulation be defective, a serious burn or shock might result.

Remove all dead circuits not likely to be used. Avoid installing temporary wires in a slipshod manner. Do not let inexperienced men handle electrical equipment, and do not set bad examples of careless familiarity with electrical equipment for inexperienced men to follow. Always attend immediately to an electric burn. Such burns are often misleading; a third-degree burn which may not be immediately painful may later result in gangrene.

Cranemen

Never carry a load over a workman's head. If men are working in the path of a load, run the trolley out to avoid them, or give them warning. Before moving a crane be sure that no one is in a position to be injured. Open the main switch before leaving the cab, and do not go or allow another to go on top of the crane runaway without opening the main-line switch and attaching to the switch a notice bearing his name. If the switch is found open and no notice on it, notify the foreman instead of shutting it yourself; there may be a reason for its being open.

Do not hoist without a signal when men are hooking on or slinging material. If possible be sure that their hands are not inside the hook or sling. Place the trolley directly over the load to avoid swinging it against the workmen. In hoisting heavy loads test the brake when the load is a few inches clear of the floor.

After a repair job is finished go over the crane carefully and pick up any tools, bolts, or parts left behind. Watch for loose parts; see that the brakes, warning bells, and switches work properly and report at once insecure or dangerous parts or places. Don't leave chains, hooks, or buckets hanging at heights that do not clear a man's head.

Notes on First Aid

In plants where the continual presence of a doctor or nurse is not feasible it is advisable to have at least one emergency first-aid box. These boxes are furnished by various manufacturers and associations and contain materials designed or recommended by advisory boards of physicians and by the American National Red Cross. They are admirably adapted for use at isolated plants and primarily are for the prevention of infection. A first-aid box in the charge of the chemist, storekeeper, or watchman will encourage the workmen to form the habit of seeking

immediate first-aid treatment for slight injuries. Such treatment, if correctly performed, may prevent infection or illness, but further treatment should be by a physician.

When a man is so badly injured that he needs immediate relief before a physician can arrive or before he can be taken to the first-aid room it is essential that some one with a knowledge of first-aid should assume charge, preferably the foreman, first-aid man, member of safety committee, or ranking employee and direct the work of caring for the injured man until the doctor arrives.

Transportation of Injured

Do not move an injured person or move any part of his body until you are sure of the nature of the injury. If the injured man is unable to walk use the greatest care in placing him on the stretcher. Stretchers are now so universally available at plants that mention of other means of carrying men should be unnecessary; however, familiarity with methods of handling injured men is essential.

Eye Injuries

Any object in the eye that irritates the lid or eyeball probably makes a cut which may be infected just as easily as a cut on the hand or foot, and more so if a toothpick, match, knife, or handkerchief is used to remove the object. Moreover, infection of a wound in the eye is a very serious matter, because the

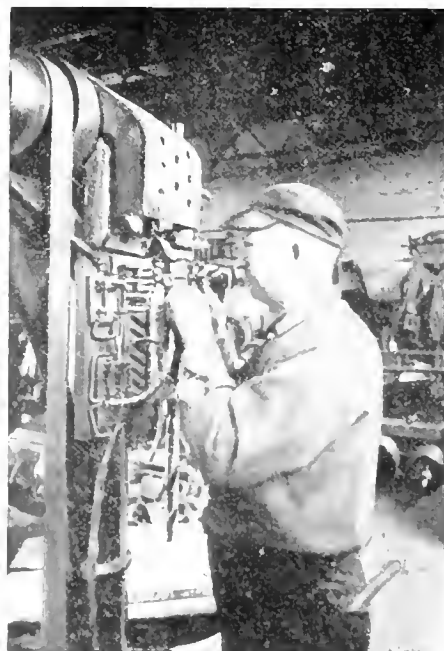

FIG. 41. ELECTRICIAN REPAIRING WIRES WITH SWITCH IN: A DANGEROUS PRACTICE.

eye is the most delicate external organ of the body. If any injury to the eye is neglected or wrongly treated, not only may the eye become inflamed, involving loss of time, but the sight may be lost. If you get something in your eye, do not try to remove it from the eye at your

working place; go to the first-aid station and have your eye examined at once. If the object can not be removed by cotton rolled on the end of a match or toothpick or by a loop of sterile horsehair, it is probably imbedded in the eyeball or eyelid, and the injury



FIG. 42. RESULT OF REPAIRING WIRE WITH SWITCHES IN. SHORT CIRCUIT BURNS ELECTRICIAN.

should be examined by a physician immediately.

Cuts, Lacerations, and Punctures

Whenever the skin has been cut accidentally, it is safe to assume that germs have been introduced, because tools, clothing, or other material, the dust in the air, or the skin itself may carry disease germs. Every wound should be primarily looked upon as infected and receive immediate attention. A fresh cut should not be washed, even by the first-aid man; leave that for the physician. Unsterilized water is dangerous, for it may contain infectious germs. For the same reason waste,

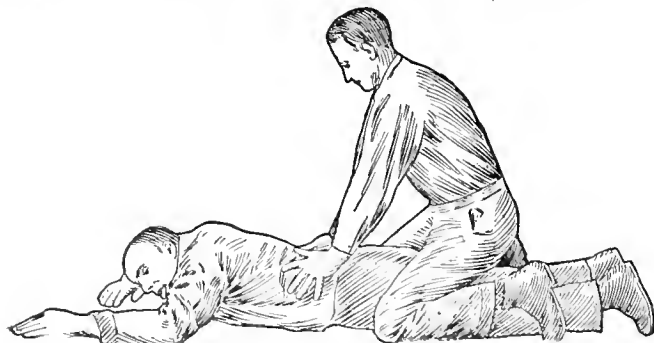

FIG. 44. SCHAEFER METHOD OF ARTIFICIAL RESPIRATION—EXPIRATION.

cobwebs, tobacco, or dust should not be put on a wound, nor should the open wound be touched with the fingers.

If a fellow workman gets hurt and the wound bleeds profusely, or in spurts, apply a tourniquet or constrictor and notify the first-aid man. Immediate

first aid by fellow employees is imperative in such cases, as the man may bleed to death before the first-aid man can arrive. A belt, suspender, handkerchief, rope, or any immediately available material that can be tied with a knot and twisted will do for a tourniquet. The man should be made to lie down and the injured part be kept elevated as high as possible by some one. If a limb is crushed or badly mangled, the tourniquet should be placed above the knee or elbow, near the crotch or arm pit, and twisted until just enough pressure is obtained to stop the blood. Every 20 or 30 minutes the tourniquet should be loosened a little; if bleeding recommences, it should be tightened again. If the circulation is stopped completely for upwards of three hours gangrene may develop. Many severely bleeding wounds may be stopped simply by pressure in the wound with a clean bandage.

Puncture wounds, such as are caused by nails, slivers, and small sharp objects are perhaps the most dangerous of all small wounds. Such cuts are always larger on the inside than on the outside on account of the elasticity of the skin, and the danger of infection is greater because the puncture closes, little bleeding occurs, and there is less chance of any dirt and germs that may have gotten into the wound being flushed out by the flow of blood. Puncture wounds of the foot, and the palm of the hand, the thumb, and the little finger are especially dangerous.

Burns

A burn is not readily infected when first inflicted unless it has been broken open accidentally or by careless or improper handling. A burn should not be washed by anyone except the physician. For small burns pieric-acid gauze or sterile gauze with vaseline spread on it, placed over the burn and fastened with a roll bandage, is efficacious. The use of carron oil, which is a mixture of linseed oil and lime water, is not recommended. Soda and sterilized water may be used, but is not as soothing to burns as pieric acid.

sary to cut away part of the clothing, such as a sleeve or trouser leg. In case medical or hospital attention is not immediately available, the entire burned area should be covered with pieric-acid gauze or vaseline-covered gauze. If a hospital is near, the clothing may be



FIG. 43. SAFE WAY TO REPAIR A WIRE; SWITCHES OUT.

saturated with a soda and water solution (one-fourth pound soda in a half gallon of clean water). After such treatment, the injured person should be wrapped closely in a blanket.

All burns should be reported immediately to the foreman or first-aid man. Sometimes a second or third degree burn—that is, one in which the inner and outer skin, or skin and flesh beneath, are destroyed—may not, although a serious burn, be immediately painful, but later may lead to gangrene.

Fractures

For the purposes of first-aid, fractures may be classified as "simple,"

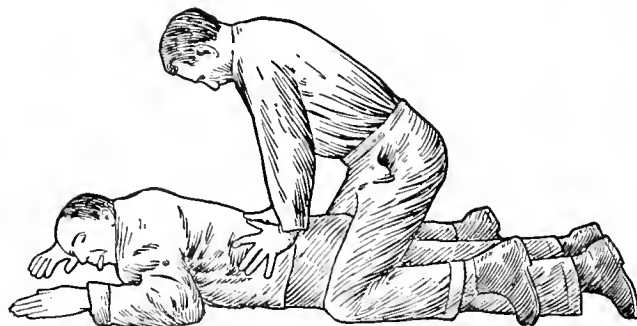

FIG. 45. SCHAEFER METHOD OF ARTIFICIAL RESPIRATION—INSPIRATION.

When a large burn is caused by clothing ignited from hot metal or cinder, or by electric flashes, steam, or boiling water, it is better not to remove any but the outer clothing. The injured man should be handled as little and as carefully as possible. It may be neces-

sary when the broken bone does not come through the skin, and "compound," when the broken bone sticks through the skin. Unless a broken limb is handled carefully a simple fracture may be converted into a compound fracture; therefore, a man with a fracture should

not be moved until a splint has been applied. A compound fracture requires a longer time for recovery than a simple fracture.

A splint is simply a light stick or piece of wood for keeping the injured part in a fixed position by means of bandages. A broken arm or leg can be placed in a straight position, and if no splint material is available, a coat may be rolled from each side toward the center over the sleeves, placed about the broken limb, and tied there. An injured arm may then be tied to the body or a broken leg to the uninjured leg.

In case of a broken back, neck, or severe crushing and internal injury a patient should not be lifted until a physician comes. Unnecessary handling is harmful, causes needless suffering, and as a physician is generally immediately available at furnace plants, first-aid in such cases is, as a rule, of questionable value. The patient may be kept flat on his back and covered with a warm blanket.

Blows on the Head or Abdomen

When a man receives a blow on the head or abdomen, first-aid is not usually possible. Avoid rough handling, loosen the clothing, do not give liquid stimulant, and call a physician at once. Don't let the patient go home alone. After receiving a severe blow on the head men have continued work, or stopped work for the day, and then suddenly became seriously ill or died. Similar developments are possible after a heavy blow on the abdomen.

Bruises and Strains

Such injuries as bruises and strains should always have the attention of a physician rather than first-aid only, for although the injury may at the outset seem very slight, it may develop into a deep-seated injury with permanent total or partial disability.

Asphyxiation or Shock

To remove a victim from contact with an electric circuit, cut the current off if there is a switch handy. If not, roll or push the man's body from the circuit with a dry piece of wood or wrap your hands in a dry cloth stand on dry wood, grasp his clothing and lift his body from the wire, or place a loop of dry cloth or rope over the man's head or feet and jerk him from the wire.

In case a man has been asphyxiated or "gassed," or has received an electric shock, carry him into the open air, send for a doctor, and then proceed as follows: Feel with your finger in his mouth and throat and remove any false teeth, tobacco, etc. Lay him face downward, with one arm extended out straight beyond his head. Place his other arm under his head, and turn his face to one side, so that mouth and nose are free for breathing. Have someone draw his tongue forward. Put a folded jumper or coat under the lower part of his chest if he is thin. Straddle him on your knees, facing his head (see Fig.

44), with your knees a little below his hips; then with fingers outstretched place your hands at the lower part of his ribs with your thumbs nearly joining.

Hold your arms straight and rigid, swing forward slowly so that the weight of your body is gradually brought to bear on the subject's body; then swing back, removing the pressure, but keep your hands in place; repeat 16 to 20 times every minute. (See Figs. 44 and 45). If you have not a watch, follow the rate of your own deep breathing. Keep it up for 3 hours unless natural breathing is resumed. Keep the man warm and do not try to give liquid stimulant until he is conscious and able to talk and drink. Do not hold ammonia bottles under his nose or mouth. It is important that every foreman and every member of a safety committee in the plant should understand this method of resuscitation.



MINERAL RESOURCES OF BRITISH EMPIRE

A PAPER was read on December 11, 1916, by Dr. C. Gilbert Cullis, Professor of Economic Mineralogy in the Imperial College of Science and Technology, on "The Mineral Resources of the British Empire with regard to the Production of the Non-Ferrous Industrial Metals." The particular metals dealt with were: Copper, lead, zinc, tin, and aluminum. The object was to demonstrate the Imperial position with regard to each of these, and to show in respect of which of them the Empire was, on the one hand, self-sufficing, or, on the other, dependent upon foreign countries. In the latter case, the extent of the dependence was indicated, and methods suggested by which it might be diminished. The situation with regard to four out of the five metals was shown to be wanting in independence and scarcity, and the necessity for a full investigation of the British mine and smelter-production was insisted upon.

With regard to copper, not only were the ore-resources, as at present exploited, deficient, but the smelting facilities also were seriously inadequate for the Empire's metal requirements. The production both of ores and metal could be substantially increased by suitable organization and administration.

Lead and zinc ores, raised in British territory, had in the past been exported on a large scale to foreign countries, notably Germany and Belgium, for metal recovery, with the result that the Empire had been placed in an anomalous position of dependence which ought never to have arisen. The shortage of zinc, in the early days of the war, and the consequent jeopardising of supplies of cartridge-brass were referred to. The mine-production of lead and zinc was more than sufficient for the Empire's requirements, but the smelting facilities were lamentably deficient, especially in the case of zinc. It was urged that all

the lead and zinc concentrates of Broken Hill should in future be smelted within the Empire.

In the case of aluminum, while the actual bauxite resources of the Empire were so small that dependence had to be placed upon the French or American deposits—which were being more and more utilised in their countries of origin—large potential supplies, in the form of laterite, had a very wide distribution in the tropical colonies, but were almost untouched and untried. The systematic examination of these and other potential sources of aluminum, with a view to their utilisation, should have serious consideration.

The only metal with regard to which our position was really strong was tin. The British mine-production of tin in 1912 was 66,000 metric tons out of a world's total of 125,000, and its smelter-production 85,000. Estimating the consumption at 32,500 tons, there remained 53,000 tons for export. Now that the German market for Bolivian tin ore was closed, an opportunity had arisen of securing the whole of the Bolivian output for British smelting.

In a series of general conclusions, a plea was put forward for the elimination of wasteful methods in ore and metal recovery, for the fuller utilisation of by-products from ores, and for the adoption of large scale operations of high engineering efficiency by which capital and labour might be advantageously used. The wide-spread export of raw or partially smelted materials, produced within the Empire, to foreign countries for the recovery of the finished products was condemned, and the promotion of industries making for independence as regards essential products advocated.

The expediting of geological and mineral surveys of all British territory, and the organization of advance investigations with the object of improving current processes, or of discovering new ones by which geological materials hitherto unexploitable might be made productive, were urged.

The development of the mineral resources of the Empire had taken place in the past without any constructive Imperial policy: it had lacked co-ordination and control and was in need of scientific and business-like administration, and the suggestion that a Government Department of Minerals and Metals should be established to foster and safeguard mineral resources and to promote the welfare of related industries was strongly supported. If formed and properly conducted, such a department should do much to give security and order to what was now full of danger and disorder.



Generally speaking, each metal and alloy has a particular temperature at which it possesses maximum fluidity, this temperature usually being only slightly higher than the fusing point. Metal should always be poured as soon as ready, as it deteriorates if held too long in a molten condition.

PROGRESS IN NEW EQUIPMENT

A Record of New and Improved Machinery and Accessories for the Machine, Pattern, Boiler and Blacksmith Shops, Planing Mill, Foundry and Power Plant

GEAR DRIVE PIPE THREADING MACHINE

THE illustration shows a pipe threading machine having a capacity of from 2½ in. to 8 in., a feature of the machine being an all gear drive from single belt pulley, by means of which 8 changes of speed are obtained. The gear box is located at the back of the headstock and the belt pulley drives through a friction clutch controlled by the long hand lever in front of the chuck. The controlling levers for the different speeds are arranged in front of the headstock with speed plates indicating the proper position for the various sizes of pipe.

The die head is of the sliding type, with conveniently arranged handles and cam lever, and is equipped with Peerless die mechanism. The die-head can be quickly removed so as to allow very short ends or lengths of pipe to be cut off, the cutting-off tool and steady slides being on the other side of the carriage from the die-head. Renewable hardened steel facings support the pipe in the steady slides, that opposite the tool having an extra large face. The cutting-off slide is attached to one of the steady slides so that the tool is supported near the cutting edge; the reaming tool is held in a tool post on the cut-off slide.

Duplicate chucks are employed on each end of the spindle, with three independent jaws, graduated on the face for pipe sizes, the jaws on the rear chuck having special flange grippers for use in making up flange fittings. The front chuck is bolted direct to driving gear. All gears in speed box are of steel running in oil.

When equipped with motor drive, a 5 horse-power constant speed motor is used, with silent chain drive to clutch; reversing switch is fitted for cutting left hand threads. The lathe type bed is of ample strength and has a closed bottom forming drip pan, arranged at an angle to drain off compound. Ample provision is made for lubrication of all wearing parts, chain oiling bearings being provided on the spindle, and splash lubrication in gear box.

Regular equipment is complete with oil pump and connections, nine sets of dies, die cabinet and tool tray, countershaft, wrenches and extra cutting-off tool. This machine is built by John H. Hall & Sons, Brantford, Ont., weighs 7,400 lbs., and occupies a floor space 3 ft. x 9 ft.

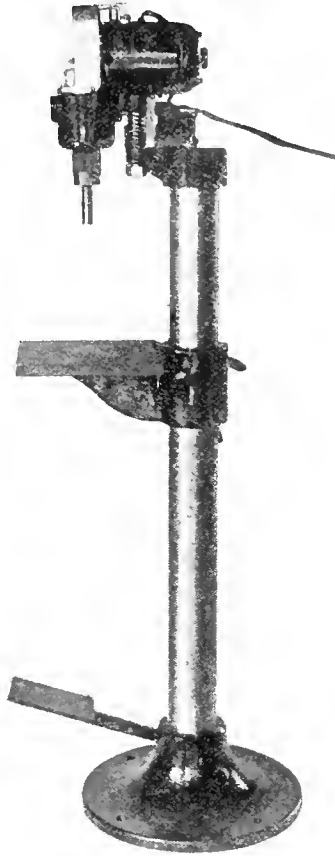

ELECTRIC RIVETER FOR SHELL BASE PLATES.

ELECTRIC RIVETER FOR SHELL BASE PLATES

THE adaptation of electric power to the work of riveting shell base plates

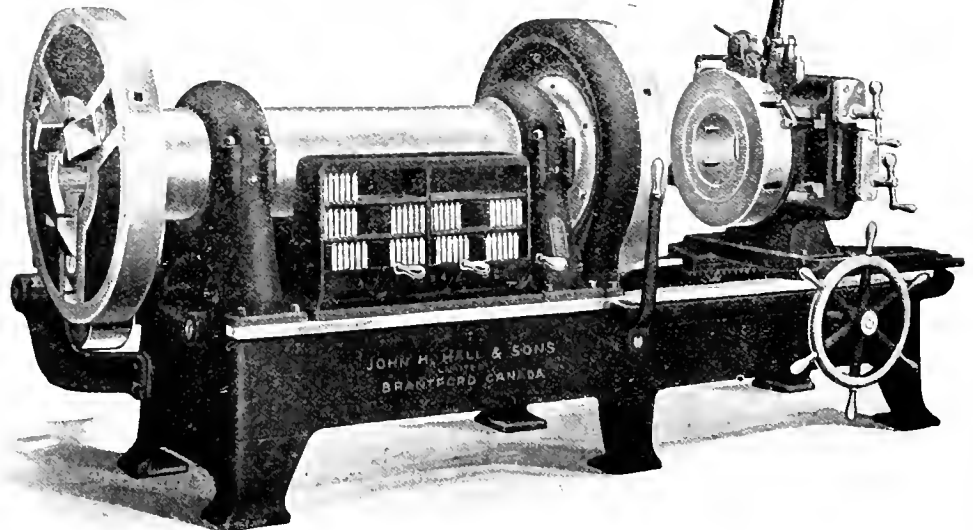

8-IN. PIPE-THREADING MACHINE WITH GEAR BOX DRIVE.

has been successfully accomplished by the machine shown in the accompanying engraving. The operating mechanism consists of a standard type of electric hammer which has proven highly efficient in all classes of work to which power hammers are adapted.

The principle member of the device is the electric motor, which is specially designed and constructed for this particular service, and is carried in a spring base pedestal, mounted on the top of the column. The striking mechanism and tool guiding device is of standard design, while an adjustable work table is carried on the turned column, the height of which is ample to allow of using any fixtures for supporting or revolving the two sizes of shells operated on, viz. 4.5 in. and 18 pdr.

Pedal control is provided for starting and stopping the hammer, which strikes 1,800 blows per min. with a force of forty pounds per blow, the net weight of the machine being 250 lbs.

This riveter as well as the complete line of regular electric hammers is marketed by R. E. T. Pringle, Ltd., Toronto.



SQUARE HOLE DRILLING DEVICE

A UNIQUE addition to existing machine shop accessory tools has been made in the production of the Radbere Head for drilling square holes. This device makes the production of square holes a commercial proposition, high quality of work, low cost of operation, and wide field of application being outstanding features of the apparatus. In drilling square holes, the flanged housing, or main guiding member, as it is termed, is clamped

to the column of a milling machine, and a drill of the required size is set in the head, after which the work is done as in ordinary drilling. See Figs. 1, 2 and 3.

The cutting of the hole is performed by a special drill made in two types, which produce either full square holes with sharp corners, or with filleted corners having a radius one-eighth the size of hole. Several sizes of drill of either

ink sharp corners a similar drill is used, see Fig. 4, the shank F of the drill being of such a size that the centre O of the rounded corner coincides with one of the cutting edges. As the shank revolves in the guide bushing D, the three cutting edges are led around in straight lines, while the edge referred to acts as a pivot at each corner in succession due to it being on the centre of the circular corner of the shank. Four points of

The spindles are carried in counter-weighted saddles, adjustable vertically, on two upright columns carried on the wings of the bed. These spindles are driven through worm and worm wheel, both completely encaused for oil bath lub-

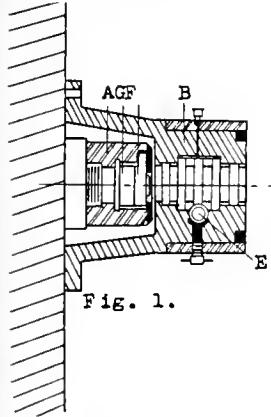

Fig. 1.

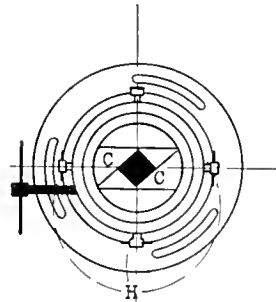

FIG. 2.

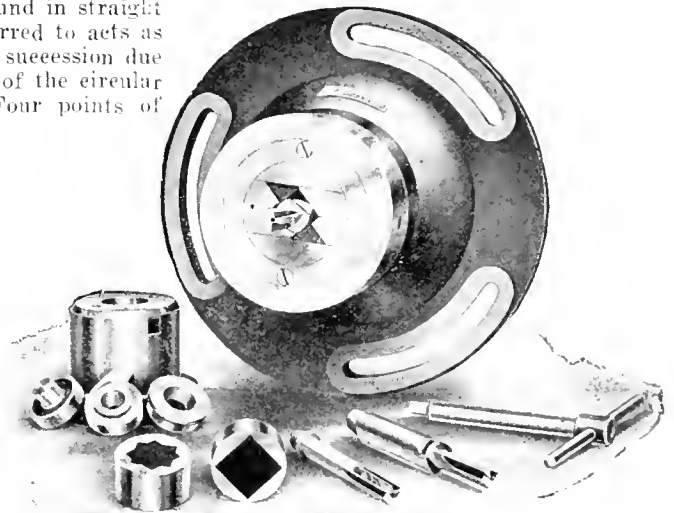

FIG. 3.

type can be used in the one head, the depth of hole possible being great enough for nearly all commercial requirements. In addition, the device will drill blind holes with a perfectly flat bottom; grinding is done on the end only, giving long life to the drill, and constant accuracy to the product.

support are also obtained at all times with this drill, preventing any slipping or sliding away from the fixed line of the work.

A special grinding attachment or vise can be supplied for facilitating the accurate grinding of the drills on ordinary grinding or milling machines.

This device is being placed on the market by Aikenhead Hardware Ltd., Toronto.

rication, control of the drive to each spindle being had through a clutch on the inner end of the worm wheel sleeve; the clutch lever is arranged in front of the saddle in a position convenient to the operator. Spindles are bored in the nose to accommodate a 3 in. dia. straight plug, and are arranged to drive cutters by means of 1 1/4 in. wide face keys; they are large enough, however, to allow of being bored No. 6 Morse taper, and having a hole through for cutter retaining bolt.

Retangular or oblong holes are pro-

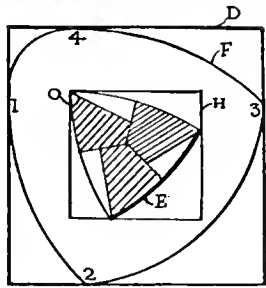

Fig. 4

SPECIAL DUPLEX MILLING MACHINE

THE machine illustrated in the accompanying engraving is interesting in that the design provides a greater degree of power control than it has hitherto been customary to provide in tools of this type. It is a recent production of the Newton Machine Tool Works, Philadelphia.

The counterweighted spindle saddles have provision for simultaneous or independent vertical adjustment with reversing vertical feed and reversing fast power traverse. They have narrow guide, alignment control bearings on the uprights, and provision for bolting rigidly at any desired height. The uprights, also, have independent and simultaneous adjustment, with reversing fast power traverse on the wings and provision for

duced by either feeding the stock side ways or drilling overlapping holes.

The principle on which the filleted hole is produced is shown in diagram, Fig. 5. The curved lines show the outline of the drill body which revolves in a square guide bushing the same size

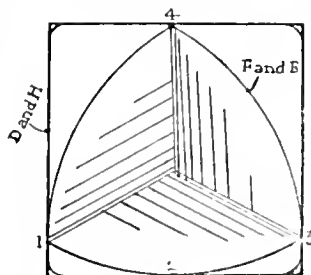
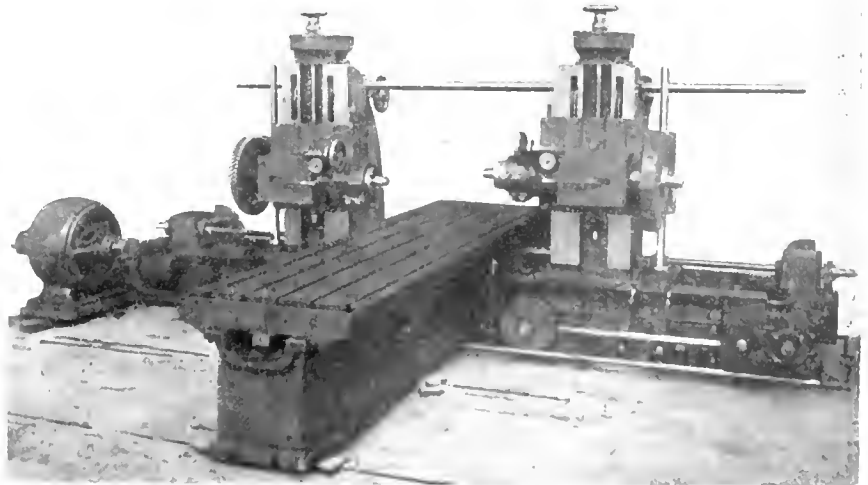

Fig. 5

as the hole. The four points of contact are present at any stage of the revolution, point 2 changing its position to the other curved lines in rotation. In drill-



DUPLEX MILLING MACHINE WITH SPECIAL POWER CONTROL, BRACED UPRIGHTS AND SQUARE GIBBED TABLE.

bolting rigidly in any desired position. All vertical adjusting screws have bearings at each end to insure their operation under tension.

The work table has square lock bearings on the base with overlapping gibs and has angular rack and worm pinion drive, hand adjustment, 9 changes of feed through sliding gear feed box, and also has reversing rapid traverse by power.

The machine is designed to carry cutters up to 16 in. dia. when working on cast iron, is provided with suitable scales for accurately adjusting the spindle sleeve horizontally and the saddles ver-

search bureaus, with properly equipped laboratories, be established in industrial centres in Canada, in order to assist in the solution of problems which present themselves to the manufacturers, received the support of the Council, and plans were laid for developing in Canada a body of men trained in science, and its application to industry.

Collecting Data

There was further considered at the recent meeting the various lines of work which the Council might undertake, also some forty projects which had been submitted to it. It will, within the next

manufacturing industries the Council proposes the establishment of industrial research bureaux at such centres as Toronto, Montreal and Winnipeg. These would be supplied with a complete set of technical and trade journals, would have a competent technical staff and properly equipped laboratories. In co-operation with the Provincial Government and other bodies these bureaux would be able to solve the problems which arise in their factories.

The Council has decided to examine carefully a number of the specific projects which have been submitted to it and to recommend that certain of them be taken up at once. For instance, it decided to recommend that investigations be continued with a view to utilizing the lignite to be found in Saskatchewan. Lignite in its crude state is an inferior fuel which possesses a relatively low heating power and which moreover will not stand shipment or storage. It is, therefore, of comparatively little value for domestic or manufacturing purposes. The Council, however, believes that from lignite can be produced two grades of high-class briquetted fuel, one similar to anthracite coal and the other resembling soft coal in general character, and that at the same time certain very valuable by-products may be obtained.

The Council has taken cognizance of the fact that the forests of Eastern Canada have been seriously depleted and are rapidly deteriorating in character. It has recommended that investigations be made by the Forestry Branch of the Department of the Interior with a view to ascertaining the best methods for preserving these forests and making them a permanent source of wealth to the people of the Dominion. In European countries the forests have been improved in character by the application of scientific knowledge and have been converted into assets of enormous value, yielding large revenues to the Government or their owners, and, at the same time, retaining unimpaired their capital value.

The Council has before it other important projects, but requires to examine them further before taking action with reference to them.

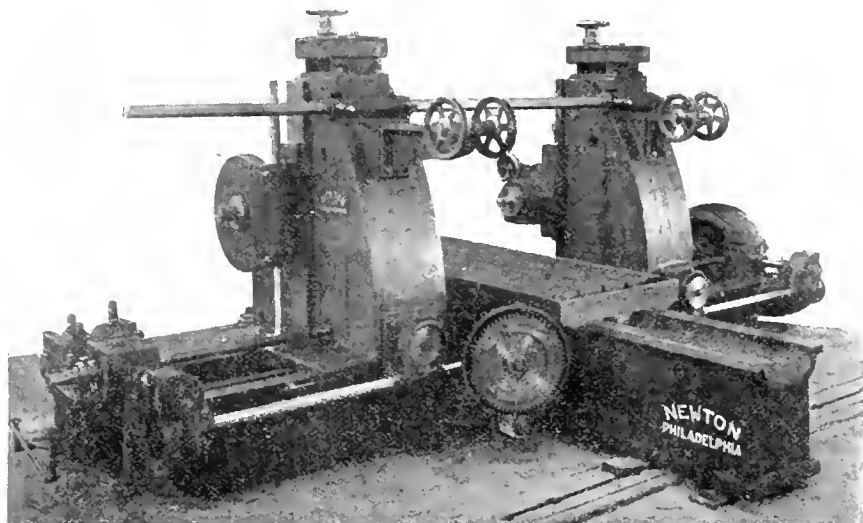

REAR VIEW OF DUPLEX MILLING MACHINE SHOWING ANGULAR DRIVE TO WORK TABLE.

tically, and both spindles can rotate independently or in unison.

A 20 horse-power Fort Wayne motor is employed for driving purposes, operating at 300 to 900 revs. per min., and giving spindle speeds of from 5.4 to 55.2 revs. per min.

The maximum distance between ends of spindles is 90 in., minimum 12 in.; distance, centre of spindle to table, max., 25 in., min., 2 in.; work table, 14 ft. x 42 in.; max. length, milled, 12 ft. 6 in.; dia. of spindle in worm wheel sleeve, 1 in.; dia. of spindle flange, 9 in.



TO DEVELOP RESOURCES OF THE DOMINION

EXPERIMENTS having for their object the utilization of the vast quantities of lignite to be found in Western Canada, for the production of fuel for industrial and domestic purposes, have been recommended by the Council for Scientific and Industrial Research, which has been in session at Ottawa. Investigation by the Forestry Branch of the Department of the Interior, with a view to devising methods by which the threatened destruction of the forest resources of Eastern Canada will be prevented and the forests will be made a permanent source of wealth to the Dominion, are also advocated. A proposal that industrial re-

search bureaus, with properly equipped laboratories, be established in industrial centres in Canada, in order to assist in the solution of problems which present themselves to the manufacturers, received the support of the Council, and plans were laid for developing in Canada a body of men trained in science, and its application to industry.

The Council will recommend the foundation of twenty or more scholarships or fellowships in Canadian universities and technical schools to be given to men who have completed their regular courses of study and have displayed a special aptitude for scientific research. The men to whom these scholarships or fellowships are awarded will be enabled to pursue a course of advanced work at college. Arrangements will also be made whereby students will be placed, after graduation, in the larger manufacturing establishments in Canada, to continue their training under conditions of actual commercial practice.

Body of Practical Scientists

By these measures the Council hopes to build up in the Dominion a body of practical scientists similar to that which has aided so greatly in industrial development in Germany in recent years. To furnish immediate direct assistance to

Purely Personal.—The commercial traveler met Sandy, the canny one, emerging from the post office.

"Ah! Sandy!" cried the traveler, "it is good to see a prosperous farmer as yourself—not forgetful of his country. You have been in the post office to purchase war bonds?"

"Nay," said Sandy easily.

"Oh! Then, perhaps you have not a little money in the savings bank that it may help the country?"

"Nay."

"Well," said the traveler as a last resort, "I suppose that you have bought a postal order to send to some poor acquaintance?"

"Nay, I've been in to fill my fountain pen."

The MacLean Publishing Company

LIMITED

(ESTABLISHED 1888)

JOHN BAYNE MACLEAN - - - - - President
 H. T. HUNTER - - - - - Vice-President
 H. V. TYRRELL - - - - - General Manager

PUBLISHERS OF

CANADIAN MACHINERY AND MANUFACTURING NEWS

A weekly newspaper devoted to the machinery and manufacturing interests.

PETER RAIN, M.E., Editor. R. G. NEWTON, Manager.

Associate Editors,

A. G. WEBSTER, J. M. WILSON, J. H. RODGERS.

Office of Publication, 143-153 University Avenue, Toronto, Ont.

Vol. XVII. MARCH 1, 1917 No 9.

LAST MONTH'S HAPPENINGS—THIS MONTH'S SACRIFICE AND SERVICE

THE month just closed cannot be said to have been uninteresting, lacking as it did in its twenty-eight-day span neither thrilling episode in the war activities, nor drastic legislation towards larger service and greater sacrifice in swaying the war fortunes. Germany's advised submarine propaganda against merchant vessels trading to British ports, although to a very great extent successfully combated, has nevertheless been far from barren of results, much tonnage, and not a little of it of commercially superior quality, and all of it ill-spiced, has been ruthlessly sunk, together with valuable cargoes carried. The loss of life, fortunately, has been light, comparatively.

The big event of the month was, of course, the speech of David Lloyd-George, Britain's Prime Minister, in the House of Commons on February 23, to the variety detail requirement of which the nation as such was asked to submit patriotically. Neither from a superficial glance at existing conditions, nor from a deep study of the portent of events leading up to his declarations, can other than the conclusion be come to that the welfare of the people of the Motherland and the effectiveness of our arms in conjunction with those of our Allies are being menaced in most threatening degree. Vessel tonnage of commercial rating has been, all through the War, disappearing from the Register, and during the past month has been doing so at a much accelerated pace. Much of that now available—as has been the case since hostilities commenced, is a prime essential of troop, munitions and general supply transportation, and at this writing may be reckoned as more than ever of paramount importance. The decision then to put into immediate effect import restrictions of the most drastic nature, while somewhat of a shock because of their comprehensiveness, has occasioned less surprise and resentment than might have been expected, not only among Britishers themselves, but among those exporters in other countries, against whom specific enactments will exert considerable economic pressure. A list of restricted imports appears in another section of this issue.

The presence of our Prime Minister, Sir Robert Borden, in the distinguished strangers' gallery during the greater part of Lloyd-George's speech, and the reference in the latter to the conference between Britain's Colonial Secretary and Canada's Premier preceding the speech, are of more than passing interest, because of Sir Robert's statement of expressed readiness on behalf of this Dominion to sacrifice our trade share to minimize the tonnage lack emergency. That Canada is behind its Premier and is prepared to go all the way in the path he has mapped out, there is not the shadow of doubt.

Indication has already been given that Germany's submarine activity is being to a large extent combated, and in more than one sense this is true. It is a well-known fact that notwithstanding grievous losses of vessels—large and small, of valuable commercial tonnage, the percentage of ships destroyed to those entering and leaving British ports is relatively small. In this respect the measures taken to offset Germany's ruthlessness may be said to be achieving considerable degree success. Even a low percentage or gradual vessel loss is, however, neither meantime healthful nor comforting, nor will its ultimate outcome—be the war of long or short future duration—lead to anything approaching British pre-war sea-borne trade ascendancy. Merchant shipbuilding, following the outbreak of war, was for many months at a standstill on Britain's river shores, so to speak, same having given place to warship construction of type, service, size and quantity that only those extremely close to headquarters administration are in a position to fully appreciate and grasp. It may, however, safely be assumed that the margin now for every fighting contingency is alike stupendous and effective. Germany's submarine effectiveness has, therefore, had to be combated in another direction—that of new freight vessel construction, and in this feature Britain may be said to be protecting herself without restriction or hindrance.

This, however, does not exhaust the possibilities of procuring additional tonnage, and its myriad supplementaries, if we rightly judge the situation. Canada's co-operative effort in munitions making has been so well and fully appreciated by the responsible authorities in the Motherland, that still greater—because of a more permanent nature, opportunities are to be made available to her. In a word, shipbuilding and marine engineering in both their basic and accessory essentials are, we understand, in process of being developed in our midst by the Imperial authorities, and on a quite comprehensive scale. As a result, it may easily be assumed that the dreaded transition period from war-time to peace-time business enterprise will be wholly negligible.

It is calculated that Canada's export trade will be affected by the import restrictions announced. On the basis of last year's exports of the affected commodities, the restrictions to be applied will cause Canadian trade diminution to amount to upwards of thirty million dollars. In a purely domestic sense the effect may be beneficial inasmuch as there will be largely conserved for the home market the commodities whose importation into Britain is now prohibited. The tendency should be towards somewhat lower prices.

Available figures for the first eleven months of 1916 show that exports of a number of the now restricted articles were valued as follows: Agricultural implements, \$2,331,239; boots and shoes, \$1,585,563; clocks, \$1,115,313; photographic goods and motion picture films, \$1,968,727; leather and tanned skins and products, \$31,089,650; canned salmon, \$9,380,000; wood, timber and products, \$8,813,640; typewriters, \$2,952,546; books, music, maps, engravings and other printed matter, \$1,138,586.

BOILER TUBES.

Size.	Seamless	Lap-welded
1 in.	\$22 00
1 1/4 in.	25 00
1 1/2 in.	29 00	24 00
1 3/4 in.	30 00	22 50
2 in.	33 00	23 00
2 1/2 in.	35 50	29 50
3 in.	46 00	34 50
3 1/2 in.	41 00
3 3/4 in.	53 00	44 00
4 in.	65 00	55 00

Prices per 100 feet, Montreal and Toronto.

OILS AND COMPOUNDS.

Castor oil, per lb.	25
Royalite, per gal., hnlk.	12
Machine oil, per gal.	25 1/2
Black oil, per gal.	12 1/2
Cylinder oil, Capital	45 1/2
Cylinder oil, Acme	36 1/2
Standard cutting compound, per lb.	0 6
Lard oil, per gal.	1 45
Union thread cutting oil antiseptic	68
Acme cutting oil, antiseptic	37 1/2
Imperial quenching oil	39 1/2
Petroleum fuel oil	12

BELTING—NO. 1 OAK TANNED.

Extra heavy, single and double	30-5%
Standard	40%
Cut leather lacing, No. 1	1 50
Leather in sides	1 35

TAPES.

Chesterman Metallic, 50 ft.	\$2 00
Luffkin Metallic, 603, 50 ft.	2 00
Admiral Steel Tape, 50 ft.	2 75
Admiral Steel Tape, 100 ft.	4 45
Major Jun. Steel Tape, 50 ft.	3 50
Rival Steel Tape, 50 ft.	2 75
Rival Steel Tape, 100 ft.	4 45
Reliable Jun. Steel Tape, 50 ft.	3 50

WASTE.

White	Cents per lb.
XXX Extra	20
Peerless	20
Grand	19
Superior	19
X L C R	18
Atlas	18
X Empire	18
Ideal	17
X press	16

COLORED.

Lion	14 1/2
Standard	13
No. 1	13
Popular	11 3/4
Keen	10 1/2

WOOL PACKING.

Arrow	25
Axle	20
Anvil	15
Anchor	11

WASHED WIPERS.

Select White	12
Mixed colored	10
Dark colored	09

This list subject to trade discount for quantity.

RUBBER BELTING.

Standard	50%
Best grades	30%

ANODES.

Nickel	.50 to .54
Cobalt	1.75 to 2.00
Copper	.44 to .46
Tin	.49 to .56
Zinc	.23 to .25

Prices Per Lb.

COPPER SHEETS.

Montreal Toronto	
Bars, 1/2 to 2 in.	\$46 00 \$46 00
Plate sheets, 14 oz., 14x28 in., 14x60 m	45 00 45 00
Copper sheet, tinned, 14x60, 14 oz.	54 00 54 00
Copper sheet, planished, 14x60 base.	57 00 57 00
Braziers' in sheets, 6x4 base	46 50 46 50

BRASS.

Brass rods, base 1/2 in to 1 in rd.	0 55
Brass sheets, 8 in. wide, 20 oz.	0 60
Brass tubing, seamless	0 55
Copper tubing, seamless	0 55

PLATING SUPPLIES.

Polishing wheels, felt.	2 10
Polishing wheels, bull-neck	1 35
Emery in kegs, American can	06
Pumice, ground	04
Emery glue	15 to 20
Tripoli composition	04 to 06
Crocus composition	07 to 08
Emery composition	08 to 09
Rouge, silver	35 to 50
Rouge, powder	30 to 35

Prices Per Lb.

LEAD SHEETS.

Montreal Toronto	
Sheets, 3 lbs. sq. ft.	\$12 00 \$14 00

Sheets, 3 1/2 lbs. sq. ft.	11 75	14 00
Sheets, 4 to 6 lbs. sq. ft.	11 50	13 50
Cut sheets, 1/2c per lb. extra.		
Cut sheets to size, 1c per lb. extra.		

PLATING CHEMICALS.

Acid, boracic	\$.15
Acid, hydrochloric	.05
Acid, hydrofluoric	.14 1/2
Acid, nitric	.10
Acid, sulphuric	.05
Ammonia, aqua	.08
Ammonium carbonate	.15
Ammonium chloride	.11
Ammonium hydrosulphuret	.40
Ammonium sulphate	.07
Arsenic, white	.12
Copper, carbonate, anhy.	.25
Copper, sulphate	.17
Cobalt sulphate	.70
Iron perchloride	.20
Lead acetate	.16
Nickel ammonium sulphate	.12
Nickel carbonate	.25
Nickel sulphate	.15
Potassium carbonate	.75
Potassium sulphide (substitute)	.20
Silver chloride (per oz.)	.65
Silver nitrate (per oz.)	.55
Sodium bisulphite	.10
Sodium carbonate crystals	.65
Sodium cyanide, 127-130%	.41
Sodium hydrate	.04
Sodium hyposulphite, per 100 lbs.	5.00
Sodium phosphate	.14
Tin chloride	.60
Zinc chloride	.60
Zinc sulphate	.09

Prices Per Lb. Unless Otherwise Stated.

The General Market Condition and Tendency

THE possibility of the United States entering the war and the effect of such an eventuality on business in Canada is still the subject of considerable speculation in manufacturing circles. This contingency and the freight congestion are tending to unsettle the industrial situation. While business generally continues very good, particularly in the steel trade, production is being restricted owing to poor shipping facilities; in consequence deliveries of manufactured products are falling behind. Manufacturers are still suffering from a shortage of fuel and raw materials, while the scarcity of suitable labor is also causing much inconvenience. Assisted by improved weather conditions the railways have been able to move a larger volume of freight recently, thus relieving the congestion to some extent. It will, however, be some time before conditions are normal. The iron and steel market continues very strong and indications point to higher prices on all steel products. The principal advances this week include boiler and structural rivets, wire products, including wire nails, pressed steel spikes, and cut nails. Export demand for steel products continues heavy, but production is still being restricted, owing to the shortage of coke and pig-iron. The ingot metal markets are strong, reflecting the expectation that the United States will declare war on Germany, in which event an increase in demand for war metals would result. Copper, lead and spelter have advanced, due principally to a scarcity of spot metal in the East, resulting from the railway embargoes. The scrap metal market is strong and prices have been well maintained. The machine tool market is quiet and demand light.

Montreal, Que., Feb. 26.—The industrial situation is suffering from a lack of all classes of commodities, due to lack of transportation facilities. The wave of freight congestion has passed from the Atlantic seaboard back to the Middle West, thus reducing railroad communication to a minimum. The effects have been

all too apparent in lack of fuel, while materials for manufacturing have been so scarce that many plants have had to close down temporarily. A spell of mild weather afforded some slight relief, but only a change in basic conditions can ameliorate to any considerable degree the present unfortunate conditions.

Pig Iron

The outlook for a stronger market in pig iron seems apparent owing to the entailment in production that has resulted from the lack of raw materials. Prices on American pig are already advancing, and prospects of early relief are not encouraging. Developments now in progress may still further affect the situation.

Steel

The paralyzed condition of trade generally is probably more emphasized in the steel industry than in any other, owing to the dependency that at present is placed upon this commodity. Instead of improvement, the trade is anticipating a still more serious condition, and transportation facilities are daily becoming more demoralized, rapidly approaching a stage where a crisis appears imminent. The non-delivery of raw materials is placing the mills and furnaces in a very serious position, and shut-downs are reported daily. This results in a material decrease in production, which must naturally be transmitted to the other lines of activity, affecting not only the output of manufacturing plants, but creating a situation that may have a serious effect on early future conditions. Steel dealers here report a situation that is rapidly becoming serious, and they look forward to an early revision of prices that will reflect the actual condition of the market. While no local price changes have been out into effect, the early future is expected to show some interesting developments in an upward direction. The production of billets and sheet bars has been entailed owing to

the non-delivery of raw material, and higher prices are not unlikely. Pittsburgh quotations on rolling billets show an advance of \$2 per ton. The demand for ferro-alloys has quieted down, but prices are very firm. The situation in plates continues tense, as the mills are unable to supply the abnormal requirements of shipbuilders and general manufacturers. The sheet situation is unchanged and very firm, with early future prices depending on current developments. Wire and wire products retain an even tone, but owing to the high cost of wire rods, an early advance on wire products is not unlikely. Activity in bars is better, the demand having improved. Inquiries for wrought iron pipe and boiler tubes are good, and further advances may be looked for.

Metals

The general metal situation is without change, being still affected by the freight situation and the continued political uncertainty. Metals coming from the West are greatly delayed, and the spot supply is scarce. With the exception of tin, all metals are in a strong position. Copper is firm, but inactive. The knowledge that tin is easier would indicate that the marine risk has been lessened. Spelter is quiet, but prompt metal is scarce. Lead is very strong on the outside market. Delayed delivery of antimony has created a stronger market.

Copper.—The quiet state of the market gives little opportunity to get a definite line on the situation. Little activity is taking place, and the trade is apparently awaiting developments on which their future operations may be based. The London market is a little easier, while quotations in New York are higher; lake is quoted at 36c, with electrolytic at 37c, these prices being 1c and ½c higher than last week. Local conditions remain firm and unchanged, with quotations steady at 40c for lake and electrolytic, and 39c for castings.

Tin.—Conditions exist throughout the market that tend to irregularity in price quotations, as each transaction is considered on its own merits. The market on the whole is lower than last week, both in London and New York; the latter being ½c easier than a week ago, the current price being 49½c per lb. Dealers here report an easier market, but prices are unchanged at 51c per lb.

Spelter.—There is little activity in spelter, and buying and selling are almost at a standstill. A stronger tendency is noted, due to the scarcity of spot metal, caused by freight congestion. New York is quoting 107½c, this being an advance on last week of 5½c per lb. Spelter remains firm locally at 15c per lb.

Lead.—While prices are higher in the open market, all quotations are of a nominal nature. The trust continues to quote 8½c, but independents are asking as high as 10¾c. An undertone of strength is noted in local circles, but the nominal quotation is still 12½c per lb.

Antimony.—This metal is again advancing owing to the apparent scarcity

arising out of the delay in shipments now en route from the East. The situation here is strong on an advance of 4c, the quotation being 34c per lb.

Machine Tools and Supplies

While the present activity is not abnormal, the trade is experiencing great inconvenience owing to difficulty in obtaining supplies and inability to ship their product with any degree of definite delivery. Greater interest is being shown by shell manufacturers regarding machine equipment, due to the prospect of further renewals of munition contracts. While no definite information on this point is available, it is expected that additional orders will be placed in the near future for increased quantities of shells, involving still further additions to plant. Prices continue to hold firm, and prospects indicate still higher prices. The situation in the States is still subject to political influences, and manufacturers are cautious about closing contracts for future business.

Scrap

The freight situation is reflected in the stronger position of all scraps, and prices have an upward tendency, which may be still further pronounced unless relief is given to the present railroad congestion. Dealers report good business, but the volume is light. From one half to one cent has been added to New York quotations. The local changes are confined to copper and brass scrap and machine composition. Coppers have advanced 1c on the week, the current price being 23c and 27c per lb. Machine compositions are now 22c, and brass clippings 18c, these showing an advance of ½c per lb.

Toronto, Ont., Feb. 27.—The industrial situation continues to be affected by the shortage of fuel and raw materials. Although the movement of cars has been heavier, assisted materially by the milder weather, there still remains a considerable volume of freight to move before the congestion is relieved sufficiently to bring about reasonably normal conditions. The extensive embargo which has been placed on imports into Great Britain by the British Government will affect Canadian export to some extent on a number of lines. As the bulk of the export trade consists at present of foodstuffs and war materials, the effect will not be serious. The exportation of most of the manufactured goods regarded by the British Government as non-essentials and included in the prohibited list has steadily declined during the past two years.

Steel

Although the railways have been able to relieve the congestion to some extent aided by more favorable weather, the situation as it affects the steel trade in this section of the country cannot be said to have improved materially. The amount of coke and pig iron received at the furnaces has been quite inadequate and it has not been possible to extend operations. Output at the furn-

aces has therefore not increased, and steel production as a result has been curtailed. It is reasonable to suppose however that during the next three or four weeks, provided the weather is not too severe, there will be a considerable improvement effected and result in more favorable conditions at the mills and foundries. The export demand for steel continues insistent, the mills having already booked considerable business for 1918. The steel market is thus very strong and prices are advancing. Pressed steel spikes have advanced 50c and are now quoted at \$4.60 per 100 lbs. It is understood that the Dominion Government has an enquiry out for 6000 kegs for delivery from June 15 to Sept. 1, this year. Boiler and structural rivets are higher being now quoted at \$6.35 and \$6.25 per 100 lbs. respectively. Cut nails have advanced 20c to \$4.70. There has been a sharp advance recently in wire products, including wire nails, as a result of the continued high price and scarcity of wire rods. A sale, it is reported, of soft Bessemer or open hearth wire rods was made recently to Canadian interests on a basis of \$80 f.o.b. mill, Pittsburgh. Smooth steel wire No. 0-9 gauge is now quoted locally \$5.25 base, and wire nails \$4.95 per keg base. The demand for plates continues very heavy and prices are very firm with a decided upward tendency. Higher prices on boiler tubes are also looked for in the near future owing to the heavy demand and sold-up condition of the mills.

The sheets mills continue to operate at reduced capacity owing to the shortage of sheet bars and lack of fuel. On this account many mills are working part time or are closed down altogether. Deliveries are consequently falling behind and prices are tending upwards. It is fully expected that there will also be an advance on galvanized sheets shortly.

The shortage of fuel continues to be the principal feature in the steel trade in the United States. Although there has been quite recently an improvement in the railway situation, there is no real measure of relief to the mills and the output of semi-finished and finished steel this month is bound to show a heavy falling off as compared with January. The congestion at the seaboard is as acute as ever and railway embargoes are operative in all directions. Prices on all steel products continue very firm and advances have been made on billets and sheet bars. Forging billets are now quoted at \$90, open hearth billets \$65, and wire rods \$80 per ton, Pittsburgh. Tank plates are up to 5c and steel hoops to 3.75c Pittsburgh.

Pig Iron

The pig iron market continues very strong with very little improvement in freight conditions. The difficulty being experienced in getting coke and other raw materials, combined with a shortage of labor is checking furnace production. A large number of furnaces in the

States are banked owing to the shortage of coke, while this material is also increasing in cost. The situation in Canada is still acute with no immediate relief in sight.

Scrap

The market is strong and active with good demand particularly for steel scrap. No price changes have been made during the week, but advances on some lines of old material are looked for in the near future. Low phosphorous steel scrap is in good demand and prices are high owing to the high cost of low phosphorous pig iron. There is a moderate demand for steel borings and turnings at prices last quoted. Supplies of this material are in good volume. Prices of old copper and brass are firm at unchanged quotations.

Machine Tools

There is practically no change in the situation. The market is inclined to be dull as demand is comparatively light at the present time. Fuse manufacturers have been in the market for single tools to balance up equipment to increase production. There is also a fair demand for tool-makers' equipments. The embargo which the British Government has placed on a large variety of imports may affect the trade in Canada, unless the tools are urgently required for munitions plants and cannot be obtained in Great Britain.

Supplies

Business continues active and prices on practically all lines of machine shop supplies are very firm. There have not been many changes of importance announced during the week, but indications point to higher values all round. Lead wool is up 1c, and is now 15c per lb. Some new discounts on twist drills and reamers will be found in the selected market quotations.

Metals

The possibility of the United States entering the war is the principal feature in the metal markets. Such a development would doubtless result in an increased demand for metals for war purposes, and consequently prices would advance. This expectation is giving a strong tone to the markets and prices are very firm, although nominal for most of the metals. Copper, spelter and lead are higher, prices of other metals being unchanged. Business locally continues very good, and there is an optimistic feeling in the trade.

Copper—The market continues strong and quotations are nominal as there is not sufficient business to establish prices, there being very little copper actually offered for sale. Copper has advanced 1c locally and is now quoted at 39c per pound.

Tin—The situation is very strong and prices have an upward tendency. The possibility of cargoes of tin being lost through submarine activities is affecting the situation and will tend to keep prices firm. Local quotations unchanged and nominal at 56c per pound.

Spelter—The higher cost of zinc ore is reflected in an advance in spelter, producers having marked up quotations. Spelter has advanced ½c, and is quoted at 14c per pound.

Lead—The continued scarcity of lead in the East on account of the freight situation has resulted in a further advance in price as fixed by independents who are quoting 10.25c to 10.75c New York, although the "Trust," price is unchanged at 8.50c New York. Lead has advanced ½c locally, and is now quoted at 12½c per pound.

Antimony—The market is quiet, but firm. A scarcity of spot antimony has developed which is tending to advance prices. The freight congestion is affecting the situation. Local quotation unchanged at 35c per pound.

Aluminum—Quotations are firm, spot metal being at a premium in the East on account of the railway situation. Local quotation firm and unchanged at 68c per pound.

CANADIAN GOVERNMENT PURCHASING COMMISSION

The following gentlemen constitute the Commission appointed to make all purchases under the Dominion \$100,000,000 war appropriation:—George F. Galt, Winnipeg; Hormidas Laporte, Montreal; A. E. Kemp, Toronto. Thomas Hilliard is secretary, and the Commission headquarters are at Ottawa.

BARRED FROM IMPORT BY GREAT BRITAIN

THE Official Gazette gives a list of articles, the importation of which is prohibited into Great Britain as from Feb. 24, 1917. The list includes agricultural machinery, boots and shoes of leather, raw fruits except lemons and oranges, hides, leather, gloves, glass manufactures, linen and yarns and manufactures thereof, canned lobsters and salmon, manufactured silk and skins, furs, food articles containing sugar, except condensed milk; tomatoes, typewriters, wine of all kinds, wood and timber, aerated, mineral and table waters; anti-mony ware, apparel not water-proofed, works of art, baskets and bamboo, basketware, books, and other printed matter, including posters and daily and weekly and other periodicals exceeding 16 pages; materials for the manufacture of leather boots and shoes, brandy, clocks, and parts thereof, cloisonne ware, raw cocoa and preparations thereof, coffee, cotton hosiery, cotton lace and articles thereof, curries, diatomine and infusorial earth, embroidery and needle-work, fancy and ornamental feathers and down, fire extinguishers, flowers, artificial and fresh; hats and bonnets, incandescent gas mantles, raw jute mats and matting, mops, painters' colors and pigments, perfumery, photographic ap-

paratus, pictures, prints, engravings, photographs and maps, plated and gilt wares, live quails, quebracho, hemlock, oak and mangrove extracts, rum, Soya beans, stereoscopes, straw envelopes for bottles and straw plaiting, tea. Both wet and dry hides and dressed and undressed leather are included. Silky yarns are exempted. The prohibitions do not apply to goods imported under license given by the Board of Trade.



TORONTO HARBOR DEVELOPMENT PROGRAMME

OVER \$3,000,000 may be spent on harbor development work this year by the Toronto Harbor Commission in addition to \$1,000,000 which the Dominion Government has placed in the estimates for 1917. Detailed plans are now in process of being worked out by the engineering staff of the Commission, and will shortly be submitted to the city by the Commissioners for approval. There is, however, just a possibility that very little work can be undertaken this year, owing to the scarcity of timber, due to export and labor shortage. All timber used this year will have to be brought from British Columbia and present prices are such that the cost may be considered prohibitive. It was originally intended that the new harbor would be completed some time during the year 1921. This is no longer considered possible.

This Year's Plans

Plans for this year contemplate a beginning on the cribbing and piling for the docks in the central district between John and Cherry streets. This work will have to be undertaken in piecemeal fashion so that present dockage facilities will not be interrupted. This year the sinking of piles will, it is expected, only be proceeded with as far east as Spadina avenue. There will also be work along this line, beginning at the old Queen's wharf.

Further reclamation work will be undertaken in Ashbridge's Bay, the industrial district, providing several hundred additional acres for new industries. The Government will be asked to proceed with the retaining wall opposite the Exhibition Grounds and the Harbor Commission will then undertake the work of pumping sand over and filling in.

About \$400,000 is to be spent on reclamation work at Centre Island and Hanlan's Point. A block of about fifty acres is to be reclaimed at Centre Island on the immediate west side. Twenty-five acres is to be reclaimed at Hanlan's Point north of the wharf and baseball park. Both of these sections were commenced last year and will, if possible, be completed during 1917.

Estimates for 1917

The estimates of the Harbor Commission show the following contemplated expenditures for 1917:

Construction and acquiring of property, and its equipment, \$2,997,763.21; stores and rotary, \$41,580; insurance \$23,346; engineering and management,

Enlarged Canadian Trade Intelligence Service

Under the arrangement made by the Minister of Trade and Commerce with Sir Edward Grey in July, 1912, the Department of Trade and Commerce, Ottawa, is able to present the following list of the more important British Consulates whose officers have been instructed by the Foreign Office to answer inquiries from and give information to Canadians who wish to consult them in reference to trade matters.

BRAZIL—Bahia, British Consul. Rio de Janeiro, British Consul General.	NETHERLANDS—Amsterdam, British Consul.
CHILE — Valparaiso, British Consul General.	PANAMA—Colon, British Consul. Panama, British Vice-Consul.
COLOMBIA — Bogota, British Consul General.	PERU—Lima, British Vice-Consul.
ECUADOR—Quito, British Consul General. Guayaquil, British Consul.	PORTUGAL—Lisbon, British Consul.
EGYPT — Alexandria, British Consul General.	RUSSIA—Moscow, British Consul General. Petrograd, British Consul. Vladivostok, British Consul. Odessa, British Consul General.
FRANCE—Havre, British Consul General. Marseilles, British Consul General.	SPAIN—Barcelona, British Consul General. Madrid, British Consul.
INDIA—Calcutta, Director General of Commercial Intelligence.	SWEDEN—Stockholm, British Consul.
ITALY—Genoa, British Consul General. Milan, British Consul.	SWITZERLAND—Geneva, British Consul.
MEXICO—Mexico, British Consul General.	URUGUAY—Monte Video, British Vice-Consul.
	VENEZUELA — Caracas, British Vice-Consul.

Canadian Commercial Intelligence Service

The Department of Trade and Commerce invites correspondence from Canadian exporters or importers upon all trade matters. Canadian Trade Commissioners and Commercial Agents should be kept supplied with catalogues, price lists, discount rates, etc., and the names and addresses of trade representatives by Canadian exporters. Catalogues should state whether prices are at factory point, f.o.b. at port of shipment, or, which is preferable, c.i.f. at foreign port.

CANADIAN TRADE COMMISSIONERS.

ARGENTINE REPUBLIC—H. R. Poussette, Reconquista, No. 46, Buenos Aires. Cable address, Canadian.
AUSTRALIA—D. H. Ross, Stock Exchange Building, Melbourne. Cable address, Canadian.
BRITISH WEST INDIES—E. H. S. Flood, Bridgetown, Barbadoes, agent also for the Bermudas and British Guiana. Cable address, Canadian.
CHINA—J. W. Ross, 13 Nanking Road, Shanghai. Cable address, Cancom.
CUBA—Acting Trade Commissioner, Lonja del Comercio, Apartado 1290, Havana. Cable address, Cantracom.
FRANCE—Phillipe Roy, Commissioner General, 17 and 19 Boulevard des Capucines, Paris. Cable address, Stadacona.
JAPAN—G. B. Johnson, P. O. Box 109, Yokohama. Cable address, Canadian.
HOLLAND—Acting Trade Commissioner, Zuidblaak, 26, Rotterdam. Cable address, Watermill.
RUSSIA—C. F. Just, Canadian Government Commercial Agent, Alexandrivskaya, Ploshch 9, Petrograd. L. D. Wilgress, Canadian Government Commercial Agent, Bukhholza Flitza No. 4, Omsk, Siberia.
NEWFOUNDLAND—W. B. Nicholson, Bank of Montreal Building, Water Street, St. John's. Cable address, Canadian.
NEW ZEALAND—W. A. Beddoe, Union Buildings, Customs Street, Auckland. Cable address, Canadian.
SOUTH AFRICA—W. J. Egan, Norwich Union Buildings, Cape Town. Cable address, Cantracom.
UNITED KINGDOM—Harrison Watson, 73 Basinghall Street, London, E.C., England. Cable address, Sleighing, London. N. D. Johnston, Sun Building, Clare Street, Bristol. Cable address, Canadian. J. E. Ray, Central House, Birmingham. Cable address, Canadian. J. Forsyth Smith, 27-28 Pearl Building, East Paradise, Leeds. Cable address, Canadian. F. A. C. Bickerdike, Canada Chambers, 36 Spring Gardens, Manchester. Cable address, Cantracom. J. T. Lithgow, 87 Union Street, Glasgow, Scotland. Cable address, Cantracom.

SPECIAL TRADE COMMISSIONER—LUMBER

H. R. McMillan, visiting Europe, Africa, Australasia and the Orient.

CANADIAN COMMERCIAL AGENTS

AUSTRALIA—F. Millin, Exchange Building, Sydney, N.S.W.
BRITISH WEST INDIES—Edgar Tripp, Port of Spain, Trinidad. Cable address, Canadian. R. H. Curry, Nassau, Bahamas.
NORWAY AND DENMARK—C. E. Sontum Grubbeleg No. 4, Christiania, Norway. Cable address, Sontums.

CANADIAN HIGH COMMISSIONER'S OFFICE

UNITED KINGDOM—W. L. Griffith, Secretary, 17 Victoria Street, London, S.W., England. Cable address, Dominion, London.

\$180,290; revenue producing service, \$32,120; upkeep of property and equipment, \$11,000. The revenue and proceeds of the Harbor Commission from 1912 to 1916, inclusive, total \$6,672,466.78, and the expenditure for the same period was \$6,311,775.81, leaving a surplus of \$340,690.97. The estimated revenue for 1917 is placed at \$160,000.

This year's estimates provide for \$60,000 for freeholds in Eastern avenue properties, and \$20,000 for the Boulevard-Cliff Road, and \$2,000 for a long-time lease hold of the Eastern sandbar. The sum of \$150,000 is provided for a new office building. Bath houses, including public protection, are to cost \$5,000.

Improve Industrial Area

For roadways there are the following expenditures: Boulevard drive, Cliff Road, \$15,250; Boulevard drive, Wilson to the Humber, \$87,984; 150 foot roadway, Cherry street to the Don, \$10,000, and in the industrial district, \$10,000. Sidewalks and curbs call for the following expenditures: Boulevard-Cliff Road to the Humber, \$55,000; 150-foot roadway, Cherry street to the Don, \$5,000, and in the industrial district, \$25,000.

The Cherry street bascule bridge is to cost \$50,000, and the Don railway bridge \$43,280. Piers, docks, and quays call for \$750,369.64, being four sections of the harbor head walls, two of which are under contract. Just where these will be located has not yet been made public. In addition to the above there is an appropriation of \$65,000 for the Humber bastion wall.

Underground service appropriations provide for storm sewer overflow extensions at Keele street, Garrison Creek, and Bathurst streets, Booth, Logan and Carlaw avenues, and for a storm sewer in the industrial district, the total estimated cost being \$281,591.10. Railways, tramway embankments and tracks will require \$60,000.

\$708,333 for Dredging

Estimates for non-structural improvements include \$658,333 for dredging under the Canadian Stewart Co. contract, and \$50,000 for the Harbor Commissioner's plant. An even \$100,000 is provided for general retention work and \$7,000 is due to be spent on surfacing in the industrial district, in the vicinity of the Sunnyside pavilion and at the Parkdale Canoe Club. The sum of \$15,200 is set aside for razing structures and removing obstructions.

Payment of debts and payment to sinking fund will take \$296,000. Initial construction of pile drivers, scows and betterments to dredges, derricks, pile drivers, and to tug, will, it is estimated, require \$30,000. The sum of \$25,000 is in the estimates for a marine railway and \$2,350 for power tools. There is also \$15,000 for the Sunnyside pavilion and \$1,500 for dockyard fences. Plant operation will require \$18,080, and stores, comprising construction, stationery, motor service and commissariat, \$20,900.

IN STOCK
NO. 6 WARNER & SWASEY
TURRET SCREW MACHINES

Geared Friction Head, Auto Chuck—Power Feed, 2 in. Bar Capacity. Specially adapted for

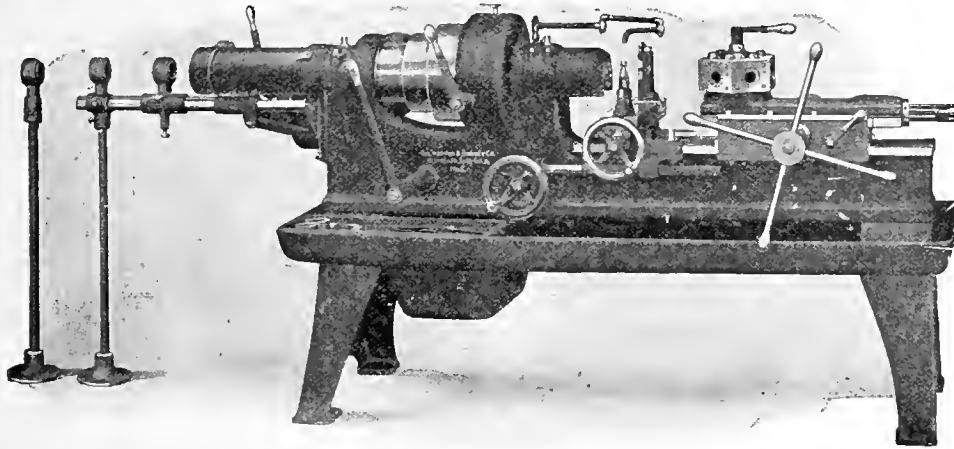

FUSE BODIES and FINISHING NOSE and FUSE HOLE OF 4.5 in., 6 in., 8 in. and 9.2 in SHELLS.

—
 SEND FOR FULL
 PARTICULARS
 —

WRITE FOR OUR LATEST STOCK LIST
 —JUST ISSUED.

THE A. R. WILLIAMS MACHINERY COMPANY, LIMITED
 64-66 Front Street, West, TORONTO

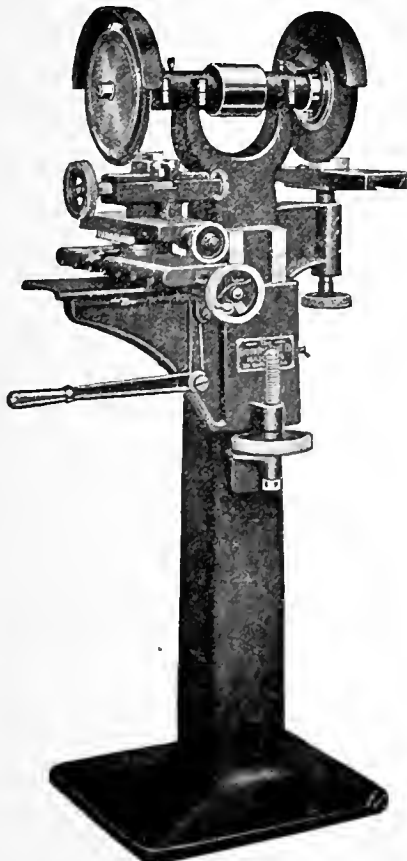

**NO SCREW-CUTTING TOOL CAN
 BE SUCCESSFULLY OPERATED**

Without Proper Grinding or Sharpening

**THE GEOMETRIC CHASER
 OR DIE GRINDER**

is a machine carefully designed and constructed for the correct grinding of thread chasers and dies.

Its use is economy where threading tools are employed.

It not only keeps all the chasers of a set in condition for perfect work, but at the same time prevents excessive wear on one or two of the chasers.

THE GEOMETRIC grinds any make of thread chaser, whether of a stock or special type. Also fitted with a second grinding wheel for ordinary tool grinding.

SEND FOR DESCRIPTIVE BOOKLET.

The GEOMETRIC TOOL COMPANY
 NEW HAVEN, CONN., U.S.A.

CANADIAN AGENTS: Williams & Wilson, Limited, Montreal;
 The A. R. Williams Machinery Co., Limited, Toronto, Winnipeg, St. John, N.B.

If any advertisement interests you, tear it out now and place with letters to be answered.

INDUSTRIAL ^A_D CONSTRUCTION NEWS

Establishment or Enlargement of Factories, Mills, Power Plants, Etc.; Construction of Railways, Bridges, Etc.; Municipal Undertakings; Mining News

ENGINEERING

Montreal, Que.—It is understood that the G.T.R. is in the market for twenty-five locomotives.

Ladysmith, B.C.—It is proposed to start operations at the smelter here, also to extend the plant.

Kitchener, Ont.—Fire did \$475 worth of damage to the Gies Foundry, on Water street, on Feb. 23.

Sherbrooke, Que.—Mackinnon, Holmes & Co. will rebuild their plant which was recently destroyed by fire.

Port Hope, Ont.—The Brandon Machine Co., is installing machinery at the new plant here. The tool room is already in operation.

Oil Springs, Ont.—The Canadian Oil Products Co., will replace its oil-pumping machinery recently destroyed by fire with a loss of \$5,000.

Chignecto, N.S.—The Maritime Coal, Railway & Power Co., proposes to purchase electric pumps, motors, etc., for to plant. R. J. Bell is general manager.

Fredericton, N.B.—Fraser Ltd., of this town are building a bleached sulphite pulp mill at Edmnnston, N.B., which will have a capacity of about 100 to 125 tons per day.

Three Rivers, Que.—The Quebec Steel Foundries, Ltd., are building a plant here. Messrs. Massicotte and Gagnon, of Ste. Anne de la Perade, are interested in the company.

Eburne, B.C.—The British Pacific Iron & Steel Co. has placed an order for open-hearth furnaces for the steel plant they will erect on the Fraser River, near Eburne. A site of 10 acres has been secured.

Vancouver, B.C.—The Pacific Mills, Ltd., Ocean Falls, B.C., is erecting a pulp and paper mill of 100 tons a day capacity to be ready for operation by April. It is owned by the Crown Willamette Paper Co. of Vancouver.

Guelph, Ont.—In a few weeks the International Malleable Iron Co., expects to proceed with the erection of a large addition to their plant. The new building will be 216 feet long, one storey high. Tenders are now being received for the construction.

Trenton, Ont.—The British Chemical Co. have extended their plans and have purchased a large block of land in Patricia Park. Messrs. Fraser, Brace & Co., of Montreal, have a contract to erect between thirty and forty buildings on this property for a smokeless powder plant.

Windsor, Ont.—Preparations for the development of the quarries at Amherstburg by the Solvay Process Co. are al-

ready under way. Gordon S. Rutherford, newly appointed general resident manager of the company, has already taken charge and has planned his campaign.

Port Arthur, Ont.—Arrangements are being made by the Grain Growers' Grain Co., which recently erected a hospital elevator here with a storage capacity of 200,000 bushels, for the doubling of that storage capacity. This will necessitate the construction of nine or ten new tanks. Work is to be started as soon as possible.

Montreal, Que.—The Montreal Locomotive Co. have taken out permits for the erection of four distinct additions to their plant. All of these buildings will be located on Notre Dame east, and together will cost in the vicinity of \$6,300. There will be one 45 x 290 to cost \$1,400, a second 84 x 32 to cost \$1,400, a third 84 x 32 to cost \$1,300, and a fourth 100 x 200 to cost \$1,800.

Campbellford, Ont.—Work has begun on the rebuilding of the Dickson Bridge Co.'s plant here, which was burned some weeks ago. It is stated that the National Mfg. Co., of Ottawa and Brockville, have purchased a controlling interest, but that the firm will still be known as the Dickson Bridge Works Co. Men are now at work reconstructing the buildings. A. H. McKeel has charge of the work.

Toronto, Ont.—The Local Board of Health has granted to W. Harris & Co., Danforth avenue, a permit to establish in the Ashbridge's Bay harbor industrial area 175 feet east of the diversion of the River Don, a plant for the manufacture of gelatine, glues and renderings. The initial unit of the plant will cost about \$50,000, but extensions will be made at a later date.

Montreal, Que.—The Thomas Davidson Mfg. Co., have taken out a permit to erect a plant near the Lachine Canal, between the Canada Car and Dominion Mahogany factories, to cost in the vicinity of \$25,000. This plant will have dimensions of 200 x 50 and will be used for the manufacture of munitions while the war lasts and then will be used in the manufacture of the company's ordinary product.

Hull, Que.—The Hull Iron & Steel Foundries are making considerable extensions to their plant, including a machine shop extension, 40 ft by 90 ft.; office building to cost \$20,000; two 20-ton, open-hearth furnaces, approximate cost \$50,000. New equipment to be installed will consist of one 30-ton overhead traveling crane for the main foundry; one 10-ton crane, 40 ft. span, with 800 ft. runway, into the yard. Three

heavy duty engine lathes will also be required.

Cornwall, Ont.—The Town Council who for some time past have been endeavoring to obtain power, believe that 5000 additional horse power will be supplied by the Cedar Rapids Transmission Co. The company's engineers are now at work on plans for a transmission house and plant to be erected near here as soon as it is possible to get the project under way. It is expected that a unit of 3,000 horse power will be installed. The plant will be designed and built so as to permit additional units being quickly installed.

MUNICIPAL

Sudbury, Ont.—The Town Council proposes to spend \$7,000 on extensions to its power plant. W. J. Ross is clerk.

Winnipeg, Man.—The City Council are considering enlarging the Point du Bois power plant to 100,000 h.p., at a cost of \$150,000.

Englehart, Ont.—The Northern Ontario Light and Power Co. have now completed their transmission line to Kirkland Lake, a distance of approximately sixty-five miles.

Merrickville, Ont.—A by-law to grant a bonus of \$30,000 to the Rideau Power Co., was carried by a large majority by the ratepayers on Feb. 26, only five votes being cast against it.

St. Vital, Man.—The Rural Municipality of St. Vital have for sale approximately 7,000 feet of 6 in. cast iron pipe, specials hydrants, valves and boxes. J. Desourdis is sec-treasurer.

Chatham, Ont.—The City Council has endorsed the proposition of the Public Utilities Commission whereby it is proposed that the city purchase the electrical business of the Chatham Gas Co. for \$115,000, thus extending the present hydro system and removing all competition.

Montreal, Que.—The Board of Control may sanction an increase in cost of the Lasalle bridge. T. O'Sullivan was awarded the contract for the work at \$209,000 but claims that \$30,000 more than that sum would be required to cover the increased cost of materials.

Chatham, Ont.—The City Council has endorsed the proposition of the Public Utilities Commission whereby it is proposed that the city purchase the electrical business of the Chatham Gas Co. for \$115,000, thus extending the present hydro system and eliminating all competition. The matter will now be referred to the Ontario Municipal and Railway Board without a vote of the people.

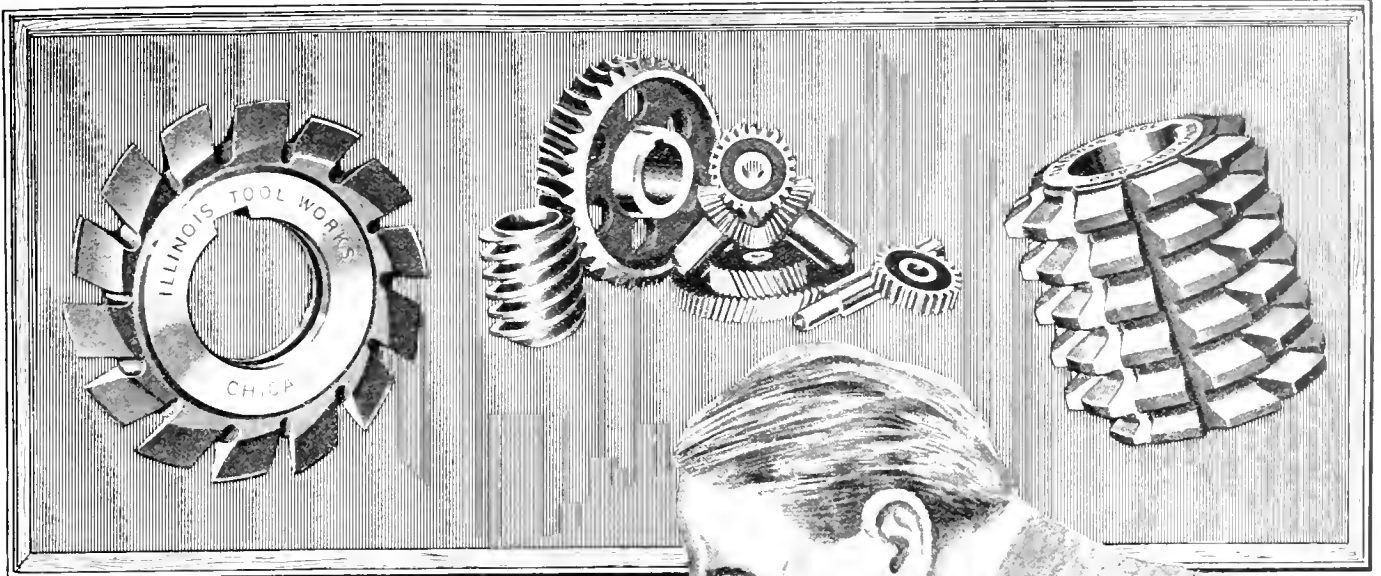

A Helpful Technical Service for Gear Makers

THIS Company maintains a completely equipped department for the designing and execution of SPECIAL hobs and cutters: a broad, constructive work which our engineers have been developing since the founding of this business. It has become an important, permanent feature of our service, now at the disposal of all who are confronted with perplexing tool problems, especially hobbing.

We would welcome the opportunity to demonstrate how you could use this service to advantage, and cordially invite you to confer with our Engineering Department in person or by letter.

ILLINOIS TOOL WORKS
 MANUFACTURERS AND DESIGNERS OF
CUTTERS · HOBS · REAMERS
 CHICAGO U.S.A.

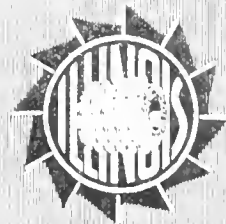

If any advertisement interests you, tear it out now and place with letters to be answered.

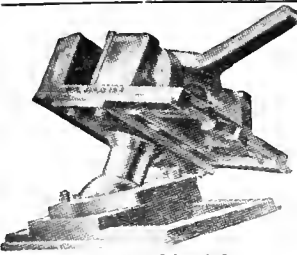

"VERDUN"
Quick-opening
VISES

Plain Model—
Without Ball
Socket.
Universal
Model—With
Ball Socket.
For Bench and
Machine - Tool
work.

They are:—
Universal Model
Rigid—Quick in Action—Reliable in Service.

WELBORNE & CO. (Machinery)
South Ferry Building, New York, U.S.A.

GENERAL

Stratford, Ont.—The McLeod Milling Co. are in the market for electrical equipment.

London, Ont.—The Quaker Oats Co., of Peterboro, propose to erect a \$100,000 addition to the local plant, which they recently acquired.

Winnipeg, Man.—Fire on February 22 in the premises of the Great West Saddlery Co. here caused damage to stock and building estimated at \$40,000.

Belleville, Ont.—The Maple Leaf Rubber Co., are building a factory here for manufacturing tires and rubber goods. The buildings will be completed early this summer.

Ste. Rese, Que.—Damage exceeding \$15,000 was done here on February 17 by a fire which partially destroyed the saw mill of Cyr & Freres.

Windsor, Ont.—The Canadian Oil Co. proposes to erect a factory for the manufacture of oils, paints, etc. A by-law will be prepared and a vote taken on the question of the city selling a site on Howard Ave. to the company.

Montreal, Que.—A factory of 190 x 100 is now being completed for the Thompson & Norris Co. of Canada in the vicinity of Masson street and the Canadian Pacific tracks. This company formerly sold goods, corrugated paper products, in Canada through their factories in Brooklyn, Boston, and even London, England.

Westport, Ont.—The Dominion Cutlery Co. of Montreal, have taken over a plant to manufacture cutlery. The property is situated at Westport, Ont., and consists of two buildings, three storeys each, containing 22,000 square feet of floor space, a machine shop, plating plant and water power equipment. Additional machinery is now being installed, and the plant is now in operation. The officers of the company state that a general line of cutlery such as pocket knives, scissors, razors will be turned out for which a large number of orders are on hand.

TENDERS

Toronto, Ont.—Tenders, addressed to the chairman of the Toronto Electric Commissioners, will be received until March 25, for synchronous condensers. Specifications may be obtained at the office of the purchasing agent, 15 Wilton Avenue, Toronto.

Toronto, Ont.—Tenders will be received up to March 7, for the supply of road oils, asphalts, tars, and four oil wagons for the York Highway Commission. Specifications may be secured from E. A. James, township engineer, 57 Adelaide street, Toronto.

Victoria, B.C.—Tenders will be received up to March 5, for the following electrical supplies:—5,000 carbons, solid; 5,000 carbons, cored; 3,000 nitrogen lamps; tungsten lamps. Specifications may be obtained from W. Galt, city purchasing agent.

Winnipeg, Man.—Tenders will be received up to March 15, by R. D. Waugh, Chairman of Commissioners, Greater Winnipeg Water District, for the supply of approximately 12,500 feet of 48-in. and 1,300 feet of 60-in. cast iron pipes, together with specials and gate valves. Specifications on application to the offices of the District, 501 Tribune Building, Winnipeg.

Hamilton, Ont.—Tenders will be received by the Board of Control up to March 5, for the supply of ordinary and special castings, iron pipe, hydrants, valves, extension boxes, lead pipe, pig lead, rubber hose, rubber boots, road oil, lubricating oil, flux, fuel oil, coal oil, gasoline, brass work, including ordinary and special brass castings for water department, hardware, etc. Specifications may be obtained at the office of E. R. Gray, city engineer.

Quebec, Que.—Tenders will be received at the Quebec Harbor Commissioners' offices up to March 12, for the construction and delivery, in complete working order, in accordance with the exhibited plans and specifications, of a grain storage annex (of about 1,000,000 bushels capacity), to the commissioners' present concrete elevator No. 2. Plans and specifications of the proposed work may be seen, and forms of tender obtained, at the Harbor Engineer's office, Quebec.

REFRIGERATION

Chatham, Ont.—By a vote of \$46 to 105, the ratepayers on February 20 sustained a by-law to grant a site of eleven acres, valued at \$5,500, to Libby, McNeil & Libby Co. of Canada, for the establishment of a large packing and pickling plant. The company is a Canadian branch of the Chicago packing house of the same name. They will expend, to begin with, more than \$100,000 on a plant to care for business in Canada and British possessions.

INCORPORATIONS

The Mount Elgin Milk Products Ltd., has been incorporated at Toronto to manufacture butter, cheese and milk products of all kinds at Mount Elgin, Ont. The provisional directors are John A. Morrison, James W. Stoakley and Emerson Moulton all of Dereham Township, Ont.

McCallum-MacLaren Ltd., has been incorporated at Toronto with a capital of \$40,000 to manufacture sash, doors, vehicles and implements etc. with head office at Toronto. The provisional directors are B. George McCallum, Harvey L. McCallum and Charles D. MacLaren all of Toronto.

Metal Specialties Ltd., has been incorporated at Toronto with a capital of \$40,000, to manufacture metal products of all kinds, aeroplanes etc., and to carry on a general engineering business with head office at Toronto. The incorporators are Edwin G. Long, Harry S. Sprague and Joseph E. Belfry all of Toronto.

Davis-Bournonville Oxy-Acetylene Welding and Cutting Apparatus Leads the World

Over 2,400 plants in daily operation. Medal of Honor, Highest Award at Panama Exposition.

PORTABLE GENERATORS
STATIONARY GENERATORS
WELDING TORCHES
CUTTING TORCHES
REGULATORS
HOSE
CARBIDE
WELDING RODS
FLUX
CARBONITE RODS
GOGGLES
CARBON REMOVERS
PORTABLE TRUCKS
COMPRESSED ACETYLENE

Price list and full particulars on request.

Carter Welding Co.

9-11 Sheppard Street

TORONTO, ONT.

Phone Adelaide 2841

Canadian Agents for

The Davis-Bournonville Apparatus

The Lubricant Pump You've Looked For

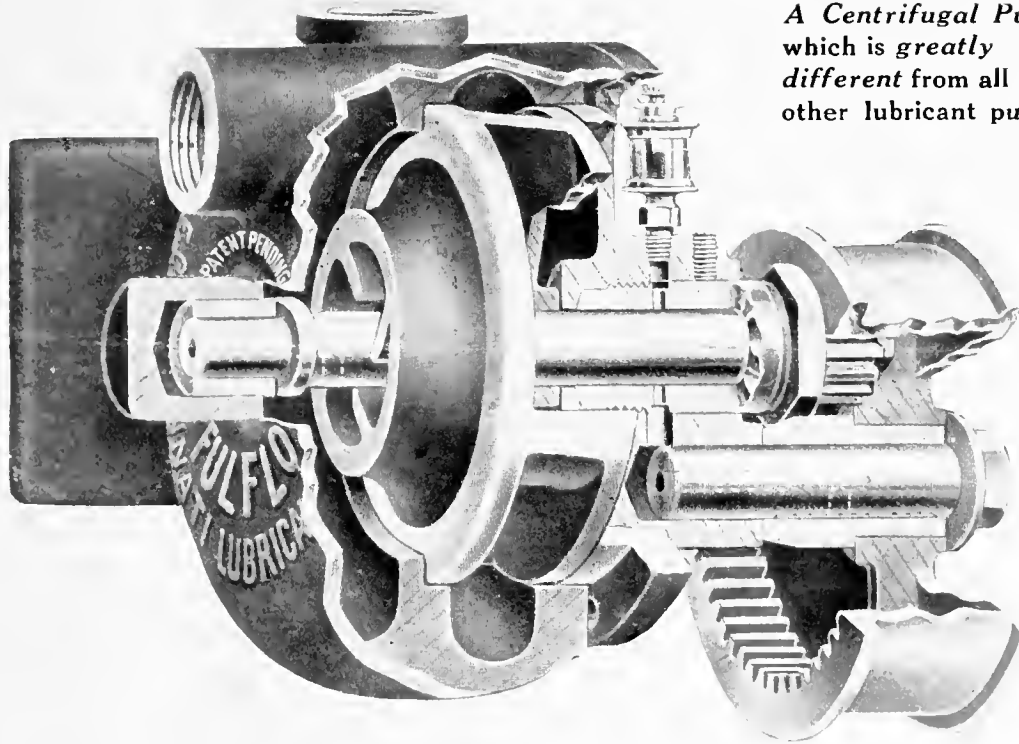

*A Centrifugal Pump
which is greatly
different from all
other lubricant pumps*

Fulflo Lubricant Pump

"The Pump Efficient"

1 GREATEST CAPACITY. 50% more volume than any other pump its size. 1 to 20 gallons per minute according to speed.

2 CANNOT LOSE ITS PRIME. Water has to run uphill before the Fulflo can lose its prime. All other pumps depend on valves to hold their prime.

3 LONGEST LIFE. There is but one pumping part—the impellor—and it touches nothing but the liquid; therefore retains its pumping efficiency indefinitely.

4 WON'T CLOG. Anything that can get in will go right through without injury to the pump. No passage smaller than intake which is $\frac{3}{4}$ inch.

Send for a copy of "Scientific Lubrication of Cutting Tools." It is FREE to all mechanical creatives.

The Cincinnati Lubricant Pump Company

126 Opera Place, Cincinnati, Ohio, U.S.A.

Alfred Herbert, Ltd.
Coventry, England

De Fries e C.
Milan, Italy

Why do you suppose such people as these are replacing the gear-type lubricant pumps which came with their machines with FULFLOS--the new centrifugal type lubricant pumps?

The Dayton Engineering Laboratories Co.
 LABORATORY AND EXECUTIVE OFFICES DAYTON OHIO
 FACTORY 24 DAYTON OHIO

The Cincinnati Lubricant Pump Co.
 126 Opera Place
 Cincinnati, Ohio

Gentlemen:

We are enclosing herewith copy of a letter to the _____ Co. requesting them to equip ten of our machines on order with your pumps.

Yours very truly,
J. L. Walter
 THE DAYTON ENGINEERING LABORATORIES CO.

Nothing but Fulflos will be used here.

E. C. ATKINS & COMPANY
 SILVER STEEL SAWS

The Cincinnati Lubricant Pump Company
 Cincinnati, Ohio

Gentlemen:

We are pleased to state that we have in operation at the present time a number of your Fulflo pumps and are having excellent service from them. We were a little skeptical about placing the first order sometime ago but after testing the first pump out thoroughly we were very much pleased with its performance and gave you two additional orders on the strength of the results we obtained. We have had no trouble at all so far in the operation of the pumps and are frank to say that you certainly have a very efficient pump for machine shop practice.

Yours truly,
 E. C. ATKINS & COMPANY
W. A. Atkins
 Supt.

Troubles Overcome
 Orders More Fulflos

They Insisted on Getting Fulflos

COPY

The _____ Co.
 _____ Ill.

Gentlemen:-

Referring to our order B-50622 for ten No. _____ Machines, we would like to know if it would be possible for you to furnish a "Fulflo" Lubricant Pump instead of the geared pump which you are furnishing at the present time. We have found this pump to be much better than the geared pump and we are at the present time replacing many of our geared pumps with this style of pump.

We are enclosing a circular giving a description of this pump and are also sending a copy of this letter to the Cincinnati Lubricant Pump Co. of 126 Opera Place, Cincinnati, Ohio.

Thanking you in advance for anything you can do for us in this matter we are

Yours very truly,
 F. L. Egan
 THE DAYTON ENGINEERING LABORATORIES CO.

The Cushman Chuck Company
 HARDWARE DEPARTMENT
CUSHMAN CHUCKS
 FACE PLATE JAWES
 Hartford Conn. U.S.A.

Gentlemen:

We are using your "Fulflo" Pump with great success and we consider them 100% better than the best type of Geared Pump which we have used heretofore. All our future orders will be for the "Fulflo" Pump and we recommend them to anyone who wishes to use a pump that will give them the least amount of trouble.

Yours very truly,
 THE CUSHMAN CHUCK COMPANY
A. P. Sloan
 Vice-President.

Fulflo Found to be the Best

Here are the names of several concerns in America which have in use from 100 to 600 Fulflo Lubricant Pumps.

- Buick Motor Company - Flint, Mich.
 - P. Lyall & Sons Construction Co. Montreal, Can.
 - Northway Motor Company - Detroit, Mich.
 - Wagner Electric Company - St. Louis, Mo.
 - Dayton Engineering Laboratories Dayton, Ohio
 - Remington U.M.C. Company Bridgeport, Conn.
 - Richmond Radiator Company Philadelphia, Pa.
 - Pennsylvania Railway Company Pittsburgh, Pa.
 - American Clay Machinery Company Bucyrus, O.
 - Russel Motor Car Company - Toronto, Can.
- and there are hundreds of others.

Send for a copy of "Scientific Lubrication of Cutting Tools." It is FREE to all mechanical executives.

The Cincinnati Lubricant Pump Company

126 Opera Place, Cincinnati, Ohio, U.S.A.

Alfred Herbert, Ltd.
 Coventry, England

De Fries e C.
 Milan, Italy

C. H. Rooke Ltd., has been incorporated at Ottawa with a capital of \$50,000 to carry on the business of manufacturers and distributors of Delco-Light products, gasoline engines and electrical devices etc. Head office is at Toronto and the incorporators are Francis P. Dawson, John E. Corcoran and William B. Horkins all of Toronto.

BUILDINGS

Toronto, Ont.—City Architect Pearse has granted a building permit to A. P. Morton to erect a brick garage at 248 Victoria Street at a cost of \$12,000.

Hamilton, Ont.—The Board of Control have decided to give the Board of Education the extra \$30,000 needed to build the proposed addition to the Adelaide Hoodless School. Debentures to that amount will be issued.

Toronto, Ont.—The Board of Education have received a permit from the City Architect to erect a three-storey brick school on the north side of Orde Street, near McCaul, at an estimated cost of \$75,000. This is an addition to the Orde Street School.

Toronto, Ont.—The Board of Education has made the following appropriations:—The sum of \$90,000 for the erection of a new school building, to contain at least 15 class rooms, for the relief of Winchester and Rose Avenue Schools; \$12,000 for the completion of the assembly room at the North Toronto High School; while \$15,000 was passed for the erection of a building to furnish more room for the supply department of the Board. An additional item of \$50,000 for six additional rooms at Dewson School was inserted, and a total amount for sites and enlargements, amounting to \$647,000, was passed.

RAILWAYS—BRIDGES

Calgary, Alta.—The C.P.R. will build a number of section houses and stations and also lay 8½ miles of pipe lines in this district.

Toronto, Ont.—The C.P.R. has filed the preliminary plans with the city for the construction of the double track from the new North Toronto station to Leaside. The plans include a new bridge at Summerhill Ave.

Toronto, Ont.—The Provincial Department of Highways will shortly be in a position to place at the disposal of municipalities standard bridge plans that will mean a saving of thousands of dollars every year. For some time past the engineers of the department have been at work preparing model plans of different types of bridges used in connection with county and township road construction, and these when ready will be supplied wherever needed.

CONTRACTS

Ottawa, Ont.—The General Supply Co. have been awarded a contract by the Works Department for two motor flushers, to cost \$7,815 each.

PERSONAL

Tracey E. Freeman, B.A.Sc., who has had charge of the Montreal sales office of Canadian Hoskins, Ltd. for the past eighteen months, is being transferred to the head office in Walkerville, Ont., as assistant general manager.

Capt. James Murray, one of the oldest captains on the lakes, passed away on February 21, at Clayton, N.Y. The deceased was born about 75 years ago in Ireland, but came to Canada at an early age and went into the marine business. For many years he was known in marine circles as one of the most capable of officers in handling boats for the Montreal Transportation Co. During the past year he had been retired.

J. H. Pillsbury, superintendent of the drydock at Prince Rupert, B.C., has been to Vancouver to arrange for engaging a staff and buying ship chandlery general stock for the plant. Mr. Pillsbury came from Winnipeg, where he was authorized by the G. T. P. officials to supervise the installation of a permanent staff. This will enable the plant to bid for all ship repair and overhauling jobs, construct wooden ships, and smaller types of steel craft.

Brig-Gen. W. A. Whyte, of the Imperial service, was in Toronto recently on a special mission for the British Government concerning the manufacture of munitions in Canada, and about which he is preparing a report for the British Minister of Munitions. Before leaving for Montreal, Gen. Whyte expressed himself as being well pleased with the result of his examination so far, and declared that the work of munition factories here was immensely satisfactory.

T. McHattie, master mechanic, Eastern Lines, Grand Trunk Railway System, Montreal, has resigned. He will be succeeded by **W. H. Sample**, formerly master mechanic at Battle Creek, Michigan. Mr. McHattie has been a prominent figure in Montreal railway circles for many years. He came to Montreal nineteen years ago as master mechanic of the Grand Trunk shops, and after nine years' service in that position took up the post of superintendent of motive power on the Central Vermont Railway. He returned to Montreal as master mechanic of the Grand Trunk Eastern Lines in 1910.

MARINE

Victoria, B.C.—The Cameron Genoa Mills Shipbuilders expect to launch the Laurel Whalen, the second of the auxiliary powered schooners, which they are now building, on March 19.

Victoria, B.C.—Capt. J. W. Troup, manager of the C. P. R. Coast steamship service, states that he had been authorized to call tenders for the construction of two ear barges to be used in the local trade. The ear barges will be of wooden construction, each with a capacity of nine ears. They will have a length of 150 feet and a beam of 46 feet. Plans are now being prepared and bids will be called shortly.

PURO

(MADE IN CANADA)

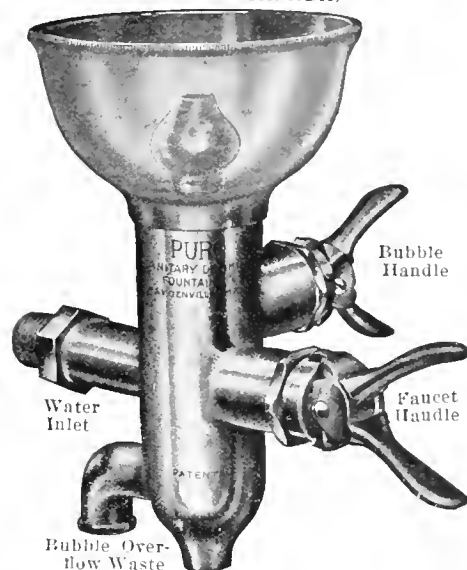

Actual Size 7" High.

Stop That Waste of Water

Did you ever stop to think how many gallons of water are wasted by the old-fashioned drinking faucet?

Puro saves 35% of that wasted water.

Puro does away with the old-fashioned unsanitary tin-cup; it is the Safety Sign of pure water in every factory where it has been installed.

Employees like it because it is clean—because it insures a clean fresh drink—because it saves their time.

The Puro Sanitary Drinking Fountain has a positive control that eliminates spurring.

Easily attached—positively fool-proof—and nothing to wear out.

An excellent investment—for shop and office alike—and one that pays dividends in real money on water savings and better workers.

Write to-day—now—tell us how many men you have and the number of departments.

We'll make you a complete estimate on an installation—we will also make you a special proposition for a try out in any one department.

"PURO-FY" Your Water Supply

Puro Sanitary Drinking Fountain Company

SAFETY PURO ECONOMY
FIRST ALWAYS

147 University Ave., TORONTO, CAN.

THE IRON WORKS LIMITED

Successors to

Owen Sound Iron Works

Owen Sound, Ont.

Engineers

Boiler-makers

Founders

Machinists

Tank Work
Smoke Stacks,
Grey Iron and
Brass Castings,
Special
Machinery
Made to
Order

"Barnes-Made" SPRINGS

are unusual in service and wear

They are the result of sixty years' experience, unsurpassed equipment and highly skilled workmanship.

A trial will convince you that "Barnes-Made" Springs are the best buy.

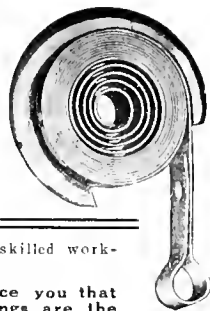

Established 1857

THE WALLACE BARNES COMPANY

218 South St., Bristol, Ct., U.S.A.

Mfrs of "Barnes-made" Products
Springs, Screw Machine Products, Cold Rolled Steel and Wire

"HAWK" D CHROME VANADIUM STEEL



Will
Give You
Exceptional

Shell Forging Production

WITHOUT AN EQUAL FOR
BOTH FIRST AND
SECOND OPERATION
PUNCHES.

Comes to you heat-treated
and ready for use.

It does not stick to the
work.

There are many cases where
each punch has turned out
over 2,000 shells.

It means more shells, per
machine per day.

STEEL OF EVERY
DESCRIPTION.

Hawkrige Brothers Company

303 Congress St., BOSTON, MASS.
U. S. A.

TRADE GOSSIP

The Hull Iron & Steel Foundries, Ltd., of Hull, Que., have opened a sales office at 165 Broadway, New York City, to take care of their export business.

Trade Enquiries.—The Department of Trade and Commerce, Ottawa, has received the following enquiry, No. 579 for carbon twist drills. A London firm invites offers from Canadian manufacturers of carbon twist drills who can fill orders for export, particularly to Russia.

Japs Building Ships.—It is reported that a Japanese shipbuilding firm building stock boats on speculation has sold seventeen of them to British owners for delivery within the next six months. The tonnage involved is stated at 159,000 tons dead weight, the transaction being completed at a rate of about \$215 a ton or more than \$30,000,000 in the aggregate.

Lake Boats Change Hands.—W. C. Richardson & Co. has added two more boats to its fleet, having purchased the steamer Frontenac and the barge Chattanooga from the Grand Island Steamship Co. The boats which have been operated by the Cleveland Cliffs Iron Co. have been turned over to the new owners. The Frontenac has a carrying capacity of about 3,200 tons and a keel length of 270 feet, a 40-foot beam, and is 24 feet deep. The Chattanooga is a wooden vessel with a 308-foot keel, 45-foot beam, and is about 4,000 tons gross.

B. C. Wood Products Export.—The export of shingles from the port of Vancouver to the United States in 1916 amounted to \$4,050,978, as against \$3,790,763 in 1915. Pulp also showed a large increase, the figures being \$554,397 in 1916, as against \$203,620 in the previous year. There was a drop in shingle bolts from \$15,195 to \$7,522. Logs showed a falling off from \$895,344 to \$579,218, and lumber, which includes ceiling, flooring, siding and ties, amounted to \$1,127,888 in 1916, against \$1,711,498. Paper increased to \$1,209,466, compared with \$1,002,557 in 1915. The total value of the wood products was \$7,666,461, compared with \$7,698,707 in 1915.

Mineral Resources Near Kingston.—Mineral resources of the Kingston district in Ontario are attracting increased attention, according to United States Consul Felix S. S. Johnson. The iron mine near Trenton, closed for many years, has been reopened and large shipments of ore made to the United States. This ore is mixed with other ore in the manufacture of steel. Export figures for the district show several thousand tons shipped. Large bodies of mica have been discovered north of Kingston recently. American capital is interested in several properties in the Sydenham district. Since the war began there has been a greater demand for Canadian mica than heretofore.

Business With Russia.—Owing to the special importance, at the present time of establishing commercial connections, on a firm basis, between the allied countries, with the object of ousting German

intervention and competition, the Russo-British Chamber of Commerce at Petrograd requests all British firms wishing to trade with Russia now or after the war to send their catalogues and price lists (not less than 10 copies) to the Chamber. The catalogues in question will be placed in the special library of the Chamber, and will be distributed to Russian merchants interested in the development of their trade connections with England. They are to be addressed to the Russo-British Chamber of Commerce, 4 Gorochovaia, Petrograd, Russia.

Lake Steamers for Ocean Trade.—Advices from Cleveland, Ohio, state that, according to the Shipping Act, American ships cannot be transferred to foreign registry without approval of the Shipping Board, but, if that can be secured, a number of lake steamers will be sold for salt water service before opening of navigation and will be placed under British registry. Options have been taken by unnamed Canadian interests on eight package freight steamers and, if the Shipping Board approves, sales may be closed at an early date, as the boats will have to be cut in two so as to pass through the Welland Canal. It is understood a good price has been offered for package freighters.

Russian Buyers Arrive.—A Russian purchasing commission has arrived in Ottawa and opened offices to secure supplies for Russia, both for military forces and the civil population. It is expected that Russian orders placed in Canada this year will aggregate millions. For some months the Canadian Government has felt that of Russian orders being placed in America a great proportion was not reaching Canada. Sir Robert Borden made representations to the British authorities and they pressed the claims of Canada on the Russian Government. After many months negotiating, the result is an imperial Russian purchasing commission for Canada with authority equal and similar to the corresponding body in the United States.

Hurts Canadian Trade.—Canadian manufacturers, importers and exporters are being hit rather hard by the trade restrictions of the British Government which the war developments has made necessary. Nine-tenths of the mail in the Trade and Commerce Department these days refers to the prohibition or restrictive methods in force, and while they are not new, many firms apparently are only awakening to the fact that such regulations have been imposed. The restricted import of machinery and machinery parts, and the export of wood and paper, give rise to the greater number of complaints. All the department can do is handle each case through the High Commissioner, but, generally speaking, the regulations are being adhered to.

Canadian Firm's Activities in Latin-America.—Jenkins Bros., Ltd., Montreal, the well-known manufacturers of brass and iron body valves of every description, have more securely entrenched themselves in the leading markets of

South America, having lately sent a special representative to look over the situation with a view to extending trade relations there. The territory having been traversed successfully, a follow-up system has been inaugurated whereby their products will be given all publicity possible. In this connection they have issued new catalogues, one No. S-S., printed in the Spanish language, and another, No. S-P., in Portuguese, both of which fully describe and illustrate valves and mechanical rubber goods suitable for the requirements of up-to-date power and industrial plants, mines and office buildings.

Train Returned Soldiers at McGill.—The Faculty of Applied Science of McGill University, Montreal, has, subject to one week's notice, agreed to place its workshops and drafting rooms at the disposition of the Military Hospitals Commission, for the training of those returned soldiers who, through their loyalty to their King and country, are no longer fitted to follow their former occupations, and must be trained into other occupations that they may be self-supporting. The work has, to the present, been carried on at the Grey Nunnery with success, but so great has become the demands on the Military Hospitals Commission that other classes and other schools must be had. The new hospital, formerly the Loyola College, on Drummond Street, will be available shortly, and, besides the McGill workshops, the Technical School, on Sherbrooke Street, will also be utilized to carry on the work of re-educating the convalescent soldiers.

The Carbon & Alloy Steels Co., Ltd., has obtained a Dominion charter, with an authorized capital of \$1,500,000, and will erect furnaces and a foundry plant in Hamilton, Ont., for the manufacture of steel castings, ingots, etc., by the Moffat electric process. The company will also take over the Moffat-Irving Steel Works of Toronto, which will be moved to Hamilton and added to the new plant. Plans have been prepared by Prack & Perrine for buildings that will cost about \$100,000. The main building will be 60 ft. wide and 400 ft. long, while subsidiary buildings will cover an equal area. Another \$200,000 will be spent on furnaces, electrical equipment, conveyors, cranes, compressors, and general machinery. The plant when fully equipped will give employment to about 250 men, and will have a gross capacity of 32 tons of molten steel per 24 hours. The incorporators are: J. B. O'Brien, K.C., president, Moffat-Irving Steel Works, Toronto; H. J. Waddie, Esq., President, Canadian Drawn Steel Co., Hamilton; J. W. Moffat, Esq., vice-president, Moffat-Irving Steel Works, Toronto; John G. Gauld, K.C., Gauld, Langs & Creskwaite, Hamilton; W. E. Vallance, Esq., late of Wood, Vallance & Co., Hamilton.

CATALOGUES

Sight Feed Lubricators.—Two bulletins have been issued by the Penberthy Injector Co., Windsor, Ont., describing

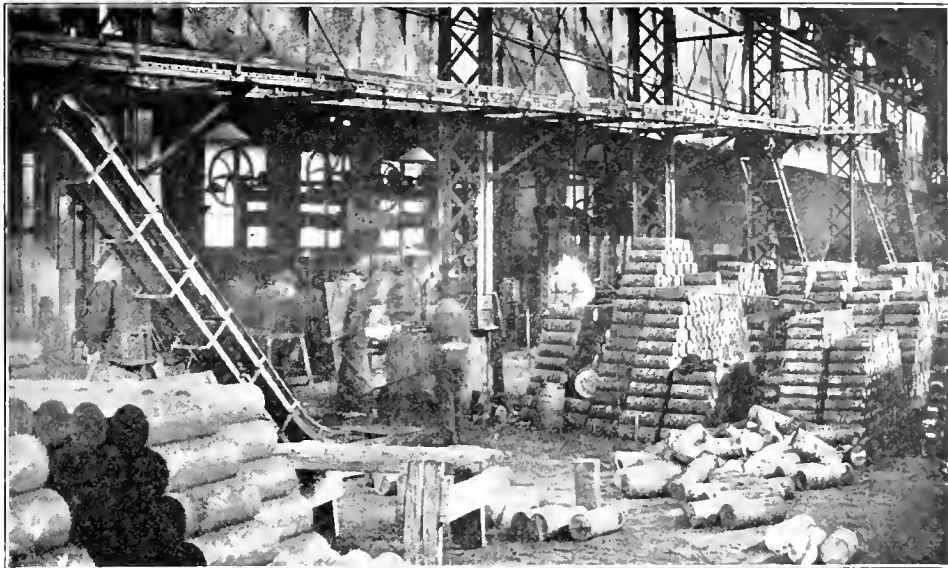

Steel Shell Forgings or Billets of any size or weight will move any distance or about curves upon our specially constructed Gravity Carriers and Incline or Horizontal power devices. No labor required.

Canadian Mathews Gravity Carrier Co., Toronto, Ont.

We are qualified Tool, Die, Jig, Gauge and Fixture Makers.
 WRITE US.
 Windsor Machine & Tool Works.
 WINDSOR, ONT.

MORTON MANUFACTURING CO.
 PORTABLE PLANERS
 DRAW CUT SHAPERS
 SPECIAL DRAW CUT R R SHAPERS
 FINISHED MACHINE KEYS
 STATIONARY & PORTABLE KEY WAY CUTTERS
 SPECIAL LOCOMOTIVE CYLINDER PLANERS
 OFFICE AND WORKS: MUSKEGON HEIGHTS USA

OVENS
 Enamelling and Varnishing Ovens heated by Gas, Electricity, Steam or Coal.
 Write for Booklet.
 Brantford Oven & Rack Co., Ltd.
 Brantford, Canada.

Forgings Cranks, Connecting-Rods, Valves and any other special work
 MACHINE HANDLE FORGINGS
 Blue finish, ready for use.
 Write for prices to
 ST. CLAIR BROS., Galt, Ont., Can.

H&M Thermometers

A Visit To Our Plant By You

To Investigate OUR Facilities, will set aside any question as to our preminence in the field of Industrial Thermometry. You can then see for yourself the processes and system of inspection and tests that have made *Trees* the synonym for unsurpassed accuracy in the measurement of temperature.

We are specialists in the manufacture and design of H&M Type Thermometers, *Trees* Recording and Indicating Thermometers, Automatic Temperature and Pressure Regulators, Mercury Vacuum, and Absolute Pressure Gauges, Engraved Stem Thermometers, Hydrometers, Hygrometers, Thermo-Electric and Radiation Pyrometers, and many other measuring instruments used in the industrial, chemical and metallurgical arts.



The H & M Division
Taylor Instrument Companies
 Rochester, N.Y.

201 Royal Bank Bldg., Toronto



PATENT ATTORNEYS

BABCOCK & SONS

ESTAB. 1877

PATENTS-TRADE MARK-DESIGNS
 IN ALL COUNTRIES

 Book "Patent Protection"—free. Master
 of Patent Laws, Formerly Patent Office
 Examiner.

 99 St. James St., - Montreal, Que.
 Branches: Ottawa, Washington.

RESEARCH BUREAU

 REPORTS BY EXPERTS ON SCIENTIFIC, "TECH-
 NICAL AND INDUSTRIAL DEVELOPMENT.

SPECIAL RESEARCHES ARRANGED.

PATENTS, TRADE MARKS, ETC.

HANBURY A. BUDDEN

CABLE ADDRESS

712 DRUMMOND BLDG., MONTREAL

"BREVET"

PATENTS

Fetherstonhaugh & Co.
 Patent Solicitors. Head Office,
 Royal Bank Bldg., Toronto,
 Ottawa Office, 5 Elgin St.
 Send for our Plain Practical
 Pointers. Copy of National
 Progress, in which our patents
 are advertised, mailed free.

PATENTS TRADEMARKS AND DESIGNS

PROCURED IN ALL COUNTRIES

 Special Attention given to Patent Litigation
 Pamphlet sent free on application.

RIDOUT & MAYBEE 59 Yonge Street
 TORONTO, CANADA

SPECIAL MACHINERY

 GAUGES, FIXTURES, DIES
 AND
 PRECISION TOOLS

 WE HAVE THE
 MOST MODERN
 EQUIPMENT
 TO HANDLE
 ANY CLASS OF WORK

 CANADIAN DISTRIBUTORS FOR THE
**ALBANY PATENT ROTARY
 PUMP**
Albany Pump Co.

 16 Pearl St., TORONTO, Canada
 Phone Ad. 2511 A. W. Bennet, Manager

and illustrating the "Peerless" and new "Polar" sight feed steam lubricators.

Ball Bearings.—The Rochester Ball Bearing Co., Inc., Rochester, N.Y., have issued Bulletin No. 10, which is a descriptive price list covering the "Rochester" ball thrust bearings. The bulletin contains a description of the bearings and tables giving the principal dimensions and prices.

Automatic Plate Valves.—The Mesta Machinery Co., Pittsburgh, Pa., are distributing a new bulletin dealing with the Mesta automatic plate valves (Iversen Patent). The principal features and general construction of the Mesta valve are described in detail accompanied by illustrations. The suitability of this valve for use in air and gas compressors and blowing engines is mentioned in this bulletin.

Water Heaters.—The Alberger multi-head water heater for hotels, office buildings and factories, is described in a Bulletin No. 201 recently issued by the Alberger Heater Co., Buffalo, N.Y. The principal constructional features of the multi-head heater and their advantages are described fully, special reference being made to the method used in the heater to accommodate unequal expansions. The bulletin is illustrated.

Drilling Machines.—The Rockford Drilling Machine Co., Rockford, Ill., have issued a series of circulars in a loose leaf binder featuring an interesting line of Rockford drilling machines, ranging from sensitive drills to gang drills. The various types are illustrated, accompanied by a brief specification covering the principal dimensions. Other lines illustrated and described include the "Rockford" Hi-Speed auxiliary heads, horizontal drilling, boring and tapping machines, and tool grinders.

Galt Sprinkler Stoker.—The Galt Foundry Co., Galt, Ont., have issued an attractive catalogue dealing with the economic and smokeless burning of coal, including lignite, and at the same time featuring the Galt sprinkler stoker. A full description is given of this type of stoker, and its principal feature dealt with in detail, accompanied by numerous illustrations showing the construction and application to various types of boiler. The concluding pages contain some useful engineering data covering evaporation formulae, heat values of coal, feed water calculations, miscellaneous tables, etc. The catalogue also contains instructions for reading the slide rule, accompanied by diagrams. The McNaughton rocking sectional grate bar is also described and illustrated. The catalogue is well gotten up, being printed on coated paper, with exceptionally clear half-tones.

Realism in Calendar Art.—Armstrong, Whitworth, of Canada, Ltd., have had prepared for distribution to their clients a Wall Calendar which is at once realistic of a departmental activity of their plant at Longueuil, Que., and a highly creditable example of the art of calendar production. We understand that

only a limited number of the calendars are now available, but these will be mailed on request while the supply lasts. The calendar, which has a monthly "tear-off" slip covering each month of 1917, measures 14 ins. by 21 ins. A facsimile on a reduced scale of the pictorial feature of the calendar will appear in the "Armstrong, Whitworth" advertisement on the outside front cover of our March 8 issue.

Black Sheets.—An interesting booklet has recently been published by the American Sheet & Tin Plate Co., Pittsburgh, Pa., entitled "Black Sheets and Special Sheets." The several products are briefly described in conjunction with the trade designations, covering numerous grades of varying degrees of finish, tenacity and other distinctive qualities. For the convenience of the trade, such finishes as are of special qualifications have been grouped under the industry responsible for their origin. The booklet contains some useful tables, including U. S. standard gauge, thicknesses of steel sheets, and a bundling table of black sheets, etc. An interesting feature of the booklet is a diagram of the manufacture of steel as used for sheet and tin mill products.

Bellevue Furnaces.—The Bellevue Industrial Furnace Co., Detroit, Mich., have issued an attractive catalogue No. 3, describing and illustrating an interesting line of stock sizes of "Bellevue" furnaces and accessories designed to supply standard equipment for all methods of metal heat treating. The principal features of the various types of furnace, which are adapted for use with oil or gas, are dealt with and the essential dimensions given for each size. Some of the uses to which these furnaces can be put include, melting all kinds of metals, brazing, ease-hardening, forging, heat-treating tempering, rivet heating, tilting and tool furnaces, etc. The catalogue contains 68 pages with index and is fully illustrated.

BOOK REVIEW

"The Tractive Resistance on Curves of a 28-Ton Electric Car".—The subject has been investigated by the Railway Department of the Engineering Experiment Station of the University of Illinois. The results which are set forth in bulletin No. 92 of the station establish, for this car, the relation between curve resistance and speed, and between curve resistance and rate of curvature; the ratio in both cases is direct. Tests were conducted upon each of seven curves on the lines of the Illinois Traction System, the curvature of which varied from 2 to 14½ degrees. Test runs were also made over tangent track adjacent to the curves. The tests were made by Professor E. C. Schmidt, and H. H. Dunn. Copies of this Bulletin may be obtained gratis by writing W. F. M. Goss, Director of the Engineering Experiment Station, Urbana, Ill.

CANADIAN MACHINERY

AND MANUFACTURING NEWS

A weekly newspaper devoted to the machinery and manufacturing interests.

Vol. XVII.

TORONTO, MARCH 8, 1917

No. 10

EDITORIAL CONTENTS

Machining 9.2 ins. H.E. Shell in a Structural Steel Plant	195-201
Shop Inspection Routine in 18-pdr. H.E. Shell Production	202-206
General	206
<i>An American Confession.</i>	
Female Labor on 8-ins. High Explosive Shell Machining	207-214
General	214
<i>British Shrapnel Manufacture in Canada...Mis-use of Gauges...Won't Leave United States ...Abrasive Materials.</i>	
Crude Oil Installation for Shell Furnace	215-216
General	216
<i>Base Plate Chuck for 4.5 ins. H. E. Shell...Don'ts for Shell Operators ... Australian Steel for Imperial Government.</i>	
Manufacturing Brass Cartridge Cases for Shrapnel and High Explosive Shell	217-223
General	223-226
<i>Conveyors in Shell Forging Plants...No More 18 ss Rifles...New British Policy Sound for Canada...Treating High-Speed Steel...Official Price of Aluminum.</i>	
8-ins. H.E. Shell Production by Public Utility Corporation	227-232
General	232
<i>Women Employees in Railroad Shops...Women's Section of Imperial Munitions Board ... Grinders on Machine Tools.</i>	
Percussion Fuse Production With Female Labor Prominent	233-239
General	239-240
<i>Britain's Export Trade...Engineers Organize for National Service...Our Mineral and Forest Resources...Questions and Answers Relating to Munitions.</i>	
Shrapnel Shell Manufacture Featured by an Installation of Special Equipment	241-246
Editorial	247
<i>Our Present Effort a Future Asset...Development of Shipbuilding and Marine Engineering.</i>	
Selected Market Quotations	248-249
The General Market Conditions and Tenendency	249
<i>Summary...Montreal Letter...Toronto Letter... Latin-American Trade Possibilities.</i>	
Industrial and Construction News (Advertising Section)	157-162

THE MACLEAN PUBLISHING COMPANY, LIMITED

JOHN BAYNE MACLEAN, Pres. H. T. HUNTER, Vice-pres. H. V. TYRRELL, Gen. Man.

Publishers of Hardware and Metal, The Financial Post, MacLean's Magazine, Farmer's Magazine, Canadian Grocer, Dry Goods Review, Men's Wear Review, Printer and Publisher, Bookseller and Stationer, Canadian Machinery and Manufacturing News, The Power House, The Sanitary Engineer, Canadian Poundryman, Marine Engineering of Canada.

Cable Address: Macpubco, Toronto; Atabek, London, Eng.

ESTABLISHED 1887.

CANADIAN MACHINERY

AND MANUFACTURING NEWS

PETER BAIN, M.E., Editor. B. G. NEWTON, Manager.
Associate Editors: A. G. WEBSTER, J. M. WILSON, J. H. RODGERS

CHIEF OFFICES:

CANADA—Montreal, 701-702 Eastern Townships Building; Toronto, 143-153 University Ave., Telephone Main 7324; Winnipeg, 22 Royal Bank Building, Telephone Garry 2313.

GREAT BRITAIN—LONDON, The MacLean Company of Great Britain, Limited, 88 Fleet Street, E.C., E. J. Dodd, Director. Telephone Central 12960. Cable Address: Atabek, London, England.

UNITED STATES—New York, R. B. Huestis, 115 Broadway, N.Y., Telephone Rector 8971; Boston, C. I. Morton, Room, 733, Old South Building, Telephone Main 1204. A. H. Byrne, 1101 5-6-7 Fort Dearborn Bldg., 105 W. Monroe St., Chicago, Telephone Randolph 3231.

SUBSCRIPTION PRICE—Canada, Great Britain, South Africa and the West Indies, \$3.00 a year; United States, \$3.50 a year; other countries, \$4.00 a year; Single Copies, 15 cents. Invariably in advance.

"New York's Greatest Clearing House — New York's Lowest Prices — J. J. McCABE"

16-ft. Set of Bending Rolls

Built by "Niles-Bement-Pond Co." (Bement Works)

16 ft. 2 in. between housings, for shaping plates as well as bending to a full circle.

Four (4) Rolls—each 20 in. diam.

Capacity for handling plates up to 1½ in. thick.

Drop-end housing.

Two pair of "Payne" Reversing Engines. Used only off and on in one of the largest and best equipped plants in the country, and will give you every satisfaction of a new machine you'd have to wait several months for. Approximate weight, 250,000 lbs.

To save handling and shipment to our warehouses, it will be disposed of immediately at half the new cost.

UPRIGHT BORING MILLS

80 in. Swing, Wm. Sellers & Co., 1 Hd.
60 in. Swing, Rogers, 2 Hds., Motor-dr.
40 in. Swing, Colburn, 2 Hds., Sp-box.
36 in. Swing, Brown & Sharpe, Tur. Hd.

HORIZONTAL BORING AND DRILLING MACHINE.

3—15 16 in. bar "Bisso" style" Knee type, Adjustable table, outside yoke support

PLANERS

48" x 48" x 12' Niles, 2 Hds.
42" x 42" x 14' Pond, 2 Hds., Motor-dr.
42" x 42" x 10' Putnam, 3 Hds.
40" x 40" x 10' Putnam, 2 Hds., Motor.
40" x 40" x 12' Putnam, 1 Hd.
36" x 36" x 11½' Sellers, 1 Hd.
36" x 36" x 8' Putnam, 1 Hd.
32" x 32" x 8' (2) Pond, 2 Hds.
26" x 26" x 4' Putnam, 1 Hd.
24" x 24" x 6' Sellers, 1 Hd.

PLATE PLANER.

14-ft. for edge planing, Wm. Sellers Co.

"PLANER TYPE"

SLAB MILLING MACHINES.

36" x 22" x 8' Newton, Vert. Hd. only.
24" x 24" x 12' Bement-M. Horiz. spindle.
24" x 24" x 8' Bement-M. Horiz. spindle.
24" x 24" x 6' (2) Ingersoll, Hor. spindle.

OTHER MILLING MACHINES.

No. 2 Cincinnati, Plain.
60" Vertical, Bement-Miles.
42" Vertical, Bement-Miles.
Lincoln type (11) Table 27" x 6".
Lincoln type, Table 39" x 7".

RADIAL DRILLS.

7-ft. Arm, Motor-driven, Niles.
7-ft. Arm, Heavy, Pond Mch. T. Co.
5-ft. Arm, Heavy, Pond Mch. T. Co.
5-ft. Arm, Half-Univ., Niles T. Wks.
5-ft. Arm, Heavy, Bement-Miles.
4-ft. Arm (2) Bickford, Motor-dr.
2½-ft. Arm, Gang Co., Round Table.
2½-ft. Arm, heavy, Bement-Miles.

NEW RADIAL DRILLS.

2—2½-ft. Arm, Speed-box.
2—3½-ft. Arm, Speed-box.
3—4-ft. Arm, Speed-box.

OTHER DRILLS.

18-spindle, Baush, capacity 17 holes.
36 in. Swing, (2) Fouts Burt, Heavy duty.
20-in. Swing, Wheel and Lever (New).

SHAPERS

28-in. stroke, Triple-grd., Smith & M.
20-in. stroke (2) Back-grd., Gould & E.
12-in. stroke Traveling Hd. Sellers.

NEW SHAPERS.

2—12-in. stroke, Plain.
3—16-in. stroke, Plain.
4—20-in. stroke, Back-grd.
2—25-in. stroke, Back-grd.
2—28-in. stroke, Speed box.
5—32-in. stroke, Speed-box.

SLOTTERS.

9-in. stroke, Bement.
10-in. stroke, Newton.
10-in. stroke, Sellers.
12-in. stroke, Sellers.
12-in. stroke, Bement.
12-in. stroke, Betts.
18-in. stroke, Bement-Miles.

ENGINE LATHES.

Long Beds.

62-in. Swing, 24-ft. bed, New Haven, Triple-grd.
60-in. Swing, 20-ft. bed, New Haven, Triple-grd., Chuck-jaws.
56-in. Swing, 28-ft. bed, Putnam Mach. Co., Triple-grd.
28-in. Swing, 36-ft. bed, Fay & Scott, Heavy.
28-in. Swing, 50-ft. bed, Pond style, Taper att.

OTHER LATHES

36-in. Swing, 16-ft. bed, Putnam Mach. Co.
26-48-in. Swing, 14-ft. bed, McCabe, Double-spindle, Motor-drive, Geared Plate.
26-48-in. Swing, 10-ft. bed, McCabe, Double-spindle.
24-in. Swing, 15-ft. bed, Bement, heavy.
20-in. Swing, 14-ft. bed, Hamilton, Quick-change.
18-in. Swing, 12-ft. bed, Porter, arr. for Motor-drive.
18-in. Swing, 12-ft. bed, Schumacher & Beye, Cab. legs.
18-in. Swing, 10-ft. bed, Draper, Hol. spindle.
18-in. Swing, 8-ft. bed, LeBlond, Hol. spindle.
16-in. Swing, 6-ft. bed, LeBlond, Hol. spindle.
15-in. Swing, 6-ft. bed, Sebastian.

NEW LATHES.

2—16 in. Swing, 6-ft. bed, Single Back-grd.
3—18-in. Swing, 8-ft. bed, 3-step Cone, Dble. Bk.-grd.
1—21-in. Swing, 8-ft. bed, 3-step Cone, Dble. Bk.-grd.
1—24-in. Swing, 12-ft. bed, 3-step Cone, Dble. Bk.-grd.
3—24-in. Swing, 14-ft. bed, 3-step Cone, Dble. Bk.-grd.
3—24-in. Swing, 16-ft. bed, 3-step Cone, Dble. Bk.-grd.

NEW McCABE LATHES.

"2-in-1" "DOUBLE SPINDLE" Latest Heavy Pattern, 26-48-in. Swing, 12-ft. beds—6 ft. between Centers, complete equipment for two Lathes, standing on the floor space of one.

Swing over bed on Upper Triple-gear spindle, 18 in.
Swing over Carriage on Upper Triple-gear spindle, 40 in.
Swing over bed on Lower Back-gear spindle, 26 in.
Swing over Carriage on Lower Back-gear spindle, 16 in.
Any length of bed up to 40 ft. can be furnished.

STEEL TIRE LATHE.

42 in. Swing, Double-head, cuts both wheels at the same operation, Bement-Miles.

TURRET LATHES.

21-in. Swing, Gap style, Gisholt.
20-in. Swing (2), Full-automatic, Potter & Johnston.
2 x 24 Jones & Lamson, Sliding-head, arranged for M. lat.
2 x 24 Jones & Lamson, Sliding-head, C-shaft drive.
Another 16-ft. set of

BENDING ROLLS.

Built by "Hilles & Jones Co.," 16 ft. 2 in. between housings, engine-driven, with engines, drop-end housing.
Three (3) Rolls in "pyramid" form, Top Roll 20 in. diam. Lower rolls 14 in. diam.
Capacity for handling up to ¾-in. plate.
Still set up in prominent plant where used.

STRAIGHTENING ROLLS.

Built by "Hilles & Jones Co.," 7 ft. 2 in. between Housings, Six Rolls in set, each 10 in. diam.

PUNCHES AND SHEARS.

60" gap, Horiz. cap'y 1½" thru 1¼" Bement-Miles.
36" gap, heavy, Wm. Sellers & Co.
14" gap, heavy, Cockburn.
Rotary Splitting Shears, Lenox

RIVETERS.

10 ft. Wm. Sellers Co., Steam-driven.
5-ft. 6-in. Sellers, Steam-driven.

STEAM HAMMERS.

1—300-lb. Miles, Single frame.
1—700-lb. Bement-Miles, Double frame.
1—900-lb. Morgan, Double frame.
1—2700-lb. Bement-Miles, Single frame.
1—4500-lb. Miles, Double frame.

DROP AND HELVE HAMMERS.

1200-lb. Miner & Peck, Drop.
900-lb. Williams & White, Drop.
50-lb. Bradley (2) Helve.

MISCELLANEOUS.

36-in. Automatic Gear Cutter, Spur and Bevel, Gould & Eberhardt.
36-in. Automatic Gear Cutter, Spur, Eberhardt, Double-end Cutting-off and Centering Machine, 9" Niles.
150-ton Hydraulic Wheel Press, with Double Pump.
Cold Saw, capacity for cutting 5-in. round, Lea-Simplex.
30-in. stroke, Slotter and Combination Key-seater.
2½-in. Bolt Cutter, Acme.
2 in. Bolt Cutter, Detrick & Harvey, Patent Die-head.
2-in. Bolt Cutter, Acme, Double-head.
1½-in. Bolt Cutter, Putnam.
Water Tool Grinder, Wheel 24 x 4.
Boring-bar 4¾-in. diam., 8' long.

YOU CAN ESCAPE the delay, waiting several months for new machines, by investigating these High-grade Tools for immediate shipment.

J. J. McCABE - 149 Broadway, New York

Mention this paper when writing advertisers. It will identify the proposition about which you require information.



HIGH EXPLOSIVE SHELL MANUFACTURE

Machining 9.2 ins. H. E. Shell in a Structural Steel Plant

Staff Article

The success that has attended shell-making in Canada has been unrestricted in the sense that neither size nor type of shell, nor their accessories, have proved themselves in the nature of stumbling blocks to any extent, and that where difficulty has been experienced, it has been overcome quite promptly and permanently. From the known variety of plant engaged in munitions production, such a state of affairs, is, to say the least, highly satisfactory.

MACHINING the 9.2 inch high explosive shell is, in many respects, similar to that on the smaller sizes; as a matter of fact, certain details, such as nose operations, are more or less identical. However, owing to the increased weight and dimensions, the methods of achieving the desired results are such as to call forth the best in individual ingenuity and necessitate, as well, high standard plant equipment. On account of the wide range of engineering ability and experience that has been drawn upon

and furnished unreservedly for the work, together with the local color that distinguishes each individual plant, the methods and devices adopted

tion of shell—general or in detail—is seldom the same in any two shops. The plant from which the accompanying data were obtained has only been producing the 9.2 inch shell for a very short period; it is, therefore, only of recent date that they have attained to capacity production. Owing to inability to store the rough forgings under cover, the shells as first received are arranged in large piles in the yard crane runway, the crane proving very serviceable in unloading from the cars. The forgings

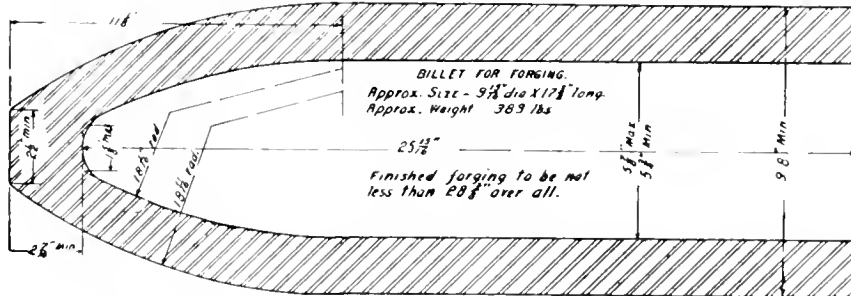

APPROXIMATE FORGING SIZES OF 9.2 INCH HOWITZER SHELL.

and employed for specific operations are so varied, although of perhaps equal efficiency, that the produc-

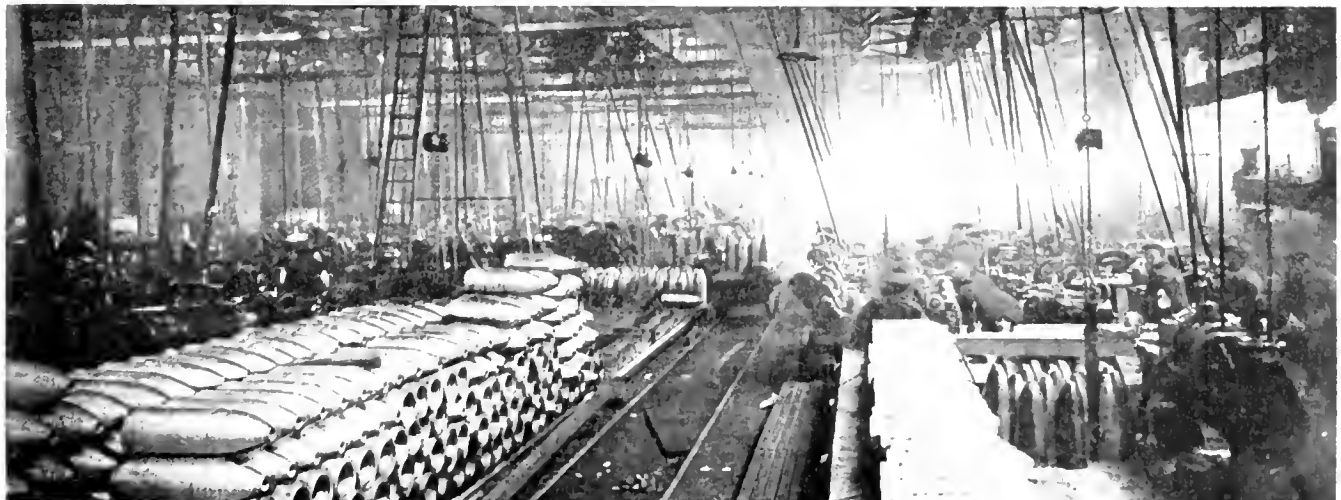

GENERAL VIEW OF SHOP LAYOUT FOR MACHINING THE 9.2 INCH HIGH EXPLOSIVE SHELL.

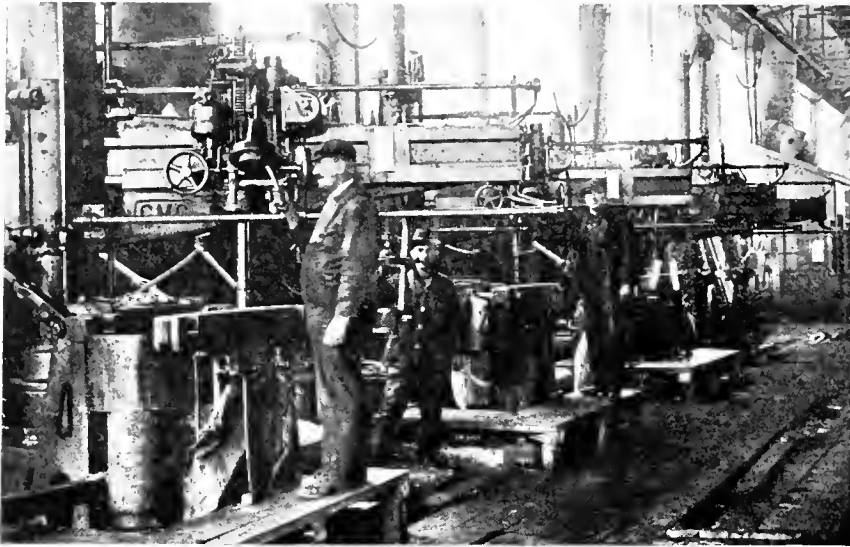

FIG. 1. BATTERY OF FOUR 6 FT. "C.M.C." RADIAL DRILLS OPERATING ON SHELL NOSES.

are piled in rows having distinct heat numbers, and, when required, are rolled on slightly graded wooden runways through openings in the wall, entering the machine shop at a point adjacent to the radial drills that perform the first operation, that of rough drilling the nose. It might be here stated that these openings in the walls are somewhat

larger than the shells and are covered with stiff canvas that allow the forging to enter and then fall back to close the aperture. This method of delivery from the outer yard to the shop not only provides a convenient means of handling the shells but does away with the opening and closing of doors, which in very severe weather is not greatly appreciated by the nearby workmen.

Drilling and Facing the Nose

The rough forging is approximately 30 inches long and 10 inches in diameter, and, as just stated, the first operation is drilling the hole in the nose. This is accomplished in five-6 ft. radial C.M.C.

and by means of an air hoist, with a lift of about 40 inches, is raised and placed over a vertical post secured to the center of the drill fixture, which in turn is firmly bolted to the base plate of the machine. The jig is of the duplex type, which permits the placing or removal of one shell while the tools are working on the other. A sketch of the central post for chucking the forging is shown in Fig. 2. This is of the pneumatic type, the operating cylinder being located at the base of the post. When the rough forging has been dropped in place, the inside profile rests upon the three point steel piece A, which is screwed to the upper end; the small plug B being driven into the top to prevent the cuttings from dropping into and injuring the interior mechanism. The air is allowed to enter the opening K, thus depressing the piston L, which is secured to the wedge block F by means of the rod J, which passes through the stuffing box I. By the downward movement of the wedge, the three jaws G are forced out to grip the inner surface of the shell near the base, and are released by means of the heavy flat spring H. The coiled spring E acts as a cushion when the wedge is pushed upwards. Two small holes are drilled in the post to allow the air to escape freely. The base is sealed by the disc N, held in position by the screws shown.

Following the setting of the shell, the cross-bar which carries the central guide bushing is swung into position and locked by means of a slot at the front of the fixture. Flat twisted Celfor drills of 15/8 inches diameter are used

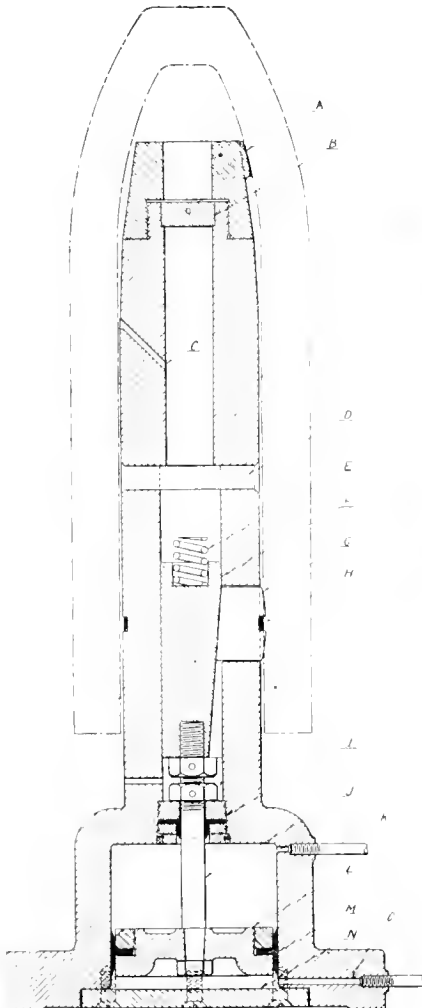

FIG. 2. AIR CHUCK FOR CENTERING WHILE DRILLING HOLE IN NOSE.

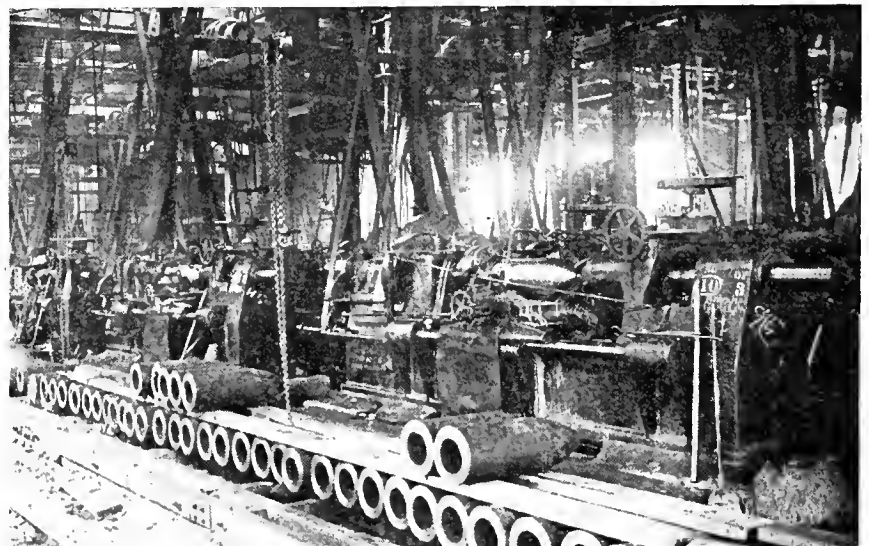

FIG. 3. ROUGH TURNING SHELL BODIES—"A.M.C." LATHES.

drills, fitted with special fixtures, and of ample weight and strength to eliminate all possibility of spring, thus insuring efficient accuracy when drilling. Fig. 1 shows a row of these drills working on this operation, each machine having a capacity of about 125 per day. When the shell is received from the outside, it is placed in a vertical position

to perform the drilling; the operation being aided by a copious supply of forced lubrication. The thickness of the metal at this point is about three inches, but the nose is faced off so that the depth is roughly 2 3/8 inches, as indicated in Diagram I of the Operation Chart. After facing, the shell is removed from the fixture, the hole ganged for

size, and the base marked for cutting off. The device used for this purpose consists of an inverted L shaped forging, carrying a 15/8 ins. pin to fit the hole in the nose, and at the lower end of the

able variation of .03 inches either way. In passing the shells from one operation to another, very little trucking is done, as a network of wooden runways are provided upon which the shells are

floating clutch collar placed over the bar just previous to inserting in position. To conveniently handle these bars, a small block and tackle is provided, this being supported upon a light overhead runway, as shown in Fig. 4. The roughing bar carries four staggered notched cutters for roughing out to 6.46 inches diameter. The finishing bar is then used to rebores to 6.5 inches diameter. In order to eliminate unnecessary work at a later stage, this plant adopted a method of setting the working depth of the bars on the interior profile that has proved very efficient. This was deemed advisable owing to the difference in tolerance between the nose depth and the overall length. A special bush, having the desired depth of nose metal, was placed over the centering plug in the face-plate, and, with no shell in position, the bars were forced against the bush and suitable feed stops adjusted to the proper length. By adhering to this method, it was found that increased accuracy could be better maintained. Each bar is provided with a special quick acting coupling for connecting the lubricating hose. It might be here stated that the cutting compound for all the heavy turning and boring machines is distributed to the various sections of the shop by means of a force pump, centrally located. Half ton Reading chain blocks are furnished to each of the heavy machines.

The profile cutters used in the boring bars are first sawn from bar stock, and afterwards cut to shape in a special fixture secured to the table of a small boring mill; the use of a parting tool permitting the surplus stock to be used for tipping tools. After drilling the clamping and dowel holes in the cutters, they are placed on a milling fixture, one on

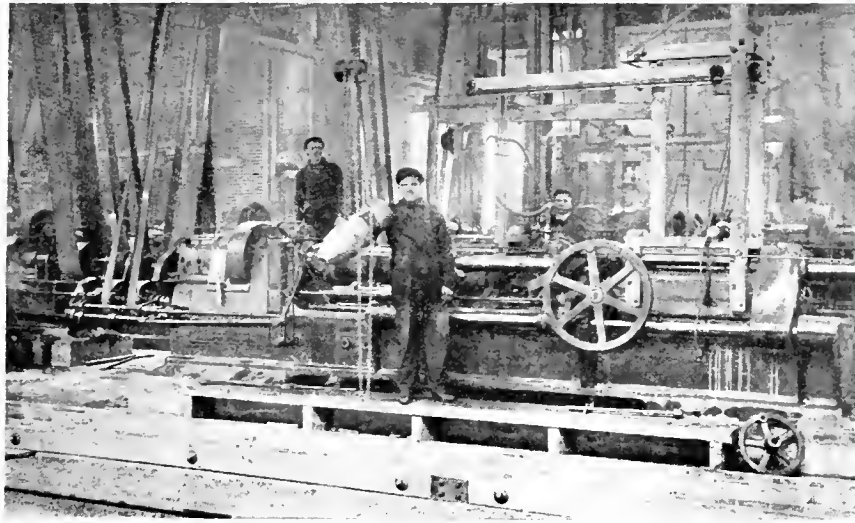

FIG. 4. "A.M.C." LATHES ON ROUGH AND FINISH BORING. ILLUSTRATION SHOWS SHELL BEING REMOVED FROM LATHE.

long arm a spring center punch is provided, by means of which several indents are made around the shell. As each shell leaves the first operation, a progress tag, secured to a piece of wire, is placed in its nose, this tag remaining with that particular shell as it passes from one machine to another.

Cut Off and Rough Turn

The second operation—cutting off the open end, is performed in five No. 12 Hall machines. The punch marks just spoken of indicate the length of the shell, which should be 27 1-16 inches, with an allowance of 1-32 inch above or below this dimension. For the rough turn operation, twenty Amalgamated Machinery Co. machines are employed, each having a capacity of over 30 shells per day. The entire length of the shell is turned at one setting; the shell being driven from the base end by means of a self acting three jaw (spring) arbor, a special split plug being placed in the nose end to receive the tail center. The contour of the nose is turned by the action of a solid point travelling on a cam placed at the rear of the lathe. Contact is maintained by means of suitable bell-crank levers having adjustable weights. Owing to the fact that accurate forging is next to impossible, all elementary machining operations are accomplished by gauging from the interior walls, thus making the work on the boring machines more uniform. It is obvious therefore, that in rough turning the outside, the cut may be irregular in proportion to the variation in wall thickness, but the average depth of cut will be from 1/4 to 1/2 inch. The profile radius is 18.4 inches, the tangential point being 10.72 inches from the nose end, while the parallel portion has a diameter of 9.32 inches, with an allow-

easily rolled from one position to another as required.

Rough and Finish Boring

Twenty special boring lathes of Amalgamated Machinery Co. make are operating on the rough and finish bore, both processes being accomplished at the one setting of the shell. Special chucks similar to that shown in Fig. 8, but longer, are used. The hole in the nose is placed over the pin secured in the center of the face-plate, while the outer end is held central by means of a three point clamp, hardened serrated jaws

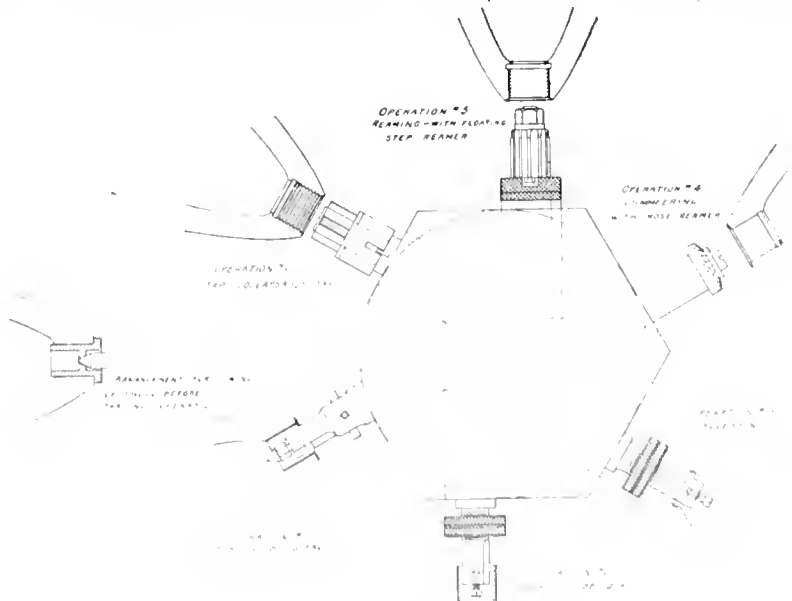

FIG. 5. NOSE BORING TURRET LAYOUT

being inserted to grip the shell. The cutter bars are held by means of a tapered shank to the heavy tail-stock spindle; the drive being obtained by a

either side of a master cam, and milled to the desired contour; a roller being located between the two cutters on the arbor. They are then hardened and

tempered, and finally ground to gauge on a special attachment fitted with an electric grinder, the arc movement being

step reamer to a diameter of 1,906 inches; the diameter below the recess being 1.825 inches. A Victor collapsible

shown shaded in the chart are the removed. Eleven Advance-Rumley machines are working on this operation, each having a capacity of about 90 shells per day.

Finish Turn and Profile

This operation is practically a duplication of the rough turning but involving greater accuracy. The method of forming the nose profile is different, inasmuch as the contour is derived by means of a radius arm in place of the stationary cam. Two tool posts are provided: the one operating on the parallel section being secured to the forward portion of the lathe saddle. A sketch of the arrangement is shown in Fig. 6. The radius arm A is an extension of the lower portion of the cross slide rest; the pin B, whose center is definitely set at a distance of 18.4 inches from the cutting tool M, being secured in a permanent position to the bracket C, the lower portion of which is rigidly bolted

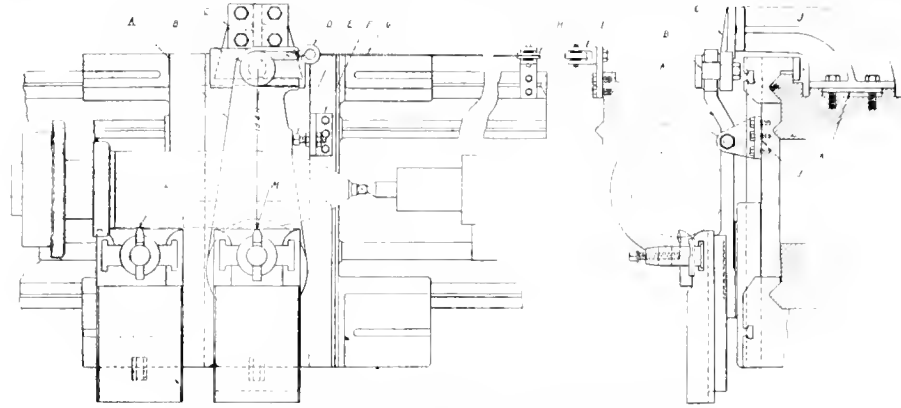

FIG. 6. LAYOUT OF FINISH TURNING DEVICE.

about 30 degrees and the radius 16 1/4 inches.

Machining the Nose

The sequence of operation at this stage is shown in Diagram V. of the Operation Chart, the tool layout being seen in the sketch Fig. 5. The different sections illustrate the progressive stages of turret operations. When placing the shell in position, a special bush is inserted in the nose for the purpose of obtaining proper alignment; this is seen to the extreme left of Fig. 5. The steady-head being adjusted, the bush is removed and the nose roughed out to 1.810 inches diameter, and the front faced. It is again bored to a diameter of 1.881 inches, following which a recess is formed, .175 inches wide at a distance from the nose of 1.8 inches, the maximum diameter being 2.008 inches. A rose reamer then faces the nose to an angle of 18 degrees. The hole is finally reamed with a floating

14 thread, R. H. tap completes the operation of machining the nose.

Through defective forging or subsequent machining, it is sometimes necessary to resort to the optional method of enlarging the nose to take a separate bushing. To prepare the shell nose for this bushing, the machining shown in the adjacent re-nosing operation sheet, re-nosing is necessary. Metal is cut from the face to a depth of .35 inch, and the bore enlarged to 2.393 inches, re-bored to 2.410 inches, and then tapped 14 threads per inch. When the bush is put in position, the portions

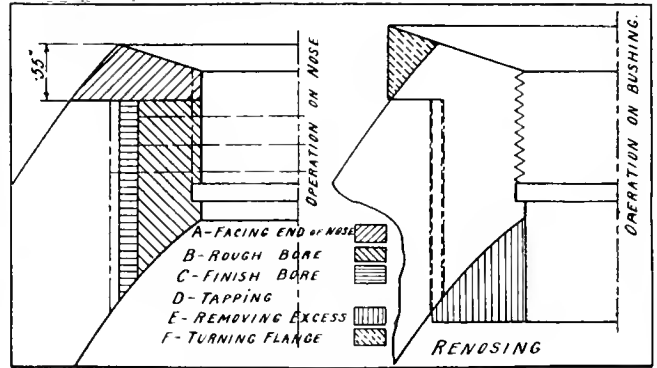

RE-NOSING OPERATION SHEET.

to the bed of the lathe. When operating on the profile (the cutting generally commencing at the nose), the radius arm is held firmly against the pin B by means of the cable G secured to the eyebolt D, the opposite end of the cable carrying a heavy weight. Secured to the saddle is the bracket F which carries the adjustable stop E which makes contact with the radius arm when the cutting tool is at the tangential point of the profile and parallel portion. As the saddle continues its forward movement, the tool M will follow in the path of the profile and parallel portion. The finished surface leaving no evidence of double tooling. The radius of the profile is the same as that on the rough turn, but the tangential point is located 10.62 inches from the nose. The finished outside diameter should be 9.155 inches, with a high and low tolerance of .01 inch. For about three inches at the base the diameter is reduced to 9.055 inches with the same limit allowance.

Wave and Groove for Copper Band

This operation is performed on eight Root & Van Dervoort special machines, each of which is provided with four tool turrets and a single post at the rear. The progress of the work is clearly shown in the Operation Chart, Diagram VII. By means of the rear tool the groove is sized for width of 2,565 inches,

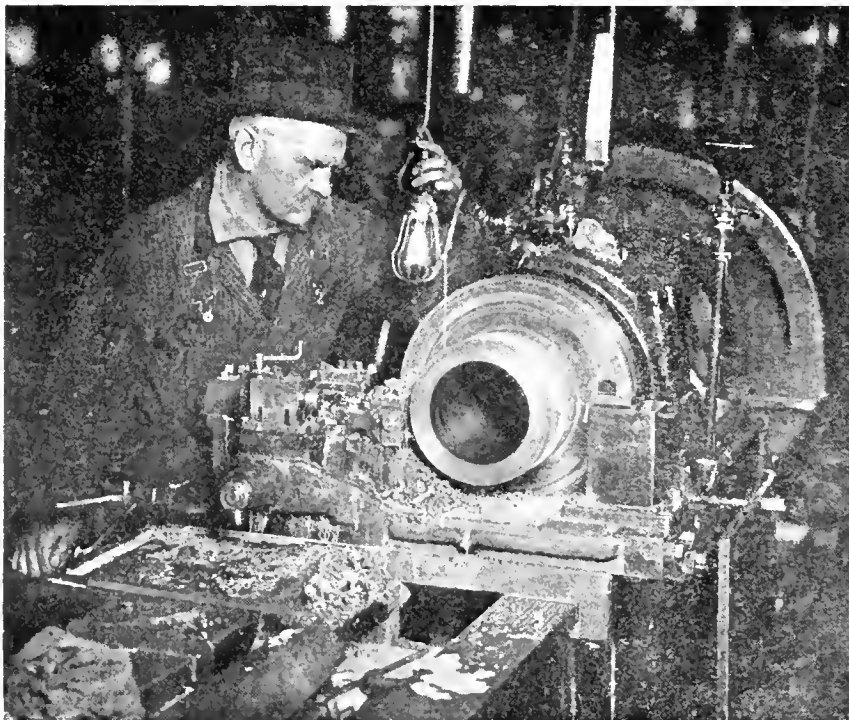

FIG. 7. WAVING AND GROOVING "R. & V." MACHINES.

the center being 24.42 inches from the nose of the shell. These tools cut to a diameter of 8.7 inches with an allow-

having an output of about 70 shells per day. As shown at the left of Fig. 8, the chuck is of the semi-enclosed type, the

high and low limit tolerance. The three component parts of the adjustable collet are shown in Fig. 9. The outer diameter of the ring A revolves in the babbitt bearing of the steady-head, while the inner conic surface conforms to that on the outer diameter of the split collet B which is adjusted to the shell size by the movement of the nut C.

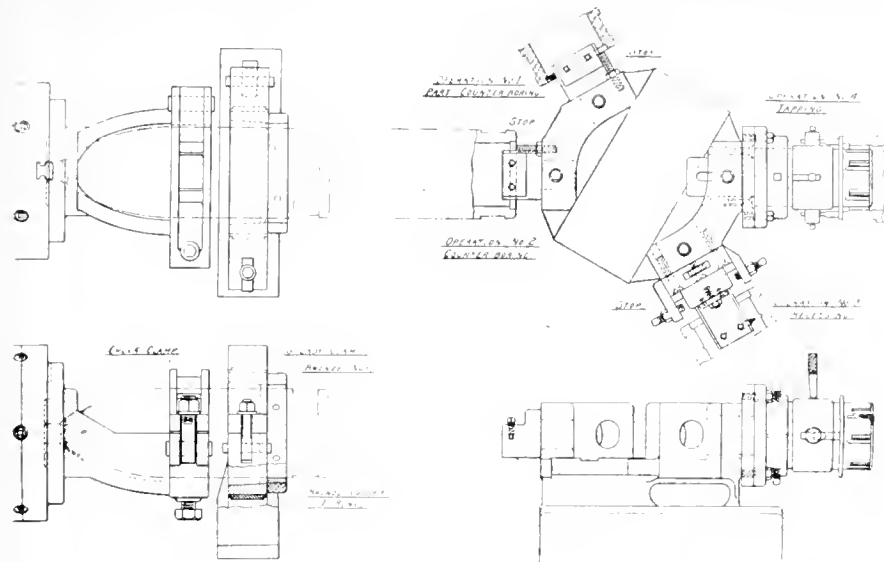

FIG. 8. LAYOUT OF TOOLING FOR BASE BORING AND TAPPING.

able variation either way of .02 inch. The gang tool in the turret then cuts to the same diameter, after which the remaining stock is swept out with a broad nosed tool. The undercutting is next performed, both tools advancing simultaneously at the desired angle by means of a small hand-operated worm and gear with pinion meshing in rack cut in the top of each tool. The waving is afterwards accomplished, the oscillation being obtained by a roller in contact with a cam on the chuck face. This operation is seen in Fig. 7.

Base Boring for Adapters

After the groove for the copper band has been cut, the shells are machined in the base to receive the adapters. Nine Steidle turret lathes fitted with special chucks and steady-heads are employed in this operation, each machine

clamp providing the necessary drive. This clamp is swung clear, while shell is being placed in or removed from the chuck. As indicated in the sketch, the nose is placed over a plug in the centre of the face-plate, while the outer end is supported in the steady-head. This steady-head is of special design, being fitted with an adjustable bronze collet bushing to allow for the slight variation that arises through the

The turret tool layout is shown in Fig. 8, the order of operations being indicated on Diagram VIII of the Operation Chart. The end is first faced to a distance of 1.12 inches from the back edge of the rifling band groove. The interior is then counterbored for a depth of .71 inch, and to a diameter of 6.99 inches, after which the recess is cut-in at a distance from the base of 2.28 inches to a diameter of 6.675 inches; this being the root diameter of the thread. The thread is then cut-in with a Murchey collapsible tap, oil being used as the cutting medium. The clamping bolt is eased off while tapping to relieve the tap from unnecessary strain.

Turning and Fitting Adapters

Following a preliminary Government

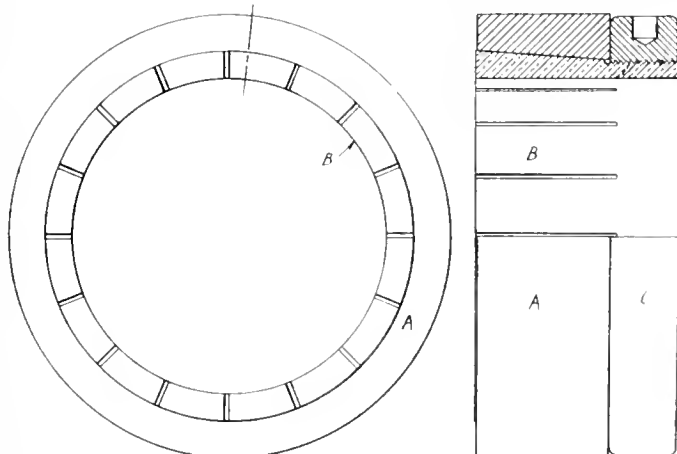

FIG. 9. STEADY HEAD BUSHING.

inspection, the shells are ready to receive the adapters, a short description of the work on these may therefore be in order here. While the general practice in most shops of screwing the adapters into position is by means of a pair of holes drilled in the base, the method adopted in this plant is the use of a square of about 2 inches on the side and protruding about 7/8 of an inch from the body of the forging. The blanks are first centered on either end and then turned in the lathe, the pilot and flange machined to about 1/32 inch larger than the finished size, while the portion for the thread is turned to exact diameter of 6.67 inches, after which the shoulders are squared and undercut. The gauging of the thread diameter is accomplished by means of Johansson soap gauges, which are provided with insulated finger grips to insure increased accuracy. A view of this operation is shown in Fig. 10. Eight Advance-Rumley lathes perform the necessary operations. In addition to turning, the



FIG. 10. SIZING ADAPTERS PREPARATORY TO THREADING

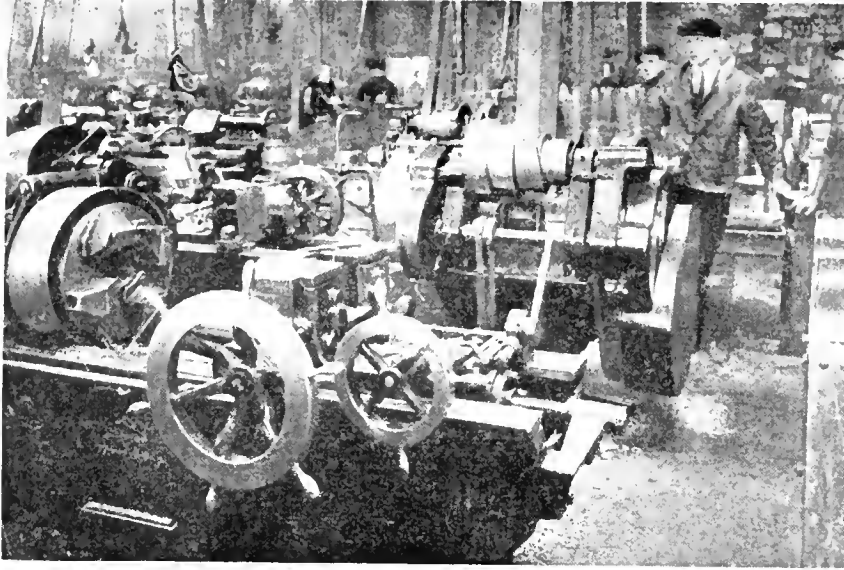

FIG. 11. "LANDIS" BOLT CUTTERS THREADING 9.2 IN. ADAPTERS.

ends are faced off at this setting. The threading is done in two Landis bolt cutting machines, these being shown in Fig. 11. Oil is used on the dies as better threads are produced. To insure the pilot and flange being concentric with the threaded portion, the adapters are gripped in a universal three jaw chuck; the jaws, which are soft, being threaded to suit the adapter.

The adapters are now ready to be fitted in, this operation being performed in the usual way of first serewing in for a trial fit and afterwards coating with Pettman cement and firmly serewing to a final position. It might be mentioned that these are threaded left hand to counteract the action of the shell should they develop a tendency to become loose, while the projectile is in flight. For the purpose of sawing off the projecting squares, three Napier band sawing machines are installed. Final facing is next performed in several Root & Van Dervoort special machines.

Copper Banding Operations

An essential feature in connection with the manufacture of shells is the necessity of securing sufficient and effective compression on the copper band when forcing same to position, and, to be certain that the copper is pressed well into the undercut and waves, the bands are thoroughly heated before being placed on the shells. The copper bands are first heated to a bright cherry red, for which purpose four Ferranti electric furnaces, especially designed have been installed. When heated to the desired temperature, the ring is placed in the press, the shell dropped over it, and a couple of applications of the pressure given, the shell being slightly turned between each

movement. The pressure of 2000 lbs. per square inch, used to operate the press, is derived from a three plunger pump; the pump and the press being supplied by the Metalwood Mfg. Co. Fig. 12 illustrates the above unit in operation. In addition to the increased ductility obtained by heating the band, the shrinkage when cooling aids in taking a firmer grip upon the shell.

Machining the copper band is similar to that on all other shells, being accomplished on five Jenekes improved band turning machines made by Warden King Co. Diagram XI on the Operation Chart shows the operations in detail: roughing with a broad nosed tool and finishing with a formed cutter, the large diameter being 9.34 inches, .005 inch variation either way being permitted.

A simple, yet highly serviceable method has been adopted for stamping the base of the shells; this interesting fixture being shown in the sketch Fig. 13. The casting A is machined on one side to a free fit on the diameter at the shell base, and holes broached in the desired location of a size suited to the stencils used. Narrow slots, C are cut in the side of the stamps, and the plates D

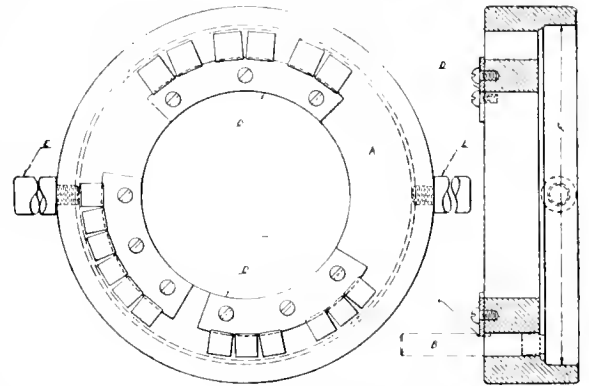

FIG. 13. STENCIL-HOLDING DEVICE.

secured in position, thus eliminating the possibility of the stencils being lost from the fixture. Handles E are provided for the convenient handling to and from the shells.

Machine work is now completed and the shells are given a final inspection preparatory to washing and varnishing. After washing in a soda solution to remove all trace of grease, the interior of the shells are rinsed by a spray of clear water, and, when dry, a bush is serewed into the nose to protect the thread from the varnish. This last process is accomplished in an efficient but rather cumbersome way. Five shells are placed on a specially constructed rack and secured in position, and then tilted beneath a trough having five outlet spouts with faucets to control the flow of the varnish as it passes into the shells. When the shells are filled, the supply is shut off and the rack again tilted to allow the liquid to empty into a receptacle below the fixture, from which the varnish is again pumped up to the higher level. The shells are again inspected, crated and otherwise prepared for shipping.



FIG. 12. HEATING AND PRESSING ON COPPER BANDS. "METALWOOD" PRESS.

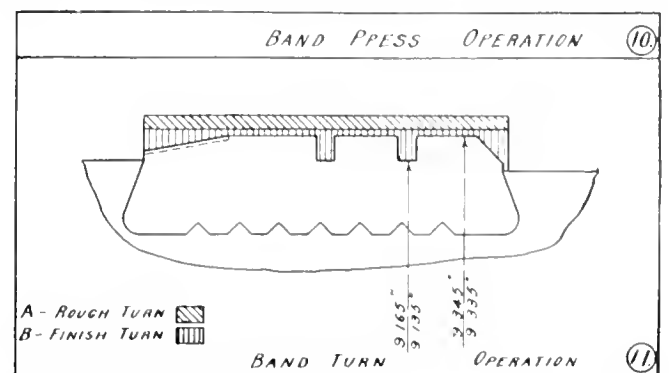
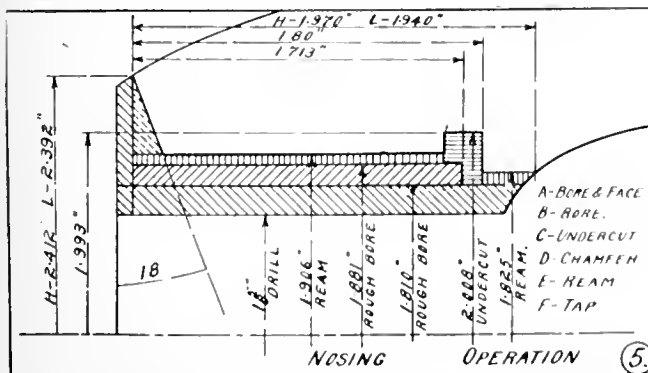
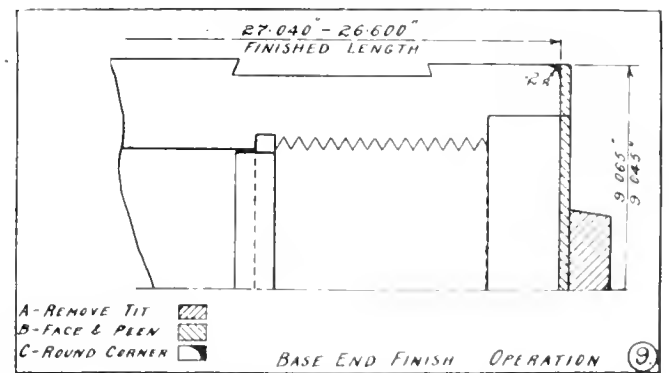
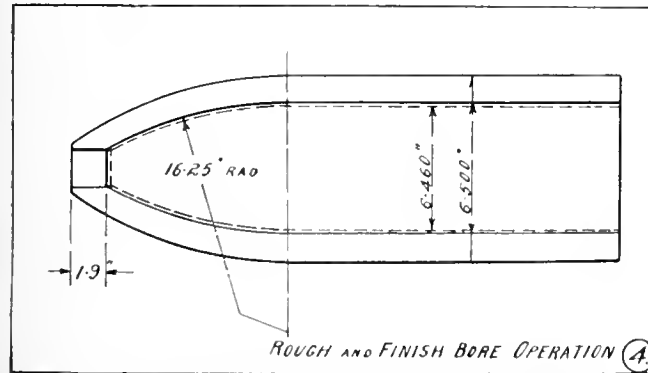
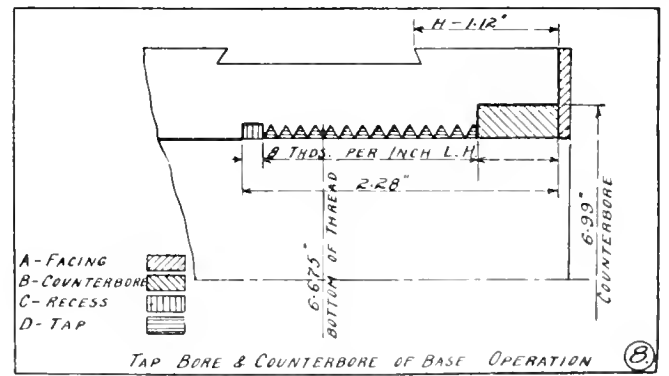
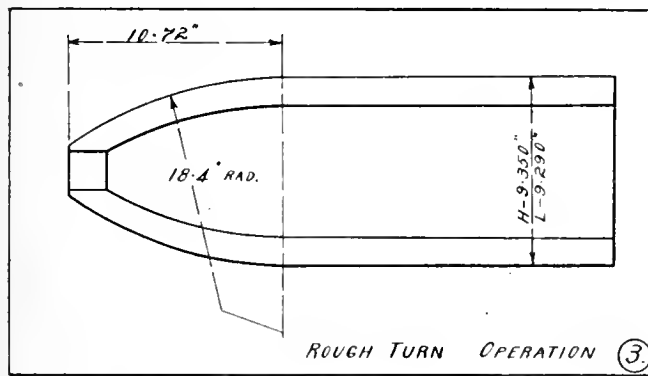
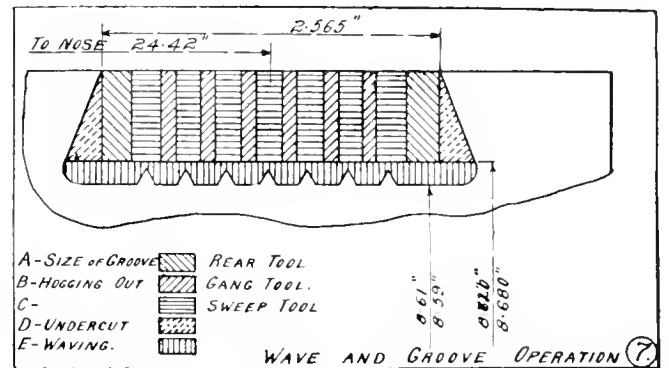
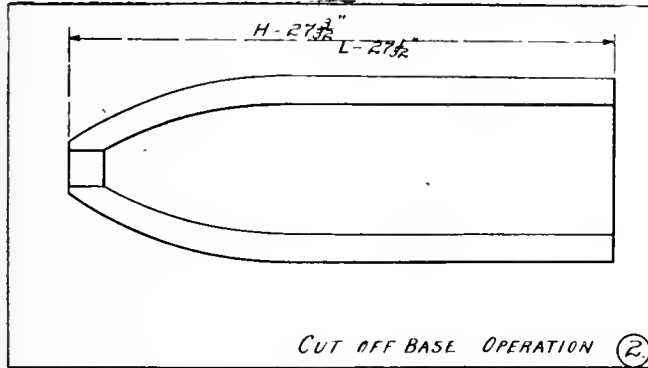
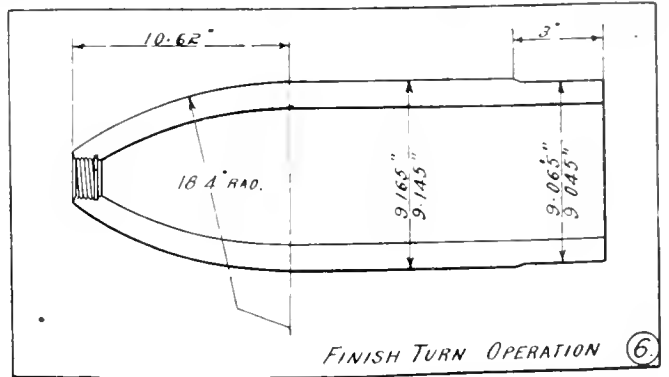
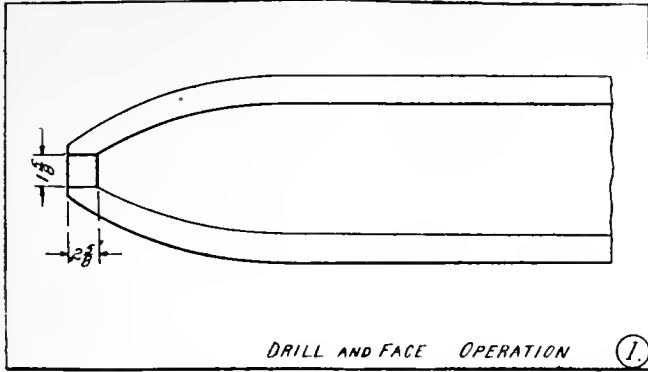

FIG. 14. MACHINING OPERATION SHEETS, .92 INS. HIGH EXPLOSIVE SHELL.

Shop Inspection Routine in 18 pdr. H.E. Shell Production

By A. F. Menzies

The ultimate value of each individual shell, irrespective of its type and size, is wholly dependent on the care taken to have it perfect in material structure, a masterpiece, as well, of mechanical engineering skill, while, at the same time conforming to a weight and measurement stipulation which individually or in combination is only tolerant within the very narrowest limits. The accompanying article features the routine adopted to achieve satisfactory output in a shop recently engaged on the machining of 18-pdr. high explosive shell.

PRINTERS' ink has been lavished on descriptions of the manufacture of shell; but a very important item of manufacture, shop inspection, has been little mentioned. Without adequate shop inspection, the results produced would be mainly scrap. It is not enough that shells be produced

these marks should be such that they will, if possible, remain on the shell until the work they guarantee has been proved correct by a subsequent operation. To illustrate, the mark denoting that the shell is correctly rough turned should remain visible until the outside is finished. On all finish operations,

sibility and the lame excuses invented on short notice are ludicrous.

For assistants the chief should select men who have a mind of their own, and who will not allow an operator to persuade them that it is good enough. Careful instruction should be given, also intelligent explanation of the various operations and their effect on succeeding ones. The assistants should be instructed to take nothing for granted and to believe only what the gauges tell them. The thing that couldn't happen is well worth watching for. Clearing up the work at the end of each shift should be insisted upon. This is not difficult where the operators are allowed a few minutes to clean their machines.

Variety in Shop Routine

The actual routine of shop inspection will vary, of course, with different shops, on account of different methods of manufacture. The following applied to a shop making 18 pdr. H.E. shells where the chief shop inspector was held responsible, in addition to the actual inspection, for routing the work, keeping track of the series and rectifications, cleaning the shells, and keeping the operators tallies.

The first inspection operation was at the saws where lengths were cut from the bars sufficient to make two shells. The length cut off and the squareness of the cut had to be examined, the former with a length gauge and the latter with the eye. The piece was stamped on each end with the heat number sym-

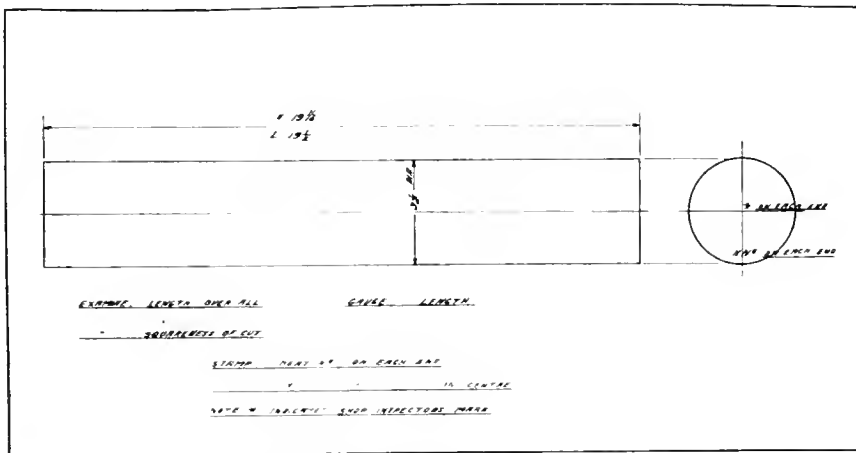

FIRST OPERATION—SAW-OFF LENGTH FOR TWO BILLETS, ALLOWING 3-16 IN. FOR PARTING.

which will meet the dimension limits; the weight must be correct, and to obtain this result without light weights and over weights, much closer dimension limits must be worked to than those allowed on the official drawing. For instance, an 18 pdr. H.E. shell that is shorter than the mean allowed length is almost certainly going to be a light one, unless it has very thick walls.

the mark should not be removed until after preliminary examination.

Such procedure enables a defect to be traced back to the parties responsible for it. This fact alone is worth a great deal as it enables a chief inspector to know which of his men is accepting incorrect work. There is nothing more

Inspection Between Operations

As a shop inspection which does not examine every shell after each operation is a farce, gauges, in addition to those used on the finished product, must be designed and used. The first matter to be attended to it to make up a drawing of the shell as it should be after each operation. Blueprints of these drawings can advantageously be hung up at the machines, and it is as well to have the special points to be inspected noted thereon. Instructions concerning work's marks on the shells denoting which operator did the work can also be effectively conveyed by this means.

Arrangement of work's marks should also be made. This marking may be done either by the operator or the inspector, if done by the former it should be the duty of the latter to see that the marks are correctly made. The location of

aggravating than to have a large number of rectifications sent out and to have no means of telling which shift accepted them. The average man dodges respon-

bol and work mark as shown in Fig. 1. After this the work was counted and passed on to the next machine.

The second operation on the piece was

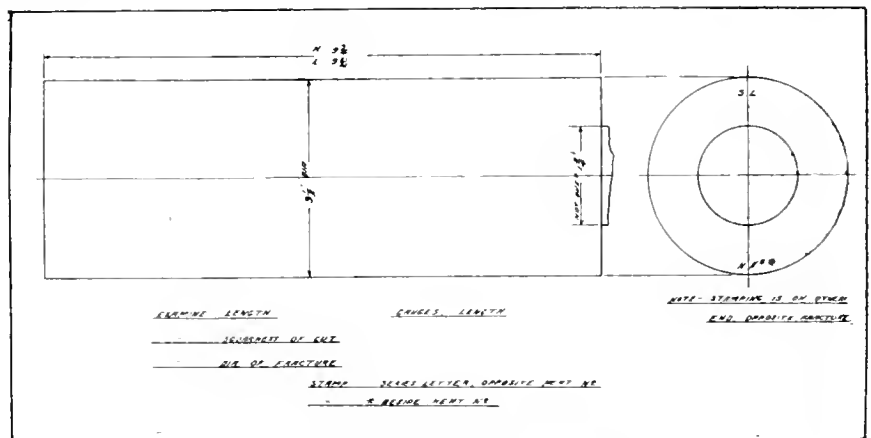

SECOND OPERATION—PART AND BREAK.

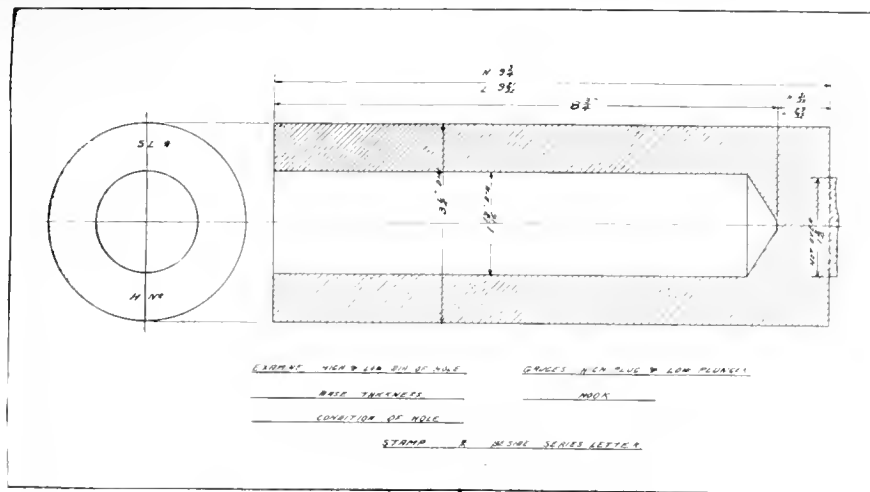

THIRD OPERATION—DRILLING OUT INTERIOR.

to part it into two billets. The parting was carried down to a diameter of from $1\frac{1}{2}$ ins. to $1\frac{3}{4}$ ins., and the two billets were then broken apart. The inspection required was to check the length and to see that the fracture was not too large in diameter to enter the stop in the drill press chucks. The work was marked as shown in second operation diagram, and, after being counted was stacked in piles, one deep, holding a series (250), for examination of fractures by the Government Examiner. The single pile allowed the examination of the fractured end, and also the placing of the acceptance stamp on the other end. As the marking up to this stage was on the end of the shell that was to be drilled, it had to be kept away from the centre to avoid being drilled out.

Drilling constituted the third operation. Here the size of the hole was examined with a low diameter plunger and a high diameter plug. The hole was looked into to see that it was in good shape and the base thickness was examined with a hook gauge. One arm of this gauge was pointed and touched the bottom of the hole in the centre, while the other arm lay along the side of the shell and had high and low limits marked on it which registered with the base. Checking the base thickness instead of the depth of the hole is the correct method of gauging the drilling, as the billets

vary in length and the stop comes on the base, therefore all base thicknesses should be the same. The marking was again on the open end as shown on third operation diagram.

heat number symbol and series letter transferred from the nose end to the base end. The work mark was as shown in fourth operation diagram. The shells were stacked nose up for Government Examiner to see his acceptance stamp on the open end. They were then reversed, and the acceptance stamp placed on the base. If the acceptance stamp was put on so that it would not be removed in the rough turning or base recess operations there was no need to transfer it again until the shells were put in for preliminary examination.

The fifth operation, centring, may not seem to be worthy of much inspection; but it most certainly is. The centres were tested for depth with a depth gauge in order to see that they had not been drilled so deep that they would not clean out in the base recess operation. About 10 per cent. of the shells were put back on the centring post and spun to see if they had been centred truly with the hole. Neglect of this is a fruitful source of eccentric shells.

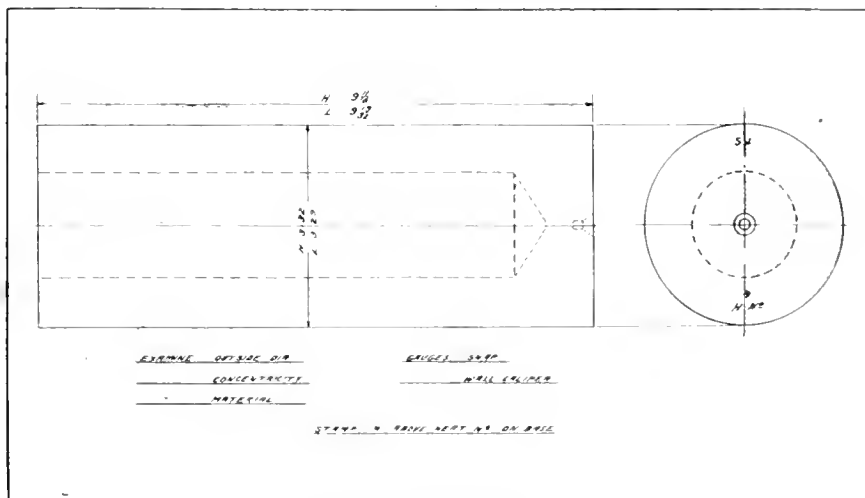

SIXTH OPERATION—ROUGH TURN BODY.

Facing Base and Centering

The fourth operation consisted of facing off the base. The base thickness was again gauged, this time more accurately, with a pillar gauge. The bases were also tested for flatness, and the

The marking for the centering operation is also shown on fourth and fifth operation diagram.

Rough and Finish Turning and Profiling

After the sixth operation, rough turning, the shells were gauged for diameter with a snap gauge. A careful examination of the material was also made for seams and other defects. When found correct the work was stamped and passed on to the rough nosing operation. This latter was rather important, in that here the shells were all brought to a uniform length. The length was checked with a length gauge and the profile with a gauge laid along the side of the shell. This gauge is not very reliable and the safest way is to put a shell ahead through the profile lathe to see if sufficient stock is being left on for finishing. As in the profile lathe, the work was stopped on the open end, it was necessary to see that the end-facing tool in the rough noser was cutting cleanly and not leaving ragged pieces sticking up which would alter the location of the profile. The work was here stamped on the open end.

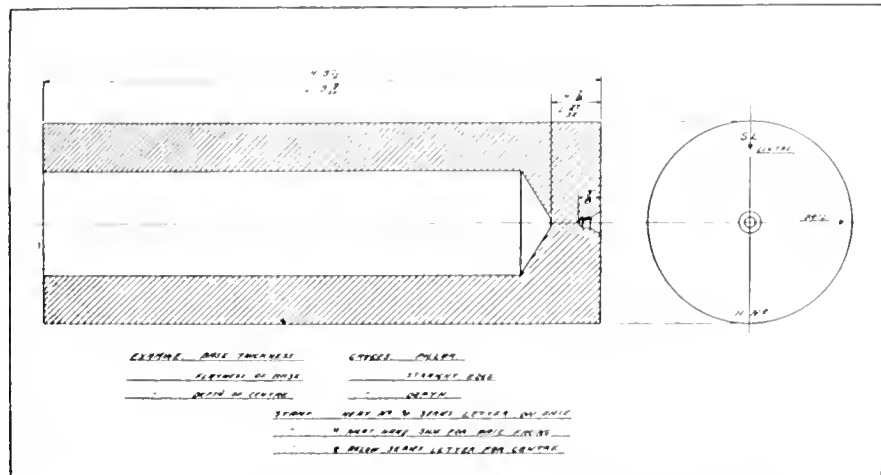

FOURTH AND FIFTH OPERATIONS FACE BASE AND CENTRE.

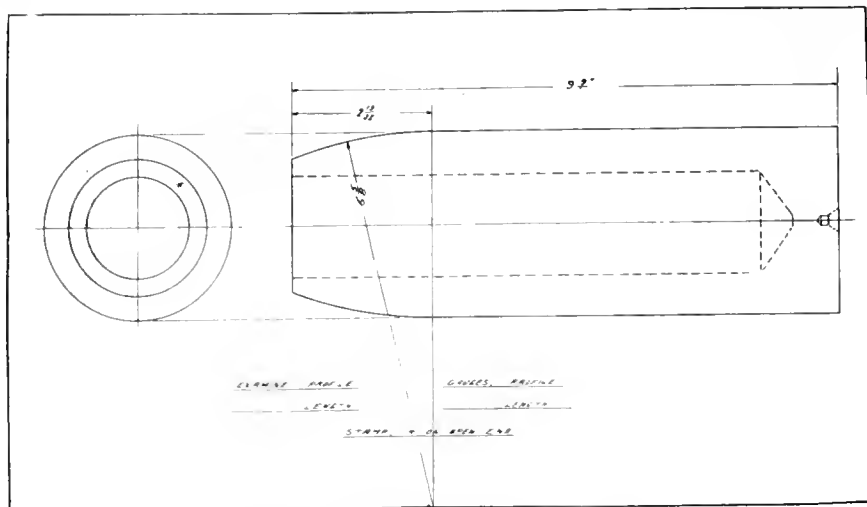

SEVENTH OPERATION—ROUGH NOSING.

The eighth operation, profiling, which also included finishing the outside of the shell, was next. The work was checked with the high diameter ring, the low diameter being gauged with a snap tried on at each end, and the middle. The profile was examined for shape and location, and the heat number and series letter transferred to the nose of the shell. It will be noted that the full heat number was here placed on the shell instead of the heat number symbol, which had been used previously. Using a symbol for the heat number saves a lot of stamping as a heat number may contain five or six figures whereas a symbol containing not more than two figures can just as easily be used. A careful exterior examination of the material was again made and all doubtful lines filed to see their extent. The work mark was placed under the series letter on the nose of the shell. It should be noted here that it is not safe to let the shells get below the mean diameter, as it is frequently found that they will turn out light weight.

Rough and Finish Boring

Rough boring the hole constituted the ninth operation, the work being gauged with a low diameter plunger and a high

diameter plug; the former being marked to check the depth of the rough bore. A percentage of the shells were tested for concentricity, and a watch kept on

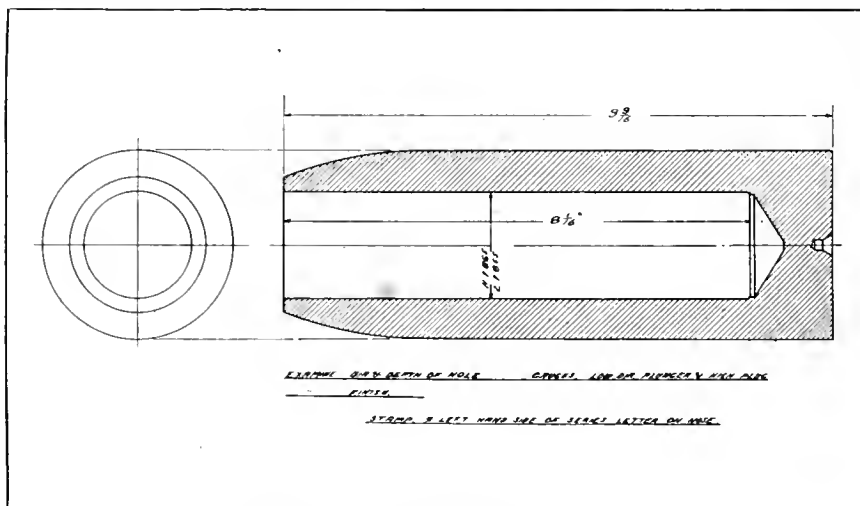

NINTH OPERATION—ROUGH BORING.

the chucks to see that they ran true. The bore was also examined to see that it was reasonably smooth. The work was marked on the left side of the series letter on the nose.

vice is therefore a better method of curing eccentric shells than all the fancy gauges for detecting them after they are made. The low end of the dumbbell gauge was used to see that the pocketing at the bottom of the hole was not excessive. The correctness of the inside finish operation was certified to by locating the stamp at the right hand side of the series letter on the nose.

Forming Nose Interior

The eleventh operation consisted of forming the nose of the shell. To test the concentricity of the part to be threaded with the cavity, a plunger was used. This plunger was marked, and gave an additional check on the depth of the hole; a high diameter plug was also tried in the nose. The angle of the fuse seat was checked with a small plate gauge made to the correct angle. Too much reliance should not be placed on this gauge, the best test to make is to send an occasional shell along to the thread miller and test the seat with the screw gauge. The high and low diameter of the recess on the outside was

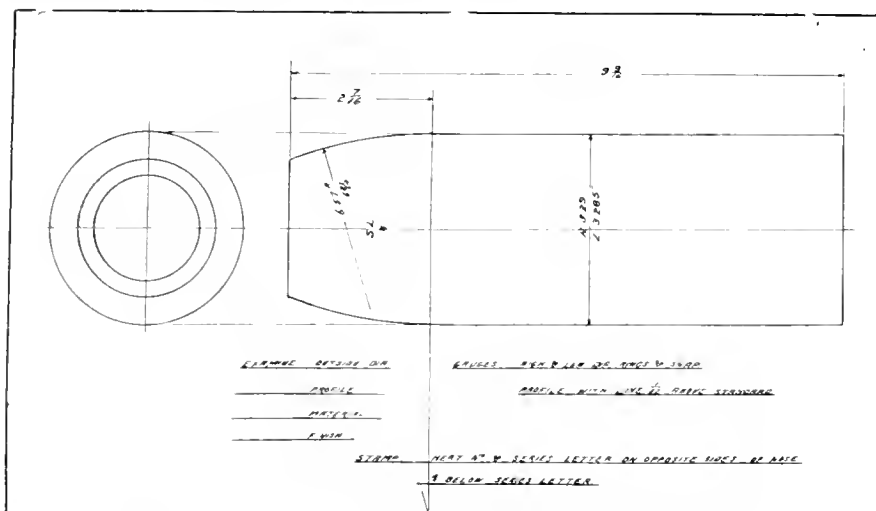

EIGHTH OPERATION—PROFILE AND OUTSIDE BODY FINISH.

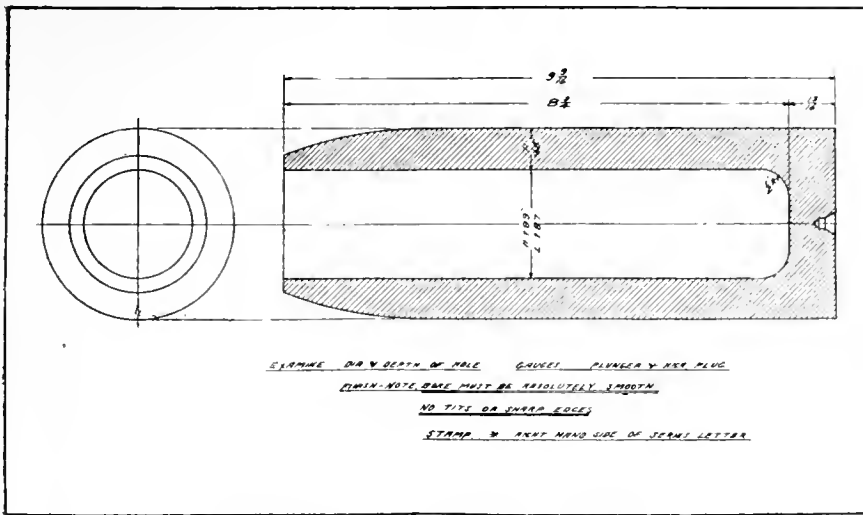

TENTH OPERATION—FINISH BORING.

gauged with a plate gauge drawn across the nose. The profile gauge was also tried on the shell to see that the line on it corresponded with the nose. The distance from the nose to the fuse hole undercut, both high and low, was checked and the undercut examined to see that it was large enough in diameter and free from sharp corners. Watching the diameter of the undercut is well worth while, if it is too small, it will surely cause trouble later on when the screw gauge is used. The distance to the undercut is very important. If it is too far down the shell it is a difficult rectification to make, and if it is even a very small amount too high up, the screw gauge will not seat; correcting this error may result in getting the undercut too wide. Just why this undercut could not be put, say 1-16 ins. further down, is not apparent; if it could, a lot of trouble and misery would be avoided. The mark for the correctness of the nose was made above the series letter on the nose.

the side of the shell, having a mark on it which corresponded with the upper edge of the recess. The diameter, high and low of the recess, was tested with

would deceive one if the eye were depended on alone. The recess was examined to see that it was cleanly cut, the ribs not torn, and that the rags were removed from its edges. A plate gauge was used for the width of the recess. The correctness of this operation was certified to by a work mark located in the recess between the ribs and in line with the series letter. There are two reasons for locating the shop inspection marks around the series letter. One is that the heat number is already appropriated by the higher ups, while the other is that it forces the inspector to look at the series letter, and a stray shell will be detected.

The thirteenth operation, forming the base recess, is one that will repay watching if rectifications are to be kept down. The thickness left in the base of the shell was examined by putting the shell on a pillar gauge, no limits were allowed as it was endeavoured to hold a constant thickness. The flatness and smoothness of the recess were examined with a straight edge. A 2 ins. scale

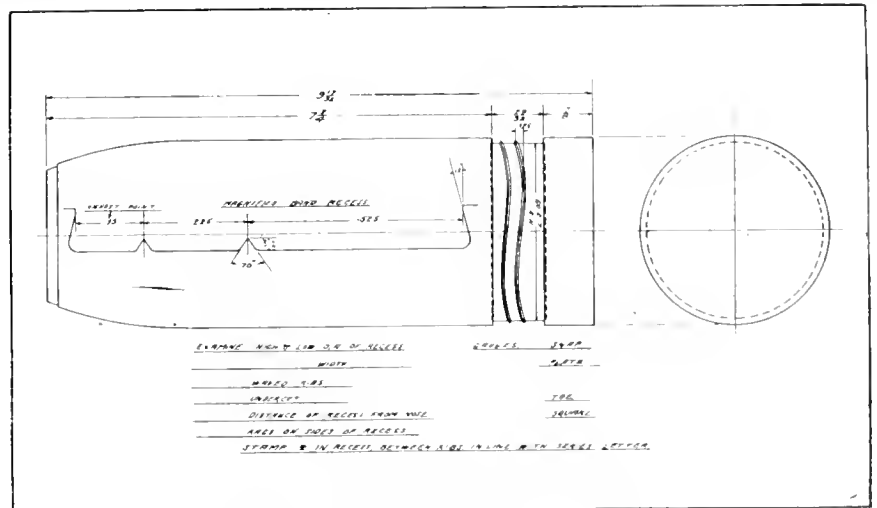

TWELFTH OPERATION—BAND RECESS.

Band and Base Recessing

Putting in the band recess came next in order. The location of the recess was checked with a gauge made like a try square. The short leg lay across the nose while the long leg extended down

a snap gauge. The size of the ribs and the undercut can be examined with the eye; but it is advisable to use the gauges on these parts frequently in order to catch a gradual change which

may be used for this work; but it is difficult to handle as the fingers obstruct the light. A better appliance is a straight edge deep enough to hold easily. The diameter of the part to be threaded and also the counterbore were examined with plug gauges. The height from the bottom of the recess to the top of the thread was also checked. If, on account of wear on the tools, this distance was allowed to get too high, threads would begin to show up when the base of the shell was faced off to weight. Following the example of the Government Examiners, the work was marked in the base near the side.

Nose and Base Threading

After the fuse hole was threaded, the screw gauge was used to see that it was sized correctly and that the thread was true with the seat. The high diameter plug was also tried in the thread. This plug is a big improvement over the high screw gauge formerly used in that it allows more latitude for setting the tap and yet it catches nearly all the defe-

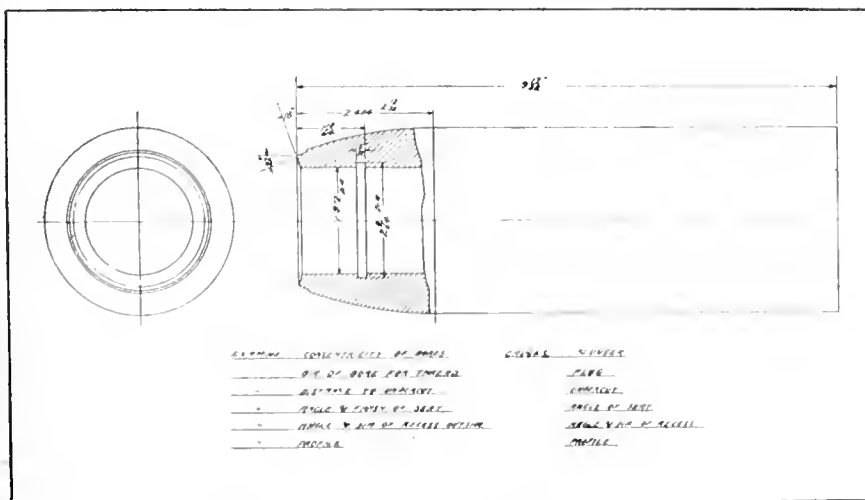

ELEVENTH OPERATION—FORMING NOSE INTERIOR.

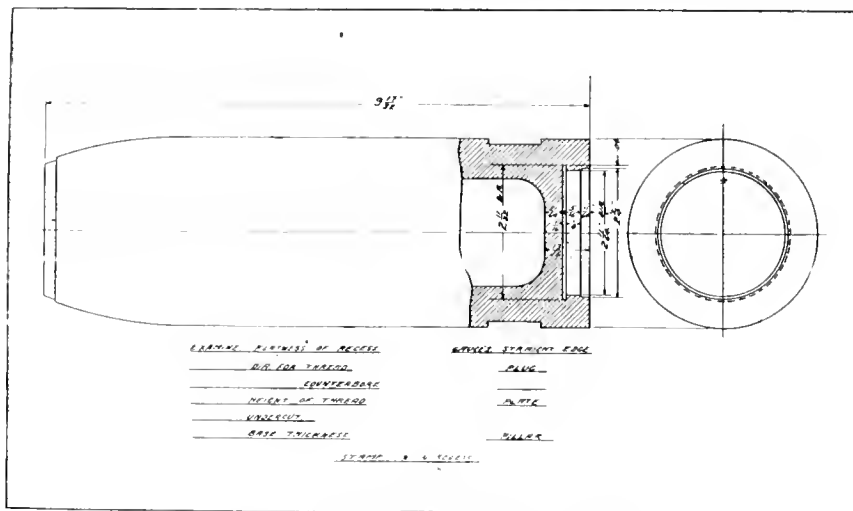

THIRTEENTH OPERATION—BASE RECESS.

tive threads. The thread was examined to see that it was all there, and that the shoulder below the undercut had not been damaged by the hand sizing tap. The correctness of the fuse hole was certified to by a work mark placed on the side of the shell in line with the series letter.

Base tapping was an operation which was not gauged, as solid taps were used. The threads were examined, and care taken to see that the bottom of the base recess had not been damaged by chips getting under the end of the tap.

The shells were next thoroughly cleaned, and, before being passed into the inspection room, were subjected to a final shop inspection. It was not found neces-

sary to go over the shells here with all the gauges, the more important points, however, were carefully covered, and of course any item which was known to have been slipped up on the line was

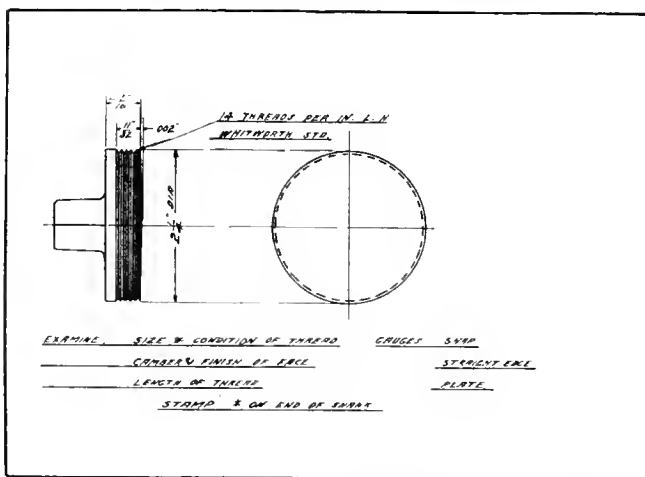

FIFTEENTH OPERATION—MACHINING BASE PLATES

specially looked out for at this stage.

Base Plate Finishing

Machining the base plates is also a preliminary operation and should be

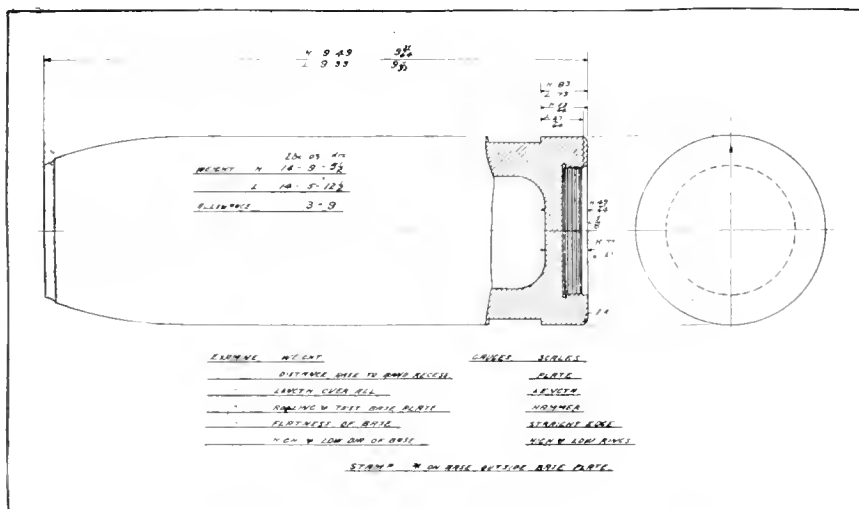

FOURTEENTH OPERATION—FACE-OFF BASE TO WEIGHT.

mentioned. The base plates were examined with a snap gauge for diameter over the threads. The length of the thread was gauged with a small plate gauge, while the camber on the face was examined with a gauge having a step of .004 ins. on one side of it. When laid on the face, this gauge should touch across one half of the diameter, and the step should touch at the circumference directly opposite, thus giving the required camber of .002 ins. The threads were tested by trying a few base plates in sizing die, which was kept adjusted to suit the solid tap used on the base recess. The finish on the face and the material were also examined. The base plates were marked on the end of the square shank.



AN AMERICAN CONFESSION

IN the early days of the great war says the *Scientific American*, "the American public was dazzled and astounded by the public reports of the contracts for enormous quantities of munitions, at unheard-of prices that were being placed with our manufacturers by the European Allies, and it was regarded as quite natural and fitting that European countries, in their condition of unpreparedness, and dire necessity, should turn to America, with its reputation for mechanical ingenuity and ability, and its great factories, for assistance. American manufacturing organization and ability was to be pitted against that of Germany, and the result was contemplated with complacency. American energy and efficiency was to show its superiority over the supposedly stereotyped routine of continental shops; but the actual results have been a humiliating surprise, in many instances, both to the public and to many an optimistic contractor... One of the worst features of our failure to make good in the production of arms and ammunition of a satisfactory quality is the loss of prestige that American manufacturers will suffer after the war is over, when trade will be needed to keep all of our new mushroom plants going.... The trouble with our manufacturers does not lie in the character of our machinery, nor in the ability of American workmen, for we have as skilful mechanics as any other country, but rather in matters of organization and superintendence. Then, again, there is a fatal tendency among many of our shops, when taking up a new product, to start in without a thorough understanding of the requirements, and to jump at conclusions. Another habit is to attempt to tell the buyer what he ought to have instead of giving him what he wants."



Vancouver, B.C.—The establishment of a smelter on the coast of British Columbia with a measure of Government assistance was foreshadowed in a speech read by Lieut.-Governor Barnard on the occasion of the opening of the Provincial Legislature on March 1.

Female Labor on 8 ins. High Explosive Shell Machining

Staff Article

Although not engaged in the production of the largest and heaviest shell being furnished by Canadian metal-working establishments, the plant from which the accompanying article was derived is engaged in the machining of that next in order in the matters of type, size and weight. An added interest may, however, be aroused when cognizance is taken of the excellence of the facilities provided for reducing to a minimum the labor of handling such heavy pieces as 8-inch high explosive shell bodies and adapters by women operators.

IT IS more than probable that when events enable an impartial review to be made of the history of munitions making in Canada, the entry of female help, as an active factor in production,

entire work of machining, assembling, and inspecting 8 in. shells and adapters is accomplished by female help with one or two exceptions, which will be noted in due course.

The subdivision of the work resulted in about twenty-five separate handlings. While large, however, the time and labor involved is probably less, all told, than would be the case in a shop employing skilled mechanics and using standard types of machines which do a maximum number of operations at one setting. This result was accomplished by installing conveyor tracks of a suitable type and on such a liberal scale that no machine operator is required to exert more than a ten or twelve pound effort in any direction either while chucking the work or operating the machine. Lifting of the shells by unaided physical effort is entirely tabooed.

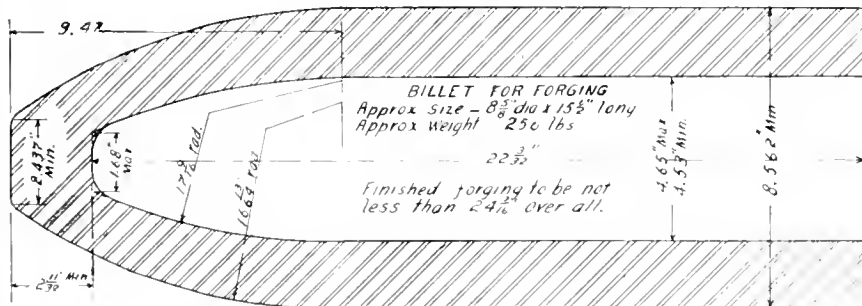

APPROXIMATE FORGING SIZES OF 8-INCH HOWITZER SHELL.

will be given a prominent place, not only on account of the novelty of the situation, but because of the stimulating effect it has had in developing machine shop methods, devices, and conditions. Women and girls accustomed to office, warehouse, and light factory work are now employed successfully on all sizes of shells, although the largest and smallest offer the best proposition, the former because installations of labor-saving devices which were desirable, even with men operators—were with suitable refinements, readily adaptable to operation by women, while 12 and 18 pdr. shells could be handled readily without special apparatus.

Women Workers

The executives of the plant described in this article were amongst the first to reach a decision on the matter, and the

It was assumed at the outset that mechanical ability should not be expected from the great majority of the help, and for this reason the operations were so simplified that any worker of average intelligence could quickly understand the work, while, on the other hand, the machines were designed and built on a system which not only gave them a high degree of " fool-proofness," but insured a surprisingly high output of accurate work.

Type of Equipment

A satisfactory system of handling having been decided upon, the problem of machines remained, and the manner in which this has been tackled and solved constitutes, in the opinion of many, a

LIST OF OPERATIONS.

- | | |
|-----------------------------|-------------------------|
| Body. | Finish ream. |
| Rough drill nose. | Rough tap base. |
| Rough turn body. | Finish tap base. |
| Rough turn profile. | |
| Cut off base and nose. | General. |
| Rough bore body. | Finish and tap nose. |
| Rough bore profile. | Fit and drive adapter. |
| Finish ream interior. | Roll adapter joint. |
| Second rough turn body. | Rough face and weigh. |
| Finish turn body. | Groove and weigh. |
| Second rough turn profile. | Press on copper band. |
| Finish turn profile. | Finish turn copper band |
| Base. | Cut off square. |
| Rough counterbore and face. | Finish face, etc. |
| Finish ream counterbox. | Government inspection. |
| | Varnish, paint and ship |

unique instance of mechanical genius, daring and accomplishment. Tradition has been rudely jarred in many other fields in the last three years, but in none more than the machine shop.

Quantity production in gasoline engine manufacture had previously laid good groundwork on which present developments were built, but even the most sanguine of engine builders never dreamed of doing work of similar weight and accuracy at anything like the speed obtaining in this plant.

Out of the twenty-odd operations referred to, about sixteen are done on machines which, except for the gearing between belt and spindle are operated entirely by hydraulic power. Many of these are standard heavy duty 26-in. lathes, stripped of feed gears, shafts, etc., and fitted with hydraulic cylinders which operate the carriage travel, tail stock, spindle, chuck, or driver for work, and in the case of driving the adapters, torsion is directly applied through a hydraulically operated ratchet lever.

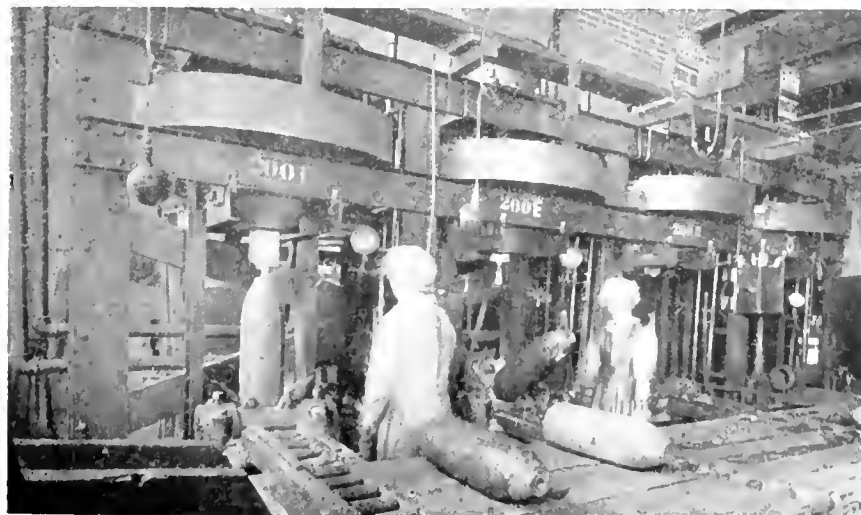

DRILLING SHELL NOSES IN A FOUR-SPINDLE MACHINE WITH INDIVIDUAL MOTOR DRIVES AND HYDRAULIC FEEDS AND HANDLING GEAR

The foregoing table of operations gives an approximate idea of the system, and in conjunction with the photographs and line drawings will, it is hoped, convey to the reader, a clear idea of the principal features of the system.

Hydraulic Control

The method of operating the hydraulic cylinders might be termed constant pressure with controlled exhaust; that is to say, the total pressure on either side of a piston is constant and by letting the fluid on the other side escape more or less rapidly, the speed of the piston, and consequently the rate of feed of the cutting tool is increased or decreased. In order to get consistent results with this system it is necessary to have sufficient pressure on the piston to insure its movement being entirely dependent on the escape of the exhaust. Thus, if a heavy side were alternating with a light side, the tool must be fed under the heavy cut with the same speed as on the light, so that the maximum cut which the machine will take is a factor in deciding the amount of power required in any one cylinder.

A careful investigation of these points resulted in a pressure of from 55 to 70 lbs. per sq. in. being adopted as most suitable, taking into account the available spaces in which cylinders had to



FIG. 1. GAUGE FOR TESTING CONCENTRICITY OF DRILLED NOSE WITH ROUGH BORE.

be placed with a consequent limit to their diameter. While no definite data are available as yet, the fact that patent rights have been applied for, indicates that results have fully met anticipations and the commercial development of the system is a probability of the future.

Reviewing the work in a progressive manner, reference may be made to the

receiving of the forgings which are discharged directly from the railroad car onto an elevating conveyor which passes the forgings through a small, coal fired furnace for taking the chill off the ma-

pulleys to individual motors on the floor, back of the machine. As will be observed from the illustration, the four machines are built as a unit, the framework being of heavy channel sections

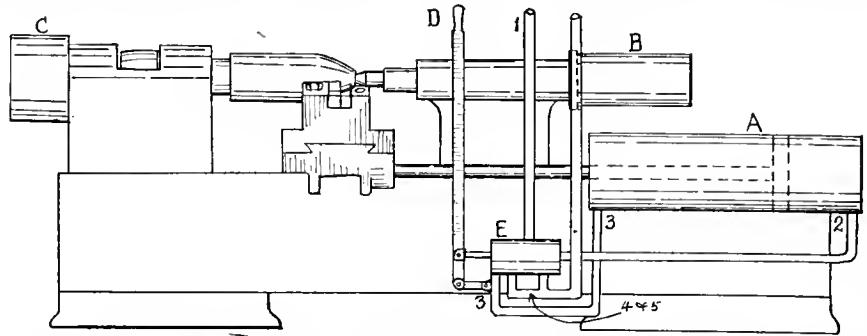

FIG. 2. DIAGRAM OF LATHE, SHOWING PRINCIPLES OF HYDRAULIC FEED CONTROL.

terial during cold weather, avoiding loss of time or undue discomfort in handling them a few minutes later in the shop.

A Unique Drilling Machine

The forgings enter the building at a steady rate of one every so many seconds, according to requirements, the entrance being through an opening in the wall behind the four-spindle nose-drilling machine, illustrated on page 207. The opening is level with the platform shown in the foreground, and the forging travels with very little effort on the roller runway till it is abreast of the platform when it is rolled along by men helpers to the particular spindle in which it is to be drilled. This drilling machine is an outstanding example of the originality of equipment throughout the shop and by means of two valves the operator controls the work from the instant when it is pushed along the track onto the supporting arbor, the tilting of the arbor from a horizontal to a vertical position being done by hydraulic power also. The spindle of the machine is a square sliding shaft driven by a large pulley with belt drive over guide

with two platforms on the upper part, one carrying the driving pulleys and the other carrying the hydraulic feed cylinders.

The tilting arbor is controlled by a four-way valve which is referred to

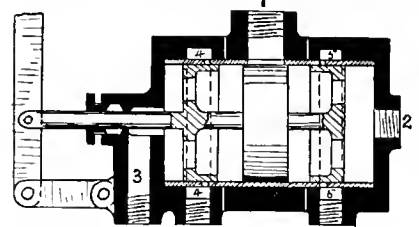

FIG. 2. SECTION OF HYDRAULIC CONTROL VALVE.

subsequently. No preliminary centering is done, as the drill used is merely long enough to provide for a reasonable amount of grinding and is socketed directly into the end of the square spindle, giving ample rigidity when starting the hole on uneven surfaces.

The drilled forging is tested with a gauge, as shown in line drawing, Fig. 1, which checks the concentricity of the hole with the internal surfaces, after which the forging is sent along one of several runways which extend along the shop, and has only a few feet to travel when it reaches the rough turning lathes.

The machines for each successive operation are arranged transversely across the length of the shop so that several streams of shells are proceeding parallel with each other through the various zones of operation until the primary lathe work is accomplished and the shell is ready for the group operations connected with the base, nose, and band.

A Lathe Without Feed Gears

On this page is reproduced a view of a hydraulic lathe on the rough turning operation. This is a standard 26-in. heavy duty lathe which was formerly built in considerable quantities by this firm for other concerns as well as for its own use. Those in use here are all hydraulically operated, the line drawings, Figs. 2 and 3, showing diagrammatically the method of operation. All feed gears and shafts, carriage apron, and tailstock hand-wheel have been re-

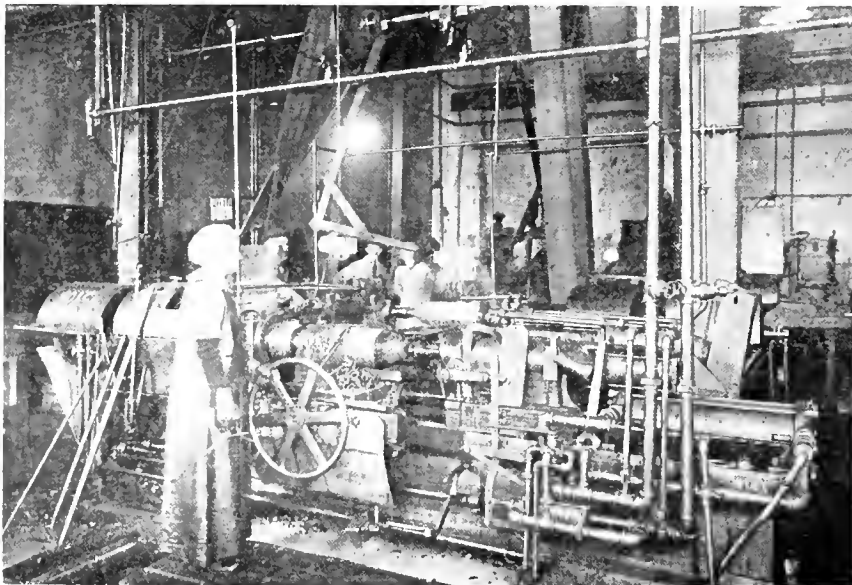

ROUGHING 8-IN. SHELLS ON LATHE EQUIPPED WITH HYDRAULIC FEED TO SADDLE, HYDRAULIC CHUCK AND TAILSTOCK SPINDLE.

moved. At the end of the bed cylinder A rests between the shears and is connected to the carriage by a piston rod which extends through below the tailstock casting. On the rear end of the tailstock casting a small cylinder, B, is

cape through passages 3 and 4. By suitable arrangement of holes in valve E the exhaust can be regulated to a nicety resulting in an ideally smooth uniform and powerful movement of the lathe carriage in either direction and at any speed, variable while the tool is cutting.

Handling the Forging

The handling devices are very simple and obvious, though not in general use. Each conveyor track is laid between two rows of machines which are loaded from the back. Reference to the illustration will show a supporting frame between the shell and the carriage. This is a hinged portion on the end of a branch from the main track. When placing a shell in the lathe, the operator has it rolled toward her by a helper who serves a group of machines. Arrived on the frame, she presses a pedal with right foot just below carriage, thus raising the shell level with the spindle. The shell rests on rollers carried by the frame and little effort is necessary to slip it over the driver. Still holding the pedal down, she opens the tailstock valve which causes the tail centre to advance against the hole in the nose with a certain definite pressure, after which the tailstock spindle is locked in position and machining commenced.

Use of Stellite

The cutting metal used in this and all the other turning operations is Stellite. The various grades of this metal now obtainable enable a wide variety of requirements to be met. As used in the majority of the machines in this plant, stellite is in the form of 1 in. square bars supported in solid tool boxes with no overhang, and clamped along their full length to within a very short distance of the point. For reasons of comfort and safety, a copious supply of lubricant is used, although a cutting speed of 55 ft. per min with 1/4 in. feed and 1/2 in. in depth of cut, results in chips which are uncomfortably hot in spite of the lubricant. The length of the parallel portion rough turned at this time is

approximately 14 in., and on occasion a stellite tool has rough turned 60 forgings without grinding, average performances being well over 50 forgings. When it is considered that the former figure is equivalent to 840 feet of 8 in. shafting, while the tool passes over a surface exceeding 1 1/4 miles in length, the wonderful nature of this alloy is more readily comprehended.

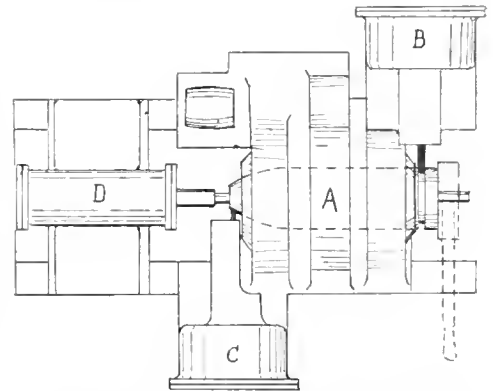

FIG. 4 PLAN OF CUTTING-OFF MACHINE SHOWING FEED AND EJECTOR CYLINDERS.

The nose profile is now rough turned in a 26-in. lathe of the type used for the body diameter, thus completing those operations in which the heaviest work is done.

Double End Cutting-off

The operation of cutting-off the base and nose is performed simultaneously in a specially constructed machine. In the course of certain experiments the engineering department evolved a driving head in which the shell is held inside of the driving spindle so that both ends can be operated on simultaneously. The experiments were not completed but several of the machine parts were found adaptable in a number of instances such as this, so that the entire equipment possesses a degree of individuality found in few, if any, other shops engaged in munitions.

Line drawing Fig. 4 is a plan view of this machine, A being the driving head.

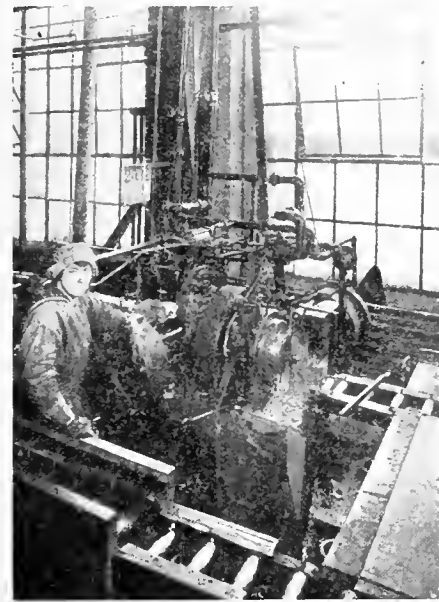

DOUBLE-END CUTTING-OFF MACHINE WITH HYDRAULIC FEEDS AND EJECTOR.

mounted for actuating the tailstock spindle, while on the rear end of the headstock a large diameter cylinder, C, is mounted, which actuates the draw bar through the spindle to tighten the self-centering expanding driver which grips the forging on the inside. Lever D operates the control valve E connected with cylinder A, and by moving this lever more or less in the desired direction, the piston in the cylinder and also the lathe carriage is moved accordingly.

Simplified Control

As seen in the engraving the control for the three cylinders has been well centralized. A four-way valve on top of the tailstock controls cylinder B. Another four-way valve just above the shears, in front of lever D controls the driver, lever D itself being placed within easy reach, but not so as to interfere with the operator's movements. Contrary to expectation, the piping is comparatively simple in arrangement, although the improvised nature of the various devices imparts a somewhat complex appearance to the apparatus.

The controlling valve E, Fig. 3, is numbered to correspond with Fig. 2; it is shown in midposition. Pressure inlet 1 is closed, as are also the exhaust ports into outlet passages 4 and 5. Connections 2 and 3 go one to each end of cylinder A. When lever D is moved to the left, the solid central piston allows pressure to pass to the right through the perforated piston into passage 2 and thence to the right end of cylinder A. No movement can take place, however, until the other perforated piston uncovers exhaust ports into space 4, allowing liquid from the left end of cylinder A to es-

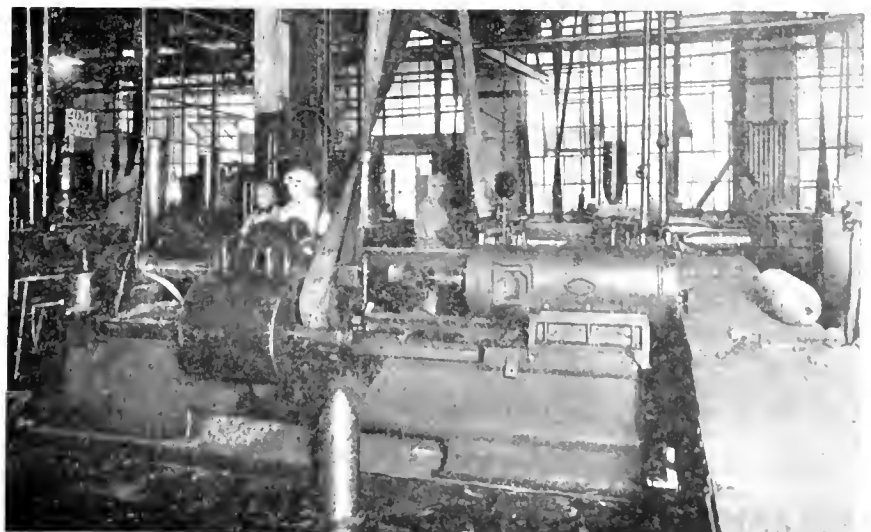

VIEW OF BORING MACHINE SHOWING HYDRAULIC FEED CYLINDER, DRIVING HEAD AND CLAMPING FIXTURE.

B the base cylinder, C the nose cylinder and D the chucking cylinder. These four units are securely bolted to a couple of 18 in. x 6 in. I beams and com-

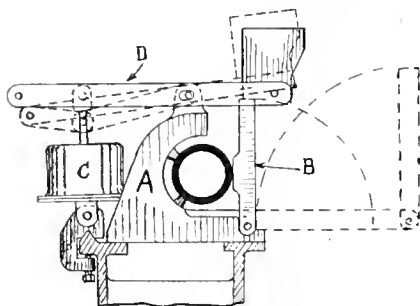

FIG. 5. HYDRAULIC CLAMPING FIXTURE FOR SHELLS.

plete the operation on both ends in 4 min. 8 sec. The exterior of the shell nose being rough turned, the interior of chuck is curved to fit it. The piston rod of chucking cylinder D extends through the shell during the operation and by means of a detachable cross bar, is employed to draw the shell tightly into the curved end and hold it there while chuck jaws are tightened on the base end. On completion of the cut, the chucking cylinder D forces the shell out onto a short runway (see illustration on page 209 from where it is rolled back

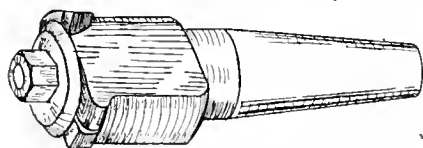

FIG. 6. THREE CUTTER BORING HEAD FOR ROUGH BORING FORGINGS.

into the main conveyor to proceed to the boring machines.

The disposition of the metal in the forging, diametrically, has therefore been determined from the bore, starting with the drilling operation where the forging was centered on an arbor so that the hole in the nose was concentric with the bore of the forging, subsequent rough turning removing any eccentricity in the walls, while the shell as now delivered to the boring machines has a machined diameter for chucking by, and a machined surface at the nose end which is now the starting point for locating lengthwise dimensions.

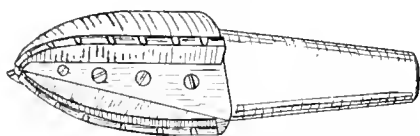

FIG. 7. ACORN TYPE OF HEAD FOR MACHINING INTERIOR PROFILE OF NOSE.

Boring Operations

The work of machining the interior is divided into three groups of operations, boring, base finishing and nose finishing. The boring operations are three in number, rough bore straight, rough bore nose and finish ream; identical machines are

used in each operation, with suitable cutter heads for each.

One of these machines is illustrated on page 209. The main casting will be recognized as a lathe bed, the driving head is the same unit as used on the cutting-off machine, the hydraulic feed cylinder at the right was cast from the pattern of a gas engine cylinder, while the shell is chucked by a hydraulic clamp in the fixture at the other end of the bed. The illustration also shows one of the transverse platforms connecting the main runways, one of which passes behind the machine illustrated. From this runway a short hinged gangway enables the shells to be rolled straight into the fixture, which consists of a horizontal open-sided gap casting A; see line drawing, Fig. 5. The shell is centered on three point contact, two of which are inserted hardened steel blocks supporting the shell at either end of the straight machined portion, while clamp bar B is tightened against the opposite side. Meanwhile the machined end of the nose has been placed in contact with the end of casting A, which locates it positively in relation to the feed bar stops, and also allows the use of a copious stream of lubricant applied at the proper place. A simple arrangement of toggle gear is combined with hydraulic cylinder C. When the fixture is open, the piston is drawn down, contracting the toggle and raising the opposite end of links D, while bar B occupies a horizontal position as shown by dotted lines. When clamped tight, the parts occupy the positions shown by the full lines. The only effort required of the operator being that necessary to swing clamp B up into position.

The driving head which occupies the centre of the machine is provided with a long square hole through the centre in which the square boring spindle is a very accurate fit. This square hole is of sufficient length to maintain the spindle in accurate alignment with the centre of the shell as held in the chuck, and continuous operation 24 hours per day and 7 days per week, has failed to reveal any weakness in several months' operation. The piston rod is coupled to the square spindle through the medium of a thrust bearing and in the case of rough boring, it feeds the tool at $\frac{1}{4}$ in. per revolution. It is able to do so because of the three cutter tool used, which reduces the work of each cutter and produces a reasonably smooth surface which can be afterwards reamed at one pass. Line drawing, Fig. 6, indicates the type of cutter referred to. The portion bored is approximately 14 in. long and occupies 2 min. 5 sec. of actual cutting time.

Nose Boring Tools

The tools used in boring and finishing the nose interior are of similar design with three inserted teeth. The rougher is notched as shown in line drawing Fig. 7, while the finisher is carefully sized all over so as to finish both the parallel portion and the nose. Considerable care is exercised in the

latter operation to insure a smooth finish, thus extending the time to 4 min. 10 sec.

In all of these boring machines, posi-

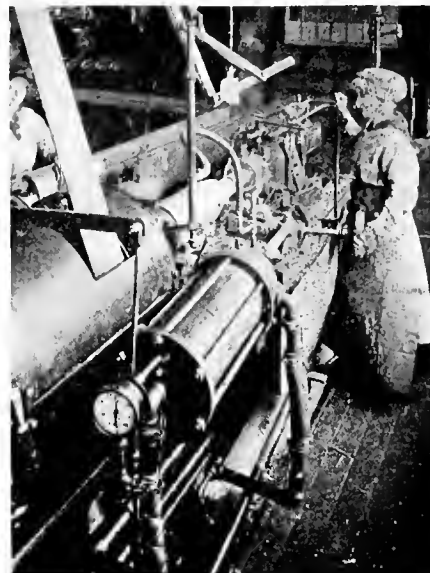

FINISHING PROFILE OF SHELL NOSE. THE CYLINDER IN THE FOREGROUND OPERATES THE RADIAL TOOL-BOX.

tive stops are provided on the end of the square spindle next feed cylinder. These make contact with the end of the square hole driving sleeve, dispensing with any gauging on the part of the operator.

Maintaining Accuracy

In spite of the close limits which are held in these roughing operations, the rough drilled hole in the nose may now be slightly eccentric with the finished bore, and this inaccuracy is removed by holding the shell on a formed

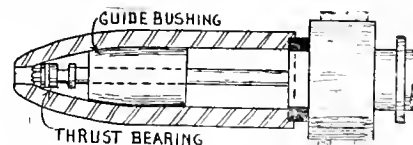

FIG. 8. ARRANGEMENT OF ROUGHING CUTTER BAR FOR RECESSING BASE.

arbor mounted in the special geared head previously referred to, while a turret with suitable tools trues up the hole and forms a beveled edge by which the shell may be supported on the tailstock centre during the final machining of the exterior, thus insuring the requisite degree of concentricity between interior and exterior.

These operations consist of two finishing cuts on the body and the same on

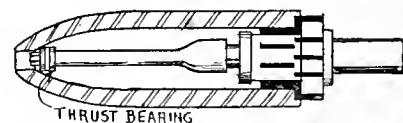

FIG. 9. TWO DIAMETER REAMER FINISHING BASE. THRUST BEARING ACTS AS FEED STOP.

the profile. The first finishing cut brings the body diameter to nearly size, and also reduces the base diameter up to where the hand groove is cut; the sec-

ond cut is the final and brings the body diameter within the required limits. Similar procedure on the nose profile completes what might be termed operations of the first magnitude, which impart the basic accuracy to the product.

Profiling Lathes

Profile-turning on the nose is the concluding operation of the primary group. Both in the roughing and finishing operations the thickness of metal is determined positively by the use of a sleeve, one end of which fits against the finished interior surface of the nose, while the other is positioned against the end of the driver in the lathe spindle. The only movement of the tool, therefore, is radial, passing around the curve of the nose, and this allows the use of a fixed carriage, leaving the depth of cut as the only adjustment over which the operator has control. See page 210.

Radial movement is imparted to the tool block by the cylinder shown in foreground, which is pivotally mounted on the carriage, so that when the piston is full back, the radial link is at right angles to the shell.

All that the operator has to do in the way of tooling is to feed forward till the tool is touching the shell, and then push over the control lever located at her right, the distance through which the lever is moved governing the rate of feed. Because of the pivoting of the cylinder, flexible pipe connections are necessary. Hydraulically operated drivers and tailstock spindles are fitted on all of these lathes.

This operation is an instance of the wide range of application of Stellite. With a feed of $\frac{1}{8}$ in. per rev. and a light finishing cut, the finished surface is all that can be desired. The cutting speed starts at over 200 ft. per min. on the

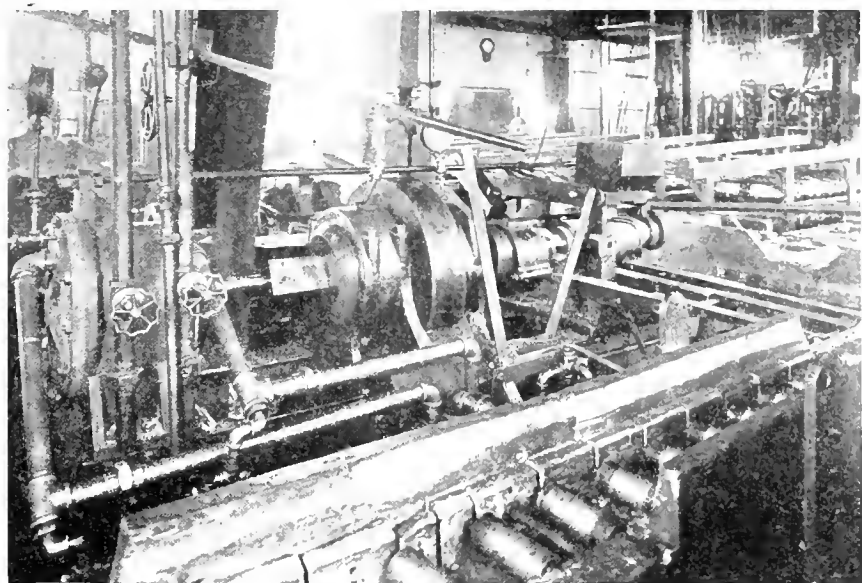

ADAPTER DRIVING MACHINE WITH HYDRAULIC RATCHET FOR FINAL TIGHTENING OF ADAPTERS IN PLACE.

body and gradually decreases as the point of the nose is reached, the net time being 1 min. 24 sec. All of these lathes are fitted with foot operated platforms under the shell, which enable the operator to set up and remove the work single-handed with slight effort and very little time. The lever extending from the top of the headstock is part of a foot-brake with which every machine throughout the factory is fitted. It is pedal operated, the foot lever being held down by a detent so that the machine cannot be started inadvertently until the operator is prepared.

Base Operations

This work is divided amongst three groups of machines in the following manner:—1st, rough out the counterbore and face the end to a certain high

limit; 2nd, ream the counterbore and portion of bore which is to be threaded; 3rd, tap the thread to fit adapter. The first two operations are performed in boring machines identical in construction with that used for the boring work already described. The cutter heads used are of conventional design, with inserted cutters set for the required diameters. A special cutter is provided which chamfers the edge of the counterbore just ahead of the boring cutters; this is done to prevent the forming of a ragged edge, which would interfere with the removal of pilot bushings for guiding the boring head during this operation. The arrange-

ment of these bars is shown diagrammatically in line drawings, Figs. 8 and 9. In Fig. 9 the smaller set of cutters ream out the body to tapping size, while the larger set ream the diameter of the counterbore and face the

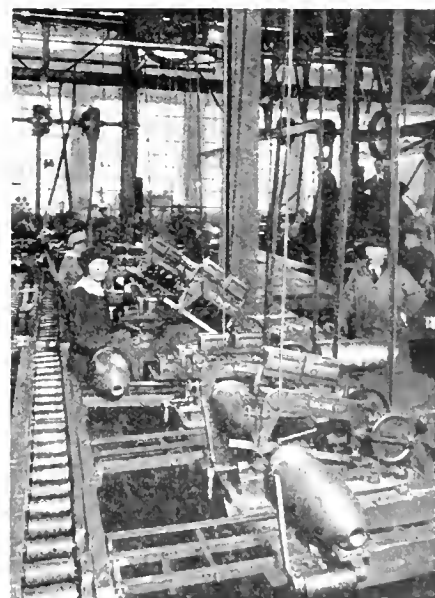

CUTTING SQUARES OFF ADAPTERS IN BATTERY OF HACK SAWS WITH COMPLETE SYSTEM OF CONVEYOR RUNWAYS.

bottom of it to fit properly against the flange of the adapter.

Threading the base is done with Victor collapsible taps and Colburn heavy duty drilling machines. It is divided into roughing and finishing, the tap which does the roughing being fitted with a ball-bearing keyway, which eliminates all driving friction, allowing the tap to enter freely and form a perfect thread without any chance of stripping with unskilled help. The second tap is more of a reamer, and is arranged to take just enough of a cut to insure a good surface on the thread. Both taps operate

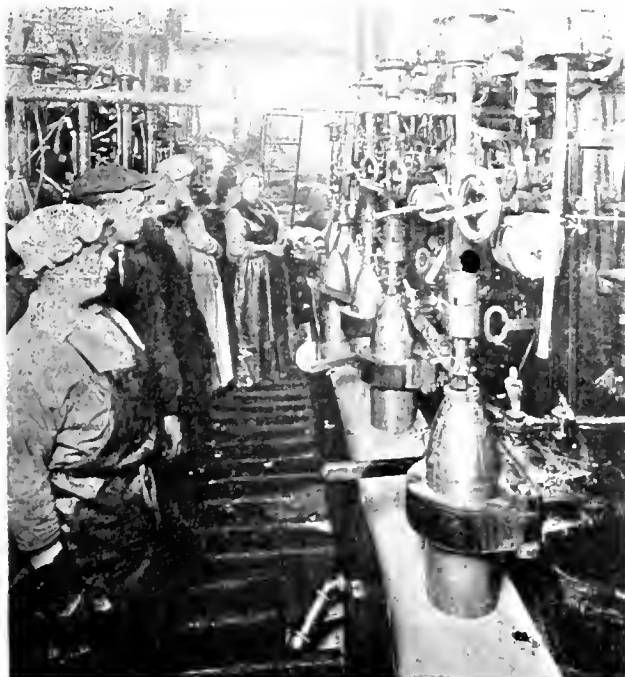

BORING, REAMING, RECESSING AND TAPPING NOSES IN VERTICAL DRILLING MACHINES.

at the same speed, viz., 40 sec. per shell.

All of these drills are fitted with tilting chucks into which the shell is slipped when in a horizontal position, runway rollers being laid in position at each chuck.

Nose Operations

Four separate operations are required to finish the nose, viz., bevel, recess, ream and tap. The tapping is divided into three stages. Six 12 in. Barnes vertical drills are used, each of which does only one part of the work. They are arranged in a row, forming a six-spindle gang drill, and the shells travel past each spindle in succession, being operated on in the order mentioned above. A view of these drills is reproduced on page 211, the three nearest having Murehey collapsible taps with floating drive from the machine spindles. The special chucks fitted to these machines are also shown, the hinged strap being locked by an eccentric lever. Cutting compound is used freely, the table draining back into the shop system which is referred to later. The average time for a shell to pass through the group is just over 6 min.

Washing, Weighing And Gauging

The shells are now placed on two live rollers and revolved at a moderate speed so that the compound and other foreign matter can be rapidly removed from both interior and exterior, blown out with an air jet, gauged and stamped, after which they are washed in lye at 150 degs. and rinsed in water at 110 degs. The tanks containing the solutions are heated by steam jets which are arranged to circulate the liquid in the interior of the shells. An endless conveyor band extends completely around the tanks dipping into each and carrying the shells in and out at a speed which gives an entire immersion of 4 minutes.

After gauging the shells are fitted individually with adapters, a number of special benches being fitted up with racks, and clamping straps which enable the selection of adapters to be rapidly performed with every assurance of the threads being a proper fit in the shell. The necessity of selecting adapters in this manner has been found more satisfactory and quicker than trying to work to very close limits on the threads themselves, as any slight wear on taps or dies, unless detected immediately, causes sufficient variation to necessitate selective fitting anyway, and by handling the problem in the manner described the output of taps and dies can be greatly increased.

Concluding Operations

The component parts of the shell, having now reached a more or less complete state, are submitted for preliminary inspection by government inspectors, who remove the adapter, and inspect every feature of the shell for finish and accuracy, after which the concluding operations are performed. These are of a miscellaneous nature and are all performed in widely

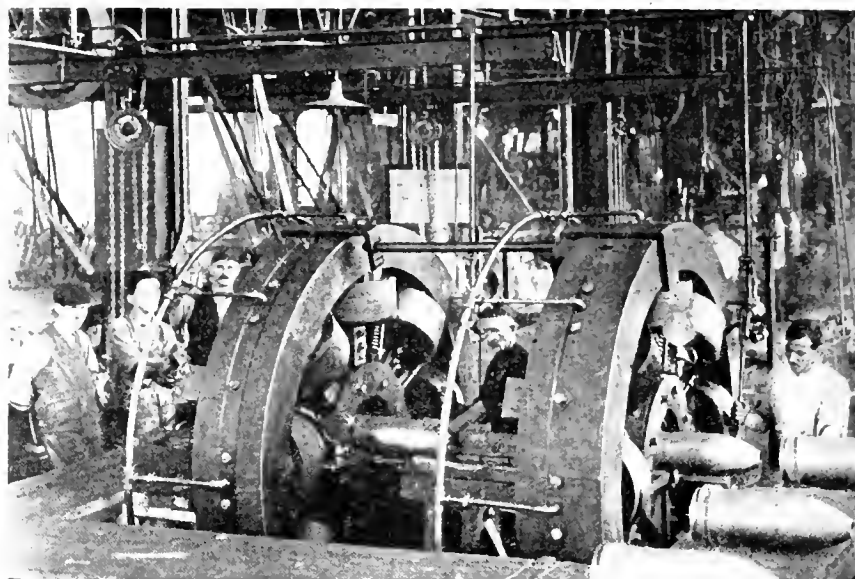

HYDRAULIC BANDING PRESS ARRANGED TANDEM FASHION, WITH CONTINUOUS CONVEYOR SYSTEM.

different machines. Adapter driving, centring, rolling and facing; grooving, banding and band turning; cutting square off adapter, and facing to weight are necessary to complete the machine work, after which varnishing final inspection, and boxing are done.

Adapter Driving Machine

The machines used for this purpose are very similar to the boring machines, and offer still another example of the ubiquitous resourcefulness displayed by the engineering department. By comparing illustration of this machine on page 211 with that of the boring machine on page 209 it will be seen that the general outline is similar, allowing for the views being of opposite sides.

A driving head in the centre carries a square spindle, a clamping fixture holds the shell at one end, and a hydraulic cylinder at the other end feeds the spindle. A square hole in the spindle end engages the square on the adapter, (just noticeable in the picture), and with power supplied by the regular belt drive the adapter is driven home till the belt slips, the feed cylinder keeping the spindle firmly engaged with the square. A ratchet device carried on the spindle end is operated by a vertical cylinder at the back of the shell fixture and of sufficient diameter to put maximum torsion on the adapter. The operator turns on the hydraulic ratchet which makes two or three bites, the entire

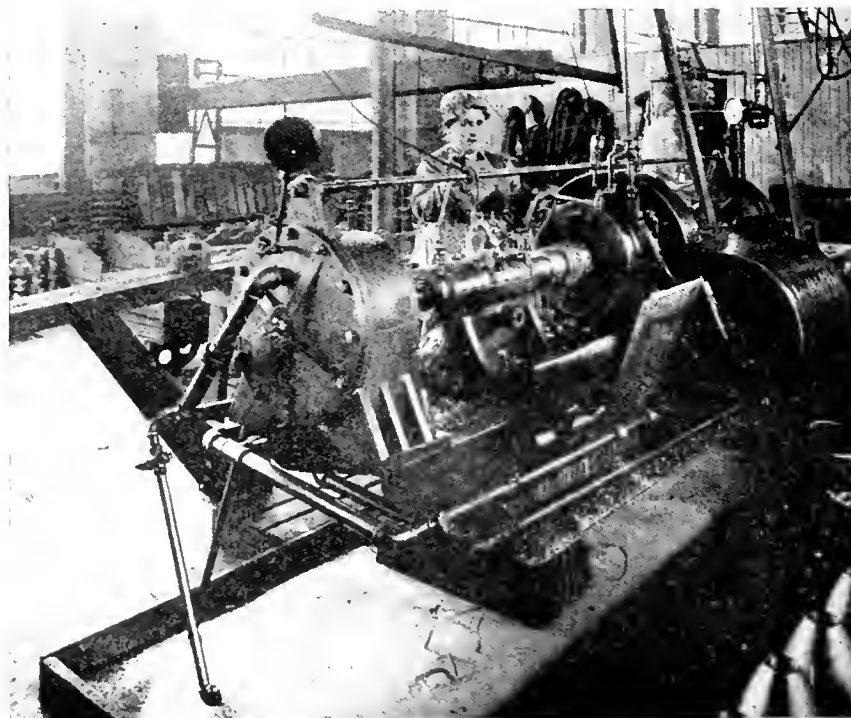

ROUGH TURNING ADAPTER FORGINGS IN CHUCKLESS MACHINE WITH HYDRAULIC CONTROL.

operation, including handling, being completed in less than 2 min.

The subsequent operations are performed in machines of conventional types, all of which, however, are specially tooled according to the particular work required of them.

Tandem Band Press

Considerable interest attaches to the method of using the banding presses. These are of the radial cylinder type with eight cylinders each and are arranged in horizontal tandem fashion with runway level with centre of the frames, see illustration on page 212. The use of two sets of dies was found desirable owing to the width of the band; the dies in the first machine press hardest in the centre of the band allowing the escape of all air and thus insuring proper contact on the waves, while the dies in the second machine spread the pressure out to the sides of the groove and fill the band right into the undercut.

After turning the band profile the shells are handled on individual wooden cradles which travel on a runway extending along a battery of Racine hack saws, shown on page 211. The finished band overhangs the edge of the hinged rack across which the shell is rolled to the saw

when sufficient metal has been removed, and when control valve is reversed a knockout forces the forging up ready for removal by hand. The average output is 40 per hour.

The larger illustration shows the rough turning operation which is further explained by line drawing Fig. 10. The extemporized construction is well shown, driving head, cylinders, I beam bed, and pillow block casting forming arbor guide. The adapter is driven by a socket in the end of square bar into which the square fits. The forging is held in this position by hand with both cylinders full back. The right hand cylinder now advances the supporting arbor, thus clamping the forging firmly between the two ends as shown. By maintaining full pressure on the back of the left hand cylinder and

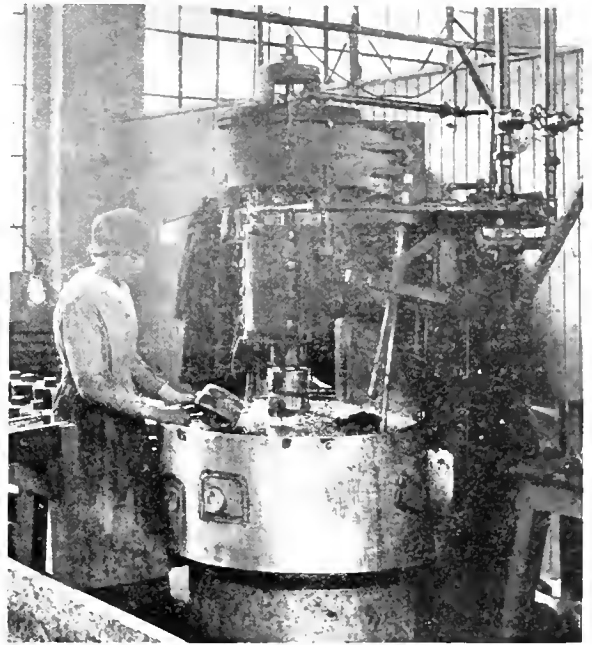

ROUGH FACING ADAPTER FORGINGS IN CONVERTED VERTICAL TURRET LATHE.

square driving bar. The two diameters of the adapter are roughed off by Stellite tools in 1 min. 40 sec.

The subsequent operations on the adapter are completed in turret lathes, thread cutters, etc., the various toolings being of familiar types which call for no special comment.

Hydraulic Power Supply

While no definite mention of the number of machines is permissible, the amount of hydraulic power required is a small percentage of the total power consumed by the machines, 7½ horsepower being sufficient to provide the necessary feeds on all of the machines. The plant consists of duplicate sets,

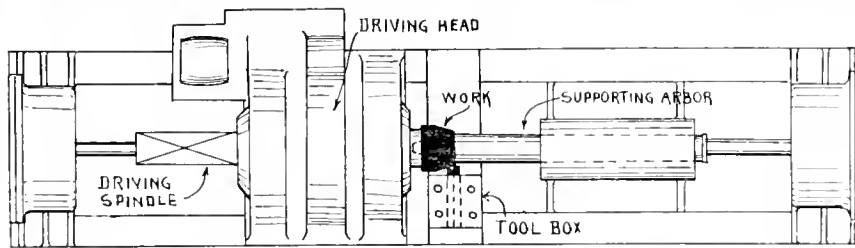

FIG. 10. PLAN OF ADAPTER ROUGHING MACHINE SHOWING METHOD OF FLOATING WORK PAST THE CUTTING TOOLS.

controlling the exhaust from right hand cylinder, the forging floats across the cutting tools while being rotated by the

table. Running from each table to the platform at the back is a short length of conveyor rolls surrounded by an endless belt which travels with the shell and protects the band from damage. Faeng off the base, and adjusting the weight complete the work ready for government inspection before varnishing and painting. An air-drying varnish is used which dispenses with baking ovens. A view of the department where this final work is done is reproduced on this page the shells being under official surveillance until they are shipped direct from this department into railroad cars.

Adapter Operations

The possibilities of hydraulic control of machine tools are further illustrated by two illustrations of adapter machining which follow. The smaller of these shows the initial operation of rough facing, the machine in use having originally been a Bertram vertical turret lathe. The cross-slide mechanism has been replaced by a feed cylinder which forces down a square ram carrying a stationary head with flat cutters. The rough forging is provided with a special square on the back which is dropped into a square hole in the centre of the revolving table, no chucking of any kind being required. An indicating needle informs the operator

controlling the exhaust from right hand cylinder, the forging floats across the cutting tools while being rotated by the

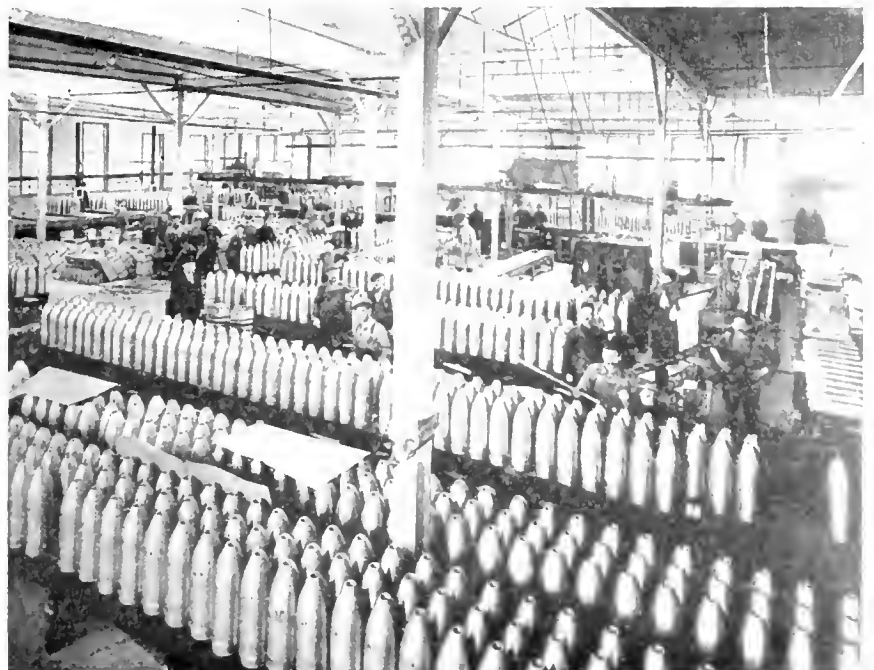

VIEW OF FINISHED SHELLS BEING VARNISHED, PAINTED, INSPECTED, AND BOXED FOR SHIPMENT

one being reserve, Goulds three-throw pumps, 7 in. x 7 in., driven by 30 horse-power motors. Each pump is a unit by itself, with its own receiving tank, two discarded boilers 72 in. x 12 ft. being used for this purpose.

These tanks are kept about half full with compressed air connections for providing the initial air space. The liquid used is straight cutting compound, and all leaks, bye-passes, cooling streams, etc., drain into a common return tank from which the pump suction is taken.

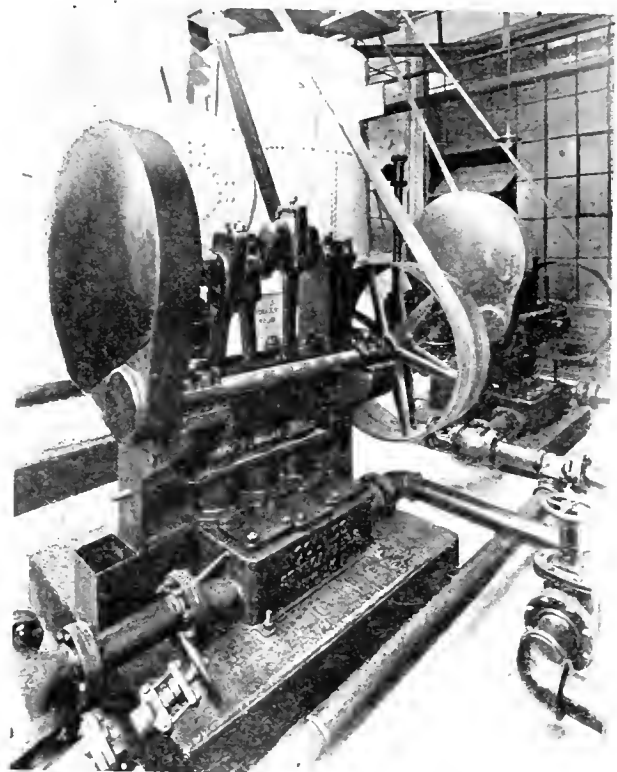

DUPLICATE POWER PUMPING PLANT WHICH SUPPLIES HYDRAULIC POWER FOR OPERATING THE MACHINES DESCRIBED IN THIS ARTICLE.

BRITISH SHRAPNEL MANUFACTURE IN CANADA

THE Canadian Commercial Agent at Petrograd, Russia, C. F. Just, writing to the Department of Trade and Commerce, Ottawa, says it will interest Canadian munition workers to know that a Petrograd publishing house has recently added to its series of technical publications an interesting booklet entitled, "The Manufacture of English Shrapnel in Canadian Factories." The authors, Messrs. Sdzitovesky and Bekker discuss at length how promptly and with what ingenuity the equipment of Canadian works was adopted to the production of munitions, and, incidentally also, the resources, inentiveness and the enthusiasm displayed by the workers in tackling and solving the difficulties of manufacture altogether new to their experience. The book is very fully illustrated with cuts and detailed drawings of the tools, and of specially designed tool parts employed, accompanied by explanatory text of the operations for securing desired results and the general methods of manufacture. The publication will no doubt

serve as a good advertisement in Russia of Canada's progressive industrial methods. A copy can be seen at the Department of Trade and Commerce, Ottawa.

MIS-USE OF GAUGES

By R. Hamilton

A FACTOR having considerable bearing upon the incidental expenses contingent to the production of shells is the maintenance of the various gauges required for the accurate machining of the parts to specified dimensions. Owing to the variety class of men now employed in munition plants, and the limited knowledge that many of them have of the actual value of precision tools, it is not surprising to see the latter misused on many occasions. Shell operators should more clearly and fully realize the importance of these test pieces, giving more attention to the handling of the same, so that their accuracy may be longer maintained. Just recently, while passing through a large shell-making plant, I noticed a young fellow using a 2 inch limit plug gauge as a hammer to force a cutting tool to a desired position.

The practice of placing a gauge as a hammer to force a cutting tool to a desired position: eter gauge on the shell, before the lathe is stopped, has a destructive effect upon the gauge, as well as tending to possible injury. Owing to the comparatively rigid construction of these tools they do not possess the spring that is so marked in the ordinary calliper and, when a shell is somewhat oversize, a seizure of the gauge results very easily, if the shell is in motion. Inexperienced operators often believe that time is saved by placing the gauge on the work just previous to its coming to a stop. Sometime ago, an operator was seen prying a large 8 inch snap gauge off a shell by using a 14 inch spanner as a hammer and lever. After removing the gauge he cautiously tried it on a finished shell and found that the high limit size would pass over. This meant that the gauge had to be returned to the tool room to have the size corrected. Instances similar to these here related mark the misuse of precision gauges in many plants, and greater attention should be given to the instruction of operators in the proper handling and care of these expensive tools.

WON'T LEAVE UNITED STATES

RUMORS that the Nathan Manufacturing Co. would move their entire fuse making department, employing upward of 3,000 men, to Canada, has been emphatically denied by Alfred Nathan, president and head of the concern. "We are far too patriotic to close up this end of our business while the United States stands in such an uncertain and critical position," Mr. Nathan announced. "If our own Government needs the resources of our company they most certainly have the first call on them."

In explaining the fact that two car-loads of machines used in the manufacture of time fuses for shells had recently been shipped to Toronto and that O. Best, general manager of the factory, had left for that city, Mr. Nathan said:

"Most of our foreign munitions contracts have been completed and these machines that were sent were extras that we had no use for. They comprise only a small fraction of our equipment and would have very little effect on our possible output. The simple truth of the matter is that we had a chance to sell them to advantage and at the same time return a favor to an associate who helped us when we started into this business a couple of years ago."

Mr. Best, the factory manager, will investigate business conditions in Canada, with the possible idea of establishing a branch factory there, however. Mr. Nathan conceded. Unless the United States should need the fuse product, Mr. Nathan intimated that this branch of the business would be discontinued when the company moved into its new factory at Flushing next month.

The business originally was limited to the manufacture of ejectors, whistles, oil cups and general locomotive equipment. Since the war started, the munitions end has overshadowed the other branches.

Abrasive Materials.—Experiments recently conducted with abrasive materials used as powder for lap grinding showed that the initial rate of cutting was not greatly different for the different abrasives tested, but carborundum maintained its rate better than others, alundum was next, and emery the least satisfactory. Carborundum, however, was found to wear the lap about twice as fast, and alundum $1\frac{1}{4}$ times as fast as emery. It was also proved that the rate of cutting is practically proportional to the pressure. The materials upon which the work was done influenced the wear of the laps, which was in the following proportions: Cast iron, 1.00; steel, 1.27; copper, 2.62. Petrol and petroleum are the best lubricants to use with cast iron lap, the latter, on account of its non-evaporative qualities, being first choice. Machine and lard oil were found to be the best lubricants to use with a copper or steel lap, and lard oil with all laps and all abrasives tested.—the cutting being faster than with machine oil.

CRUDE OIL INSTALLATION FOR SHELL FURNACE

By M. W. Minster.

THE furnace, the oil burning installation of which is herein described, was built and used for heating 4.5-in. Mark VII. H.E. shells previous to the closing-in operation. The fuel used was crude oil, which at ordinary atmospheric temperatures is thick and very viscous, and for proper combustion requires to be heated. Storage was provided outside the building, the tank being located, as required by the insurance regulations, not less than five feet from the nearest wall, and with at least four feet of dirt over it. A 2-in. filling pipe led from the tank to above the ground, and a 1½-in. suction pipe connected the tank and pump. The pump was of the geared type, belt driven, and having 1-in. suction and discharge. The large suction pipe was provided on account of the viscosity of the oil.

In the discharge line from the pump, a spring loaded relief valve was provided, the discharge from the relief valve being piped back to the tank. In the relief pipe, a vent was provided leading to above the eaves of the building and terminating in a return bend. The object of the relief valve was to provide a means of regulating the pressure of the oil to the furnace, the pump speed being constant.

Constructional Principle

The discharge from the pump was a ¾-in. pipe, and was connected to a main heater. The heater was constructed on the principle of the ordinary kitchen boiler. The reservoir consisting of a piece of 8-inch pipe, about four feet

long, closed at each end with a cap. A heating element, composed of three lengths of ½-in. pipe wound into coils and welded together, was inserted in the reservoir with the ends projecting through the upper cap. A city water connection was provided in the upper cap, also a pipe leading to a relief valve and a bleeder valve, the latter to bleed out a portion of the hot water if there was a tendency to form steam in the reservoir. The heating surface was provided by a loop of 1-in. pipe starting from the bottom of the reservoir, and after passing across the top of the furnace, returning to the reservoir.

After leaving the main heater, a starting heater was installed in a by-pass in the oil line. This heater was made up of one length of ¼-in. pipe wound into a coil about 3 in. in diameter; after being connected up, the coil was enclosed with blocks of asbestos 2 in. thick to retain the heat. Just beyond the by-pass a high pressure steam thermometer was installed in a cross, and beside the thermometer a strainer was provided. The strainer consisted of a brass shell, having a copper gauze basket inside. The inlet led into the basket, which retained the fine particles of solid matter. The basket was readily taken out for cleaning by removing a plug in the top of the strainer.

After leaving the strainer, the oil pipe branched, one branch leading to each end of the furnace, where the burners were located. A connection for a pressure gauge was provided where the oil pipe divided, thus giving the pressure actually on the burners. Shut-off valves were provided at each burner, the latter being connected up with unions to facilitate

removal. The burner consisted of a 4-in. T, the branch of which was connected up to the air supply from a pressure blower. One end of the run of the T was connected to the burner opening in the furnace wall, the other end being closed with a plug. Through the centre of the plug a ⅜-in. pipe was passed, the outer end being connected to the oil supply by a ¾-in. angle valve, from which the valve was removed and the thread cut off the spindle. On the inner end was screwed a hollow casting with a double thread cast on the outside. The top of the thread filled the T, and formed a helical passage for the air.

The oil passed through the casting and entered the tip which was screwed into it. The tip was bored out to two sizes, the side screwed into the casting being ¼-in. diameter, which was reduced to 1/32 in. where the oil discharged. Leading to the small hole was a helical passage formed by inserting a small slug, on which a double square thread was cut into the ¼-in. part of the hole. As the helices of the oil and air passages were of opposite hands, the oil and air revolved in opposite directions when discharged into the furnace, greatly assisting combustion. The small slug was tapped to receive a piece of ⅜-in. wire, the other end of which was screwed into the spindle of the ¾-in. angle valve. This construction enabled the slug to be moved out and in by hand from its working position, and, acting as a pump, often cleared a slight obstruction in the tip.

Starting Up

Starting up was carried out as follows: The oil pump was started and the relief valve on the oil line regulated until the desired pressure was reached. The pressure in this particular instance was from 35 to 40 lbs. per sq. in. A coal oil torch was then directed on the small starting heater, and, as the coil and its contents became heated, cold oil was drawn out at the burners. This oil was, of course, saved and returned to the supply tank. As soon as the oil temperature at the burners was up to 150 deg. F., or thereabouts, a piece of waste soaked in coal

CRUDE OIL FURNACE INSTALLATION FOR HEATING 4.5 INS. MARK VII H.E. SHELL PREVIOUS TO CLOSING-IN OPERATION.

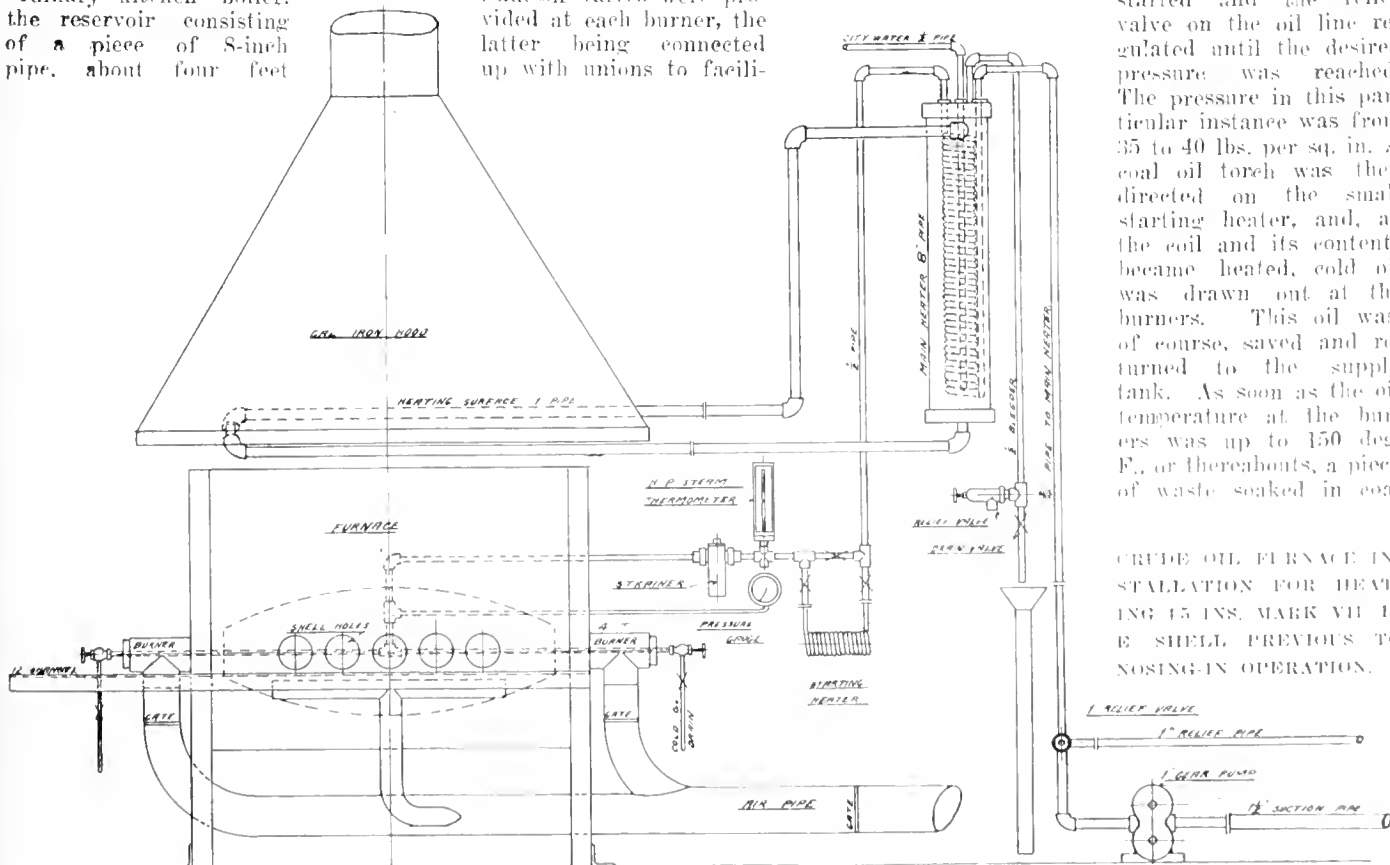

oil was thrown into the furnace and lighted, and the oil turned on to the burners. If the oil was hot enough and atomizing properly it would ignite immediately. The blower was then started and air admitted to the burners.

Air Supply

The amount of air supplied was regulated to suit the quantity of oil necessary to produce the required temperature in the furnace by gates in the branches to the burners. It was delivered at 10 oz. pressure from a blower running at 3,200 r.p.m. As the furnace warmed up, and the main heater became operative, the starting heater by-pass was closed and the oil temperature allowed to rise to about 225 deg. F. The hot water bleeder was then opened and regulated, so that a temperature of from 225 to 250 deg. was maintained.

The size of the fire was not regulated by the valves in the oil supply line, but by the relief valve on the pump discharge. Increasing the oil pressure increased the amount of oil passing through the burners, and consequently increased the size of the fire. After the furnace was warmed up properly, the time required to heat a shell was from 6 to 7 minutes. When shutting down for more than a few minutes, it was necessary to remove the burners to prevent the oil in them from baking, due to the radiant heat from the brickwork. As the burners could be removed in less than half a minute, this item was a small matter. The equipment was designed and installed under the supervision of E. C. Fogh, of the Machinery Installation & Contracting Co., Vancouver, B.C.



BASE PLATE CHUCK FOR 4.5 INS. H. E. SHELL

By H. A. W.

THE chuck shown in the accompanying line sketch has given excellent satisfaction in production, and has rarely called for repairs and adjustments. The main body of the chuck is made from a good grade of machinery steel unhardened. The nut is also made from good machinery steel, but is pack-hardened. A little

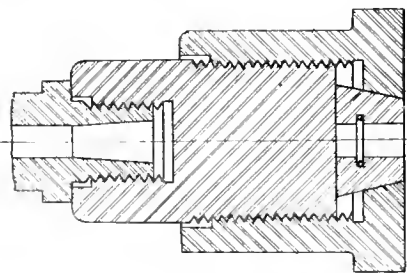

BASE PLATE CHUCK FOR 4.5 INS. H. E. SHELL.

base plate nib. The jaws are made from carbon tool steel and hardened. Base plate nibs are forged with a taper which varies a little in different plants. Roughly, the height of the nib is $\frac{7}{8}$ of an inch, $\frac{7}{8}$ ins. square at the base and $\frac{3}{4}$ ins. square at the top end. The jaws are made to close to the above dimensions, but in order that they may accommodate themselves to a slightly different taper when necessary, the outside of the jaws is not turned a straight taper. Their surface is slightly convex, and this enables them to rigidly tighten on base plate nibs quite widely different in their tapers.

As shown in the sketch, a groove is turned at the back of the serrated surface where a small piece of music wire is placed to prevent the jaws from closing together when a plate is removed, and making it troublesome to insert another plate. In service this chuck has turned thousands of base plates, some very irregular, and we have yet to hear of one plate that has shifted under the cutting tools.



DON'TS FOR SHELL OPERATORS

by J. R. M.

DON'T throw a shell down unless you see where it is going to fall.

Don't use a steel rule to pick off the scale on a rough forging.

Don't force a gauge over the work; it will destroy its accuracy.

Don't try to rectify a damaged gauge; take it to the tool room.

Don't forget that good work cannot be performed with dull tools.

Don't use lighted matches if cleaning shells with benzine or alcohol.

Don't forget to keep your machine well oiled; like yourself it needs occasional feeding.

Don't leave gauges lying where a shell might chance to fall on them.

Don't let your gauges lie on heated or frost covered shells; the size will be effected.

Don't forget that co-operation with your mate on the other shift means better work and more of it.

Don't start work on a new machine

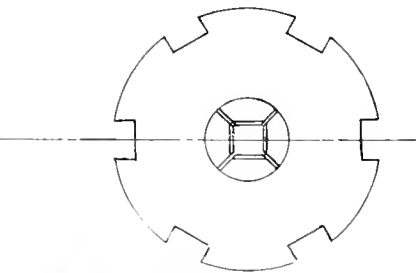

until you become familiar with the operating mechanism.

Don't permit your tools to become over-heated when grinding as their cutting qualities may be destroyed.

Don't leave your machine in a state of disorder at quitting time, remember you will be starting again in the morning.

Don't try to clean out with your fingers the cuttings from the small hole in the shell nose; your fingers may easily be injured.

Don't allow tools, etc., to accumulate on the saddle of the lathe, as they may easily fall off and interfere with its travel.

Don't make a practice of gauging the work while in motion; the gauge may seize and result in injury to your hands; besides, the rough surface of the shell would soon wear the gauging point and destroy the original size.



AUSTRALIAN STEEL FOR IMPERIAL GOVERNMENT

AS much as possible of Australia's production of steel is to be exported to Great Britain while the need exists, says *Australian Hardware and Machinery*. It is to take the form of steel rails and fish-plates, and the available quantity is 50,000 tons for the first six months of 1917. Intimation to the above effect was made in the Commonwealth Parliament by the Prime Minister.

The only producers of such materials in Australia are G. & C. Hoskins Ltd., of Lithgow, and the Broken Hill Proprietary Co., who recently established iron and steel works in the neighborhood of Newcastle. A sample shipment of 500 tons of shell steel went from the Broken Hill Co. to the Imperial authorities early in 1916, and brought an order for a further 1500 tons, which the company had in stock, followed by a request for 10,000 tons of round mild steel bars for munition purposes, over 2000 tons of which have been shipped.

The Ministry of Munitions then asked the Federal Government for the estimated steel output of Australia during 1917 (in separate half-years), and how much of this could be spared for munition requirements. The Premier was told by the above-mentioned two manufacturing concerns that the production would probably be 120,000 tons for the first half and 110,000 tons for the second half of the year. As already stated offer was made to furnish 50,000 tons for war requirements during the first six months, the second six months' supply to be arranged later. In subsequent cablegrams the Ministry of munitions sought a quotation for 75-lb. steel rails and fish-plates delivered in Britain and France, and for the present the material to be supplied will probably take this form.

The 50,000 tons of steel is the small half of the Australian output. Every ton was already pledged to the Federal and State Governments, and only by interrupting work already in hand or deferring contemplated enterprises will the Australian Premier be able to redeem his promise. No doubt the country will stand behind him in the matter. While directly helping the cause of the Allies, it will tend to reduce Australian expenditure, and increase Australian exports. By responding to the call of patriotism, not two, but three, birds will be killed with this one stone.

kink to protect the thread on the chuck body is to make the threaded portion of the nut considerably longer than the length of thread on the body and then counterbore the nut, thus keeping the dirt and chips out of the threads, no part of same being exposed.

There are four jaws, these being deeply serrated on the faces that grip the

Manufacturing Brass Cartridge Cases

For Shrapnel
and
High Explosive
Shell

Staff Article

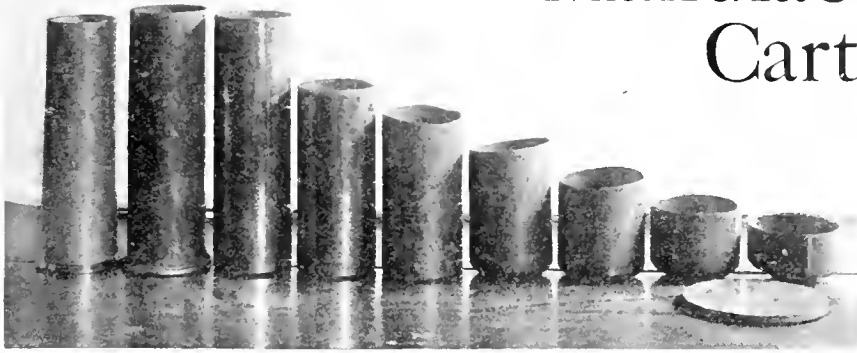

The manufacture in Canada of brass cartridge cases for service with 18-pdr. shrapnel, 18-pdr. and 4.5 inch high explosive shell, was in its initial stages no less beset with difficulties than was that of shell bodies, fuzes, etc. As in the case of the latter, the firms undertaking production achieved early success, however, and have, without interruption, continued to add to it in very material degree; so much so, that, although fewer in number comparatively, they are easily able to meet the requirements of finished shell of the above types and sizes.

TO the layman visiting a plant where brass cartridge cases are being manufactured, the process might appear to be simple, although extremely interesting. As a matter of fact, however, the production of cartridge cases calls for considerable skill in the design of the tools employed, and satisfactory results have only been obtained by concentrated effort in overcoming the numerous difficulties that in the first instance confronted manufacturers of this product. The extreme accuracy required in the size of cartridge cases and consistency in the quality of metal require that the greatest care be exercised in their manufacture. For these reasons their production is not such a mechanical affair as the uninitiated might think. The efficiency of a plant and, therefore, its output, are, of course, greatly increased by the use of modern machinery. At this plant the equipment is all of the latest type, its general efficiency being of a high order. The buildings, too, are of modern construction and are planned expressly for the purpose for which they are being utilized; truck-

ing and handling being thus reduced to a minimum. The ground plan, illustrated, shows the general lay-out features.

dises, approximately 750,000 cases can be produced each month. The cartridge cases are, of course, made to standard

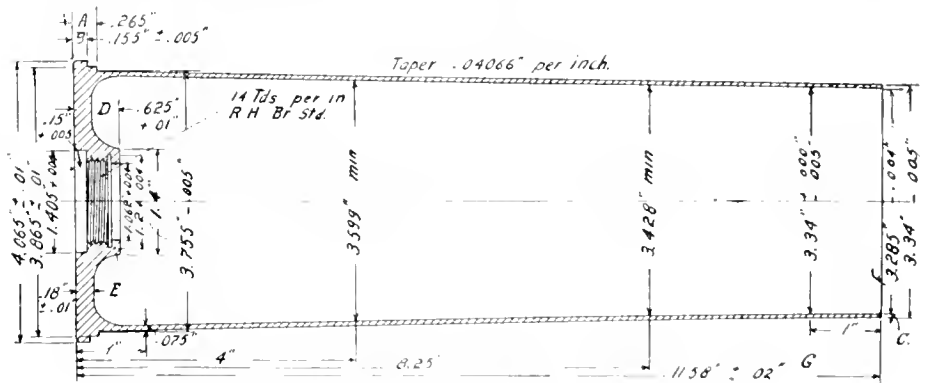

SKETCH OF BRASS CARTRIDGE CASE FOR 18-PDR. SHELL.

Production Capacity

At the plant which is the subject of this article, 18-pdr. shrapnel and high explosive, and 4.5 ins. howitzer brass cartridge cases are being manufactured, and with a sufficient supply of brass

Government specifications, the practice followed does not, therefore, differ materially from that of other concerns in the number of drawing operations, except in a few details—some more or less important—and in the methods used in handling the work. The metal from which the cartridge cases are made is an alloy of electrolytic copper and zinc, being in the proportion of approximately two parts of copper to one of zinc. The metal possesses very high tensile strength when annealed and of the proper hardness; this feature will be dealt with later. The brass discs for the 18-pdr. shell case are 6.062 ins. in diameter and 0.380 in. thick. They are not made in this plant, but are purchased from various outside concerns who make a specialty of them. The discs are generally annealed in the maker's mill, and are thus ready for the first, or cupping operation when received at the cartridge case plant.

The manufacture of cartridge cases consists primarily of a series of drawing



18-PDR. CARTRIDGE CASE WITH DRAWING CLIP ATTACHED.

This is among the millions accessories being made in Canada, and forms an interesting job of blanking, piercing and drawing.

out and pressing operations, the former to make the body of the case and the latter to form the head and indent in same for the primer. The presses which are practically all of Bliss or Toledo make, are powerful machines and are

The pans or trays hold from 200 to 120 cases, the number being reduced as the stage of manufacture progresses. The cases are carried to the furnace on trucks. The pans are fed into the furnace at the loading end by means of a

pusher operated by compressed air. At the end of the prescribed period, the pans are pushed out at the discharge end into trucks and wheeled away to be cooled slowly in the yard outside. During the cooling process, the cases are protected from the weather by overhead verandahs. The furnaces are worked at a temperature ranging from 1,160 to 1,110 degs. Fah., according to the stage of operations, while the time occupied for annealing varies in the same way, and ranges from 56 to 30 minutes. The scleroscope tests will be dealt with later. In each furnace is a Bristol electric pyrometer connected to registering and recording instruments for determining temperatures. The operating pyrometers are tested frequently by a mas-

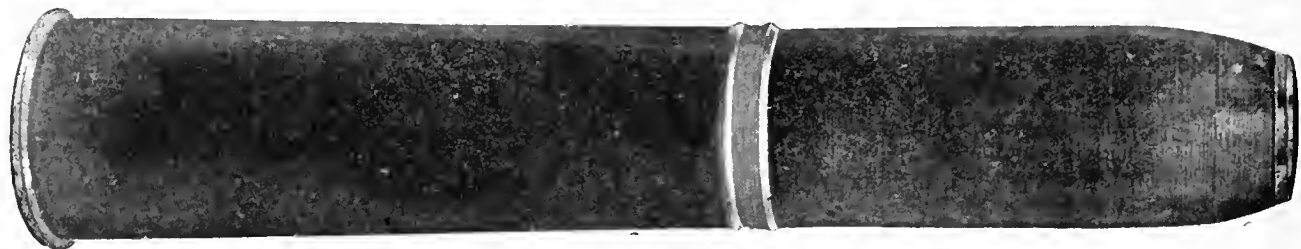

BRASS CARTRIDGE CASE WITH 18-PDR. SHRAPNEL SHELL INSERTED.

driven from the line shaft by electric motors.

Annealing and Pickling Features

Before proceeding with a description of the main operations, reference should be made to the annealing and pickling, etc. The brass case is worked up in a cold state. The drawing and indenting tends to harden the metal somewhat, consequently annealing is necessary to restore the required ductility. The 18-pdr. cases are annealed five times; the sequence of anneals will be seen later. The annealing is done in furnaces which are all standard Rockwell type equipped to burn natural gas or fuel oil. There are six furnaces, four 6-burner, and two 4-burner; the larger furnaces hold six pans, and the smaller four pans, at a

pusher operated by compressed air. At the end of the prescribed period, the pans are pushed out at the discharge end into trucks and wheeled away to be cooled slowly in the yard outside. During the cooling process, the cases are protected from the weather by overhead verandahs. The furnaces are worked at a temperature ranging from 1,160 to 1,110 degs. Fah., according to the stage of operations, while the time occupied for annealing varies in the same way, and ranges from 56 to 30 minutes. The scleroscope tests will be dealt with later. In each furnace is a Bristol electric pyrometer connected to registering and recording instruments for determining temperatures. The operating pyrometers are tested frequently by a mas-

First Operation—Cupping

To return to the first cupping operation on an 18-pdr. cartridge case, the brass disc is placed in the press and is forced through the dies, forming it into the shape of a cup. One man at this operation can produce from 380 to 400 cups an hour. The first annealing operation is now performed. About 200 cups go to a pan. They are kept in the furnace for 56 minutes at a temperature ranging from 1,150 to 1,160 degs. Fah.; after cooling, the cups are pickled and washed, according to the method already described.

Second Operation—First Re-draw

This operation is similar to the preceding one. The sides are increased in length and reduced in thickness, but the bottom of the case remains the same. The production is practically the same as for cupping, viz., 380 to 400 an hour. The cases are again annealed, pickled and washed, the annealing requiring the same time, and being carried out at the same temperature as in the first operation.

Third Operation—Second Re-draw

The second re-drawing operation is identical with the first, the sides being, however, further lengthened and reduced in thickness; the bottom as before remains the same. Production is on a like basis as that for the previous operations. During these three operations it is imperative that the bottom of the case be not reduced, as the full thickness of metal is required to form the head and indent. Annealing is not necessary at this stage, so the cases are taken over to the indent press.

Fourth Operation—First Indent

In this and the succeeding indenting operation a change is made in the character of the dies employed. In each of the three preceding operations, the embryo case was forced through a circular die by a punch traveling vertically downwards. In this, the fourth operation, the first indent, for the primer pocket, is formed in the head, the indent when finished being machined to take the percussion primer. The case is placed over a die, the head of which conforms to the shape of indent inside the case, while the projection on the punch forms the indent proper. Two men are

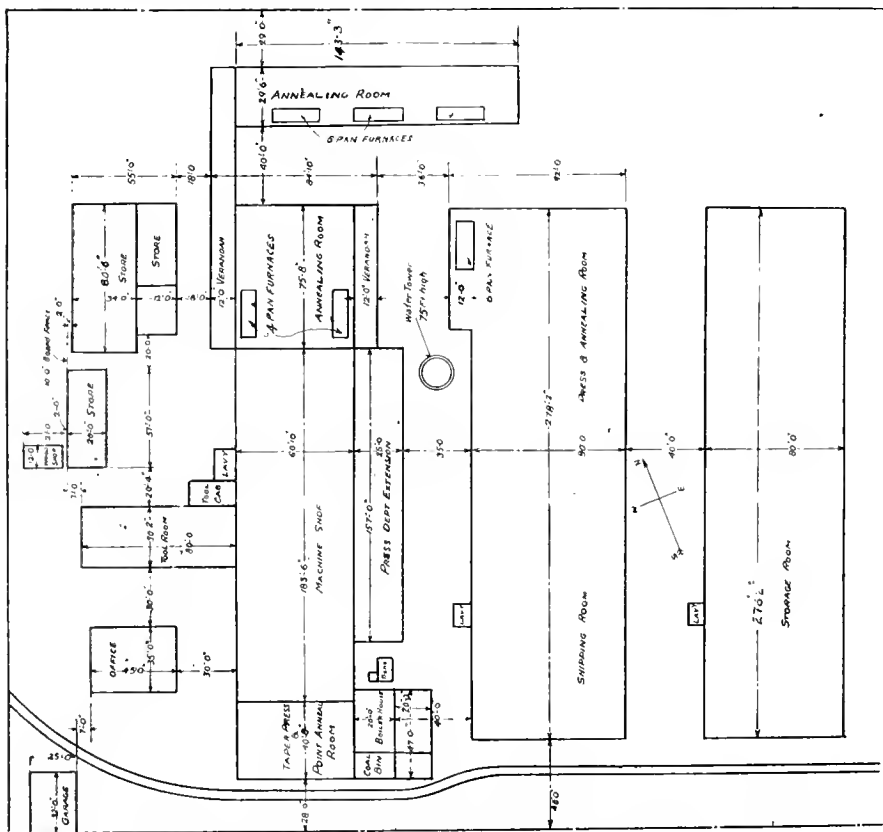

DEPARTMENTAL LAYOUT OF CARTRIDGE CASE MANUFACTURING PLANT.

time. The oil is conveyed to the furnaces from two 15,000 gallon underground tanks, by means of a Rockwell rotary pump operated by a 3/4 h.p. C. G. E. induction motor.

ter pyrometer to eliminate any possible error in registration. The cases, after being annealed, are pickled to remove any scale that may have formed on the surface of the me-

required for this operation, and the production is about 250 per hour. The cases are again annealed, pickled and washed. For annealing, about 165 cases constitute the contents of a pan, and the time occupied is 51 minutes, at a temperature ranging from 1,130 to 1,140 deg. Fah.

Fifth Operation—Third Re-draw

The procedure adapted for the third re-draw, and the dies also, are very similar to the preceding drawing operations, except that the end of the punch is recessed so as not to touch the indent. At this operation, the production is about 200 cases per hour with two operators. The cases are again annealed, pickled and washed. The annealing takes 42 minutes, at a temperature of 1,110 to 1,120 degs. Fah., the pan holding 160 cases.

Sixth Operation—Fourth Re-draw

The fourth re-draw is performed in a manner similar to the above operation, the same type of punch and dies being used. The case has now considerably increased in length, and production is reduced to 150 per hour with two operators. The second indenting follows, and is similar to the first indent operation except that the head is flattened a little. Two operators are employed at this

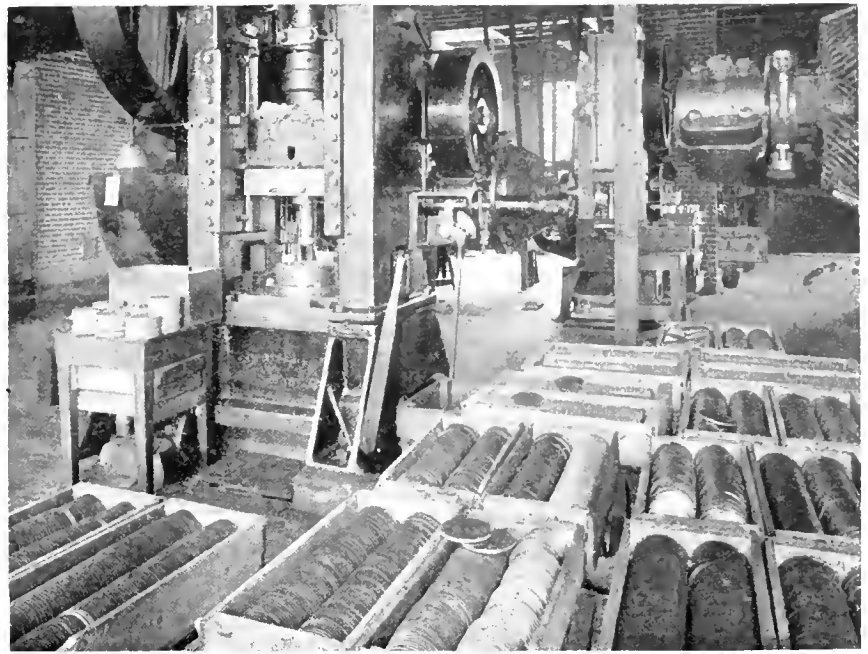

TYPICAL CUPPING PRESS, WITH BOXES OF BRASS DISCS IN FOREGROUND READY TO BE OPERATED UPON.

operation, and the production is about 250 cases per hour. The cases—120 in a pan—are again annealed, pickled, and

washed. The annealing occupies 36 minutes in a temperature of 1,110 to 1,120 degs. Fah.

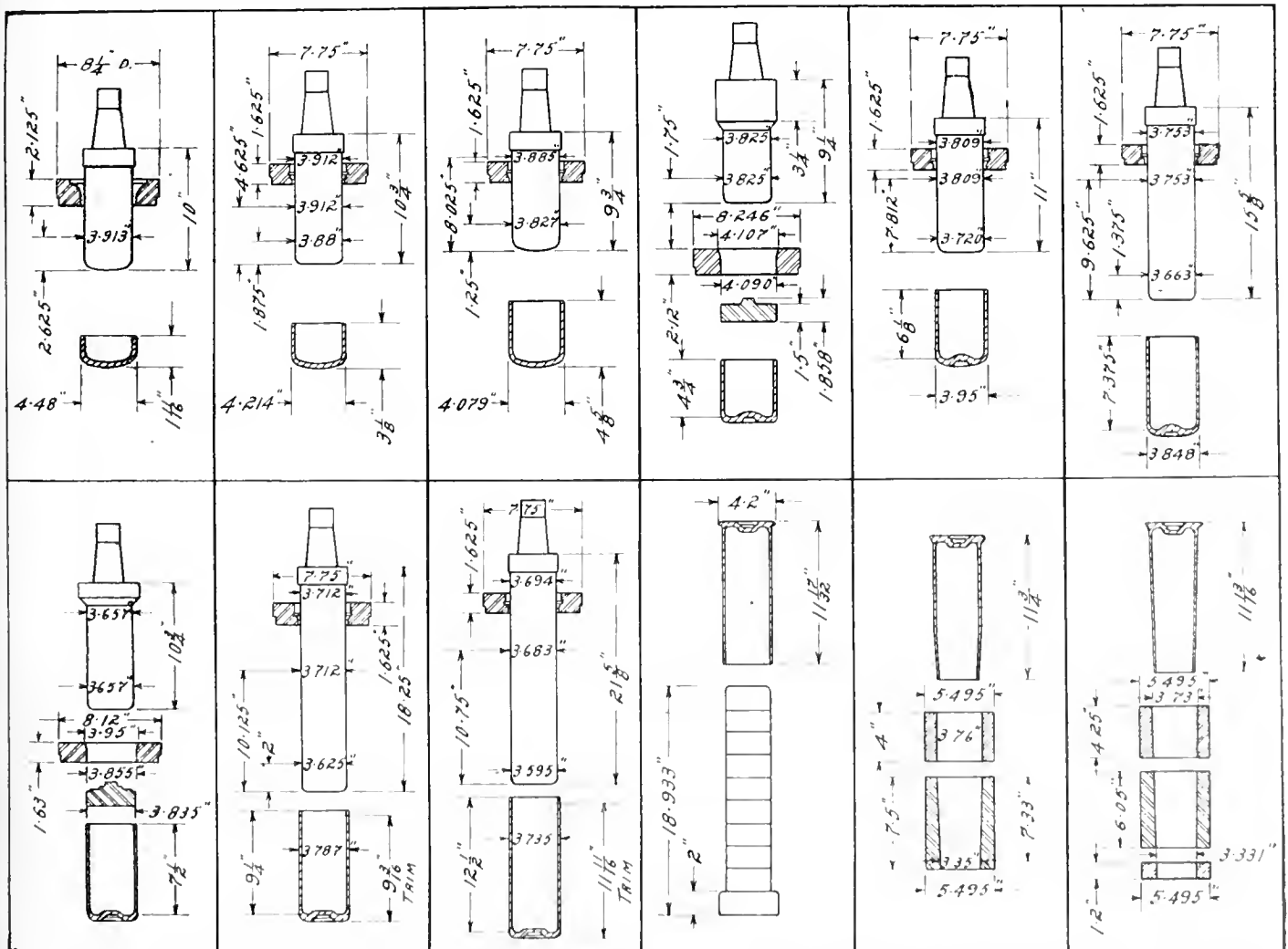
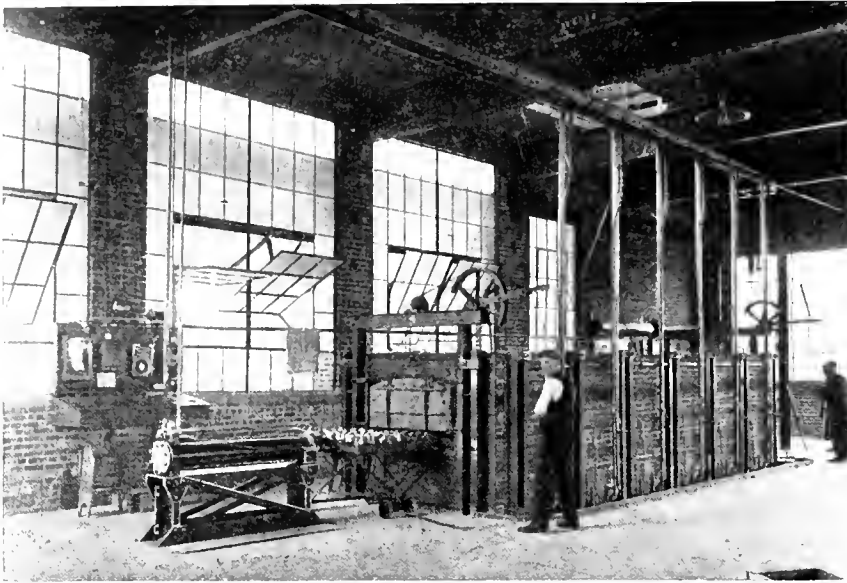

DIAGRAM SHOWING 18-PR. CARTRIDGE CASES DURING THE VARIOUS STAGES OF MANUFACTURE, ALSO THE DETAIL OF PUNCHES AND DIES REQUIRED FOR EACH OPERATION
 Top Row, left to right—Cupping, first draw, second draw, first indent, third draw, fourth draw. Bottom Row, left to right—Second indent, fifth draw, sixth draw, heading, first taper, second taper.



TYPICAL "ROCKWELL" 6-BURNER ANNEALING FURNACE INSTALLED, SHOWING PAN LOADED WITH CASES BEING FED INTO FURNACE BY AIR PUSHER. DUPLICATE PIPES AT SIDE ARE FOR FUEL OIL OR NATURAL GAS.

Eighth and Ninth Operations—Fifth and Sixth Re-draws

There now follow two re-drawing operations, further lengthening the case, with a corresponding decrease in production. The punch and die employed in each case is the same. The production at the fifth re-draw is 150, and, at the sixth, 120 cases per hour. After the fifth re-draw, the cases are trimmed, then annealed, etc. The number of cases per pan is 120, and the time occupied is 30 minutes in a temperature of 1,110 to 1,120 degs. Fah. After the sixth re-draw, the cases do not require annealing again, but they are trimmed; in other words, the ragged edges are removed. The sixth draw increases the length of the case to about 13 $\frac{3}{8}$ ins., the trimming reducing it to 12 ins.

Heading

The re-drawing operations have now been completed, but the head still remains to be formed and finished. The heading is done on a powerful press fitted with two sets of punches and dies, one used for flattening the head, and the other for the final heading which includes forming the primer pocket. The ram of the press has an indexing fixture carrying the two punches, while the revolving table in the press has also an indexing fixture carrying the heading die holders. A case is first placed over the plug in the die which is indexed round until it is in line with the flattening punch. The press is operated and the head flattened out. The die holder now remains stationary while the head-

ing punch is moved into position. The press is operated again, finishing the heading. The table is then moved round bringing the first die holder to the front and the second to the back to repeat the operation on the next case. The press is fitted with an appliance for ejecting the headed case. The production is about 450 cases per hour with three operators.

Flash Annealing and Tapering

The following constitute the tenth and eleventh operations. The sides of the case at this stage of manufacture are parallel, but must be tapered, the mouth having to take the base of shell which is of smaller diameter than the bore of the gun. Before tapering, it is necessary to anneal the case to allow of the diameter being reduced without buckling. The method adapted at the plant under review is known as flash anneal-



TYPICAL HEADING PRESS.

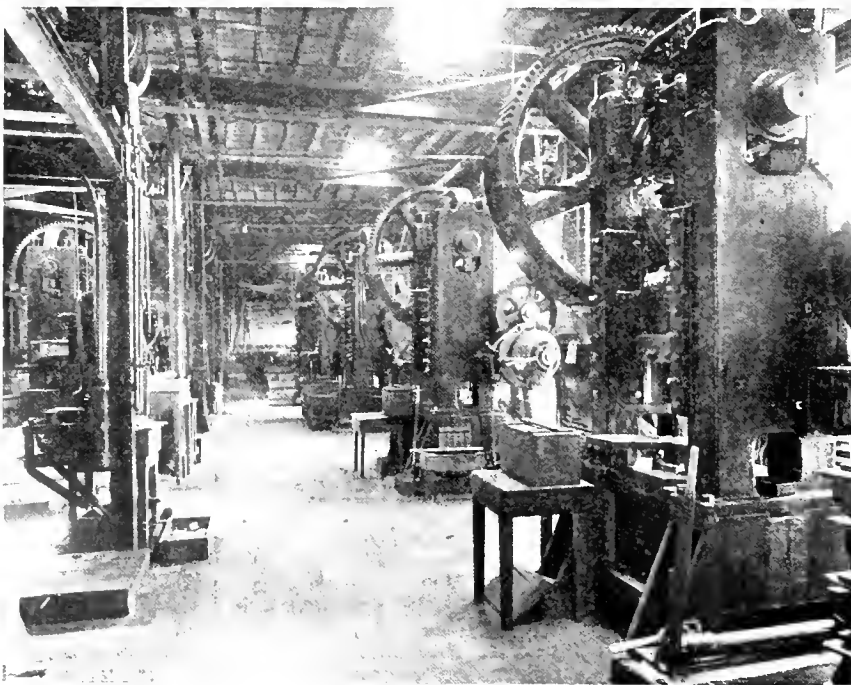

HEAVY DRAW PASSES FOR EARLIER DRAWING OPERATIONS.

ing and consists of heating the cases while they are in motion. The machine comprises a revolving table carrying the cases outside and round a series of gas burners. The mechanism is arranged so as to rotate each case on its own axis while the table is in motion, thus heating them uniformly and continuously. The table travels slowly, but the cases rotate at a much higher speed.

After annealing, the cases are taken to a press to be tapered, this being done in two operations. In the first, the mouth of the case is reduced to 3 $\frac{1}{8}$ ins. in diameter, the length of the taper being about 7 ins., at which point the diameter is 3 $\frac{5}{8}$ ins. In the second operation, the mouth is made straight for a distance of 1 in., and is then tapered from that point to the rim on the head, making a gradual taper of 0.04066 of an inch for every inch in length. For each tapering operation, two men are employed;

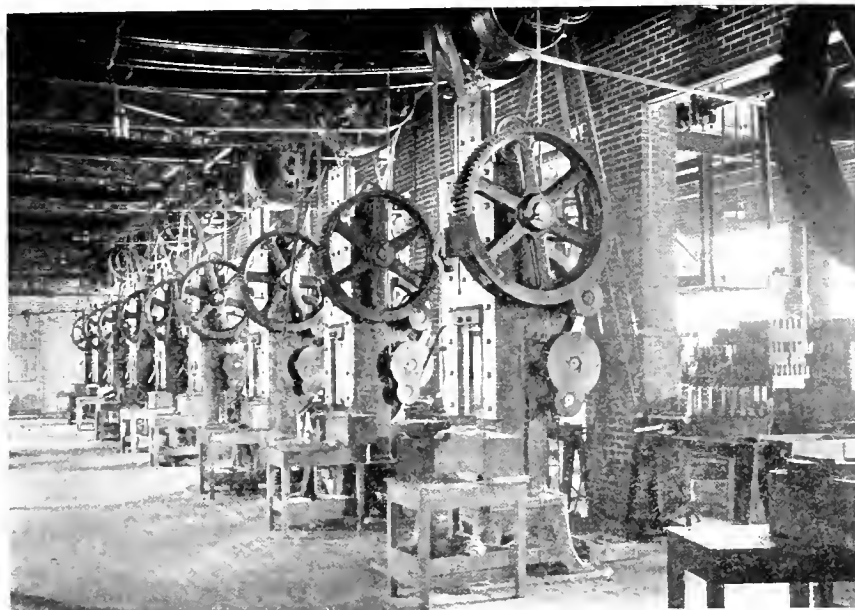

BATTERY OF RACK AND PINION PRESSES FOR FINAL DRAWING OPERATIONS.

faces up the head, after which the two chamfering tools form the rim of the head. A reamer on the turret then finishes the primer pocket preparatory to threading, through the medium of a collapsible tap, also on the turret. The threads are fourteen to the inch. The open end or mouth of case is next trimmed to length with a special fixture fitted to the lathe. The trimming operation reduces the length of case to 11.60 ins., which is the final length. The straight part of the mouth is then bored out to a diameter of 3.285 ins., which is the finished size.

Inspection and Stamping

A number of operations now follow. The first consists of hand tapping the primer pocket threads with a sizing tap. This is done to insure a high degree of accuracy at this important point, as the primer must be a good fit. The cases are then carefully inspected and afterwards stamped with the date, Government and manufacturer's marks, etc. The final or Government inspection next takes place. One case out of a series of one thousand is sent to Quebec for the firing test, while the balance are stored until the result is known. The cases are then

the production in each case is 250 per hour.

12th Operation—Machining Head and Mouth

All operations involving the use of presses have now been completed, but the case is not yet finished. The head and mouth have to be machined, a number of Bullard turret lathes being used for this, the twelfth, operation. The various steps in the latter are performed in the following order:—Rough-bore primer pocket, form recess in primer pocket, face and chamfer head, finish ream primer pocket, tap primer pocket, and finally trim open end of case.

Rough Boring Primer Pocket

The rough boring of the primer pocket is done by a specially designed drill having three diameters. The drill is fixed in the turret, the feed being controlled by a suitable stop. The recessing tool is also in the turret and has a special feed device to form the recess at the bottom of the primer pocket. The

facing and chamfering tools, or forming tools, are on a fixture at the side on the cross slide. The first of these tools

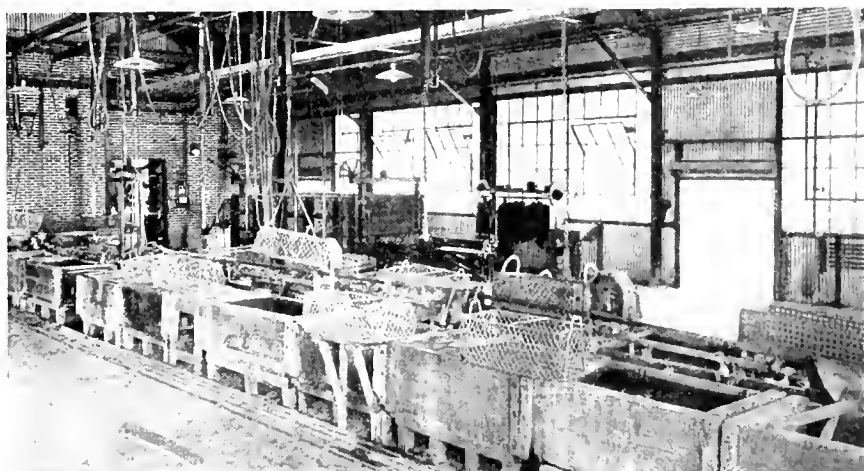

PICKLING AND WASHING TANKS IN FOREGROUND, AND TYPICAL ANNEALING FURNACE IN BACKGROUND. NOTE AIR HOISTS OVERHEAD FOR HANDLING PICKLING CRATES.

packed and shipped. A conveyor system for handling cases and shell boxes is installed in the storage and shipping room, same having been supplied by the Canadian Mathews Gravity Carrier Co., Toronto.

Testing

Brief mention has only as yet been made of the inspection feature which is of the greatest importance. After each annealing operation, a case is selected at random and taken to the testing room where seleroscope tests are made to determine the hardness of the metal. By this method possible errors are detected and corrected. Periodically, a case is cut in half, and readings taken on the seleroscope at various points across the section. The seleroscope tests are necessary in order that the case when completed may fully conform to specifications. This firm also employ a microscope for examining test cases to ascertain the quality of the metal; this is an

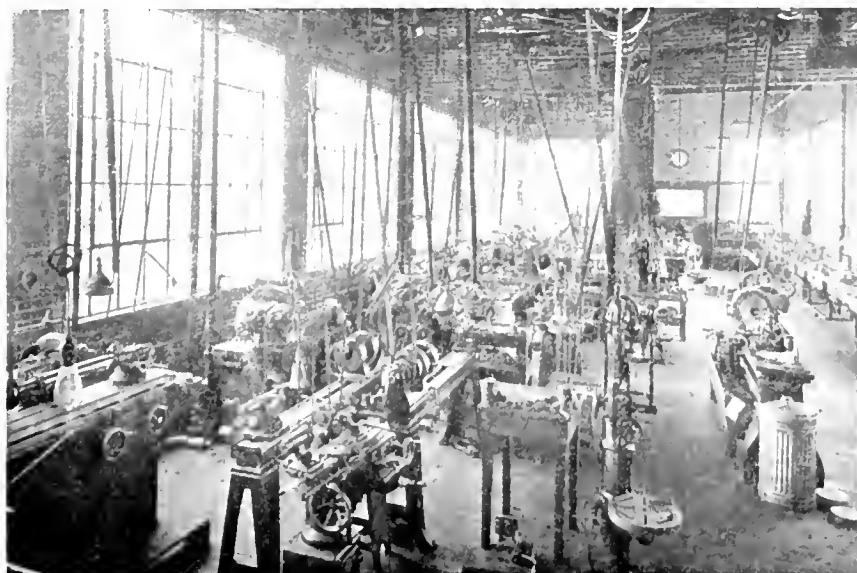

TOOL ROOM, WHICH INCLUDES PUNCH AND DIE MAKING DEPARTMENT.

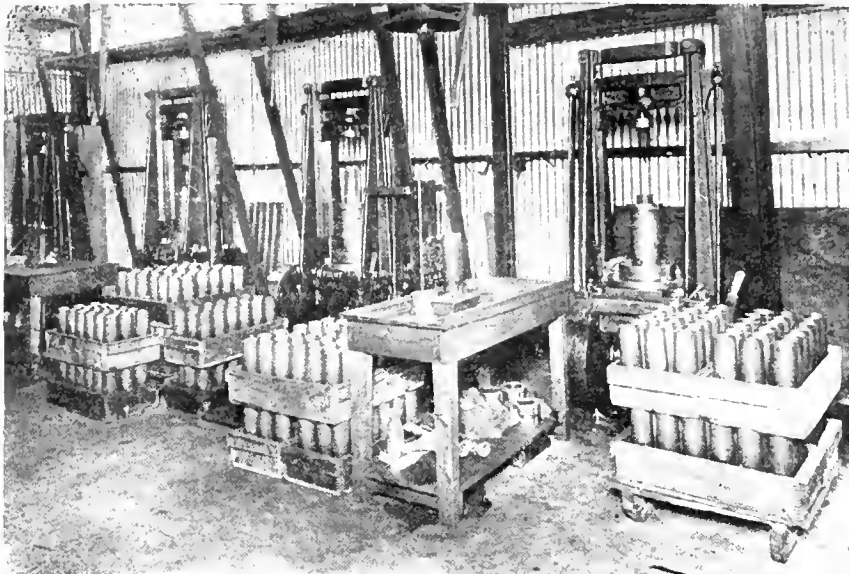

PRESSES THAT PERFORM THE TWO TAPERING OPERATIONS. FLASH ANNEALING IS DONE IN SAME DEPARTMENT.

additional safeguard against rejections. The scleroscope readings at the head range from 48 to 58, and at the mouth the average is around 40. The testing room has charge of the furnace pyrometers which are regularly compared with

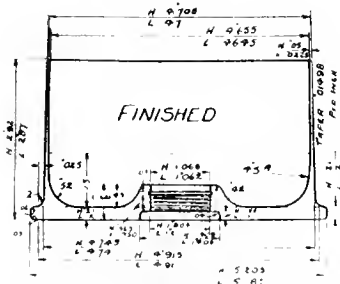

SKETCH OF BRASS CARTRIDGE CASE FOR 4.5 INS. SHELL.

a master pyrometer. During manufacture the cases are frequently gauged, the allowable limit being very fine for the majority of the dimensions. The final inspection is elaborate and involves the

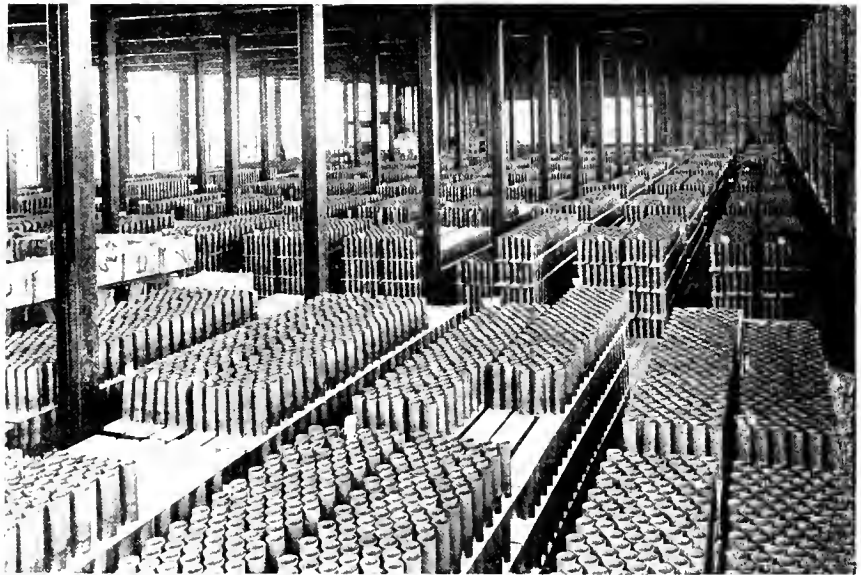

STORAGE ROOM SHOWING CASES IN BOND, AWAITING RESULT OF FIRING TESTS BEFORE SHIPMENT.



MACHINING HEADS OF CARTRIDGE CASES ON "BULLARD" TURRET LATHE. THE CASE MOUTHS ARE TRIMMED ON THE SAME MACHINES

gauging of every conceivable dimension.

4.5 ins. Howitzer Cartridge Cases

The method of manufacturing 4.5 in. howitzer cartridge cases is practically the same as that for shrapnel and the 18-pdr. H. E. Although much shorter, there is only one drawing operation dispensed with. The first four operations, annealings, etc., are identical with the 18 pdr. cases. The punches and dies are of the same design, only larger, while the furnace temperatures and annealing period are the same for both types. For the 4.5 in. case, the fifth operation is the second indent, followed by annealing for 44 minutes in a temperature of 1,150 to 1,160 degs. Fah. The third re-draw is the next or sixth operation, after which the cases are again annealed for 48 minutes at the same temperature as above.

The seventh operation is the fourth re-draw, which is followed by another annealing for 48 minutes at 1,150 to 1,160 degs. Fah. The fifth re-draw is now accomplished, on the conclusion of

which the cases are trimmed. The ninth operation, that of heading, is performed in manner similar to that of the 18-pdr. cases. The tapering operation then follows—there being only one taper in the 4.5 in. case, after which the head is machined and the mouth trimmed like the 18-pdr. cases. The primer pocket is afterwards hand tapped, inspection and stamping, etc., following same.

Conserving Scrap Metal

Not the least important feature at this plant is the care taken in collecting and utilizing the scrap material. A large melting furnace is located for the latter purpose in a separate building. The furnace is circular and has twelve pits. The scrap brass having previously been collected and bundled is melted in crucibles and cast into ingots. The brass ingots are then sold in the open market. Brass rods are also cast here for fuse body forgings. The trimmings from the

cases before being bundled are heated in a special furnace to remove oil, dirt, etc.

Tool Room Equipment

A very important factor in manufacturing cartridge cases is the employment of extremely accurate tools such as punches and dies. The company make all their own small tools, and for this purpose have equipped a well appointed tool room. The equipment installed comprises a number of grinding machines by various makers, including Pratt & Whitney, Brown & Sharpe, Le Blond, Ford-Smith and Landis, Blount, Davis and Oliver tool room lathes, drilling machines by the Perfect Machine Co., and Pollard & Shipman, Racine and Atkin-power haek saws, and a Cochrane & Bly universal milling machine.

The company have also recently equipped a new machine shop in connection with the die-making department, and have installed a general line of machine shop tools. Equipment for making fuse body forgings has recently been put in operation. The brass stock from which the fuse bodies are made is cast in bars, the latter being cut up in short lengths on a circular saw and afterwards heated in a furnace. They are then stamped in a press and trimmed. The operations are simple and production correspondingly large.

In conclusion, mention should be made of the highly efficient organization at the plant, the regularity and smoothness of operation making possible an unusually high rate of production. The degree of accuracy in manufacturing is apparently very high, rejections being very few comparatively. Success of the enterprise has been proven in other ways most substantially.

speeding up and facilitating the handling of different commodities required in the manufacture of munitions. Space will not permit the treatment of this subject broadly enough to cover but few of the ways in which conveyors are used by munition manufacturers, we will, therefore, attempt to treat the subject only as it applies to the handling of billets and forgings.

The handling of billets and forgings, especially the six inch size and larger, is one of the most important items of expense in connection with the shell forging plant, and requires careful consideration. The way this has been solved in many plants, by the use of gravity carriers and incline power conveyors, is more or less interesting. Some of these systems are very unique in their arrangement, and have afforded savings in many ways. By this means of conveying, the minimum amount of floor space is required, and in many cases the conveyors are hung from ceiling or posts, only using floor space at the loading point, from which they raise up on an incline and continue overhead. Very little power, as a rule, is required, as the major portion of the conveyor runs by gravity, and power sections are only used where elevation is necessary.

Power Operated Conveyors

The power section illustrated in Fig. 1, is an arrangement of two endless roller chains running over sprockets at both ends. These chains are connected together by short pieces of flat or angle steel, making a solid steel continu-

*Supt., Canadian Mathews Gravity Carrier Co., Toronto.

ous apron for shells to ride on. This is carried on four lengths of angle running under each chain, and these are riveted together with suitable angle braces and guards to prevent shells from rolling off. The down end of conveyor is arranged with adjustable bearing, permitting the chain to be tightened if

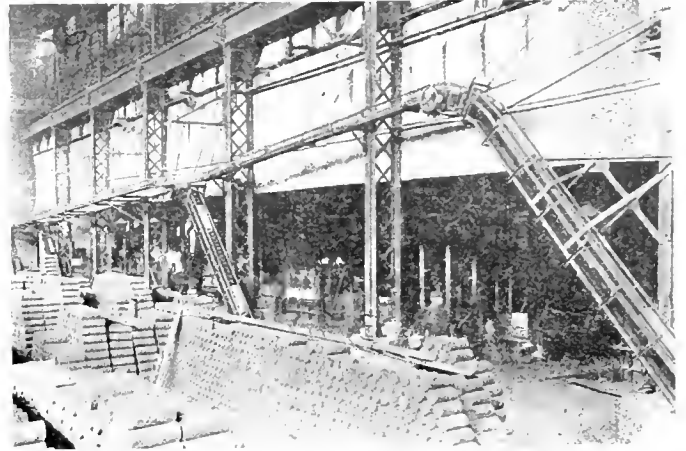

FIG. 1. POWER SECTION IN GRAVITY CONVEYOR

slack. The top end is connected with suitable bearings and shafts, and the drive is geared back from the motor with two gear reductions and one belt reduction, cut gears and rawhide pinions being used.

The sections of gravity conveyor also illustrated in Fig. 1, are securely connected at either end of power sections, and automatic delivery from either one to the other is made. Shells may be loaded on to the section of gravity carrier, on which they travel to elevating section, which picks them up and discharges them at top on to another run of carriers, on which they travel to desired destinations. Shells may be loaded directly on to elevator, in which case the lower end is depressed, so that the top of apron is level with floor, and shells are rolled directly on to the moving apron. Thus, by a combination of gravity and power conveyors, shells are handled any required distance at a reasonable expense, and with a minimum of power and space consumption.

Car to Stock Pile Transfer

For the unloading of cars of billets to stock piles close to siding, several sections of gravity carriers are used. These are made up with detachable couplings and are set up on portable adjustable stands, so that with the use of curve sections and adding or taking off sections, different points can be reached as required. In many cases, however, billets are unloaded and sent direct from cars to heating furnaces, where they are fed direct or stored. Fig. 2 shows a portion of a conveyor which handles billets direct from cars, and supplies five continuous furnaces. This is accomplished by means of hinging a short section of the main line, permitting the moving billets to drop through opening, upon chutes, at the end of which, additional carriers convey them to the furnaces. Billets are fed into furnaces direct of

CONVEYORS IN SHELL FORGING PLANTS

by M. J. Anderson*

FEW of us who are not directly associated with the manufacture of shells and forgings, realize the extensive part played by conveyors in



TWELVE CRUCIBLE CAPACITY FURNACE FOR MELTING BRASS SCRAP FROM CARTRIDGE CASES.

the carrier or from stock piles near by. When billets have reached the required heat, they are pulled out with tongs on short trolleys and are set in press and forged. They are next taken out of the forging presses and stamped, then rolled on to apron of incline elevator near by, and conveyed to cooling piles and annealing furnaces. The heat of the shells is in this way taken from the forging room, thereby increasing the efficiency of the men and adding to their productiveness.

Short runs of gravity carrier on portable supports are used from storage piles to annealing furnaces, and from annealing furnaces back to storage piles. It is also often found convenient to use these sections of carrier to connect stock piles with inspection benches. In close proximity to the inspection benches, one or two incline elevators are placed for the purpose of loading cars of finished and inspected forgings. These receive their final stamp on a block in front of conveyor which picks them up when finished, elevates them to the required height, and conveys by gravity to the cars. Fig. 3 shows conveyors loading cars of forgings, and illustrates the possible saving in space and time required for hauling.

Transporting Boxes of Munitions

In many cases, the munition plant has in addition to the forge shop, a finishing shop where all or part of the forgings are machined and boxed for shipment to powder plants for filling. In such cases, additional conveyors are used for conveying forgings from forge shop to machine shop, and between the different operations, including filled boxes to cars. A conveyor similar to the one illustrated in Fig. 1 is used to convey the forgings to the machine departments where a continuous line of ball bearing rollers, set on level, handles the shell

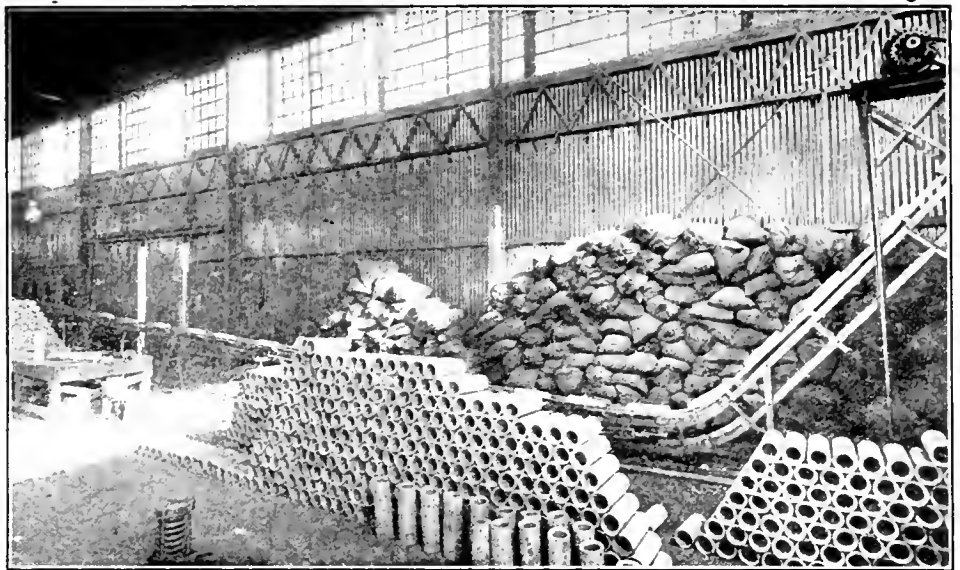

FIG. 3—SHELL FORGINGS BEING CONVEYED FOR LOADING ON CARS.

from one operation to another. Over these light running rollers they are easily pushed from one operation to the next, saving the labor of re-handling between machines. In some cases, these level lines of conveyor run completely around the different operations, connecting every machine, and continue on to inspection and shipping departments.

Empty boxes are conveyed by gravity from box storage to shipping room, where they are packed for shipment, often without being taken off the conveyor. Figs. 4 and 5 illustrate a system of handling boxes of filled shells to cars. These boxes are first elevated to required height by an incline elevator slightly different from those used for handling the billets and forgings. This type is made with a sheet steel apron for the box to slide on, and the chains are con-

nected with a pusher bar that engages box and pushes it up on slide. These also receive and discharge automatically in connection with the gravity carriers.

A different type of gravity carrier is also used to handle boxes. Because of the thickness and irregularity of band around these, a wheel type of carrier has been designed to meet this requirement. This consists of two rows of ball bearing wheels set on frame of steel bars, spaced at widths to suit the box to be handled. This construction allows the boxes to ride on the smooth surfaces, leaving the bands outside the rows of wheels.

In the various other branches of munition manufacture, such as cartridge case, fuse, powder plant and shell loading work, different ingenious designs and systems of conveyors are in use. We will not take the space to describe them further than to state that in all cases they have greatly increased the manufacturing capacity of these plants by speeding up and regulating the flow of products in system and order, with the minimum use of space. Because of the lesser labor required when these conveyors are used, they are releasing men who can be used on active service or other useful production at home. Due to the high price and shortage of labor, this type of conveyor has come into universal use and has solved the problem, not only for munitions work, but nearly all other branches of industry having large quantities of commodities to handle, and has opened a way to increase production.



NO MORE ROSS RIFLES

PART of the additional information, blue prints, and specifications necessary before the manufacture of the new Enfield rifle for the Government could be commenced at the Ross rifle factories has been received. The material required is not yet complete, but it is hoped that in a short time the Government will be in a position to order the production of a new service rifle.

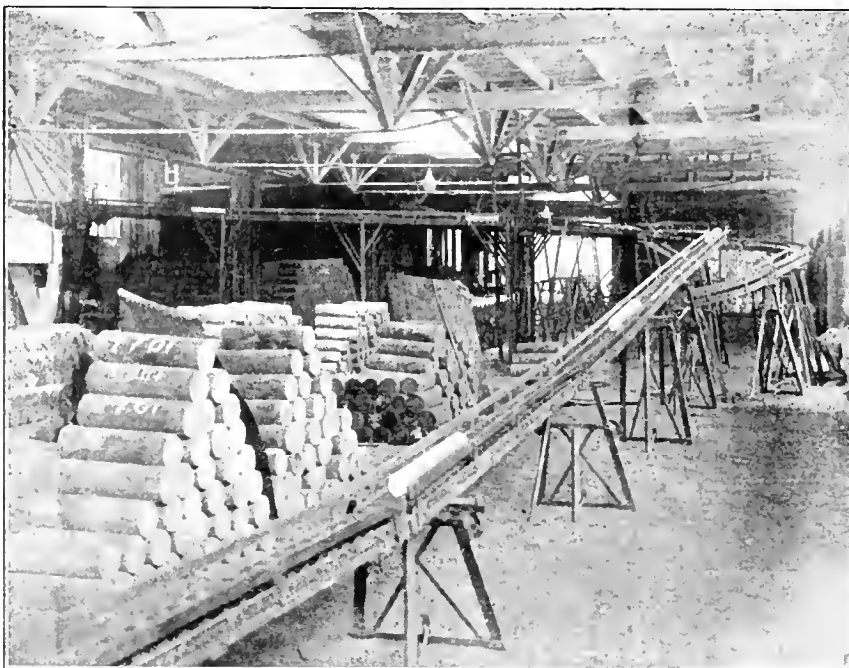

FIG. 2 PORTION OF CONVEYOR TRANSFERRING BILLETS DIRECT FROM CARS TO BATTERY OF CONTINUOUS FURNACES.

No Ross rifles have been ordered since February of last year, and no more will be ordered. None of the rifles being delivered under previous orders would be accepted now if the Government could avoid it. It is now stated that the Government endeavored to change delivery to Enfields of the undelivered portions of the orders already given. The terms on which the Ross Rifle Co. was prepared to meet the authorities, however, it is understood, meant that Enfield rifles could not be secured in any case except at far greater cost, and that there was practically no assurance that at any price they could be secured at all.



NEW BRITISH POLICY SOUND FOR CANADA

OUR Minister of Finance, Sir Thomas White, characterizes the speech of Lloyd George on Britain's new policy, as a wonderful epoch-marking utterance, one of the greatest, if not the greatest, in parliamentary history. "There can be no doubt," says Sir Thomas, "that the principles laid down by the British Premier are thoroughly sound and essential, having regard to the situation with which Great Britain is confronted at the present time. Two conditions have been chiefly responsible for the drastic action proposed. The first is the shortage of ocean tonnage and the second is the state of sterling exchange.

"From the latter, which is a financial standpoint, it is the proper policy

stuffs which she needs from these countries. She cannot pay for these imports, which have become so greatly increased over the normal, by her exports. The balance must be paid for in gold, or from the proceeds of loans made on this side of the Atlantic."

The Minister says further that the general lines of the policy laid down by the British Prime Minister were as sound for Canada to-day as for Great Britain. There is great need for increased production, especially in the agricultural sphere; there is also great need for the abolition of waste and the rigid limitation of "luxurious expenditure."

"The need for national saving is," he said, "imperative. Great Britain must have money here for her purchases of foodstuffs and munitions in Canada. Every citizen should save his money and have it available for our Dominion war loans. We can get orders from Great Britain for all the munitions and other supplies we can produce in Canada, providing we can lend Great Britain the money to pay the purchase price to the Canadian producers. This can be done only by national saving. It is a time for self-sacrifice and a time for self-denial."



TREATING HIGH-SPEED STEEL*

By A. E. Bellis and T. W. Hardy

THE problem of heat treating high-speed steel becomes more and more important as the design of cutters becomes more and more complicated in in-

hand, or scientifically executed on the other, the tool fails after a few operations, or its efficiency is greatly increased. The practical operation of giving these complicated tools the right temperature necessary to bring out the best cutting qualities, and at the same time bring the tool out "clean," is a difficult one and calls for no small amount of skill.

In order to be on the safe side the average tool hardener uses a temperature much too low to give the best results with the high-speed steel he uses. In the case of cutters, which are finished to a given diameter before hardening, it is impossible to grind the tool after hardening, so that it is essential that the surface be protected from oxidizing or decarbonizing. It is the aim of this paper to describe some experiments on hardening high-speed steel, in which metallographic means were used to determine the correct hardening temperatures.

The analyses for carbon, tungsten, chromium and vanadium of each steel used in the hardening experiments are given in the accompanying table. Six

Analyses of High-Speed Steels Used in Hardening Tests.

Steel	Carbon %	Tungsten %	Chromium %	Vanadium %
A	0.58	17.4	3.11	1.14
B	0.60	13.3	3.32	2.58
C	0.53	13.0	4.69	2.45
D	0.75	17.7	3.26	0.85
E	0.60	16.5	3.55	0.70

specimens from the same bar of each kind of steel were hardened from different temperatures, and photomicrographs made. Six samples were taken from the same bar in the annealed condition regularly furnished the tool maker. Photographs were made of the longitudinal section, care being taken to grind off the outer surface. The specimens, 1/4 in. were first pre-heated at 1600 deg. Fahr., and then quickly placed in the high speed furnace already heated to the desired temperature, left at this temperature for 1 min. and quenched in oil. The temperature was controlled by a standard pyrometer, consisting of a rare-metal couple and potentiometer. An optical pyrometer of the Holborn-type gave excellent checks with the standard pyrometer, and proved more convenient and durable. A precision of 10 deg. Fahr. was attained throughout. The polished specimens were etched for 15 min. in 1 per cent. alcoholic solution of nitric acid, and photographed under a magnification of 1000 diameters.

In general, the steels that show some excess carbide even at the maximum hardening heat are the most efficient. These, as a rule, are the steels with high tungsten content; they harden from a higher temperature and over a wider range than the lower-tungsten steels. For this reason they do not require as careful treatment and are, therefore, more popular than the lower-tungsten steels. The steels with lower tungsten and higher vanadium give better results when hardened at the lower temperatures than do the higher-tungsten steels when these are hardened at the same

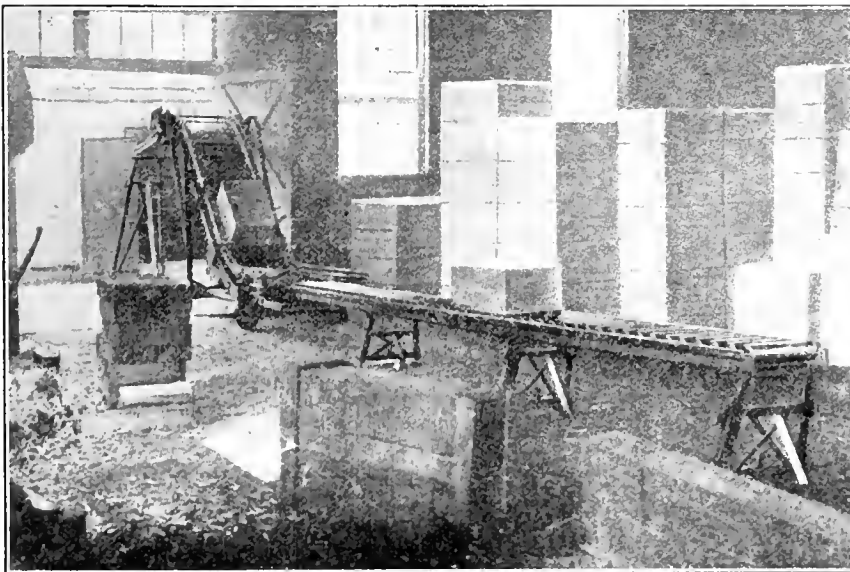

FIG. 4—CONVEYING BOXES OF FILLED SHELLS TO CARS

of Great Britain to import only those essential things which she must have and cannot produce at home in sufficient quantity for herself and her Allies, whom she is helping to finance. These things will be found to be principally foodstuffs and munitions. She must find money abroad to pay for such as these as she purchases abroad. That is to say, for example, she must find money in Canada and in the United States to pay for the munitions, grain and other food-

creasing the efficiency of mechanical operations. Hundreds of dollars are spent in the design and manufacture of milling cutters of special form for rapid production of duplicate or interchangeable parts, and then, as the heat treatment is faulty on the one

*From a paper presented at the February meeting of the American Institute of Mining Engineers in New York. Mr. Hardy is metallurgist, Nova Scotia Steel & Coal Co., New Glasgow, N.S.

low temperatures, but the comparison is not so advantageous to the lower-tungsten steels when the steel with high-

for all tools is very poor practice, for, as shown by the photomicrographs, the best structure may be obtained with one

or D, but tools made of other steels would not stand up if hardened at this temperature. More extreme examples could be cited, but the samples chosen are typical of the most widely used brands of such steel.

The average hardener rarely obtains the best result from his steel. The reason for this is, especially in the cases of tools that cannot be ground after hardening, that oxidation becomes a serious problem at higher temperatures. The use of a barium chloride bath to eliminate this difficulty has the disadvantage that the surface of the tool becomes decarbonized. A method that has proven satisfactory is to place the tools after preheating in the reducing atmosphere of a carbon resistance electric furnace already heated to the required temperature. The very short time necessary to get the tool to the temperature of the furnace eliminates deleterious surface effects. Pack hardening often gives good results but, owing to the great affinity of iron for carbon at high temperatures, care must be taken to reduce this carbonizing action to a minimum. This may be done by selecting a packing material of little or no carbonizing power, and by cutting down the time during which the metal is in contact with the packing material.

The increased efficiency and cutting power of tools that have received the proper heat treatment is out of all proportion to the time given to the study of the particular steel involved, and to the care exercised.

OFFICIAL PRICE OF ALUMINIUM

THE selling price of aluminium ingots of ordinary commercial purity of 98-99 per cent. has been fixed by the British Ministry of Munitions at \$1.125 per ton, carriage paid to consumers' works. The maximum selling price of re-melted aluminium scrap and swarf ingots of 98-99 per cent. purity has been fixed at \$1.050 per ton, carriage paid to consumers' works. The maximum price must not be exceeded, but a lower one may be fixed by agreement between the seller and the buyer, based upon the metallic aluminium content. These prices took effect as from 1st January, and permits under Regulation 30A of the Defence of the Realm Regulations will be granted only for such dealings in the above-mentioned materials as are in accordance with the above prices. The above prices are subject to alteration, at any time, as may be directed by the British Minister of Munitions.

Damping Their Spirits.—A little boy was reading in his Scottish history an account of the Battle of Bannockburn. He read as follows:

"And when the English saw the new army on the hill behind, their spirits became damp."

The teacher asked the boy what was meant by "damping their spirits."

The boy, not comprehending the meaning, simply answered:

"Pittin' water in their whisky."

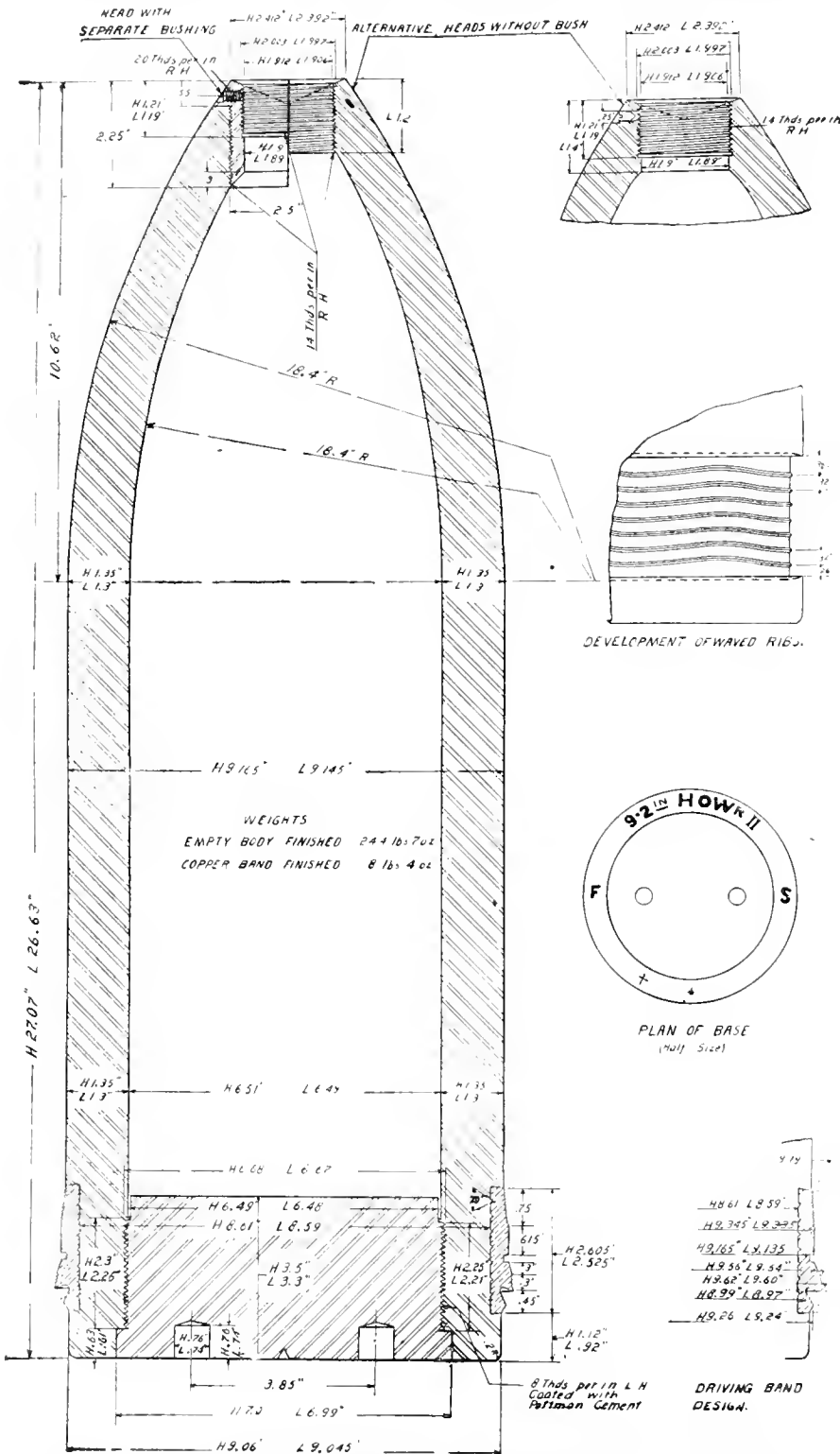

TYPICAL 9.2 INCH HOWITZER SHELL. THE 8-INCH PROJECTILE EMBODIES THE LIKE GENERAL FEATURES.

er tungsten is given the proper hardening heat.

Hardening Temperature Control

The importance of carefully-controlling the hardening temperature, and of varying it for the particular steel used, cannot be over emphasized. The custom of using one "high-speed temperature"

steel at a temperature which will "burn" another, or not harden a third. Thus 2300 deg. Fah. or over is necessary to give A or E a good structure, but this temperature gives a coarse grain in the other steels or "burns" them. Again, a temperature as low as 2150 degs. Fah. can satisfactorily harden B

8 ins. H. E. Shell Production by Public Utility Corporation

Staff Article

As no two men think alike, and local conditions are more or less varied, it is quite obvious that methods of manufacture of a given product will differ somewhat. In addition, the nature of pre-war equipment installed, and the specific service to which it had then been applied, have not been without effect in creating considerable divergence in the routine and practice of shell-making, although equal degree achievement be the ultimate outcome.

WHILE the finished product in every instance must conform to rigid specifications, the methods of achievement are more or less questions that each firm have to decide for themselves; and in this connection it might be said that the modernly equipped shop does not always necessarily show the best results.

Contributories to Success

The plant from which the following data were obtained has met with notable success in the production of 8-inch howitzer shell, largely because of the elimination of unnecessary machining, handling

ating the unproductive factor. It is not here intended to dwell on the details of manufacture at this plant, in extenso, the purpose being rather to give to our readers a raey outline description of some of the more interesting methods employed to secure economic and rapid production.

Owing to the inability to store the rough forgings in a closed or heated building, the accumulation of snow-frozen and otherwise, is unavoidable; therefore, before delivery to the machine operators, it is necessary to remove at least the greater part of the ice and moisture adhering to each individual forging. The method adopted, and one that has proved

The method adopted for this operation differs from that employed in some other plants, inasmuch as the shell is held in a horizontal position while the work is being performed. A special heavy turret has been placed upon the saddle of a Petrie lathe, the housings being of ample weight to rigidly support the bar and maintain it in proper alignment. The turret is locked in a permanent position when drilling, but can be swung outwards to remove and replace the shells. The bar upon which the shells are placed is of the expanding type, operated by means of a wrench at the opposite end. An effective method of feeding has been devised

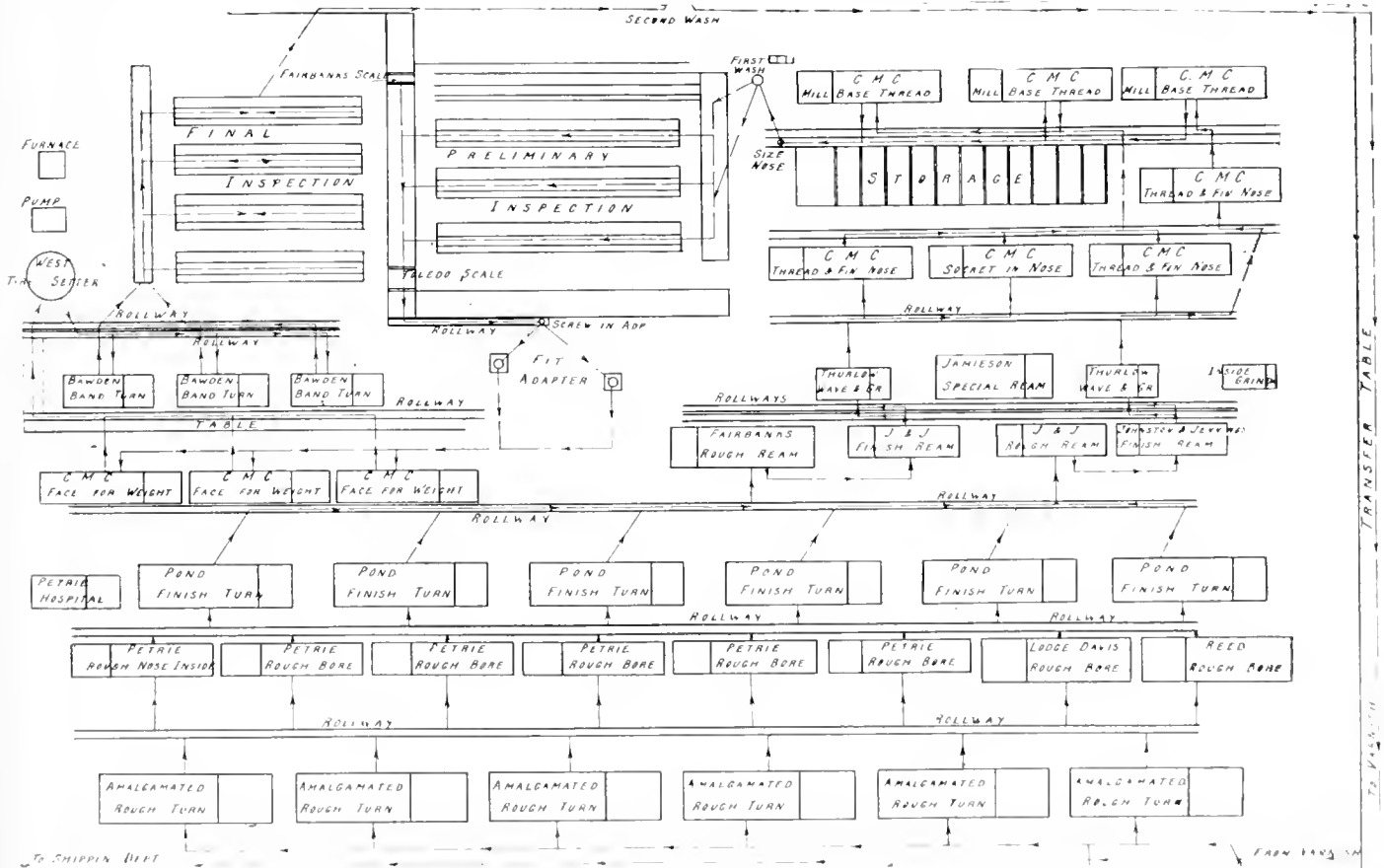

FIG. 1. MACHINE TOOL LAYOUT FOR 8 INS. H. E. SHELL FINISHING.

and transportation operations. The management decided on a tool layout that would avoid any "backing up" on the progressive movement of the shells through the shop. To insure greater accuracy in machining, the various settings of the work have been reduced to a minimum, a preference being evident to involve fixtures and attachments whereby two or more operations could be accomplished at the one time, thus elimin-

highly satisfactory, is to roll the forgings along a slightly inclined runway, within which are heated steam coils, the heat from these being sufficient to accomplish the desired purpose while the shells are moving slowly along the supporting rails.

Drilling the Nose

The forgings are first tested for rough length and general concentricity, after which they are drilled through the nose,

by fitting an air-brake cylinder to the bed, between the shears and back of the saddle. The advantage of this device is a steady but elastic feed, and central thrust.

thus eliminating any irregularity in the movement of the saddle. The feed control is obtained by means of a motor-man's brake valve. Care has to be exercised, when the drill is breaking through, to release the air and finish with the hand feed.

Twist Operation Handlings

The handling of the shells to and from the various machines is a very important factor in shell production. The facilities for this purpose must not only be efficient, but should be so designed as to eliminate the chance of a shell slipping out should the tongs or lifting clamp rest upon any object. The tongs shown in Fig. 3 can be locked upon the shell when in use, and quickly released when required. The section A which carries the eye bolt B is about six inches wide, while the opposite side is about three inches wide, and is secured to A by means of the bolt D. The elamping screw E can be made of any desired length, as it is often desirable to use it to place the shell at some distance at the back of the machine.

tie in this plant is to commence at the very beginning to work very close to the high and low limits of specified dimensions. Experience has shown the efficiency of this system, as it has been found that it is as easy to start on an accuracy basis, and continue to do so, as it is to leave much to chance at the beginning and subsequently find that certain operations are actually being performed a second time. Fig. 4 shows a dimension sheet for primary operations; a sectional view of the finished shell being shown, together with an outline of the rough forging. Determining a point from which all subsequent measurements

the evolution from forging to finished shell commenced. It was calculated that his position was the most desirable, as it

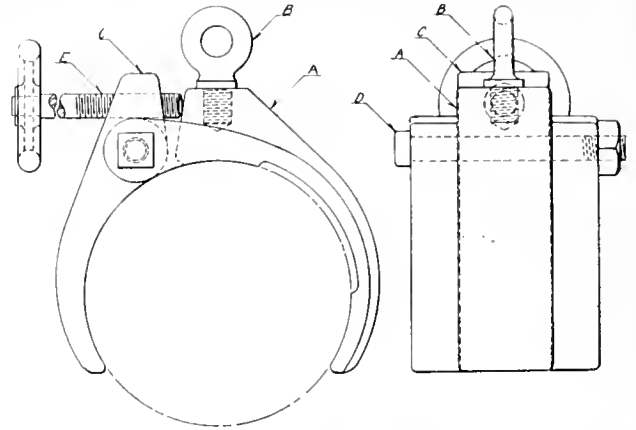

FIG. 3. SHELL LIFTING TONGS.

would give the greatest degree of accuracy, owing to the fact that the forging punch, at this point, would retain its shape for a longer period than one closer to the nose. When the forgings are first received, a disc gauge of 3 3-16 inch diameter is put in the shell, and if the depth from the disc to the outer surface of the nose is not below 3 3/8 inches, it is an indication that sufficient stock is available for internal and external machining.

Cutting to Length and Roughing

Three Jamieson lathes are used for cutting to length, both ends being removed at the same time. These lathes are fitted with expanding arbors, having a nose similar to that shown in Fig. 4, with a diameter of 3 3-16 inches. The cutting tools are set in a permanent position, that for the open end being 19 5-16 inches from the nose of the arbor, while that for the small end is set 4 inches from the same base. It is very obvious, therefore, that succeeding machining operations must be accurately performed, as over-all length after cutting-off is within 1-16 inch of the finished dimensions. One Bridgeford and six Amalgamated lathes are working on the rough turn operation.

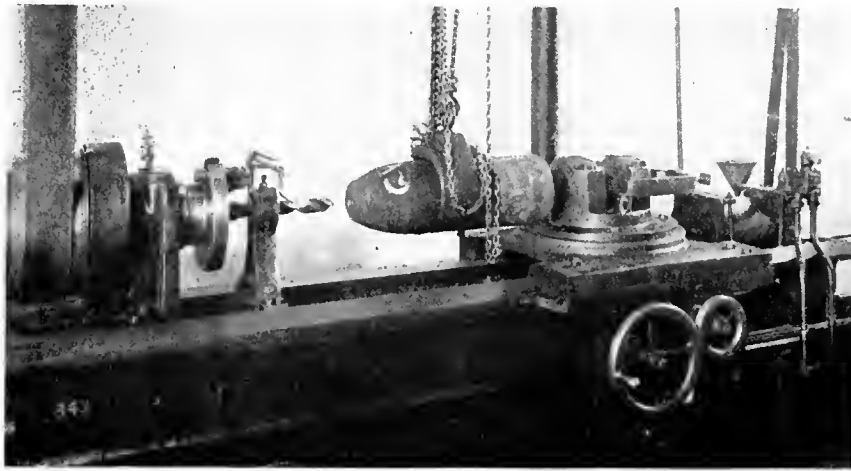

FIG. 2. DRILLING SHELL NOSE ON "PETRIE" LATHE.

Accuracy in Primary Operation

Contrary to the general method followed in many shops of allowing wide limits on the preliminary operations the prac-

could be taken was the essential problem, and, after due consideration, a diameter of 3 3-16 inches on the inside rough profile was decided on as a base; from this

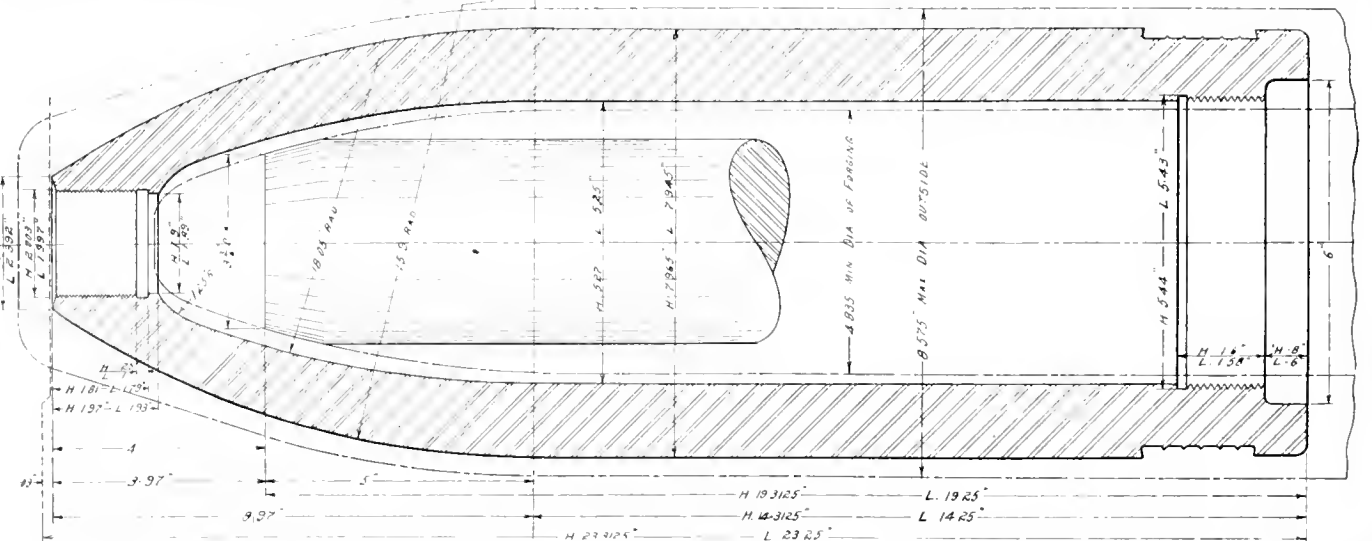

FIG. 4. DIMENSION SHEET FOR PRIMARY OPERATIONS, WITH SECTIONAL VIEW OF FINISHED SHELL, ALSO OUTLINE OF ROUGH FORGING.

Here again the gauging reverts back to the base before mentioned, but otherwise the machining is very similar to that in other shops.

Roughing the Bore

Rough boring, as accomplished in this plant, is somewhat of a departure from the general practice. Five Petrie, one Lodge-Davis and one Reed machines are used for this purpose, each being fitted with a special boring attachment as illustrated in Fig. 5. The operation of this device will be better understood by referring to Fig. 6. The chuck A, which is secured to the face-plate of the lathe, is of the pot type, the outer end being supported in the steady rest C. The boring bar, 4½ ins. in diameter, is clamped to the turret P by means of the cap E. The radius rod connection G is clamped to the rear end of the bar, the link stud being located at same distance from the centre of the turret as the cutting point of the radius tool, which is placed directly back of the notched forming cutter. The radius rods H, one above and below the bar, have a centre length of 18.05 inches, this being the radius of the inside profile. The centre of motion from which the radius rods oscillate is on the slide I, this slide being adjustable on the bracket J. The angle iron K that supports the ends of the push bolt L is secured to the saddle of the lathe. When the attachment is in the position shown, the centre of the bar D is in the same axial line as the lathe spindle, thus permitting the staggered notched cutter to rough out the extreme nose of profile, the depth being gauged by an adjustable bolt located in the front cap of the turret, and bearing against the base of the shell.

When the gauge bolt is in contact with the face of the shell, the feed (reverse) is engaged, and the saddle starts backwards, the radius bracket J remaining stationary, causing the outer end of the link to sweep through an arc having a radius of 18.05 inches. This motion is consequently transmitted to the opposite end of the bar and tool, thus forming the desired contour. When the nuts on the

will, therefore, have a parallel motion through the remainder of the shell bore. This method of roughing out the interior of the shell has many advantages, not the

Reaming the Bore

While the method generally employed is to revolve the work when finishing the bore, a reversal of this practice has been

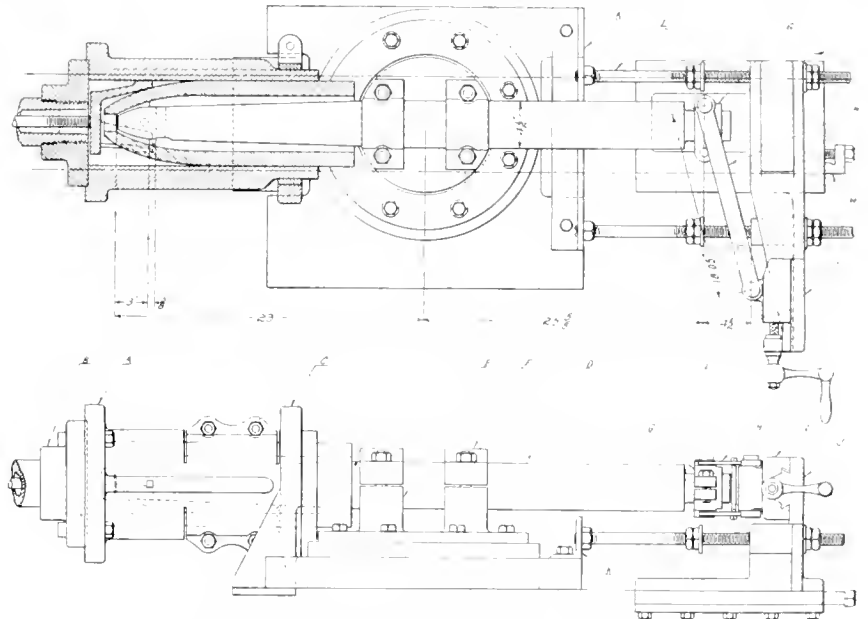

FIG. 6. ROUGH BORING ATTACHMENT ON "PETRIE" LATHE.

least of these being the great saving effected in the amount of tool steel required, which at the present time is a very important factor.

Finishing the Outside Diameter

For the finish turn operation, six Pond lathes are installed, each equipped with special profiling attachments. Cams were used for a time, but were afterwards replaced by radius links, this method proving more effective. As the shells have been cut off to within 1-16 inch of the finished dimensions, the closest degree of accuracy is required in setting the tools and tangential point of profile. Tools are set with a special gauge in order that no variation may arise in the starting of the cut. The profile attachment is permanently set for a maximum length shell, and, where a shell gauges short, a thin liner, corresponding to the amount lack-

adopted in this plant. For the machining of this portion of the shell one Fairbanks and three Johnson & Jennings lathes are installed, these usually working in pairs; that is, two on the rough ream and two on the finish. A fifth lathe is provided for the final finishing of those shells, the interior of which have not cleaned up on the pre-finish ream. The reamers on this lathe are those received direct from the tool room, and are made to the largest tolerance of bore diameter and profile. As the reamer on this machine becomes dull, it is transferred to the ordinary finishing lathes, the cutters still being well within the limits of tolerance. When the cutters wear to the point where the low limit is reached, they are transferred to the rough reaming operation. By using the reamers in this way it has been found that a great saving has been effected, both in time and material. The second or finish ream generally brings the bore to size, but when the marks from the rough boring are too pronounced, it is deemed advisable to smooth the surface by working to the high limit, necessitating a third reaming on the fifth machine. The reamers are of the solid, three-blade type, and excellent results are being obtained. An approximate amount of metal removed on the two operations would be from 1-64 to 1-32 inch. The neutral diameter of the finished bore is 5.26 inches, with a high and low tolerance of .010 inch.

As shown in Fig. 7, the shell is clamped in a heavy and rigid fixture secured to the saddle of the lathe. This fixture is machined out in its working position, thus assuring accurate alignment. The feed is obtained by means of large diameter, belt-driven pulleys. A gauge is secured to the front bearing of the headstock to indicate the depth of bore. This, however, is only a guide for saddle travel, the

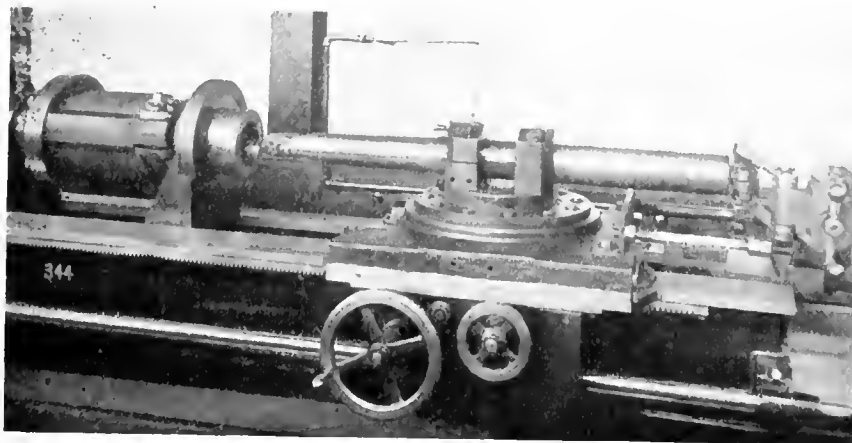

FIG. 5. ROUGH BORING ON "PETRIE" LATHE WITH ATTACHMENT AS DETAILED IN FIG. 6.

push rods come in contact with the radius rod bracket, the entire device will travel in unison with the saddle, and the tool

ing, is placed over the control rod, thus shifting the tangential point to the correct position.

actual depth being determined by a special gauge, shown resting close to the saddle of the lathe. This small but interesting device is largely responsible for the successful results achieved. Owing to the fact that the machining on the nose bore has not been accomplished at this stage, it is apparent that accurate gauging for depth of metal would involve considerable guesswork without a suitable gauge.

Gauge for Depth of Nose

A sketch of this gauge is shown in Fig. 8. The reamers are provided with a fit on the nose end, small enough in diameter to pass through the drilled hole. The gauging points, as shown by ring A, are taken at a diameter on the reamer, or inside profile, of 2 inches, and on the external nose of shell of 2.4 inches. These points never vary, they being $1\frac{1}{4}$ inches apart. As the extension on the reamers may vary in length, adjustment is necessary when setting the gauge, but when once set it remains constant until the reamer is replaced. When a new reamer is placed in the machine, the ring A, together with the gauge B, is placed on as shown, and, by means of the screw C, the gauging point E is set to enter the centre in the end of the reamer. It is then locked by means of the nut D. When reaming is in progress, the ring A is removed, and the gauge B placed on the nose of the shell, so that when the point E fits the centre of reamer, the depth is correct. The ring A is for the Mark III., and that at F is used on the Mark V.

Waving and undercutting is accomplished on two Thurlow machines. Two tools only are required to complete the groove, the waving tool cutting in the full depth without previous roughing. The sides are then undercut.

Threading the nose is performed much in the same way as in other plants, with the exception that the tools are secured to a fixed slide instead of the ordinary turret, the cross slide being located in the different positions by adjustable stop gauges. Four C. M. C. lathes are used on this operation, one of them being fitted for the socket hole in the alternative nose.

Base Finishing Operations

Machining the base and cutting the thread for the adapter is performed in an interesting and efficient manner. Fig.

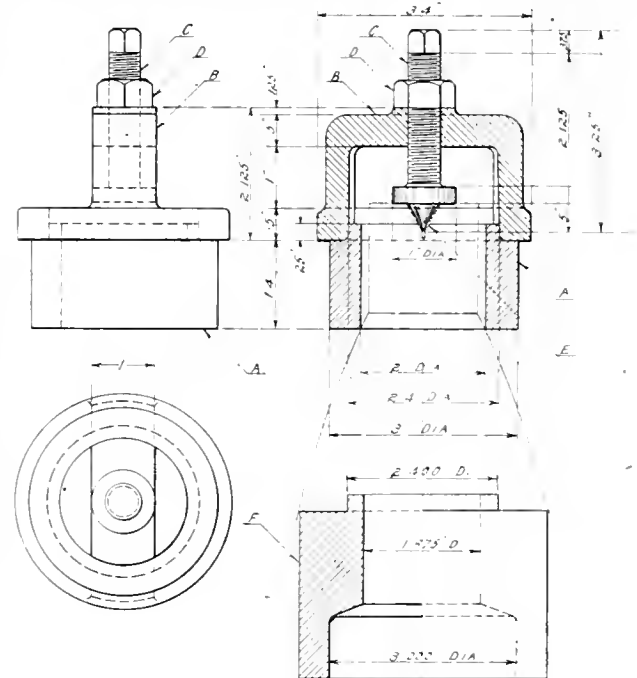

FIG. 8. GAUGE FOR DEPTH OF HOLE IN NOSE.

9 illustrates the fixture as used on several C. M. C. lathes. The set-up is similar to that for the nose, the boring tool and milling cutter being fixed in a parallel position on the cross slide, and being moved latterly to the working positions. Fig. 11 is a sketch of the hob milling attachment. The rest A is for holding the tools and cutter, while B is the driving pulley and C the cutter. The driving device E for hob milling is described in detail later. At G is seen the bracket with reducing gears, H being the extension to the back of the shifting lever to which the safety cord I is attached. The pulley J, round which the cord passes is bolted to the bracket secured to the end of the lathe. The upper end of the cord I is tied to the tilting lever K, which is pivoted to the hanger.

When the lathe is being used for cutting the counterbore, the stick K will be in the position indicated by the dotted line, but, when hobbing the thread with the

reducing gears in mesh, the stick will be in the position shown, thus preventing the operator from throwing on the driving belt while thread is being milled. The jib crane illustrated in this cut is typical of those used throughout the shop. The milling fixture is of home design, being constructed from existing parts about the plant, this practice being one of the features of the equipment generally.

Driving Device for Hob Milling

A sectional view of the driving device for hob milling the threads is shown in Fig. 12. Fitted to the nose of the lathe spindle is the adapter B, the outer end being threaded 16 to the inch. This piece is connected to the shell nose centering ring by the feed nut C, the latter being threaded right and left hand of similar pitch. The nose plug is screwed into position in the shell and then drawn back firmly in the ring chuck D. It will be noted that the thrust collar F on the operating shaft G bears against the shoulder of the piece D, so that the shell is free to advance when thread is being hobbled. The positive drive is effected by the clutch formed by tongue and groove between the pieces B and D.

When a thread is ready to be milled, the cutter is placed in position, the slow speed reducing gear engaged and the feed nut locked by means of a bar placed against the clamp bolts, and resting in a bracket secured to the shears of the lathe; this can be clearly seen in the illustration, Fig. 9. As the lathe spindle slowly revolves, the shell gradually advances at the rate of $\frac{1}{8}$ inch per revolution, this action resulting from the turning of the right and left hand threads, of 1-16 inch pitch, in the stationary nut C. About a revolution and a quarter is given for each shell. Before the next shell is placed in the chuck, the feed nut is turned back to its original position. A sketch of the reducing gears is shown in Fig. 13.

Sizing the Nose and Washing

Following this operation, the thread in the nose is finished to size, a new tap being used for the purpose. The method adopted for performing this work is simple yet very efficient. The tap is held in a pneumatic air drill which is supported by means of a cable directly above the floor chuck that holds the shell. The motor is counterbalanced so

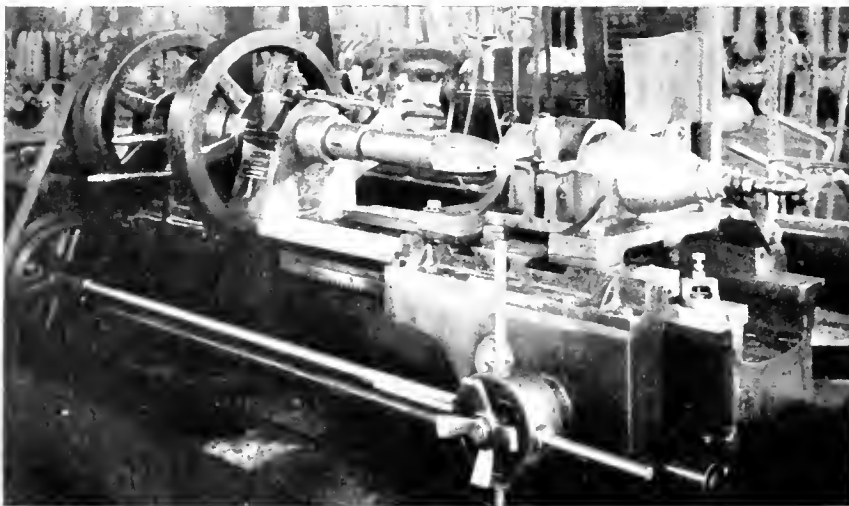

FIG. 7. FINISH REAMING ON "JOHNSTON & JENNINGS" LATHES.

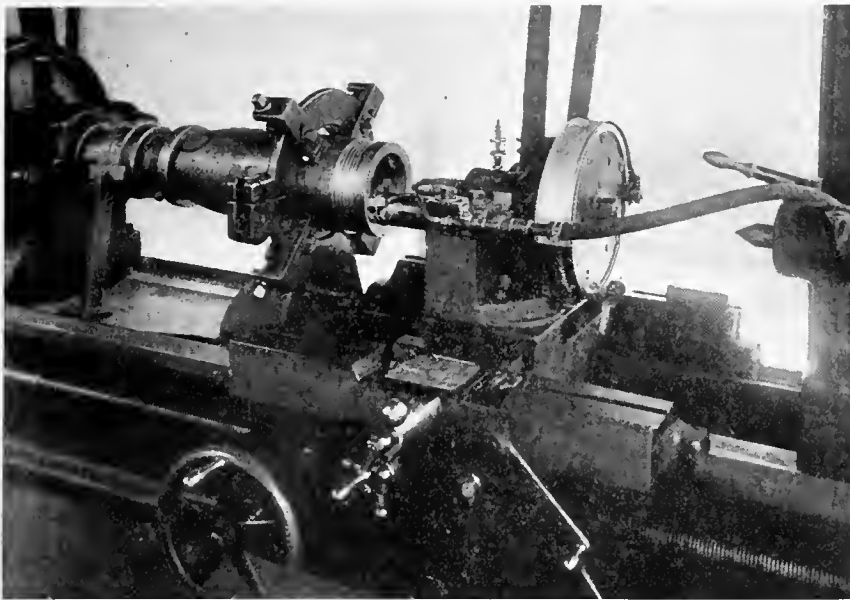

FIG. 9. FRONT VIEW OF BASE THREAD MILLING ATTACHMENT ON C.M.C. LATHE.

that very little effort is required to operate it.

Before being weighed, the interiors of the shells are thoroughly washed by means of benzine, this being applied in a manner that insures the liquid reaching all parts of the bore. The shell is placed base downwards in the centre of a small tank and over a vertical pipe that extends almost to the nose of the shell. This pipe is well perforated, and, when the pressure is turned on, the liquid is forced against the inner walls of the shell, removing all traces of grease and dirt.

Weighing and Marking

Inspection for weighing and marking, which follows the washing process, is done on a Toledo scale, and the practice in vogue is deserving of special mention. As the maximum amount of stock that can be removed is only 1-16 inch, this being the working limit during progressive operation, four finished adapters, having collars varying in thickness by 1-64 inch, are provided for checking purposes. The depth of base counter-bore is measured, and the adapter, whose shoulder corresponds to this mea-

surement is placed on the scale together with a copper band that has previously

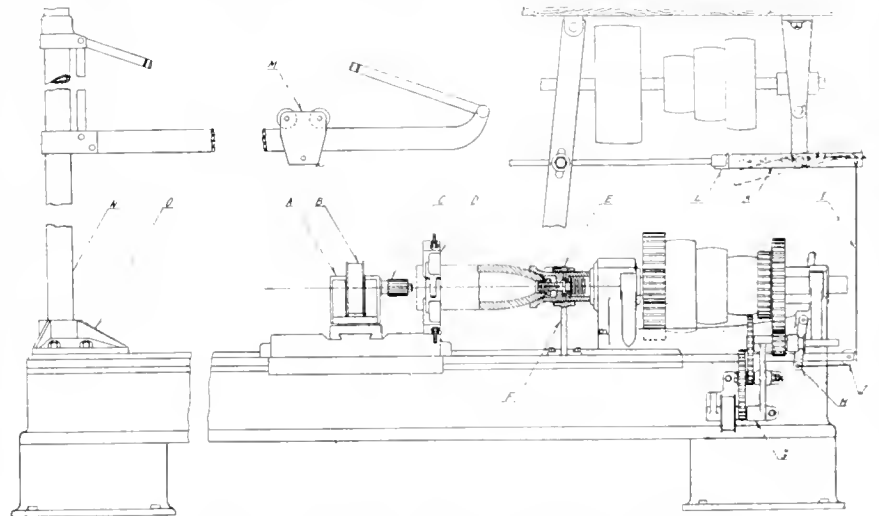

FIG. 11. BASE THREAD HOB-MILLING ARRANGEMENT.

been machined; the three pieces are weighed, and, from a carefully prepared table, the exact amount of metal to be removed from the base of the shell, in-

respective of the adapter used, is readily determined. When the weigher marks the shell for final facing, he does it with a double prick punch, which serves two purposes: the mark close to the base indicating the base facing, while the one higher up serves as a cheek on the operators. By this method any error can be immediately traced to the proper source.

Turning Copper Band

Succeeding operations are much similar to others of the same nature and need no special mention, but it might be well to note that the turning of the copper bands is being accomplished without the use of special features, this work being performed on an ordinary engine lathe with much success. The scaly surface is first removed by using a single-pointed tool, after which the band is shaped with a forming tool held in the tool post of the lathe, the groove and serrations put in, and, lastly, the outer diameter finished with a tool at the back of the saddle. This latter tool is set in a permanent position every morning by a tool setter, and seldom requires further attention during the day.

Final Washing and Varnishing

After marking and checking for weight, the shells are given a second washing, this being accomplished by spraying the interior with wood alcohol, following which they are taken to the varnishing department for interior finishing. This process is performed in a very efficient manner, the shells being partly filled with varnish and revolved by a mechanical device to insure a thorough coating of the entire surface. Several methods were tried out, but it was found that this process more nearly approached brushing than any other, brushing being the ideal way for best results. When the varnish has been poured out the shells are placed upon another revolving device, where the threads in the nose are cleaned out with a brush dipped in alcohol, the shell revolving in a direction that will wash the surplus varnish to the outer edge.

Owing to the poor quality of drying medium that is now embodied in the

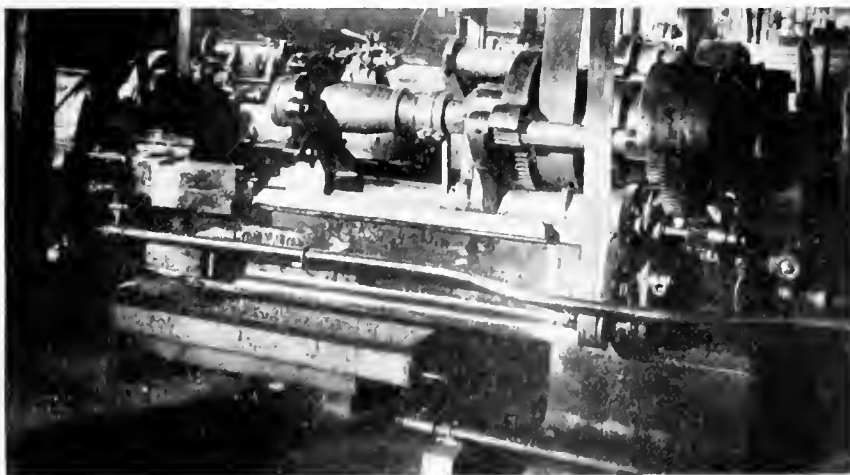

FIG. 10. REAR VIEW OF BASE THREAD MILLING ATTACHMENT ON C.M.C. LATHE.

varnish used, much difficulty has been experienced in obtaining a good permanent coating on the surface of the

moved to the very front of the saddle, and the special fixture as shown in Fig. 14 is brought into a central position.

The Grand Trunk shops also employ women—comparatively few, so far, but the superintendent is adding to the number. By and by women will play an important economic part in the supply of transportation service in Canada.

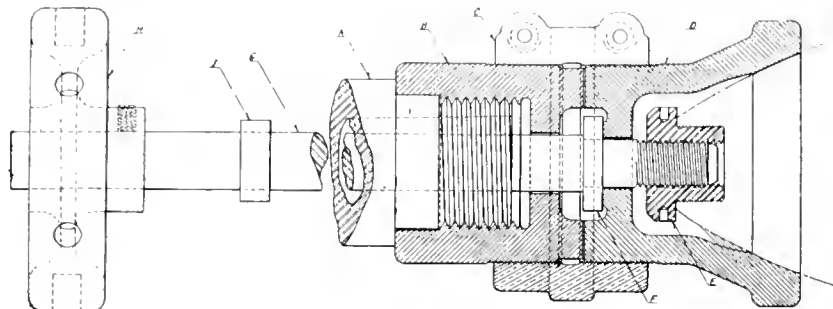

FIG. 12. ASSEMBLY OF DRIVING DEVICE FOR HOB-MILLING BASE.

shells, a tendency to flake before final setting, being apparent. Just recently, the superintendent tried out an idea, its simplicity being second only to its efficiency. The shells, after varnishing, are placed upon a truck with a small piece of tin placed in the nose and bent at an angle to deflect the air that is blown over the surface from a small fan located upon a shelf at a height of about 3 or 4 feet above the shells. By this method the drying process is completed in from twenty minutes to an hour.

Machining the Adapters

Brief mention may be made of the operations on the adapters. These consist of drilling the pin holes, rough diameter and face, rough collar, finish turn and thread, and size collar. With the exception of the finishing, the operations vary but little from other plants, and it is only the latter on which we need dwell. In common with many of the operations on the shell body, the practice of threading the adapter at the same setting as the finish turn results in greater accuracy, and avoids the possibility of eccentricity that is often ap-

This device carries a collapsible die, and is fitted with a counter-balance to maintain its alignment and assist in moving it to and from its working position.

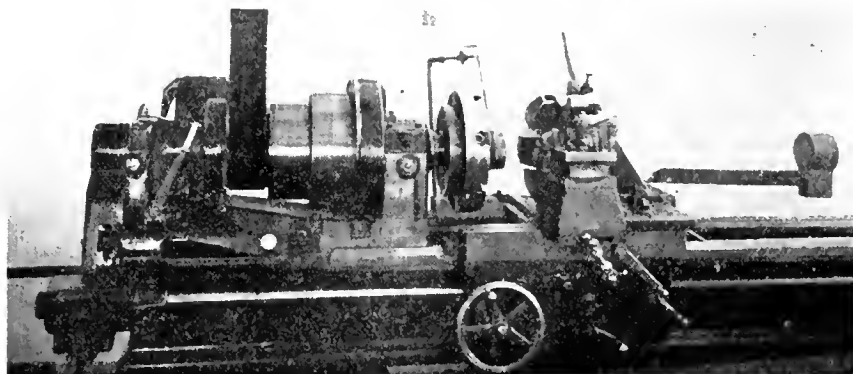

FIG. 14. SPECIAL ATTACHMENT FOR FINISHING ADAPTERS.

WOMEN EMPLOYEES IN RAILROAD SHOPS

THE C.P.R. is adding to the number of women workers at the Angus Shops, as these are required in a variety of employments. The workers have been organized by Mrs. Bell the wife of J. Bell, the superintendent of Windsor Street Station. They were carefully selected, and brought under shop regulations. They have done splendidly, and hold out the promise that women may undertake a variety of employment supposed to be the prerogative of men. The shops are turning out munitions, of course; but they are also building and repairing rolling stock, and in connection with light duties so required the women are making a good showing. The matter has now got beyond the experimental stage. Women

Known to Toronto as the daughter of the late William Irving, and widow of Dr. Fenton, the new head of the Women's Section of the Imperial Munitions Board has done varied war work. Mrs. Fenton also has the benefit of the experience of a practical munition worker. For, nearly a year ago Mrs. Fenton was one of the first of Toronto's women to work in a local factory.

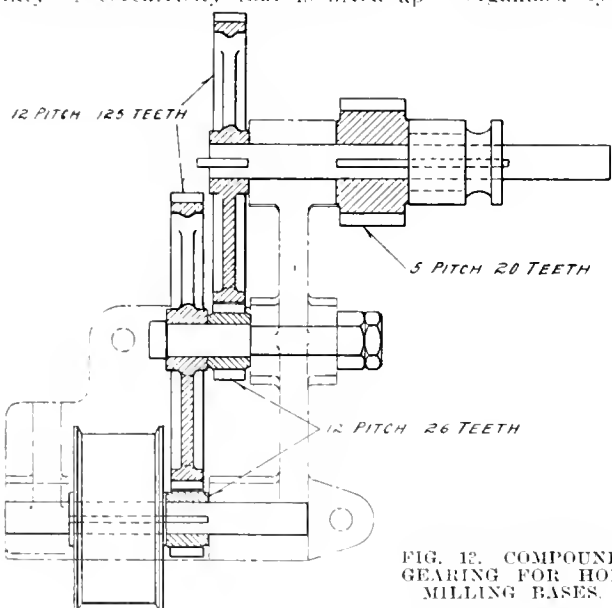

FIG. 13. COMPOUND GEARING FOR HOB-MILLING BASES.

arent in other methods. Several C.M.C. lathes are fitted up for this work. After finish turning with the tools held in the ordinary tool post, the cross-slide is re-

are an economic factor to be reckoned with. They are adaptive, keen, take an interest in their work, and carry out same with vim and enthusiasm.

Grinders as Machine Tools.—Shell grinders were imported to the United States from Canada at the ports of Buffalo and St. Albans, Vt., by C. J. Tower and P. McGettrick for the account of the Ford-Smith Machine Co., Hamilton, Ont. The collectors at the ports named classified the grinders as "manufactures of metal not specially provided for," and took duty at the rate of 20 per cent. The contention of the importers, sustained by evidence, was that entry should have been given at 15 per cent. under the provision in the present tariff for "machine tools." Judge Fischer held the grinders had been shown conclusively to be "machine tools" within the generally accepted and tariff sense of the term. The protest was sustained.

Son—"Mother, can I go with pa?"
Mother—"No, Willie, you are too young to listen to your father play golf."

Percussion Fuse Production with Female Labor Prominent

Staff Article

The increased production of high explosive shell has naturally created a demand for detonating fuses. To meet the exacting constructional requirements of the latter, both as to quality and quantity output, constitutes perhaps a more onerous undertaking than does that of manufacturing the various types of shell bodies. Enterprise, backed by proper organization, can, however, always win success. This is evidenced through the data following.

CONDITIONS in the metal-working industries at the present time have compelled plant owners to employ female help for all classes of service, and this is probably more pronounced in the fuse feature of munitions work than in any other, not only because

required. A large hall fitted with wash-basins and cloak lockers, has also been installed. As accidents are incidental to machine shop work, the firm have equipped a small room with every facility for "First Aid" service, a trained nurse being in charge continuously.

the turret is completed every half minute and a fair average production from each machine may be taken as about 120 per hour. The portion of the fuse machined at this setting is the lower end that screws into the nose of the shell. The cycle of operations is:—Chucking on the first, or top spindle; the second spindle being tooled to rough-off the four surfaces, outer and inner diameters, face and platform. The third spindle tools finish the above portions and also cut the platform recess; the fourth spindle cuts the recess at the base of the inside bore, while the fifth and last stage is to cut the threads on the inner and outer diameters. This last operation is accomplished with collapsible taps and dies, both being gripped in the one turret holder. The machining on this portion of the fuse is completed at four strokes of the turret spindle, and after the four spindles are in operation, a casting is inserted and a finished piece removed at each movement of the turret spindle.

Each fuse is carefully gauged and examined by inspectors as it is taken from the machine; one inspector being placed at each machine and being held accountable for all the work passing through his hands. To prevent the misunderstanding that often results from verbal instruction, each inspector is furnished with a typewritten sheet covering the specific directions that govern his work of examination. The first gauging is that of the cone length on the underside of the platform, to see that sufficient stock remains for the following operation. The length of the screw from the platform seat to the lower face must be



FULLY EQUIPPED "FIRST AID" DEPARTMENT

of the lighter nature of the work, but also due to the fact that girls and women are, in many respects, better fitted than men for those operations where a sensitive and delicate touch are essential to economic and quality production. Such a circumstance, however, has created executive problems, involving, among others, drastic changes in the whole atmosphere associated with mechanical engineering shop practice, in order to solve the question of suitable environment for the class of help now employed. While favorable conditions may not prevail in all establishments where "diluted" labor is employed, the plant from which the following article was derived has at least put the comfort and accommodation of all its employees on the same level as that of the material production, realizing that the best in the latter respect can only be achieved under satisfactory working conditions. Owing to the tedious nature of the work, the management have provided a large rest room for the convenience of the girls, and periodical intervals of fifteen minutes each are allowed each girl in order that she may return to her place refreshed and be better fitted to perform the duties re-

Machining the Lower End

The first machining operation is performed on several New Britain, 5-spindle automatics. Work progresses on four spindles at one time, while the fifth is free to remove the finished piece and insert a rough casting. The round of



FIG. 1 "NEW BRITAIN" AUTOMATICS ON FIRST OPERATIONS

between 1.155 inches and 1.145 inches. The angle of the platform is very important; a perfect angle is desirable, favoring the bearing of the gauge on the outer edge. The gauging of the thread is done with a ring gauge which must be a good fit; thread must be parallel, but not required to go to the shoulder. The 1.99-inch snap gauge must not pass over any part of the thread, as the exact size is obtained on a subsequent hand-sizing operation. The neutral depth to the shoulder of the adapter recess should be .450 inch, with a tolerance either way of .005 inch; the width of the recess at the base of the adapter chamber being .071 inch, with a diameter not greater than 1.39 inches. Care is required in gauging inaccessible parts in order that chips, etc., do not give a false reading. Indicating calliper gauges are used to measure diameter of recess. The low limit plug gauge must not enter the adapter thread, this being sized at a later stage. The fuse is also gauged for overall length to insure cleaning up on following operation. In addition to actual gauging, inspectors are required to examine for visible irregularities; the platform must be perfectly smooth without any signs of chatter marks; threads must be clean cut and free from roughness, and burrs left from tools must be eliminated.

Defective fuses are discarded and recorded as early as possible, and doubtful cases are decided by the chief inspector. Each inspector is provided with an identification stamp, which he puts upon all fuses that pass through his hands and forwards to the next operation. By this method a check is kept upon the work of each individual inspector. Defect forms are filled out each day by all inspectors, recording the number of fuses rejected and the reasons for so doing.

Drilling and Tapping Adapter Screw Hole

This operation is accomplished on a double spindle Henry & Wright drill, fitted with a swivel jig and a modern tapping attachment. The jig on this

drill, and also others where two operations are performed at the one setting, are arranged to swing from a pi-

the bar acting on a roller secured to the tool block. After spotting, which consists of drilling a short distance into the

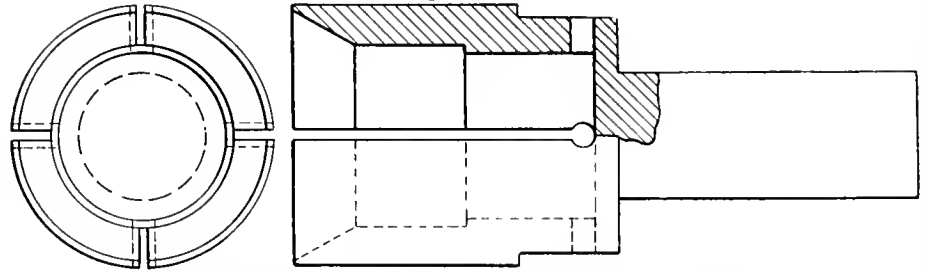

FIG. 3. SPRING HOLDER FOR PLACING FUSE IN CHUCK.

not pin in the table located at an equal distance from the projected centre of each spindle. Following this operation the large threads are sized by hand tapping. Collapsible taps are used for the purpose, being secured to the bench. The dies and taps are each fitted with a very efficient device for maintaining the fuses in the correct position, so as to avoid any possibility of crossing the thread when starting in the die. This attachment consists of an inserted bush placed in the bore of the chuck; slots being cut to permit jaws operating and to allow bush to protrude above the surface to a height sufficient to allow platform to rest on the top. This guiding bush is forced upwards by means of a spring, and the vertical action eliminates all chances of crossed threads.

Machining the Cone Portion

The machining on the cone portion of the fuse is performed on Stecher turrets, several of which are installed for the purpose, Fig. 2 showing one of these in operation. The sequence of detail machining consists of rough turning the cone, spotting, finish cone, serrations and groove, and lastly, ream and face. The roughing out over the surface of the cone is done with a single point tool held in a slide at the desired angle of 19 degrees and 35 minutes with the axle of the fuse. This tool slide is operated by a bar held in the face of the turret,

nose, the cone is finished with a broad nose tool, at the same time cutting in the serrations and groove. The next operation is to drill the hole complete-

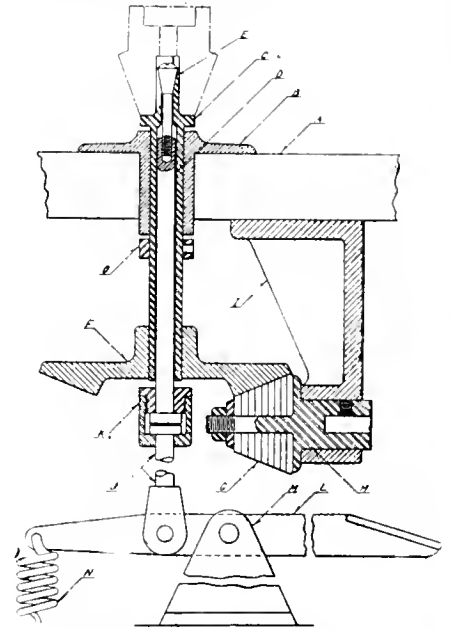

FIG. 4. DEVICE FOR REMOVING BURR FROM EDGE OF PLATFORM.

ly through and enlarge the outer portion. The hole is finally reamed slightly smaller than the finished dimension. The end is also faced at this setting, the overall length to be 2.6 inches, a tolerance of .006 inch being permitted above or below. As the central hole is subsequently reamed, the low limit gauge must not enter. It might be here stated that all working or shop gauges are made within the limits of the check gauges, and while greater accuracy is required while work is in progress, the rejections from Government inspection are materially reduced.

A noteworthy feature in connection with the body finishing operations is the method adopted for placing the semi-finished fuses in the pneumatic chucks on the Stecher machines. For economic production it is essential that the machine be operated continuously, and as it is a dangerous practice to place rough pieces in a rapidly moving chuck, the simple device shown in Fig. 3 is used. This is a piece of mild steel machined out to fit the rough nose of the



FIG. 2. STECHER TURRETS FINISHING FUSE BODIES.

fuse, with four slots cut in to serve as a spring grip; the shank being turned to fit the hole in the turret. Fuses are removed from the chuck by releasing the pressure when the finishing reamer is in the hole. The gauging instructions for inspectors on these machines are issued in printed form and are as exacting as those previously mentioned. The neutral diameter of the outer extremity of the platform is 2.387 inches, with an allowable variation either way of .013 inch. The depth of the pellet hole is very important, the tolerance permitted being only .010 inch in a length of 1.5 inches. The thickness of the lip below the groove must be between .03 and .04 inch.

Removing Burr from Edge of Platform

The slight burr at the outer diameter of the platform, which is unavoidably caused by machining, must be removed, for which purpose the machine shown in Fig. 4 has been developed. Speed of handling parts is an important factor in the manufacture of fuses, in which connection the rapidity of action of this machine is a commendable feature. Inserted in the bench is the bronze bush B, through which the vertical spindle C passes. The upper end of this tool steel spindle is turned to fit the pellet hole of fuse, and three slots are cut in to give it the expansion qualities. The action of this delicate chuck is controlled by the treadle rod D, and the tapered bolt E. Secured to the lower end of the vertical spindle is the large friction gear F, which is driven by means of the small pinion G, made of leather washers and placed on the short shaft H, which is supported by the bracket hanging from the lower surface of the bench. The treadle rod is so constructed that the lower portion remains stationary while the upper section revolves, the connection being by means of the point collar K. It will be noticed that the device is designed so that the force required to

expand the chuck and revolve the work is derived from the weight of the gear and spindle, and the tension of the spring N. This arrangement eliminates the possibility of too great a pressure being put upon the split chuck, which would arise if the treadle rod were depressed by means of the foot lever.

Detail Operations

While the detonating fuses may not be as complex as the time fuses, many of the details require an equal degree of accuracy, both as regards machining and gauging of the various parts. With the exception of the foregoing operations, the bulk of the work on the fuses is accomplished on vertical drill presses, equipped with jigs or fixtures for specific operations. A row of these machines, single and double, Henry & Wright, are shown in Fig. 5. Drilling the detent hole and counterboring for tap is performed on a double spindle drill, both these operations being done at the one setting, the jig being pivoted to bring the hole central below each drill spindle. The detent hole, having a high limit of .223 inch and a low of .217 inch, is drilled to a depth not exceeding 1.425 inches from the bottom of the adapter recess, the exact depth being determined at a later stage. The counterbore for tap has a maximum depth of .205 inch,

measured from the same base as the detent hole, the low limit being 0.010 inch. The next machine, a single spindle drill, is used for drilling the small hole

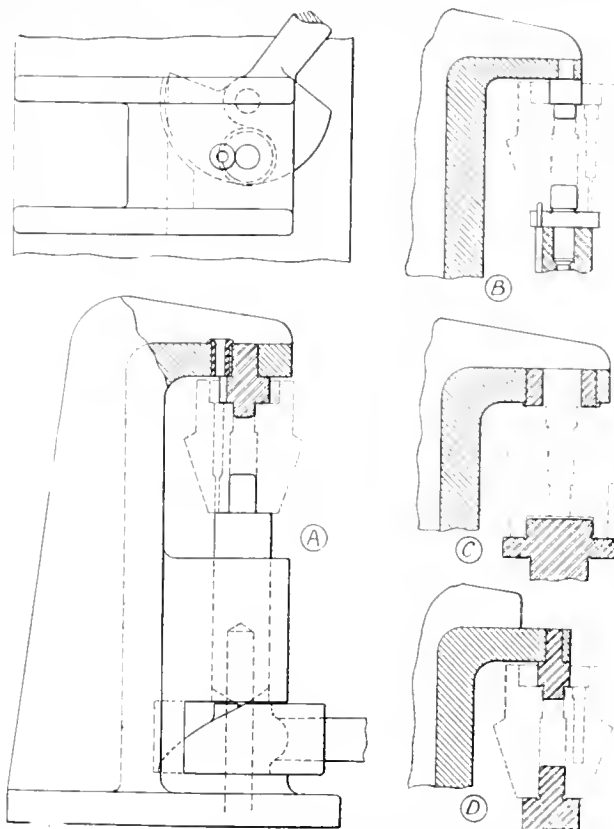

FIG. 6. FIXTURE FOR DRILLING AND COUNTERBORING FUSE HOLES.

for the detent spindle. The point at the bottom of the detent hole acts as a guide for the small drill, which must leave the diameter between .082 and .088 inch, and have the same axial line as the larger portion. The jig used for this operation is shown at A, Fig. 6, while the other views of this figure show the application of the same design to the various requirements of the different details. At B is illustrated the jig adapted for tapping the detent hole, a small pin being placed in the anvil to locate the fuse in the correct position. At C is shown the jig arranged for counterboring the cap recess, while D is that for tapping the detent hole. The elevation of the anvil is obtained by means of a helical cam operated by a horizontal lever, and it will be noted that gauging positions are all located at points from which the inspectors gauge for finished dimensions.

Counterboring Detent Hole

Another jig used for counterboring the detent hole is shown in Fig. 7, the action being similar with the exception that the motion of the anvil is obtained from the vertically operated lever C, the anvil B being of fairly large diameter to protect the moving shaft from falling cuttings.

The graze pellet hole is now reamed to the finished diameter, which must be between .535 and .54 inch; and by means of a milling cutter secured to the reamer, the fuse is faced off to the exact

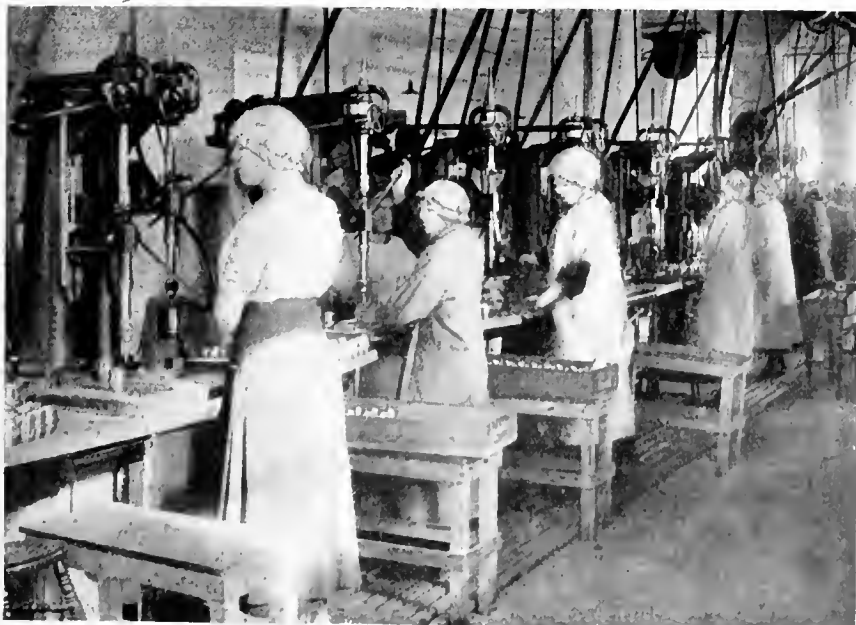

FIG. 5. BATTERY OF "HENRY & WRIGHT" DRILLS ON BODY DETAIL OPERATIONS.

overall dimension. The lower end of the detent hole is squared off to form a seat for the detent, and also to form a shoulder that will not fail to lock the detent

the purpose of holding the fuses. It may be stated here that while the drawing specifies recesses at the base of the small screw holes, an optional me-

shown in Fig. 8, and is used on a two-spindle Henry & Wright drill. It is swiveled in the same manner as those previously described; the drilling of the bolt hole, which is .208 inch diameter, having a tolerance of .003 inch either way, is performed on one spindle, while the counterbore is accomplished on the adjacent spindle. The depth of the counterbore measured at the shallow portion must not exceed .205 inch, the neutral distance being .2 inch. The clamping spindle A, of the jig is provided with a locating pin B, that enters the detent hole of the fuse, the clamping spindle being guided by the key bolt C. The spindle is advanced by swinging the cam lever D and is returned by the link E. Owing to the angle at which the drill must enter the work, the guide bush F is beveled to provide better support for the drill when starting. Extreme care is exercised in having the hole accurate. jig and gauges are therefore checked daily.

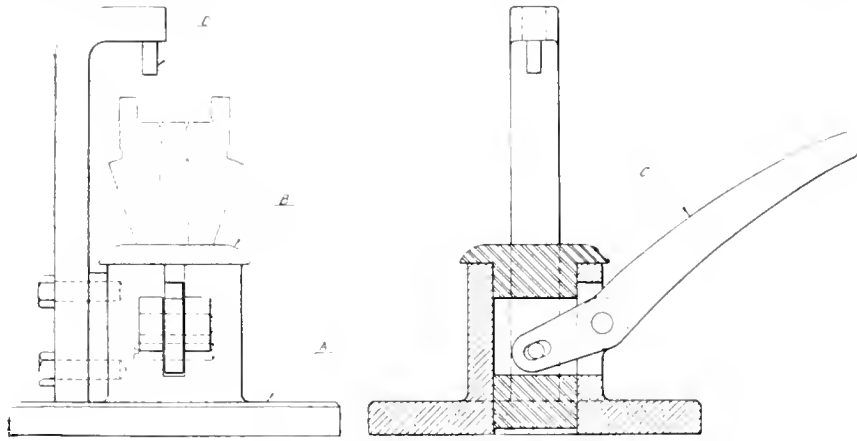

FIG. 7. FIXTURE FOR COUNTERBORING DETENT HOLE.

spindle when in action. The wrench hole is next drilled, the dimensions to be a diameter of .235 inch with a high and low tolerance of .005 inch; the depth of the hole not to exceed .38 inch at the shallowest portion. The centre of this hole must be between 1.13 and 1.15 inches from the upper or nose end of the fuse. The recess for the brass washer is the next operation, and a tolerance of .005 inch is allowed on a maximum diameter of .56 inch. The same tolerance is permitted on the depth, which must not exceed .085 inch. Following this operation the fuses are passed to another jig on the same double spindle drill, where the undercut at the base of the cap recess is cut in. A special tool has been designed for this work, where the small cutter is contained in a holder and is lowered to the proper position, being gauged by a collar resting on the nose of the fuse. As the drill spindle continues downwards, the tool is forced outwards by a taper attachment con-

thod is permitted, by which the undercut may be omitted, and a screw with a pilot used to overcome the portion at

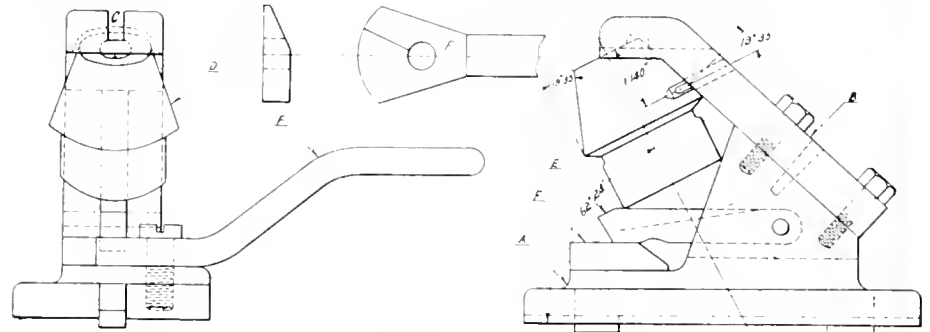

FIG. 9. JIG FOR SLOTTING FUSE NOSES.

the bottom of the hole that cannot be cut to a full thread.

Drilling Centrifugal Bolt Hole

The next operation, that of drilling the centrifugal bolt hole, is a very im-

Tapping Cap Recess
Tapping the cap recess and also the small plug holes at the entrance to the

detent and centrifugal bolt holes is accomplished much in the same manner as the adapter set screw hole described at an earlier period. The minimum diameter of the cap screw thread, 24 to the inch, R. H., is .16 inch, with a tolerance above this dimension of .003 inch. The plug holes have a similar tolerance on a mean diameter of .3 inch. A feature that might be mentioned here is the method of handling the fuses as they progress through the shop. The drilling machines on the detail operations are so arranged that the fuses are passed from one girl to the next, often without the necessity of putting it down, although pocket trays are located between each machine in which the fuses may be placed. These trays are made of wood to avoid injury to the semi-finished work while in transit.

The small angular groove at the outer edge of the nose is next milled-in. The purpose of this detail is to lock the cap in position after final assembling. Cutting this small groove is accomplished on a Whitney milling machine, the jig used being shown in Fig. 9. To the base of the jig, which is secured in a permanent position to the table of the milling machine, is secured the piece B, the upper portion acting as a locating point and also as a guide for the cutter, which

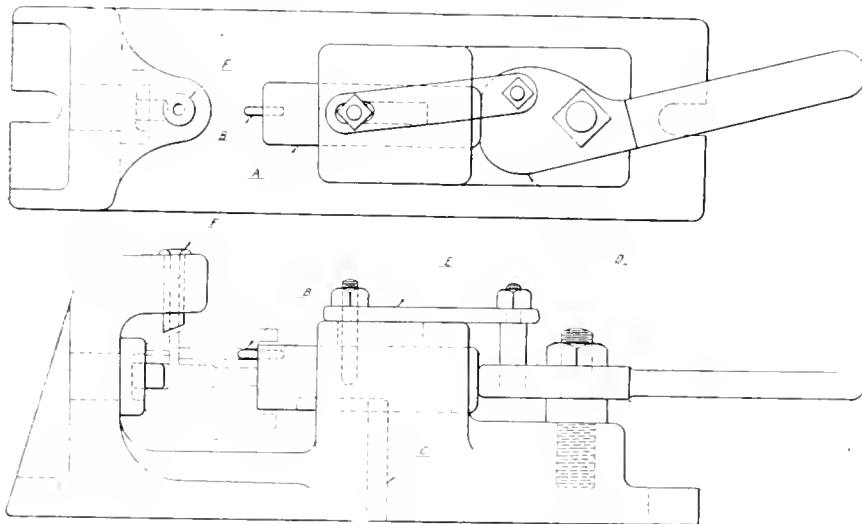

FIG. 8. JIG FOR DRILLING CENTRIFUGAL BOLT HOLE.

tained in the body of the fixture and acting behind the tool. Jigs similar to those illustrated in Fig. 6 are used for

portant one, owing to its position in the fuse and the duties it is called upon to perform. The jig for the purpose is

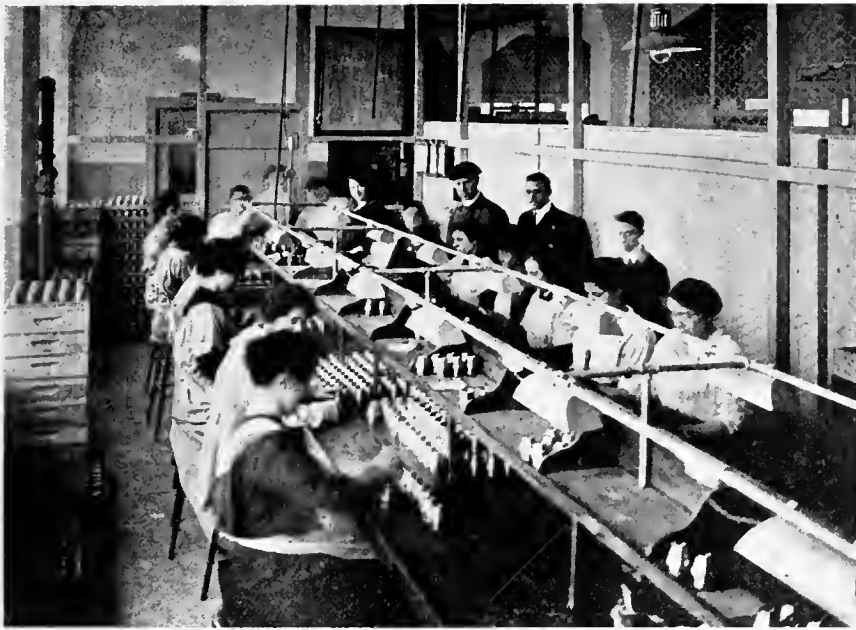

FIG. 10. FINAL INSPECTION ON FUSE BODIES.

operates through the groove C. The position of the groove in the fuse is determined by placing the wrench hole on the pin shown. The fuse is locked to a working position by the swing clamp E, acted on by the cam lever F.

Marking the Fuses

A Dwight-Slate marking machine is used to put the identification marks on the fuse, these being rolled in just below the serrations. After the fuses have been buffed and polished, they are washed and otherwise made ready for final inspection.

A view of the final inspection on the fuse bodies is shown in Fig. 10. This

table and gauging is under the direct supervision of several inspectors. Every facility has been provided for the rapid and accurate gauging of the various details. In addition to the pleasing environment, the chief inspector and his assistants are ever on the alert to devise methods to minimize the labor necessary in the handling of thousands of pieces each day. As an example of the ingenuity displayed in developing rapid production fixtures, the sketch, Fig. 11, illustrates a device designed by the chief inspector which greatly facilitates the gauging of the threads on the shell end of the fuse. This arrangement has materially reduced the physical exertion

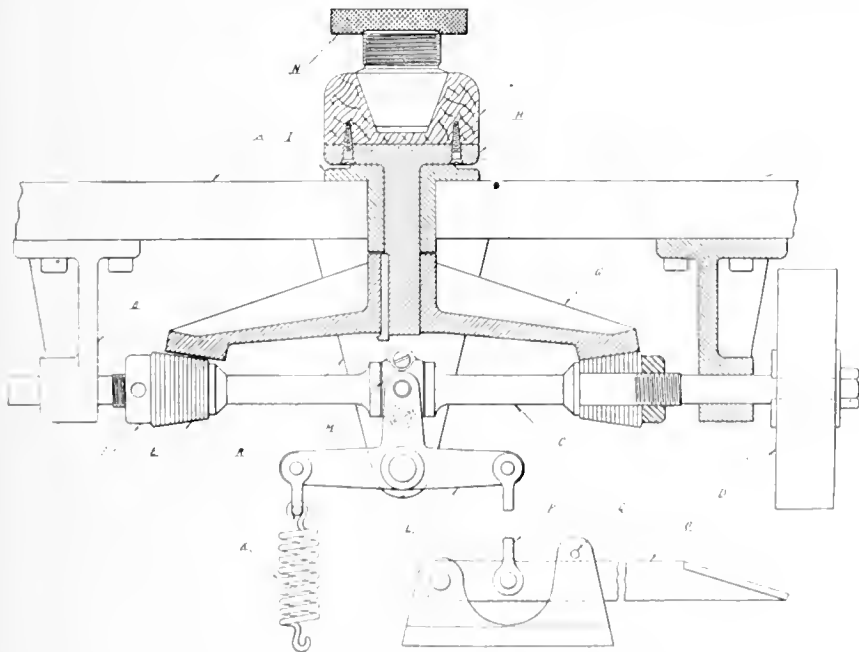

FIG. 11. GAUGING MACHINE FOR FUSE THREADS.

room is closed off from the rest of the workshop and no one is allowed in unless their duties demand it. The girls are arranged along either side of the

that would otherwise be required if the gauges were screwed on by hand. The driving shaft C, driven by the pulley D, is supported by the hanging

brackets B. The two built-up leather pinions E, are located an equal distance on either side of the centre of the fixture. Secured to the lower end of the vertical shaft is the large friction gear G, the upper flanged end H carrying the wooden friction chuck block J; the whole revolving in the bush I. The tension of the spring K, operating on the double end bell crank lever L, causes the shaft C to be forced to the left, thus bringing right hand pinion in contact with the large gear and revolving fuse in a right hand direction. The gauge N is started on by hand, and is then placed in the block, when the ring threads its way to the platform of the fuse. Should the ring, for any reason, fail to go to the desired position, the fuse will slip in the block, thus preventing seizing of the gauge. The action of the spring will always revolve the spindle in the one direction, but, if it be necessary to stop the machine the treadle can be locked in a neutral position by means of a pin inserted in the hole Q. While the gauging of these parts is not strenuous work, much of the irksomeness has been removed by the use of this device.

Owing to the high degree of accuracy that is required, the best of lighting is essential for inspection purposes. The room is provided with spacious windows and artificial light is arranged to minimize the eye strain, the beams being reflected on the work, while the eyes of the operators are protected from the direct rays of the lamps.

Detail of Fuse Parts

Before passing to the assembling room it might be well to give a brief description of the various details, as shown in the assembly, Fig. 14. At A is seen the graze pellet that carries the detonator. This piece has an overall length of .97 inch and a maximum body diameter of .53 inch. The upper end has two shoulders, one for the locking position and the upper as a seat for the creep spring. At B is shown the centrifugal bolt, the maximum dimensions being .202 inch diameter and .245 inch long. The detent spindle is shown at C, and the container at D, the overall length of both being .65 inch; the mean diameter of spindle is .076 inch, and that of the container .2125 inch. The detent spring E is made from steel piano wire .026 inch diameter, and must contain 13 1/2 coils in a length of between 1.3 and 1.15 inches, after 12 hours of complete compression. This spring must compress to a length of .45 inch under a weight of 6 lbs. 8 oz. The graze pellet plug H, secures the detonator in position; its diameter being .215 inch, with the exception of the thread which is .298 inches in diameter and 24 threads per inch. The creep spring I retains the graze pellet in position after the centrifugal bolt has been displaced, and until the shell strikes an object. The action of the mechanism will be described later. This spring is made of steel piano wire .02 inch diameter, there being 6 1/2 coils in a length of .99 inch; the spring must compress to a length of .48 inch under a weight of

91 $\frac{1}{2}$ oz. The cap J fits on the nose and contains the striking needle. The cap has an overall length of .9 inch, measured from the edge of the counterbored hole, the length of threaded portion being .35 inch. The steel striking needle K is probably one of the details that is given the greatest attention as regards gauging for length, which must not exceed .76 inch from the shoulder of the head to the striking point. In fitting these needles in the caps, special care has to be exercised in assembly, and, to emphasize the fact to the girl operators, a special notice is posted above the bench calling attention to the fact that all needles must be screwed in tightly and in no case must they be eased back in order that gauge may fit, because a loose needle may have serious results to those in charge of the firing operations. At L is a distance piece made of pressed paper, and at M is a small brass washer. At N is the adapter containing the magazine Y. The details X and Y are placed at the filling base and do not enter into the manufacturing contract.

Detonator and Magazine

The detonator X consists of a small cylinder made of copper .022 inch thick, with an external maximum diameter of .225 inch, the hole in the upper end being .1 inch in diameter, and that on the bottom .05 inch. A copper washer .022 inch thick is placed inside the upper surface, and below it a thin brass disc, .022 inch thick; on the inner bottom there is also a brass disc .001 inch in thickness and between the two brass washers is contained the 1.7 grains of detonating composition. The magazine Y may be fitted with or without delay as desired, and consists of a .01 inch disc of delay composition (pressed 400 pounds dead load), contained between a perforated powder pellet and a brass fitting, these being located centrally in a tin cup of .82 inch diameter, and .26 inch deep. On the inner bottom of this cup is a

thin white paper disc, and on the outside a muslin disc. On the outer upper surface is a tycoon paper disc covered with a lasting cloth washer, the whole

from one operation to the next as each detail is performed, the movement being continuous. The table is divided into two sections, and at the end of each di-

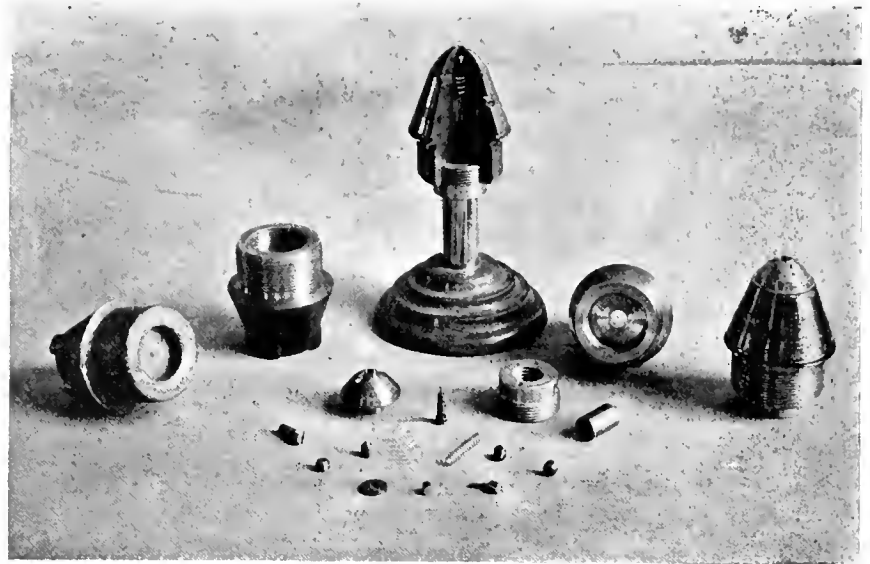

FIG. 13. VIEWS OF FUSE AND ITS COMPONENT PARTS.

being shellaced together and to the tin cup. The intervening space is filled with 25 to 30 grains of F. G. powder.

Assembling Department

Fig. 12 is a general view of the assembling department, and the layout and method adopted is an interesting feature of the plant, being as it is an efficient factor in the rapid assembly and inspection of the various fuse parts. The girl operators and men inspectors are arranged along one side of a long table, the fuses being passed from one girl to another, each having her allotted duties to perform in the progressive assembling of the numerous parts. The fuses are placed in small pocket trays, each holding six fuses, these being moved

vision the empty trays are placed on inclined runways and returned to the starting point. The continuous nature of the operations is such that several spare girls are required for relief purposes. The sequence of operations as the fuses advance along the bench are indicated on the general assembly, Fig. 14, in alphabetical order:—

- A.—Boy tilling trays and dropping in graze pellets.
- B.—Putting in centrifugal bolt.
- C.—Putting in detent spindle and container.
- D.—
- E.—Putting in detent spring.
- F.—Screwing in detent plug.
- G.—Screwing in centrifugal bolt plug.
- H.—Screwing in pellet plug.
- I.—Placing in creep spring.
- J.—Screwing in cap. (Steel needle fitted in in another department).
- L.—Putting in paper cylinder.
- M.—Putting in brass washer.
- N.—Putting in adapter.
- O.—Screwing in adapter plug or set screw.

These set screws are screwed in by means of a simple jig that holds the fuse in a certain position with the screw opposite a fixed crank-operated screw driver. Two small, weighted lever bench presses are used to stencil the Lot Number, and Government Acceptance Stamp.

Before passing to the lacquer preparation table, the fuses are carefully examined by shop inspectors. After lacquering, they are given a final Government inspection preparatory to packing. Minor repairs are made at this time, but where fuse assembly does not conform to specifications, they are placed in separate cases and taken to another department for overhauling and correcting. It might be mentioned that, at various points along the assembly bench, Government inspectors are placed to check

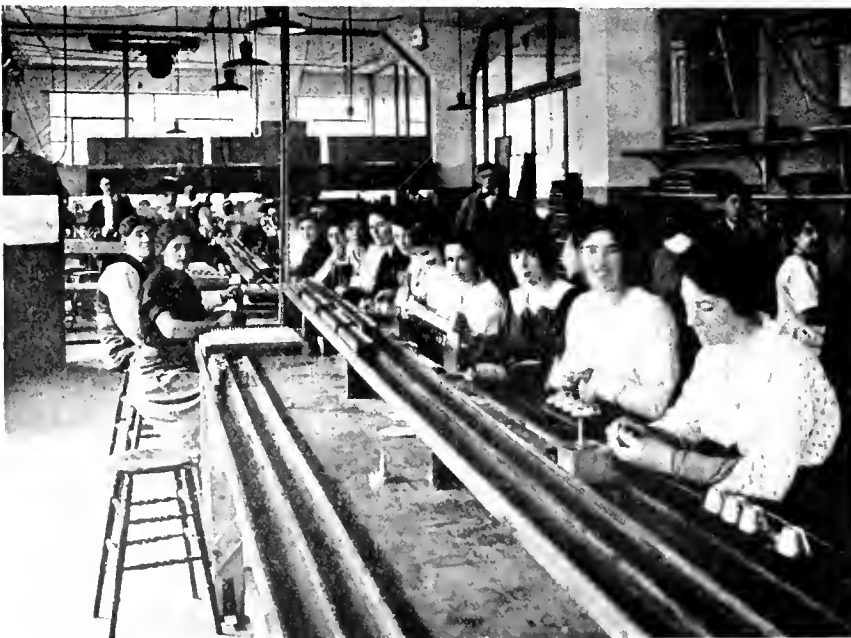

FIG. 12. FUSE ASSEMBLY DEPARTMENT.

the work as it progresses. It has been found, however, that with the close working limits that are in vogue in the actual evolution of the finished fuse body the percentage of rejected fuses is remarkably low. In this respect, it might be well to add that manufacturers in many instances, obtain the various small details from outside sources. In order, therefore, to eliminate the possibility of subsequent error, every component part used in the fuse construction, is carefully gauged and examined before going to the assembling department. Several views of the semi-finished fuse, together with the small details, are shown in Fig. 13, while Fig. 14 gives the more important dimensions and also shows a cross section of the fuse through the centre of the graze pellet and detent holes. Fig. 15 illustrates some of the gauges that are indispensable for accurate production. The group here shown is understood to cost well over \$5,000, the large one in the background costing over \$200.

Mechanism in Action

The purpose of the various details may be better understood by a brief description of the action under firing conditions. With the fuse is assembled, the detonator cannot be fired until the graze pellet is released. In order to do this the centrifugal bolt must be removed from its position on the shoulder of the graze pellet, and, to do this, the detent must be forced down into the space now occupied by the detent spring. When the shell is discharged from the gun, the sudden and violent movement causes the small detent C and D to exert a pressure of over 25 lbs. upon the spring E, and consequently compresses it until the detent spindle is below the shoulder, when the revolving motion of the shell created by its passage through the rifled barrel, results in the point of the detent spindle tipping over to the outer edge; the reaction of the spring causes the detent to lock, thus preventing it again entering the small

hole. As soon as the detent spindle has unlocked the small bolt B, the centrifugal action has the effect of making the centrifugal bolt fly out, leaving the graze

In January this year there was also an increase over the same month a year ago. Exports in 1917 were \$16,911,008, as against \$16,455,973 in January, 1916.



FIG. 15. SOME OF THE GAUGES USED TO SECURE ACCURACY IN PRODUCTION.

pellet free to advance. As long as the shell is flying through space, however, and more especially when falling downwards, the graze pellet is prevented from creeping by the action of the small spring I. Immediately the nose of the shell strikes an object, the graze pellet will bound forward and the detonator, coming in violent contact, fires the charge, which is then transmitted either instantaneously or by means of the delay, to the explosive charge in the shell.



BRITAIN'S EXPORT TRADE

DESPITE the unrestricted German submarine warfare, Britain's exports to America during the month of February show a considerable increase over those of February a year ago. During February, 1917, exports from London to America reached the aggregate of \$14,061,276, as against \$12,371,166 for February, 1916, an increase of \$1,690,110.

or \$455,935 more. Exports for January and February this year from London to America aggregate \$30,972,284, as against \$28,827,139 in the same months last year, an increase of \$2,145,145. The figures are those of exports going out of England through London alone; there is of course a considerable export going direct from Liverpool and other ports without touching London.

Of exports in two months this year from London, the biggest item is rubber, of which \$10,000,000 worth was sent to America after being received from Africa and other British rubber producing parts. Art exports, including paintings aggregated \$1,904,400 during January and February this year, as against \$1,259,087 in January and February last year.



ENGINEERS ORGANIZE FOR NATIONAL SERVICE

ENGINEERS and technical men generally belonging to the various branches of the profession in Ontario have recently organized to lend their practical and technical knowledge in the service of their country. A joint committee is making a canvass to register engineering ability of every sort and description, and cards have been distributed to the members of all the societies, asking for accurate information as to each man's special experience and qualifications.

The object of the committee is to devise ways and means by which engineers and other technical men may, as a result of their special training and experience, render assistance in the development and government of our Dominion. The immediate aim is to evolve a plan or plans whereby such of these men as for business, family, or other reasons, are unable to go to the front, may be used for war purposes at home in such manner as their special technical training may make them most valuable.

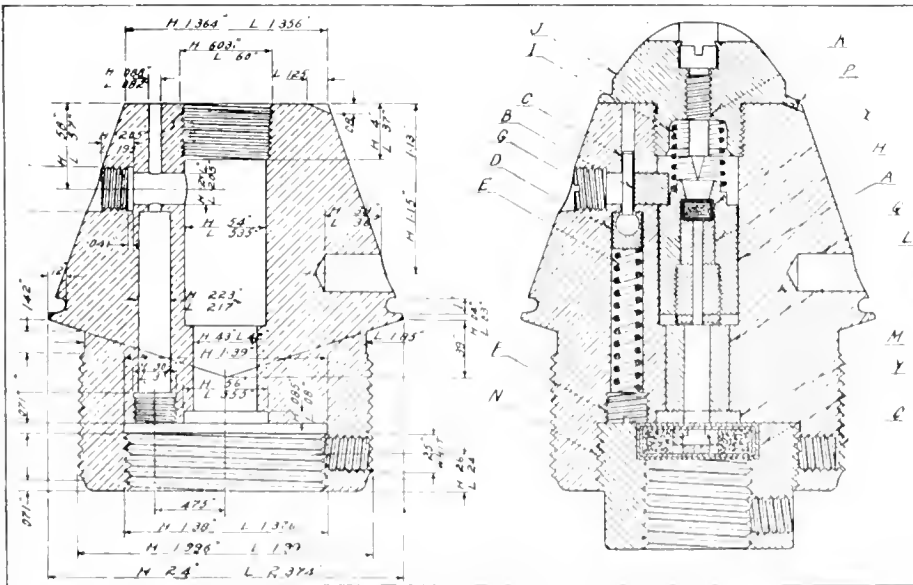

FIG. 14. DETAIL OF FUSE BODY AND GENERAL ASSEMBLY

OUR MINERAL AND FOREST RESOURCES

THE Dominion Royal Commission now closing the fifth year of its existence has recently issued what is understood to be its final report. Along with the latter appears the fifth interim report, the subject of which is Canada, and concerning the ownership of whose mineral resources the following statement is made:—

The Commission finds it regrettable that Canada's mineral assets should be owned so largely outside the Empire, and adds that the present income received by the various Provincial Governments for the loss of their mineral wealth—a most valuable and ever-wasting asset, appears wholly inadequate. The taxation is quite insufficient in comparison, for instance, with that levied in the Union of South Africa.

Forest Assets

The forest resources of Canada, the Commission admits, undoubtedly form one of the most valuable assets of the Empire. It doubts whether the provincial and federal forest reserves are as yet under an efficient and economic administration worthy of the vast natural wealth which they represent. It is pointed out that Canada is estimated to have between two and three hundred million acres of commercial timber, but the output is approximately only that of Germany, where timber is cut on an area of 24,000,000 acres only. The German output however, is from lands which have taken a hundred years to bring to their present perfection, as timber producers.

"The possession of assets such as the Canadian asbestos and nickel resources could be used by the British Empire as a powerful means of economic defence. We desire to point out that, though Canada is practically the only producer of raw asbestos on a large scale in the world, the United Kingdom is largely dependent on foreign sources, especially the United States, for the manufactured asbestos which it requires."

The commission emphasizes the fact that the water powers of Canada should place the Dominion in a favorable position for the production of synthetic nitrogen compounds, while the manufacture of potash from felspar by a hydro-electrical process in Canada is contemplated.

Empire Resources Development

"The success of the action achieved during the war suggests that it is expedient that the various Governments of the Empire should take steps as soon as conditions permit," says the report, "to secure the development and utilization of their natural wealth on a well-considered scheme directed towards a definite and recognized object. In our opinion it is vital that the Empire should, so far as is possible, be placed in a position which would enable it to resist any pressure which a foreign power or group of powers could exer-

cise in time of peace or during war in virtue of a control of raw materials and commodities essential for the well-being of the Empire and it is towards the attainment of this object that co-ordinated effort should be directed."

The commission has made a survey of the natural resources, commercial and industrial effort, and man-power of the Empire, and advocates the completion and continuance of the work under a permanent Imperial Development Board representing all parts of the Dominions which should keep this survey up to date, so that there may be a scientific development of the natural resources of the Empire.



QUESTIONS AND ANSWERS RELATING TO MUNITIONS

Question.—What is the purpose of the serrations on the forward portion of the copper bands on the large size shells?

Answer.—The guns from which these shells are fired are generally discharged at a considerable angle, the guns being brought to a horizontal position for reloading. When the shell is placed in the breech it is given a violent push forward and the serrations in the copper band provide a better means of starting the band in the rifling of the barrel, so that the hold thus attained will support the weight of the shell when the gun is tilted upward.

Question.—An air cylinder 10 inches in diameter is used to feed the saddle of a lathe when drilling a shell nose. If the gauge registers 70 lbs., what thrust is put upon the lathe spindle, provided 2 per cent. is used to move the saddle?

Answer.—The total force acting on the piston would be represented by the initial pressure multiplied by the area in square inches, or $70 \times 10 \times 10 \times .7854$ equals 5497.88 lbs. As this includes the force required to move the saddle, the net pressure acting on the lathe spindle will be 98 per cent. of the total, or 5497.8 lbs. $\times .98$, equals 5388 lbs.

Question.—What dead weight would be required for an accumulator to exert a pressure of 1,000 lbs. per square inch, the piston being 12 inches in diameter?

Answer.—The area of the piston upon which the pressure would come will be the diameter squared multiplied by .7854, or $12 \times 12 \times .7854$ equals 113.098 inches, and as each square inch must be subjected to a pressure of 1,000 lbs. per square inch, the weight required will be 1,000 lbs. multiplied by 113.098, or 113,098 lbs., which will be approximately 57 tons.

Question.—What rule can be applied to calculate the amount of stock to be removed from the base of a six-inch shell, when the same is overweight?

Answer.—A fairly accurate formula for calculating the weight of round

steel per foot of length is to divide the square of four times the diameter by 6. Thus for 6-in. steel the weight would be $\frac{(4 D)^2}{6} = \frac{(4 \times 6)^2}{6} = 96$ lbs.

per foot. To find the weight by sixty-fourths of an inch, divide 96 by the number of sixty-fourths contained in one foot, or 96 divided by 768 equals $\frac{1}{8}$ of a pound, or 2 ounces. Therefore, each two ounces would correspond to a cut of 1-64 inch from the surface of the base.

Question.—If the inner and outer walls of a shell were not concentric, what effect would it have on the flight of the projectile?

Answer.—The fact that a shell in flight has two distinct motions, that of the path of the projectile and the rotating motion about its own axis, requires that the closest attention be given to the production of a perfectly uniform shell to insure the highest degree of accuracy result. Should the walls of a shell vary in thickness on the same circumference, the weight would be unevenly distributed, and the centrifugal force set up by the rotating action would cause the shell to travel in ever-increasing spirals in the course of its flight. The principle is similar to the unbalanced pulley on a rapidly revolving shaft.

Question.—Why are the threads on the base plugs or adapters cut left hand, while those on the sockets are cut right hand?

Answer.—In order to increase accuracy of fire, all modern guns have rifled barrels; that is, a series of helical grooves running throughout the entire length, so that when a shell is discharged the copper band cuts its way through, causing the shell to rotate about its own axis at a very great speed. Unless the adapters were screwed in the base in the contrary direction to the action of the shell when in flight, the possibility of turning out would be very great, more especially if the adapter were a little loose. With a left hand thread, this danger is eliminated. It is, therefore obvious that all threads forward of the driving unit (the copper band), will be right hand and those to the rear will be the contrary.

Question.—Why are the copper bands on the large shells heated before being pressed in the grooves?

Answer.—In order to overcome the inertia of the mass of the shell, together with the important duty that is required of these bands when the shells are discharged from the gun, it is essential that no slippage take place between the shell and the copper band; it is therefore necessary to heat the larger sizes to insure the metal being forced well about the waved ridges and into the undercut. The contraction of the metal when cooling, also aids in the copper taking a firmer grip of the shell.



Shrapnel Shell Manufacture

Featured by An Installation of Special Equipment

Staff Article

Whether in the matter of forging or that of machining, it can truthfully be said that the various stages of shrapnel shell production continue to provide unusual scope for the display of inventive genius and mechanical engineering skill of a very high order. That the latter have not been lacking in the past, we know, and that their further development may be looked for in the future, will, we are sure, be a reasonable conclusion to anticipate.

SUITABLE equipment is undoubtedly the chief essential to the economic manufacture of any product, be same large or small, heavy or light, rugged or delicate, and irrespective of purpose or service. This fact has been amply

demonstrated during the past two years. The demand for munitions necessitated the development of certain lines of machinery, to cope with the unprecedented situation created and to solve successfully problems that were entirely new to the metal-working industries of this country. Volumes would be required to relate what has taken place since the inception of shell-making in Canada, but it is safe to say that the knowledge obtained from the participation in the work will fundamentally revolutionize manufacturing methods in many branches of metal-working enterprise. The inability to secure machinery when most needed has probably been the chief reason why so many plants have been forced to make the most use of their available resources, adapting them to achieve what at one time might have been considered impossible. Full scope has been given the inventive genius of those in charge of production, and the resultant fruits have more than met the expectations of the different executives concerned.

of working equipment. This does not mean that a thorough technical knowledge is required, or even desired, by those men employed on the forging process; but each man should so study his particular duties, whether it is heating the billets, cooling the punches, or other apparently insignificant operation, that his eye and his hand shall become so trained, that he will quickly see and readily adapt himself to the needs of the situation, and thus co-operate with his other associates in attaining and

Shell Body Forging

Maximum production of modern munitions of war depend in great measure upon the quality of forgings that are supplied to the manufacturer. In the early period of the war, at a time when little was known regarding the technical or practical side of shell making, the equipment for the purpose was designed more from impromptu need than from any extensive knowledge of previous practice. Experience, however, together with a comprehensive study of the detail requirements has placed the manufacture of shells on a par with other lines of industrial activity, and while the product has varied but little during the past two or three years, the details of production have undergone many changes, with the result that present methods and practice, evolved out of previous faults and failures, have materially reduced the losses incidental to the work.

With due consideration given to the quality of steel used, the successful production of shell forgings is as much a question of trained labor as a problem

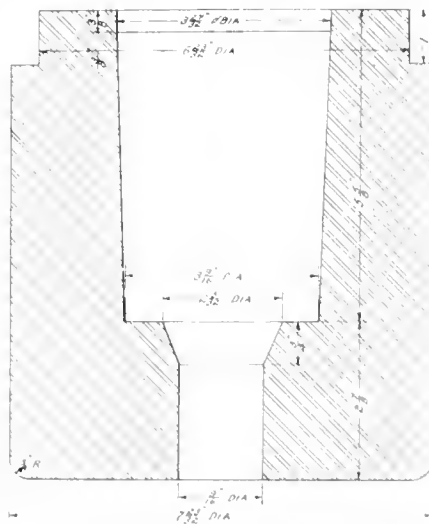
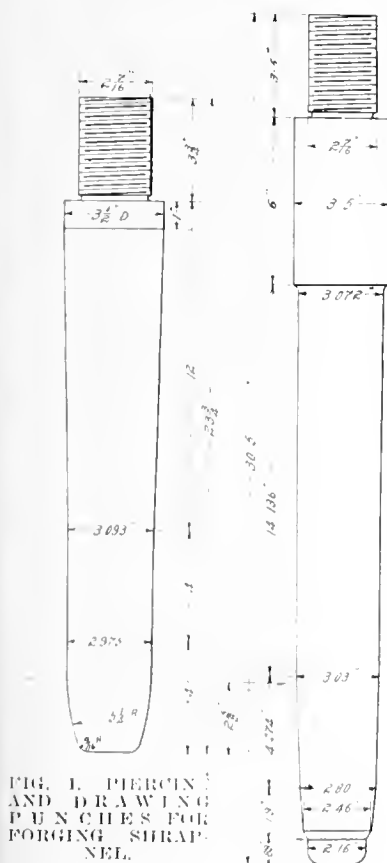

FIG. 2. KNOCK-OFF PROVISION FOR PIERCED BLANK.

maintaining maximum efficiency, both in quality and quantity.

Without actually seeing the process through which the steel passes, in its short but rapid passage from the bar to the rough forging, little conception can be had of the tremendous energy required on the part of the operators, in the performance of their various duties. Every section of the forging department, from cutting-off the billets to the

ly demonstrated during the past two years. The demand for munitions necessitated the development of certain lines of machinery, to cope with the unprecedented situation created and to solve successfully problems that were entirely new to the metal-working in-

stacking of the finished forgings, could be compared to a busy bee colony, where each individual has his allotted

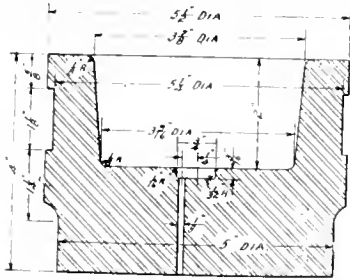

FIG. 3. CUP FORMING DIE WITH TIT.

task to perform, the end being achieved entirely free from disorder or confusion.

The gradual improvement shown in shrapnel shell production in the plant supplying the following data, has resulted from closely studying the varied requirements: and designing the dies and punches to produce a more uniform forging both in shape and dimensions. The cut billets, 5 1/4 inches in length, and 3 1/2 inches in diameter, are placed in several Mechanical Engineering Co. furnaces where they are heated to a temperature of approximately 1800 degs. F. The care exercised at this stage has much to do with the accuracy of subsequent machining operations. The uniform heating of the billets being largely a question of the trained eye, experienced heaters are indispensable, and under no consideration should this work be placed in the hands of a novice.

The first operation on the press is piercing the billet. This is accomplished on a Boomer & Boshert 250 ton hydraulic press fitted with twin dies and punches, so that two shells are operated on at one stroke. In addition to the duplex arrangement, the stroke of the ram has been reduced to eliminate the

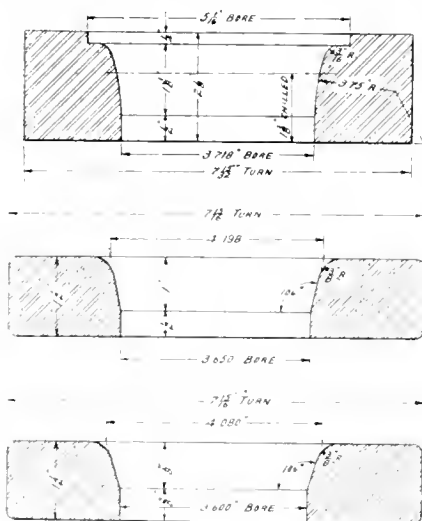

FIG. 4. SERIES OF DRAWING DIES

loss contingent to the unnecessary lift. The actual piercing operation consists of forcing the punch into the billet and causing the metal to flow up and around the punch to a height of about 7 inches,

with a slight taper on the outside surface, the base being 3 9-16 inches diameter, and the upper end 3 27-32 inches.

Punch and Die Features

The piercing punch, shown on the left of Fig. 1, has an overall length of 20 inches from the face of the descending ram. From a tangential point, 2 5/8 inches from the nose, the profile of the punch is formed with a radius of 5 1/4 inches, the extreme nose being rounded to 9-16 inch radius. From the tangential point to a distance 4 inches from the nose, the punch has a parallel diameter of 2.975 inches. With the exception

Fig. 4. The top die is made of cast iron, chilled to height of 1 3/8 inches from the lower surface. The drawing diameter on the upper die is 3.718 inches, and has a parallel length of 1/2 inch, the mouth being belled out with a radius of 3.75 inches. The center die made of machine steel hardened, has a drawing diameter of 3.65 inches, parallel for 1/2 inch, the upper portion having a taper of 14 degrees with the axis of the dies. The lower die has a similar taper but with a parallel portion 5/8 inch long and a diameter of 3.6 inches. The drawing punch shown to the right of Fig. 1 has an overall length of 27 inches, exclusive

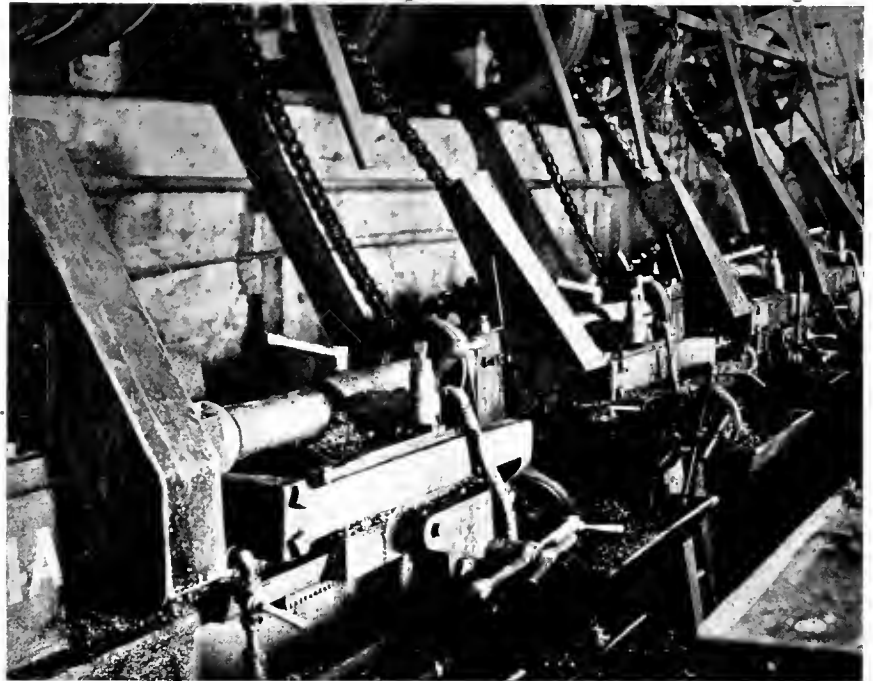

FIG. 5. "LYMBURNER" SPECIAL LATHES ON ROUGH TURNING OPERATION.

of an inch at the upper end, which is parallel, the remainder of the punch has a gradual taper to 3 1/2 inches in diameter, the size 8 inches from the nose being 3.039 inches diameter. As shown in Fig. 2 provision is made for a knockout to eject the pierced blank.

As the blanks lose very little of their heat during this piercing process, they are immediately transferred to the drawing press which is likewise fitted with twin equipment. The first operation is to form the cup recess at the base of the bore. The die shown in Fig. 3 is placed in a recess on the upper surface of the top draw die; when the blanks are placed in this small pot die, the punch descends and forms the rough powder cup chamber. While the general practice is to form the base of these shells flat, a small fit having a diameter of 3/4 inch and a length of 3-16 inch, is often pressed on to reduce the thickness of stock at the base. A small hole is drilled through the die to permit the escape of air.

The ram is again elevated and the blanks placed in the draw dies, when the drawing punch forces the shell completely through the three dies shown in

of the threaded end. This extreme length is necessary in order to force the rough shell completely through the die. As very little machining is done on the upper end of the shrapnel bore, the dimensions of the draw punch should be fairly accurate, with shrinkage allowance. The cup forming tit has a diameter of 2.16 inches, with a corner radius of 1/2 inch and a length of .89 inches; it is flared out to a diameter of 2.46 inches to a point 1.1 inches from the nose. Three sections of varying tapers make up the remainder of the length, the diameters and points of intersection being 2.8 inches at 2.79 inches from the nose; 3.03 inches at 6.864 inches from the nose, and a diameter of 3.073 inches at a point 6 inches from the face of the ram.

After the shells are taken from below the press, they are gauged for concentricity and overall length and then stamped by the inspector, following which they are left to cool preparatory to being machined.

Shell Body Machining

The methods adopted in the plant from which this article has been se-

cured, show clearly to what extent standard machine tool equipment has been eliminated, being replaced by single pur-

operation, the base end of the forging is centered in the lathe, after which the shells are rough turned on the outer dia-

chain drives, and, in order to avoid the necessity of long chains, a special countershaft has been erected about midway between the line shaft and the machines. This additional shaft, which runs continually, is equipped with tight and loose pulleys for each machine, the driving sprocket for the chain belt being rigidly secured to the side of the loose pulley. The chain drive for machines working on operations that require the constant application of oil or cutting lubricant, has an advantage over the leather or cotton belt, inasmuch as the efficiency of the drive is not affected by becoming saturated with the liquid used for lubricating the cutting tools; as a matter of fact, the chain will often do better work when well coated with oil or grease. Owing to the increased hazard contingent to the use of chain belts, special guards are installed upon all machines so equipped, in order to protect the operators. These turning machines

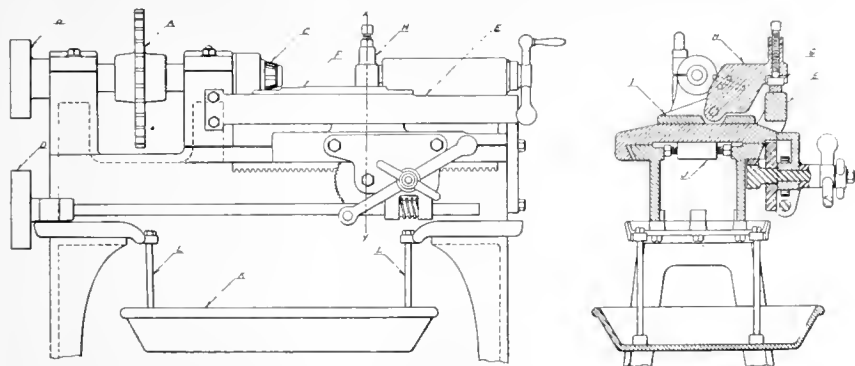

FIG. 6. DETAIL OF SPECIAL ROUGH TURNING LATHES.

pose machines which make for more rapid production of 18-pdr. shrapnel shells. In describing the manufacturing methods of this shop it is not intended to follow in detail the progressive stages, but to dwell more particularly upon those features that have been locally developed and that make for efficiency and maximum output.

Cutting Off and Rough Turning

Cutting off the open end—the first operation—is performed on special machines constructed in the plant. These machines were designed with a view to maximum of efficiency, being equipped with pneumatic chucks and automatic ejectors. The mechanism of the operating arrangement is so constructed as to put a pull upon the piston and connecting rods, this method giving greater satisfaction, as the rods being in tension provide increased holding power to the jaws. After the open end has been cut off and the chuck released, the shell is partly forced out by means of the automatic spring ejector. The length from the inner base to the open end, after cutting off, is 9 inches. Following this

operation, a group being shown in Fig. 5. It will be noted that the general use of belt driven machines has been almost entirely discarded, the majority of the lathes being equipped with Baldwin

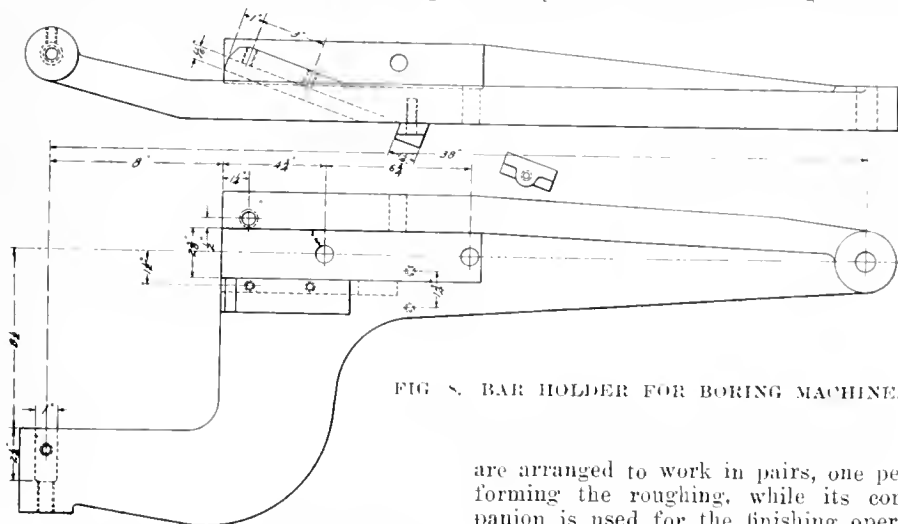

FIG. 8. BAR HOLDER FOR BORING MACHINE.

are arranged to work in pairs, one performing the roughing, while its companion is used for the finishing operation. When roughing the outside, the main portion of the body is turned to a diameter of 3.4 inches, the minimum diameter being .01 inch smaller. One cut is required on each machine, the size of the body and the larger diameter at the mouth being derived by the action of the roeking tool post bracket upon the generating cam which is shown at the front of the lathe, straddling the saddle, and secured to the head-stock at one end, and to the end of the lathe at the other.

Rough Turning Lathe Features

A sketch of these special lathes is shown in Fig. 6, and a casual glance will show the simplicity together with the efficient design for specific operations. The main driving unit or sprocket A is secured to the solid spindle between the two bearings; powerful yet elastic feed drive being obtained by using large diameter and wide face pulleys. Secured to the nose of the spindle is the cone-shaped, inserted serrated tooth driving arbor C. Upon the upper surface of the cam bracket E, which is secured to the stationary parts of the lathe, is the generating cam F, upon which the steel block G bears while the tool is advancing along the shell. The tool block proper is secured to the casting I by means

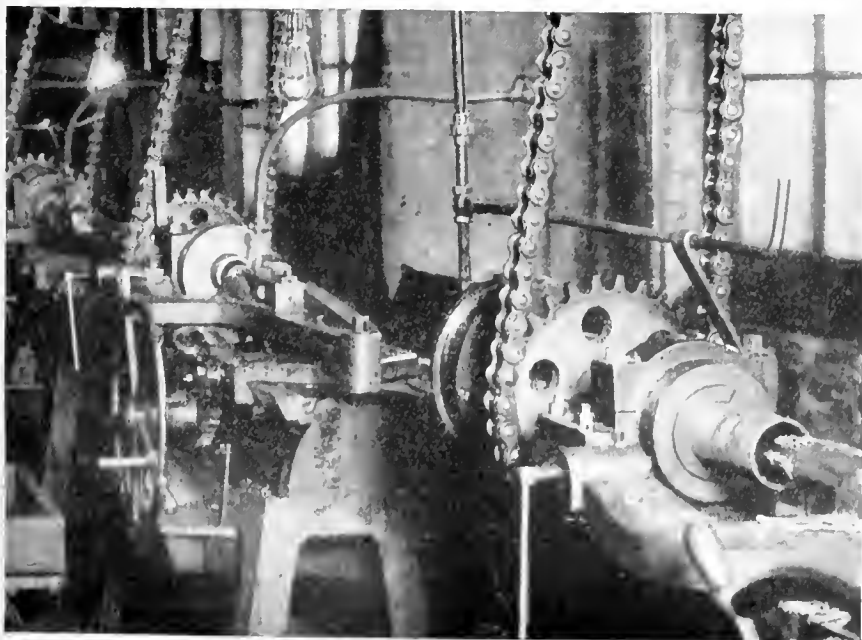

FIG. 7. INTERIOR BORING ON "LYMBURNER" SPECIAL MACHINES EQUIPPED WITH "BALDWIN" CHAIN DRIVE.



FIG. 9. "LYMBURNER" SPECIAL LATHES OPERATING ON WAVES AND GROOVE.

of two trunnions, one on either side. When the tool has been set ready for cutting, close adjustment is obtained by setting the screw in the tool block H. Adjustment of the tailstock is provided for by the lug J, which extends below and between the shears of the lathe. All machines are equipped with drip pans hung below the bed, from which the lubricant is drained to a central well to be again pumped to an overhead supply tank. The dimensions after finish turning are a maximum diameter of 3.32 inches, with a low limit of 3.315 inches. For a distance of $\frac{3}{4}$ inch from the open end, the diameter must be between 3.522 and 3.542 inches; the length of the taper from this point to the body diameter is $1\frac{5}{8}$ inches. The diameter at the base to a point $8\frac{1}{4}$ inches from the open end

has a neutral dimension of 3.308 inches.

Interior Boring

After the base has been rough faced,

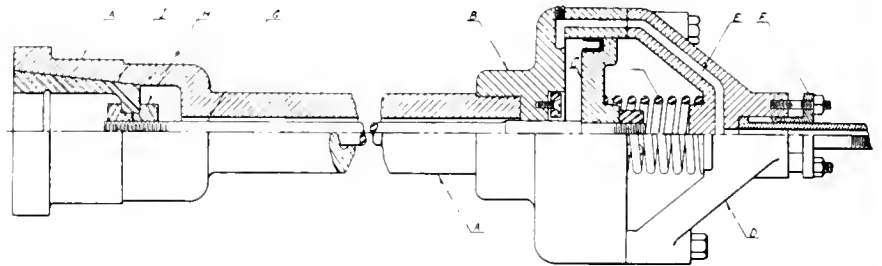

FIG. 10. AIR CHUCK EQUIPMENT OF LATHES.

leaving a maximum thickness of .832 inches, the shells pass to the boring machines for interior machining. These

tools are also of Lymburner make, being specially designed for this operation. As seen in the illustration, Fig. 7, these machines, in common with others, are equipped with chain drive, thus eliminating machine belt slippage and utilizing the full power of the line shaft belting. By referring to Fig. 8, a clearer conception can be had of the operation of the boring bar in developing the inside profile. This large movable arm forms part of the saddle, an extension of which provides a pivot for the rear end, the point being located in a central position at a distance of 38 inches from the generating point of the cam, the latter being secured to front of the forward

a diameter between 2.5975 and 2.6175 inches.

Band Wave and Groove

Before cutting the groove for the copper band, the base is again faced off to the desired thickness, which must not be less than .42 inch. Lymburner special purpose lathes are used for machining the rilling band groove, a cut of one being illustrated in Fig. 9. A fixture, forming part of the lathe, is secured to the forward portion of the head-stock, the waving attachment being in constant motion and forced into the work by the lever at the fore part of the device. The undercutting tools are in operation at the same time, they being used alternately, so that, when the waving is completed, the sides are also finished. A tolerance of .1 inch is permitted on a maximum length of .832 inch from the base to the back edge of the copper band groove.

Heat Treating

Previous to heat treating the shells, several small nicks are made with a cold chisel across the ribs in the band groove, this being considered necessary for the escape of the air from the grooves when the copper is being forced into position. The heat treatment process is similar to that described in former articles, the shells being subjected to a temperature of approximately 1,450 degs. F., care

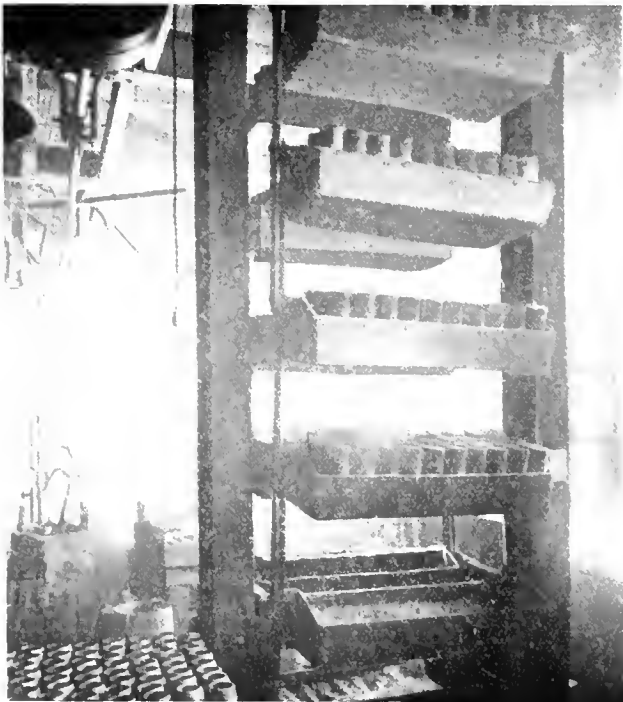

FIG. 11. SPECIAL CONVEYOR IN CONNECTION WITH SHELL NOSE ANNEALING OPERATION.

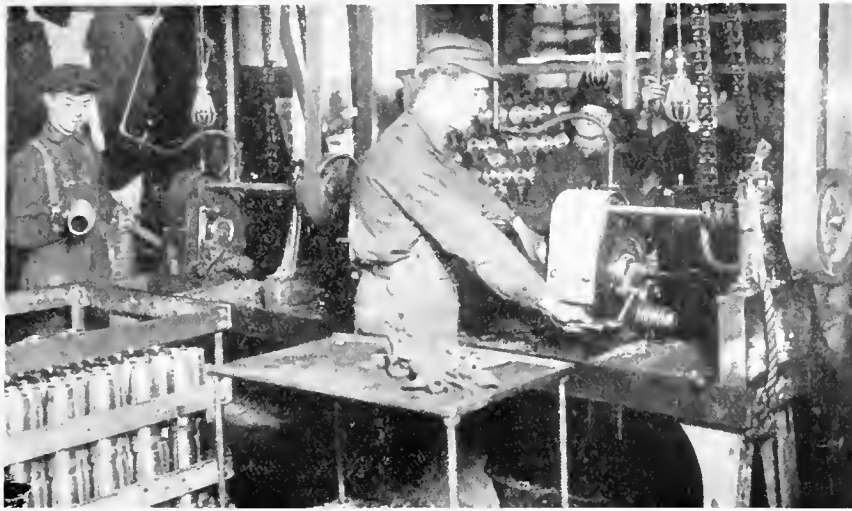

FIG. 12. "LYMBURNER" DOUBLE END CRIMPING MACHINES ROUNDING-OFF CORNERS OF SHELL BASE AND CUTTING SMALL GROOVE JUST BELOW NOSE.

being exercised to obtain an even heat on all portions of the shell. This is essential, as unevenly heated shells when hardened will show various degrees of hardness when tested with the scleroscope,

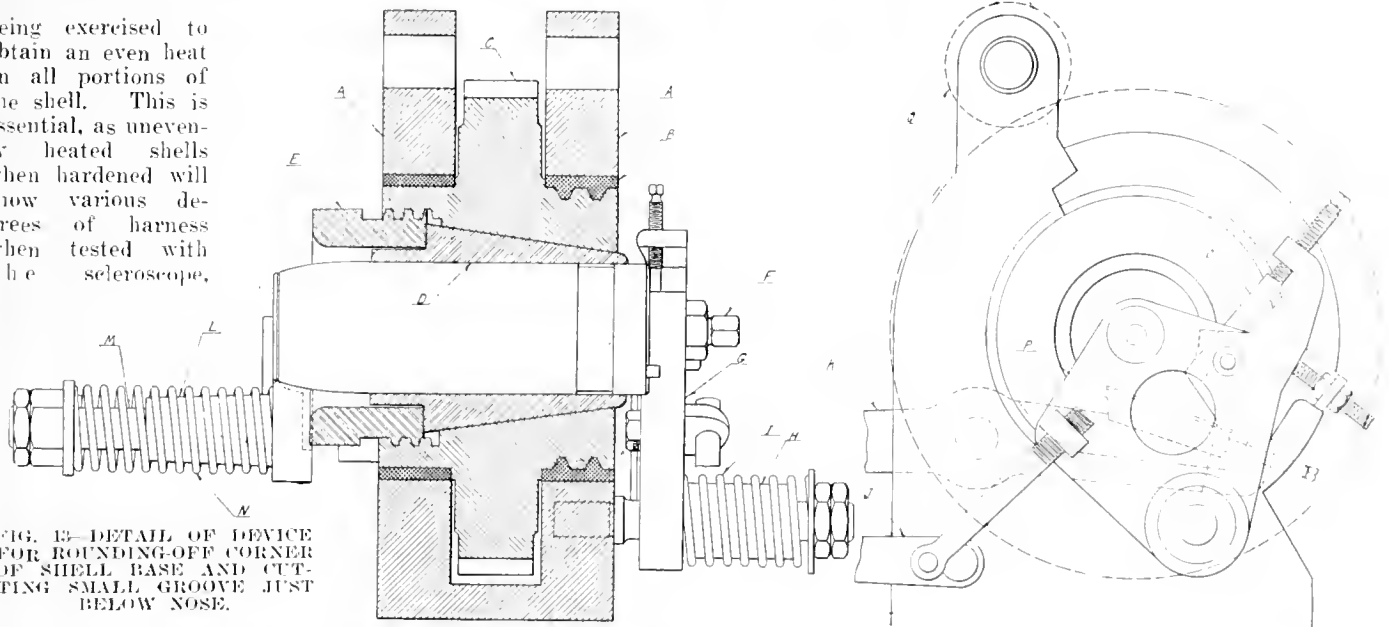

FIG. 13—DETAIL OF DEVICE FOR ROUNDING-OFF CORNER OF SHELL BASE AND CUTTING SMALL GROOVE JUST BELOW NOSE.

which in the case of shrapnel should give a reading of from 45 to 50. If above 50, the shells are again placed in the furnace and drawn back some-

what to reduce the hardness of the metal. The medium for hardening purposes is oil which is contained in a large tank

the scale created by the heating process.

Swedging-in the Nose

Swedging-in the nose is accomplished on a Brown, Boggis geared press; the shells being first heated in a lead bath, for a short distance up, to a temperature of about 1,500 degs. F. The method of heating the nose in the lead bath is necessary in order to localize the heat and avoid drawing the temper from the lower portion of the shell. As the heated shell is being placed in the press, the diaphragm is dropped in, as it is of greater diameter than the bore of the nose.

As the shells come from the swedging press, they are placed in powdered mica, nose downwards, for annealing, as it would be very difficult to machine this portion if shells were allowed to cool in the air. An interesting method has been adopted in this plant for the storage of the shells during the time required for annealing purposes. Adjacent to the nosing press, so as to avoid unnecessary handling, a special conveyor has been erected that not only offers excellent fa-

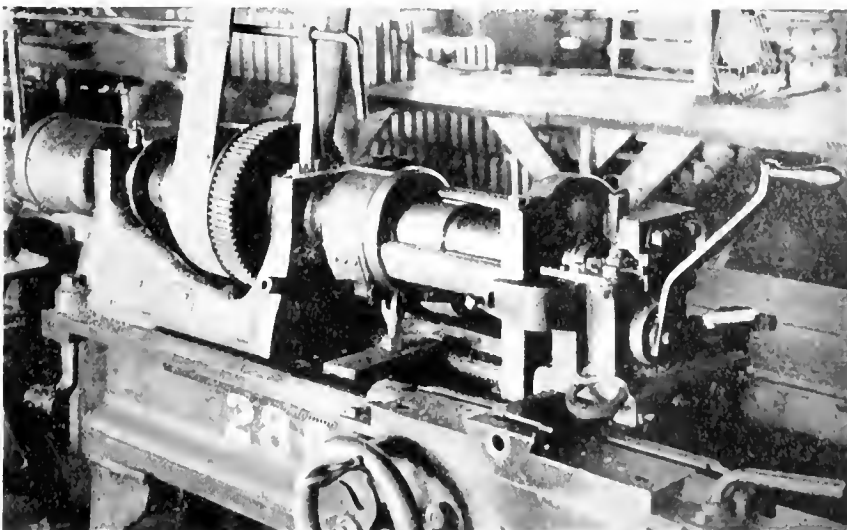

FIG. 14. SPECIAL FIXTURE FOR FINISHING SHRAPNEL SOCKETS.

ilities for annealing the shells, but also solves the problem of additional "floor" space, which is ever an important factor in small shops. To provide ample support for the heavy weight, the structure is strongly built, provision being made for sixteen trays each holding about forty shells each. As each tray is loaded, the conveyor is moved to the next position and, when the conveyor has made one revolution, which takes 4 or 5 hours, the shells are ready to be removed from the trays. A view of this apparatus is shown in Fig. 11. As the shells are taken from the conveyor, they are placed in a small sand blast where the copper band groove is thoroughly cleaned.

Nose Machining

At present the machining of the nose is being accomplished on several Jones & Lamson turret machines, but this operation will soon be performed on special machines now under construction in the shop. The contour of the nose is formed with a radius of 6.57 inches, the tangential point being 1.91 inches back from the open end. After the inner and outer profiles have been finished and the nose threaded, the exterior surface is ground

a thrust bearing. The "spindle" is a large cast iron gear C, which also acts as the outer portion of the chuck. The split collet D that grips the shell is operated by the nut E, the thread of which fits that on the large gear. It is obvious that with this device, it is necessary that the machine be stopped while the shell is being placed in or removed from the chuck; the adjustable stop F, acting as a gauge when placing the shell in position, this bolt passing through the arm G, which also serves as the tool holder for rounding the corner on the base end. To give increased support to this arm, it is provided with an extension H, the whole oscillating on the stud shown, which is serewed to the frame of the machine. As the gauge bolt F is kept in contact with the base of the shell by means of the spring I, any slight variation in the setting of the shell does not affect the operation, as the tool retains its relative position to the gauging point. The operation of this tool arm is obtained by lifting the lever J. Cutting the groove in the nose is similarly achieved, the position of the tool being controlled in a like manner to that on the opposite end. The driving gear ratio

an air vibrator placed immediately beneath the spout of the hopper. This firm is at present using large quantities of these lead bullets, and, in order to conveniently handle same, a special bucket conveyor has been constructed that elevates them from a bin in the basement to the floor upon which they are used. The bullets are discharged into a large hopper above the assembling bench. While the resin is being poured in, the hole in the tube is covered to prevent any of the liquid from entering. When the desired amount has been put in, the brass socket, which has been previously coated with red lead, is serewed into position.

Applying and Machining Nose Sockets

The sockets are serewed into position by means of a mechanical device developed in the shop, a great saving being effected over the hand method. The attachment is secured to the bench so that the shell is held in a vertical position. Before the shell is placed in the chuck, a split bush is dropped over the body to allow for the greater diameter of the copper band, and when the chuck has been tightened by means of a foot treadle, a driving collar is placed on top, which engages with the dogs inserted in the body of the chuck, the fixture being revolved by a worm acting on a gear outside of the central chuck, the latter remaining stationary. As the dogs engage the driving collar, the gripping jaws are forced into the brass socket and turn it to its finished position.

After the sockets are serewed in, and the tube soldered, the shells are taken to the machine shown in Fig. 13 where the brass socket is finish turned. This machine is fitted with a special fixture for holding the shell and machining the same. The shell jig is secured to the face-plate of the lathe and has two stiff arms extending out to a circular portion that revolves in a separate steady rest. The shell is placed in the chuck from the side, between the two arms, and is secured in a working position by the action of an air operated ram forced forward by the cylinder located on the rear of the spindle. The entire machining on the socket is performed by the movement of the handle shown, the outer edge being finished as the lever is pushed outwards, while the reverse movement cuts the inner portion to the desired shape and size.

From here on, the shells are passed through the several operations of reaming and hand sizing, final inspection, painting, packing and shipping. A feature of the plant, and one that has had much to do with the successful production, is the establishment of a local shell committee, which meets periodically to study the best methods of organization for rapid and economic output.

On an examination paper the following question was asked: "What is steam?"

One engineer said: "Steam is water in terrible sweat."

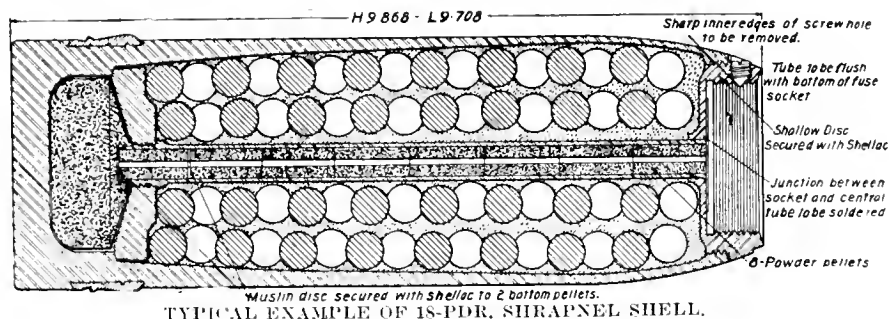

to the final shape and dimensions on a Ford-Smith grinder, several of which are installed for the purpose. After the shells have been subjected to a washing process, which is necessary to remove all grit and grease from the surfaces, the base below the rifling band groove is ground to a maximum diameter of 3.20 inches, with a low limit of 3.283 inches. It might be mentioned here that with a few exceptions, all machines fitted with chucks are equipped with pneumatic devices for more rapid and economic handling of the shells. Fig. 10 is a typical example.

Base Corner Radius

An ingenious device has been designed for rounding off the corner on the base and cutting the small groove just below the nose. Both these operations are performed at the same time, the machine being constructed so that the shell protrudes from both ends of the spindle, which is, generally speaking, simply a revolving chuck. Two of these machines are shown in Fig. 12, and their simplicity is probably one reason of their efficiency. A sectional view of the device is shown in Fig. 13. The frame which is six inches wide, has bearings seven inches in diameter made of babbit metal, one of them so constructed to serve as

is 4 to 1. The groove in the nose is cut to a depth of .0175 inch and a width of .12 inch; the distance from the nose to the edge of the groove should be not greater than .07 inch, and not less than .06 inch.

The next machining operation, that of pressing on and turning the copper band, follows the preliminary inspection. Pressing on the copper band is accomplished on a 150-ton Lymburner hydraulic press, operating at a pressure of 1,500 lbs. per square inch. In order to avoid any possibility of over compression on the shell, the press is fitted with a safety relief valve located on the supply pipe. Special lathes fitted with Lymburner improved band turning attachment, are provided for machining the copper bands.

Shell Assembly

Body machining is now completed and the shells are ready for assembling. The tin powder cups are first placed in, and allowed to drop below the diaphragm, after which the brass tubes are serewed into the diaphragm and the surrounding space filled with lead bullets. In order to get the required number of bullets in the shell, it is necessary to jar the latter, this being accomplished by means of

The MacLean Publishing Company

LIMITED

(ESTABLISHED 1888)

JOHN BAYNE MACLEAN President
 H. T. HUNTER Vice-President
 H. V. TYRRELL General Manager

PUBLISHERS OF

CANADIAN MACHINERY AND MANUFACTURING NEWS

A weekly newspaper devoted to the machinery and manufacturing interests.

PETER BAIN, M.E., Editor. B. G. NEWTON, Manager.

Associate Editors.

A. G. WEBSTER, J. M. WILSON, J. H. RODGERS.

Office of Publication, 143-153 University Avenue, Toronto, Ont.

Vol. XVII. MARCH 8, 1917 No 10.

OUR PRESENT EFFORTS A FUTURE ASSET

HISTORY has been made in more ways than by feats of arms since the memorable appeal for shells was made by Sir John French when in command of the British forces in France. Not the least notable of developments incident to the then crisis has been the steady increase of munitions output by Canada, with its resulting influence on our future status in the manufacturing world, and which, is yet, possible of little more than approximate estimation. One fact, however, stands out in strong relief amid the meantime din of industrial effort, viz., our reserve strength in men, money and material wealth.

In pre-war days the productive capacity of the Dominion, in strictly mechanical fields, was of a very limited nature, due in part to the fiscal policy which seems to be indispensable to young industrial nations during the embryonic stages of developing their natural resources and consolidating their commercial and manufacturing enterprises. Had times such as these been foretold in all their present reality, their improbability would have been readily admitted rather than otherwise.

In referring to the articles on munitions manufacture which feature this issue, it may be said that they in themselves are ample evidence of the first item of reserve strength, i.e., men. The use of the word "men" is, of course, somewhat ambiguous now, in view of the successful and increasing employment of women, and when we say successful, we mean more than getting out shells or fuses on time. By successful, we mean the utilization of women help in such a manner that mutual satisfaction with the results obtained will insure a future continuance whenever and wherever opportunity offers. Among the contributing factors may be mentioned equitable remuneration, facilities enabling their arrival and departure from work to be made in a manner consistent with reasonably refined custom, and the shortest hours possible that the nature of the work permits.

Another noteworthy and intensely personal factor, and perhaps more important than that of actual service, is the mechanical resourcefulness which has been displayed by the staffs of hundreds of factories from ocean

to ocean. In the ordinary course of events, thousands of mechanics would never have had occasion to worry about methods and devices of production to the extent at least that these latter have had to be applied in solving satisfactorily munitions manufacturing problems. Their experience with products of their own brains and hands in competition with those of erstwhile competitors and foreign specialists has given them a confidence in their own ability and a capacity for estimating and appreciating at their true value the products of others, a circumstance in itself that cannot help but have a great, though indirect bearing on our future industrial activities.

It has enabled them and others to judge our engineering products from every angle, and, while the ultimate growth of the country precludes the possibility of being entirely independent of foreign machine tool builders, conditions during the last two years have been such that a fuller, stronger, wider, and more distinctively Canadian industry in machine tool building can be confidently looked forward to.

Vast though our expenditure on war has been, it must not be forgotten that our ability to meet this is due to national credit, which in turn is founded on national resources. Without the first and last of these—men and materials—our credit might long ago have ceased to exist. The recognition by the Government of the necessity for scientific research, and subsequent industrial development, will result in an ever-increasing appreciation of Canada's natural wealth. The extent of our dependence on the United States for essential materials would be brought home to us, perhaps more vividly, if the entrance of that nation into the European conflict resulted in prohibition or even restriction of much meantime exported material. It would, however, be ultimately beneficial so far as it stimulated the development of our own resources—mineral and manufacturing, and many present projects in these directions, especially the latter, are not likely to be abandoned without a struggle.



DEVELOPMENT OF SHIPBUILDING AND MARINE ENGINEERING

REGARDING the plans of the Imperial authorities relative to the development in Canada of shipbuilding and marine engineering, together with the auxiliary equipment incidental and necessary thereto, we are in a position to state that in at least one instance definite arrangements have now been concluded, and contracts arising therefrom placed. Immediate action is being taken regarding fulfillment of the latter. Reference was here made in our last week's issue to the fact that negotiations concerning the above had been entered upon and were making progress.

Shipbuilding and marine engineering combine an aggregation of manufacturing industries in their finished product unsurpassed by any other forms of industrial endeavor, and what is thus true in a general sense, is even more emphatically so as regards iron, steel, and the manufactures thereof. The plans now being matured will include in their scope not only our at present established ship and marine engine builders, but the establishment of others of a like nature in combination or separate. In addition, those of our engineering plants in position to undertake the building of marine boilers, propelling and auxiliary machinery—the latter ship deck or 'tween decks—are embraced in the projected developments referred to.

Taken all in all, no such opportunity has ever presented itself to Canadian business enterprise as that of shipbuilding in its variety scope, now knocking, and no such urgency either for the "Cause" or otherwise, has been so worthy of prompt consideration.

SELECTED MARKET QUOTATIONS

Being a record of prices current on raw and finished material entering into the manufacture of mechanical and general engineering products.

PIG IRON.

Grey forge, Pittsburgh...	\$31 95
Lake Superior, charcoal, Chicago	35 75
Standard low phos., Philadelphia	56 00
Bessemer, Pittsburgh	35 95
Basic, Valley furnace	30 00
Montreal Toronto	
Middlesboro, No. 3	
Cleveland, No. 3	
Clarence, No. 3	
Hamilton	
Victoria	

FINISHED IRON AND STEEL.

Per lb. to Large Buyers Cents	
Iron bars, base, Toronto	4 00
Steel bars, base, Toronto	4 25
Steel bars, 2 in. to 4 in. base	5 25
Steel bars, 4 in. and larger base	6 50
Iron bars, base, Montreal	3 95
Steel bars, base, Montreal	4 10
Reinforcing bars, base	4 05
Bessemer rails, heavy, at mill	
Steel bars, Pittsburgh	
Tank plates, Pittsburgh	
Beams and angles, Pittsburgh	
Steel hoops, Pittsburgh	
F.O.B. Toronto Warehouse.	
Steel bars, base	4 25
Small shapes	4 75
F.O.B. Chicago Warehouse	
Steel bars	3 90
Bars, 2 in. and up	4 40
Structural shapes	4 00
Plates	4 75

FREIGHT RATES.

Pittsburgh to Following Points	
Per 100 lbs.	
C.L.	L.C.L.
Montreal	23.1 31.5
St. John, N.B.	35.1 45.5
Halifax	35.1 45.5
Toronto	18.9 22.1
Guelph	18.9 22.1
London	18.9 22.1
Windsor	18.9 22.1
Winnipeg	64.9 85.1

METALS.

Montreal Toronto	
Lake copper	\$42 00 \$39 00
Electro copper	42 00 39 00
Castings, copper	41 00 39 00
Tin	53 50 56 00
Spelter	15 00 14 00
Lead	13 00 12 50
Antimony	34 00 35 00
Aluminum	70 00 68 00

Prices per 100 lbs.

BOILER PLATES.

Montreal Toronto	
Plates, 1/2 to 1 1/2	\$6 50 \$6 50
Heads	6 85 6 85
Tank plates, 2-16 in.	6 10 6 10

WROUGHT PIPE.

Prices in effect Feb. 14, 1917.	
Per 100 feet—Black Galv.	
Butt-weld.	
1/4 in.	\$ 4 50 \$ 6 00
1/2 in.	3 66 5 79
3/8 in.	3 66 5 79
1/2 in.	4 76 6 23
3/4 in.	5 87 7 89
1 in.	8 67 11 82
1 1/4 in.	11 73 15 99
1 1/2 in.	14 03 19 11
2 in.	18 87 25 72
2 1/2 in.	29 84 40 66
3 in.	39 02 53 17
3 1/2 in.	48 76 65 78
4 in.	57 77 77 94
Lap-weld.	
2 in.	21 83 28 31
2 1/2 in.	32 76 43 00
3 in.	43 21 56 00

3 1/2 in.	53 36 70 28
4 in.	63 22 83 39
4 1/2 in.	73 66 97 16
5 in.	85 84 113 20
6 in.	111 40 146 90
7 in.	147 00 191 60
8 in. L.	155 00 201 30
8 in.	178 00 231 80
9 in.	213 90 277 70
10 in. L.	198 40 257 60
10 in.	255 40 331 70

Prices Ontario, Quebec and Maritime Provinces.

WROUGHT NIPPLES.

4" and under, 60%.
4 1/2" and larger, 55%.
4" and under, running thread, 40%.
Standard couplings, 4" and under, 50%.
4 1/2" and larger, 30%.

OLD MATERIAL.

Dealers' Buying prices.	
Montreal Toronto	
Copper, light	\$23 00 \$24 00
Copper, crucible	27 00 28 00
Copper, heavy	27 00 24 50
Copper wire	27 00 25 00
No. 1 machine composition	23 00 22 00
No. 1 composition turnings	19 00 20 00
New Brass clippings	18 00 18 00
No. 1 brass turnings	15 00 16 00
Steel, low phos.	14 00 18 00
Heavy Melting steel	13 00 15 00
No. 1 machine cast iron	21 00 16 00
Steel turnings	9 00 9 00
Boiler plate	12 00 10 50
Rails	14 75 15 00
Axles, wrought iron	19 00 24 00
Tires, steel	12 00 12 00
Rails	13 75 14 00
Shafting	21 00 20 00
Malleable scrap	10 25 11 00
Pipe, wrought	10 50 9 00
Stove plate	14 00 13 00
Heavy lead	8 00 8 50
Tea lead	6 00 6 50
Scrap zinc	8 50 9 50
Aluminum	36 00 35 00

BOLTS, NUTS AND SCREWS.

Per Cent.	
Coach and lag screws	30
Stove bolts	55
Plate washers	10
Machine bolts, 7-16 and over	10
Machine bolts, 3/8 and less	20
Blank bolts	10
Bolt ends	10
Machine screws, fl. and rd. hd., steel	27 1/2
Machine screws, o. and fl. hd., steel	10
Machine screws, fl. and rd. hd., brass	add 20
Machine screws, o. and fl. hd., brass	add 25
Nuts, square, up to 1 in., net list.	
Nuts, hex., up to 1 in., net list.	
Copper rivets and burrs, list plus	30
Burrs only list plus	50
Iron rivets and burrs	27 1/2
Boiler rivets, base 3/4-in. and larger	\$6.35
Structural rivets, as above	6.25
Wood screws, flat, bright	.75
Wood screws, O. & R., bright	.70
Wood screws, flat, brass	.42 1/2
Wood screws, O. & R., brass	40
Wood Screws, flat, bronze	35
Wood screws, O. & R., bronze	22 1/2

MILLED PRODUCTS.

Per cent.	
Set screws	35
Sq. & Hex. Head Cap Screws	30
Rd. & Fil Head Cap Screws	30
Flat & But. Hd. Cap Screws	10
Pin. & Semi-fin. nuts up to 1 in.	35
Pin. and semi-fin. nuts, over 1 in., up to 1 1/2 in.	30
Pin. and semi-fin. nuts, over 1 1/2 in., up to 2 in.	20
Studs	10
Taper pins	19
Coupling bolts, plus	40
Planer head bolts, without fillet	10
Planer head bolts, with fillet	10 and 10
Planer head bolt nuts, same as finished nuts.	
Planer bolt washers	net
Hollow set screws, list plus	20
Collar screws, list plus	30, 10
Thumb screws	20
Thumb nuts	65
Patch bolts, add	40, 10
Cold pressed nuts to 1 1/2 in.	add \$1.50
Cold pressed nuts over 1 1/2 in.	add \$7.00

BILLETS.

Per gross ton	
Bessemer billets	\$65 00
Open-hearth billets	65 00
O.H. sheet bars	65 00
Forging billets	90 00
Wire rods	80 00
F.o.b. Pittsburgh.	

NAILS AND SPIKES.

Wire nails	5 00 4 95
Cut nails	4 70 4 70
Miscellaneous wire nails	65%
Pressed spikes, 3/8 diam., 100 lbs.	4 60

MISCELLANEOUS.

Solder, strictly	0 33
Solder, guaranteed	0 35
Babbitt metals	13 to 60
Soldering coppers, lb.	0 53
Putty, 100-lb. drums	3 85
White lead, pure, cwt.	14 25
Red dry lead, 100-lb. kegs, per cwt.	13 87
Glue, French medal, lb.	0 25
Tarred slaters' paper, roll	0 95
Gasoline, per gal., bulk	0 20 1/2
Benzine, per gal., bulk	0 29 1/2
Pure turpentine, single bbls., gal.	0 71
Linseed oil, raw, single, bbls.	1 43
Linseed oil, boiled, single bbls.	1 43
Plaster of Paris, per bbl.	2 50
Plumbers' oakum, per cwt.	8 00
Packing, square braided	0 27
Packing, No. 1 Italian	0 32
Packing, No. 2 Italian	0 25
Lead wool, per lb.	0 15
Pure Manila rope	0 29 1/2
Transmission rope, Manila	0 37 1/2
Drilling cables, Manila	0 32 1/2

POLISHED DRILL ROD.

Discount off list, Montreal and Toronto	25%
---	-----

CARBON DRILLS AND REAMERS.

Per Cent.	
S.S. drills, wire sizes up to 5/2	40
S.S. drills, wire sizes, No. 53 to 80	25
Standard drills to 1 1/2 in.	40
Standard drills, over 1 1/2 in.	15
3-fluted drills, plus	10
Jobbers' and letter sizes	40
Bit stock	40
Ratchet drills	15
S.S. drills for wood	40
Wood boring brace drills	25
Electricians' bits	30
Sockets	30

Sleeves	40
Tapper pin reamers	20
Drills and countersinks	list plus 30
Bridge reamers	45
Centre reamers	10
Chucking reamers	10
Hand reamers	15

COLD ROLLED SHAFING.

At mill	list plus 40%
At warehouse	list plus 50%
Discounts off new list. Warehouse price at Montreal and Toronto.	

IRON PIPE FITTINGS.

Canadian malleable, A, add 10%; B and C, 10%; cast iron, 35%; standard bittings, 50%; headers, 60; flanged unions, 40; malleable bushings, 50; nipples, 55; malleable lipped unions, 50.
--

SHEETS.

Montreal Toronto	
Sheets, Black, No. 28	\$5 50 \$6 15
Sheets, Black, No. 10	6 00 6 00
Canada plates, dull, 52 sheets	5 75 5 75
Canada plates, all bright	7 50 7 50
Apollo brand, 10% oz. galvanized	7 25 7 25
Queen's Head, 28 B. W.G.	7 70 7 75
Flour-de-Lis, 28 B.W.	
G.	7 45 7 25
Corbal's Best, No. 28	8 25 7 70
Corborne Crown, No. 28	8 00 6 75
Premier, No. 28 U.S.	7 75 7 70
Premier, 10 3/4 oz.	8 00 8 60

PROOF COIL CHAIN.

1/4 in.	\$9 45
5-16 in.	9 10
3/8 in.	8 85
7-16 in.	7 15
1/2 in.	6 95
9-16 in.	6 85
5/8 in.	6 50
3/4 in.	6 70
7/8 in.	6 55
1 inch	6 40

Above quotations are per cwt.

ELECTRIC WELD COIL CHAIN B.B.

1/8 in.	\$15 50
3-16 in.	11 70
1/4 in.	8 40
5-16 in.	7 40
3/8 in.	6 35
7-16 in.	6 35
1/2 in.	6 35
5/8 in.	6 35
3/4 in.	6 35

Prices per 100 lbs.

FILES AND RASPS.

Per Cent.	
Great Western, American	60
Kearney & Foot, Arcade	60
J. Barton Smith, Eagle	60
McClelland, Globe	60
Whitman & Barnes	60
Black Diamond	50
Delta Files	47 1/2
Nicholson	50
Globe	57 1/2
Vulcan	57 1/2
Disston	60

COAL AND COKE.

Solvay Foundry Coke	
Connellsville Foundry Coke	
Yough Steam Lump Coal	8 50
Pittsburgh Steam Lump Coal	8 50
Best Slack	9 00

Net ton f.o.b. Toronto

BOILER TUBES.			TAPES.		ANODES.		SHEETS, 3½ lb. sq. ft.	
Size.	Seamless	Lap-welded	Chesterman Metallic, 50 ft.	\$2 00	Nickel	.50 to .54	16 00	16 00
1 in.	\$22 00	Lnkin Metallic, 603, 50 ft.	2 00	Cobalt	1.75 to 2.00	15 50	15 50
1¼ in.	25 00	Admiral Steel Tape, 50 ft.	2 75	Copper	.44 to .46
1½ in.	29 00	21 00	Admiral Steel Tape, 100 ft.	4 45	Tin	.49 to .56
1¾ in.	30 00	22 50	Major Jun. Steel Tape, 50 ft.	3 56	Zinc	.23 to .25
2 in.	33 00	23 00	Rival Steel Tape, 50 ft.	2 75	Prices Per Lb.			
2½ in.	35 50	29 50	Rival Steel Tape, 100 ft.	4 45	COPPER SHEETS.			
3 in.	46 00	34 50	Reliable Jun. Steel Tape, 50 ft.	3 50	Montreal Toronto			
3¼ in.	41 00	Bars, ½ to 2 in.	\$46 00	\$46 00
3½ in.	53 00	44 00	WASTE.		Plain sheets, 14 oz.
4 in.	65 00	55 00	White Cents per lb.		14x28 in., 14x60 m	45 00	45 00
Prices per 100 feet, Montreal and Toronto.			XXX Extra	20	Copper sheet, tin-
OILS AND COMPOUNDS.			Peerless	20	ned, 14x60, 14 oz.	54 00	54 00
Castor oil, per lb.	25	Grand	19	Copper sheet, plain-
Royalite, per gal., bulk	15	Superior	19	ished, 14x60 base.	57 00	57 00
Machine oil, per gal.	25½	X L C R	18	Braziers' in sheets.
Black oil, per gal.	12½	Atlas	18	6x4 base	46 50	46 50
Cylinder oil, Capital	45½	X Empire	18	BRASS.			
Cylinder oil, Acme	36½	Ideal	17	Brass rods, base ½ in to 1
Standard cutting compound, per lb.	0 6	X press	16	in rd.	0 55
Lard oil, per gal.	1 45	COLORED.		Brass sheets, 8 in. wide, 20 oz.	0 40
Union thread cutting oil antiseptic	68	Lion	11½	Brass tubing, seamless	0 55
Acme cutting oil, antiseptic	37½	Standard	13	Copper tubing, seamless	0 35
Imperial quenching oil	39½	No. 1	13	PLATING SUPPLIES.			
Petroleum fuel oil	12	Popular	11½	Polishing wheels, felt.	2 10
BELTING—NO. 1 OAK TANNED.			Keen	10½	Polishing wheels, bull-neck	1 35
Extra heavy, single and double	30-5%	WOOL PACKING.		Emery in kegs, American	06
Standard	40%	Arrow	25	Pumice, ground	04
Cut leather lacing, No.1	1 50	Axle	20	Emery glue	15 to 20
Leather in sides	1 35	Anvil	15	Tripoli composition	04 to 06
			Anchor	11	Crocus composition	07 to 08
			WASHED WIPERS.		Emery composition	08 to 09
			Select White	12	Rouge, silver	35 to 50
			Mixed colored	10	Rouge, powder	30 to 35
			Dark colored	09	Prices Per Lb.			
			This list subject to trade discount for quantity.		LEAD SHEETS.			
			RUBBER BELTING.		Montreal Toronto			
			Standard	50%	Sheets, 3 lbs. sq. ft.	\$16 00	\$16 00
			Best grades	50%	Prices Per Lb. Unless Otherwise Stated.			

The General Market Condition and Tendency

THE industrial situation continues satisfactory in regard to the volume of business offering, but manufacturers are still experiencing the greatest difficulty in getting supplies of raw material, owing to the freight congestion on the railways. The shortage of coal has been relieved, but the railways so far have been unable to do much in the way of moving the large volume of freight lying in the yards at the frontier. The situation is serious and is affecting trade generally, touching both manufacturers and merchants. Receipts of coke and pig-iron at the furnaces are improving, and it is expected that the output of domestic pig-iron will increase materially in the near future. There is, however, no Canadian foundry pig-iron on the market at the present time. The situation at the foundries has improved to some extent, owing to increase in supply of raw materials. Prices of steel products continue very firm, and the general impression is that further advances are certain, notwithstanding the prevailing high level of values. This will naturally be reflected in prices of finished iron and steel goods, and, therefore, affecting many lines of machine shop supplies. While the machine tool market is not particularly active just now, business is a little better than it was earlier in the year. Canadian machine tool builders have, however, plenty of work on hand, with deliveries, if anything, rather slow. Prices are very firm and further advances on some lines of tools are anticipated. Quotations on all kinds of scrap metals are very firm, with an upward trend. The ingot metal markets continue very firm, influenced largely by the expectation of war between the United States and Germany, in which event prices would undoubtedly advance materially.

Montreal, Que., March 5. —The industrial situation has undergone little change during the week. The freight congestion is not so pronounced, but conditions as yet show little relief. The lack of fuel and other raw materials is still a feature of the situation, and no immediate relief is anticipated. Developments

in the States may terminate in a crisis at any time, and predictions of daily conditions are more or less futile.

Pig Iron

That the steel situation is due for further strength is indicated in the recent sharp advance in the pig iron market.

The scarcity of raw material, coupled with heavy demands, has been followed by an advance ranging from \$1 to \$6 per ton for various grades of American iron. Canadian producers are out of the market, having withdrawn all price quotations.

Steel

The railroad situation has experienced some relief during the week, but facilities as yet are far from adequate. Many factories are still affected by shortage of raw materials and maximum activities have not yet been generally resumed. Steel dealers locally report the conditions as increasingly serious, and anticipate still further difficulties should the States reach the breaking point with Germany. The Pittsburg quotation on billets has been advanced \$5 per ton, the nominal figure being now \$70. Forging billets show a similar increase, the quotation being \$90 per ton. The shortage in plates is still acute, and mills are reported to be filled up until the close of the year. Higher prices are looked for in sheets. Indications point to an advance in wire products very shortly, as several producers have already withdrawn quotations, pending a readjustment. Owing to prevailing conditions, this will not come as a surprise, as this line has remained steady for some time, under adverse circumstances. Following increased demand for iron bars, the price on this commodity has been advanced \$5 per ton. The local situation is practically unchanged, but dealers anticipate a tighter situation in the near future. Price changes are confined to boiler plates, these being advanced \$10 per ton, the current nominal quotation

being \$6.50 for $\frac{1}{4}$ to $\frac{1}{2}$ -inch plates, and \$6.85 for heads.

Metals

Existing conditions all tend to increase the strength of the metal situation. The movement is generally upwards, emphasized by inability to secure delivery. Copper is very strong, but not active. Tin has again reacted upwards. Spelter is steady, but with a weaker undertone. Lead is again advancing. Antimony is firm, but developing weakness.

Copper.—The market is still influenced by the continued upward movement of prices, and buying is light. Uncertainty on all sides as to the early future seems to have developed extreme cautiousness on the part of consumers and sales are generally being made only for immediate needs. The London market is very firm, but the nominal price on the New York market has declined $\frac{1}{2}$ c on the week, the current quotation being 36 $\frac{1}{2}$ c for electrolytic and 33 $\frac{1}{2}$ c for castings. Dealers here have advanced quotations 2c per lb., lake and electrolytic being 42c and castings 41c.

Tin.—While little tonnage of tin has been lost through submarine activity, the possibility is ever present, and the market is in a state of continual expectancy. Both London and New York are quoted at higher levels, the latter reporting the quotation of 53c, this being 3 $\frac{1}{2}$ c higher than last week. Tin has again advanced locally, the quotation being 53 $\frac{1}{2}$ c, an advance of $\frac{1}{2}$ c per lb.

Spelter.—Operations on the part of dealers have developed a firmer tone, but consumers have not been influenced to take an active interest in the present situation. Producers were looking forward to a return of former activity, and should this situation continue, spelter may show a weaker tendency. The American situation is very firm, with prices $\frac{1}{2}$ c above that of last week, the New York quotation being 11c per lb. Local dealers report an easier tendency, but prices firm at 15c per lb.

Lead.—Some relief has been given to the situation by the easing of the freight situation, but the scarcity of spot metal is apparently as pronounced as ever. The action of the trust in advancing their quotation to 9c has placed lead in a much stronger position. Dealers here report an advance of $\frac{1}{2}$ c on a strong market, the quotation being 13c per lb.

Antimony.—Improved transportation facilities have enabled deliveries to be made to an extent which has brought about a slight weakening in demand, with prices dropped somewhat. A decline of 3c on New York quotations has reduced the nominal price to 31c per lb. Firm locally at 34c per lb.

Aluminum.—The situation is very firm, the market showing an undertone of strength. Unchanged here at 70c per lb.

Machine Tools and Supplies

No features have developed to change the general situation, although the trade anticipates conditions in the near future that may materially affect the present tone of the situation. The serious effect

that the stoppage of American shell contracts was expected to have on the Canadian situation, owing to the fact that much of the machinery would be placed here, has quieted down, and the prospect now is that very little of this equipment will find its way to Canada, as America may find itself in a position to utilize the bulk of this shell machinery. While the present business is not heavy, the outlook for the spring months is encouraging, in view of further prospective shell contracts. Sales of machinery are confined to single or small lots, and delivery on these is still delayed by existing railroad conditions.

Scrap

Increasing strength is developing in the scrap situation, and higher prices are pending. New York quotations are generally stronger, and dealers here are contemplating a readjustment. The transportation question is still serious, and difficulty is experienced in receiving and making shipments. Local changes are confined to machine compositions and turnings, the former being quoted at 23c and the latter at 19c per lb., this being an advance of 1c and $\frac{1}{2}$ c respectively.

CANADIAN GOVERNMENT PURCHASING COMMISSION

The following gentlemen constitute the Commission appointed to make all purchases under the Dominion \$100,000,000 war appropriation:—George F. Galt, Winnipeg; Hormidas Laporte, Montreal; A. E. Kemp, Toronto. Thomas Hilliard is secretary, and the Commission headquarters are at Ottawa.

Toronto, Ont., March 6.—While the fuel situation has been relieved for the time being, little improvement has been noticeable as regards supplies of raw materials. The efforts of the railways were concentrated on moving coal but there still remains a large volume of freight along the frontier that has not been touched. Manufacturers who cannot get their raw materials are seriously handicapped. Machinery houses have the greatest difficulty in getting shipments through, while several cars of steel products have been over three months in transit from Pittsburgh to Toronto.

Steel

The situation in the steel trade has improved during the past week principally because supplies of coke are coming forward in greater volume. It will probably be some weeks before conditions are really satisfactory and production of steel reaches the level which obtained during the latter part of 1916. The return of cold weather will further handicap the railways and cut down supplies of fuel. Notwithstanding adverse conditions however, the steel companies are making a fine showing

in regard to the production of steel for munitions. Plant extensions have of course enabled them to increase their output, to mention one concern only as a typical case. The Nova Scotia Steel & Coal Co., whose report for 1916 was recently issued. The output of forged shells in 1916 was 90 per cent. greater in number, and 120 per cent. greater in weight than in the previous year, while the total shipments of finished steel, forgings, etc. showed an increase of as much as 64 per cent.

Prices of iron and steel products continue very firm and further advances in the near future are expected. Plates, particularly, are bound to reach considerably higher levels owing to the large excess of demand over production. The mills are declining large tonnages because their capacity is quite unable to cope with the extraordinary heavy demand. The urgent demand for ships is the principal reason for the unusually tight situation in plates. Higher prices on wrought pipe are likely as skelp has recently advanced. Steel bars and shapes are unchanged, but very firm. A shortage of natural gas at Hamilton is causing considerable inconvenience at the mills.

Sheet mills continue to operate at reduced output, production ranging from about 75 to 85 per cent. of capacity owing to the unsatisfactory traffic conditions. Shut-downs are threatening all the time owing to the shortage and uncertainty of supplies of raw materials, chemicals, and fuel. Practically all mills are sold up for most of their first and second quarter output, prices are thus very firm and seem certain to advance. Galvanized sheets are already up; Premier No. 28 gauge is quoted at \$7.70, and 10 $\frac{3}{4}$ oz. at \$8.00 per 100 lbs., with higher prices expected.

The fuel situation in the United States is not quite so acute but is still seriously affecting production at a time when even a small falling off in output is severely felt. During February, operations at the mills equalled only 70 per cent. capacity, the falling-off in production being due to the severe cold weather and transportation difficulties. The situation has recently improved to some extent, production now being about 85 per cent. of capacity. Prices of iron and steel products continue very firm, but no important changes have been made during the week.

Pig Iron

With the freight situation improving, shipments of coke and pig iron are moving more freely. If the improvement continues with no set-back, the furnaces and foundries in this district will resume more active operations. The pig iron market is still very firm and prices steadily advancing. Very little foundry iron has been obtainable from Buffalo furnaces, but what can be secured is around \$37 at furnace.

Scrap

The improvement in the freight situation (Con. on page 155, Advtg. Section.)

TORONTO MARKETS—Continued.

tion is welcomed by scrap dealers and business is more active. Prices continue very firm on all kinds of old material, but there are no important changes to note. There is a heavier demand for low phosphorus steel scrap, and prices are steadily stiffening. Lead scrap is very firm and an advance is looked for shortly. All grades of copper and brass scrap continue very firm at unchanged prices.

Machine Tools

The machine tool market continues fairly quiet, the general disposition being to await developments as regards further shell contracts. The business that is passing is almost entirely in connection with munitions plants. Deliveries are slow on practically all lines of machine tools with the exception of lathes which are readily obtainable. Second-hand equipment is in good supply, but the demand is light at present. Prices continue to have an upward tendency. Some firms are only quoting at the price obtaining on date of delivery. One U.S. manufacturer of milling machines has advanced his quotations 10 per cent. A Cleveland concern contemplates making an advance on milling machines and shapers.

Supplies

The general situation as regards machine shop and mill supplies has now changed materially from last week. Business continues very brisk and prices on all lines are very firm. The high cost of pig lead has naturally resulted in an advance on lead products, including lead sheets which are now 2c higher. Gasoline, benzine and coal oil have each advanced 1c per gallon, and further advances are expected during the year. There appears to be a great scarcity of linseed oil, and prices, therefore, are entirely nominal.

Metals

There is practically no change in the situation in the metal markets, and prices have been maintained at last week's level. The general tendency of the market continues strong, due for the most part to the expectation that the United States will ultimately be drawn into the war. Copper continues strong with prices still nominal. Tin although higher in London is unchanged here. Prices of tin are also nominal, the market being affected by submarine operations. Spelter and lead are firmer at unchanged quotations, while antimony is quiet and easier.

Copper.—There have been no recent developments of importance in the copper market. Spot and nearby demand has not been so active, although a fair volume of business has been done in third quarter copper. Early deliveries continue scarce, and the general aspect of the market continues to be one of waiting developments. Quotations continue nominal and unchanged at 39c per pound.

Tin.—Although the price of tin has advanced in London, local quotations

are unchanged, but market is firm. Submarine activities are affecting the market although it is understood that very little tin has as yet been lost. Local quotations are nominal and unchanged at 56c per pound.

Spelter.—Supplies of spelter in the East are more plentiful, and the situation has been relieved to some extent. There is no real shortage of metal, as production is large enough to take care of the present demand. Local quotation unchanged at 14c per pound.

Lead.—The "Trust" price of lead which for some time has been below the outside market has been advanced to 9c New York. Independents, however, are still quoting 10.25c to 10.75c New York for spot metal. There has been a marked falling off in demand, but the advance is expected to stimulate business. Local quotations unchanged at 12½ per pound.

Antimony.—The market is quieter though still firm, due to the continued scarcity of antimony. Local price 35c per pound.

Aluminum.—The market is firm with a slight upward trend but local quotations are unchanged at 68c per pound.



**LATIN-AMERICAN TRADE
POSSIBILITIES**

THE following paragraphs, taken from the *Pan-American Union*, are descriptive of trade possibilities in Central and South America:—Broadly speaking, Latin-America is one of the new quarters of the world. It has an older culture than ours, and it would be to our advantage to study the systems of thought and law, and other things that count in life that dominate in Spanish and Portuguese America. Nevertheless, for lack of economic pressure and, until quite recently, of immigration and, because of the enormous extent of natural resources, there has been no general mastery and development of those resources. In most Latin-American countries, the people to-day are merely living on the fringe of the country, so far as natural wealth and possibilities are concerned.

The vast continent of South America, and the by no means inconsiderable territory of Central America nor ought we to forget the Latin West Indies offer an inviting market for the widest possible variety of our products and, indeed, for products of which we have yet produced no respectable quantity for purposes of export. The chief demand in all the Latin countries is for what we may call medical products, that is to say, for those things that are directly necessary for the protection of native raw materials. Thus everything that enters into the development of railways and transportation facilities generally is an absolute necessity for every Latin-American country whenever it sets out to develop its resources one stage further than that which it has reached. That surely should be a significant fact for the people of this country. They might long ago have taken

vigorous steps to associate in the Latin-American mind all that is new and comprehensive in railroad expansion and railroad facilities with American capital and American exporters.

Rolling Stock of British Origin

At present the railroads of Argentina are owned in England, and the locomotives there have been made in Leeds. In Brazil only a small part of the rolling stock has come from the United States, and in Chile a few specimens from the Baldwin works, but for the most part the rolling stock has come from England or the continent of Europe. As in railroad development so in the industries dependent upon the production of power; everywhere power houses are being constructed in Latin-America in connection with municipal enterprises or the activities of public-service corporations. The machinery and, equally important, the fuel have largely to be supplied from abroad. The South American continent has disclosed but little fuel except, perhaps, Argentina's recently discovered petroleum, and the Colombian and Peruvian oil wells, both of which fields have not yet reached an advanced stage of development, and a certain quantity of coal in the southern part of Chile.

Demand for Manufactured Goods

There is a demand for manufactured articles of every possible and imaginable type, and, above all, those which have to do with agriculture. Uruguay, Southern Brazil, and Argentina form one of the great wheat regions of the world. The demand for sugar machinery is growing constantly in the tropical section of the continent; and the Brazilian cotton market is going to take its place some day beside that of the U.S. Southern States and of Egypt. Then, too, all the luxurious accompaniments of refined taste are in demand, and these tastes in Latin-America are in a remarkable degree to be found everywhere, and in no way inferior to those which characterize the greatest capitals of the world. The Latin-American even of moderate standing enjoys a cultivated acquaintance with the fine things of Europe with European literature and drama, with the finest costumes that Paris and London can produce a familiarity that is, indeed, rare in the United States. If a professional man, he is closely in touch with all that goes on in the European centres of his profession; he has the latest law books from Paris, the latest scientific instruments from Germany, and is constantly alive to all the intellectual currents of Europe. The intimacy between Latin-America and Europe is bound to create a strong demand throughout Central and South America for Articles of refinement and culture and to create there at least an excellent market.

Raw Materials in Exchange

What has Latin-America to give in return for these by no means inconsiderable demands that she makes upon the rest of the world? She can give raw

products and those alone. Grain, fruit, meat, coffee, wool, hides, fine woods and dye woods, rubber, precious metals, and industrial minerals—these are the things that Latin-America has and which she proposes to exchange either for tools with which to get further supplies of raw material or for objects requisite to the ordinary carrying on of a highly organized and complex social system. Of any one of the materials mentioned, Latin-America seems to possess an inexhaustible supply, and her capacity to meet the growing requirements of the rest of the world for these things would appear to reach as far as human vision can foretell. In proportion as the necessities of transportation are met, and the difficulties of extracting and preparing for shipment or even for manufacture on the spot of these raw products, the economic wealth of Central and South America will loom larger and larger in the eyes of international economists.

Investments of Great Britain Are Prodigious

Let us see briefly how these things balance and what conditions will result. So far as Latin-America has been developed to this stage she owes it pretty much wholly to Europe. To-day, except possibly for one or two Central American Republics, the Latin-American world is dominated by Europe financially and commercially. The investments of Great Britain alone are really prodigious, amounting to fifty-one hundred millions of our money in public loans, national or local, in public-service corporations, and in banking and transportation. To some extent the vast trade that Great Britain enjoys with Latin-America is nothing more than disguised interest upon these great investments. Great Britain has come to depend upon the food products of Latin-America to such an extent that her subsidized shipping lines, which have to maintain a continuous stream of food-bearing vessels from Argentina and Uruguay to England, have always been willing to reduce the outgoing freight rates even below actual cost in order not to have the boats, which necessarily must return to South America, go out empty. That, perhaps, is the secret why the exporter from the United States has often found it cheaper to send his goods to Southampton for transmission to Latin-America than to send them direct from Boston or New York.

Banking Facilities

Moreover, European banks have been in South America in some cases for nearly a century, and they have been very strongly established for over a half century. These banks are ready to give credit, and they are so closely allied with the merchant that they are always willing to back him up and enable him to sell credit, although his main business is to sell merchandise and not credit. The power of these European financial institutions is soon realized by any man who seeks to enter a Latin-American market. This South American market is inviting, but we will have to work fairly hard to earn a share therein.

Enlarged Canadian Trade Intelligence Service

Under the arrangement made by the Minister of Trade and Commerce with Sir Edward Grey in July, 1912, the Department of Trade and Commerce, Ottawa, is able to present the following list of the more important British Consulates whose officers have been instructed by the Foreign Office to answer inquiries from and give information to Canadians who wish to consult them in reference to trade matters.

BRAZIL—Bahia, British Consul. Rio de Janeiro, British Consul General.	NETHERLANDS—Amsterdam, British Consul.
CHILE—Valparaiso, British Consul General.	PANAMA—Colon, British Consul. Panama, British Vice-Consul.
COLOMBIA—Bogota, British Consul General.	PERU—Lima, British Vice-Consul.
ECUADOR—Quito, British Consul General. Guayaquil, British Consul.	PORTUGAL—Lisbon, British Consul.
EGYPT—Alexandria, British Consul General.	RUSSIA—Moscow, British Consul General. Petrograd, British Consul. Vladivostok, British Consul. Odesa, British Consul General.
FRANCE—Havre, British Consul General. Marseilles, British Consul General.	SPAIN—Barcelona, British Consul General. Madrid, British Consul.
INDIA—Calcutta, Director General of Commercial Intelligence.	SWEDEN—Stockholm, British Consul.
ITALY—Genoa, British Consul General. Milan, British Consul.	SWITZERLAND—Geneva, British Consul.
MEXICO—Mexico, British Consul General.	URUGUAY—Monte Video, British Vice-Consul.
	VENEZUELA—Caracas, British Vice-Consul.

Canadian Commercial Intelligence Service

The Department of Trade and Commerce invites correspondence from Canadian exporters or importers upon all trade matters. Canadian Trade Commissioners and Commercial Agents should be kept supplied with catalogues, price lists, discount rates, etc., and the names and addresses of trade representatives by Canadian exporters. Catalogues should state whether prices are at factory point, f.o.b. at port of shipment, or, which is preferable, c.i.f. at foreign port.

CANADIAN TRADE COMMISSIONERS.

ARGENTINE REPUBLIC—H. R. Poussette, Reconquista, No. 46, Buenos Aires. Cable address, Canadian.
AUSTRALIA—D. H. Ross, Stock Exchange Building, Melbourne. Cable address, Canadian.
BRITISH WEST INDIES—E. H. S. Flood, Bridgetown, Barbadoes, agent also for the Bermudas and British Guiana. Cable address, Canadian.
CHINA—J. W. Ross, 13 Nanking Road, Shanghai. Cable address, Caucoma.
CUBA—Acting Trade Commissioner, Lonja del Comercio, Apartado 1290, Havana. Cable address, Contracom.
FRANCE—Phillipe Roy, Commissioner General, 17 and 19 Boulevard des Capucines, Paris. Cable address, Stadacona.
JAPAN—G. B. Johnson, P. O. Box 109, Yokohama. Cable address, Canadian.
HOLLAND—Acting Trade Commissioner, Znidblaak, 26, Rotterdam. Cable address, Watermill.
RUSSIA—C. F. Just, Canadian Government Commercial Agent, Alexandrivskaya. Ploshch 9, Petrograd. L. D. Wilgress, Canadian Government Commercial Agent, Bukhholza Ulitza No. 4, Omsk, Siberia.
NEWFOUNDLAND—W. B. Nicholson, Bank of Montreal Building, Water Street, St. John's. Cable address, Canadian.
NEW ZEALAND—W. A. Beddome, Union Buildings, Customs Street, Auckland. Cable address, Canadian.
SOUTH AFRICA—W. J. Egan, Norwich Union Buildings, Cape Town. Cable address, Contracom.
UNITED KINGDOM—Harrison Watson, 73 Basinghall Street, London, E.C., England. Cable address, Sleighing, London. N. D. Johnston, Sun Building, Clare Street, Bristol. Cable address, Canadian. J. E. Ray, Central House, Birmingham. Cable address, Canadian. J. Forsyth Smith, 27-28 Pearl Building, East Paradise, Leeds. Cable address, Canadian. F. A. C. Bickerdike, Canada Chambers, 36 Spring Gardens, Manchester. Cable address, Contracom. J. T. Lithgow, 87 Union Street, Glasgow, Scotland. Cable address, Contracom.

SPECIAL TRADE COMMISSIONER—LUMBER

H. R. McMillan, visiting Europe, Africa, Australasia and the Orient.

CANADIAN COMMERCIAL AGENTS

AUSTRALIA—E. Millin, Exchange Building, Sydney, N.S.W.
BRITISH WEST INDIES—Edgar Tripp, Port of Spain, Trinidad. Cable address, Canadian. R. H. Curry, Nassau, Bahamas.
NORWAY AND DENMARK—C. E. Sontum Grubbedged No. 4, Christiania, Norway. Cable address, Sontums.

CANADIAN HIGH COMMISSIONER'S OFFICE

UNITED KINGDOM—W. L. Griffith, Secretary, 17 Victoria Street, London, S.W., England. Cable address, Dominion, London.

INDUSTRIAL ^A_D CONSTRUCTION NEWS

Establishment or Enlargement of Factories, Mills, Power Plants, Etc.; Construction of Railways, Bridges, Etc.; Municipal Undertakings; Mining News

ENGINEERING

Guelph, Ont.—The Page Hersey Iron Tube & Lead Co., has awarded the contract for the erection of an addition to its plant to cost \$3,500.

Princeton, B.C.—The Canada Copper Corporation is to erect a 2,000-ton mill here and will construct 13 miles of railroad to mines on Copper Mountain. Work will cost about \$2,000,000.

Coaticook, Que.—Penman's Ltd., propose to erect a power house, construct a concrete dam, and install 150 h.p. turbine and generator. Engineers, T. Pringle & Sons, Ltd., Montreal.

New Hazelton, B.C.—The Santa Maria Mine has commenced mine development at Telkwa, B.C. Machinery consisting of drills, compressors, hoists, pumps, and gas engine will be installed.

Thorold, Ont.—The Exolon Co., manufacturer of abrasive refractory materials, has commenced the erection of an addition to its plant, and will install equipment so as to increase the production by 100 per cent.

St. Thomas, Ont.—The plant of the C. Norsworthy Co., known as the Red Foundry, was badly damaged by fire on Feb. 28. The origin of the fire is unknown. The loss, \$20,000, is partly covered by insurance. The company will rebuild at once.

St. John, N.B.—It is reported here that a plan to establish a steel ship-building plant on the Miramichi River, in Northern New Brunswick, is being worked out. Two million dollars is said to be the capitalization. Montreal money is understood to be in the deal.

Hull, Que.—Fire which broke out in the plant of the Hull Steel and Iron Foundries Ltd., on Sunday afternoon caused damage to the extent of between \$4,000 and \$5,000 to the building and its contents. The loss is fully covered by insurance.

Parry Sound, Ont.—The new plant of the British Cordite Co., to be built at Parry Sound by the Canadian Explosives, Ltd., for the Imperial Munitions Board, will probably be the largest work of its kind in Canada. Orders for the material and equipment are being placed by the Canadian Explosives, Ltd., Montreal.

Haileybury, Ont.—The Riordon Pulp & Paper Co., which established a roasting plant at Haileybury two years ago, is planning to erect a large sulphite plant in the same neighborhood. Surveys for the site of a 500-ton mill are now being carried out and it is proposed to have the first unit of 100 tons ready by January. The mill, if completed to the 500-ton capacity now under con-

sideration, would be easily the largest of its kind in Canada.

Trenton, Ont.—The Church-Ross Co., of Montreal, it is said, have taken over the contract of the Gaylord Engineering & Construction Co. here, and work in the different departments is fast nearing completion. Messrs. Fraser, Bruce & Co., of Montreal have a contract for the smokeless powder plant, and have commenced operations.

Windsor, Ont.—A contract has been closed with the Canadian Steel Corporation and the Hydro-Electric Commission for two thousand horse power of Niagara current. The contract provides that the steel company shall use not less than 2,000 h.p. for the next 20 years, and after that period have the option of purchasing an additional 3,000, making 5,000 h.p. in all.

Victoria, B.C.—With a capitalization of one million dollars, the Ladysmith Smelting Corporation, has been incorporated and will operate, the old Tye smelter at Ladysmith, which was recently purchased from English owners by United States capitalists, at the head of whom are Col. Stevenson, an Alaskan mining man, and F. A. Seiberling, head of the Goodrich Tire & Rubber Co. Offices have been opened here in the Belmont block. Additions to the plant will increase its capacity to 1000 tons per day.

MUNICIPAL

Bothwell, Ont.—The Town Council are considering installing a waterworks system.

Brantford, Ont.—The City Council are considering the question of installing pumps in connection with the water works system.

Kincardine, Ont.—The Town Council will submit a by-law shortly to provide free site for a \$50,000 factory to be erected by J. B. Watson.

Hull, Que.—The city council will call tenders about May 1, for a mechanical filtration plant to cost \$170,000. J. P. A. Laforest is engineer.

Caledon Township, Ont.—A by-law has been passed to raise \$5,000 to provide for the cost of works, plant, machinery and appliances for the village of Alton.

London, Ont.—The City Council has decided to include in the City of London bill to be presented in the Legislature provision for the erection by the Railway Commission of a modern grain elevator at Port Stanley. It will cost about \$100,000, and will assure London of at least one large new industry this year.

Sherbrooke, Que.—The City Council proposes to purchase Two Miles Falls at Weedon and to erect power plant and transmission lines to Sherbrooke, at a cost of \$1,500,000. Francis & Co., Montreal, are consulting engineers.

Brantford, Ont.—Fire Chief D. J. Lewis, has recommended the purchase of the following:—Combination hose and pumping auto truck, 800 gallons per minute, \$10,000. Motor tractor ladder truck \$5,000. Storage battery system to replace present gravity battery system \$1,800.

Ottawa, Ont.—The City Council has awarded contracts for their 1917 supplies as follows:—Lead pipe and pig lead, Canada Metal Co., Toronto; castings and special pipe castings, Thos. Lawson & Sons; oils and grease, Imperial Oil Co.; cast iron pipe, National Iron Works, Toronto.

GENERAL

Montreal, Que.—The Walter M. Lowney Co., will build an addition to their factory.

Grimsby, Ont.—The Metal Craft Co., have obtained a building permit to erect a factory here at a cost of about \$4,000.

Toronto, Ont.—The B. J. Johnson Soap Co., have purchased a site and expect to erect a factory and warehouse to cost \$50,000.

Longueuil, Que.—Mr. Bruay of the Belgian-Canadian Glass Co., is negotiating with the town regarding the building of a glass plant here.

Winnipeg, Man.—Fire last Monday destroyed the plant of the Armstrong Trading Co., with an estimated loss of between \$50,000 and \$75,000.

St Hyacinthe, Que.—Duclos & Payan, will build a factory for the manufacture of leather goods, etc. Ross & Macdonald, 1 Belmont street, Montreal, are the architects.

Preston, Ont. A by law authorizing the town to endorse bonds for the Preston Car and Coach Co., to the extent of \$75,000 was carried last Monday by the ratepayers.

Ottawa, Ont.—W. J. Trick's industry, known as the Oshawa Interior Fittings Works, was totally destroyed by fire early on March 1. The loss is estimated at from \$75,000 to \$100,000, but, it is understood, is well insured.

Oshawa, Ont.—The Pre-Cast Concrete & Supply Co., have taken over the plant of the Concrete Builders Ltd., and propose to install machinery for making concrete bricks, blocks, etc. T. P. Parker of Oshawa is interested in the new concern.

Toronto, Ont.—The City Architect has issued a permit to Canadian Aeroplanes, Ltd., for a brick addition to the Fuselage factory, on the west side of Dufferin street, near Lappin to cost \$25,000.

Niagara Falls, Ont.—Construction work will be started immediately on the erection of a new plant at Niagara Falls, for the American Cyanamid Co., whose plant was recently damaged by fire to the extent of \$250,000.

PERSONAL

Richard Bell, for the last twenty-three years chief engineer of the pumping station at Sarnia, Ont., died on February 19th, aged 43.

G. Gordon Gale, formerly general manager and chief engineer, Hull Electric Co., has been appointed vice-president and general manager.

John R. McDonald, who has for several years been successfully in charge of the mines of the Franco-Canadian Collieries, at Frank, B.C., has resigned.

Capt. James N. P. Ritchie, master of the C. P. R. steamer Princess Patricia, died at Victoria on Feb. 21. Capt. Ritchie was born in Yarmouth, N.S., 58 years ago.

James S. Paige, who for some time has been associated with the Fore River Shipbuilding Co., of Quincy, Mass., has been appointed general manager of the Port Arthur Shipbuilding Co.

D. Walter Munn, of the Montreal Rolling Mills Branch of the Steel Company of Canada, has joined the engineering department of the Algoma Steel Corporation, Sault Ste. Marie, Ont.

George Dawson, who has been master mechanic of the Canada Stove & Foundry Co., St. Laurent, Montreal, and who is leaving to accept a position in Campbellford, Ont., was given a farewell supper and presented with a quarter-oak cabinet and a silver tea service at the factory on Feb. 26, by his fellow-workers.

Major John Roaf Barber, president of the Barber-Ellis Co., paper dealers and envelope manufacturers of Toronto, and one of the pioneer paper manufacturers of Canada, died last Saturday at his home in Georgetown, Ont., in his 77th year, after an illness of three months. Mr. Barber had been actively connected with the Barber-Ellis Co. for over forty years, and was also president of the Wm. Barber & Bros., Georgetown, Ont. Mr. Barber was born in Georgetown in 1841.

TENDERS

London, Ont.—The County Council of Middlesex, are in the market for a 10-ton steam road roller. Tenders received until March 22. John Stuart, county clerk.

Yorkton, Sask.—Tenders are being received for the following:—One 357 h.p. oil engine, one 280 k.w. generator, one transformer down to 30 kw., 450 feet of 4-inch cast iron pipe, 200 pounds of

lead. Further particulars from F. J. Pilkington, town clerk.

East Angus, Que.—Tenders for the construction of a Boys' Academy at East Angus, will be received at the secretary-treasurer's office until March 15. Plans and specifications will be seen and all informations obtained at the secretary's office at East Angus. J. E. Palmer, secretary-treasurer.

Winnipeg, Man.—Tenders will be received up to March 9, for the supply and delivery of one electrically operated, three-phase oil switch for the city's terminal station. Instructions to bidders, specifications and form of tender may be received at the office of the City Light and Power Department, 54 King street.

Ottawa, Ont.—Tenders addressed to the chairman of the Board of Control, will be received up to March 13, for the supply and delivery of: 10 roller type, single horse refuse wagons; 18 two-horse rectangular box refuse wagons; 4 two-horse bottom dump refuse wagons. Specifications and full particulars may be obtained on application to the City Engineer's office, City Hall, Ottawa.

Quebec, Que.—Tenders, addressed to the secretary-treasurer of the Municipality of Halifax-South, will be received until March 25, for the construction of two highway bridges, with steel superstructure, concrete abutments, approaches, etc., on the Fortier and Pidgeon Rivers (ten arpents distant in the Parish of St. Ferdinand d'Halifax, Mecanic County. Plans and specifications may be examined at the Council's Office and at the Department of Public Works and Labor, Quebec.

INCORPORATIONS

The Thompson Powder Co., has been incorporated at Toronto with a capital of \$500,000 to manufacture all kinds of explosives at Deseronto, Ont. The provisional directors are Fred C. Sutherland, Hugh H. Sutherland and Norman C. Urquhart all of Toronto.

Kingston, Ont.—The St. Lawrence Smelting & Refining Co., has been incorporated to carry on smelting and to manufacture metals of all kinds, with \$100,000 capital, by Frederick H. Markey, Waldo W. Skinner, and Wilson G. Pugsley, all of Montreal, Que.

International Shipbuilding Corporation has been incorporated at Ottawa with a capital of \$2,000,000 to construct and operate ships of all kinds with head office at Montreal. The incorporators are Henry A. Lovett, George W. Cole and B. F. Bowler all of Montreal.

Canadian Coal Products Engineering Ltd., has been incorporated at Ottawa with a capital of \$1,250,000 to operate coal mines and manufacture coal products with head office at Toronto. The incorporators are A. J. Reid, Norman Limpriht and William Bowler all of Toronto.

Standard High Speed Steel Hardening Co., has been incorporated at Ottawa with a capital of \$150,000 to carry on business as metal manufacturers, founders, machinists, etc., at Montreal. The incorporators are Anthime Fortin, Frank Willdon and Francis Guerin all of Montreal.

Canadian Rein Drive Tractors Ltd., has been incorporated at Ottawa with a capital of \$1,000,000, to manufacture tractors, motors and machinery of all kinds. The head office is at Toronto and the incorporators are Henry J. Martin, Charles Evans-Lewis and Edmund H. Austin all of Toronto.

Shell-Bar Boico Supply Co., has been incorporated at Toronto with a capital of \$40,000 to manufacture munitions, and tools, etc., and to take over the Shell-Bar Grate Co. and Boico Ltd. Head office is at Toronto and the provisional directors are Henry D. Lanz, George S. Moffatt and J. L. Wilson all of Toronto.

The Kingsdale Box Co., has been incorporated at Toronto with a capital of \$60,000 to take over the business of lumber and woodenware business formerly carried on by Ross & Branscombe at Kingsdale Village, York County. The incorporators are William P. Gillespie, and Harry K. Bowes of Toronto and B. Ross of Newmarket, Ont.

Carbon & Alloy Steels Co., has been incorporated at Ottawa with a capital of \$1,500,000 to take over the Moffatt-Irving Steel Works, Toronto and to operate a steel foundry at Hamilton, Ont. The incorporators are James B. O'Brien and James W. Moffatt of Toronto and Henry J. Waddie of Hamilton, Ont.

MARINE

Sarnia, Ont.—Capt. J. Reid has purchased the outfit cruiser Reo and will use her in connection with the reid wrecking tugs this season. The boat is 50 feet in length and fitted for long trips.

Quebec, Que.—The manager of one of the leading ship-building companies of Lunzon has just returned from New York, with a contract for the construction of fifty wooden vessels of the same style as those built last year only somewhat heavier.

Victoria, S.C. The Norwegian steamer Strinda, Capt. Lovedahl, after undergoing extensive repairs and overhaul at Yarrows, Ltd., has left for Vancouver. The steamer, which is under charter to the C.P.R., will load a capacity cargo for Vladivostok.

Halifax, N.S.—During the past week applications were received at the Board of Trade office from two different parties for information regarding steel ship-building and the site available. This makes the third such application within a month.

St. John, N.B.—It is reported here that a plan to establish a steel ship-

Aikenhead's

Anderson Die-Forming Machine

*means larger and better
production*

Advantages---

secured by the use of this machine as compared with a reciprocating filing machine for finishing blanking dies:—

1. Work drawn down on table or platen.
2. A wide range of surface contours finished without change of cutters.
3. Surfaces finished with uniform degree of clearance regardless of direction from which work is applied to cutter.
4. Chips carried downward, not deposited on top of the die to obscure the pattern or layout.
5. Will remove very much more material in a given time than is possible with a reciprocating file.

Write for catalog and full information.

Aikenhead Hardware, Limited

17, 19, 21 Temperance Street, Toronto, Canada

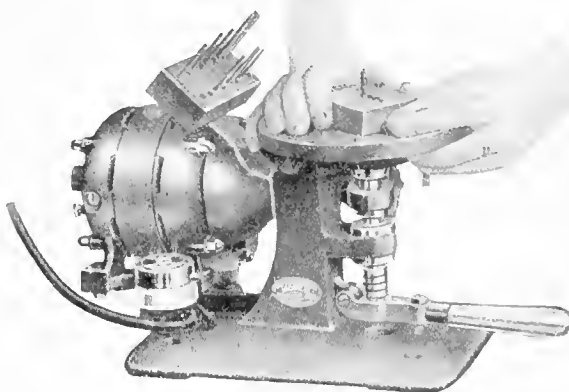

Aikenhead's

Are You Losing Drilling Profits?

Minutes mean profit—are you losing minutes? With the WAHLSTROM CHUCK there is no loss of time in tool changes.

It is entirely automatic in action—tool changes may be made without stopping—just grasp the shell of the chuck with one hand and make the tool changes with the other—the change is made in one-tenth of the time required for the ordinary chuck—and the tool automatically centers itself.

The WAHLSTROM CHUCK is made in two types—one for straight shank tools—the other for Morse Taper Shank Tools.

Write for information.

Aikenhead Hardware, Limited

17, 19, 21 Temperance Street - - Toronto, Canada

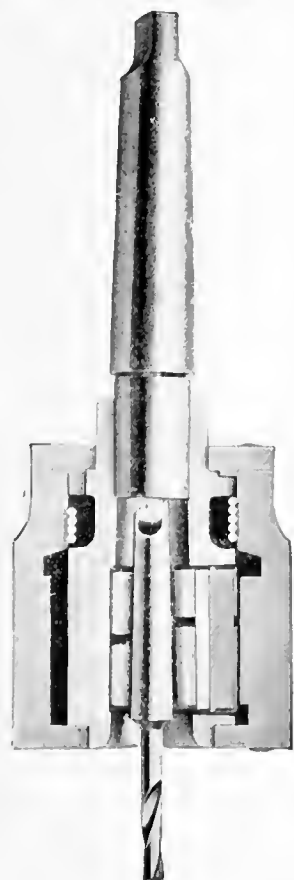

If any advertisement interests you, tear it out now and place with letters to be answered.

building plant on the Miramichi River in Northern New Brunswick is being worked out. Two million dollars is said to be the capitalization. Montreal money is understood to be in the deal.

Victoria, B.C.—According to an announcement made by Captain C. H. Nicholson, manager of the G. T. P. coast steamship service, important structural alterations have been ordered for the steamer Prince John which is at present repairing at the Wallace Shipyards, North Vancouver, after her stranding in Wrangel Narrows a few weeks ago.

Victoria, B.C.—The C.P.R. steamer Princess Patricia, which is undergoing repairs at the plant of the Victoria Machinery Depot following her recent mishap by stranding on the Spanish Banks while on her regular run between Nanaimo and Vancouver, is expected to be ready to take the water very shortly. The work on the Patricia has proved to be bigger than was anticipated.

Vancouver, B.C.—Contracts have been let by the Dominion Government for the construction of two auxiliary schooners promised some time ago. The vessels, which will be used in the trade between Victoria, Vancouver and Halifax, via the West Indies, will cost approximately \$250,000 each and the contract stipulates they must be ready for commission by September next. The vessels will be on similar lines to those now under construction for the Brown syndicate. The Wallace Shipbuilding yards at North Vancouver will build one of the vessels and the Cameron-Genoa Shipbuilders, Ltd., at Victoria, the other.

BUILDINGS

Montreal, Que.—Permission has been granted the St. Jean Baptiste School Commission to issue debentures for \$275,000 to erect a school on Berri street and Chateaubriand avenue, by the Board of Catholic School Commissioners of Montreal. The school will have a frontage of 206 feet on Berri street and 220 feet on Chateaubriand.

TRADE GOSSIP

Saskatoon, Sask.—The Saskatchewan General Development Co., has been organized with a capital of \$1,500,000 to build pipe lines and supply natural gas to municipalities in the province.

Montreal, Que.—The C.P.R. are building at the Angus Shops, 260 automobile cars with double decks, and specially adapted for the accommodation of motor cars during railroad transportation.

Windsor, Ont.—The signing of a contract between the local Hydro Commission and the Canadian Steel Corporation will lower the hydro rate at Windsor from \$39 to \$31 per horsepower.

Prohibit Export of Cyanide of Sodium.—The exportation of cyanide of sodium and compounds and mixtures containing cyanide of sodium, from Canada to countries other than the United Kingdom, British Possessions and Protector-

ates, has been prohibited by Order-in-Council.

G.T.R. Order Ten Engines.—The Canadian Locomotive Works, Kingston, Ont., have succeeded in closing a contract with the Grand Trunk Railway system for ten large Mikado-type locomotives.

The Cockshutt Plow Co., Brantford, Ont., are making tractor plows for the British market. Over 500 have already been shipped to the Old Country and the company have orders on hand for 400 more.

The Illinois Tool Works, Chicago, Ill., have opened an office in 403 C.P.R. Building, Yonge and King streets, Toronto, in charge of Allan B. Wearing who has been appointed Canadian representative.

Durham, Ont.—The National Portland Cement Co. is now manufacturing at its plant, near here, a considerable quantity of potash from feldspar as a by-product. The output of potash, which is being used as a fertilizer, is 14 to 16 tons per day.

Flotation Plant Reduces Loss.—The 150-ton oil flotation plant which was recently installed at the Cominas Mine is understood to be resulting in a larger recovery than was anticipated. The loss now is said to be less than one ounce of silver to the ton.

The Canadian Fairbanks-Morse Co., Ltd., Toronto, has been awarded a contract by the City Council, of Kitchener, Ont., for a motor-driven centrifugal pump, consisting of a 25 h.p. Fairbanks-Morse motor direct connected to a Fairbanks-Morse centrifugal.

The Canadian Fairbanks-Morse Co., Ltd., Toronto, have secured a contract from the Town Council of Bothwell, Ont., consisting of a 24 h.p. oil engine, direct connected to a Goulds triplex pump for fire purposes, and a motor-driven centrifugal pump for domestic purposes.

Ontario's Heavy Fire Loss.—E. P. Heaton, Provincial Fire Marshal, addressing the Mutual Underwriters' Association, said that the fires in Ontario during the past year numbered over 8,900, with an aggregate loss of \$12,000,000. This, Mr. Heaton said, was the highest fire loss in the Province in any year since the great Toronto fire.

British Shells for U.S. Navy.—It is reported that Great Britain has withdrawn her objection and given permission for Hadfields, Ltd., to contract with the United States navy for large armor-piercing shells. The withdrawal of objection by the British Government may cause the secretary to re-award the contract to Hadfields.

Toronto Man's Patriotic Gift.—Prime Minister Lloyd George has received a cablegram from David J. Johnston, Canada Nitro Products, Toronto, presenting to the nation, to aid in agricultural work, 100 farm tractors of a type considered the most efficient yet designed. The gift includes harrows, binders and

other implements. A skilled mechanic will accompany each tractor. Lloyd George replied gratefully accepting the generous gift on behalf of the nation.

Trade With France.—L'Office National du Commerce Exterieur, 3 Rue Feydean, Paris (France), is an address that should prove useful to Canadian buyers or agents wishing to be placed in touch with the best French manufacturers and producers. Prospective buyers or agents should state very clearly just what they want, and furnish references. Correspondence in English is welcomed.

No Work for the Unskilled.—Dr. A. H. Abbott, director of the Imperial Munitions Board for the Ontario Department of Labor, in a letter to President Falconer of Toronto University, states that there is little need for unskilled help in munition factories at present, and the problem which has to be considered is that of help for the farmers. He points out that in May there may be a greater need for unskilled help in munition factories, because it is probable some of the men employed in the latter at present will go on the farms.

Big Increase in Customs Revenue.—The Customs revenue of Canada for the fiscal year which ends on March 31 will probably exceed that of the last fiscal year by more than forty million dollars. The revenue from customs duties for February the Minister of Customs announced on Feb. 27 amounted to \$11,190,000, or \$1,062,000 more than those of the corresponding month in 1916. For the eleven months of the fiscal year which have now passed Canada's customs revenue amounted to \$130,739,000, as compared with \$91,946,000 in the same period of the last fiscal year, or an increase of \$38,793,000.

Cunard Line on Pacific.—Sir William Mackenzie is authority for the statement that the contract which the C.N.R. made with the Cunard Steamship Co. for the taking over and operating of the former company's Atlantic service contemplates the establishment of a service on the Pacific to be run in conjunction, with the company's land service. Under the contract made it is intended that a trans-Pacific service between Canada and the Orient shall be established. The Cunard Co., has just let contracts for ships to be built in Seattle yards, and these will, when ready, be placed on the Pacific route.

Further Recession in Shipping Risks.—Further recession has taken place in war risk insurance on Atlantic voyages. The rate is now as low as 6½ per cent., compared with 10 per cent. at the beginning of February. Some underwriters, however, are charging 8 per cent. The low rate is on liners and armed belligerent ships bound for the war zone. Mediterranean rates continued at 10 to 12 per cent. and South American rates have held firm at from 5 to 8 per cent. The raider in the Indian Ocean is expected to cause an increase. Some New York underwriters quote war risk

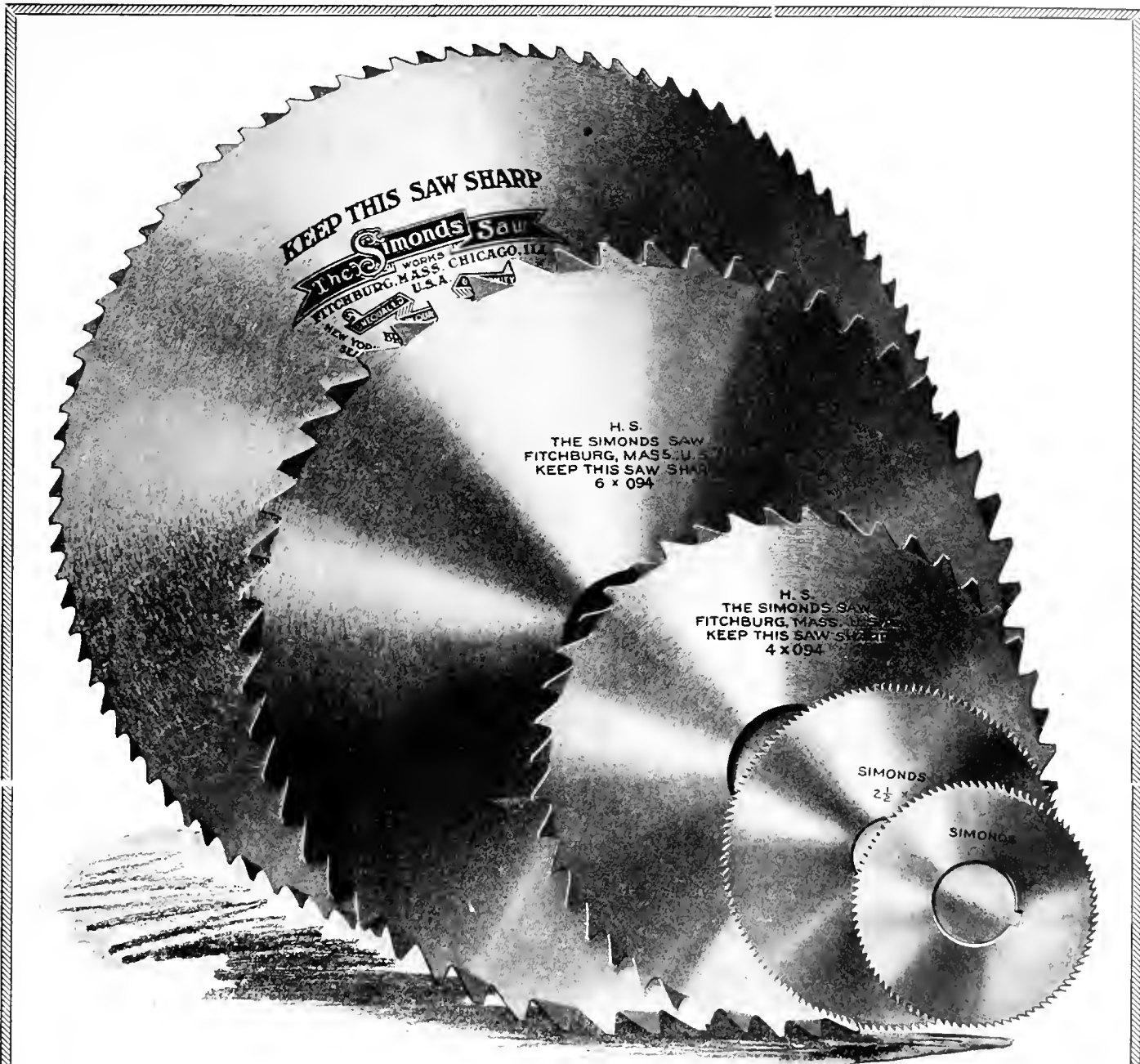

Metal Cutting Saws Slitting Saws Screw Slotting Saws

We are Saw Makers. We realize that if there is one place where quality counts more than another, it is in the steel and workmanship in Metal Cutters. We would like to discuss this matter more fully with you. When writing for quotation, specify whether Carbon Steel, Semi-High Speed Steel or High Speed Steel Saws are wanted, the date of delivery, and the number wanted, and send blueprint or give full specifications. To avoid delay, send orders at once.

Simonds Canada Saw Company, Limited

St. Remi Street and Acorn Avenue
MONTREAL, QUEBEC

Vancouver, B.C.

St. John, N.B.

If any advertisement interests you, tear it out now and place with letters to be answered.

insurance contingent upon shipments within two weeks.

The Turbine Equipment Co., Toronto, have recently closed contracts with the following towns for pumping equipment. Town of Lindsay, 1-De Laval 2 stage pump having a capacity of $1\frac{1}{4}$ Imperial gals. a day, for domestic requirements, and $1\frac{3}{4}$ Imperial gals. a day for fire requirements. A vertical high speed gasoline engine will be connected by clutch to one side of the pump, and the electric motor on the other. Contract price was \$8000, including installation. From the town of Barrie, Ont., 1- $1\frac{1}{2}$ million Imperial gals. a day, De Laval single stage centrifugal pump, to operate against 87 lbs. pressure and direct connected to 100 h.p. electric motor. From international Nickle Co., Port Colborne, Ont., 1-De Laval 130 h.p. steam turbine driven centrifugal underwriter fire pump.

Engineers Organize for Service.—The engineers and technical men belonging to the various branches of the profession in Ontario have recently organized to lend their technical knowledge in the service of their country. The new movement is known as the Joint Committee of Technical Organizations, Ontario Branch, and is governed by a strong committee composed of representatives from all the known engineering associations of the Province. Representatives have been selected from such institutions as the Canadian Mining Institute (Toronto branch), Canadian Society of Civil Engineers (Toronto branch), Ontario Association of Land Surveyors, Society of Chemical Industry, Canadian section (Ontario members), Engineering Alumni Association of the University of Toronto, Engineers' Club, Toronto, Royal Canadian Institute, Canadian Engineers (Military District No. 2), American Society of Mechanical Engineers (Ontario section), American Institute of Electrical Engineers (Toronto section), Institution of Electrical Engineers (Ontario members), Ontario Association of Architects.

WOODWORKING

Warton, Ont.—The Canadian Furniture Mfg. Co. will build an addition to its plant and instal new machinery.

New Westminster, B.C.—The Brunette Sawmills Co. will build an engine and boiler house. The new shingle mill is practically completed.

RAILWAYS—BRIDGES

Fort William, Ont.—M. H. McLeod, general manager of the Western Lines of the C.N.R., stated recently that as soon as the weather is favorable work will be commenced on a \$50,000 station in Fort William. The station, which will be of the same model as the depot in Port Arthur, will be erected a short distance north of the present station.

CONTRACTS

Toronto, Ont.—Reid & Brown have been relieved of their contract to supply gully tops to the city at \$5.55. The contract was awarded to The Don Foundry Co., at \$6.70 per ton.

CATALOGUES

Circulating Pumps.—A bulletin dealing with a line of circulating pumps for machine tools, has been issued by C. F. Roper & Co., Hopedale, Mass. The principal features of construction and method of operation on the Roper geared pump are described fully, accompanied by illustrations which include dimensioned diagrams for various sizes.

Hydraulic Presses.—An interesting and varied line of hydraulic presses is described and illustrated in a series of leaflets distributed by the Charles F. Elmes Engineering Works, Chicago, Ill. The principal dimensions are given for the various sizes of each type, and also of equipment used in their operation such as hydraulic pumps, valves, etc.

Storage Battery Trucks.—The Buda electric storage battery trucks for railroad shops and manufacturing establishments, made by the Buda Company, Chicago, Ill. Bulletin illustrating and describing several types of the "Buda" industrial trucks. The illustrations feature a variety of purposes for which this truck can be used. Copies may be obtained from the Canadian Agents, the Federal Engineering Co., 92 Sherbourne St., Toronto.

Electric Welding by the "Winfield Way" is the title of an attractive bulletin issued by the Winfield Electric Welding Machine Co., Warren, Ohio. The bulletin describes the Winfield method of welding, also the Winfield electric welder, illustrating many types of machines, both spot and butt welders. An interesting feature of the bulletin is the large number of excellent half-tones showing the welder operating in a variety of plants thus demonstrating its wide field of application and utility. Some useful data on spot and butt welding are also included.

Fairbanks Hammers is the title of a catalogue issued by the United Hammer Co., Boston, Mass. The catalogue gives a general description and principal structural features of the Fairbanks hammer, and also illustrates the various types. Tables giving the sizes and details of motor-driven, countershaft-driven and regular pattern hammers are included while reference is made to the wide range of work for which this hammer is adapted. The concluding pages contain a schedule of foundation dimensions and an illustrated list of parts of power hammers.

BOOK REVIEW

Water Powers of Manitoba, Saskatchewan and Alberta, a well-bound and attractively illustrated volume, just

issued by the Commission of Conservation, forms a valuable contribution to the authentic literature respecting the natural resources of Western Canada. This report, by Leo G. Denis and J. B. Chalkies, comprises the results of special surveys by the Commission of Conservation and a compilation of records from other reliable sources. As a compendium of all available data on the subject, it is particularly valuable for reference purposes. While the Prairie Provinces, as a whole, are not lavishly endowed with water powers, the report demonstrates that the utility of their rivers for power development can be vastly enhanced through proper storage of flood waters. At present, in the absence of conservation dams, and of adequate natural regulation, the great volume of flow is lost during high water seasons. Methods of development to ensure the maximum utilization are now being carefully worked out on the Winnipeg, Bow and other large rivers. The more northerly regions possess numerous sites of great potential value for pulp, electro-chemical and other special industries. The report just issued is the second in the series on water powers in Canada to be published by the Commission of Conservation. The third volume, "Water Powers of British Columbia," which is now in press, will complete the Commission's general inventory of this item of the Dominion's natural wealth.

Subsidence Resulting From Mining, published by the Engineering Experiment Station of the University of Illinois.—As a result of underground excavation which is made in the process of mining, the earth's surface frequently subsides to an extent which interferes with the stability of buildings, railroads and other facilities which may exist on the surface. Where subsidence is occurring or in the immediate future is likely to occur, building projects on the surface must take account of these facts. The comparative newness of most of our mines is probably responsible for the fact that the subject only recently has attracted widespread attention. The subject is one which has recently been studied by the Engineering Experiment Station of the University of Illinois in co-operation with the State Geological Survey and the United States Bureau of Mines. The investigators, Professor L. E. Young and Professor H. H. Stock, have summarized existing facts as presented by the literature on the subject, have conducted an extensive correspondence with mine operators and mine workers throughout the coal mining districts of the United States, and have studied local conditions as they now exist in the mining districts of Western Pennsylvania, West Virginia, Maryland, and Illinois. The results of these investigations are presented in Bulletin No. 91 of the Engineering Experiment Station, a book of 200 pages, well illustrated. Copies may be obtained gratis upon request from W. F. M. Goss, director, Urbana, Ill.

CANADIAN MACHINERY AND MANUFACTURING NEWS

A weekly newspaper devoted to the machinery and manufacturing interests.

Vol. XVII.

TORONTO, MARCH 15, 1917

No. 11

EDITORIAL CONTENTS

Shell Production in a Plant Equipped for Post-War Effort	251-254
General	254
Locomotives for Canadian Government Railways.	
Production Methods and Devices	255-256
Friction Clutch for Countershaft . . . Shell Making Troubles . . . Rapid Capstan Lathe Work.	
General	256
Swedish Trading Licenses.	
Steel Industry Developments	257-259
General	259
British Shell Contracts in United States . . . Semi-Precision Grinding . . . Aluminum Fuse Making Troubles.	
High Pressure Steam Stop Valve Design and Construction	260-263
General	263
Cunard Ships in U.S. Yards . . . Empire Zinc Output . . . India Buying Steel in United States . . . Canadian Government Railways.	
Editorial Correspondence	264-265
Machinists' Instruction Course—XV . . . Belt Trouble . . . Foundry Tumbling Barrel.	
Spokes in Industry's Wheel	266
William Martin McRobert.	
Progress in New Equipment	267-270
Pump Valve Reseating Machines . . . Conveyor Type Automatic Heating Furnace . . . Water-Sealed Rotary Pump . . . Automatic Temperature Control . . . High Speed Bench Drilling Machine . . . Tapping Machine.	
Editorial	271
Activities of Imperial Munitions Board to Include Shipbuilding.	
Selected Market Quotations	272-273
The General Market Condition and Tendency	273-276
Summary . . . Montreal Letter . . . Toronto Letter.	
Industrial and Construction News	277-278

THE MACLEAN PUBLISHING COMPANY, LIMITED

JOHN BAYNE MACLEAN, Pres. H. T. HUNTER, Vice-pres. H. V. TYRRELL, Gen. Man.

Publishers of Hardware and Metal, The Financial Post, MacLean's Magazine, Farmer's Magazine, Canadian Grocer, Dry Goods Review, Men's Wear Review, Printer and Publisher, Bookseller and Stationer, Canadian Machinery and Manufacturing News, The Power House, The Sanitary Engineer, Canadian Foundryman, Marine Engineering of Canada.

Cable Address: Macpubco, Toronto; Atabek, London, Eng.

ESTABLISHED 1887.

CANADIAN MACHINERY AND MANUFACTURING NEWS

PETER BAIN, M.E., Editor. B. G. NEWTON, Manager.
Associate Editors: A. G. WEBSTER, J. M. WILSON, J. H. RODGERS.

CHIEF OFFICES:

CANADA—Montreal, 701-702 Eastern Townships Building; Toronto, 143-153 University Ave., Telephone Main 7324; Winnipeg, 22 Royal Bank Building, Telephone Garry 2313.

GREAT BRITAIN—LONDON, The MacLean Company of Great Britain, Limited, 88 Fleet Street, E.C., E. J. Dodd, Director. Telephone Central 12900 Cable Address: Atabek, London, England.

UNITED STATES—New York, R. B. Huestis, 115 Broadway, N.Y., Telephone Rector 8971; Boston, C. L. Morton, Room 733, Old South Building, Telephone Main 1204. A. H. Byrne, 11015-6-7 Fort Dearborn Bldg., 105 W. Monroe St., Chicago, Telephone Randolph 3234.

SUBSCRIPTION PRICE—Canada, Great Britain, South Africa and the West Indies, \$3.00 a year; United States, \$3.50 a year; other countries, \$4.00 a year; Single Copies, 15 cents Invariably in advance.

Hendey Millers will take any kind of a miller job

that comes into the modern shop

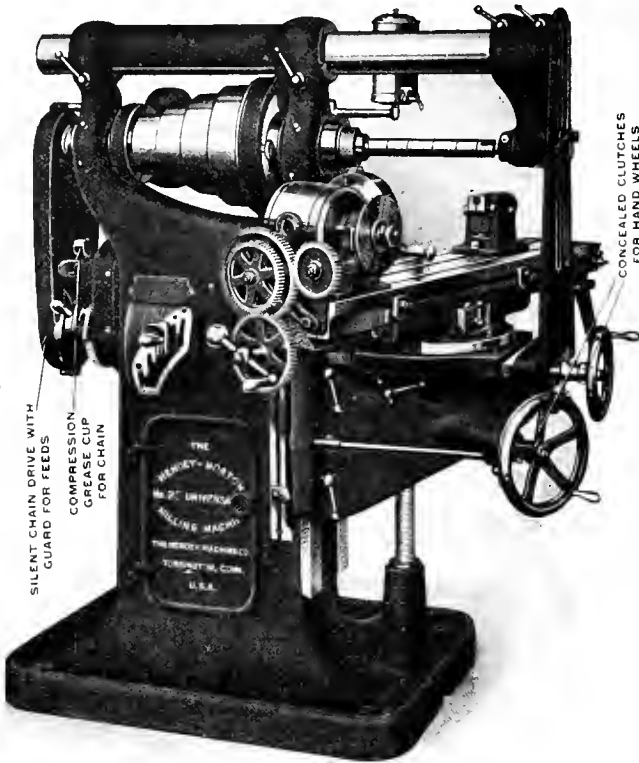

and it delivers the finished work in the highest degree of accuracy and perfection. It has a wide range of spindle speeds (16) and feeds (18).

The "Hendey" is free from the usual complicated features. All working positions are secured with but few and easily understood movements on the part of the operator. Anyone can operate the "Hendey Miller." No special skill is required to get the service that the Hendey's built for.

Write for the "Hendey Miller" Book. It is certain to interest you.

The Hendey Machine Co.
Torrington, Conn., U.S.A.

Canadian Agents: A. R. Williams Machinery Co., Toronto, Ont.; A. R. Williams Machinery Co., 260 Princess St., Winnipeg; A. R. Williams Machinery Co., Vancouver; A. R. Williams Machinery Co., St. John, N.B.; Williams & Wilson, Montreal.

INDEX TO ADVERTISERS

A	Albany Pump Co. 64	Davis, W. F., Machine Tool Co. ... 73	DeLoro Smelting & Refining Co. ... 70	Drury, H. A., Co. 7	De Mooy Mach. Co. 80	Dept. of Finance 85	Dominion Mch. Co. 70	Dominion Steel Pdy. Co. 96
B	B.A.B. Model Mfg. Co. 69	Eastern Machine Snow Corp. 91	Elmes Eng. Works, Charles F. 92	Eric Foundry Co. 105	F	Fairley-Davidson Steel Co. 8	Fartherstungh & Co. 64	Fitzgerald, W. H. J. 71
Baird Machine Co. 98	Banfield, E. J. 16	Banfield & Sons, W. H. 65	Bames, Wallace, Co. 66	Baxter & Co., J. R. 15	Bertram, John, & Sons Co. 1	Blake & Johnson Co., The 101	Blount Co., J. G. 15	Bramford Oven & Rack Co. 67
Bristol Co. 76	Brownell Machy. Co. 95	Brown's Copper & Brass Rolling Mills, Ltd. 25	Budden, Handlany A. 64	C	Canada Machinery Corp. 77	Canada Metal Co. 4	Can. S. K. F. Co. 86	Canada Sales Co. 86
Can. Bond Hanger & Comping Co. 89	Can. Desmond-Stephan Mfg. Co. 77	Can. Economic Lubricant Co. 89	Can. Fairbanks-Morse Co. 80	Can. Ingersoll-Rand 30	Can. Inspection & Testing Laboratories, Ltd. 35	Can. Matthews Gravity Co. 67	Can. B. K. Morton Co. 101	Can. Merchand. Mfg. Co. 7
Can. Steel Foundries, Ltd. 109	Carlyle Johnson Mach. Co. 83	Carter Welding Co. 80	Chapman Double Ball Bearing Co. 88	Cincinnati Pulley Mach. Co. 74	Cincinnati Iron & Steel Co. 20	Cleveland Twist Drill Co. 101	Cleveland Pneumatic Tool Co. 31	Clipper Belt Lacer Co. 86
Cook, Asa S., Co. 92	Corbet Pdry. & Mach. Co. 21	Cullen Mch. Co., C. E. 71	Cummings, J. W. 165	Cushman Chuck Co. 95	D	Davis-Bonnonville Co. 96	Davis, W. F., Machine Tool Co. ... 73	DeLoro Smelting & Refining Co. ... 70
Davy-Bonnonville Co. 96	Davis, W. F., Machine Tool Co. ... 73	DeLoro Smelting & Refining Co. ... 70	Drury, H. A., Co. 7	De Mooy Mach. Co. 80	Dept. of Finance 85	Dominion Mch. Co. 70	Dominion Steel Pdy. Co. 96	Eastern Machine Snow Corp. 91
Elmes Eng. Works, Charles F. 92	Eric Foundry Co. 105	F	Fairley-Davidson Steel Co. 8	Fartherstungh & Co. 64	Fitzgerald, W. H. J. 71	Foss & Hill Machy. Co. Inside back cover	Francis & Co. 97	G
Gardner Machine Co. 111	Garlock-Walker Machy. Co. 18	Garvin Machine Co. 26	Geometric Tool Co. 63	Gilbert & Barker Mfg. Co. 82	Gibb Instrument Co. 85	Grant Gear Works, Inc. 96	Grant Mfg. & Machine Co. 27	Greenfield Mach. Co. 97
H	Hamilton Mach. Tool Co. 23	Hamilton Gear & Machine Co. 88	Hanna & Co., M. A. 9	Hawkridge Brothers Co. 66	Hendey Machine Co. 116	Hepburn, John T., Ltd. 17	High Speed Hammer Co. 27	Himoff Mach. Co. 96
Hollander Machy. Co. 69	Hoyt Metal Co. 98	Hull Iron & Steel Foundries 105	Hurlbut-Rogers Machy. Co. 97	Hyde Engineering Works 69, 93	Hungerford Brass & Copper Co. ... 24	I	Ideal Tool & Mfg. Co. 91	Independent Pneumatic Tool Co. ... 31
Iron Works, The 65	J	Jacobs Mfg. Co. 89	Jones Machine Co. 9	Jersey City Machine Co. 97	Jones & Glasco 86	Johnson Mach. Co., Carlyle 87	K	Kaselit, Ltd. 15
Kenney, Wm. & Sons 18	King, Ltd., Warden 11	L	L'Air Liquide Society 117	Lancashire Dynamo Co. 32	Landis Machine Co. 95	M	MacKinnon, Holmes & Co. 65	Manufacturers Equipment Co. 92
Mansh & Henthorn 11	Mathews, Jas. H., Co. 97	McCabe, J. J. 72	McCoy-Brandt Machy. Co. 71	McDonald Co., R. Inside back cover	McKay Co., James 28	McLaren Belting Co., J. C. 96	Mechanical Engineering Co. 85	Metalwood Mfg. Co. 78
Milton Mfg. Co. 74, 75	Miller-Smythe Elec. Co. 69	Milbolland Mach. Co. 26	Modern Tool Co. 26	Monarch Brass Mfg. Co. 28	Montreal General Tool Co. 20	Montreal Machy. & Supplies, Ltd. ... 78	Morse Twist Drill Co. 101	Morton Mfg. Co. 67
Murehey Machine & Tool Co. 93	N	National Machine Tool Co. 98	New York Machy. Exchange 70	Nicholson File Co. Front cover	Niles-Bement-Pond, Inside front cover	Northern Crane Works 95	Norton, A. O. 32	Norton Company 32
Nora Scotia Steel & Coal 12	O	Oliver Machinery Co. 27	Ontario Specialties, Limited 98	Oven Equipment & Mfg. Co. 91	P	Parmenter & Bulloch Co. 98	Peerless Mach. Co. 83	Perrin, Wm. R. 89
Petrie, H. W. 69	Positive Clutch & Pulley Works ... 96	Praet & Whitney Co. Inside front cover	Pingle, R. E. T. 27	Puro Sanitary Drinking Fountain Co. 65	R	Racine Tool & Machine Co. 83	Reed-Prentice Co. 33	Rhodes Mfg. Co. 29
Ridout & Maybee 60	Rivett Lathe & Grinder Co. 111	Riverside Mach. Co. 71	Robertson Mach. & Pdy. Co. 67	Rockwell Co., W. S. 96	Rockefson Mach. & Tool Co. 19	Roper, C. F., Co. 81	S	Scott Mach., G. H. 24
Shuster Co., F. B. 97	Simmons Mach. Co. 109	Skinner Chuck Co. 95	Slocum, Avram & Slocum 109	Smalley-General Co., Inc. 82	Standard Alloys Steel Co. 8	Starrett Co., L. S. 81	Steel Bending Brake Works, Ltd. ... 96	Steel Co. of Canada 3
Steeple Co., John 15	Stocker-Rumely-Wachs Co. 73	Stow Mfg. Co. 39	Swedish Steel & Importing Co. 9	Symington Co., T. H. 70 and 94	T	Tabor Mfg. Co. 98	Taylor Instrument Co. 85	T. C. M. Mfg. Co. 22
Toomey Inc., Frank 70	Toronto Iron Works 95	Toronto Testing Laboratory 98	Toronto Type Foundry 79	U	United States Electrical Tool Co. ... 31	V	Vanadium-Alloy Steel Co. 12	Victor Tool Co. 92
Vulcan Crucible Steel Co. 78	W	Walls, T. W. 107	Walcott Lathe Co. 28	Warner & Swasey Co. 21	Welbome & Co. 96	Whipple & Coate 23	Whiting Foundry Equipment Co. 81	Whitman & Barnes Mfg. Co. 113
Whitney Mfg. Co. 24	Wicks Brothers 16	Williams, J. H. & Co. 32	Williams Machy & Co., A. R. 63	Winsdor Mach. Co. 77	Winnipeg Gear & Engr. Co. 95	Z	Zenith Coal & Steel Products 96	Zin-Ho Mfg. Co. 30

Shell Production in a Plant Equipped for Post-War Effort

Staff Article

Much interest attaches to the efforts by means of which our manufacturers hope to maintain, to a considerable degree, the position which the Dominion has attained in the realm of engineering accomplishment. That opportunities await the progressive manufacturer in the near future is generally admitted, and the plant described herewith is one instance where a high degree of preparation has been made for future developments, limited only by the exigencies of present production requirements.

MACHINING MARK VII. 4.5 IN. H.E. SHELL

THE numerous plants engaged in manufacturing munitions throughout the Dominion may be roughly divided into three classes, viz., plants existing previous to the war, plants built specially for shell production with little or no intention of future utilization, and plants built for meantime shell production, but with definite intentions of utilization in certain future activities.

The plant described in this article belongs to the last named class, and is of particular interest at this time as being concrete evidence of the thorough and discriminating manner in which certain of our manufacturers are preparing for peace while engaged in supporting the Arms of Empire. Readers familiar with machine shop equipment and practice will be quick to appreciate the keen perception and sound judgment displayed by the executives of this plant in the selection of its present equipment.

All of the machines necessary for the production of 4.5 in. howitzer shells have been obtained from makers of repute, are of standard design and quality, and are tooled up so as to interfere as little as possible with their future employment on regular machine shop work. The types of machine adopted are such that with very few additional ones the scope of work which can be undertaken in the plant will be greatly widened, and the opportunities for profitable employ-

ment in post-war days correspondingly increased.

Building Lay-out

Considerable interest centres in the building, which is of the T design, combining simplicity and convenience of arrangement with efficiency in lighting, heating and shop administration. Fig. 1 is an exterior view of the building, and Fig. 2 a plan. Seven saw-tooth roof lights provide an ample supply of north

throughout, being supplied by a Kewanee horizontal fire-box type of boiler. High efficiency and great economy of space are obtained by the use of pressed steel

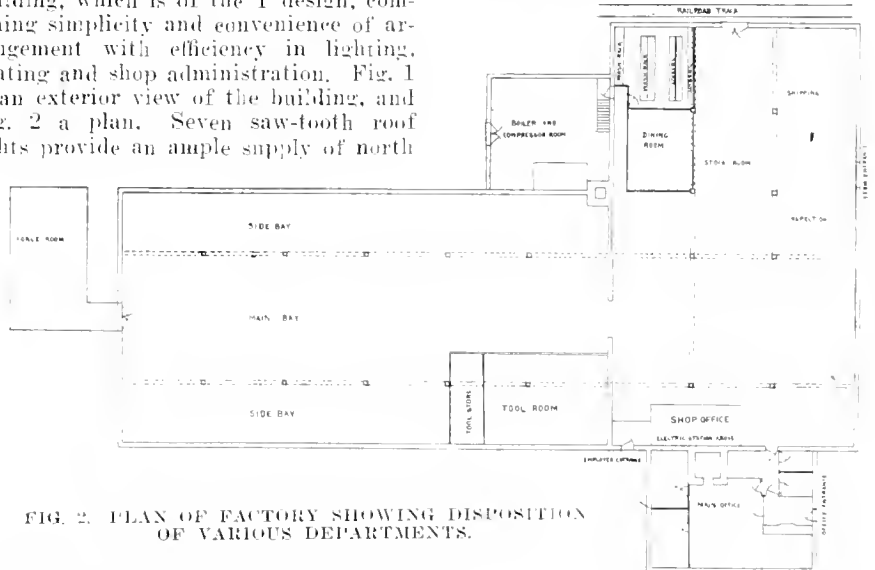

FIG. 2. PLAN OF FACTORY SHOWING DISPOSITION OF VARIOUS DEPARTMENTS.

light, supplemented by liberal sidelights, the latter being of Henry Hope sash with tilting centre sections for ventilation in warm weather; each saw-tooth section is provided with two ventilators of the positive exhaust, swivelling cowl type.

At the present season of the year the heating arrangements are much in evidence. Steam heating is adopted

radiators, which are mounted on the walls below each window, but well clear of the floor, so as not to favor the accumulation of dust, scrap articles and other refuse.

The building is 181½ ft. long over all, with a width of 64 ft. in the machine shop, and 105 ft. over the receiving, shipping, and stock rooms. A two-storey office building, 42 ft. by 30 ft., extends



FIG. 1. EXTERIOR OF FACTORY SHOWING SAW-TOOTH ROOF, EXTENSIVE SIDELIGHT PROVISION, AND OFFICE BUILDING.

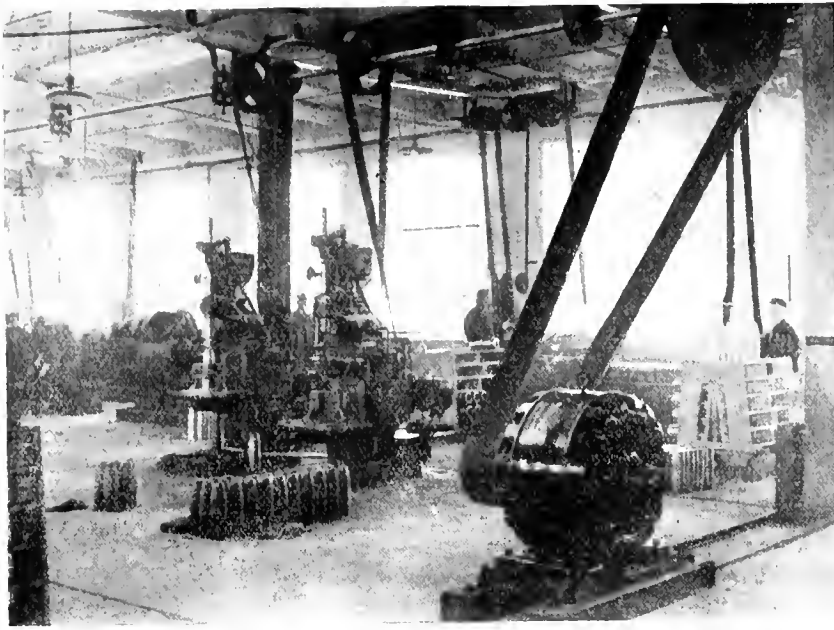

FIG. 3. VIEW OF SIDE BAY SHOWING BALL-BEARING SHAFTING, DRILLS AND AUTOMATIC TURRET LATHES.

across one end of the latter department. The upper floor is occupied by the drafting room, blueprint department, and superintendent's office; while the ground floor provides accommodation for main office, and two private offices. A fire-proof vault provides safety deposit facilities for records, etc., on each floor.

Power Supply

Electric power from a supply company is used throughout, while compressed air is supplied from a motor-driven Curtis 9 in. x 9 in. vertical two-cylinder compressor, this service being at present utilized in various ways in the shell work. An idea of the interior arrangements of the machine shop can be obtained from Figs. 3 and 12. Main line shafting extends along either side of the main bay—one 118 ft. x 3 in.; one 80 ft. x 3 in., and 18 ft. x 2½ in., carried

in S.K.F. self-aligning ball bearings, and driven by 40, 10, and 7½ horse-power motors respectively.

Incandescent electric lighting is used throughout, nitrogen lamps of suitable power being used wherever suitable, supplemented by high efficiency reflectors. All of the wiring is enclosed in metal conduits and the central control station is next to the office (see plan), the switchboard being located on a mezzanine gallery above the shop office. The employees' entrance is situated here, with time-recording clock and barrier grill, the latter arranged so as to provide suitable space for parties whose business does not require them to enter the shop proper. Team entrance and railroad track are provided for handling goods directly on to floor of shipping room.

In this part of the building are also provided locker accommodation and dining room, hot water, individual metal lockers, and comfortable restaurant equipment.

Tool Room

Tool room equipment for handling shell work must be capable of dealing with a higher proportion of cutters and other heat treated parts than usually obtains in the ordinary run of jig and fixture work, lathes, drills, shapers, and grinders being perhaps the essential tools required. A corner of the tool room is shown in Fig. 4, prominent items of equipment being a Potter & Johnston universal tool-room shaper, a single-spindle Henry & Wright sensitive drill, and two Hoskins electric furnaces. Remaining items in the tool-room include a haek saw machine, a McDougall 10-in. vertical drill, one McDougall 16-in., one Hamilton 14-in., and one American 14-in. tool-room lathes, one LeBlond tool-room grinder, one drill grinder, and several individual benches, with Parker universal vises. The tool crib is liberally provided with steel shelving of suitable design.

Shell Manufacture

No effort has been made to originate special machining methods, the underlying principle being to obtain a maximum output of good work, while maintaining the machines in a high state of general efficiency and ultimate adaptability to special or general machine work. With this object in view, such work as equipping LeBlond engine lathes for rough turning was done with practically no material alteration to the machine itself, all special tool-holders, profile bars, counterweights, etc., being attached by elamps, so that only one ⅝-in. tapped hole has had to be drilled to attach the fixtures.

The initial operation of roughing out the bottom is done in a Barnes all-gear-ed drilling machine, the metal being removed to a point where soundness of material is assured. With this as a starting point, the base is cut off and the month trimmed in cutting-off machines of the Williams type, and the base is then centred on a small special machine constructed of an old 16-in. lathe bed. The chuck holding the centre drill is mounted on a spindle with screw feed, carried on a hinged member, which swings up and back, allowing the forging to be conveniently removed from the driving arbor on which it is supported.

Illustration, Fig. 5, shows the forging being rough turned on a 21-in. heavy duty LeBlond lathe. These and several other machines have been fitted with air chucks by the Manufacturers' Equipment Co., the rapid handling, due to this device, having enabled considerably increased output to be obtained. The shell is roughed to the dimensions in sketch, Fig. 6, and is then bored out on similar machines fitted with the maker's standard type of turret carriage.

Three tools accomplish this work, a single point boring bar, a bottom roughing enter, and a finishing reamer for

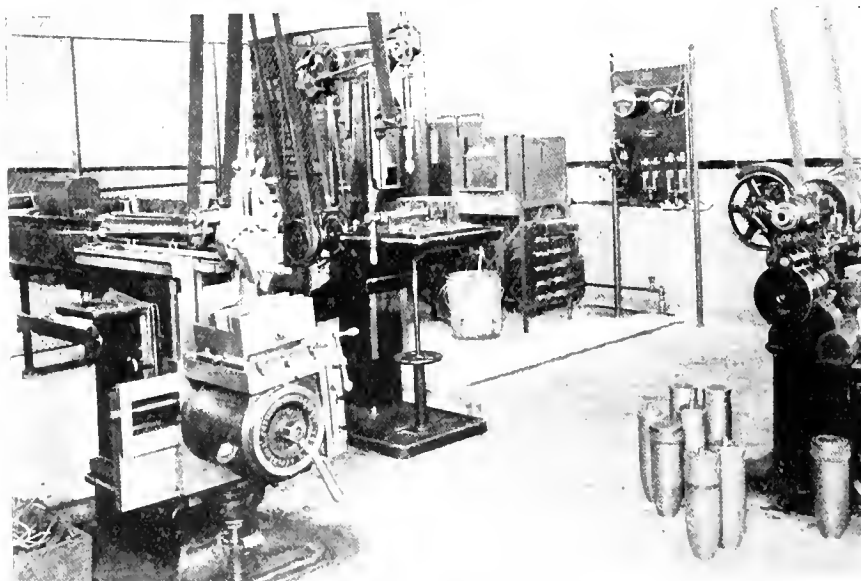

FIG. 4. A CORNER OF THE TOOL ROOM. UNIVERSAL SHAPER AT THE LEFT WITH ELECTRIC FURNACE INSTALLATION IN THE BACKGROUND.

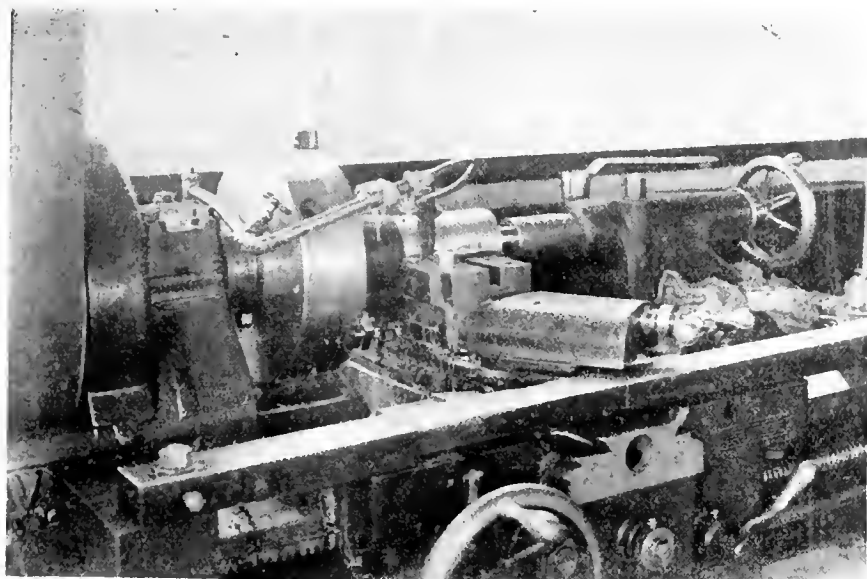

FIG. 5. ROUGH TURNING FORGINGS ON A "LEBLOND" HEAVY DUTY LATHE WITH DETACHABLE PROFILING BAR.

bore and bottom. During the latter part of this operation a bevel is turned on the outside of the mouth in accordance with nosing requirements. Fig. 7 shows the type of spade tool used, the cutting edges being of unequal length to insure a clean surface in the centre.

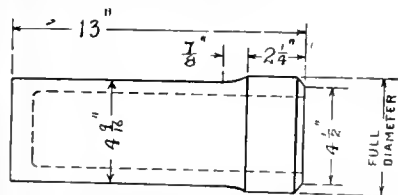

FIG. 6. DIMENSIONS OF FORGING READY FOR NOSING-IN HAMMER.

Forging the Nose

Excellent results are obtained through the use of a Beaudry power hammer, which is provided with suitable forging dies and a chuck for holding the forging by the base (see Fig. 8). This chuck is arranged to feed forward while the work revolves, the forged nose being accurately centred and possessing ample metal for subsequent finishing, both inside and outside. The Frankfort furnace installation is complete with oil pump, blower, etc., and has capacity for heating seven shells simultaneously. A



FIG. 7. SPADE TOOL FOR FINISHING INSIDE OF BASE.

10 horse-power Lincoln motor operates this department, which is housed in a separate structure at the end of the machine shop. Apart from the fact that satisfactory results are obtainable by any of the various methods of nosing-in, the adoption of the power hammer method would appear preferable in this case because of its ultimate sphere of usefulness in ordinary shop work.

In this department are also installed

two tanks with lye solution and hot water for washing purposes, provision for heating in summer time being made through a 22 in. x 4 ft. 6 in. vertical boiler.

A battery of Potter & Johnson 6 A automatic machines equipped with Lincoln individual motor drive takes care of the finishing operations on the nose and the recessing of the base. In the former operation, the shell is held in air chucks of the type previously mentioned, which grip the body of the shell over a length sufficient to insure accurate location of the nose, which is now bored to size, recessed, reamed and beveled.

Body Finishing

The design of dies used in forging, combined with the proper allowance of metal result in a minimum of stock to be removed in the final turning of the entire outside. A 16 in. Stevens lathe

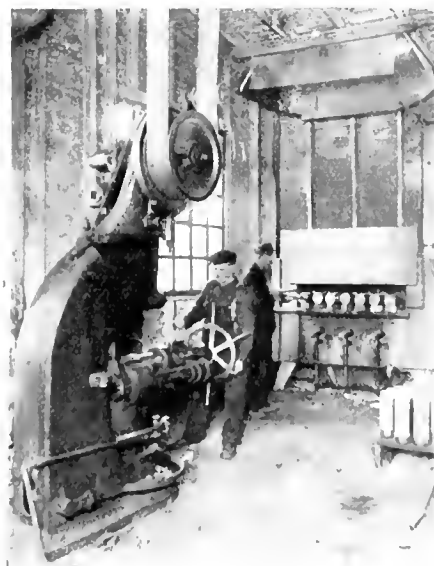

FIG. 8. BEAUDRY POWER HAMMER AND FRANKFORT OIL-FIRED FURNACE HEATING AND FORGING THE SHELL NOSES

with parallel and radial tool boxes performs this work in good shape.

The carriage is provided with two separate tool boxes as shown in sketch plan Fig. 9. Each is adjustable individually while the perpendicularity of the radial link, and its points of swinging are adjusted by two sets of lock nuts at the back of the carriage. Tubular cutting tools enable a maximum cut to be taken with the required degree of finish on the surface while the peculiar shape of the tool allows the entire circular cutting edge to be utilized, giving five or six times the life of an ordinary tool between grindings.

After tapping the nose in vertical drilling machines with collapsible taps, the interior profile is finished or blended with the parallel bore, a LeBlond turret lathe with solid formed cutter bar making an excellent job. A number of the P. & J. automatics mentioned are tooled up for base recessing grooving and waving. The layout of the tools is shown in Figs. 10 and 11, which shows the completed shell ready for removal. The various stations of the turret are numbered in rotation, No. 4 having a spring-backed supporting bearing which

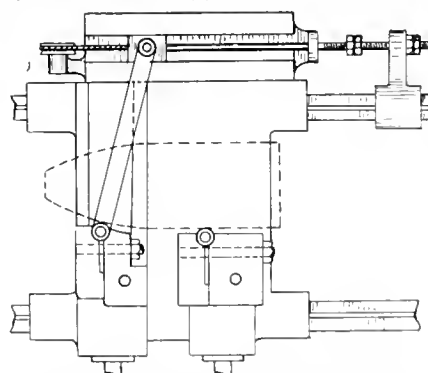

FIG. 9. PLAN OF LATHE CARRIAGE WITH TUBULAR TOOLS AND RADIAL LINK FOR GENERATING PROFILE CURVE.

takes the side thrust due to the grooving and waving tools.

Minor Operation

Following this in rapid rotation, the under cutting is done in a Rockafon band turning machine with diagonally sliding cutters, followed by washing, air blasting with steel shot in a Curtis outfit and complete inspection prior to notching the nose and riveting in the base plates. A High Speed Hammer Co.'s machine is used for the latter operation, the riveting ram being revolved by power while working insuring even wear on the point with uniform results from each blow and consequent ease of control.

The notching referred to is the three small grooves now required on the point of the nose, and a discarded thread milling machine provided ready means of doing this. A special cutter spindle was arranged transversely to suit the position of the grooves and three dividing holes provided on the back plate which holds the shell inside the hollow head-stock spindle. The shell nose contacts positively with a hardened plate on the cutter support insuring uniform results.

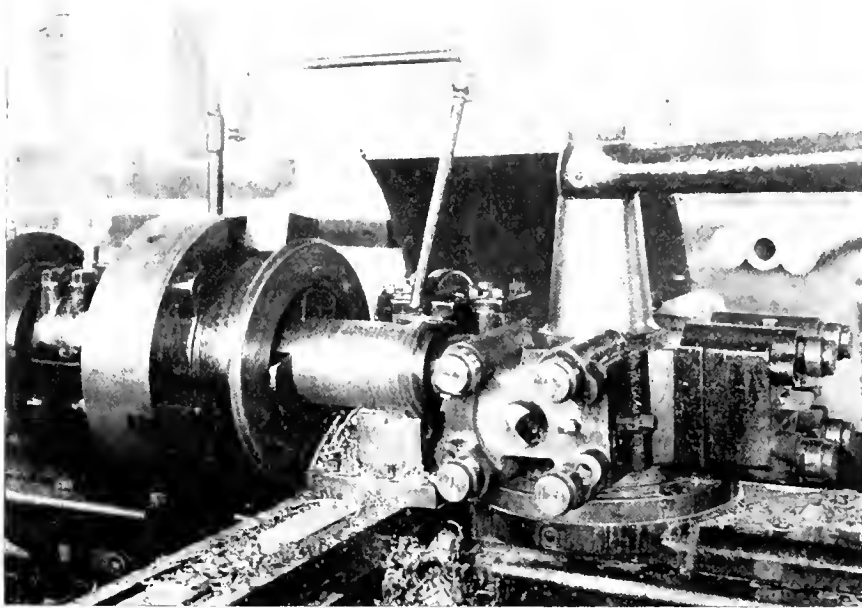

FIG. 10. VIEW OF "POTTER & JOHNSTON" AUTOMATIC WHICH RECESSES BASE AND MACHINES DRIVING BAND GROOVE COMPLETE AT ONE SETTING.

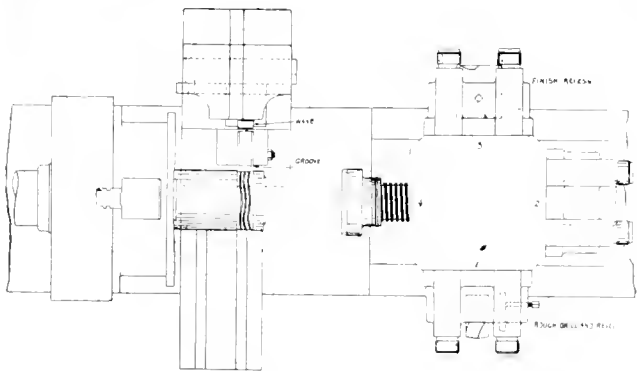

FIG. 11. LAYOUT OF TOOLS IN FIG. 10. SHELL IS SHOWN READY FOR REMOVAL.

Banding and Varnishing

After facing the bases, the bands are pressed on with a Goliath-McCulloch press operated by a Smart-Turner three-throw pump operating at 1500 lb. per sq. in. The turning of the band to the correct diameter and profile is done in a Roelofson band turning machine. A quick acting chuck, with two cutting tools and ample belt power enables one

machine to keep pace with the balance of the equipment, graduated feed dials and rigidity of tool supports giving desired accuracy in results. This equipment is shown in Fig. 12.

A further washing and inspection is now given before varnishing and baking, these latter being done in a dust-proof room. A Paasche air brush equipment has been installed for varnishing the interior surface. Air at 80 lbs. pressure is passed through a small electric heater on the wall, Fig. 13, and atomises a gravity supply of varnish, the mixture depositing a uniform film of varnish, free from bubbles, and with a small consumption of time and material. An electric oven with two trucks performs the baking, one truck filling while the other is heating.

Painting is performed by hand while the shell is revolved by power. Boxing and shipping which follow after, being performed under the supervision of government officials.

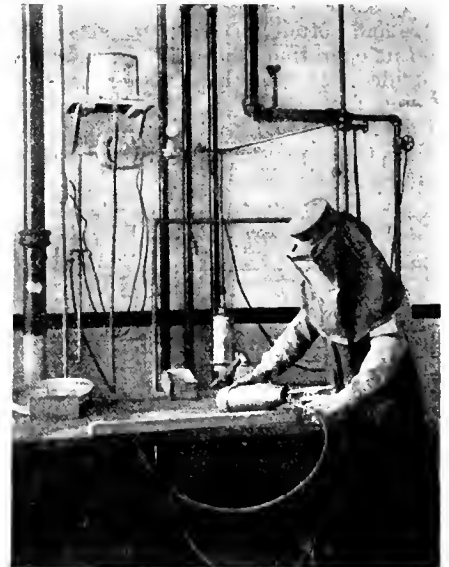

FIG. 13. PAASCHE AIR BRUSH EQUIPMENT FOR VARNISHING THE INTERIOR OF THE SHELLS.



FIG. 12. BANDING DEPARTMENT, SHOWING HYDRAULIC PRESS WITH "ROELOFSON" BAND TURNING MACHINE AT RIGHT.

LOCOMOTIVES FOR CANADIAN GOVERNMENT RAILWAYS

A CONTRACT for twenty more heavy Mikado freight locomotives for the Canadian Government Railways has been awarded by the Minister of Railways to the Canadian Locomotive Works, Kingston. Already the work is in such shape that the first engine is on its way to the Intercolonial Railway to help cope with the present heavy movement of freight to the seaboard. Deliveries have been completed by the Canadian Locomotive Works under an earlier order for thirty locomotives. These engines cost about \$39,000 apiece, or almost 100 per cent. more than pre-war prices. In addition, the department purchased 10 Santa Fe Moguls at \$36,468 in bond Montreal, and 28 second-hand locomotives from Transcontinental contractors. A total of 88 engines have thus been bought or ordered for the Government railways during the present fiscal year.

PRODUCTION METHODS AND DEVICES

A Department for the Interchange and Distribution of Shop and Office Data and Ideas Evolved from Actual Practical Application and Experience

FRICTION CLUTCH FOR COUNTER-SHAFT

by J. H. R.

THE matter of suitable drive for machine tools is an important factor not only in the production of munitions but in that of other manufactured articles as well. While recent applications of machine drives do not

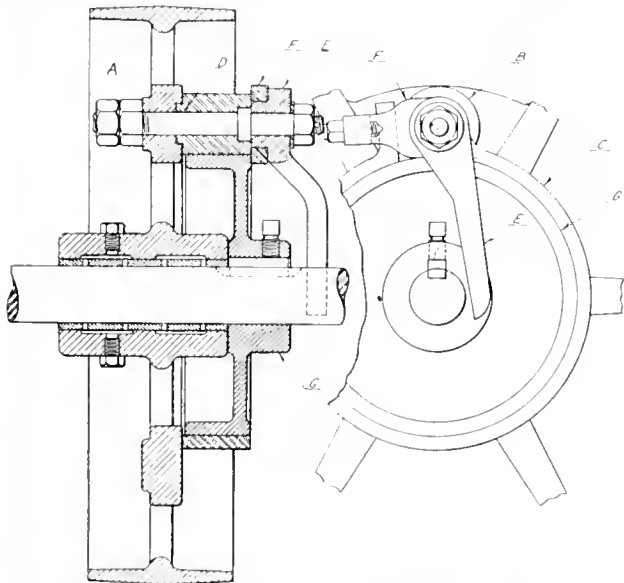

FRICTION CLUTCH FOR COUNTERSHAFT.

bear directly upon the munition problem, many of these have been developed to overcome difficulties arising out of this industry. The clutch here shown was designed and constructed by the John McDougall Caledonian Iron Works, Montreal, for the purpose of increasing the efficiency of shell turning lathes. Contrary to the general practice of an expanding spring clutch ring, the method adopted in this device has been to use a spring ring that closes on the outer diameter of the driving hub G. One end of the spring clutch ring C is secured firmly to the boss B of the loose pulley. The operating lever arm E, when forced outward by the slip sleeve (not shown), draws the two ends of the clutch ring C together, gripping the driving hub G. With the interior ring, there is generally a tendency for the clutch to creep, this being caused by the centrifugal action of the spring ring. With the type here shown, the motion, when clutch is out of action assists in preventing contact between the two friction surfaces.



SHELL MAKING TROUBLES

by R. O.

WHERE the percentage of defective shells in any munitions machinery plant is abnormally large, the cause may be attributable to the dullness of the cut-

ting tools employed in the several processes, a circumstance largely due to lack of appreciation on the part of operators of the degree of efficiency to which maintenance is essential to ensure both quality and quantity production.

Dull tools are also the source of more or less trouble and expense. A common result of dull cutting tools is shown at A in the sketch, where the tool is set at an oblique angle (in a forward direction), to the parallel travel of the tool. When roughing the outside of shell forgings, the variation in depth of cut is often considerable, resulting in variable strains being placed upon the tool itself, and also on the containing parts. This feature, alone or in combination with others, tends to force the cutting end of the tool in the direction of the arrow; if a keen edge be not maintained on the tool, or extreme hardness in the shell be encountered, resulting in rapid deterioration of the tool cutting qualities, a tendency to swing becomes at once obvious. If set at the angle shown, any shifting of the tool from above causes will result in a gradual reduction in diameter, or probably a groove as indicated. Whenever possible, tools should be set at right angles to the direction of the cut, so that any movement of the tool in its support, caused by excessive pressure, will reduce the depth of cut, forcing the tool to cut a larger diameter and thus avoid spoiling the work.

Similar conditions may result on the inside bore operation, but, owing to the different method of tooling, the effect is somewhat varied. When in a munitions plant some time ago, I was shown a 60 pdr. shell that had been cut lengthways through the centre to demonstrate a fault that had originated by reason of too much stock removed from the inner base, in addition, the dullness of one portion of cutter blade was contributory. The section of the cut shell showed an enlarged chamber at the base,

slightly greater in length than the forming blade and having a diameter about 1-32 inch larger than the main bore of the shell, as shown at D. Investigation proved that several shells had been rejected for this reason; and it was also discovered that the cutters used had a dull portion at the point C. Aided by the length of the boring bar and the poor cutting of the section C, the side thrust had the effect of enlarging the chamber as indicated.

I was shown a shell recently that had been cut to demonstrate the cause of its rejection, to wit, a defective base plate. This plate was of the threaded type and had been coated with cement and screwed in, the fit being apparently very snug. The cut shell showed that contact had not been made with the two surfaces as indicated at E. A reasonable cause of this was the inability of the trapped air to escape, the compression being so great as to prevent the direct contact of iron and iron. After this discovery, base plates were not permitted to be screwed in so tightly, the riveting process taking place after the plates had bottomed.



RAPID CAPSTAN LATHE WORK

Herbert's Monthly.

MANY firms who are now manufacturing the 6-in. high explosive shell, Mark IV., were previously working on the Mark XVI. shell, and the capstan lathes which had been installed for producing the heads of the latter shell were naturally changed over to the Mark IV. head when the transition took place. The Mark IV. head is, however, much larger than the Mark XVI. head, as will

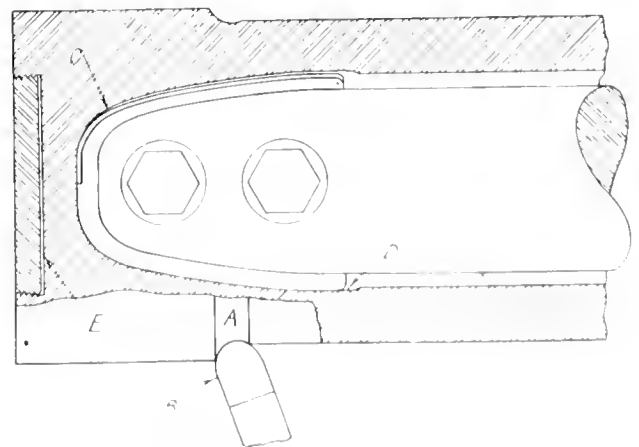

FEATURING SHELL MAKING TROUBLES

be seen from Fig. 1, and the additional duty on the capstan lathes was very considerable. The way in which capstan lathes are handling this work is a remarkable revelation of the reserve in

strength and power which these comparatively small machines possess, while the rate of output which is being obtained on the Mark IV. head is all that can be desired.

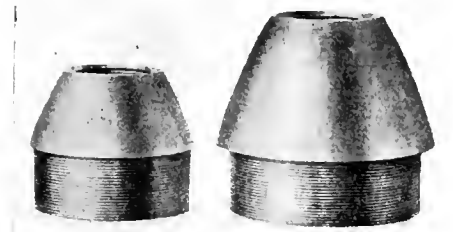

FIG. 1—MARK XVI, AND MARK IV. HIGH EXPLOSIVE SHELL HEADS.

In one works, the material for the head is in the form of blanks cut from mild steel bar; this form of material being found much more satisfactory to machine than forgings or pressings, which are usually scaly and not uniform in size. The lathe operations on blanks are three in number, two of which, namely, the first and third, are performed on No. 4 Capstan Lathes. The first operation is shown in Fig. 2, where the blanks are held by special jaws in a 12-in. Coventry chuck, the blanks being set back against the steady-bush in the chuck. The tools are numbered in the lay-out according to the sequence of operations, which is as follows:—

- 1.—A standard flat centring tool, which provides a true start for the drill.
- 2.—A Herbert patent straight flute

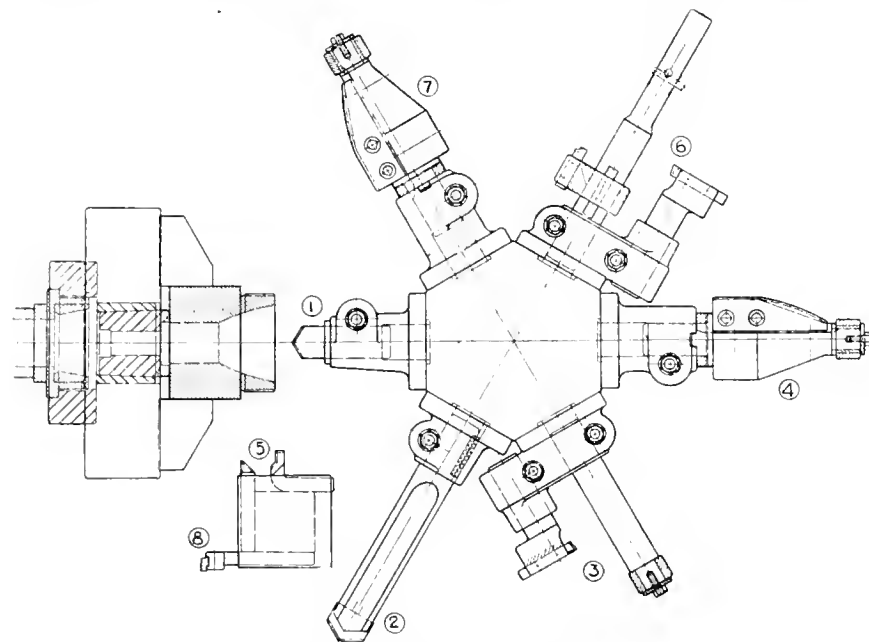

FIG. 2. TOOL LAYOUT FOR FIRST OPERATION.

drill, with inserted spiral cutter. The size used is 1 3/4-in.

3.—A standard knee-turning tool holder for rough turning the thread diameter, provided with a pilot bar which fits in the drilled hole. Although it would be possible to use a plain pilot bar fitting in the steady bush, the ar-

angement shown is the better one, inasmuch as it avoids undue wear on the steady bush.

4.—A single blade form counterboring tool, provided with a revolving pilot bush fitting in the drilled hole. Owing to the heavy cut, a driving collar is provided, which engages with a slot cut across the end of the boring bar holder.

5.—A facing and recessing tool for the shoulder and a chamfering tool for the end carried in the square turret. These operate simultaneously with 4.

6.—A standard knee-turning tool with cutter for finishing the thread diameter. It also carries a boring bar for finishing the 1.82-in. diameter, and for forming the radius at the mouth of the counterbore.

7.—A finish counterbore, identical with 4, except that the bush fits the finished bore.

8.—An inverted chaser holder for cutting the thread.

In some works, we have seen this op-

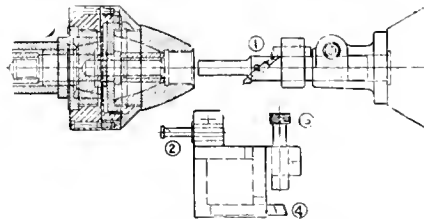

FIG. 3. TOOL LAYOUT FOR THIRD OPERATION.

eration performed in 15 minutes, and we are informed by the management that some of the girl operators have

note that the finishing cut is done with a Stellite cutter, the work running at a surface speed of 250-ft. per minute.

The lay-out for the third operation on a No. 4 Capstan Lathe is shown in Fig.

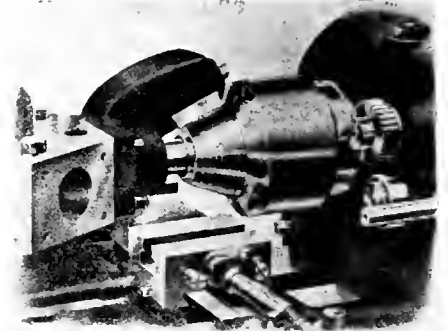

FIG. 4—HERBERT NO. 4 CAPSTAN LATHE ON THIRD OPERATION.

3, where the work is held by the external thread in a Herbert special drawback chuck. The tools are as follows:—

- 1.—A boring bar for opening out the thread diameter. It also carries a collar and cutter for rough forming the fuse seat.
- 2.—A circular cutter carried in the square turret, for forming the recess at the back of the thread.
- 3.—A circular internal chaser, by which the thread is cut to gauge without the use of sizing taps. The patent chasing saddle makes this operation an exceedingly rapid one.
- 4.—A finish form tool for the fuse seat, which is used in the square turret so as to ensure it being true and concentric with the chasing.

A time for this operation, taken in a number of plants with the foregoing equipment installed, was three minutes.

In some factories the Mark IV. head is being handled at two operations, the second and third being combined so that the external profile is formed on the No. 4 Capstan Lathe. The special tool for doing this part of the work is shown in Fig. 4.

SWEDISH TRADING LICENSES

WEEKS of valuable time continue to be wasted by representatives of American industrial firms because they or the concerns responsible for them have neglected to inform themselves about conditions governing the transit of wares across Sweden. There are few and negligible exceptions to the rule that everything destined for Russia requires a license before it can cross Sweden, and this rule applies as well to samples.

Licenses can be secured by the intervention of the British Legation at Stockholm, but the time required varies from four or five days to as much as three weeks. Canadian business men going to Russia with samples should forward to the Legation there a complete list of the articles, together with data establishing their identity as British citizens and setting forth the approximate date of their arrival. If this is done, the British Minister will have the transit licenses ready when the applicants arrive.

STEEL INDUSTRY DEVELOPMENTS

The War-Created Stimulus given the Steel Industry is Reflected alike in the Nature and Application of New and Improved Equipment being Installed and Developed.

UNIFLOW STEAM ENGINES FOR STEEL MILLS*

By W. Trinks.**

THE trend of power supply in iron and steel plants has been to electrify every machine, up to and including the main rolls, and to concentrate the power generating apparatus in a central power house containing steam turbines in regions of cheap fuel, and gas engines with an auxiliary steam turbine for overloads, in regions of expensive fuel. Into this evolution stepped the uniflow engine, which promises or threatens (depending upon the viewpoint), to change the march of events. The iron and steel plant electrical engineer is particularly interested in this problem because a change would deeply affect his work. For him the two following possibilities are of importance:

The uniflow engine may find a place in the works power plant, or else it may drive rolling mills directly, doing away with the double conversion of mechanical into electrical power in the central station and back again into mechanical at the mill. In Germany the uniflow engine has, in many places, been used for direct rolling-mill drive in preference to electrical drives. The question to be studied is, then, what has been accomplished on this continent in the development of this type of engine, and what is the outlook for the future?

Historical Features

The history of the uniflow engine begins in 1907. In that year Professor J. Stumpf, of Charlottenburg, Germany, made his designs and applied for patents. The characteristic part of the Stumpf engine, as is perhaps already well known, is the cylinder with steam admission at the ends, discharge in the center, and steam jacketed heads, as shown in Fig. 1. The idea of steam admission at the ends in combination with central discharge is old and was patented by Todd in England in 1885, but the fact that the idea remained wholly unused until Stumpf proved that it was useful when coupled with jacketed heads and a partly jacketed barrel, credits Stumpf as the inventor of the

uniflow engine from the viewpoint of the critical historian.

In 1907 Professor Stumpf clearly recognized the thermal advantages to be gained from the unidirectional flow of steam through the cylinder. In the summer of that year he fully explained his view upon the subject to the author of this paper at Charlottenburg, Germany. At that time the drawings of the experimental uniflow engines were well in hand. From 1907 to 1911 the evolution of that type of engine was limited practically to Austria and Germany. In 1911, Professor Stumpf published his well-known book on the uniflow engine, and bitter literary controversy on the merits or demerits of the Stumpf engine followed. In the same year American

engineers began to take notice of the Stumpf engine and, one by one, the C. & G. Cooper Co.; the Nordberg Mfg. Co.; the Mesta Machine Co.; the Skinner Engine Co.; and the Ames Iron Works took up the building of this type. A great deal had to be learned by these firms, and some of the experience was paid for quite dearly. At the present date, the period of experimenting is practically over, and the time is ripe for a review of the situation.

The principal claims for the uniflow engine are economy, simplicity, reliability and freedom from attendance. Let us consider these features in the order mentioned and then judge whether we can profitably use the Stumpf engine in our work.

In the steel works power plant this engine will have to compete with the gas engine and with the steam turbine. The gas engine was 7,500 to 9,000 British thermal units per indicated horse-power hour, whereas the uniflow engine, running condensing, uses from 11,000 to 13,500 British thermal units in the steam, and more in the fuel gas, depending upon the boiler efficiency. There is, in conse-

Steam Turbine Comparison

When we come to a comparison between the engine and the turbine, variation of steam pressure and of back pressure makes it advisable to leave the British thermal unit basis and to introduce Rankine cycle efficiency, which means the ratio of the work actually produced from unit weight of steam to the work which could be produced by the same weight of steam passing through the Rankine cycle. From a great number of published tests made on the very best turbines, the author has formed the following averages for condensing operation:

Size of turbine, kw.....	500	1,000	2,000	5,000	10,000
Rankine cycle efficiency	0.62	0.66	0.71	0.77	0.82
(Referred to brake h.p.)					

For non-condensing operation the values are much lower.

For the Stumpf engine, data furnished by the Stumpf Uniflow Engine Co., tests made by the author, and data from Ames Iron Works and from the Cooper Co., indicate the following efficiencies:

Size of engine, kilowatts.....	300	600
From 3 lbs. per sq. in., back pressure above atmosphere down to about 23 in. vacuum.		
Efficiency:		
Saturated	71	74
100 degrees superheat	75	77
200 degrees superheat	78	79
For high vacuum (about 27 1/2 in.):		
Saturated	58	62
100 degrees superheat	62	65
200 degrees superheat	66	68

The values may vary somewhat to one side or the other, but the general tendency is apparent. For non-condensing operation, at 100 degrees superheat, with moderate vacuum, and for sizes up to 1,000 kilowatts, the uniflow engine is more economical than the turbine. It will, therefore, find a place in comparatively small power plants, and in locations where 28 inches of vacuum or better is not obtainable. It will also be preferred for generating direct current, because turbines for the generation of direct current, when direct connected, are too slow for best economy. If they are to operate at economical speed, gears must be introduced.

Limited Field in Steel Works

Evidently, the uniflow engine will have a very limited field in the steel works power plant. Turning to the

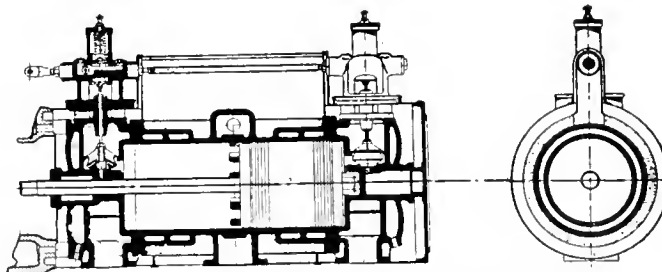

FIG. 1. LONGITUDINAL AND CROSS SECTIONS THROUGH STUMPF UNIFLOW ENGINE CYLINDER.

*From a paper presented at the 10th annual meeting of the Association of Iron and Steel Electrical Engineers.

**Professor of Mechanical Engineering, Carnegie Institute of Technology, Pittsburgh, Pa.

second application which interests us, namely, the driving of rolling mills, we find a changed condition. Let us for the sake of clearing up doubts, compare the uniflow engine with electric drive, and with older type of duoflow engine. In comparison with electric drive, the steam engine does away with the electric generator, the switch-board, the transmission line and the motor, but it takes undesirable piping into the mill. The elimination of the electrical part means that we must compare the Rankine cycle efficiency of the engine to the Rankine cycle efficiency of the turbine, including generator, transmission line and motor. Allowing the high efficiencies of 92 per cent. for the generator, 98 per cent. for transmission line and 92 per cent. for the motor, we must multiply the turbine efficiencies by 0.83 for comparison with the direct-connected engine.

This procedure furnishes the following:

Size of turbine, kw.	500	1,000	2,000	5,000	10,000
Rankine cycle efficiency:					
Referred to motor shaft	50	54	59	64	68
Referred to mill shaft..	47	50	55	60	64

The lower row of figures was obtained by multiplying the upper row by 0.965, this figure taking care of the efficiency of two speed reductions from the motor

ations in draft, temperature of steel, velocity of rolling, etc., cause disproportionately great changes in resistance. It is not possible to exactly foretell what the load will be, and it is therefore of the utmost importance to secure a drive which permits over or under-loading without serious change of economy. The uniflow engine, and the electric motor hitched to a large central station, both fill this requirement.

The old type simple duoflow engine, the old reliable standby of the rolling mill for over 50 years, cannot be considered here. It is so wasteful, that its low price is more than offset by increased cost of boiler house equipment, not to mention the continuous cost of fuel and water. It retained its place in the mill a long time, due to its simplicity, but was replaced here and there by the compound engine on account of its wastefulness. The uniflow engine combines the simplicity and overload capacity of the simple engine with the economy of the compound engine; it has the added advantages that its overload capacity is even greater than that of the simple engine and its economy is sustained over a greater range of load. Finally, it has very few moving parts and takes up much less floor space than the compound engine.

Variation in back pressure naturally affects the operation of the uniflow en-

gined by live steam and exhaust steam sweeping over them and wiping heat "on and off".

In the uniflow engine, only the piston head has been heat wiped off during the extremely short period of exhaust, the steam near the place of entrance of live steam being at rest like the fixed end of an expanding coiled spring during exhaust, and like that of a compression spring during compression. Besides, the cylinder head and part of the barrel are steam jacketed, and steam jacketed surfaces are cooled very little by stagnant steam. It may be remarked again that the mere provision of a central exhaust does not bring about a successful uniflow engine; the steam jacketing of the heads and of part of the barrel must go with it, to produce the thermodynamic superiority over the duoflow engine.

In the duoflow engine, long compression means increased steam consumption, principally, because the steam temperature exceeds the cylinder (or piston) wall temperature a longer time than it would with shorter compression. In the Stumpf uniflow engine the steam which is being compressed is in contact with progressively hotter surfaces, with the exception of that of the piston, and the steam temperature never rises very much above the wall temperature.

The second reason for the economy of the uniflow engine lies in the enforced or compulsory tightness. Steam cannot leak from the live steam space to the exhaust. If the inlet valves are leaky to any extent, the compression rises so quickly that the inlet valves clatter and give notice to the engineer that something is wrong.

In comparing test data with calculation results, I have obtained very good results by using Heck's formula for the internal condensation or missing quantity, but I substitute instead of his constant C the value

$$C = \sqrt{\frac{^{\circ}\text{F. superheat}}{4,500}} \text{ for duoflow engines, and } 0.45 C = \sqrt{\frac{^{\circ}\text{F. superheat}}{10,000}}$$

for uniflow engines.

Uniflow Engine Economy

The development of the uniflow engine in the United States has been slow, probably because it did not fit into the general trend of changing from reciprocating to rotating machinery, and because it is of foreign origin. It began in a small way in 1912. The C & G. Cooper Co., Mount Vernon, O.; the Nordberg Co., Milwaukee, Wis., and the Mesta Machine Co., Pittsburgh, began almost simultaneously to build experimental engines. All three firms moved cautiously and equipped their engines with Corliss gear. All three found out that the Corliss releasing gear, in its usual form, is not ideal for the uniflow engine, because the cut-off is so short, because modern plants carry high pressure with superheat, and because the pressure drops so fast after

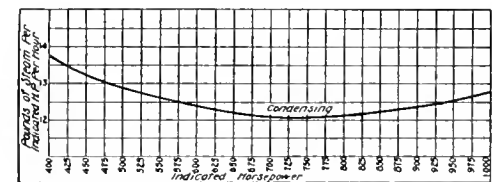

FIG. 2 WATER RATE LOAD CURVE OF ORDINARY COMPOUND ENGINE.

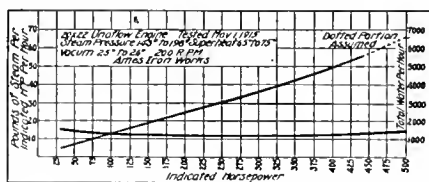

FIG. 3. WATER RATE LOAD CURVE OF UNIFLOW ENGINE.

to the mill. A study of the resulting values shows that the uniflow engine is ahead of the electric drive, unless the steel plant is so large that turbo units of over 8,000 kilowatts capacity can be installed.

The economy of the uniflow engine compared to that of the steam-turbine-electric drive, taken by itself, is not enough better to explain why the uniflow engine should fare differently from the compound engine. The Rankine cycle efficiency of a good compound engine is practically the same as that of the uniflow engine, but there is one difference. To obtain that high efficiency, the compound engine must have a small high pressure cylinder; but the small size of the latter means a small overload capacity, and quick departure from the best efficiency for comparatively small changes of load.

Compound Engine Comparison

Fig. 2 shows the water-rate-against-load curve for a well known compound engine. Comparison of this curve with the typical water rate curve of a uniflow engine, Fig. 3, shows the difference to be very marked. Mill loads are notoriously variable, because small vari-

ations in draft, temperature of steel, velocity of rolling, etc., cause disproportionately great changes in resistance. It is not possible to exactly foretell what the load will be, and it is therefore of the utmost importance to secure a drive which permits over or under-loading without serious change of economy. The uniflow engine, and the electric motor hitched to a large central station, both fill this requirement.

Uniflow Engine Development

A great deal has been written on the reasons for the economy of the uniflow engine; nevertheless the author will try to present the underlying facts again in as concise form as possible. The secret of the economy of the uniflow engine lies principally in reduction of internal cylinder condensation. In the duoflow single expansion engine, cylinder condensation is so great, that a very great free expansion loss must be allowed for best economy (or rather for minimum wastefulness). In the compound and triple expansion engine, cylinder condensation is reduced so that the free expansion loss can also be reduced, but mechanical losses due to the passing of the steam through so many valves becomes great. In the duoflow engine, cylinder head, cylinder barrel and piston head are alternately heated and

cut-off, that the valve becomes unbalanced too quickly for the ordinary design and size of vacuum pot. In consequence, the Mesta Co., and the Nordberg Co. switched over to poppet valve gears, while the Cooper Co. adapted its Corliss gear and vacuum pot to the new conditions.

The smaller sizes of uniflow engines have been developed by the Ames Iron Works, Oswego, N.Y., and by the Skinner Engine Co., Erie, Pa. The Ames Iron Works, from the very beginning, adopted poppet valve steam distribution, with shaft governor drive. This design is very well adapted for small engines up to 400 or 500 horsepower, and is very successful. For larger sizes and high steam temperature it is not so well adapted, because the difference in expansion between the valve rod and the cylinder becomes too great and disturbs steam distribution. For poppet valve engines above 500 horsepower the lay shaft drive is preferable.

In the sizes built by the Ames Iron Works, a self supporting piston, guided at the crank end only, is said to be satisfactory. In larger sizes this same design leads to a great deal of trouble. On account of difference in expansion, the piston must fit very loosely in the cylinder. The guiding of the piston by the crosshead is very imperfect. The piston, therefore, wobbles around in the cylinder, riding now on one spot, then on another, never wearing itself in, but rapidly wearing itself out. In large engines of German design, a tail rod guide has been provided, not so much for the purpose of carrying the piston, but mainly for the purpose of guiding it, so that it will always touch the cylinder in a large surface. American engineers have gone one step further and have made the piston rod strong enough to carry the piston.

Early Troubles

The early part of the practical development was thorny. Cracked cylinders, heads and bed plates caused trouble; valve gear troubles and regulation troubles had to be overcome, pistons and cylinders wore too rapidly; but the problems have all been solved and the future promises to be free from any obstacles whatsoever. Whatever troubles were experienced, naturally appeared more forcefully in the larger sizes, with the result that the smaller sizes, developed by the Ames Iron Works and the Skinner Engine Co., have made more progress in numbers than the larger sizes. It can safely be said that the uniflow engine to-day is as reliable as the simplest engine of the duoflow type. Additional steam consumption charts may be appreciated. To the scientific engineer they do not mean as much as Rankine cycle efficiencies, but habit has led many of us to think in pounds of steam per horsepower-hour. Consequently, Fig. 3 is given showing steam consumption of various types and sizes of uniflow engines.

BRITISH SHELL CONTRACTS IN UNITED STATES

REGARDING the reports that munition makers in the United States had been notified by the British Government that all contracts for the manufacture of shrapnel and other shells must be completed by March 31, and that on that date all contracts in existence for these war materials will lapse, an interest who has been in touch with the various orders placed in that country discusses the matter as follows:—"The foregoing statement is untrue. It applies only to such contracts as were originally scheduled for completion by the date mentioned. In this case, contracts will lapse, but this is nothing particularly new, because there have been several cancellations of arrearages on deliveries up to the present time. Contracts that were placed originally with a longer period of leeway for deliveries than March 31 next will be permitted to remain as per agreement and be carried out in accordance with stipulations."

It will be recalled that earlier in the current year it was announced that a number of contracts had been cancelled, but it developed that in each instance a cancellation clause was contained in the agreement. Much of this also was for materials in arrears; that is to say, companies which had agreed to deliver a certain number of shells by a given date, and having delivered only a part, were notified to cancel the balance that should have been shipped up to the time specified.

SEMI-PRECISION GRINDING

RAILROAD frogs, switches, crossovers, safes, large pinions and gears, dredge buckets and so forth, composed of alloy steels, usually manganese steel, are machined on boring mills, planers, shapers and sometimes on lathes by means of grinding wheels. A considerable amount of leeway in the finished dimensions is permissible, in some cases as much as one-quarter inch. The name "semi-precision" is applied to this class of operations.

When a piece is ground in a boring mill, it is firmly clamped to a horizontal revolving table and the grinding wheel is brought in contact, either on the outside or the inside of the casting. A motor is placed on top of the vertical crossrail in such manner that the armature of the motor is in a vertical position. The armature of the motor is extended so that at the bottom end of the vertical crossrail it becomes the spindle for the grinding wheel.

Operations of this nature are performed on a planer by attaching a portable electric grinding machine to the crossrail. Special types of planers are in use, notably the open-side type planer used for surface-frogs and switches. Here, the grinding wheel spindle is belt driven from an individual motor, located above and at the rear of the head which carries the spindle, because it is not convenient to have the wheel spindle direct-

ly connected to the armature of the motor.

When a shaper is used for semi-precision grinding, a suitable attachment is clamped to the front end of the ram, the attachment consisting of grinding wheel spindle mounted in proper bearings. The wheel is used on the bottom end of the spindle, which is driven by means of a belt operating over a pulley located at the top end of the spindle. The motor is located on a bracket situated above the back end of the ram. This arrangement makes necessary the use of a cup wheel. Quite a common operation to be performed in this manner is the surfacing of pin slots in large manganese steel dredge buckets.

The use of the lathe for semi-precision grinding is limited almost entirely to special shape castings which have either a cylindrical, conical or flat surface which must be brought to a fairly smooth surface. The work is either mounted between centres or clamped to the face plate as usual. The grinding wheel is mounted on a spindle which is carried in a head fastened to the carriage of the lathe. The spindle is usually driven by means of a motor located on a bracket which is firmly fastened to the carriage. The bracket is situated a sufficient height above the carriage that the belt will operate satisfactorily. —Grits and Grinds.

ALUMINUM FUSE MAKING TROUBLES

ALL the difficulties in connection with the Russian shrapnel and high-explosive orders placed in the United States are not yet over, says a New York press despatch. Of total orders for 13,000,000 of these shells (excluding the Canadian Car & Foundry 5,000,000 shell order), probably not more than 3,000,000 have been shipped. Deliveries, however, are gaining in volume, and, while it is hardly likely that the orders will be completed within the contract limits, or by April 30, it is not unlikely that the end will then be in sight.

One of the principal causes of delay has been the employment of aluminum for the fuses, or for some of them. Aluminum, it appears, is subject to quicker fragmentation than brass, and for this reason the greatest trouble has been experienced in getting fuses made of the metal to function.

Under the adjustments made early last October, some of the aluminum fuses were changed to brass, and concerns which had been more successful in the fuse end of the business took over in some cases, parts of the fuse orders of others. From that time shipments, till then practically nil, have improved, but the delivery figure given above shows that there is still room for improvement.

	Shrapnel	High-Explosives
Bethlehem Steel	2,500,000	2,500,000
Eddystone Munitions	2,500,000	
American Can	2,500,000	
General Electric	750,000	1,000,000
International Shell and Ordnance		1,000,000
Bartlett-Hayward	750,000	

High Pressure Steam Stop Valve Design and Construction

By D. McNicoll

In what follows, investigation is made of various designs of steam stop valves, particular attention being given those accessory details which contribute to the general efficiency and operation safety of each individual unit, whether for service ashore or on board ship.

IN designing high-pressure steam stop valves, the essentials to be observed are tightness, reliability, simplicity, and safety. In small sizes not exceeding 4 in. or thereabouts and of single-beat type, these essentials are obtained without much call for special consideration, but as the sizes increase the design demands careful attention. In the succeeding columns an investigation of the various designs is contributed, and prominence given to details which affect what might be termed the general efficiency and safety of the fitting.

Fig. 1 shows a type of single-beat unbalanced stop valve frequently used as a boiler stop. The same design in more or less modified form is used throughout most main steam-pipe systems, being met with as an intermediate shut-off or bulkhead stop valve. The valve shown is of 8 in. diameter, the material of chest being cast-iron, internal parts gunmetal, and the working pressure 200 lbs. per square inch. In many instances chests of this size and for this pressure are made in cast steel, but provided the design is carefully observed the choice of material is optional. For larger sizes or higher pressures cast steel is desirable. Independent of pressure, wherever superheat is present, cast steel is essential, and the internal fittings in this instance should be of a high-tension bronze, preferably a nickel alloy.

The features in the design which call for special attention are stresses in the chest due to pressure; stresses due to hardening down; stresses due to expansion of spindle with valve shut; tendency of valve to rotate when steam is flowing through; liability to fracture of seat studs. In settling the thickness of body metal, the general method is to ensure that the aggregate section is such as to allow of a safe stress per square inch of section, but on investigation it is readily admitted that all parts are not equally stressed.

In Fig. 1, assuming that the pressure is present throughout the chest and acting at right angles to the plane of section shown, the stress on the part lettered A is much higher than on the other portions. By way of illustration:—The pressure on the upper half of the outlet and half the cover is approximately 8,950 lbs.; which stresses the section on the top left-hand side to 1,061 lbs., per square inch, whereas the average stress for the aggregate section is only 891 lbs. The cover, of course, takes a portion of the stress due to frictional resistance, and the tighter the cover nuts are screwed up, the greater the assistance

given to the weaker section. In a sense this is "robbing Peter to pay Paul," as it simply puts up the stress on the studs.

The stresses resulting from excessive hardening down are in many instances exceptionally high, as is often proved by the burst condition of valve lids. This hardening down is due to an attempt to overcome leakage. It appears providential that the valve lid gives way in nearly every case, or otherwise there might be far more fatal accidents in this connection. Steel crossheads and turned pillars should always be fitted in preference to cast bridges, the latter being anything but safe, particularly in the larger sizes. There is no doubt that in valves over 4 in. diameter a great benefit accrues from the adoption of a flexible seating in conjunction with the solid face. This was introduced by R. R. Bevis, J. H. Gibson and Coekburns, Ltd. With this arrangement leakage from distortion is obviated, and, in addition,

cold, and afterwards steam from other boilers admitted to the top of the body. Even with steam in the inlet side only a fair degree of heat is transmitted to the spindle. In each case the subsequent tendency to expansion puts a stress on all the parts. An actual experience of the author is illustrated in Fig. 2. This was a double-beat type of valve and the bottom seat was attached as shown. The valve was hardened down for a steam test, with the result that after the test a number of the manganese bronze studs from the bottom seat were found lying broken in the bottom of the chest, and all showed signs of fracture, the expansion of the spindle having caused this.

Apart from this, the design of seat is not to be recommended even if the studs do not give way, as the tendency thereby is to cause a leaky joint between chest and seat. Seats should be arranged where valves have to be hardened down so that this hardening tends

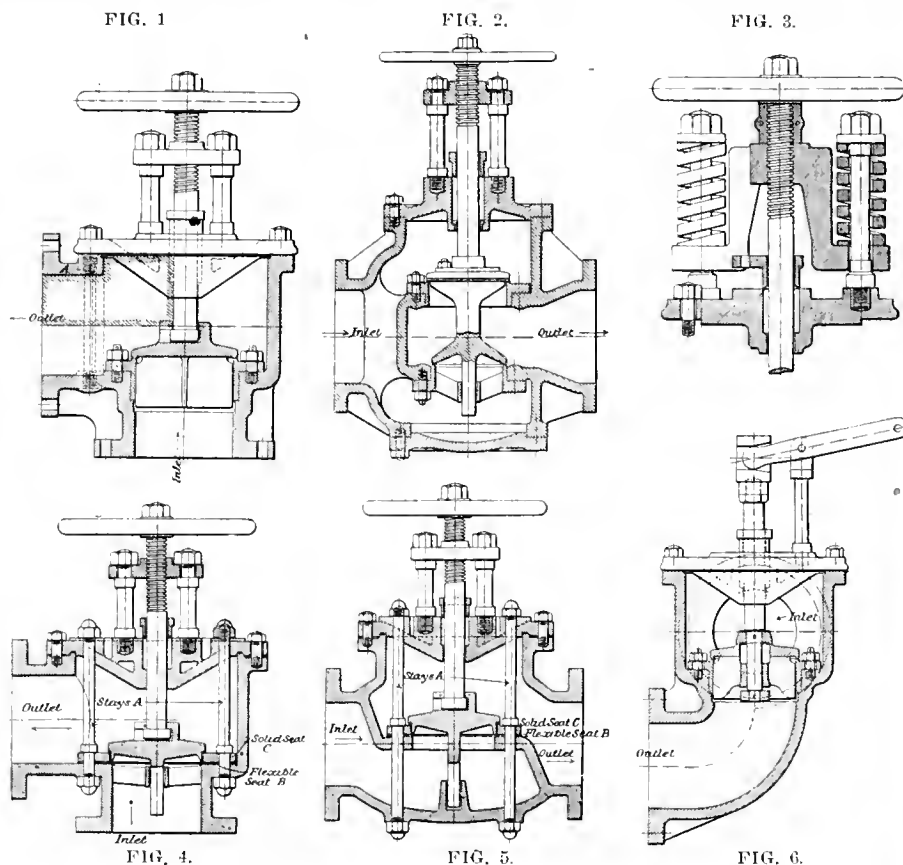

there are two faces, so that if one is leaking from any cause of distortion there is always the other one to fall back upon.

Shutting Down Hard When Cold

Another source of high stress is when the valve has been shut down hard when

to make the joint tighter, that is to say the gunmetal seat should be upon the top of the steel seat, and not below it as shown. One method of counteracting the damage from expansion is by fitting a spring crosshead. This is shown in Fig. 3, and is loaded generally from 1 1/4

From a paper read before the Institute of Marine Engineers.

to 1½ times the boiler pressure per square inch of valve area, and a higher load than this cannot be put upon the valve spindle, no matter what purchase is used. In Fig. 1 stays are sometimes fitted as shown dotted. These only serve to stiffen the cover and, as will be noticed, still further reduce the section of metal at an already weak section.

The rotation of winged valves when steam is flowing is due either to a slight angle on the wings or to eddies in the steam. The valve can be prevented from rotating but to do this a pin must be fitted or other means adopted. The damage done to valves from this rotation is hardly credible, and calls for the adoption generally of pintle or centre-guided valves.

Valve Seat Fixing

The source of much trouble is the fracture of seat-securing pins or studs. In the large sizes it is quite inadmissible to drive the seats in and secure them by means of a pin or pins through the side of the chest and it is absolutely prohibited in all sizes when superheated steam is present, experience showing in this case that seats driven and secured by side pins become quite slack and allow leakage to occur. The seats in larger sizes are therefore secured in the manner shown in Fig. 1. The only way to avoid serious trouble with this design is to run a wire through the heads of all pins or through split pin holes, if studs are fitted. This prevents the fractured portions being carried to some part where serious damage may be caused.

The question of draining generally cannot receive too much attention, and means should always be provided for

ing pressure which acts at right angles to the axis of the spindle. This consists of a tapered spigot on the chest with a corresponding tapered recess in the cover, making a metal to metal joint. The stresses from hardening down and ex-

fitted or handwheel spanners used to give the same effect or gearing introduced. The difficulty is due to frictional resistance in the screw and not to the direct load which, but for that resistance, would allow for quite a reasonably

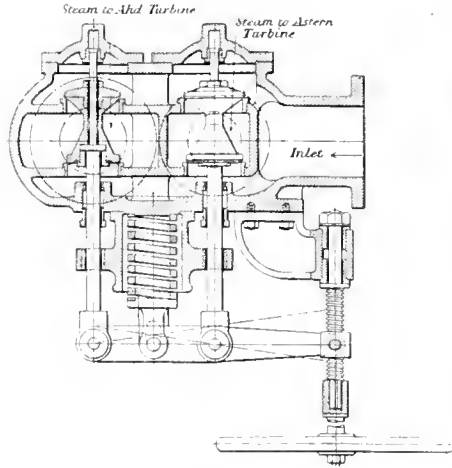

FIG. 8.

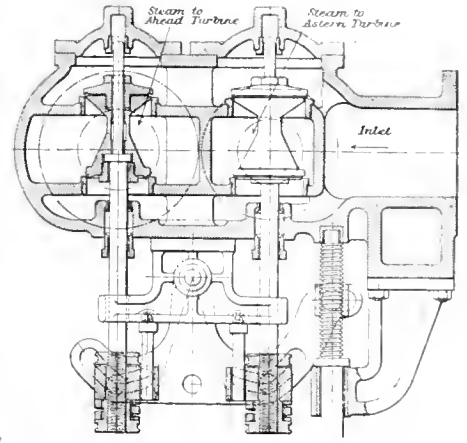

FIG. 9.

pansion are mainly taken up by the four stays A, which also serve to secure the seatings. With this arrangement no loose parts are situated inside the chest, with the consequent prevention of damage from this source. The valve is centrally guided thus preventing rotation. A flexible seating is shown at B and when this and the corresponding valve face engage, the solid seat C and its corresponding valve face are 1-100 in. open, so that when this latter seat and face engage the flexible seating is deflected 1-100 in. Fig. 5 shows the same design of valve as in Fig. 4.

sized handwheel and comparatively quick-pitched thread in valves up to about 12 in. diameter. For regulating purposes large diameter handwheels or gearing are objectionable, not enabling the valve to be handled as expeditiously as is desirable. A compromise for this type of valve is effected and is shown in Fig. 6. A pilot valve is introduced and lifts first, balancing to a certain point the pressure in inlet and outlet branches. The main valve is then lifted against much less load. This fitting is extensively adopted, but occasionally trouble is experienced from the main valve pulsating or clattering, in reciprocating machinery, due to the fluctuating flow of steam—which causes damage to the internal parts.

Solid double-beat valves got over this trouble in the majority of cases and were perfectly balanced to all practical purposes, but they had one outstanding defect—they were rarely, if ever, steam-tight, which was very unsatisfactory. For reciprocating work this did not affect the steam consumption to any extent, as it was only when the machinery was at a standstill that leakage was occurring, and if a stoppage was of any length of time the boiler stop valves could be shut down. For turbine machinery, however, leaky astern valves can very seriously affect the economy. The leakage in the solid double-beat stop valve was due to differences of expansion between the double-beat valve and the seatings in the chest and could not be got over. A solution of the difficulty was ultimately found in introducing a flexible disc to one of the beats, and the names associated with this introduction were also Messrs. Revis, Gibson, and Cockburns, Limited. This valve has been very extensively adopted in varying designs and is exclusively used for all regulating valves in His Majesty's Navy.

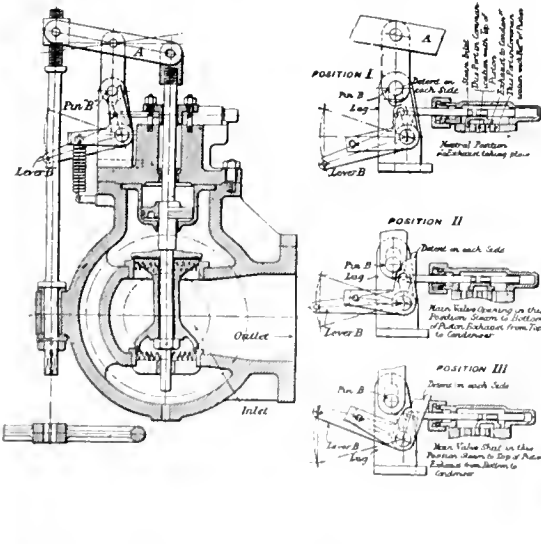

FIG. 7.

FIGS. 7a, 7b, 7c.

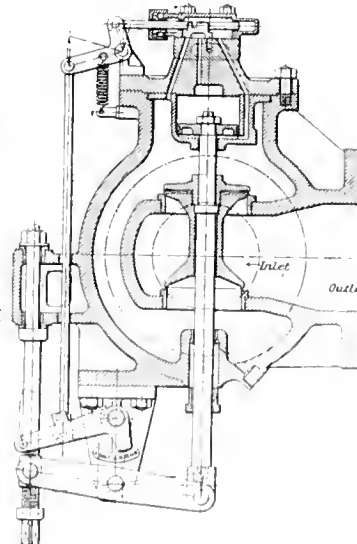

FIG. 7d.

efficiently getting rid of all water in both inlet and outlet before a valve is opened.

In Fig. 4 a type of valve is shown which it is suggested is an improvement on that shown in Fig. 1. The first feature that attention is desired to be drawn to is the method employed so that the cover may take up a share of the burst-

but of straight through or globe type; the design calls for the same attention as in the previous case.

Balanced Valves

In singlebeat valves of sizes over 4 in. and pressures in the region of 180 lb. and above, the valves are difficult to operate unless large diameter handwheels are

Double Beat Valve for Reciprocating Work

Fig. 7 shows a double-beat type of valve used for reciprocating work for regulating purposes and also as a throttle valve, doing away with the butterfly type. In this latter capacity a very light duty is thrown on any form of governing gear, while in larger sizes it obviates the necessity for employing a separate throttle engine, say of the Brown type. For ordinary opening and closing as a regulating valve the pin B is locked by the detents as shown, thus allowing the valve to be positively opened or closed. During these operations the control valve is in the neutral position, preventing steam from passing to the condenser. The operating piston has also inlet pressure on both sides of it, thus effecting a balance. The two beats of the valve have saw-formation spigots: this is to allow of close regulation, particularly where shafting is employed to bring the handwheel to a position not directly below the valve. The back-lash in this instance often allows a big jump to occur in the regulation, which is prevented with the design as shown. This jump is due to the following cause:—

With a valve of this design, that is, with steam entering outside the beats and the spindle going through the cover, there is in the first instance a closing effort due to the pressure on the increase in area of the top beat. The pressure on the area of the spindle where it passes through the stuffing-box is an opening effort. Generally the ratio of the former area to the latter is as two to one, with the result that when the valve is opened to an extent allowing half the initial pressure to be present in the outlet the efforts balance each other. A pound or two over this and an opening effort is present, with the result that the valve jumps open whatever play there is in the operating gear. With the saw formation of spigots this jump does not affect the revolutions to any extent. If instead of the spindle coming through the top of the cover it had come through the bottom of the chest the effort would have been a constant closing one, and there would be no necessity for the provision of the saw formation of spigot. Further on, valves with their spindles coming through the bottom of the chest are shown in Fig. 7d, 8, 9 and 10. The saw formation of spigots is a refinement to give close regulation from dead slow to full speed, as many doublebeat valves are made without this formation. When the valve is opened to any degree of regulation it can be shut and opened again by the throttle gear in the following manner: In Fig. 7a, b, c the throttle lever B is moved from position 7a to 7c. The control valve during this operation moves through position 7b, holding the main valve open till the detents have cleared themselves from the pin B, then with the throttle lever in position 7c the main valve closes—the levers swinging from the nut on the

regulating screw. To open up again the lever B is returned to position 7a, the main valve opens up and the small tension spring returns the detent, again locking pin B and putting the valve into a position of positive control. This fit-

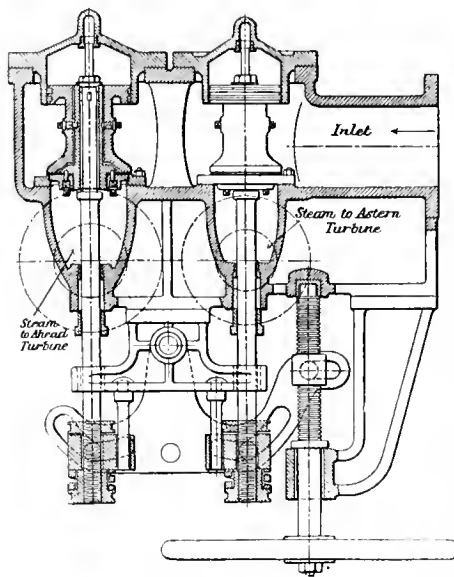

FIG. 10.

ting has given general satisfaction and has been extensively adopted.

In future it is intended to make the last type of valve as modified and shown in Fig. 7d. A constant closing effort is present, which will allow of perfect regulation under all circumstances and will not necessitate the adoption of saw-formation spigots on the beats. The action under throttling conditions is similar to the former valve, with the difference that the slide valve is returned from position 7c to position 7b and 7a by the spring, assisted by the inlet pressure on the area of the slide-valve spindle where it passes through its stuffing-box.

Hardening-down stresses are alleviated by the expansion of the spindle under temperature. The illustration also shows the relative positions of ports and passages, and consequently gives a better idea of the connection between

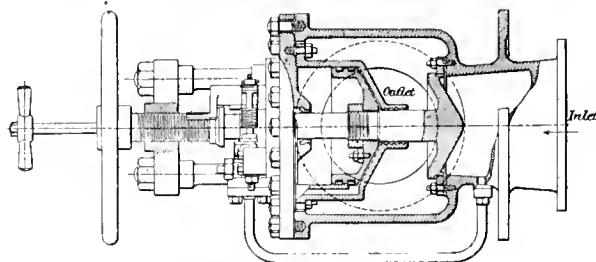

FIG. 11.

the positions of the controlling slide valve and the positions of the main valve than is shown in Fig. 7.

To prevent water coming down between the spindle and stuffing-box of the main valve, as far as possible, the stuffing-box is kept high in the inside of the chest, and a drain-hole provided at the top of the

packing to drain any water that may tend to accumulate there to the bottom of the chest. Provision is also made for taking away any drips that may come down.

In both the foregoing valves the design has been devised from the point of view that the relative positions of the indexes for both main and throttle valves at the starting platform are exactly similar to those where separate valves are fitted. A point of particular importance has also been carefully observed in the design, namely, that wear and tear have no effect on the efficiency of the gear.

Regulating Valve for Turbines

Fig. 8, page 10, shows a type of ahead and astern doublebeat regulating valve for turbine machinery, of which a large number have been fitted. With this arrangement one handwheel only is necessary. In a mid position both valves are shut, rotation in one or other direction opens either valve, the shut valve meanwhile becoming the medium of the fulcrum for the opening valve. In a design of this sort it is essential that the handwheel should be most clearly marked by arrows for rotation for ahead and astern. Not only should the handwheel be marked, but an index should be fitted with a pointer of considerable travel indicating quickly which valve is being operated and in what direction. This also applies to single regulating valves because, while in the majority of cases valves are shut by what is termed a clockwise motion, that is right-hand when looking on the handwheel, with the valve or extending spindle receding from the same, there are cases of extended spindles where the motion is clockwise looking in the opposite direction.

With the arrangement as shown in Fig. 8 it is possible, if the spindle of the open valve seizes in the neck bush or gland and it is desired to shut this valve and open the other one, that instead of shutting the open valve first the other valve is opened up—a most undesirable effect. To obviate this the design as shown in Fig. 9, has been

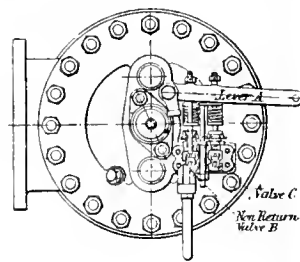

FIG. 11a.

adopted, with most satisfactory results. Here the open valve must be positively shut to the point of the spigots entering the seats before the opposite valve can be opened. After this point the valve is closed and contact made with its seat by the pressure of steam on the difference of area of the two beats of the valve, plus the pressure into the area

of the valve spindle where it passes through the stuffing-box. The springs on the spindles also assist this effort. No greater closing effort can be put upon the valve. In this respect it differs from the fitting shown in Fig. 7, where, of course, the valve can be hardened on its seat to any extent.

Another arrangement of balanced valves which has a much greater final closing effort, and consequently ensures tighter valves, is shown in Fig. 10. The valves are balanced by the control valve, which forms part of the spindle, first exhausting steam from the top of the piston. Another outstanding feature is the simplicity of the chest casting, particularly desirable in cast steel. The closing effort when the valves are shut is the pressure on the area of the valves. In these designs of double manoeuvring valves and valve as shown in Fig. 7b it will be noticed there are no stresses due to expansion of spindles.

Valve for Turbine Service

A valve widely adopted in conjunction with turbine machinery for both naval and mercantile work is shown in Figs. 11 and 11a. This fitting is a combined bulkhead shut-off and emergency valve. It also fulfills the function of a self-closing valve in naval work. For ordinary opening and closing the valve is operated in the usual way by means of a handwheel. In the larger sizes it is necessary to employ a handwheel spanner. When the main valve commences to open the collar on it has an inclined plane action on the lever A which lifts the spindle of the non-return valve B, allowing steam to pass to the top of the piston and check any sudden opening tendency. The leakage past the piston rings determines the opening speed of the valve. For shutting by throttle or emergency gear, the lever A is moved further, which opens valve C; this exhausts steam from the under side of the piston, when the pressure on top of it closes the main valve. On returning the lever the main valve slowly opens up to its previous amount of lift. For naval work, where there are two or more bulkhead valves, if the pipe on the inlet side of one valve is shot away the valve is supposed to self-close with the reverse flow of steam. When this occurs the non-return valve B also closes. The efficiency of this fitting was lately demonstrated unintentionally in a fast ship of war. An exceptionally heavy sea broke over the vessel, the turbines stopped, and for some time no explanation was forthcoming; ultimately it was found that the sea had carried some gear against the deck emergency lever and moved it into the shut position, with the result that both bulkhead emergency valves were effectively shut.



CUNARD SHIPS IN U.S. YARDS

THE placing of contracts for merchant vessels by the Cunard Steamship Line has been noted from time to time within the past few weeks. An official

statement has now been issued by James McNaught, of Esplen Sons & McNaught Inc., naval architects, who have acted for the Cunard Co., in placing orders for boats with American shipyards: "Details of the Cunard shipbuilding cannot be given, as the company is under the British censor, but I can say that the Cunard construction program is the greatest in the history of shipbuilding. Orders are being placed in almost every available yard. The Bethlehem Steel Co. is to build ships at the Maryland and Fore River yards and at the Union Iron Works. The Todd Shipyards Corporation has orders for six ships of 7,500 tons at the Seattle yard. The Sun Shipbuilding Co. also has orders."

"Ships to be built in the United States vary from 7,500 tons to 12,500 tons. Several steamers are being built for the Cunard Co. in England, and at least one will have turbo-electric propulsion. At present England has three or four ships under construction of that class. Trials of this power have been sufficient to justify installing this machinery on one of the big Cunarders. I cannot give the size of these vessels. One of the small steamers with the new power will be of 5,500 tons. They will all be capable of high speed. We have found that the electric installation can be so constructed as not to reduce the carrying capacity, and need not add to the work of the vessel."



EMPIRE ZINC OUTPUT

THE annual meeting of the Amalgamated Zinc Co., as reported in the London *Statist*, shows what changes the war has forced. The properties are in Australia. Before the war the company was producing zinc concentrates at the rate of about 150,000 tons per month, the zinc contents averaging 49 per cent., or, say, 75,000 tons of pure metal. These concentrates were shipped to Germany, where they were treated for the production of commercially useable zinc. The Amalgamated Co. has just about installed its first unit of plant for electrolytic zinc production, which has a capacity of between ten to twelve tons of electrolytic zinc per day, or, say, 3,000 to 3,500 tons per month, which will require about 4,000 horse-power. In order to warrant the establishment of this plant, New Zealand made a contract for the disposal of the product of the new company for ten years to the Imperial authorities under a guaranteed price.

The Consolidated Mining & Smelting Co. of Canada has been going through the same process, having made a contract for its output with both Great Britain and Russia. It is understood that the Consolidated Co. is now turning out some 35 tons of commercial zinc per day, which is being gradually increased. The company, through its ownership of the West Kootenay Power & Light Co., controls some 40,000 horse-power, which is available for this and similar purposes.

INDIA BUYING STEEL IN U. S.

MITSUI & CO. will send two steamships from Seattle to India this spring, each loaded to capacity. The Amogisan Maru will sail this month direct from Bombay with approximately 3,000,000 feet of lumber, and the Niels Nielsen will sail in May with 8,800 tons of steel and lumber for Calcutta and Bombay, says the *Seattle Times*.

Traffic between Great Britain and India via the Suez Canal has ceased because of war conditions, and India is now looking to the United States for steel and tin products as well as lumber. News of the decision of Mitsui & Co. to send the two vessels to India this spring was obtained from the corporation's Seattle headquarters.

In the last few weeks a number of inquiries have been received in Seattle as to the possibility of getting space in vessels for India. The inquiries relate chiefly to steel, tin plates, structural products and lumber. These shipments are needed in India for ordinary construction work. Before the closing of the Suez Canal to traffic, India obtained its steel and similar products from England.



CANADIAN GOVERNMENT RAILWAYS

STATISTICAL information regarding the Canadian Government railway is contained in the annual report of the Railway Department, issued at Ottawa, on March 8. The total expenditure, including the Quebec Bridge, amounted to \$43,627,328, of which \$23,902,068 was charged to capital, \$19,408,780 to revenue, and \$1,716,051 to income. The outlay on the Transcontinental was \$11,488,980 on the Intercolonial \$21,702,441, and on the Prince Edward Island line \$1,350,472.

Revenue derived from Government railway and canal works aggregated \$18,874,630, of which over eighteen millions came from the railways. Before and since Confederation, Canada has spent \$118,614,725, on its canals and \$377,146,699 on its railways. This includes the Quebec Bridge and subsidy to the C.P.R. main line.

The Intercolonial had a good year. Its earnings were \$14,068,791, and working expenses \$12,551,495, producing a surplus of over one and a half million dollars. On the Prince Edward Island Railway there was a deficit of \$154,093, and on the International Railway—a leased line in New Brunswick—\$12,027, exclusive of \$90,000 paid on interest.

The mileage of Government roads is 1,527 an increase of 78 in the year. The number of passengers carried was 412,535 a decrease of 10,961.



Black Color on Brass.—A black color on brass can be obtained by the use of the following solution: White arsenic, 2 ozs.; potassium cyanide, 5 ozs.; and water, 1 gallon. This is used as a hot dip without current. The work is immersed in the mixture, either suspended by wires, or in a basket, the solution being contained in an enameled tank or container.

EDITORIAL CORRESPONDENCE

Embracing the Further Discussion of Previously Published Articles, Inquiries for General Information, Observations and Suggestions—Your Co-operation is Invited

MACHINISTS' INSTRUCTION COURSE—XV.

By J. Davies.

SCREW threads are produced commercially in a variety of ways, involving different types of machines, either specially designed or else suited for using accessory devices, such as taps, die-heads, etc. Occasions still arise where the use of a screw-cutting lathe is the only means of performing the work; the following remarks applying more particularly to the actual handling of the lathe, change gear calculations—having been dealt with in previous articles.

Cutting a Vee Thread

When a screw-thread is to be cut, the tool is ground and shaped to suit the

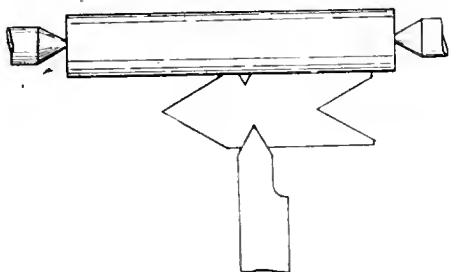

FIG. 53.

finished thread, the side faces forming an angle of 60 deg. This angle is tested by using a thread gauge, shown in Fig. 53. The gauge should be held so that the back edge of it lies flat against the work while the point of the tool is adjusted to fit the notch in the front of the gauge. It is sometimes convenient to hold the gauge as shown in Fig. 54; when one edge of the tool is properly set, the other edge will be at the correct angle, providing the tool is properly ground.

In cutting a vee thread the tool rest should be moved around 30 deg. for American threads and 27½ deg. for Whitworth threads, this being half the angle of the thread. The reason for this is that when a cut is taken, the tool cuts on one side only, which gives a cleaner and better thread than is the case when the tool-rest is set at right angles to the lathe centres. In the latter case the tool must cut on both sides at once, which means a smaller cut and a rougher finish. (See Fig. 55.)

Before commencing the cut, care should be taken that the tool is securely fastened in the tool-post, and that the lathe-dog is firmly secured to the work. Select a lathe-dog that fits the work as closely as possible. File or chip a flat spot on the work for the point of the set-screw, unless the nature of the work prevents this being done. The feed should run from right to left for cutting a right-hand thread and from left to right for a left-hand thread. In putting

on the cut, it will be found very convenient to run the tool rest up against a stop, Fig. 56, at every cut. By this means we return the tool exactly to the position it was in when we started the previous cut, and then by simply turning the stop screw back an amount equal to the cut required, there is not the same necessity for observing the graduations marked on the cross-feed screw, or the more cumbersome method of chalking. This stop is not usually fitted to the lathe by the makers, but it is a very simple matter for any mechanic to fit one up for himself.

Engaging the Nut

In cutting a short thread, the tool is often carried back to its starting place by means of a cross belt which reverses the lathe. In a very long job this is a serious waste of valuable time. The quickest method of taking the saddle back is by hand, but in doing so we must locate the exact time and place for putting in the nut for the next cut.

(1) When the number of threads on the work can be divided by the number of threads on the leading screw without a remainder, the nut may be engaged at any time or place.

(2) When the leading screw makes two or three or any number of complete revolutions to one revolution of the job, put a mark on the job or face plate; then every time that mark comes to a given place the nut can be engaged, or in a slow-running job put a mark on top of the face plate and another on top of the leading screw; then when both marks are on the top together you may put in the nut to start another cut, providing the carriage is touching the tail-stock or some other definite starting place.

In all other cases put down the pitch in fractional form reduced to its lowest term. The numerator will indicate the least number of complete inches that the carriage must travel, after taking the nut out of gear with the leading screw, before it comes to the right place to put it in again.

Starting the Cut

Put the carriage against the tailstock

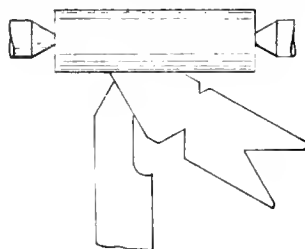

FIG. 54.

for a starting place, and measure on the lathe bed the required number of inches, or some multiple of the same, according

to the length of screw to be cut. Stop the lathe at this mark, and run the carriage back to the starting place for a fresh cut. After taking the first cut, measure the thread carefully to see if the lathe is cutting the right pitch. In thread cutting it is important that the tool should be set exactly at the centre. If the tool is set too high or too low, it will make an imperfect thread. When the tool commences to cut it is sprung to one side a little until it is advanced up the thread far enough to cut on both sides; this causes a thick thread on the end, which is apt to deceive one when fitting it into place. To avoid this, leave the portion to be threaded a little longer

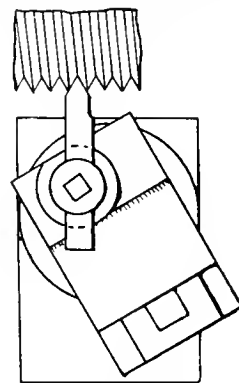

FIG. 55.

than the length of the thread and cut off the thick end the required length after the screw is finished.

Cutting Multiple Threads

Select the wheels so as to have one on the lathe spindle that can be divided into two or three equal parts as required, and proceed the same as for single threads until one thread is cut, with the exception of the finishing cut. Chalk the bottom of any one space on the spindle gear, and also chalk the tooth of the change gear which meshes with this space. If it is a double thread, count half the number of teeth on the change gear and mark in the same way. Adjust the quadrant or swing plate so that the second marked tooth will mesh in the chalked space on the spindle gear, and proceed to cut the second thread. When taking a finishing cut, take the screw out of the centres, so as to be able to move the saddle back without moving the tool, drop the quadrant and mesh the gears at the next chalk mark and finish the second thread. The same method will do for three or more threads. This is the generally accepted way for cutting double or triple threads, although there are other ways which, under favorable circumstances, are quicker and more convenient. For instance, a double or triple thread can be cut at one operation by a tool that is filed up with two or more cutting edges to suit the

required pitch, or on some jobs, such as cutting a one-inch pitch with a half-inch lead-screw, a cut can be taken from each thread alternately without changing the

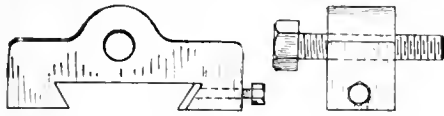

FIG. 5b.

gears by engaging the nut when the work has made half a revolution.

Left-hand Threads

In cutting a left-hand thread, the direction of the travel of the tool is generally reversed, either by reversing the quadrant or putting an extra wheel in the train of gears. This method is not always the best, as, for instance, the cutting of a left-hand thread inside a long sleeve can be done by reversing the lathe and commencing the cut at the same end, as a right-hand thread would be started ordinarily. The advantage of this is that the lathe hand can see ex-

actly straight and level and the machine is also level and properly squared up with the shaft. The machine pulley is 15 in. dia. and the line shaft pulley is 6 in. dia., with 6 ft. centres. When the belt is crossed one way it runs over on the tight pulley and will not stay on loose pulley without belt shifters and when crossed the other way it runs over on loose and will not stay in tight pulley. I would appreciate an explanation so that I may cure the trouble if possible.

Answer.—The trouble is due to one of the following conditions being near the limit, with regard to the others:—The centres are too close, or the belt is too wide, or the difference in diameter of the pulleys is too great. The accompanying diagram shows how these points affect the behaviour of the belt as described. The arrows indicate direction of movement, A being tight side of belt, and B the slack side. Sketch (a) shows the shape of A before B is in position. It will be noted that the widest part (x) is at a point midway between where the belt leaves the pulleys. When the

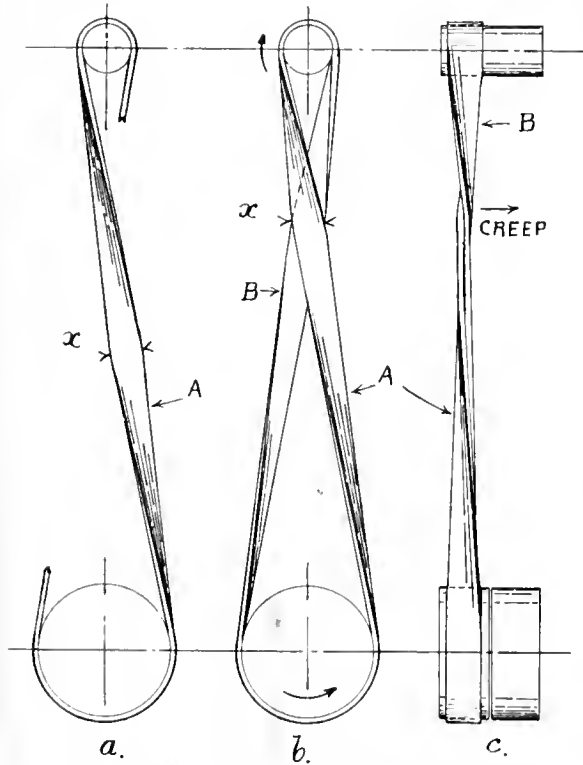

BELT TROUBLE DIAGRAMS.

actly what the tool is doing before it has time to do any damage, as would happen if the nut were engaged with the shaft at the wrong place, a thing which the best of lathe hands will do sometimes. The disadvantage is that the cut has a tendency to unscrew the chuck off the lathe spindle. When a left-hand thread is to be cut in this way, the chuck should be put on with a slight bang to insure that it will not easily unscrew itself.

BELT TROUBLE

Question.—I am having trouble with a belt drive which I would like you to advise me about. The line shaft is per-

fectly straight and level and the machine is also level and properly squared up with the shaft. The machine pulley is 15 in. dia. and the line shaft pulley is 6 in. dia., with 6 ft. centres. When the belt is crossed one way it runs over on the tight pulley and will not stay on loose pulley without belt shifters and when crossed the other way it runs over on loose and will not stay in tight pulley. I would appreciate an explanation so that I may cure the trouble if possible.

Foundry Tumbling Barrel

SOME time ago, having a very large quantity of small castings to supply, says a writer in the *Foundry Trade Journal*, we decided to build a small rattler or tumbling barrel, as the large

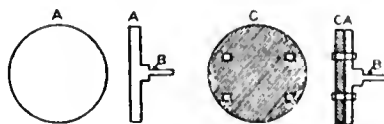

FIG. 1.

FIG. 2.

iron ones caused a great deal of breakage. The measurements of the new one were 15 ins. inside and 3 ft. long, this holding a barrow-full at a time. The

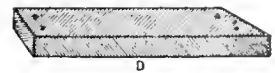
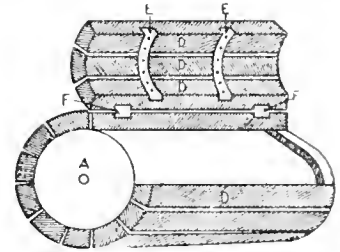

FIG. 3.

method was as follows: Cast two discs 15 ins. dia. and 1 in. thick, with a spindle as shown at B, Fig. 1. Make two wood discs and bolt on to face at CA.



FIGS. 4 AND 5.

Fig. 2. This method saves drilling and machining, for the wooden bars, D, Fig. 3, can be screwed on to the disc. The lid, Fig. 4, is of three bars screwed on to sections of wrought iron bent to cor-



FIG. 6. FIG. 7.

rect angle at E and D, Figs. 4 and 6, and mounted as shown in Fig. 5 by hinges E. Next cast two blocks for bearings, and drill through as shown at G.

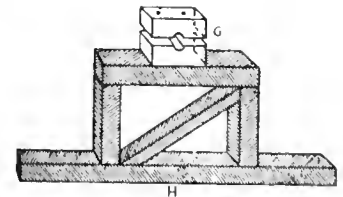

FIG. 8.

Fig. 7. The standards, H, Fig. 8, are of timber, 3 ft. by 4 ft.; these can be bolted to the floor.

The whole thing was put together by

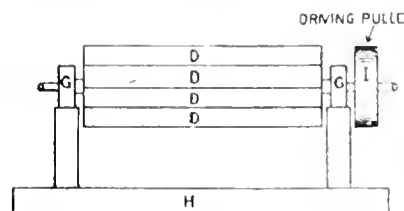
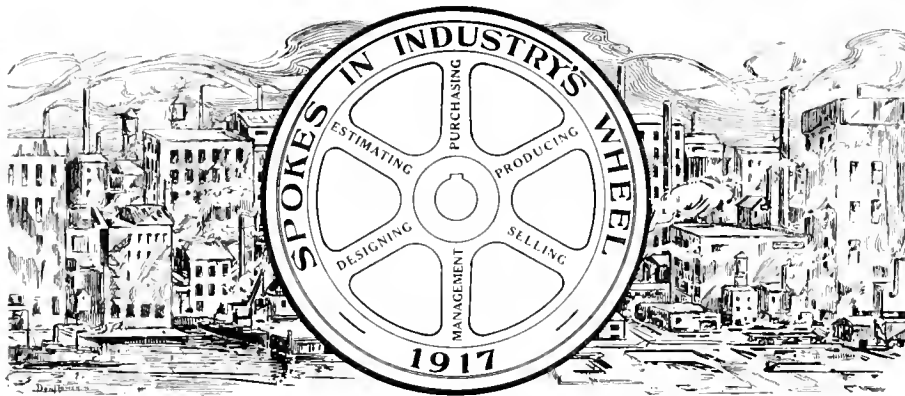

FIG. 9.

a carpenter, and cost about \$15. It can be attended by any lad, and proves a most serviceable and cheap tool for very light and small castings.



The constitution of industrial enterprise is largely departmental—"spokes in a wheel." This series of articles has for its object the featuring in a racy, interesting and instructive fashion, the training, experience and achievement of those who to-day are transmitting, effectively, energy in their capacity as "spokes in the wheels" of our metal-working establishments.

WILLIAM MARTIN McROBERT

AT a time like the present, when surmises regarding future conditions are being made on all sides, and the probability of intensified competition looms up as a result of Britain's industrial awakening, it is reassuring, to those solicitous of Canada's future, to know that a prominent feature of the rising generation of engineers is the large number who, by birth, ancestry, or educational experience, have been able to absorb to a large degree those characteristics of the British race which, in view of future possibilities, may afford apt illustration of "diamond cut diamond."

A prominent English engineer, with world-wide experience, once remarked that Scotland was all right for breeding men, but was no use for feeding them. There may or may not be any truth in the latter part of the statement, but many of our readers who are acquainted with William Martin McRobert, sales engineer of the Galt Foundry Co., Galt, Ont., will be in perfect agreement that a deal of truth is contained in the first part of the remark.

Mr. McRobert is a native born Canadian, having first gazed upon the maple leaf in the immediate environs of London, Ont., in the year 1876. When three years of age his parents returned to their native land and settled in Aberdeen, where our "Spoke" spent his early years, his education being received at Aberdeen Grammar School and Gordon's College. That he had early absorbed a due share of that determination and tenacity which are so authentically attributed to residents of the "Granite City" was evidenced by his decision to go through the mill as an apprentice engineer.

Much has been written and said regarding the value of experience in the eyes of Scotch people, and a recital of apprenticeship conditions under which our friend gained his knowledge of wheels and things may account in some measure for this trait. Commencing early in his teens, he started work at 6 a.m., quitting at 5.30 p.m., with two

stops for breakfast and dinner. The remuneration offered seems to have been in inverse ratio to the hours worked when judged by Canadian standards. For instance, we are informed that the young apprentice was rewarded with the sum of 75c per week the first year, with annual increments of 25c per week up to the sixth year. Technical education was obtained through evening studies at the local Technical School over a period of four years.

These conditions easily made it a case of the survival of the fittest, a further



WILLIAM MARTIN McROBERT.

test of tenacity being the necessity of making up all lost time as double hours before the youthful journeyman received the coveted "lines," i.e., certificate of apprenticeship. Some certificate!

Dalgety Brothers, Aberdeen, was the firm where this training was undergone, and a short time afterwards our friend entered the service of the "P. and O."

line of steamships, climbing through the various grades to the rank of senior engineer, for which it was necessary to pass the Board of Trade examination for first-class engineer. A decade spent on ocean mail steamers familiarized Mr. McRobert with the operation and upkeep of power plant equipment to a degree seldom obtainable in land installations. The necessity for avoiding breakdowns at all costs, and the limited facilities for effecting repairs in case of accident developed an alertness and self-reliance which is typical of the modern marine man. It is not surprising, therefore, that when, after ten years of sea life, our "Spoke" decided to settle in the land of his birth, he was appointed chief engineer of the Canada Foundry Co., Toronto, a position which he held for three years before transferring his services to Gunns, Ltd., Toronto, in a similar capacity, but with the additional duties of master mechanic.

As sales engineer for the Galt Foundry Co., Mr. McRobert finds ample opportunity for drawing on his wide experience, his energies being devoted to the development of the Galt sprinkler stoker and the McNaughton grate bar. No combination of circumstances is likely to offer very great difficulty in the application of his personally acquired knowledge of things mechanical. In the course of his travels Mr. McRobert has had frequent opportunity of studying industrial practice in nearly every civilized country, having, with the exception of Northern Europe and South America, visited every part of the globe. His travel record includes over 70 passages through the Suez Canal, and also coast to coast trips in Canada and United States.

Mr. McRobert's home life is centred in Toronto, where he resides at 92 Symington Avenue, his son being a student at Toronto Technical School preparatory to following a kindred career to that of his father. His experience in occasionally isolated situations gave Mr. McRobert more than ordinary opportunity for appreciating the value of technical study; in fact, he considers that for any engineer or mechanic having ambition to advance in his profession it is imperative that he should keep abreast of the times by combining with his practical knowledge the study of reliable engineering literature, also the reading of the many interesting and instructive articles appearing in the current issues of mechanical trade journals.

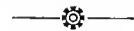

Questions.—What would be the pressure at the discharge end of a lubricating hose on a boring machine using gravity feed, the supply tank being located 30 feet above the floor?

Answer.—A column of water one foot in height and having a cross sectional area of one square inch will weigh .434 lbs. As the height of the discharge above the floor will be about 3 feet, the actual head of water will be 27 feet; therefore, the pressure at the machine will be approximately $.434 \times 27$ equals 11.7 lbs. per square inch.

PROGRESS IN NEW EQUIPMENT

A Record of New and Improved Machinery and Accessories for the Machine, Pattern, Boiler and Blacksmith Shops, Planing Mill, Foundry and Power Plant

PUMP VALVE RESEATING MACHINES

ONE of the chief factors in the maintenance of high efficiency pump operation is that of the care given the upkeep of the various valves forming part of each pump unit. The effect of wire drawing and the presence of grit in the water soon result in poor fitting valves; it is, therefore, essential that the accuracy of the latter and their seats be maintained. Where the failure of a pump to effectively perform its allotted task means the temporary shut-down of a portion of a plant, the question of prompt repairs is a very important feature.

The accompanying cuts illustrate several applications of the Dexter pump valve reseating machines, and feature their usefulness in the repairing of various types of pumps now in service.

Simplicity of construction of this apparatus is coupled with high efficiency of action; a feature of their operation being the ease with which they are attached to any valve chamber. For the smaller sizes of valves, the single yoke device is used, but for the facing of the larger valves a double yoke is provided. The latter offers additional support for the bearing sleeve, through which the tool spindle operates. This improvement is a highly desirable feature where the valve seats are somewhat below the surface in the valve chamber, as the double

parallel to the face of the cutter. In the large sizes, where more power is required, the cutter spindle is revolved by means of beveled gears working in a bracket secured to the upper end of the bearing sleeve; in this case the power handle operates at right angles to the cutter face.

Where the arrangement of the valves does not permit of using the long bearing sleeve, special devices are provided for the facing of the seats, the pressure being obtained by means of adjusting screws operating in the

seating tools meet the repair needs of valves on the high pressure hydraulic pumps installed in connection with shell forging plants.

Darling Bros., Montreal, manufacture



DEXTER PUMP VALVE OUTFIT DIE.

clamping facilities offer increased rigidity when the machine is in service. For the smaller sizes, the cutter is driven direct by a handle attached to the spindle, and is operated in a direction

quality steel, and are otherwise designed to meet their special work. The action of the cutter leaves the surface of the seat perfectly smooth and free from chatter marks. Other designs of Dexter re-

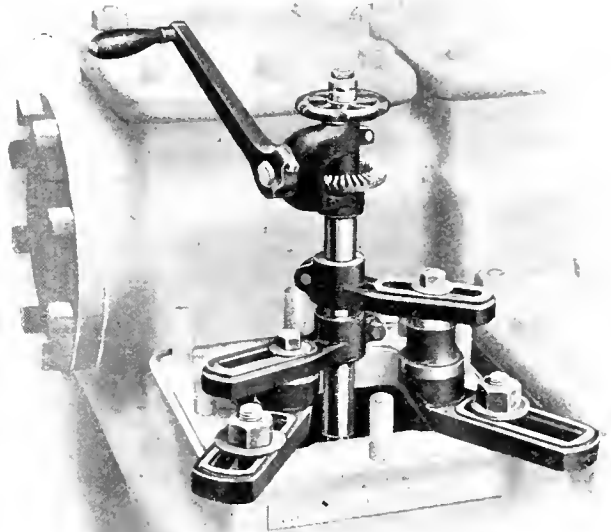

DEXTER DOUBLE YOKE PUMP VALVE RESEATING MACHINE REFACING SUCTION VALVE SEAT.

the foregoing products for Canadian distribution.

CONVEYOR TYPE AUTOMATIC HEATING FURNACE

THE accompanying illustration shows a unique type of gas or oil-fired furnace which has recently been built by Canadian Hoskins, Ltd., Walkerville, Ont., for the purpose of heating base plugs for



DEXTER PUMP VALVE ATTACHMENT RATCHET OUTFIT R

the press. The moving hearth is in the form of an endless chain, built up of four sections, side by side, the sections being advanced one-quarter of the pitch

deg. F., a rate of one plug every 2 sec. can be delivered at the exit end of the second chamber, which is maintained at the required temperature, irrespective of the speed at which the work passes.

ings being made of different metals according to work for which it is required. Quite recently a pump was installed in Toronto for handling asphalt, which shows the wide range of application of such a unit.

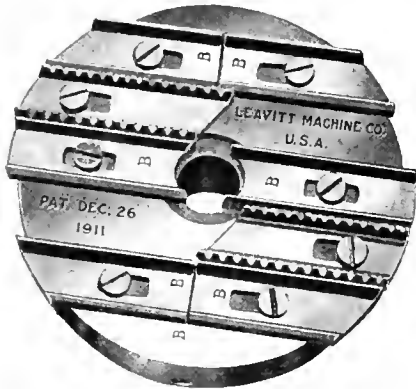

DEXTER IMPROVED TYPE PUMP VALVE CUTTER.

so as to stagger the joints evenly over the surface.

The chain links are protected by non-poreil cork brick, on which the work rests as it passes through the furnace.

At no time does the chain come in direct contact with the flame. Each link is in the furnace for only one-third of the time for each circuit, and does not attain a higher temperature than 900 deg. F., being cooled during the other two-thirds before entering again.

The furnace chamber is divided into two sections—the first one acting as a preheater, by varying the temperature of which the output can be increased or decreased to meet requirements. With

WATER SEALED ROTARY PUMP

THE Albany Pump Co., Toronto, are now building the Albany patent water-sealed rotary pump, which heretofore has been imported from London, England. The general design of this pump is similar to other rotary pumps on the market, in that it consists of a metal casing, inside of which revolve the impellers or wheels. The most important feature of this pump is the fact that slips and leakage have been reduced to a minimum by the introduction of grooves cut along the faces and edges of the teeth, so that in rotating a body of water lodges in the grooves forming an absolutely sealed water-tight joint or cushion between the casing and the rotating rollers, thereby producing an efficient v a c u u m. Centrifugal force also adds greatly to the efficiency of the pump.

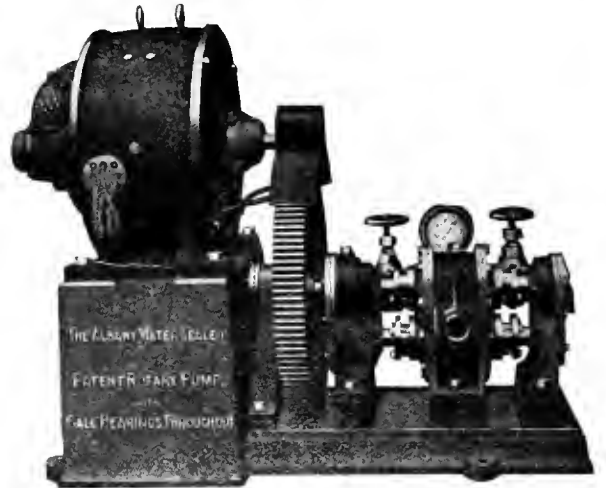

WATER-SEALED ROTARY PUMP.

The pump is suitable for dealing with all kinds of liquids, the wheels and cas-

the various outputs range from 700 to 60,000 gallons per hour. The speed of the smaller sizes, however, varies, the minimum capacity of the small pumps being 60 gallons per hour.

The "Albany" pump has achieved considerable success in pumping fuel oil, and several outfits have been placed in H.M. Dockyards, and are being largely used by the British and French Admiralties. After an exhaustive test, several of these pumps have been installed in H.M. submarines for pumping water from the trimming tanks.

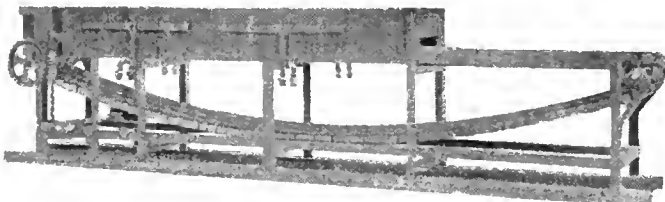

AUTOMATIC FURNACE WITH CONVEYOR TYPE OF HEARTH.

this chamber fairly cool, the plugs may pass through as slowly as one every 30 sec., whereas when heated up to 1,800

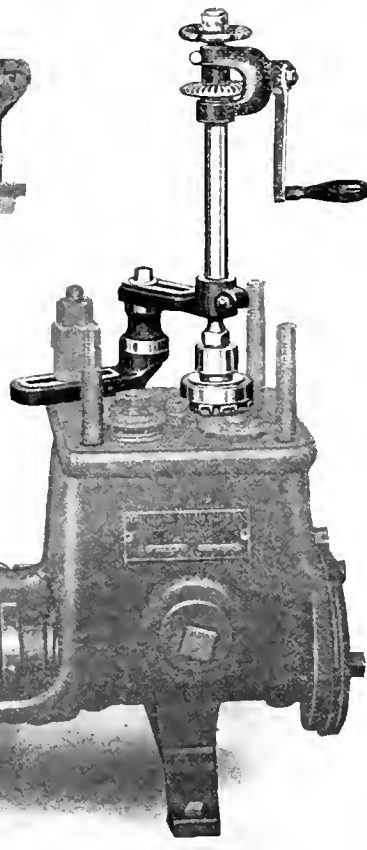

AUTOMATIC TEMPERATURE CONTROL

THE demand for automatic apparatus wherever applicable has led to the development of automatic temperature controllers for gas and oil-fired and electrically-heated furnaces, a comprehensive line of these devices being now manufactured by the Bristol Co., Waterbury, Conn.

The principle on which these new devices are designed is to employ three elements—the measuring element, the contracting element, and the operating element.

The measuring element consists of various types of Bristol electric pyrometers and thermometers. The controlling element is combined with the

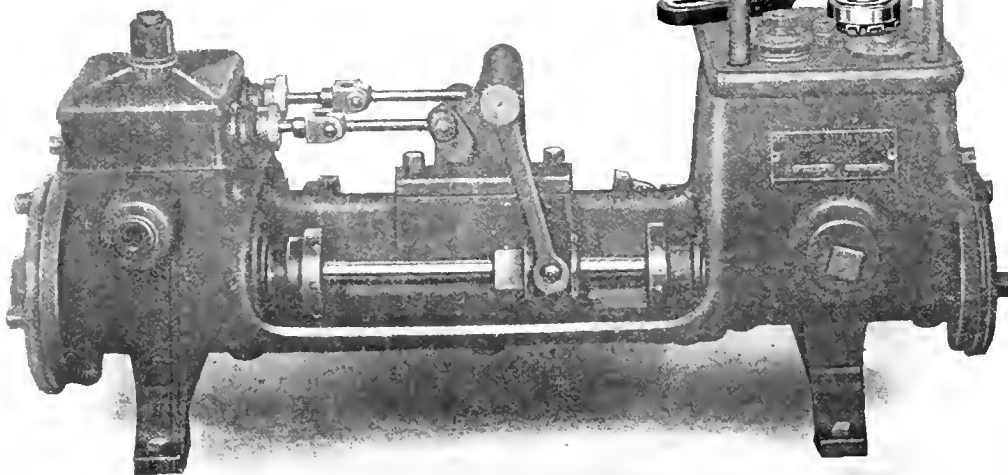

DEXTER SINGLE YOKE PUMP VALVE RESEATING MACHINE REFACING DISCHARGE VALVE SEAT OF DUPLEX STEAM PUMP.

measuring element, and consists primarily of an electrical contact closing device, which operates at predetermined high and low temperatures, thus closing

design of contact closing device shown has proven very practicable and durable in long continued service. Both high and low contacts are shown in this illustration, but when used with the maker's automatic electrical controlling valves for both gas and air supply only one contact is required.

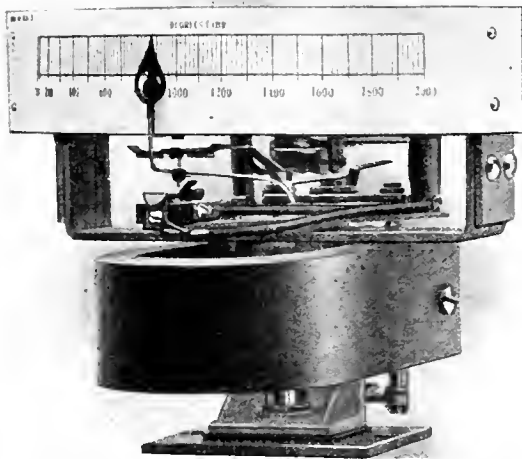

FIG. 1—INTERIOR OF CONTROLLING ELEMENT.

or opening electrical circuits which energize or disconnect the operating element. The interior of the controlling element is shown in Fig. 1, from which it will be seen that the indicating arm is completely insulated from the operating circuits, the contacting device being frictionless. These controllers are furnished for all temperatures up to 3,000 deg. F., with high resistance movements for use either with base or rare metal couples.

The operating element consists of the device which actually regulates the heat supply in the furnace; as, for instance, in the case of a gas-fired furnace, a pair of electrically-operated gas and air valves, and in the case of an electric furnace, it consists of a special relay switch opening and closing the circuits of the heating element of the furnace.

An interior view of a vapor-type thermometer-thermostat is given in Fig. 2, complete with sensitive bulb, this type of instrument being adapted for use

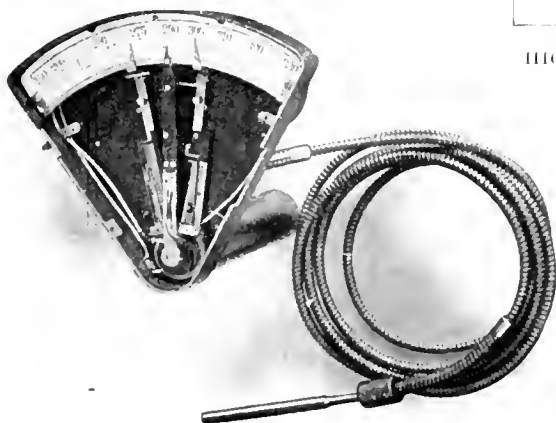

FIG. 2—INTERIOR VIEW OF VAPOR TYPE THERMOMETER-THERMOSTAT.

with a special relay switch, which is used when these instruments are employed for controlling temperatures in electric ovens and furnaces. The special

bushings. The bevel gears are eight-pitch, machine cut, the pinion being of raw hide to insure quiet running at high speeds. The maximum

spindle speed is 2,400 rev. per min. Principal dimensions are: Swing, 10 in.; size of table, 8 x 10 in.; max. distance table to spindle, 14 in.; bed to spindle, 18 in.; spindle dia., 5/8 in.; net weight, 130 lbs.

The Charles Stecher Co., Chicago, are the builders of this machine.

TAPPING MACHINE

THE tapping machine illustrated in the accompanying cuts has been designed and built by the H. E. Harris Engineering Co., Bridgeport, Conn., for the express purpose of overcoming objections to the use of tapping machines which in many cases are productive of broken taps, spoilt and oversize work, etc., most of which can be traced to errors in alignment, inertia of reversing parts, and floating holders. The efforts of the builders have been to preserve the alignment of the tap with the work, reduce the shock of reversing the tap to a minimum, render easy continuous tapping to an exact depth, provide a constant non-slipping drive for the toughest work within its capacity, eliminate "drag" or lengthwise pull on the tap, supply an ample supply of oil to the wearing parts while keeping frictions and belts dry, and make it possible for an inexperienced operator to do good work.

Special attention has been paid to elimination of excessive tap breakage and the production of uniform tapped holes in this machine, at the same time giving maximum production by allowing the operator to use both hands to place and to remove the work, and to use them for this purpose only, making only short rapid movements, the operator being protected from undue fatigue, as he or she may stand or sit in a comfortable position while working, and may shift from one position to another without interrupting the output.

The tapping head is mounted permanently upon the bed, and consists of the tapping head castings, in which are clamped two bearings, one in each pillar. These bearings carry the rotating tapping spindle in their bore, providing an extra long bearing. Externally upon the portions extending inwards from the pillars, they carry the forward and reverse belt pulleys, acting as studs for them to rotate upon and also as a thrust bearing for them. These belt pulleys are bored on the inner surface of the rim to act as the internal members of the tap driving clutches. The external members of the clutch are carried by a spider mounted permanently and centrally on the tapping spindle, and are provided with a slight lengthwise movement with the spindle, to permit change from forward to reverse pulley clutches and vice versa. This clutch spider is made entirely from pure aluminum to insure lightness, and the tapping spindle is of high grade tool steel, so that the diameter may be kept to minimum size and maximum with the least amount of weight. The periphery of this clutch spider is grooved to give cushioning grip

HIGH SPEED BENCH DRILLING MACHINE

THE machine shown in the accompanying illustration has been designed with the object of providing a more convenient and useful article of its kind than has heretofore been offered to manufacturers. The machine itself is a separate unit, and when combined with the bench as shown, it is readily adapted to motor drive, the motor being placed underneath the bench.

The spindle is a steel forging, counterbalanced, and gives very long travel to the drill, having an adjustable stop collar and

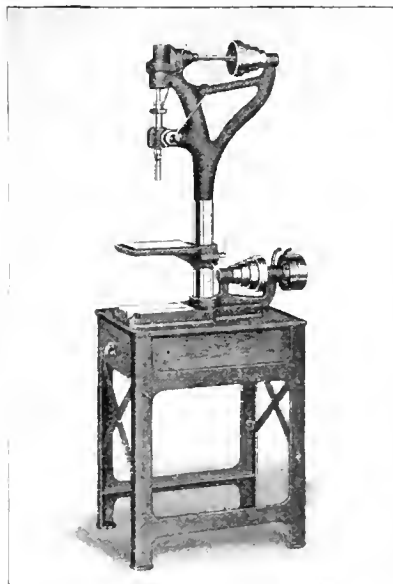

HIGH SPEED BENCH DRILLING MACHINE.

drift hole below the ball thrust bearing. A No. 1 Morse taper hole is provided in the lower end of spindle, while the column, which is well braced to insure stiffness, is well socketed into the base. The base is accurately planed and provided with two tee slots.

No babbitt is used in the construction of this machine, all bearings being fitted with split bronze bushings. The bevel gears are eight-pitch, machine cut, the pinion being of raw hide to insure quiet running at high speeds. The maximum

to the leather friction surfaces, and this grooving also further reduces the weight. The edges are spun up or outwards over the leather so that neither centripetal force nor gravity can cause oil to get on the leather or between the clutch surfaces, the belt pulleys also being so constructed as to carry any oil outward and away from the frictions.

Operation is as follows: Slight pressure on the cutting end of the tap applied by the edge of the hole to be tapped, will cause the spider friction to engage that of the forward drive pulley (at the extreme left in the cut), softly and surely, but with sufficient force to drive the largest tap through the toughest material within the capacity of the machine. When the proper depth is reached and the longitudinal action of the work is stopped, the friction instantly disengages, and the spider with tapping spindle comes to a stop, and slight backward pull on the work engages the reverse drive pulley and clutch (at the right above) just as softly and surely and without shock or undue strain.

Oil cups in the pillar clamps contain and feed oil by suction caused by centripetal action, and by gravity through channels and grooves, to every moving part, insuring ample lubrication. The capacity and location of these channels and grooves are proportioned and positioned to prevent undue waste or spattering of the oil.

On the right, the work carrying head is slidably mounted on the bed to accommodate large or small work and long or short taps. The work is carried in a simple fixture with a taper shank which fits into the sliding work spindle, and is further prevented from turning in the work spindle, by a pin slipping into the notch, shown at the end of the spindle. This spindle is light, being hollow and is prevented from rotating by means of an adjustable clamp dog carrying a hardened steel stud upon which rotates a roller with an intermediate slip bushing to reduce friction. These parts are carefully hardened and ground and work in a hardened and ground channel piece, thus preventing rotation, but permitting lengthwise motion without the retarding friction, or the "drag" of a key when under rotative pressure. This reduces the frictional resistance to the forward or backward movement of the tap to a minimum. Rough adjustments for the size of work, length of the tap and depth of tapping are made by adjusting the whole work carrying head lengthwise on

the bed and by adjusting the clamp dog on the spindle.

Fine adjustment for exact depth is made by the finely threaded hardened steel adjusting screw which is tapped

in the tail stock castings, when the correct depth is reached.



VIEW OF TAPPING MACHINE SHOWING BREAST OPERATED WORK HOLDER.

into the clamp dog and which abuts against a hardened steel stop or button

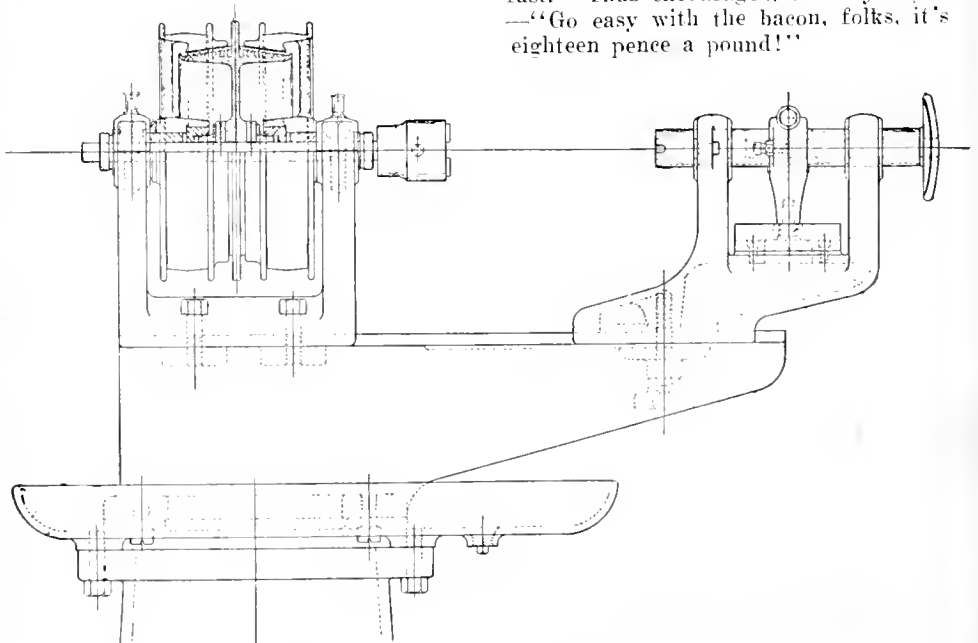

ELEVATION SHOWING DETAILED CONSTRUCTION OF TAPPING MACHINE.

SAFETY VALVE SPRING QUERY

Question.—Please give a formula for finding the size of spring for a safety valve, either round or square steel used.

Answer.—The British Board of Trade rules for spiral springs for safety valve springs are:

$$D = \frac{d^6 \times C}{S}$$

$$d = \sqrt[6]{\frac{S \times D}{C}}$$

$$S = \frac{C \times d^6}{D}$$

where D = diameter from centre to centre of wire in inches (without load).

d = diameter of wire or side of square in inches.

S = load on spring in pounds.

C = 11,000 for square steel spring.

C = 8,000 for round steel spring.

Assuming a valve diameter of 3 3/4 in. to blow off at 200 lbs. pressure and a spring diameter of 3 in. centre to centre, then the load S would be equal to area of 3 3/4 in. dia. valve multiplied by 200, i.e., 11 x 200 = 2200 = S.

The diameter of wire for spring then is

$$d = \sqrt[6]{\frac{2200 \times 3}{8000}} = \sqrt[6]{\frac{6600}{8000}} = \sqrt[6]{.825} = 15-16 \text{ in.}$$

Father's Grace.—War economy has evidently made its need felt in the vicarage as well as in the private house. A clergyman's little son went to stay at a friend's house. The next morning he was asked to say grace. As he hesitated, his host, endeavouring to help, said—"Say what father says before breakfast." Thus encouraged, the boy began—"Go easy with the bacon, folks, it's eighteen pence a pound!"

The MacLean Publishing Company

LIMITED

(ESTABLISHED 1888)

JOHN BAYNE MACLEAN - - - - - President
 H. T. HUNTER - - - - - Vice-President
 H. V. TYRRELL - - - - - General Manager

PUBLISHERS OF

CANADIAN MACHINERY AND MANUFACTURING NEWS

A weekly newspaper devoted to the machinery and manufacturing interests.

PETER BAIN, M.E., Editor. B. G. NEWTON, Manager.

Associate Editors.

A. G. WEBSTER, J. M. WILSON, J. H. RODGERS.

Office of Publication, 143-153 University Avenue, Toronto, Ont.

Vol. XVII. MARCH 15, 1917 No 11.

ACTIVITIES OF IMPERIAL MUNITIONS BOARD TO INCLUDE SHIPBUILDING

JUDGING from the continually expanding and variety-nature activities of what is known as the Imperial Munitions Board, with headquarters at Ottawa, it is quite apparent that not only was the establishment of such a body necessary and desirable, but its individual constituent has been such from a business administrative point of view as to earn the confidence and commendation alike of those whom it serves and the specific enterprise it directs. Its activities in munitions production, have, we make bold to say, had to be piloted into channels of effort little anticipated at its initiation, yet, notwithstanding that a number of quite gigantic undertakings relative to increased shell output have been little more than started, we find the Board's attention being given to the no less urgent call for ships, and preliminary steps being taken whereby Canadian shipbuilding and marine engineering enterprise will find the very widest scope outlet.

The twin industry of shipbuilding and marine engineering—aside from their being taken under the wing of the Imperial Munitions Board, is deserving of more than ordinary attention at this juncture, furnishing as it does the certainty of being the medium whereby the cessation of munitions-making will be minimized in acuteness as regards our metal-working plant operations. Evidences are not wanting that gigantic in proportions as shell-making has actually become, there is no reason to believe otherwise than that the industries of shipbuilding and marine engineering, along with their associated trades and craft may actually transcend the other, and what is doubtless of greatest moment, will have a permanent value as a national asset.

It is officially confirmed, we understand, that the Imperial Munitions Board, with whom negotiations have been in progress for some time past by the executive authorities in Britain, are developing an extensive shipbuilding programme to be filled in Canada, the individual details of which will not only tax the capacity of our already equipped plants, but will necessitate their extension, and the creation of further similar establishments. It is well-known, of course, that there exists meantime a very abnormal dearth of shipping—freight or tramp ves-

sels in particular, and that while Germany's submarine activity curtailed though it be to a great extent, continues, a lessening total tonnage available may be expected.

Notwithstanding the resumption of shipbuilding in Great Britain on a quite generous scale, our losses, both in ships and tonnage, have been enormous; the latter circumstance, however, but serves to demonstrate the fact of our being able to stand the losses, and yet prevail as overseas carriers. There is, nevertheless, a limit to which everything can be strained, individual or national, there is, therefore, wisdom in foreseeing the breaking point well in advance of the latter being reached. At a stage well removed from any real crippling of Britain's merchant fleet, a plan of campaign has been launched, to participate in which—as in men, munitions and money, Canada is invited. James J. Esplen, representative of Britain's Controller of Shipping, is co-operating with the Imperial Munitions Board relative to the placing of vessel contracts and their machinery—propelling and otherwise, while at the same time completing negotiations for the transfer of steel vessels building in Canadian shipyards to foreign order. Progress, we understand, can be reported in both directions.

In recent weeks, not a few corporations have been organized for the specific purpose of constructing steel ships, ranging all the way from 150-footers up to vessels of 7,000 tons, the plant locations covering the coasts of British Columbia, New Brunswick and Nova Scotia. That all of them will find the necessary capital and excellent opportunity for reasonable returns from its investment, may readily be taken for granted. The benefits derivable from the establishment and development of shipbuilding and marine engineering in Canada, of a scope and extent hitherto unknown, have been dealt with in these columns on several occasions, recent and otherwise. The myriad crafts and callings incidental and accessory to each primary enterprise have also been featured. The "way out" from a business depression immediately following the cessation of hostilities is being brought under our observation, in which connection it may not be inadvisable to indicate that there is here a field of productive effort for many of our small engineering concerns now engaged wholly on munitions production. Shipbuilding and marine engineering as exemplified in the finished product—either the combination passenger and freight vessel, or the "tramp," creates opportunity for the manufacture of ship deck machinery, consisting of winches, capstans, windlasses, steering engines, steering gear (hand), etc.; also engine room auxiliaries, which include, pumps, air, feed and circulating; dynamo-engines or ship lighting sets, stop valves, throttle valves, safety valves, sea chests, condensers, piping, lubricators, ash hoists, forced draught and ventilating fans, refrigerating machinery, etc. These, to name but a few of the more prominent accessories of a well-found ship, will serve to indicate a variety of direction in which metal-working plant effort meantime being devoted to shell production may find a waiting opportunity to be taken advantage of.

No apology is necessary for giving special and continued prominence to the matter of Canadian shipbuilding in these columns, feeling as we do that, largely dependent on the attitude we adopt towards it and the nature and intensity of the energy we display to make its outcome worth while, Imperially and nationally, will the business dislocation immediately following the war be nullified.

SELECTED MARKET QUOTATIONS

Being a record of prices current on raw and finished material entering into the manufacture of mechanical and general engineering products.

FIG IRON.

Grey forge, Pittsburgh...	\$31 95
Lake Superior, charcoal, Chicago	35 75
Standard low phos., Philadelphia	56 00
Bessemer, Pittsburgh	36 95
Basic, Valley furnace	30 00
Middlesboro, No. 3	
Cleveland, No. 3	
Clarence, No. 3	
Hamilton	
Victoria	

FINISHED IRON AND STEEL.

Per lb. to Large Buyers Cents

Iron bars, base, Toronto	4 00
Steel bars, base, Toronto	4 25
Steel bars, 2 in. to 4 in. base	5 25
Steel bars, 4 in. and larger base	6 50
Iron bars, base, Montreal	3 95
Steel bars, base, Montreal	4 10
Reinforcing bars, base	4 05
Bessemer rails, heavy, at mill	
Steel bars, Pittsburgh	
Tank plates, Pittsburgh	
Beams and angles, Pittsburgh	
Steel hoops, Pittsburgh	

F.O.B. Toronto Warehouse.

Steel bars, base	4 25
Small shapes	4 75

F.O.B. Chicago Warehouse

Steel bars	3 90
Bars, 2 in. and up	4 40
Structural shapes	4 00
Plates	4 75

FREIGHT RATES.

Pittsburgh to Following Points Per 100 lbs.

Montreal	23.1	31.5
St. John, N.B.	35.1	45.5
Halifax	35.1	45.5
Toronto	18.9	22.1
Guelph	18.9	22.1
London	18.9	22.1
Windsor	18.9	22.1
Winnipeg	64.9	85.1

METALS.

Lake copper	\$43 00	\$40 00
Electro copper	43 00	40 00
Castings, copper	40 00	39 00
Tin	53 00	56 00
Spelter	15 00	14 00
Lead	13 00	12 50
Antimony	34 00	35 00
Aluminum	70 00	68 00

BOILER PLATES.

Plates, 1/4 to 1/2	\$6 50	\$6 50
Heads	6 85	6 85
Tank plates, 2-16 in.	6 10	6 10

WROUGHT PIPE.

Per 100 feet— Black Galv.		
Buttweld.		
1/8 in.	\$ 4 50	\$ 6 00
1/4 in.	2 78	5 91
3/8 in.	3 78	5 91
1/2 in.	4 93	6 50
3/4 in.	6 10	8 22
1 in.	9 01	12 16
1 1/4 in.	12 19	16 45
1 1/2 in.	14 58	19 66
2 in.	19 61	26 46
2 1/2 in.	31 01	41 83
3 in.	40 55	54 70
3 1/2 in.	50 60	67 62
4 in.	59 95	80 12
Lapweld.		
2 in.	22 57	29 05
2 1/2 in.	33 92	44 17
3 in.	44 37	57 76

3 1/2 in.	55 20	72 22
4 in.	65 40	85 57
4 1/2 in.	76 20	99 70
5 in.	88 80	116 20
6 in.	115 20	150 70
7 in.	152 30	196 40
8 L. in.	100 00	206 30
8 in.	184 30	237 60
9 in.	220 80	284 60
10 L. in.	204 80	264 00
10 in.	263 70	339 90

Prices Ontario, Quebec and Maritime Provinces.

WROUGHT NIPPLES.

4" and under, 60%.	
4 1/2" and larger, 55%.	
4" and under, running thread, 40%.	
Standard couplings, 4" and under, 50%.	
4 1/2" and larger, 30%.	

OLD MATERIAL.

Dealers' Buying prices.

Copper, light	\$24 00	\$24 00
Copper, crucible	28 00	28 00
Copper, heavy	28 00	27 50
Copper wire	28 00	28 00
No. 1 machine composition	23 00	22 00
No. 1 composition turnings	19 00	20 00
New Brass clip-pings	18 50	18 00
No. 1 brass turn-ings	15 50	17 00
Steel, low phos.	14 00	18 00
Heavy Melting steel	13 00	16 00
No. 1 machine cast iron	21 00	18 00
Steel turnings	9 00	9 00
Boiler plate	12 00	10 50
Rails	14 75	15 00
Axles, wrought iron	19 00	24 60
Tires, steel	12 00	12 00
Rails	14 75	18 00
Shafting	21 00	20 00
Malleable scrap	10 25	11 00
Pipe, wrought	10 50	9 00
Stove plate	14 00	13 00
Heavy lead	8 00	10 00
Tea lead	6 00	6 50
Scrap zinc	8 50	10 00
Aluminum	36 00	35 00

BOLTS, NUTS AND SCREWS.

Coach and lag screws	30
Stove bolts	35
Plate washers	10
Machine bolts, 7-16 and over	10
Machine bolts, 3/4 and less.	20
Blank bolts	10
Bolt ends	10
Machine screws, fl. and rd. hd., steel	27 1/2
Machine screws, o. and fl. hd., steel	10
Machine screws, fl. and rd. hd., brass	add 20
Machine screws, o. and fl. hd., brass	add 25
Nuts, square, up to 1 in., net list.	
Nuts, hex., up to 1 in., net list.	
Copper rivets and burrs.	30
list plus	30
Burrs only list plus	50
Iron rivets and burrs	27 1/2
Boiler rivets, base 3/4-in. and larger	\$6.35
Structural rivets, as above	6.25
Wood screws, flat, bright	.75
Wood screws, O. & R., bright	.70
Wood screws, flat, brass	.42 1/2
Wood screws, O. & R., brass	.40
Wood Screws, flat, bronze	.35
Wood screws, O. & R., bronze	.22 1/2

MILLED PRODUCTS.

Set screws	35
Sq. & Hex. Head Cap Screws	30
Rd. & Fil Head Cap Screws	10
Flat 3/8 But. Hd. Cap Screws plus	10
Fin. & Semi-fin. nuts up to 1 in.	25
Fin. and semi-fin. nuts, over 1 in., up to 1 1/2 in.	30
Fin. and semi-fin. nuts, over 1 1/2 in., up to 2 in.	10
Studs	20
Taper pins	40
Coupling bolts, plus	10
Planer head bolts, without fillet	10
Planer head bolts, with fillet	10 and 10
Planer head bolt nuts, same as finished nuts.	
Planer bolt washers	net
Hollow set screws	list plus 20
Collar screws	list plus 30, 10
Thumb screws	20
Thumb nuts	65
Patch bolts	add 40, 10
Cold pressed nuts to 1 1/2 in.	add \$4.50
Cold pressed nuts over 1 1/2 in.	add \$7.00

BILLETS.

Bessemer billets	\$65 00
Open-hearth billets	65 00
O.H. sheet bars	65 00
Forging billets	90 00
Wire rods	80 00

NAILS AND SPIKES.

Wire nails	5 00	4 95
Cut nails	4 70	4 70
Miscellaneous wire nails	65%	
Pressed spikes, 3/4 diam., 100 lbs.	4 60	

MISCELLANEOUS.

Solder, strictly	0 33
Solder, guaranteed	0 35
Babbitt metals	.13 to 60
Soldering coppers, lb.	0 53
Putty, 100-lb. drums	3 85
White lead, pure, cwt.	14 25
Red dry lead, 100-lb. kegs, per cwt.	13 87
Glue, French medal, lb.	0 25
Tarred slaters' paper, roll	0 55
Gasoline, per gal., bulk.	0 20 1/2
Benzine, per gal., bulk.	0 29 1/2
Pure turpentine, single bbls., gal.	0 71
Linseed oil, raw, single bbls.	1 40
Linseed oil, boiled, single bbls.	1 43
Plaster of Paris, per bbl.	2 50
Plumbers' oakum, per cwt.	8 00
Packing, square braided	0 27
Packing, No. 1 Italian	0 32
Packing, No. 2 Italian	0 25
Lead wool, per lb.	0 15
Pure Manila rope	0 29 1/2
Transmission rope, Manila	0 37 1/2
Drilling cables, Manila	0 32 1/2

POLISHED DRILL ROD.

Discount off list, Montreal and Toronto	25%
---	-----

CARBON DRILLS AND REAMERS.

S.S. drills, wire sizes up to 52	40
S.S. drills, wire sizes, No. 53 to 80	25
Standard drills to 1 1/2 in.	40
Standard drills, over 1 1/2 in.	15
3-fluted drills, plus	10
Jobbers' and letter sizes	40
Bit stock	40
Ratchet drills	15
S.S. drills for wood	40
Wood boring brace drills	25
Electricians' bits	30
Socketts	30

Sleeves	40
Taper pin reamers	20
Drills and countersinks	list plus 30
Bridge reamers	45
Centre reamers	10
Chucking reamers	10
Hand reamers	15

COLD ROLLED SHAFTING.

At mill list plus 40%
At warehouse list plus 50%

Discounts off new list. Warehouse price at Montreal and Toronto.

IRON PIPE FITTINGS.

Canadian malleable, A, add 10%; B and C, 10%; cast iron, 35%; standard bushings, 50%; headers, 60; flanged unions, 40; malleable bushings, 50; nipples, 55; malleable lipped unions, 50.

SHEETS.

Sheets, Black, No. 28	\$5 50	\$6 15
Sheets, Black, No. 10	6 00	6 00
Canada plates, dull, 52 sheets	5 75	5 75
Canada plates, all bright	7 50	7 50
Apollo brand, 10 1/2 oz. galvanized	7 25	7 25
Queen's Head, 28 B. W.G.	7 75	7 75
Fleur-de-Lis, 28 B.W. G.	7 45	7 35
Gorbals Best, No. 28	8 25	7 50
Colborne Crown, No. 28	8 00	6 75
Premier, No. 28 U.S.	7 75	7 70
Premier, 10 3/4 oz.	8 00	8 00

PROOF COIL CHAIN.

1/4 in.	\$9 45
5/16 in.	9 10
3/8 in.	8 35
7/16 in.	7 15
1/2 in.	6 95
9/16 in.	6 95
5/8 in.	6 80
3/4 in.	6 70
7/8 in.	6 55
1 inch	6 40

Above quotations are per cwt.

ELECTRIC WELD COIL CHAIN B.B.

1/8 in.	\$15 50
3-16 in.	11 70
1/4 in.	8 40
5-16 in.	7 40
3/8 in.	6 35
7-16 in.	6 25
1/2 in.	6 35
5/8 in.	6 35
3/4 in.	6 35

Prices per 100 lbs.

FILES AND RASPS.

Great Western, American	60
Kearney & Foot, Arcade	60
J. Barton Smith, Eagle	60
McClelland, Globe	60
Whitman & Barnes	60
Black Diamond	50
Delta Files	47 1/2
Nicholson	50
Globe	57 1/2
Vulcan	57 1/2
Disston	60

COAL AND COKE.

Solvay Foundry Coke	
Connellsville Foundry Coke	
Yough Steam Lump Coal	8 50
Pittsburgh Steam Lump Coal	8 50
Best Slack	9 00

Net ton f.o.b. Toronto

BOILER TUBES.		TAPES.		ANODES.		SHEETS, 3½ lbs. sq.		
Size.	Seamless	Lap-welded	Chesterman Metallic, 50 ft.	\$2 00	Nickel	.50 to .54	It. 16 00	
1 in.	\$22 00	Lufkin Metallic, 603, 50 ft.	2 00	Cobalt	1.75 to 2.00	16 00	
1¼ in.	25 00	Admiral Steel Tape, 50 ft.	2 75	Copper	.44 to .46	15 50	
1½ in.	29 00	24 00	Admiral Steel Tape, 100 ft.	4 45	Tin	.49 to .56	15 50	
1¾ in.	30 00	22 50	Major Jun. Steel Tape, 50 ft.	3 50	Zinc	.23 to .25	15 50	
2 in.	33 00	23 00	Rival Steel Tape, 50 ft.	2 75	Cut sheets, ½¢ per lb. extra			
2½ in.	35 50	29 50	Rival Steel Tape, 100 ft.	4 45	Cut sheets to size, 1¢ per lb. extra.			
3 in.	46 00	34 50	Reliable Jun. Steel Tape, 50 ft.	3 50	COPPER SHEETS.		PLATING CHEMICALS	
3¼ in.	41 00	WASTE.		Montreal Toronto		Acid, boracic	
3½ in.	53 00	44 00	White	Cents per lb.	Bars, ½ to 2 in.	\$46 00	\$46 00	Acid, hydrochloric
4 in.	65 00	55 00	XXX Extra	20	Plain sheets, 14 oz.	45 00	45 00
Prices per 100 feet, Montreal and Toronto.			Peerless	20	14x2S in., 14x60 m	45 00	45 00	Acid, nitric
OILS AND COMPOUNDS.			Grand	19	Copper sheet, tinned, 14x60, 14 oz.	54 00	54 00	Acid, sulphuric
Castor oil, per lb.	25		Superior	19	Copper sheet, planished, 14x60 base.	57 00	57 00	Ammonia, aqua
Royalite, per gal., bulk	14		X L C R	18	Braziers' in sheets, 6x4 base	46 50	46 50	Ammonium carbonate
Machine oil, per gal.	25½		Atlas	18	BRASS.		Ammonium chloride	
Black oil, per gal.	12½		X Empire	18	Brass rods, base ½ in to 1 in rd.	0 55	Ammonium hydro-sulphuret	
Cylinder oil, Capital	45½		Ideal	17	Brass sheets, 8 in. wide, 20 oz.	0 60	Ammonium sulphate	
Cylinder oil, Acme	36½		X press	16	Brass tubing, seamless	0 55	Ammonium sulphate	
Standard cutting compound, per lb.	0.6		COLORED.		Copper tubing, seamless	0 55	Arsenic, white	
Lard oil, per gal.	1 45		Lion	14½	Polishing wheels, felt	2 10	Copper, carbonate, anhy.	
Union thread cutting oil antiseptic	68		Standard	13	Polishing wheels, bull-neck	1 35	Copper, sulphate	
Acme cutting oil, antiseptic	37½		No. 1	13	Emery in kegs, American	06	Cobalt sulphate	
Imperial quenching oil	39½		Popular	11½	Pumice, ground	04	Iron perchloride	
Petroleum fuel oil	12¾		Keen	10½	Emery glue	15 to 20	Lead acetate	
BELTING—NO. 1 OAK TANNED.			WOOL PACKING.		Tripoli composition	04 to 06	Nickel ammonium sulphate	
Extra heavy, single and double	30-5%		Arrow	25	Crocus composition	07 to 08	Nickel carbonate	
Standard	40%		Axle	20	Emery composition	08 to 09	Nickel sulphate	
Cut leather lacing, No.1	1 50		Anvil	15	Rouge, silver	35 to 50	Potassium carbonate	
Leather in sides	1 35		Anchor	11	Rouge, powder	30 to 35	Potassium sulphide (substitute)	
RUBBER BELTING.			WASHED WIPERS.		Prices Per Lb.		Silver chloride (per oz.)	
Standard	50%		Select White	12	LEAD SHEETS.		Silver nitrate (per oz.)	
Best grades	30%		Mixed colored	10	Montreal Toronto		Sodium bisulphite	
This list subject to trade discount for quantity.			Dark colored	09	Sheets, 3 lbs. sq. ft.	\$16 00	\$16 00	Sodium carbonate crystals
			RUBBER BELTING.		Prices Per Lb. Unless Otherwise Stated.		Sodium cyanide, 127-130%	
			Standard	50%			Sodium hydrate	
			Best grades	30%			Sodium hyposulphite, per 100 lbs.	
							Sodium phosphate	
							Tin chloride	
							Zinc chloride	
							Zinc sulphate	

The General Market Condition and Tendency

PRICES of iron and steel continue very firm, with an upward tendency. Notwithstanding the prevailing high level of prices, further advances on bars, plates and shapes, in the near future, are certain. The expectation of war between the United States and Germany is believed to be the cause of the recent sharp advance in steel products in the American market. In the event of active participation in the war, the U.S. Government would doubtless pre-empt a large tonnage of steel, thus making the situation in the steel trade tighter than ever. This condition would be reflected in the Canadian market by a general rise in prices of steel. The situation in the domestic steel market cannot be said to have improved materially as yet in regard to the fuel supplies. Although receipts of coal, coke and pig iron show some improvement, supplies are not in sufficiently large volume as is required to keep the steel plants operating at or even near capacity. Production of steel during February was seriously curtailed, while the output this month, although perhaps heavier than last month, will be considerably less than at one time anticipated. Foundries are in a better position than they were a few weeks ago, being now able to obtain more pig-iron and coke. The pig-iron market continues very firm and prices are still going up. There is no domestic pig-iron to be had in the meantime, although there may be in the course of two or three weeks. The scrap metal market continues firm, and prices have advanced on some grades of scrap copper, brass, lead and steel. Stocks of cast iron scrap are low, as a result of a big demand, due to the shortage of pig-iron. Prices of all metals are firm, the market, however, is quiet, and business slow. Copper has made a further advance, otherwise prices are unchanged. The machine tool market is quiet, the demand being comparatively light.

Montreal, Que., March 12, 1917.—No marked improvements has been shown in the general situation. Railroad facilities are still taxed to the utmost endeavoring to relieve the congested con-

dition at many points. Good weather is assisting in this matter, but permanent relief is not expected until navigation is opened. The feature of the week is another upward movement in iron and

steel prices. The United States crisis is still delayed, resulting in a continuance of anxiety that has been so pronounced for several weeks.

Pig Iron

The heavy demands for foundry iron, together with the higher cost and scarcity of raw materials, has again been reflected in the higher quotations for the various grades of United States iron. These advances range from \$1 to \$6 per ton, the latter being on Pittsburg foundry, the price asked being \$36.95 per ton. Canadian irons are conspicuous by their absence, all quotations being still withheld.

Steel

An undercurrent of additional strength seems to feature the steel situation. This is largely due to the possibility, in the near future, of the United States Government coming into the field on a war buying basis. The probable result of this action would increase the difficulty, that is at present so pronounced, of Canadian consumers getting supplies from United States mills. Anticipating this contingency, producers in this country are making every effort to offset a scarcity of steel that would handicap the industries at present engaged in munitions and other lines of activity. Higher prices are the feature of the New York market, and further advances are looked for. Furnaces are better supplied with necessary materials, and production is again returning to maximum capacity, but the higher price of coke is reflected. Billets and sheet bars are very firm, and delivery is better. The expected advance on rails has materialized, this week's

quotation being \$55 and \$56 per ton Pittsburg, an advance of \$5 per ton. Activity on the part of implement manufacturers, together with the crowded condition of the mills, has resulted in a further advance on iron and steel bars, the Pittsburg quotation being 31²/_c per lb. No cessation is evident in the abnormal demand for plates, and mills are unable to accept orders under middle of 1918 delivery. This condition has added strength to a very strong market, and an advance of \$20 per ton has been placed on the Pittsburg quotation of tank plates, the present nominal price being 6c per lb. Structural shapes and grooved steel skelp have been advanced \$7 and \$15 a ton respectively. Manufactured steel, including wrought iron pipe and boiler tubes, show an advance, the discount having been reduced two points on W.I. pipe, and on iron tubes 9 points.

The expected advance on wire products has been announced, amounting to \$4 per ton. One-half cent per lb. has been added to proof-coil chain quotations. While dealers here anticipate an early revision of prices, no changes are effective this week.

Metals

The metal situation is still influenced by the submarine menace, but the trade is becoming less anxious as to the future. Transportation difficulties have been partly removed, but freight is still congested. Copper is steady, but with a variable tendency. Tin is firm, with a strong undertone. Spelter is firm, but inactive. Lead has become stronger, and antimony is firm.

Copper.—While quotations are of a variable nature, the general market is comparatively free of feature incidents. Consumers are still influenced by the uncertainty of future conditions, and are only covering their requirements for immediate needs. Reports are abroad that negotiations are on for heavy third-quarter export business, but no confirmation of this is at present available. With the end of the war still in the far distance, there is little likelihood that prices will show any appreciable decline for a long period. London markets are a little easier, but the situation in New York is firm, with a slight advance on electrolytic of 1²/_c, and a decline of 1²/_c on castings. The demand locally is quite brisk, and dealers here are quoting as high as 43c for lake and electrolytic, and 40c for castings, this being an advance of 3c on the former and 1c on the latter.

Tin.—Despite the fact that shipments of tin are daily exposed to the risk of submarine attack, the steady arrival of metal has somewhat restored the confidence of the market, and quotations are generally firm, but strong. However, with the possibilities of loss ever present the situation is marked with a certain degree of nervousness, which would develop into an active upward movement on the sinking of tonnage in transit. Tin is higher both in London and New York, the latter quoting 54c, an advance on the week of one cent per pound. Tin locally has advanced 2c on

a steady market, the nominal quotation being 53c per lb.

Spelter.—The market is steady but inactive. In maintaining the present prices, producers are governed by the high cost of ore and in order to secure a fair percentage of profit, some producers insist that spelter should be higher. Spelter is quiet both in London and New York. Local conditions are unchanged, with prices steady at 15c per lb.

Lead.—Independents have again advanced their quotations the nominal price of 11c representing an advance of 1⁴/_c cent per lb. Dealers here continue to quote 12¹/₂c on a firm market.

Antimony.—Slight activity is noted in futures, but spot metal is quiet. Improved railroad conditions have given relief but the market is generally firm. The situation here is unchanged and firm at 34c per lb.

Aluminum.—The market is very firm. The quotation of 70c is steady and strong.

Machize Tools and Supplies

No feature has developed to change the general situation, and the market continues to reflect the uncertainty prevalent in industrial circles, regarding the early future of all lines of activity. The attitude of the United States government, respecting their decision on the marine policy, has disturbed the general conditions and the trade is awaiting developments. Delivery has improved but is still unsatisfactory. Activity is expected to increase as the spring opens up and the time draws nearer for the placing of additional shell contracts. The further advance of raw materials may result in higher prices in machine tools and accessories.

Scrap

Satisfactory conditions prevail in all lines of scrap. Business is brisk and the volume is quite large. Dealers are taking advantage of the high price of lead and old stock is being unloaded. All classes of old material are very strong on the New York market and the movement is one to higher levels, the exception being in old zinc which is easier. Local changes are confined to coppers and brass, although all metals are quite active. Old copper has advanced 1 cent per lb., the quotation ranging from 24c for light to 28c for heavy scrap. Brass clippings and turnings are 1¹/₂ cent higher, the respective quotations being 18¹/₂ and 15¹/₂c per lb.

Toronto, Ont., March 13.—Trade continues to be remarkably good although manufacturers are still feeling the effects of the scarcity of raw materials. The freight situation while improving is still causing much inconvenience, and shipments are not coming through as quickly as they should be. Locally the fuel shortage has been relieved to a great extent, but some districts are still unable to get sufficient supplies of coal.

The Algoma Steel Corporation may have to close down their plant at the Soo on account of the shortage of coal unless conditions change very materially.

Steel

In spite of the fact that steel prices are considerably higher than they ever have been in the history of the industry, the crest does not by any means appear to have been reached. All indications point to further advances on all iron and steel products, which will be intensified if the United States are drawn into the war, an event which appears highly probable at the present time. Such a climax would result in a heavier demand for steel, and coming at a time when the mills are sold-up for practically the whole of this year, and on some products for longer periods, cannot help but strengthen the situation and possibly lead to a steel famine. That prices on plates and shapes will advance in the near future is practically assured, as the Carnegie Steel Co. has advanced its prices on bars and shapes \$7, and on plates by \$15 per ton. Seamless and lapweld tubes are certain to advance owing to the sold-up condition of the mills. Some makers are sold-up for this year and have also considerable business booked for 1918. Heavy premiums are being paid for fairly prompt shipment of either iron or steel tubes. The demand for ship plates and sections is extremely heavy, being only limited by the ability of the mills to roll the material. The mills are quite unable to cope with the demand for plates coming in from all quarters. The situation is unprecedented, and prices will likely reach a much higher level than now obtains. Prices of wrought pipe have advanced.

Prices of sheets continue very firm with demand for exceeding the supply. Prices are much firmer and further advances are looked for. The railway situation is improving but production is still below capacity. Sheet bars are more readily obtainable but are still higher in price. A further advance in galvanized sheets is also likely.

The steel market in the United States continues very strong and there is every indication of prices going still higher. The advance in bars, plates and shapes, referred to above, indicates the trend of the market generally, and is believed to have been prompted by an expectation of heavy buying by the U.S. Government. The decline in the output of steel in February, which averaged 96,000 tons per day, and was the lowest since August 1915, has not improved the situation. The unfilled orders of the U.S. Steel Corporation on February 28 were 11,576,697 tons, an increase of 102,643 tons over the preceding month. This constitutes a record.

Pig Iron

The situation in the pig iron market is slowly improving on account of the more favorable weather conditions and better transportation facilities. Foundries will now be able to get supplies of

coke and pig iron and thus extend operations. Domestic foundry irons are still off the market, and no quotations can be obtained. The pig iron market in the U.S. is firmer and prices on some grades have advanced. Production is increasing and coke prices are easier.

Scrap

The market continues strong, and higher prices on some old materials have been registered. The shortage of pig iron which has existed for some weeks has caused foundries to take more scrap than usual, with the result that dealers' stocks of cast iron scrap have been almost cleaned up. There has also been a heavier demand for steel scrap resulting in an advance in prices of heavy melting steel and old rails. Some grades of copper scrap have also advanced while heavy lead and scrap zinc are higher. The following new prices are now in effect. Heavy copper 27½¢; copper wire, 28¢; No. 1 machine composition, 23¢; No. 1 brass turnings 17¢; heavy lead 10¢, and scrap zinc 10¢ per pound, heavy melting steel \$16; No. 1 machine cast iron \$10; and steel rails \$18 per ton.

Machine Tools

There have been no developments of importance to note in the machine tool market, business for the most part consists of orders for single tools for munitions plants.

Supplies

Prices of machine shop and mill supplies continues to advance, with business brisk. American makers of lathe chucks have advanced their prices, new discount being list plus 50 per cent., as against list plus 30 per cent. formerly. A further advance of approximately 10 per cent. has been made in the price of globe, angle and check valves. Standard lines now carry a discount of 15 per cent. high grade 10 per cent., and medium pressure 40 per cent.

Metals

The situation in the metal market has not changed much during the past week. Owing to the unsettled outlook, business is dull, any pronounced activity is not looked for until the political situation clears up. That is to say, if war were declared between the United States and Germany, it would relieve the present tension and an active market would result. The feature of the market is the continued advance in copper which has touched a new high level. Quotations on other metals are unchanged but firm. Business locally is very good but a scarcity of copper is reported.

Copper.—The copper situation shows very little change although the price has advanced and is still nominal. The metal is very scarce for all deliveries over the first half, but the demand continues light and the market quiet. The position of copper will be a strong one while the war lasts, and there is no indication at present of any recession in price. Copper has advanced 1¢ and is quoted at 40¢ per pound for lake and

electrolytic, and 39¢ for eastings copper.

Tin.—The market is quieter but prices continue firm and unchanged. The market is still being affected by the submarine menace, but not so much as formerly. Supplies of tin continue to come across in steady volume but the demand is small. Local quotations 56¢ per pound.

Spelter.—The situation in the spelter market is unchanged and the price stationary. The demand is light and market quiet. Local price 14¢ per pound.

Lead.—The market is well sold ahead, there being very little lead left for March or April delivery. The market continues strong and prices unchanged at 12½¢ per pound.

Antimony.—There is still some scarcity of antimony but the market is easier and unchanged at 35¢ per pound.

Aluminum.—The demand for aluminum has improved but supplies are lower. The market is firm and unchanged at 68¢ per pound.

CANADIAN GOVERNMENT PURCHASING COMMISSION

The following gentlemen constitute the Commission appointed to make all purchases under the Dominion \$100,000,000 war appropriation:—George F. Galt, Winnipeg; Hormidas Laporte, Montreal; A. E. Kemp, Toronto. Thomas Hilliard is secretary, and the Commission headquarters are at Ottawa.

SAWMILL MACHINERY WANTED IN RUSSIA.

THE Canadian Trade Commissioner in Russia has written an interesting report to the Department of Trade and Commerce at Ottawa, drawing attention to the prospective openings for mill equipment and supplies for Canadian manufacturers in the northerly districts of Russia. He says: "The forest wealth of northern Russia constitutes one of the greatest undeveloped assets of the Empire. In the Governments of Archangel, Vologda, Olonetz, Viatsk and Tobolsk there are some ninety million dessiatines (243 million acres) of almost untouched forests of commercial timber, exploitation of which has become now an economic necessity dictated by the need of improving the balance of trade in Russia's favor and of raising the value of the rouble.

"Conferences have taken place recently between the Secretary of State for Domains and all the northern timber exporting firms and sawmill proprietors, for the purpose of concerting measures for a program of development calculated to secure satisfactory results, and which at the same time will insure the opening up of these northern districts. It is assumed that a market for the timber will be

found in the allied countries, chiefly for the rebuilding of the devastated districts of Belgium and France, and to a less extent, in the United Kingdom.

Twenty Million Logs Annually

The Domains Ministry estimates the possibility of obtaining an annual cut of twenty million logs, or approximately one million standards of sawn goods. It seems doubtful whether the present means of production in the regions in question are capable of dealing immediately with so large an annual cut. An enlargement of the existing mills, and the creation of new sawmills will be necessary, as well as the establishment of other industrial concerns using wood as their raw material for the manufacture of mechanical and chemical wood pulp, paper, wooden ware, matches, sashes and doors, moulding, etc. It is regarded as essential for the end in view, that as little as possible of Russian timber should be exported in an unmanufactured state.

Resolutions Passed by Conference.

A number of resolutions were adopted by the conference regarding the opinion that the estimate of twenty million logs could be handled by Russian capital and Russian labor, and that the granting of concessions to foreigners should not take place; that a new federation or syndicate comprising all the timber exporters in northern Russia be created, to whose members small concessions be made, the terms of such concessions to run from three to twelve years for the production of sawn goods, and up to thirty-six years for the production of pulp. In the latter case suitable districts to be selected and waterpower to be given free; that all logs sold from the Government forests be sold exclusively to the new federation, which would itself take over the direct sales to the representatives of the Allied Governments, and that no Government monopoly be created; that members of the federation be entitled to import duty free the machinery and materials required for the extension of existing mills and for the creation of new ones; that employees be treated as working for the defence of the State and therefore not to be called up for military service.

Where Canada's Interest Lies.

"Canada's interest in these proposals will be solely in the ability of her manufacturers to participate in the supply of the sawmill machinery equipment, wood-working machine tools as well as the mill and factory supplies that will be required, all of which may be said to be our particular specialties. There will be openings also in other directions, as the development contemplated will call for much contracting work, as well as machinery for widening and deepening canals, for river improvements, the provision of a large complement of tugs and barges and for general supplies of great variety.

There Will be Competition.

"It need hardly be emphasized that in connection with such openings the personal investigation by Canadian manu-

Enlarged Canadian Trade Intelligence Service

Under the arrangement made by the Minister of Trade and Commerce with Sir Edward Grey in July, 1912, the Department of Trade and Commerce, Ottawa, is able to present the following list of the more important British Consulates whose officers have been instructed by the Foreign Office to answer inquiries from and give information to Canadians who wish to consult them in reference to trade matters.

BRAZIL—Bahia, British Consul. Rio de Janeiro, British Consul General.	NETHERLANDS—Amsterdam, British Consul.
CHILE — Valparaiso, British Consul General.	PANAMA—Colon, British Consul. Panama, British Vice-Consul.
COLOMBIA — Bogota, British Consul General.	PERU—Lima, British Vice-Consul.
ECUADOR—Quito, British Consul General. Guayaquil, British Consul.	PORTUGAL—Lisbon, British Consul.
EGYPT — Alexandria, British Consul General.	RUSSIA—Moscow, British Consul General. Petrograd, British Consul. Vladivostock, British Consul. Odessa, British Consul General.
FRANCE—Havre, British Consul General. Marseilles, British Consul General.	SPAIN—Barcelona, British Consul General. Madrid, British Consul.
INDIA—Calcutta, Director General of Commercial Intelligence.	SWEDEN—Stockholm, British Consul.
ITALY—Genoa, British Consul General. Milan, British Consul.	SWITZERLAND—Geneva, British Consul.
MEXICO—Mexico, British Consul General.	URUGUAY—Monte Video, British Vice-Consul.
	VENEZUELA — Caracas, British Vice-Consul.

Canadian Commercial Intelligence Service

The Department of Trade and Commerce invites correspondence from Canadian exporters or importers upon all trade matters. Canadian Trade Commissioners and Commercial Agents should be kept supplied with catalogues, price lists, discount rates, etc., and the names and addresses of trade representatives by Canadian exporters. Catalogues should state whether prices are at factory point, f.o.b. at port of shipment, or, which is preferable, c.i.f. at foreign port.

CANADIAN TRADE COMMISSIONERS.

ARGENTINE REPUBLIC—H. R. Poussette, Reconquista, No. 46, Buenos Aires. Cable address, Canadian.
AUSTRALIA—D. H. Ross, Stock Exchange Building, Melbourne. Cable address, Canadian.
BRITISH WEST INDIES—E. H. S. Flood, Bridgetown, Barbadoes, agent also for the Bermudas and British Guiana. Cable address, Canadian.
CHINA—J. W. Ross, 13 Nanking Road, Shanghai. Cable address, Cancom.
CUBA—Acting Trade Commissioner, Lonja del Comercio, Apartado 1290, Havana. Cable address, Cantracom.
FRANCE—Phillipe Roy, Commissioner General, 17 and 19 Boulevard des Capucines, Paris. Cable address, Stadacona.
JAPAN—G. B. Johnson, P. O. Box 100, Yokohama. Cable address, Canadian.
HOLLAND—Acting Trade Commissioner, Zuidblaak, 26, Rotterdam. Cable address, Watermill.
RUSSIA—C. F. Just, Canadian Government Commercial Agent, Alexandriyskaya, Ploshch 9, Petrograd. L. D. Wilgress, Canadian Government Commercial Agent, Bukhgozla Ulitza No. 4, Omsk, Siberia.
NEWFOUNDLAND—W. B. Nicholson, Bank of Montreal Building, Water Street, St. John's. Cable address, Canadian.
NEW ZEALAND—W. A. Beddoe, Union Buildings, Customs Street, Auckland. Cable address, Canadian.
SOUTH AFRICA—W. J. Egan, Norwich Union Buildings, Cape Town. Cable address, Cantracom.
UNITED KINGDOM—Harrison Watson, 73 Basinghall Street, London, E.C., England. Cable address, Sleighbing, London. N. D. Johnston, Sun Building, Clare Street, Bristol. Cable address, Canadian. J. E. Ray, Central House, Birmingham. Cable address, Canadian. J. Forsyth Smith, 27-28 Pearl Building, East Paradise, Leeds. Cable address, Canadian. F. A. C. Blekerdike, Canada Chambers, 36 Spring Gardens, Manchester. Cable address, Cantracom. J. T. Lithgow, St Union Street, Glasgow, Scotland. Cable address, Cantracom.

SPECIAL TRADE COMMISSIONER—LUMBER

H. R. McMillan, visiting Europe, Africa, Australasia and the Orient.

CANADIAN COMMERCIAL AGENTS

AUSTRALIA—B. Millin, Exchange Building, Sydney, N.S.W.
BRITISH WEST INDIES—Edgar Tripp, Port of Spain, Trinidad. Cable address, Canadian. R. H. Curry, Nassau, Bahamas.
NORWAY AND DENMARK—C. E. Sontum Grubbedged No. 4, Christiania, Norway. Cable address, Sontums.

CANADIAN HIGH COMMISSIONER'S OFFICE

UNITED KINGDOM—W. L. Griffith, Secretary, 17 Victoria Street, London, S.W., England. Cable address, Dominion, London.

facturers or of their expert representatives is indispensable, if practical results are to follow. Probably the opening of a bureau of information on joint account in Petrograd for dealing with such matters would meet the situation most effectively. The present occasion, for instance, would provide the opportunity for introducing the most up-to-date methods of Canadian sawmill practice, especially the use of band-saw machinery as against the reciprocating frame saw for dealing with the large size timber of these virgin forests; inquiry into questions relating to financial and exchange matters, credit terms and Russian business methods generally. All these matters can only be studied and considered adequately by personal contact with the interests concerned and it is only upon their proper settlement that the foundation of broad and permanent trade relations can be established between the two countries. The Russian responds very readily to new methods which have proved their usefulness in countries like Canada, where the conditions and climate so closely resemble his own. In the past Norway and Sweden have supplied much of the equipment of Russian and countries will undoubtedly be our keen Finnish timber industries, and these competitors in the future, but there should be room for all."

SUBMARINE MENACE BEING COMBATED

OFFICIAL figures from the British Admiralty, made public in New York, a few days ago at the office of the Consul-General of Great Britain, show that during February 94 British merchant ships were destroyed by mines or submarines. Of this number, 61 ships were of 1,600 tons or over. In addition to merchant ships, 29 fishing vessels of British register were sunk. During the month, and up to March 4, 67 British merchant vessels were unsuccessfully attacked by submarines. The number of merchant vessels of all nationalities, over 100 tons each and exclusive of local or fishing craft, which arrived at and departed from British ports were as follows: Arrived, 9,463; sailed, 9,124; total, 18,587. More than 2,000,000 tons of shipping is now on the stocks in various shipyards, all in more or less advanced stages of construction. "The general situation," the Admiralty announced, "is considered quite satisfactory."

Trade Inquiries

THE Department of Trade and Commerce, Ottawa has received the following enquiries:—

545. Engineers' Tools.—An old-established engineering firm in Barbadoes makes inquiry for Canadian tools.

548. French Agency.—A French civil engineer in Paris desires to secure agencies from Canadian manufacturers of steel, electrical motors, machine tools, machinery and general supplies for factories.

INDUSTRIAL ^A_N^D CONSTRUCTION NEWS

Establishment or Enlargement of Factories, Mills, Power Plants, Etc.; Construction of Railways, Bridges, Etc.; Municipal Undertakings; Mining News

ENGINEERING

Montreal, Que.—The Stowell Screw Co. will build a factory at Longueuil.

Hamilton, Ont.—The Dominion Steel Foundry, Ltd., will build an addition to their plant, to cost \$27,000.

Shawinigan Falls, Que.—The Belgo-Canadian Pulp and Paper Co. are building an addition to their mill here.

Montreal, Que.—The Montreal Locomotive Co. will extend their plant. Four separate buildings will be erected at a total cost of \$5,900.

St. John, N.B.—The C. P. R. propose erecting a 40,000-gallon steel water tank at Bay Shore. A new 60,000-gallon steel water tank will be set up at Jackman, Maine, and a 40,000-gallon vessel will be provided at Holyoke, Maine.

Three Rivers, Que.—The Mechanical Engineering Co., of Montreal, are building a new factory here, to cost about \$100,000. The plans include a large machine shop, which will be equipped with new machinery.

Brantford, Ont.—Mickle, Dymont & Son have entered the toy industry and have completed a shipment to Toronto of a carload of new wooden construction model sets. Two local firms are now outfitting imported toys from the Canadian market, and preparing for the time when German products will again come into the market.

Halifax, N.S.—Development of the water-power of the Gaspereau River is not to be undertaken, for the present at least, by the Nova Scotia Tramways & Power Co. The tidal forces at Cape Split or the development of hydro-electric powers elsewhere are to be awaited before expenditures are made on the Gaspereau proposition.

Haileybury, Ont.—The big power development scheme being under construction at Gowganda by the South Bay Power Co. is now under way. The construction of a dam six hundred feet long at Hanging Stone Falls is to be rushed and completed before the spring break-up. One initial unit with a capacity of five hundred horsepower will be installed.

MUNICIPAL

St. Thomas, Ont.—The Town Council contemplate installing a sewage disposal plant.

Swift Current, Sask.—The City Council contemplate purchasing a 615 h. p. oil engine.

Montreal, Que.—Nineteen tenders have been submitted to the Board of Control for the supply of ten motor sprinklers and the same number of sweepers, which the city plans to buy.

The prices ranged from \$5,500 to \$9,700 per machine.

Winnipeg, Man.—Over \$12,000 is to be spent on repairs and improvements to city incinerators used in the destruction of garbage and other refuse. W. P. Brereton, city engineer, reported to the Board of Control that to instal the new pre-heater at Elgin Avenue would cost \$5,750. The concrete chimney, to replace that recently taken down at Elmwood incinerator, is expected to cost \$6,500.

Toronto, Ont.—Mr. Proctor, assistant to Engineer James, has submitted a report to the Etobicoke Township Council relative to the Islington, Lambton and Long Branch water scheme. With regard to Long Branch, it is proposed to bring water from New Toronto, necessitating the installation of new mains from that municipality. No action was taken by the council. The engineer will submit the details and estimates of the proposition to the ratepayers in the near future.

ELECTRICAL

Montreal, Que.—The Montreal Tramways Co., are building a sub-station on Cote Street.

Brockville, Ont.—The Hydro-Electric Commission will prepare new plans with reference to Brockville, and these are to be submitted in two weeks for the examination of the Public Utilities Commission of the town.

GENERAL

Woodstock, Ont.—The Harvey Knitting Co. will build an extension to their factory here.

Goderich, Ont.—The Doty Co. plant will be taken over by W. H. Hutchinson, of St. Catharines, and R. A. Pringle, of Ottawa.

London, Ont.—The City Council have granted the McClary Mfg. Co. permission to lay a gas main to the city limits to connect with the Southern Counties Gas Co.'s line.

Windsor, Ont. It was announced here that Brener Brothers, of London, one of the largest manufacturers of cigars in Western Ontario, will shortly begin the erection of a five-storey building in this city, to be used by them as a factory. The building will cost \$75,000, and will be located at London street and Dougall avenue.

TENDERS

London, Ont.—The County Council of Middlesex are in the market for a 10-ton steam road roller. Tenders received

until March 22. John Stuart, county clerk.

Toronto, Ont.—Tenders, addressed to the chairman of the Toronto Electric Commissioners, will be received until March 28 for synchronous condensers. Specifications may be obtained at the office of the purchasing agent, 15 Wilton Avenue, Toronto.

Sherbrooke, Que.—The City Council is receiving tenders for approximately 7,000 feet of galvanized iron pipe, from ¾-inch to 1¼ inch, together with fittings, valves from ½ inch to 8 inches, 10 tons pig lead, lead wool, packing, etc. Purchasing agent, H. C. King.

Yorkton, Sask.—Tenders are being received for the following: One 357 h.p. oil engine, one 280 k.w. generator, one transformer down to 30 k.w., 450 feet of 4-inch cast iron pipe, 200 pounds of lead. Further particulars from F. J. Pilkington, town clerk.

Toronto, Ont.—Tenders will be received up to April 2, addressed to the chairman of Toronto Harbor Commissioners, 50 Bay Street, Toronto, for the construction of harbor head walls. All information may be obtained by applying to the above address. E. L. Cousins, chief engineer and manager.

Toronto, Ont.—Tenders for Synchronous condensers, addressed to the chairman of the Toronto Electric Commissioners, will be received until March 28. Specifications, form of tender and all information desired may be obtained at the office of the purchasing agent, 15 Wilton Avenue, Toronto.

Quebec, Que.—Tenders, addressed to the secretary-treasurer of the Municipality of Halifax-South, will be received until March 25, for the construction of two highway bridges, with steel superstructure, concrete abutments, approaches, etc., on the Frontier and Pigeon Rivers (ten arpents distant) in the Parish of St. Ferdinand d'Halifax, Megantic County. Plans and specifications may be examined at the Council's Office and at the Department of Public Works and Labor, Quebec.

Ottawa, Ont. Under direction of the Hon. the Minister of Militia and Defence the following old stores are for sale by public tender: Metal, old brass, 94 lbs.; copper, 24 lbs.; iron cast, 5,640 lbs.; iron galvanized, 234 lbs.; iron, wrought, 735 lbs.; lead, 870 lbs.; steel files, 26 lbs.; steel scrap, 1,105 lbs.; tin, 96 lbs. The above mentioned stores may be seen on application to the Senior Ordnance Officer, Winnipeg. Sealed tenders for the purchase of any or all of the lots addressed to the above mentioned officer will be received until March 20, 1917. Eugene Fiset, Deputy Minister, Militia and Defence, Ottawa.

BUILDINGS

Three Rivers, Que.—Lymburners, Ltd., of Montreal, are building a munitions factory here.

Windsor, Ont.—The Heintzman Piano Co. will make an addition to their building here. T. C. Pennington Labelle is the architect.

Montreal, Que.—The Steel Company of Canada has obtained a permit to erect a building on Notre Dame Street West, St. Joseph's Ward, to cost \$1,200.

Kingston, Ont.—The Chancellor of Queen's University, Dr. James Douglas, of New York, has agreed to give \$100,000 towards a fund to develop the Kingston General Hospital into a capacious modern institution.

Montreal, Que.—Permits were taken out in February for the erection of buildings to a total of \$3,588,600 and permits were taken out in the same month to make repairs to cost \$43,965. There was a falling off in the number and value of permits taken out in the last week of the month.

Toronto, Ont.—At a recent session of the Etobicoke Township Council the trustees of School Sections No. 3, Etobicoke, and No. 24, York, both in Lambton, asked for a grant of \$4,000 to complete their school buildings. The council approved of the request, and debentures will likely be issued for that amount.

Winnipeg, Man.—T. H. Johnson, Minister of Public Works, announced in the Legislature on March 5 that the contract for the completion of the Parliament Buildings would be let to the J. McDiarmid Construction Co., at \$1,785,681.17. Plumbing, heating and electric-wiring contracts will bring the total for the work. Other tenders were put in by G. A. Fuller Co., Montreal, and W. Cowlin Co., Toronto.

PERSONAL

Captain James Warwick, a well known marine man, passed away at Courtright, Ont., on March 11. Deceased was 72 years of age.

Fraser S. Keith, B.Sc., for the past eighteen months editor of "Construction" has been appointed secretary of the Canadian Society of Civil Engineers, Montreal, in succession to Professor C. H. McLeod, resigned.

Corp. Robert John Dawson, of the P.P.C.L.I., has been killed in action. Corp. Dawson went overseas with the 3rd University Company. Prior to enlisting he was engaged as a salesman for the Canadian Fairbanks-Morse Co., Front Street, Toronto.

CONTRACTS

Ottawa, Ont.—The City Council has awarded a contract for valves to the Drummond McCall Co., Montreal.

Lindsay, Ont.—A contract has been awarded by the Town Council to the Norwood Eng. Co., Sherbrooke, Que., for

filters and accessories at a contract price of \$21,500.

Pembroke, Ont.—The Pembroke Electric Light Co. has awarded the following contracts, for a 1800h. p. horizontal turbine. The Boying Hydraulic and Engineering Co., Lindsay Ont.; generator, transformer and switchboard, the Canadian Westinghouse Co., of Hamilton.

INCORPORATIONS

Santoline, Ltd., has been incorporated at Toronto with a capital of \$40,000 to manufacture soap, greases and disinfectants, etc., at Toronto. Provincial directors are D'Arcy G. Grierson, James Bell and Richard Davis, all of Toronto.

Dodge Brothers Motor Co. has been incorporated at Ottawa with a capital of \$100,000 to manufacture and deal in motor cars and trucks, etc., at Windsor, Ont. The incorporators are John F. Dodge, Horace E. Dodge, and Fred Y. Haynes, all of Detroit, Mich.

The Signal Motor Truck Co., of Canada, Ltd., has been incorporated at Toronto with a capital of \$50,000 to manufacture motor trucks and automobiles at Toronto. The provisional directors are John S. McLaughlin, Fred E. Earl and James McFadden, all of Toronto.

Atlantic Pulpwoods Ltd., have been incorporated at Quebec, with a capital of \$500,000 to build and operate paper and pulp mills. The head office is at Montreal, and the incorporators are Charles N. Blackeley, Charles M. Cotton and Frederick T. Enright, all of Montreal.

Angus Power Co. has been incorporated at Ottawa with capital of \$500,000 to carry on the business of electricians and mechanical engineers, also to construct and operate power plants. Head office is at Montreal, and the incorporators are: Errol Languedos, Jean P. Charbonneau and Ralph E. Allan, all of Montreal.

WOODWORKING

Collingwood, Ont.—Fire on March 6, destroyed the planing mill of the Wilson Mfg. Co., entailing a loss of over \$100,000, largely covered by insurance.

Danville, Que.—The factory and warehouse of the Danville Chair Co., was destroyed by fire recently, the machinery and contents being a complete loss. The total loss is estimated at \$50,000.

RAILWAYS—BRIDGES

Hamilton, Ont.—The Board of Control has decided to engage W. F. Tye, railway engineer, Montreal, providing satisfactory terms can be arranged, to report on the most feasible common entrance for all railways desiring to enter Hamilton from the west.

Haileybury, Ont.—The car barns of Nipissing Central Railway, North Cobalt, partly destroyed by fire on March 4. Five cars were completely demolished, but the transformers and three cars were saved. The damage to the building is estimated at \$40,000, the five cars at

\$60,000 and electrical equipment \$30,000 making a total loss of \$130,000.

MARINE

Victoria, B. C.—Three of the 260foot auxiliary schooners building at Victoria and North Vancouver in the shipyards of the Wallace concern and the Cameron-Genoa Mills Shipbuilders Ltd., will be in the water by March 19. The third vessel Laurel Whalen will be launched on that date.

Vancouver, B.C.—A new order for three big steel steamers has been placed by the British Government with John Coughlan & Sons, of this city. They will be 8,800-ton ships of the same size and design as those being constructed under the order for the three boats by a Norwegian syndicate with the same firm.

St. John N. B.—At the monthly meeting of the Board of Trade held on March 6, it was decided that both the Federal and Provincial Governments be memorialized by the Board of Trade in the matter of shipbuilding, and that some kind of bonus and a definite scheme be laid down for the encouragement of this industry.

Victoria, B. C.—In addition to the two car barges which are about to be built for the C. P. R. the contracts for which are expected to be let in the course of the next few days, Capt. J. W. Troup, manager of the B. C. Coast service, announced that the company intended to call for immediate tenders for the construction of a 1200-ton capacity freight barge which will be used for general freight purposes.

Navigation Will Open Late.—Reports are unanimous in the opinion that navigation this year will be at least two weeks late in starting. Heavy ice is reported everywhere, with considerably more of it than a year ago. In Buffalo harbor thirty inches of ice is reported, and vessels with storage grain are experiencing considerably difficulty in working their way to elevators. In Lake Erie the ice field extends beyond view and is from 15 to 20 inches in thickness.

TRADE GOSSIP

B. C. Sulphuric Acid Plant.—Trail smelter's sulphuric acid plant has been operating steadily since last July and is turning out its regular quota of acid which makes it possible to operate the several refineries in connection with the works—lead, copper, zinc and slimes. A. L. McCallum is the superintendent.

U.S. Steel Orders.—The unfilled orders of the U.S. Steel Corporation on February 28 were 11,576,697 tons, breaking all previous records. The figures showed an increase of 102,643 tons over the report for January 31st, last. The previous high record was that for December 31st, 1916, when the unfilled orders stood at 11,547,286 tons.

Cunard Orders Placed in Seattle.—The Ames Shipbuilding & Drydock Co., of Seattle, have signed contracts to build

“WILLIAMS” STOCK LIST

ELECTRIC MOTORS

In Stock for Immediate Delivery

No.	H.P.	Speed	Phase	Cycle	Volt.	
6	5	750	3	25	550	new
2	5	750	3	25	550	used
2	20	750	3	25	550	new
1	10	750	3	25	550	new
2	10	750	3	25	550	used
1	40	750	3	25	550	used

We also have a stock of Dumore tool Post Grinders, Electric Drills and a number of other labor-saving electric specialties.

Write us.

Phone Motor Dept., Adel. 20

The A. R. Williams Machinery Co., Limited

64-66 FRONT STREET WEST

TORONTO

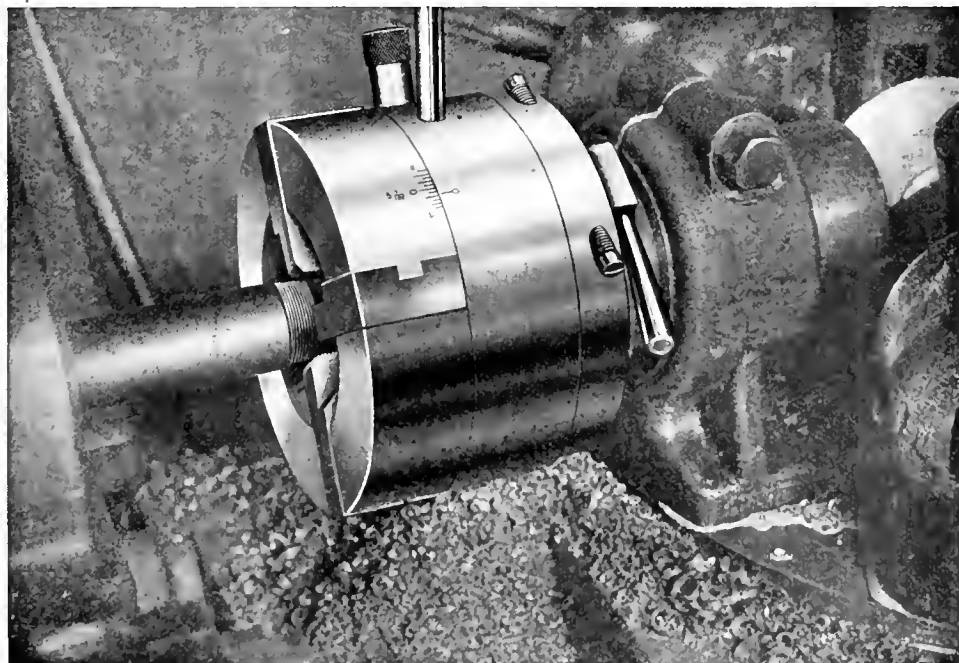

This Geometric Die Head is threading a malleable iron casting, on a Jones & Lamson Machine, in the plant of the Detroit Gear & Machine Co., where they make transmission and internal drive rear axles.

Have you investigated the merits of the Geometric Self-opening and Adjustable Die Heads? It will cost you nothing to get our quotation on your specifications.

The Geometric Tool Company, New Haven, Conn., U.S.A.

Canadian Agents:

Williams & Wilson, Ltd., Montreal. The A. R. Williams Machinery Co., Ltd., Toronto, Winnipeg, St. John, N.B.

If any advertisement interests you, tear it out now and place with letters to be answered.

PATENT ATTORNEYS

BABCOCK & SONS

ESTAB. 1877

PATENTS-TRADE MARK-DESIGNS
IN ALL COUNTRIES

Book "Patent Protection"—free. Master of Patent Laws. Formerly Patent Office Examiner.

99 St. James St., - Montreal, Que.
Branches: Ottawa, Washington.

RESEARCH BUREAU

REPORTS BY EXPERTS ON SCIENTIFIC, TECHNICAL AND INDUSTRIAL DEVELOPMENT.

SPECIAL RESEARCHES ARRANGED.

PATENTS, TRADE MARKS, ETC.

HANBURY A. BUDDEN CABLE ADDRESS
712 DRUMMOND BLDG., MONTREAL "BREVET"

PATENTS

Fetherstonhaugh & Co.
Patent Solicitors. Head Office,
Royal Bank Bldg., Toronto.
Ottawa Office, 5 Egin St.
Send for our Plain Practical
Pointers. Copy of National
Progress, in which our patents
are advertised, mailed free.

PATENTS PROMPTLY SECURED

In all countries. Ask for our Investor's Adviser, which will be sent free.

MARION & MARION, 364 University St.
Merchants Bank Building, corner
St. Catherine St., MONTREAL, Phone Up. 6474
and Washington, D.C., U.S.A.

SPECIAL MACHINERY

GAUGES, FIXTURES, DIES
AND
PRECISION TOOLS

WE HAVE THE
MOST MODERN
EQUIPMENT
TO HANDLE
ANY CLASS OF WORK

CANADIAN DISTRIBUTORS FOR THE
**ALBANY PATENT ROTARY
PUMP**

Albany Pump Co.

16 Pearl St., TORONTO, Canada
Phone Ad. 2511 A. W. Bennet, Manager

nine large steel steamships at a cost of more than \$11,000,000. Seven ships of 9,000 tons each for the Cunard Line are among the boats. Keels for the first three Cunarders will be laid during the present month.

Canada's Fire Loss Heavy.—Canada's fire loss during February, was \$2,009,953, compared with \$1,918,660 in January, and \$3,275,600 in February, 1916. The city of Quebec is unenviably prominent reporting four important fires during the month with loss totalling \$400,000. Individual fires entailing a loss of \$100,000 or more also occurred in Hamilton and Winnipeg.

The Mechanical Engineering Co., Montreal, are moving their business to Three Rivers, Que. The new factory will be of brick construction with concrete floors and columns. The plant will be modern in every way and cost approximately \$100,000. A large machine shop will be the most important feature of the plant, where new machinery will be installed. Mr. Barrie is the superintendent.

Further Trade Restrictions.—According to a cable received from the British Board of Trade at the Montreal office of H. M. Trade Commissioner for Canada, further restrictions of exports from Great Britain have been made.—These include copper manufactures, telegraphers and telephones, various implements for munitions foodstuffs starch, refined tallow, albumen, casein, and dextrine.

Demand for Ships on Atlantic.—So great has been the demand for vessels on the Atlantic seaboard during the last year that 71 Great Lakes steamers, with a total tonnage of 683,770 tons, have been transferred to deep-water service. These vessels are now all operating out of Atlantic Coast ports, according to advices from the East. In Great Lakes shipyards there are at present 59 vessels building, which will be completed during 1917. It is believed that the majority of these craft will be sent to the Atlantic for service also.

West Indies Conference.—At Port of Spain, B.W.I., the Associated Chambers of Commerce of the British West Indies discussed England's prohibition of cocoa and rum as imports, and a resolution was passed urging that the prospective customs conference include commercial representatives, and that it also discuss the possibilities of freer trade intercolonially. Other resolutions adopted favored the restriction of business activities of enemy subjects, compulsory registration for aliens, facilitation of exchange of laborers between colonies, development of oil resource metric system, and the purchase of Government supplies by Government agents.

Canadian Mining Institute.—The 19th annual meeting of the Canadian Mining Institute was opened at the Ritz-Carlton Hotel, Montreal, on March 7. The presidential address was delivered by Arthur A. Cole, who reviewed the work of the Institute and stated that abnormally high prices of metals has increased profits and stimulated output so that the year 1916

established a new high level record for production. E. P. Mathewson read an interesting paper on "Industrial Preparedness," while Dr. Frank D. Adams, of McGill University, explained the work of the advisory council for scientific and industrial research. Several other papers were read dealing with minerals and their uses.

Record Prices for Steel.—Steel bars, plates and shapes have never sold higher in the history of the trade than the prices reported from Pittsburg as put into effect recently by the Carnegie Steel Co. Plates were advanced \$15 a ton. Bars and shapes were put up \$7 a ton, making the quotations 3.35 cents a pound for bars and 3.75 cents for shapes. Last Monday wire products were lifted \$4 a ton, the entire development supplying the most spectacular week, so far as prices are concerned, since the current boom got under way. The enormous demand for ship plates from the yards at home and abroad has been the dominant factor in the plate price increase, and structural shapes have also been affected by the expanding shipbuilding industry.

C.P.R. Exhibit of Hydro-Electrics.—To emphasize the economic importance of electric products, and to show their relation to other industries is the object of the C.P.R. Hydro-Electric Exhibit opened on last Monday in the Shaughnessy building, McGill street, Montreal. The exhibit is under the direction of Arthur D. Little, as a part of the Natural Resources Survey. The exhibit has been arranged to interest the layman as well as the specialists, and although it is essentially technical in character, processes are explained so clearly in the accompanying placards, that he who runs may read. An instance of this is the series showing the evolution of the modern incandescent electric lamp. An interesting item shown will be a shell piercer punch with an actual record of having pierced 24,000, 4.5 inch shells.

Will Build Cunarders at Portland.—Several steel freighters of 9,000 tons deadweight capacity will be built for the Cunard Steamship line at Portland, Ore. The contracts here will be divided between the Northwest Steel Co. and the Columbia River Shipbuilding Corporation, with probabilities that increased facilities will be provided. At present the Northwest Steel Co. is the holder of eight contracts for ships of 8,800 tons deadweight, and the Columbia River Shipbuilding Corporation has six of the same size, with at least two Cunarders. Three are well under way at the Northwest plant, and two of those building have been sold to the Cunard line, while at least two others that will be ready for delivery in the fall have been under negotiation, the four having originally been contracted by Lauritz Kloster, of Norway.

Big Increase in Revenue.—Revenues are indicated in the February financial statement issued at Ottawa on March 8. The fiscal year ends this month and a fifty million increase is in prospect. For the eleven months the revenue aggregated \$205,417,039, as against \$154,348,809 for

the corresponding period. February revenue alone was \$17,513,473, an increase of two and three-quarter millions. The total revenue for the fiscal year is estimated at \$225,000,000. Customs and miscellaneous revenue, including the business tax, were the principal sources of increases. Expenditures on current account in the eleven months were \$113,161,357, and on capital \$259,597,008. War outlays in eleven months were \$217,590,670. This is almost double the war expenditure for 1916. It is now about a million a day. The total net debt is now \$765,061,893, which is an increase of nineteen millions in the past month.

Trade With Russia.—Jonas Leid managing director of the Siberian Steamship, Manufacturing and Trading Co., stated recently that there was no reason why Canadian goods could not find a ready market in Siberia, but to capture this trade, he said that it was not sufficient to send out catalogues and invite orders, but agents had to be sent direct to the country to get in touch with the people. Their imports were manufactured goods and their exports were mostly agricultural produce, and he saw no reason why Canada should not be importing Siberian butter in the near future. The railways were blocked on account of the war, and the sea route via the Kara Sea seemed to be the only relief. The vessel which the company sent out last year was sunk by a submarine, but this year they intend starting two specially built steamers, with a tonnage of 6,100 tons, from some American port, and take the passage north of Iceland and north of Norway, then through the Kara Sea to their destination. This route, Mr. Leid explained, was beyond the reach of submarines and was a safe one, as evidenced by the low rate of war insurance on ships taking this route. If they saw that it was possible to take a cargo from Canada they would be prepared to do so, for Siberia was ready to take almost anything in the manufactured.

BOOK REVIEWS

Wire and Sheet Gauge Tables and Metal Calculator, by Thomas Stobbs; 95 pages; 5 x 7½ in. Published by E. & F. N. Spon, Ltd., London, England. Price (3s. 10d.) 95 cents net. This is a new book containing English, metric and foreign wire and sheet gauge tables, with net and gross divisors for finding net and working weights, allowances for mill scrap, etc., with worked examples, weights of all sections of precious and common metals. The book also contains English and metric weight and measure tables with equivalents. The book forms a handy metal calculator and ready reckoner for office and shop use in sheet plate and rod mills, and forges. It is a very useful hand book for merchants and manufacturers, and those connected with the wire, sheet steel and other metal industries. The examples of calculations which precede the tables are worked out in both the English and metric systems, and form a useful feature of the book.

MacKinnon, Holmes & Company, Limited

Design, manufacture and erect all classes of Steel Work.

Specialties :-

- Bridges
- Oil and Water Tanks
- Penstocks
- Coal and Coke Bins
- Smoke Flues & Stacks.

Prompt deliveries assured.

Designs and Estimates from Head Office at

SHERBROOKE, QUE.

Classified Advertising Section begins on page 68. Turn to it.

METAL STAMPINGS

We are manufacturers of stamped parts for other manufacturers.

We do any kind of sheet metal stamping that you require. Our improved presses and plating plant enable us to produce the finest quality of work in a surprisingly short time.

We can finish steel stamping in Nickel, Brass or Copper.

Send us a sample order.

W. H. BANFIELD & SONS

372 Pape Avenue, Toronto, Can.

I BELIEVE

*In Safety First and always.
In providing for the Health of my Fellow Workmen.
In Light and Air and sanitary Working Conditions.
In clean, fresh drinking water for everybody.
In the Safety, Economy and Man-betterment.*

PURO SANITARY DRINKING FOUNTAIN

(MADE IN CANADA)

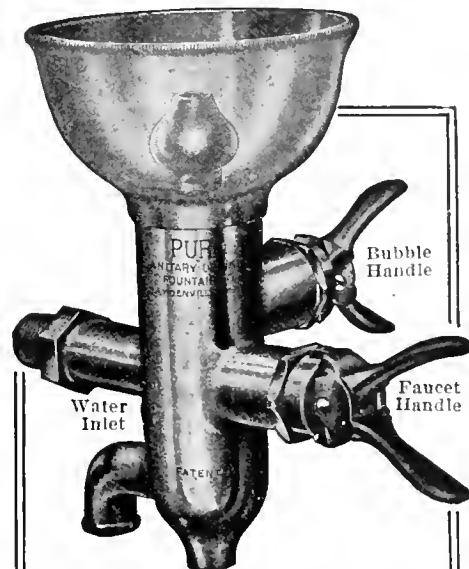

The loss of a man through impure drinking water is a crime that "the front office" must bear.

An ugly statement, isn't it? But true, absolutely.

When a man comes to work in your factory he puts his health in your keeping.

Are you willing to take chances on such a trust?

Impure drinking conditions are responsible for more tragedies than any machine ever built.

Apply the "Safety First" Principles to your water supply; don't deny your men a clean, fresh drink of water.

Conserve their health and they will improve your profits; make yourself as worthy of the name of "employer."

Install the Gold Medal winner Puro in your plant, office and shop alike.

The only Sanitary Drinking Fountain that is safe, sanitary, simple, automatic in control and easily attached.

Let us tell you just what it will cost you to

"PURO - FY"

YOUR WATER SUPPLY

Puro Sanitary Drinking Fountain Company
147 University Ave., Toronto, Canada

THE IRON WORKS LIMITED

Successors to

Owen Sound Iron Works

Owen Sound, Ont.

Engineers

Boiler-makers

Founders

Machinists

Tank Work
Smoke Stacks,
Grey Iron and
Brass Castings,
Special
Machinery
Made to
Order

CATALOGUES

Tap Extractors.—The Walton Company, Hartford, Conn., are distributing two bulletins describing and illustrating a useful device for removing broken taps. The method of using the tool is described and price list included.

The Homestead Valve Mfg. Co., Homestead, Pa., are distributing a bulletin bearing the title "Safety First, then Efficiency, then Economy," having reference to the Homestead line of valves. The "Hovaleo" blow-off valves and "Homestead" quarter-turn valves are also illustrated and described.

The American Pulley Co., Philadelphia, Pa., have issued a booklet entitled "Building 25," descriptive of a new building recently opened at the plant for the convenience of workmen and for safeguarding their health. The booklet contains descriptive matter, and also a series of photographic views showing the principal features of the building, embodying the latest ideas applied to the preservation of health in factories.

Oxy-Acetylene Welding.—The Davis-Bornanville Co. are distributing a bulletin dealing with oxy-acetylene welding and cutting. The bulletin describes the development of the oxy-acetylene process and the progress made by the Davis-Bornanville Co. in connection with this development. The apparatus and its wide range of service are fully described while illustrations show the various types of outfit and torches. Copies of the bulletin may be obtained from the Canadian representatives, the Carter Welding Co., Toronto.

Pipe Machines.—The Williams Tool Co., Erie, Pa., have issued a catalogue illustrating and describing an interesting line of pipe threading and cutting off machines covering a wide range of sizes. A general description for each type covers the principal features and gives the leading dimensions. An interesting feature is a list of repair parts, numbered and illustrated for each type of pipe machine. Each type of machine is shown arranged for belt or motor drive. The concluding pages show special designs of pipe machines direct connected to gasoline and steam engines.

Abrasive Grinding Wheels is the title of an attractive new catalogue No. 6, issued by Abrasive Company, Philadelphia, Pa. The catalogue contains an extensive list of special shaped abrasive grinding wheels for miscellaneous grinding machines. The wheels are classified and illustrated with principal dimensions and price given for each size. Straight, cup and cylinder wheels are also listed, accompanied by rules for calculating list prices. A chapter is devoted to the use and care of wheels, followed by a set of rules for calculating speeds. The principal points involved in the process of manufacture of these wheels, which are made of boro-carbon and electroboron, are briefly described. A table for selection of grain and grade for various classes of work is a useful feature of the catalogue and one of considerable help when ordering. The catalogue contains telegraph and cable codes

and general index. Copies may be obtained from the Canadian distributors, the Canadian B. K. Morton Co., Toronto and Montreal.

PULP AND PAPER INDUSTRIES IN BRITISH COLUMBIA

IF plans in process of being perfected by several companies are successfully carried through, the pulp and paper-making industry in British Columbia will be given a great impetus, and will bring into revenue-producing position some large tracts of timber lands which have been held for some years as pulp concessions. Three large pulp and paper plants have been erected in British Columbia in the past twelve years, but two only have been in operation. One of these, that of the Powell River Co., some hundred miles up the coast of the mainland from Vancouver, has been manufacturing news print and other paper for some years, and the other, that of the B. C. Sulphite Fibre Co., at Mill Creek, Howe Sound, has been making sulphite pulp at its plant for some time since its reorganization.

Great things were hoped for and predicted of the pulp and paper industry some twelve or fourteen years ago, when the then Provincial Government inaugurated a policy of pulp concessions to induce capital to build paper mills in the province. It costs a good deal of money merely to secure and cruise a pulp timber limit. In the time that has intervened since the policy was first established, progress has been somewhat slow in developing the industry, which is capable of becoming such a factor in commerce and production from the timber resources of British Columbia.

To-day, through altered trade conditions brought about by the war, and accentuated by its continuance, more attention than ever before is being given to development. There will be activity on all the pulp concessions which have been granted, and which have been held ever since the days when the plan was devised. Two large plants which have lain idle almost since their construction are being placed in order for active operations. On the fourth concession, that at Quatsino Sound, on the north end of Vancouver Island, where no mill has yet been erected, the interests controlling it are said to be making plans for early construction.

Trade Inquiries

THE Department of Trade and Commerce, Ottawa, has received the following enquiries:—

558. Agency.—A Durban firm specializing in machinery and mechanical appliances is prepared to take up Canadian agencies on lathes, drilling machines machine tools.

569. Boilers.—Canadian manufacturers of hot-water boilers having a heating capacity of not less than 800 feet are asked to communicate with a Newfoundland inquirer.

"Barnes-made" SPRINGS



are the result of over sixty years' experience in spring making, combined with unsurpassed equipment and the workmanship of men who have been with us, ten, twenty and in some cases thirty years.

Write for booklet No. 7-T.

Established 1857.

THE WALLACE BARNES COMPANY

218 South St., Bristol, Ct., U.S.A.

Mfrs of "Barnes-made" Products
Springs, Screw Machine Products, Cold Rolled Steel and Wire

"HAWK" D CHROME VANADIUM STEEL



Will
Give You
Exceptional

Shell Forging Production

WITHOUT AN EQUAL FOR
BOTH FIRST AND
SECOND OPERATION
PUNCHES.

Comes to you heat-treated
and ready for use.

It does not stick to the
work.

There are many cases where
each punch has turned out
over 2,000 shells....

It means more shells, per
machine per day.

STEEL OF EVERY
DESCRIPTION.

Hawkrige Brothers
Company

303 Congress St., BOSTON, MASS.
U. S. A.

AMERICAN MACHINERY EXPORTS

THE value of the exports of machinery from the United States in the seven months ended January 31, this year, was \$92,518,708, as compared with \$44,993,573 in the corresponding period of 1914-15. The largest exports in the seven months ended January 31, this year, were metal-working machinery, which represented a value of \$25,196,917. The value of certain other exports was:—Gasoline engines, \$4,423,507; steam-engines, \$11,151,462; parts of engines, \$3,714,109; milling machinery, \$1,584,442; paper-mill machinery, \$3,766,695; sewing machines, \$3,092,705; sugar machinery, \$4,902,099; and typewriting machines, \$4,654,166. The value of the machinery exported from the United States last year was \$134,128,862, and that of machine tools, \$41,037,779. The American International Corporation has bought up the Allied Machinery Company of America, and proposes to extend the business of that undertaking, which aims at assisting American manufacturers of machine tools to place their products in foreign countries. The company has shown rooms in Paris, Petrograd, Zurich, and Turin.



Empire Resources Development.—A great private organization, aiming "to promote the development of the Empire resources in order to assist in the payment of the war debt," has been launched under a committee styled the Empire Resources Development Committee. The chairman of the committee is Sir Leander Starr Jameson, president of the British South African Co., and its membership includes Earl Grey, Lords Selborne, Desborough, Dunraven, Islington and Plymouth; Alfred Bigland, L. W. Evans and A. H. Paget, members of the House of Commons, and Rudyard Kipling. The purposes of the committee are outlined as "conservation for the benefit of the Empire, of such natural resources as are or may come under the ownership or control of the Imperial, Dominion and Indian Governments; the development of selected resources of the Empire under such conditions as will give the State an adequate share; and conserving and developing the resources of the Empire so the Imperial effort may concentrate on assets ripe for development for the common good of the Empire."



You tell me that there are many unpleasant things troubling you in the place in which you work. If you can answer without betraying a secret,—would you mind telling me if you ever knew of velvet being used successfully as a substitute for sandpaper? The unpleasant, the hard, the trying, the temper-testing things are the sandpaper aids that smooth you off—that train you—that fit you to shoulder bigger responsibilities and to resist more trying troubles later. So be very thankful for the sandpaper.



Steel Shell Forgings or Billets of any size or weight will move any distance or about curves upon our specially constructed Gravity Carriers and Incline or Horizontal power devices. No labor required.

Canadian Mathews Gravity [Carrier Co., Toronto, Ont.

Nothing Wonderful

—but not bad for two insertions

"—to the best of our knowledge we disposed of all our motors through the advertisement in Canadian Machinery."

We can do the same for you.

CANADIAN MACHINERY

(Classified Advertising Section)

143 University Ave. Toronto, Ontario

OVENS

Enameling and Varnishing Ovens heated by Gas, Electricity, Steam or Coal.
Write for Booklet.

Brantford Oven & Rack Co., Ltd.
Brantford, Canada.

MORTON MANUFACTURING CO.

PORTABLE PLANERS
DRAW CUT SHAPERS
SPECIAL DRAW CUT R R SHAPERS
FINISHED MACHINE KEYS
STATIONARY & PORTABLE KEY WAY CUTTERS
SPECIAL LOCOMOTIVE CYLINDER PLANERS

OFFICE AND WORKS: MUSKEGON HEIGHTS U.S.A.

ECONOMY No. 40 HEAVY DUTY, the EFFICIENT SHELL SAW

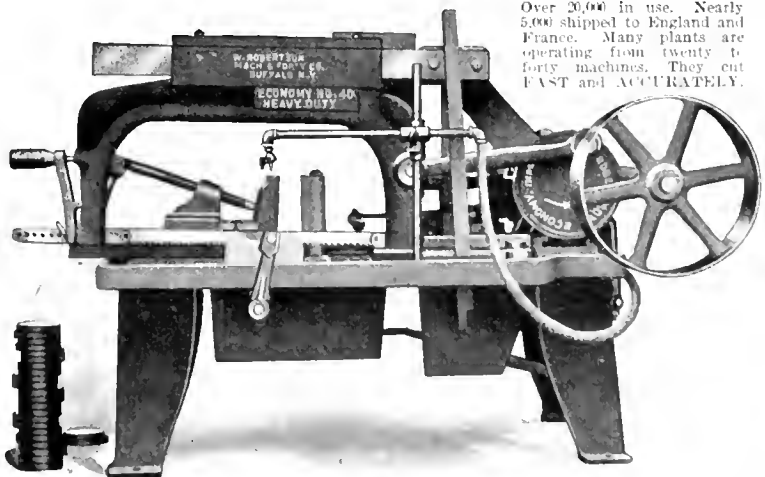

Over 20,000 in use. Nearly 5,000 shipped to England and France. Many plants are operating from twenty to forty machines. They cut FAST and ACCURATELY.

Draw Cut—Oil Compression Lift, relieving the blade on the return stroke. Frame cannot fall and break blades. Quick Acting Vise—Cut Gears—Friction Drive—Automatic Stop. Capacity 8 x 8". Takes blades from 10 to 17". This tool will give greater production at less cost than any tool in your plant. Economy Saws are built in sizes up to 8 x 18". PROMPT DELIVERIES.

W. Robertson Machine & Foundry Company, Buffalo, N.Y., U.S.A.

Classified Advertising Section

Rates (payable in advance): Two cents per word first insertion; one cent per word subsequent insertions. Count five words when box number is required. Each figure counts as one word. Minimum order \$1.00. Display rates on application.

FOR SALE

FOR SALE—ENGINE LATHE 30" SWING, 8 ft. bed. Putnam make. good strong tool. cheap. Box 269, Canadian Machinery. (c8m)

FOR SALE—LOT OF WOODWORKING machinery—shafting, pulleys, hangers, belting, etc. Cheap. Box 270, Canadian Machinery. (c8m)

FOR SALE—PIG LEAD AND LEAD IN 10-lb. bars for immediate shipment. We can sell this at considerably below market quotation. Geo. E. Jobborn, 56 Guise Street, Hamilton. (c9m)

GAP LATHE, 28 x 42 x 16 FT. BED, FOR sale, cheap; also emery wheel stand, power hack saw. Guarantee Motor Co., Hamilton, Ont. (tf)

FOR SALE, AT A REASONABLE PRICE—three 3 $\frac{3}{4}$ " and two 2 $\frac{3}{4}$ " style C geometric die heads, with 1 $\frac{1}{4}$ " shank. H. Mueller Mfg. Co., Ltd., Sarnia, Ont. (c9m)

FOR SALE—ONE 450 H.P. THOMPSON & Williams condensing engine. Will sell cheap. Engine is in first-class repair and will give every satisfaction. Apply J. A. Marven, Limited, Moncton, N.B. (tfm)

1—2-SPINDLE SHAPER, WOOD TOP, JOHN Ballantyne, Preston, make, used two months. 1 Dynamo, 45 lights, Toronto and Hamilton Electric Co. make. Used five months. Good as new. Box 195, Jordan, Ont. (R.T.F.)

TRUCKS—A NUMBER OF SECOND-HAND trucks, manufactured by the Watson Manufacturing Company, Limited, Ayr, and Wm. and J. G. Greer, Toronto. Approximate size 26" x 18". Price \$7.50 each f.o.b. Toronto. In good shape. The A. B. Ormsby Company, Limited, Toronto. (c11m)

FOR SALE—88 H.P. CROSSLEY GAS EN- gine. Will develop 115 H.P. on natural gas; in perfect condition. Used only 18 months. Speed 200 R.P.M. This is suction gas plant with producers, compressor and tanks, but is ideal for natural gas. Will sell cheap. P. L. Robertson Co., Milton, Ont. (c11m)

1 ONLY—10" WESTINGHOUSE LOCOMO- tive air compressor, first-class condition, all complete, ready for installation. 1 only, 6 x 6 Imperial type Canadian Ingersoll-Rand Company air compressor, in good condition, complete, ready for installation. H. Mueller Mfg. Co., Ltd., Sarnia, Ont. (c8m)

ONE LATHE 16" x 4 $\frac{1}{2}$ " back geared. Built by P. P. Silk Machine & Tool Co., Cincinnati, Ohio. One lathe 18" x 3", hack geared. Built by the Bradford Mill Co., Cincinnati, Ohio. Four Murehey Collapsible Dies. Capacity 1 $\frac{1}{2}$ " to 2 $\frac{1}{2}$ ". Box 272, Canadian Machinery. (c11m)

FOR SALE—2 KENNEDY CUTTING-OFF machines, for cutting off both ends of 4.5 H.E. forgings; in good condition; price \$750 each. 1 18-pdr. Holden-Morgan thread miller for threading base end of high explosive shells; price \$300. 1 18-pdr. H.E. marking machine; price \$50. Apply to Alton Foundry Co., Ltd., Alton, Ontario. (c13m)

3—20 H.P., 60 CYCLE, 440 VOLT, 3 PHASE, 3 900 R.P.M. induction motors with starting compensators and adjustable sliding bases; Canadian General Electric Company's latest type, practically new. \$350.00. 2—15 H.P., same as above, \$315.00; 1—35 H.P., same as above, \$440.00; 2—5 H.P., 1200 R.P.M., complete, with pulley 5 $\frac{1}{2}$ " diameter, 4 $\frac{1}{2}$ " face, otherwise the same as above motors, \$95.00; 2—2 H.P. pulley, 4 $\frac{1}{2}$ " diameter, 3 $\frac{1}{2}$ " face, \$80; 1—1 H.P. pulley, 4 in. diameter, 2 $\frac{1}{2}$ " face, \$65. Prices f.o.b. Sarnia. Perfection Stove Co., Ltd., Sarnia, Ont. (c11m)

WANTED

WANTED—MOTORS 10 TO 50 HORSE- power, 25 cycle, 550 volts, alternating current. Quote price and delivery. Canadian Fairbanks-Morse Co., 1379 Bloor Street, Toronto. (c11m)

SPECIAL MACHINERY

MANUFACTURERS—WE CAN UNDER- take work to any specification—mation production equipment or otherwise. Write W. H. Sumbing Machinery Co., 7 St. Mary St., Toronto.

Why do these small ads bring results?

You'd think these small ads. would never be noticed—you'd think a busy man would never take time to read this mass of small type.

That would probably be the case if the ads were not of vital interest to practically all our readers, and if they did not realize this.

But the men who read this page every week—the Managers, Works Managers, Machine Shop Owners, Superintendents, Master Mechanics, Foremen, Tool-makers, etc.—are alive to the fact that these small ads mean dollars to them.

That is why your ad here will bring results.

Canadian Machinery
Classified Advertising Section
143 University Ave., Toronto, Ont.

SITUATIONS WANTED

MAN ABOUT 30, WITH ENGINEERING and commercial training, experienced in mine and smelter requirements, including structural and cast steel work. A man with office experience and capable of soliciting business preferable. Box 283, Canadian Machinery. (c13m)

MECHANICAL ENGINEER WITH LONG experience designing and estimating on machine tools, special shell machinery, tools, jigs and fixtures, desires responsible position with well established company. Best of references given from well-known companies. Box 284, Canadian Machinery. (c12m)

SUPERINTENDENT WITH NINETEEN years' mechanical experience in manufacturing and repairing of machinery and structural steel, both shop and erection, desires change of position. Experienced in machining 18-Pr. and 4.5" high explosive shells. Aggressive character, good organizer, best of references. Box 282, Canadian Machinery. (c12m)

MACHINE SHOP FOREMAN, EXPERT all round machinist with technical training desires to connect with aggressive engineering firm. Twenty years' practical shop experience—four years in stationary and marine engine works, 4 years in steel plant, 2 years' tool room experience, 10 years in locomotive shop. Box 279 Canadian Machinery. (c11m)

SUPERINTENDENT OR WORKS MANAGER of large metal working plant desires change. Broad gauge man of modern methods and a producer of results. Over 20 years' experience at handling large forces of workmen in manufacture of high quality and interchangeable goods of brass, iron and steel, special tools, dies, machinery, etc. Includes brass works, machine shop, punching and stamping and fine brass work, taking entire control of plant. English-American descent. Box 280, Canadian Machinery. (c11m)

SITUATIONS VACANT

BRASS MACHINE FOREMAN WANTED— man capable of handling small brass shop on munitions. None but a hustler need apply. Box 277, Canadian Machinery. (c11m)

DIE MAKERS—SERVICES OF TWO FIRST- class die makers to work on small dies for parts of electrical wiring devices. Apply Toronto Electrical Supply Work, King street Subway. (c10m)

WANTED—MACHINERY SALESMAN FOR Michigan territory. Must have experience with both new and second-hand machinery, and capable of getting results. In applying, state experience and salary expected. Box 276, Canadian Machinery. (c11m)

A GOOD SALES ENGINEER TO OPEN office to sell Moline Heat in Canadian territory. Must be a good salesman, having had a general heating and ventilating experience. Must give good references. We have a fine proposition for the right man. Address, Moline Heat, Moline, Ill. (c11m)

FOREMAN TOOL MAKER WANTED ON electrical sockets and appliance work. Preference will be given to man who has had experience with automatic feeding of punch presses for blanking and forming operations. It is essentially necessary that the applicant has had experience in brass drawing dies. Only first-class men need apply. State experience and wages. Apply Box 278, Canadian Machinery. (c9m)

CANADIAN MACHINERY

AND MANUFACTURING NEWS

A weekly newspaper devoted to the machinery and manufacturing interests.

Vol. XVII.

TORONTO, MARCH 22, 1917

No. 12

EDITORIAL CONTENTS

8-Inch H.E. Shell Production in a Machine Tool Plant	279-284
General	281
Future of Canadian Iron and Steel....Electrical Processes in Metallurgy.	
Production Methods and Devices	285-288
Saving Money on Planer Knives A Three Collar Sensitive Drill Conveyor Equipment in a Cartridge Case Plant....Globe Valve Experiences.	
General	288
Industrial Development of Eastern Canada.	
Spokes in Industry's Wheel	289
Percy Oscar Gordon Janes.	
Editorial Correspondence	290-292
Machinists' Instruction Course—XVI....Savings Made Possible by Ball-bearing Hang- ers....Line Shaft Troubles.	
Progress in New Equipment	293-295
Universal Gauge Grinder....Shrapnel Socket Machine 20-inch Crank Shaper Relieving Attachment for Engine Lathe.	
General	295
Canadian Fairbanks-Morse Pension Fund.	
Editorial	296
Canadian Steel Industry Outlook....Canada's Director of Shipbuilding Training Schools for Apprentices.	
Industrial Notabilities	297
Charles Frederick Wheaton.	
Selected Market Quotations	298-299
The General Market Condition and Tendency	299-303
Summary....Montreal Letter....Toronto Letter....Sydney Letter.... Canadian Trade Increases in Volume....Financing Sales Abroad by Drafts Canadian Fairbanks Morse Pension Fund.	
Industrial and Construction News	304

THE MACLEAN PUBLISHING COMPANY, LIMITED

JOHN BAYNE MACLEAN, Pres. H. T. HUNTER, Vice-pres. H. V. TYRRELL, Gen. Man.

Publishers of Hardware and Metal, The Financial Post, MacLean's Magazine, Farmer's Magazine, Canadian Grocer, Dry Goods Review, Men's Wear Review, Printer and Publisher, Bookseller and Stationer, Canadian Machinery and Manufacturing News, The Power House, The Sanitary Engineer, Canadian Foundryman, Marine Engineering of Canada.

Cable Address: Macpulco, Toronto; Atabek, London, Eng.

ESTABLISHED 1887.

CANADIAN MACHINERY

AND MANUFACTURING NEWS

PETER BAIN, M.E., Editor. B. G. NEWTON, Manager.
Associate Editors: A. G. WEBSTER, J. M. WILSON, J. H. RODGERS.

CHIEF OFFICES:

CANADA—Montreal, 501-502 Eastern Townships Building; Toronto, 143-153 University Ave., Telephone Main 7324; Winnipeg, 22 Royal Bank Building, Telephone Garry 2313.

GREAT BRITAIN—LONDON, The MacLean Company of Great Britain, Limited, 88 Fleet Street, E.C., E. J. Dodd, Director. Telephone Central 12900. Cable Address: Atabek, London, England.

UNITED STATES—New York, R. B. Huestis, 115 Broadway, N.Y., Telephone Rector 8944; Boston, C. L. Morton, Room, 733, Old South Building, Telephone Main 1204. A. H. Byrne, 1101 5-6-7 Fort Dearborn Bldg., 195 W. Monroe St., Chicago, Telephone Randolph 3234.

SUBSCRIPTION PRICE—Canada, Great Britain, South Africa and the West Indies, \$3.00 a year; United States, \$3.50 a year; other countries, \$4.00 a year; Single Copies, 15 cents. Invariably in advance.

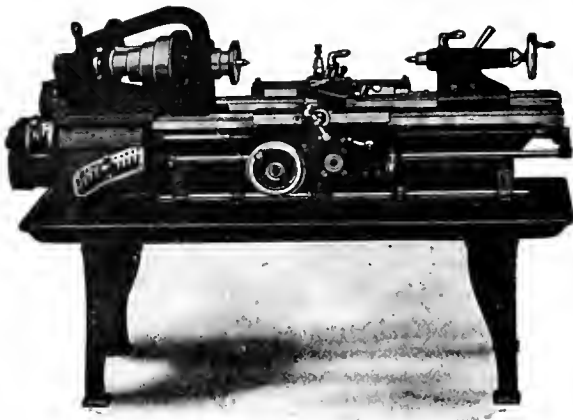

The "HENDEY" Lathe

The Service

Capacity and Convenience

of a Hendey Lathe will prove of vital importance to your tool room.

The "Hendey" is accurate in the highest degree and suited for the efficient use of watch tool chucks, stop chucks, relieving attachments, etc.

It has the best spindle construction in its taper journals, with annular bearings and automatic oiling rings, which make for accuracy of alignment.

It has **automatic stop** for carriage working in either direction. Has reverse for carriage, controlled from apron.

Wide range of threads and feeds through mounted gearing, with ability to make gear changes for additional threads and feeds without limit.

A card will get you full particulars. Why not mail it now?

THE HENDEY MACHINE COMPANY

TORRINGTON, CONN., U.S.A.

Canadian Agents: A. R. Williams Machinery Co., Toronto, Ont.; A. R. Williams Machinery Co., 260 Princess St., Winnipeg; A. R. Williams Machinery Co., Vancouver; A. R. Williams Machinery Co., St. John, N.B.; Williams & Wilson, Montreal.

INDEX TO ADVERTISERS

A	Alkenthal Hdw. Co. 61	De Moro Smelting & Refining Co. ... 4	Joyce, Geo. A., Co. 97	Draft & Whitney Inside front cover
	Albany Pump Co. 62	De Mooy Mach. Co. 105	Jersey City Mach. Co. 94	Pringle, R. E. T., Ltd. 51
	American Pulley Co. 82	Dept. of Finance 109	K	Puro Sanitary Drink'g Fountain Co. 64
	Armstrong Bros. Tool Co. 92	Dodge Mfg. Co. 81	Kasent, Limited 9	R
	Armstrong, Whitworth of Canada ... 7	Dominion Forge & Stamping Co. ... 78	Kemp Smith Mfg. Co. 23	Racine Tool & Machine Co. 79
	Atkins, Wm., & Co., Ltd. 10	Dominion Iron & Wrecking Co. ... 30	Kennedy, Wm. & Sons 50	Riverside Machy. Depot 67
	Atlas Crucible Steel Co. 8	Dominion Machinery Co. 70	L	Rivett, Lathe & Grinder Co. 110
	Aurora Tool Works 107	Dominion Steel Foundry Co. 91	L. Air Liquid Society 30	Robertson Mach. & Pdy. Co. 62
B		E	Lambis Machine Co. 92	Rockford Drilling Machine Co. ... 107
	B. A. B. Model Mfg. Co. 75	Eastern Mach. Screw Corp 86	Latiche Elect. Steel Co. 65	Roeelson Machine & Tool Co. ... 30
	Babcock & Sons 62	Elmes, Chas. F. 103	M	Roper & Co., C. F. 25
	Baird Machine Co. 92	Eric Foundry Co. 103	Macnab, John, Machy. Co. 18	S
	Banfield, E. J. 62	F	Marion & Marion 62	Scott Machy. Co., G. H. 76
	Banfield, W. H., & Sons 63	Fetherstonhaugh & Co. 62	Manufacturers Equipment Co. ... 86	Shuster Co., F. R. 91
	Barnes, W. P., & John 107	Fitzgerald, W. H. J. 68	Marsh & Henthorn, Ltd. 28	Simmons Mach. Co., Inc. 74
	Barnes, Wallace, Co. 60	Ford-Smith Mach. Co. 23	Matthews, Jas. H., & Co., Inc. ... 91	Skinner Chuck Co. 62
	Bertram, John, & Sons Co., Ltd. ... 1	Foss & Hill Machy. Co. 50	McCabe, J. J. 18	Slocum, Avram & Slocum 99
	Brantford Oven & Rack Co. 63	G	McCoy-Branitt Machy. Co. 68	Standard Alloys Co. 11
	Brantford Mach. Tool Wks. 5	Francis & Co. Inside back cover	McDougall Co., H. Inside back cover	Starret Co., L. S. 19
	Bristol Company 91	G	McLaren, J. C., Helting Co. 91	St. Clair Bros. 68
	Brown, Boggs 16	Galt Mach. Screw Co. 76	Mechanical Engineering Co. ... 25	Steel Co., of Canada 23
	Brown Engineering Corp. 75	Gardner Machine Co. 63	Metalwood Mfg. Co. 28	Steeple, John, Co. 71
	Brown & Sharpe 97	Garlock-Walker Machy. Co. 69	Metals Coating Co. 19	Stocker-Rumley-Wachs Co. 71
	Brownell Machy. Co. 74	Garvin Machine Co. 52	Millers Falls Co. 78	Stow Mfg. Co. 101
	Brown's Copper & Brass Rolling Mills 57	Geometric Tool Co. 84	Miller, Smythe Elect. Co. 66	Swedish Steel & Importing Co. ... 8
	Bulden, Hanbury A. 62	Gibb Instrument Co. 84	Milholand Co., W. K. 16	T
	Butterfield & Co., Inc. 89	Gilbert & Barker Mfg. Co. 76	Milton Mfg. Co. 72	T. C. M. Mfg. Co. 24
C		Globe Machine & Stamping Co. ... 75	Mooley & Hawley 198	Tabor Mfg. Co. 95
	Can. Bend Hauger & Comding Co. ... 83	Globe Machine & Stamping Co. ... 97	Montreal General Tool Co. 14	Taylor Instrument Co. 84
	Canada Machinery Corporation 103	Hodley & Edmund 94	Moylem Machy. Ex. 67	Taylor Instrument Co. 84
	Canada Metal Co. Outside back cover	Grant Gear Works, Inc. 94	Monarch Brass Mfg. Co. 77	Thwing Instrument Co. 84
	Canada Wire & Iron Goods Co. 91	Grant Mfg. & Machine Co. 103	Montreal Machy. & Supplies 29	Toronto Iron Works 91
	Can. B. K. Morton Co. 13	Greenfield Machine Co. 92	Modern Tool Co. 99	U
	Can. Blower & Forge Co. 52	H	Morton Mfg. Co. 66	United Tool Chest Works 95
	Can. Fairbanks-Morse Co. 78	Hamilton Gear & Machine Co. 76	Mouchey Machine & Tool Co. 87	United States Electrical Tool Co. ... 95
	Can. Bessemer-Stephan Mfg. Co. ... 72	Hamilton Machine Tool Works 21	N	V
	Can. Drawn Steel 82	Hanan & Co., M. A. 8	National Machine Tool Co. 93	Vanadium Alloys Steel 6
	Can. Economic Lubricant Co. 97	Hawkins Bros. 65	New Britain Mach. Co. 65	Vulcan Crucible Steel Co. 9
	Can. Inspection & Testing Laboratories, Ltd. 91	Hendey Machine Co. 112	New York Machinery Exchange ... 70	W
	Can. Steel Foundries, Ltd. 7	Himoff Mach. Co. 62	Nicholson File Co. 82	Walls Tool & Supply Co. 161
	Can. Welding Works 24	Hobbs, John T. 15	Niles-Bement-Pond, Inside front cover	Walton Co. 86
	Carlyse Johnson Mach. Co. 85	Holz, Herman A. 84	Noble & Westbrook Co. 91	Walcott Lathe Co. 25
	Charman Double Ball Bearing Co. 83	Hoyt Metal Co. 9.4	Northern Brass Works 91	Welbome & Co. 64
	Chenierati Pulley Machy. Co. 195	Hungford Brass & Copper Co. ... 26	Norton, A. O. 94	Wells Bros. Co., of Canada 28
	Corbet Foundry & Mach. Co. 14	Hurland Rogers Machinery Co. ... 94	Norton Co. 31	West Tire Setter 80
	Cook, Asa S. 93	Hvb Engineering Works 66	Nova Scotia Steel & Coal Co. 6	Whipple & Choate 35
	Cushman Machy. Co., C. W. 68	I	Oven Equipment & Mfg. Co. 24	Whiting Foundry Equipment Co. ... 35
	Cushman Chuck Co. 93	Ideal Tool & Vlg. Co. 35	P	Williams, A. R., Machinery Co., 7 & 8
D		Independent Pneumatic Tool Co. ... 101	Parmenter & Bulloch Co. 94	Williams, J. H., & Co. 26
	Dayport Loco. Works 12	Iron Works, The 63	Perini, Wm. R. 19	Williams Tools Co. 79
	Davis Remonville Co. 92	J	Peerless Machine Co. 79	Williams & Wilson 79
	Day, W. F. Machine Tool Co. 71	Jacobs Mfg. Co. 88	Petrie, of Montreal, Ltd., H. W. ... 17	Windsor Mach. & Tool Works 11
		Jencks Mach. Co. 9	Petrie, H. W., Ltd. 67	Winnipeg Gear & Engineering Co. ... 70
		Johnson Mach. Co., Carleton 5	Positive Clutch & Pulley Works ... 92	Z
				Zenith Coal & Steel Products Co. ... 92

8 Inch H. E. Shell Production in a Machine Tool Plant

Staff Article

The plant here described has earned the distinction of successfully undertaking the production of 18-pdr. shrapnel, 18-pdr. and 8-in. high explosive shells; the two former of which have already been featured in these columns. It seems, therefore, appropriate that the departmental layout and equipment for machining big shell should also be given a place.

THE production of 8 in. howitzer shells on a quantity basis has been in progress in Canadian factories for nearly a year, and the number of plants now producing possess numerous individual features of interest to machinists. The variation of method encountered in the making of 8 in. shells is greater than that met with in shrapnel, in proportion to the number of firms engaged; not only that, but the differences in 8 in. shell work

tool-builders' viewpoint, rather than that of emergency production with extemporized equipment.

Uniformity of Machine Groups

Due to a fortunate combination of circumstances, it was possible to secure the machines in groups, thus rendering possible the duplication of tool equipment for all the machines engaged on a particular operation; it further prevented any drop in output when an

manner, unhampered by lack of space, transmission equipment or handling facilities.

The plan view of the shop, Fig. 1, shows the path of the work which is purely progressive. Starting from the point where the forgings are discharged from the freight car, the work passes up No. 1 bay and half-way down No. 2 bay in parallel streams, thence down one side of No. 2 bay and up the other,

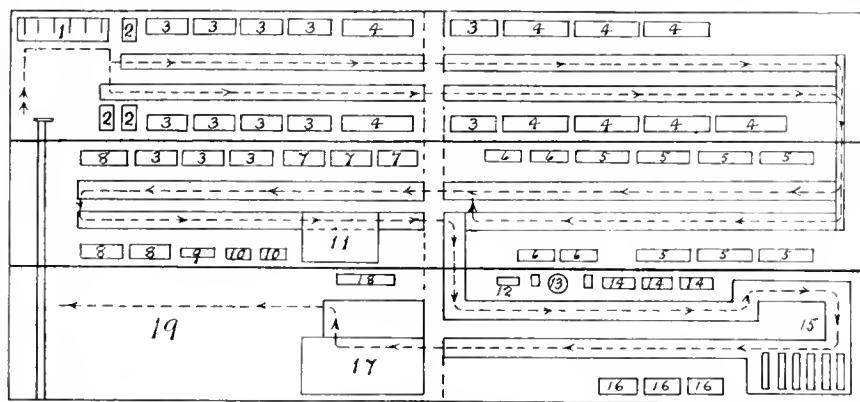

FIG. 1. LAYOUT OF SHOP ARRANGEMENT SHOWING PATH OF WORK DURING MANUFACTURE.

- 1—Nose drilling and facing. 2—Cutting-off base. 3—Rough turning body. 4 Boring interior complete. 5—Finish turning complete. 6—Machine nose hole complete. 7 Face and recess base. 8—Machine groove complete. 9—Mill nose thread. 10—Mill base thread. 11—Inspection. 12—Adapter driving. 13—Band pressing. 14—Rivet and face adapter. 15 Varnish and bake. 16—Turn copper band. 17 Final inspection. 18 Mark on base. 19 Shipping department.

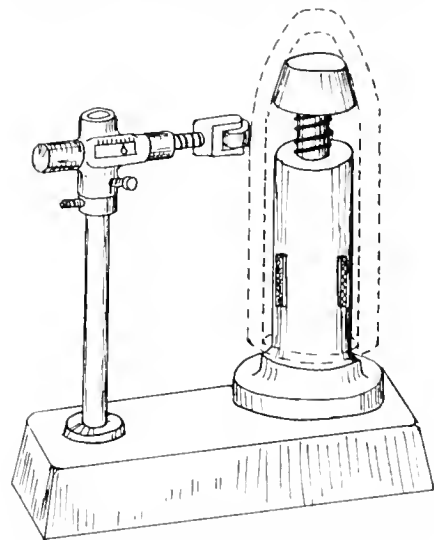

FIG. 2. GAUGING FIXTURE FOR CHECKING CONCENTRICITY OF FORGING

are more basic in their origin and greater in their influence on the work as a whole, than the numerous variations of procedure which were evolved in the manufacture of shrapnel.

Previous articles on 8 in. shell work which have appeared in these columns have dealt with plants which handled the problem in one of two methods, i.e., a judicious combination of special and standard machine tools with such variations in tool equipment and handling methods as were due to the individual tool designers, or, a full equipment of specially built machine tools, each of which forms a unit of an inflexible system, the adoption of which allows the free use of unskilled labor with a maximum output, subject, however, to more frequent inspection, etc. The plant described herewith belongs to the first class of plant mentioned, but possesses a unique individuality in regard to one or two features which will be referred to in due course. The sequence of operations, degree of accuracy, and types of machines employed are, however, characteristic of a plant which has been accustomed to heavy machine tool work of the highest class and which consequently approached the work from the

operator for any reason had to change to another machine. The existence of a three-bay shop of very modern design enabled the installation of the machines to be accomplished in a most efficient

crossing into No. 3 bay half-way up, thence up one side and down the other to the inspection, marking, and shipping which occupy the full width of the remainder of No. 3 bay. Each bay is

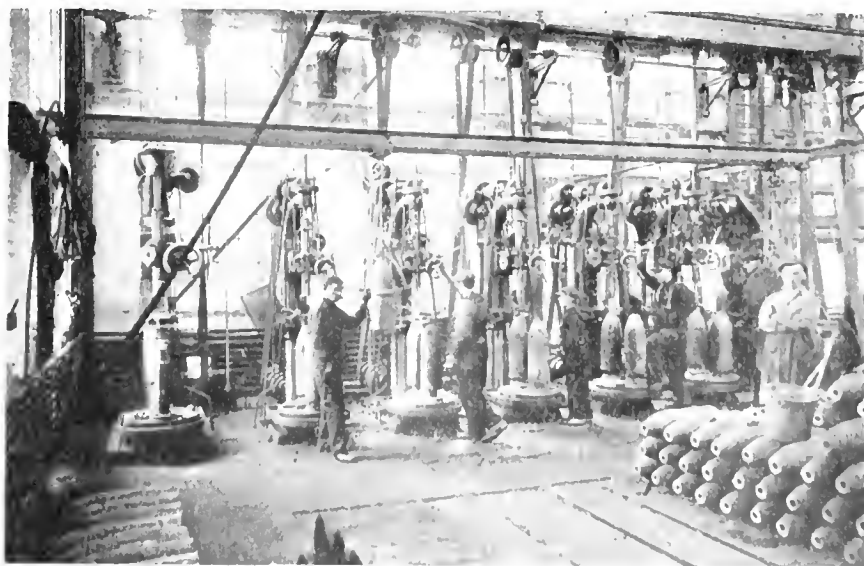

FIG. 3. BATTERY OF DRILL PRESSES WITH REVOLVING TABLE EQUIPMENT DRILLING AND FACING HOLE IN NOSE.

served by a 5-ton Niles crane, which was part of the original equipment, and was of great service in laying out the present installation.

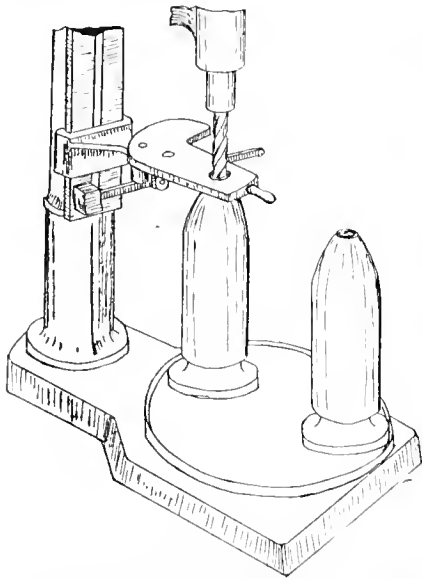

FIG. 4. SKETCH OF SWIVELING JIG USED FOR STARTING DRILL IN NOSE.

The conveying of the shells is entirely along raised tracks on which they roll; each machine being equipped with half-ton quick-acting chain blocks of the Herbert Morris type, slinging belts, hooks and automatic clamps being used for gripping the shell as required.

Forgings Tested on Receipt

Immediately on receipt, the forgings are tested for concentricity on an indicating fixture, Fig. 2, with a pointer and scale as shown. Should there be sufficient thickness in the walls, it is possible to divide the eccentricity between the boring and the turning, thus necessitating special locating of the hole in the nose. All normal shells, however, are immediately drilled and faced in a battery of six Bertram vertical drilling machines shown in Fig. 3. Each machine is an independent unit with revolving work table having two centering arbors for supporting the

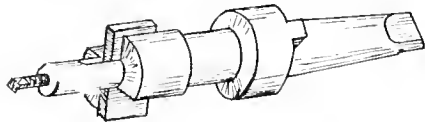

FIG. 5. FACING CUTTER AND BAR FOR FACING NOSE.

forgings. A trolley track extends along the row, immediately above the idle arbors and the forging is hoisted up to the proper height by a pneumatic hoist at the extreme left where the chain block is attached and the forging transferred to the particular spindle desired.

No marking-off is resorted to. A swivelling jig plate is mounted on the drill column, Fig. 4, both forging being drilled first and then faced by a double cutter bar, Fig. 5, of simple and efficient design. It is provided with driving keys on a collar which engage in a slot in the drill spindle, as the heavy duty was too severe for any ordinary drill tang with flat ends.

The faced nose is now used to locate forging in the chucks of three Root & Van Dervoort cutting-off machines. Two cutting tools are employed, and are off-

automatic expanding driver of the eccentric groove type. The turned shell is then lifted by a flat belt sling and chain block and deposited in the open-

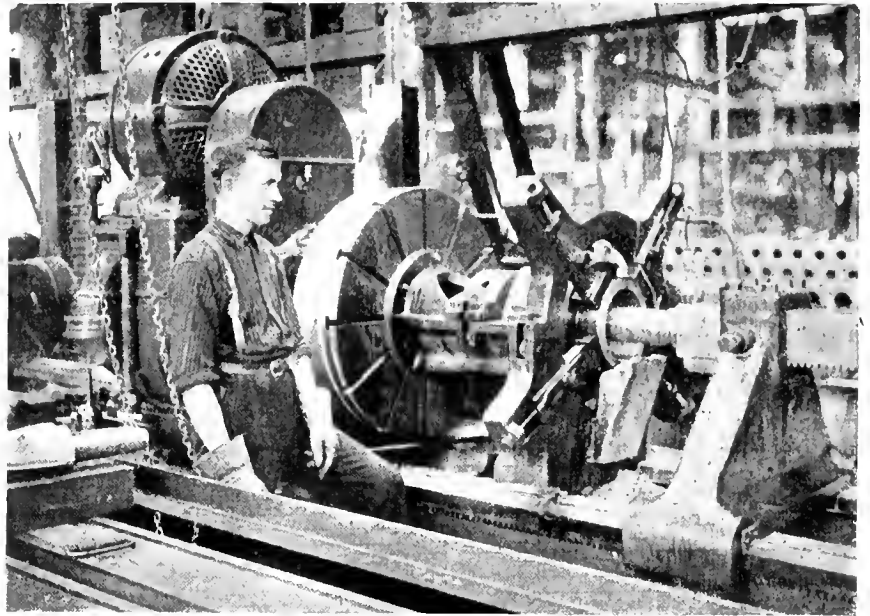

FIG. 6. MACHINING INTERIOR COMPLETE IN SPECIAL BORING LATHIE.

set with respect to each other so that ample clearance is obtained to prevent undue choking and heating of the tools as the depth of cut increases. As indicated in Fig. 1, these machines are at the beginning of the tracks, two machines being on one side to supply the greater number of rough-turning lathes adjacent thereto.

Roughing and Boring

Thirteen 24-in. Bridgeford lathes are

sided chuck of one of the boring lathes, Fig. 6. It is clamped in position by two hinged straps. The machines used for this work are built by Niles-Bement-Pond, and are of their standard shell boring design with individual motor drive and square boring bar fed by rack and pinion in tailstock and supported by sliding brace gibbed to ways of bed.

The regular run of forgings are finished with two cutter heads of the acorn

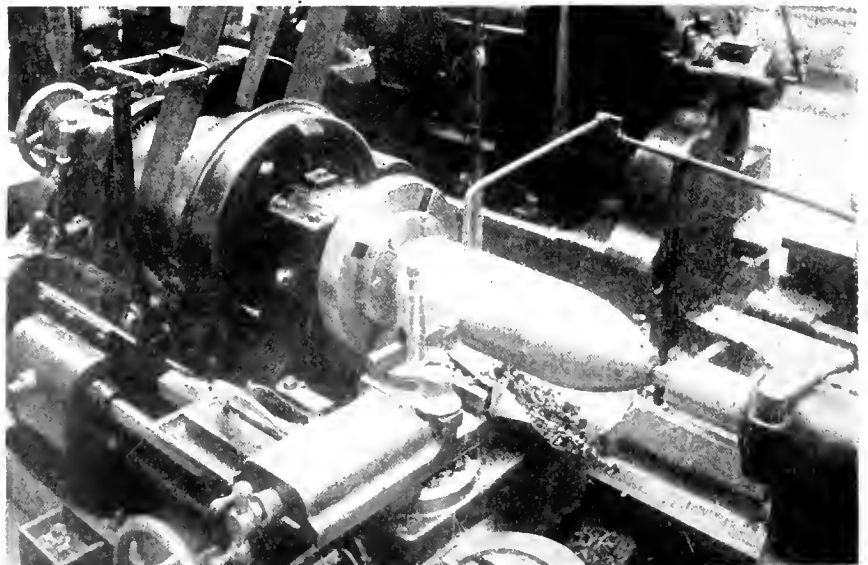

FIG. 7. FINISH TURNING SHELL BODY TO GAUGE.

engaged rough turning. These lathes are equipped with two carriages, for parallel and radial travel, link control of the usual type imparting the curve to the nose. During this operation, the shell is supported by a pipe centre in the nose, and is driven by a three-jaw

type. The first or rougher is three-bladed with notched edges, and the second is double-bladed with smooth edges. Occasionally a forging with bore rather much off centre necessitates the use of a preliminary rougher which has three blades with notches of a special

design which enable the uneven cut to be handled satisfactorily. The trued bore is then completed with the two regular cutters. All of these cutters are made with taper shanks, and are ground to form in a special grinding machine which holds them by the shank. All curves are obtained by swivelling the

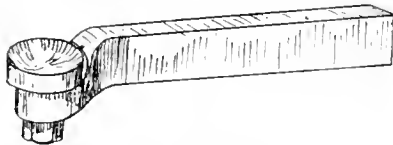

FIG. 8. CUP TOOL USED IN LATHE SHOWN IN FIG. 7.

chuck around points, stops and adjustments enabling the desired outline of the blades to be quickly and accurately attained.

Finish Turning

The shells have now reached the end of No. 1 bay and are transferred by a roller conveyor track to No. 2 bay where finish turning is done. In this, and in the previous operation of boring, no limit is allowed on the finished diameters. The shell is carried on an expanding mandril which extends through the nose and is supported on the tail-stock centre. The body of the mandril also acts as a positioning stop inside the nose so that the thickness of the nose is

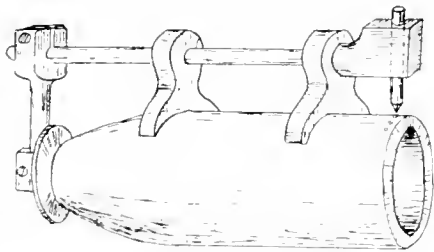

FIG. 9. SKETCH OF LENGTH GAUGE WITH PRICK PUNCH.

duplicated in every shell; up till now the base end has been left as it came from the cutting-off machine, that is, with a small allowance for trimming to size.

Great care is taken to see that the mandril dogs are kept true, grinding being done at regular intervals to insure concentricity between the finished bore and the exterior which is now being

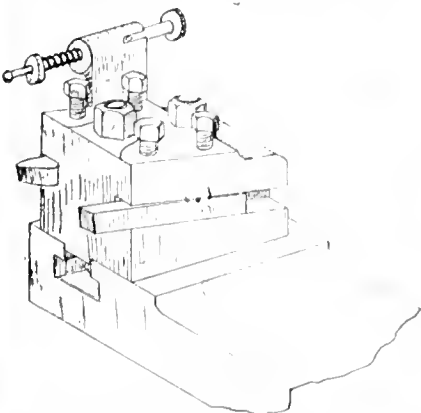

FIG. 10. SKETCH OF TOOL BLOCK USED IN BASE FACING AND RECESSING

finished. Standard 30-in. C.M.C. engine lathes are employed, the profile being obtained through template bar mounted

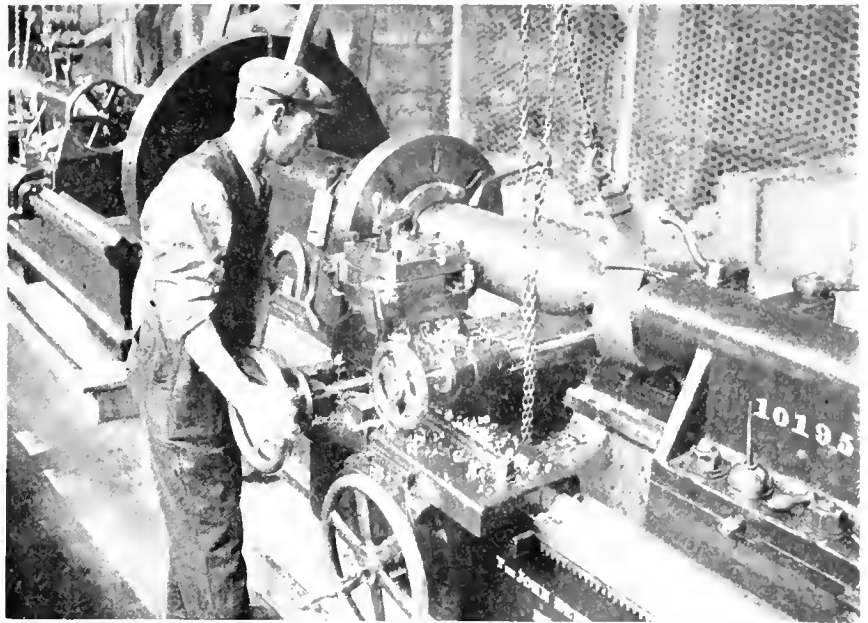

FIG 10a. GROOVING AND WAVING FOR COPPER BAND.

at back of bed. As the template and the mandril are fixed in relation to each other, uniformity in thickness of nose wall is assured.

The cutting tool is of the circular cup type which gives maximum length of cutting edge with one sharpening (see Fig. 8), and gives a clean, smooth surface on the work. These lathes are all belted up on the middle step of the cone and fitted with two-speed countershaft which enables the operator to speed up on the nose as the diameter decreases. Speeds provided are 93 and 157 ft. per min. This high rate of cutting is largely due to the use of shell forgings made from cast billets, the texture being very uniform and the cutting qualities much superior to forgings made from rolled billets.

Finishing Nose

All of the finish machining on the nose with the exception of threading, is done in two Davis turret lathes with four-tool equipment consisting of flat

level cutter for mouth of hole, single point boring cutter, recessing tool, and two-diameter reamer. The base of the shell is carried on an expanding arbor operated by handwheel while the body is supported by a steady rest at the end of the parallel portion. The peculiar properties of the cast forgings gave some difficulty in obtaining a suitable material from which to make jaws of the steady rest. Hardened steel had too much tendency to heat and tear up the surface, brass was much better but did not last, while cast iron was a moderate improvement on brass. Chilled faces on the end of the cast iron jaws proved very satisfactory, giving a long life, with almost entire absence of heating, and no detrimental effect on the surface of the shell.

Weighing Dispensed With

With the exception of the base end, all of the shell is now machined to exact sizes with no limits. It follows,

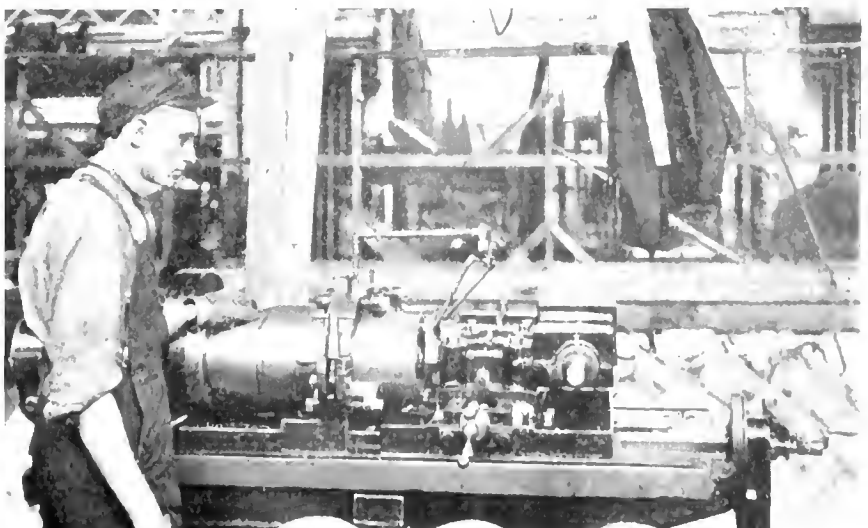

FIG 11. MILLING BASE THREADS IN DUPLEX MACHINE

therefore, that if the length be made exactly to a uniform dimension, the weights of the various shells will be exactly the same, except for any slight variation in density of the metal which is entirely negligible in actual work. The shells, therefore, are now marked for overall length by means of a prick-punch gauge (Fig. 9), and are passed over to the base finishing operation which employs three Bridgeford 26-in. engine lathes with draw-in collet chucks and outer steady rest.

The tool carriage of these lathes is fitted with a special tool block having two tools and an indicating gauge. A sketch of this is shown in Fig. 10, which shows the tool block bolted in place of the ordinary tool post. Tool A is beveled off to a round point, and is used for facing off the end of the shell to the punch marks. Tool B is then moved across to position, and fed into the end of shell, forming recess for adapter flange. The spring indicator C, is mounted so as to bear against the finished end of shell and show when tool B has cut to the required depth. Tool A is now used for chamfering the ragged edges on inside and outside of shell, which now proceeds to the grooving machines.

Grooving and Waving

Three special Bertram grooving lathes are used, with positive eccentric drive to waving tool. A four-sided revolving tool post enables the grooving, waving and undercutting to be performed in rapid succession. The reciprocating drive for waving tool is by a back shaft from the end of headstock, a clutch operating lever being located within easy reach of the operator on the front of the headstock.

The threads in nose and base are now milled in Bertram milling machines. The nose is done first, the shell being



FIG. 13. COPPER BANDING EQUIPMENT.

gripped in a draw-in collet chuck and supported in steady rest. In actual operation the spindle is allowed to revolve continuously, while the shells are being inserted and removed, the speed being about one revolution in 20 seconds. The carriage is fed along by lead screw to coincide with pitch of cutter, a clutch on the lead screw shaft allowing the cutter to be moved to position, and split nut engaged, after which the clutch is thrown in and the cutter fed into proper depth by hand. A suitable vise on the conveyor track allows the thread to be sized by hand tap before going into the base threading machine.

Owing to the greater amount of work

on the base thread, two duplex Bertram machines are required to handle the volume of work which is done by the nose threader. The operation is very similar, the principal difference being in the method of holding the work. Conoidal plugs with threaded rods are placed inside the shell noses and engage with tapped hand wheels at the back end of spindle. The milling cutters are carried on independently adjustable blocks mounted on the cross slide of carriage, which in turn is fed along by lead screw. Hand tapping to size, followed by cleaning completes the shell for preliminary inspection.

After passing inspection the shells

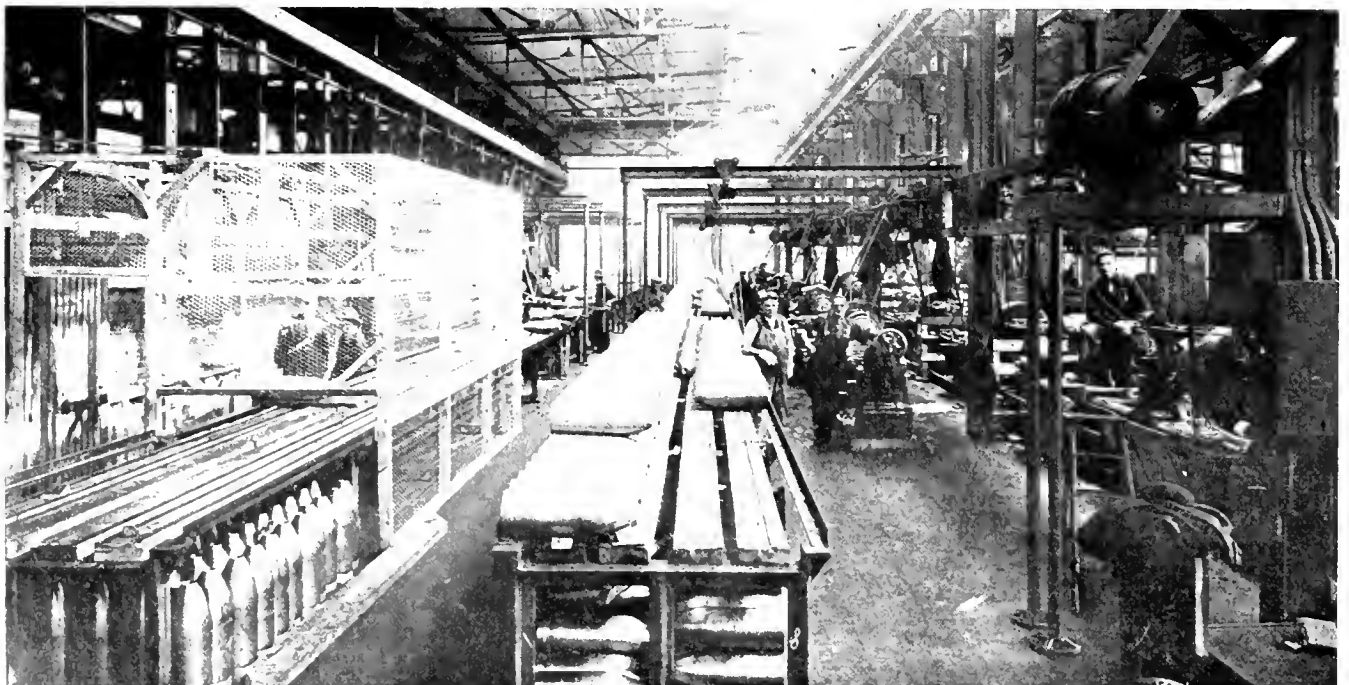

FIG. 12. VIEW OF BAY SHOWING TRACKS FOR WORK AND PRELIMINARY INSPECTION CRIB.

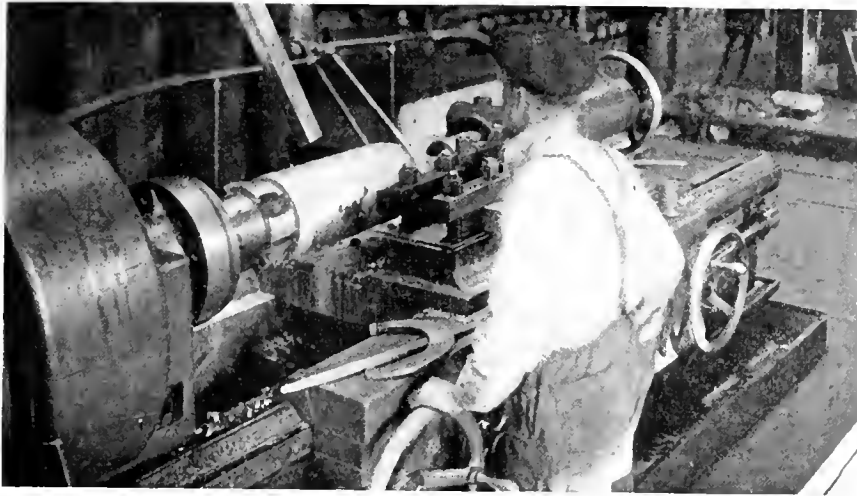

FIG. 14. BAND TURNING MACHINE SHOWING TWO TOOLS ON SLIDE BELOW WORK.

receive the adapter which are tried into place by hand, and in nearly every case go within half an inch of being home. This is due to the very close limits within which the threaded work is held. A satisfactory fit having been assured, the adapter is withdrawn, coated with cement and inserted for good, being driven home in a special driving machine built by Root & Van Dervoort. This consists of a suitable framework at one end of which is a pneumatic clamp which holds the shell in line with the driving spindle. The spindle is geared up to a 4½-in. belt, and has a sliding head with two pins which engaged the holes in the adapter. The operator causes the head to follow the adapter by pedal-operated toggle gear, and maintains it in engagement until the belt slips. A characteristic ringing sound when struck with a hammer indicates that the adapter is hard down in the recess.

Banding and Facing

Banding follows immediately, being accomplished in a twelve-cylinder press with four-throw pump, the entire outfit being supplied by the West Tire Setter Co. Heating the bands is resorted to, to insure a perfect fit on the threads and a proper filling into the undercuts. A gas-fired furnace with capacity for three bands, keeps pace with the work, the bands having a temperature of around 1,200 degs F., which combined with the cooling effect of the dies gives a desirable annealing to the copper in situ.

The adapter joint is riveted and faced-off in suitable engine lathes having special tool boxes fitted to cross slide of carriage. These tool boxes have a pneumatic riveting hammer of ordinary type securely clamped to a cradle, provided with a spring mounting which absorbs excessive vibration from the hammer. One revolution of the shell with the hammer in operation serves to close up the adapter joint in good shape, after which the tool box is traveled across, bringing a facing tool into action which in turn is followed by a

radius tool for rounding the corner of the base.

Varnishing and Baking

The nose is finally tapped to gauge and the bevel seat reamed with a special cutter supported on an expanding arbor in the threads, thus insuring the seat being true with the threads. After a thorough cleaning with gasoline and a blow-out with air, the varnish is applied with an Eclipse air brush, a protecting bushing being inserted in the nose to keep the varnish out of the threads. This method gives a very even coating with a minimum amount of varnish which allows of the shells being baked right away without loss of time due to draining off excess varnish.

The type of oven adopted is that in which a separate heating element is inserted in each shell, the elements being suspended from a hood which is lowered over the shells. Nine shells are baked at a time in each unit, the base having sockets which space the shells accurately to correspond with the heat-

ing elements. Six units suffice to handle the output, the time of baking being reduced to a minimum through the method of applying the heat.

Band Turning

The shell is chucked in the hollow spindle of the band turning machines, which have a roughing and a finishing tool arranged to travel toward the front of the machine, sizing and forming the band as they pass underneath. These Root & Van Dervoort machines have the cutting edge of the formed tools

shaped away at an angle so that the cuttings leave the tool in a backward direction, being deposited behind the machine out of the way of the operator. After turning, the tools are traveled back and a tool rest in front brought into action which bevels the right side of the band, cleans up the opposite side.

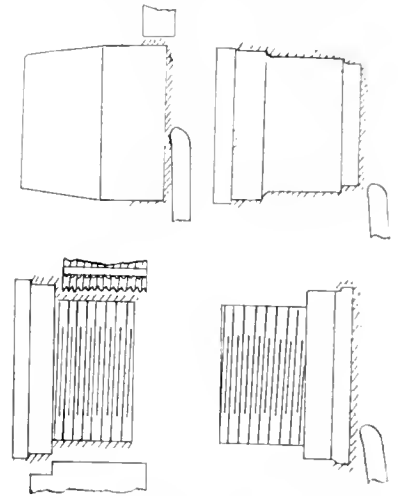

FIG. 15. OUTLINE OF OPERATIONS ON ADAPTER.

and sizes up the square groove in the middle.

Weight Checked

The shell is now cleaned out with air, and passed over scales for the first and

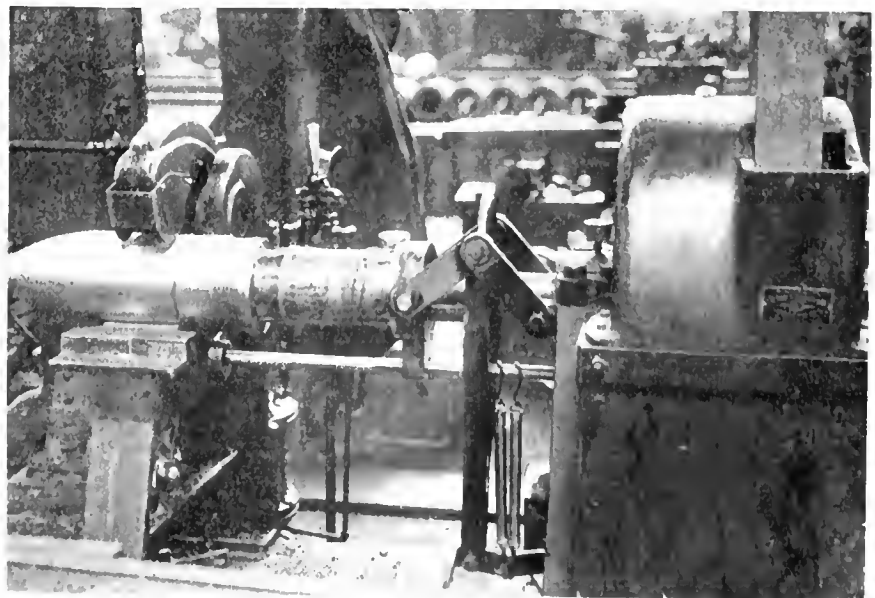

FIG. 16. ADAPTER DRIVING MACHINE

last time during manufacture. The finished weight of shell is 177 lbs + 14 ozs., and — 1 lb, 12 oz. A number of shells taken at random showed no appreciable variation above or below which proved that not only could suitable dimensions be determined, but that they can be adhered to with a high degree of accuracy dispensing with much time, which is considered necessary in adjusting weights both in the course of manufacture and also at the conclusion.

The concluding operations are well-known to most of our readers, and call for no special reference. The remaining space shown on the layout is occupied by the final government inspection, a Brown Boggs marking machine, and boxing operations. After boxing, a number of shells are piled on suitable sized platforms and transferred by overhead traveling crane to a freight car on the track shown.

Adapter Machining

A few points in the adapter work are of interest, one being the fact that standard types of machines are used throughout, and another, the method adopted of insuring that the threads and joint face of flange are absolutely true with each other.

The work is divided into five stages as in Fig. 15. Operation No. 1, is done in Hall pipe machines, with two tools which approach each other so that the finish of the operation finds them in the position shown. Operation No. 2, is done in engine lathes which chuck by the previously machined diameter. Operation No. 3 is done in a small drill press with universal chuck and locating device. Operation No. 4 is done in engine lathes fitted with a thread milling attachment on the back of the carriage and a special slow speed drive to spindle through gearing at back of head stock.

The machines used for this purpose are C.M.C. 26 in. heavy duty lathes. Considerable rigidity is necessary to secure a satisfactory thread, close adjustment of the spindle bearings and carriage being maintained at all times. The formed turning tool which finishes to size is accurately set up to produce all diameter parallel, and face the flange perfectly square with the body. The milling of the thread follows without the work being rechucked so that the required accuracy is obtained continuously, and with no call for excessive skill or care on the part of the operator. Operation No. 5 consists of chucking by the threaded body and facing off the excess material on the base, leaving sufficient metal to clean up comfortably after riveting the joint in place.



FUTURE OF CANADIAN IRON AND STEEL

THE future of the iron and steel industry in Canada was the subject of a symposium at a session of the Canadian Mining Institute convention held recently. What has been ac-

complished to date was made the basis for remarks as to the prospects for the future, and there seemed to be a general inclination to believe that the industry in Canada needed Government bounties or tariff protection, to enable it to compete successfully with the United States.

Corbett F. Whitton led the discussion by a paper which named all the various companies interested in the iron and steel industry in Canada. Each plant was described with what it manufactured, and the special advantages of each over its competitors were shown. At present the iron and steel industry of Canada is dependent almost entirely on supplies of iron ore from outside sources. On the Eastern Coast the supplies come from Newfoundland, while the Algoma Steel Co. and the Steel Company of Canada, Hamilton, Ont., get their supplies from the United States.

On account of cheap water transportation from Newfoundland, and the coal readily available from the mine, the companies in Nova Scotia were favorably situated. Metallurgical coke for smelting purposes was the essential thing in the iron industry, and with both these advantages at Sydney, the Nova Scotia Steel & Coal Co. and the Dominion Iron & Steel Co. should be able to produce iron just as cheaply as anywhere in the world. The Algoma Steel Co., was built primarily for the purpose of manufacturing steel rails at the Soo where iron ore and coke could be assembled from American ports by reason of the cheap lake transportation, and where the company would be favorably situated to command markets both East and West in Canada.

On account of changing conditions in Canada and the possibility that there will not be railway construction as in the past, the Algoma Steel Co. is going into the manufacture of rolled steel sections, and extensions to the present plant for rolling structural steel for building, bridge and other purposes up to 24 or 36 inches, are contemplated. There was little doubt but that other companies were considering similar extensions.

D. H. McDougall, of the Dominion Iron & Steel Co., pointed out the importance of the iron and steel industry to Canada, it being the basic industry on which all metal products depended. Everything possible should be done to encourage such an industry.

Magnetite Deposits

R. R. Hedley, from British Columbia, said that his province had no iron and steel industry, but that there was a large market there for iron and steel products. The drawback against establishing an industry there was the uncertainty of getting a supply of suitable iron ores. There were large magnetite deposits, but no large hematite deposits. The magnetite deposits, however, sometimes contained as high as 15 per cent. of copper. It would be possible by the electro-magnetic separation of the iron from the copper to recover both. That should be profitable, especially in con-

sideration of the fact that the Vancouver Island coals were suitable for the manufacture of metallurgical coke. Already 3,000 tons are produced monthly to be used in connection with the smelting of copper in British Columbia. Everything possible should be done, in his opinion, to encourage the industry in British Columbia.

One speaker, in the general discussion, said he did not want to talk politics, but he did not think that the Government had fully protected the iron and steel industry on account of the fact that the tariff was not made general, but particular in character. As an example he said that plates for ships, construction and boilers were practically admitted free while there was a duty on other plates. One of the essentials in the manufacture of iron and steel products was a large output, and if certain steel plates came in free it reduced the market of Canadian companies for steel plates.

A gentleman from Deseronto said that he represented the smallest steel industry in Canada. In Deseronto the problem was to get suitable ores. The ores which the Deseronto concern used or experimented with, came from the Moose Mountain district in Northern Ontario, and were magnetites. The present methods of treating magnetite were too costly, and he thought that the Government should carry on investigation so that the iron and steel industry could be established on the basis of using Canadian ores.



ELECTRICAL PROCESSES IN METALLURGY

A MORE than usually interesting address was given last week, at the Shanghnessy Building, Montreal, by George M. Berry, chief chemist of the Holoomb Steel Co., of Syracuse, N.Y., and inventor of the process by which hydro-electric power has been commercially applied to metallurgy. The lecture had been arranged by Arthur D. Little, Ltd., under the auspices of the Canadian Pacific Railway Co., with a view to showing what could be done to use undeveloped water powers in Canada to develop other industries, and especially the electrical production of high grade steel. J. S. Dennis, assistant to the president of the Canadian Pacific Railway, introduced Mr. Berry, there being an audience that taxed the capacity of the room.

In his address Mr. Berry was decidedly technical, illustrating his talk with a series of lantern views, showing the development of the electric furnace. He emphasized the fact that the steels required at the present day on this continent could not be made here, were it not for the electrical furnace, owing to the absence of suitable clays and graphites for the ordinary production of crucible steel.

These electrical processes, he demonstrated, had really saved the situation in Canada, especially during the past two years.

PRODUCTION METHODS AND DEVICES

A Department for the Interchange and Distribution of Shop and Office Data and Ideas Evolved from Actual Practical Application and Experience

SAVING MONEY ON PLANER KNIVES

By H. Middletown.

EVERY wood-working establishment that boasts one or more planers or jointers has some worn out knives laid up on a shelf or in the pile of scrap metal out in the back yard. These knives, or blades, have been worn to the limit that

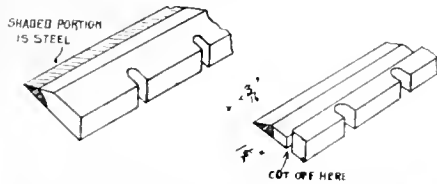

SAVING MONEY ON PLANER KNIVES.

it is possible for the bolts in the head to hold them securely but not one in twenty is worn to the limit of its steel cutting face as an examination will show. The knives in this condition are as shown in the drawing which shows that although the bolt slots are short, there is still a goodly portion of the steel left.

Now in addition to the worn out blades, there is usually a pair of good ones with every one of the old style heads that have been taken out to meet insurance and factory regulations and which have been replaced by the round, safety heads. These round heads, as everyone knows, take a thin flat knife which is all steel and an average size of which would be, say, 3/16 in. x 1 1/2 in. Now, instead of buying these new knives, they can be made out of the discarded ones at a material saving.

A discarded knife 24 in. long would be from 2 1/2 in. to 3 in. wide and can be taken to a machine shop and cut to the

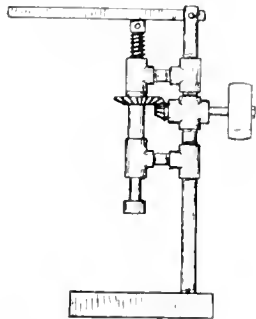

THREE DOLLAR SENSITIVE DRILL.

3/16 in. x 1 1/2 in. size in a few hours. The way in which they are cut is shown in the drawing. Note that the metal is planed off the "back," leaving the 3/16 in. of composite cutting edge. Then a slotting tool severs the notched portion and leaves a good new blade. This extra notched portion gives a width of surface for clamping on the machine shop planer

which is very handy and contributes to a marked degree to the low cost of the job. If the shop has a milling machine of No. 2 size or larger, the work can be done on it in even less time and the cost of altering a pair of 24 in. knives should not run over \$2.25 which is a fraction of the "new" price. If more than one pair of old knives are available, the lot should be done all at once and get the benefit of quantity prices.

Some good wood men claim that the old knives had better steel in them than modern ones. If so, this is the way to reclaim it. At present the quality of steel might not be up to the old standard -- neither are deliveries at all prompt--all this favors re-cutting. After re-cutting, the knives will be found curved, but they are easily straightened on a block.



A THREE DOLLAR SENSITIVE DRILL

By D. A. Hampson.

MY friend Charlie Marks had been running a country blacksmith shop about a year when I dropped in to see him. In that time, his trade had increased--also he had accumulated a creditable pile of scrap--and he told me he wanted to buy a post drill; this drill was to be power driven, for he was up to date, and al-

ready had a motor to drive the forge blower--cheap electric current being available in the village.

Now a country blacksmith, like the minister, must take his pay in the coin of the realm and also in commodities, i.e., vegetables, cord wood, labor, and scrap iron; included in this latter item had been an old chainless bicycle, and as my wandering eye took in this relic, the pair of bevels at the crank suggested the right angle drive of a drill press and around them, I mentally built a machine, that for cheapness and perhaps crudeness, combined with utility, would be hard to beat. Charlie was enthusiastic over the scheme and furnished me with the bevels and a shaft from the bicycle, a twelve-inch pulley, and a chunk of cast iron that was to be the base or table. "I'll furnish these things and will forge the feed lever and you can do the rest," he said, as I left.

How the machine looked may be gathered from the drawing. The pipe fittings and the nipples came from a plumber's shop and cost \$1.47. These fittings were assembled, the shaft laid in, and the spaces filled with babbit which Charlie had dug out of two old saw bearings. The base was pipe tapped, the pinion shaft turned to a shoulder, the spindle keyseated and a hole drilled for his 3/8-in.

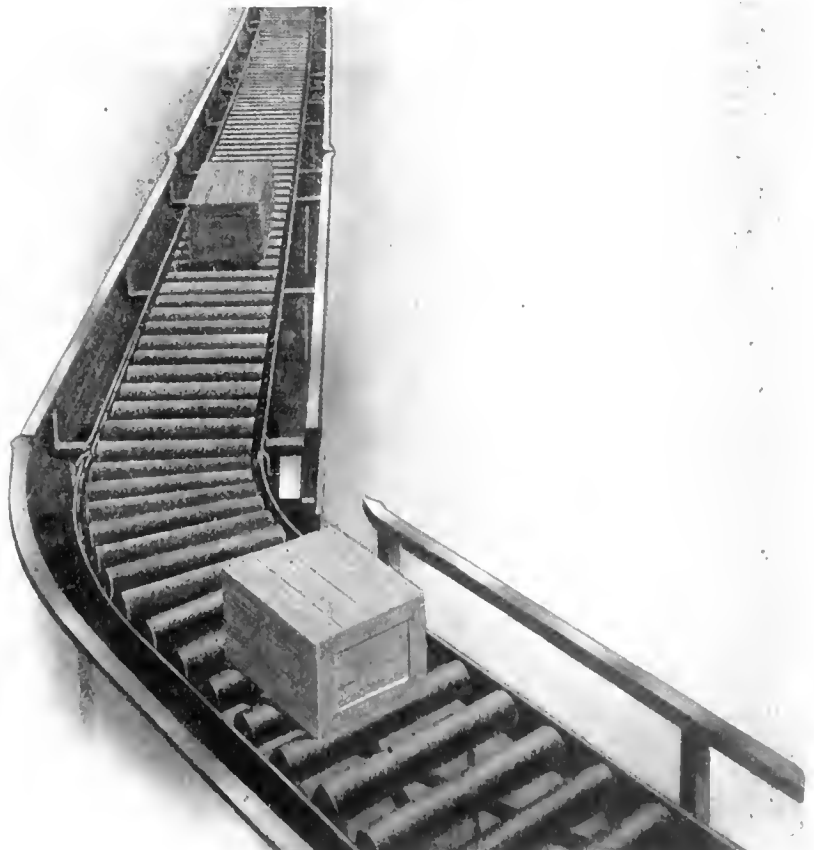

FIG. 1. STEEL BALL-BEARING GRAVITY ROLLER BOX CARRIER OF 1% GRADE.

straight shank blacksmith drills. The labor involved took three hours at sixty cents, so the machine stood Charlie in a grand total of \$3.27. And it really did good work and was quite rigid. The collar which reinforced the spindle, the spring return to the spindle, and the feed were added after the machine got in the hands of the blacksmith.



CONVEYOR EQUIPMENT IN CARTRIDGE CASE PLANTS

By M. J. Anderson

THERE are many interesting operations performed as well as devices employed in connection with cartridge case manufacture, and the conveyor systems and equipment used in these plants for handling their commodity is among the most interesting from an engineering point of view. Due to the high cost of labor and its apparent scarcity, the subject of conveying and labor saving machinery has come into prominence, and is being given due consideration by up-to-date shop executives.

Conveyors are used to-day to a far greater extent than ever before, and the munitions manufacturers were quick to realize that large savings in labor time, and space, could be made by their installation. The types of conveyor being adopted for munition plants indicates that the subject has been thoroughly canvassed with respect to adaptability, flexibility, and economy of space, also relative to initial cost and maintenance. Whether in a billet cutting plant, forge shop, fuse shop, pow-

*Superintendent, Canadian Mathews Gravity Carrier Co., Toronto.

der plant, cartridge case or other branch of munition manufacture, conveyors can be seen speeding up production.

With a combination of gravity and

quickly filled or emptied. Manufacturers are often limited to floor space. Goods are loaded direct to incline power sections or elevators that raise them to



FIG. 3. STEEL BALL-BEARING GRAVITY WHEEL BOX CARRIERS OF 4% GRADE.

power conveyors working in conjunction, receiving and discharging automatically from one to the other, several handling problems have been solved. A minimum amount of floor space is required, and the surface is often used for storage or as a working table, goods being moved along as required from one operator to the next. The gravity carriers are made up in sections and are readily portable and can be used at different points or by adding on or taking off sections along main line, various positions can be reached. By using one main line of carrier down the centre of a building and using curves and branch portable lines down aisles, large rooms of stock are

required heights, and discharged onto lines of gravity conveyors. These convey over head any required distance and discharge on end with chutes to floors or tables.

There are many combinations of arrangement possible, and complete conveying systems are fitted to suit the peculiarities of different conditions. To meet these conditions many ingenious designs and variations of construction have been required, some of them being both unique and interesting to both the casual observer and the engineer. The gravity carriers here described are of two types, wheel and roller.

The wheel type illustrated in Fig. 1 is made up of two rows of steel rails riveted to cross and lateral braees, the rails being spaced a required distance apart to suit the package to be handled. At close centres on the outside of these rails, ball bearing wheels are bolted, making two continuous rows of wheels the length of the conveyor. These wheels are about two and three-quarter inches in diameter by five-eighth inch face and revolve on a nine-sixteenth inch diameter cone which makes it very light running. It can be readily seen that these make a very light running apparatus that requires very little grade to operate and in many cases requires only from two to three foot fall in one hundred feet of carrier. Any number of sections can be connected to make continuous lines of any desired length, both straight and around curves. With these sections of carrier and the additional use of power elevating sections and chutes, many combinations have been worked out to meet varying conditions. Such a type of carrier is used extensively in conveying boxes with metal or other bands around the edges, and is adapted to the handling of cartridge case boxes. These boxes ride on the conveyor crosswise with the ends projecting out four or five inches outside the rows of wheels so that the bands at ends do not come in contact with, or interfere in

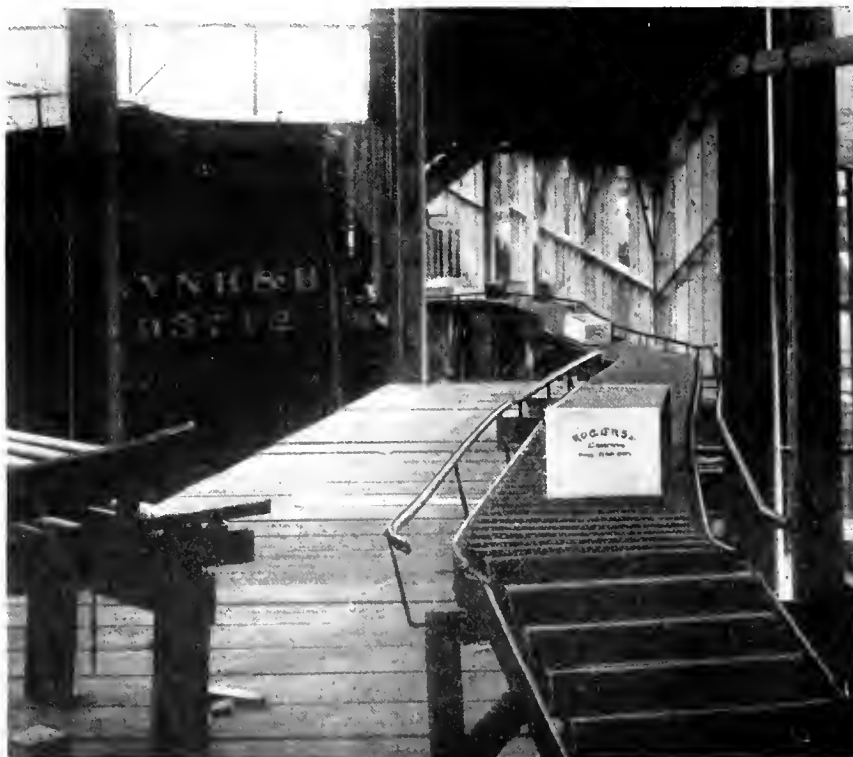

FIG. 2. SYSTEM OF STEEL BALL-BEARING GRAVITY BOX CARRIERS LOADING CARS.

any way with the conveying surface. In the same way the middle band, if there is one, passes between the rows of wheels. These carriers are in extensive

or adding additional curves and straight sections any part of the available space can be reached. This method has many advantages over trucking, in that it

As boxes are taken off the end, the whole line moves up so that it can be always kept full from loading end. This line of carrier leads to packing bench where finished cartridges are placed in for shipment.

In the shipping room are stock piles of finished cartridge cases in trays ready for the final stamp before packing. Two lines of carrier lead from these stock piles to stamping block where each cartridge case is taken out and given its final stamp. The lines are continually filled up with trays, each of which holds about twenty cases. There is a line of roller carrier from this stamping block through a door in the building across the platform to car at siding. As fast as these cartridge cases receive the final stamp they are packed in boxes and are ready for the covers. The packing is done at the start of this line of carrier and the covers are put on by operators along each side. The roller carriers are used for this work, because they afford a working table for the workmen and are more substantial in their construction. Supports on castors are put under the sections outside of building leading to car. With this method of handling boxes and trays, cartridge cases are handled for shipment with remarkable precision and speed, in a minimum amount of time, and the economical use of space.

There are a number of other more or less minor operations facilitated with these carriers, one of these being the conveying of trays from inspectors to stock piles in shipping room. Under different conditions it has been found necessary to use power elevating devices to raise boxes where various elevations are required. Fig. 3 shows a portable adjustable incline elevator used for this purpose. This receives and discharges automatically in connection with either type of gravity carrier and is used to great advantage where conditions require changes in height and location of stock piles or cars.

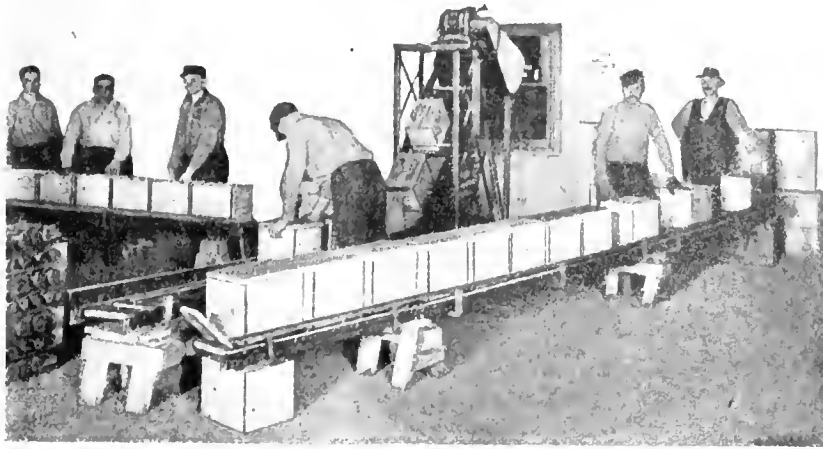

FIG. 4. CARRIERS AS INSTALLED IN A TEA BLENDING ESTABLISHMENT.

use in various plants manufacturing cartridge cases.

The roller type of gravity carrier illustrated in Fig. 2 is constructed along more substantial lines than the wheel type and because of its construction is adaptable to a wider field in the variety of commodities that can be handled on it. It is employed in nearly all branches of munition manufacture, forging shops, machining shops, cartridge case, fuse and powder plants being among the more extensive users. This is constructed of ball bearing steel rollers of any required length set in a securely braced frame at any suitable spacing to accommodate the article to be conveyed. With this carrier, like the wheel type, many combinations have been worked out, and many very interesting systems are installed. These are also extensively applied to handle cartridge case boxes, and lines of these carriers are used as a working bench for the final filling of boxes and screwing down the covers. Cartridge case manufacturers were among the first of the munitions plants to see the advantages of gravity conveyors, and many shops are to-day equipped with extensive systems of gravity and power conveyors.

Unloading cars of empty boxes to the box storage building is one of the first items of consideration and the time required to empty a car has been cut in two. Portable sections of wheel type gravity carrier are used and when the car is set, a line of these carriers is set up from the car door to the point in the building where boxes will be piled. By means of a coupling device these sections are quickly hooked together and are set up on adjustable stands or jacks. Setting up the carrier requires but very little time. Boxes are placed on the carriers which move them away as fast as two men can place them on and are taken off at the other end and piled by two or three men. When one section of the storage space is filled up, the carrier line is shifted, and by taking off

saves the time of loading and unloading trucks and the time required for returning, also the wear and tear on floors and trucks. These carriers can be run down narrow aisles and can make turns where trucks could not be used, allowing more floor space for storage.

The next operation with the conveyors is getting these boxes from the storage to packing and shipping department. The wheel type of carrier is also used for this. A main line of conveyor is permanently installed from the storage room to stock pile in shipping room, and, to this, connections are made in the storage building by means of portable sections and stands to meet any required point from which boxes may be required. Boxes are loaded on to conveyor and are taken off in shipping room where quantities are stocked to be used as required. These conveyors are often filled up with boxes and are a means of storage for immediate require-

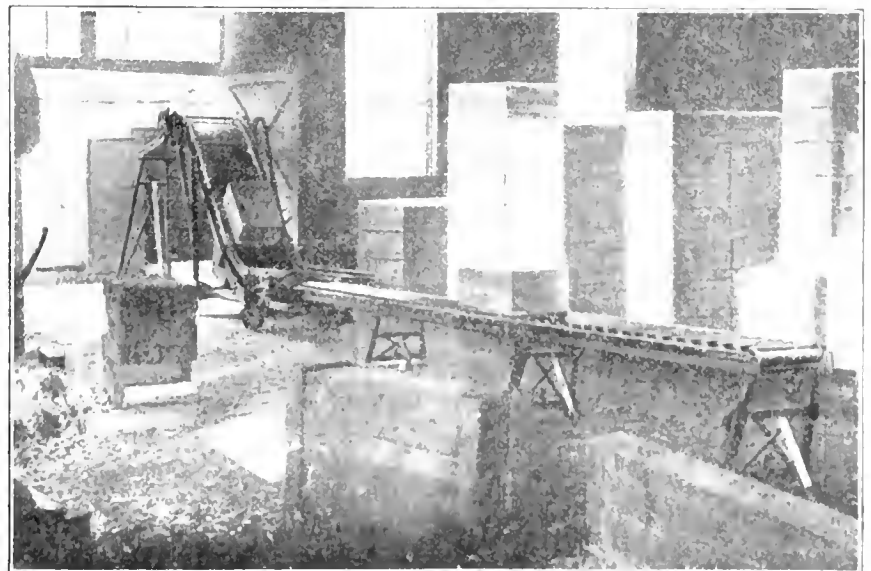

FIG. 5. CARRIERS DELIVERING TO INCLINE PLATFORM ELEVATOR LOADING CARS FROM STOCK PILE.

There are other branches of munitions manufacture that have used gravity conveyors more extensively than that of cartridge cases, but considering the nature of the product and methods of production, the different plants are applying them proportionately wherever their use will mean increased production and a saving of time and labor.



GLOBE VALVE EXPERIENCES

By J. E. McCormack.

WITH regard to globe valve experiences the writer likes to have two globe valves on the steam supply pipe to the injector or pump, just on the same principle as one likes to have a globe between the check valve and the boiler, or a stop cock between the boiler and the throttle, because if one fails he has the other to "fall back on," as the phrase goes.

Some years ago he was in charge of one of those plants having only one globe between the injector and the boiler steam space. This globe was of the type in which the face was an internally threaded member and was screwed onto an externally threaded member which in turn fitted behind a shoulder on the valve stem. All went well for a few weeks, then one morning the face dropped from the stem and lodged in such a way as to render the injector inoperative. As there was no other feed-water system installed, and only one boiler used, there was no option but to get the steam off, fix the valve, and raise steam again, thus causing a delay involving more or less financial loss to the proprietor, and which could have been avoided had there been another valve next the boiler with which to shut back the steam while the defective one was being overhauled.

Choosing a Valve

It was then decided that an additional valve should be in for meeting such an emergency should it recur, and the writer was asked what make of valve he would prefer. It was only natural that he be expected to name what was then the valve most advocated by old hands, but he was young, enthusiastic and self-willed. He wanted one which, for holding the face in place, did not depend on a nut or screw which might come loose and drop the face, or, if made too tight, would perhaps stick, and refuse to budge without breaking. A valve answering to these requirements had been described in your publication. The local dealer did not stock them, but a look or two through the advertisement section disclosed the whereabouts of a sales house, and a few different sized valves and discs were ordered by letter. The only tool required when changing the discs is a wrench that will remove the bonnet; this done the old disc can be easily removed from the stem by hand and a new one slipped on. When the bonnet is returned to its place it is impossible for the disc to get out of position.

Emergency Babbiting

After a time it was found that the supply of discs for one size of these

valves was nearly exhausted and to make it hold out a little longer (owing to no local dealer stocking them as aforementioned), the writer took a cue from the soft metal faces of some lubricator plugs. The old asbestos face was dug out and its place filled with melted lead. This lasted for two days, at the end of which time it had squeezed out too much. Melted babbitt metal was then tried, and as it gave very good service it was used on this size of valve for some time. An acquaintance tried the babbitt on a make of valve which used a nut to hold the face in place and effectively locked the nut by pouring in enough metal to entirely cover the said nut.

Although the writer was, and is yet, well pleased with his chosen make of valves, he has known them to be criticized by other operators, each of which had a preference of his own for some particular make, but on one occasion when talking with an engineer about valves in general, the engineer remarked, "I like those — valves. For one thing, they are a valve you are never stuck with. The discs are easily changed, yet won't come off unexpectedly, and if you should happen to run out of discs you can remove the old face, pour in some babbitt, true it up a bit and go on again." Now, my object is not the boosting of any particular brand of valves, but what I want to impress is that this babbitt habit has helped out of difficulties at times and a few men have begun to look to it as one of their stock emergency measures. With this fact in mind we are ready for another experience, which came to the writer's knowledge just recently.

Conditions Must be Studied

The globe on an injector steam pipe was bad and no proper face for that make of valve readily procurable at the time, a few days' delay being normally unavoidable under existing circumstances, and so the operator tried the babbitt scheme for the first time. His boiler was an upright one with this globe placed close to it. Before being in use long his injector balked and investigation proved that some of the babbitt had melted and been carried down into the injector steam jet. Evidently some of the metal had also lodged in the elbow, for after a reliable face had been inserted the injector was twice put out of action by plugging with babbitt. The brand of babbitt used may have been rather easily fused, but the writer's personal theory is that since the boiler was an upright one, the steam became at times sufficiently super-heated to melt babbitt. Anyway, this latter experience proves that though some have been helped by thus using this metal it may perhaps be worse than useless wherever any degree of super-heat may even possibly exist, and "by the same token," when trying out only one valve of any make and in comparison with other valves in service it may, if placed as above-mentioned or in any other position where super-heat may get to it, ap-

pear to use softer discs than other valves when in reality it is being put to a more severe test than is the valve or valves, it is being compared with, yet without the operator suspecting that such is the case.



INDUSTRIAL DEVELOPMENT OF EASTERN CANADA

THE industrial development of Eastern Canada is continuing at a remarkable rate. Many new industries are locating in this territory each month; big, new plants are being erected and many of the established concerns are making large additions to their factories. Wm. P. Fitzsimons, Commissioner of Industries, Grand Trunk Railway System, states that new plants representing a capital investment of nearly \$12,000,000 have been placed along the company's lines within the last twelve months. These new industries number approximately seventy-five and will employ more than 10,000 hands when in full operation. An additional \$5,000,000 was spent in that period in extensions to manufacturing, providing work for another 4,000 men.

Among the largest of the industrial concern to secure locations served by the Grand Trunk, during the past year, were the Dominion Sugar Co., at Chatham, Ont.; British Munitions, Ltd., Montreal; St. Catharines Steel Metal Co., at St. Catharines; Kellogg Toasted Cornflakes Co., at Toronto; Dominion Dustless Sweeper Co., at Peterboro; and William Kennedy & Sons, Ltd., at Collingwood, Ont. These six plants alone represent an investment of approximately \$3,000,000.

Among the plants under construction is a large refinery at Port Colborne, Ont., for the International Nickel Co. of New York and New Jersey. The building of this plant is of national importance, not only because of the large investment involved amounting to several million dollars, but because it places within the Dominion the refining of invaluable nickel ore, and the distribution of the finished nickel, work which had been previously done outside of Canada.

Since 1910, five hundred industries with a total investment of about \$100,000,000, have been located along the Grand Trunk Railway. This splendid work in building up Canada's industries has been greatly facilitated by the traffic department of the railway, to which the Industrial Commissioner and his staff are attached. The Grand Trunk traffic men, under the direction of Vice-President Dalrymple, are indefatigable in their efforts to help manufacturers find suitable locations.



The Canadian Steel Corporation, Ojibway, Ont., have not entered into a contract for power with the Hydro-Electric Commission of Windsor, Ont., as stated in a recent issue. The contract referred to was made by the Canadian Salt Co., Sandwich, Ont.

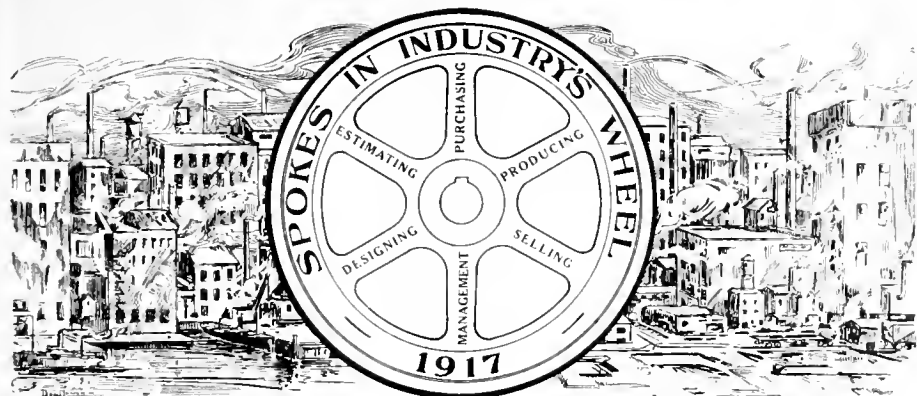

The constitution of industrial enterprise is largely departmental—"spokes in a wheel." This series of articles has for its object the featuring in a racy, interesting and instructive fashion, the training, experience and achievement of those who to-day are transmitting, effectively, energy in their capacity as "spokes in the wheels" of our metal-working establishments.

PERCY OSCAR GORDON JANES

EQUALLY important as the generation of power is that of its transmission, and just as there is in the former a wide variety of appliance and mechanism employed, also large opportunity for the exercise of individual genius and expert skill, like conditions may be said to generally prevail in the sphere of the latter. In a word, power generation and power transmission, as regards improvement and development, should go hand in hand, otherwise the efficiency achievement of either becomes to a lesser or greater extent curtailed if not nullified. It is quite apparent, however, from a close study of power engineering that both departments are forging ahead and keeping step, so to speak, by taking full advantage of each other's latest creations. The subject of this personal sketch, as will be noted, is largely interested in the transmission feature — to wit, ball bearing equipments.

Percy Oscar Gordon Janes, sales engineer and manager, the Canadian S K F Company, Ltd., 47 West King Street, Toronto, Ont., was born at Bury, Lancashire, England, January 31, 1885, his father being William Alfred Janes, and his mother, Emma Milson. He was educated at the day and technical schools, Bury, also attending the evening classes at Salford Technical Institute. He afterwards took a six years' engineering course at Manchester School of Technology—part day and part evening, passing the Mechanical Engineering examination of Manchester University as an external student.

At fourteen years of age he became apprenticed to Robert Hall & Sons, Ltd., textile engineers, Bury, graduating from the shops to the drawing office. Five years later he joined the drawing office staff of Galloway's, Ltd., Manchester, in which capacity he acquired considerable insight and experience relative to the design and construction of high-grade steam engines of various types. After concluding another five-year term at Galloway's, he became associated with Daniel Adamson & Sons, of Dukinfield,

near Manchester, occupying the dual position of draughtsman and superintendent of outside erection in engine department; being later transferred to the Rateau steam turbine branch of the firm's activities, with charge of the turbine drawing office.

The next move of our "Spoke" was



PERCY OSCAR GORDON JANES.

overseas to Canada, for in 1911 we find him on the staff of T. Pringle & Son, consulting engineers, Montreal, as mechanical engineer and draughtsman. With the lapse of twelve months, by which time he had not only found his "bearings," but had become alive to his adopted country's opportunities, the desire for personal enterprise had taken hold of Gordon, hence his establishment of a business partnership under the title of the Engineers' Representative Co., of Montreal, to act as sales agents for several English concerns, among whom was

the Skefko Ball Bearing Co., of Luton, Bedfordshire; marking, as a result, the introduction of the S K F ball bearing to Canada.

The demand for this type equipment began to increase quite rapidly right from the start, and finally became such as to tax the financial resources of the partnership. The Canadian Fairbanks-Morse Co. stepped into the breach, however, by mutual consent of the various interests, and to enable our "Spoke" to transfer his services to the C.F.-M. Co. as specialist on Skefko bearings, the Engineers' Representative Co. was dissolved.

In June, 1915, Gordon became assistant manager of the machinery department of the Canadian Fairbanks-Morse Co., becoming manager towards the end of the same year. Some twelve months later he went back to his "old love," the Skefko bearing, the Canadian S K F Company, Ltd., with showrooms, as already stated, having been organized to take care of all bearing business offering in Canada, with our "Spoke" as manager. Aside from his heart being well set on the great possibilities of a Canadian market for ball bearings, and to use his own words, "my special weakness for something moving," same being exemplified in his show room window displays, he found time while machinery manager of the Canadian Fairbanks-Morse Co. to design and develop the boring lathe for 6-inch H.E. shell, built by the Reliance Machine Co., Toronto.

Mr. Janes is some politician, to wit, a strong Imperialist; and in religious creed, Church of England. He is a member of the Engineers' Club, Toronto. It will naturally be inferred from the preceding sentences that he is a benedict, the more so in view of his limited club activities. Miss Constance Boon, of Manchester, England, became Mrs. Gordon Janes on August 30, 1913, the marriage ceremony taking place in St. James' Cathedral, Toronto. The family residence is at 21½ Balsam Avenue, Toronto. Walking and cycling have always been Gordon's special recreations, although the opportunities to take advantage of them in Canada are scarcely so ready to hand as were those of the Old Country, the major portion of which he has covered on foot and on the bicycle when touring for pleasure. Since settling in Canada, business activities have led to his becoming more or less familiar with Eastern Canada, as also of a fair slice of the United States.

Our "Spoke" looks for great developments taking place in Canada, following the war, especially in engineering and its allied industries, all of which will, however, call for higher grade skilled help, and, therefore, necessitate an enlargement of the facilities for procuring technical education. Trade and technical papers will in the nature of things become factors of the greatest importance in assisting and consolidating progress towards substantial achievement. "Since starting my engineering career," says Mr. Janes, "I have followed closely the latest developments through these mediums.

EDITORIAL CORRESPONDENCE

Embracing the Further Discussion of Previously Published Articles, Inquiries for General Information, Observations and Suggestions—Your Co-operation is Invited

MACHINISTS' INSTRUCTION COURSE—XVI.

By J. Davies.

IN threading taper-work the tool should be set at right angles to the axis of the work, the same as for parallel work. If the centre is set over by means of the tail-stock it will give an incorrect pitch and also a drunken thread. When the dead centre is set over, the work will be in the position of the dotted lines Figure 56a. The work would have to be set over so that the face would be parallel to the centre lines A.B. Suppose the piece to be 3 in. long, and is to be threaded 10 threads per inch. Since the length of taper, measured on the slope, is greater than the true length of the piece measured parallel with its axis, it will require more than 30 revolutions to carry the tool entirely over the work, consequently there will be more than 30 threads on the piece, and it will not measure up exactly 10 threads per inch.

Taper-work should always be done by the taper attachment. When a thread is cut by setting over the tail-stock, owing to the angularity of the tail of the lathe dog, it does not travel at a uniform speed with the lathe face-plate. The tail of the dog can be observed to slide in and out the notch of the face-plate. When this condition takes place, the thread cannot be a uniform pitch.

Inside Threading

Use the threading gauge for setting up the tool, and see that the shank of the tool is approximately parallel with the work so that the back of the tool will not rub against the first thread before the point gets through the hole. In threading long small holes the biggest trouble to contend with is the spring of the tool. Many lathe hands make the cutting edge of the tool level with the top. This means that the whole of the tool must pass through a circle equal to half the diameter of the hole (see Fig. 57). If the cutting edge of the tool is made to come in the centre

times fastened to the carriage of the lathe and the tool is carried in a parallel bar between the centres of the

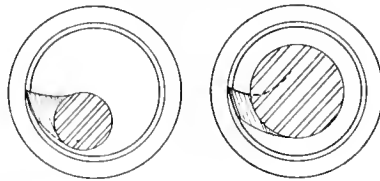

FIG. 57.

lathe. While this method gives excellent results for very long threads such as nuts for rolling mill housing, etc., it is open to the objection that for every cut the tool must be carried back to its starting place by means of a reverse

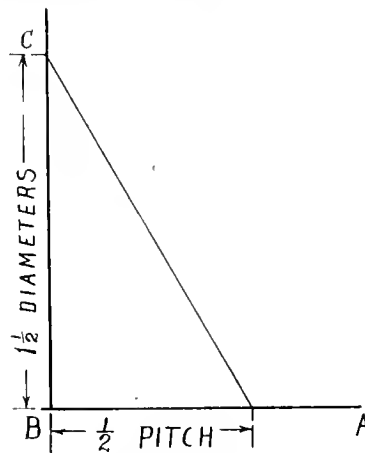

FIG. 58.

belt, or else the tool must be removed from the bar.

Cutting Square Threads

In cutting square threads the shape of the tool is a very important factor. While the tool must have the necessary amount of side clearance depending on pitch of thread, etc., an excessive amount of clearance weakens it and makes it liable to break, neither will the cutting edge stand up to its work so

eral satisfaction in practice:—Draw two lines AB, BC at right angles to each other (Fig. 58). Make BC equal in length to $1\frac{1}{2}$ times the diameter of the screw to be cut. From B mark off a length along BA, equal to half the pitch and draw a diagonal line connecting the two lengths. The diagonal line will give the angle or rake of the tool. Having obtained the angle of side clearance for the tool, mark off a piece of tin for a template, or make a gauge as shown in Fig. 59, which is also useful to the blacksmith in making square thread tools, as in nine cases out of ten, he just guesses the amount of clearance required, with the result that there is a lot of unnecessary filing to do. A tool for finishing square threads should be made very slightly thicker at the root than at the point. This enables the nut to enter more readily, and where the tool is sharpened by grinding the front cutting edge, the sides can be touched up. A tool made this way smooths up the sides and can be ground quite a few times and still retain its original size.

Shaper and Planer Work

The shaper, or the fitter's friend, as it has been sometimes called, and the planer are so nearly akin, that most of the methods and principles are applicable to both; in order, therefore, to avoid any needless repetition, we will consider them together. To enumerate the different types of machines would be a waste of time; a careful examination of the particular machine that one is called upon to operate, will give more useful information than a general description of the different types.

Much of the same work can be done on either shaper or planer, the same methods of securing the work and the same kind of tools being used. The shaper is best adapted for light work and short cuts, or where a cut of a definite length is required, such as cutting a key seat in the end of a shaft, or cutting up to a square shoulder, as the length of stroke of a planer is not positive and cannot be relied upon within an inch. Most shaper work is held in a vise bolted to the shaper table, the vise being usually graduated so that it can be set to any angle.

The first consideration in planer or shaper work is to decide if the work can be done in one setting. Never move or reset a job if it can be avoided. Suppose a blanking die (Fig. 60) is to be shaped so as to leave a margin of steel around the hole about $\frac{1}{2}$ in. wide, this being done to reduce the work of subsequent grindings. This could be done at one setting by swinging the vise around to suit the different angles and taking the finishing cut without moving the tool up or down.

In shaping a square piece of metal,

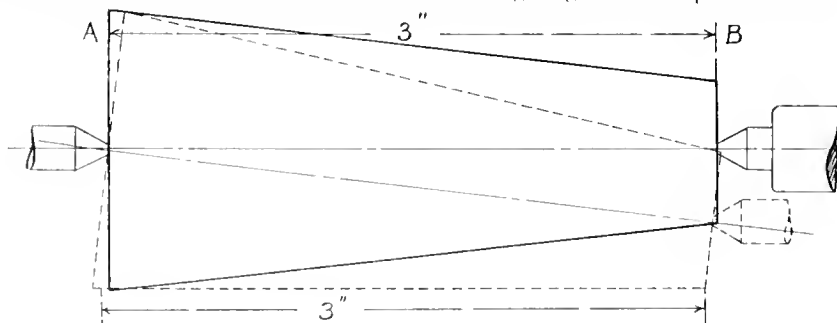

FIG. 56a.

of the shank also as shown in Fig. 57, a much stiffer tool can be used.

In cutting threads in very long sleeves or bushes, the work is some-

long as when correctly designed and made.

The following rule for the side clearance of square thread tools gives gen-

shape two sides first, if possible, then turn your vise around 90 degs. for the other two. It is obvious that if a square

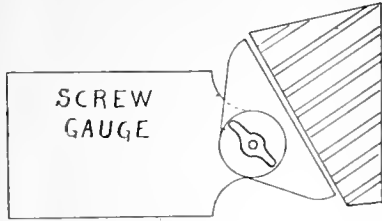

FIG. 59.

block is to be planed square and true all over, this method could not be used, and it would be necessary to reset the job for each surface. In this case, rough the work out all over first, and after one face is finished care must be taken to see that the finished face is held squarely to the jaw of the vise and is at right angles to the surface of the table.

Most vise jaws rise slightly from their seat when tightened up. After tightening up the vise, tap it down with a hammer until it feels solid. If the vise jaws are worn very badly and cannot be relied on, which is usually the case, find the amount of error in your roughing, that is how much it is from being square, then set the surface you have tested by the surface gauge and allow the same amount to be taken off the high side; by using a pair of feelers you can get within two or three thousandths.

If the job projects far enough past the end of the vise, test it with a square from the table. If the vise jaws are in bad shape it may be necessary to put in

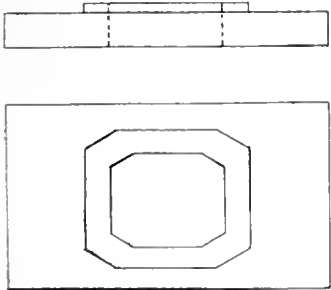

FIG. 60

pieces of tin or other packing to throw the work over into the desired position.

SAVINGS MADE POSSIBLE BY BALL BEARING HANGERS

By C. T. R.

EXHAUSTIVE tests in manufacturing plants have demonstrated that transmission losses due to friction of plain bearings amount to from 20 to 40 per cent. of the total power used in the plant. The purpose of this article is to show how the major portion of this loss can be eliminated by the use of self-aligning ball bearings.

Shafts in cast iron, babbitt or bronze bearings become "set" if the shafting is idle for any length of time. The oil is

pressed out of these bearings, and it is extremely difficult to start the shaft from rest. Again, when the bearings are operating at normal speed, rubbing friction is constantly consuming power at a sacrifice of efficiency. Self-aligning ball bearings are designed to eliminate all these difficulties.

In self-aligning ball bearings the starting friction is no greater than the running friction. This is a very important fact, for, as it is not necessary to provide for heavier starting loads, a much smaller motor may be used. Again, the rolling friction is practically uniform from rest up to very high speed. On this account they start with a minimum effort, and operate at all times with the highest possible efficiency.

When hangers are equipped with self-aligning ball bearings, the selection of a motor for shop drives reduces itself to

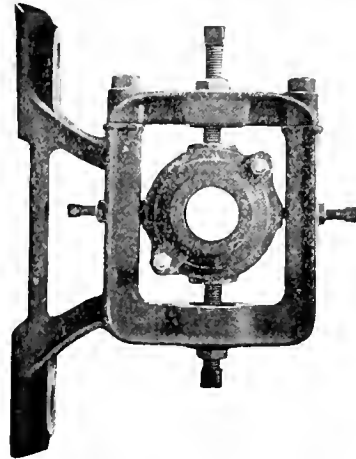

BALL-BEARING POST HANGER.

the problem of providing for normal machine power consumption only, without the necessity of providing for the heavy overload capacity usually required to "start up." For example: if machines in the shop normally require 250 horsepower to drive, and an additional 50 horsepower is consumed by the line shaft in distributing this power, a saving of 50 per cent. of the power required for the line shaft will reduce the total power required by 25 horsepower, i.e., 10 per cent. of the total. With a motor costing approximately \$9 per horsepower, there will be an initial saving of approximately \$225 in the motor cost.

So far, we have considered only the saving in power and the consequent lower first cost of the driving motor. In addition to the saving in power, which alone is a sufficient item, there is also a considerable saving in lubricant. It is necessary to lubricate double row,

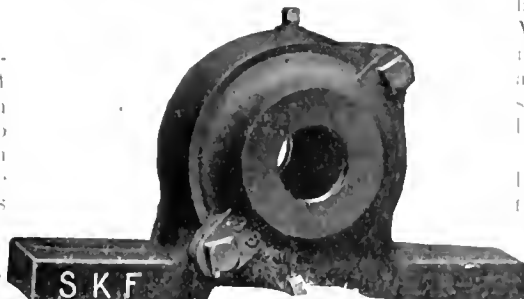

BALL-BEARING PILLOW BLOCK.

self-aligning ball bearings only three or four times a year. The lubricant supplied to each bearing at such times is considerably less than is generally sup-

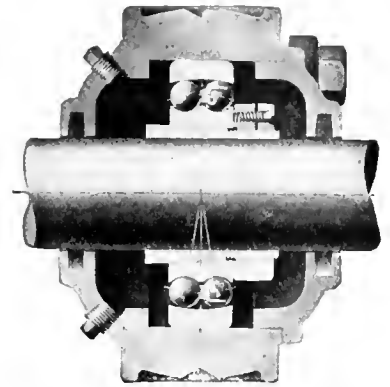

SECTIONAL VIEW, BEARING IN HOUSING.

plied a babbitt bearing several times a month.

This economy in lubrication results from the fact that the liberal lubricant chamber around the bearing is sealed on both sides to insure the retention of the lubricant, as well as to protect the bearings from intrusion of shop dust, grit, etc. The seal is such that the lubricant cannot leak out or creep along the shaft to the pulleys and belts, a feature which preserves the efficiency of the belts and eliminates the uncleanness and annoyance of oil.

In plants where the transmission is exposed to dust, moisture and grit, self-aligning ball bearings will give the best of service. The dust-proof housing is oil tight, excludes foreign matter and



BALL-BEARING DROP HANGER.

holds the lubricant. Cement mills, foundries, woodworking shops and machine shops are some of the places where these bearings can be used to good advantage. Most shafting in plain babbitt bearings is run at speeds from 100 to 400 r.p.m., and if run at higher speeds, it is necessary to lubricate the bearings frequently to avoid hot boxes.

Self-aligning ball bearings may safely be run at double or triple this speed, the size of the pulleys being cut down so that the rim speed is the same as formerly. A considerable saving in the cost of pulleys can thus be effected; or, when operating at increased shaft speed, by

keeping the main line pulleys close to their former diameter (thereby increasing the rim speed), narrower and lighter belts can be used. Working along these lines it is possible to effect savings which will equal the difference in cost between self-aligning ball bearing hangers and plain bearing hangers.

ing works to where I was operating an electric plant. The day came when my neighbor engineer had to put a new drive belt on the engine, which was a 20 in. x 36 in. with a 14-ft. fly-wheel.

The old belt was taken off on Sunday morning and the new one put on.

bed, but did not meet with the desired success. The belt by this time had stretched considerably, and some time during Tuesday morning of the third week it took a notion to flop over and run with its back on the driven pulley. To the surprise of George, when he came to the shop he saw the belt running as nice as could be, right in the centre of the pulley, and with all haste he entered the engine room to ascertain the change, and found it.

"Well, I'll just take it off next Sunday and tighten it up and it will be all right!" But George never had the chance, for the following Thursday the place was burned down.



UP TO the present there has not been sufficient systematic research work done to enable the universal adoption of standard methods of impact testing. The two forms most generally used are the Charpy and the Izod. Both methods employ a small notched specimen, which is tested to destruction. The Izod test specimen is required to be of standard dimensions, i.e., 10 mm. square, and must have a sharp V notch 2 mm. deep, carefully machined at an angle of 45 deg. The fineness to which the V notch is cut influences to an important extent the result of the test. If the bottom of the notch is even slightly round, the specimen will yield high results. From this it is obvious, in the designing of practical parts, that sharp corners should be avoided, as they induce the concentration of stresses in that particular portion of the object. The application of a sudden shock causes a crack to commence at the base of the notch, and fur-



ADAPTER BEARING, DISASSEMBLED AND ASSEMBLED.

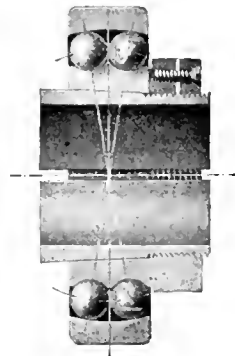

SECTIONAL VIEW, ADAPTER BEARING.

Thus, it is possible to secure the highly efficient ball bearing equipment at the same initial cost as the plain bearing equipment.

Instances are frequently encountered where a manufacturer is using all his available power and is even operating his engines and boilers or motors at a heavy overload. He constantly faces a complete breakdown of his plant. In order to add more machinery it will be necessary for him to invest considerable money in an extension of his power-generating equipment. However, by using self-aligning ball bearings this would be unnecessary in many cases, while in others, the additional requirement would be on a much reduced scale.

We are indebted to the S. K. F. Ball Bearing Co., Toronto, for the accompanying illustrations.

LINE SHAFT TROUBLES

By H. Westwood.

UNDER this heading there appeared an

Monday morning arrived and found the would-be artist at the throttle. When the engine began to turn over, the belt did not run in the centre of the pulley, but far enough over to the right side to rub the wooden partition that had been placed there to prevent anyone falling into the wheel pit.

"Well, she will have to go till Sunday," was the explanation from George. "there is not enough time at night to undo the splice and re-splice it." Each day that week found the belt rubbing the partition harder until it had nearly worn it through, and as each day arrived, George had a new idea as to what might be the trouble.

Blaming the Line Shaft

One thing he was sure of, and that was the drive shaft, which was about 150 feet long, was out of line. Next Sunday arrived and with it a gang of men to line the shaft. Some understood what to do and some didn't; however, the shaft was lined and Sunday night found a tired lot of men and the shaft $4\frac{1}{2}$ inches farther from the engine line on the extreme end. Monday morning came and the engine was started up, but, alas, no improvement in conditions of the belt running in the centre, and to make matters worse, several boxes burned out on the line shaft. A couple of nights that week were spent in fixing up the

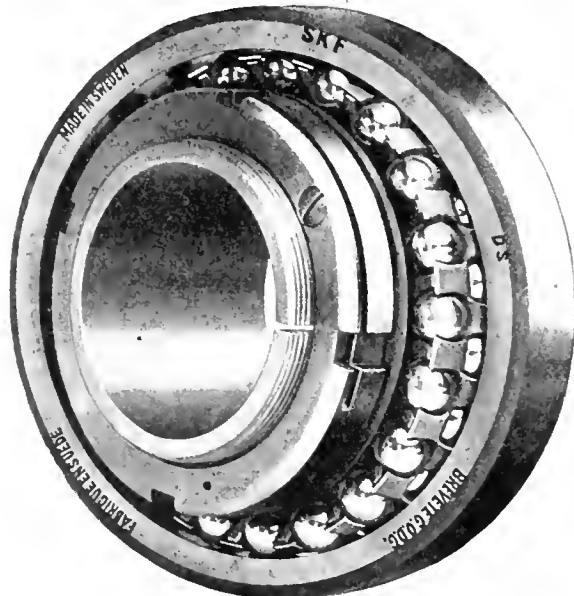

ADAPTER BEARING, DEFLECTED VIEW.

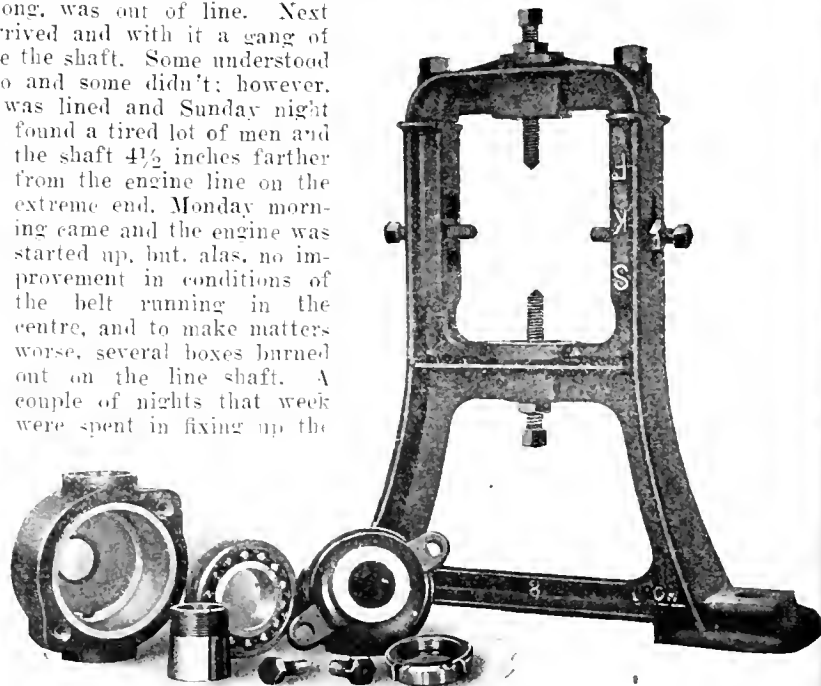

HANGER AND BOX, SHOWING BOX DISASSEMBLED

article in a January issue of your publication. It just serves to remind me of an engineer in a neighbor-

boxes all along the line shaft. The following Sunday an attempt was made to jack the engine around on the

ther fracture is opposed in proportion to the resistance of deformation of the material around the notch.

PROGRESS IN NEW EQUIPMENT

A Record of New and Improved Machinery and Accessories for the Machine, Pattern, Boiler and Blacksmith Shops, Planing Mill, Foundry and Power Plant

UNIVERSAL GAUGE GRINDER

AS a result of industrial developments during the last two years, the making of gauges has assumed considerably increased importance, with corresponding interest in machines used therefor. The machine shown herewith has been

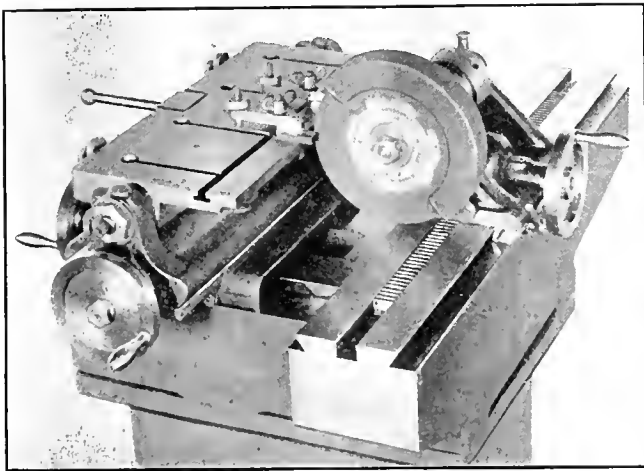

UNIVERSAL GAUGE GRINDER.

designed for manufacturing either snap or master gauges from 4½ in. in depth to 21½ in. in length regardless of steps, but actual use has shown that they can be used for grinding edges on all kinds of special work, while by using inexpensive accessory fixtures, such as tee blocks, etc., their scope of work is largely increased.

The detail design is such that the machine is always ready for work, the flat table with special strap clamps and tee slots reducing the time of setting up to passing over pulley has been overcome by using a floating drive on spindle, the pulley being carried independently on a rear spindle bearing and flexibly connected to a driving sleeve fastened on the spindle.

The spindle is of hardened and ground steel carried in high speed bronze bearings lubricated by centrifugal force from a reservoir in each end, felt oil retainers being provided to prevent leakage. The spindle head has a traverse movement of 17½ in., which can be combined with the 4¼ in. traverse feed of the table. The end of the spindle takes a wheel up to 6 in. x 3½ in. x 1½ in. hole.

Crossfeed is operated by means of hand lever and rack and pinion movement, giving a quick movement for removing excessive stock. Combined with this is an additional movement by fine pitch screw and handwheel for extreme accuracy and fine finish. Telescopic dust guards are fitted to the carriage slides.

The table is of ample size to take all classes of snap or master gauges, and has a perfectly flat working surface on

which the work is fastened. Permanent strap clamps and suitable tee slots facilitate the fastening of the work. Duplication of the work is accomplished by a setting gauge which has an included tilt of 10 deg., up and down enabling the grinding of thick or thin gauges, while still keeping the centre of the work on a line with the centre of the wheel. The table traverse can be controlled to .0005 in.

The arrangement of the machine enables the operator to sit down when manipulating same and watch the work to best of advantage.

The builders of this machine are the Steel Products Engineering Co., Springfield, O., who supply it complete with self-oiling countershaft and 6 in. emery wheel. The size of table is 6¾ in. x 13 in. feed of table 3 in., table traverse,

4¼ in., spindle head traverse, 17½ in., floor space 21 ½ in. x 30 in.



RELIEVING ATTACHMENT FOR ENGINE LATHE

THE accompanying cut shows a relieving

attachment which has been designed by the Cincinnati Iron & Steel Co., Cincinnati, O., installed on a lathe of their manufacture. Every effort has been made to provide a satisfactory device combining simplicity of design with efficiency of operation.

The attachment is driven by a gear on the outer end of the lathe spindle, which replaces the spindle bush, and does not necessitate any change in the spindle itself. This gear meshes with an idler, which in turn drives a set of change gears on a swinging quadrant mounted on the drive box. This box is bolted to the front of the headstock, and contains the gears which drive the sliding shaft.

A supporting bracket for the sliding shaft is mounted on the adjacent side of the carriage, thus permitting a wide latitude in the position of the carriage when relieving. A telescopic shaft with two universal joints connects the end of the sliding shaft with the cam shaft, giving correct compensation for slide and swivel adjustments. The swivel can be turned to an angle of 30 deg., and all bottom slide and top slide adjustments when connected with the relieving attachment are made exactly as with a regular lathe. The taper attachment can also be used in conjunction with the relieving attachment.

One single and one double impulse cam are provided with each attachment, the cam shaft, which runs in bronze bearings, being easily removed for changing cams. The cams operate against

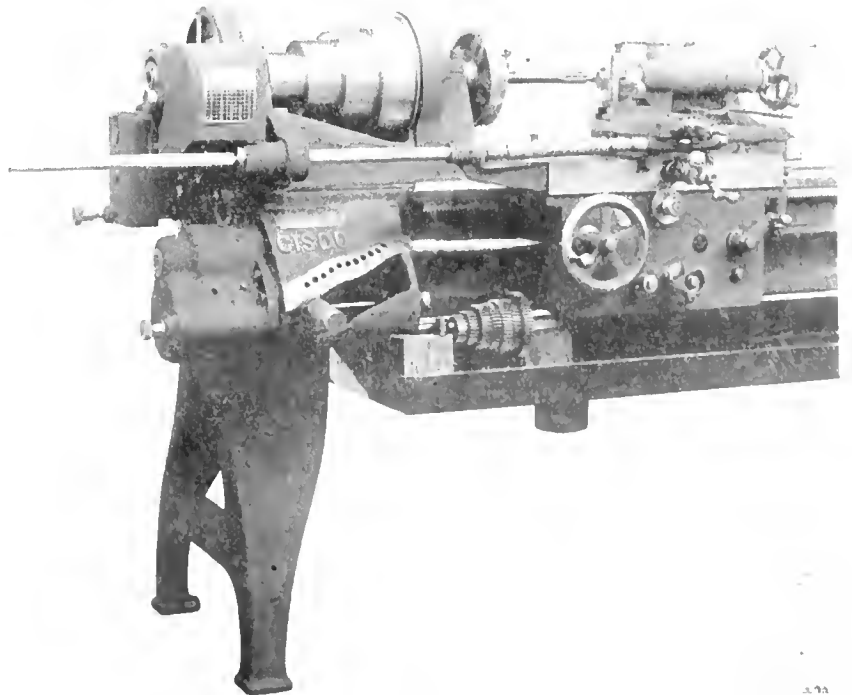

RELIEVING ATTACHMENT FOR ENGINE LATHE.

a hardened steel roller held in a hardened steel slide, which is connected to the top slide screw, and has a spring rod with two adjusting nuts for governing the amount of throw or relief; or, it can be set to hold the slide and roller away from the cam when the compound rest is required for regular work.

Six change gears are provided, which give thirteen numbers of flutes from 1 to 8 inclusive, and 10, 12, 14, 16 and 20.



SHRAPNEL SOCKET MACHINE

THE machining of brass sockets for shrapnel offered good opportunity for the application of single purpose machines, and the facing and threading machine illustrated herewith is one which has proved capable of maintaining an average production of slightly over 700 pieces per 10 hour day. The outside operation, as it is termed, is performed after the inside work is done, it being possible to place the work and remove it without stopping the spindle. The tool, which is of the formed type is then fed forward by the lever, cutting, facing and forming the socket by the one movement, which leaves the work ready for threading.

The chaser bracket which swings backward when not in use, is now dropped into place and is traveled across the work by a threaded drum. This machine is built by the Canadian Chadwick Metal Co., Hamilton, Ont.



20 IN. CRANK SHRAPNEL

PRESENT day demands have been carefully studied by the builders of the 20 in. crank shaper shown in the accompanying engraving, ample rigidity, power, and convenience of operation having been combined with simplicity,

reliability and accuracy of construction.

The frame and base are cast in one piece, and an oil pan inside the base catches all drip from the bearings. The hub carrying the bull gear is cast solid with the frame, and is liberally proportioned. Both the crank pin and the crank pin block are hardened and ground, the block being bushed with a cast iron sleeve for crank pin bearing.

The ram has a bearing in the frame of $11\frac{1}{4}$ in. x 34 in., and is amply braced to carry heavy cuts. It can be set in any position while in motion or at rest, an index showing the length of stroke.

Cross feed mechanism is operated entirely at end of cross rail, in all its adjustments. The feed takes place on reverse stroke only, the amount being indicated on a dial. A ball lever on top of feed gear casing starts, stops, or reverses the feed while in motion. The tool head swivel is securely bound to the head of ram by a single screw, and micrometer dial is provided for indicating feed in thousandths.

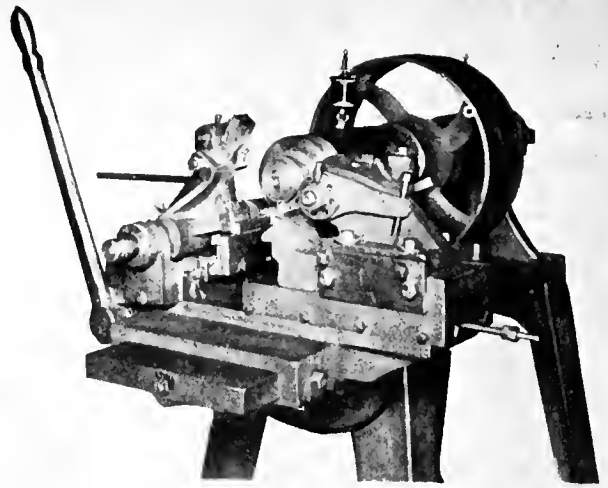

FACING AND THREADING MACHINE FOR 18-PDR SHRAPNEL BRASS SOCKETS.

An outboard bearing which acts as a belt guard is provided for the shaft of the four step driving cone. An expanding friction clutch drive of large diameter, which engages with the cone, is operated by a long horizontal lever at side of frame. Eight speeds are obtainable through the medium of back gearing.

An adjustable bottom support under the table slides on a channel shaped track which protects it from chips and dirt. A graduated base on the vise is held down by four bolts and acts as a clamp which holds the vise solid to table.

The actual stroke is $20\frac{3}{4}$ in.; horizon-

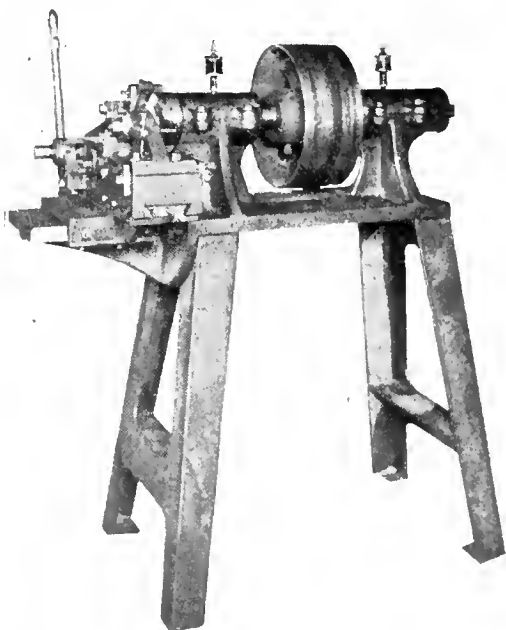

FACING AND THREADING MACHINE FOR 18-PDR SHRAPNEL BRASS SOCKETS.

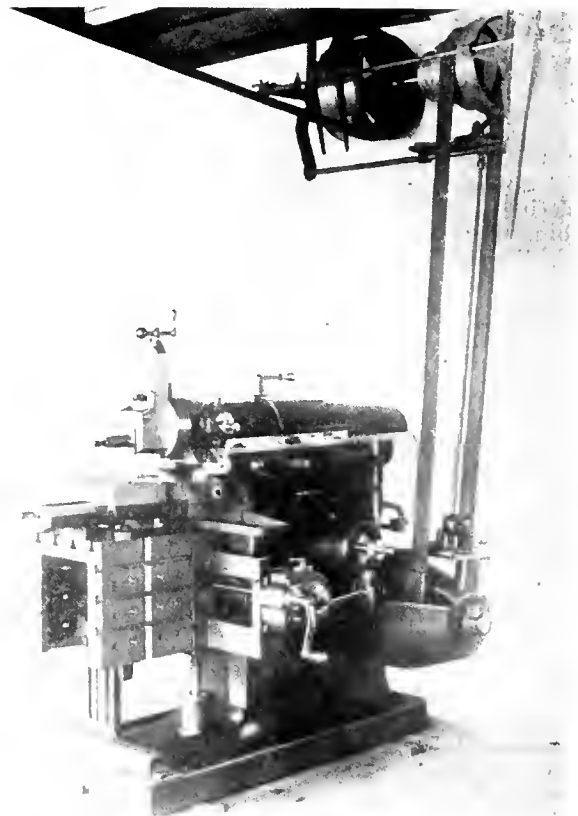

20-INCH CRANK SHAPER SHOWING ALSO BELT SHIFTING MECHANISM.

tal travel of table 24½ in.; vertical ditto 15 in.; top of table, 16 in. x 20 in.; power cross feed, .008 in. to .200 in.; ram. strokes per min. 8-115; net weight, 4,100 lbs. The Hendey Machine Co., Torrington, Conn., are the builders of this machine.



CORES, THEIR CONSTITUENTS AND COMPARATIVE COSTS

IN a paper read before the Scottish Branch of the British Foundrymen's Association on January 13, Arthur Naylor read a Paper on "Cores, and their Material Constituent, and Comparative Costs." Mr. Naylor remarked that it is now considered an established practice to separate coremaking from the trade of moulding, and very few foundries are now to be found where there is not a core-making department. This is not only a more economical arrangement but it is an arrangement by which greater efficiency is obtained. The question of materials used in core-making varies to some extent with local conditions. The price charged for carriage of new sand has also an important bearing upon the subject, in determining the proportion of new and old sand to be used.

Oil-Bonded Cores

With inexperienced foundrymen, the question of comparative costs, with regard to ordinary sand cores and oil-bonded cores is a debatable matter. At glance it seems a costly procedure to use oil at say, \$8.50 to \$10 per 100 lbs. compared with using ordinary sand. However, as a result of actual practice there is no doubt that the use of oil-bonded cores is more economical. For ordinary work, sea sand bonded with linsed oil serves admirably for cores. It is not always advantageous to use oil-bonded cores in every instance, but for work such as steam-chest cores, cylinder-port cores, cores for water-jacketed cylinders, compressors, etc., and in all cases where the extraction of the core after casting presents a difficulty, nothing could be more suitable or more economical than oil-bonded cores.

The amount saved in dressing such castings more than pays for the oil also any extra work involved in the production of the cores. In the majority of cases an oil-bonded core does not take any longer to produce than a similar core made in ordinary sand; it has also these further advantages, that fewer core irons are required and less venting is necessary than with similar cores in ordinary sand. The question of drying is slight against the oil-bonded core, but a little experience soon overcomes any difficulty met with in this respect. The temperature of the stove for drying such cores should not exceed 500 deg. Fah. Oil bonded cores are much easier to handle and less liable to break when placing in position, and they may be left any length of time in the mould before casting as they do not absorb moisture.

An example from personal experience

was given to show the comparative costs of the two systems of producing cores. That selected was the cores of a water-cooled gas-engine cylinder. At first these cores were produced in the ordinary way by grinding a quantity of loam taken from a used mould; this powder was again dried in the stove and then milled with an equal proportion of new sand, and a liberal proportion of horse-dung and clay-water. The production of these cores, including the necessary core irons, took from four to five days, and after the castings were made it took 1½ to 2 days to remove the cores. When the system of oil-bonded cores was adopted the cores were extracted from the castings in 15 minutes. The cost of each system is shown in the following tables:

Ordinary Sand Cores

Sand and mixing.....	00.75
Core Irons.....	3.75
Making Cores.....	11.00
Dressing and blackwashing cores .	2.50
Dressing castings.....	5.00
Total.....	\$23.00

Oil Bonded Cores

Sand and mixing.....	.75
2 gallons oil at 4s. per gallon....	2.00
Making cores.....	7.50
Dressing and blackwashing cores..	2.50
Dressing casting.....	1.75
Total....	\$14.50

The core irons for oil-bonded cores, where these are necessary, may be wrought iron, and re-used from time to time; the ends of these irons should be arranged to project into the print of the core, and when this precaution is observed the irons can be easily removed from the casting. Any vertical recesses left by the removal of loose pieces in the core-box should be filled with dry or wet parting sand, and removed after the core is dried. Should these recesses be in a horizontal position the spaces must be formed by rubbing down a small piece of dried core to the shape of the recess; this should be covered with paper and rammed up with the core, the paper forming a parting substance to facilitate the withdrawal of the small core after the main core has been dried.

If any part of the main core is to come into contact with the plate for supporting the core while drying, the part coming in contact should be separated by a piece of paper, otherwise it may adhere to the plate. Should any sharp edges be exposed to the heat they are liable to burn. This may be avoided by spreading a little oil from an ordinary oil-can over the exposed part. Oil-bonded cores contract about one-eighth of an inch per foot, and provision for this has to be made in the core-box.

Scabbing is practically an unknown factor with oil-bonded cores, provided a clean open silica sand is used. The boxes in which the cores are made should be well oiled to prevent the sand adhering to the sides of the box. We are indebted

to the Foundry Trade Journal for the foregoing synopsis of the Paper.



EXPORTING ZINC FROM JAPAN

THE British Vice-Consul at Osaka, Japan, G. White reports that exports of refined zinc from Kobe and Osaka in 1915 amounted to 3,700 tons, valued at £311,000. Prior to the war, Japanese refined zinc had to face severe competition in Japan itself from imports and was unable to pay its way. Everything changed with the outbreak of the war and the refineries, being free from competition were only concerned how most rapidly to increase their output to meet home orders and orders from abroad. The output, which was estimated at 5,000 tons in 1914, amounted to from 16,000 to 18,000 tons in 1915, and is expected to reach 25,000 tons or more in 1916.

From exporting concentrates Japan has come to importing same, and in 1915 supplies were imported from China and Siberia. Attempts were also made to obtain concentrates from Australia. Two companies were responsible for the greater part of the output in 1915, although small concerns between them refined some 2,000 tons of zinc. Hitherto, there has been only one factory using electrolytic methods, but the remarkable difference in price between the purest quality and the lower grades, and the difficulty of producing the former by the "dry" method, has led to the erection of two other electric furnaces, the total output by this method being about 700 tons per month.



CANADIAN FISHERIES INCREASE

THE total value of Canadian fisheries during the last fiscal year, according to the annual report of the Fisheries Department, was slightly less than \$36,000,000, an increase of four and a half millions, as compared with the previous year. It is anticipated that if the new arrangements with the War Office for the use of Canadian fish is a success, these figures will be greatly increased in the future.

Of the increased value over three million dollars is attributable to a bigger catch in British Columbia waters. The Rivers Inlet, Skeena River and Naas River districts contributed over two millions. The increase due to an increased pack of salmon and higher prices.

A substantial increase of \$1,436,000 is recorded in Nova Scotia fisheries. The value of New Brunswick catch fell off \$300,000. Prince Edward Island by \$300,000 and Manitoba by \$106,497.

The value of Quebec fisheries increased by \$152,421. Salmon with a production of upwards of eleven million dollars, continues to hold first place as the most valuable of Canadian fish.

The MacLean Publishing Company LIMITED

(ESTABLISHED 1888)

JOHN BAYNE MACLEAN - - - - - President
H. T. HUNTER - - - - - Vice-President
H. V. TYRRELL - - - - - General Manager

PUBLISHERS OF

CANADIAN MACHINERY AND MANUFACTURING NEWS

A weekly newspaper devoted to the machinery and manufacturing interests.

PETER BAIN, M.E., Editor. B. G. NEWTON, Manager.

Associate Editors.

A. G. WEBSTER, J. M. WILSON, J. H. RODGERS.

Office of Publication, 143-153 University Avenue, Toronto, Ont.

Vol. XVII. MARCH 22, 1917 No 12.

CANADIAN STEEL INDUSTRY OUTLOOK

THE uncertainty of the meantime international situation, as regards the entrance of the United States into the war arena, is having no material effect on the production activities of steel mills, whether in Canada or the United States. Rather the reverse, we might say, and, taken in conjunction with the high prices now ruling for steel products, the every-day more near approach to relief from transportation disabilities, and the very comprehensive and extensive shipbuilding programme—wood and steel, now initiated in Canada, there is ground for little else than well-founded optimism as regards the metal-working plant outlook—munitions and otherwise. Not only is progress being made in the development of the shipbuilding and marine engineering plans as outlined here a week ago, but many of the disabilities under which our steel and other engineering industries have been laboring are being gradually removed. As an evidence of this in but one direction, the Steel Company of Canada, Hamilton, Ont., have blown in their No. 2 furnace which has been standing idle for some time, and are now operating their No. 1 furnace at full blast.

Production of steel during February was much curtailed, and while that for the present month may possibly fall short of expectations, there is nevertheless considerable evidence available to indicate that net earnings of our various producers for 1917 will equal, if not surpass, those of 1916. Not the least satisfactory feature of the annual statements of our steel corporations, so far available, is the conservative distribution of the accrued profits from the past year's operations or more. The motive prompting the action indicated may be one or other of not a few that readily occur to students of the industrial situation in Canada, present and prospective. However, in view of the fact that steel shipbuilding is about to assume large proportions within our borders, and is destined to assume a permanent value hitherto unapproached, it may readily

be assumed that the retention of large surplus earnings belongs to a policy which will in the near future find practical expression in the installation of plate mills—ship and boiler plate, by more than one of our principal steel corporations. Lack of steel for ship construction is probably more acute than the lack of shipyards on our lake and ocean shores. It is therefore more contributory to the non-carrying out of the shipbuilding programme now being launched, with that degree of dispatch so much desired, because so clearly urgent.



CANADA'S DIRECTOR OF SHIPBUILDING

IN THE appointment of J. W. Noreross, vice-president and general manager of the Canada Steamship Lines, as director of shipbuilding in Canada, we find evidence of an effort to appoint for the management of public affairs, men who have shown through their success in business and industry their practical ability and executive capacity to handle big projects—to do things and to get things done. Mr. Noreross, co-operating with the Imperial Munitions Board, is to organize the shipbuilding facilities of Canada in the interests of the British mercantile marine. A better man could not perhaps have been selected. He knows the sailing and construction of a vessel, and has proven that he can plan, finance and successfully carry out large undertakings. A few years ago a lake captain, to-day the recognized genius of the Canada Steamship Lines and a prominent authority upon water transportation in Canada, Mr. Noreross is the type of executive required in the handling of our national business generally. It is to be hoped that the example which the British authorities, through the Imperial Munitions Board, have shown in picking the man that the position demanded and setting aside all other considerations will be followed by the powers that be at Ottawa in other directions. There are many big business men in Canada who to-day should be filling Dominion portfolios, not because of their political influence or public popularity, but because the country's affairs require their services for efficient administration.



TRAINING SCHOOLS FOR APPRENTICES.

VERY few of our firms are in a position to operate individual training schools for apprentices, and the feasibility of co-operation among employers is suggested thus by a writer in a contemporary: "Why not get together within the industry and organize what will be frankly trade schools, owned and operated by the manufacturers through the medium of stock companies where boys shall be offered opportunities that they cannot afford to pass by?" This remark is quoted without any disparagement of the work being done in technical schools; attendance at such institutions does not always mean that the student will join the ranks of skilled mechanics—frequently he is induced to leave and enter the employ of some firm which fails to realize that it is to his own and the industry's ultimate loss. The equipment and instruction given in a jointly owned school could be of a varied yet thorough nature which while in line with the general requirements of the student's employers would insure his ability to tackle any work not absolutely specialized.

Out of the large number of present operators, drawn from many sources, quite a few bright individuals will certainly be available for and ready to take advantage of all trade school instruction offering, all of whom might well form the nucleus of a later addition to the ranks of trained machinists, an asset of considerable value to the trade, employers, and the nation.

INDUSTRIAL NOTABILITIES

CHARLES FREDERICK WHEATON, general manager, the Dodge Manufacturing Co., Ltd.—a \$1,500,000 corporation producing power transmission machinery, elevating and conveying machinery, Osler and Pelham streets, Toronto, was born at Brantford, Ont., October 17, 1859, son of James Franklin and Margaret Wheaton. He was educated in Public Schools, Toronto, and started his business career as office boy with Henry L. Smythe, Montreal in 1870. From 1872 until 1877 he was employed by Russell & McLean, wholesale milliners, Montreal. From 1878 until 1883, he was associated with Thomas May & Co. and Paterson Bros., Toronto, in the latter year becoming bookkeeper to Samuel May. Two years later, this gentleman



CHARLES FREDERICK WHEATON

purchased the patents covering the Dodge split wood pulley, Mr. Wheaton being placed in charge of the new department. In due course, the Dodge Manufacturing Co. was incorporated, developing under Mr. Wheaton's management until its output now reaches a value of \$1,000,000 per annum.

Mr. Wheaton married Ida Gertrude Holmes, daughter of Robert Holmes, Toronto, their family consisting of one son and three daughters. His Clubs are the National, Albany, R.C.Y.C., and Canada Bowling, Toronto; and Engineers, Montreal. He served with F Company, Queen's Own Rifles from 1880 to 1883. His recreations are motoring, bowling and billiards. In politics he is Conservative and, in religion Methodist. The family residence is 122 Bedford Road, Toronto, Ont.

Photo courtesy International Press.

SELECTED MARKET QUOTATIONS

Being a record of prices current on raw and finished material entering into the manufacture of mechanical and general engineering products.

PIG IRON.

Grey forge, Pittsburgh...	83-95
Lake Superior, charcoal, Chicago	36 75
Standard low phos., Phila-	
delphia	70 00
Bessemer, Pittsburgh	36 95
Basic, Valley furnace	32 00
Montreal Toronto	
Middlesboro, No. 3	
Cleveland, No. 3	
Clarence, No. 3	
Hamilton	43 00
Victoria	

FINISHED IRON AND STEEL.

Per lb. to Large Buyers	Cents
Iron bars, base, Toronto	4 25
Steel bars, base, Toronto	4 25
Steel bars, 2 in. to 4 in. base	5 25
Steel bars, 4 in. and larger base	6 50
Iron bars, base, Montreal	4 25
Steel bars, base, Montreal	4 50
Reinforcing bars, base	4 05
Bessemer rails, heavy, at mill	38 00
Steel bars, Pittsburgh	3 75
Tank plates, Pittsburgh	5 25
Beams and angles, Pittsburgh	3 40
Steel hoops, Pittsburgh	4 00
F.O.B. Toronto Warehouse.	
Steel bars, base	4 50
Small shapes	5 00
F.O.B. Chicago Warehouse	
Steel bars	4 00
Bars, 2 in. and up	4 40
Structural shapes	4 25
Plates	5 50

FREIGHT RATES.

Pittsburgh to Following Points	Per 100 lbs.	C.L.	L.C.L.
Montreal	23.1	31.5	
St. John, N.B.	35.1	45.5	
Halifax	35.1	45.5	
Toronto	18.9	22.1	
Quehlf	18.9	22.1	
London	18.9	22.1	
Windsor	18.9	22.1	
Winnipeg	64.9	85.1	

METALS.

Montreal Toronto	
Lake copper	\$43 00 \$40 00
Electro copper	43 00 40 00
Castings, copper	40 00 39 00
Tin	53 00 56 00
Spelter	15 00 14 00
Lead	12 00 12 50
Antimony	34 00 35 00
Aluminum	70 00 68 00

BOILER PLATES.

Montreal Toronto	
Plates, 1/4 to 1/2	\$6 50 \$6 50
Heads	6 85 6 85
Tank plates, 2-16 in.	6 10 6 10

WROUGHT PIPE.

In effect March 5, 1917.		
Per 100 feet— Black Galv.		
Buttweld.		
1/4 in.	\$ 4 50	\$ 6 00
1/2 in.	3 78	5 91
3/4 in.	3 78	5 91
1 in.	4 93	6 50
1 1/4 in.	6 10	8 22
1 1/2 in.	9 01	12 16
2 in.	12 19	16 45
2 1/2 in.	14 58	19 06
3 in.	19 61	26 46
3 1/2 in.	31 01	41 83
4 in.	40 53	54 70
4 1/2 in.	56 00	67 62
5 in.	59 95	80 12
Lapweld.		
2 in.	22 57	29 05
3 in.	33 92	44 17
4 in.	44 37	57 76

3 1/2 in.	55 20	72 22
4 in.	65 40	85 57
4 1/2 in.	76 20	99 70
5 in.	88 80	116 20
6 in.	115 20	150 70
7 in.	152 30	196 40
8 L. in.	160 00	206 30
8 in.	184 30	237 60
9 in.	220 80	284 60
10 L. in.	204 80	264 00
10 in.	263 70	339 90

Prices Ontario, Quebec and Maritime Provinces.

WROUGHT NIPPLES.

4" and under, 60%.	
4 1/2" and larger, 55%.	
4" and under, running thread, 40%.	
Standard couplings, 4" and under, 50%.	
4 1/2" and larger, 30%.	

OLD MATERIAL.

Dealers' Buying prices.		
Montreal Toronto		
Copper, light	\$24 00	\$24 00
Copper, crucible	28 00	28 00
Copper, heavy	28 00	27 50
Copper wire	28 00	28 00
No. 1 machine composition	23 00	22 00
No. 1 composition turnings	19 00	20 00
New Brass clippings	18 50	18 00
No. 1 brass turnings	15 50	17 00
Steel, low phos.	14 00	18 00
Heavy Melting steel	13 00	16 00
No. 1 machine cast iron	21 00	18 00
Steel turnings	9 00	9 00
Boiler plate	12 00	10 50
Rails	14 75	15 00
Axles, wrought iron	19 00	24 60
Tires, steel	12 00	12 00
Rails	14 75	18 00
Shafting	21 00	20 00
Malleable scrap	10 25	11 00
Pipe, wrought	10 50	9 00
Stove plate	14 60	13 00
Heavy lead	8 00	10 00
Tea lead	6 00	6 50
Scrap zinc	8 50	10 00
Aluminum	36 00	35 00

BOLTS, NUTS AND SCREWS.

Per Cent.	
Coach and lag screws	55
Stove bolts	55
Plate washers	10
Machine bolts, 7-16 and over	10
Machine bolts, 3/4 and less.	20
Blank bolts	10
Bolt ends	10
Machine screws, fl. and rd. hd., steel	27 1/2
Machine screws, o. and fl. hd., steel	10
Machine screws, fl. and rd. hd., brass	add 20
Machine screws, o. and fl. hd., brass	add 25
Nuts, square, up to 1 in., net list.	
Nuts, hex., up to 1 in., net list.	
Copper rivets and burrs. list plus	20
Burrs only list plus	50
Iron rivets and burrs.	27 1/2
Boiler rivets, base 3/4-in. and larger	\$6.35
Structural rivets, as above	6.25
Wood screws, flat, bright	.75
Wood screws, O. & R., bright	.70
Wood screws, flat, brass	.42 1/2
Wood screws, O. & R., brass	.40
Wood Screws, flat, bronze	.35
Wood screws, O. & R., bronze	.22 1/2

MILLED PRODUCTS.

Percent.	
Set screws	35
Sq. & Hex. Head Cap Screws	30
Rd. & Fil Head Cap Screws	10
Flat 7/8 Int. Hd. Cap Screws plus	10
Fin. & Semi-fin. nuts up to 1 in.	25
Fin. and semi-fin. nuts, over 1 in., up to 1 1/2 in.	30
Fin. and semi-fin. nuts, over 1 1/2 in., up to 2 in.	10
Studs	20
Taper pins	40
Coupling bolts, plus	10
Planer head bolts, without fillet	10
Planer head bolts, with fillet	10 and 10
Planer head bolt nuts, same as finished nuts.	
Planer bolt washers	net
Hollow set screws	list plus 20
Collar screws	list plus 30
Thumb screws	20
Thumb nuts	65
Patch bolts	add 40, 10
Cold pressed nuts to 1 1/2 in.	add \$4.50
Cold pressed nuts over 1 1/2 in.	add \$7.00

BILLETS.

Per gross ton	
Bessemer billets	\$65 00
Open-hearth billets	65 00
O.H. sheet bars	65 00
Forging billets	90 00
Wire rods	80 00

F.o.b. Pittsburgh.

NAILS AND SPIKES.

Wire nails	5 00	4 95
Cut nails	4 70	4 70
Miscellaneous wire nails	65%	
Pressed spikes, 5/8 diam., 100 lbs.		4 60

MISCELLANEOUS.

Solder, strictly	0 33
Solder, guaranteed	0 35
Rabbit metals	13 to 60
Soldering coppers, lb.	0 53
Putty, 100-lb. drums	3 85
White lead, pure, cwt.	14 25
Red dry lead, 100-lb. kegs. per cwt.	13 87
Glue, French medal, lb.	0 25
Tarred slaters' paper, roll	0 95
Gasoline, per gal., bulk.	0 20 1/2
Benzine, per gal., bulk.	0 29 1/2
Pure turpentine, single bbls., gal.	0 75
Linseed oil, raw, single bbls.	1 40
Linseed oil, boiled, single bbls.	1 43
Plaster of Paris, per bbl.	2 50
Plumbers' oakum, per cwt.	8 00
Packing, square braided.	0 27
Packing, No. 1 Italian	0 32
Packing, No. 2 Italian	0 25
Lead wool, per lb.	0 15
Pure Manila rope	0 29 1/2
Transmission rope, Manila	0 27 1/2
Drilling cables, Manila	0 22 1/2

POLISHED DRILL ROD.

Discount off list, Montreal and Toronto 25%

CARBON DRILLS AND REAMERS.

Per Cent.	
S.S. drills, wire sizes up to 52	40
S.S. drills, wire sizes, No. 53 to 80	25
Standard drills to 1 1/2 in.	15
Standard drills, over 1 1/2 in.	40
3-fluted drills, plus	10
Jobbers' and letter sizes.	40
Bit stock	40
Ratchet drills	15
S.S. drills for wood	40
Wood boring brace drills	25
Electricians' bits	30
Sockets	30

Sleeves	40
Taper pin reamers	20
Drills and countersinks	list plus 30
Bridge reamers	45
Centre reamers	10
Chucking reamers	10
Hand reamers	15

COLD ROLLED SHAFTING.

At mill	list plus 40%
At warehouse	list plus 50%

Discounts off new list. Warehouse price at Montreal and Toronto.

IRON PIPE FITTINGS.

Canadian malleable, A, add 10%; B and C, 10%; cast iron, 35%; standard bushings, 50%; beaders, 60; flanged unions, 40; malleable bushings, 50; nipples, 55; malleable lipped unions, 50.	
--	--

SHEETS.

Montreal Toronto		
Sheets, Black, No. 28, 5/8	\$5 50	\$6 15
Sheets, Black, No. 10, 6 00		6 00
Canada plates, dull, 52 sheets	5 75	5 75
Canada plates, all bright	7 50	7 50
Apollo brand, 10% oz. galvanized	7 25	7 25
Queen's Head, 28 B. W.G.	7 75	7 75
Fleur-de-Lis, 28 B.W.		
G.	7 45	7 35
Gorbal's Best, No. 28	8 25	7 50
Colborne Crown, No. 28	8 00	6 75
Premier, No. 28 U.S.	7 75	7 70
Premier, 10 3/4 oz.	8 00	8 00

PROOF COIL CHAIN.

1/4 in.	\$9 45
5-16 in.	9 10
3/8 in.	8 35
7-16 in.	7 15
1/2 in.	6 95
5-16 in.	6 95
3/8 in.	6 80
1/2 in.	6 70
3/4 in.	6 55
1 inch	6 40

Above quotations are per cwt.

ELECTRIC WELD COIL CHAIN B.B.

1/4 in.	\$15 50
3-16 in.	11 70
1/2 in.	8 40
3/4 in.	7 40
5-16 in.	6 35
3/8 in.	6 35
7-16 in.	6 35
Packing, square braided.	6 35
5/8 in.	6 35
3/4 in.	6 35

Prices per 100 lbs.

FILES AND RASPS.

Per Cent.	
Great Western, American	60
Kearney & Foot, Arcade	60
J. Barton Smith, Eagle	60
McClelland, Globe	60
Whitman & Barnes	60
Black Diamond	50
Delta Files	47 1/2
Nicholson	50
Globe	57 1/2
Vulcan	57 1/2
Disston	60

COAL AND COKE.

Solvay Foundry Coke	
Connellsville Foundry Coke	
Yough Steam Lump Coal	8 50
Pittsburgh Steam Lump Coal	8 50
Best Slack	9 00

Net ton f.o.b. Toronto

BOILER TUBES.

Size.	Seamless	Lap-welded
1 in.	\$22 00
1 1/4 in.	25 00
1 1/2 in.	29 00	24 00
1 3/4 in.	30 00	22 50
2 in.	33 00	23 00
2 1/2 in.	35 50	29 50
3 in.	46 00	34 50
3 1/2 in.	41 00
3 1/2 in.	53 00	44 00
4 in.	65 00	55 00

Prices per 100 feet, Montreal and Toronto.

OILS AND COMPOUNDS.

Castor oil, per lb.	25
Royalite, per gal., bulk.	15
Machine oil, per gal.	25 1/2
Black oil, per gal.	12 1/2
Cylinder oil, Capital.	45 1/2
Cylinder oil, Acme.	36 1/2
Standard cutting compound, per lb.	0.6
Lard oil, per gal.	1 45
Union thread cutting oil antiseptic.	68
Acme cutting oil, antiseptic.	37 1/2
Imperial quenching oil.	39 1/2
Petroleum fuel oil.	12 1/2

BELTING—NO. 1 OAK TANNED.

Extra heavy, single and double.	30-5%
Standard.	40%
Cut leather lacing, No. 1.	1 50
Leather in sides.	1 35

TAPES.

Chesterman Metallic, 50 ft.	\$2 00
Lufkin Metallic, C03, 50 ft.	2 00
Admiral Steel Tape, 50 ft.	2 75
Admiral Steel Tape, 100 ft.	4 45
Major Jun. Steel Tape, 50 ft.	3 50
Rival Steel Tape, 50 ft.	2 75
Rival Steel Tape, 100 ft.	4 45
Reliable Jun. Steel Tape, 50 ft.	3 50

WASTE.

White	Cents per lb.
XXX Extra	20
Peerless	20
Grand	19
Superior	19
N L C R	18
Atlas	18
X Empire	18
Ideal	17
X press	16

COLORED.

Lion	14 1/2
Standard	13
No. 1	13
Poplar	11 3/4
Keen	10 1/2

WOOL PACKING.

Arrow	25
Axle	20
Anvil	15
Anchor	11

WASHED WIPERS.

Select White	12
Mixed colored	10
Dark colored	09

This list subject to trade discount for quantity.

RUBBER BELTING.

Standard	50%
Best grades	30%

ANODES.

Nickel	.50 to .54
Cobalt	1.75 to 2.00
Copper	.44 to .46
Tin	.49 to .56
Zinc	.23 to .25

Prices Per Lb.

COPPER SHEETS.

Montreal Toronto	
Bars, 1/2 to 2 in.	55 (6) 53 00
Plain sheets, 14 oz.	55 00 53 50
14x28 in., 14x60 in.	55 00 53 50
Copper sheet, tinned, 14x60, 14 oz.	60 00 54 25
Copper sheet, plain-ished, 14x60 base.	64 00 60 00
Braziers', in sheets, 6x4 base	55 00 52 00

BRASS.

Brass rods, base 1/2 in to 1 in rd.	0 55
Brass sheets, 8 in. wide, 20 oz.	0 60
Brass tubing, seamless.	0 57
Copper tubing, seamless.	0 58

PLATING SUPPLIES.

Polishing wheels, felt.	2 10
Polishing wheels, bull-neck	1 35
Emery in kegs, American	06
Pumice, ground	04
Emery glue	15 to 20
Tripoli composition	04 to 06
Crocus composition	07 to 08
Emery composition	08 to 10
Rouge, silver	35 to 50
Rouge, powder	30 to 35

Prices Per Lb.

LEAD SHEETS.

Montreal Toronto	
Sheets, 3 lbs. sq. ft.	\$16 00 \$16 00

Sheets, 3 1/2 lbs. sq. ft.	16 00	16 00
Sheets, 4 to 6 lbs. sq. ft.	15 50	15 50
Cut sheets, 1/2¢ per lb. extra.		
Cut sheets to size, 1¢ per lb. extra.		

PLATING CHEMICALS.

Acid, boracic	\$.15
Acid, hydrochloric	.05
Acid, hydrofluoric	.14 1/2
Acid, nitric	.10
Acid, sulphuric	.05
Ammonia, aqua	.08
Ammonium carbonate	.15
Ammonium chloride	.11
Ammonium hydrosulphuret	.40
Ammonium sulphate	.07
Arsenic, white	.12
Copper, carbonate, anhy.	.35
Copper, sulphate	.17
Cobalt sulphate	.70
Iron perchloride	.20
Lead acetate	.16
Nickel ammonium sulphate	.12
Nickel carbonate	.35
Nickel sulphate	.15
Potassium carbonate	.75
Potassium sulphide (substitute)	.20
Silver chloride (per oz.)	.65
Silver nitrate (per oz.)	.55
Sodium bisulphite	.10
Sodium carbonate crystals	.05
Sodium cyanide, 127-130%	.41
Sodium hydrate	.04
Sodium hyposulphite, per 100 lbs.	5.00
Sodium phosphate	.14
Tin chloride	.60
Zinc chloride	.60
Zinc sulphate	.09

Prices Per Lb. Unless Otherwise Stated.

The General Market Condition and Tendency

THE most important feature in industrial circles of recent date is the contemplated development of the shipbuilding industry. While plans have not yet been matured, it is understood that all the available shipbuilding capacity of this country will be utilized for the production of ships for the British Government. The threatened strike of railway employees in the United States has happily been averted, but there was considerable suspense for a few days, as it would have seriously affected business here. Prices of steel products continue to climb and the end of the upward movement is not yet in sight. Iron and steel bars and shapes have advanced this week approximately \$6 a ton, while higher prices on rivets, bolts and nuts, plates, tubes, black and galvanized sheets, are looked for in the near future. The situation in the steel trade is steadily improving and production is increasing. Hamilton foundry iron is again on the market at \$13 a ton, a new high level and one that will doubtless be surpassed. The pig-iron market is strong and active, while the situation shows some improvement in regard to more liberal supplies of coke. Prices of copper and other non-ferrous metals are unchanged from last week's level, but the market has a strong undertone and indications point to a continuance of high prices. The machine tool market, although comparatively quiet, is more active than earlier in the year. The demand consists largely for small lots or on single tools for munitions-plants. The scrap metal market is firm and prices have been well maintained during the week.

Montreal, Que., March 19, 1917.—

Several circumstances have combined to unsettle the general tone of the industrial situation. The threatened railroad strike was a disturbing element, but this danger has apparently been removed for the time being at least. The changed political conditions recently evolved in Russia will undoubtedly exert an indirect effect upon the industrial outlook there. Developments point to an early change in the attitude of the States, as

their "watchful waiting" policy has apparently reached the limit. The return of cold weather has delayed the breaking up of the ice on the rivers and lakes, and the opening of navigation will likely be somewhat later than usual.

Pig Iron

The market has again been featured with a further advance in pig iron, a \$1 increase being recorded at many centres. Pittsburg is now quoting \$33.95 for

basic, an advance on the week of \$3 per ton; Bessemer pig, on a \$1 rise, being quoted at \$37.95 per ton. Canadian quotations are still withdrawn.

Steel

Added to the pressure that has been so marked in all lines of manufacturing activity, steel industry may be confronted at any moment by the long delayed action of the United States Government in entering as a combatant in the now almost world-wide conflict in Europe and on the High Seas. The result of an actual war declaration is largely problematical at present, but what appears as a certainty would be the increased impetus given steel manufacture. This will, no doubt, mean much to the Canadian steel industry, as producers here may be compelled to increase their facilities to meet the needs of manufacturers who have been dependent on American steel in the past. Producers would likely be placed in a curious position owing to their future bookings, which in event of war might divert much of this tonnage into other channels. Developments in steel shipbuilding are making enormous strides, and as soon as plates are available the activity in this industry promises to equal, if not surpass, that of the present shell business. The nature of the undertaking, however, will confine it more to marine highways, the large rivers and seaports being the chief beneficiaries. Further advances in basic pig will probably affect the early future of steel prices, as many commodities are already showing a trend to higher levels. A feature of the situation is the reluctance of American roads to permit cars to enter Canada, due to the resultant delay in having the same returned for

further use. Producers of wire rods are able to use almost their entire output, but what surplus is available for sale is bringing the high price of \$85 per ton, this being an advance of \$5 per ton. The recent advance on wire product is well maintained and the demand continues, mills being booked well in advance. The strong position of plates has resulted in additional advances, and ship requirements are so great that higher levels are not unlikely. An advance of \$5 per ton has become effective in sheets, the Pittsburgh price on tin mill black being now \$5.25 per hundred.

Structural and boiler rivets have taken a jump of \$10 per ton, the respective quotations being \$4.75 and \$4.85 per hundred. The filled-up condition of wrought iron and boiler tube mills has prevented the heavy booking of additional business, and a stronger tone has developed. Local steel merchants are contemplating a revision of price lists, and intimate that the next few days will see some substantial changes in an upward direction. This has become necessary through the continual advance across the line, coupled with other contingencies.

Metals

The general situation has been somewhat disturbed during the past week by the threatened tie up of American railroads, but this nervousness has been partly removed by latest reports which indicate that this crisis will not develop at this time. For several days, embargoes were general at many points, owing to the action of railroads clearing themselves of perishable and urgent freight. With the exception of antimony, which is stronger, the metal situation shows an easier undertone. Copper is quiet and inactive. Tin is lower but uncertain. Consumers interest in spelter is marked by its absence and a weak tendency has developed. Lead is easier in the open market. Antimony is scarce and stronger. Aluminum is unsteady.

Copper.—The market is quiet and the tendency is for lower prices on what business is being transacted. A noticeable feature appears to be the increased available supply of metal for early future delivery. A closer check is to be placed upon export of American copper, the government having issued orders to withhold information regarding the shipment of metal. The London market is firm, but the American situation is apparently easier, New York quoting $1\frac{1}{2}$ cent lower on electrolytic. Dealers here report a weaker tone but prices are steady, lake and electrolytic being 43 cents, and castings 40 cents per pound.

Tin.—Owing to the safe arrival of tin and the apparent lessening of risk in transport, the market has taken on an easier tone and the movement is toward lower levels. Cautionness however, continues to prevail and sharp declines are not anticipated. The threatened railroad strike had the effect of disturbing the situation and spot tin was easier, but with this possibility removed the market has regained its steadiness, al-

though showing a weak undertone. London has become stronger but New York is quoting 53 $\frac{1}{4}$ cents, a decline on the week of $\frac{3}{4}$ cents per pound. With tin developing a weaker tone here, dealers continue to quote 53 cents on a steady market.

Spelter.—The lack of interest on the part of consumers has created a dullness that has reflected itself in lower quotations. The strength of the market is being maintained by the high cost of ore and the difficulty experienced in getting it delivered to the smelters. New York is quoting 103 $\frac{1}{4}$ cents, this being a decline of $\frac{1}{4}$ cent on the week. Local dealers are asking 15 cents on a quiet but firm market.

Lead.—The relief experienced by the improvement in railroad conditions has had the effect of putting lead on an easier basis and spot metal is more plentiful. London and New York continue firm, but independent American producers have reduced quotations to 10 cents; this being a decline on the week of one cent per pound. The local situation has taken on an easier tone, dealers here quoting 12 cents per pound.

Antimony.—The scarcity of spot metal, caused by the non-arrival of metal in transit, has developed a stronger market for prompt delivery, but the activity in futures is very light. New York quotations have advanced one cent on the week but local prices are firm and nominal at 34 cents per pound.

Aluminum.—The present demand is not heavy but the scarcity of metal tends to maintain a strong market; local quotations are firm at 70 cents per pound.

Machine Tools and Supplies

The situation shows a slight improvement over the previous week, but deliveries have been somewhat hampered by the recent railroad disturbance. The feature that dominates the present market is the unsettled condition prevailing across the line and the uncertainty of early future possibilities. With the prospect of definite action on the part of the American government, much of the available equipment, both new and second hand is being secured, for probable contingencies. With manufacturers operating on a home war basis, the industries here in Canada will be forced to rely more than ever upon their own resources for future requirements.

Scrap

The market for all classes of old materials continues to maintain strength, and higher levels, mark an active situation. The heavy demand for steel scrap and the difficulty of obtaining delivery point to stronger prices, and advances are not improbable. Brass scrap shows a better undertone but local dealers are holding firm on last week's quotations.

Toronto, Ont., March 20.—While the demand for manufactured products is still heavy, other features of the industrial situation are not so satisfactory. The threatened railway strike in the States promised to tie up the traffic and

dislocate business generally. Fortunately the trouble has been averted but it has left behind a feeling of unrest. The freight situation is gradually improving, but is not by any means satisfactory and manufacturers are still handicapped by a shortage of materials. Scarcity of labor is also adversely affecting production with no relief in sight. The contemplated development in the ship-building industry is expected to improve the demand for machine tools and the outcome of the proposals is being watched with interest. The scheme is an important one and its effect will be far reaching.

Steel

The situation in the iron and steel trade is steadily improving and the output of the mills is increasing in tonnage. The acute situation on the railways has been relieved to some extent, principally in regard to coal and coke, but conditions are not by any means normal. The decline in production during the first two months of this year has put the mills further behind on deliveries, while the demand for steel is not showing any indication of falling off. The steel market continues very strong and prices are still climbing. The recent advance in prices of steel bars and shapes in the States has been followed by higher prices in this market. Bars and shapes have advanced \$6 per ton and are now being quoted as follows. Iron bars, \$4.25; steel bars, \$4.50, and shapes, \$5 per 100 lbs. Higher prices in the near future may be looked for on plates, tubes, structural and boiler rivets, and spikes. The plate situation is the feature of the steel market. The demand is enormous with every indication of it becoming considerably heavier. The consumption of plates for shipbuilding, alone, is and will for a long time, be extremely heavy, while car builders are also taking considerable tonnages. The recent advance of \$15 a ton on plates in the U.S. was the sharpest made by the Carnegie Co. in many years. Wrought pipe is very firm at the recent advance and still higher prices are looked for.

About the end of the month there will likely be another advance in black sheets. An advance of \$5 a ton on black and blue-annealed sheets, and \$3 on galvanized sheets recently went into effect in the States. Freight conditions have improved, and the situation at the mills in regard to supplies of fuel and raw materials is easier. Labor costs, however, are higher and cost of production is, therefore, increasing.

Chicago warehouse prices on bars, plates and shapes have advanced and are now quoted as follows out of jobbers stocks: Bars, 4c.; plates, 5.50c.; and shapes, 4.25c. The steel market in the U.S. is very strong and prices continue to go up with further advances looked for on all steel products. The recent advances have had the effect of stimulating business, the demand for steel products being very heavy both export and domestic.

Pig Iron

The Steel Company of Canada have recently blown in their No. 2 furnace at

Hamilton and have issued a price of \$43 a ton on foundry iron. Supplies of coke are coming forward in better volume and the situation has consequently improved. The pig iron market is very strong and higher prices are likely at no distant date. There has been a general advance on practically all grades of pig iron in the States and the market there is unusually active. The demand for pig iron is ahead of the supply and a scarcity has developed. The coke situation has improved and prices are easier.

Scrap

The scrap market has been active during the week and prices have been maintained at the levels quoted last week. There has been fairly heavy buying of heavy melting steel and low phosphorus scrap. Cast iron scrap is also in good demand owing to the shortage of pig iron. Prices of copper and brass scrap are firm, but unchanged.

Machine Tools

The machine tool market is a little more active than earlier in the year. The demand continues to be principally for small lots or for single tools for munitions plants. This class of business, however, has fallen off considerably, although there is still fair demand for machine tools for munitions plants. Machine tool builders and dealers are showing a lively interest in the proposed development in the shipbuilding industry. It is expected that a good demand for shipyard machinery will spring up concurrently with existing shop extensions and improvements, and possibly also for new plants.

Supplies

An active demand for machine shop supplies prevails and prices are holding firm on practically all lines. Manufacturers of lubricating oils and cutting compounds announce that a revision of prices is under consideration and will be issued in a few days. It is likely that the new prices will show an advance over the present levels.

Metals

There are no new features of importance to note in the metal markets this week. With the International situation still unsettled there is a tendency on the part of consumers to await developments, consequently business is quiet. There is, however, a strong undertone to the markets due to the expectation of the United States taking an active part in the war. Prices are holding firm and are at the same level as last week for all metals. Business locally continues very good.

Copper.—The market is quiet and quotations easier, but unchanged. There is, however, a strong undertone to the market on account of the continued enormous consumption which shows no sign of diminishing. The demand for copper continues to exceed the supply and will continue to do so for the duration of the war. Lake and electrolytic copper is quoted at 40c., and castings at 39c. per pound.

Tin.—The market is dull and easier, although quotations are unchanged. A

new development in the market is the possibility of a tax being imposed by the British Government on the export of tin to the U.S. As shipments of tin have in the past been sufficient for requirements in the States it is doubtful if the proposed tax will be levied with the intention of conserving supplies in England. Local quotations unchanged at 56c. per pound.

Spelter.—The demand for spelter continues light with little prospect of any improvement in the meantime. The market is dull and quotations unchanged at 14c. per pound.

Lead.—There is no change in the situation. The market, although a shade easier has a strong undertone, the easier tendency being due to lack of demand. Local quotations are unchanged at 12¹/₂c. per pound.

Antimony.—There is still a scarcity of antimony particularly on large sized lots, which are practically unobtainable. The market is strong and quotations firm at 35c. per pound.

Aluminum.—The market is strong but quiet, and quotations are unchanged at 68c. per pound.

Sydney, N.S., March 16.—The coal mines throughout the province are working at full pressure, and production has been favored by the open weather that has characterized the winter in Nova Scotia. The reduction in the coal outputs seems temporarily stayed, owing to the restrictions on recruiting, but it is not likely that any increase over present outputs can be obtained. When the spring planting season starts there will be the usual exodus to the farms and fisheries, and there are no sources from which new workers can be obtained. It is to be hoped the National Service directors will not again allow the Maritime Provinces to be drained of laborers by the Western harvest excursions, as was the case last summer, when some 1,800 men, chiefly from the coal mines in Cape Breton and the munitions works at New Glasgow, left for the West.

One or two small ventures in coal mining are reported. The Greenwood Mine, in the Thorburn district, Pictou County, is producing some 200 tons daily from a small rise area of coal left from the workings of a previous operator, and is finding a ready sale for all the coal that can be produced. It is probable that the Broughton Mine, of the Cape Breton Coal, Iron & Railway Co., near Glace Bay, will be shortly reopened. This mine, owned by English capital, has been lying dormant for several years, and it is stated that a lease of the properties has been given to local parties, who expect shortly to commence unwatering the mine. There is also a possibility of some work being done at the Port Hood colliery, in Inverness County, which was flooded from the sea some years ago. It is not the intention to unwater the flooded section, but to work some rise coal, if this is found available in sufficient quantity. It is also reported that the Mabon colliery, in the same district, and also flooded by the sea, may be reopened.

Considerable interest is felt in Sydney in the newspaper reports of the intention of the British Government to encourage shipbuilding in Canada, through the medium of the Imperial Munitions Board. The people of Sydney have long been fully convinced of the excellent facilities which Sydney offers for a shipbuilding industry, among which may be mentioned the proximity of the large steel works of Cape Breton Island, the nearness of the coal mines, and the capacious and safe harbor which Sydney possesses. Strong efforts are to be made to secure the most favorable consideration of Sydney as a location.

CANADIAN TRADE INCREASES IN VOLUME

THE volume of Canadian trade maintains a steady tendency, according to a statement just issued by the Minister of Customs. For the eleven months of the present fiscal year ending February 28 last, the exports of Canadian products and manufacturers reached the large total value of \$1,028,960,000. For the same period merchandise entered for Canadian consumption totalled \$742,995,000, an excess of exports over imports of \$285,065,000. These figures are exclusive of the imports and exports of coin and bullion and the export of foreign merchandise. The total merchandise for domestic consumption and export reached \$1,771,955,000 for the eleven months of the present fiscal year, compared with \$1,098,945,000 for the corresponding eleven months of the fiscal year 1916.

For the month of February last Canada's trade was \$136,254,000, against \$109,586,000 for February, 1916, these figures being exclusive of foreign merchandise passing through Canada and the exports and imports of coin and bullion. Of the exports for February last, manufactures led the way with \$39,504,000; agriculture, \$11,319,000; animals and their products, \$7,652,000; minerals, \$5,074,000; fisheries, \$1,655,000; products of the forest, \$2,459,000.

Increase of Exports.

With the exception of agriculture, the exports of which have fallen off to the value of \$2,000,000 from February, 1916, these exports show a large increase over the corresponding month of last year, when the total exports were \$57,931,000.

For the eleven months of the present fiscal year the largest increase is shown in the export of manufactured articles, being \$108,160,000 for the eleven months ending February, 1917, as against \$195,021,000 for the corresponding eleven months of 1916. The exports of agricultural products were \$351,451,000, against \$231,808,000; animals and their products, \$112,985,000, against \$91,255,000; products of the forest, \$52,292,000, against \$18,023,000; minerals, \$75,636,000, against \$58,585,000; fisheries, \$22,515,000, against \$20,323,000.

Imports for February

The figures respecting imports for February show a large increase in the value of dutiable goods and free goods.

Dutiable goods imported during Febru-

ary last totalled \$36,490,000, as against \$29,097,000 for February, 1916. Free goods also show a substantial increase, being \$31,540,000 for February last, against \$22,557,000 for February, 1916.

For the eleven months ending February last the total imports of dutiable goods were \$407,136,000, against \$254,551,000 for the corresponding period of 1916. Free goods were \$335,585,000, as against \$191,196,000.

The duty collected for the eleven months ended February last was \$130,550,000, as against \$91,757,000 for the corresponding period of 1916.

FINANCING SALES ABROAD BY DRAFTS

IN its issue of February, the *Foreign Trade Bulletin* of the American Express Co. sets forth the following instructions for financing sales abroad by drafts. Extending credit to foreign buyers does not involve a tie-up of the manufacturer's capital, when shipments are financed by drafts. No manufacturer of good standing need wait for his money on such sale. His draft against his foreign customer, drawn payable to his own order and endorsed with his signature, can be discounted, thus providing the manufacturer with the funds necessary for his own current business. Discounting charges are paid usually by the foreign buyer, because the buyer receives time accommodation for which he is willing to pay. These charges may or may not be apparent on the face of the draft itself, although the net result is the same in that the drawee pays costs. For instance, most dollar drafts against Far Eastern importers, as well as some against South American drawees, bear the clause "payable with interest at 6 per cent. per annum from date of issue to approximate due date of arrival of cover in New York." The use of that clause varies according to the country in which draft will be collected, and according to the terms of sale agreed upon between buyer and seller.

Why Importers Demand Credit

The reason for the foreign customer's willingness to pay costs of discounting drafts is identical with the reason for his demand for credit. In most foreign territories, particularly in South America and the Orient, money rates are high. Local banks charge borrowers anywhere from eight to eighteen per cent. for money advanced. The local importers who does business with American manufacturers on a cash basis therefore penalizes himself by paying the high money rate, if there is any chance of securing goods on credit terms that permit him to pay 6 per cent. for the accommodation under time drafts.

European exporters have always recognized this condition, and, for the money rate, have been liberal in credits. That is they have been willing to sell foreign buyers under "documents against acceptance of draft" terms, whereby the purchaser obtained accommodation on a six per cent. basis, and the discounting banker carried the credit. In between the American manufac-

turer and his foreign customer comes the banker. The banker really extends the credit when he discounts a draft. The banker is protected primarily by the endorsement of the manufacturer. At the foreign end, the banker is protected by the control of the shipment itself, which is represented by shipping documents attached to the draft. The foreign buyer cannot obtain the shipment until he has paid or "accepted" the draft in the banker's possession. The act of acceptance consists in the endorsing of the draft by the buyer abroad with his signature and the date. Not until such acceptance or payment can the buyer obtain the bills of lading controlling the shipment.

Figuring Amounts on Dollar Drafts

In drawing a dollar draft, the American manufacturer has just one thing to bear in mind, the cash amount he must receive to clear himself at time the draft is discontinued. To show how a \$1,000 shipment goes forward under a draft for \$1,027.50, so that the manufacturer may "break even," consider the following sale to a Buenos Aires

CANADIAN GOVERNMENT PURCHASING COMMISSION

The following gentlemen constitute the Commission appointed to make all purchases under the Dominion \$100,000,000 war appropriation:—George F. Galt, Winnipeg; Hormidas Laporte, Montreal; A. E. Kemp, Toronto. Thomas Hilliard is secretary, and the Commission headquarters are at Ottawa.

customer under the common credit terms of "ninety days." Assume that amount of manufacturer's invoice, including cost, insurance, freight and incidental charges is exactly \$1,000. Interest is usually figured from date of sailing, and the charge would cover 150 days; 30 days to Buenos Aires, 90 days for the term of draft, and 30 days for return funds. Interest at 6 per cent. for 150 days is \$25. To this should be added the bank's usual collection commission, say one-quarter per cent., or \$2.50. The draft by the manufacturer should therefore be for \$1,027.50, which, when discounted in New York, would net the manufacturer the useful \$1,000.

Dollar drafts should always be drawn with the clause: "Payable at the holding bank's selling rate of exchange for sight bills on New York." Drafts, as well as invoices, marine insurance policy, consular invoices, etc., should be drawn in duplicate, so that the extra set can be sent forward by a different steamer, to protect against possible loss of originals in the mail.

Collection Instructions Required

American manufacturers should always provide bankers with definite in-

structions as to conditions under which controlling documents (bills of lading, and insurance policies) should be surrendered to drawees. That is, whether such documents are to be delivered upon "acceptance" of draft—or against "payment." In certain lines the custom is to ship goods under time drafts, but to deliver documents only upon payment. The goods remain under control of the collecting bank for the time intervening before payment. In these matters, bankers always require instruction, as well as on the "protesting" of unpaid or unaccepted drafts. Procedure in drawing drafts often varies, according to the country of destination. In Australia, for instance, an important "colonial clause" on sterling drafts simplifies the figuring of interest and exchange, while a charge from draft to cheque form for collections on certain European countries saves appreciable amounts for stamp fees.

CANADIAN FAIRBANKS-MORSE PENSION FUND

BECOMING effective January 1, 1917, a pension plan has been put into operation by the Canadian Fairbanks-Morse Co., according to an announcement by H. J. Fuller, president. It has been inaugurated by the directors of the company as an evidence of their appreciation of the faithful service of their employees, the system applying to all salaried employees fulfilling certain conditions.

The members of the fund shall consist of the officers and salaried employees of the Canadian Fairbanks-Morse Co., who have been in the employ of the company for six consecutive months, together with such other classes of employees as may be hereafter determined upon by the directors. In the term "salaried employee" are included all the employees at the head office, and at branch houses and sales warehouses, irrespective of the basis of payment.

Contributions are to be deducted from the individual pays and credited to the fund at the rate of 3 per cent. in equal monthly or weekly instalments, which cease when the contributor becomes a pensioner, and do not apply to portions of salaries above \$4,000 per annum. The company on its part will contribute to the fund 3 per cent. annually of the amount upon which individual contributions are based, this sum being payable in monthly instalments. All present and future officers of the company, both male and female, eighteen years of age and over, will be required to contribute, excepting such as may be excused by the directors. Male and female contributors who have been continuously employed for not less than twenty years may be retired voluntarily or otherwise, and become eligible for a pension on attaining the ages of sixty and fifty years respectively.

The annual pension allowance for not less than twenty years' contribution is at the rate of 2 per cent. of the average annual pay (not exceeding \$4,000) during the ten years preceding retirement.

for each year of service, with a deduction of an amount equal to 1 per cent. thereon for each year short of twenty.

Various provisions are made for such cases as pensioners' widows, children, etc., also the payment of interest on the fund balance of 4 per cent. per annum.



TRADE GOSSIP

The Boving Hydraulic and Engineering Co., of Lindsay, Ont., have been awarded a contract for a centrifugal pump by the City of Welland, Ont.

Prepare for After War.—Sir George Foster was in conference at Ottawa last Friday with a number of prominent Canadian producers, including representatives of manufacturing, farming, and other interests. Their views were taken on the advisability of holding some time later a national business conference to consider preparation for after-the-war problems. Among those in attendance were F. L. Wanklyn, of the C.P.R., and E. Hebert, of the Chamber of Commerce, Montreal; G. M. Murray, of the C.M.A.; C. A. Bogart, of the Bankers' Association; A. H. Brittain, of the Maritime Fish Corporation, and Col. O. McEwen, of Byron, Ont., representing agricultural interest.

To Develop B. C. Iron Ores.—The Hon. Mr. Sloan, Minister of Mines in the B. C. Legislature, said recently that it was the intention of the Government to do diamond drilling on various iron properties and they hoped within a few months to show a certain amount of ore actually blocked out. We will also, he said, divide the province into mining areas, each in charge of a competent mining engineer, so that the Government will be gathering data constantly. The iron industry, if established in the province, will lead to many other industries and the Government is anxious to bring it here if we can satisfy ourselves that we have the ore in proper quantity and other conditions are favorable.

R. S. White Honored.—A number of customs brokers of the City of Montreal met at the Customs House on McGill street, on Saturday, March 10, for the purpose of bidding a formal farewell to R. S. White, on the occasion of his retiring from office after over a score of years of service as collector of customs. The customs brokers took advantage of the occasion not merely to voice their appreciation of the manner in which Mr. White had performed the functions of his office during that time, but showed their feelings in very tangible form, presenting Mr. White with three superb pieces of silverware, and with an illuminated address. While the ceremony was a very brief one, it was marked by a continuance of the warm personal friendly relations that have always prevailed between Mr. White and those who had business to do with his department, and many feeling tributes were paid him by his friends of the business community. John A. Finlayson presided, and called upon S. Whitaker to present the address.

Enlarged Canadian Trade Intelligence Service

Under the arrangement made by the Minister of Trade and Commerce with Sir Edward Grey in July, 1912, the Department of Trade and Commerce, Ottawa, is able to present the following list of the more important British Consulates whose officers have been instructed by the Foreign Office to answer inquiries from and give information to Canadians who wish to consult them in reference to trade matters.

BRAZIL—Bahia, British Consul. Rio de Janeiro, British Consul General.	NETHERLANDS—Amsterdam, British Consul.
CHILE — Valparaiso, British Consul General.	PANAMA—Colon, British Consul. Panama, British Vice-Consul.
COLOMBIA — Bogota, British Consul General.	PERU—Lima, British Vice-Consul.
ECUADOR—Quito, British Consul General. Guayaquil, British Consul.	PORTUGAL—Lisbon, British Consul.
EGYPT — Alexandria, British Consul General.	RUSSIA—Moscow, British Consul General. Petrograd, British Consul. Vladivostok, British Consul. Odessa, British Consul General.
FRANCE—Havre, British Consul General. Marseilles, British Consul General.	SPAIN—Barcelona, British Consul General. Madrid, British Consul.
INDIA—Calcutta, Director General of Commercial Intelligence.	SWEDEN—Stockholm, British Consul.
ITALY—Genoa, British Consul General. Milan, British Consul.	SWITZERLAND—Geneva, British Consul.
MEXICO—Mexico, British Consul General.	URUGUAY—Monte Video, British Vice-Consul.
	VENEZUELA — Caracas, British Vice-Consul.

Canadian Commercial Intelligence Service

The Department of Trade and Commerce invites correspondence from Canadian exporters or importers upon all trade matters. Canadian Trade Commissioners and Commercial Agents should be kept supplied with catalogues, price lists, discount rates, etc., and the names and addresses of trade representatives by Canadian exporters. Catalogues should state whether prices are at factory point, f.o.b. at port of shipment, or, which is preferable, c.i.f. at foreign port.

CANADIAN TRADE COMMISSIONERS.

ARGENTINE REPUBLIC—H. R. Poussette, Reconquista, No. 46, Buenos Aires. Cable address, Canadian.
AUSTRALIA—D. H. Ross, Stock Exchange Building, Melbourne. Cable address, Canadian.
BRITISH WEST INDIES—E. H. S. Flood, Bridgetown, Barbadoes, agent also for the Bermudas and British Guiana. Cable address, Canadian.
CHINA—J. W. Ross, 13 Nanking Road, Shanghai. Cable address, Cancom.
CUBA—Acting Trade Commissioner, Lonja del Comercio, Apartado 1290, Havana. Cable address, Cantracom.
FRANCE—Phillipe Roy, Commissioner General, 17 and 19 Boulevard des Capucines, Paris. Cable address, Stadacona.
JAPAN—G. B. Johnson, P. O. Box 109, Yokohama. Cable address, Canadian.
HOLLAND—Acting Trade Commissioner, Zuidblaak, 26, Rotterdam. Cable address, Watermill.
RUSSIA—C. F. Just, Canadian Government Commercial Agent, Alexandriyskaya, Ploshch 9, Petrograd. L. D. Wilgress, Canadian Government Commercial Agent, Bukhgozla Ulitza No. 4, Omsk, Siberia.
NEWFOUNDLAND—W. B. Nicholson, Bank of Montreal Building, Water Street, St. John's. Cable address, Canadian.
NEW ZEALAND—W. A. Redde*, Union Buildings, Customs Street, Auckland. Cable address, Canadian.
SOUTH AFRICA—W. J. Egan, Norwich Union Buildings, Cape Town. Cable address, Cantracom.
UNITED KINGDOM—Harrison Watson, 73 Basinghall Street, London, E.C., England. Cable address, Sloughing, London. N. D. Johnston, Sun Building, Clare Street, Bristol. Cable address, Canadian. J. E. Ray, Central House, Birmingham. Cable address, Canadian. J. Forsyth Smith, 27-28 Pearl Building, East Paradise, Leeds. Cable address, Canadian. F. A. C. Bleckerdike, Canada Chambers, 36 Spring Gardens, Manchester. Cable address, Cantracom. J. T. Litigow, 87 Union Street, Glasgow, Scotland. Cable address, Cantracom.

SPECIAL TRADE COMMISSIONER—LUMBER

H. R. McMillan, visiting Europe, Africa, Australasia and the Orient.

CANADIAN COMMERCIAL AGENTS

AUSTRALIA—B. Milha, Exchange Building, Sydney, N.S.W.
BRITISH WEST INDIES—Edgar Tripp, Port of Spain, Trinidad. Cable address, Canadian. R. H. Curry, Nassau, Bahamas.
NORWAY AND DENMARK—C. E. Soutum Grubbedeg No. 4, Christiania, Norway. Cable address, soutums.

CANADIAN HIGH COMMISSIONER'S OFFICE

UNITED KINGDOM—W. L. Griffith, Secretary, 17 Victoria Street, London, S.W., England. Cable address, Dominion, London
--

INDUSTRIAL ^A_N^D CONSTRUCTION NEWS

Establishment or Enlargement of Factories, Mills, Power Plants, Etc.; Construction of Railways, Bridges, Etc.; Municipal Undertakings; Mining News

ENGINEERING

Montreal, Que.—The G.T.R. has received bids on machine tool equipment for the new shops at Port Huron, Mich.

Hamilton, Ont.—The Union Drawn Steel Co. proposes to build a large addition in connection with its present plant.

Dundas, Ont.—It is understood that the Chapman Engine Co. will rebuild their plant, which was recently damaged by fire.

Ladysmith, B.C.—The Ladysmith Smelter Co. will spend \$100,000 on additions to its smelter at Ladysmith. W. J. Watson is superintendent of the plant.

Belleville, Ont.—The Maple Leaf Tires Co. is erecting a plant here at a cost of \$100,000, and will be shortly ready for the installation of equipment. O. W. Dunham is secretary.

Edmonton, Alta.—The Western Shell & Box Co. is in the market for an 18-in. engine lathe, about 4 in. belt, for heavy duty; also universal milling machine and dividing head.

Niagara Falls, Ont.—The Herbert Morris Crane & Hoist Co., of Toronto has purchased a site here for a factory. No plans have however yet been definitely decided upon regarding building operations.

Chatham, Ont.—The sale of the plant of the Chatham Bridge Co. to the Pittsburgh and Des Moines Steel Co. has been endorsed by the shareholders, and it is expected that the deal will be finally closed within the next few days.

St. John, N.B.—Plans are well perfected for the organization of the St. John Shipbuilding Co., with a capital of one million dollars, to operate under a Dominion charter and construct ships here, at first wooden ones and later steel vessels.

Montreal, Que.—The Thomas Davidson Mfr. Co., will install four 6-ton electrical furnaces at their new steel plant at Cote St. Paul. The electrical equipment will consist of four 1,350 k.v.a. transformers, two motor generator sets, switchboard, etc.

Midland, Ont.—It is understood that the Port Arthur Copper Co. will install a reverberatory furnace at the reduction plant at Midland for smelting copper ores. This furnace will be operated in combination with the company's blast furnace, and will be ready, it is stated, for ore by May 1 next.

Toronto, Ont.—The Town Council's application to grant aid to the British Chemical Co. by granting exemption from all taxes "except school taxes" to pay \$10,000 towards the purchase of site for the works of the company and close certain streets laid out on plan site was granted.

Port Hope, Ont.—J. N. Kittson and

associates of Hamilton, Ont., have purchased the plant of the Brandon Shell Manufacturing Co., Port Hope. The new firm will have the balance of the machinery installed at once and proceed with all possible speed with the manufacture of shells.

Goderich, Ont.—Final arrangements have been completed whereby the town disposes of the plant known as the Doty Marine & Engine Co., the purchaser being W. H. Hutchinison, of St. Catharines, Ont., contractor of section two of the new Welland Canal. It is understood that the purchase price is \$30,000.

St. Thomas, Ont.—Motor radials for a number of routes in Elgin and Middlesex counties were announced on March 15 after the organization meeting of the Interurban Motor Co. The company is capitalized at \$100,000, and will operate large motor buses, each capable of seating 26 persons, as well as heavy freight trucks, from St. Thomas to Aylmer and return, from Union to Sparta and return, and from Delaware to Lambeth and return. W. N. Warburton is the general manager of the company.

ELECTRICAL

Havelock, Ont.—The Town Council decided to ask the Hydro-Electric Commission to supply power to the village.

Melfort, Sask.—A new switchboard will probably be installed at the central telephone exchange. The cost is estimated at \$1,000.

Brussels, Ont.—The introduction of hydro-electric power is being considered. The power would be developed at Inglis Falls, near Owen Sound.

MUNICIPAL

Montreal South, Que.—A waterworks system is under consideration at a cost of about \$180,000.

St. Catharines, Ont.—The Town Council contemplate making improvements to the waterworks plant.

Leamington, Ont.—The Town Council contemplates installing a tank with a capacity of 900,000 gallons.

Oakville, Ont.—The Aeme Rubber Co. tax exemption by-law has been finally passed and is now in force.

Midland, Ont.—The by-law to grant assistance to the shipbuilding plant was carried by a substantial majority.

Bridgeburg, Ont.—The Town Council are considering the purchase of a pump and motor for the waterworks plant.

Aurora, Ont.—The Town Council contemplate installing a sewage disposal plant. James, London & Hertzberg, of Toronto, are the engineers.

Toronto, Ont.—Work on the new Don incinerator has been practically completed and operations will commence, it is expected, about the end of this month.

London, Ont.—The Utilities Commission has decided to connect the Foster wells with the city system, at a cost estimated at \$47,000. Two new wells will be sunk at once.

Oshawa, Ont.—The Town Engineer has submitted his report to the Council on the installation of new filters and improvements to the sewage plant. The report was adopted.

Montreal, Que.—The Board of Control will proceed with the construction of the LaSalle bridge and the head-gates to be placed at the intake of the aqueduct.

Penticton, B.C.—The City Council contemplate extending the civic power plant and installing additional equipment which would consist of a Diesel engine and electrical machinery.

Cobourg, Ont.—The ratepayers carried a by-law granting the Cobourg Felt Co. a loan of \$10,000, which is secured by a mortgage on the plant, and is to be repaid in ten annual consecutive instalments of \$1,000 each.

Windsor, Ont.—A by-law will be submitted to the ratepayers on March 26 to grant aid by way of a bonus to Max Goldman and Samuel Harris, who propose to carry on the business of smelting and refining brass and other metals.

Windsor, Ont.—Peter Osterhout proposes to erect a factory for making cement, brick and other products. A by-law will be voted on by the ratepayers on March 26, to authorize aid in the form of a bonus for this industry.

St. Hyacinthe, Que.—A mechanical filtration plant will be installed here having a capacity of four million gallons per day. The filters will be supplied by the Roberts Filter Mfg. Co., of Darby, Pa. Pumps, steam turbine and electrical equipment will also be installed.

Renfrew, Ont.—The Town Council has decided to pass a by-law giving M. J. O'Brien the right to run wires from his plant at Calabogie into the town, but the town will buy power from him and deliver it to users, making purchases from him only after all the civic power available is in service. Permission is given for the carrying of power from Calabogie through the town for delivery in other municipalities.

New Toronto, Ont.—The New Toronto Council, at a special meeting on March 13, instructed the engineers to prepare plans for waterworks extension amounting to about \$40,000. This will include a new sedimentation well, two new pumps, pump-house extension, and mains on New Toronto street and Eighth street. The municipality owns approxi-

WELD IT ELECTRICALLY

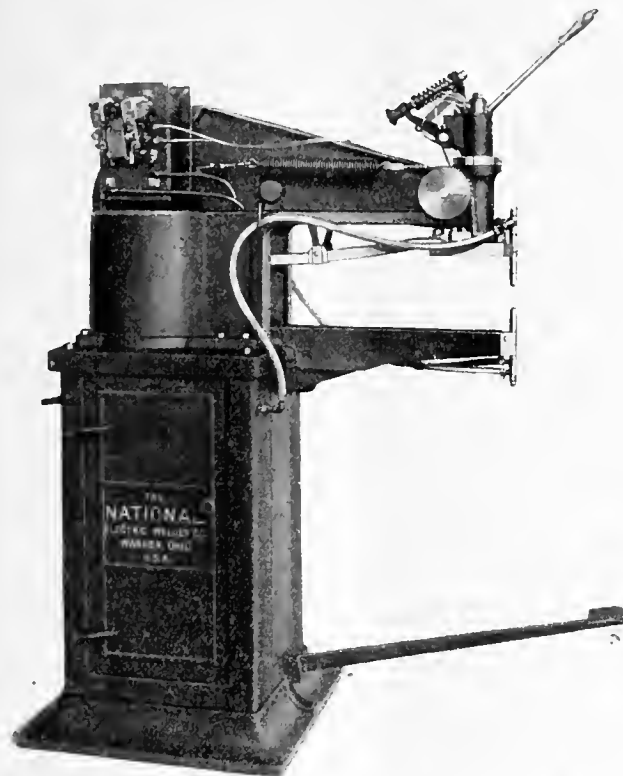

Let the **NATIONAL** do it

Electric Welder

Your riveting costs can be reduced 50 to 300 per cent.

There are few examples of riveting which cannot be better handled by an Electric Welder.

If you are riveting, let us make you a proposition on welding with a **NATIONAL** Electric Welder.

Can be supplied for any alternating current circuit.

Write now for full information, giving voltage and frequency of your line.

The A. R. Williams Machinery Company, Limited

64 Front St. W. Phone Adel. 20 **TORONTO**
"Canada's Leading Machinery House"



Soon Pays For Itself

That is one of its credentials

A Geometric Threading Machine is the economical way of producing small threaded parts. It is complete with countershaft, change speed gear, adjustable stop for gauging length of thread; and takes floor space 2 ft. x 3 ft. only.

Insures accuracy and greatest production of duplicated threaded parts. Not the usual bolt threading machine. No rough threads with the Geometric.

Send for our Threading Machine Booklet and let it tell you the value of the machine.

The Geometric Tool Company
New Haven, Conn., U.S.A.

Canadian Agents:- Williams & Wilson, Ltd., Montreal;
The A. R. Williams Machinery Company Limited,
Toronto, Winnipeg, St. John, N.B.

If any advertisement interests you, tear it out now and place with letters to be answered.

mately 200 feet of lake frontage and propose building a stone set wall.

Saskatoon, Sask.—The Finance Committee has the following expenditures under consideration in addition to the proposed incinerator: Cold storage plant, \$6,000; water softening plant, \$14,800; ash handling plant, \$10,000; motor chemical truck, \$1,000; fire alarm boxes, \$2,500; street railway improvements, \$16,640; two street cars, \$15,000; motor generator for police and fire patrol signal systems; alternating power house boilers, \$7,000; completing force water main contract, \$25,000, and electrical connections, \$6,000.

GENERAL

Chambly, Que.—The Canadian Leath-board Co. will build a factory here.

Trenton, Ont.—The T. Eaton Co., of Toronto, have purchased a site here for a creamery. Building will start at once.

Windsor, Ont.—The Canadian Oil Co. propose establishing a business for making lubricants, oils, paints, etc. A factory site will be given the company provided a by-law passes on March 26.

Winnipeg, Man.—The terminal elevator of the Northern Elevator Co., situated on the C.P.R. tracks, was destroyed by fire on March 9. The estimated loss is about \$150,000, including building contents and machinery.

London, Ont.—The Hunt Bros.' City Mills will not remove from London. The city retains this industry through the efforts of the Industrial Commission, which has just completed an arrangement whereby the present mill site and water rights are purchased for \$15,000 by the Public Utilities Commission. The latter will get new tenants, while the Hunts will commence the erection at once of a \$150,000 plant in the east end.

Victoria, B.C.—The announcement was made at Bellingham recently by John E. Rice, president of the Lummi Bay Packing Co., that it was the intention of that concern to build two salmon canneries this spring on Vancouver Island. The main cannery will be at Nitinat and the other close to that place. The two plants will cost approximately \$100,000. A cold storage plant is included in the company's plans, in addition to which they will build five tenders and seine boats for the use of the two canneries.

TENDERS

Toronto, Ont.—Tenders will be received for a building until April 9, addressed to the Toronto Harbor Commissioners, 50 Bay Street, Toronto, Ont.

All information may be obtained by applying to the Architects, Chapman and McGiffin, 95 King Street East, Toronto.

Toronto, Ont.—Tenders, addressed to the chairman of the Toronto Electric Commissioners, will be received until March 28 for synchronous condensers.

Specifications may be obtained at the office of the purchasing agent, 15 Wilton avenue, Toronto.

Cartwright, Man.—Tenders will be received by the Rural Municipality of Roblin up to April 5 for abutments and steel work for four bridges. Plans, specifications and tender forms may be seen at office of Highway Commissioner, Winnipeg, or at the office of Secretary-Treasurer, Cartwright, Man.

Toronto, Ont.—Tenders for synchronous condensers, addressed to the chairman of the Toronto Electric Commissioners, will be received until March 28. Specifications, form of tender and all information desired may be obtained at the office of the purchasing agent, 15 Wilton avenue, Toronto.

Toronto, Ont.—Tenders will be received up to April 2, addressed to the chairman of Toronto Harbor Commissioners, 50 Bay Street, Toronto, for the construction of harbor head walls. All information may be obtained by applying to the above address. E. L. Cousins, chief engineer and manager.

St. Felix de Valois, Que.—Tenders will be received until March 31, at the office of the corporation of the parish of St. Felix de Valois, for the construction of an iron bridge in this parish. The plans and specifications can be seen every day at the Office of the corporation. J. H. Lavallee, sec-treas.

Hamilton, Ont.—Tenders addressed to Chairman of Board of Control will be received up to April 5 for the supply and delivery of one combined motor driven flusher and sprinkler to conform to the following general specifications: Tank capacity, 1,200 Imperial gallons; truck not less than 5-ton; separate motor for flusher apparatus. Further particulars on application to the Secretary of Works Department, City Hall, Hamilton.

Quebec, Que.—Tenders, addressed to the secretary-treasurer of the Municipality of Halifax South, will be received until March 25, for the construction of two highway bridges, with steel superstructure, concrete abutments, approaches, etc., on the Frontier and Pigeon Rivers (ten arpents distant) in the parish of St. Ferdinand d'Halifax, Megantic county. Plans and specifications may be examined at the Council's office and at the Department of Public Works and Labor, Quebec.

CONTRACTS

Montreal, Que.—It is understood that the Canadian Car & Foundry Co. have received an order for 2,000 freight cars from the Russian Government.

Victoria, B.C.—It has been announced by Capt. J. W. Troup, manager of the B. C. Coast Steamship Service, that Clarence Hoard, of this city, had been awarded the contract for the building of one of the C. P. R. car-barges, and that possibly Mr. Hoard, who is a well-known contractor, would also secure the contract for the second barge which the C. P. R. decided recently to have built

here. Each of the barges will have a capacity for holding nine cars.

PERSONAL

James P. Wood, a member of the firm of Wood Bros., foundry, died at Chatham, Ont., on March 16, aged 45.

A. E. Johnson, engineer, Dominion Bridge Co., Montreal, is visiting New York in connection with some large contracts.

D. J. McCuaig has been appointed acting master mechanic of Ontario lines, with headquarters at Toronto, in place of **W. G. Sealey**, assigned to other duties.

George Forest McKay died at New Glasgow, N.S., on March 13, at the age of 82 years. Mr. McKay assisted in the founding of the Nova Scotia Steel & Coal Co., and was its oldest director.

R. M. Hoffman has recently been appointed manager of sales of the Hesse-Martin Iron Works, Portland, Ore. He is a mechanical engineer, and has been connected with the Messe & Gottfried Machinery Co. in both its Seattle and Vancouver plants.

J. A. Sanderson, a prominent business man of Brantford, Ont., died at his home in that town on March 14. The deceased was a native of this district and was 60 years of age. He was president of the Brantford Carriage Co., and a director of the Cocksitt Plow Co. He was one of the original promoters of the Lake Erie & Northern Railway.

J. W. Norcross, vice-president and managing director of the Canada Steamship Lines, has been appointed director of shipbuilding in Canada, attached to the Naval Service Department. The Government is anxious to immediately carry out an undertaking for the construction of as large a number of merchant vessels as possible at the various shipbuilding works and dry docks in Canada, and has placed the entire undertaking in the hands of J. W. Norcross, with powers to forthwith proceed with the organization of his staff and the placing of the contracts, in order that the largest number of boats may be launched at the earliest possible date.

Capt. Gilbert Johnston, a well-known figure on the St. Lawrence and the Great Lakes, and long actively connected with the Richelieu & Ontario Navigation Co. and the Canada Steamship Lines, Ltd., died at his residence in Montreal on March 13, after a long illness. He was known to practically all of the river and lake steamboat men in this part of the Dominion, and had a very wide circle of friends and acquaintances. Captain Johnston was of Scottish ancestry and was born in Kingston, Ont., sixty-four years ago, being a son of the late Gilbert Johnston. In 1894 he was appointed mechanical superintendent for the Richelieu & Ontario Navigation Co., a position which he filled with conspicuous success. After receiving this appointment he removed from Kingston to Montreal, and resided here for the remainder of his life. He retired from active work with the Canada Steamships, Ltd., six months ago.

Aikenhead's

Van Dorn
Portable Electric Drills

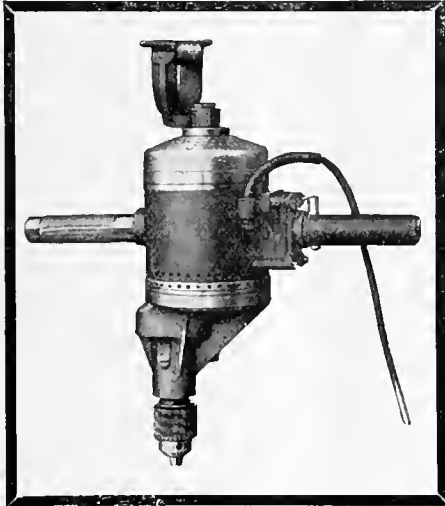

Solve the Hole Problem

They drill more holes in America than any other make

DA00	Capacity	$\frac{1}{4}$ in.	in Steel
DA0	"	$\frac{3}{8}$ in.	" "
DA1	"	$\frac{1}{2}$ in.	" "
DA1X	"	$\frac{5}{8}$ in.	" "
DA2	"	$\frac{7}{8}$ in.	" "
DA2X	"	1 in.	" "

ALL SIZES IN STOCK, TORONTO

AIKENHEAD HARDWARE LIMITED

17 TEMPERANCE STREET, TORONTO

Aikenhead's **New Chuck**

Are You Increasing Your Production?

Or are you still running along "trying" to meet those rush orders? With the

Wahlstrom Automatic Chucks

you are absolutely sure of boosting your output. The Pierce-Arrow, The Cleveland Automatic Machine Co., and numerous other large firms have done it, and so can you. We have a demonstration offer that you should investigate—it will pay you.

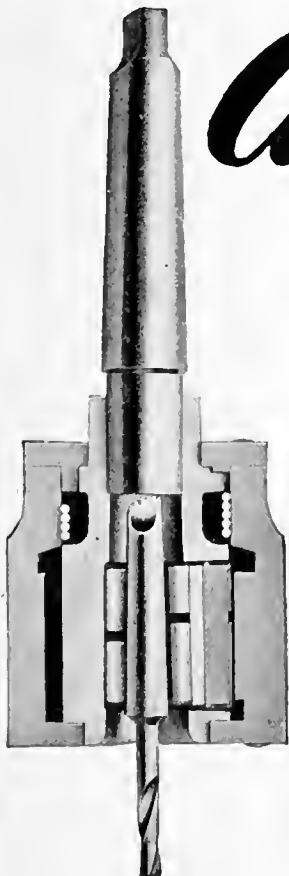

Aikenhead Hardware Co., Limited

17, 19, 21 Temperance Street

Toronto, Canada

If any advertisement interests you, tear it out now and place with letters to be answered.

PATENT ATTORNEYS

BABCOCK & SONS

ESTAB. 1877

PATENTS—TRADE MARK—DESIGNS
IN ALL COUNTRIES

Book "Patent Protection"—free. Master of Patent Laws. Formerly Patent Office Examiner.

99 St. James St., - Montreal, Que.
Branches: Ottawa, Washington.

RESEARCH BUREAU

REPORTS BY EXPERTS ON SCIENTIFIC, TECHNICAL AND INDUSTRIAL DEVELOPMENT.

SPECIAL RESEARCHES ARRANGED.

PATENTS, TRADE MARKS, ETC.

HANBURY A. BUDDEN

CABLE ADDRESS

712 DRUMMOND BLDG., MONTREAL

"BREVET"

PATENTS

Fetherstonhaugh & Co.
Patent Solicitors. Head Office,
Royal Bank Bldg., Toronto.
Ottawa Office, 5 Elgin St.
Send for our Plain Practical
Pointers. Copy of National
Progress, in which our patents
are advertised, mailed free.

PATENTS PROMPTLY SECURED

In all countries. Ask for our Investor's Adviser, which will be sent free.

MARION & MARION, 364 University St.

Merchants Bank Building, corner
St. Catherine St., MONTREAL, Phone Up. 6474
and Washington, D.C., U.S.A.

SPECIAL MACHINERY

GAUGES, FIXTURES, DIES
AND
PRECISION TOOLS

WE HAVE THE
MOST MODERN
EQUIPMENT
TO HANDLE
ANY CLASS OF WORK

CANADIAN DISTRIBUTORS FOR THE

**ALBANY PATENT ROTARY
PUMP**

Albany Pump Co.

16 Pearl St., TORONTO, Canada

Phone Ad. 2511 A. W. Bennet, Manager

TRADE GOSSIP

The Canadian Fairbanks-Morse, Toronto, have been awarded a contract for a centrifugal pump by the town of Waterloo, Ont.

The Vanadium-Alloys Steel Co., Pittsburgh, Pa., announce that they have obtained the services of T. C. Chown, 4276 Westmount avenue, Montreal, who will assist P. F. Fosnight, the company's Canadian manager.

The Wells & Gray Co., contractors, Toronto, have been awarded a contract for a sporting goods factory for the Peters Cartridge Co., Cincinnati, Ohio, to cost around \$300,000.

The Aetna Iron & Steel Co. has moved its offices from Victoria, B.C., to 916 Standard Bank Bldg., Vancouver. The company has leased with option of purchase the Port Moody Steel Works. The entire plant is being rearranged and a new open-hearth furnace is being constructed. David Milne is the managing director.

The James McKay Co., Pittsburgh, maintains an office in charge of John A. Buchanan in the King Edward Hotel in Toronto, Ont. The company is selling a large part of its output in Canada, comprising mechanical, marine and stud-link marine chain, anchor shackles, hooks, etc., and commercial and special forgings.

Brown's Copper & Brass Rolling Mills, Ltd., New Toronto, Ont., have erected a handsome office building adjacent to their mills on the Lake Shore Boulevard, which is practically ready for occupancy. Extensive additions to meet their expanding business have been added to this company's plant during the past two years, which has necessitated larger quarters for their executive staff.

The United Hammer Co., Boston, Mass., have purchased the power hammer business of E. & T. Fairbanks & Co., St. Johnsbury, Vt. The "Fairbanks" hammers were manufactured from 1890 to 1902 by the Dupont Mfg. Co., of St. Johnsbury, under the name "Dupont" hammers. In 1902 the business was taken over by E. & T. Fairbanks & Co., who changed the name to "Fairbanks" hammers, which title will be continued by the United Hammer Co.

Ontario Metal Output.—Increases in the total mineral output of the Province of Ontario, according to a report just issued by the Bureau of Mines, was valued at \$64,843,597, an increase over the preceding year of \$10,597,918. The report points out that the expansion in the production of minerals in this province was mainly confined to gold, nickel, copper, cobalt, molybdenum and lead. This was in large part a result of the war and consequent high prices for metals. The increase in valuation over 1915 is confined to metallic products, the total for non-metallies showing a small decrease.

Goodyear Tire and Rubber Co.—The new plant for the Goodyear Tire and Rubber Co., which is being constructed

at New Toronto, will be completed about May 1. The building is 560 feet long by 80 feet wide, four storeys and basement and will cost \$1,500,000. The stack is 14 ft. diameter and 250 ft. high. Approximately 600 men will be employed when the plant is opened, but the factory is large enough to employ 1,500 men. The Goodyear Company own 28 acres at New Toronto, and propose to build six factories of similar size as their business grows.

Brown's Copper & Brass Rolling Mills, Ltd., New Toronto, Ont., announce that they have awarded a contract to the Southwark Foundry & Machine Co., Philadelphia, Pa., covering the installation of a 2,000-ton hydraulic extrusion press equipment for the manufacture of brass rod. This machine will be in operation during the early part of May, and with their present equipment in their new rod mill will increase their output to over five million pounds of finished rod monthly. Their new mill for sheet metals will also be in full swing during May, 1917, increasing the output of their sheet mills to over five million pounds monthly.

Northern Navigation Co. Hold Meeting.—The three days' annual "Get Together" meeting which was held at the offices of the Northern Navigation Co., at Sarnia, Ont., was brought to a close on Friday. The men were gathered together for the purpose of discussing new methods and plans for the coming navigation season. A great benefit is derived by the different officials at a meeting of this kind exchanging views and offering suggestions for the good and welfare and popularizing this well-established line which conveys thousands of passengers and tourists on the Great Lakes every year. The prospects for a big season are very bright, and optimism permeated the meeting. The following officials were among those in attendance: H. H. Gildersleeve, general manager, Sarnia; W. H. Smith, agent of Owen Sound; C. H. J. Bowden, travelling freight and passenger agent, Montreal; W. L. Day, travelling passenger agent, Sarnia; Fred Bentley, chief clerk, Sarnia.

MARINE

Captains Appointed.—The Northern Navigation steams this year will be commanded by the following officers: Noronic, Capt. Foote; Harmonic, Capt. A. L. Campbell; Huronic, Capt. A. M. Wright; Germanic, Capt. F. G. Moles; and Waubic, Capt. John Dube. All the steamers are being fitted out and will start their schedule as soon as ice conditions will permit.

Montreal, Que.—It is expected that navigation will open about April 15. Officials of the Harbor Board predict that it will be considerably earlier this season than for some years past. April 15 is generally set as the date when the St. Lawrence channel will be sufficiently free from ice to permit of vessels coming into port. According to tests recently made, ice in the basin of the harbor is not more than four inches thick, and

this is said to indicate that the break up is not very far distant. According to pilots there is not ice at all between Quebec and Grondines, and that the ice is comparatively smooth from the latter point up to Montreal.

London, Ont.—Work will be undertaken within a few days, according to report, on the new \$130,000 Government pier at Port Stanley, to be constructed at the request of owners of the fishing fleet at the port and of the London and Port Stanley Railway Commission.

BUILDING

Montreal, Que.—Damage to the extent of \$3,000 was caused by a fire on March 13 in the warerooms of the Cassela Color Co., 59 William Street, which occupies the buildings recently vacated by the Canada Cold Storage Co., the owners.

Toronto, Ont.—Dr. C. J. O. Hastings has recommended to the Local Board of Health the erection of a hospital for infectious diseases, to cost \$75,000. The Board decided to hold a joint meeting with the Property Committee to consider the proposal to build on the western part of the jail grounds.

Mitchell, Ont.—The contract for the erection of the new agricultural building to replace the one burned down last fair day has been let. The contract price will be in the neighborhood of \$3,000. The building will be circular and 70 feet in diameter. Most of the material is now on the ground, and the building will be erected during the summer.

RAILWAYS—BRIDGES

Toronto, Ont.—Works Commissioner Harris is inserting in his estimates an item of \$200,000 for a new bridge across Rosedale ravine at Glen road. It is stated that this bridge will have to be constructed before the Bloor street viaduct is completed, in order to facilitate access to Howard street from the north.

INCORPORATIONS

Feldspar Quarries Ltd., has been incorporated at Toronto with a capital of \$40,000 to develop mines and quarries, etc. Head office at Toronto and provisional directors are Fred A. A. Campbell, D. B. Coleman and William Zimmerman all of Toronto.

Canadian Electric & Gas Heater Co., has been incorporated at Ottawa with a capital of \$250,000 to manufacture gas and electric stoves and heaters etc., at Montreal. Incorporators are C. J. E. Charbonneau, James E. Coulin and Philippe Morel all of Montreal.

The National Shipbuilding Co., has been incorporated at Ottawa with a capital of \$100,000 to carry on the business of iron founders, millwrights, machinists and shipbuilders at Goderich, Ont. The incorporators are W. H. Hutchinson of St. Catharines, Ont., Robert G. Stewart and Ernest A. Larnouth both of Ottawa, Ont.

ECONOMY No. 40 HEAVY DUTY, the EFFICIENT SHELL SAW

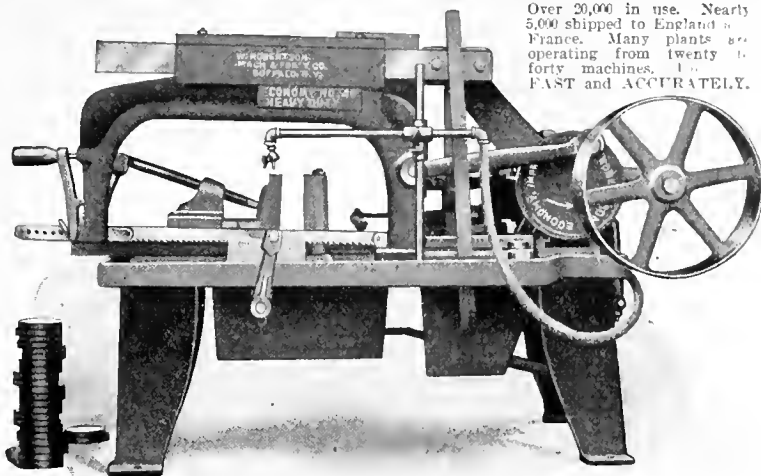

Over 20,000 in use. Nearly 5,000 shipped to England & France. Many plants operating from twenty to forty machines. **FAST and ACCURATELY.**

Draw Cut—Oil Compression Lift, relieving the blade on the return stroke. Frame cannot fall and break blades. Quick Acting Vise—Cut Gears—Friction Drive—Automatic Stop. Capacity 8 x 8". Takes blades from 10 to 17". This tool will give greater production at less cost than any tool in your plant. Economy Saws are built in sizes up to 8 x 18". **PROMPT DELIVERIES.**

W. Robertson Machine & Foundry Company, Buffalo, N.Y., U.S.A.

MORTON MANUFACTURING CO.
 PORTABLE PLANERS
 DRAW CUT SHAPERS
 SPECIAL DRAW CUT R.R. SHAPERS
 FINISHED MACHINE KEYS
 STATIONARY & PORTABLE KEY WAY CUTTERS
 SPECIAL LOCOMOTIVE CYLINDER PLANERS
OFFICE AND WORKS: MUSKEGON HEIGHTS U.S.A.

OVENS
 Enameling and Varnishing Ovens heated by Gas, Electricity, Steam or Coal
 Write for Booklet.
Brantford Oven & Rack Co., Ltd.
 Brantford, Canada.

"Barnes-made" SPRINGS

 are the result of over sixty years' experience in spring making, combined with unsurpassed equipment and the workmanship of men who have been with us, ten, twenty and in some cases thirty years.
 Write for booklet No. 7-C.
 Established 1857
THE WALLACE BARNES COMPANY
 218 South St., Bristol, Ct., U.S.A.
 Mfrs of "Barnes-made" Products
 Springs, Screws, Machine Products, Cold Rolled Steel and Wire

METAL STAMPINGS

 We are manufacturers of stamped parts for other manufacturers.
 We do any kind of sheet metal stamping that you require. Our improved presses and plating plant enable us to produce the finest quality of work in a surprisingly short time.
 We can finish steel stamping in Nickel, Brass or Copper.
 Send us a sample order.
W. H. BANFIELD & SONS
 372 Pape Avenue, Toronto, Can.

THE IRON WORKS LIMITED
 Successors to
 Owen Sound Iron Works
 Owen Sound, Ont.
 Engineers
 Boiler-makers
 Founders
 Machinists
 Tank Work
 Smoke Stacks,
 Grey Iron and
 Brass Castings,
 Special Machinery
 Made to Order

3 BIG REASONS WHY YOU NEED

PURO

(MADE IN CANADA)

1. Puro Sanitary Drinking Fountains will give you a better water supply cheaper.
2. Puro will cut your water bills 15% to 35%.
3. PURO will safeguard the health of your employes and raise the standard of efficiency.

Are not these reasons enough? Then why hesitate longer? PURO equipment is not expensive—the first cost is low and the up keep nothing. Easily attached; positively fool-proof. Let us make you a special proposition for a try-out in one of your departments. Write us now—to-day—giving us the number of men; an inquiry will cost you nothing.

“PURO - FY”

YOUR WATER SUPPLY

Puro Sanitary Drinking Fountain Company
143 University Ave.
TORONTO, CANADA

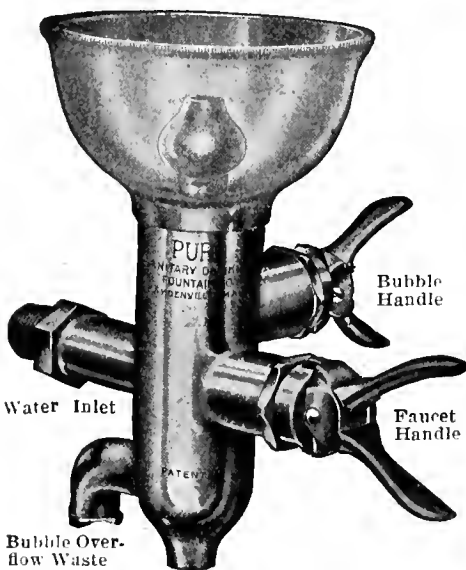

CATALOGUES

The American Pulley Co., Philadelphia, Pa., have issued a booklet entitled "Building 25," descriptive of a new building recently opened at the plant for the convenience of workmen and for safeguarding their health. The booklet contains descriptive matter, and also a series of photographic views showing the principal features of the building, embodying the latest ideas applied to the preservation of health in factories.

A. C. Generators.—T. W. Broadbent, Ltd., Huddersfield, England, have issued a new bulletin, No. 4, dealing with their T. Type three-phase generators, designed especially for motor driving. A full description is given of this machine, accompanied by illustrations, while a price list is included, giving capacity and weights for each size of generator and exciter. Copies of the bulletin may be obtained on application.

Water Heaters.—The Alberger multi-head water heater for hotels, office buildings and factories, is described in a Bulletin No. 201 recently issued by the Alberger Heater Co., Buffalo, N.Y. The principal constructional features of the multi-head heater and their advantages are described fully, special reference being made to the method used in the heater to accommodate unequal expansions. The bulletin is illustrated.

Row & Davis, Engineers, Inc., 90 West street, New York, have just published two interesting bulletins, copies of which will be mailed to readers on request. "The R. & D. Paracoil "Evaporator," Bulletin No. 51, for single or multiple effect operation. The bulletin shows and describes the evaporator thoroughly. The most interesting feature, perhaps, is the patented new type of manifold, which is mounted on a hinged door to facilitate inspection, cleaning, etc. Bulletin No. 52, "The R. & D. Feed Water Heater" fully describes the shell, manifolds, coils, connections and fittings of their heater. These bulletins should be in the hands of every engineer interested in feed water heating and water distillation.

Galt Sprinkler Stoker.—The Galt Foundry Co., Galt, Ont., have issued an attractive catalogue dealing with the economic and smokeless burning of coal, including lignite, and at the same time featuring the Galt sprinkler stoker. A full description is given of this type of stoker, and its principal feature dealt with in detail, accompanied by numerous illustrations showing the construction and application to various types of boiler. The concluding pages contain some useful engineering data covering evaporation formulae, heat values of coal, feed water calculations, miscellaneous tables, etc. The catalogue also contains instructions for reading the slide rule, accompanied by diagrams. The McNaughton rocking sectional grate bar is also described and illustrated. The catalogue is well gotten up, being printed on coated paper, with exceptionally clear half-tones.

Ball Bearings for Transmission.—The Chapman Double Ball Bearing Co., of Canada, Ltd., Toronto, have issued to the trade a new 48-page bulletin No. 107. This bulletin, which is a very attractive publication, illustrates and describes fully, a standard line of power transmission bearings. Among the illustrations are included a number of sectional views of bearings showing the principal features embodied in their design. The section of the bulletin devoted to the development of the Chapman double ball bearing contains much useful information covering the design and scientific features of this bearing, while details of tests are also included with views of the apparatus used for the tests. The application of ball bearings for loose pulleys and pillow blocks is also dealt with, fully accompanied by dimension tubes and price lists. One interesting feature comprises a number of excellent full page half-tones, showing a variety of power transmission installations equipped with the Chapman product, and also interior views of the company's plant.

BOOK REVIEW

"Combustion in the Fuel Bed of Hand-fired Furnaces." is the title of Technical Paper 137, by Henry Kreisinger and others, which has just been issued by the Bureau of Mines of the Department of the Interior, Washington, D.C. The main object of the investigation was to determine the conditions governing the process of combustion in the fuel bed of a hand fired furnace. The results of this investigation furnish data for correct design of coal-burning grates and furnaces and their efficient operation. They also cast light on the important problem of clinker trouble as related to fusibility of ash. They further indicate the possibility of a high rate of gasification of coal in gas producers. The first part contains general information on the combustion of coal in furnaces. The second part contains the description and the results of about fifty tests made in a small experimental hand-fired furnace, which was designed for an accurate study of the processes of combustion in the fuel bed. The third part discusses the investigations described in the second part of the report, and includes about forty charts that show the composition of the gases and the temperature at different depths in the fuel-bed of a hand-fired furnace, and various relations between the air supply and the rate of combustion. The fourth part contains miscellaneous data on the composition of gases rising from the fuel bed of a hand-fired furnace under a steam boiler, a Murphy stoker, and a Jones underfeed stoker. It also contains a short discussion of the bearing of the results of the experiments on the operation of gas producers and explosions in boiler furnaces. Copies of this technical paper may be obtained free of charge by addressing the Director of the Bureau of Mines, Washington, D.C.

"VERDUN"
Quick Opening
VICES

Plain Model
— Without
Ball Socket.
Universal
Model—With
Ball Socket.

For Bench and Machine-Tool Work.
They are:—
Rigid—Quick in Action—Reliable in Service.

WELBORNE & CO. (Machinery)
ou h Ferry Building, New York, U.S.A.

CANADIAN MACHINERY

AND MANUFACTURING NEWS

A weekly newspaper devoted to the machinery and manufacturing interests.

Vol. XVII.

TORONTO, MARCH 29, 1917

No. 13

EDITORIAL CONTENTS

Special Machine Tools Developed for Shrapnel Manufacture	305-308
General	308
<i>Shipbuilding Has Assured Future.</i>	
Production Methods and Devices	309-311
<i>Cutting Shells to Weight...Self-Locking Lifting Tongs...Making "Holden-Morgan"</i>	
<i>Thread Milling Cutters...Internal Chucking Devices...Re-centering Device for Shell</i>	
<i>Bases.</i>	
General	311
Pyrometer Development	312
Spokes in Industry's Wheel	313
<i>E. T. Spidy.</i>	
Guidance Specification for Triple Expansion Marine Engines for Cargo Boats	314-315
General	315
<i>Ontario Government Estimates...Ontario Nickel Deposits.</i>	
Power and Its Generation	316-319
<i>Steam Power Economics.</i>	
General	319
<i>British Specifications in Foreign Languages Development of Steel Castings</i>	
<i>Manufacture.</i>	
Processes in Manufacture	320-322
<i>Coating Iron and Steel With Zinc—Galvanizing...Good Business Organization.</i>	
Progress in New Equipment	323-324
<i>Heavy Duty Double Grinder Semi-Automatic Thread Milling Apparatus</i>	
<i>Hydraulic Joint Packing...New Form Shell.</i>	
Editorial	325
<i>Individuality or Co-operation...Standardizing Marine Engine Design.</i>	
Selected Market Quotations	326-327
The General Market Condition and Tendency	327-330
<i>Summary...Montreal Letter...Toronto Letter...Sydney Letter.</i>	
Industrial and Construction News (Advtg. Section)	62

THE MACLEAN PUBLISHING COMPANY, LIMITED

JOHN BAYNE MACLEAN, Pres. H. T. HUNTER, Vice-pres. H. V. TYRRELL, Gen. Man.

Publishers of Hardware and Metal, The Financial Post, MacLean's Magazine, Farmer's Magazine, Canadian Grocer, Dry Goods Review, Men's Wear Review, Printer and Publisher, Bookseller and Stationer, Canadian Machinery and Manufacturing News, The Power House, The Sanitary Engineer, Canadian Foundryman, Marine Engineering of Canada.

Cable Address: Macpubeo, Toronto; Atabek, London, Eng.

ESTABLISHED 1887.

CANADIAN MACHINERY

AND MANUFACTURING NEWS

PETER BAIN, M.E., Editor. B. G. NEWTON, Manager.
Associate Editors: A. G. WEBSTER, J. M. WILSON, J. H. RODGERS.

CHIEF OFFICES:

CANADA—Montreal, 701-702 Eastern Townships Building; Toronto, 143-153 University Ave., Telephone Main 7324; Winnipeg, 22 Royal Bank Building, Telephone Garry 2313.

GREAT BRITAIN—LONDON, The MacLean Company of Great Britain, Limited, 88 Fleet Street, E.C., E. J. Dodd, Director. Telephone Central 12200 Cable Address: Atabek, London, England.

UNITED STATES—New York, R. B. Hnestis, 115 Broadway, N.Y., Telephone Rector 8971; Boston, C. L. Morton, Room, 733, Old South Building, Telephone Main 1204, A. H. Byrne, 11015-6-7 Fort Dearborn Bldg., 105 W. Monroe St., Chicago, Telephone Randolph 3231.

SUBSCRIPTION PRICE—Canada, Great Britain, South Africa and the West Indies, \$3.00 a year; United States, \$3.50 a year; other countries, \$4.00 a year; Single Copies, 15 cents. Invariably in advance.

HENDEY 18-inch GEARED HEAD LATHE

8 mechanical changes of speed for spindle with driving shaft running at constant speed, 4 direct and 4 through back gears.

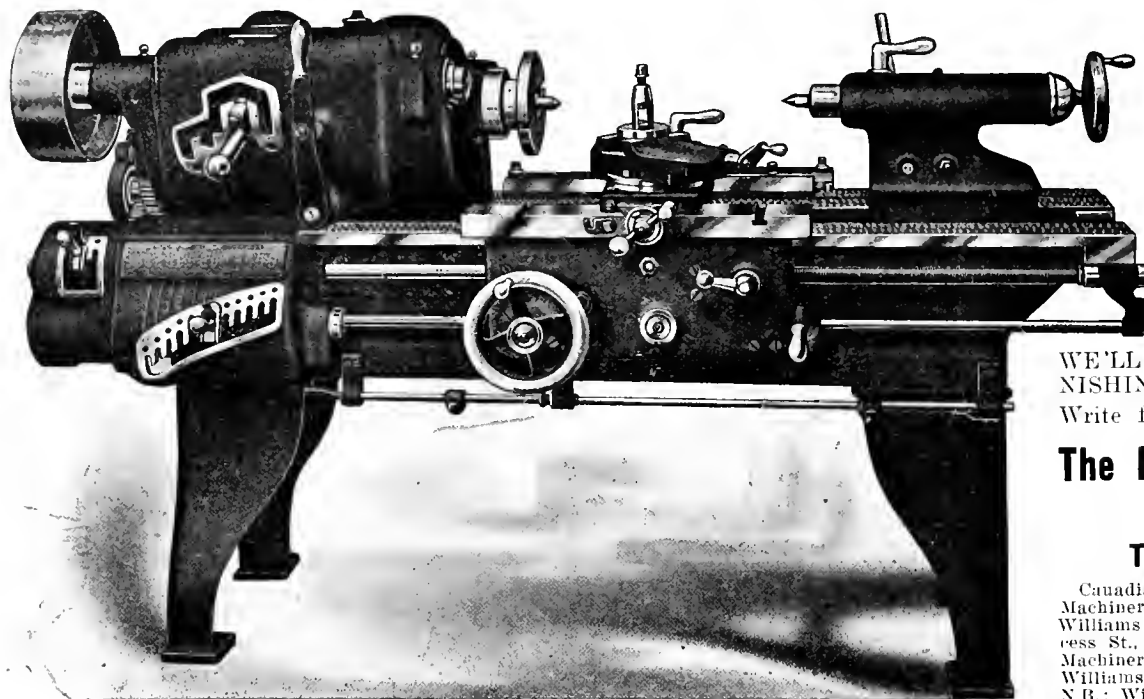

36 DIFFERENT THREADS AND FEEDS are had through Mounted Change Gearing, each change being quickly made through controlling handles in Gear Boxes.

BEFORE PURCHASING A NEW LATHE INVESTIGATE THE HENDEY SERVICE.

WE'LL HELP YOU BY FURNISHING LIST OF USERS. Write for descriptive circular.

The Hendey Machine Company

Torrington, Conn.

Canadian Agents: A. R. Williams Machinery Co., Toronto, Ont.; A. R. Williams Machinery Co., 260 Princess St., Winnipeg; A. R. Williams Machinery Co., Vancouver; A. R. Williams Machinery Co., St. John, N.B.; Williams & Wilson, Montreal.

INDEX TO ADVERTISERS

Albany Pump Co. 66	Delta File Works 64	Kei & Goolwan 67	Riverside Machy. Depot 72
Allen, John F., Co. 91	De Mooy Mach. Co. 117	Keystone Eng. Co. 24	Rivett, Lathe & Grinder Co. 126
Armstrong Bros. Tool Co. 85	Dept. of Finance 125	Kang, Ltd., Warden 28	Rockwell Co., W. S. 109
Atlas Whitworth of Canada 14	Duckow, Fred. C. 65	L'Air Liquid Society 82	Roelofson Machine & Tool Co. 17
Atkins, Wm., & Co., Ltd. 13	Dominion Belting Co., Ltd. 69	Laminating Machine Co. 24	Roper & Co., C. F. 88
Atlas Crucible Steel Co. 14	Dominion Bridge Co. 96	Lancashire Dynamo & Motor Co. 91	S
Atlas Press Co. 109	Dominion Machinery Co. 74, 119	Lanroc Electric Steel Co. 11	Scott Mach. Co., G. H. 89
Auroa Tool Works 119	Dominion Steel Foundry Co. 107	Lendon Lott & Lange Co. 63	Scott, F. H. 106
A	Drury Co., H. A. 7	Lynn Time & Supply Co. 9	Sauer Co., F. H. 109
B	E	M	Simmons Mach. Co., Inc. 78, 121
B. A. B. Mold Mfg. Co. 81	Eastern Mach. Screw Corp. 104	Mackinnon, Holmes & Co., Ltd. 69	Skinner Chuck Co. 107
Babeuck & Sons 66	Elmes, Chas. F. 28	Magnolia Metal Co. 96	Shoem, Avram & Shoem 121
Baird Machine Co. 110	Eric Foundry Co. 91	Wagon & Station 66	Shumley-General Co. 26
Banfield, E. J. 18	F	Manufacturers Equipment Co. 104	Smart-Turner Mach. Co. 29
Banfield, W. H., & Sons 67	Fairley, Davidson Steel Co. 8	Marsh & Henthorn, Ltd. 83	Smooth-On Mfg. Co. 85
Barnes, Wallace, Co. 69	Fetherstonhugh & Co. 66	Mathews, Jas. H., & Co., Inc. 169	Standard Alloys Co. 8
Baxter & Co., Ltd., J. R. 15	Fitzgald, W. H. J. 72	McAme, J. J. 32	Starratt Co., L. S. 93
Betmus & Call Hardware & Tool Co. 92	Fleck, Alexander, Limited 65	McCo's Brandt Machy. Co. 6	Steel Bending Brake Works, Ltd. 168
Bottam, John, & Sons Co., Ltd. 1	Ford Chain Block & Mfg. Co. 100	Metzger Co., H., Inside back cover	Steele, Ltd., James 65
Front cover and page 1	Press & Hill Machy. Co. 6	Metzger, The H. K. Machy. Co. 21	Stetcher Co., Chas. 106
Bertram's, Limited 65	Francis & Co. 109	Metcalf, J. C., Holding Co. 168	Steel Co. of Canada 3
Blake & Johnson Co. 119	G	Mechanical Engineering Co. 89	Stephens, John, Co. 15
Bliss, B. W., Co. 29	Gardner Machine Co. 123	Metalwork Mfg. Co. 28	Stirk & Sons, John 65
Bloom, J. G. 15	Garthoff, Robt., & Sons 79	Miller Snyde Electric Co. 71	Shucker-Humley-Wachs Co. 73
Braunford Owen & Rack Co. 67	Garlock-Walker Machy. Co. 75	Milnolant Co., W. K. 22	Shaw Mfg. Co. 30
Bridgford Mach. Tool Works 9	Garvin Machine Co. 22	Milton Mfg. Co. 66, 77	Swedish Steel & Importing Co. 9
Bristol Company 107	Geometric Tool Co. 61	Monarch Brass Mfg. Co. 81	T
Brown Engineering Corp. 79	Gibb Instrument Co. 89	Montgomery Smith & Co. 91	T. C. M. Mfg. Co. 20
Brown Machy. Co. 78	Gilbert & Barker Mfg. Co. 88	Montreal General Tool Co. 20	Tabor Mfg. Co. 168
Brown's Copper & Brass Rolling Mills 6	Grant Gear Works, Inc. 168	Montreal Machy. & Supplies 115	Talman Brass & Metal Co. 119
Budon, Hanbury A., & Co. 66	Grant Mfg. & Machine Co. 115	Morse Twist Drill & Mach. Co. 111	Taylor Instrument Co. 89
C	Greenfield Machine Co. 108	Morse Cham Co. 103	Taylor Machine & Tool Co. 29
Can. Bond Hanger & Co. 90	H	Modern Tool Co. 103	Toomey, Frank A. 74
Canada Machinery Corporation 98	Hall & Sons, J. H. 27	Morion Mfg. Co. 65	Toronto Iron Works 107
Canada Metal Co. 98	Hammant Car & Engine Works 91	Muir, Wm., & Co. 65	Toronto Testing Lab. 110
Canada Stiles Co. 102	Hamilton Gear & Machine Co. 98	Stinchey Machine & Tool Co. 105	Toronto Welding Co. 69
Can. B. K. Marlon Co. 87	Hamilton Machine Tool Works 23	N	U
Can. Fairbanks-Morse Co. 34	Hagan & Co., M. A. 9	National Machinery Co. 105	Union Drawn Steel Co. 109
Can. Billings & Spencer 91	Hawkrige Bros. 26	National Machine Tool Co. 140	United States Electrical Tool Co. 51
Can. Desmond-Stephan Mfg. Co. 106	Henley Machine Co. 128	New York Machinery Exchange 74	V
Can. Economic Lubricant Co. 99	High Speed Hammer Co. 106	Nicholson File Co. 92	Vanadium Alloys Steel 12
Can. Ingersoll-Rand Co., Ltd. 33	Hinold Mach. Co. 165	Niles-Rennett-Pond, Inside front cover	Victor Saw Works 27
Can. Inspection & Testing Laboratories, Ltd. 107	Hobbs, John T. 19	Northern Crane Works, Inside front cover	Victor Tool Co. 104
Can. Matthews Gravity Center Co. 67	Hollander Melby Co. 71	Norlon, A. O. 31	Vulcan Crucible Steel Co. 11
Can. Metal Products 86	Hoy, Metal Co. 110	Norlon Co. 31	W
Can. Marshall Mfg. Co. 86	Hull Iron & Steel Filings, Ltd. 84	Nova Scotia Steel & Coal Co. 12	Walls Supply Co., T. P. 121
Can. Steel Foundries, Ltd. 7	Hunter Saw & Machine Co. 24	O	Walcott Lathe Co. 27
Carlyle Johnson Mach. Co. 101	Hungate Brass & Copper Co. 86	Ontario Specialties, Ltd. 166	Warner & Swasey Co. 21
Catapan Refining Co. 84	Humbert Regen, Machinery Co. 25	Oven Equipment & Mfg. Co. 83	Webber Bros. Mach. Co. 83
Chapman Double Ball Bearing Co. 98	Hyd. Engineering Works 105	Otley Machy. Co. 16	Wells Bros. Co., of Canada 32
Chesherman, Jas., & Co., Ltd. 116	I	Osborne & Sexton Melby Co. 4	Whipple & Choate 82
Cincinnati Pulley Machy. Co. 117	Ideal Tool & Mfg. Co. 103	P	Whitting Foundry Equipment Co. 106
Cleveland Wire Spring Co. 65	Independent Pneumatic Tool Co. 31	Parmerter & Bulloch Co. 108	Whitman & Barnes Mfg. Co. 94
Cleveland Pneumatic Tool Co. 33	Iron Works, The 68	Perrin, Wm. R. 29	Whitney Mfg. Co. 61
Clippard Belt Lacer Co. 99	J	Peerless Machine Co. 25	Williams, A. H., Machinery Co. 17
Colonial Steel Co. 109	Jacobs Mfg. Co. 102	Petrie, H. W., Ltd. 71	Wicks, Bus. 16
Cook, Asa S. 169	Jandrie Co., A. R. 117	Philadelphia Gear Works 65	Williams, J. H., & Co. 85
Cullen Machy. Co., C. W. 72	Jardine Machy. Co. 72	Phillipsville Foundry 79	Windsor Mach. & Tool Works 11
Cummings & Son, Ltd., J. W. 88	Johnson Mach. Co., Carlyle 101	Positive Catch & Pulley Works 108	Winnipeg Gear & Engineering Co. 79
Cushman Chuck Co. 107	Jones & Glasco 99	Pratt & Whitney, Inside front cover	North Engineering Co. 69
D	Jersey City, Mach. Co. 109	Pringle, R. E. T., Ltd. 33	Z
Davis Brownsville Co. 178	K	Pritchard-Andrews Co., of Ottawa. 92	Zenith Coal & Steel Products Co. 108
Davis, W. F., Machine Tool Co. 73	Kasent, Limited 15	Puro Sanitary Drink Fountain Co. 68	Zin-Ho Mfg. Co. 30
Deloro Smelting & Refining Co. 4	Kennedy, Wm., & Sons 28	R	
		Racine Tool & Machine Co. 25	
		Rhodes Mfg. Co. 113	

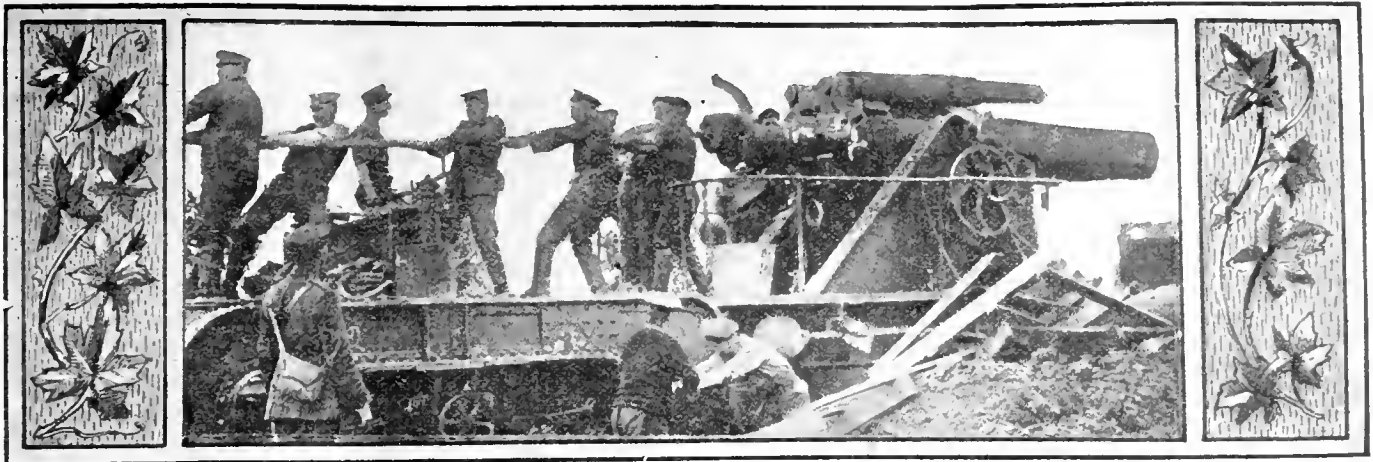

PREPARING A LARGE SIEGE GUN FOR ANOTHER ROUND ON THE WESTERN FRONT.

Special Machine Tools Developed for Shrapnel Manufacture

Contributed

Special interest attaches to the machines described in the accompanying article in view of the fact that they are the product of actual experience in shell machining. Previous to undertaking shell work, the concern building these machines was engaged on work widely different from machine tool building, which thereby enhances its reputation as a shell producer.

THE manufacture of shrapnel shell, by reason of the light weight and small dimensions, lends itself very readily to the use of single purpose machines, and the degree to which operations have been simplified and the possibility of error removed has been one of the principal factors contributing to the successful carrying out of large scale shell production. A detailed tracing of the work during progress is also essential in work of this class, and the illustrations which

shell work as well as shrapnel, while nearly every type of machine can be utilized as a unit in an existing shell system, so that users of other types of machines can select such of the Symington machines as fit into their present outfit. This elasticity is a desirable feature and is obviously preferable to a system where the rotation of operations is dependent on the procuring of a large number of different machines more or less dependent on each other for successful production.

into the spindle the proper distance. A spring plunger is provided in the spindle which keeps the shell against the gauge rod, while the chuck is being tightened up. The cross slide has power feed with automatic trip.

Nick-Centering

The open end is now nick-centered on a simple type of drop stamp, the object

Progress Report

The progress report sheet reproduced is to a great extent self-explanatory. It will be noted that in "Type" column, the only equipment not indicated as Symington designs are furnaces, press, marker and drill. Fig. 1 shows a double ring wheel grinder of simplest possible design, for squaring before either cutting-off the open end or centering. The forging is held in a vee-block by hand and the table swings across the face of ring wheel which grinds off the portion of the base required for centering. Mention might be made of the stop bars for limiting the swing of the table, thus preventing the shell from passing clear of the face and being inadvertently pushed along the vee-block so as to foul the outside of wheel on the return stroke. The ring wheel chucks have a diameter of 12 in.

The cutting-off machine is designed for all types of 3 in. shells and consists of a unit type bed similar to that shown in Fig. 9, with suitable tool carriage and gauge rod device. The hinge chuck has three inserted jaws ground to diameter of shell forging. The point of cutting-off is gauged from the bottom of the bore by a gauge rod sliding in a bracket fitted with a spring stop pin which engages with a slot in the rod when the shell is pushed

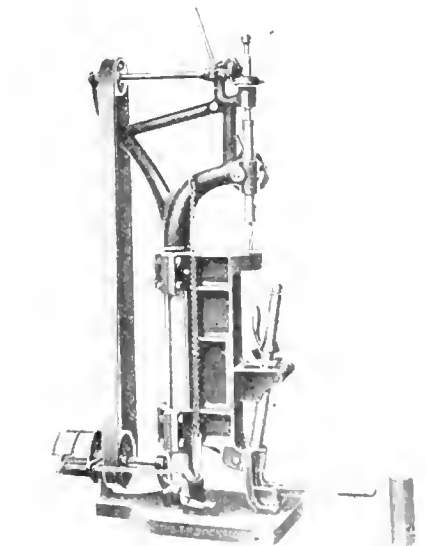

FIG. 2. CENTERING MACHINE WITH TILTING, EXPANDING ARBOR.

being to produce a series of nicks around the inside edge of the mouth to fit the spur drive centre used on the rough turning lathe, Fig. 4. The anvil of the stamp is provided with an arbor for supporting the shell, and a solid block is inserted around its base with chisel points which form the nicks when the die block is dropped on the closed end of the shell.

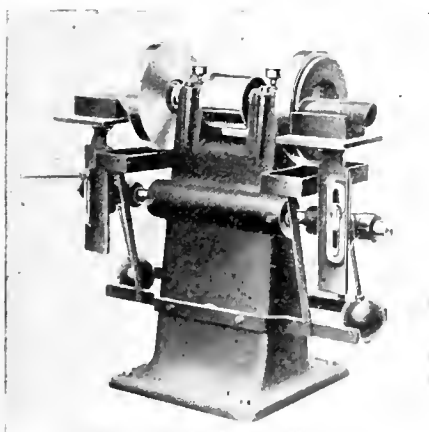

FIG. 1. DOUBLE RING WHEEL GRINDER FOR SQUARING BASES.

we reproduce herewith will enable the salient features of such work to be easily grasped by readers familiar with shell manufacture. The machines are the product of the T. H. Symington Co., Rochester, N.Y., and have been developed under actual production conditions, in a factory having a capacity of 15,000 finished shell and sockets per day.

Single-purpose machines to the number of about twenty are available, several of them being adapted for high explosive

These nicks provide a very powerful means of driving the blank and enable the shell to be turned complete from base to nose without interference from chucks, drivers, etc.

The machine shown in Fig. 2 centers the closed end by drilling in the usual way. A swinging arbor with expanding jaws at the point is operated by a foot

the spur drive centre being clearly shown. A single tool block is provided in front, and the carriage operates on a flat profile cam to turn different shell diameters, a powerful spring holding carriage up to cam. The carriage is further equipped with a cam relief for returning the carriage to starting point without seeing the work. A similar machine, type B-1

same design of bed is used for this machine as in the rough turning lathe, the spur drive centre being replaced with a hinge chuck while the tailstock is removed. The inserted tool steel jaws are ground to shell specifications, and the carriage is fitted with power feed having automatic trip. Where shells are bored taper, the cross-slide is arranged to work against a profile cam on the back of the machine, thus boring the shell to profile. The bar is equipped with cutting tools for machining the bore, and is slotted on one side and a copper tube sweated in for conveying the lubricant directly on to the tool point. A similar machine having the power feeds replaced by a fine hand-worm feed is used for roughing the powder pocket.

Inside Finishing

Inside finishing is done with machine type B-2, Fig. 6, which is fitted with a triple tool cross slide which can be tooled up to any particular specification of shell: for instance, the first tool hole can be connected up for form boring and for this work the cross slide is guided by a hardened roll held against a profile cam by a heavy spring back of the machine. For finishing the bottom or powder pocket of the shell, which requires a heavy pressure, a powerful hand worm feed is attached to turret carriage which makes this operation easy. The shell blank is gauged from the open end by a stop in the chuck guard and a spring plunger inside of the spindle. Rough facing of the base is done in the same machine as is used for cutting-off, the tool holder being changed to suit requirements.

Operations from No. 10 to No. 17 may be performed in suitable equipment which happens to be available, although in the case of large productions such as are obtained by the Symington Company the operations of heat treating and nose closing is handled on an exceptionally large scale which permits the use of furnaces and handling arrangements not commercially feasible with small plants.

Nose Finishing

The machining of the nose includes boring, reaming, tapping and undercutting, and is done on a similar machine to that used for finishing the interior. The shell is held in a four-jaw spring chuck with open end facing the tools. The carriage is equipped with hand feeds only and has a cross slide with four tool holes bored to 1 3/4 in. dia. This slide is indexed with pin to locate holes centrally with spindle, and is customarily fitted up with tools for rough boring, finish boring, tapping and undercutting, also for form boring on interior profile of nose.

The finish turning of the shell is done complete, including the profile. The threaded nose has a socket screwed in which fits the screw drive in the spindle nose. The centre which is still in the bottom of the shell is supported by the tail stock. A profile cam controls the travel of the tool which starts at the base end of the shell and travels the full length of the shell right to the nose. A cam relief is equipped for returning the car-

**PROGRESS REPORT
ENGLISH 18-Pdr. SHRAPNEL**

				Date	191			
TYPE	MACH. REQ.	MACH. IN SHOP	MACH. IN PRG. RM.	OPERATION	GOOD	CO. S. LOSS	DEF. FORG.	OPEN LOSS
X-3				1 Spot Face	3000	15	30	
A-1				2 Cut Off				
W-1				3 Center Open End				
X-1				4 Center Closed End				
B-8				5 Rough Turn				
B-30				6A Rough Inside				
B-2				6 Finish Inside				
B-2				6B Rough and Finish Inside				
				7 Bump Fit				
A-2				8 Face Closed End				
				8A Stamp				
				9 Change on Head and Nose				
Turnace				10 Heat Treat				
Turnace				11 Turn				
				12 Drawback				
				13 Lead Bath				
				14 Turn on Nose				
Press X				15 Close in Nose				
				16 Anneal Nose				
X-2				17 Re-center				
B-3				18 Bore, Ream and Tap Nose <i>undercut</i>				
B-3				19 Hand Tap Shell				
				20 Wash and Grease				
B-8-S				21 Finish Turn				
G-1				22 Grind Bourrelet				
B-40				23 Remove Center				
A-2-S				24 Finish Face				
				24A Stamp				
Marker X				25 Mark				
A-6				26 Form Tool Base End				
				26A Turn Head				
A-3				27 Wave and Undercut				
A-4-S				28 Fishg Burs				
Vent				29 Ventilate Wave				
				30 Remove Turn Copper Bands				
				31 First Inspection				
				32 Cut Off Copper Bands <i>from tube</i>				
				33 Burning Copper Bands				
				34 Annealing Copper Bands				
W. T. X				35 Press on Copper Bands				
A-4				36 Finish Turn Copper Bands				
				36A Rough Turn Copper Bands				
				37 Final Inspection				
				38 Oil and Pack				
				40 Salvage				
B-20				51 Finish Inside				
Drill				52 Drill Grub Screw Hole				
				53 Hand Tap Inside				
A-20				54 Finish Outside				
A-20-S				55 Hand Die Inside				
				56 Remove Copper Bands				

Fuse Sockets Finished To-Day

	SUBMITTED	ACCEPTED	REJECTED	CONDEMNED
Insp. Powder Pocket	1,000	950	25	25 Total 1,015
First Inspection				
Final Inspection				
Fuse Sockets Finished in Stock				
Shipped To-Day				Forgings on Hand
Shipped to Date				Fuse Socket Forgings on Hand
Shipped this Month				Finished Fuse Sockets on Hand
Ready to Ship				Copper Bands on Hand
				Diaphragms on Hand

lever which thus centres the base of the shell from the inside, while the open mouth is centered on a conical collar. This machine is sometimes used for spot facing the closed end instead of grinding on the ring wheel grinder.

Turning the Body

Shell turning lathe type B-8 is shown in Fig. 4. The shell is held in centres,

is equipped with 3/4 in. square tools front and back, the front tool taking the greater part of the cut, and the back one following about 1/8 in. behind with a light cut; this machine, however, produces a parallel shell only.

The machine shown in Fig. 5 is designed for boring the inside body of the shell down to the diaphragm seat. The

riage to starting point without scoring the work.

A Cylindrical Grinder

Convincing evidence of the complete-

chine with long bed as in type B machines is used. A hinge chuck for the shell is mounted on the carriage in line with the spindle. The spindle carries a bar

In waving and undercutting, the shell is held in hinge chuck with a spring stop in the spindle, see Fig. 9. The shell is pushed in against this spring stop, and a

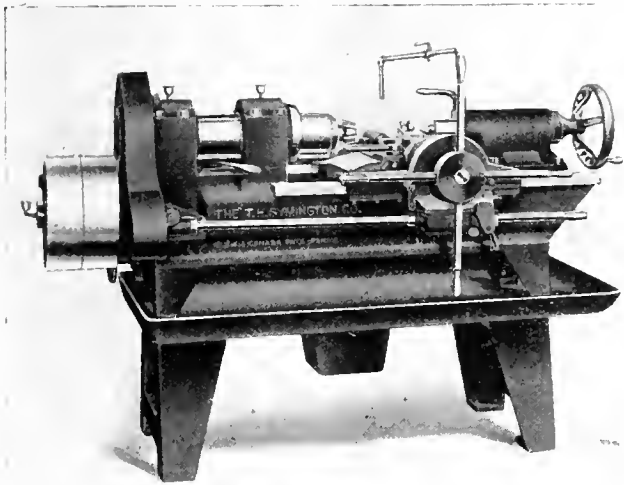

FIG. 4. ROUGH TURNING LATHE WITH SPUR DRIVE CENTRE AND PROFILE CAM.

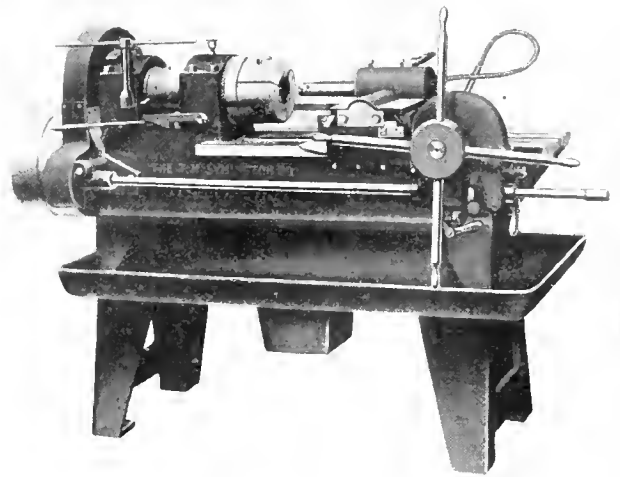

FIG. 5. SHELL BORING MACHINE WHICH CAN BE ARRANGED FOR TAPER WORK.

ness of the line of machines and the versatility of the designers is afforded by the grinding machine illustrated in Fig. 8, which is for grinding the bourelet or forward land in Russian shells and such outside diameters as are required in other types. This machine is equipped with hand feed only to the table, which is provided with three stops for three different diameters of finished body. Drive is direct from the line shaft by mounting a clutch with extended sleeve for holding the cone pulley which gives two speeds to the wheel head. The work-head drum is also driven direct from the line shaft and has a clutch so that work can be stopped and examined without stopping overhead works. Tailstock is equipped for holding the diamond for truing the face of the wheel. Size of wheel used is 18 in. x 2 in. x 5 in., and runs in bearings

which holds a high-speed steel cutter and also a stop pin arranged to operate when the fit has been completely removed.

Grooving, Waving, Etc.

Groove operations are divided over two machines of the A type, one of which does rough grooving and forms radius on corner of base, while the other, Fig. 9, waves and undercuts. The main features of these machines are identical, being of the short bed or chucking type as compared with the B type which has a long bed for using a tailstock or turret carriage.

In roughing the groove, the front tool block holds a circular form tool, the hand wheel to cross slide being indexed for depth of groove, and a fine hand worm feed for increased leverage fitted to feed serew. The radius tool is of circular

swing stop on the slide is thrown across the base of the shell, thus locating it in its proper relation to the waving and undercutting tools. The spindle is equipped with a circular wave cam in front of the front bearing. The wave slide works at right angles to the cross slide, and the cross slide hand wheel is graduated for depth of cut of wave ribs. Cross slide is equipped with fine hand worm feed to give leverage to the operation.

Undercutting Tools

The undercut bracket is located on the front of the cross slide and the angle of the bracket is machined to the angle of the undercut of the shell. Both right and left hand undercut brackets are fitted with small slides with adjustable gibs for wear, also with small hand wheels indexed for depth of cut. Flat stock is

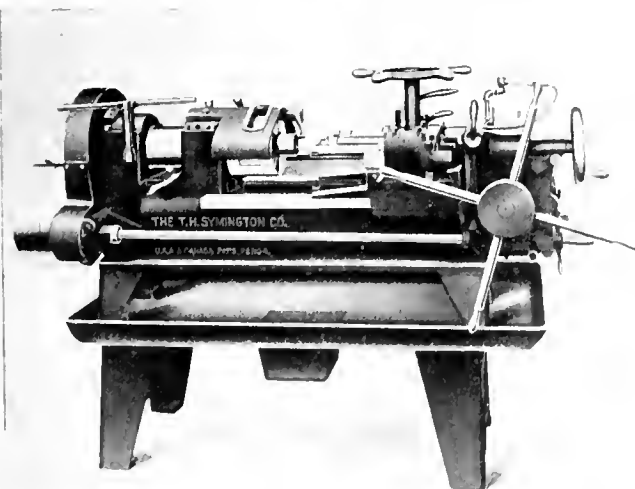

FIG. 6. TRIPLE TOOL BORING LATHE FOR FINISHING INTERIOR OF SHELL.

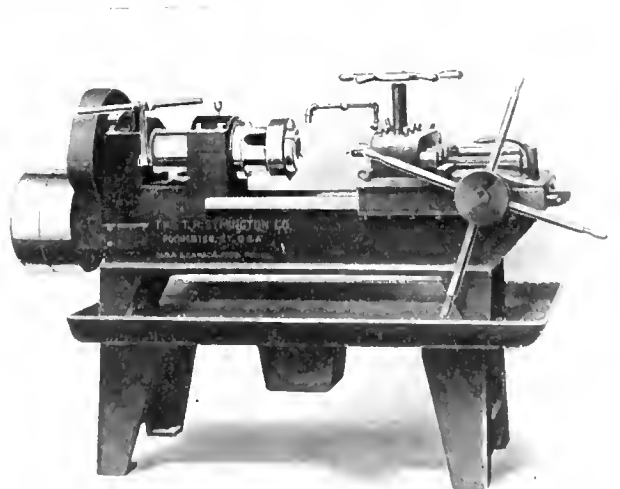

FIG. 7. FOUR TOOL MACHINE FOR MACHINING AND FINISHING THE INTERIOR

of the taper cone type made of special alloy bronze.

For removing driving centres or tits from the base after boring and finish turning operations are completed, a ma-

form, and is held in a swing fixture to allow for maximum and minimum thickness of base and also allow for slight variations in concentricity of base of shell.

used for the undercut tools. Provision is made for using either flat or circular form wave tools, and the wave cam slide, when undercutting, is relieved from the cam to prevent vibration.

Band Turning

The next operation which directly concerns these machines is the copper band turning done in type A-4 machine. The shell is held by the base in a collet chuck, while the nose is supported by a cup centre in a tailstock bracket. The turning tool is located on the back of the cross slide and is pulled underneath the shell, turning the band to its proper dimensions. On front of slide is a small hand-steady rest for supporting the hand tool with which the operator trims off the burrs from both edges of the band.

The machines illustrated and described herewith are good examples of their kind, and considered as a whole are brimful of suggestion and adaptation for other lines of manufacture. Attention has already been drawn to the fact that two main types have been developed, each of which has been utilized for many operations of

report is that a defective or worthless shell rarely gets to the inspection department. The inspectors who have charge of the batteries of machines on different operations, find it possible to discover defects in time, either to discard them or to divert them to the salvage department.



SHIPBUILDING HAS ASSURED FUTURE

THE future of shipbuilding in Canada has been the subject of much consideration by the Minister of Trade and Commerce, and has been discussed in more than one private conference during the past few months. Looked at superficially, the recent orders for wooden and steel ships aggregating sixty million dollars for Canadian yards promises a permanent revival of the industry. In that, sixty millions is included the Imperial

Canadian competitor could anticipate a forty per cent. handicap when Britain starts looking for orders. The only offset yet suggested is a form of subsidy, and it is a question whether the Dominion Government will proceed to nurture an infant industry under these unusual conditions.

Canada's shipbuilding industry has not made steady advances during the past fifteen years. Between 1901 and 1913—years clear of war conditions—the tonnage built and registered in Canada varied from 30,000 to 50,000, and in 1908 attained 78,000; in the 1915 fiscal year an advance was made to 55,000, and in that year too the tonnage sold to other countries ran to 1,150,000, as against averages of less than 200,000 in the fourteen preceding years.

The prospects of uninterrupted development on the Great Lakes are much

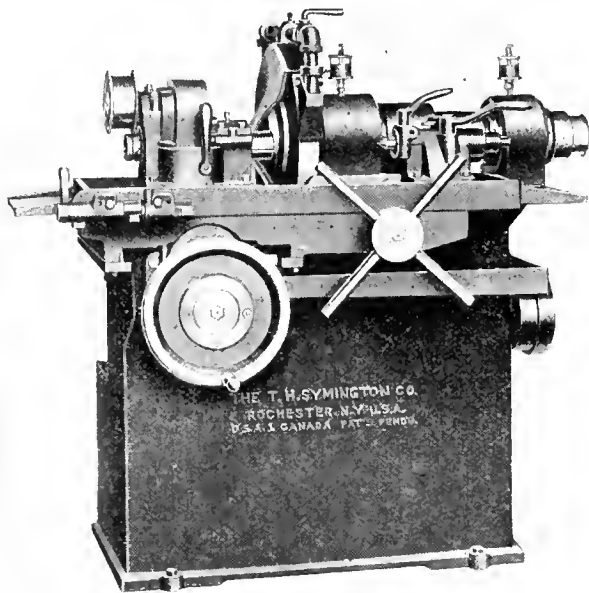

FIG. 8. PLAIN GRINDING MACHINE FOR SHELL BODIES, WITH THREE STOPS FOR BODY DIAMETERS.

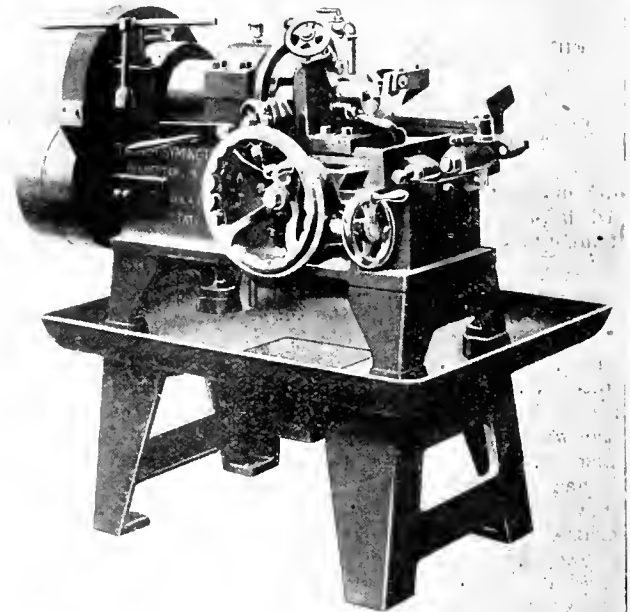

FIG. 9. GROOVING MACHINE WHICH GROOVES, WAVES, AND UNDERCUTS COMPLETE.

widely varying character. The desirable features of this from a manufacturing standpoint are very considerable, allowing of the larger parts being machined up to quite an advanced stage, after which various combinations of standard parts, shafts, feed gears, carriages and chucks, enable rapid assembly to be made for particular shell specifications.

Salvage Operations

At the bottom of the report is another form showing number of fuse sockets finished daily—number submitted for inspection, number accepted, number rejected, and number condemned. Only those condemned are a total loss. Those rejected are sent to what is known as a salvage department, from which they are returned as soon as the defect is remedied. The same plan is adopted with shells under the heading of Operators' Loss. One great advantage of such a

Munitions Board orders for twenty-five million dollars worth of steel ships, for which extensive plans are being worked out. More than one hundred wooden vessels are said to be planned for on the Pacific and Atlantic coasts, and there is a fairly good hint of efforts to adapt some of our steel making facilities to the work of rolling ship plates and fabricating structural steel of many kinds.

A leading shipbuilder, reviewing the situation, expressed the opinion that while the Imperial Munitions Board may stimulate steel construction for some years to make up for the heavy inroads of the German subs, the Canadian shipbuilding industry, freed from special support of that kind, faces an unpropitious market. Before the war, the British shipyards could produce at thirty per cent. less than Canadian yards. With the speeding up of British methods and the standardization of craft construction, the

better by reason of the protection of the canals from overseas competition in most lines. Whether the wooden ships now being constructed on the Pacific and Atlantic seaboard with high wages and costly materials can withstand the rivalry of British shipyards is a question inviting many sorts of opinion.



Neither Taking Risks.—A tall, gaunt-looking man entered a hotel and applied for a room. The price he was willing to pay entitled him to lodgings on the top floor of the house. Among his belongings the landlord noticed a coil of rope. He asked what the rope was for, and the man replied:—"That's a fire escape. I always carry it with me, and in case of fire I let myself down from the window." "Yes," replied the landlord, stroking his chin reflectively, "seems a pretty good idea, but guests with fire escapes pay in advance at this hotel!"

PRODUCTION METHODS AND DEVICES

A Department for the Interchange and Distribution of Shop and Office Data and Ideas Evolved from Actual Practical Application and Experience

CUTTING SHELLS TO WEIGHT

By R. Hamilton

ONE of the chief essentials in shell manufacture is the necessity of keeping the semi-finished product to the specified weight, so that, when finished, it will be between the high and low limit tolerances. It is a common practice to face metal from the base,

attached to the lathe, the arc is graduated. To do this, a $\frac{1}{4}$ inch block is used. It is first placed between the cutting tools and the face of a shell held in the chuck, with the pointer I bearing against the right hand pin H. The $\frac{1}{4}$ inch block is then removed and the tools advanced to the work; this causing the pointer to travel forward. When the

very satisfactory and highly efficient. Location of the shell in the chuck is not essential, as the device works independently and accurately for each shell operated on. Variation after facing does not exceed $\frac{1}{4}$ of an ounce of the desired weight.

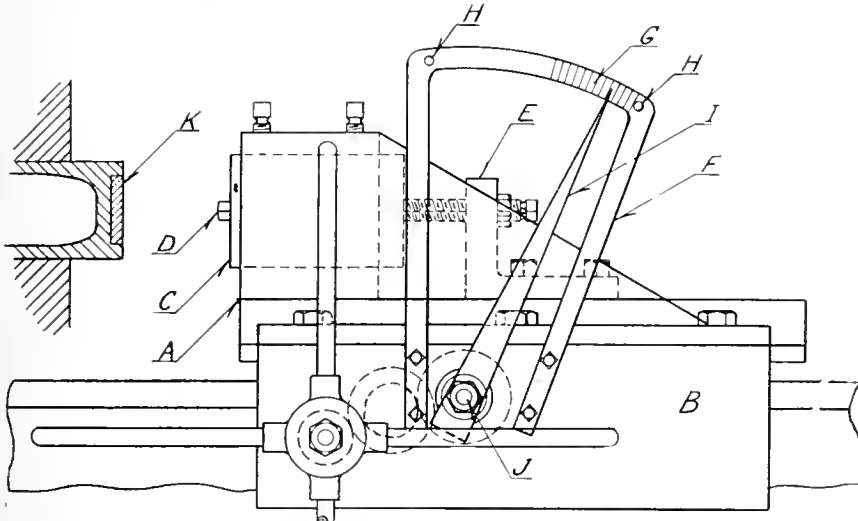

CUTTING SHELLS TO WEIGHT.

after the adapters are riveted in, to bring the shell to the required weight. As an ounce, or fraction thereof, may only represent about a 1-64 inch, it is very often difficult to gauge the exact amount when removing the metal. In a plant recently visited by the writer there has however been devised a simple but very effective method of meeting the requirement, and one that has entirely eliminated such trouble as may have been previously experienced. The accompanying sketch shows in detail the arrangement of the device.

The movable slide A, which travels in the fixed saddle B, carries the tool block C; the broad nose facing tools D being adjusted to position by means of the two rear screws, passing through an angle bracket E, which is secured to the movable slide. Bolted to the fixed saddle B, and extending upwards for about 18 inches, is the inverted U shaped piece F made of band irons with the arc graduated as shown at G, the pins H acting as stops at either end for the indicating finger I. This pointer is not rigidly secured to the shaft J, but operates between two leather washers, the friction being sufficient to allow finger to revolve in unison with the shaft J, when pointer is in a position between the two pins. The travel of the indicating pointer will have a certain relation to the movement of that of the tool slide; the variation depending on the operating gears and the distance of the indicating point from the center of motion. After the fixture has been at-

tools are in contact with the face of the shell, the position of the pointer is marked on the arc of the piece F. By subdividing this distance, graduations can be made so that the calculations are very accurate. Suppose the distance travelled by the pointer should be 4 inches, for a $\frac{1}{4}$ inch movement of the tool slide, this would be in the ratio of 16 to 1; therefore, each $\frac{1}{4}$ inch graduation would represent a tool movement of 1-64 inch. On a 4.5 inch shell, this amount of stock on the base would correspond to a weight of one ounce. It will be readily apparent from the foregoing that the device will operate very accurately.

When operating, a shell is weighed and the amount to be removed (in ounces) is marked on the shell. After the shell has been secured in the chuck, the lathe is started and the tools advanced. When the tools come in contact with the work, the pointer is pushed against the right hand pin, and, as the stock is cut off, the pointer will advance along the graduated arc to the desired position. This arrangement has proven

SELF LOCKING LIFTING TONGS

By J. H. R.

THE sketch herewith shows an inexpensive but serviceable lifting tong for 8 inch shell. In order to avoid the possibility of a shell slipping out of the tongs after it had been raised from the floor, it is very desirable that means be provided to lock it in a fixed position with a firm grip, as a knock in transit might dislodge it from the tongs. The rough bore of the forged claw is made quite free for the diameter of shell, and, through the central slot in the top the link is pivoted. When the horse-shoe claw is placed over the end of the shell and the weight raised, the action of the link will cause the tail end to press upon the upper portion of the shell body, thus holding it securely between the three points as shown. The simpleness of this device is one of its chief advantages.

MAKING HOLDEN-MORGAN THREAD MILLING CUTTERS

By Donald A. Baker

SOME time ago we found it impossible to get deliveries on thread milling cut-

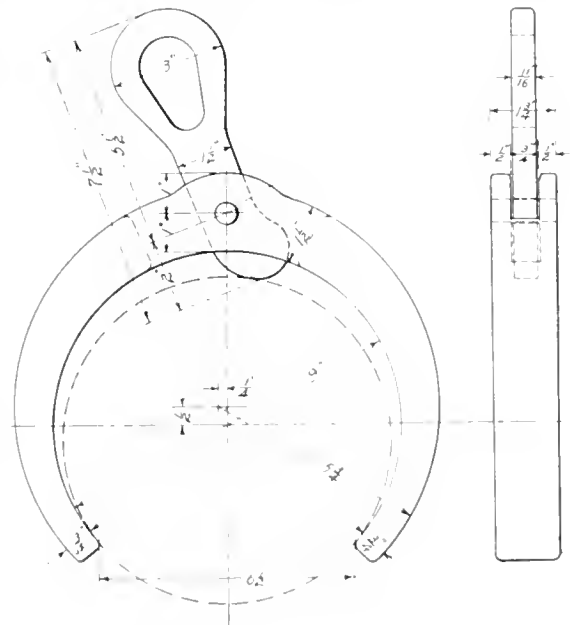

SELF LOCKING LIFTING TONGS

ters which we were using for cutting the base thread on time fuse bodies. These cutters are usually made up from a machine steel ring with carbon steel chasers welded on to the face of it. This of course was out of the question for us with our facilities so other means had to

be devised to meet the emergency as described herewith.

First a machine steel ring A, was turned up to the correct size. In this ring was shaped and milled the slots represented by B, ten in number, to receive chasers. These latter were made of high speed steel and have been found to work much better than the carbon steel ones usually supplied by the makers. Alongside of each slot a hole was drilled and reamed to receive a taper pin C. After these were reamed, the ring was again set up in the miller and a saw slot put down through the center of each of the taper holes as shown by D. The object of this being that when the chasers, one of which is shown by E are put in place the taper pin C can be driven in and the metal of which the holding ring is made will be forced against the chaser thereby holding it in place.

Making the chasers was the most difficult and particular part of the work. Stock for these was cut off just long enough to make four chasers from a piece, this being a convenient length for holding in our milling machine vise. This stock was $\frac{3}{8}$ in. square high speed steel. After milling to size on all edges

these be interchangeable to within very small limits. With the jig in place on the miller the chasers were milled one after the other. The chaser being fed up to the cutter, rather than the cutter being fed across the chasers, this being done to get a circular clearance back of the cutting edges rather than a straight clearance. This clearance was approximately six degrees.

It might further be stated that when trying out the first experimental cutter it was found that the hammer-like action of the chasers striking on the work was found to have a tendency to loosen up and drive back the chasers, some times leaving only one or two of the more solid ones to do all the work and thereby causing considerable chatter. To overcome this we have since made up our cutters, indicating the chasers with a dial indicator to make sure that they ran true, setting up in the grinder we have ground the back ends of each of the chaser teeth flush with the holding ring, then to back up and make sure that they could not drive back we turned up half inch thick machine steel rings and forced them on over the holding ring so that the chasers butted against them. Since then we have had no trouble and find that our home-made cutters will

ufacture. The importance of this factor was impressed upon shell makers from the very beginning of that industry, and many methods have been devised to procure accomplishment. When roughing operations are being performed the necessity of accuracy is not so pronounced, as errors can be rectified on subsequent operations, but, when machining to finished dimensions, the chucking must be done in such a way as to reduce the eccentricity to the lowest possible degree. Owing to the small space that is permitted in which to grip the shells from the inner surface, the construction of the chucking device must receive the closest attention, both as regards design and operation, to provide accurate and positive manipulation. The stress that is placed upon these driving mediums, more especially on the heavier shells, is often very great, and, in addition to the driving feature, it is also important that the device should be rigid enough to withstand the torsional strain of the cut.

The sketches herewith illustrate two different types of internal chucks designed for and used on the 8-inch shell. The one shown in Fig. 1 is operated directly adjacent to the shell base, while that in Fig. 2 is operated by means of a hand wheel at the rear of the spindle. In Fig. 1, the expanding arbor A, has a tapered shank that fits into the nose of the lathe spindle; this arbor being secured in a permanent position by means of a dowel, not shown. The operating sleeve C has a notched collar, the outside diameter of which is turned a shade smaller than the finished size of the shell body to allow of the cutting tools passing entirely over the outer surface of the shell, without disturbing the operating sleeve. At three equi-distant points in the shell of the sleeves are cut slots to receive the hardened steel jaws D which are kept in contact with the uniform cam on the outer end of the expanding arbor by

the action of the ring spring B. After the parts are assembled, they are retained in position by the small plate F secured to the face of the arbor. The design of these chucks is such as to increase the holding qualities should the shell develop a tendency to slip, under the pressure of the cut.

The action of the chuck shown in Fig. 2 is somewhat similar to that just described, but the design is much different. The operation of the expanding arbor is controlled by means of the hand wheel located at the rear end of the lathe spindle. Keyed to the end of the connecting rod A is the steel bush B, on the outer diameter of which are two notches H. The operating hand wheel C is bored out to fit the collar B, and is retained

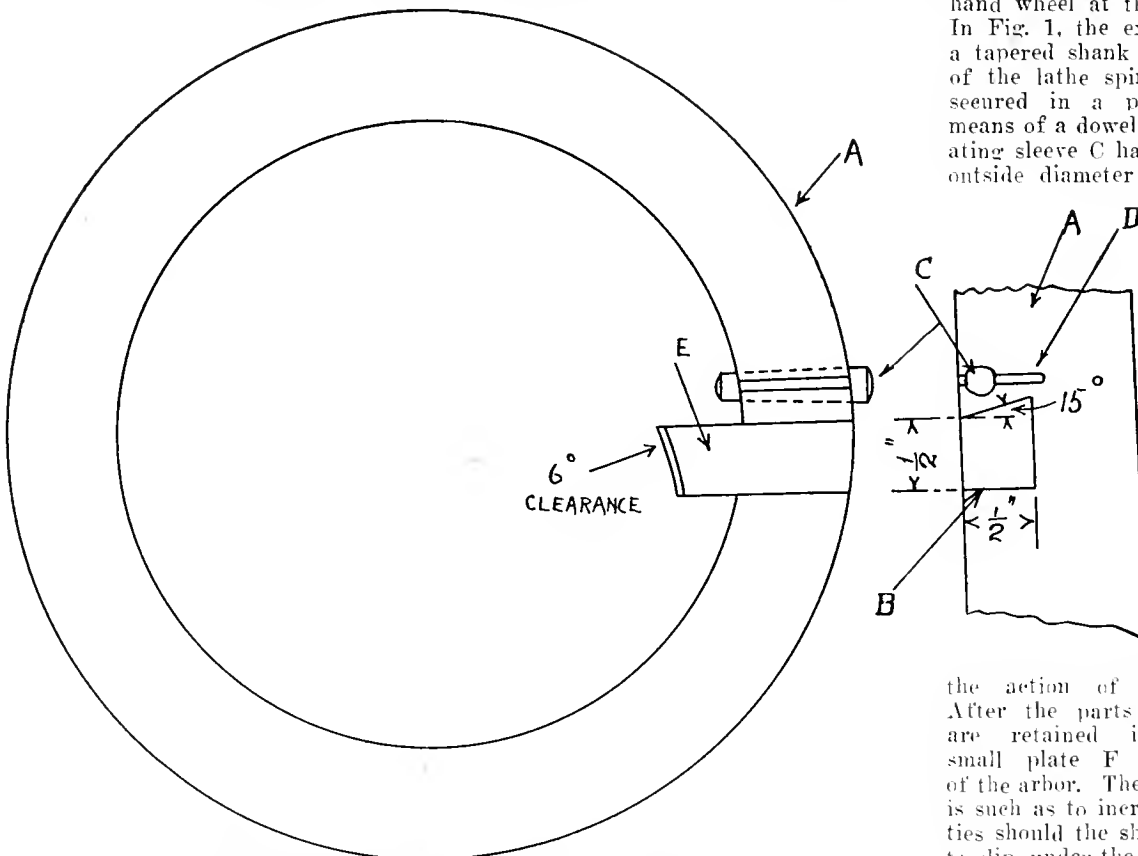

ILLUSTRATING METHOD OF MAKING THREAD-MILLING CUTTERS.

it was cut to length for the chasers. Next a master hob was made for cutting the chasers. This was made up in the form of a milling cutter, being backed off in the lathe using the regular backing-off attachment. Next a simple jig was required for holding the chasers while they were being milled as of course it is absolutely essential that

give as good results and much longer life, having high speed cutting edges, than the commercial ones.



INTERNAL CHUCKING DEVICES

By R. James.

CONCENTRICITY of wall thickness is one of the chief essentials in shell man-

in a central position by means of two plates D, one on either side. The interior of this wheel is cored out to receive the two pawls E, these are placed in opposite directions, and pivoted on the pins F, being held to position by the action of the springs G. One of the pawls is used to tighten the chuck, while the other is for releasing; these operations being accomplished either by pressure or knocking. Seamed to the nose of the lathe spindle I, is the piece J that takes the

tested for alignment so that any error can be easily detected and at once remedied.



RE-CENTERING DEVICE FOR SHELL BASES

By J. W. G.

THE device shown in the accompanying sketch has been used with complete success in re-centering adapters in large

to speed up the drill too much or irregular centres may result through the action of centrifugal force on the rollers. About 100 revs. per min. gave satisfactory results.



PLATE WELDS IN TENSION

A WELD in tension is always an indefinite quantity as regards resistance to rupture. If well made, its strength may approximate to that of the parts joined, but in most cases it is difficult to assign a definite value to the effective strength, as can be done in the case of riveted joints, and for this reason riveted joints are to be preferred wherever riveting is practicable. It is necessary that vessels with welded joints should have a higher factor of safety than those con-

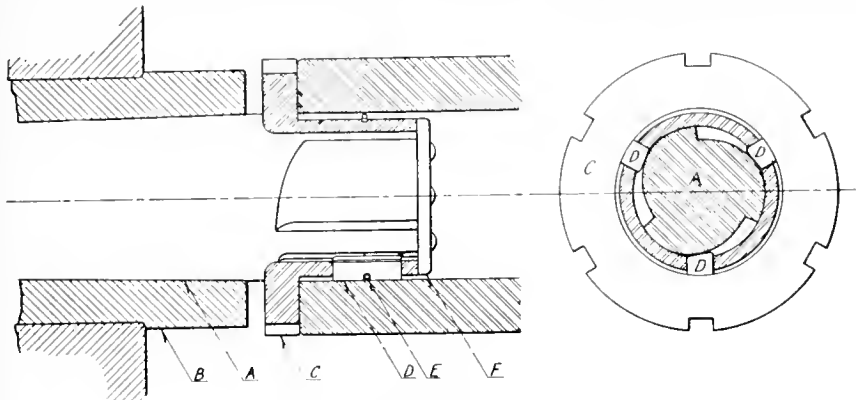
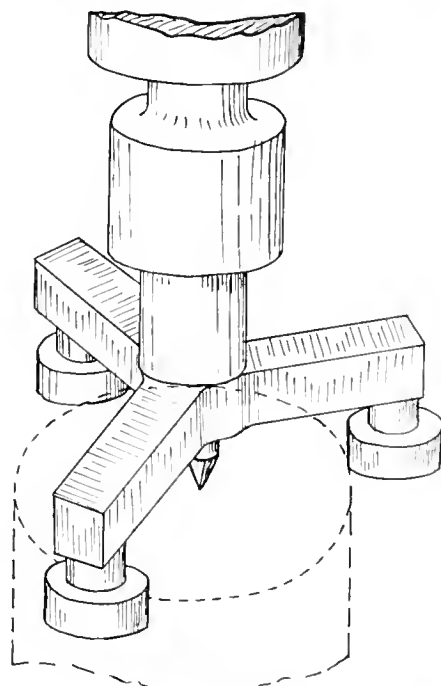

FIG. 1—EXPANDING ARBORS.

thrust of the shell and also the expanding jaws. The front end of the piece J is bored out and threaded to fit the operating bush K, which is firmly keyed to the end of the connecting rod. The outer end of the bush K has a short taper of 15 degrees which controls the expansion of the jaws M; these latter being held to position by the general practice of a ring spring. The jaws are of the sectional type and maintain a relative position to the operating bush K by means of the dowels N. The pitch of the thread on the bush is 1/4-inch, and any slight slippage of the shell under the cut, will tend to further tighten the

shells after they have been driven home tight. The centre is used for supporting the outer end during the grooving, waving and band turning operations, and must be perfectly concentric with the outer surface of the shell to insure the driving band being likewise. A sensitive drill was used for the job, the shell being held in a suitable chuck which positioned it from the outside.

Rollers are carried on a spider with two arms set 120 deg. apart, the radius being .010 to .015 in. less than the radius of a low limit shell so as to insure the centering tool being held over firmly in their direction. The tool



RE-CENTERING DEVICE FOR BASES OF 8-IN. SHELLS.

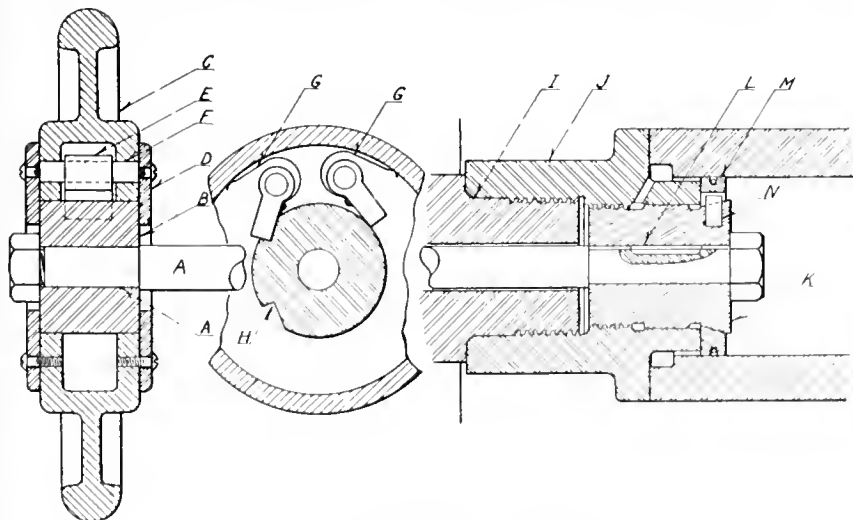

FIG. 2—EXPANDING ARBORS.

grip. In addition to the pressure that can be used to grip or release the chuck, the construction provides a handy means of jarring, by knocking the pawls E against their respective notches. To insure the accuracy of these chucks, narrow rings can be gripped in the jaws and

is also set so that its cutting edge is midway between two rollers, the reaction on the edge plus the short radius causing the tool to re-machine the surface of the original centre so that it is truly concentric with the outside surface of the shell body. Care must be taken not

structed with riveted joints, and where welding is adopted it is essential certain precautions should be followed.

In recent years, fusion welding by means of the electric arc and by the gas blow-pipe system has been largely used in constructional and repair work, while some makers of small vessels, for use in the storage of air and gas under pressure, have used one or the other of these systems of welding for the joints securing the different parts of the vessel together. Experience has shown that fusion alone cannot be trusted to unite the parts, and that hammering is indispensable to the formation of a reliable weld. In preparing the parts to be joined, their edges should be bevelled so that a V-shaped notch is formed at their junction. This should be filled by bit with the fused welding metal, and the parts hammered whilst at welding heat. If this is done there is a better chance of obtaining a sound and homogeneous weld.

PYROMETER DEVELOPMENT*

By Richard P. Brown**

AS FAR as we know the ancients who baked excellent bricks and forged iron in their crude way made use of a form of pyrometer used to-day with ever diminishing success—the eye.

The operation of the first mechanical pyrometers depended upon the difference in expansion of iron and brass. An iron tube containing a brass rod projected into a furnace, and these were mechanically connected to a multiplying movement which caused a pointer to pass around a dial. The difference in expansion of about $\frac{1}{8}$ -inch was sufficient to move the pointer up to 800 degs. Fah.

Siemens's Water Pyrometer

An instrument used quite largely 30 or 40 years ago was the Siemens water pyrometer. A copper ball weighing exactly 137 grams was placed on a piece of steel in the furnace, and after it had fully attained the temperature, it was quickly removed from the furnace and dropped into a vessel containing a thermometer and exactly one pint of clean water. The rise in temperature of the thermometer in the water could be read off in actual temperature degrees on a corresponding scale. The accuracy of this instrument necessarily depended upon exact measurement of the quantity of water in the vessel and the weight of the copper ball which scales away slowly under heat. The time taken to remove the ball from the furnace and drop it into the water must necessarily vary slightly. An accuracy within about 25 degs. Fah. was, however, usually attained with this instrument. The Siemens water pyrometer is still used by armor plate manufacturers as they can readily place a number of copper balls on a piece of armor plate which cannot be easily reached by more improved pyrometers. These instruments are in use in the armor plate department of the Bethlehem Steel Co., South Bethlehem, Pa.

Principle of Resistance Thermometers

The principle on which resistance thermometers operate is the change in resistance of metals due to change in temperature. A coil of platinum or pure nickel wire protected with a suitable tube is inserted at a point where the temperature is to be measured, and with a constant source of current passing through the coil of wire, the resistance increases or decreases, depending on the temperature. This change in resistance can be easily measured as an adjustable resistance is used to balance the resistance of the bulb, and a galvanometer shows when the balance is reached. The adjustable resistance with sliding contact arm can have a temperature scale for direct reading. This instrument is an exceedingly accurate one

for measuring low temperatures, but is hardly to be recommended for high temperature service.

Thermo-Electric Methods

For measuring temperatures above 1,000 degs. Fah., the thermo-electric method has come to be by far the most largely used. A thermo-electric pyrometer consists of a thermo-couple, a measuring device, and wires connecting the thermo-couple and the measuring device. Experience has taught us that for measuring temperatures up to 200 degs. Fah. a thermo-couple of bismuth and antimony is best. For temperature to 1,000 degs. Fah., a satisfactory thermo-couple consists of one wire of iron the other 60 per cent. nickel and 40 per cent. copper. For the measurement of temperatures as high as 1,800 degs. Fah., a very satisfactory base metal thermo-couple consists of one wire of 90 per cent. nickel and 10 per cent. chromium, the other wire 98 per cent. nickel and 2 per cent. aluminum. The General Motors Co., Detroit, has developed a base consisting of silica, manganese, nickel and aluminum.

For a long time pyrometer builders attempted to duplicate the wire in order to procure thermo-couples which would reproduce the voltage of the previous thermo-couples, but this gave large amount of trouble and no great precision could be secured. Several years ago the policy was adopted of shunting each thermo-couple with manganese wire, reducing the voltage at the terminals of the thermo-couple about two millivolts. Each thermo-couple is adjusted in an electric furnace to a standard, and a maximum error of one-tenth of a millivolt or 4 degs. is permitted. In this way a thermo-couple as sent out produces a definite voltage within 4 degs. Fah. This method of shunting the thermo-couple also permits of the customer re-standardizing his instrument at intervals.

Wire Insulation

The wires forming a thermo-couple must be insulated from each other throughout their length. This insulation must withstand high temperature, must be a good insulator, and must withstand reasonably severe handling. A common method of insulating base metal thermo-couples is to wrap them with asbestos, and paint the asbestos winding with a solution of sodium silicate. Another method is to fit lava or porcelain beads over the thermo-couple wire. For the platinum thermo-couple the insulation must be of porcelain or high grade fire clay, free from impurities.

The life which will be obtained from any thermo-couple installed in a furnace will very largely depend on the protecting tube over the thermo-couple. For temperatures up to 1,200 degs. Fah., a high grade wrought iron tube gives satisfactory results. The life of this tube can be increased by calorizing, a process which impregnates the pipe with an aluminum oxide recently developed

by the General Electric Co. This will increase the life of the pipe about three times where used at temperatures around 1,400 degs. Fah.

Compensating Box

Until a few years ago, no particular attention was given to caring for the source of error caused by changes in temperature at the cold junction of the thermo-couple. Recently, however, it has been customary to run compensating leads of the same material as the thermo-couple to a distant point, preferably under ground, where the temperature is uniform, instead of having the cold junction just outside the furnace wall, where it might vary several hundred degrees. Where it is not possible to place the cold junction in the ground, on account of the furnaces being on an upper floor of a building, a compensating box can be used. This device consists of a lamp and thermostat which will maintain the temperature constant within two degrees. These compensating boxes can be supplied to maintain the cold junction constant for any temperature from 50 to 150 degs. Fah. The temperature for which the compensating box is set must necessarily be higher than the atmospheric temperature of the room in which it is located.

Thermo-Couple Voltage Measurement

There are two distinct methods of measuring the voltage produced by a thermo-couple—the millivoltmeter method, and the potentiometer method. The millivoltmeter consists of a permanent magnet with its pole pieces, in the field of which a copper wound coil swings in jeweled bearings. Instruments of the millivoltmeter type were in extensive use commercially abroad, and to some extent here as long as 20 years ago, but the instruments were of such delicate construction as to be hardly suitable for general commercial use. Usually they were supplied with the moving coil hung between fine wire suspensions, and were easily broken through jars or handling in transit. These instruments were of high resistance, approximately 300 ohms.

On account of the delicate construction of this type of imported instrument, a standard form of switchboard millivoltmeter, frequently used as an ammeter, came into extensive use about 1905, and is still in use. It has a resistance of about 5 ohms, and each individual instrument must be calibrated for a thermo-couple of a certain length and for use with leads or wiring of a definite length. Slight changes in resistance, due to changes in the length of the thermo-couple, or length of the wiring, naturally effect the indication, as the internal resistance of this type of millivoltmeter is so low.

In the potentiometer method of temporary measurement, the electromotive force produced by the thermo-couple is measured by opposing to it a known variable electro-motive force, usually that of a dry cell contained in the

(Continued on page 322.)

*From a paper before the Steel Treating Research Club, Detroit.

**President, the Brown Instrument Co., Philadelphia.

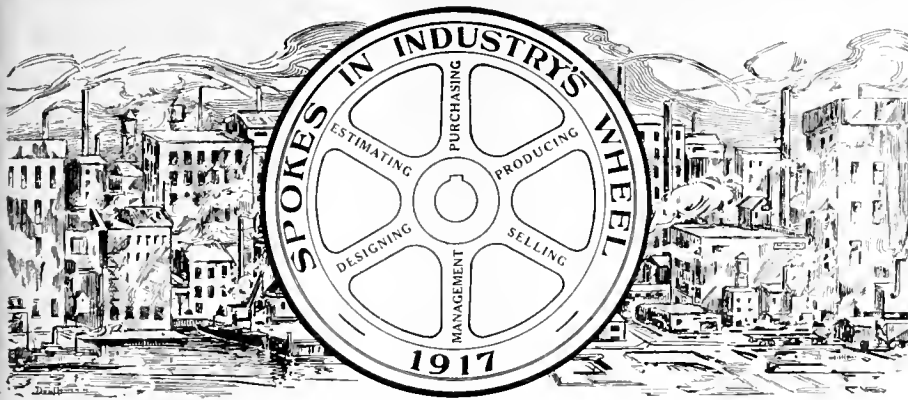

The constitution of industrial enterprise is largely departmental—"spokes in a wheel." This series of articles has for its object the featuring in a racy, interesting and instructive fashion, the training, experience and achievement of those who to-day are transmitting, effectively, energy in their capacity as "spokes in the wheels" of our metal-working establishments.

E. T. SPIDY

JUST as in the development of Canada's agricultural and mineral resources, railroading in its myriad forms of activity has been almost wholly responsible during the last four decades for the growth and present day prominence of her industrial enterprise in its variety scope. Progress in railway building and rolling stock additions and betterment has been more or less consonant with manufacturing prosperity within our borders, and even with the possibilities of a shipbuilding industry of quite gigantic proportions being permanently established on our lake, river, and ocean shores, there is little doubt, in view of the vastness of our territorial domain, otherwise unredeemable, that railroad enterprise will still continue to contribute the major quota of opportunity for our future industrial and general commercial progress. Our "Spoke" this week is from a railroad driving wheel.

E Thomas Spidy, shop engineer, Winnipeg shops, Canadian Pacific Railway Co., was born March 18, 1887, at Brighton, England, his father being a native of Glasgow, Scotland, and his mother of Brighton, England. In 1889, the family went overseas to Melbourne, Australia, leaving the latter city after a two years sojourn and settling in New Zealand. In the town of Petone, near Wellington, a start was made in the procuring of an education for our youthful traveller. With the return of the family to England in 1897, however, other plans, and under, no doubt, more auspicious opportunities, had to be made to complete the education of our "Spoke," and that he actively co-operated in these is noticeable from the fact that a year later he won a Scholarship entitling him to free tuition, etc., at York Place Science School, also at Brighton Technical College, where he took the Mechanical Engineering Course.

From the latter part of the foregoing paragraph, it will be quite apparent that Master Spidy had a mechanical

bent, hence his becoming apprenticed in 1903 at the Brighton Shops of the London, Brighton & South Coast Railway Co., will occasion little surprise. It was during this apprenticeship period that his Mechanical Engineering Course was completed, the Railway Co. co-operating toward that end by allowing all apprentices the necessary time for instruction, and otherwise encouraging them towards greater individual fitness in trade essentials.

In 1909, Mr. Spidy came to Canada.



E. T. SPIDY.

securing a position in the piecework department at the C.P.R. Angus Shops, Montreal. A perhaps fortuitous circumstance just then was the fact that H. L. Gantt, well known in matters pertaining to efficiency and system of industrial organizations, was reorganizing the piecework and schedule departments there; in any case, there is little doubt but that our "Spoke" was both an interested observer of the effects produced and a mental appropriator of the means employed and their method of application. In 1910 he was appointed to the

position of Instruction Card Inspector at the Angus Shops, and a year later earned promotion as Assistant General Foreman in charge of efficient works at the Toronto Shops of the C.P.R. During the same year—1911, he was transferred to the Company's Winnipeg Shop in the like capacity, being later promoted to the position of Shop Engineer, which is his present title.

Mr. Spidy married Miss A. M. Davies of Quebec City, in August 1913, the family consisting of one daughter 21 1/2 years of age. His private address is 4 Rubin Apartments, Fort Rouge, Winnipeg, Man. He is a junior member, American Society of Mechanical Engineers, also a local associate member of the Canadian Society of Civil Engineers, being Secretary of the Mechanical Section, Winnipeg Branch of same. He is lecturer in Mechanical Engineering, University of Manitoba, having been appointed such in 1916; the subjects taught include Machine and Steam Power Plant Design.

"My experience" says our "Spoke," has been very varied, starting with time study work in various departments, leading on to the development of tools for better production; improving layouts of machinery; scheduling and routing locomotives and cars through the different departments of a railroad shop, operating a drawing office, and maintaining the machinery of all departments etc.; a series of activities contributing to a viewpoint, that while not new, may emphasize an old one—that the value of training cannot be overestimated. First in value is the practical training and secondly the theoretical training. I fully endorse the trade educational movements evident in our large cities, but strongly urge that the practical side be given more consideration. My experience is that in the interval between the time a student leaves college or school, and the time when he needs such higher education as calculus, he usually forgets it and has to use ordinary mathematics for his problems. Apart from the training effect, this represents time lost that might be applied with advantage to the practical side of various questions."

"One of the most effective methods of increasing output, is by comparison. The latter is possible only by knowing what the "other fellow" is doing. The engineering journals fulfil this need, both in the editorial and advertising sections. I have picked out many an idea from instructive advertisements, and while often have little time except to "go through" a journal, I always do this with the eye for something new, finally removing the selected articles and filing same.

"King George got a big fight on." In the region west of the Yukon, this message, given by Indians, was the first news of the war received by H. Collier, a trapper, who promptly returned to civilization, and, in his own words, "joined up to get some good shooting."

GUIDANCE SPECIFICATION FOR TRIPLE-EXPANSION MARINE ENGINES FOR CARGO BOATS*

IN the present crisis of the country's history it is the duty of all of us to bethink ourselves and consider how we are to hold our own in the approaching contest for supremacy in the industrial world. As shipbuilders and engineers, it is specially incumbent on us to look forward to what is likely to happen after the war, and to prepare for the new conditions as far as we possibly can. Intensified and organized competition from abroad is the least that may be expected. As to whether this will be met or not depends on whether our manufacturers so bestir themselves as to procure not only vastly increased economy in production, but also increased efficiency of their products. Labor questions do not come within our present scope, and we therefore confine ourselves to the scientific and technical factors of the problem, the influence of which cannot well be over-rated. Old designs and easy-going or antiquated methods will be rigidly overhauled, and, where necessary, must be brought up to date under the guidance of the latest research and reliable experience.

Animated by these views, the Council of the Institution, after grave consideration, have taken the first step in what they trust may develop into a beneficial and helpful enterprise, and hereunder present for discussion by the members the draft of the Guidance Specification for Reciprocating Triple-expansion Engines intended for moderate-speed cargo boats engaged in general trade. The specification is based on the best practice of the day and the district, and the object in view is the ultimate standardization of parts. There is no intention whatever to change accepted and successful practice, but merely to reduce that practice to a common basis, and to add to it when desirable or necessary, in order to raise performance to the highest pitch of efficiency. It is hoped that ultimately the specification will be extended to include not only the main engine proportions and scantlings, but also the boilers, auxiliaries, and other details. Quadruple-expansion geared turbines, as well as internal combustion engines, will also be dealt with as time permits.

The Council suggest that the present instalment, as and when approved by the members in general meeting, shall be known as "The North-East Coast Institution Guidance Specification (1917) for Cargo Boat Triple-expansion Engines." It is hoped that it will be accepted by marine engine builders, and that it may prove beneficial, not only in securing maximum rate of progress in technical advance, but also in promoting convenience and despatch in the purely business sphere. The Council propose that discussion in the meantime be restricted to the subject matter of the present draft, and that an annual

revision be made in order that the specification may be kept thoroughly up to date, and may command the confidence and promote the ultimate interests of all concerned.

Specification

1—Indicated Horse Power.—For calculation purposes in this specification and in average sea conditions the I.H.P. is to be found as follows:—

$$I.H.P. = \frac{D^2 S N}{700}$$

D=diameter L.P. cylinder in inches.

S=stroke in feet.

N=revolutions per minute. Found as per Section (2).

The divisor is adjusted for a referred mean pressure of 30 lb. per square inch.

$$2\text{—Revolutions.}—N = \frac{32(S+4)}{S}$$

3—Boiler Pressure.—180 lbs. per square inch (gauge).

4—Ratios of Cylinder Areas—Ratio for 180 lb. pressure:—

H.P.	M.P.	L.P.
1	About 2.74	About 7.5
	1	2.74

5—Cuts Off at Sea Power:—
Per cent. Per cent. Per cent.
About 57.5 57.5 55

6—Speeds of Steam.—The mean steam speeds to be calculated as follows:—

$$\text{Area of cyl. in sq. in.} \times \text{piston speed in feet per sec.}$$

Area of pipe, port, or opening in sq. in. =Speed in feet per sec.

Table of mean steam speeds in feet per second:—

	H.P.	M.P.	L.P.
Main steam pipe ..	110	...	240
Port opening ...	110	150	240
Steam ports	80	85	100
Exhaust passage or pipe	60	65	75

Width of Steam Ports.—Width of ports to be about 0.8 of diameter of cylinder.

7—Maximum Load.—The maximum load on main working parts to be taken as the product of the area of H.P. cylinder in inches and the boiler pressure in pounds per sq. in. (gauge).

8.—Crank Shaft.—The diameter of crank shaft in body to be to nearest 1/8 in. above Lloyds Rule, and the proportions of the remaining parts to be not less than the following:—

(1)—Diameter of crank-pin to be equal to diameter of shaft.

(2)—Diameter of crank shaft in web to be equal to diameter of shaft plus 1/2 in.

(3)—Diameter of webs to be equal to diameter of crank pin by 1.85.

(4)—Thickness of webs to be equal to diameter of shaft by .62.

(5)—Thickness of couplings to be equal to diameter of shaft by .25.

(6)—Six coupling bolts to be used for shafts up to and including 15 in. diameter. Nine coupling bolts to be used for shafts above 15 in. diameter.

(7)—Diameter of pitch circle of coupling bolts to be 1.43 diameter of crank shaft.

(8)—Diameter of coupling bolts to be equal to:—

$$.7 \times \sqrt{\frac{\text{dia. of shaft}^3 \text{ in inches}}{\text{number of bolts} \times \text{dia. pitch circle in inches}}}$$

Bolts to be parallel.

9.—Length of Connecting-rods. — Length of connecting-rod between centres to be twice the stroke or four times the crank radius.

Diameter of Connecting-rod. — Connecting-rods may be made parallel, same diameter as piston-rod body.

Connecting-rod Top Ends.—Connecting-rods to have single top end gudgeons for all engines having H.P. cylinders of 25 in. diameter and under.

10.—Crosshead Guides.—Main cross-head guides to be of the single type in all sizes of engine.

Load on Main Crosshead Guides. — Maximum load in pounds on crosshead guides to be taken as:—

$$\text{Area of H.P. cyl. in sq. in.} \times \text{boiler pressure in pounds per sq. in (gauge)}$$

4

11.—Maximum Pressures on Principal Bearing Surfaces:—

	Lbs. per sq. in.
Main bearings	250
Crank pins	500
Crosshead gudgeons	1000
Guide shoes (ahead)	55
Guide shoes (astern)	110

Diameter by length to be taken as area of bearings.

Overall length by overall breadth as area of guide shoes.

12.—Maximum Stresses on Principal Working Parts:—

	Lbs. per sq. in.
Ingot steel piston rod at screw	6000
Piston-rod body (after deducting 1/4 in. from diameter to allow for returning)	3000
Piston and connecting-rod bolts at screw	5500
Main bearing bolts	4500
Main bearing keeps (if forged)	6000
Connecting-rod bottom end keep (if forged)	7500
Piston-rod keep (if forged)	7500

(The keeps are calculated as beams with distributed load and supported ends.)

13.—Valve Gear. — The valve gear sizes to be determined from the load on the M.P. slide valve spindle, calculated as follows:—

$$\text{Load in pounds} = .165 [54 (A-B) - 9 C]$$

Where A = area of face of M.P. valve
B = combined area of steam ports in valve face in sq. in.

C = combined area of exhaust ports in valve face in sq. in.

Valve Spindles.—Diameter of valve spindles at gland to be not less than:—
Diameter of piston-rod at gland

$$+ \frac{5}{8} \text{ in.}$$

*Compiled by the Council and Members of the North-East Coast Institution of Engineers and Shipbuilders, 1917.

Maximum Pressures on Bearing Surfaces of Valve Gears:—

	Lbs. per sq. in.
Link block gudgeon	500.
Link block slippers	300
Eccentric rod top end pins.	500
Eccentric sheaves (ahead and astern)	85

14.—Thrust Block.—When of horse-shoe type, the pressure on thrust collars not to exceed 70 lb. per square inch when calculated from indicated thrust, which is determined as follows:—

Lbs. Indicated thrust =
I.H.P. × 33,000

Pitch in feet × revs. per min.

15.—Circulating Water.—The amount of circulating water supplied to be 40 times the feed, taking the latter at 15 lb. of steam per I.H.P. per hour.

16.—Main Engine-driven Reciprocating Circulating Pump (Double-acting).—To be proportioned to deliver the above quantity of water at a displacement efficiency of 80 per cent.

17.—Maximum Speeds of Circulating Water.—The speeds of circulating water are to be calculated as follows:—

.8 area of bucket in sq. in × bucket speed in feet per sec.

Area of passage in square inches = Speed of water.

Approximate Speeds in Feet per Second

	Feet per second.
Main injection	9.0
Passages in pump	5.0
Valve grids	6.0
Past lift of valves	9.5
Discharge pipe	7.5

18.—Air Pump.—Capacity of air pump not less than one-sixteenth of the capacity of L. P. cylinder.

19.—Main Engine-driven Feed Pumps. Capacity each engine-driven feed pump 1-700th of capacity of L. P. cylinder.

20.—Pump Gear.—Load on pump gear to be calculated as follows:—Load in pounds = 25 (area of air pump bucket + area of circulating pump bucket) + 15 (area of both feed pump rams + area of both bilge pump rams). All in sq. in.

Maximum Pressures on Pump Gear

	Pounds per sq. in.
Pump link pins	400
Engine link pins	300
Pump lever centre gudgeon bearings	250

For cargo vessels of large tonnage it is recommended that the circulating and feed pumps be independently driven pumps.

21.—Utilisation of Heat in Exhaust Steam from Auxiliary Engines.—A source of very considerable economy in a marine installation being the complete absorption by the feed water of the heat in the exhaust steam from the various auxiliaries including the steering engine electric light engine, and evaporator, such a vacuum should be carried in the main condenser as will enable this to be effected in all seas in which the vessel trades. A vacuum of 27in., maintained in the steam space of the condenser, the temperature of the sea being 70 deg. Fah. (barometer 30in.), has been found to meet these requirements on an average cargo boat.

22.—Cooling Surface.—In determining the amount of cooling surface per I. H. P. average at sea, provision should be made for the rapid initial degrading effect of oil and scale on the tube surfaces, and also for the permanent prejudicial effect on the condensing efficiency of the residual air in the condenser

23.—Air Extraction by Steam Jet.—When a steam jet is employed for the extraction of air, and a suitable design of condenser is adopted, the greatly increased efficiency of the condensing surface enables a higher temperature of feed to be obtained, and for a given vacuum the sizes of air pump and circulating pump, to be considerably reduced, thereby saving pumping power and total weight.

24.—Pressure Losses in Vacuum System.—It is important to minimise the loss in absolute pressure between the steam space in the condenser and the mean vacuum line as shown on the L. P. indicator diagram, and also the loss between the steam space in the condenser and the air pump suction pipe.

In good practice (a) the vacuum line should scale 12½lb., per sq. in. below the atmospheric line when the vacuum in the steam space of the condenser is 27in., (b) the speed of steam over the condensing surface should be such that the total resistance through the condenser does not exceed one-tenth of an inch of mercury or 1.36 in. of water, as measured by a resistance gauge.

25.—Prevention of Delivery of Oil to Boilers.—It is desirable that the oil should be separated from the auxiliary exhaust steam before it is used to heat the feed-water, but in any case the feed water must be passed through a satisfactory filter before delivery to boilers.

26.—De-aeration of Feed-water.—Means should be provided for the de-aeration of feed-water before it enters the boiler, with the object of preventing corrosion.

27.—Prevention of Heat Loss by Lagging.—Heat loss by radiation from unprotected surfaces being a very appreciable factor in the ultimate economy of a steam installation, the lagging of boilers, steam pipes, cylinders, auxiliary exhaust pipes, and feed pipes should receive expert attention in order to promote efficiency by means of an adequate thickness of non-conducting material applied in a workmanlike manner.

Taxation of minerals is discussed at length, but a hasty examination of the volume does not reveal any concrete recommendation as to what the Ontario tax should be. The evidence taken before the commission is given in an appendix. Through the report runs a seam of warning as to the dangers of confiscation, and of the evils that may arise should capital be intimidated.

The only reference to Ontario nickel reaching the Germans is contained in a short paragraph which deals with conferences held with the Imperial Government. The only comment is that for obvious reasons these conferences were secret, and what transpired could not be divulged.



ONTARIO GOVERNMENT ESTIMATES

FURTHER supplementary estimates totalling \$1,468,000 were tabled in the Legislature on Monday. Of this amount \$218,706 represents grants for colonization road construction in Northern Ontario and a further \$161,731 expenditures to be made on general public works, roads, bridges, etc., in the North.

Accompanying the supplementary estimates is an estimate of capital expenditure proposed for the T. and N. O. and the Hydro-Electric Commission. The commission plans to spend \$6,928,790. Of this \$1,000,000 is for work upon the Niagara power development, \$2,360,000 on Niagara transformer stations, \$985,000 on Niagara system steel tower lines and \$1,695,000 for Niagara system extensions. There are also substantial estimates for extensions of the Severn, St. Lawrence, Engenia and Muskoka systems.

The T. and N.O. plans to spend \$876,000, of which \$250,000 is for 100 new freight cars to replace those burned, \$100,000 for the erection of steel bridges in place of timber bridges \$125,000 for the extension of the Kirkland Lake branch and \$143,000 for general construction work. The T. and N.O. and Hydro estimates bring the total presented yesterday to \$7,805,383.



Cooling Electrical Machinery.—In the cooling of electrical machinery, with the high speed units of large output, the designer is seriously handicapped, says the *Electrician*. As turbo-alternators go in these days, the 15,000 kilovolt-ampere alternator is a machine of medium size. In such a machine the total loss is about 545 kilowatts, and an enormous volume of cooling air is required for carrying away the heat due to this loss. According to B. G. Lamme, a simple approximate rule for determining the quantity of cooling air required is that an expenditure of one kilowatt in one minute will raise the temperature of 100 cubic feet of air 18 deg. cent. Therefore, for a temperature rise of the outgoing air of 20 deg. Cent. above that of the incoming air, a loss of 545 kilowatts will necessitate a supply of ventilating air of approximately 50,000 cubic feet per minute.



ONTARIO NICKEL DEPOSITS

THE report of the Province of Ontario Royal Commission on nickel was brought down in the House on March 26. It is a complete history of the nickel industry done up in a neat volume of 600 pages. Its cost is estimated at \$60,000. It tells of the difficulties to be overcome before the metal could be refined in Canada, and of the triumph of science over sulphur fumes. The amount of nickel in sight in Ontario is given as about 70 million tons, but it is estimated that the total deposits amount to about double the amount.

POWER AND ITS GENERATION

Power, However Generated, and Ultimately Transmitted, is a Prime Essential of Manufacturing Enterprise. The Discussion of its Cost Side is this Departmental Objective

STEAM POWER ECONOMICS*

By C. E. Stromeyer.

THE present war, with its accompanying high prices and the possibility of a trade war after the conclusion of peace, has naturally directed attention to many economic questions, including those relating to steam boilers.

Discussions about the difference between English and German economic systems of operating factories have revealed that abroad great harmony exists between the State and manufacturers, and, as a consequence, German works have adopted systems which commend themselves because of their leading to national economy. Our customs seem to force individual works to think more of themselves than of the country's welfare. Here we need only concern ourselves with the fuel question which is briefly as follows: Our manufacturers have been spoiled by the ease with which they could obtain the very best coal in the world. When new labor-saving appliances were invented which, while increasing the output, also increased the power required to drive them, the manufacturers filled their works with them and overworked their boilers; and as this could only be done with the best of coal, slack was for long periods a drug in the market.

Wasted Coal Percentage

Constant improvements in mechanical stokers have effected a change, but no overworked boiler can burn dirty coal, no matter whether it be fed by hand or by mechanical means, and slowly but surely colliery owners found that it did not pay to bring inferior qualities of coal to the surface. As most coal seams consist of several layers, of which some are rich and others poor, the poorer layers of worked seams are often left underground and buried for ever, because to mix them with the richer ones would disproportionately lower their value.

According to recent statements by coal experts, this wasted coal amounts to 25 per cent. of the output. This national waste is due largely to our almost universal practice of overworking boilers. Bunker coal for steamers must, of course, be as free as possible from mineral matter, and export coal has also to be reasonably pure, but there is no reason, except want of boiler power in our factories, why inferior coal should not be burnt wherever it can be got. It is done on the Continent of Europe, because first-class coal cannot be obtained, but there the works provide themselves with ample boiler power, and on the whole they obtain a higher efficiency

*From annual report of Manchester Steam Users Association; of which Mr. Stromeyer is Chief Engineer.

than we can hope for with our superior coal but hard-worked boilers.

Coke as Fuel

Somewhat similar remarks might be made about the burning of coke. It is a by-product of the gas works of towns, and might with gas be a valuable by-product of works which would make it their business to produce sulphate of ammonia and the volatile oils of distillation. Coke ought, therefore, to be a cheap fuel. At present, however, its production is limited, and those consumers who are compelled to use it as a fuel can be made to pay so heavy a price for it, that the profits can be used for relieving the rates. Steam users naturally do not like coke, partly on account of its relatively high price and partly because it would require larger boilers than the present ones in which to burn it with as good effect as the best coal. Thus, here again, our habit of getting the highest possible duty out of our boilers may be looked upon as being one of the causes, though perhaps only a secondary one, which hamper our coal-tar industry.

Our present practice may possibly be more profitable to the individual factories and collieries than to those of the Continent of Europe, though this is a moot point, but there can be no doubt that this practice is very wasteful of our national coal resources, and it is to be hoped that after the war encouragement will be held out to those who, without loss to themselves, will assist at national economy.

Take the simple case of a shipowner who has to decide for what speed a ship, which he contemplates ordering, should be designed. He knows that with a low speed his ship cannot command paying freights, and, going to the other extreme, he also knows that if he fills his ship with engines and boilers, there will be no room for cargo, and his coal bill will be far in excess of his earnings. He will, therefore, have to decide on a medium speed which here may be assumed to be 10 or 11 knots. With the faster ship he will be able to make 10 per cent. more voyages than with the slower one, but his annual coal bill will be increased 20 per cent. and his carrying capacity slightly decreased, on account of the extra 20 per cent. of engine, boiler, and bunker capacity. Leaning on past experiences he may be able to say to himself that his prospective earnings would be about the same, no matter whether he were to decide on the 10 or the 11-knot boat. At this point national economic considerations ought to influence him, and he ought to say to himself: The 11-knot boat will carry 10 per cent. more cargo than the 10-knot boat, but it will burn 20 per cent. more coal. My profit

will be the same with either speed; therefore, in order to assist my country in saving coal, I will decide to have the slower boat.

The factory owner is faced with other, but similar, problems, and will find that he too can make selections amongst a number of alternatives of which he should choose the one which, while it does not affect his profits, will be of economic advantage to the nation. It will be my endeavor to review these several alternatives.

Fuel Cost Contributories

The cost of fuel depends, of course, on the cost of labor, and that depends on the average cost of living. This will necessarily be increased after the war on account of the heavy taxation to which we as a nation will be subjected; but it is impossible to make even the vaguest guess as to the extent to which future prices of fuel will be affected by the increase in cost of fuel which may occur. We may assume that the coal consumption for a first-class modern steam engine can be reduced nearly down to one pound of coal per indicated horse power, or nearly 4 tons per year continuous working. In most factories only about one-third of the full time is worked, whereas the interest on capital is a continuous charge, and the total cost, including wear and tear, was in one modern factory found to be \$60 per indicated horse power per annum, at a time when the cost of fuel was \$3 per ton. Had the factory been working night and day the cost would have been \$30 per indicated horse power per annum.

This compares very unfavorably with \$8.50 to \$12.15 per electric horse power, which is approximately the cost of continuous power production in some parts of Sweden, Norway, and on the slopes of the Alps. These districts are rapidly realizing that they can control enormous powers, and when these have been harnessed they are sure to attract to themselves many of our industries. After the war, wages now ruling are likely to be at least maintained, and the disproportion is likely to be increased. Then also, as the United States is not going to burden herself with additional taxes, the cost of living will not be increased there. The most threatening possibility, however, is that Prussia, true to her national traditions, not to be saddled with a national debt (her present one of 600 millions being merely an industrial one created when the State acquired all the railways), may repudiate all her internal war loans, and after a few years of severe personal hardship the taxation in Prussia, and consequently the average cost of living, and with it the price of labor and of coal, will be as low as before the war.

Record of Engine Performances

We may, therefore, expect that some time after the war, our cost of creating power for industrial purposes will be greater than in other countries, so that even without considering the question of economizing our national coal resources, it will be necessary for individual works to practise extreme economy as regards coal consumption.

In order to be able to reach a reliable starting point as to possible fuel economies, I have prepared the following list

been classified according to the type of engines used, viz., low and high pressure compound, compound using superheated steam, and to triple expansion engines. The original returns embody the amounts of coal used for non-power purposes. In those mills where a separate boiler, usually a low-pressure one, was used for burning this coal, the return may have been fairly correct, but other returns are mere guesswork. However, by combining the most reliable of the available cases, the average fuel consumed in spin-

is about 2.15 lbs. of coal per indicated horse power, and for triple-expansion high-pressure engines it is about 1.65 lbs. of coal per indicated horse power. The few compound engines which use superheated steam do not show up as well as might have been expected, but with one exception these engines are of an old type.

These results are neither as good as the results promised by engine builders nor as those attained during trials. This is but natural and should not be allowed

Works No.	Date.	Steam Pressure, Lbs.	Mean Indicated Horse-power.	Mean Coal Consumption per I.H.P.			Remarks.
				Gross. Lbs.	Heat-ing, etc. Lbs.	Nett. Lbs.	
<i>Cotton Spinning Mills. Compound Engines.</i>							
1	—	85	770	2.90	0.87	2.03	
2	—	85	500, 520 350, 300	3.56	—	—	Up to 1913.
2	—	85	do.	3.23	—	—	After 1908, but later consumption in-creased to 4.09lbs. Up to 1904.
3	—	100	50 single 270, 260	3.58	—	—	After 1904.
3	—	100	50 single 290, 270	3.67	—	—	One trial 1909.
3	—	100	50 single 280, 270	3.76	0.89	2.87	
4	—	100	620	3.13	0.32	2.81	Up to 1914.
4	—	100	390	4.57	0.76	3.81	Reduced power after 1914.
5	1864	100	400, 400	4.09	—	—	Burning slack.
6	1879	100	590, 230	2.71	0.89	1.82	
7	—	100	350, 350 450	3.85	0.71	3.14	
8	1885	105	1000	2.34	0.28	2.06	
9	—	107	450	3.80	0.60	3.20	Only two years' tests
10	1900	120	640	2.60	0.13	2.47	Only one test.
11	1833	130	1200	2.72	—	—	
12	1909	138	700	2.81	—	—	Only two years' tests
13	1910	145	690	2.85	0.66	2.19	
13	1899	145	980, 550	2.67	0.60	2.07	690 is a triple expansion engine.
14	1877 1875	160	380 980	2.69	0.40	2.29	
15	1910	160	700	2.78	0.62	2.16	Only one test.
16	—	160	1400	2.32	—	—	Friction of engine, main and counter-shafting 24.6 %
17	1910	180	1200	2.65	0.34	2.31	
18	1913	180	1220	2.18	0.32	1.86	Only two years' tests
<i>Cotton Spinning Mills. Compound Engines. Superheated Steam.</i>							
19	—	85	400, 400	3.14	1.10	2.04	Only two years' tests
20	1885	100	100 single 1300	2.56	0.83	1.73	Only two years' tests
21	1873	140	580	2.71	0.67	2.04	
22	1910	160	1300	2.20	0.45	1.75	

TABLE I. DATA FROM MISCELLANEOUS INDUSTRIAL PLANTS OF 300 I.H.P. AND OVER.

Works No.	Date.	Steam Pressure, Lbs.	Mean Indicated Horse-power.	Mean Coal Consumption per I.H.P.			Remarks.
				Gross. Lbs.	Heat-ing, etc. Lbs.	Nett. Lbs.	
<i>Cotton Spinning Mills. Triple Expansion Engines.</i>							
23	1907	168	1480	2.02	0.38	1.64	Only one test.
24	1905	180	1400	2.33	—	—	
<i>Weaving Mills. Compound Engines.</i>							
25	—	80	320, 320	2.97	0.61	2.37	Up to 1903.
25	—	80	350, 340	2.77	0.60	2.17	Engine speeded up in 1903.
26	—	85	330	3.46	0.25	3.21	Up to 1908.
26	—	85	340	3.53	—	—	After 1908.
26	—	85	260	4.18	—	—	Do. Low power.
27	—	105	500, 280	3.43	—	—	
27	1915	160	560, 290	3.20	—	—	A new engine, one test
28	1898	120	340	3.96	1.81	2.15	
29	—	120	400	3.23	1.07	2.16	
29	—	120	346	3.80	1.37	2.53	Reduced power.
30	1909	160	450	2.30	—	—	Only two years' tests.
31	1907	165	1200, 900	2.33	0.31	2.02	Only one test.
<i>Worsted Spinning. Compound Engines.</i>							
32	—	90	510	4.58	0.42	4.16	Up to 1912. Over-worked 1912. Reduced h.p. cylinders and added an auxiliary engine.
32	—	90	400, 160	3.92	0.31	3.58	
<i>Silk Works. Compound Engines.</i>							
33	—	73	280	4.25	1.45	2.80	
<i>Paper Works. Compound Engines.</i>							
34	—	133	750	4.25	—	—	Only one test.
<i>Flour Mills. Compound Engines.</i>							
35	—	120	350	2.88	—	—	
36	1880	80	360	2.94	—	—	Only one test.
36	1911	160	350	2.00	—	—	Fuel saving stated to be 20 tons per week of 136 hours.
<i>Wire Works. Compound Engines.</i>							
37	—	120	430, 420	2.24	—	—	Only one test.

TABLE II. DATA FROM MISCELLANEOUS INDUSTRIAL PLANTS OF 300 I.H.P. AND OVER.

of engine performances. This is merely a repetition of the work which was done quarterly during the infancy of the Manchester Steam Users' Association, for at that time it was the custom to collect and publish information about the engine performances of our members. There seems to have been a greater willingness in those days than now to let us have the desired details, for although our membership has enormously increased since then, the present list is much smaller and less comprehensive than our earlier ones.

The majority of the recorded results are from spinning mills, and these have

been classified according to the type of engines used, viz., low and high pressure compound, compound using superheated steam, and to triple expansion engines. The original returns embody the amounts of coal used for non-power purposes. In those mills where a separate boiler, usually a low-pressure one, was used for burning this coal, the return may have been fairly correct, but other returns are mere guesswork. However, by combining the most reliable of the available cases, the average fuel consumed in spin-

Spinning Mill Power

The deductions which can be drawn from that part of the table which deals with the cotton spinning mills are, roughly speaking, that compound engines using steam of 100 lbs. pressure consume about 3.0 lbs. of coal per indicated horse power. For high-pressure compound engines, the net consumption

to influence intending purchasers, for it must be remembered that a factory engine stands idle for two-thirds of its time, and that the raising of steam and the banking up of fires costs much fuel, say, 0.3 lb. per indicated horse power. If we make this further deduction we arrive at the following average net consumptions per indicated horse powers under ordinary working conditions, which are, of course, never as favorable as trial conditions, at which the makers attend and try to minimize all losses.

Old compound engines working with about 100 lbs. pressure consume about 2.70 lbs.

High-pressure compound engines consume about 1.85 lbs.

High-pressure compound engines with superheated steam consume about 1.45 lbs.

Tripe-expansion engines consume about 1.33 lbs.

Several cases in the table show how disadvantageous it is to use engines which are either too small or too large for the power produced by them, and one case demonstrates the advantage of speeding up an engine, but this remedy has its limits. No. 16 was tested with only the main and countershafting running, and showed that only about 75 per cent. of the indicated horse power reaches the spindles.

Weaving Mill Power

The information gathered from weaving mills is very unsatisfactory, for the average returns for heating and slashing, which ought to be very much more than spinning, are only about 0.8-lb. per indicated horse power; or if we deduct 3.0 lbs. net, as found for low-pressure compound engines of spinning mills, from the gross power of similar engines in weaving sheds, the coal used for heating and slashing seems to be only 0.4 lb., which is 0.2 lb. less than for heating alone. This discrepancy may be due in part to the fact that weaving sheds are flat structures and, therefore, not cooled as much by cold winds as are the high-built cotton mills. Possibly, too, the relatively heavy coal bills for power, heating, and slashing, tend towards rigid economy in the engine and boiler departments. On account of these uncertainties the following single case of a spinning and weaving mill may prove of interest, for here the heating was done by separate boilers.

Very careful records have been kept for a full year and the results work out at 1.36 lbs. of coal per indicated horse power, for power alone, and 1.23 lbs. for heating, slashing, and washing; deducting 0.6 lb. for heating, the slashing and washing process in this mill costs 0.63 lb. These works make fancy cloths—these include thick materials, for which the spinning and weaving powers are less than the average cloths, and for which the water to be evaporated in the slashing process is a maximum.

The above works produced their own electricity by means of a turbine. In some parts of the mill each loom has its own motor, in other parts a large motor is attached to the countershafts. Here the losses will be about 8 per cent. for the motor, and 15 per cent. for the countershafts, and then there will be about 10 per cent. loss between the turbine and the switchboard. The efficiency of this part of the works will, therefore, be $90 \times 0.85 \times 0.92 = 66.5$ per cent. The small driven motors on the looms will have an efficiency of about 10 per cent., so that the efficiency will be about $90 \times 0.9 = 81$ per cent. The mean efficiency for the whole mill will, therefore, be about 74 per cent. This is practically the same efficiency as determined for mill No. 16 in the table. Electricity mea-

sured at the switchboard is practically the same as brake horse power and, therefore, an electric unit is equal to about 1.5 indicated horse power.

Flour Mill Power

The tabulated results for flour mills are too few for the obtaining of average results, but the saving effected in the case of mill No. 36 is very gratifying. The data are of importance to those whose engines are of an old type, and, therefore, likely to be inefficient, because it will give some indication as to whether advantages are likely to be gained by renewing the installations on modern lines. Of course, each case must be judged on its merits.

Now it is evident from the above table that, as a rule, only about 1 lb. or 2 lbs. of coal per indicated horse power, or, say, \$5 to \$15 per annum, is likely to be saved by modernizing an old power plant. If, in addition, arrangements were to be made, by providing ample boiler power, for burning a cheaper quality of coal, a very great monetary saving might be effected, but unless collieries will provide inferior fuel to individual works, this desirable policy can only be carried out by large combinations of power producers.

Production and Transmission of Power

The Newcastle Electric Supply Co. has in a way shown what can be done in this direction, and their work has also revealed the difficulties which would have to be overcome in other districts than their own before success can be obtained. Their leading idea seems to have been to provide trunk wires which would do for power what railways do for goods. They provide collieries and ironworks with outlets for any power which may be produced from their waste coal and from the waste heat of their furnaces, and they thus provide the means for the sale of this power which would otherwise be wasted. This company has in some respects been favored by local conditions, but it had also to contend with serious difficulties which are even more serious in other districts. It had the advantage of promises from all the large works on the Tyne to buy power from them, and its first power stations could, therefore, be designed to work with large units and with a minimum of cost. Subsequently the North-Eastern Railway Co. agreed to purchase all its power for local traffic.

On the other hand, the Board of Trade limit on the voltage in the trunk wires made these connecting links very expensive, and as nearly every old power station had its own voltage and its own frequency of phase, practically every amalgamation necessitated the erection of entirely new installations. An initial difficulty, which has however been nearly overcome, was that the numerous corporations had the right to exclude outsiders from supplying their little districts with power; but they have seen the advantage of adapting their voltages and frequencies of phase to those of the company, and now they buy their electric power from it for the purpose of distributing it amongst their customers.

As far as can be ascertained, the charge per unit of electricity, if used all the year round without a break, has been reduced to about \$22.50 per electric horse power. For eight-hourly supply, the charge would, of course, be much heavier, possibly as heavy as the cost of individual power production by a modern steam engine.

One reason why power can be produced thus cheaply is that the company with its network of transmitting wires can deal with collieries on the following lines: Each colliery can bring, or bring to bank some very dirty coal or shale, which is absolutely unsaleable. Of this fuel about 25 per cent. can be burnt in the colliery boilers, but the remainder is thrown on waste heaps and is occasionally burnt there. Now, the company, by installing a power station with ample boiler power close to the collieries, could consume all this apparently valueless fuel and produce four times as much power as was needed by the colliery. The colliery buys its quarter share and the rest is carried away in the trunk wires.

Ironworks are utilized in the same way. The heat wasted by the gases which escape from blast and other furnaces is far in excess of the power requirements, and was largely wasted, because without a trunk system to carry away the surplus power it could not be used. Now all this waste power is bought at a cheap rate and distributed.

In other industrial districts the conditions for conveying and selling power are rather unfavorable. The numerous corporations still exclude outside producers from within their boundaries, nor will they buy from outsiders, and they have not the necessary powers for building power stations outside their own districts, and thus utilizing the waste fuel of collieries. To produce cheap power from fuel, which has had to be carted to their own works, is out of the question. They also have not the necessary powers for supplying outsiders, and are, therefore, in the most unfavorable position for acting as power brokers or intermediaries for the buying and selling of power. What makes matters worse is that nearly every corporation has its own particular voltage and phase, so that it could not, even if it would, buy and sell power from and to others.

This condition of things is not likely to change until factory owners learn that, with a proper system, they could easily be supplied with power at a cheaper rate than that at which they can produce it.

Gas From Coal

Another means of distributing power and economizing our coal resources is to convert coal into gas, distribute it in pipes and sell the by-products, thus encouraging agriculture and the coal tar industry. In a certain sense our corporations work on these lines, and even produce a third by-product—coke. The production and sale of coke might be encouraged more than it is, because it is a smokeless fuel; but here again we find the same conflicts as in the electrical field: corporation gas is too costly for

cheap heating and power production, and producers of power gas are practically prohibited from introducing their pipes into towns.

It might be possible to combine the gas and electricity systems, then gas and its by-products could be produced from waste coal, and this gas could be used in internal combustion engines, to produce electricity. Unfortunately, however, the gas engine is not as reliable as might be wished, and it is also disliked because of the irregularities of its revolutions which cause flickering of lights and troubles in spinning mills. We have, therefore, to wait, but possibly not for long, for the perfection of the internal combustion turbine. At present the steam turbine seems to combine the greatest number of advantages; not only is its running very steady, but new designs are reported to be very economical.

The fuel economy question may, therefore, be briefly summarized by saying that hardly any improvement is likely to be effected in the economic working of boilers, for, as is well known, there is only a margin of about 20 to 25 per cent. to play with. Considerable pecuniary saving might often be effected by increasing the number of boilers, so as to be able to burn a poor and relatively cheap fuel if this can be got. For instance if, when best coal costs \$5, dirty coal of, say, 75 per cent. heating value were obtainable for, say, \$1.50 per ton, the coal bill would be reduced to one-half, but only if the local colliery can bring this dirty coal to bank and if the boilers are large enough to burn it.

Prime Mover Development

Our chief hopes will, therefore, have to be centred on engine improvements, for here large savings might be possible, because at present about eight units are thrown away for every one doing useful work. Improvements have been and still are being effected by inventors, and research workers have little scope for their activity. Research workers have already indicated very clearly that the internal combustion engine can attain a much higher efficiency than the steam engine, but the high cost of the fuel, either oil or gas, nearly balances this advantage, and constant engine troubles and repairs are both annoying and costly. Research workers have also shown that the turbine should be much more efficient than the reciprocating engine, but it is only comparatively recently that the efficiency of the steam turbine has equalled and slightly surpassed that of its older rival, and we look to inventors, rather than researchers, to reduce the remaining losses to a minimum, for the most convenient form of extracting power from coal is still the old method of burning it under a boiler. Central power stations are not limited in their choice to the steam engine for power production, and in view of the very high theoretical efficiency of internal combustion engines they very likely hope to see the internal combustion turbine brought to perfection.

From a national economic point of view, the combination of the internal

combustion engine with electric distribution of power would seem an ideal one. Our collieries would then be encouraged to mine even our dirtiest coal. This coal would produce by-products for farmers and for the coal tar industries, and supply the engines with suitable gas, and our factories would receive their power at a lower cost than they could produce it.



BRITISH SPECIFICATIONS IN FOREIGN LANGUAGES

THE British Standards Committee, with a view to assisting the maintenance and extension of British trade after the war, has determined to translate its specifications into French, Spanish and Russian, to give metric equivalents of English measures and to issue the specifications at a much lower price than has hitherto been possible. This fact was incorporated at the annual report of the Council of the Institution of Mechanical Engineers, which held its seventieth annual general meeting in London, Feb. 16. Arrangements are being made to establish local committees in the colonies and in foreign countries to obtain information and facilitate commercial transactions. The institution has appropriated a sum of \$2,500 as a donation to the fund for this purpose. Michael Longridge was elected president to succeed Dr. W. C. Unwin, who has been president for the last two years. Dugald Clerk, Sir Robert Hadfield and Mark Robinson were elected vice-presidents.



CANADIAN NICKEL EXPORTS

FIGURES showing that Canada's exports of nickel in the fiscal year ended March 31, 1916, amounted to 70,443,000 pounds, valued at \$7,714,769, are contained in the report of the Department of Trade and Commerce, Ottawa just issued. Of this total 41,610,000 pounds, valued at \$1,779,801, went to Great Britain, and 58,832,000 pounds, valued at \$5,943,969, went to the United States.

From the figures it would appear that in the fiscal years ended March 31, 1912, and March 31, 1913, no Canadian nickel was exported to Germany. In the fiscal year which ended on March 31, 1914, that is to say, a year before the war began Germany received 108,138 pounds of Canadian nickel ore or matte. In the following year, ended March 31, 1915, again Germany received 179,354 pounds, valued at \$22,866. Then the measures taken to prevent Canadian nickel reaching Germany took effect and from that date onward not a pound was exported to that country.



Training the Juniors.—The New South Wales Minister of Education has stated that his department should supervise and ensure the compulsory apprenticing of youths to some regular trade or calling before they are severed completely from their school life, in order to prevent the drifting of thousands of lads into unskilled occupations.

DEVELOPMENT OF STEEL CASTINGS MANUFACTURE

AT a recent meeting of the Manchester Association of Engineers, the first part of a paper—on the "Development of the Manufacture of Steel Castings," was read by Ernest F. Lange, M.I. Mech.E., A.M. Inst. C.E. A two-section sub-division was made, namely—1, Crucible steel processes, and 2, Bessemer steel processes. In the first, the author traced the history of the crucible processes of manufacture from Reaumur's early writings and experiments up to the present, dealing incidentally with Huntsman's discovery of cast steel, the Siemens regenerative crucible steel furnace, "Mitis" steel castings, the modern coke-fired furnace, and Krupp's steel foundry. In the second section the author traced the development of the Bessemer steel processes. The Walrand and Robert converters were described, and the author compared the features of the former with the Tropenas converter, which to-day is the most extensively used.

Referring to the Walrand-Légenis process, it was stated that the most important claim on its behalf was that it enabled the production of hot fluid metal to be achieved on a smaller scale than any known method, other than by crucibles. It was mentioned in this respect that there is in use in Paris a 1½-ton converter giving a perfectly hot fluid steel with the Walrand method of ferro-silicon superheating. The author concluded this section of the paper with a description of the Stock oil-fired converter. He said that in no country had the small converter process for the manufacture of steel castings had a greater development than in Belgium, although at first glance there were no obvious reasons why that should be so. The fact remained that, before the war, the Belgian foundries were able to import hematite from Great Britain, convert it into steel castings, and undersell the British foundries in their own markets.

As a result of careful study of the Belgian steel casting industry, by personal observation and inquiries in that country itself, Mr. Lange came to the following conclusions as regards the cause that led to its success:

1. The excellent organization and equipment of the steel foundries.
2. The suitability of the small converter for making small and medium weight castings, as shown by the fact that the output of steel castings in Belgium has quadrupled itself in the last twelve years.
3. The advantage of no artificial restraint of the production on the part of the trade unions, i.e., the advantage of working piecework instead of day work.
4. The fact that small converter castings require smaller casting heads and runners than with the open hearth process.
5. The castings require less annealing.
6. The Belgians have an abundance of cheap natural moulding sand, particularly suitable for the small converter process.

PROCESSES IN MANUFACTURE

Inventive Genius and Research Operate to a Dual End—They Aim to Improve What We Now Possess and Bring to Our Service Commodities Before Unknown

COATING IRON AND STEEL WITH ZINC-GALVANIZING—I.*

By W. Ellison Sharples, M.I.S.I.

THE object of this paper is to deal with the subject of coating iron and steel with zinc or, as more generally termed in the commercial world, galvanizing. Owing to the great conflict waging in Europe this industry, from a purely commercial point of view, has been considerably curtailed. In normal times it is a large and extremely important industry. In the last generation the galvanized iron trade has developed enormously. There is no doubt that zinc is the best rust preventative for iron and steel, but it is not altogether on account of its cheapness that it is so extensively used, as there are other metals which are cheaper and less corrosive than zinc. If zinc did not corrode it would be useless for the purpose for which it is used.

When iron or steel, having been coated with zinc, is exposed to the atmosphere, a galvanic action is set up, although extremely slight. Any two dissimilar metals form a galvanic couple, but zinc being "electro-positive," the zinc suffers corrosion at the expense of the iron, which is the "electro-negative" metal. The effect is that, providing there is any zinc left upon the iron, the corrosion goes on exclusively with the zinc, the iron or steel not being corroded at all.

The oldest galvanizing process and the one most generally used is the hot or dipping process. The cold or electro and the Sherardizing processes are also used to a considerable extent, and they have gained ground in the last few years. The hot or dipping process is used exclusively for the coating of sheets, and consequently it will perhaps be well to deal with this branch of the galvanizing industry first. An idea of the immensity of this branch of the industry may be gathered when we consider that the production of this commodity, which in the year 1895 was two hundred and four thousand tons (204,000), by the year 1907 had grown to a production of four hundred and ninety-seven thousand tons (497,000). The chief consumers of this commodity are Australia, South Africa, Argentine and India.

The term galvanized iron is one which for many years has been given to articles of iron coated with zinc, for the purpose of preserving the iron from oxidization by the atmosphere. When iron is thoroughly cleaned and freed from scale, it will, upon being dipped into molten zinc, become perfectly coated. If the iron is perfectly coated the atmosphere has no direct action upon it,

but a thin film of oxide is formed upon the zinc coating.

Quality Feature

The quality of the galvanized sheet depends chiefly upon three things. Primarily, on the quality of black sheet iron—that is the sheet iron as it comes from the rolling mills—and upon the care exercised during the process of galvanizing. If the quality of sheet iron is poor, even a heavy coating of zinc will not produce a good sheet. It is essential that the sheet iron be absolutely clean and free from scale and cinder, otherwise it will not hold the zinc coating for long, and after a short time of exposure to the atmosphere spots of rust will appear, which eating into the surface expose the iron to rapid oxidization and corrosion. Secondly, the quality of the iron as regards ductility and toughness must be studied, for, if it is not sufficiently so, it will, on being corrugated, crack, and although the fissures may perhaps be so small as to escape a cursory examination, they will, on being exposed to the action of the atmosphere quickly corrode and render the sheet practically worthless. Thirdly, the quality of the finished iron depends to a very large extent upon the purity of the spelter used—spelter is the name given in commerce to the zinc blocks before being made into zinc sheets.

Dipping Only

When the trade was first established, the process universally adopted was that of dipping, no machinery being used. The bath employed was about 9 ft. long by 3 ft. 6 ins. wide by 4 ft. deep. A bar of "T" iron upon which was riveted an iron plate, just deep enough to go into the molten metal, when the bath was at its lowest working level, was placed across the middle of the bath. The object of this was to divide the flux and keep the exit side in the best condition. A dipper and his mate were employed at the entrance side, and they together plunged the sheet into the molten metal, and by means of rods passed it under the iron plate before mentioned, bringing it up on the other side of the same through the flux. The sheet was then seized by "takers out"—two being employed—who gradually drew it out by means of tongs, and when the surface was sufficiently set plunged it into a tank of clean water. Afterwards the sheet was passed to the sawdust boxes, where it was dried. If it was desired to have a bright sheet, it was plunged into water before crystallization had begun. It was tried, with a view to economy in flux—that is, sal ammoniac, or muriate of ammonia as it is generally known in the trade—to utilize black foundry sand. It is apparent to anyone conversant with

the process of galvanizing what a terrible practice this was, seeing that sand is not a fluxing agent for zinc. Its only economy, and that an imaginary one, was that due to the sand dragging on the surface of the sheet it would act as a flux. It created a large quantity of sand skimmings and oxide, besides the difficulty of separating the spelter and the sand when in a fine state. Several patent processes were introduced, among them being Heathfield's, Baylis's, and Carasco's.

Heathfield's Process

In this process a machine having several pairs of rolls was employed, the last pair being just above the surface of the metal, the object being to squeeze the surplus zinc off the sheets and give a uniform coating.

Baylis's Process

In this process the sheets after being pickled were passed through a pair of cold rollers upon which flowed a continual stream of water. From these rollers the sheet passed on to a bath which it entered by means of a pair of rollers fixed on the bath frame. It then passed by means of guides through the metal and emerged through the flux, which in this process was sand. They were then seized by a pair of studded rollers, passing onwards by means of an endless chain to a set of revolving brushes which brushed off the adhering particles of sand.

Carasco's Process

In this process the sheets passed through a pair of rollers on the bath and were conducted by means of guides into the flux box. From the flux box they passed by means of other guides through the metal and emerged through a pair of V-shaped wheels which gripped the sheets on the edges.

We now come to the process as carried out to-day and will deal with the machinery more fully.

Buildings

A building with a framework of light sectional iron and covered in either with asbestos, slates or corrugated iron sheeting serves the purpose equally as well as costly wood or brick buildings. Care must be taken to have a periodical inspection of the ironwork, and it should also frequently be coated with some good anti-corrosive paint, of which there are several upon the market. In arranging the buildings, the fact should not be overlooked that it is better to have the sheds used for corrugating, sorting and packing separate and detached from the galvanizing and pickling sheds. Attention also should be given to the ventilation of the buildings, especially in the case of the corrugating, sorting and

packing sheds, and they should also be heated to obtain a dry atmosphere. This can be done by means of hot air heated by a steam heater, or a waste-coke heater, of which there are plenty in works of this kind.

Pickling

This is the first stage of the process after receiving the sheets from the annealing furnaces. There are two classes of acid used in this work, either sulphuric or commercial hydrochloric. If the former, the specific gravity used is 1.8 or 1.9 and mixed in the proportion of five parts of water to one of acid. In using this acid it is necessary to quicken its action upon the sheets by warming it to a temperature of about 90° to 95° F. by means of a steam jet, which conveys the steam to about 2 ins. from the bottom of the vat by means of a lead pipe of about 1/2-in. bore.

If hydrochloric acid is used as the pickling agent a "Twaddell" of about 35 is employed and the proportions are one of water to one of acid. By using this acid, it is, as a rule, unnecessary to warm it up by means of steam except in cold weather.

Of course, the adoption of acid used for pickling depends to a certain extent upon local conditions, but, speaking generally, it is preferable to use hydrochloric acid, since the sheets do not require soaking after pickling; although a water-vat is often provided so that when the sheets are taken out of the pickling vat, to await being dipped by the dipper, they may be put in the water vat to await dipping, thus ensuring that they are kept perfectly clean. The fumes generated by the hydrochloric acid pickle are not so annoying as those generated by the sulphuric pickle. The working cost of both pickles is approximately the same due to the different quantities of acid used. The time occupied in pickling a batch of sheets is approximately the same under both systems and varies from 15 to 20 minutes, according to the condition of the iron and also of the pickle.

Pickling Vats

These vats are best constructed of good York stone, the vertical joints being joined together by means of solid round indiarubber pulled tightly together by means of clamps and rods. In the opinion of the author, clamps are better dispensed with. It is only necessary to drill the flags and pass the tie-rods through them direct. The horizontal joints are best made with flannel well smeared and kneaded with a paste of white lead and boiled oil. This prepared flannel is then evenly laid upon the portion of the stone which has already been truly dressed for the purpose. The side flags are then laid upon this flannel, their weight being found sufficient to close the joints securely. If care is taken in the building up of these tanks, they will last for many years with very little attention. Owing to the continual charging and discharging of the vats with sheets some protection is necessary for the tops of the vats. A cheap

and efficient method of overcoming this difficulty is to protect them by means of channel iron, the wear being taken by this iron. This will be found to well repay the extra outlay, as the renewal of a stone side is a somewhat costly job. The bottom of the vat is protected by blue bricks set in china clay and pitch, about two courses deep. A hole about 3 ins. diameter for emptying the vat is provided at one end of the vat, being plugged up by means of a wooden taper plug covered with flannel. A cheaper vat can be made of pitch pine lined with lead and its bottom protected by means of elm or pitch pine planks wedged in to prevent the sharp edges of the sheets-cutting the lining.

Although the initial cost of the stone vats is far in excess of the wooden ones, their life is considerably longer and the maintenance is not so high. All tie rods and clamps should be regularly and frequently coated with a mixture of equal parts of lime and tar, when it will be found that they will last a considerable time, although often being splashed with acid.

The second or intermediate vat is generally constructed of pitch pine planks whose top sides are likewise protected with channel iron to prevent wear due to the rubbing action of the sheets. The sheets after being fed into this vat from the pickling vat by manual labor are, in some cases, fed into rollers fixed on the side of this vat, and thus conveyed into the dipping machine; but it is, in the author's opinion, better that the sheets be taken by hand from this vat and fed into the dipping machine by the dipper, thus ensuring a square start and a safer passage of the sheet through the galvanizing bath.

Bath and Bath Frame

The bath is made of the best quality mild steel plates 1 in. to 1 1/4 ins. thick, being either riveted or welded, a convenient size being 5 ft. 9 ins. by 5 ft. 9 ins. by 3 ft. 6 ins. deep. This is set upon a foundation of brickwork covering the whole of the bottom, rising about 9 ins. round the sides, so as to prevent, as far as possible, the bath being burnt when the dross accumulates at the bottom.

These baths are fired by various means, generally open coke fires, or the bath may be surrounded by means of cast iron covering plates over the fires, with suitable firing holes cast in them, having suitable lids, so that the intensity of the fire may be regulated. These plates are best cast in angle form and bolted together in such a manner that they may form a fixing or stay for the brickwork, at the same time being easily removable in the event of the bath becoming leaky, necessitating immediate and quick repair. Great care is needed in the firing of the bath, as upon this depends to a very large extent the life of the same. For successful working it is necessary to maintain an even heat in the bath so as to prevent undue formation of oxide caused by overheating of the metal on the one hand, and excessive deposit of metal on the sheets caused by too low a heat on the other hand. The

temperature to aim for is from 830° to 850° F., which will give a satisfactory result. Care should be taken to instruct the dipper, and likewise to see that the instruction is carried out, that he must clean daily the sides of the bath on the fire side and internally, as far as possible of oxide creepings by means of a scraper bar. This considerably helps in prolonging the life of the bath, preventing overheating of the same—as oxide is an exceptionally bad conductor of heat and when formed and allowed to remain causes burning of the plates and ultimate failure of the bath.

Starting a New Bath

When the galvanizing bath has been properly set, considerable care must be exercised in filling it with spelter to prevent the bath from being ruined when the fires are started. In filling the bath with slabs of spelter, place them on edge in such a way that their flat surface will lie as closely as possible to the sides of the bath. By exercising a little ingenuity the slabs can be so placed as to practically cover the sides of the bath. This method of placing the slabs will lessen the danger of burning the bath on the first firing as there is cold zinc against all the heated surface. The slabs should also be arranged so that as the outside ones melt, those next to them will be forced outward against the side of the bath.

Firing a New Bath

In heating up the bath for the first time, one should take care that the work is not hurried. Under no circumstance attempt to melt out a bath for the first time in less than 36 hours. Until spelter begins to melt the fuel should not be allowed to attain a depth of more than 12 or 15 ins. in the fire spaces, and the air holes should be regulated so that the fires will not burn so strongly. As the metal melts the depth of fuel may be increased, but it should never be more than 3 or 4 ins. above the surface of the metal in the bath. Of course, it is rather difficult to determine just the depth of the molten metal, but it is easy to be on the safe side even if a longer time is taken in melting out.

Leaky Baths

It often happens that a bath is worn more in one particular place than another. This is often caused by draughts forcing the fire in that particular spot, but by careful stopping it is possible to considerably lengthen the life of a bath. All repairs should be carried out in a careful manner, and as quickly as possible consistent with first-class repairs.

The location of a leak soon makes itself apparent by excessive fumes due to oxidation of the metal. The first operation is to remove the fire and ashes from the vicinity of the leakage when the size of the same can be observed. No attempt should be made to stop the leak by thrusting the point of a poker in the hole, as this may cause the hole to become larger, especially if the plate has become very thin in this particular place. If the hole is very small it can be stop-

ped, but if the molten spelter flows in a continuous stream it is necessary to lower the level of the metal below the level of the hole. If the hole is large the metal can be caught in moulds while the operation of lowering is going on.

The next step is to build up from the bottom of the fire space a column of fire-brick to within a foot of the hole. A piece of R.S. channel about 5 ins. by 3 ins. is then put in an upright position and tightly wedged to the bath from the brickwork and the brick column is built up to the level of the surrounding brickwork. In the intervening space, formed by the channel, some fireclay, made into a stiff paste, is put and well rammed, so as to form a good foundation, which should reach to within 5 ins. of the hole. A mixture of iron filings and sal-ammoniac is then put in on the top of the fireclay and also well rammed until it is a few inches above the aperture. The remainder of the space so formed is then filled in with fireclay and well rammed. This should be allowed to remain a couple of hours to set, when the bath may again be put in service.

GOOD BUSINESS ORGANIZATION

By Geo. H. Gibson

GOOD business has been defined as the art of selecting probabilities, and it is certainly true that the greatest successes in the engineering businesses have come to men who had the ability to do the following things: Foresee the need or opportunity, develop the solution, and focus the attention of the public upon the problem and its solution. As examples, I might mention Edison with the incandescent lamp, Westinghouse with the air brake and alternating current transmission, Hunt with rope transmission, Sturtevant with fans and blowers, De Laval and Parsons with the steam turbine, Babcock and Neier with the water-tube boiler, Diesel with the oil engine, the Wheelers with surface condensers, Hill with technical journalism, Thurston with technical schools, Patterson with the cash register, Herschel with water meters, Kent with his handbook, and many others.

The inertia and prejudice which must be overcome in the introduction of a new device may be illustrated by the experience of Corliss with his variable cut-off four-valve steam engine. After he had perfected and demonstrated the remarkable savings of his engine as compared with the engines then common in this country, he was still compelled to give the engines away and to take his payment in the fuel saved during the first year's operation, in order to make headway.

Many people have the idea that the invention is the important thing. Very few engineering businesses, however, are founded altogether on exclusive and basic patents. They are based rather on a combination of scientific knowledge and business sagacity, with the help of such protection, monopoly or trading advantage as can be obtained from the detail patents which it may be possible to secure as the development of the

art unfolds itself. A man may have the germ of a good idea for a successful business, but still nothing that can be protected by a patent, even though patentable improvements will doubtless be discovered upon developing the idea. Nevertheless, the essential factor is the broad judgment or foresight which leads him to take up certain matters at a particular juncture, and not the specific mechanical contrivances by which he may carry out his ideas. In such cases, the best protection to the idea is advertising by means of which he can promptly get the full benefit of the potential demand for his product before competitors have had time to imitate and develop. Once he has his organization and business well under way, competition will be at a disadvantage.

For businesses up to a certain size, there is nothing that will beat one-man efficiency. The man who can see a need or an opportunity for a need, and act accordingly, is fit to be the head of a business, if he is also an administrator. However, the organization of modern industrial enterprises branches out into a great multiplicity of specialized details, and we cannot always get in one man all those qualities of genius that are necessary in the inventor, in the captain of industry, and in the promotion expert. We therefore have performing these functions a number of men who may be described as follows:

First, there is the general strategist, who may have the title of president general manager, chief engineer, and not infrequently sales manager, since the study of how to sell a product as already built leads almost invariably to the discovery of improvements whereby it can more easily be sold in larger volume and at a greater profit. It is his disposition and function never to be satisfied with things as they are. He is continually studying the trend of engineering scientific and business developments with a view to visualizing their probable future course. His policy is to build a monopoly of information and brains, and then to serve the public with little or no competition by having the best solution for each new problem as it arises.

PYROMETER DEVELOPMENTS

(Continued from page 312.)

instrument, so that when a balance is reached, no current flows. A galvanometer is used to indicate the point at which no current is flowing, and the pointer on the galvanometer then indicates zero, the voltage of the thermo-couple being opposed to the dry cell. The advantage of the potentiometer method of measuring temperature lies in its extreme precision, and its independence of resistance changes throughout the thermo-couple circuit. It has the disadvantage compared with the millivoltmeter method in that it is not direct reading, and that some outside source of current, a dry cell for example, is necessary as a source of current to oppose the thermo-couple.

Radiation Pyrometers

The radiation pyrometer is a development of the thermo-electric pyrometer. Instead of placing the thermo-couple inside the furnace, where the temperature would be so high as to destroy it, it is placed in the back of a tube in front of a mirror. The rays of heat from the furnace enter the tube and strike the mirror and are brought to a focus on the thermo-couple junction. This instrument has a particular field where temperatures must be measured from 2,800 degrees Fahr. up, and it is possible to secure an accuracy within 1 or 2 per cent. with this type instrument, if the instructions as to its use are properly carried out. It is not recommended for service where a thermo-electric pyrometer with base metal or platinum thermo-couple can be used.

It is very essential if accurate results are to be secured from pyrometers that they be re-standardized at frequent intervals. The freezing point of pure salt is an excellent method of testing thermo-couples, or of the complete pyrometer consisting of the thermo-couple, leads and instrument. Insert a thermo-couple in a small crucible containing pure salt; ordinary table salt is satisfactory and heat the salt to about 1600 degs. Fah. Remove the crucible from the heat and allow it to cool off. At the freezing point of the salt which will be indicated by the temperature remaining reasonably constant for four or five minutes, the pyrometer should read 800 degs. Cent., or 1,472 degs. Fah. The melting point of a number of different metals is quite satisfactory for checking purposes.

The metals most generally used for this purpose, and their melting points follow: Tin, 450; zinc, 787; silver, 1,761, and gold, 1,945; copper, 1,929; aluminum, 1,157, and platinum, 3,227 degs. Fah. The Bureau of Standards at Washington tests pyrometers and thermo-couples for manufacturers in the United States, and it is a good plan to have a standard platinum or base metal thermo-couple tested at the Bureau since its laboratories can furnish the millivolt values for the thermo-couple. This data can be retained as a primary standard to test the secondary thermo-couple. The cost of such a test is usually about \$10.

Automatic Temperature Control

The greatest future in pyrometry undoubtedly is along the line of automatic temperature control. Instruments which automatically control the temperature of electric furnaces have already been designed. By means of solenoid operated switches the circuit is opened and closed through the rheostat, maintaining the temperature constant within 10 degs. Fah.

It may be suggested that the various steel manufacturers who are interested in the improvement of heat treating methods can be of great assistance to pyrometer manufacturers in co-operating with them to test out new devices in an endeavor to improve on present methods.

PROGRESS IN NEW EQUIPMENT

A Record of New and Improved Machinery and Accessories for the Machine, Pattern, Boiler and Blacksmith Shops, Planing Mill, Foundry and Power Plant

WHAT is claimed as the largest machine of its type now on the market is shown in the cut here, shown in the accompanying engraving, which illustrates a recent product of the Gardner Machine Co., Beloit, Wis. The No. 15 double spindle grinding machine carries 20 in. ring wheels or 24 in. disc wheels both of which types of grinding members are interchangeable.

Each spindle is mounted in a sliding head which in turn moves in an adjustable sub-base which can be securely fastened in any desired position according to the requirements of the work. The cast iron hoods which guard the wheels are fastened to the inner ends of the sub-bases and move only when these are adjusted for position. The sliding heads work through a felt lined hole in the hoods and have a combined lateral travel of 3 1/2 in. when both heads are moved toward the centre simultaneously; either head, however, may be locked in position and one head only moved. As shown in the engraving the sub-bases are set well apart for grinding opposite sides of very wide pieces, but when grinding thinner articles the sub-bases are moved closer accordingly and secured to the bed by bolts. This adjustment is conveniently made by pinions carried in brackets attached to the sub-base and engaging with a feed rack which extends across the front of the bed, a detachable wrench being used for this purpose.

The feeding of the heads is done by a vertical shaft at the left of the ma-

horizontal hand lever is mounted on the upper end of the vertical shaft. When this hand lever is pulled to the right the feed bar moves to the left and revolves

the hand feed shaft by bevel gearing so that the operator may control the machine from either side of the work.

At the extreme left of the feed bar is a stop screw against which the feed bar abuts when the heads are fed in. A worm nut adjusts this hardened screw, and is acted upon by a worm on an inclined shaft which terminates directly behind the hand lever with a small graduated hand wheel. A back stop is also provided for limiting the backward travel of the head.

The work table slides in and out between the wheels and is provided with tee-slots and holes for fastening fixtures in place for holding the

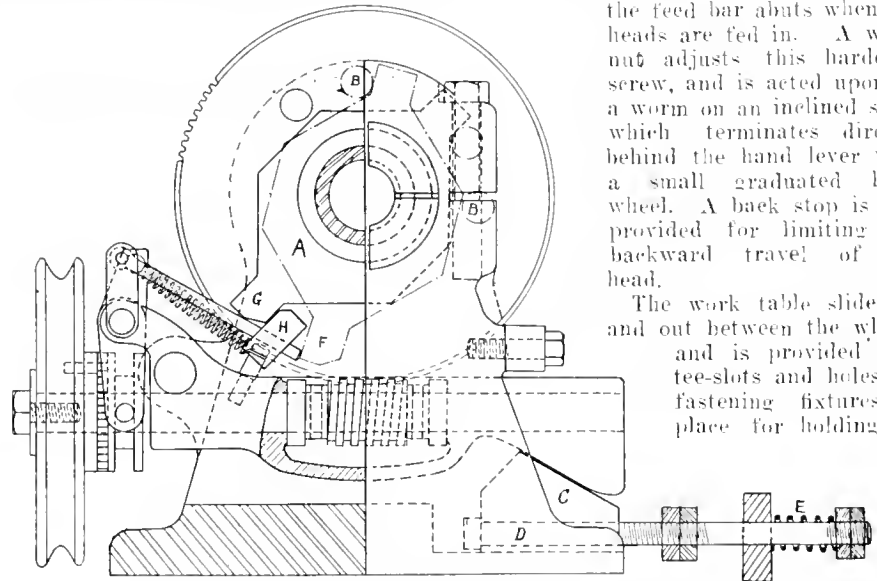

HALF SECTIONAL ELEVATION OF WORK-HOLDING DEVICE FOR THREAD MILLING ATTACHMENT.

the pinions meshing with the rack on its upper surface. The shafts on which the pinions are mounted transmit the motion through suitable bevel pinion gearing to spur pinions which mesh with racks fastened to opposite sides of the sliding heads so that the heads move

work. It is moved back and forth by rack and pinion operated by hand lever at the left side of table. This lever is attached to a large gear which meshes with a pinion on the outer end of the rack pinion shaft. When a slower and more powerful movement of the table is required, the gear and pinion are reversed. The shaft carrying the hand lever is extended across to other side of bed from which it can be operated if desired. The entire base of machine is cored out with solid bottom and connected with the water basin in front of table giving a capacity of 70 gals. of lubricating compound. Grinding may be done either wet or dry; when dry, a covered opening in the rear of machine directly behind the sliding work table is provided for attaching dust exhaust system. Nett weight of machine is 5,000 lbs. and the maximum opening between disc wheels is 24 in., and between ring wheels 20 in.

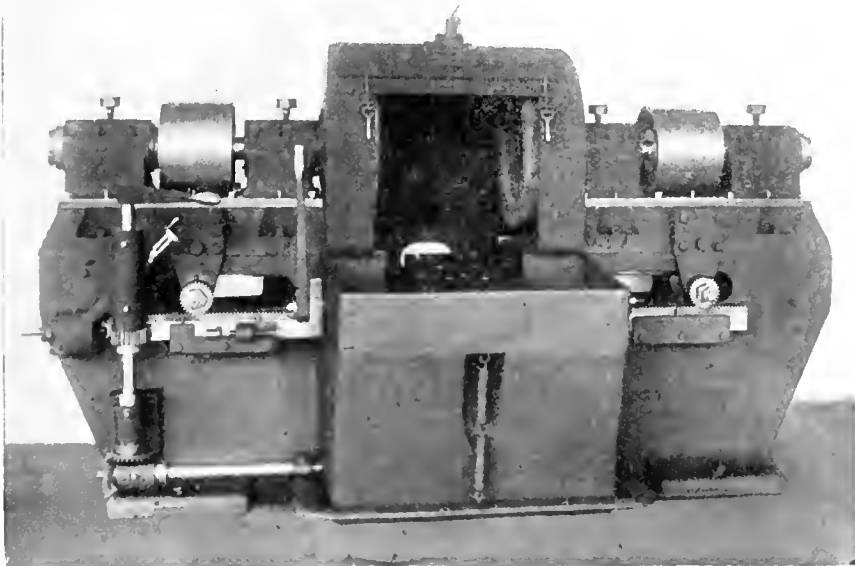

HEAVY DUTY DOUBLE GRINDER.

chine. A pinion on this shaft engages with a short length of rack on front of the 3 in. square steel feed bar, and a

in opposite directions or to and from each other. A treadle extends around the front of the machine and operates

SEMI-AUTOMATIC THREAD MILLING APPARATUS

THE accompanying illustrations show a thread milling device which has been developed in connection with munitions manufacture, and is now being placed on the market in a form adapted for inside or outside milling, and for any pitch up to 1/2 in., either right or left hand. It is used with a multiple tooth, straight relieved cutter, and finishes work at one revolution. Where a final finishing cut

is required, the spindle by changing one screw will automatically make two revolutions, one for roughing and one for finishing.

The attachment will fit any hand or screw feed milling machine, and where a greater angle is being cut than can be taken care of with the clearance of the cutter, the apparatus can be raised or lowered so that the cutter will be directly underneath or on top of the work, allowing the cutter to be set at the proper angle to clear the threads. The principal features are a work carrying spindle carried in a suitable casting and provided with means for revolving it and feeding it axially according to the required pitch. The spindle has a collet capacity of 1 3/4 in. on pieces not more than 4 in. long, and has a 1 in. hole clear through. The portion containing the collet is mounted in the main bearing of the frame, while the portion extending backward has mounted on it a worm wheel and stop mechanism, and also a lead screw, which engages with a nut carried in the rear spindle support.

The worm for revolving the spindle is carried in a swinging bracket, the arrangement of which is clearly shown in the line drawing. It is driven by a rope pulley with dog clutch which automatically engages when the worm is meshed with its gear. This latter operation occurs when the table is fed by hand when the rod D is held by a bracket attached to a stationary part of the machine, causing the wedge block C to raise the free end of the worm shaft and engage the worm with worm wheel. A stop plate A revolves loosely on the hub of this gear and is stopped by the two pins B.B, two positions for which

C and allow worm to drop. The spring E is provided to bring the worm into mesh and start the work revolving before the cutter is in contact, the compression of the spring allowing further forward motion to full depth of cut.

After a piece is removed, the stop plate returns to point G through the action of screwing up the collet. The machine is automatic in the actual milling of the thread and produces work to the usual high degree of accuracy obtained with thread milling machines. The American Ammunition Co., Bordertown, N.J., are the makers of this attachment.

HYDRAULIC JOINT PACKING

IN a recent issue of the *Philosophical Magazine* the Earl of Berkeley and Dr. Burton describe a simple form of joint packing, which is, they state, tight to start with and maintains this tightness

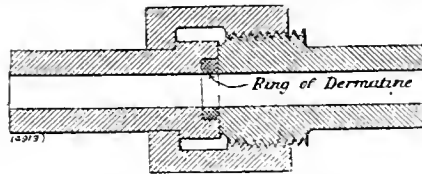

HYDRAULIC JOINT PACKING.

up to the highest pressures they have employed, and which have attained 1,500 atmospheres, or say, 10 tons per square inch. As will be noted from the accompanying sketch, the pipe ends are faced, and a recess is cut in one to take the ring of dermatine shown. Before assembly, this stands just a little over, and is thus slightly compressed when the joint is tightened up. Either red or black dermatine may be used, but the red, being harder, is more easily ma-

bands formed of leather or other soft material are provided, the idea being that same will not injure the barrel of the gun, thereby greatly lengthening its life, and at the same time providing an efficient gas check. The band is shown

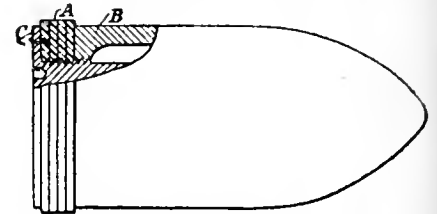

FIG. 1.

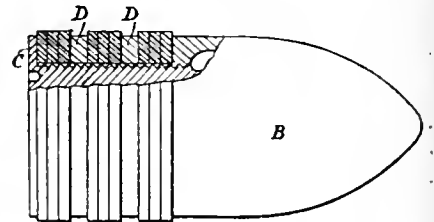
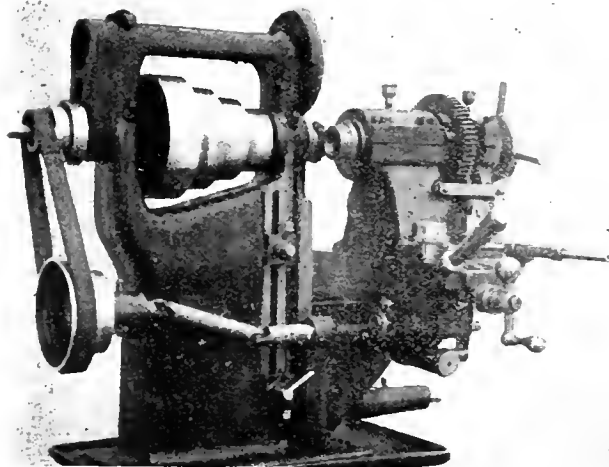
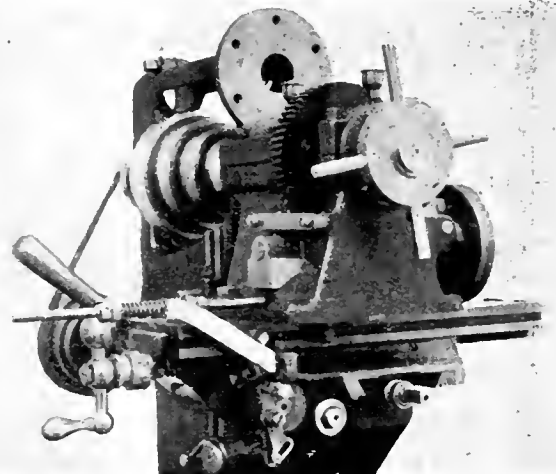

FIG. 2.

in Fig. 1 by a single ring A of leather between the body of the shell B and a clamping ring or plate C, which may either be threaded as shown, and screwed into place, or be formed as a plain ring or disc adapted to be adjustably held by screws or bolts, so as to permit the pressure of the gases when exerted on the back of the ring or plate to further expand or compress the ring A into close contact with the bore of the gun as the shell is ejected. The ring A may be formed of a single layer of leather if desired, or, as shown, of several layers



VIEW OF THREAD MILLING ATTACHMENT SHOWING CUTTER WORK IN CHUCK, AND END OF STOP PLATE ON SPINDLE.



VIEW OF THREAD MILLING ATTACHMENT SHOWING FEED ROD WITH SPRING AND STATIONARY ARM.

are shown, the amount of revolution obtained being about one and one-tenth.

The action of tightening up the collet brings plate A to the position shown by the full lines, point G being against stop H. The revolving of the work brings the plate into position shown by point F which contacts with a push rod to disengage drive clutch on worm shaft. On running the table back again, stop nuts on rod D release wedge block

chined. The joint is said to be equally good for water or oil, and is as suitable for a flanged joint as for a screwed coupling. It is also said to be as satisfactory with large pipes as with small.

NEW FORM SHELL

THE sketch Figs. 1 and 2 represents a new form shell invented by Stanley Frederick Stokes, Chatham, England, (103,270), in which one or more rifling

arranged together side by side before the single plate C. If desired, a metal plate of smaller diameter could be arranged at intervals, such as between each layer of leather, so as to divide the ring A into several narrow bands. Or, again, several wide bands may be provided, as shown in Fig. 2, each of which is composed of several thicknesses of leather or like soft material, and separated by means of plates of metal D.

The MacLean Publishing Company

LIMITED

(ESTABLISHED 1888)

JOHN BAYNE MACLEAN President
 H. T. HUNTER Vice-President
 H. V. TYRRELL General Manager

PUBLISHERS OF

CANADIAN MACHINERY AND MANUFACTURING NEWS

A weekly newspaper devoted to the machinery and manufacturing interests.

PETER BAIN, M.E., Editor. B. G. NEWTON, Manager.

Associate Editors.

A. G. WEBSTER, J. M. WILSON, J. H. RODGERS.

Office of Publication, 143-153 University Avenue, Toronto, Ont.

Vol. XVII. MARCH 29, 1917 No 13.

INDIVIDUALITY OR CO-OPERATION?

THE probable effect which a declaration of war by the United States will have on Canadian industries is the subject of much speculation and at the same time of no small concern to many of our manufacturers apart from those engaged in munitions making. In a crisis like that through which our Southern neighbor is now passing, exaggerated reports and vague possibilities are too readily accepted by a public accustomed to sensational statements whose chief feature is magnitude.

Every loyal Canadian from munition worker to railroad magnate must experience some disquietude when reports are circulated indicating the probable action of the States in such matters as prohibiting the export of raw war materials. In view of the peculiar attitude adopted by our neighbors as they approach actual participation in hostilities, it is reasonable to ask whether they cannot help themselves more by extending the existing channels of help, rather than by endeavoring to enter the war as a self-contained semi-detached nation which wants to go on record as having fully equipped itself with every species of modern war machinery, made in America.

In view of the silent but none the less powerful influence of Great Britain in unexpected quarters, it is difficult to give credence to such reports as those which state that numerous ships being built in the States for British interests would be commandeered in case of war. The only nations on earth that the States can trade with are or ought to be those of the Allies, and such trading is done under the protection of the British navy. What benefit would accrue either to the States or the Allies from the taking over of ships now in course of construction?

The question of holding back material is almost parallel to the above in its unjustifiableness. While there is doubtless room for many more shells before an adequate reserve is available for defence against Mexico, the possible damage to the Allied cause from such a source is not to be compared with the handicap that would ensue through a

serious restriction of Canadian output. What, we might ask, would have been the situation in Europe to-day if Britain had decided that all her coal and iron were needed at home?

It is just possible that the obsession for organization which is such a prominent feature of U.S. business to-day may act to obscure the real issues of the war, and result in shortsighted action, which, while directed toward the magnification of our neighbors' preparedness, will on the other hand be comparatively useless, if not actually harmful, although unintentionally so, to the Allied cause.

The absence of any official action tending to bring these and similar contingencies to a point for decision renders it impossible to forecast developments with any degree of definiteness. It is significant, however, that a clause has been inserted in certain war office contracts in Canada forbidding the employment of labor outside the Dominion. Raw material and machinery are the principal needs of Canada at this time so far as the States are concerned, and any hurtful restrictions on these commodities will have to be justified by very extreme conditions not at present in evidence, if the participation of the States is for the benefit of the Allies as a whole rather than the United States individually.



STANDARDIZING MARINE ENGINE DESIGN

IN VIEW of the development taking place in shipbuilding and marine engineering within our borders, it may be of interest to note that quite definite steps have been taken in Great Britain in the direction of standardizing not only vessel construction, but that of the propelling, and in some instances, the auxiliary machinery as well. In another section of this issue will be found an article entitled "Guidance Specification for Triple Expansion Marine Engines for Cargo Boats," the compilation of which is to the credit of the Council of the North East Coast Institution of Engineers and Shipbuilders. With the prospect of several years activity ahead for marine enterprise in Canada, and the certainty that many of our metal working plants will find opportunity of participating in one or other of its departments, the fullest intimacy with the plans and projects in preparation and already launched is, to say the least, highly desirable.

The standing of the North East Coast Institution of Engineers and Shipbuilders is first rank, therefore its proposition for a greater uniformity of marine engine design and construction carries a powerful appeal. It is perhaps needless to say, that more or less difference of opinion is likely to be given expression to as regards some of the proposals put forward in the article, nevertheless, having in view the extreme dearth of shipping, and the imperative need that it be promptly remedied, there is little doubt that a common ground with but slight modification of the original proposals, will become acceptable to the various interests concerned. Canadian marine engine builders—actual and prospective, also those more directly concerned with the operating service, will find, in the data presented, a safe and reliable groundwork from which to create and develop a propelling machine at once substantial and utilitarian.



The Annual Report of the South African National Union says "Our motto should be to export nothing in the raw state which can profitably be converted into another article of higher value before it leaves our shores. This applies with equal force to agricultural products and the mineral wealth of the soil." A similar motto should be adopted by Canada.

SELECTED MARKET QUOTATIONS

Being a record of prices current on raw and finished material entering into the manufacture of mechanical and general engineering products.

PIG IRON.

Grey forge, Pittsburgh...	\$32 95
Lake Superior, charcoal, Chicago	36 75
Standard low phos., Phila-	
delphia	70 00
Bessemer, Pittsburgh	37 95
Basic, Valley furnace.....	32 00
Montreal Toronto	
Middlesboro, No. 3.	
Cleveland, No. 3	
Clarence, No. 3	
Hamilton	42 00
Victoria	

FINISHED IRON AND STEEL.

Per lb. to Large Buyers Cents	
Iron bars, base, Toronto..	4 25
Steel bars, base, Toronto..	4 50
Steel bars, 2 in. to 4 in. base	6 00
Steel bars, 4 in. and larger base	7 00
Iron bars, base, Montreal..	4 25
Steel bars, base, Montreal..	4 50
Reinforcing bars, base ...	4 05
Bessemer rails, heavy, at mill	38 00
Steel bars, Pittsburgh.....	3 75
Tank plates, Pittsburgh.....	5 25
Beams and angles, Pitts-	
burgh	3 40
Steel hoops, Pittsburgh ..	4 00
F.O.B. Toronto Warehouse	
Steel bars, base	4 50
Small shapes	5 00
F.O.B. Chicago Warehouse	
Steel bars	4 00
Bars, 2 in. and up	4 40
Structural shapes	4 25
Plates	5 50

FREIGHT RATES.

Pittsburgh to Following	Points
Per 100 lbs	C.L. L.C.L.
Montreal	23.1 31.5
St. John, N.B.	35.1 45.5
Halifax	35.1 45.5
Toronto	18.9 22.1
Guelph	18.9 22.1
London	18.9 22.1
Windsor	18.9 22.1
Winnipeg	64.9 85.1

METALS.

Montreal Toronto	
Lake copper	\$43 00 \$40 00
Electro copper	43 00 40 00
Castings, copper	40 00 39 00
Tin	56 50 56 00
Spelter	15 50 14 00
Lead	12 25 12 25
Antimony	30 00 35 00
Aluminum	70 00 68 00

BOILER PLATES.

Montreal Toronto	
Plates, 1/4 to 1/2	\$6 50 \$6 50
Heads	6 85 6 85
Tank plates, 3-16 in. 6 00	6 00

WROUGHT PIPE.

In effect March 5, 1917.	
Per 100 feet—	Black Galv.
Buttweld.	
1/4 in.	\$ 4 50 \$ 6 00
1/2 in.	2 78 5 91
3/4 in.	3 78 5 91
1 in.	4 93 6 50
1 1/4 in.	6 10 8 22
1 1/2 in.	9 01 12 16
2 in.	12 19 16 45
2 1/2 in.	14 58 19 66
3 in.	19 61 26 46
3 1/2 in.	31 01 41 83
4 in.	40 55 54 70
4 1/2 in.	50 00 67 62
5 in.	59 95 80 12
Lapweld.	
2 1/2 in.	22 57 29 05
3 in.	33 92 44 17
3 1/2 in.	44 37 57 76

3 1/2 in.	55 20	72 22
4 in.	65 40	85 57
4 1/2 in.	76 20	99 70
5 in.	88 50	116 20
6 in.	115 20	150 70
7 in.	152 30	196 40
8 L. in.	160 00	206 30
8 in.	184 30	237 60
9 in.	220 80	284 60
10 L. in.	204 80	264 00
10 in.	263 70	339 90

Prices Ontario, Quebec and Maritime Provinces.

WROUGHT NIPPLES.

4" and under, 60%.
4 1/2" and larger, 55%.
4" and under, running thread, 40%.
Standard couplings, 4" and under, 50%.
4 1/2" and larger, 30%.

OLD MATERIAL.

Dealers' Buying prices.		
Montreal Toronto		
Copper, light	\$24 00 \$24 00	
Copper, crucible	28 00 28 00	
Copper, heavy	28 00 27 50	
Copper wire	28 00 28 00	
No. 1 machine composition	23 50 22 00	
New Brass clip-pings	19 00 18 00	
No. 1 brass turn-ings	16 00 17 00	
Heavy Melting steel	16 00 16 00	
Steel turnings.....	12 00 9 00	
Boiler plate	15 00 10 50	
Rails	17 00 15 00	
Axles, wrought iron		21 00 24 00
Rails	17 00 18 00	
Malleable scrap	15 00 11 00	
Pipe, wrought	12 50 9 00	
Heavy lead	9 00 10 00	
Tea lead	7 50 6 50	
Scrap zinc	9 00 10 00	
Aluminum	36 00 35 00	

BOLTS, NUTS AND SCREWS.

Per Cent.	
Coach and lag screws	30
Stove bolts	55
Plate washers	10
Machine bolts, 7-16 and over	10
Machine bolts, 3/8 and less.	20
Blank bolts	10
Bolt ends	10
Machine screws, fl. and rd. hd., steel	27 1/2
Machine screws, o. and fil. hd., steel	10
Machine screws, fl. and rd. hd., brass	add 20
Machine screws, o. and fil. hd., brass	add 25
Nuts, square, up to 1 in., net list.	
Nuts, hex., up to 1 in., net list.	
Copper rivets and burrs, list plus	30
Burrs only list plus	50
Iron rivets and burrs.....	27 1/2
Boiler rivets, base 3/4-in. and larger	\$6.35
Structural rivets, as above	6.25
Wood screws, flat, bright.....	.75
Wood screws, O. & R., bright70
Wood screws, flat, brass.....	.42 1/2
Wood screws, O. & R., brass	40
Wood Screws, flat, bronze.	35
Wood screws, O. & R., bronze	22 1/2

MILLED PRODUCTS.

Per cent.	
Set screws	35
Sq. & Hex. Head Cap Screws	30
Rd. & Fil Head Cap Screws	10
Flat 3/4 But. Hd. Cap Screws plus	10
Fin. & Semi-fin. nuts up to 1 in., up to 1 1/2 in.	25
Fin. and semi-fin. nuts, over 1 1/2 in., up to 2 in.	30
Studs	20
Taper pins	40
Coupling bolts, plus	10
Planer head bolts, without fillet	10
Planer head bolts, with fillet	10 and 10
Planer head bolt nuts, same as finished nuts.	
Planer bolt washers	net
Hollow set screws.....	list plus 20
Collar screws	list plus 30, 10
Thumb screws	20
Thumb nuts	65
Patch bolts	add 40, 10
Cold pressed nuts to 1 1/2 in.	add \$4.50
Cold pressed nuts over 1 1/2 in.	add \$7.00

BILLETS.

Per gross ton	
Bessemer billets	\$65 00
Open-hearth billets	65 00
O.H. sheet bars	65 00
Forging billets	90 00
Wire rods	80 00
F.o.b. Pittsburgh.	

NAILS AND SPIKES.

Wire nails	5 00 4 95
Cut nails	4 70 4 70
Miscellaneous wire nails ..	60%
Pressed spikes, 5/8 diam., 100 lbs.	4 60

MISCELLANEOUS.

Solder, strictly	0 33
Solder, guaranteed	0 35
Rabbitt metals	14 to 60
Soldering coppers, lb.	0 53
Putty, 100-lb. drums	3 85
White lead, pure, cwt.....	14 25
Red dry lead, 100-lb. kegs, per cwt.	13 87
Glue, French medal, lb.	0 25
Tarred slaters' paper, roll	0 95
Gasoline, per gal., bulk.....	0 20 1/2
Benzine, per gal., bulk.....	0 29 1/2
Pure turpentine, single bbls., gal.	0 69
Linseed oil, raw, single bbls.	1 40
Linseed oil, boiled, single bbls.	1 43
Plaster of Paris, per bbl.....	2 50
Plumbers' oakum, per cwt.	8 00
Packing, square braided.....	0 27
Packing, No. 1 Italian	0 32
Packing, No. 2 Italian	0 25
Lead wool, per lb.	0 15
Pure Manila rope	0 29 1/2
Transmission rope, Manila ..	0 37 1/2
Drilling cables, Manila	0 32 1/2

POLISHED DRILL ROD.

Discount off list, Montreal and Toronto	25%
---	-----

CARBON DRILLS AND REAMERS.

Per Cent.	
S.S. drills, wire sizes up to 52	40
S.S. drills, wire sizes, No. 53 to 80	25
Standard drills to 1 1/2 in.	40
Standard drills, over 1 1/2 in.	15
3-fluted drills, plus	10
Jobbers' and letter sizes.....	40
Bit stock	40
Ratchett drills	15
S.S. drills for wood	40
Wood boring brace drills ..	25
Electricians' bits	30
Sockets	30

Sleeves	40
Taper pin reamers	20
Drills and countersinks	list plus 30
Bridge reamers	45
Centre reamers	10
Chucking reamers	10
Hand reamers	15

COLD ROLLED SHAFTING.

At mill	list plus 40%
At warehouse.....	list plus 30%

Discounts off new list. Warehouse price at Montreal and Toronto.

IRON PIPE FITTINGS.

Canadian malleable, A, add 10%; B and C, 10%; cast iron, 35%; standard bushings, 50%; beaders, 60; flanged unions, 40; malleable bushings, 50; nipples, 55; malleable lipped unions, 50.
--

SHEETS.

Montreal Toronto	
Sheets, Black, No. 28, \$6 25	\$6 75
Sheets, Black, No. 10 6 50	6 50
Canada plates, dull, 52 sheets	5 75 5 76
Canada plates, all bright	7 50 7 50
Apollo brand, 10 3/4 oz. galvanized	7 25 7 25
Queen's Head, 28 B. W.G.	7 75 7 76
Fleur-de-Lis, 28 B.W. G.	7 45 7 35
Garbal's Best, No. 28 8 25	7 50
Calhorne Crown, No. 28	8 00 6 75
Premier, No. 28 U.S.	7 75 7 45
Premier, 10 3/4 oz.	8 00 8 25

PROOF COIL CHAIN.

1/4 in.	\$9 45
5-16 in.	9 10
3/8 in.	8 35
7-16 in.	7 15
1/2 in.	6 95
3-16 in.	6 95
5/8 in.	6 80
3/4 in.	6 70
7/8 in.	6 65
1 inch	6 40

Above quotations are per cwt.

ELECTRIC WELD COIL CHAIN B.B.

1/4 in.	\$15 50
3-16 in.	11 70
1/2 in.	8 40
5-16 in.	7 40
3/8 in.	6 35
7-16 in.	6 35
1/2 in.	6 35
5/8 in.	6 35
3/4 in.	6 35

Prices per 100 lbs.

FILES AND RASPS.

Per Cent.	
Great Western, American....	60
Kearney & Foot, Arcade....	60
J. Barton Smith, Eagle....	60
McClelland, Globe	60
Whitman & Barnes	60
Black Diamond	50
Delta Files	47 1/2
Nicholson	50
Globe	57 1/2
Vulcan	57 1/2
Disston	60

COAL AND COKE.

Solvay Foundry Coke	
Connellsville Foundry Coke ..	
Yongb Steam Lump Coal ..	\$ 50
Pittsburgh Steam Lump Coal	8 50
Best Slack	9 00
Net ton f.o.b. Toronto	

BOILER TUBES.

Size.	Seamless	Lap-welded
1 in.	\$.24 00	
1 1/4 in.	30 00	
1 1/2 in.	32 00	25 00
1 3/4 in.	32 00	25 00
2 in.	35 00	26 00
2 1/2 in.	44 00	33 00
3 in.	47 00	38 00
3 1/4 in.		45 00
2 1/2 in.	50 00	48 00
4 in.	74 00	60 00

Prices per 100 feet, Montreal and Toronto.

OILS AND COMPOUNDS.

Castor oil, per lb.	27
Royalite, per gal., bulk	15
Palacine	18
Machine oil, per gal.	26 1/2
Black oil, per gal.	13
Cylinder oil, Capital	45 1/2
Cylinder oil, Acme	30 3/4
Standard cutting compound, per lb.	6 15
Lard oil, per gal.	1 45
Union thread cutting oil antiseptic	68
Acme cutting oil, antiseptic	37 1/2
Imperial quenching oil	39 1/2
Petroleum fuel oil	12 3/4

BELTING—NO. 1 OAK TANNED.

Extra heavy, single and double	30-5%
Standard	40%
Cut leather lacing, No. 1	1 50
Leather in sides	1 35

TAPES.

Chesterman Metallic, 50 ft.	\$2 00
Luffkin Metallic, C03, 50 ft.	2 00
Admiral Steel Tape, 50 ft.	2 75
Admiral Steel Tape, 100 ft.	4 45
Major Jun. Steel Tape, 50 ft.	3 50
Rival Steel Tape, 50 ft.	2 75
Rival Steel Tape, 100 ft.	4 45
Reliable Jun. Steel Tape, 50 ft.	3 50

WASTE.

White	Cents per lb.
XXX Extra	20
Peerless	20
Grand	19
Superior	19
X L C R	18
Atlas	18
X Empire	18
Ideal	17
X press	16

COLORED.

Lion	14 1/2
Standard	13
No. 1	13
Popular	11 3/4
Keen	10 1/2

WOOL PACKING.

Arrow	25
Axle	20
Anvil	15
Anchor	11

WASHED WIPERS.

Select White	12
Mixed colored	10
Dark colored	09

This list subject to trade discount for quantity.

RUBBER BELTING.

Standard	50%
Best grades	30%

ANODES.

Nickel	.50 to .54
Cobalt	1.75 to 2.00
Copper	.44 to .46
Tin	.49 to .56
Zinc	.23 to .25

Prices Per Lb.

COPPER SHEETS.

Montreal Toronto	
Bars, 1/2 to 2 in.	55 00 53 00
Plain sheets, 14 oz., 14x28 in., 14x60 in.	55 00 53 50
Copper sheet, tinned, 14x60, 14 oz.	60 00 54 25
Copper sheet, planished, 14x60 base.	64 00 60 00
Braziers', in sheets, 6x4 base	55 00 52 00

BRASS.

Brass rods, base 1/2 in to 1 in rd.	0 55
Brass sheets, 8 in. wide, 20 oz.	0 60
Brass tubing, seamless.	0 57
Copper tubing, seamless.	0 58

PLATING SUPPLIES.

Polishing wheels, felt.	2 10
Polishing wheels, bull-neck	1 35
Emery in kegs, American	06
Pumice, ground	04
Emery glue	15 to 20
Tripoli composition	04 to 06
Crocus composition	07 to 08
Emery composition	08 to 09
Rouge, silver	35 to 50
Rouge, powder	30 to 35

Prices Per Lb.

LEAD SHEETS.

Montreal Toronto	
Sheets, 3 lbs. sq. ft.	\$16 00 \$16 00

Sheets, 3 1/2 lbs. sq. ft.	16 00	16 00
Sheets, 4 to 6 lbs. sq. ft.	15 50	15 50
Cut sheets, 1/2 c per lb. extra		
Cut sheets to size, 1c per lb extra.		

PLATING CHEMICALS.

Acid, boracic	\$. 15
Acid, hydrochloric	.05
Acid, hydrofluoric	.14 1/2
Acid, nitric	.10
Acid, sulphuric	.05
Ammonia, aqua	.08
Ammonium carbonate	.15
Ammonium chloride	.11
Ammonium hydrosulphuret	.40
Ammonium sulphate	.07
Arsenic, white	.12
Copper, carbonate, anhy.	.25
Copper, sulphate	.17
Cobalt sulphate	.50
Iron perchloride	.20
Lead acetate	.16
Nickel ammonium sulphate	.12
Nickel carbonate	.35
Nickel sulphate	.15
Potassium carbonate	.75
Potassium sulphide (substituted)	.20
Silver chloride (per oz.)	.65
Silver nitrate (per oz.)	.55
Sodium bisulphite	.10
Sodium carbonate crystals	.05
Sodium cyanide, 127-130%	.41
Sodium hydrate	.04
Sodium hyposulphite, per 100 lbs.	5.00
Sodium phosphate	.14
Tin chloride	.60
Zinc chloride	.60
Zinc sulphate	.09

Prices Per Lb. Unless Otherwise Stated.

The General Market Condition and Tendency

THE industrial situation is still somewhat unsettled, due to war influence, more particularly on account of the uncertainty as to what the United States is preparing to do in regard to the protection of her rights. That the Government will take active measures is now practically assured; this has already been reflected in the steel market, as indicated by the recent sharp advance in prices. The demand for steel has been stimulated by the prospect of increased consumption and a further advance in steel prices is certain. This week, tubes, black and galvanized sheets, have advanced, while higher prices on plates, rivets and wrought pipe are looked for in the near future. Operating conditions at the mills have improved considerably, due to more favorable weather and increase in supply of raw material; production consequently will show a material improvement over each of the preceding two months. The pig-iron market continues strong and prices are still advancing. The demand, particularly for basic iron, is more insistent than at any time previously, and indications point to considerably higher prices than at present obtain. In regard to non-ferrous metals, consumers appear to be awaiting developments. The demand recently has been light, but a buying movement will likely start when the United States Government becomes more aggressive in its war policy. The only price change to note is in lead, which is slightly weaker, due to lack of interest in the market. Prices of scrap metals are generally unchanged, but firm. Steel scraps are in good demand, as is also machinery cast iron. Castor and lubricating oils have advanced, while higher prices on gasoline are likely. The machine tool market is quiet, but indications point to an improvement in demand for tools for ordinary purposes.

Montreal, Que., March 26.—The activity in industrial circles has again become settled after being disturbed over the possibility of a large railroad tie-up. The congestion that was so pronounced on all railroads is gradually being re-

lieved and transportation of material is resuming more normal conditions. The situation is still featured by the continual rise in prices of all commodities, and the apex of this movement is apparently far distant. Hopes are entertained that the

opening of navigation will relieve the situation, but indications point to insufficiency of production, rather than scarcity of transportation.

Pig Iron

The market is again featured by a general advance of approximately \$2 per ton on all grades of American pig and this change will likely be reflected in future steel prices.

Steel

Conditions throughout the steel trade have shown little improvement during the week, although the congestion on the railroads is not so pronounced and delivery of material has shown considerable improvement. The buying pressure is, however, as great as ever and everything points to a further increase in this direction, as the preparations being made by the United States government will entail much larger production by the various steel mills. What the policy of the mills will be in this connection is not definitely known, but similar action to that taken by the copper interests is anticipated, and in any case it is more than likely that preference will be given to the requirements of the home government over that of foreign interests. This may create a shortage of much needed material for the Canadian market with a corresponding increase in prices. It has been reported that recent advances have been made with a view to lessening the export demand and providing better facilities for possible home demand. A feature of the continual rise in prices has been the noticeable decline in the placing of orders for structural building material, and it is thought that this will have a beneficial

effect when the present war demand begins to fall off, as these interests will again enter the field when conditions become easier. The billet situation has again been subjected to advance, the Pittsburgh quotation on open hearth being now \$75 per ton. Sheet bars are quoted at the same figure, an advance on the week of \$10 per ton. A further advance has been made on forging billets the current quotation being \$90 per ton. A scarcity has developed in ferro-alloys and prices have generally advanced, the price quoted on ferro-manganese being now \$325 per ton, this being \$25 higher than a week ago. Plate mills are unable to accept orders for delivery this year, and some mills are booked well into the first half of 1918. Increased facilities for production have been gradually placed in operation, but little relief has as yet been experienced in the pressure on the large mills. Local dealers report a good market in plates but state that it is very difficult to get satisfactory delivery. Prices on 3-16 inch tank plates are $\frac{1}{2}$ cent higher, the quotation being now \$6.60 per hundred. Sheet mills are very active and following the advances of raw materials and sheet bars, both mills and dealers are quoting higher prices: dealers here have been forced to act in this connection and quotations this week are about $\frac{3}{4}$ cent per pound stronger than last week, the price asked being \$6.25 for No. 28 black sheets and \$6.70 for No. 10 gauge. Makers of steel shafting report a lower discount on list prices. Wire and wire products continue very brisk, the recent advance apparently having little effect upon the steady demand. Nuts and bolts, which have remained stationary for some time, are expected to advance to a higher level within the next week or two. The demand for wrought pipe is very insistent, but makers are unable to comply with the wishes of customers owing to the crowded condition of the pipe mills. Heavy premiums are freely offered for the acceptance of orders of boiler tubes, but in many cases mills are so filled up that even this consideration is no inducement. Local dealers have revised their price lists on both lap-welded and seamless tubes, the advance being approximately 15 to 20 per cent.; the changes will be found in the selected market quotations.

Metals

The metal market has experienced a little excitement over the recent action of the United States in regard to copper requirements. Whether this will spread to other metals is not yet known, but the early future will likely have some developments along these lines. Copper is firm. Tin is higher on reported sinking of tin laden vessels. Spelter is firm and slightly higher. Lead is slightly weaker abroad but stronger here. Antimony is higher in New York, but easier on the local market. Aluminum is steady and firm.

Copper.—The present market is somewhat influenced by the recent offer by large American producers, to supply the government, in event of war, with copper

at a price greatly below that prevailing on the open market. This has caused some uneasiness among consumers, who are showing a certain reluctance to place orders for far future delivery, believing that this latest move on the part of producers may ultimately result in lower prices to outside customers. While the price quoted seems low when compared to that asked from other sources, the extraordinary circumstances must be taken into consideration when summing up the situation. The requirements for the U.S. government will likely be a very small percentage of the total production of the mines and smelters, and the general situation must be governed by the outside demand and supply, which at all times is the essential factor in price quotations. With copper steady in London, the New York market has developed a weaker tendency; lake having declined $\frac{1}{2}$ cent and electro 1 cent per lb., the price quoted for each being on the basis of 35 $\frac{1}{2}$ ¢. per lb. Local conditions remain unchanged, with lake and electrolytic at 43¢. and castings at 40¢. per lb.

Tin.—The market in tin has increased in strength during the past week without any apparent reason, other than the report that a tin laden vessel has met with disaster, or that some sort of tax has been placed on tin shipments. These rumors have disturbed the even tone of the market and created a nervous situation. The position of tin meantime, is one of increasing strength, the market in London and New York having advanced. The movement in New York has resulted in a rise of 3 cents on the week, the price quoted being now 56 $\frac{1}{4}$ ¢. per lb. The local situation has followed that of other centers, and dealers here are quoting 56 $\frac{1}{2}$ ¢. on an active market.

Spelter.—Following a brief active movement earlier in the week, this metal has again settled into a quiet position, with producers sitting tight and not pressing sales. Uncertainty regarding the early future has apparently dampened the ardor of purchasers and the activity is one of immediate necessities rather than covering for future requirements. New York is $\frac{1}{8}$ cent stronger, but with an unsteady tone. Dealers here are quoting 15 $\frac{1}{2}$ ¢., an advance on the week of $\frac{1}{2}$ cent per lb.

Lead.—Conditions in the lead market are unchanged. The demand is still good, but the supply is better and railroad conditions have shown marked improvement, with the result that considerably more metal is available. A decline of $\frac{1}{8}$ cent is noted on the outside New York quotations and further weakness may develop. The market here, however, is quite strong and dealers have advanced their quotations to 12 $\frac{1}{4}$ ¢. per lb., an advance of $\frac{1}{4}$ cent on the week.

Antimony.—Owing to the scarcity of spot metal the market is retaining its strength and prices on the New York market have been advanced 2¢. per lb. Local dealers are quoting 30¢. on a steady market, this quotation being 3¢. lower than a week ago. The supply is good, but the demand has fallen off a little.

Machine Tools and Supplies

While the demand for machine tools is not as excessive as some months ago, the volume of business is still of a very satisfactory nature, and manufacturers are kept fairly busy in supplying the needs of those makers of munitions who are constantly increasing their output, or replacing tools that have depreciated in productive ability, through continual operation. Shipyard activity is gradually assuming increased proportions with the result that impetus has been given to the manufacture of a different type of machine tool than that required for the production of shells. Where quantity was the feature in shell machinery, the type of tool necessary for marine equipment will require more attention to certain features in design and capacity that have practically been eliminated during the past two years. While shell equipment has been confined largely to special tools, that required for shipyards, marine engines, etc., will be more of a general nature. Prices of machine tools and supplies are well maintained owing to the abnormal high cost of raw and semi-finished materials.

Scrap

The market is at present in a high state of excitement and developing a variable degree of uncertainty. The recent action on the part of the United States copper interests, in announcing their intention to supply the requirements of the government, in the event of war, at a figure greatly below that of the open market, has caused some uneasiness on the part of dealers, as the conflicting conditions would probably have a depressing effect upon the scrap copper market. While copper is the only metal so far considered in this connection, it is conceded that concessions may be offered in other lines of industry, which would result in a general disturbance of present conditions. With the exception of coppers, which are steady, the movement of prices is upward; machine compositions are $\frac{1}{2}$ cent higher, the quotation being 23 $\frac{1}{2}$ ¢. per lb. A similar advance has been made on brass clippings and turnings, the price asked being 19 and 16 cents respectively. The heavy demand for heavy steel scrap has had the effect of making the market stronger, this week's quotations of 16¢. showing an advance of 3¢. per lb. Steel turnings have been subjected to a similar advance, the current price of local dealers being 12¢. per lb. Old boiler plates and rails are also higher, the quotations of 15¢. and 17¢. representing respective advances of 3¢. and 2 $\frac{1}{4}$ ¢. per lb. Malleable scrap at 15¢. is 1 $\frac{3}{4}$ ¢. stronger than last week. Wrought iron pipe is quoted at 12 $\frac{1}{2}$ ¢., an advance of 2¢. per lb. Old lead is higher, heavy being quoted at 9¢. and tea lead at 7 $\frac{1}{2}$ ¢. Scrap zinc at 9¢. is $\frac{1}{2}$ cent higher than that previously quoted.

Lyons Fair.—The Fair at Lyons, France, which opened on March 19, will close on April 1. Canadian manufacturers are among the exhibitors.

Toronto, Ont., March 27. — The continued advance in prices of steel is perhaps the most important feature in industrial circles. The effect is far-reaching in that the cost of so many finished products is increased. Manufacturers using iron or steel as raw materials have for some time been obliged to raise their prices owing to the increase in production costs, while labor costs have also been going up. In addition, the shortage of steel has restricted manufacturing activity and curtailed output. The situation on the railways is somewhat improved, there being less congestion, but shipments of goods are not coming forward as freely as is desirable; this, of course, is also hampering manufacturing operations.

Steel

The anticipated increase in war demand for steel in the United States is affecting the situation in Canada. This has already been evidenced by the recent sharp advance in prices and the end of the upward movement is not in sight. The large increase in tonnage that will be required will make the congestion at the mills more acute and force prices up. War demand will take precedence over all other business and further increase the already heavy tonnage that has been sidetracked pending a return to more normal conditions and prices. Thus, what might be called reserve or latent tonnage will be an important factor in the steel trade when the time for readjustment comes after the war. It will tend to steady the market when the more urgent war demand falls off. The enormous demand for ship plates and shapes continues to be the chief feature in the market. It is understood that the Imperial Munitions Board contemplates an expenditure of approximately \$25,000,000 on steel ships, the construction of which will be put in hand as rapidly as possible under the circumstances. The rapidity of construction will depend upon the supply of steel obtainable and available capacity of shipbuilding plants to undertake the work. The U.S. Steel Corporation has recently accepted an order for 5,000 tons of ship plates and 2,000 tons of angles for quick delivery to a Canadian shipyard. The quotations given for plates in our selected market quotations are warehouse prices and an advance is expected shortly. The mills have withdrawn prices on ship plates owing to their sold-up condition and difficulty of promising deliveries. Boiler tubes both seamless and lapweld have advanced about 10 per cent., very few makers of iron or steel tubes quoting for delivery this year. Higher prices on wrought pipe, boiler rivets, bolts and nuts are expected in the near future.

Prices of black and galvanized sheets are higher following the recent advance in the primary market. Black No. 28 are quoted at \$6.75, and No. 10, \$6.50. Premier galvanized No 28 are now \$7.95, and 10¾ ozs., \$8.25 per 100 pounds. As might be expected the market is very strong and a further advance may be looked for. The demand for black sheets is very heavy and deliveries are getting more backward

all the time, while output is restricted on account of the scarcity of sheet bars.

The steel market in the United States is very strong with the volume of business steadily increasing. The annual report of the U.S. Steel Corporation recently published reveals the unprecedented conditions now prevailing in the trade in America. Export demand shows little indication of diminishing while domestic demand is more insistent and will be augmented considerably by Government requirements. Prices on all steel products are very firm and further advances are certain.

Pig Iron

The market continues very strong with urgent demand for all deliveries. Prices continue to advance in the U.S., affecting practically all grades of pig iron. At Buffalo, lower grade foundry irons are being quoted at \$39, furnace, and higher silicon grade, \$40 furnace. Domestic pig iron is still quoted at \$43, but an advance may be looked for shortly.

Scrap

The scrap market continues firm and prices generally are being maintained at levels quoted last week. Heavy melting steel continues firm and is in good de-

CANADIAN GOVERNMENT PURCHASING COMMISSION

The following gentlemen constitute the Commission appointed to make all purchases under the Dominion \$100,000,000 war appropriation:—George F. Galt, Winnipeg; Hornidas Laporte, Montreal; A. E. Kemp, Toronto. Thomas Hilliard is secretary, and the Commission headquarters are at Ottawa.

mand, while low phosphorous scrap is also active. No. 1 machinery cast iron is in good demand at unchanged prices. Prices of copper and other non-ferrous scrap are easier with fair demand. Business locally continues good, but the outlook as to the future for scrap prices is somewhat uncertain. Indications point to higher rather than lower prices on all steel and cast iron scrap, but on copper and brass, etc., scrap, the outlook is unsettled.

Machine Tools

There have been no developments of importance during the week in the machine tool market. The character of business appears to be gradually changing from quotations plants to what may be termed ordinary business. Some interesting orders have been placed recently with local machinery houses for equipment for the new Camp Borden aviation plant shops, and other business of similar nature is pending.

Supplies

The expected advance in lubricating oils is in effect, machine oil being now quoted at 26c. and black oil 13c. per gallon in barrel lots. Castor oil is also up,

the new price being 27c. per pound, while standard cutting compound is a shade higher at 6.15c. per pound. The low range for babbitt metals is now 14c. as against 13c. formerly. The new discount on miscellaneous wire nails is 60 per cent. as compared with 65 per cent. formerly. Turpentine has declined 2c. and is 69c. per gallon, but linseed oil is unchanged.

Metals

The situation in the metal markets shows little change since last week except perhaps a weaker tendency in prices due to lack of demand. This, however, has not as yet had any effect on prices with the single exception of lead, which has declined slightly. The purchase of copper by the United States Government at a price rather better than 16½c. per pound has not as yet affected the market, and may not in the future, as the amount involved is not very important when compared with the annual production of this metal. Business locally continues brisk and the outlook for the trade is favorable.

Copper.—The most important feature in the market this week has been the purchase of 45,500,000 pounds by the U.S. Government at a shade better than 16½c. a pound. Although this is about 20c. lower than the market, prices have not as yet declined, but the tone is a little easier. The amount of copper involved, however, is not very important compared with the annual production, although, further transactions on the same basis might probably materially affect the market. Local quotations are unchanged and nominal at 40c. for lake and electrolytic, and 39c. for castings copper.

Tin.—Considerable strength has developed in the market as a result of higher prices in London. The demand, however, has been light, and New York prices are still nominal. Local prices unchanged at 56c. per pound.

Spelter.—The market is dull with galvanizers, and brass mills are practically out of the market. Local quotations are unchanged at 14c. per pound.

Lead. Prices are a shade lower, the market having an easier tendency, due principally to falling off in demand. The "Trust" price of 9c. New York is still held with independents ½c. to ¾c. higher. Local quotations are now 12½c. per pound.

Antimony. There continues to be a scarcity of antimony with very little metal offering. The market is quiet with quotations nominal and unchanged at 35c. per pound.

Aluminum. The market is strong, but demand is light. Quotations are unchanged at 68c. per pound.

Sydney, N.S., March 23.—The production of the Dominion Coal Co. Cape Breton collieries for March will reach 340,000 tons, which is the largest monthly tonnage for a long time past. The increase is to some extent due to the fact that March has 27 working days, also to the fact that men are working more steadily, and that the drain from recruiting has been stayed. The decline in production is shown by the figures

for the financial year of the Dominion Coal Co., which ends March 31, these being, for the Cape Breton and Springhill Mines combined, less than the figures of the previous fiscal year by exactly one million tons.

One of the Springhill slopes has for some time been closed by an underground fire. Satisfactory progress is being made in the recovery of the mine, but it is not expected that the raising of coal will be undertaken until delivery is obtained from England of a turbo-compressor to provide compressed air for the underground pumps formerly operated by steam. The conveyance of steam pipes for long distances underground is an objectionable and uneconomical practice. The delivery of the necessary machinery has been delayed by the pressure of war work in England.

Labor matters at the collieries are a little unsettled, and there is a recrudescence of the United Mine Worker agitation that brought about the strikes of 1909. An application has been made to the Minister of Labor for a Board of Conciliation to adjudicate upon a request made by the U. M. W. for a 25 per cent. advance in wages. As the question of wages has for some time been the subject of negotiations between the management of the Dominion Coal Co. and the Provincial Workmen's Association, it is not thought the Minister will grant a board until the negotiations have been concluded. The American Federation of Labor has attempted the organization of the workmen of the collieries and munition works near New Glasgow, and also at Sydney Mines, but it is very unlikely any of the companies will hold negotiations with this body or any other body having its headquarters in the United States. International labor unions are not viewed with favor in Nova Scotia, where, seeing that local labor unions have already had a long and successful history, it is considered foreign organizations are superfluous and mischievous.

At the steel plants there has been some indication of a lessening in the volume of shell orders, which seems to point to increased ability of the Old Country plants to take care of requirements. An interesting happening of the week is the decision of the Dominion Steel directors to declare a four per cent. dividend, payable quarterly. This is the first dividend paid by the Steel Corporation since the initial dividend paid at the time of the amalgamation of the Steel & Coal Companies in 1910. It is expected that excavation work will shortly be commenced on the site of new coke ovens and by-products plant for the Dominion Steel Co. This installation will probably necessitate a new coal washer. More definite particulars will be available shortly. The opening of navigation looks like being later than usual. A large accumulation of shipments awaits the resumption of sailings from Sydney, as rail carriage has been limited during the past three months by congested roads and every conceivable kind of embargo.

Enlarged Canadian Trade Intelligence Service

Under the arrangement made by the Minister of Trade and Commerce with Sir Edward Grey in July, 1912, the Department of Trade and Commerce, Ottawa, is able to present the following list of the more important British Consulates whose officers have been instructed by the Foreign Office to answer inquiries from and give information to Canadians who wish to consult them in reference to trade matters.

BRAZIL—Bahia, British Consul. Rio de Janeiro, British Consul General.	NETHERLANDS—Amsterdam, British Consul.
CHILE — Valparaiso, British Consul General.	PANAMA—Colon, British Consul. Panama, British Vice-Consul.
COLOMBIA — Bogota, British Consul General.	PERU—Lima, British Vice-Consul.
ECUADOR—Quito, British Consul General. Guayaquil, British Consul.	PORTUGAL—Lisbon, British Consul.
EGYPT — Alexandria, British Consul General.	RUSSIA—Moscow, British Consul General. Petrograd, British Consul. Vladivostok, British Consul. Odessa, British Consul General.
FRANCE—Havre, British Consul General. Marseilles, British Consul General.	SPAIN—Barcelona, British Consul General. Madrid, British Consul.
INDIA—Calcutta, Director General of Commercial Intelligence.	SWEDEN—Stockholm, British Consul.
ITALY—Genoa, British Consul General. Milan, British Consul.	SWITZERLAND—Geneva, British Consul.
MEXICO—Mexico, British Consul General.	URUGUAY—Monte Video, British Vice-Consul.
	VENEZUELA — Caracas, British Vice-Consul.

Canadian Commercial Intelligence Service

The Department of Trade and Commerce invites correspondence from Canadian exporters or importers upon all trade matters. Canadian Trade Commissioners and Commercial Agents should be kept supplied with catalogues, price lists, discount rates, etc., and the names and addresses of trade representatives by Canadian exporters. Catalogues should state whether prices are at factory point, f.o.b. at port of shipment, or, which is preferable, c.i.f. at foreign port.

CANADIAN TRADE COMMISSIONERS.

ARGENTINE REPUBLIC—H. R. Poussette, Reconquista, No. 46, Buenos Aires. Cable address, Canadian.
AUSTRALIA—D. H. Ross, Stock Exchange Building, Melbourne. Cable address, Canadian.
BRITISH WEST INDIES—E. H. S. Flood, Bridgetown, Barbadoes, agent also for the Bermudas and British Guiana. Cable address, Canadian.
CHINA—J. W. Ross, 13 Nanking Road, Shanghai. Cable address, Cancom.
CUBA—Acting Trade Commissioner, Lonja del Comercio, Apartado 1290, Havana. Cable address, Cantracom.
FRANCE—Phillipe Roy, Commissioner General, 17 and 19 Boulevard des Capucines, Paris. Cable address, Stadacona.
JAPAN—G. B. Johnson, P. O. Box 109, Yokohama. Cable address, Canadian.
HOLLAND—Acting Trade Commissioner, Zuidblaak, 26, Rotterdam. Cable address, Waterrmill.
RUSSIA—C. F. Just, Canadian Government Commercial Agent, Alexandriyskaya, Ploshch 9, Petrograd. L. D. Wilgress, Canadian Government Commercial Agent, Bukhgalza Ulitza No. 4, Omsk, Siberia.
NEWFOUNDLAND—W. B. Nicholson, Bank of Montreal Building, Water Street, St. John's. Cable address, Canadian.
NEW ZEALAND—W. A. Beddoe, Union Buildings, Customs Street, Auckland. Cable address, Canadian.
SOUTH AFRICA—W. J. Egan, Norwich Union Buildings, Cape Town. Cable address, Cantracom.
UNITED KINGDOM—Harrison Watson, 73 Basinghall Street, London, E.C., England. Cable address, Sleighbing, London. N. D. Johnston, Sun Building, Clare Street, Bristol. Cable address, Canadian. J. E. Ray, Central House, Birmingham. Cable address, Canadian. J. Forsyth Smith, 27-28 Pearl Building, East Paradise, Leeds. Cable address, Canadian. F. A. C. Bekerdiike, Canada Chambers, 36 Spring Gardens, Manchester. Cable address, Cantracom. J. T. Lithgow, 87 Union Street, Glasgow, Scotland. Cable address, Cantracom.

SPECIAL TRADE COMMISSIONER—LUMBER

H. R. McMillan, visiting Europe, Africa, Australasia and the Orient.

CANADIAN COMMERCIAL AGENTS

AUSTRALIA—B. Millin, Exchange Building, Sydney, N.S.W.
BRITISH WEST INDIES—Edgar Tripp, Port of Spain, Trinidad. Cable address, Canadian. R. H. Curry, Nassau, Bahamas.
NORWAY AND DENMARK—C. E. Sontum Grubbegeed No. 4, Christiania, Norway. Cable address, Sontums.

CANADIAN HIGH COMMISSIONER'S OFFICE

UNITED KINGDOM—W. L. Griffith, Secretary, 17 Victoria Street, London, S.W., England. Cable address, Dominion, London.

Gould & Eberhardt High-Duty Shapers

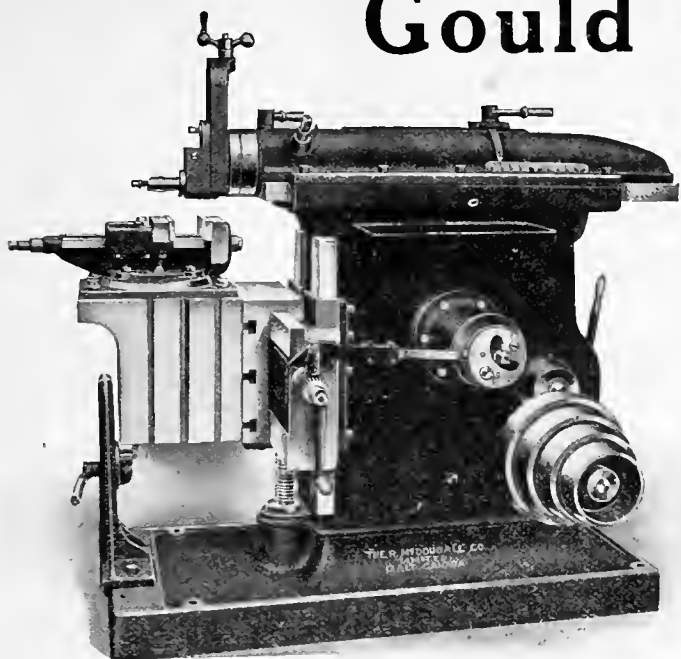

2-24" in stock
6-20" in two weeks

*Get our new stock list of
new and used machinery.*

The A. R. Williams Machinery Company, Limited

St. John, N.B.
Winnipeg, Vancouver

"If It's Machinery Write Williams"

64 West Front St.,
TORONTO



HAVE YOU GIVEN THE GEOMETRIC O.K. TO YOUR SCREW THREADS

A Consulting Engineer writes us that he always recommends Geometric Thread-Cutting Tools. The reason is not hard to know. It is for this same reason that Geometric Screw-Cutting Tools are sought for every make of Screw Machine.

We are always glad to have thread-cutting propositions submitted to us. There is no charge for our recommendations. Send along your specifications, and our experts will recommend tools for your consideration. May we have your address for our mailing list, so that we can send you our publication, THREADS, each month? That will help us get acquainted. It is free.

THE GEOMETRIC TOOL CO., New Haven Conn., U.S.A.

Williams & Wilson, Ltd., Montreal

CANADIAN AGENTS

The A. R. Williams Machinery Co., Ltd., Toronto Winnipeg, St. John, N.B.

If any advertisement interests you, tear it out now and place with letters to be answered.

INDUSTRIAL ^A_N^D CONSTRUCTION NEWS

Establishment or Enlargement of Factories, Mills, Power Plants, Etc.; Construction of Railways, Bridges, Etc.; Municipal Undertakings; Mining News

ENGINEERING

Guelph, Ont.—The Flexible Conduit Co. are building a factory for making nitrogen lamps. Mr. Wheeler is the manager.

Prince Rupert, B.C.—The City Council are considering the question of erecting a cold storage plant to assist in the development of the fishing industry.

Toronto, Ont.—The Polson Iron Works have been granted a permit to erect an addition to their plant. The building will be a 2-storey structure 12 x 30 ft.

Guelph, Ont.—The International Malleable Iron Co. will build an extension to the main foundry building 216 feet long by 100 feet wide. Contracts have been let.

New Glasgow, N.S.—Fire on March 14 did considerable damage to the plant and boiler house of the Munro Wire Works. The loss is partly covered by insurance.

Porcupine, Ont.—The Northern Canada Power Co. is increasing the capacity of its plant from 8,000 h.p. to 13,000 h.p. One unit of 2,500 h.p. is now in the course of construction and the second unit will be installed this summer.

Matheson, Ont.—Machinery for the 50-ton mill at the Croesns is expected to arrive shortly and will be rushed to the property at once before the spring break-up. Lumber has already arrived, and, it is understood, everything is being put in shape for the reception of the machinery on its arrival there.

Port Arthur, Ont.—Despite its failure to get the Black Sturgeon pulp limit, the Port Arthur Pulp & Paper Co., composed of Toronto capitalists, is going ahead with its plant here. Offices have been opened in the city, and it is announced construction will start the first week in April. The pulp supply will be procured from independent operators and farmers. A. G. McCormack has resigned as Secretary of the Board of Trade to join the Port Arthur Pulp & Paper Co.

Victoria, B.C.—C. Silverman announces that he has purchased the machinery from the B. C. Equipment Co., of Vancouver, for installation at a mill at Sidney Inlet for the flotation process of concentrating ores, in connection with the mines there, which he has been developing for some months past. Mr. Silverman took over the old Dewdney property on Sidney Inlet. It is expected that the mill will be ready for use by June 15, and when complete it will cost in the neighborhood of \$50,000 and will be capable of handling 250 tons of ore daily.

MUNICIPAL

Gleichen, Alta.—The town may purchase the local electric light plant owned by F. C. Vigor for \$6,000.

Radville, Sask.—The Town Council are considering the erection of a \$12,000 electric light plant.

London, Ont.—The City Council contemplates the installation of steam auxiliary equipment in connection with incinerator, to cost \$25,000.

Sault Ste. Marie, Ont.—The Town Council have retained R. O. Wynne-Roberts consulting engineer of Toronto, to report on a 5-million gallon per day water supply.

Sherbrooke, Que.—The City Council propose purchasing the Two-Mile Falls Power near Weedon for \$375,000. The question will be submitted to the ratepayers for approval.

Wolseley, Sask.—A by-law will be voted on by the ratepayers on April 7 to authorize the purchase of a gas engine, dynamo and building for a municipal power plant at \$9,000. A. B. Hill is sec.-treasurer.

Trenton, Ont.—The Town Council's application to grant aid to the British Chemical Co., by granting exemption from all taxes, except school taxes, to pay \$10,000 towards the purchase of the site for works of the company, has been granted.

Rosthern, Sask.—The Town Council has decided to proceed at once with the matter of establishing an electric light system in the town, and the firm of Murphy & Underwood, of Saskatoon, have been engaged to make preliminary estimates of the cost, the size of a plant required, location, etc.

Windsor, Ont.—Little interest was taken in the voting on Monday but all the by-laws carried. That to sell land to Peter Osterhout, a Windsor builder, for a factory site, carried by a vote of 54 to 14. A by-law giving similar privileges to the Canadian Oil Co. succeeded by 58 to 10, while the Max Goldman and Samuel Harris by-law was favored by 51 to 17.

Charlottetown, P.E.I.—The Commissioners of Sewers and Water Supply asked the Council that they apply to the Legislature for power to issue additional debentures, amounting in all to \$15,000, to cover the cost of completing the installation of machinery, driving wells, extending the pipe line to new districts and increasing the pumping units in connection with the sewage system. The request was granted.

Toronto, Ont.—Estimates of the Street Cleaning Department for expenditures during 1917 call for \$1,027,125.

Commissioner Wilson asks \$37,500 for plant and shop, \$18,000 for the Straehan crematory and \$34,450 for the Don destructor. The sum of \$12,000 has been placed in the estimates for purchase of motor trucks for pick-up work and \$12,000 more for motor trucks for ash removal from the Don destructor.

Toronto, Ont.—Expenditures of \$3,552,976 by the Civic Works Department during 1917 are provided for in the estimates of Commissioner Harris. Under capital expenditure, Commissioner Harris is asking for \$149,370 for reconstruction of the bridge on South Glen Road, and \$63,200 for reconstruction of bridge on Spadina Road. There is an item of \$25,000 for an additional pump and motor and connection to mains at the Riverdale pumping station. For main extensions the following sums have been placed in the estimates: High pressure fire system extension, \$600,000; extension of distribution system in district east of Don River and north of Gerrard Street, \$375,000; two 36-inch water mains under tracks of C. P. R. and G. T. R., from main pumping station to Front Street, \$95,000.

GENERAL

Brampton, Ont.—The Gummed Paper Co., proposes to erect a two-storey addition to its factory and to install new machinery.

Ridgetown, Ont.—Hunt Bros., have purchased a site for their new six-storey mill, and work will be commenced at once on the \$150,000 plant.

Aylmer, Ont.—Fire on March 21 destroyed the flour and feed warehouse of A. W. Pierce. The loss is estimated at \$25,000, covered by insurance.

Chatham, Ont.—The property of the Blonde Lumber Co., including the large three-storey brick mill and considerable equipment, has been purchased by Archie Park for \$13,000.

Montreal, Que.—A fire which broke out on March 20, in the basement of the Ingersoll Packing Co., St. Paul Street, spread to the adjoining premises occupied by the Continental Bag Co., Vaillancourt & Co., Geo. McGarry, A. A. Ayer & Co., and Z. Limoges, produce dealers. The loss is estimated at \$200,000.

Peterboro, Ont.—The Quaker Oats Co., whose plant was destroyed by fire last December, have decided to rebuild in Peterboro, and on the original site, in consequence of which the ratepayers will vote on a by-law to build a high-level bridge across the Otonabee River, near the new plant, which will permit Trent Canal traffic to the mills. The Government will assist in building the bridge.

W. A. Fraser has come back

YOU remember W. A. Fraser, the brilliant Canadian author of "Mooswa," "Thoroughbreds," "Blood

Lilies," and other good stories of India and Canada? Latterly Mr. Fraser's literary activity has been in repose, but now he has arranged to provide **MacLean's Magazine** with a brand new series of short stories, the first of which, "A WANDERING MUMMY," is a fine tale of the Canadian West, with an East Indian strand woven into it. It appears in the April **MacLean's**.

Canada is producing some very good short-story writers—new ones that is. We have Stringer, McFarlane, Sullivan, Leacock, Miss Laut, Roberts, Seton, Parker, O'Higgins, Patullo, L. M. Montgomery, et al, of international fame; and a new lot breaking into the greater light. One of these newer writers is

Hopkins Moorhouse, who is "coming strong." Mr. Moorhouse is a Manitoban, and to the April **MACLEAN'S** he contributes *The Centre of Gravity*, "corking good stuff," to use the language of the Editor. This is the first of a series of stories featuring Andy Doolin, a "character," keeper of a saloon. These stories are of the boom days in British Columbia's gold mining history, days when Jim Crotty, Dutch McGee, and The Parson, desperadoes all, made life a catchy thing and stirring.

Mary Gaunt, a new contributor to **MACLEAN'S**, has in the April Number a short story, *At the Arrow Forks*, a tale of the Yukon. Miss Gaunt is a British woman who knows her Canada well—from sojourn, visit and study.

James B. Hendryx is a well-known writer whose 90,000-word serial story begins in the April **MACLEAN'S**, *The Gun-Brand*, is of the Peace River Country, and is of gun-runners, Indians, whiskey, a Hudson's Bay Company post, voyageurs, and a dream of a girl.

Agnes C. Laut, H. F. Gadsby and W. A. Craick are contributors to the April **MACLEAN'S**. Each contributes a special article of great and immediate interest. For example, **MISS AGNES C. LAUT**, a wonderful woman, writes of the war situation as found in the United States, and in its relation to Canada. **H. F. GADSBY** writes of the Canadian Senate—a judicial article on a subject of ever-growing political interest. **W. A. CRAICK'S** contribution is *Motor Roads of Canada*, and is concerned with motor-touring in Canada. His article is well illustrated.

Now, these are just a part of the contents of

MACLEAN'S

THEY suffice, however, to give you a good idea of the distinctive Canadian character and appeal of **MACLEAN'S**, and to let you and others see that in **MACLEAN'S** one gets his money's worth and more, whether it be mere entertainment that is sought, or something informative, stimulating and timely concerning Canada life, interests, thought and politics.

for April

*At All News-
Agents*

Fifteen Cents

Long Wear and Rapid Cutting are Features of Delta Files

These features mean a saving in time and reduced file expenses.

The extra durability of Delta Files means a surprising curtailment in file expenses when the accumulating results of a year's use of these files in your shop are considered.

DELTA FILES

cut faster and outlive any other file made, because they retain their cutting edges longer.

There is a Delta File for every purpose, and a Delta File means a time-saving on every man that uses one. Made absolutely of crucible steel and the only files made in lengths from 3 to 24 inches long.

We will send you a sample file to enable you to prove these features to your own satisfaction. Ask for your sample.



DELTA FILE WORKS

PHILADELPHIA, PA., U.S.A.

CANADIAN AGENTS:

H. S. Howland, Sons & Co., Toronto;

Starke, Seybold, Montreal;

Wm. Stairs, See & Morrow, Halifax;

Merrick-Anderson Co., Winnipeg

All Leading Jobbers.

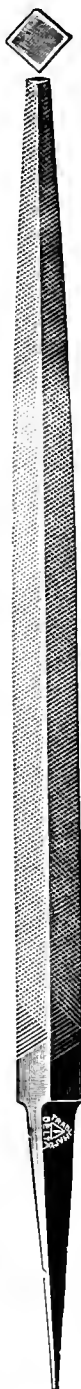

TRADE GOSSIP

Samuel Osborn (Canada), Ltd., of Montreal, has been granted a license to carry on business in Ontario with a sum of not less than \$40,000.

The Cincinnati Iron & Steel Co., Cincinnati, Ohio, are distributing a useful advertising novelty in the form of a circular metallic thermometer featuring the "Ciseo" line of machine tools.

Kitchener, Ont.—Owing to the increase in the price of coal and gas oil the Light Commission has announced that the price of gas will be advanced until further notice from \$1 to \$1.15 per thousand, and that a minimum rate of 50c per month has been fixed.

Rate on U.S. Ships Higher.—It is reported from Washington, D.C., that a flat rate of three per cent. for insurance on vessels leaving American ports for ports of belligerent nations has been fixed by the government war risk insurance bureau. The highest rate has been 2 per cent.

Canal Engines for France.—Thirteen locomotives which were used on the construction of the new Welland ship canal have been secured by the Dominion Government for shipment to France to be used in war purposes. They are not needed here now on account of the closing down of the work.

Dominion Government Order Locomotives.—Fifty new locomotives have been ordered by the Government for the Canadian Government Railways. They will be constructed by the Canadian Locomotive Works at Kingston. The contract, which is intended to increase the motive power of the Government railways, was signed on March 21.

Shipyard for Canada.—It is reported that efforts are being made to secure the location in Canada of one of the British shipbuilding companies. This would involve the establishment of a yard on the Atlantic coast. It is understood that this is one of the subjects to be taken up by Sir Robert Borden and it is being furthered by the Imperial Munitions Board.

The Turbine Equipment Co., Toronto, have been awarded a contract by the Union Carbide Co., of Niagara Falls, N.Y.; and Welland, Ont., for three De Laval single stage, double suction pumps, of 3-million, 2-million and 1-million gals. daily capacity respectively, to be motor driven.

They have also received an order from the Canadian Copper Co., Copper Cliff, Ont., for two single stage, double suction De Laval pumps. Each having a capacity of 3-million gals. daily.

Represents Russian Industry.—Gaston, Williams & Wigmore, Inc., have been appointed the commercial representative in the United States for the council of the All Metal Working Industries of Russia, which represents a union of the metal industries in Russia. The purchases to be made across the line will consist of machinery and equipment for the factories of the various

members of the council and other materials.

The Turbine Equipment Co., Toronto, have been awarded a contract by The Imperial Oil Co., Church St., Toronto, to supply for their new plant at Dartmouth, N.S., 13-De Laval single stage, double suction pumps, ranging in size from 1500 gals. to 350 gals. a minute. The Imperial Oil Co., have also placed another order for two additional single stage, double suction, high lift De Laval pumps, each to be direct connected to 150 h.p. motors.

The Turbine Equipment Co., Toronto, have received a contract amounting to \$19,000 to supply and install, 8-De Laval single stage, double suction centrifugal pumps, for the new filtration plant for the town of St. Hyacinthe. One will be 5 million Imperial gals. daily unit, another 4½ million gals. daily, and there will be 6 having capacity of 2½ million Imperial gals. daily. All these pumps will be connected direct to Canadian Westinghouse motors. They will also supply 40 h.p. motor driven roots blower, complete switch-board etc.

Marine Engineers Meet.—The National Association of Marine Engineers held their closing banquet, following a series of successful Winter meetings, at the Sons of England Hall, Toronto, on March 22. At the previous meetings business managers for the Great Lakes district had been appointed and the presence last evening of the president and two members of the Great Lakes Council, and two members of the Grand Council, made for a large turnout. Three new members were initiated. The almost general adoption of the new wage scale by shipowners was the source of much gratification, and speeches were all of a most optimistic nature.

Joint Technical Societies Meeting.—The annual meeting of the Joint Committee of Technical Societies will be held in the Chemistry and Mining Building, Toronto University, Toronto, the evening of March 30th, and will be addressed by John Murphy, Chief Electric Engineer of the Department of Railways and Canals; Mr. Matheson, late of Colorado, but now Chief Engineer of the British American Nickel Corporation, and others. All engineers, whether or not they are members of any society, will be privileged to attend this meeting. Correspondence should be sent direct to the secretary of the Joint Committee of Technical Organizations, Ontario branch, Excelsior Life Building, Toronto.

U.S. Government Purchase Copper.—Advices from Washington, D.C., state that the principal American copper producers have agreed to furnish the Government copper needed for the army and navy during the coming year at 16 and a fraction cents a pound, about one-half of the current market price. Forty-five million pounds is the amount to be delivered. This solves one of the important problems in connection with large orders for munitions soon to be placed, and is the first big concession in

response to the appeals to the patriotism of the country's industries since the navy's agreements with the shipbuilders and steel makers for profit cutting. The action of the copper producers was announced by the Council of National Defence.

Government Will Take Over Ross Rifle Factory.—The expropriation by the Government of the Ross Rifle factory at Quebec, to be operated on the lines of the Dominion Arsenal, will take place this week, according to present plans. Proceedings will be taken under the Expropriation Act, which, through the War Measures Act, has been extended in its scope. This action follows that of the Government in cancelling the order for the last hundred thousand of Ross rifles, resulting in the closing down yesterday of the factory. The manufacture of the Lee-Enfield rifle by the Government at the Ross factory is to be arranged for as soon as the sealed patterns and specifications arrive, and the machinery is adapted to the new rifle.

WOODWORKING

Danville, Que.—The Danville Chair & Specialty Co., will not rebuild their factory which was destroyed by fire recently. A new company may be formed to deal with the situation.

Belleville, Ont.—The plant of the Pearce Co., in Marmora Village, was totally destroyed by fire on March 22. The company was engaged in the manufacture of lumber, shingles and lath, and had a very extensive and well-equipped plant. The total loss is estimated at \$25,000, with no insurance. F. S. Pearce is president of the company.

RAILWAYS—BRIDGES

Brantford, Ont.—Negotiations are still proceeding between the Lake Erie & Northern Railway and the Grand Trunk for the use by the former of the latter's entrance into Port Dover. In the meantime the formal opening of the line has been postponed.

Fort Frances, Ont.—The Fort Frances and English River Railway Co. will make application during the present session of the Legislature to incorporate a company with power to construct and operate a railroad from Fort Frances to English River via Kenora.

Victoria, B.C.—The Esquimalt & Nanaimo Railway is practically ready to start work on the construction of a new swing bridge over the harbor, to replace the present old structure, which the company declares is far too small and too weak to handle the freight and passenger traffic into Victoria.

TENDERS

Toronto, Ont.—Tenders will be received for a building until April 9, addressed to the Toronto Harbor Commissioners, 50 Bay Street, Toronto, Ont.

All information may be obtained by applying to the Architects, Chapman

WM. MUIR & CO., LIMITED
 Manchester, England.
 Machine Tool Makers.
 Specialties: Patent Puncher Slotting Machines, Milling Machines, Boring Machines.
 Agents: Messrs. Peacock Bros., 68 Beaver Hall Hill, Montreal.
 Send for catalogue.

JOHN STIRK & SONS, Limited
 HALIFAX, ENG.
MACHINE TOOLS
 Agents—The A. R. Williams Mcy. Co., Ltd.
 Toronto, Winnipeg, Vancouver, St. John, N.B.

BERTRAMS LIMITED
 Engineers
 Sciennes, EDINBURGH
 PAPER MILL MACHINERY
 and
MACHINE TOOLS for IRON WORKERS
 Catalogues offered to Purchasers.

WIRE SPRINGS
 OF ALL KINDS
 Machine Springs, Valve Springs, Automobile Cushion Springs, etc., of a quality that defies competition. Tell us your requirements. Send sample or specification for price.
JAMES STEELE, LIMITED
 GUELPH, ONTARIO

Quality is Highest—Not the Price
Dickow's Guaranteed 10-Inch Universal Index Centers
 You save from \$50 to \$125 on first cost, and many times that because of their simple construction and great ease of operation. They embody the maximum of accuracy, simplicity and durability.

 Get the Original—Beware of Imitators
 Sold by all dealers. Write to-day for particulars
 Fred. C. Dickow, 35 So. Desplaines St., Chicago, Ill., U.S.A.

Oil Tempered Steel Springs
 —for every purpose and the best for each use.
 Special styles of all kind, to order.
THE CLEVELAND WIRE SPRING COMPANY
 Cleveland, Ohio U.S.A.



BOLTS
 Our large stock of Machine Bolts, Rivets and Washers assures quickly filled orders and prompt shipment. One quality only—The Best.
 Send a trial order.
LONDON BOLT & NUT WORKS
 London Ontario

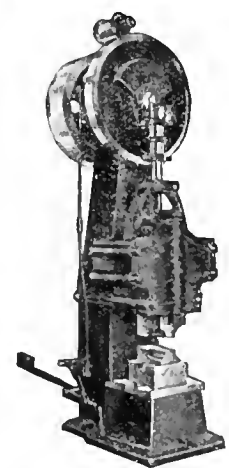

Special Machinery
 MADE TO ORDER
 Mill Machinery, Engine Work
 Grey Iron and Brass Castings
 TRY US FOR GENERAL REPAIRS
ALEXANDER FLECK, LIMITED
 (Vulcan Iron Works) OTTAWA, ONT.

The "Dupont" PATENT Power Hammer

 The strength, durability, economy of power and simplicity of adjustment of the Dupont Power Hammer make it a decidedly superior tool.
 Made carefully from carefully selected, high-class materials.
 Positively Guaranteed
 Seven sizes.
 With rams from 35 to 300 lbs.
 Write for full details.
THE PLESSISVILLE FOUNDRY
 Plessisville, Que.
 Ontario and Western Agents:
 The General Supply Co. of Canada Ltd.
 Ottawa Toronto Winnipeg

PATENT ATTORNEYS

BABCOCK & SONS

ESTAB. 1872

PATENTS—TRADE MARK—DESIGNS
IN ALL COUNTRIES

Book "Patent Protection"—free. Master of Patent Laws. Formerly Patent Office Examiner.

99 St. James St., - Montreal, Que.
Branches: Ottawa, Washington.

RESEARCH BUREAU

REPORTS BY EXPERTS ON SCIENTIFIC, TECHNICAL AND INDUSTRIAL DEVELOPMENT.

SPECIAL RESEARCHES ARRANGED.

PATENTS, TRADE MARKS, ETC.

HAMBURY A. BUDDEN

CABLE ADDRESS

712 DRUMMOND BLDG., MONTREAL

"BREVET"

PATENTS

Fetherstonhaugh & Co.
Patent Solicitors. Head Office,
Royal Bank Bldg., Toronto.
Ottawa Office, 5 Elgin St.
Send for our Plain Practical
Pointers. Copy of National
Progress, in which our patents
are advertised, mailed free.

PATENTS PROMPTLY SECURED

In all countries. Ask for our Investor's Adviser, which will be sent free.

MARION & MARION, 364 University St.

Merchants Bank Building, corner
St. Catherine St., MONTREAL, Phone Up. 6474
and Washington, D.C., U.S.A.

SPECIAL MACHINERY

GAUGES, FIXTURES, DIES
AND
PRECISION TOOLS

WE HAVE THE
MOST MODERN
EQUIPMENT
TO HANDLE
ANY CLASS OF WORK

CANADIAN DISTRIBUTORS FOR THE

ALBANY PATENT ROTARY
PUMP

Albany Pump Co.

16 Pearl St., TORONTO, Canada
Phone Ad. 2511 A. W. Bennet, Manager

and McGillin, 95 King Street East, Toronto.

Terrebonne, Que.—The Town Council are calling tenders for a shoe factory. The plans and specifications of this building can be seen in the office of Dupont Roy & Beaudoin Engineers, 225 St. James Street, Montreal.

Montreal South Que.—Tenders will be called sometime in April, for a 30-h.p. motor-driven turbine pump and a 150-h.p. gasoline engine-driven turbine pump for fire purposes, etc. E. Drinkwater, St. Lambert, Que., is the engineer.

Grandview, Man.—Tenders will be received until March 28, for two steel bridges. Plans, specifications and tender forms can be obtained at the office of the Highway Commissioner, Winnipeg, or from W. Dickie the Secretary-Treasurer at Grandview.

London, Ont.—Tenders will be received by the Board of Control until April 5, for general supplies, including hardware, harness, lubricating oil, rubber supplies, etc., and iron castings. Specifications can be obtained at the office of the City Engineer, H. A. Brazier.

Cartwright, Man.—Tenders will be received by the Rural Municipality of Roblin up to April 5 for abutments and steel work for four bridges. Plans, specifications and tender forms may be seen at office of Highway Commissioner, Winnipeg, or at the office of Secretary-Treasurer, Cartwright, Man.

Toronto, Ont.—Tenders will be received up to April 2, addressed to the chairman of Toronto Harbor Commissioners, 50 Bay street, Toronto, for the construction of harbor head walls. All information may be obtained by applying to the above address. E. L. Cousins, chief engineer and manager.

St. Felix de Valois, Que.—Tenders will be received until March 31, at the office of the corporation of the parish of St. Felix de Valois, for the construction of an iron bridge in this parish. The plans and specifications can be seen every day at the Office of the corporation. J. H. Lavallee, sec.-treas.

Winnipeg, Man.—Tenders, addressed to the Chairman, Board of Control, will be received up to April 16, for the supply of labor and materials required in the erection of a 150 foot brick or concrete chimney for the Elmwood Incinerator. Plans, specification and form of tender may be obtained at the office of the City Engineer, 223 James Avenue.

Winnipeg, Man.—Tenders addressed to the Commissioners of the Greater Winnipeg Water District will be received up to April 16, for the supply of miscellaneous bronze castings, brass piping, etc., which enter into the construction of a Venturi meter. Specifications and form of tender may be obtained at the offices of the district, 501 Tribune Building, Winnipeg.

Winnipeg, Man.—Tenders addressed to R. D. Waugh, Chairman of the Com-

missioners, Greater Winnipeg Water District, up to April 16, for the supply of approximately 12,000 feet of 48-inch and 1,300 feet of 60-inch cast iron pipes, together with numerous specials and gate valves. Specifications may be obtained upon application to the offices of the District, 501 Tribune Bldg., Winnipeg.

Winnipeg, Man.—Tenders, addressed to the chairman, Greater Winnipeg Water District Commission, at 501 Tribune Building, Winnipeg, will be received up to April 16, 1917, for the supply of one second-hand passenger coach, also one second-hand caboose, both standard gauge. Tenderers to supply own specifications. Further particulars on application to undersigned, R. D. Waugh, Chairman of Commissioners.

Hamilton, Ont.—Tenders addressed to Chairman of Board of Control will be received up to April 5 for the supply and delivery of one combined motor driven flusher and sprinkler to conform to the following general specifications: Tank capacity, 1,200 Imperial gallons; truck not less than 5-ton; separate motor for flusher apparatus. Further particulars on application to the Secretary of Works Department, City Hall, Hamilton.

PERSONAL

William Walker has been appointed Aeling Division Engineer, Eastern lines, Grand Trunk Railway, vice F. L. C. Bond, enlisted for Overseas Service.

Hon. Col. Harry Cockshutt, president of the Cockshutt Plow Co., has been appointed president of both the Brantford Carriage Co. and the Adams Wagon Co. in succession to the late J. A. Sanderson.

John G. Sullivan, of Winnipeg, chief engineer C.P.R. Western lines was elected president, at the closing session of the eighth annual convention of the American Railway Engineering Association at Chicago.

Michael J. McAndrew, of St. Thomas, Ont., traveling engineer of the Michigan Central Canadian lines, died suddenly at Victoria, Ont., on March 19. Mr. McAndrew was born at Niagara Falls, Ont., in 1859. He was appointed traveling engineer in 1906.

Anson J. Hopkins, who has been with the Canadian Fairbanks-Morse Co., in Vancouver, was recently appointed general head of the accessory department of that company, and is now organizing the work of this department in the firm's eleven branches.

Francis S. McMath, president of the Canadian Bridge & Iron Works, Walkerville, Ont., has been appointed a member of the Detroit Municipal Street Railway Commission. The commission is urged by the Mayor to begin quick work on the subway plans to relieve street congestion across the river.

Harold C. Upton has been appointed manager of the machine tool department of the Toronto branch of the Canadian Fairbanks-Morse Co. Mr. Upton has

been with the company over nine years, at the Toronto office, having passed through all the departments. For the past three years he has been city traveler on general lines for the various departments.

George Henry Frost, founder and for many years publisher of *Engineering News*, died March 15 at his home in Plainfield, N.J., aged 79 years. He was born in West Hawkesbury, Ont., and was graduated from McGill University, Montreal, as a civil engineer in 1860. His civil engineering experiences covered surveying work in Wisconsin for the Chicago & Northwestern Railroad. In April, 1874, he brought out the first number of the *American Architect and Surveyor*, a monthly sheet, which in 1876 he made a weekly and renamed *Engineering News*. This in 1911 he sold to the Hill Publishing Co., New York City.



Steel Shell Forgings or Billets of any size or weight will move any distance or about curves upon our specially constructed Gravity Carriers and Incline or Horizontal power devices. No labor required.

Canadian Mathews Gravity Carrier Co., Toronto, Ont.

CONTRACTS

Tecumseh, Ont.—Canadian Allis-Chalmers Ltd., Toronto, have been awarded a contract for the pumps and electrical equipment for the waterworks system by the Eau Claire Waterworks Co.

Fredericton, N.B.—The local School Board has awarded the contract for the erection of the Charlotte Street School extension to R. A. Corbett, of St. John, at \$17,000, and for the heating and plumbing to R. Chestnut & Sons, of Fredericton, at \$6,000.

Port Arthur, Ont.—The Fegles-Bellows Engineering Co. has been awarded the contract of the construction of a complete grain treating plant for the Western Grain Co. new elevator to be erected on the same site as that of the Western Terminal elevator on the Kaminstiquia River. The plant, which will have a total capacity of 175,000 bushels is to be built according to plans designed by the contracting company.

Hamilton, Ont.—Contracts for annual supplies have been awarded as follows: Brass work, H. Mueller Mfg. Co., Sarnia; special brass castings, Talman Brass Works, Hamilton; cast-iron pipe, Gartshore-Thomson Pipe & Foundry Co., Hamilton, \$58 per ton, special castings, 5½ lb.; castings, Canada Iron Foundries, Ltd., Toronto, 5 lb.; lead pipe, Talman Brass Works, Hamilton, 15½ lb.; lubricating oils, Imperial Oil Co., Toronto; valves, Kerr Engine Works, Walkerville, 1 in. gate valves \$11.50 each f.o.b. Hamilton.

Toronto, Ont.—The request of Canadian Allis-Chalmers, Ltd., to be released from a contract to supply six-inch cast iron pipe at \$26.75 per length for the York Township water supply system was acceded to by the Township Council at a special meeting held here on March 21. The tender of the Canadian Allis-Chalmers, Ltd., to supply two 12-inch valves at \$65 each was accepted as was that of Drummond, McCall and Co., for 200 six-inch stop valves at \$29.65 each and 83 12-inch stop valves

MORTON MANUFACTURING CO.
 PORTABLE PLANERS
 DRAW CUT SHAPERS
 SPECIAL DRAW CUT R R SHAPERS
 FINISHED MACHINE KEYS
 STATIONARY & PORTABLE KEY WAY CUTTERS
 SPECIAL LOCOMOTIVE CYLINDER PLANERS
 OFFICE AND WORKS: MUSKOGON HEIGHTS U.S.A.

OVENS
 Enameling and Varnishing Ovens heated by Gas, Electricity, Steam or Coal. Write for Booklet.
Brantford Oven & Rack Co., Ltd.
 Brantford, Canada.

We Know

you are anxious to buy
Canadian Made
 goods.

The Imperial

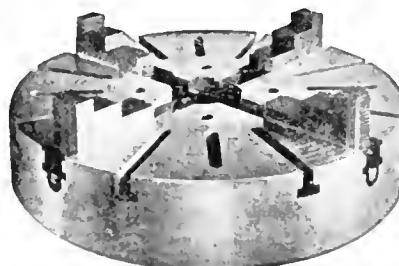

Chuck

is manufactured by
Ker & Goodwin
 Brantford, Canada

METAL STAMPINGS

We are manufacturers of stamped parts for other manufacturers.

We do any kind of sheet metal stamping that you require. Our improved presses and plating plant enable us to produce the finest quality of work in a surprisingly short time.

We can finish steel stamping in Nickel, Brass or Copper.

Send us a sample order.

W. H. BANFIELD & SONS
 372 Pape Avenue, Toronto, Can.

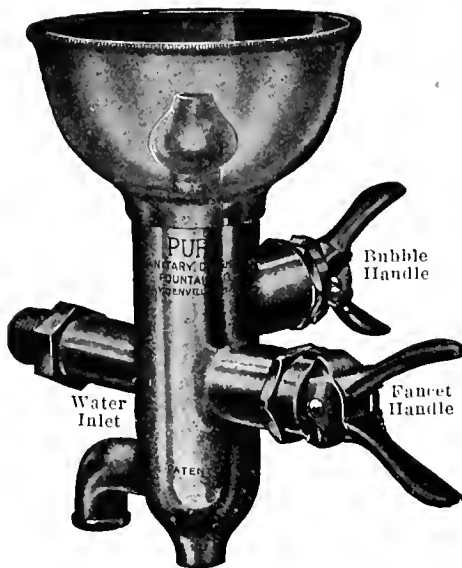

Saving or Wasting?

The manner in which you handle the drinking water problem in your plant may seem to be a small matter to you—but investigate. The results will be surprising.

The old-time faucet is costly. Running hour after hour, day after day, its ceaseless flow is costing you money, yet without any better service.

Puro Saves 35%

A Puro Sanitary Drinking Fountain will cut that water bill 35%. We can prove that it has done that for others.

It will give every employee a safe, saner draught of bubbling water free from the contamination of the common drinking cup.

In a word, it is the only sanitary Drinking Fountain that is really safe, sanitary, simple, automatic in control, and easy to attach.

"PURO - FY"

(MADE IN CANADA)

YOUR WATER SUPPLY

Puro Sanitary Drinking Fountain Company
147 University Ave., Toronto, Canada

THE IRON WORKS

Successors to

LIMITED

Owen Sound Iron
Works

Owen Sound,
Ont.

Engineers

Boiler-
makers

Founders

Machinists

Tank Work
Smoke Stacks,
Grey Iron and
Brass Castings,
Special
Machinery
Made to
Order

at \$72.80 each. Tenders for hydrants will be called for shortly. Frank Barber is Township Engineer.

MARINE

Port Hope, Ont.—Acting upon the suggestion of the Department of Marine, the Port Hope Harbor Board will have the white light on the Port Hope lighthouse changed to a red light, as the white light was liable to be confused with the town lights.

Pictou, N.S.—At a well attended rate-payers meeting held on March 22, a resolution was unanimously passed authorizing the Town Council to ask for legislation to bonus a proposed steel shipbuilding plant to the amount of \$50,000.

Vancouver, B.C.—The Grand Trunk Pacific steamer Prince Rupert, Captain Duncan McKenzie, running between Prince Rupert and Vancouver, is ashore on Conn. Island, one mile east of Lawyer's Island light, and is reported badly damaged.

Ottawa, Ont.—J. A. Cunningham, of Vancouver, president of the Manufacturers' Association of British Columbia, was in Ottawa recently in connection with the closing of a contract with the British Imperial authorities for three 8,000-ton steamships to be built on the Pacific coast.

Toronto, Ont.—To protect the Canadian Government from loss on the Toronto Harbor dredging contract, the National Surety Company of New York has completed all formalities in connection with the \$500,000 bond guaranteeing completion of the contract by Canadian Stewart Co., the contractors. The work will require four years time to complete.

BUILDING

Dundas, Ont.—The John Bertram Sons & Co., will erect an office building immediately at a cost of \$30,000.

Brantford, Ont.—The contract for the erection of the new Loew's Theatre in Hamilton has been awarded to P. H. Seord & Son, of this city, at \$250,000.

Toronto, Ont.—The Board of Education inspectors report that several public schools require better ventilation and other improvements. It is likely that a number of fans will be installed.

Toronto, Ont.—Messrs. J. & Frank Walsh have purchased a site at 626 King Street, West, and will erect a three storey factory building which can be utilized for light manufacturing.

Magrath, Alta.—Arrangements are being completed for the erection of an elevator here and also one at Raymond and two others at points along the local railway line. Contract for lumber has been let.

Saskatoon, Sask.—A five-storey concrete and brick warehouse, costing in the neighborhood of \$125,000 and covering an area of 60 by 124 feet, is to be erected here this spring by a large merchandise company.

INCORPORATIONS

Vancouver Forge Co., has been incorporated at Victoria with a capital of \$25,000 to carry on a blacksmith and forge business at Vancouver, B.C.

Sidney Mills Ltd., have been incorporated at Victoria with a capital of \$200,000 to operate sawmills, planing mills etc. at Sidney, B.C.

Fort Steele Lumber Co., has been incorporated at Victoria with a capital of \$25,000 to carry on business as sawmill proprietors at Fort Steele, B.C.

The Malahat Motor-Ship Co., has been incorporated at Victoria, B.C., with a capital of \$100,000 to build and operate motor-ships and steam ships with head office at Vancouver, B.C.

The Eburne Clear Cedar Mills, Ltd., has been incorporated at Victoria with a capital of \$50,000 to carry on business as shingle manufacturers and take over the B. K. Shingle Co. of Vancouver.

The Air Cooled Burner Co., of Chehalis, Washington, has been authorized to manufacture refuse burners and machinery of all kinds. The capital is \$100,000 and office is at Vancouver, B.C.

Akerberg, Thomson & Co., Ltd., has been incorporated at Victoria, B.C., with a capital of \$45,000 to carry on the business of machinists, mechanical and electrical engineers at Prince Rupert, B.C.

Vancouver Engineering Works Ltd., has been incorporated at Victoria, B.C., with a capital of \$1,000,000 to carry on the business of marine engineers, iron and steel founders, and boiler makers, etc., at Vancouver.

Ladysmith Smelting Corporation Ltd., has been incorporated at Victoria, B.C., with a capital of \$1,000,000 to acquire the Tye Copper Co., and to carry on the business of a smelting and refining company. The head office is at Victoria, B.C.

George W. Cole Ltd., has been incorporated at Ottawa with a capital of \$50,000 to carry on business as mechanical engineers, tool makers and founders, etc., at Toronto. The incorporators are George W. Cole, James L. Ross and L. B. Campbell all of Toronto.

The Canadian Wood Molybdenite Co., has been incorporated at Ottawa with a capital of \$1,000,000 to carry on the business of mining and manufacturing molybdenite or any other minerals with head office at Ottawa. The incorporators are O. E. Wood, Harvey Fitzsimons and George D. Kelly all of Ottawa.

Canada Lock Joint Pipe Co., has been incorporated at Ottawa with a capital of \$40,000 to take over the Canadian interests of the Lock Joint Pipe Co., an American corporation, and to construct part of the pipe line of the Greater Winnipeg Water District. The head office is at Winnipeg and the incorporators are Alexander Smith, William Currie and Harold Spencer all of Winnipeg.

CATALOGUES

Power Hammers.—A new pamphlet issued by the United Hammer Co., of Boston, Mass., illustrating and describing the "Fairbanks" power hammers. An illustrated list of parts is included with telegraph code for convenience when ordering parts.

The Independent Pneumatic Tool Co., Chicago, Ill., have issued a new and unusually attractive 94 page catalogue No. 10 bearing the title "Thor" and dealing with an interesting line of pneumatic and electrical tools. The principal features of construction and materials used are described at length together with illustrations of details and sectional views of the air drills and hammers, etc. The various types of tools are all illustrated accompanied by a description while tables are included giving the principal dimensions of each size and work for which each is adapted. Another series of illustrations show the "Thor" pneumatic tools in operation at a number of plants under a variety of conditions. "Universal" electric drills are also described and illustrated while the concluding pages are devoted to particulars of chisels and rivet sets.

Dynamos and Motors.—Pamphlet No. 21-C, recently issued by Bruce Peebles & Co., Ltd., Edinburgh, Scotland, illustrates and describes the "Peebles" self-contained continuous current dynamos and motors. A full specification is included covering these machines which are made in various types such as protected type, semi-enclosed, totally enclosed, mining or pipe ventilated type. The first half is taken up with the specification, while in the latter half very complete lists of output ratings are given for the usual standard voltages, and for every size of machine which they manufacture, separate output ratings being given for each of the five different types enumerated above. To assist intending purchasers in laying out their plant, there are also given two pages of approximate weights and dimensions, while on the last page there is an illustration of two machines mounted together, and arranged as an ordinary motor generator, booster or three-wire balancer. Copies of this pamphlet will be gladly sent to anyone interested.

BOOK REVIEWS

Metal Statistics for 1917.—The tenth annual edition of this useful publication has recently been published by the American Metal Market, New York city. All the tables have been carried forward another year and some new data incorporated, giving the comparative figures a still broader scope. Among the new features introduced is a buyers' directory printed on colored paper. The accuracy of the figures is unquestioned, as the statistics relating to both ferrous and non-ferrous metal production have been obtained from the most reliable sources. It is an extremely useful handbook for buyers and sellers of metals and also plant managers.

"Barnes-Made" SPRINGS

are unusual in service and wear

They are the result of sixty years' experience, unsurpassed equipment and highly skilled workmanship.

A trial will convince you that "Barnes-Made" Springs are the best buy.

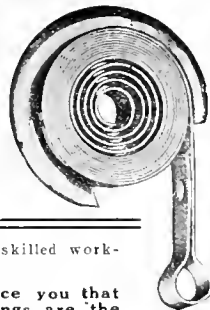

Established 1857.

THE WALLACE BARNES COMPANY
218 South St., Bristol, Ct., U.S.A.
Mfrs of "Barnes-made" Products
Springs, Screw Machine Products, Cold Rolled Steel and Wire

Oxy-Acetylene Welding

We can give the best of service in all kinds of welding repair jobs. We have successfully repaired the most difficult jobs. Our work is high-class and our prices moderate.

Send us your work or write us regarding it.

TORONTO WELDING CO.
26 Pearl St., TORONTO

GAUGES

DIES, TOOLS AND REPAIRS
OXY-ACETYLENE WELDING

WORTH ENGINEERING CO.
163 Spadina Ave., Toronto, Ont.
Phone Adel. 3734

B. H. AYLSWORTH A. E. HACKWORTH

MacKinnon, Holmes & Company, Limited

Design, manufacture and erect all classes of Steel Work.

Specialties:-

- Bridges
- Oil and Water Tanks
- Penstocks
- Coal and Coke Bins
- Smoke Flues & Stacks.

Prompt deliveries assured.

Designs and Estimates from Head Office at

SHERBROOKE, QUE.

MAPLE LEAF
STITCHED COTTON DUCK
BELTING
DOMINION BELTING CO. LTD.
HAMILTON CANADA

"HAWK" D
CHROME
VANADIUM
STEEL

Will
Give You
Exceptional

Shell Forging Production

WITHOUT AN EQUAL FOR BOTH FIRST AND SECOND OPERATION PUNCHES.

Comes to you heat-treated and ready for use.

It does not stick to the work.

There are many cases where each punch has turned out over 2,000 shells.

It means more shells, per machine per day.

STEEL OF EVERY DESCRIPTION.

Hawkrige Brothers Company

303 Congress St., BOSTON, MASS.
U. S. A.

Classified Advertising Section

Rates (payable in advance): Two cents per word first insertion; one cent per word subsequent insertions. Count five words when box number is required. Each figure counts as one word. Minimum order \$1.00. Display rates on application.

FOR SALE

FOR SALE AT A BARGAIN—1 15" style D geometric die head, with extra dies. White Machine Works, Windsor, Ont. c16m

GAP LATHE, 28 x 42 x 16 FT. BED, FOR sale, cheap; also emery wheel stand, power hack saw. Guarantee Motor Co., Hamilton, Ont. (tf)

FOR SALE—ONE 450 H.P. THOMPSON & Williams condensing engine. Will sell cheap. Engine is in first-class repair and will give every satisfaction. Apply J. A. Marven, Limited, Moncton, N.B. tcfm

NEW BOILERS, CHEAP—2 30 H.P. AND 1 50 H.P. open bottom, locomotive type boilers, complete with fittings for 125 lbs. working pressure. Can deliver from stock either east or west of Great Lakes. The Canadian Fairbanks-Morse Co., Ltd., 300 Princess St., Winnipeg, Man. c13m

FOR SALE—IN FIRST-CLASS WORKING order—second-hand General Electric direct current generator, 35 K.W., 220 volts, arranged for belt drive, complete with sliding base, etc. Address Canada Forge Company, Welland, Ontario. c13m

FOR SALE—TWELVE PRACTICALLY new No. 7-C Racine Heavy Duty High Speed Hack Saw Machines. Suitable for all Cutting purposes. Immediate delivery. For Price and further information address The Peck Rolling Mills, Limited, Montreal. c14m

ONE LATHE 16" x 4½" back geared. Built by P. P. Silk Machine & Tool Co., Cincinnati, Ohio. One lathe 18" x 3", back geared. Built by the Bradford Mill Co., Cincinnati, Ohio. Four Murehey Collapsible Dies. Capacity 1½" to 2½". Box 272, Canadian Machinery. ctmf

FOR SALE—2 KENNEDY CUTTING-OFF machines, for cutting off both ends of 4.5 H.E. forgings; in good condition; price \$750 each. 1 18-pdr. Holden-Morgan thread miller for threading base end of high explosive shells; price \$300. 1 18-pdr. H.E. marking machine; price \$50. Apply to Alton Foundry Co., Ltd., Alton, Ontario. c13m

WE OFFER THE FOLLOWING MACHINERY and tools at exceptionally low prices:—1—Heavy Duty Rockford Drill 24". Suitable for heavy work, in use only two months. 4—Jones & Lamson Turret Lathes, Bar Machines. Size 2 x 24. Price \$200.00 to \$250.00 each. 2—Jones & Lamson Turret Lathes, Chucking Machines. Size 2 x 24. Price \$200.00 each. 1 Small Turret Lathe, 1½" Hole in Spindle, 1¼" Hole in Turret Head. 1—Two Spindle Sensitive Drill \$100.00. 2—Holden-Morgan Thread Millers, slightly used on 4.5 Shells. 4—Bertram Internal Thread Millers. 2—No. 9 Hartness Dies. Capacity range 1¼" to 5" Dia. 4—12" Whiton Universal Scroll Heavy Duty Chucks, 3-Jaw. 1 10" Skinner Universal Chuck, 3-Jaw. 1—10 x 12 35 H.P. Robb Horizontal Steam Engine, in first-class condition. Apply Steel Furnishing Company, Limited, New Glasgow, N.S. c0w17

FOR SALE

ONE No. 2 WHITING CUPOLA, 36" SHELL capacity, one to two tons per hour. In perfect condition, used only for two heats. Address Purchasing Agent, Canadian Ingersoll-Rand Co., Ltd., Sherbrooke, Que. ctmf

SITUATIONS WANTED

MECHANICAL ENGINEER WITH LONG experience designing and estimating on machine tools, special shell machinery, tools, jigs and fixtures, desires responsible position with well established company. Best of references given from well-known companies. Box 284, Canadian Machinery. c12m

SUPERINTENDENT WITH NINETEEN years' mechanical experience in manufacturing and repairing of machinery and structural steel, both shop and erection, desires change of position. Experienced in machining 18-Pr. and 4.5" high explosive shells. Aggressive character, good organizer, best of references. Box 282, Canadian Machinery. c12m

SUPERINTENDENT OR WORKS MAN-ager of large metal working plant desires change. Broad gauge man of modern methods and a producer of results. Over 20 years' experience at handling large forces of workmen in manufacture of high quality and interchangeable goods of brass, iron and steel, special tools, dies, machinery, etc. Includes brass works, machine shop, punching and stamping and fine brass work, taking entire control of plant. English-American descent. Box 280, Canadian Machinery. c15m

A Page of Opportunity

Here are opportunities galore! Opportunities for toolmakers, machinists, superintendents, salesmen. Opportunities for the buyer of machinery, for the employer of help.

Opportunity is knocking here every week. It will be knocking for you some week. Make sure it will find you in.

Read these pages every week!

Canadian Machinery

Classified Advertising Section

143 University Ave., Toronto, Ont.

WANTED

WANTED—LATHE ABOUT 48" SWING or larger, also boring mill up to 60". Must be in good order and reasonable price. Apply Box 288, Canadian Machinery. c16m

SPECIAL MACHINERY

MANUFACTURERS—WE CAN UNDER-take work to any specification—munition production equipment or otherwise. Write W. H. Sumbling Machinery Co., 7 St. Mary St., Toronto.

SITUATIONS VACANT

WANTED MACHINERY SALESMAN TO handle Toronto and Western Ontario. Apply, giving experience to Box 285 Canadian Machinery. c14m

MECHANICAL ENGINEER WANTED—first-class opportunity for the right party. Must be energetic, ambitious, sober and have some knowledge of French. Apply Box 286, Canadian Machinery. tcmf

MAN ABOUT 30, WITH ENGINEERING and commercial training, experienced in mine and smelter requirements, including structural and cast steel work. A man with office experience and capable of soliciting business preferable. Box 283, Canadian Machinery. c13m

EXPERIENCED TOOL MAKERS, SCREW machine hands and general mechanics wanted at once for new, well lighted plant (not munitions), situated just outside of Toronto; highest union wages and steady work for good men. Mention this paper. Canada Cycle and Motor Company, Limited, Weston, Ont. c13m

A GOOD SALES ENGINEER TO OPEN office to sell Moline Heat in Canadian territory. Must be a good salesman, having had a general heating and ventilating experience. Must give good references. We have a fine proposition for the right man. Address, Moline Heat, Moline, Ill. ctmf

SUPERINTENDENT WANTED—IN CAN-adian city—A thoroughly competent and experienced man to take charge of a plant manufacturing high grade automatic screw machine products and similar lines. Plant thoroughly equipped with modern machines. Man must be a thorough mechanic with good education, of unquestionable character, and able to handle men and get results. Must be capable of keeping an organization tuned up to a high state of efficiency. This is an excellent opportunity for a capable man with plenty of energy to create a permanent position for himself. Would not be adverse to training a young man who has the necessary ability and ambition. Duties to begin April 15. Apply Box 287, Canadian Machinery. c13m

CANADIAN MACHINERY

AND MANUFACTURING NEWS

A weekly newspaper devoted to the machinery and manufacturing interests.

Vol. XVII.

TORONTO, APRIL 5, 1917

No. 14

EDITORIAL CONTENTS

Intensifying Our Shipbuilding And Marine Engineering Industries	331-346
Production Methods and Devices	347-348
Making Expansion Taps....Water-Cooled Pin for Nosing Die....Special Heavy Collet Chuck....Saving Lead in the Hardening Bath....Cutting Well Drill Threads.	
Spokes in Industry's Wheel	349
Herbert William Carter.	
General	350
Demonstration of Metal-Spraying Process....Technical Men Give Aid....New Zealand Trade for Canada....Moving Pictures of Munitions Making.	
Editorial Correspondence	351-354
Machinists' Instruction Course—XVII....Boiler Patching with Oxy-Acetylene Reclaiming Scrap Cylinders....Kerosene as a Gas Engine Fuel.	
General	354-355
Comparative Tests of Uranium and Other High-Speed Steels....Safety in the Machine Shop—The Automatic Department.	
Editorial	356
Possible Effects of United States Entry into the War....Ascendancy of British Industrial Influence.	
Industrial Notabilities	357
James Anderson Coulter.	
Selected Market Quotations	358-359
The General Market Condition and Tendency	359-362
Montreal Letter....Toronto Letter....Sydney Letter.	
Industrial and Construction News (Advtg. Section)	70

THE MACLEAN PUBLISHING COMPANY, LIMITED

JOHN BAYNE MACLEAN, Pres. H. T. HUNTER, Vice-pres. H. V. TYRRELL, Gen. Man.

Publishers of Hardware and Metal, The Financial Post, MacLean's Magazine, Farmer's Magazine, Canadian Grocer, Dry Goods Review, Men's Wear Review, Printer and Publisher, Bookseller and Stationer, Canadian Machinery and Manufacturing News, The Power House, The Sanitary Engineer, Canadian Foundryman, Marine Engineering of Canada.

Cable Address: Macpubco, Toronto; Atabek, London, Eng.

ESTABLISHED 1887.

CANADIAN MACHINERY AND MANUFACTURING NEWS

PETER BAIN, M.E., Editor. B. G. NEWTON, Manager.
Associate Editors: A. G. WEBSTER, J. M. WILSON, J. H. RODGERS.

CHIEF OFFICES:

CANADA—Montreal, 701-702 Eastern Townships Building; Toronto, 143-153 University Ave., Telephone Main 7324; Winnipeg, 22 Royal Bank Building, Telephone Garry 2313.

GREAT BRITAIN—LONDON, The MacLean Company of Great Britain, Limited, 88 Fleet Street, E.C., E. J. Dodd, Director. Telephone Central 12960. Cable Address: Atabek, London, England.

UNITED STATES—New York, R. B. Huestls, 115 Broadway, N.Y., Telephone Rector 8971; Boston, C. I. Morton, Room, 733, Old South Building, Telephone Main 1204. A. H. Byrne, 11015-6-7 Fort Dearborn Bldg., 105 W. Monroe St., Chicago, Telephone Randolph 3234.

SUBSCRIPTION PRICE—Canada, Great Britain, South Africa and the West Indies, \$3.00 a year; United States, \$3.50 a year; other countries, \$4.00 a year; Single Copies, 15 cents. Invariably in advance.

Hendey Experimental 12" Lathe

For the Laboratory or Experimental Department where the best of its kind is wanted, and each machine must be motor-driven, here is the Lathe in this HENDEY 12".



In addition to its complete regular equipment it has Small Tool Cabinet for operators' fine tools, also gear closet for extra gears to cut special threads.

Write for Descriptive Matter.

The Hendey Machine Co.

Torrington, Conn., U.S.A.

Canadian Agents: A. R. Williams Machinery Co., Toronto, Ont.; A. R. Williams Machinery Co., 260 Princess St., Winnipeg; A. B. Williams Machinery Co., Vancouver; A. B. Williams Machinery Co., St. John, N.B.; Williams & Wilson, Montreal.

INDEX TO ADVERTISERS

A		D		J		R		
Acme Mach. Tool Co.	6	Davenport Loco. Works	26	Jacobs Mfg. Co.	155	Hacine Tool & Machine Co.	129	
Aikenhead Hdw. Co.	71	Davies-Bourbonville Co.	149	Jardine Co., A. B.	153	Reed-Prentice Co.	35	
Albany Pump Co.	74	Davis, W. F., Machine Tool Co.	83	Jenckes Mach. Co.	9	Reliance Mach. Co.	110	
American Pulley Co.	106	Davis & Co., J. A.	194	Jahborn, Geo. E.	75	Ricket-Shaper Co.	103	
Armstrong Bros. Tool Co.	140	Deloro Smelting & Refining Co.	19	Johnson Mach. Co., Carlyle	8	Riverside Machy. Depot	80	
Armstrong, Whitworth of Canada	17	De Mooy Mach. Co.	153	Joyce, Geo. A., Co.	141	Rivett, Lathe & Grinder Co.	158	
Atkins, Wm., & Co., Ltd.	17	Dept. of Finance	157	Jersey City Mach. Co.	142	Rockford Drilling Machine Co.	151	
Atlas Crucible Steel Co.	9	Detroit Pneumatic Chuck Co.	132	K	Roelofson Machine & Tool Co.	21		
Aurora Tool Works	151	Diamond Saw & Stamping Works	128	Kasenit, Limited	100	Roper & Co., C. F.	107	
B		Dillon Mfg. Co.	89	KempSmith Mfg. Co.	117	S		
B. A. B. Mold Mfg. Co.	87	Dodge Mfg. Co.	105	Kennedy, Wm. & Sons	20	Shore Instrument Co.	149	
Babcock & Sons	74	Dominion Forge & Stamping Co.	114	Kidston & Co., A. G.	18	Shuster Co., F. B.	139	
Baird Machine Co.	140	Dominion Iron & Wrecking Co.	122	L	Sidney Tool Co.	118		
Banfield, E. J.	50	Dominion Machinery Co.	81	L'Air Liquide Society	98	Silberberg, M. J.	104	
Banfield, W. H., & Sons	75	Dominion Steel Foundry Co.	139	Lands Machine Co.	140	Silver Mfg. Co. Co.	155	
Barnes, W. F., & John	75	E	Eastern Mach. Screw Corp.	156	LeBlond Mach. Tool Co., R. K. A.	15	Simmons Mach. Co., Inc.	78, 85, 126
Barnes, Wallace Co.	152	Elmes, Chas. F.	98	Latrobe Elect. Steel Co.	16	Skinner	149	
Bertram, John, & Sons Co., Ltd.	1	Erle Foundry Co.	145	M		Slocum, Avram & Slocum	136	
Bellvue Industrial Furnace Co.	162	F		Macnab, John, Machy. Co.	32	Standard Alloys Co.	12	
Blake Pump & Condenser Co.	27	Fetherstonhaugh & Co.	74	Marion & Marion	74	Standard Mfg. Co.	113	
Blackall, Fred S.	111	Fitzgerald, W. H. J.	80	Manufacturers Equipment Co.	134	Standard Tube & Fence Co., Ltd.	148	
Brantford Oven & Rack Co.	75	Ford-Smith Mach. Co.	115	Marsh & Henthorn, Ltd.	99	Starret Co., L. S.	97	
Brizeford Mach. Tool Works	5	Foss & Hill Machy. Co.	115	Matthews, Jas. H., & Co., Inc.	33	Stecher Co., Chas.	112	
Bristol Company	139	Inside back cover		McCabe, J. J.	31, 41	Steel Co. of Canada	3	
Brown, Roges	11	Fox Machine Co.	89	McCoy-Brandt Machy. Co.	89	Steinle Turret Mach. Co.	25	
Brown Engineering Corp.	85	Francis & Co.	141	McDougall Co., H., Inside back cover	139	Stout, John, Co.	36	
Brown & Sharpe	145	G		Mechanical Engineering Co.	101	Stocker-Rumley-Wachs Co.	96	
Brown & Zor man Machy. Co.	82	Galt Mach. Screw Co.	86	McFarland Mfg. Co.	98	Stow Mfg. Co.	96	
Brownell Machy. Co.	84	Gardner Machine Co.	141	Metals Coating Co.	100	Sturtevant Co., B. F.	94	
Brown's Copper & Brass Rolling Mills	91	Garlock-Walker Machy. Co.	51	Millers Falls Co.	125	Swedish Steel & Importing Co.	6	
Buden, Hanbury A.	74	in Machine Co.	119	Miller, Smythe Elect. Co.	79	Symington Co., T. H.	120, 121	
Butterfield & Co., Ins.	157	Geometric Tool Co.	69	Millholland Co., W. K.	79	T		
C		Shore Instrument Co.	102	Montreal General Tool Co.	25	T. C. M. Mfg. Co.	118	
Can. Bond Hanger & Coupling Co.	166	Gilbert & Barker Mfg. Co.	163	Monarch Brass Mfg. Co.	87	Tabor Mfg. Co.	128	
Canada Machinery Corporation	106	Globe Machine & Stamping Co.	83	Monarch Machy. & Supplies	147	Taylor Instrument Co.	130	
Outside back cover		Golbie & McCulloch Co.	79	Modern Tool Co.	151	Thomas Elevator Co.	101	
Canada Metal Co.	99	Gosnell-Pratt Co.	114	Morton Mfg. Co.	75	Thwing Instrument Co.	101	
Canada Wire & Iron Goods Co.	140	Gooley & Elmhut, Inc.	111	Murphy Machine & Tool Co.	135	Toronto Iron Works	139	
Can. E. K. Morton Co.	19	Grant Mfg. & Machine Co.	145	N		U		
Can. Fairbanks-Morse Co.	125	Grant Gear Works, Inc.	142	National Electric Welder Co.	92	United Tool Chest Works	141	
Can. Desmont-Stephan Mfg. Co.	125	Graton & Knight Mfg. Co.	149	National Machine Tool Co.	141	United States Electrical Tool Co.	124	
Can. Drawn Steel	140	Greenfield Machine Co.	127	New Britain Mach. Co.	25	V		
Can. Economic Lubricant Co.	167	H		New York Machinery Exchange	81	Vanadium Alloys Steel	14	
Can. Inspection & Testing Laboratories, Ltd.	129	Hamilton Gear & Machine Co.	86	Nicholson File Co.	174	Vactor Tool Co.	133	
Can. Hanson & Van Winkle Co.	139	Hamilton Machine Tool Works	24	Niles-Bement-Pond, Inside front cover	146	Vulcan Crucible Steel Co.	95	
Can. Steel Foundries, Ltd.	7	Hanna & Co., M. A.	6	Noble & Westbrook Co.	146	W		
Can. S. K. F. Co.	1	Hardinge Bros., Inc.	22	Northern Crane Works	198	Walton Co.	136	
Can. Welding Works	100	Hawkrige Bros.	72	Norton, A. O.	142	Walcott Lathe Co.	30	
Carborundum Co.	126	Hendey Machine Co.	169	Norton Co.	34	Webber Bros. Mach. Co.	18	
Carlyle Johnson Mach. Co.	128	Himelf, John T.	149	Nova Scotia Steel & Coal Co.	13	Wells Bros. of Canada	34	
Chapman Double Ball Bearing Co.	167	Hollander Machy. Co.	79	O		West Tire Setter	98	
Chapman Iron & Steel Co.	115	Holz, Herman A.	102	Osborne & Sexton Machy. Co.	79	Whiting Foundry Equipment Co.	18	
Cincinnati Milling Mach. Co.	117	Houston, Stanwood & Gamble Co.	119	Oven Equipment & Mfg. Co.	96	Williams, A. R., Mach. Co.	7, 15, 69	
Cincinnati Pulley Machy. Co.	153	Boyt Metal Co.	142	Parmenter & Bulloch Co.	179	Williams, J. H., & Co.	164	
Clark Equipment Co.	149	Hungerford Brass & Copper Co.	91	Peerin, Wm. R.	99	Williams Tool Co.	127	
Cleveland Milling Mach. Co.	28	Hurlbut-Rogers Machinery Co.	142	Peerless Machine Co.	198	Wilt Twist Drill Co.	152	
Cleveland Twist Drill Co.	147	Hyde Engineering Works	119, 124	Petrie, of Montreal, Ltd., H. W.	29	Wissor Mach. & Tool Works	127	
Combet Foundry & Mach. Co.	119	I		Petrie, H. W., Ltd.	79	Wing & Son, J. E.	75	
Cook, Asa S.	141	Ideal Tool & Mfg. Co.	136	Positive Clutch & Pulley Works	15	Winnipeg Gear & Engineering Co.	86	
Cullen Machy. Co., C. W.	89	Illinois Tool Works	73	Radio Electric Co.	72	Wisconsin Electric Co.	123	
Cushman Chuck Co.	14	Independent Pneumatic Tool Co.	124	Dart & Whittner, Inside front cover	72	Wright Mfg. Co.	89	
Curtis Pneumatic Machy. Co.	168	Iron Works, The	75	Deale, R. E. T. Ltd.	74	Z		
		Inter-Continental Machy. Corp.	82	Puro Sanitary Drink'g Fountain Co.	76	Zenith Coal & Steel Products Co.	140	

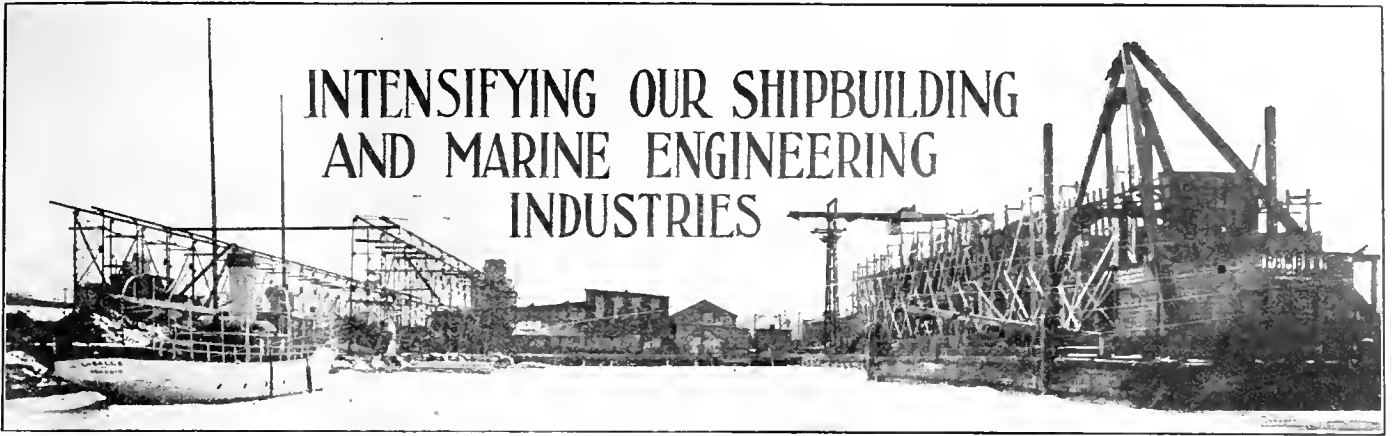

INTENSIFYING OUR SHIPBUILDING AND MARINE ENGINEERING INDUSTRIES

SHIP-BUILDING PLANT OF THE THOR IRONWORKS, "TORONTO" LOOKING FROM OFF SHORE.

By "Drifter"

Indications are not wanting that shipbuilding in Canada may not only again flourish, but may quite readily surpass in achievement that of bygone years. Wood ship construction has been revived and promises for a time at least to develop into an industry of considerable proportions. Steel shipbuilding has been given a great impetus, however, and of course to it, more than the other, we look for permanence, and that of a really substantial nature.

THE persistency with which Germany is waging war against the water-borne commerce of the world is certainly not surpassed by her activities in the field, and when results are analysed in each case, and given their proper value relative to the headway we are making towards ultimate and complete victory, it must be admitted that the price being paid in ships on the one hand is equally as costly and as

highly undesirable as that being paid in men's lives on the other.

In the past two months, something like one million tons of shipping have fallen victim to mines and submarines. Of itself, this record is sufficiently staggering, although when examined closely, it is seen to be but a more extreme development of a process now many months operative, and which has for its avowed objects either the terror-

ising of ocean commerce to the point of cessation, or the practical annihilation of same if effort be made to maintain it. The loss of tonnage during February and March of this year through the activities of enemy submarines, and the broadcast sowing of enemy mines on the steamship lanes of the Seven Seas, has been highly abnormal as compared with preceding months of piratical effort, just as much so in that feature as any of the

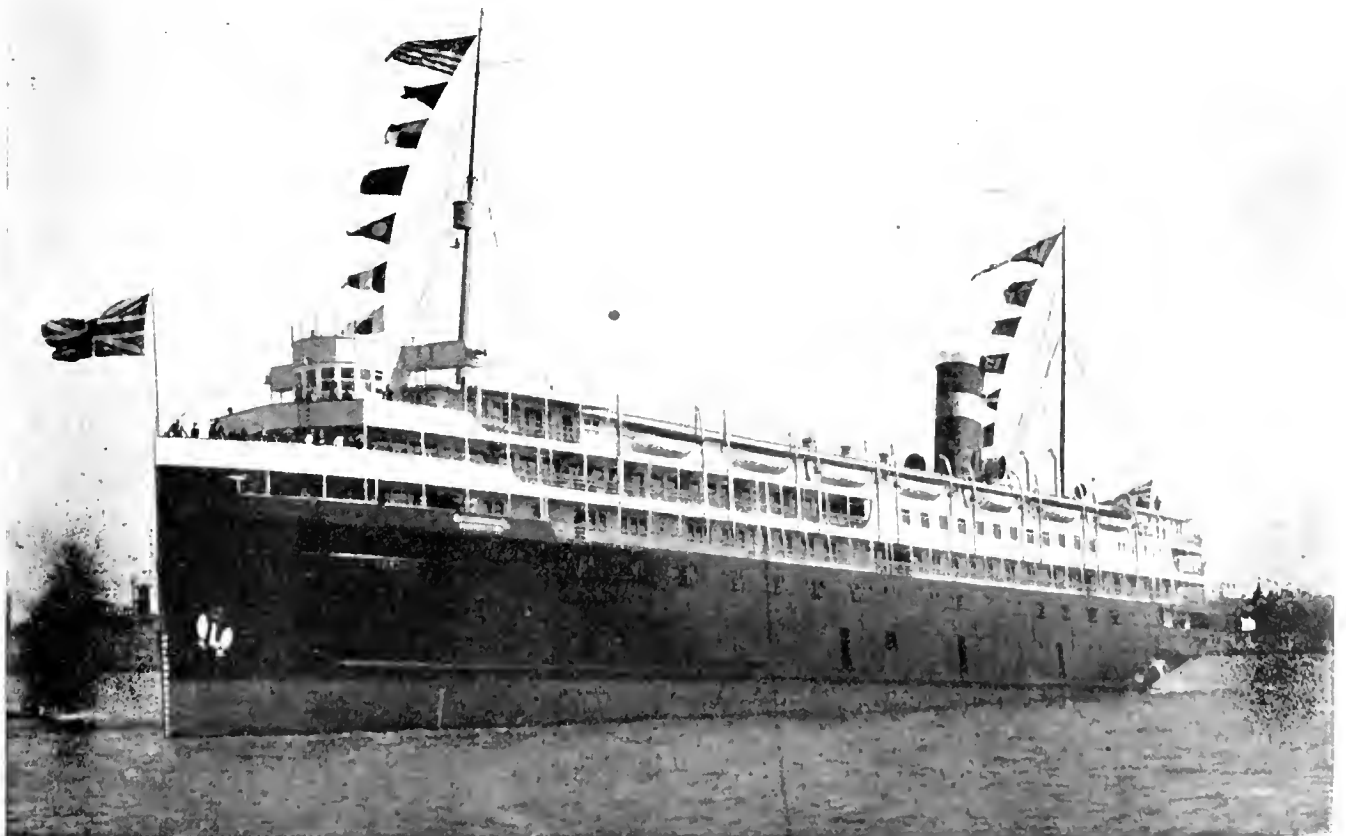

NORTHERN NAVIGATION CO. STEAMSHIP "NORONIC"— BUILDERS THE WESTERN DRYDOCK & SHIPBUILDING CO., PORT ARTHUR, ONT

preceding war months were highly abnormal to those of peace-time sea-borne traffic. The situation, in a word, is such as to give concern for the future, not altogether with respect to what may happen if the submarine menace be impossible of early complete control or subjugation, but jointly with, or separate as to these eventualities in the mat-

tain on the average to probably one per cent. of the whole and that wastage to that extent has been war-time operative. It is but reasonable to conclude that the reduction in world tonnage is even more serious than the figures already quoted.

of ocean carriers has reached an acute stage, and while Britain's shipbuilders are again "on the job," and can be counted on to demonstrate at least their old-time supremacy in tonnage output, irrespective of class or kind, there is room and opportunity for her Colonies and for neutrals as well with the plants and organizations to bear a capacity

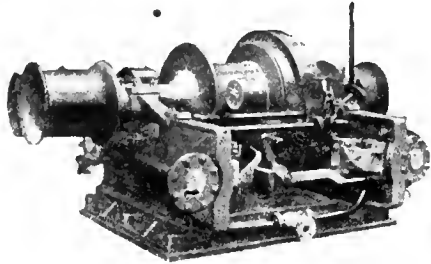

TYPICAL STEAM CARGO WINCH.

ter of the rehabilitation of the world's shipping tonnage, and more particularly that of British Empire Registry.

Shipping Losses Enormous

At the outbreak of hostilities, world shipping totalled some 50,000,000 tons, of which rather less than half, or, in round figures, 21,000,000 tons was British covered. As might be expected, out of the estimated total vessel losses up to February 1 of this year—2200 ships aggregating 41½ million tons, Great Britain has suffered most, her share being reckoned as little short of 23½ million tons. In view of the fact that peace time losses of ocean carriers at-

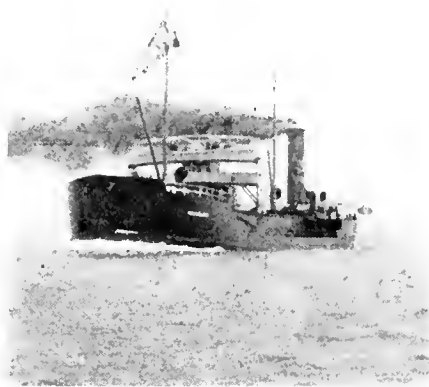

OIL TANKERS, "ROYALITE," "TOCOLITE," AND "SARNOLITE," BUILT BY THE COLLINGWOOD SHIPBUILDING CO., COLLINGWOOD, ONT.

It may be urged of course that, despite the widespread concentration on naval construction by British shipyards for quite an extended period, enough merchant vessel building was being undertaken to offset the "Act of God" losses; besides, neutral countries, and particularly the United States, had done much in that direction. Be this normal loss compensation as it may, the dearth

share in replacing the wastage, and incidentally in the case of the Colonies of aiding also in sweeping enemy marauders from the seas, and restoring the merited freedom of the latter as early as possible.

Our Call to Shipbuilding

To Canada then the call has come to participate in the restoration of the Empire Merchant Service, and, judging from the enthusiastic response already given, there is little doubt but that results will compare quite favorably with those achieved in the departments of men, money, and munitions. The work being undertaken has a twofold object—

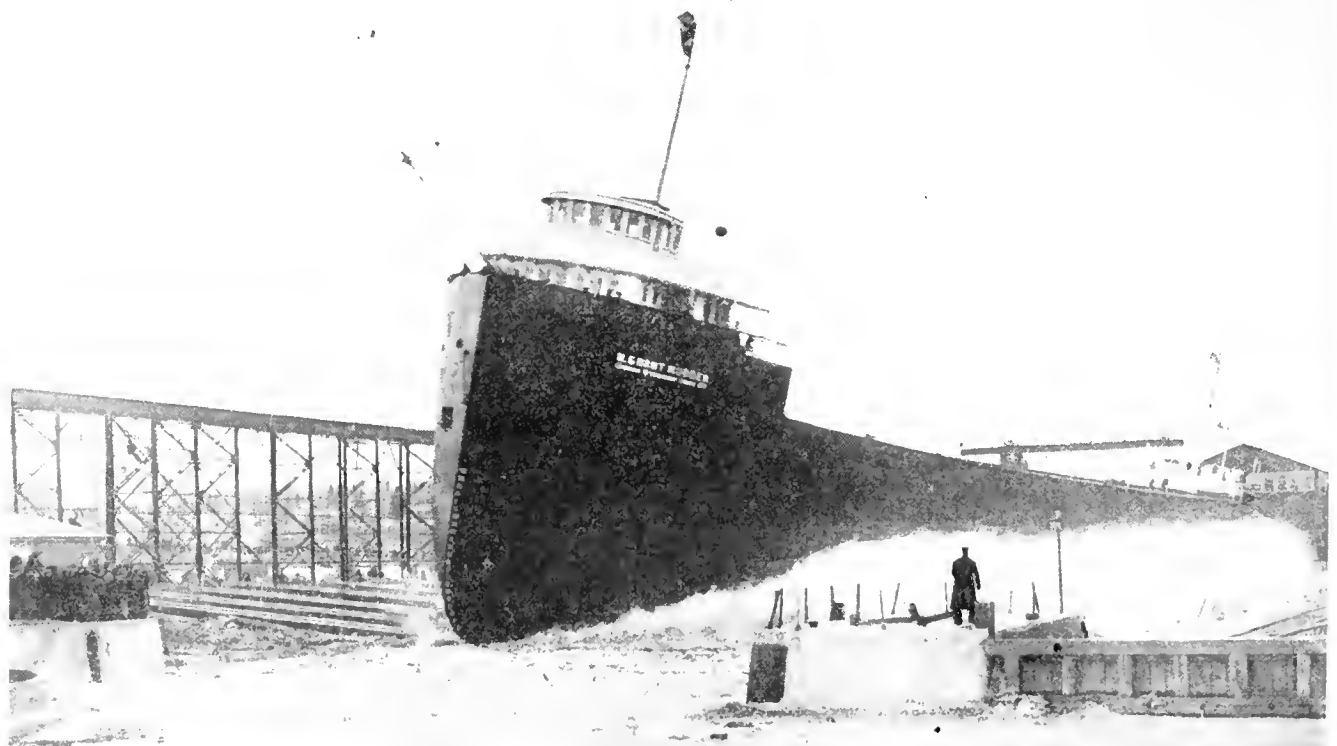

625-FT. FREIGHTER "W. GRANT MORDEN" BEING LAUNCHED FROM THE YARD OF THE WESTERN DRYDOCK & SHIPBUILDING CO., PORT ARTHUR, ONT.

the combating of enemy submarine activity and mine sowing effort, and the placing in service of a fleet of freighters to more or less standard design from keel to truck, and of carrying capacities commensurate with shipyard location and facilities. Notwithstanding the high cost of materials entering into vessel construction meantime—steel, finished and semi-finished, also the irksomeness of the steel mill situation as regards delivery, excellent progress is being made on hull, propelling machinery, and general outfit equipment, by those of our shipyards whose establishment and proved competency belongs to years

pondingly less severe, roofed-over sheds amply equipped with natural and artificial lighting facilities, lifting and

the unusual opportunity now offering, and thereby make a material contribution to their world-competitive status.

Making Shipbuilding a Staple Industry

The existing situation, and undoubtedly that of the coming years demand that Canada enter more largely into the business of shipbuilding. Preceding the war, the stumbling block to our development of the industry was, as already stated in connection with the shipbuilding berth matter, both the lack and uncertainty of demand for new construction, due wholly to European competition. From the loss figures previously

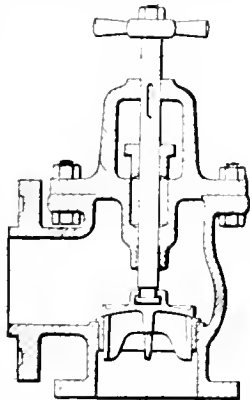

ANGLE TYPE CIRCULATING PUMP DISCHARGE VALVE

more or less well removed from the meantime emergency.

Our Past Accomplishment

To those unfamiliar with what has been accomplished by Canadian steel shipbuilding plants in previous years, the variety type vessel illustrations herewith may prove of rather more than passing interest, and when account is taken of the climatic and other disabilities under which those responsible for the administration of the various enterprises have labored in the past, considerable surprise may be manifested that so much both in quality and quantity, has been accomplished. The handicap of climate long and severe winters in the regions of our lakes, Eastern waterways and ocean shores, has not, however, been the most serious in restricting shipbuilding operations, although due to the hitherto fluctuating nature of the demand for new construction, and its general sparseness in volume for usage and individual vessel constituent, little effort has been made to reduce the climatic disability to the extent that building as well as fabricating operations could proceed uninterruptedly the year round.

Even in the Old Country, where the winters are less prolonged and corres-

pondingly less severe, roofed-over sheds amply equipped with natural and artificial lighting facilities, lifting and transportation conveniences are provided whereby the employees go about their work under conditions giving the maximum degree of both comfort and safety. There is of course the further gain, in that greater expedition is possible in the matter of output. To the writer's knowledge, only one Canadian shipyard, that of Canadian-Vickers, Montreal, has its shipbuilding berths shed-equipped, although we shall be much surprised if quite a large percentage of the new shipyards now being established, as well as the other meantime going concerns, do

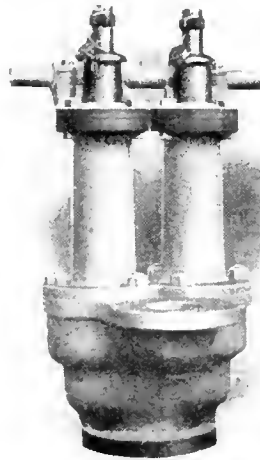

MARINE TYPE TWIN SAFETY VALVE.

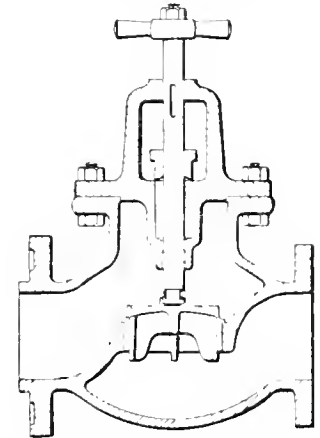

GLOBE TYPE CIRCULATING PUMP DISCHARGE VALVE.

quoted it will be readily apparent that the demand is now not only of extraordinary proportions but of the most imperative nature; and must needs be satisfied. While, therefore, no stone should be left unturned to make our entry one of urgent and immediate concern, let us see to it, that we do so with a due appreciation of the various factors operative in favor of or against positive success and substantial permanency.

Class of Labor an Essential

Class and cost of labor not necessarily that pertaining to shipbuilding only, have militated in considerable degree against our competitive ability in a world sense. Due to the intermittent vessel demand, however, it has been wholly impossible for our shipyards to maintain either an expert staff or more than a mere handful of mechanics trained to the work of shipbuilding. As a result, with little permanency of employment in shipbuilding, as well as its isolation from the ordinary work of the mill, the shipyard, more than any other

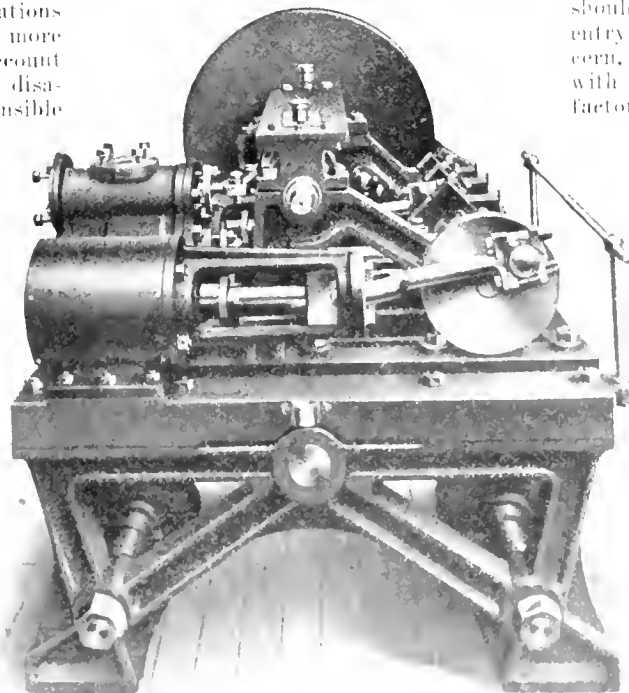

HORIZONTAL TYPE STEAM STEERING ENGINE.

not include in the foregoing of immediate future plans some such indispensable, and, so as to more effectively embrace

citizenship of its own nation, could not on occasions be expected to produce results commensurate with those of

their fellows on say the Clyde at Belfast, on the Tyne, Tees or Humber, in Great Britain, where employment in the various departments of shipcraft has been and is to all intents and purposes of a quite permanent nature. Under the latter circumstance the "bird of passage" tendency gives place to more or less permanence of residence. Again, even where we have in the past requisitioned unskilled local help, the practical training process has been largely unsatisfactory on account of lack of technical training facilities, and where these have been available, there has not infrequently been an insufficiency of elementary or day school education to enable the worker to appropriate the technical instruction offered. While, therefore, it will doubtless be possible to import, so to speak, not only a number of men skilled in directing shipbuilding operations in detail, and a fair muster

profession. To ensure success in this respect, among the other plans and projects being devised and developed, the plant executive, as is done in Great Britain, must arrange to provide instruction

the prospect of at least a handful of years of boom shipbuilding ahead, and a fair chance of the industry finding a permanent establishment, of scope hitherto unapproached, schemes for developing the quality of help should on no consideration be overlooked, be wilfully omitted, or be marked by indifference.

Cost of Labor

Aside from the cost of material entering into ship construction, no other factor has probably contributed to the lack of opportunity for vessel building in Canada so much as that of labor cost. For the like reason shipbuilding in the United States was in pre war days hopelessly outclassed as against European enterprise. Labor is a primary essential in every business worthy the name, and while its individual productive capacity may, as we have seen,

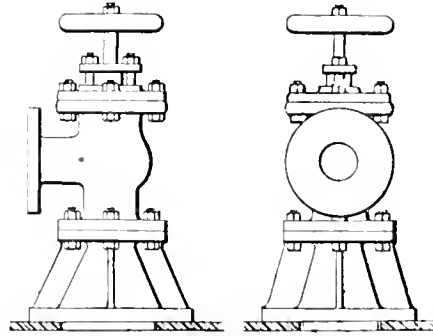

TYPICAL SEA SUCTION VALVE.

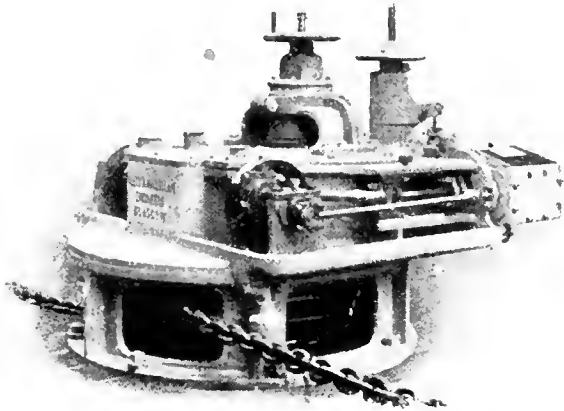

HORIZONTAL TYPE STEAM STEERING ENGINE.

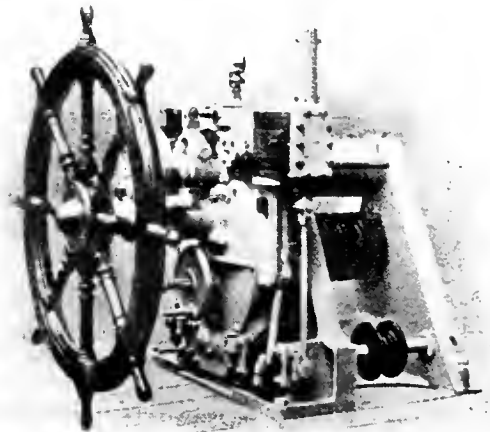

VERTICAL TYPE STEAM STEERING ENGINE.

of others with more or less experience of the everyday routine of vessel construction, it will be an absolute necessity, and more so as regards new enterprises that a service enlistment proposition be made our young men which will make it worth their while to enter shipbuilding and marine engineering—one branch or another, as a life craft or

courses, whereby what would otherwise indicate but a year-in and year-out monotonous routine leading to nowhere in particular, a lad's interest in his work and his ambition to rise to a place of prominence in his profession would receive the necessary stimulus. With

leave little scope for sifting out and replacement, it is well-known that its assessed value, which must often be accepted without demur, is in many instances altogether out of proportion to its output value, and of course in a direction quite foreign to the stimula-

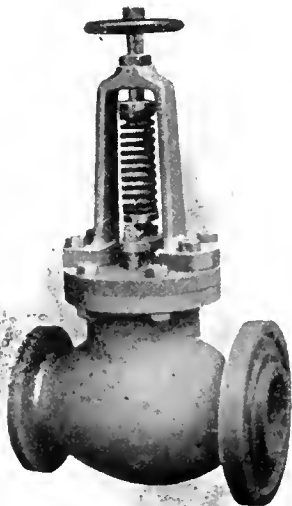

GLOBE TYPE AIR PUMP DISCHARGE VALVES.—ANGLE TYPE.



TYPICAL BOILER FEED PUMP.

tion of competition in the world's ship market. We will abstain from making direct comparison between shipyard employees wages in Britain and those in

formity in Great Britain and Canada now prevailing will be little disturbed when munitions and other forms of war effort cease. Suffice it perhaps to say

it is just possible that investigation even in a more or less superficial and general way of the more important considerations requiring attention may be of in-

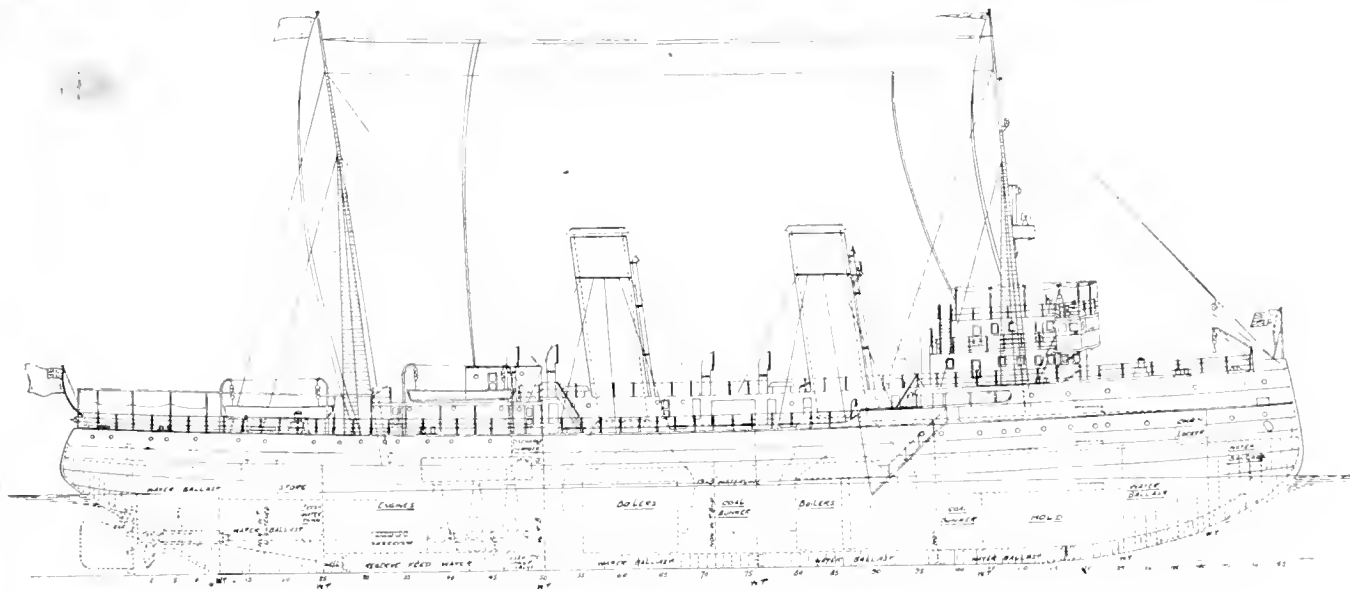

ICE-BREAKER "J. D. HAZEN," BUILT BY CANADIAN-VICKERS, LTD., MONTREAL.

Canada ante-dating the war, believing that no useful purpose would now be served if we did so, for the reason that

here, that previous to the opening of hostilities, the difference between wages paid in Great Britain and those in Canada was in itself sufficient to place Canadian shipbuilders well beyond the pale of being serious competitors in the world ship market. Labor quality and labor quantity will, it seems to writer, exert a more marked influence on the development, continuity, and permanence of Canada's shipbuilding industry during what may be termed its crucial or testing period, i.e. the next decade, than will any question of labor cost.

terest and profitable when studied from say a comparative viewpoint. On the assumption that labor costs are now to all

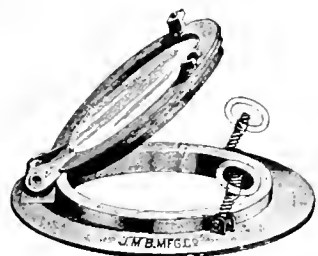

SHIP'S LIGHTS.

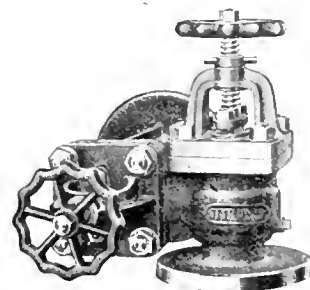

"BEAVER" COMBINED STOP AND CHECK VALVE.

a cleavage has taken place as a result of the varied war activities. It is our opinion that the degree of wage uni-

Material Cost

The question of cost of materials entering into shipbuilding and marine engineering has a many-sided aspect, and

intents and purposes equalized, and taking the cost of material pure and simple



IRON WORKERS SHED, CANADIAN VICKERS, LTD., MONTREAL.



CAULKING THE MAIN DECK OF 260 FT. O.A. AUXILIARY POWERED WOOD SCHOONERS.

as between Great Britain and Canada, what do we find? Materials of construction, whether for vessel hull, or miscellaneous equipment have been and still are for the most part imported by Canadian shipbuilders and marine engineers. Great Britain on the other hand is practically self-sufficient for her shipbuilding requirements, and in the light of her output capacity this is saying a great deal.

It has been urged that as in labor costs so in those of material, there is meantime, little, if any, difference in the price British shipbuilders are called upon to pay for, say steel, a circumstance due of course to the abnormal demand for that material for munition purposes as well as for shipbuilding, and to her having to supplement her domestic pro-

duction by import as in our case. It should, however, be borne in mind that the situation in Britain is not only highly abnormal these days, but of quite a temporary nature, and that so far as Canadian competition is concerned, the conditions we will have to meet when the demand for munitions steel, etc., ceases, will be approximately those of Britain's pre-war days, and with steel of her own manufacture. This, needless to say, will be more largely and readily available, because of the additional domestic productive capacity created by the war needs. A readjustment of steel prices favorable to British shipbuilders may reasonably be looked for following the cessation of hostilities.

Plant Locations in Canada

Of our present established group of



UNDER THE BILGE OF AN AUXILIARY POWERED WOOD SCHOONER.

tricts teeming with first essentials of shipbuilding. They are, however, more or less well situated for import of their requirements by water from the U. S.

Our lakes shipyards are handicapped when it comes to building even medium tonnage vessels for ocean service by reason of the insufficiency of canal accommodation via Montreal and the St. Lawrence to the sea, and while even now, on the upper lakes at least, freight and passenger ships of over 600 ft. in length have been built and are building, their service scope is restricted, with the result that the construction demand is quite intermittent. No limit as to vessel size is imposed on our Pacific Coast builders, yet the lack of proximity to the sources of supplies contributes to about the same ultimate outcome in progressive competi-



AUXILIARY POWERED SCHOONERS OF WOOD, 260 FT. OVER ALL LENGTH, BUILDING AT NORTH VANCOUVER, B.C.

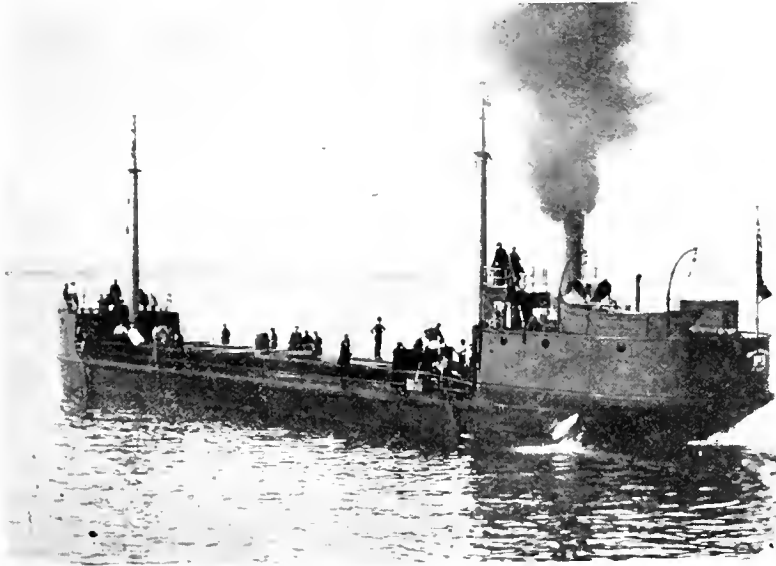

ONE OF THREE LIGHTERS BUILT BY POLSON IRON WORKS, TORONTO, FOR CANADIAN GOVERNMENT SERVICE ON HUDSON BAY.

tive development as does that of our lakes plants. In either case, however, the shipyards established are a necessity, if now solely for new construction, then for repairs and overhaul, and it may be accepted that the

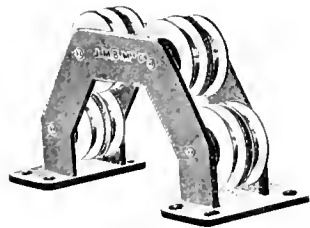

GUIDE SHEAVES FOR SHIP'S TELEGRAPHS.

plants at Toronto, Collingwood, Port Arthur and on the coast of British Columbia have been installed at strategic points, to undertake such work promptly and effectively. That they have been doing so profitably alike to themselves and vessel owner

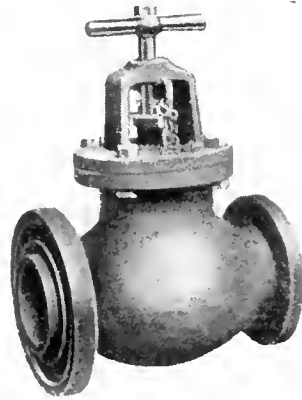

Globe Type.

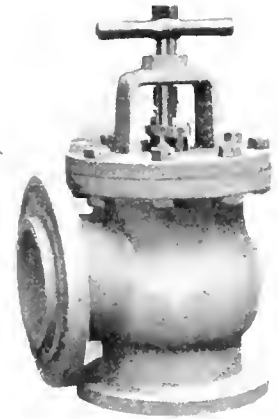

Angle Type.

CIRCULATING PUMP DISCHARGE VALVES.



BUCKET DREDGES BUILT FOR THE CANADIAN GOVERNMENT BY THE COLLINGWOOD SHIPBUILDING CO., COLLINGWOOD, ONT.

is well-known, and in the matter of building canal size craft—260 feet over-all length, they have exhibited commendable enterprise, and have been rewarded with well deserved success.

Plant Locations in Great Britain

In Britain, so far as rivers go, comparatively, there is nothing spectacular about the Clyde, Mersey, Tyne, Tees, Humber, etc. All of them are comparatively modest in length, navigable waterway, and otherwise attractiveness, yet they have appealed to shipbuilders, and have become famous on that account. Not one of them is a ghost, however, of its former self, and altogether to their specific location and possibilities have the sweeping changes and costly developments been attributable. Their location has given them importance because of their running through the heart of districts abounding with just such essentials of shipbuilding, engineering, and general manufacturing as part of their ready appropriation, reduction,

fabrication and transportation to world markets made and in the making.

If, then, the shipbuilding industry in Canada is to have competitive rank with that of Great Britain, it surely becomes absolutely necessary that she bestir herself and take care of her own business.

In the writer's opinion, the only way to do this is to have a shipbuilding plant in Canada, and that plant should be located in the Maritime Provinces. While it is true that the Maritime Provinces are not as well situated for the manufacture of iron and steel as the Lake Superior region, they are well situated for the manufacture of iron and steel for shipbuilding purposes.

The writer is of the opinion that the shipbuilding industry in Canada is to have competitive rank with that of Great Britain, it surely becomes absolutely necessary that she bestir herself and take care of her own business.

The writer is of the opinion that the shipbuilding industry in Canada is to have competitive rank with that of Great Britain, it surely becomes absolutely necessary that she bestir herself and take care of her own business. The writer is of the opinion that the shipbuilding industry in Canada is to have competitive rank with that of Great Britain, it surely becomes absolutely necessary that she bestir herself and take care of her own business.

ed to make a substantial and successful bid for vessel contracts against the world in the coming time.

The meantime centre of Canadian shipbuilding and marine engineering effort is the plant of Canadian-Vickers, Ltd., of Montreal, the volume and variety of work under construction there easily surpassing that being undertaken elsewhere in the Dominion. In addition, it has been constituted the distributing centre for numerous marine engineering contracts, the filling of which is being expeditiously carried out by well known Canadian engine and boiler builders over a comparatively wide area.

Shipbuilding Plants Projected

Since a full realization of the opportunities afforded us of taking a hand in the restoration of our Empire shipping has been grasped, many shipbuilding concerns have been incorporated, and not a few have already taken the preliminary steps of securing expert advice, and examining suitable sites. As bearing out what has been already indicated, it is noteworthy that without exception possibly, investigation is being made of locations on or adjacent to the Atlantic seaboard. Private enterprise, as might be expected, is being substantially backed and encouraged by a number of municipalities, prominent among which may be noted Three Rivers,

Que.; St. John, N.B.; Halifax, N.S., and Sydney, N.S. Provincial Government aid is not lacking either, for as recently

as March 23, a Bill, entitled "An Act for the Encouragement of Shipbuilding Within the Province," was intro-

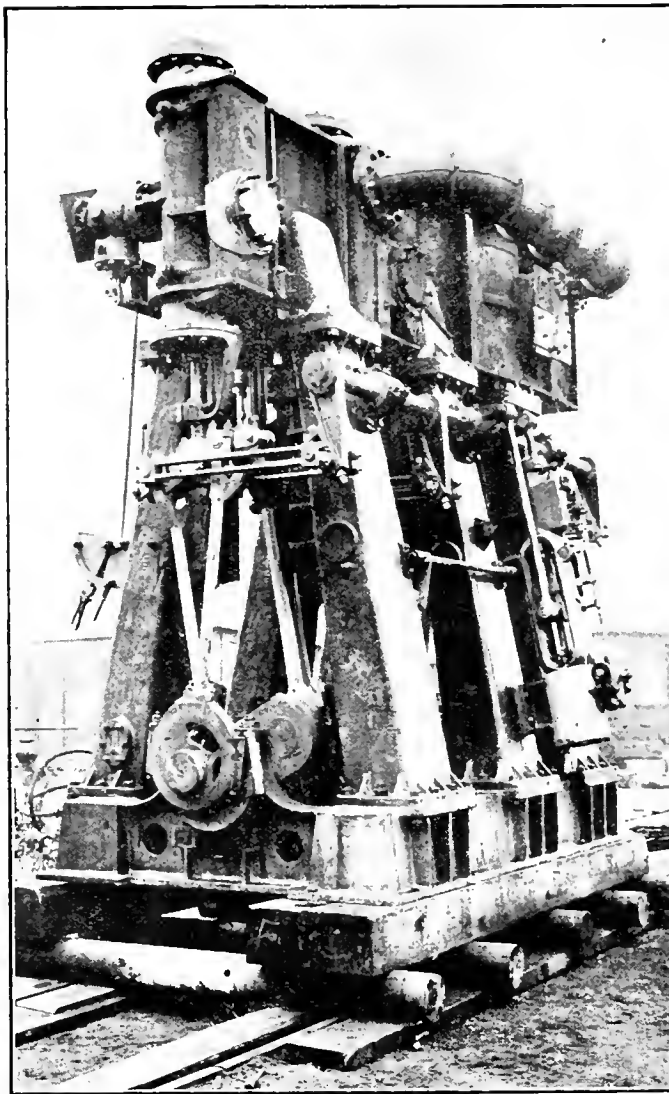

TRIPLE EXPANSION JET CONDENSING PROPELLING ENGINES OF 900 I.H.P. FOR CANADIAN GOVERNMENT BUOY STEAMER "GRENVILLE."

duced in the House of Assembly, Halifax, N.S., by Premier Murray. The Bill authorizes the appointment by the Governor-in-Council of a Commission, to be known as the Shipbuilding Commission, to consist of five commissioners and a secretary. The duties of the Commission are to investigate the facilities existing within the province for the building of ships and the manufacturing industries incidental thereto, and to make suggestions tending to the adoption of practical rules and regulations to encourage the utilization of all natural and other resources, calculated to facilitate the development of the shipbuilding industry within the province. The Commission is empowered to engage whatever technical or expert assistance is necessary.

The Bill provides that the Commission may, by Order of the Governor-in-Council, be created a body corporate, and when so created shall have power:—

To construct, purchase, lease or otherwise acquire ships and shares in ships, and to equip, maintain and operate any ships so acquired.

To establish, equip, maintain and operate any manufacturing plant for the manufacturing of ships of iron, or steel, or wood, or any combination of metals of like character.

To enter into any contracts with any company or corporation for the acquisition of any shipbuilding plant, and to acquire and exercise the power, rights, franchise and privileges, and assume the

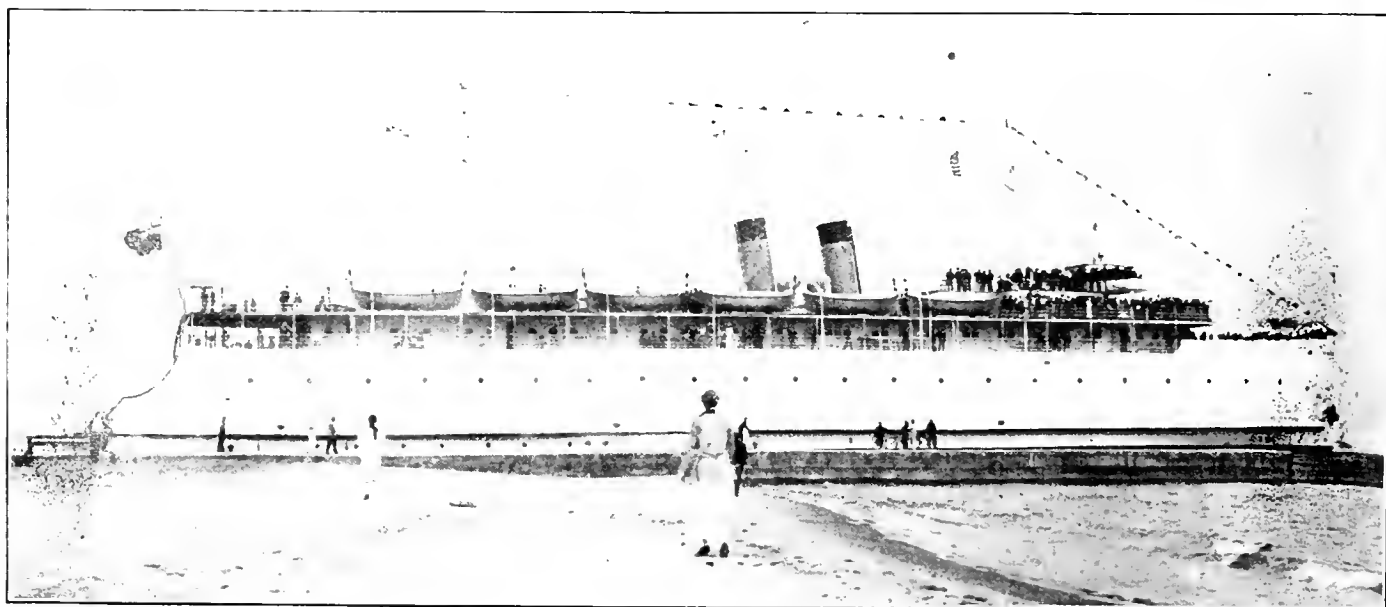

CAR FERRY "ONTARIO NO. 2," BUILT BY POLSON IRON WORKS, TORONTO.



ELECTRICALLY OPERATED GANTRY AND SHIP-BUILDING BERTH AT THOR IRON WORKS, TORONTO.

obligations of any company or corporation whose undertaking is purchased, leased or otherwise acquired by the commission.

To promote any company or companies for the purpose of acquiring all or any property of any company, or for any other purpose which may seem directly or indirectly calculated to assist

in the development of shipbuilding industries within the province.

To purchase, lease or otherwise acquire any real and personal property, and any right or privilege which the commission may think necessary or convenient.

A number of other objects and powers are enumerated. The Bill then provides the usual pro forma powers and autho-

riety, by the Governor-in-Council, to issue bonds, expropriate lands and to grant Crown Lands.

The Governor-in-Council is authorized to raise by loan on the credit of the province the sum of \$2,000,000, and the interest raised by the sale of Nova Scotia debentures or consolidated stock is to be paid into the Provincial Treasury and

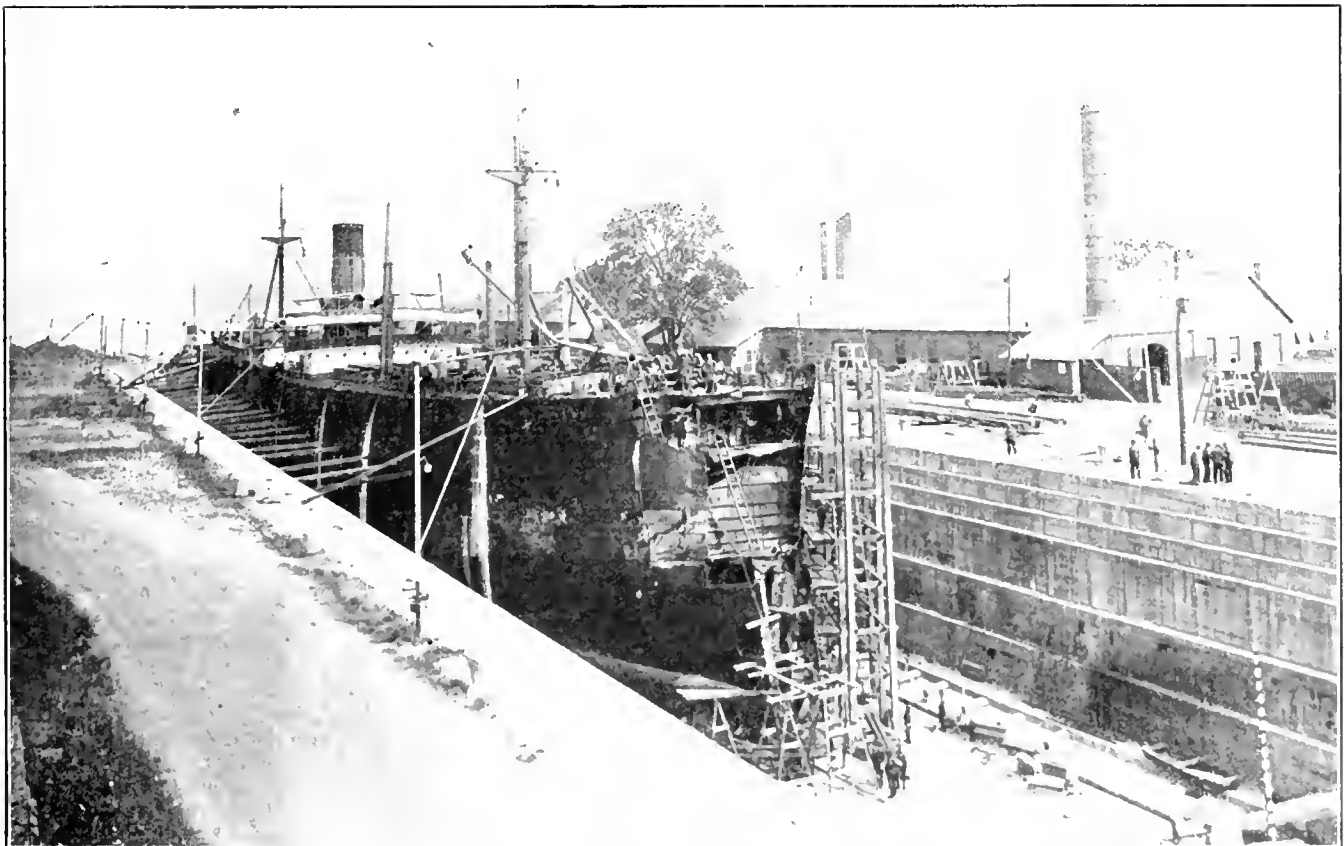

GRAVING DOCK AT LEVIS, QUE., WITH FREIGHTER UNDER REPAIR - DAVIE SHIPBUILDING & REPAIR CO



NORTHERN NAVIGATION CO. STEAMSHIP "HAMONIC" BUILT AT COLLINGWOOD, ONT.

used for the following variety purposes:

Payment of any expenses incurred by the Commission in the carrying out of the objects of the Act.



SHIP'S BELL.

Any subsidies granted by the Governor-in-Council to the Commission, or to any company engaged in the building, equipment or operation of ships.

Payment of obligations which the Commission may incur in the carrying out of its objects.

The Governor-in-Council is authorized to enter into any contract for the development of the shipbuilding industry in the province, and to grant subsidies to the Commission or any shipbuilding company within the province.

Shipbuilding Plant at Newcastle, N.B.

Within the last few days advices reached us that the International Shipbuilding Corporation, recently formed with a capital of \$2,000,000, had decided to locate a plant at Newcastle, N.B., the site determined upon having been that on which wooden ships were built when that feature of the industry flourished in the Maritime Provinces. In addition to a water frontage of some 1,600 feet, and a depth of water available to float ships of at least 10,000 tons, the town of Newcastle is admirably located for pro-

curring at reasonable cost the bulk of the lumber entering in ship construction and equipment. Not only so, within its borders and quite adjacent are several lumber mills, etc. The layout of the plant is in the hands of a naval architect of Boston, Mass., and among those interested in the undertaking are E. A. McCurdy and L. H. McNaught, of the town of Newcastle. The latter is managing director of the Maritime Foundry & Machine Works there, which enter-



"HUGGINSON" NON-TOPPLING BLOCKS FOR LIFEBOATS.

prise, it is understood, will be absorbed by the shipbuilding corporation.

Shipbuilding at New Glasgow, N.S.

As is well known, the Nova Scotia Steel & Coal Co., New Glasgow, N.S., in view of the shortage of "bottoms" a year ago, and the effect it was beginning to exert on the various steel producing activities at their Newfoundland, Sydney Mines, and New Glasgow plants, decided to try the experiment of building at least one vessel, the design, construction, and equipment features of which would meet the requirements of their own or that of any manner of freight-carrying service. Work on this ship, as also on her propelling and auxiliary ma-

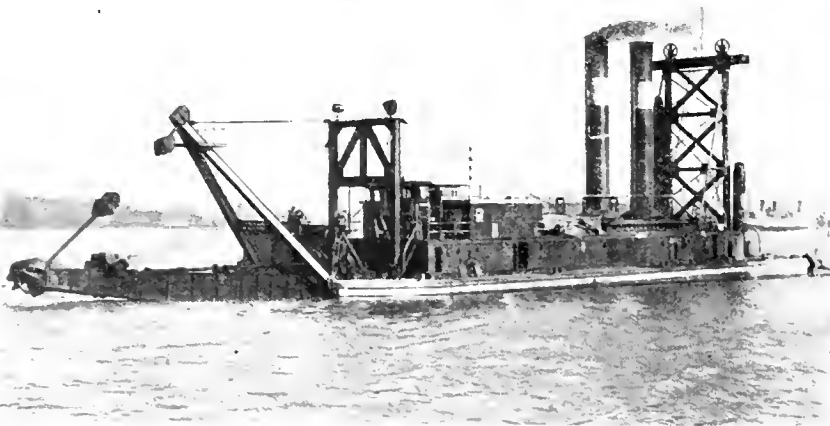

24 INCH HYDRAULIC SUCTION DREDGE BUILT BY POLSON IRON WORKS, TORONTO FOR HARBOR DEVELOPMENT WORK.

chinery, is now well advanced, and is being pushed forward with the utmost despatch, and her launch, which will be a red letter day, not only in the town of New Glasgow, but throughout the Maritime Provinces generally, is scheduled to take place on an early date. The building of this vessel is pioneer work in every sense of the term, as she will not only be the first steel ocean-going freighter to be constructed in our sea-coast provinces, but in the matter of her propelling machinery she will evidence a forward step so far as Canada is concerned in the sphere of marine engineering. In a word, she will be propelled by De Laval impulse type steam turbines of 1,000 B.H.P.

We were unfortunately unable to have an illustration of the vessel appear in this issue; however, from a perusal of the accompanying specification covering her principal features, some fair appreciation of the task that the management of "Scotia" set itself will be realized, and the more so when it is stated that the whole enterprise began at rock-bottom, so to speak—selecting, clearing, and preparing a building site.

The principal dimensions of the vessel are as follows:—Length over-all, 230 ft.; length between perpendiculars, 220 ft.; breadth molded, 35 ft.; depth mold-

ed, 20 ft.; load draft, 17 ft.; carrying capacity, 1,900 tons; displacement loaded, 2,870 tons; speed, 10 knots. The vessel is being built to Lloyd's 100 A1 class. She is of the single deck type,

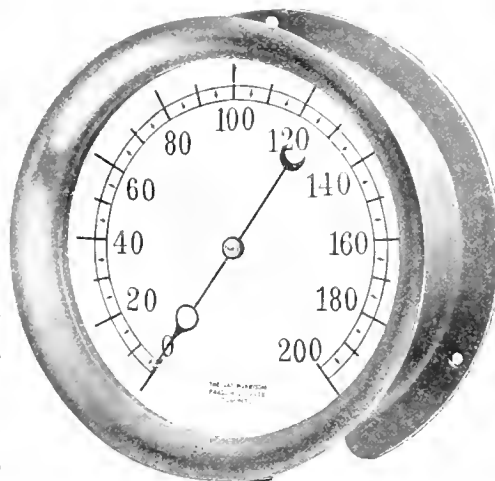

STEAM PRESSURE GAUGE.

with bridge and topgallant forecastle, the propelling machinery being placed amidships. The forecastle deck is 26 feet long, while the length of the bridge deck is 56 feet. She is provided with

complete double bottom, 34 inches deep, of the cellular type, constructed with solid and open floors, having centre division and two longitudinal girders on each side, running the entire length. The space between the bottoms is arranged for water ballast, so that a desired draft can be obtained when the ship is sailing without cargo.

Four water-tight bulkheads, extending to the main deck, divide the cargo holds, of which there are two, from the machinery space and peaks. The forward hold has two hatchways, each 28 ft. 9 in. long, by 19 ft. wide, one hatchway of the same dimensions being fitted to the after-hold. Two steel masts are fitted, each about 55 ft. high above the main deck, and for the handling of cargo the foremast will be provided with two derricks, while the mainmast will have one, each derrick having a lifting capacity of three tons. For this purpose deck winches of the latest type are being installed.

The frames are spaced 23 inches apart from the stern post to just abaft the collision bulkhead, where they are spaced 20 inches, and, to cope with ice conditions, the spacing in the forepeak is reduced to 17 inches, with heavy side plating at the load water line. This, together with panting beams and string-

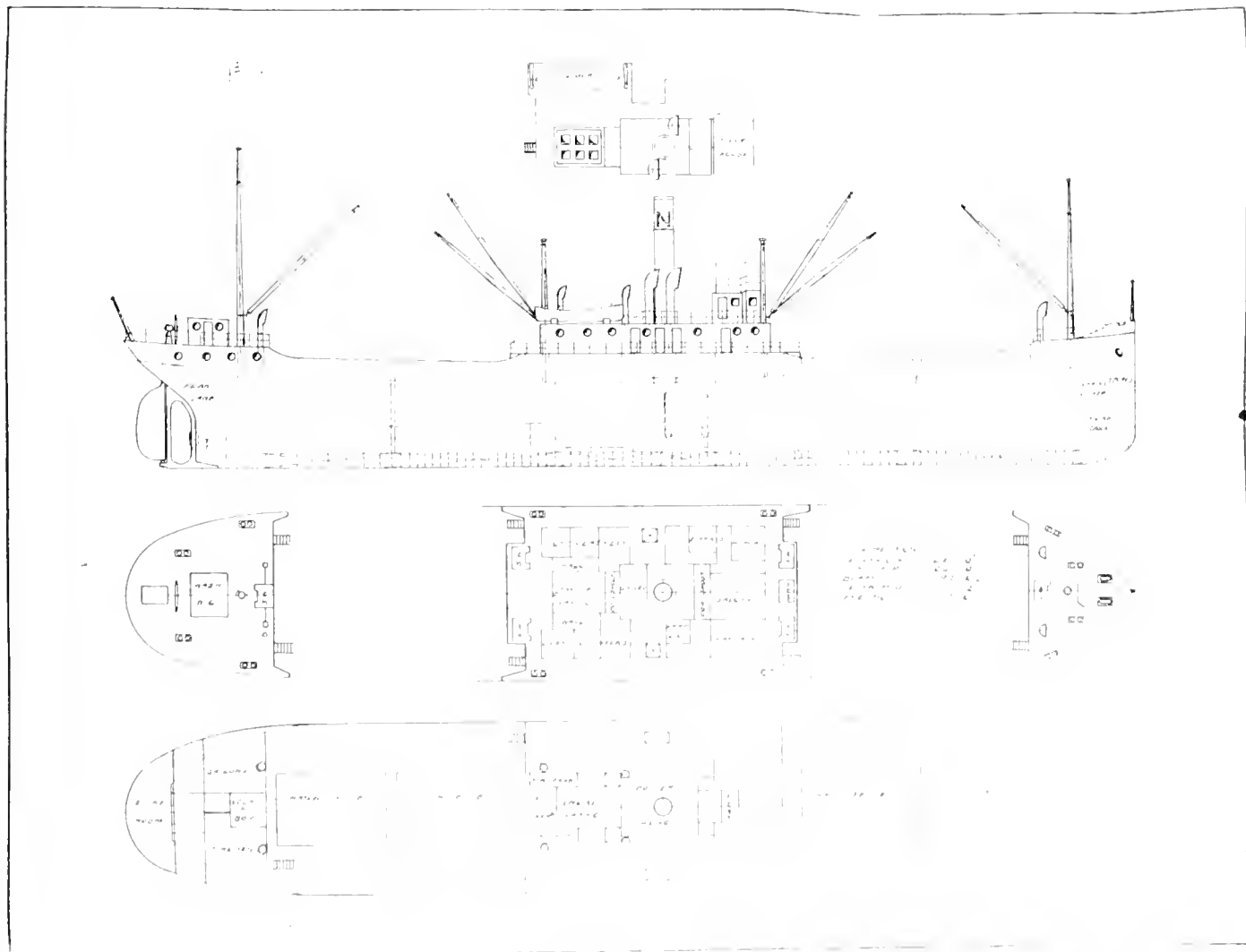

SINGLE SCREW STANDARD FREIGHTERS OF 2,500 TONS DEADWEIGHT BEING BUILT BY POLSON IRON WORKS TORONTO.

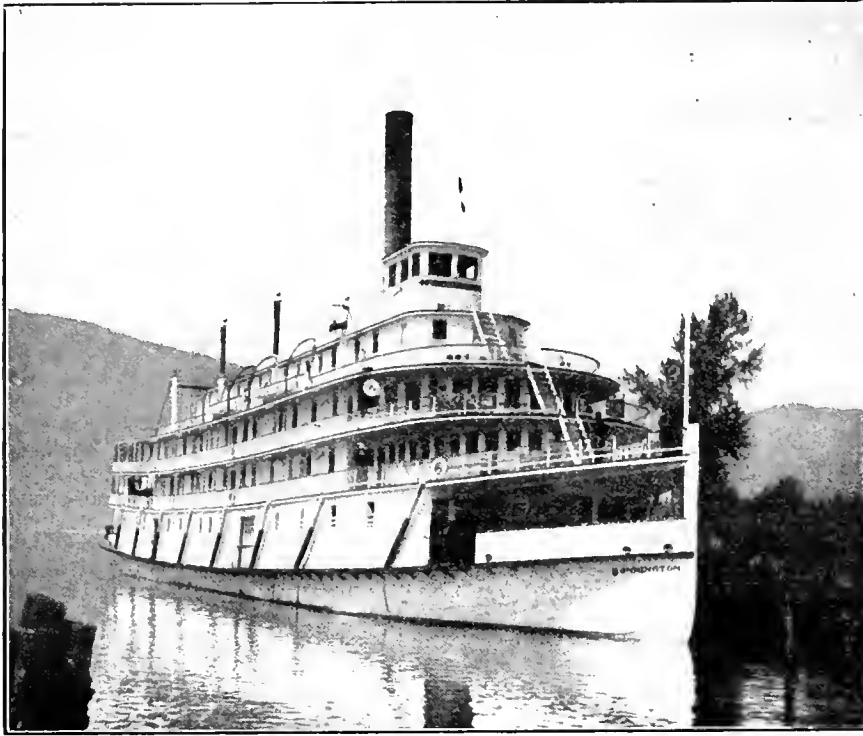

C.P.R. WESTERN LAKE STEAMER "BONNINGTON," BUILT BY POLSON IRON WORKS, TORONTO.

ers, makes the vessel exceptionally strong at the forward end. In the fore-hold, at a point between the two hatchways, a deep web and arch frame has been fitted 30 inches wide, with large brackets to the deck, thus eliminating stanchions and leaving the hold clear of obstructions.

At the fore end of the bridge is a deck house containing, on the bridge deck level, the captain's room, one spare room, steward's room, dining room, pantry, stores, and other offices. Above this is the chart room, pilot house, and

navigating bridge. Aft of the captain's quarters, the chief officer and chief engineer, together with the junior officers and engineers are housed, as is also the cook. Accommodation in the fore-castle is provided for five seamen and four firemen. Here also is located the crew's wash room, lamp room and dunnage room.

The propelling machinery is being supplied by the De Laval Steam Turbine Co., Trenton, N.J., and consists of an impulse type steam turbine capable of developing 1,000 b.h.p. when running at

a speed of 4,000 r.p.m. This is reduced to 80 r.p.m. at the propeller through two sets of reduction gears. The gears are lubricated with oil from a tank placed on the main deck. A separate pump is used to draw the oil from gear casings and deliver to this tank through a water cooler. There is also a separate pump to supply cooling water. Air and circulating pumps are driven by a separate engine capable of maintaining a vacuum of 28½ inches in the condenser with the engines developing full power. There is the usual installation of ballast, general purpose feed and bilge pumps.

Steam is furnished by two Scotch type marine boilers, each 11 ft. 6 in. in diameter and 11 ft. 6 in. long, their working pressure being 185 lbs. per sq. inch. The steam steering engine is placed on the main deck aft, with chain drum extending through the bridge bulkhead. The winches, three in number, are of the usual type, and have been designed and built by the Pietou Foundry & Machine Co., Pietou, N.S. The pro-

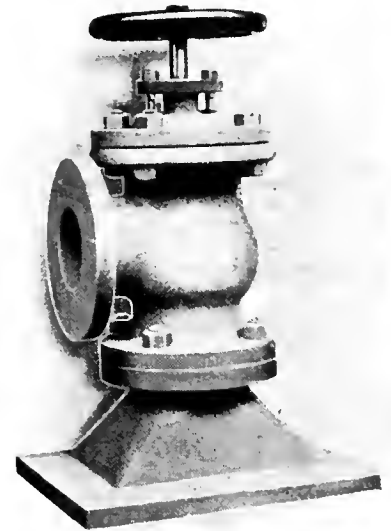

TYPICAL SEA SUCTION VALVE.

PELLING engines are the first of this type to be placed on any ship in Canada. They are also the first set of De Laval turbines to be placed on any ship, although since receiving the "Scotia" contract, the makers have secured orders for thirty of a similar type to be placed in vessels now building in the United States.

Shipbuilding in Wood

Enough has probably been said to indicate that the future development of the Canadian shipbuilding industry from a world competitive standpoint will be largely confined to our waterway and ocean shore territory from Montreal eastward. We do not, of course, lose sight of the fact that our inland lake and Pacific Coast shipyards will continue to contribute quite materially to our total annual outputs as they have done in the past, nor do we fail to recognize how essential they are for repairs, dockings, and overhauls, at such

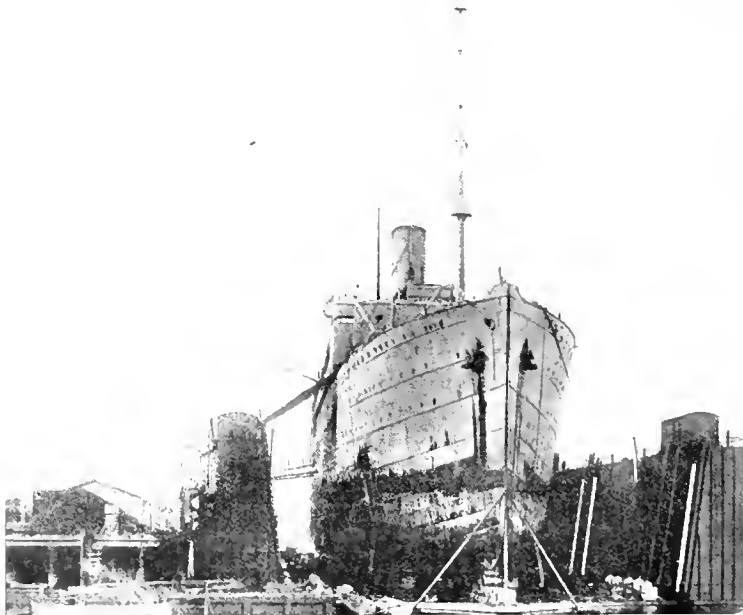

TYPICAL CANADIAN FLOATING DRY DOCK WITH VESSEL ABOARD.

sheltered and traffic strategical points as Toronto, Kingston, Collingwood, Port Dalhousie, Welland, Port Arthur, Vie-

already completed or approaching that stage. Shipyards on the Pacific Coast are admirably located for wood con-

struction. Wood shipbuilding, once our pride, has, in this war-created emer-

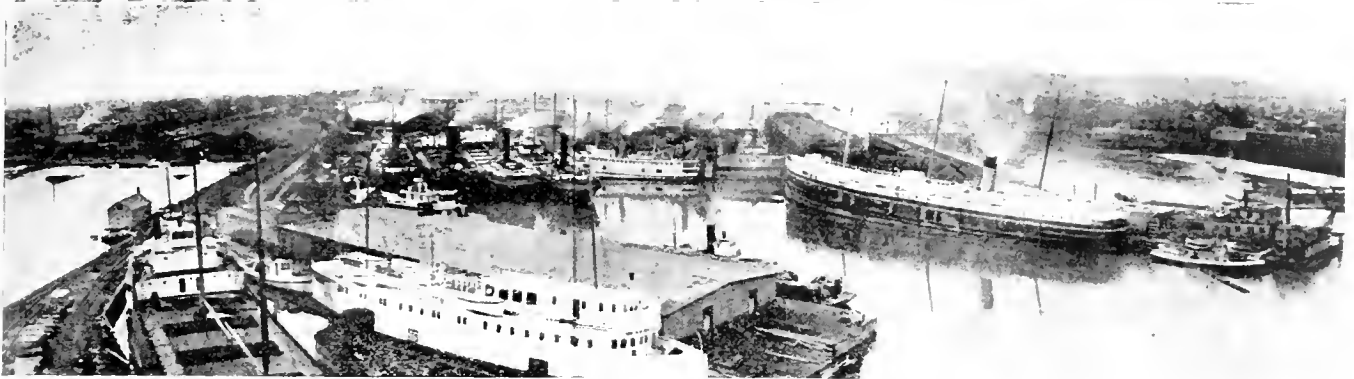

OFF-SHORE PANORAMIC VIEW OF COLLINGWOOD SHIPYARD, HARBOR AND TOWN.

toria, Vancouver, Esquimaux and Prince Rupert.

Shipbuilding is booming on our Pacific Coast, as perhaps never before in its

struction, lumber of every class and kind being abundant and readily convenient. Much enterprise has been shown in tackling this work of building

geny, been revived, and to an extent, little, if any, short of its most palmy days in our midst. It has temporarily stopped the gap caused by delayed new

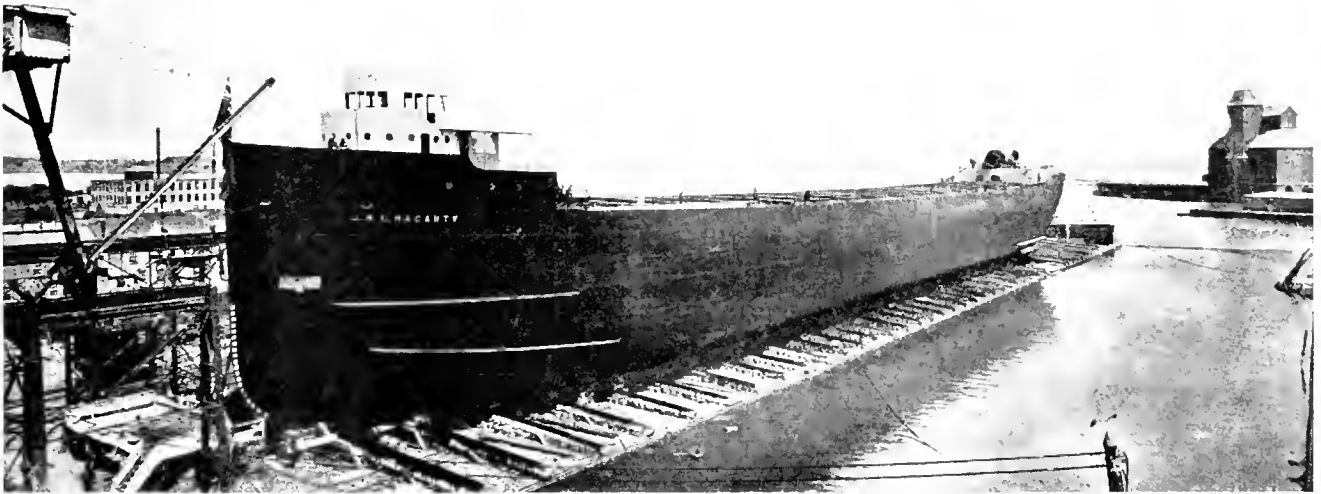

LAKE FREIGHTER "J. H. G. HAGARTY," READY FOR LAUNCHING AT COLLINGWOOD, ONT.

history, both wood and iron craft of hefty tonnages being under construction and not a few, particularly the auxiliary powered wooden schooner type, being

substantial ocean-going craft in wood, and the success of the effort not only on our Pacific shores, but on those of the broad Atlantic, is no less commendable

construction in steel, through the abnormal demand for that commodity for other purposes, etc. Ton for ton, wood construction is cheaper, and while, dur-

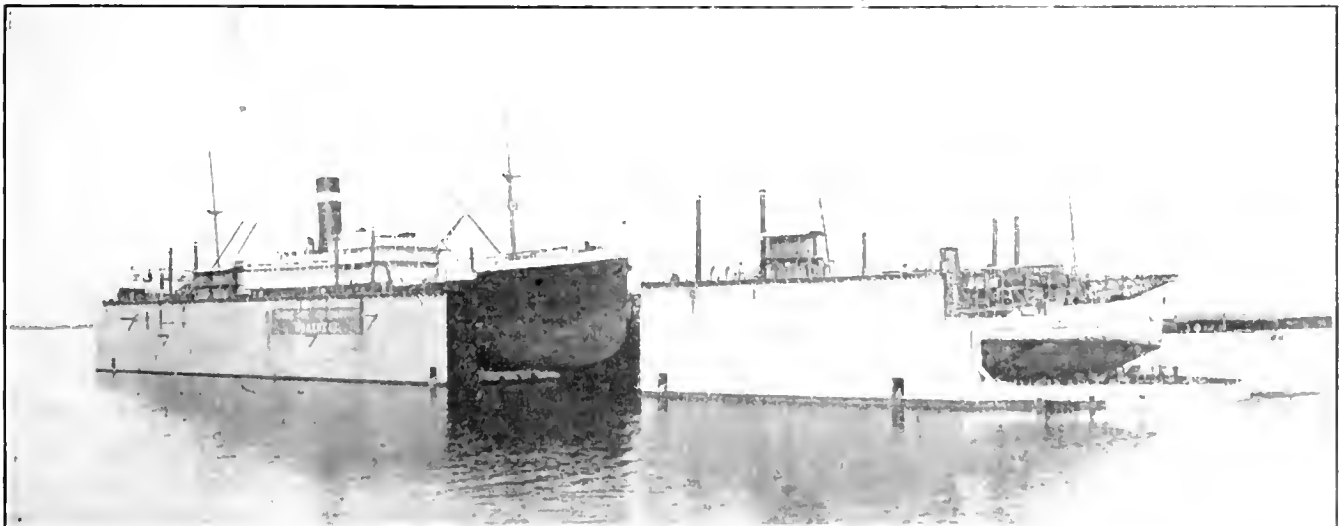

TYPICAL CANADIAN FLOATING DRYDOCK WITH TWO SECTIONS OPERATING INDEPENDENTLY

ing the course of the war, with the continued activity of enemy submarines and the risks of colliding with mines, wooden craft are no doubt more vulnerable, the

fact remains that their cost as compared with steel vessels, is less burdensome should disaster supervene. Chief among the Pacific Coast firms building wooden

craft on a large scale are the Cameron Genoa Mills Shipbuilders, Victoria, the Wallace Shipyards, North Vancouver, and John Coughlan & Sons, Vancouver.

ENGINE DRIVEN CENTRIFUGAL CIRCULATING PUMP MANUFACTURED BY SMART-TURNER MACHINE CO., HAMILTON, ONT.

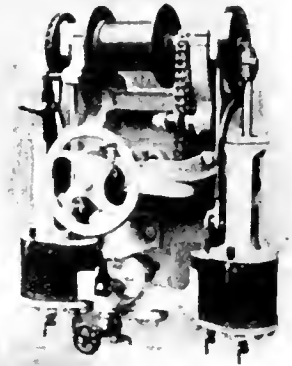
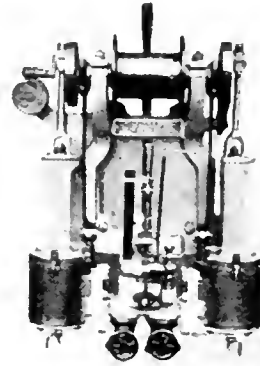
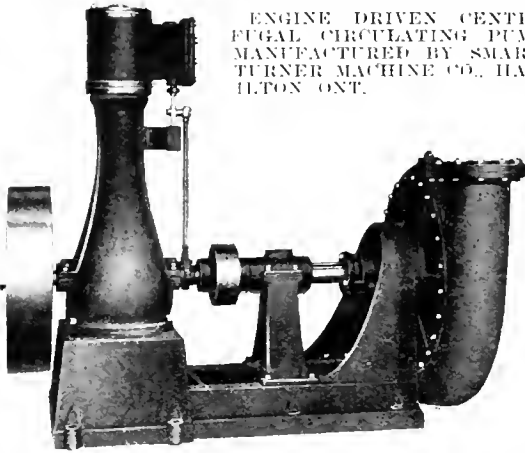

SINGLE CYLINDER, VERTICAL ENCLOSED SHIP LIGHTING SET, MANUFACTURED BY GOLDIE & McCULLOCH, GALT, ONT.

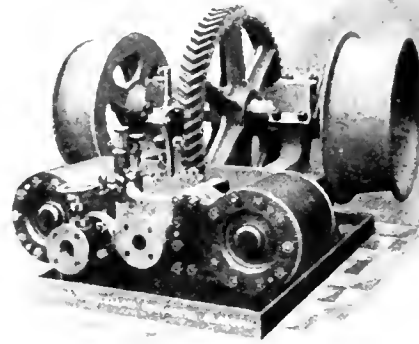
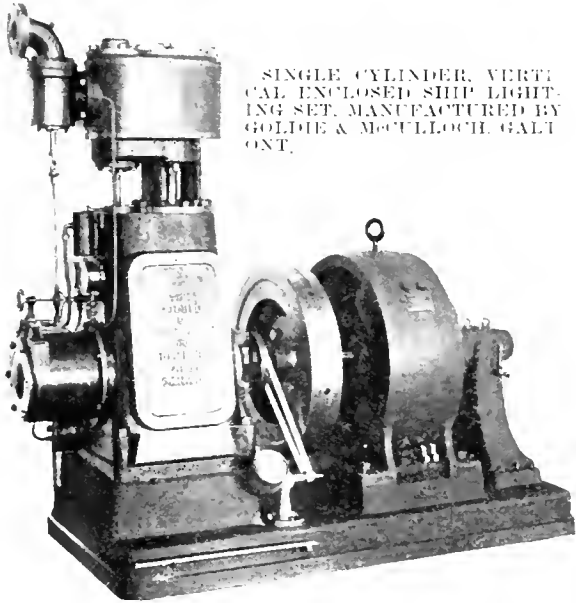

ASH AND COAL HOISTING WINCHES ABOARD SHIP.

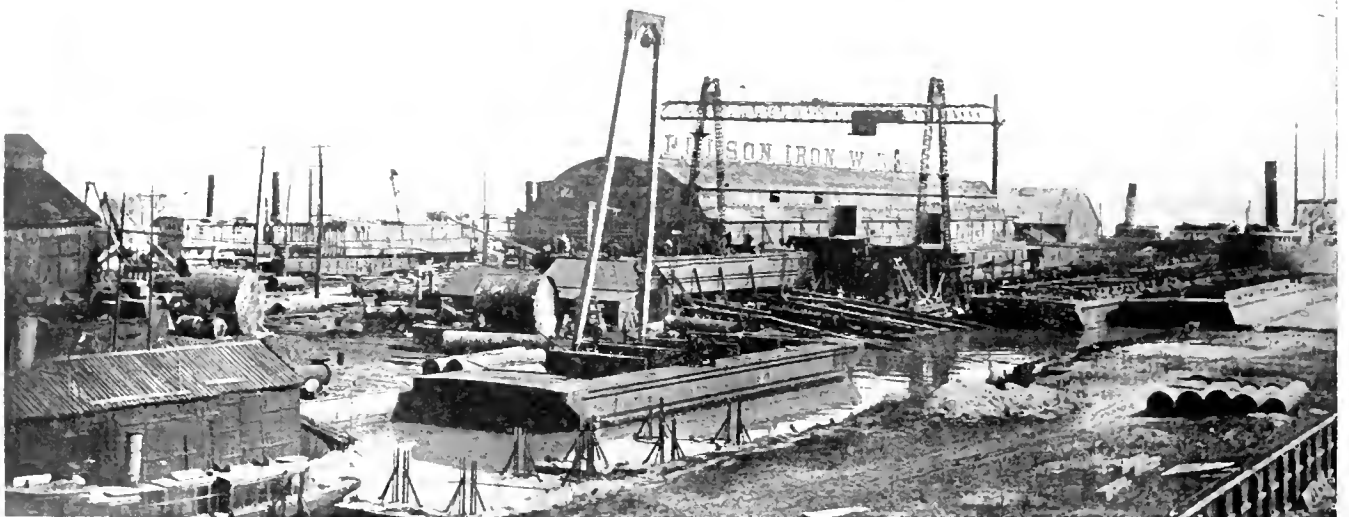

GENERAL VIEW OF SHIPBUILDING PLANT OF THE POLSON IRON WORKS AT TORONTO, ONT.

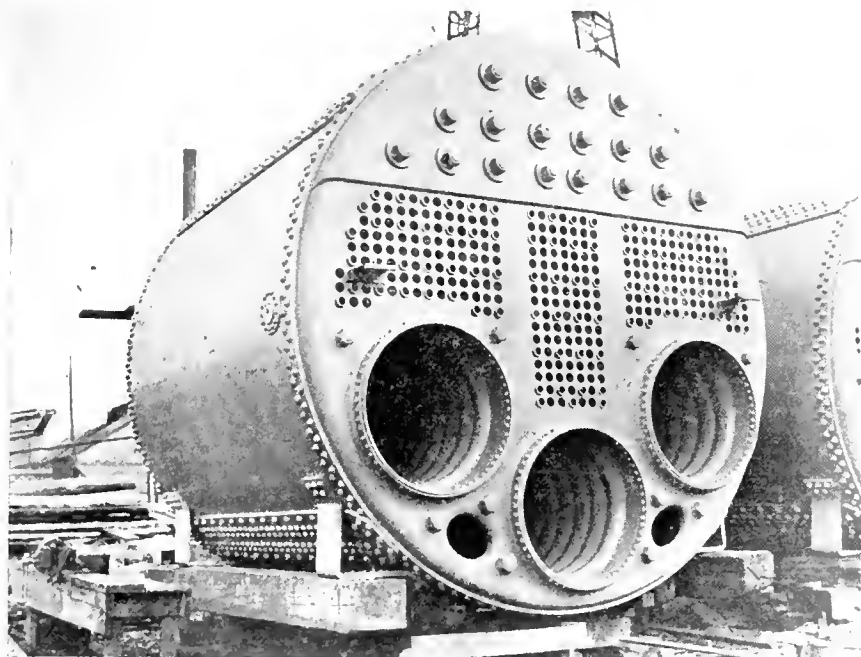

SINGLE-ENDED BOILERS FOR CAR FERRY "ONTARIO NO. 2" EACH 14 FT. DIA. BY 12 FT. LONG. WORKING PRESSURE 180 LBS. PER SQ. INCH. MORRISON SUSPENSION FURNACES 12 IN. INSIDE DIAMETER

Shipbuilding Industry Auxiliaries

Shipbuilding, when the construction of high-class liners is involved, may be said to be altogether cosmopolitan, in that hardly any trade or industry may be found unassociated with it. In degree only is this less true of craft with more modest titles—tramps. Among the illustrations accompanying this article, will be found a fair representation of accessory equipment common to deep sea vessels, whether for salt or fresh water service, passenger or freight trade. The examples of vessel type—there is no lack of variety, are in every case products of Canadian shipyards, and with a few exceptions the auxiliary machinery and accessory equipment are also of Canadian manufacture. The excep-

tions, we may say, are representative of British manufacture, some of which have in the past found a place aboard Dominion-built ships.

As bearing out the statement in the opening sentence of the above paragraph, shipbuilding may be said to create opportunity and broaden the scope of metal working and kindred manufacturing plants, irrespective of their being large or small. A few of the requirements follow:—Brass, iron and steel castings; ship and engine forgings, heavy and light; deck and hold stanchions; ship plate and shape mills; sheet iron and tinsplate work; chain anchor and derrick; rope—hemp, Manila, wire, for mooring and hoisting; anchors, lamps, radiators, wash basins, bath tubs, water closets, furniture and furnishings; lifeboats, lifebelts, lifebuoys, electric wiring, charts, compasses and telegraphs; hand and steam steering gears; steam and hand winches, windlasses and capstans; ash hoisting engines and ash buckets, firing tools, chequered plating, sparrd gratings or grills, and hand railing; safety, stop, and throttle valves; feed check, sea suction and discharge

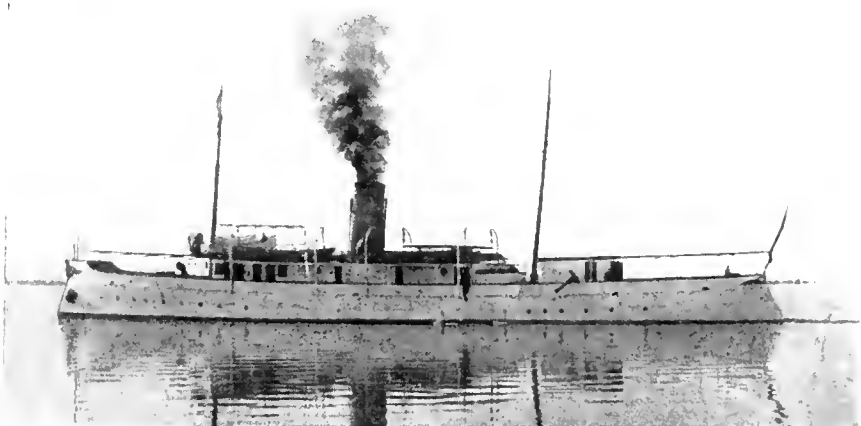

CANADIAN GOVERNMENT FISHERIES PATROL BOAT "VIGILANT" 156 FT. x 22 FT. x 14 FT. 3 INS. BUILT BY POLSON IRON WORKS.

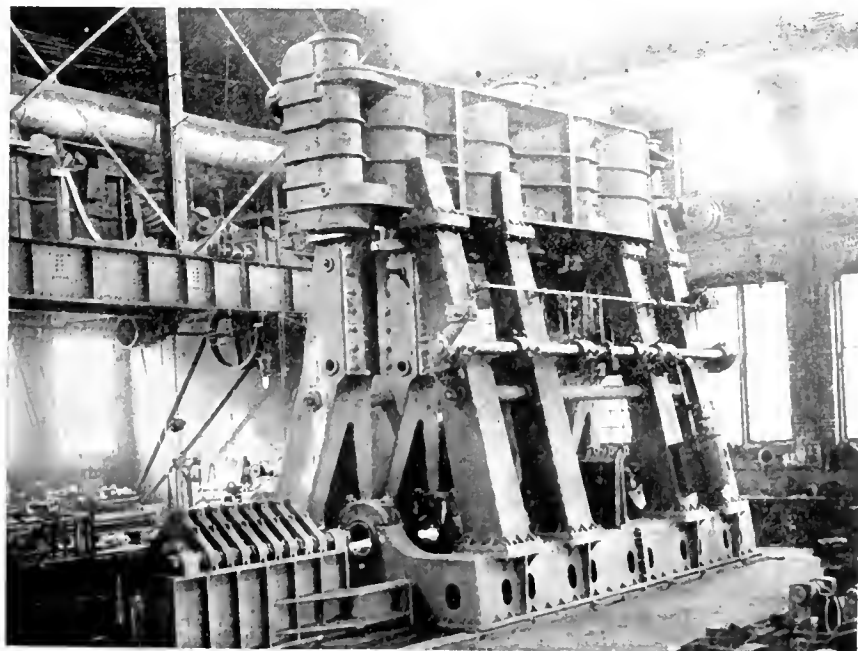

TRIPLE EXPANSION ENGINES OF THE NORTHERN NAVIGATION CO. S.S. "HARMONIC" BUILDERS THE COLLINGWOOD SHIPBUILDING CO.

valves; water gauge fittings, pressure and vacuum gauges, jointing material and gaskets; boiler, pipe, and cylinder lagging; directing or distributing boxes; feed, bilge, fire and deck pumps; propellers; shaft, centre, piston and connecting rod forgings; cylinder drain and small pet cocks; relief valves; dynamo engines and dynamos; motors; forced draft and ventilating fans and engines; oilers; chain blocks; rope blocks, copper and brass piping; indicators, indicator cocks and piping; eyebolts, shackles, clocks, galley and refrigeration equipment, ship chandlery, general, etc.

Convenience in procuring equipment as above detailed is by no means unimportant, although in the establishment of new shipbuilding plants it is not always possible to have the various trades represented within ready call. Judging from personal observation, and having the various auxiliaries and accessories enumerated in mind, such centres as Montreal, Que.; Halifax, N.S., and St. John, N.B., would be ideal for a shipbuilding and marine engineering plant installation, other conditions being



GENERAL VIEW OF PLANT OF THE MONTREAL DRYDOCK CO.

by, just as well, and oftentimes more promptly than they themselves could, through lack of reasonable opportunities; the cost besides is usually less. A "way-out" from munitions making may be said to be now offering to many of our smaller machine shops and foundries, by their seeking to supplement in the lesser details, the big underlakings of our shipbuilders, and if the same keenness to get the business, and expert application is directed to its subsequent handling, as were apparent in shell manufacture, there is little doubt but that equally satisfactory returns will follow.

It has been endeavored in the foregoing to present such data as meantime may draw attention to Canada's capacity and readiness to bear a part in the restoration of her Empire shipping status.

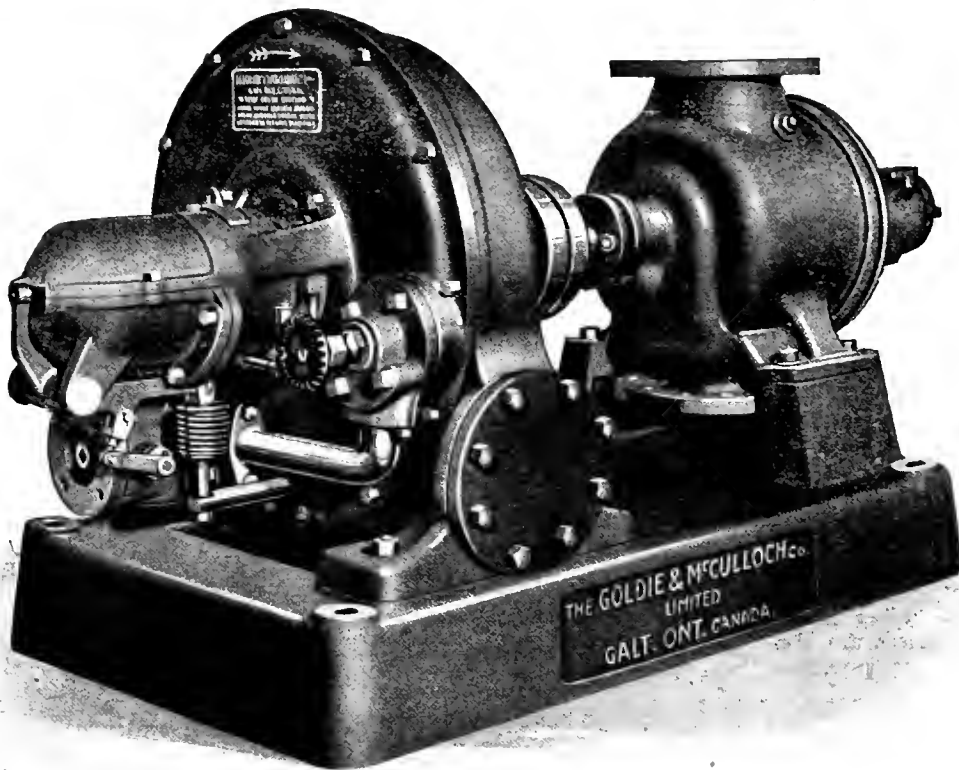

TURBINE DRIVEN CENTRIFUGAL PUMP FOR BILGE, BALLAST OR CIRCULATING PURPOSES.

equally satisfactory, of course. In each of these cities, small engineering, blacksmithing, and foundry enterprises abound, as do also agents with warehouse accommodation for stocking standard marine supplies. A shipyard unless surrounded by quite a coterie of general providers as indicated is both isolated and handicapped, and while such a condition may be altogether beyond control, an obstacle of no mean proportions is always in evidence to restrict progress and expansion, no matter how ideal be the water front facilities.

Shipbuilders and marine engineers welcome the help arising from the outside sources enumerated, enabling as it does their concentrating on the main essentials of their various contracts, and relieving them of the necessity of doing work which can be done in a plant near-

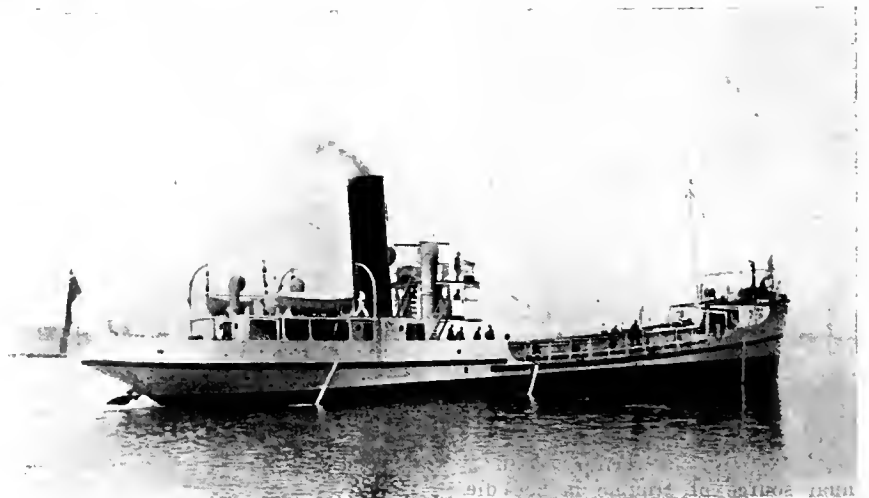

CANADIAN GOVERNMENT HOPPER BARGE NO. 2, BUILT AT COLLINGWOOD, ONT.

PRODUCTION METHODS AND DEVICES

A Department for the Interchange and Distribution of Shop and Office Data and Ideas Evolved from Actual Practical Application and Experience

MAKING EXPANSION TAPS

By D. A. Baker

HAVING experienced considerable difficulty in tapping the base plug thread in the type 80 and 85 time fuse the tap described was designed and successfully used. Solid taps were difficult to make that would give us a thread which would gauge properly, and then difference in the metal, or wearing away of the tap gave very indifferent results and so an expansion tap seemed to be the only solution.

The sketch herewith shows the construction, A being the body of the tap, and B the expansion screw, while C, C, are four narrow slots milled into the body of the tap and carried back a short distance behind the threaded portion. The hole in the body of the tap for taking the expansion bolt was threaded for only about three-quarters of an inch from the back end, while the thread on the bolt was about twice as long. The clearance hole for the expansion bolt was made straight up to the front end, where it was slightly rounded over where the taper on the bolt came in contact with it. When grinding the face of the tap back of this part this corner should be kept rounded over with an oil stone so as not to bite into the taper.

In hardening this style of tap we found best results could be obtained by making up a soft steel nut which would

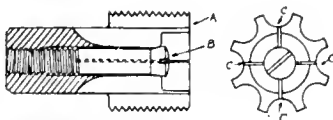

EXPANSION TAP.

just fit the tap, then dipping this and also the expansion screw into a mixture of graphite and oil, the nut, tap and the expansion screw were assembled, and in that condition put into the furnace. In this way the nut and the expansion screw held the tap from distorting, while the graphite and oil were to prevent the parts from sticking after having been through the fire. Taps were afterwards drawn to a blue except on cutting edges. These were drawn to a dark straw.

WATER-COOLED PIN FOR NOSING DIE

By H. P. Hoag.

IN the course of manufacturing 4.5 mark VII shells, the writer found a continual source of trouble in the die pin which enters the nose of the shell and is subject to very severe wear, in-

volving its renewal every day. The advantage of using water-cooling for the die was so marked that arrangements were made for water-cooling the pin also. The arrangement was as shown in the accompanying illustration. The dowel for centering the die-holder in press was drilled out, and a 1/8-in. pipe attached, which extended down into the

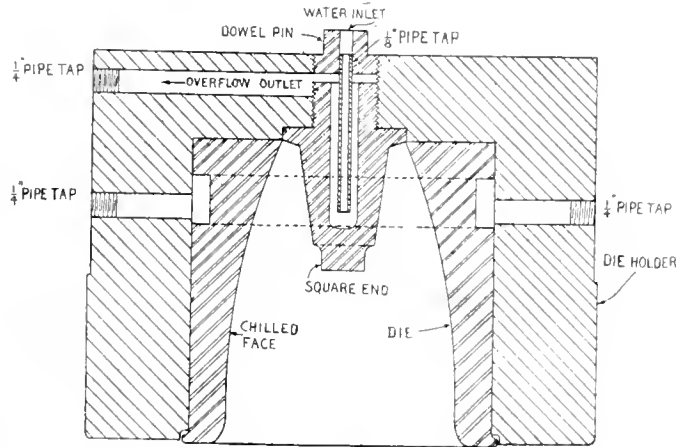

SHELL-NOSING DIE WITH WATER-COOLED PIN

pin, the hole in the pin being large enough to leave a space all around the 1/8-in. pipe. It will also be noticed that the threaded portion of the dowel is short enough to leave an opening between it and the die-pin.

The action is as follows: Water is introduced down through a hole in the press to the hollow dowel into the die-pin, and is forced up along the inner wall and out over the end of the die-pin, thence through the side opening, as shown. The die is also shown with water-cooling arrangement. Die-pins cooled by such an arrangement as described have as long a life as the die itself, no matter how hard the press is worked.

SPECIAL HEAVY COLLET CHUCK

By R. Hamilton.

THE chucking of the larger shells, when performing operations on the interior, is one of the factors in the manufacture of munitions that has been given a great deal of thought and attention, and it is probably this feature, as much as any other, that has caused such radical de-

partures in the design of special machines for the unit operation system. Before the advent of the self-contained chuck in the headstock of the lathe, it was necessary to attach a separate chucking device, together with a steady rest, in order to accomplish the desired purpose. The construction of these chucks is so varied that seldom will two plants be found with identical fixtures; the execu-

tives of each individual shop having developed their own particular design from past experience and existing available equipment. The general design of the spindle on the ordinary standard lathe does not permit of attaching these special chucks direct to the nose of the spindle; the practice being to secure the device to the face-plate of the lathe, or one that is specially provided for the purpose. The accompanying cut, however, shows one of these fixtures bolted direct to the spindle, and while in some respects it has a cumbersome appearance, it has proved highly satisfactory and efficient.

The main casing of the chuck is a

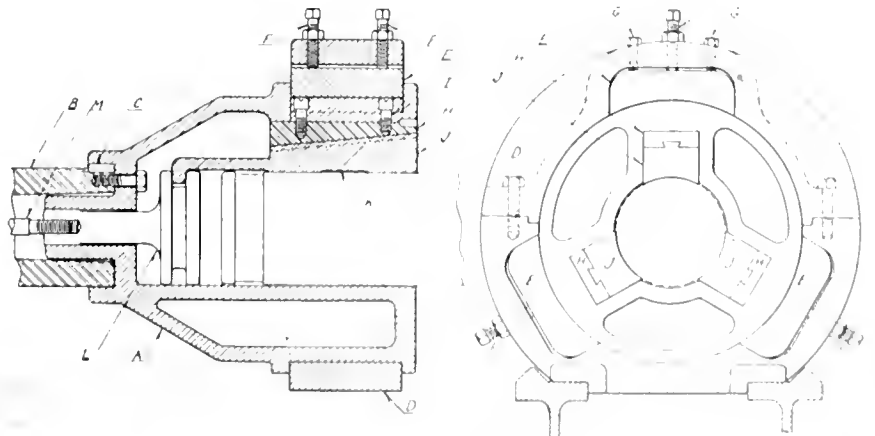

SPECIAL HEAVY COLLET CHUCK.

large casting cored out as shown in order to provide lightness with size. The casing A is secured direct to the nose of the spindle and locked in a permanent position by means of the key C, the outer end of the chuck body being supported by the steady rest D. This steady head is made in two halves, the lower section being fitted and secured to the ways of the lathe. Three slots are machined in the steady rest D, and fitted with the blocks E, these having a bearing surface of approximately 72 square inches each. The bearing blocks are adjustable by means of the screws F, the top block being fitted with retaining bolts G in order to prevent its falling out when the steady rest is free from the chuck. At three equi-distant points in the chuck casing, parallel slots, 4 inches wide, are machined to carry the operating mechanism. Secured to the bottom surface of each slot is the tapered block H, held in position by two fillister head screws I. The gripping jaws J are dovetailed to the blocks H, so that no springs are necessary to free the jaws from the shells after the pressure has been removed, the action being positive by the angle of the dove-tailed slide. With the exception of the relieved portion K, each jaw has a bearing 10 inches long and 4 inches wide on the surface of the shell. The outer end of the connecting piece L is a grooved collar that engages the tail of the three gripping jaws. The rod M connected the piece L with the operating cylinder placed at the outer end of the lathe spindle.

ing a reducer of the volume of lead, it was a reducer of oxidation by leaving the smaller area of lead exposed to the air. In a few weeks the iron had paid for itself and was showing a profit.

CUTTING WELL DRILL THREADS

By D. A. Hampson
MACHINISTS who have never lived in the oil country or done artesian well work, have missed a branch of the business which is both rugged and interesting. The various well drillers' tools are bits, stems, jars, and drills, and are assembled in a "string" which is sus-

A bar of 1 1/4 in. x 3 in. cold drawn steel was clamped to two slotted parallels which were bolted across the ways of the lathe. This bar was set to the right taper and it was purposed to make the cross slide follow this taper as the carriage travelled. This was done by removing the cross feed screw and hanging a 50 lb. weight by a cord passing over the sheave wheel and attached to the cross slide member. The roller shown on the inside of the steel bar was set on an extension piece bolted to the side of the cross slide. This completed the taper arrangements. It may be added that they worked perfectly.

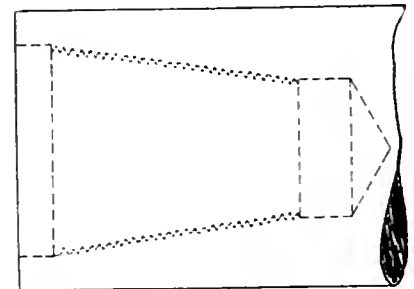
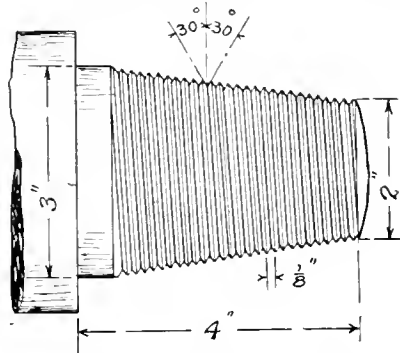

TYPE OF THREAD USED FOR COUPLING OIL WELL TOOLS.

ended at the end of a rope sometimes a quarter of a mile long, the "length" being depth down in the barrels of the earth. The tools are all forgings and are jomed to each other by threaded joints of a decided taper. A typical joint is shown by the drawing which also shows the angle and pitch of the teeth. This is practically the accepted standard.

The form of end is not made so "a man will have to send back to the factory for repairs" but to facilitate field assembling, to prevent trouble with crossed threads, and mainly, to make it easier to screw two pieces together down in the bottom of a hole. Fishing

A reverse in the carriage was used for thread cutting just as with any threads but as the cross feed screw was removed and the lathe had no compound rest it was necessary to average for withdrawing the tool for every backing up of the carriage. This unit took the shape of a crude compound rest and was made up of parts on hand, the basis of which was a slide and its shoe, very well fitting, the end of one member showing in the photo by two upright ears through which a rod has passed on some previous job. In the solid metal just below these ears, a hole was drilled for a tool and a set screw for the latter put in.

SAVING LEAD IN HARDENING BATH

By D. A. Hampson
A manufacturer of butcher and carving knives took a contract for hardening and tempering bayonets—for which he had an almost perfect equipment. His method was to heat them point down in tanks of molten lead. About that time

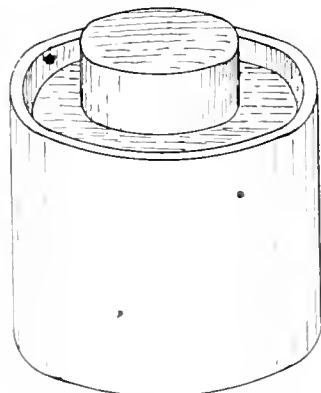

LEAD SAVING DEVICE USED IN HARDENING BATH.

the price of lead jumped and became a serious item, as each tank held a volume of it 30 in. in diameter by 22 in. deep. A scheme for reducing the volume of lead was evolved. It was to set a cylinder of cast iron about 18 in. dia. in the center of each tank displacing about 1400 lbs. of lead and it was quite successful. Once heated red hot it retained the heat very well, and hardening was just as efficient as before. Besides be-

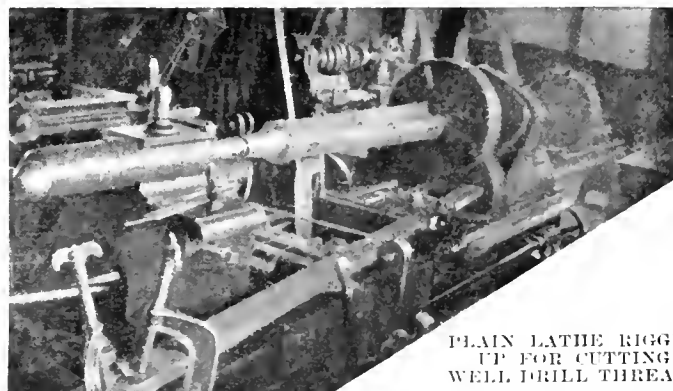

PLAIN LATHE RIGGED UP FOR CUTTING WELL DRILL THREADS

out lost tools and screwing up joints a thousand feet out of sight is an everyday job to a well driller and the steep taper plays an important part. Tailstocks on ordinary lathes and taper attachments do not have enough set over for well threads and when they are cut outside of the maker's plant, it is a case of rig up for the job. The job of cutting some new male threads came into a shop that had nothing but the plainest of lathes to work with but by rigging up as shown in the photo, it was done very nicely.

Then an idle screw and a machine crank were added and the unit was complete ready to bolt in place of the ordinary tool post.

While a great deal of rigging up seems necessary for such a job, the special parts can be kept and used again at a profit. When a well driller has a break down, he usually has three or four men at good wages whose time goes on, work or not, and he is willing to pay any price in reason—and a little more—to be helped out.

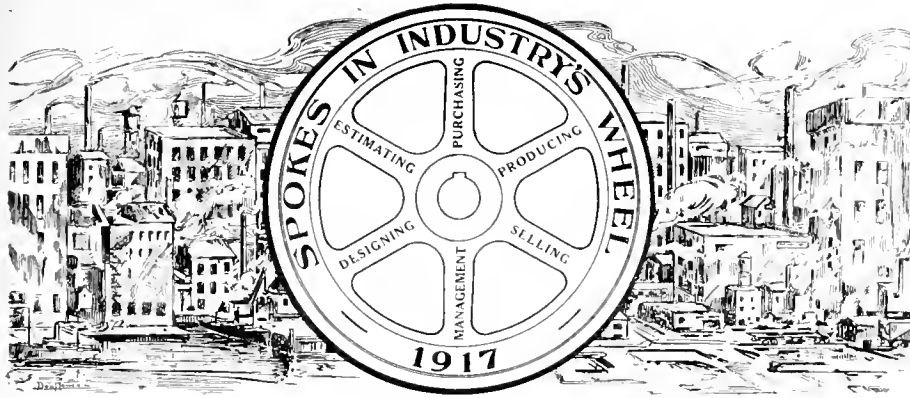

The constitution of industrial enterprise is largely departmental—"spokes in a wheel." This series of articles has for its object the featuring in a racy, interesting and instructive fashion, the training, experience and achievement of those who to-day are transmitting, effectively, energy in their capacity as "spokes in the wheels" of our metal-working establishments.

HERBERT WILLIAM CARTER

A STUDY of industrial developments in Canada during the past decade reveals a series of fortunate happenings combining the elements of time place and man. In most branches of industry it will be found that the last ten years have witnessed several developments in machines, methods and processes, the lack of any of which at this time would be a national handicap, and the future possession of which will not be without considerable influence, even though indirectly, on the development of the country. Present efforts in the field of industrial research will yield results in time, but it may be questioned whether the future holds secrets of such particular importance to the engineering industry as say high speed steel, non-ferrous alloys and autogenous welding. The gradual and persistent manner in which the last of these, better known as the oxy-acetylene process, has permeated the entire industrial world is at once an evidence of its inherent merit and a tribute to the pioneers of the process. Future manufacturing developments in this country are bound to witness an increasing use of the process and considerable interest, therefore, attaches to the personality of our "Spoke" in this issue.

"Opportunities are made to be taken" and the success which has attended the business activities of Herbert William Carter, president of the Carter Welding Co., Ltd., Toronto, is evidence that he grasped the occasion as well as truth of the saying. While our Spoke's residence in Canada covers a period of about nine years, the fact that he has devoted all of this time to the development of oxy-acetylene welding accounts for him being regarded as much in the light of being an institution as well as a pioneer. This concentration of purpose is easily understood, however, when Mr. Carter's earlier experience is considered.

Born in Bristol, England, of English parents, Nov. 11, 1889, H. W. Carter passed through the curriculum of the usual English high school education,

and in 1904 began work as an apprentice in shops of the Rope Walk Iron Works, Bristol, of which his father was proprietor. Forgings for motor car parts were the principal output of the business, and ample opportunity was available for acquiring skill and knowledge in the handling of forge work, an experience which was to be of exceeding value in his chosen vocation here. Handicraft skill like other accomplishments is frequently hereditary, and the fact that Mr. Carter's father enjoyed a wide



HERBERT WILLIAM CARTER.

reputation as a forging expert in the land of his birth, may, to some considerable extent account for the success which has attended our "Spoke's" efforts in this country.

An extended experience in general garage work, and close intimacy with the leading motor car builders of England, during their most active period of development, still further fitted our friend for appreciating the possibilities of autogenous welding. Soon after his arrival in this country in 1908, Mr. Carter assumed the representation of Davis-Bournonville Co., whose

apparatus had attained a high degree of commercial efficiency, and the steady growth of the process in this country is to a large extent due to the faith of Mr. Carter in the possibilities of the process, the efficiency of the equipment he handles, and his own ability to accomplish what he sets out to do.

Prominent among his personal efforts was the developing of the use of oxygen for removing carbon from internal combustion engine cylinders, a line of effort resulting directly from his early days in the motor car business. More recent, but none the less important was development of an oxygen gas cutting-off machine which has already found considerable application in munitions manufacture, while the rapid extension of aeroplane building in this country has offered further opportunity for application of his inventive faculty.

Processes such as Mr. Carter's concerned with, become so closely interwoven with their numerous fields of application that their novelty is soon lost and only their merit remains; it will be of interest, however, to those of our readers who have used a "torch," to know that the man who made the first weld by oxy-acetylene in Canada is employed by Mr. Carter.

Despite the activity of his life in Canada, our friend has found time to maintain the English traditions of home and family; in 1912 he entered the bonds of matrimony. Mrs. Carter is also of English nationality, and is the mother of two sons, the family residence being at 944 Dufferin St., Toronto.

Mr. Carter's affiliation activities are limited to the A. O. of Buffalo of which he had the honor of being the youngest member at the time of his initiation; in religion he is Church of England.

Frequent opportunities for continental travel were fully availed of during his residence in Britain, and coast to coast trips in Canada and across the line have marked his stay here. Motoring is the principal recreation of our friend, although the investigation of oxy-acetylene applications and allied scientific work is prosecuted in a manner which combines work and play to a great extent.

As the pioneer of an industry, Mr. Carter has been deeply impressed with the value of technical journals as a means of collecting information, finding and developing prospects, and keeping in touch with the trade generally: "A new business, more than any other, must seek means for disseminating information amongst selected parties, and the technical paper of to-day not only does this very effectively, but does it continuously. Not only do the advertising features keep the various sections of the trades in constant touch with each other, but the editorial features assist in maintaining executives and employees in a state of greater efficiency. Young men entering new branches of business at this time can not afford to neglect any of the suggestions and inspirations which arise from the careful perusal of technical journals.

MOVING PICTURES OF MUNITIONS MAKING

THE John Bertram & Sons Co., of Dundas, Ont., who recently completed a large contract for 8-inch high explosive shell, arranged to have made a moving picture record of the operations. The work was undertaken under the direction of W. T. Sears, secretary of the Engineering Committee of the Niles-Bement-Pond Co., the pictures themselves being photographed by F. T. Van Syckel, staff photographer for the latter concern, who moved from one end of the shop to the other, aboard an overhead travelling crane.

The films take up the manufacture of eight-inch high explosive shell from the time the rough forging is received. A general view of the shell plant is first shown. Details of the various operations are clearly shown; the views being taken close up are unusually clear and

fortunate to see them exhibited in the interest of funds for the Patriotic Society of the town of Dundas, where the Bertram plant is located.



GOVERNMENT CONTROL FOR ALL BRITISH INDUSTRIES

LATEST advices from London state that the Government has introduced a bill which is almost certain to pass quickly, which provides for State domination of practically all industries. The munition acts, already effective, enumerate many industries which the Minister of Munitions may take over and operate for the Government. The new bill proposes to give the Minister of Munitions power to do this with any industry if it is deemed necessary, thus making the whole industry of the nation a war works.

ors, a Swiss engineer, has been for several years in successful operation in many European countries, and is now being adopted by progressive Canadian and American manufacturers.

In the Schoop process, the coating adheres to the object chiefly by mechanical union. The apparatus is so designed that either hydrogen, Blau, or acetylene gas are used in conjunction with oxygen, the reducing gas being always in excess so that oxidization of the metals is prevented. Compressed air discharges the products of combustion at a high velocity so that the molecular spray by penetration secures a perfect adherence to the surface being coated, and rapidly builds up to the depth required.

All kinds of protective metals and their alloys can be utilized and applied to metals, wood, paper, stone, clay, cement, cotton and silk fabrics, and glass.

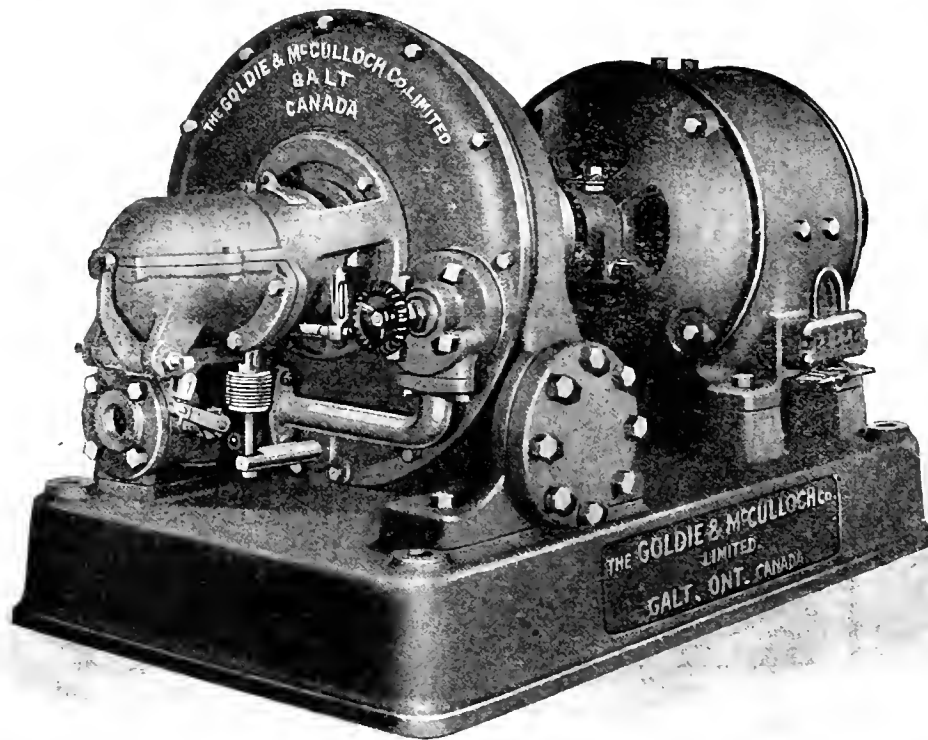

TURBINE-DRIVEN SHIP LIGHTING SET.

distinct. The film, which is in five parts, traces the entire series of operations right through until the finished shell is boxed ready for shipment. An interesting feature was the statement preceding each operation, giving the time required; another was the Government inspection, which demonstrated the many gauges used.

A pleasing introduction to the film was the appearance of the photograph of the founder of the business, John Bertram, and the present head, Henry Bertram. A group picture showing the foremen, and another showing the Government inspectors were included. It is understood that the pictures were taken entirely as a matter of record, and will be carefully preserved by the John Bertram & Sons Co. A representative of this publication was

The bill provides that in case the Government takes over a given industry many. During the past year at least one governing output and conditions of workmen and the like, then limitations on profits also will be imposed.



DEMONSTRATION OF METAL SPRAYING PROCESS.

CONSIDERABLE interest was manifested by manufacturers in Toronto and Western Ontario in a recent demonstration of the Schoop Process of Metal Spraying by the Metals Coating Co., of Canada, Ltd., at the plant of the Dominion Bridge Co., Toronto. Although, a comparatively recent accomplishment, the Schoop process, which takes its name from one of its prominent spons-

NEW ZEALAND TRADE FOR CANADA

A REPORT received by the Department of Trade and Commerce, Ottawa, from Canadian Trade Commissioner Beddoe, of Auckland, says that a Canadian firm recently sent out to New Zealand samples of lead pencils, the first made in Canada following the stopping of the Austrian supply. Mr. Beddoe says that the samples were found very satisfactory, and substantial orders have been sent to Canada. He also notes that if Canadian firms were not so busy with war orders they could capture in New Zealand a much greater proportion of the business formerly enjoyed by Germany. During the past year at least one million dollars' worth of New Zealand orders offered to Canadian firms could not be filled.

EDITORIAL CORRESPONDENCE

Embracing the Further Discussion of Previously Published Articles, Inquiries for General Information, Observations and Suggestions—Your Co-operation is Invited

MACHINISTS' INSTRUCTION COURSE—XVII.

By J. Davies.

IF the size or shape of the work prevent it being held in the vise, it may be bolted to the table by means of the bolts and plates already described. Work on the planer or shaper is usually

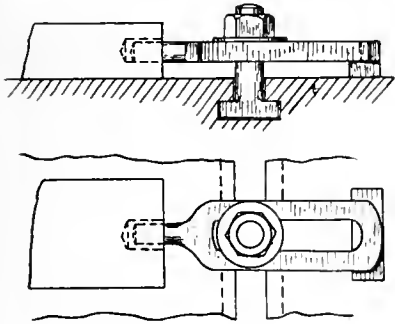

FIG. 61.

set up by means of the surface gauge; although this is not by any means an infallible test, it is usually accurate enough for ordinary work. A more accurate way is to test by the tool itself, after setting up the work, as the shaper table is not always in line with the travel of the tool, neither is the bridge or cross rail of the planer always parallel with the table.

Bolting Down the Work

Few machinists realize how easily a casting, even of very large size, can be sprung by careless bolting down to the table. Before finishing a casting on the planer that needs to be machined very accurately, it should be roughed all over, as in some castings, depending largely upon their shape, there is a certain amount of internal stress due to unequal cooling in the mould, and they are liable to spring a little when the outer surface has been removed. If a piece of work is to be planed parallel top and bottom, af-

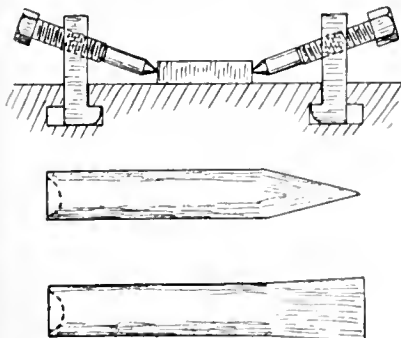

FIG. 62.

ter being set up in the required position, any uneven places at the bottom should be packed up so as to give a good solid bearing surface before being finally bolted down; otherwise the work will be

sprung by the bolting down, and when the bolts are released it will go back nearly to its original shape, with the result that the planed surface will not be true.

Sometimes a piece of flat work is to be finished on both sides, and it is found that there is no place to put the clamps except on the top surface, so that some other means must be found to hold down the work. If the work is thick enough and holes are no detriment, these may be drilled in the sides or edges of the work, and the work bolted down by using finger clamps, Fig. 61.

When it is undesirable to drill holes in the work, toe clamps are usually resorted to. This equipment consists of pieces of wrought iron or steel made to fit the slots of the table, with a hole drilled and tapped at a slight angle to receive a set screw. Pieces of steel of a suitable length are ground, one end with a ball point to fit the cupped end of the set screws, the other with either a chisel or centre punch end to press against the work (see Fig. 62). Care must be taken that the angle of the toe dog is not too great—the angle of the tapped hole is usually 8 or 10 deg., just enough to insure that the dog will press the work hard down to the table. When using toe dogs, stop pins must be used to prevent the work slipping on the table. When

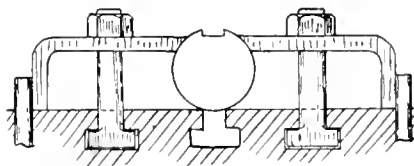

FIG. 63.

using chisel-pointed toe-dogs, cup out the ends and use pointed set screws.

If a long, round shaft is to have a key-way or spline, cut from end to end, it may be bolted to the table in a somewhat similar manner by placing the shaft in one of the longitudinal slots and bolting at the sides with plates, as shown in Fig. 63.

For short, round shafts it may be convenient to support the end on V-blocks and grip the centre by the vise.

Planing Curves

Many are the ingenious devices used on the planer for special work. Mention is made of one or two of those most likely to be met with in ordinary machine shop work. The first is a device used for planing a curved surface on a casting.

Fig. 64 shows one form of a special rig for planing curved surfaces. A special head or an extension to the ordinary head is made to swing on a pin on the upper cross brace, the distance from the centre of the pin to the point of the tool being the same as the radius of the de-

sired curve. It may be necessary to remove the ordinary feed screw to allow for the swing of the tool, and some temporary device made to feed the tool across the work. These devices may vary somewhat, according to the construction of the machine, but the prin-

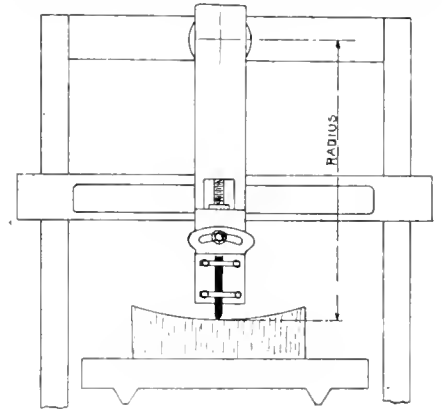

FIG. 64.

ciple of planing curved surfaces is the same.

Planing Links

In planing links, such as are used for locomotives, etc., the tool is stationary except for the downward feed, and the work is made to travel through a curved path. This is accomplished in several ways. The most satisfactory is where the work is bolted to an extra table held between strips, which hold it from moving lengthwise on the table, but allow it to travel transversely across the table (see Fig. 65). Attached to this extra table is a bar with a hole in it the required radius. Through this hole passes a pivot pin, which is fastened to some secure support. If it is a very large radius, which requires but a very slight cross motion of the extra table and necessarily a very long arm, the support for this pivot pin would probably be on a special

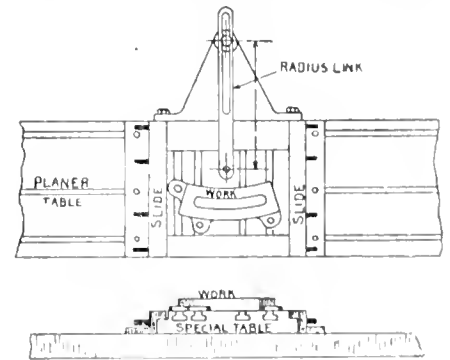

FIG. 65.

concrete foundation of its own. If the radius is a very small one and the pivot pin must be close up to the planer table, it can be very conveniently supported by a bracket bolted to the side of the

planer. As the table moves backwards and forwards the extra plate to which the work is fastened rotates about the centre of the pivot pin, and in so doing slides backwards and forwards across the table. Where frequent variations in radius occur, the link may be slotted and the pivot pin adjusted to different radii, as shown in sketch.

Work Between Centres

A pair of centres is a very useful attachment for some planer work, such as planing the corrugations in long rolls used in making corrugated paper. In work of this kind it is advisable to fasten a gear on to the shaft to be used as an index for planing the right number of teeth or corrugations. The spacing is done by making a spring finger to fit the teeth and fasten to the table (Fig. 66).

Spirals can be cut in much the same way. In cutting spirals, a clamp is fastened to the work with the end extending across the table. The end of this clamp

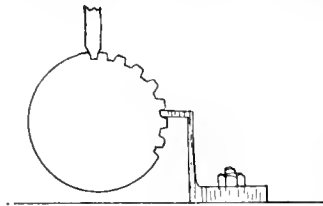

FIG. 66.

travels up and down an inclined plane that is fastened to the housing of the planer, and is kept in contact with it by a suitable weight. As the table travels backwards and forwards, on account of the inclined position of the piece bolted to the housing, it forces the work to make a partial revolution with each stroke of the planer. By varying the angle of this bar, the amount of travel on the work can be regulated. The steeper the angle formed, the steeper will be the pitch of the spiral. The planing is done with a tool formed to the desired shape. The right number of spirals can be obtained by a ratchet wheel arrangement, which can be made to move any number of teeth each stroke of the table.



GROUP OF CYLINDERS RECLAIMED BY OXY-ACETYLENE WELDING

BOILING PATCHING WITH OXY-ACETYLENE.

By S. W.

THE accompanying photograph shows a method which has recently been adopted for applying patches to boilers, whether inside the firebox or outside the shell. The old method was to fit the patch over the weak plate, making a lap joint all around, which was finally riveted into position, after which stay-bolt holes were drilled, applied and riveted. Much blacksmith work is necessitated in the fitting. The new method consists of cutting out the weak place with the oxy-acetylene cutting torch, then cutting a piece of plate to fit hole,

source of power that they once were, and still should be, because of the recent rise in price of gasoline. A gasoline engine in good working order, and with gasoline at fifteen to twenty cents a gallon, is as satisfactory and as cheap a form of power as any other within the reach of the average farm.

Some years ago, gasoline was considered fairly good in quality when it tested 70-72 (Baume scale). At the present time it tests all the way from 59 to 66, which means that the speed with which it evaporates has decreased by the difference between these figures. In other words, volatility, which is the quality which makes it valuable as an internal

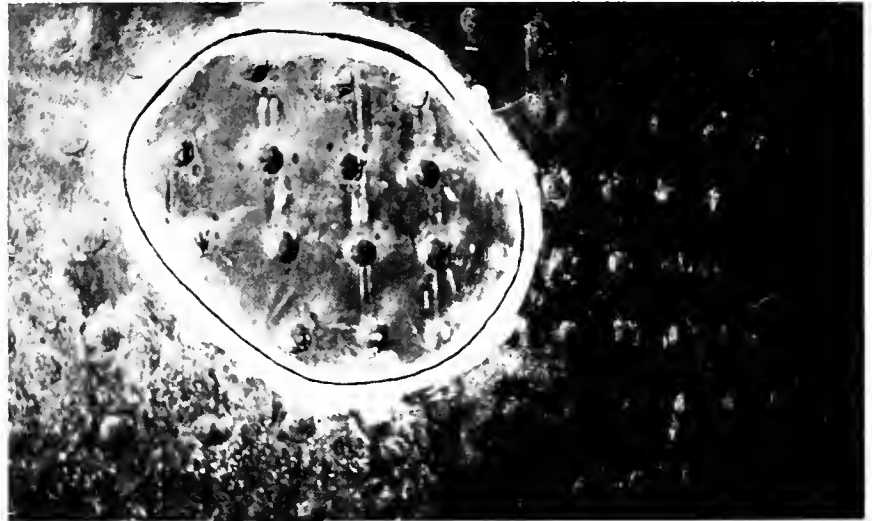

PATCH ON LOCOMOTIVE FIRE-BOX HELD IN PLACE BY NEW STAY BOLTS PREPARATORY TO WELDING UP EDGES.

after which staybolt holes are drilled and applied, thus holding the patch in position as shown in photograph. A vee groove is now chipped around the joint and the crack welded up solid to main plate with oxy-acetylene welding torch. Cost of new method less than half that of old.

RECLAIMING SCRAP CYLINDERS

By E. T. S.

OWING to changes in the design of our equipment, a large number of long air reservoirs were put out of service. These were carefully stored in the museum, and when an opportunity occurred in which it was possible to use up this stock, were cut to the length required, by the oxy-acetylene process, and the old end was welded in by the same process in the new position. The cost of these tanks new would have been \$7.80 each, and the cost of cutting the old tanks down was \$3.37 each, making a saving of \$4.43 each, accomplished entirely by a system of "checking the scrap."

KEROSENE AS A GAS ENGINE FUEL

By L. G. Reimpel, O.A.C.

THERE are hundreds of gasoline engines in use on Ontario farms at the present time, which are not the cheap

combustion engine fuel, has deteriorated by that amount. The hydrometer (Baume scale), gives the test of average kerosene (coal oil), as from 42 to 46, which shows us that the difference between the volatility of coal oil and that of gasoline is growing less. In spite of the fact that the quality of gasoline is deteriorating we find the price rising—almost doubling that of a few years ago—and it behooves us to find some way of using a cheaper fuel for our gasoline engines.

Kerosene As a Substitute

For this purpose we have found kerosene, as well as naphtha and fuel oil, to be quite satisfactory. Furthermore, it is an easy matter, as well as one that involves little expense, for any man who has taken the trouble to find out why and how his engine runs, to convert his engine, which was made to burn gasoline, into a kerosene burning engine.

The Relation of Kerosene and Gasoline

Before going on to describe the essentials of a coal oil burning device, we shall endeavor to show what gasoline and kerosene are, and how closely these products of the oil refinery are related. Both are products of petroleum. The crude petroleum is distilled in large iron stills and purified. The mass of oil is heated from 120 degs. C. to 150 degs. C. and held at, or near, the highest point mentioned, and all the vapor that passes

off at that temperature is called gasoline. When no more vapor passes off, the temperature of the mass is raised from 150 degs. C. to 300 degs. C., and all vapor passing off at that temperature is condensed in a separate tank and forms such products as kerosene, naphtha and fuel oils. Kerosene is therefore composed of the same constituents as gaso-

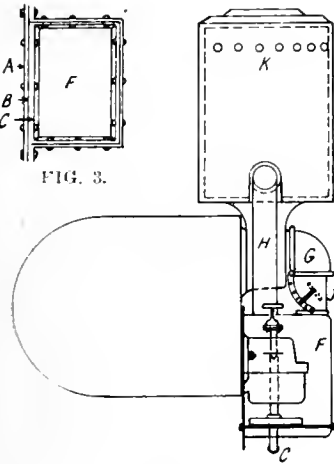

FIG. 1.

line, but it will not evaporate as readily as the latter, and it contains a larger percentage of carbon. Kerosene really contains more heat units per gallon than gasoline, but the problem before us is—how to get them out?

The conditions essential to the burning of kerosene are:—

1. Kerosene must be heated to its evaporating point outside of the cylinder and held at that point until it is ignited by the electric spark in the explosion chamber.
2. The air which is drawn in through the carburetor must be heated.
3. Water must be fed into the cylinder at the same time.

Heating the Oil

It is first of all necessary to state that up to the present we have discovered no satisfactory method of starting our engines on anything but gasoline, and hence appliances for this purpose must be provided. There are two kinds of fuel feeds in use at the present time—first, the gravity feed, in which the fuel tank is above the carburetor and the feed regulated by a float or diaphragm, and second, the constant level feed, in which we have the fuel level kept uniform by pumping a surplus of fuel into it; the excess running back to the tank through the overflow pipe.

The devices employed for heating the fuel in a gravity-feed engine are illustrated in Figs 1 and 2. Fig. 1 representing an end view of a cylinder, carburetor and muffler of a gasoline engine, while Fig. 2 is a side view of the same. The dotted lines show the carburetor and heating tank D as they are enclosed in the box F.

On its way from the tank to the cylinder the oil passes through pipe A in the stand-pipe B, which is also a sedi-

ment and water trap, then through pipe C into heating tank D, from which it is drawn into the expansion chamber through the needle valve E. The heating tank should be either a thin rectangular tank holding from one-half to three-fourths of a pint of fuel, depending on the size of the engine, or it may consist of a coil of perhaps six or eight feet of 1/4 in. flexible copper tubing in which the oil is heated. In order to keep the fuel hot enough it is necessary to heat the carburetor as well as the oil; this is done by enclosing the carburetor in the sheet iron box F and piping about 40 or 50 per cent. of the exhaust of the engine into it, allowing it to escape through a hole in the opposite corner of the box. This is done by cutting a hole into the exhaust manifold and leading the exhaust through pipe G into the heating box. In Fig. 1, J shows a home-made butterfly valve by which the amount of heat entering the heating box can be diminished or increased at will. The construction of the heating box F is explained in Fig. 3, and with a little modification a similar device can be made to fit almost any engine. In Fig. 3, A is a stiff sheet iron plate which is held in place by being clamped in with the gasket on the studs which hold the carburetor. The top, bottom and one side of this box are one piece of metal bent to shape. The ends are of the same material and are fastened to the sides by bending the edges to form a flange, then bolting the sides and edges together with stove bolts. The joints can be made as tight as necessary by inserting a layer of asbestos paper.

Starting an Engine

The operation of starting an engine equipped in this manner is as follows:—

1. Close stop-cock M so as to prevent kerosene from running into the carburetor.
2. Drain the kerosene out of the car-

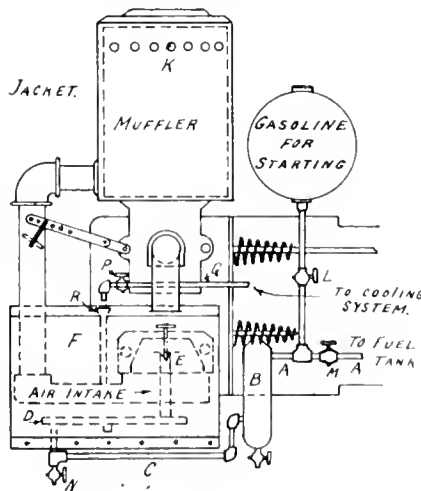

FIG. 2.

bu-er and heating tank through stop-cock N, after which close N.

3. Open stop-cock L to allow gasoline to run into carburetor and start the engine as usual. When it is hot, all that is necessary to change to kerosene is to

close stop-cock L and opening M, so as to allow the kerosene free passage to the carburetor.

The principle for heating the fuel in an engine with a pump and constant level fuel feed remains the same, but since a far larger amount of fuel is being pumped through the system than the engine requires, it follows that the tank heater is not efficient. Therefore, we must resort to such a device as is

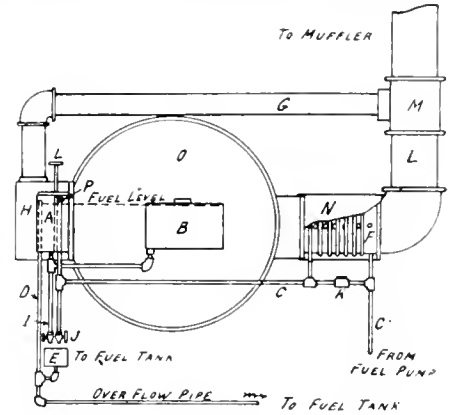

FIG. 4.

shown in Fig. 4. In this figure, O is the end of the cylinder of the engine; F is a coil of about 15 feet of quarter-inch pipe coiled around the exhaust pipe into which a series of holes have been drilled for the escape of hot gases; N is a sheet iron cover which encloses the coil of pipe.

The fuel is pumped through the pipe C, Fig. 4, into the carburetor at P, and the excess returns to the tank through overflow-pipe D. When kerosene is used the valve K is closed and the oil is forced through the coil F where it is heated. When gasoline is used as fuel, opening of the valve K will allow the passage of the gasoline without heating it.

The heating of the carburetor is brought about in a manner similar to that in Figs. 1 and 2.

In starting an engine equipped as in Fig. 4, the following points are necessary:—

1. Drain kerosene out of carburetor through pet-cock on pipe I.
2. Fill tank B with gasoline. This tank should be large enough to hold for 20 minutes running. It is placed so that its top is level with the top of the carburetor and its bottom level with the bottom of the carburetor.
3. The pet-cock J is opened so as to allow the escape of all kerosene which is pumped through the pipe C, back to the tank.
4. Start the engine and when gasoline is run out turn on the kerosene by closing pet-cock J.

Heating the Air

It is necessary to heat the air so as to prevent condensation of the vaporized fuel particles into the liquid by the inrush of cold air into the air tanks. This is very important, and if the passage between the carburetor and the cylinder is a long one, and in a multicylinder en-

gine it must be jacketed and heated with exhaust or the fuel mixture will condense on its way to the explosion chamber.

The best way to heat the air is to force the intake air to be drawn over the hot surface of the muffler or exhaust pipe. In Fig. 2 is shown a muffler with a jacket of sheet iron. The space between the jacket and the muffler should be no more than half an inch. All the air is drawn in through the holes K at the top of the muffler and is conducted through the pipe H to the carbureter.

The Feeding of Water

Water is fed into the carbureter of a kerosene burning engine for two purposes, to prevent "knocking" and to prevent carbon deposits in the cylinder and consequent fouling of the ignition apparatus. Modern kerosene burning engines are fitted with a water carbureter of similar design as the fuel carbureter, but when remodelling an engine not fitted for kerosene we find that a device such as is illustrated in Fig. 2 answers the purpose very well. Water taken from the cooling system of the engine passes through pipe Q and drops into the funnel R, thence into the air intake. The amount of water fed can be regulated by pet-cock P.

During the summer of 1916 we used a device as just described on the twenty horse-power engine driving the traction ditching machine used as a demonstrator by the Department of Physics of the Ontario Agricultural College. The writer made a number of actual working tests for the purpose of ascertaining the efficiency of kerosene and other cheap fuel oils as compared with that of gasoline. In each test we found that the gallon of kerosene did as much work as a gallon of gasoline. This means that with kerosene at from 12 to 13 cents a gallon and gasoline at from 33 to 35 cents, our fuel bill was cut to less than half of what it would have been had we been burning gasoline. Gasoline is high in price; the demand is growing; and the supply is limited; therefore we cannot see that it is likely to become any cheaper. For these reasons we hold that gas engine owners cannot do better than to equip their engines so as to burn kerosene.

TESTS OF URANIUM AND OTHER HIGH SPEED STEELS

THE difficulty of obtaining reliable comparisons of high speed steels under ordinary shop conditions are known to all students of the subject, and recent efforts by the Standard Alloys Co., Pittsburgh, to obtain accurate figures were somewhat nullified due to the presence of hard spots, extra high carbon, and similar inequalities which made it impossible to figure one steel in terms of the other.

Four bars of high speed steel each having different chemical composition, were tested with a view to determining their relative physical fitness for lathe tools. The work they were tested on

consisted of turning forged pinion blanks from 5 to 6 in. dia. the material being very uniform both chemically and physically, so that a good comparison between the tools was obtained. The pinions were turned at an average speed of 54 ft. per min. with 1-32 in. feed and 5-32 in. depth of cut. The alloy in uranium tool No. 1, was charged with the metal, and in No. 3 was charged after the steel had melted. This difference in charging caused No. 1 tool to have less uranium than No. 3. In uranium tool No. 966, the elements were in very good proportions to give hardness and strength. Tool A was a high speed steel of recognized quality taken from the ordinary stock in the shop.

COMPARATIVE WORK DONE BY HIGH SPEED STEELS.

Tool	Av. No. Pinions Faced	Dia.	Face	Distance along Axis	Area Turned sq. ft.
Uran.	1	5.6"	4.81"	21.38'	27.14
"	2	5.45"	5"	21.9'	32.52
"	966	5.68"	5.2"	24.0'	33.78
A	45	5.75"	5"	18.6'	28.05

The results obtained as shown in the accompanying table are obtained by averaging up from three to four grindings, so as to get a more accurate test than when single grindings only are considered. The number of pinions turned is mentioned to give an idea of the amount of work turned.

It will be noticed the tool A showed up slightly better than tool No. 1, while both tool No. 3 and tool No. 966 are about even in their cutting ability, and both surpass tool A.



SAFETY IN THE MACHINE SHOP—THE AUTOMATIC MACHINE DEPARTMENT

Travelers Standard

THE most successful manufacturers of to-day are giving a great deal of study to the methods employed in their plants, with a view to increased efficiency. Keen competition has forced out of business many of those who were unwilling or financially unable to adopt the most approved methods and practices, and to install labor-saving and time-saving machines and devices.

The improvements in metal-working machines have been particularly noteworthy. A comparatively few years ago, with the tools then in use, the services of a skilled machinist were required to perform even the simpler operations in metal working. Especially was this true when a number of duplicate parts were required, the value of which would be impaired by the slightest variation in size or style. Men who could turn out satisfactory work of this kind were in great demand and consequently were well paid. Now, after a few days' training, an unskilled workman may be put in charge of one or more automatic machines which will produce thousands of small objects per day, which will be absolutely uniform in size and style.

Automatic Machine Features

The modern automatic screw machine, as used at the present time in practically

all manufacturing machine shops, is by no means limited to the production of screws. It turns out bolts, nuts, and gear blanks, and various parts of locks, fuses, spark plugs, guns, typewriters, and automobiles, as well as other objects in great variety. The automatic screw machine is the result of a process of evolution. The first screws made were cut by hand with crude implements, and this laborious hand-method was followed for a great many years. In 1775, however, the first metal-working lathe was constructed and used in England, and for a long time thereafter it was employed for manufacturing screws, bolts, and nuts, and duplicate parts of various kinds, although it was extremely

inefficient for this particular kind of work, from a modern point of view. With this machine, the production of small duplicate parts was limited, because a great deal of time was consumed in placing and securing the stock in changing the tools, which necessitated frequent starting and stopping of the lathe.

These objections were overcome and better results were obtained, as regards quantity and uniformity of production, by the hand screw machine which was subsequently developed. With this device, the tools could be set in position and swung to the work by the operator without stopping the machine, and consequently a considerable saving of labor and time was effected. The automatic screw machine soon followed, and this performs the operations of feeding the stock, chucking, and bringing the tool to position automatically, by mechanical means. All that is required of the operator is to make sure that the tools are sharp, to keep the automatic mechanism in proper adjustment, and to supply stock. The multiple-spindle automatic machine is the latest development in equipment of this kind.

Accident Possibilities

Accidents occur in connection with automatic machines, as well as with machines of every other kind; and although the injuries are usually of a minor nature, some of them are quite serious, and occasionally a fatality occurs. Hence it is well worth while to consider what can be done to increase the safety of the employees, and a few of the points that should receive attention are mentioned in the following paragraphs.

Storage and Transportation of Stock

In a good-sized machine shop there may be two hundred or more automatic machines, which may turn into finished products perhaps forty tons of bar stock per day. The bars that are used are often as large as 3½ inches in diameter and 12 feet or more in length, and a great number must be kept in stock in

order to avoid delays and shut-downs. It is, therefore, important to have a suitable place for storing them, and to see that they are piled in a safe manner, so that they cannot roll and injure the hands or feet of the workmen. The bars should be assorted according to size, and should be kept in strong, substantial racks so that any required size may be had without delay or inconvenience.

The work of unloading the bars from the railroad cars and transporting them to the stock room is also of a more or less dangerous character. The bars should be unloaded in such a way that none of them will overhang, or be left in such positions that they may roll or slide; and they should preferably be kept in a horizontal position while being unloaded. If conveyors are used, precautions should be taken to prevent the bars from rolling off them, or from interfering with the conveying mechanism in any way, or from injuring persons who may be near. Hand hoists are frequently employed, and then it is essential to see that the slings and all parts of the hoisting apparatus are kept in safe condition.

Machine Guards

It is highly important to provide adequate guards for all the exposed gears, clutches, driving belts, and pulleys on the automatic machines, because the floors around these machines are made quite slippery by the cutting oil that is constantly thrown from the tools as the stream of oil strikes them. Many injuries are due to persons slipping and coming in contact with unprotected gears and belts. It is advisable to place sheet metal screens about the machines to intercept the oil, but even when this precaution is taken more or less oil will be spattered about. It should not be allowed to accumulate in any considerable quantity, however, but should be cleaned up promptly and systematically. Sometimes the floor about the machines is covered with tin or sheet metal, but we do not approve of this because it tends to make the floors more slippery. Oily floors should be washed daily with hot water containing strong alkaline soap. When sawdust is sprinkled upon the floors, it should not be left long enough to become thoroughly saturated with oil, but should be changed frequently. To reduce the likelihood of slipping, the soles and heels of the shoes worn by the employees should be made of leather instead of rubber.

So far as possible, bars of stock should be of such a length that they will not project beyond the ends of the extension guards of the machines. Otherwise, loose clothing may be caught and wound up on the revolving bars; or, if they are of small size, the bars may wobble about and strike persons who may be near. Substantial racks should be attached to the machines, or be located near them, upon which a temporary supply of bars may be kept. This is much safer than laying them upon the floor, where they are likely to roll about and cause persons to fall or stumble.

Shafting, Belt, and Pulleys Guards

The shafting, belts, and pulleys, underneath the slotting and threading machines, should be effectively guarded so that the clothing of the employees (particularly the skirts of women operators) will not become caught. The women should keep their hair closely confined by means of caps or nets, so that it may not be caught in moving machinery, and none of the operators should be allowed to wear loose-fitting, torn, or ragged garments. The automatic slotting and shaving machine is quite ingenious. The serews are fed to it through a hopper, and the heads are slotted and shaved automatically. The chief danger, here, is that the employees may come in contact with the rapidly-revolving saw, or have their clothing caught in the shafting. Suitable guards should be installed, therefore, to avert accidents of this kind so far as possible.

Heading machines are frequently used for the production of various special kinds of nails and serews. These machines use a wire stock, which is fed automatically from a coil. The head is formed by "upsetting" the end of the wire by a heavy blow, and at the same time the piece is cut off to the correct length. The pulleys and driving belts on a machine of this kind should be effectively guarded. This is of special importance, because the machines are often set quite closely together. As a rule, the noise in this department is almost deafening, and it should be reduced as much as practicable. This may be accomplished, in part at least, by interposing felt or some other equally effective insulating material between the floor and the machines. In this way the shocks and noise may be materially deadened, and the vibrations checked. After coming from the heading machines the blanks are placed in tumbling barrels to be cleaned, and frequently the threads are formed by thread-rolling machines. The pulleys, driving belts, and balance wheels on the thread-rolling machines should be efficiently guarded, particularly when the space between the machines is insufficient to insure the safe passage of the employees.

Condition of Tools

The tools for automatic machines must be kept in good cutting condition, and consequently they must be frequently ground on emery wheels. Eye-protectors should be worn by the men who do the grinding, because many injuries are caused by particles of steel or emery lodging in the eyes. The dressing of the grinding wheels must also be done with the utmost caution, if accidents are to be avoided.

Oil Removal From Chips

The method used for treating the metal chips and scraps, in order to save the large amounts of cutting oil with which they are covered, is worthy of consideration. The chips are shoveled into baskets, which are then placed in a centrifugal extractor which removes the oil from the chips by centrifugal force when the machine is set in motion. The extractors are operated at high speed, and,

therefore, the covers holding the baskets should be securely fastened before starting the machines. There should be frequent inspections to make sure that none of the threads of the holding bolts or nuts have been stripped.

Serious accidents have been known to occur when these covers have become loosened and have been thrown off. The serews or bolts holding the base of the machine to the floor should also be periodically examined, because the excessive vibration may cause them to work loose; and if the floor is of wood the deteriorating effect of the soda water that is spilled from the cleaning troughs or tanks may also cause the bolts to loosen. The driving belt of the extractor should be guarded to a height of 6 feet above the floor, with a guard of sufficient strength to withstand any blow that might be given by the belt if it should break while moving at high speed.

The soda water tanks are usually low iron troughs in which the products of the various machines are immersed to remove any oil that may be upon them. The floors about these tanks or troughs are often in poor condition, and slippery; and the workmen engaged in the vicinity must be careful to avoid slipping or stumbling and falling into the tanks, where they may be severely scalded. Burns and scalds may also be caused by the careless dumping of serew machine products into the troughs, resulting in a considerable amount of unnecessary spattering of hot water.

Cuts and scratches on the hands are quite common in machine shops. These wounds should be immediately washed out with an antiseptic solution, and be carefully bound up to prevent infection. This precaution is important even in the case of very slight injuries, because serious cases of blood poisoning often result from small wounds that have not received proper care.

Infections From Cutting Oils

Considerable trouble is experienced in some shops from infections caused by certain kinds of cutting oil—namely the cheaper grades of lard oil. Cutting oils may be made from almost any kind of animal matter, and frequently no precautions are taken by the manufacturers to sterilize them. Moreover, even if the oil is free from germs when first used, it is likely to become infected later; and as the machine operators' hands are usually covered with the oil, any slight wounds or abrasions of the skin may allow the bacteria to enter the blood. To prevent trouble of this kind, it is advisable to sterilize the cutting oil before using it, and also at frequent intervals thereafter. The experiment is also being tried of mixing the cutting oil with a germicide of some kind (such as carbolic acid or cresol); but we do not yet know how effective this plan will prove to be.

Some plants simply use a sal soda solution, in place of cutting oil, for working soft metal, and paraffin oil for other operations. With these there is little danger of infection because there is no appreciable organic matter in them, upon which germs can thrive.

The MacLean Publishing Company

LIMITED

(ESTABLISHED 1888)

JOHN BAYNE MACLEAN President
H. T. HUNTER Vice-President
H. V. TYRRELL General Manager

PUBLISHERS OF

CANADIAN MACHINERY AND MANUFACTURING NEWS

A weekly newspaper devoted to the machinery and manufacturing interests.

PETER BAIN, M.E., Editor. B. G. NEWTON, Manager.
Associate Editors.

A. G. WEBSTER. J. M. WILSON, J. H. RODGERS.

Office of Publication, 143-153 University Avenue, Toronto, Ont.

Vol. XVII. APRIL 5, 1917 No 14.

POSSIBLE EFFECTS OF U.S. ENTRY

IT IS a foregone conclusion that by the time this issue is in the hands of our readers, the Government of the United States will be formally committed to the prosecution of war against Germany. President Wilson's address to Congress on the evening of April 2, stated that any further avoidance of hostilities was impossible in view of Germany's actions, and included a number of specific recommendations whereby the States might best help the Allied cause.

Of prime importance to Canadian manufacturers is that urging all preparations to be made in such a way as not to check the flow of war supplies to the nations already in the field against Germany. Coupled with this recommendation are others advising utmost practical co-operation in counsel and action with Allied Governments, and extension of liberal financial credits to those Governments, so that the resources of America may be added so far as possible to theirs. In view of the immense volume of domestic business now being done in the States and the high degree of efficiency attained by Canadian munition plants, coupled with the fact that recent developments have caused a reduction in demand for certain sizes of shells hitherto made here, it appears not unreasonable to suggest that surplus Canadian capacity might very well be availed of by the States with a view to avoiding any more disturbance to domestic business than necessary.

The actual extent to which preparations have been carried by our neighbor has been surrounded by increasing mystery of late, and it may be taken that co-operation with the Allies to the extent desired by the President will not fail to include co-ordination of effort so that regular trade in the States will suffer the least possible dislocation from sustained military effort.

Early developments will show to what degree it is advisable and possible for the American nation to participate in actual hostilities. That they will be called upon to

meet hostile forces on this continent armed with modern equipment, is extremely improbable, while the manner in which Britain has succeeded in arming herself and others discounts to a large degree the necessity for a feverish outburst of munitions manufacture by all and sundry. On the other hand, provided transportation was available, the supply of munitions on a large scale by the States would release many plants in Britain, so that serious efforts could be made by that country to regain lost trade and re-establish conditions which would have a permanent and ultimately more effective result in reducing the burden of war than would be the case otherwise.

The probability that the United States will raise funds by taxation instead of loans, accentuates the point brought up—that the necessity of maintaining a large trade volume in conjunction with the war-time treatment of tariff regulations, may well result in further accessions to Canadian munitions production.



ASCENDENCY OF BRITISH INDUSTRIAL INFLUENCE

CONSIDERABLE significance attaches to the action of the British Standards Committee, which recently decided to translate its specifications into French, Spanish and Russian, to give metric equivalents of English measures, and to issue the specifications at a much lower price than has hitherto been the case. Viewed in the light of present educational activity in Britain—increasing study of the Russian language and general intimacy with continental countries arising from existing conditions,—such action is indicative of a commercial awakening more significant as an event, and more far-reaching in its ultimate influences than any previous occurrence on parallel lines.

Further interest attaches to the statement that the Committee's decision was incorporated in the annual report of the Council of the Institution of Mechanical Engineers on the occasion of its seventieth annual general meeting in London. Members of the Society hold influential posts in all parts of the world and their natural desire to favor home regulations will receive considerable impetus thereby. The ever-increasing importance of the British mercantile marine and the duties discharged by the various supervisory bodies associated therewith, are two factors not without influence on the era of industrial activity presaged by recent happenings in the Western hemisphere.

Consideration of these incidents points to the fact that British influence, which has gained considerable ascendancy in world affairs since August, 1914, will not be allowed to suffer any ultimate setback through lack of care and attention on the part of technical and commercial bodies. Latest advices from England state that the Government will assume control of any industry which it deems necessary, an action which will make a war works of the whole nation. The intensification of British standards and methods resulting therefrom, coupled with the present dependence of the Allies on Britain's finance and industry, may well insure the future status of Britain as the controller of the world's markets. Canadian manufacturers should avail themselves of every opportunity of familiarizing themselves with the actions and influences of Britain's industrial interests.

INDUSTRIAL NOTABILITIES

JAMES ANDERSON COULTER, president and managing director, John Morrow Screw & Nut Co., Ingersoll; president, Ingersoll Hotel Co., was born in Hastings County, Ont., Dec. 11, 1868, son of James and Mary A. (Hargan) Coulter. On the completion of his education which was received at the Collegiate Institute, Seaforth, Ont., Mr. Coulter entered the employ of John Morrow & Co., as shipper, advancing in successive stages to his present position with the firm which was afterwards organized as John Morrow Machine Screw Co., and later re-organized into John Morrow Screw & Nut Co., Ltd.

The civic activities of Mr. Coulter have been quite extensive, including a term as Mayor of Ingersoll, 1907-1908; member of Town Council, four years; mem-



JAMES ANDERSON COULTER

ber Board of Education, seven years, and as chairman, one year; member Board Alexandra Hospital; member of Executive, Canadian Manufacturers' Association. He was also a Delegate to Imperial Congress of Chambers of Commerce of the Empire at London, England.

In 1892 Mr. Coulter married Elizabeth Maie Dundass, daughter of late William Dundass, Ingersoll, their family consisting of two daughters. His clubs are: National; Canadian; and Curling and Golf; also Ingersoll Amateur Athletic Association.

Affiliations and societies include, A.F. & A.M.; I.O.O.F.; and Canadian Order of Foresters. In politics, Mr. Coulter is Conservative, and in religion is Methodist, having been many times delegate to conference. The family residence is 2 Duke Street, Ingersoll, Ontario.

Photo courtesy British & Colonial Press.

SELECTED MARKET QUOTATIONS

Being a record of prices current on raw and finished material entering into the manufacture of mechanical and general engineering products.

FIG IRON.

Grey forge, Pittsburgh ..	\$34 95
Lake Superior, charcoal,	
Chicago	38 75
Standard low phos., Phila-	
delphia	70 00
Bessemer, Pittsburgh	38 55
Basic, Valley furnace	35 00

Montreal Toronto

Middlesboro, No. 3	
Cleveland, No. 3	
Clarence, No. 3	
Hamilton	42 60
Victoria	

FINISHED IRON AND STEEL.

Per lb. to Large Buyers	Cents
Iron bars, base, Toronto ..	4 25
Steel bars, base, Toronto ..	4 50
Steel bars, 2 in. to 4 in.	
base	6 00
Steel bars, 4 in. and larger	
base	7 00
Iron bars, base, Montreal ..	4 25
Steel bars, base, Montreal ..	4 50
Reinforcing bars, base ..	4 05
Bessemer rails, heavy, at	
mill	38 00
Steel bars, Pittsburgh	3 75
Tank plates, Pittsburgh ..	5 50
Beams and angles, Pitts-	
burgh	3 40
Steel hoops, Pittsburgh ..	4 00
F.O.B. Toronto Warehouse.	
Steel bars, base	4 50
Small shapes	5 00
F.O.B. Chicago Warehouse	
Steel bars	4 00
Bars, 2 in. and up	4 40
Structural shapes	4 25
Plates	5 50

FREIGHT RATES.

Pittsburgh to Following Points	Per 100 lbs.	C.L.	L.C.L.
Montreal	23.1	31.5	
St. John, N.B.	35.1	45.5	
Halifax	35.1	45.5	
Toronto	18.9	22.1	
Guelph	18.9	22.1	
London	18.9	22.1	
Windsor	18.9	22.1	
Winnipeg	64.9	85.1	

METALS.

	Montreal	Toronto
Lake copper	\$29 50	\$40 00
Electro copper	39 50	40 00
Castings, copper	38 50	39 00
Tin	55 50	56 00
Spelter	15 00	14 00
Lead	12 25	12 25
Antimony	28 00	26 00
Aluminum	70 00	68 00

Prices per 100 lbs.

BOILER PLATES.

	Montreal	Toronto
Plates, ¼ to ½	\$6 50	\$6 70
Heads	6 85	6 85
Tank plates, 3-16 in. ...	6 60	6 60

WROUGHT PIPE.

In effect March 29, 1917.			
Per 100 feet—	Black	Galv.	
Buttweld.			
1½ in.	\$ 4 50	\$ 6 00	
1¼ in.	3 90	6 00	
¾ in.	3 90	6 00	
¾ in.	5 10	6 67	
¾ in.	6 33	8 45	
1 in.	9 35	12 50	
1¼ in.	12 65	16 91	
1½ in.	15 13	20 21	
2 in.	20 35	27 20	
2¼ in.	22 18	43 00	
3 in.	42 08	56 23	
3½ in.	52 44	69 46	
4 in.	62 13	82 30	
Lapweld.			
2 in.	23 31	29 79	
2¼ in.	25 10	45 34	
3 in.	45 90	59 29	

¾ in.	57 04	74 06
¾ in.	67 58	87 75
1½ in.	78 74	102 20
5 in.	91 76	119 10
6 in.	119 00	154 60
7 in.	157 10	201 10
8 in.	165 00	211 30
8 L. in.	190 10	243 40
9 in.	227 70	291 50
10 L. in.	211 20	270 40
10 in.	271 90	348 10

Prices Ontario, Quebec and Maritime Provinces.

WROUGHT NIPPLES.

4" and under, 60%.	
4½" and larger, 55%.	
4" and under, running thread,	
40%.	
Standard couplings, 4" and under,	
50%.	
4½" and larger, 30%.	

OLD MATERIAL.

Dealers' Buying prices.			
		Montreal	Toronto
Copper, light	\$24 00	\$24 00	
Copper, crucible	28 00	28 00	
Copper, heavy	28 00	27 50	
Copper wire	28 00	28 00	
No. 1 machine composition	23 50	22 00	
New Brass clip-plugs	19 00	18 00	
No. 1 brass turnings	16 00	17 00	
Heavy Melting steel	17 00	16 00	
Steel turnings	12 00	9 00	
Boiler plate	15 00	10 50	
Rails	17 00	15 00	
Axles, wrought iron	22 00	24 00	
Rails	17 00	18 00	
Malleable scrap	15 00	11 00	
Pipe, wrought	12 50	9 00	
Heavy lead	9 00	10 00	
Tea lead	7 50	6 50	
Scrap zinc	9 00	10 00	
Aluminum	36 00	35 00	

BOLTS, NUTS AND SCREWS.

	Per Cent.
Coach and lag screws	30
Stove bolts	55
Plate washers	10
Machine bolts, 7-16 and over	10
Machine bolts, ¾ and less.	20
Blank bolts	10
Blot ends	10
Machine screws, fl. and rd. hd., steel	27½
Machine screws, o. and fil. hd., steel	10
Machine screws, fl. and rd. hd., brass	add 20
Machine screws, o. and fil. hd., brass	add 25
Nuts, square, up to 1 in., net list.	
Nuts, hex., up to 1 in., net list.	
Copper rivets and burrs, list plus	30
Burrs only list plus	50
Iron rivets and burrs	27½
Boiler rivets, base ¾-in. and larger	\$6.35
Structural rivets, as above 6.25	
Wood screws, flat, bright75
Wood screws, O. & R., bright70
Wood screws, flat, brass42½
Wood screws, O. & R., brass40
Wood screws, flat, bronze35
Wood screws, O. & R., bronze22½

MILLED PRODUCTS.

	Per cent.
Set screws	35
Sq. & Hex. Head Cap Screws	30
Rd. & Fil Head Cap Screws	10
Flat ¾ But. Hd. Cap Screws	10
plus	10
Fin. & Semi-fin. nuts up to 1 in.	25
Fin. and semi-fin. nuts, over 1 in., up to 1½ in.	30
Fin. and semi-fin. nuts, over 1½ in., up to 2 in.	10
Studs	20
Taper pins	40
Coupling bolts, plus	10
Planer head bolts, without fillet	10
Planer head bolts, with fillet	10 and 10
Planer head bolt nuts, same as finished nuts.	
Planer bolt washers	net
Hollow set screws	list plus 20
Collar screws	list plus 30, 10
Thumb screws	20
Trumb nuts	65
Patch bolts	add 40, 10
Cold pressed nuts to 1½ in.	add \$4.50
Cold pressed nuts over 1½ in.	add \$7.00
BILLETS.	
Per gross ton	
Bessemer billets	\$65 00
Open-hearth billets	65 00
O.I.L. sheet bars	72 50
Forging billets	90 00
Wire rods	85 00
F.o.b. Pittsburgh.	
Wire nails	5 00 4 95
Cut nails	4 70 4 70
Miscellaneous wire nails ..	60%
Pressed spikes, ¾ diam., 100 lbs.	4 60

NAILS AND SPIKES.

Wire nails	5 00 4 95
Cut nails	4 70 4 70
Miscellaneous wire nails ..	60%
Pressed spikes, ¾ diam., 100 lbs.	4 60

MISCELLANEOUS.

Solder, strictly	0 33
Solder, guaranteed	0 35
Babbitt metals	14 to 60
Soldering coppers, lb.	0 53
Putty, 100-lb. drums	4 00
White lead, pure, cwt.	14 25
Red dry lead, 100-lb. kegs. per cwt.	13 87
Glue, French medal, lb.	0 25
Tarred slaters' paper, roll 0 95	
Gasoline, per gal., bulk. ...	0 31½
Benzine, per gal., bulk. ...	0 30½
Pure turpentine, single bbls., gal.	0 69
Linsed oil, raw, single bbls.	1 49
Linsed oil, boiled, single bbls.	1 43
Plaster of Paris, per bbl. ...	2 50
Plumbers' oakum, per cwt. ...	8 00
Packing, square braided ...	0 27
Packing, No. 1 Italian	0 32
Packing, No. 2 Italian	0 25
Lead wool, per lb.	0 15
Pure Manila rope	0 29½
Transmission rope, Manila 0 37½	
Drilling cables, Manila ...	0 32½
POLISHED DRILL ROD.	
Discount off list, Montreal and Toronto	25%
CARBON DRILLS AND REAMERS.	
	Per Cent.
S.S. drills, wire sizes up to 52	40
S.S. drills, wire sizes, No. 53 to 80	25
Standard drills to 1½ in. ...	40
Standard drills, over 1½ in. ...	15
3-fluted drills, plus	10
Jobbers' and letter sizes	40
Bit stock	40
Ratchet drills	15
S.S. drills for wood	40
Wood boring brace drills	25
Electricians' bits	30
Socketts	30

Sleeves	40
Taper pin reamers	20
Drills and countersinks	list plus 30
Bridge reamers	45
Centre reamers	10
Chucking reamers	10
Hand reamers	15

COLD ROLLED SHAFTING.

At mill	list plus 40%
At warehouse	list plus 50%

Discounts off new list. Warehouse price at Montreal and Toronto.

IRON PIPE FITTINGS.

Canadian malleable, A, add 10%; B and C, 10%; cast iron, 35%; standard bushings, 50%; headers, 60; flanged unions, 40; malleable bushings, 50; nipples, 55; malleable lipped unions, 50.	
--	--

SHEETS.

	Montreal	Toronto
Sheets, Black, No. 28	\$6 25	\$6 75
Sheets, Black, No. 10 6 50		6 50
Canada plates, dull.		
52 sheets	7 00	7 00
Canada plates, all bright	8 00	8 00
Apollo brand, 10½ oz. galvanized	7 25	7 25
Queen's Head, 28 B. W.G.	7 75	7 75
Fleur-de-Lis, 28 B.W. G.	7 45	7 35
Garbal's Best, No. 28	8 25	7 50
Colborne Crown, No. 28	8 00	6 75
Premier, No. 28 U.S.	7 75	7 95
Premier, 10½ oz.	8 00	8 25

PROOF COIL CHAIN.

¼ in.	\$9 45
5-16 in.	9 10
¾ in.	8 35
7-16 in.	7 15
1½ in.	6 95
3-16 in.	6 95
¾ in.	6 80
¾ in.	6 70
¾ in.	6 55
1 inch	6 40

Above quotations are per cwt.

ELECTRIC WELD COIL CHAIN B.B.

½ in.	\$15 50
3-16 in.	11 70
¾ in.	8 40
5-16 in.	7 40
¾ in.	6 35
7-16 in.	6 35
½ in.	6 35
¾ in.	6 35
¾ in.	6 35

Prices per 100 lbs.

FILES AND RASPS.

	Per Cent.
Great Western, American	60
Kearney & Foot, Arcade	60
J. Barton Smith, Eagle	60
McClelland, Globe	60
Whitman & Barnes	60
Black Diamond	50
Delta Files	47½
Nicholson	50
Globe	57½
Vulcan	57½
Disston	60

COAL AND COKE.

Solvay Foundry Coal	
Connellsville Foundry Coal ..	
Yough Steam Lump Coal ..	8 50
Pittsburgh Steam Lump Coal ..	8 50
Best Slack	9 00
Net ton f.o.b. Toronto	

BOILER TUBES.

Size.	Seam- less	Lap- welded
1 in.	\$24 00
1¼ in.	30 00
1½ in.	32 00	25 00
1¾ in.	32 00	25 00
2 in.	35 00	26 00
2½ in.	44 00	33 00
3 in.	47 00	38 00
3½ in.	45 00
3¾ in.	59 00	48 00
4 in.	74 00	60 00

Prices per 100 feet, Montreal and Toronto.

OILS AND COMPOUNDS.

Castor oil, per lb.	27
Royalite, per gal., bulk	16
Palacine	19
Machine oil, per gal.	26½
Black oil, per gal.	13
Cylinder oil, Capital	45½
Cylinder oil, Acme	36½
Standard cutting compound, per lb.	6 15
Lard oil, per gal.	1 45
Union thread cutting oil antiseptic	68
Acme cutting oil, antiseptic	37½
Imperial quenching oil	39½
Petroleum fuel oil	12¾

BELTING—NO. 1 OAK TANNED.

Extra heavy, single and double	30-5%
Standard	40%
Cut leather lacing, No. 1	1 50
Leather in sides	1 35

TAPES.

Chesterman Metallic, 50 ft.	\$2 00
Lufkin Metallic, 603, 50 ft.	2 00
Admiral Steel Tape, 50 ft.	2 75
Admiral Steel Tape, 100 ft.	4 45
Major Jun. Steel Tape, 50 ft.	3 50
Rival Steel Tape, 50 ft.	2 75
Rival Steel Tape, 100 ft.	4 45
Reliable Jun. Steel Tape, 50 ft.	3 50

WASTE.

White	Cents per lb.
XXX Extra	20
Peerless	20
Grand	19
Superior	19
X L C R	18
Atlas	18
X Empire	18
Ideal	17
X press	16

COLORED.

Lion	14½
Standard	13
No. 1	13
Popular	11¾
Keen	10½

WOOL PACKING.

Arrow	25
Axle	20
Auvil	15
Anchor	11

WASHED WIPERS.

Select White	12
Mixed colored	10
Dark colored	09

This list subject to trade discount for quantity.

RUBBER BELTING.

Standard	50%
Best grades	30%

ANODES.

Nickel	.50 to .54
Cobalt	1.75 to 2.00
Copper	.44 to .46
Tin	.49 to .56
Zinc	.23 to .25

Prices Per Lb.

COPPER SHEETS.

	Montreal	Toronto
Bars, ½ to 2 in.	55 00	53 00
Plain sheets, 14 oz., 14x28 in., 14x60 in.	55 00	53 50
Copper sheet, tinned, 14x60, 14 oz.	60 00	54 25
Copper sheet, plain, 14x60 base.	64 00	60 00
Braziers', in sheets, 6x4 base	55 00	52 00

BRASS.

Brass rods, base ½ in to 1 in rd.	0 55
Brass sheets, 8 in. wide, 20 oz.	0 60
Brass tubing, seamless	0 57
Copper tubing, seamless	0 58

PLATING SUPPLIES.

Polishing wheels, felt.	2 10
Polishing wheels, bull-neck	1 35
Emery in kegs, American	06
Pumice, ground	04
Emery glue	15 to 20
Tripoli composition	04 to 06
Crocus composition	07 to 08
Emery composition	08 to 09
Rouge, silver	35 to 50
Rouge, powder	30 to 35

Prices Per Lb.

LEAD SHEETS.

	Montreal	Toronto
Sheets, 3 lbs. sq. ft.	\$16 00	\$16 00

Sheets, 3½ lbs. sq. ft.	16 00	16 00
Sheets, 4 to 6 lbs. sq. ft.	15 50	15 50
Cut sheets, ½¢ per lb. extra.		
Cut sheets to size, 1¢ per lb. extra.		

PLATING CHEMICALS.

Acid, boracic\$.15
Acid, hydrochloric05
Acid, hydrofluoric14½
Acid, nitric10
Acid, sulphuric05
Ammonia, aqua08
Ammonium carbonate15
Ammonium chloride11
Ammonium hydrosulphuret40
Ammonium sulphate07
Araenic, white12
Copper, carbonate, anhy.35
Copper, sulphate17
Cobalt sulphate70
Iron perchloride20
Lead acetate16
Nickel ammonium sulphate12
Nickel carbonate35
Nickel sulphate15
Potassium carbonate75
Potassium sulphide (substitute)20
Silver chloride (per oz.)65
Silver nitrate (per oz.)55
Sodium bisulphite10
Sodium carbonate crystals05
Sodium cyanide, 127-130%41
Sodium hydrate04
Sodium hyposulphite, per 100 lbs. 5.00
Sodium phosphate14
Tin chloride60
Zinc chloride60
Zinc sulphate09

Prices Per Lb. Unless Otherwise Stated.

The General Market Condition and Tendency

THE steady advance in prices of steel products continues without any indication whatever as to when the crest of the movement is likely to be reached. The probability that the United States Government will be a heavy buyer of steel has stimulated the demand and is tending to force prices up. The situation in the States is being reflected in the Canadian market and higher prices on all iron and steel products may be looked for. Conditions at the mills have improved and production is increasing in a satisfactory manner. The freight congestion has been relieved materially, allowing a freer movement of fuel and raw materials. Manufacturers are thus in a better position to increase their output, although the shortage of labor is still a handicap. Prices of pig-iron in the States continue to advance and higher prices on Canadian foundry irons are looked for in the near future. Shipments of coke are heavier, due to the improvement in the car situation and increase in output at the ovens. Prices of scrap metals are holding firm at unchanged prices. The demand is confined principally to steel scrap and machinery cast iron. Gasoline, benzine and coal oil have advanced, the market being very firm. The demand for non-ferrous metals is light, and prices are unchanged with the exception of antimony, which has advanced. The metal markets are quiet, due to the unsettled International situation. The machine tool market is quiet and situation unchanged.

Montreal, Que., April 2, 1917.—The outstanding feature of the present industrial situation is undoubtedly the meeting of the American Congress to dispose of the long drawn out action on the part of that government, regarding the part they are to play in the present world crisis. The effect of the United States entrance into the war will tend to increase the strenuous efforts that steel producers have been making to supply the needs of home and export demand. Additional pressure on the furnaces and mills can only have one re-

sult, that of a further advance to higher levels. The consistent demand for shell steel and the great difficulty experienced in obtaining raw materials have resulted in the constant rise in the cost of pig iron which must naturally be transmitted to the steel products, so that any additional pressure placed on the producing plants must necessarily mean a corresponding advance in prices together with increased difficulty in the delivery of supplies. The early opening of navigation is expected owing to the favorable weather conditions, assisted by the

activity of the government ice-breakers along the route of the St. Lawrence River.

Pig Iron

The upward movement in pig iron quotations continues and indications point to a still further advance. Bessemer heads the list this week with an advance on the Pittsburgh quotation of \$2 per ton, the price being now \$40.95 per ton. The latest advance brings the composite price of pig iron up to \$37.06 per ton. The higher tendency in the pig iron situation will likely influence early conditions in the steel market.

Steel

The dominating feature in the steel situation is the uncertainty that characterizes the American market owing to the tension on all sides as a result of the coming developments. Whatever action the government may decide on, it is certain to have a stimulating effect upon all industrial circles. Should a declaration of war be the outcome of the present sitting of Congress, and America decide to take an active part in subduing the enemy, great impetus will be given to a large number of industries, and steel will again take an upward bound. This will in all possibility only affect the present market, as the American producers will likely follow the action of the copper interests, in supplying the requirements of the government at a price somewhat below that prevailing on the open market.

It is believed that delivery to present customers will be somewhat delayed in order that the more urgent needs of the government can be filled. Canada may experience greater difficulty in obtaining

supplies from the States, and producers here should figure on increasing their facilities to meet the changed conditions. Although the congestion on the railroads is becoming less pronounced each day, there is still much room for improvement. The near approach of the opening of navigation will afford some relief in this direction, but the greatest drawback to maximum production of finished and semi-finished product, is the difficulty of producers to secure the raw materials, and the serious condition of the labor market, which in the event of war will still further add to manufacturing handicap. Few changes have been recorded in the general steel situation, but the further advance noted in this week's pig iron quotations, will likely be reflected in the early prices of various grades of steel. The demand for billets and sheet bars continues to be very heavy and the higher cost of basic metal may eventually mean still higher quotations on this grade of steel. Another factor tending to higher steel prices is the stronger position of ferroalloys; the price of ferromanganese for prompt delivery having advanced \$50 during the past week. The current quotation being \$375 per ton. Price on fourth quarter delivery is now \$300. Pressure on the plate mills reflects the future of this branch of the steel industry, one that will not be so easily affected by a sudden change in international relations. War possibilities would increase the tension under which these mills are working at the present time, while any easing up of hostilities would throw increased business toward the plate mills, in order to meet the ever increasing needs of the shipping interests. Canadian shipbuilders are making strenuous efforts to combat the tonnage question, by providing increased facilities for the production of vessels, but the greatest problem will continue to be the inadequate supply of plates for steel vessels. It is anticipated that the early future will bring about a revision in the price of sheets, as large producers are contemplating a move in this connection. The continued heavy demand for wire and its products may shortly mean a further advance in these lines; several sales are reported to have been made, at prices above those prevailing on the open market. Wrought iron pipe is still in heavy demand and definite delivery is practically impossible to obtain. Despite the recent advance in boiler tubes, the demand upon the mills is so insistent that users of these supplies are experiencing what might be termed a famine and even the offer of heavy premiums cannot induce the producers to satisfy the requirements of some customers. The sold up condition of the mills is such that definite delivery cannot be promised before the middle of next year. The local situation remains unchanged; the freight situation has become less serious but difficulty is still experienced in securing delivery of material.

Metals

The metal interests are anxiously

awaiting the action of the U.S. government, as their decision will greatly influence the early future policy of dealers and producers. The market generally has developed a weaker undertone with prices easier. Copper is responding to the quieting influence and quotations have declined. Tin continues to retain its average position with this week slightly easier than last. Spelter is dull and lower. Lead is firm but with a weak undertone. Antimony is stronger abroad but easier locally. Aluminum is steady and firm.

Copper.—Quiet prevails in the copper situation and the slackening off in the demand is principally due to the disturbed conditions arising out of the political movement in the United States. The tension is now at the breaking point and the present week promises some of the most interesting developments since the opening of hostilities. Whether the fact of the American Government securing copper at a figure greatly below the market price, will have the effect of producing an easier market, is at present problematical but the indications point to a decline in copper quotations. The London market has continued firm, but the situation in New York has shown a weaker tendency; lake having declined $\frac{1}{2}$ cent, and electrolytic one cent. Local dealers report a much easier position in copper with a slightly weaker demand; quotations show a falling off of $3\frac{1}{2}$ ¢ on lake and electro., and $4\frac{1}{2}$ ¢ on castings, the respective prices being $39\frac{1}{2}$ ¢ for lake and electro, and $38\frac{1}{2}$ ¢ for castings.

Tin.—While a weaker tone has developed in tin, the situation is nevertheless comparatively firm. The market is still influenced by the ever present possibility of loss in transit, and the unsettled condition across the line tends to put dealers on their guard, as early developments may create an unprecedented situation in industrial circles. Considerable interest is centered in the higher prices quoted on straits tin, and the possibility of a curtailment in the supply. Easier conditions prevail both in London and New York, the latter having declined $13\frac{1}{2}$ ¢ on the week, the current quotation being $54\frac{1}{2}$ ¢ per lb. The local situation has developed a weaker tendency on a quiet market, the quotation of $55\frac{1}{2}$ ¢ being a decline of one cent per lb.

Spelter.—Absence of interest has resulted in a dull market and an undertone of weakness seems to prevail, although what little business is passing is done at firm prices. The principal factor in the maintenance of present high prices is the zinc ore situation, which in many respects, is the controlling feature of the spelter market. Early future conditions will be governed to a great extent, by the developments of the next few days, when the action of the United States authorities has been definitely decided on. New York quotations this week are about $103\frac{1}{4}$ ¢ this price being $1\frac{1}{2}$ ¢ cent below that of the previous week. Dealers here report an easier

tone on a decline of $\frac{1}{2}$ cent per lb. the price asked being 15¢ per lb.

Lead.—The falling off in demand has somewhat weakened the lead situation, but the strength is being well maintained owing to sold up condition of the producers. This fact alone is the reason of the high market as the requirements of the trade at the present time are considerably below the production figures. Should the needs of the U.S. government necessitate supplies of lead, it is anticipated that metal will be supplied upon similar conditions to those furnished by the copper interests. The easier tendency is reflected in the slight decline of outside quotations, although the leading interests continue to hold firm. Trust price steady at 9¢, with independents quoting $9\frac{3}{4}$ ¢, this latter price being $\frac{1}{8}$ cent lower than last week. The local market continues firm with prices unchanged at $12\frac{1}{4}$ ¢ per lb.

Antimony.—The demand for this metal is very good and unexpected arrivals have had a contrary effect upon the situation, as dealers are apparently impressed with the higher value of spelter and consequently quotations have moved upwards. Conditions at the present time however, are such as to give no clear indications as to the near future, and the trade would not be surprised to see another reversal before the week closes. The current price of 36¢ on the New York market, shows an advance over last week of 2¢ per lb. On a weaker market dealers here are quoting 28¢ per lb., a decline of 2 cents over last week.

Aluminum.—The demand for aluminum is not heavy but the market continues to maintain its strength, the local quotation remaining firm at 70¢ per lb.

Machine Tools and Supplies

Activity in the machine tool industry is gradually assuming more general proportions and conditions, as the business that is passing is less of a shell nature than that of several weeks ago. A fair volume of business is still being done in single tools for munitions work, but even this has somewhat fallen off. A feature of the machine situation in the States is the anxiety that is displayed by tool builders, regarding the early effects that a declaration of war will have on this industry. While considerable used machinery is offered for sale, many firms equipped for shell making are apparently awaiting current developments before disposing of their equipment. War conditions will stimulate the production of machine tools, and result in a return to greater activity along these lines.

Scrap

The first part of the week was comparatively quiet in old metals, but the activity showed some improvement towards the close. Prevailing conditions tend to uneasiness in all branches of industries and that of scrap has been similarly affected. Local dealers in old material are awaiting the week's developments before adjusting their quotations. The changes this week are confined to

heavy melting steel and wrought iron axles; each having been marked up one cent per lb., the respective quotations being 17 and 22c per lb.

Toronto, Ont., April, 3.—The eminently satisfactory trade conditions now prevailing in Canada are clearly shown in a statement recently issued from Ottawa covering the revenue for the fiscal year which closed last Saturday. Although the exact figures are not yet available, the statement shows that the trade of the Dominion for the fiscal year just closed was approximately twice in value that of the preceding year. The ordinary revenue of the Dominion for the year just closed amounted to approximately \$230,000,000, or \$100,000,000 more than that of 1914-15.

Steel

The situation in the steel trade continues to get tighter, and prices are still going up. Recent reports of the steel companies all reveal the unusually satisfactory conditions prevailing in the industry, and indications point to continuance of prosperity for the remainder of this year at least. The improved weather conditions have been favorable to the transportation of raw materials and the situation in this regard is more satisfactory than at any time this year. Although the output of the mills has increased materially during the past two or three weeks, deliveries are not keeping up with orders, and consequently are getting further behind. The recent advance in wrought pipe in the States has been followed by a similar movement here. The advance is equivalent to about \$4 per ton and affects both black and galvanized pipe. Prices on boiler tubes are practically nominal as supplies are very scarce owing to the heavy demand and sold up condition at the mills. The demand for ship plates continues very heavy and indications point to the situation becoming more acute even in the near future. It is understood that the Imperial Munitions Board has placed orders for large tonnages of ship plates. Prices are practically nominal and substantial premiums are being paid for early deliveries, in fact the price depends largely on delivery required. The recent advance in price and growing scarcity of wire rods will doubtless result in higher prices on wire products in the near future. Advances in rivets, spikes, bolts and nuts may also be looked for in the near future.

Prices of Canada plates have advanced due to increase in cost of raw material. The demand for black sheets continues very heavy. Production on sheets is steadily increasing, but some mills are experiencing considerable difficulty in obtaining sheet bars, deliveries in consequence are generally backward. The situation in the galvanized sheet trade is improving, but there is no sign of lower prices.

The steel trade in the United States continues very active the volume of business being very heavy. The expec-

tation that the U.S. Government will soon be in the market for further heavy tonnages of steel is tending to stiffen prices. Open hearth sheet bars are now being quoted at \$72.50 per ton, and tank plates \$5.50 per 100 lbs. Pittsburgh.

Pig Iron

The pig iron market continues very strong and prices are still advancing in the States. The ruling price at Buffalo for foundry irons for current and last-half delivery is \$40 furnace, with a range of \$39 to \$40 from the lower to the higher grades. Prices on domestic foundry pig iron are unchanged at \$43, but an advance is looked for any time. A report from Pittsburgh states that enquiries are pending for from 10,000 to 20,000 tons of foundry iron for shipment to Canada. The following prices are now being quoted on leading grades of pig iron in the U.S. Grey forge, Pittsburgh, \$34.95; Lake Superior char-

CANADIAN GOVERNMENT PURCHASING COMMISSION

The following gentlemen constitute the Commission appointed to make all purchases under the Dominion \$100,000,000 war appropriation:—George F. Galt, Winnipeg; Hormidas Laporte, Montreal; A. E. Kemp, Toronto. Thomas Hilliard is secretary, and the Commission headquarters are at Ottawa.

coal iron, Chicago \$38.75; Basic Valley furnace \$35; Bessemer, Pittsburgh, \$30.95.

Scrap

The situation in old materials continues practically the same as last week. Prices although unchanged are holding firm. Interest centers principally on steel scraps which are in good demand particularly for heavy welding steel. Supplies of steel turnings are plentiful and are in excess of the demand. Copper, brass, and lead scrap, are in fair demand at unchanged prices.

Machine Tools

There is no appreciable change in the machine tool situation. There is still a fair demand for equipment for munitions plants, mostly for single tools. An aeroplane factory is in the market for machine tools which has helped to stimulate business. More second-hand equipment continues to come on the market from plants which have given up making munitions in the States.

Supplies

Gasoline, coal oil and benzine have advanced one cent per gallon, which brings gasoline up to 31½c per gallon, and benzine 1c lower. Coal oil, "Royalty," is 16c a gallon. Putty has ad-

vanced 25c and is now quoted at \$4 per 100 pounds in drums.

Metals

There is a quiet tendency in the metal markets due to a disposition to await developments in the International situation. The undertone however is firm and an upward movement in prices will likely develop now that the U.S. Government has decided to take an active part in the war. Prices are unchanged with the exception of antimony which has advanced due to a scarcity of this metal.

Copper.—The market is quiet and prices have an easier tone due to the appearance of re-sale copper on the market offered at concessions. Buying of copper for deliveries near the end of the this year is increasing. Prices are nominal and unchanged. Lake and electrolytic copper are quoted locally at 40c, and castings at 39c per pound.

Tin.—Prices of tin continue to be nominal, and the market is quiet although somewhat firmer. The London market has been advancing steadily for some days, but New York prices are unchanged. Tin is quoted locally at 56c per pound.

Spelter.—The market is dull but firm. Prices of spelter depend upon developments in the zinc ore situation, as the margin of profit is now very fine. A change one way or the other in the price of ore would likely be reflected in quotations on spelter. Local price is 14c per pound.

Lead.—There is no change in the lead situation and nothing to indicate any marked change in prices in the near future. Lead is quoted locally at 12¼c per pound.

Antimony.—Quotations are nominal and higher due to a scarcity of spot metal. Local price is 36c per pound.

Aluminum.—The market is dull and prices unchanged at 68c per pound.

Sydney, N.S., March 30. The Minister of Labor has declined to grant a Board of Conciliation on the application of the U.M.W. of Nova Scotia, purporting to represent a section of the workmen at the collieries of the Dominion Coal Co., for the reason that the question of a wage increase, which was given first place in the list of grievances preferred by the U. M. W. of Nova Scotia, was a matter already under discussion between the Dominion Coal Co., and its workmen as represented by the Provincial Workmen's Association. This last-named organization has entered into a wage contract with the company that does not expire until the end of 1918, and under the terms of this contract, the company granted a wage increase of six per cent. in May, 1916, to be followed by a further 4 per cent. increase on the 1st of January, 1917.

This last-named increase was, however, anticipated and made effective at the 1st of November last, and in addition the company granted a war bonus of ten per cent., making a total increase over the wages paid previous to May,

Enlarged Canadian Trade Intelligence Service

Under the arrangement made by the Minister of Trade and Commerce with Sir Edward Grey in July, 1912, the Department of Trade and Commerce, Ottawa, is able to present the following list of the more important British Consulates whose officers have been instructed by the Foreign Office to answer inquiries from and give information to Canadians who wish to consult them in reference to trade matters.

BRAZIL—Bahia, British Consul. Rio de Janeiro, British Consul General.	NETHERLANDS—Amsterdam, British Consul.
CHILE — Valparaiso, British Consul General.	PANAMA—Colon, British Consul. Panama, British Vice-Consul.
COLOMBIA — Bogota, British Consul General.	PERU—Lima, British Vice-Consul.
ECUADOR—Quito, British Consul General. Guayaquil, British Consul.	PORTUGAL—Lisbon, British Consul.
EGYPT — Alexandria, British Consul General.	RUSSIA—Moscow, British Consul General. Petrograd, British Consul. Vladivostok, British Consul. Odessa, British Consul General.
FRANCE—Havre, British Consul General. Marseilles, British Consul General.	SPAIN—Barcelona, British Consul General. Madrid, British Consul.
INDIA—Calcutta, Director General of Commercial Intelligence.	SWEDEN—Stockholm, British Consul.
ITALY—Genoa, British Consul General. Milan, British Consul.	SWITZERLAND—Geneva, British Consul.
MEXICO—Mexico, British Consul General.	URUGUAY—Monte Video, British Vice-Consul.
	VENEZUELA — Caracas, British Vice-Consul.

Canadian Commercial Intelligence Service

The Department of Trade and Commerce invites correspondence from Canadian exporters or importers upon all trade matters. Canadian Trade Commissioners and Commercial Agents should be kept supplied with catalogues, price lists, discount rates, etc., and the names and addresses of trade representatives by Canadian exporters. Catalogues should state whether prices are at factory point, f.o.b. at port of shipment, or, which is preferable, c.i.f. at foreign port.

CANADIAN TRADE COMMISSIONERS.

ARGENTINE REPUBLIC—H. R. Poussette, Reconquista, No. 46, Buenos Aires. Cable address, Canadian.
AUSTRALIA—D. H. Ross, Stock Exchange Building, Melbourne. Cable address, Canadian.
BRITISH WEST INDIES—E. H. S. Flood, Bridgetown, Barbadoes, agent also for the Bermudas and British Guiana. Cable address, Canadian.
CHINA—J. W. Ross, 13 Nanking Road, Shanghai. Cable address, Cancom.
CUBA—Acting Trade Commissioner, Lonja del Comercio, Apartado 1290, Havana. Cable address, Cantracom.
FRANCE—Phillipe Roy, Commissioner General, 17 and 19 Boulevard des Capucines, Paris. Cable address, Stadacona.
JAPAN—G. B. Johnson, P. O. Box 109, Yokohama. Cable address, Canadian.
HOLLAND—Acting Trade Commissioner, Zuidblaak, 26, Rotterdam. Cable address, Watermill.
RUSSIA—C. F. Just, Canadian Government Commercial Agent, Alexandriyskays, Ploshch 9, Petrograd. L. D. Wilgress, Canadian Government Commercial Agent, Bukhgozla Ulitza No. 4, Omsk, Siberia.
NEWFOUNDLAND—W. B. Nicholson, Bank of Montreal Building, Water Street, St. John's. Cable address, Canadian.
NEW ZEALAND—W. A. Beddoe, Union Buildings, Customs Street, Auckland. Cable address, Canadian.
SOUTH AFRICA—W. J. Egan, Norwich Union Buildings, Cape Town. Cable address, Cantracom.
UNITED KINGDOM—Harrison Watson, 73 Basinghall Street, London, E.C., England. Cable address, Sleighbing, London. N. D. Johnston, Sun Building, Clare Street, Bristol. Cable address, Canadian. J. E. Ray, Central House, Birmingham. Cable address, Canadian. J. Forsyth Smith, 27-28 Pearl Building, East Paradise, Leeds. Cable address, Canadian. F. A. C. Bickerdike, Canada Chambers, 36 Spring Gardens, Manchester. Cable address, Cantracom. J. T. Lithgow, 87 Union Street, Glasgow, Scotland. Cable address, Cantracom.

SPECIAL TRADE COMMISSIONER—LUMBER

H. R. McMillan, visiting Europe, Africa, Australasia and the Orient.

CANADIAN COMMERCIAL AGENTS

AUSTRALIA—E. Millin, Exchange Building, Sydney, N.S.W.
BRITISH WEST INDIES—Edgar Tripp, Port of Spain, Trinidad. Cable address, Canadian. R. H. Curry, Nassau, Bahamas.
NORWAY AND DENMARK—C. E. Sontum Grubbegeed No. 4, Christiansia, Norway. Cable address, Sontums.

CANADIAN HIGH COMMISSIONER'S OFFICE

UNITED KINGDOM—W. L. Griffith, Secretary, 17 Victoria Street, London, S.W., England. Cable address, Dominion, London.

1916, of 21 per cent. Further, and in addition, the company granted a bonus of 5 per cent. to all producers who worked 22 days out of each working period of 24 days, with a view to encouraging production. This brought the wages of producers up to 26½ per cent. above those of May, 1916. The P. W. A. have now preferred a request for a further 30 per cent. increase, which, if granted would make wages 57 per cent. above those of May, 1916, and in the case of those who earned the steady work bonus, would represent an increase of no less than 65 per cent. The Coal Co. have refused to grant an increase of such magnitude, and it is understood the P. W. A. have asked for a Board of Conciliation, which, in view of the decision of the Minister of Labor in the case of the U. M. W. of Nova Scotia, will in all probability be granted.

The Minister of Trade and Commerce has called a meeting on the 2nd of April at which the attendance of the coal operators of Nova Scotia is asked to consider the question of coal supply and transportation. It is not generally realized how great a change has taken place in the percentages of distribution of Nova Scotian coal as compared with pre-war times. Before the war the quantity of coal used at the steel works in Cape Breton, in colliery consumption, local domestic sales and supplied at home ports to steamer bunkers, would average 30 per cent. of the coal production. To-day the coal consumed locally amounts to 65 per cent. of the total production of the collieries.

As an example of the reversal of some of the figures it may be stated that in 1914 the shipments of the Dominion Coal Co. to the St. Lawrence markets represented 44 per cent. of the total disposal of the company's production. In 1916 the St. Lawrence percentage had dropped to ten per cent., and in 1917 it may not exceed 3 per cent. There is no way by which the production of the Nova Scotia coal mines can be increased except by bringing the miners back from the front, and the only way in which the continuous decline in production can be stopped is to prevent any further enlistment of miners. The normal coal production of Nova Scotia should be 7¼ million tons per annum. In 1917 the production will be between 5½ and 5¾ million tons, provided no accidents or stoppages of work take place. Government action in this matter is long overdue.

Construction work will very shortly be commenced on new coke-ovens for the Dominion Iron & Steel Co. at Sydney. It is understood the contract for the erection of the ovens has been let.

The Jones Underfeed Stoker Co., have removed their office from the National Trust Building King street, East, to 41 Britain street, Toronto with increased facilities for catering to the requirements of their customers.

GOULD & EBERHARDT

HIGH-DUTY SHAPERS

are what you need
for that heavy job,

and you can
have them

IMMEDIATELY.

20 in. and 24 in. Sizes

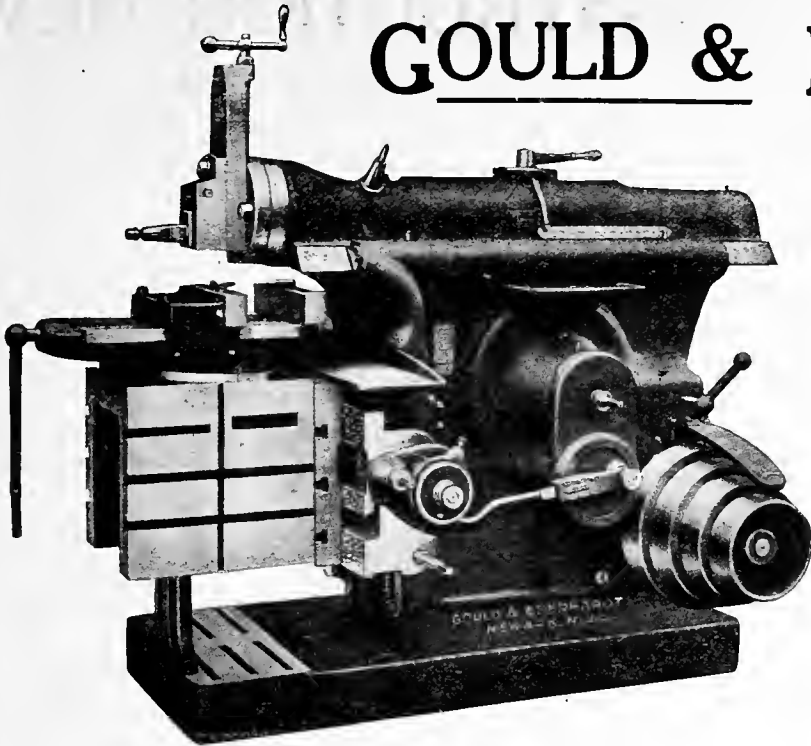

A. R. WILLIAMS MACHINERY CO., LIMITED

ST. JOHN, N.B.
WINNIPEG
VANCOUVER

"If It's Machinery, Write Williams."

64 Front Street West,
TORONTO - ONT.

"The Die Head That Thinks"

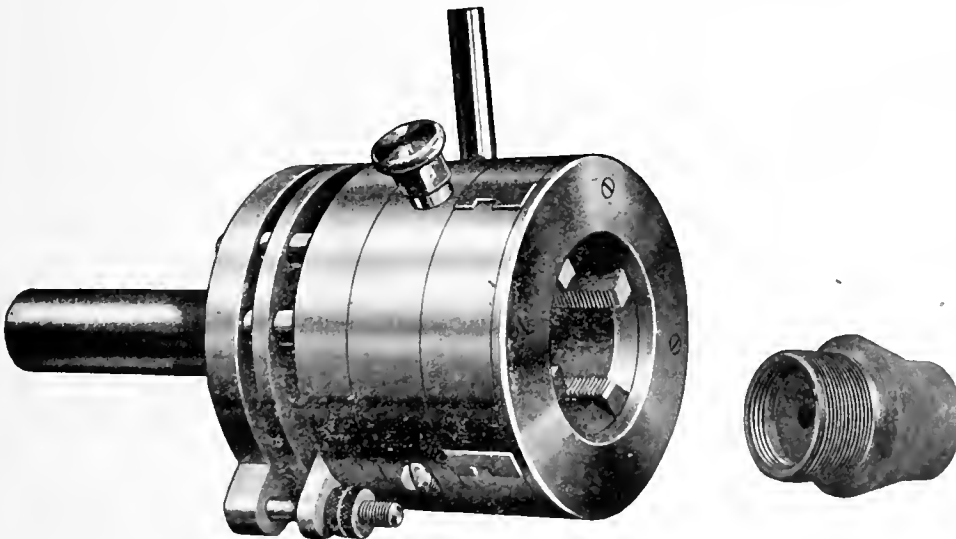

GEOMETRIC STYLE "D-D"

With such precision does the Geometric Style "D-D" Die Head perform every action, it has been called the Die Head that thinks.

Compensating springs give perfect threads at the start, and cause the dies to follow the lead properly. The head will float in either direction. On heavy turrets it is not necessary for the operator to follow the thread closely. Fine adjustments can be made for length right in the Die Head itself, without changing the stop on the machine.

The Style D-D Die Head illustrated above is cutting a 2-inch, 14 thread on fuse plugs, on a hand-operated turret. Are you among the small minority of screw-thread makers who have not discovered Geometric advantage?

The Geometric Tool Company, New Haven, Conn., U.S.A.

Canadian Agents:

Williams & Wilson, Ltd., Montreal. The A. R. Williams Machinery Co., Ltd., Toronto, Winnipeg. St. John, N.B.

If any advertisement interests you, tear it out now and place with letters to be answered.

INDUSTRIAL ^A_N^D CONSTRUCTION NEWS

Establishment or Enlargement of Factories, Mills, Power Plants, Etc.; Construction of Railways, Bridges, Etc.; Municipal Undertakings; Mining News

ENGINEERING

London, Ont.—The Middlesex Mills Co., are building a boiler house at their plant here.

Regina, Sask.—The Standard Tractor Co. has secured a site on which a plant will be erected soon.

New Hamburg, Ont.—The Dominion Thresher Co. has taken over the plant of the Hamburg Thresher Co.

Smelter Junction, B.C.—The C. P. R. proposes to build a round-house, shops, etc., at Smelter Junction, B.C.

Lindsay, Ont.—The Boving Hydraulic and Engineering Co., are considering building an extension to their plant.

Kitchener, Ont.—The Canadian Consolidated Rubber Co., will build a machine shop here. The Austin Co., of Cleveland, O., are the engineers.

Toronto, Ont.—Plans have been prepared for a new foundry to be erected on Cherry Street by the Queen City Foundry Co., at a cost of \$12,000.

Toronto, Ont.—A building permit has been issued to the Cluff Ammunition Co., 28 Atlantic avenue for a temporary saw shop, \$1,000, and storage shed \$1,000.

Kitchener, Ont.—V. O. Phillips & Sons have started the erection of an addition to the plant of the Twin City Oil Co., for the manufacture of a gas-line pump.

North Bay, Ont.—The Temiskaming and Northern Ontario Railway Commission propose building here a mechanical coaling plant to cost \$27,000 and a machine shop extension, \$15,000.

Halifax, N.S.—A new company has been formed which will be known as the Halifax Steel Co., to take over the Nova Scotia Car Works. Louis N. Fuller of Halifax is the moving spirit in the new enterprise.

Toronto, Ont.—Good progress is being made on the new steel plant at Ashbridge's Bay. The pile drivers are preparing the site and the Hamilton Bridge Works have started erecting one of the buildings.

Windsor, Ont.—Goldman & Harris who proposed to establish a brass foundry here may build the plant in some other town as the City Council has raised the price of the site from \$850 to \$1150 per acre.

Bedford, Que.—High water in the river carried away the dam on March 26, causing considerable inconvenience to the Bedford Light, Co., Bedford Stove Co., and Corey Needle Co., who obtain their supply of light and power from this dam.

East Angus, Que.—The Brompton Pulp & Paper Co. are building a power

plant about five miles below the mill. The power will be used to increase the capacity of the mill and replace some steam power being used at present. The cost of the development is estimated at \$200,000.

Fort William, Ont.—Mayor Murphy announced at the council meeting recently that the Canadian Car & Foundry Co. would operate their plant here, this spring. W. S. Attwood had just completed an inspection of the plant, which can be completed in ninety days, and partially operated as soon as material can be brought here.

Windsor, Ont.—Fire of unknown origin last Friday night completely destroyed the Canadian plant of the Chalmers Motor Co., located in Ford. The loss is placed at a quarter of a million dollars, fully covered by insurance. The Chalmers' plant, a branch of the parent concern in Detroit, was established about seven months ago.

GENERAL

Wallaceburg, Ont.—The Dominion Glass Co., will build an extension to their factory.

Montreal, Que.—The Imperial Tobacco Co., will build a large extension to their factory here.

Moose Jaw, Sask.—The Robin Hood Milling Co., will build an extension to their mill here.

Niagara, Falls, Ont.—The Perfection Tire Co. of Chicago, Ill., contemplate building a factory here.

Hamilton, Ont.—The Furnival-New Co., jam manufacturers, will build an extension to their plant, to cost \$5,000.

Toronto, Ont.—The manufacturing building at 35-45 Lombard street was damaged by fire on March 27 to the extent of \$30,000.

Petrolia, Ont.—The work on the flax mill, which was partly built last year, has been resumed and will soon be completed. Contracts for flax are being made with farmers.

Winnipeg, Man.—Charles Midwinter, land settlement agent of the Greater Winnipeg Water District, plans to develop extensively the sugar beet industry along the Shoal Lake Railway this season.

Markham, Ont.—At the recent fire at W. & G. Pringle's wagon works the plant destroyed at a loss of \$5,000, after receiving about \$1,000 insurance. It is not expected that the wagon works will be rebuilt.

Wallaceburg, Ont.—A new canning factory of the Ontario Cannery is expected to start here to be run six months of the year. The factory, which is close to the Pere Marquette station,

will be the head office of the Ontario Cannery.

North Bay, Ont.—The Town Council has decided to submit a by-law to the ratepayers authorizing the guaranteeing of bonds for the sum of \$15,000 to the J. P. Quinlan Manufacturing Co. The concern intends to manufacture furniture, school and church fittings, etc.

Guelph, Ont.—The firm of Fried, Grill & Co., of Toronto, hat manufacturers, have decided to locate here. The factory they will occupy is the one at present occupied by Libby, McNeil and Libby, and which is the property of the city. They have paid \$2,000 and the city takes a first mortgage of \$6,000 for the balance.

MUNICIPAL

Sidney, N.S.—The City Council may purchase fire alarm boxes, and motor driven fire equipment.

Trenton, Ont.—The Town Council have under consideration an extension to the water supply system.

Peterboro, Ont.—The City Council contemplate the purchase of combined motor-driven pumping engine and hose wagon.

Hamilton, Ont.—The Board of Control will buy a motor tractor and pump for the fire department at a cost of \$12,000.

Redcliff, Alta.—An expenditure of \$30,000 is contemplated for alterations in the present pumping station and installation of adequate machinery. A by-law will be submitted to ratepayers.

Sherbrooke, Que.—The by-law submitted to the rate-payers on March 26, providing for the purchase of the Two Miles Falls power plant on the St. Frances River at Weedon, at a cost of \$375,000, was carried by a large majority.

Wiseley, Sask.—A by-law will be submitted to the ratepayers on April 7 to authorize an expenditure of \$9,000 for the purchase of a gas engine, dynamo, building and site, etc., for municipal electric light plant. A. B. Hill, secretary-treasurer.

Sudbury, Ont.—On April 30 a by-law will be voted on by the ratepayers to sanction an expenditure of \$46,000 for stand pipe and auxiliary main, and \$2,500 for alterations to lake sewer pumping station. W. J. Ross, town clerk.

Hilldale, Ont.—A by-law will be voted on by the ratepayers on April 16 to authorize an expenditure of \$2,500 to purchase and instal a gasoline engine and appliances for supplying electric light in the police village of Hilldale. T. D. Robinson, township clerk, Moonstone, Ont.

Aikenhead's

RADBORE HEAD

**Drills Square Holes
Accurate**

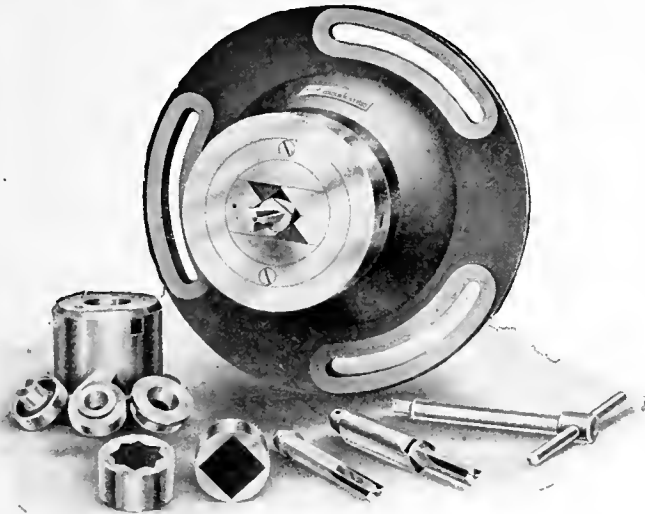

MAXIMUM ACCURACY--MINIMUM COST

Radbore Heads will drill square holes through the material or they will drill square holes to any desired depth with perfectly flat bottoms! Once in your shop the uses that spring up for this head will be remarkable.

Aikenhead Hardware Limited

17, 19, 21 TEMPERANCE STREET, TORONTO

Aikenhead's **New Chuck**

Did you know that the tang was unnecessary?

See the Broken Tang

See the Broken Tang

Perhaps you are about to discard some taper shank drills because the tangs are broken off—don't do it—they are worth their weight in gold. You can use them just as they are with a

Wahlstrom Automatic Chuck

For Nos. 1, 2 or 3 M. T. Shank Tools

and you won't have to take time from your production to repair them.

Tool changes are made in two seconds—just grasp the shell of the chuck with one hand and put in or remove the tool with the other—no collets—no lost time, for the spindle never stops.

The jaws hold not the tang, but the entire shank—there's no chance for slippage—a Wahlstrom won't even mar the shanks.

There are also three sizes of Wahlstroms adapted for straight shank tools—have you heard the story? Better write for it to-day and we'll explain our trial offer.

Aikenhead Hardware Limited

17, 19, 21 Temperance Street

Toronto, Canada

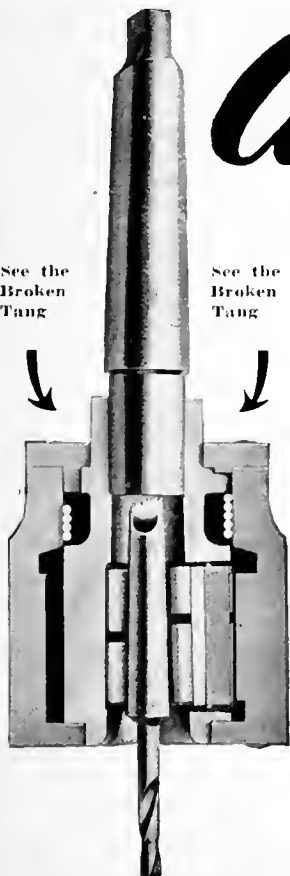

"Barnes-Made" SPRINGS

are unusual in
service and wear

They are the result of
sixty years' experi-
ence, unsurpassed
equipment and highly skilled work-
manship.

A trial will convince you that
"Barnes-Made" Springs are the
best buy.

Established 1857

THE WALLACE BARNES COMPANY
218 South St., Bristol, Ct., U.S.A.

Makers of "Barnes-made" Products
Springs, Screw Machine Products, Cold Rolled Steel and Wire



"HAWK" D CHROME VANADIUM STEEL



Will
Give You
Exceptional

Shell Forging Production

WITHOUT AN EQUAL FOR
BOTH FIRST AND
SECOND OPERATION
PUNCHES.

Comes to you heat-treated
and ready for use.

It does not stick to the
work.

There are many cases where
each punch has turned out
over 2,000 shells.

It means more shells, per
machine per day.

STEEL OF EVERY
DESCRIPTION.

Hawkrige Brothers Company

303 Congress St., BOSTON, MASS.
U. S. A.

ELECTRICAL

St. Catharines, Ont.—The Hydro-Electric Commission of St. Catharines have decided that in order to give the residents of this city the best possible service a new line must be built to the city from Niagara Falls. This line will be started immediately.

TENDERS

Regina, Sask.—The City Council are receiving tenders for a centrifugal pump and motor.

Terrebonne, Que.—The Town Council are calling tenders for a shoe factory. The plans and specifications of this building can be seen in the office of Dupont Roy & Beaudoin Engineers, 225 St. James Street, Montreal.

Montreal South, Que.—Tenders will be called sometime in April, for a 30-h.p. motor-driven turbine pump and a 150-h.p. gasoline engine-driven turbine pump for fire purposes, etc. E. Drinkwater, St. Lambert, Que., is the engineer.

Toronto, Ont.—Tenders will be received for a building until April 9, addressed to the Toronto Harbor Commissioners, 50 Bay Street, Toronto, Ont. All information may be obtained by applying to the Architects, Chapman and McGiffin, 95 King Street East, Toronto.

Greenfield Park, Que.—Tenders will be received until April 12 for the following:—Copper wire, transformers, street brackets, tungsten lamps, line construction material, meter. Specifications may be obtained on application to W. G. H. Cam, 3 Beaver Hall Square, Montreal.

Toronto, Ont.—Tenders will be received by Frank Barker, Engineer for the Township of York, up to April 14, for the supply and delivery of 24-inch stop valves and hydrants. Plans and specifications may be seen, and all necessary information obtained, at the office of the engineer, 57 Adelaide Street, East, Toronto.

Winnipeg, Man.—Tenders, addressed to the Chairman, Board of Control, will be received up to April 16, for the supply of labor and materials required in the erection of a 150 foot brick or concrete chimney for the Elmwood Incinerator. Plans, specification and form of tender may be obtained at the office of the City Engineer, 223 James Avenue.

Winnipeg, Man.—Tenders addressed to the Commissioners of the Greater Winnipeg Water District will be received up to April 16, for the supply of miscellaneous bronze castings, brass piping, etc., which enter into the construction of a Venturi meter. Specifications and form of tender may be obtained at the offices of the district, 501 Tribune Building, Winnipeg.

Winnipeg, Man.—Tenders addressed to R. D. Waugh, Chairman of the Commissioners, Greater Winnipeg Water District, up to April 16, for the supply of approximately 12,000 feet of 48-inch and 1,300 feet of 60-inch cast iron pipes,

together with numerous specials and gate valves. Specifications may be obtained upon application to the offices of the District, 501 Tribune Bldg., Winnipeg.

Winnipeg, Man.—Tenders, addressed to the chairman, Greater Winnipeg Water District Commission, at 501 Tribune Building, Winnipeg, will be received up to April 16, for the supply of one second-hand passenger coach, also one second-hand caboose, both standard gauge. Tenderers to supply own specifications. Further particulars on application to undersigned. R. D. Waugh, Chairman of Commissioners.

Ottawa, Ont.—Tenders will be received until April 21, for steam boilers and stokers required for the Central Heating Plant for the Parliament Buildings. All tenders to be based on the supplying and erecting of three water tube boilers, each having a rated capacity of 500 horse power, together with fittings and soot blowers. Each tender shall give separate quotations for supplying and erecting, in connections with boilers, three automatic stokers. One boiler and stoker shall be erected complete within five months after date of awarding contract and the other two shall be erected before January 1st, 1918. Plans, specifications and any other information required can be obtained at the office of the general contractor, P. Lyall & Sons Construction Co., Ltd., Ottawa.

CONTRACTS

The Phoenix Bridge & Iron Works, Montreal, have been awarded the contract for steel work for the \$45,000 steel bridge across St. Francis River at East Angus, Que.

The Rcelofson Elevator Works, Galt, Ont., have been awarded the contract for elevator equipment for the two-storey addition to the factory of the Gummed Paper Co., at Brampton, Ont.

Windsor, Ont.—The contract for the new bridge on Wyandotte Street over the M. C. R. has been awarded to J. V. Gray & Co. for \$14,730. Other bidders were: Wells & Gray, \$15,030; R. Westcott, \$17,279.

PERSONAL

W. F. Tye, of Montreal, has been engaged by the city of Hamilton, Ont., to report on a common railway terminus. Mr. Tye will start work at once.

Capt. E. T. Sterne, of Brantford, Ont., has been appointed chief inspector and resident technical adviser to the Imperial Munitions Board at the new plant of the British Chemical Co., Trenton, Ont.

James A. Stairs, vice-president of the Eastern Steel Co., New Glasgow, N.S., has recently been in Ottawa on a business trip, more particularly in the direction of securing orders for shipbuilding which his company propose to undertake.

Charles H. Waybrant, who for the past six years has been with the Steel

ILLINOIS

HOBS

PRODUCE PERFECT THREADS

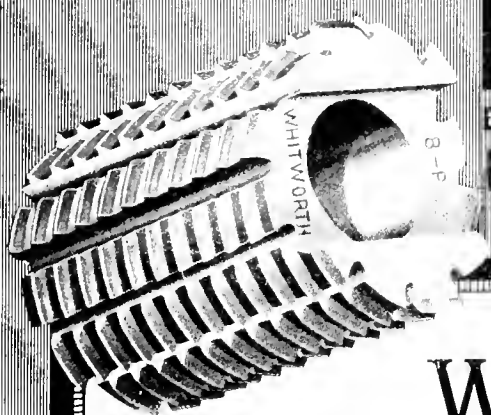

WHY not add the efficiency of ILLINOIS Tools to your equipment? ILLINOIS Hobs and Cutters can be relied upon for uniform accuracy and maximum output; they are of substantial advantage to the factory running to capacity in the production of work which must meet exacting specifications.

It will pay you to consult our specialists regarding thread milling hobs. Standard tools in stock; prompt delivery on specials. Write or wire for quotations.

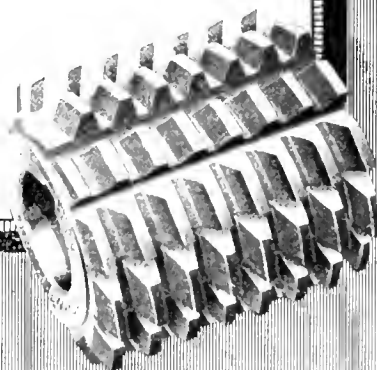

ILLINOIS TOOL WORKS

MANUFACTURERS AND DESIGNERS OF
CUTTERS · HOBS · REAMERS
 CHICAGO U.S.A.



CANADIAN REPRESENTATIVE: Allan B. Wearing, Canadian Pacific Railway Building, Toronto

If any advertisement interests you, tear it out now and place with letters to be answered.

PATENT ATTORNEYS

BABCOCK & SONS

ESTAB. 1872

PATENTS—TRADE MARK—DESIGNS
 IN ALL COUNTRIES

Book "Patent Protection"—free. Master of Patent Laws. Formerly Patent Office Examiner.
 99 St. James St., - Montreal, Que.
 Branches: Ottawa, Washington.

RESEARCH BUREAU

REPORTS BY EXPERTS ON SCIENTIFIC, TECHNICAL AND INDUSTRIAL DEVELOPMENT.

SPECIAL RESEARCHES ARRANGED.

PATENTS, TRADE MARKS, ETC.

 HANBURY A. BUDDEN CABLE ADDRESS
 712 DRUMMOND BLDG., MONTREAL "BREVET"

PATENTS

Fetherstonhaugh & Co.
 Patent Solicitors, Head Office,
 Royal Bank Bldg., Toronto,
 Ottawa Office, 5 Elgin St.
 Send for our Plain Practical
 Pointers. Copy of National
 Progress, in which our patents
 are advertised, mailed free.

PATENTS PROMPTLY SECURED

In all countries. Ask for our Investor's Adviser, which will be sent free.

MARION & MARION, 364 University St.
 Merchants Bank Building, corner
 St. Catherine St., MONTREAL, Phone Up. 6474
 and Washington, D.C., U.S.A.

SPECIAL MACHINERY

 GAUGES, FIXTURES, DIES
 AND
 PRECISION TOOLS

 WE HAVE THE
 MOST MODERN
 EQUIPMENT
 TO HANDLE
 ANY CLASS OF WORK

 CANADIAN DISTRIBUTORS FOR THE
**ALBANY PATENT ROTARY
 PUMP**
Albany Pump Co.

 16 Pearl St., TORONTO, Canada
 Phone Ad. 2511 A. W. Bennet, Manager

Company of Canada, at the Toronto office, has joined the staff of Baines & Peckover, iron and steel merchants, 98 Esplanade E., Toronto.

Hugh Russel, a life-long resident of Montreal, died on March 22 at his residence, 423 Guy street. Mr. Russel was president of Hugh Russel & Sons, Ltd., iron and steel merchants, Place d'Armes, and had been in business for himself in this city since 1868. He was born in Montreal on August 17, 1844.

Col. J. D. Stewart, who has performed useful service at the front, and has been placed in command of railway construction work for the allies in France, has also been promoted to the rank of brigadier-general. He is a well-known Canadian railway contractor, a member of the firm of Foley, Welch & Stewart.

Charles H. Easson, vice-president of Brown's Copper and Brass Rolling Mills, Ltd., formerly manager of the Toronto branch of the Bank of Nova Scotia has been appointed general manager of the Standard Bank of Canada, to fill the vacancy caused by the death of the late George P. Scholfield. Mr. Easson will assume his duties on April 2.

Dr. David H. Browne, widely known throughout the United States and Canada as a metallurgist of note, died at his home in Montclair, N.J., on March 30. He was 52 years old. In 1891 he joined the forces of the newly-organized Canadian Copper Co., and it was in the service of this concern that he brought about great improvement in the refining of metals and added much to the knowledge of metallurgy in this country and in the world. Dr. Browne was a member of the Canadian Mining Institute and many other engineering societies.

BUILDING

Toronto, Ont.—A building permit has been issued to the Wm. Neilson Co. for a warehouse to cost \$3,295.

Toronto, Ont.—City Architect Pearse has issued a building permit to the Dominion Glass Co. for a \$5,000 addition to their factory at the foot of Dovercourt road.

Windsor, Ont.—Gilbert Jacques, architect, is working on plans for a new service and sales building for the Studenbaker Corporation, which will be erected at the corner of Chatham and Pelissier. It will be a three-story structure of brick, steel and concrete, 50 by 80 feet. The building will be fireproof, and will cost about \$30,000.

MARINE

Montreal, Que.—Extensive improvements at the Canadian Vickers shipyard are now approaching completion. New berths and other extensions which have been undertaken at an estimated cost of \$1,000,000, are expected to be entirely completed by May 15.

Victoria, B.C.—The auxiliary schooner Laurel Whalen was launched at the

Cameron Genoa Mills shipyard on March 24. The christening ceremony was performed by Miss Marjorie L. Brewster, daughter of Hon. H. C. Brewster, Premier of British Columbia.

Collingwood, Ont.—During last week a fire broke out in the Northern Navigation Co's. steamer Germanic, which was burned to the water's edge. The Germanic was a wooden steamer, and was built in 1899. She was 184 feet in length, 23 feet beam, and 12 feet in depth.

Halifax, N.S.—An Act for the encouragement of shipbuilding in Nova Scotia has been introduced in the Legislature. The bill authorizes the appointment of a commission to investigate the existing facilities for building ships and manufacturing industries incidental thereto.

Montreal, Que.—Lachine Canal officials will shortly be very busy preparing for the opening of navigation. On April 7, the water will be run off, and a thorough inspection made of the canal bottom and lock structures. This will probably occupy a week, and it is the intention to admit the water again on April 15, in time for the opening of navigation.

TRADE GOSSIP

The E. J. Woodison Co., foundry outfitters have moved from 340 Dufferin street to more commodious premises at 858 Dupont street, Toronto.

Russians Buy Freighter on Great Lakes.—The steamer Nevada of the Goodrich Line, built at a cost of \$275,000 in 1916 to carry passengers between Milwaukee and Chicago and equipped for winter traffic with ice-breaking bows, was recently sold to representatives of the Russian Government for \$750,000. It will be used in the freight trade to Russian ports. The steamer will go to the Atlantic by the Welland Canal this spring and probably will be used to carry munitions to Russia.

Length of Freight Trains.—The Dominion Railway Commission has decided that under existing conditions it would not be justified in fixing a maximum length for freight trains. The commission on its own motion took up the question and heard the views of the railways and railway employees. Commissioner McLean, who writes the decision, holds that until the war is over the expeditious movement of freight should be the first consideration. When the war is over the question of regulating the length of trains will be taken up again.

Welland Canal Work Suspended.—Blasting on section 3 of the Welland Ship Canal to prevent the accumulation of water which has continued during the winter has been completed, and the Rock taken to Port Weller to hold the earthen breakwater embankment in place. Work on the big undertaking is now at a standstill, and will remain so until the end of the war. Thirteen locomotives owned by Baldry, Yerburgh & Hutcheson, contractors for section No. 2, have

been secured by the Government, and are to be sent to France for military construction work.

New Freight Schedule in Effect Shortly.—The time for filing objections to the new freight classification expired last Friday, and G. C. Ranson, Chairman of the Canadian Freight Association, says the railways will make every effort to bring the new classification, with such amendments as the Railway Commissioners may think proper to make, into effect as soon as possible. The classification has been in contemplation for a number of years, and railway officials have been working on it for two years and a half, the final draft having been sent to the Railway Commissioners, on July 15, 1916.

Australian Elevator Order for Montreal Firm.—The State of New South Wales is about to erect at various points throughout the State, approximately 200 wheat elevators. The cost of the whole scheme will be \$10,000,000. The Government of New South Wales has entered into arrangement with the well-known Montreal firm of John S. Metcalf & Co. to prepare a report, plans, and to supervise the work. The plans have been prepared by Metcalf & Co. at a cost of \$100,000, and the work of supervision is to be paid for at the rate of one and a quarter per cent. on the cost of the elevators—about \$125,000.

Will Launch Big Freighter.—Preparations have been completed for the launching to-day, Thursday at Collingwood, Ont., of the steel steamer Westmount, building for the Montreal Transportation Co. The Westmount is a sister ship to the J. H. G. Hazary, is 530 feet in length, has a beam of 58 feet and a depth moulded to 31 feet. She has a gross tonnage of 7,500 and will carry about 11,000 tons of cargo. It is expected that the Westmount will go into commission about May 1 and will operate on the Great Lakes between Fort William, Port Arthur, Georgian Bay ports, Port Colborne and Buffalo.

Canadian Westinghouse Co. Elects Officers.—At the annual meeting of the Canadian Westinghouse Co., held at Hamilton on March 27, the following elected to the directorate of the concern: H. H. Westinghouse, Hon. Lieut.-Col. Paul J. Myler, L. A. Osborne, Thomas Ahearn, Sir John M. Gibson, K.C.M.G., John F. Miller, C. F. Sise, Warren V. Soper, Charles A. Torry, Guy E. Tripp. The officers are: H. H. Westinghouse, chairman; Hon. Lieut.-Col. Paul J. Myler, president and treasurer; L. A. Osborne, vice-president; F. A. Merrick, vice-president and general manager; John H. Kerr, secretary; N. S. Braden, manager of sales.

The Turbine Equipment Co., Toronto, has been awarded a contract by the town of Strathroy, Ont., for one multi-stage De Laval centrifugal pump, which will be direct connected to a Canadian Westinghouse 125 h.p. motor; the capacity will be 1,000 Imperial gallons a minute, against 252 ft. total head. They have also been awarded through the Hydro-

**TRY HAMILTON
BABBITTS**
We Make Nothing Else
GEO. E. JOBBORN, Hamilton, Ont.

THE IRON WORKS
LIMITED
Successors to

Owen Sound Iron Works
Owen Sound, Ont.
Engineers
Boiler-makers
Founders
Machinists

Tank Work
Smoke Stacks,
Grey Iron and
Brass Castings,
Special
Machinery
Made to
Order



Tool Room Surface Grinder

Easily Adjusted, Strong, Accurate, Fast.

Has rigid grinding surface and large tray and water not combust. It's an unbeatable tool room surface grinder. Tell us your machinery wants experts on special designs. Satisfaction assured.

J. E. WING & SON, HAMILTON CANADA

OVENS

Enameling and Varnishing Ovens heated by Gas, Electricity, Steam or Coal. Write for Booklet.

Brantford Oven & Rack Co., Ltd.
Brantford, Canada.

MORTON MANUFACTURING CO.

PORTABLE PLANERS
DRAW CUT SHAPERS
SPECIAL DRAW CUT R SHAPERS
FINISHED MACHINE KEYS
STATIONARY & PORTABLE KEY WAY CUTTERS
SPECIAL LOCOMOTIVE CYLINDER PLANERS

OFFICE AND WORKS: MUSKEGON HEIGHTS U.S.A.

A PRICE PYROMETER makes it certain

Get a Record of Working Temperatures

Uncertainty is a time and effort waster—to be sure at a glance means efficiency. There is no "doubt," when you have a Price Pyrometer.

See that there is a Price Indicating Instrument within sight of every furnace in your heat-treating department. And have a Price Recording Pyrometer in your office to get a record of working temperature.

Let us send you our Catalogue and full particulars — How you can make it certain.

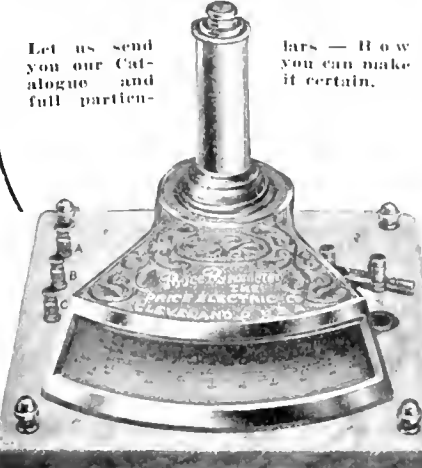

THE PRICE ELECTRIC CO.
12368 Euclid Avenue, CLEVELAND, OHIO

METAL STAMPINGS

We are manufacturers of stamped parts for other manufacturers.

We do any kind of sheet metal stamping that you require. Our improved presses and plating plant enable us to produce the finest quality of work in a surprisingly short time.

We can finish steel stamping in Nickel Brass or Copper.

Send us a sample order.

W. H. BANFIELD & SONS
372 Pape Avenue, Toronto, Can.

PURO

(MADE IN CANADA)

Every minute counts in getting maximum efficiency.

Our Puro Sanitary Drinking Fountains positively save 60% in drinking time, besides 35% of water ordinarily wasted. Can you afford to run your plant and lose and waste this money in old-fashioned drinking methods?

EFFICIENCY IS PATRIOTISM

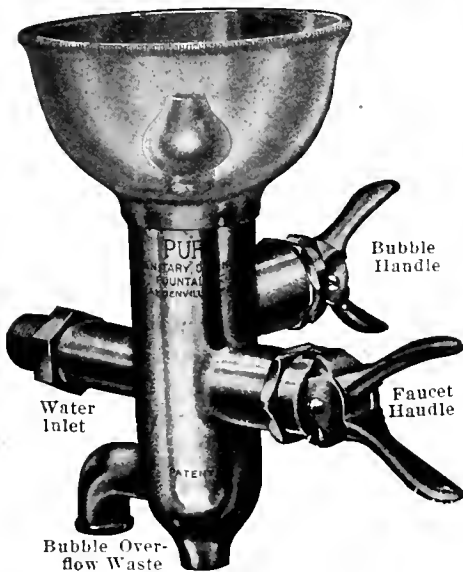

Ask your efficiency expert to figure this out and you will find that:

500 men drink, say, twice a day. Under old conditions it takes between 3 and 5 minutes per man, twice a day. With PURO cutting the time in half, it would save from 1,500 to 2,500 minutes per day at an average wage of 20¢ per hour. The saving would be from \$5.00 to \$8.50 per day.

How long would it take to pay for installing our fountains?

NOW IS THE SEASON TO THINK OF YOUR WATER PROBLEMS.

ASK OUR EXPERT ADVICE.

Puro Sanitary Drinking Fountain Co.
147 University Ave., TORONTO, CAN.

Opportunities!

You'll find opportunities galore in the Classified Advertising Section (pages 78-). Whether you're looking for a position, a lathe, drill shaper, a cupola, etc., you'll likely find listed there all you may need.

CANADIAN MACHINERY

Classified Advertising Section

143 University Ave., Toronto

Electric Power Commission of Ontario one De Laval single stage, centrifugal pump, which will have a capacity of 5,000,000 Imperial gallons a day against 210 ft. total head. This pump is for the City of Kingston, Ont., and will be direct connected to a 380 k.v.a. Canadian General Electric 1,200 r.p.m. synchronous motor.

Railway Commission Report.—The report of the commission on the Canadian railroad situation will be ready for Parliament soon after the reopening, April 12. It is generally understood Sir Henry Drayton and W. M. Akerworth, the English financial expert, favor the application of a degree of nationalization to the Canadian Northern and the Grand Trunk Pacific. The third member of the board, A. H. Smith, president of the New York Central, does not favor nationalization, but takes the view that the best interests of Canada will be served by keeping the C.N.R., the G.T.P. and the C.P.R. under separate corporate control competing with each other with rates and operation regulated by the railway commission.

Trade in Canada Almost Double.—Canada's fiscal year closed on March 31. Exact figures for its operations will not be available for a few days, but it may safely be stated that when they are published they will show the revenue of the Dominion in 1916-17 to have been the largest in its history. They will also show the trade of Canada to have been nearly twice that of 1914-15. The ordinary revenue of the Dominion, it is stated, on Saturday, amounted to about \$230,000,000, or \$100,000,000 more than that of 1914-15. The revenue of the past year will be sufficient to meet all the ordinary and capital expenditures of the country, and, in addition, pay fifty or sixty million dollars of the expenditures for war purposes. The total trade of the Dominion will be found to have reached about two billion dollars, or a billion dollars more than that of the fiscal year in which the war began.

Conference of Shipbuilders.—Sir George Foster, acting Prime Minister, held a conference at Ottawa on March 28, with the representatives of a number of Canadian shipbuilders, who are building ships in Canada for the British and Canadian Governments. The object of the conference was to discuss plans to systematize and speed up construction. The programme as already announced includes ships to the value of \$25,000,000 being built for the British Government under the authority of the Imperial Munitions Board, as well as a number of vessels being built for a Canadian Branch of the Government Service. The contractors are also to report to the Acting Prime Minister that good progress is being made although some difficulty has been encountered in procuring steel. It is understood, however, that this is being overcome. It is stated in this connection that another big British shipbuilding company is likely to establish a branch shipyard in Canada.

INCORPORATIONS

The Port Arthur Pulp & Paper Co. has been incorporated at Toronto, with a capital of \$2,000,000, to manufacture pulp and paper at Port Arthur, Ont. The incorporators are: George H. Sedgewick, James Aitchison and Duncan McArthur, all of Toronto.

The London Smelting & Refining Co. has been incorporated at Toronto, with a capital of \$45,000, to carry on the business of refiners and smelters of all kinds at London, Ont. The incorporators are: Jacob Harris, Samuel Harris, and Louis Harris, all of London, Ont.

The Bawden Pump Co. has been incorporated at Toronto, with a capital of \$40,000, to carry on the business of engineers and founders, including the manufacture of pumps of all kinds at Toronto. The incorporators are: G. H. Sedgewick, James Aitchison, and Duncan McArthur, all of Toronto.

RAILWAYS—BRIDGES

Montreal, Que.—The Merchants Bank of Canada has sent in an application at Ottawa to the Railway Commissioners for an order approving of the sale of the rolling stock, equipment, charter and other accessories of the Joliette & Lake Manuan Colonization Co.

Bloomington, Ont.—On March 24, representatives from the Kitchener City Council and from Guelph met a number of citizens of this locality, with whom they discussed the proposed Kitchener to Guelph via Bloomington and New Germany electric railway. The meeting was unanimous in favoring the scheme.

Montreal, Que.—New tenders have been called for by the Board of Control for the Lasalle bridge over the aqueduct, connecting Verdun with the city of Montreal. This action follows the withdrawal from his contract of T. O'Sullivan, who contracted to build the bridge in the first instance. In the meantime, pending the making of fresh bids, the city is holding Mr. O'Sullivan's deposit of \$25,000 which he made as security for fulfilling his contract.

WOODWORKING

Sarnia, Ont.—The Cleveland Sarnia Saw Mills opened on Monday after being closed since last fall, when logs were frozen in the bays. About 200 men have been put to work.

Elmira, Ont.—The Elmira Transmission Co. will erect dry kiln, moulding shop, and machine shop on Church St. A by-law will be submitted to the ratepayers to sanction a loan of \$15,000.

Winnipeg, Man.—R. Mackenzie, secretary of the Canadian Council of Agriculture, announced a few days ago that the Grain Growers' Grain Co. planned this year to build a lumber mill, costing practically \$150,000, upon a timber limit sixty miles east of Fort George, B.C., on the G. T. P.

CATALOGUES

Carbon Tool Steels.—Bulletin issued by the Vanadium-Alloys Steel Co., Pittsburgh, Pa., dealing with the various grades of "Vasco" carbon tool steel. Each grade is described briefly stating the class of work for which it is best suited. The bulletin gives a set of rules for the proper hardening of water hardening steels. A list of extras is also included.

The Britannia Foundry Co., Coventry, England, have issued a series of leaflets dealing with an interesting line of foundry equipment, including the "Britannia" and "Coventry" molding machines, the "Git" spruce cutter, sand mixers and drying stoves. Each machine is illustrated and described, while a specification is also included, giving the principal dimensions and other data.

Whiting Cranes.—Of all types and for every service are described and illustrated in catalogue 127 recently issued by the Whiting Foundry Equipment Co., Harvey, Ill. The opening pages of the catalogue deal with electric traveling cranes illustrating and describing the latest features in Whiting crane construction. Following are brief descriptions of hand power, locomotive and cranes accompanied by illustrations showing the various types. The second half of the catalogue shows several typical illustrations of whiting cranes of various sizes and capacities in different classes of service. These views represent a wide field of service covered and are shown with the object of assisting purchasers to select the proper types.

BOOK REVIEW

Handbook for Machine Designers, Shop Men and Draftsmen, by Frederick A. Halsey, B.M.E.; 561 pages; 11 x 8 in. Published by McGraw-Hill Book Co., New York. Second edition, price \$5.00 nett. The first edition of this volume appeared in 1913, being primarily an effort to rescue from the oblivion of the out of print, such contributions as are of direct use in the design of machinery. The standing of the author, as Editor Emeritus of the American Machinist was sufficient to guarantee the fulfilment of this original intention. As indicated, the book is a galaxy of selected contributions to the journal mentioned, and has been made up with a view to dropping old and introducing new material anywhere. In the short interval of three years, much matter has accumulated calling for an extensive revision: much of the matter now published is not readily accessible and some of it not in existence elsewhere. The subjects covered include shop and drawing office material which overlap to such an extent that the title was extended to include shopmen. The volume fulfills all of the requirements of a reference book, has all the conveniences of a pocket book, and possesses all the merits pertaining to original contributions by reputable authorities.

Subscriptions Invited From Friends Abroad

Canadian Machinery and Manufacturing News is published weekly. Representing, as it does, the industrial life and activities of Canada, it should prove of very considerable value to those who wish to buy Canadian products, and to those who may wish to sell in Canada.

As a technical journal it compares very favorably, we think, with any other high class publication, and will be found to be well worth the subscription price, and more.

If you are favorably impressed with this number, we think you will find other issues equally interesting. *Canadian Machinery* contains from eighty to one hundred and twenty pages—fifty-two issues in the year. We invite subscriptions from our friends abroad, and attach a coupon for the sake of convenience.

Subscription Order Form

To the Publishers,
CANADIAN MACHINERY,
143 University Ave.,
Toronto, Canada.

Gentlemen,—

You may enter our subscription to CANADIAN MACHINERY for one year, and until ordered discontinued, to be sent to address below. We enclose money order covering same.

Yours truly,

Name

Full address

City County.....

The subscription price to Great Britain and her colonies is 12s. 6d. United States, \$3.50, other countries 16/- per year.

Classified Advertising Section

Rates (payable in advance): Two cents per word first insertion; one cent per word subsequent insertions. Count five words when box number is required. Each figure counts as one word. Minimum order \$1.00. Display rates on application.

WANTED

WANTED - LATHE ABOUT 48" SWING or larger, also boring mill up to 60". Must be in good order and reasonable price. Apply Box 288, Canadian Machinery. c16m

FOR SALE

FOR SALE - AT A BARGAIN - 1-13/4" style D geometric die head, with extra dies. White Machine Works, Windsor, Ont. c16m

GAP LATHE, 28 x 42 x 16 FT. BED, FOR sale, cheap; also emery wheel stand, power hack saw. Guarantee Motor Co., Hamilton, Ont. (tf)

FOR IMMEDIATE SALE - 1-75 H. P. Elyria gas engine; 1-40 H.P. Elyria gas engine; 1-75 Kw., 250 volt D.C. Western Electric generator, belted type; 1-45 Kw., 250 volt D.C. Crocker-Wheeler generator, belted type; 1-45 H.P., 250 volt Westinghouse motor. All in first-class condition; can be inspected in daily use. The Elyria Machine Company, Elyria, Ohio. c14m

FOR IMMEDIATE SALE - THE FOLLOW- ing West Tire Setter Company handing presses: 1-9.2"; 1-6"; 1-3 1/4". All in first-class condition. Each been in use two months. The Elyria Machine Co., Elyria, Ohio. c15m

FOR SALE - ONE 450 H.P. THOMPSON & Williams condensing engine. Will sell cheap. Engine is in first-class repair and will give every satisfaction. Apply J. A. Marven, Limited, Moncton, N.B. tefm

ONE No. 2 WHITING CUPOLA, 36" SHELL capacity, one to two tons per hour. In perfect condition, used only for two heats. Address Purchasing Agent, Canadian Ingersoll-Rand Co., Ltd., Sherbrooke, Que. etmf

NEW BOILERS, CHEAP - 2 40 H.P. AND 1 50 H.P. open bottom, locomotive type boilers, complete with fittings for 125 lbs. working pressure. Can deliver from stock either east or west of Great Lakes. The Canadian Fairbanks-Morse Co., Ltd., 300 Princess St., Winnipeg, Man. c13m

FOR SALE - TWELVE PRACTICALLY new No. 7-C Racine Heavy Duty High Speed Hack Saw Machines. Suitable for all cutting purposes. Immediate delivery. For Price and further information address The Peck Rolling Mills, Limited, Montreal. c14m

ONE LATHE 16" x 4 1/2' back geared. Built by P. P. Silk Machine & Tool Co., Cincinnati, Ohio. One lathe 18" x 3', back geared. Built by the Bradford Mill Co., Cincinnati, Ohio. Four Murehey Collapsible Dies. Capacity 1 1/2" to 2 1/2". Box 272, Canadian Machinery. etmf

SPECIAL MACHINERY

MANUFACTURERS - WE CAN UNDER- take work to any specification—munition production equipment or otherwise. Write W. H. Sumbing Machinery Co., 7 St. Mary St., Toronto.

PATENTS

TAKE Notice that the Stanton Metallic Fur- niture Co., Limited, of the City of Toronto, Canada, duly manufactured the movable grate covered by Canadian Patent No. 101397, and that the Bennett & Wright Co., Limited, of the same city, duly manufactured the hot water heater covered by Canadian Patent No. 107120, prior to the period called for by the Patent Act, and on application to the undersigned any further orders for the two above inventions will be filed at a reasonable price. Ridout & Maybee, 59 Yonge Street, Toronto. Solicitors for Anders B. Reek.

Immediate Delivery

11-3/4" Gridley Single Spindle Automatics.

Fitted with 3" Modern Self-Opening Die Heads, complete with standard equipment.

Used Two Weeks. Good as New.
\$1500 Each.

Simmons Machine Co., Inc.

1001 Singer Bldg.
NEW YORK CITY

985 Broadway
ALBANY, N.Y.

And--- they're still coming in !

Twelve replies from as many first-class men to two insertions of a small ad. for a superintendent—and they're still coming in. Which merely proves what we've been saying right along—that Canadian Machinery goes to the right men—the men capable of filling the responsible positions.

Canadian Machinery

Classified Advertising Section

143 University Ave., Toronto, Ont.

SITUATIONS WANTED

SUPERINTENDENT - PRACTICAL MECH- anical man with 12 years' experience, last two years superintendent of shells, is open for a proposition. Box 289, Canadian Machinery. (c16m)

MECHANICAL ENGINEER WITH LONG experience designing and estimating on machine tools, special shell machinery, tools, jigs and fixtures, desires responsible position with well established company. Best of references given from well-known companies. Box 284, Canadian Machinery. c12m

SUPERINTENDENT WITH NINETEEN years' mechanical experience in manufacturing and repairing of machinery and structural steel, both shop and erection, desires change of position. Experienced in machining 18-Pr. and 4.5" high explosive shells. Aggressive character, good organizer, best of references. Box 282, Canadian Machinery. c12m

SUPERINTENDENT OR WORKS MAN- ager of large metal working plant desires change. Broad gauge man of modern methods and a producer of results. Over 20 years' experience at handling large forces of workmen in manufacture of high quality and interchangeable goods of brass, iron and steel. special tools, dies, machinery, etc. Includes brass works, machine shop, punching and stamping and fine brass work, taking entire control of plant. English-American descent. Box 280, Canadian Machinery. c15m

SITUATIONS VACANT

WANTED - MACHINERY SALESMAN TO handle Toronto and Western Ontario. Apply, giving experience to Box 285 Canadian Machinery. c14m

MECHANICAL ENGINEER WANTED - first-class opportunity for the right party. Must be energetic, ambitious, sober and have some knowledge of French. Apply Box 286, Canadian Machinery. tefm

MAN ABOUT 30, WITH ENGINEERING and commercial training, experienced in mine and smelter requirements, including structural and cast steel work. A man with office experience and capable of soliciting business preferable. Box 283, Canadian Machinery. c13m

EXPERIENCED TOOL MAKERS, SCREW machine hands and general mechanics wanted at once for new, well lighted plant (not munitions), situated just outside of Toronto; highest union wages and steady work for good men. Mention this paper. Canada Cycle and Motor Company, Limited, Weston, Ont. c13m

A GOOD SALES ENGINEER TO OPEN office to sell Moline Heat in Canadian territory. Must be a good salesman, having had a general heating and ventilating experience. Must give good references. We have a fine proposition for the right man. Address, Moline Heat, Moline, Ill. etmf

CANADIAN MACHINERY

AND MANUFACTURING NEWS

A weekly newspaper devoted to the machinery and manufacturing interests.

Vol. XVII.

TORONTO, APRIL 12, 1917

No. 15

EDITORIAL CONTENTS

Forging 4.5 ins., 60-pdr., and 6 ins. Howitzer Shell	363-365
Seasoning of Castings	365-366
General	366
British Munition Plants After the War.	
Production Methods and Devices	367-369
Milling Slots in Shell Noses....Angular Shell G it Cleaner Converting Square Feet into Square Inches....Machining Piston Rod Forgings on Hexagon Turret Lathe....Temperatures for Carbon Steels....Copper in Steel.	
Processes in Manufacture	370-372
Heat Treatment of Large Forgings.	
Spokes in Industry's Wheel	373
Robert Allan Gurnham.	
General	374
Paint and Ironwork....Trouble with Shaft Breaking.	
Steel Industry Developments	375-376
Cleaning Blast Furnace Gas....Electric Steels...By-Products Recovery	
Friction and Lubrication of Shafting	377-378
General	378
New Coal Washing Plant.	
Progress in New Equipment	379-380
Hydraulic Shingle Forming Press....Paint Gun Equipment ... Gigantic Voltage Regulator . Cycle Counter Timing Device....Spindle Drilling Machine.	
Editorial	381
A Post-War Problem of Labor.	
Selected Market Quotations	382-383
The General Market Condition and Tendency	383-386
Summary....Montreal Letter....Toronto Letter... American Shipbuilding Our Orders from Foreign Countries Grow.	
Industrial and Construction News	387-388

THE MACLEAN PUBLISHING COMPANY, LIMITED

JOHN BAYNE MACLEAN, Pres. H. T. HUNTER, Vice-pres. H. V. TYRRELL, Gen. Man.

Publishers of Hardware and Metal, The Financial Post, MacLean's Magazine, Farmer's Magazine, Canadian Grocer, Dry Goods Review, Men's Wear Review, Printer and Publisher, Bookseller and Stationer, Canadian Machinery and Manufacturing News, The Power House, The Sanitary Engineer, Canadian Foundryman, Marine Engineering of Canada.

Cable Address: Macpulco, Toronto; Atabek, London, Eng.

ESTABLISHED 1887.

CANADIAN MACHINERY AND MANUFACTURING NEWS

PETER BAIN, M.E., Editor. R. G. NEWTON, Manager.
Associate Editors: A. G. WEBSTER, J. M. WILSON, J. H. RODGERS.

CHIEF OFFICES:

CANADA—Montreal, 701-702 Eastern Townships Building; Toronto, 113-153 University Ave., Telephone Main 7324; Winnipeg, 22 Royal Bank Building, Telephone Garry 2315.

GREAT BRITAIN—LONDON, The MacLean Company of Great Britain, Limited, 88 Fleet Street, E.C. 4, E. J. Dodd, Director. Telephone Central 12960 Cable Address: Atabek, London, England.

UNITED STATES—New York, R. B. Huestis, 115 Broadway, N.Y., Telephone Rector 8971; Boston, C. L. Morton, Room, 733, Old South Building, Telephone Main 1201; A. H. Byrne, 11045-6-7 Fort Dearborn Bldg., 105 W. Monroe St., Chicago, Telephone Randolph 3234.

SUBSCRIPTION PRICE—Canada, Great Britain, South Africa and the West Indies, \$3.00 a year; United States, \$3.50 a year; other countries, \$4.00 a year; Single Copies, 15 cents. Invariably in advance.

HENDEY 18-inch GEARED HEAD LATHE

8 mechanical changes of speed for spindle with driving shaft running at constant speed, 4 direct and 4 through back gears.

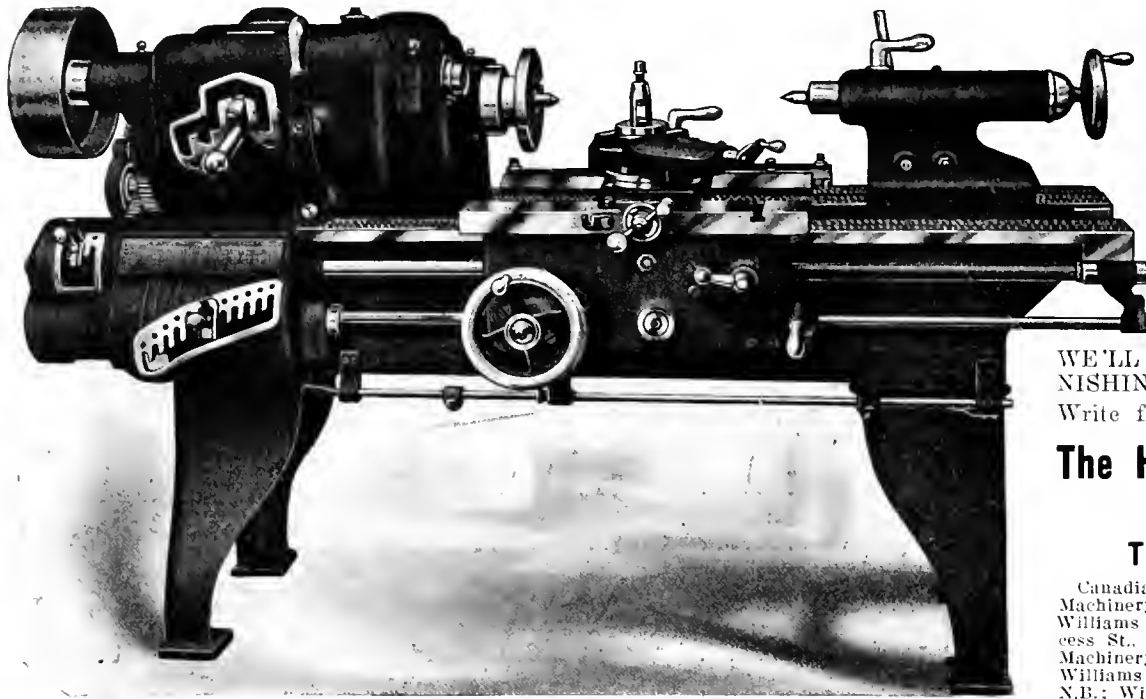

36 DIFFERENT THREADS AND FEEDS are had through Mounted Change Gearing, each change being quickly made through controlling handles in Gear Boxes.

BEFORE PURCHASING A NEW LATHE INVESTIGATE THE HENDEY SERVICE.

WE'LL HELP YOU BY FURNISHING LIST OF USERS. Write for descriptive circular.

The Hendey Machine Company Torrington, Conn.

Canadian Agents: A. R. Williams Machinery Co., Toronto, Ont.; A. R. Williams Machinery Co., 260 Princess St., Winnipeg; A. R. Williams Machinery Co., Vancouver; A. R. Williams Machinery Co., St. John, N.B.; Williams & Wilson, Montreal.

INDEX TO ADVERTISERS

A	D	K	Rhodes Mfg. Co. 97
Adams, Ogden R. 94	Davis-Bourmonville Co. 92	Kasent, Limited 15	Riverside Machy. Depot 68
Alhany Pump Co. 62	Davis, W. P., Machine Tool Co. 71	Kennedy, Wm., & Sons 13	Rivett, Lathe & Grinder Co. 119
Armstrong Bros. Tool Co. 96	Deloro Smelting & Refining Co. 6	King, Ltd., Warden 13	Rockwell Co., W. S. 91
Armstrong, Whitworth of Canada. 16	De Mooy Mach. Co. 101	L	Rodlofson Machine & Tool Co. 19
Atkins, Wm., & Co., Ltd. 17	Deminion Machinery Co. 29, 69	L'Air Liquide Society 78	Roper & Co., C. F. 83
Atlas Crucible Steel Co. 16	Dominion Steel Foundry Co. 91	Landis Machine Co. 92	S
Atlas Press Co. 93	Dunry Co., H. A. 7	Lancashire Dynamo & Motor Co. 9	Shuster Co., F. E. 93
B	E	Latiohe Electric Steel Co. 9	Silver Mfg. Co. 93
B. A. B. Model Mfg. Co. 73	Eastern Mach. Screw Corp. 88	M	Simmons Mach. Co., Inc. 50, 105
Babecock & Sons 62	Lames, Chas. F. 82	Mackinnon, Holmes & Co., Ltd. 63	Skinner Chuck Co. 91
Baird Machine Co. 94	Errie Foundry Co. 75	Magnolia Metal Co. 94	Slocum, Avram & Slocum 26
Banfield, E. J. 18	F	Marion & Marion 88	Smalley-General Co. 85
Banfield, W. H., & Sons 63	Fainley, Davidson Steel Co. 14	Manufacturers' Equipment Co. 77	Standard Alloys Co. 10
Barnes, Wallace, Co. 64	Fetherstonhaugh & Co. 62	Marsh & Henthorn, Ltd. 31	Standard Mfg. Co. 84
Baxter & Co., Ltd., J. R. 15	Fitzgerald, W. H., J. 68	Matthews, Jas. H., & Co., Inc. 31	Starrett Co., L. S. 107
Beitram, John, & Sons Co., Ltd. 3	Foss & Hill Machy. Co. 8	McCabe, J. J. 24	Steel Bonding Brake Works, Ltd. 9
Blake & Johnson Co., Ltd. 31	Francis & Co. Inside back cover	McCoy-Brandt Machy. Co. 68	Stetcher Co., Chas. 25
Bliss, E. W., Co. 83	G	McDougall Co., H. Inside back cover	Steel Co., of Canada 3
Blount, J. G. 15	Gardner Machine Co. 103	McLaren, J. C., Belting Co. 92	Steploe, John, Co. 15
Brantford Oven & Rack Co. 65	Garlock-Walker Machy. Co. 25	Mechanical Engineering Co. 81	Stocker-Rumley-Wachs Co. 71
Bridgford Mach. Tool Works 5	Garvin Machine Co. 24	Metalwood Mfg. Co. 82	Saw Mfg. Co. 20
Bristol Company 91	Geometric Tool Co. 61	Metal Drawing Co. 67	Sturtevant Co., B. F. 80
Brown Engineering Corp. 72	Gibb Instrument Co. 86	Milner Smythe Electric Co. 55	Swedish Steel & Importing Co. 11
Brownell Machy. Co. 70	Grant Gear Works, Inc. 92	Miltholland Co., W. K. 25	T
Brown's Copper & Brass Rolling Mills 79	Grant Mfg. & Machine Co. 69	Monarch Brass Mfg. Co. 75	T. C. M. Mfg. Co. 76
Buden, Hanbury A. 62	Greenfield Machine Co. 92	Montreal General Tool Co. 22	Tabor Mfg. Co. 92
C	H	Montreal Machy. & Supplies 101	Taylor Instrument Co. 81
Can. Bond Hanger & Coupling Co. 75	Hamilton Gear & Machine Co. 39	Morse Twist Drill & Mach. Co. 97	Tolsdo Machine & Tool Co. 69
Canada Machinery Corporation Inside back cover	Hanna & Co., M. A. 21	Molern Tool Co. 89	Toomey, Frank A. 91
Canada Sales Co. 86	Hawkrigde Bros. 63	Molern Mfg. Co. 65	Toronto Iron Works 94
Can. B. K. Morton Co. 4	Henley Machine Co. 112	Murphy Machine & Tool Co. 87	Toronto Tool Co. 72
Can. Blower & Forge Co., Ltd. 28	Hess Speed Hammer Co. 99	N	Toronto Welding Co. 69
Can. Fairbanks-Morse Co. 34	Himoff Mach. Co. 92	National Machine Tool Co. 93	U
Can. Desmon-I-Stephan Mfg. Co. 88	Hepburn, John T. 27	New York Machinery Exchange 69	United States Electrical Tool Co. 30
Can. Economic Lubricant Co. 82	Holt Metal Co. 94	Nicholson File Co. 106	V
Can. Ingersoll Rand Co., Ltd. 26	Hull Iron & Steel Pipes, Ltd. 84	Niles-Bement-Pont Inside front cover	Vanadium Alloys Steel 19
Can. Inspecting & Testing Laboratories, Ltd. 91	Hunter Saw & Machine Co. 65	Northern Crane Works 91	Vulcan Crucible Steel Co. 9
Can. Mathews Gravity Carmer Co. 65	Hungerford Brass & Copper Co. 78	Norton, A. O. 92	W
Can. Metal Products 72	Hurlbut-Rogers Machinery Co. 78	Norton Co. 32	Walcott Lathe Co. 11
Can. Monarch Mfg. Co. 71	Hyde Engineering Works 67, 89	Nova Scotia Steel & Coal Co. 12	Wagner & Swasey Co. 23
Can. Steel Foundries, Ltd. 7	I	O	Webber Bros. Mach. Co. 27
Can. SKF Co., Ltd. 33	Ideal Tool & Mfg. Co. 87	Ontario Specialties, Ltd. 94	Wells Bros. Co. of Canada 25
Carlyle Johnson Mach. Co. 8	Independent Pneumatic Tool Co. 37	Oven Equipment & Mfg. Co. 77	Whiting Foundry Equipment Co. 75
Chapman Double Ball Bearing Co. 76	Iron Works, The 63	Oliver Machy. Co. 20	Whitman & Barnes Mfg. Co. 119
Cincinnati Pulley Machy. Co. 19	J	Parmenter & Bulloch Co. 92	Whitney Mfg. Co. 82
Cleveland Pneumatic Tool Co. 28	Jacobs Mfg. Co. 86	Perrin, Wm. R. 85	Williams, A. R., Machinery Co. 61
Cleveland Twist Drill Co. Front cover	Jamline Co., A. B. 101	Pierless Machine Co. 87	Wickes Bros. 20
Clippner Belt Lacer Co. 29	Jencks Mach. Co. 9	Petrie, H. W., Ltd. 67	Williams, J. H., & Co. 105
Colonial Steel Co. 13	Jerbohn, Geo. E. 62	Positive Clutch & Pulley Works 94	Windsor Mach. & Tool Works 19
Cook, Asa S. 93	Jersey City Mach. Co. 66	Reest & Whitney Inside front cover	Winnipeg Gear & Engineering Co. 72
Cuthbert Machy. Co. 68	Johnson Mach. Co., Carlyle 8	Pringle, R. E. T., Ltd. 27	Z
Cummings & Son, Ltd., J. W. 89	Jones & Glasco 29	Puro Sanitary Drink'g Fountain Co. 14	Zenith Coal & Steel Products Co. 92
Cushman Chuck Co. 91		R	Zin-Ho, Mfg. Co. 31
		Racine Tool & Machine Co. 85	

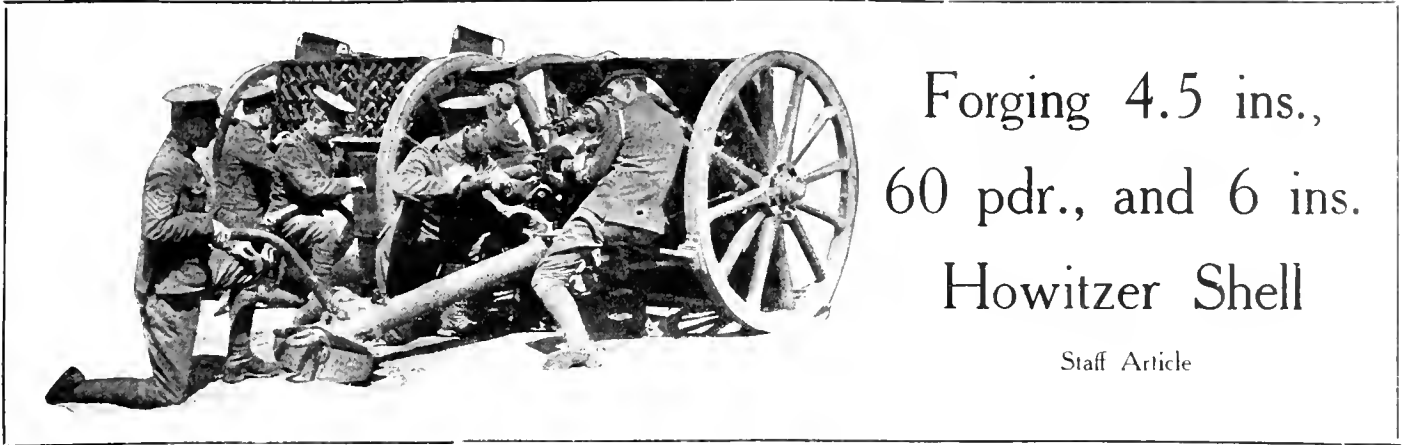

Forging 4.5 ins., 60 pdr., and 6 ins. Howitzer Shell

Staff Article

Shell-making in Canada has become quite commonplace, so to speak, yet whether in the spheres of plant installation and equipment, or those of the operation methods and devices employed, it may be said that a mass of data awaits appropriation, an intimacy with which is no less desirable in the manufacture of metal-working plant specialties generally than in that directly and necessarily to a variety type production of munitions.

ABOUT eighteen months ago when orders for larger shells came to Canada, the output of the then existing forging plants was not sufficient to meet the rapidly increasing demand for their product. Machine shops were multiplying in number, but their operations were somewhat restricted owing to the fact that they could not obtain a sufficient supply of forgings. The need of more forging plants to relieve the situation was therefore very real, but in a comparatively short space of time the situation was adjusted. The plant which is the subject of this article was established a few months after the period referred to above, and has done much to relieve the situation.

It is entirely a forging plant. The billets are shipped in already cut to the required length for forging, after which operation they are distributed to the machine shops to be finished. Forging may be termed an intermediate stage, and is incidentally a very important one. What

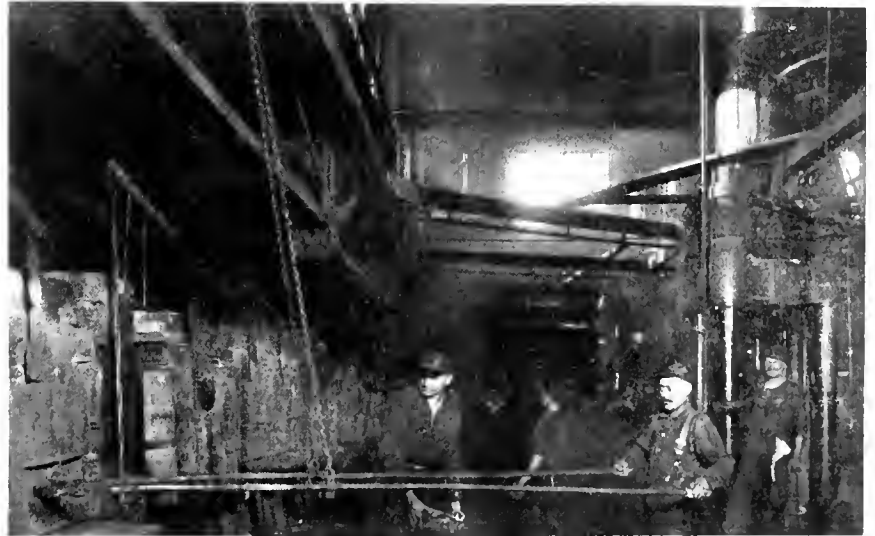

FILLING FURNACE WITH 60 PDR. BILLETS. NOTE OVERHEAD RUNWAYS



ROW OF BATCH FURNACES SHOWING SUSPENDED TONGS USED FOR HANDLING BILLETS.

might appear to the casual observer to be a simple operation, really requires a great deal of care, not only in the construction of the punches and dies, but in the actual forging and heating operations. A forging plant is a costly proposition to install. The presses are powerful machines and require a considerable capacity of pumping equipment to produce the necessary power to operate them.

At this particular plant there are eight Southwark hydraulic presses ranging from 210 tons to 500 tons capacity. The presses are installed in a row lengthways in the shop, with a row of furnaces on either side. This arrangement permits of the billets being lifted direct from the furnace to the press with neither lost time or motion, and obviates any appreciable loss of heat. To facilitate handling of the billets, overhead runways are installed along the front of both rows of furnaces with a turn out leading from each furnace to the press that it is serving. The billets

are carried by means of long tongs suspended about the middle by a chain from a carrier on the runway.

Furnace Installation

The furnaces were installed by the

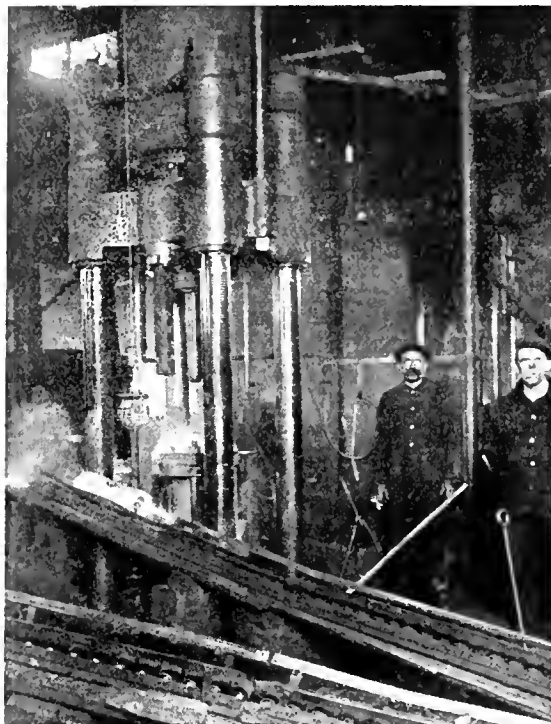

500-TON, 6-INCH SHELL FORGING PRESS WITH GRAVITY CARRIER IN FRONT.

Southwark Foundry & Machine Co. Philadelphia. There are thirty-two batch furnaces and one continuous furnace, the latter being used only for heating the billets for the 6-in. shell forgings. The batch furnaces are used in conjunction with the presses making forgings for the 4.5-in. and 60 pdr. shell. A large number of furnaces are required so that the presses may be kept in operation continuously and not held up waiting for billets. The furnaces are drawn in rotation, that is, while one batch of billets is being drawn from the furnace the other batches are gradually coming up to the required heat. Eight furnaces to each of four presses for the piercing operations are required, making the total of thirty-two batch furnaces.

The continuous furnace is one of the latest type. It is continuous as opposed to the batch type of furnace. The billets are fed into the furnace at the rear, from the billet pile in the yard. The billets roll through the furnace gradually and are drawn from the front as required. The billets are lifted from the furnace to the press by means of tongs in the same way as the smaller billets. The furnaces are all oil-fired, and are maintained at a temperature around 2,200 degrees Fah. The fuel oil is pumped by means of centrifugal pump from an underground tank in the yard to the furnaces. The air pressure for the oil burners is supplied by a Roots rotary blower, having a capacity of 13,000 cub. ft. per minute, and operated by Canadian Westinghouse motor. The blower

and pump are located in a room adjoining the pumping plant.

4.5 in. Shell Forgings

The billet for the 4.5-in. shell is 4.8 ins. diameter, 10 ins. long, and weighs 52 pounds. The forging is of the same diameter and has a length of not less than 13 inches. The billet is heated in the furnace for about one hour. Immediately after being taken from the furnace, the scale is removed and the billet carried by tongs to the press. The removal of the scale is important, otherwise the dies might be damaged, and it might also prevent the steel from drawing uniformly when the punch is being forced into the metal. The billet is then dropped into the die and a centering ring placed on the upper end of die to guide the punch. The punch then descends producing a forging in one operation.

No drawing, properly speaking, is done on this forging, as the piercing causes an upward extension of metal out of the die. The return stroke of the press withdraws the punch and also forces the forging up from the die; the punch is then cooled by means of running water, and all scale is removed from the die box. Two presses are working on 4.5-inch shell forgings at this plant. All punches and dies are made of vanadium steel.

60 Pdr. Forgings

The forging of billets for 60 pdr. shell

involves two operations, piercing and drawing. There are two sets of presses, making four altogether; two for the piercing operation being 350 ton presses and two for drawing being 210 ton units. The billet for the 60-pdr. forging is 5.45 ins. in diameter by 13 13/16 ins. long, and weighs 86 pounds. The forging is also 5.45 ins. in diameter, but the minimum length is 18 inches. The first or piercing operation is practically identical with that described above for the 4.5-in. forging. The billet after being pierced is put in the furnace for a short time to bring it up to forging heat again. It is then scaled and lifted over to the drawing press.

In the drawing operation, the punch is brought down so that its point exerts a certain pressure on the bottom or pocket of the forging which is supported on a die plate held over the opening of the main die. After the pocket is formed, the punch is drawn up a short distance to allow the die plate to be withdrawn, when the punch is forced downwards through the main die, the tapering bore of which reduces the outside of forging to the required size. The forging falls through to the ground and is then removed away to be cooled. The forgings are piled up in batches and cooled slowly to minimize the possibility of hardening.

6-in. Shell Forgings

The billets for 6-in. shells are forged in two 500-ton presses. Only one operation is necessary, that of piercing, so both presses are engaged in the same work. The billet is 6.4 in. in diameter by 17 ins. long, and weighs 158 pounds. The forging is of the same diameter, but has a minimum length of 23 inches. The piercing is done on the 6-in. forging in the same manner as far the other shells described above. The continuous furnace already referred to is used in conjunction with these two presses. The



TWO 500-TON PRESSES FORGING 6 INS. SHELL, CONTINUOUS FURNACE IN REAR, AND GRAVITY CARRIERS ALONGSIDE EACH PRESS.

6-in. forgings are considerably heavier than the 60-pdr., and so to facilitate handling, a system of gravity carriers has been installed.

In the illustration will be seen the

material to ease up internal strains when allowed to remain quiescent for a more or less extended period of time. It seems as if the molecules in such a casting, by virtue of their mobility, can

is simply the difference in dimensions of the casting red-hot and cold. In fact, it is really a volumnar contraction, and takes place after the metal has set.

The real shrinkage covers an entirely different situation. When a casting is poorly designed, it is impossible to feed the mold properly when pouring. The thinner sections set more quickly than the thick ones and may leave the latter without means of drawing in liquid metal to compensate for the reduction in volume in the act of setting. As the metal sets against the mold walls first, and gradually thickens from the surface inward, when the influx of fresh supplies is stopped there results a void in the centre, or at least a spongy portion. This is shrinkage, and can be seen more particularly in white iron, by reason of its greater reduction in volume from liquid to solid form, apart from the final contraction from red heat to ordinary temperatures. Such shrinkage usually takes place at abrupt angles, in thick parts adjoining thin ones, in the rims of flywheels, hubs of pulleys, at the flanges of cylinders, etc.

Dual Volume Reduction

It will be seen from the above that there are really two kinds of reduction in volume to be reckoned with: First, that due to the change from the liquid to the solid state; second, the reduction in volume after setting until ordinary temperatures have been reached. The first, often called interior shrinkage, is a rather serious occurrence. The specific gravity of molten iron is about 6.65; it does not vary widely from this figure whether the metal on setting is grey or white in fracture—all the carbon being combined when in the molten state. On setting, however, if grey iron results, the specific gravity will be over 6.8, and if white iron, up to 7.8. The formation of graphite in the structure accounts for the comparatively moderate increase in the case of grey iron. In average cast iron with 7.3 specific gravity, the increase in density is 0.65, or 9 per cent., which means a very big decrease in volume for equal weights of molten and solid metal. This situation accounts for the quantities of molten metal that have to be added to a mold after pouring it full in the first place, and in the case of small castings, particularly when of white iron, for the funnel-shaped sprue left in the pouring basin or gate.

Contrast this with the eventual reduction in volume after setting. Here we have a linear reduction of about 1 per cent. in every direction, which is an infinitesimal amount when compared with the real metal shrinkage.

It stands to reason, that, if the metal in setting has the power to pull apart, whatever liquid material may remain after feeding has stopped, thus causing large spongy parts in the interior of a casting; powerful strains which affect the strength injuriously must have occurred. This is apart from the reduction of strength in the material for the section itself. In other words, not only will the metal have a lower tensile strength because of the spongy nature



FURNACES USED FOR ANNEALING FORGINGS THAT REQUIRE HEAT TREATMENT.

carrier by which the hot forgings after being pierced roll down from the press to the ground. Another system of gravity carriers picks up the forgings near the press and carries them to the other end of the shop to the cooling piles. The carrier systems were supplied by the Canadian Matthews Gravity Carrier Co., Toronto. They save both time and labor, and assist in the generally efficient operation of the plant. All the forgings of each size have the billet number stamped on the base.

Hydraulic Plant for Presses

The hydraulic plant for operating the presses consists of two large accumulators and five motor-driven pumps. The pumps are horizontal, direct-acting units, and were built by the Deane Steam Pump Co., Holyoake, Mass. Three of these pumps have a capacity of 250 gallons per minute, each being driven by a 250-h.p. Canadian Westinghouse motor. Another pump has a capacity of 200 gallons per minute, and is driven by a 200-h.p. Canadian Westinghouse motor, while the fifth pump is a 150 gallons per minute unit, and is driven by a 150-h.p. Canadian Westinghouse motor. The motors are all A.C. machines using Hydro current.



SEASONING OF CASTINGS*

By Richard Moldenke.**

ONE of the little-known characteristics of cast iron, which nevertheless has an important bearing on results where accuracy in machining is essential, is the ability of this

adjust their relative positions to an extent sufficient to overcome some of the existing stresses.

The following instance will perhaps give a fair idea of the condition a casting may be in when just shaken out of the sand: A very large sheave-wheel, after shaking out, was taken outdoors to be cleaned and made ready for turning up. It was leaned against the side of the building, but before much could be done an arm tore apart with a loud report. Investigation showed that the sun had been shining on the upper rim, thus adding a slight strain to those already existing within the arm and thus overbalancing the strength of the metal in tension. Had this sheave been kept under cover for a while, or at least until machined, the strains would have eased off sufficiently and allowed the sun to look upon it without disaster.

It will not be necessary to multiply examples. Every engineer knows the danger of water-hammer in pipe lines, particularly if the latter are of cast iron. Every mechanic knows, or should know, that it is not good to strike a fitting that is under steam pressure.

Shrinkage and Contraction—A Distinction

It will be necessary to write a few words about the internal strains in castings—the so-called casting strains we hear so much about. It is generally known that to get a casting reasonably true to the dimensions wanted requires a slightly larger pattern. The usual allowance for grey iron is $\frac{1}{8}$ inch to the foot, and $\frac{1}{4}$ inch to the foot for white iron. This reduction in length, breadth and thickness in a casting is erroneously called shrinkage. It should be called contraction, as for practical purposes it

*From a paper presented at the American Institute of Mining Engineers, New York, Feb., 1917.

**Consulting Metallurgist, Watchung, N.J.

of part of the section, but the interior strains counterbalance part of the tensile strength that is available.

This situation is intensified by the fact that the metal in setting does so far more quickly at the mold surface than in the interior—the cold sand walls drawing away the heat from the molten iron more quickly at the beginning of the setting process than later when this heat has to travel through a more or less thick shell of metal already set. The consequence is a higher percentage of combined carbon at the surface than in the interior of the casting. In chilling the surface, we have a white iron surface and a grey iron interior. The relative change in the specific gravities of the same molten iron turned into two extreme forms of iron as cast will indicate what strains there must be within the casting due to the differences in volume which the two metals want to occupy when set, but cannot properly occupy on account of the quickness of the setting action.

Contraction of Set Metal

Finally come the strains due to the contraction in the set material until ordinary temperatures have been reached. This has been stated as $\frac{1}{8}$ inch to the foot in grey iron and $\frac{1}{4}$ inch to the foot in white iron. In large castings this is very serious. Suppose, in the case of a big flywheel, the rim sets fast enough to hold the much cooler arm as in one set of jaws of a testing machine, the hub, held by the arms on the other side of the wheel, being the other set of jaws. Surely the arm in wanting to reduce in length $\frac{1}{4}$ inch to the foot must be under a terrific strain if not allowed to do so. In the case of white iron the situation is much worse. Such castings as hand-brake wheels (subsequently annealed for malleable castings), snap apart when allowed to cool in the sand in the ordinary way. Work of this kind must be shaken out as quickly as set, taken to special ovens and allowed to cool down very gradually.

Overcoming Injurious Strains

Sufficient has been said to make the case of cast iron look very weak. Fortunately, there are two phenomena which help to overcome some of the injurious strains set up. The first is the fact that cast iron in the act of setting (between liquid and solid), can be stretched. The second is the seasoning or easing up of the remaining strains after the final contraction through the mobility of the molecules. It is the stretching of grey iron during the setting that saves the flywheel arm from rupture before the new strains due to final contraction are introduced. It is the inability of white iron to stretch very much, which causes so many cracked castings in the malleable process which would not be seriously affected by the final contraction.

Castings Test

This discussion of the actual situation in making castings has another bearing. Purchasers of castings may wonder why

foundry men who really know something about their basic material are so uncompromisingly opposed to test coupons on their product. The man who is at least somewhat familiar with cast iron should realize that it is unfair to the maker of the casting to judge its value by a test piece subject to a variety of strains introduced as the result of position, manner of attachment, method of pouring of the metal, etc. It is further unfair to the purchaser to judge by coupons, as there are many ways of artificially strengthening such test pieces. There is only one way of testing a casting properly, and that is to break it. Obviously this will not do, and hence for repetition work a given percentage of castings can be thus tested. For all other cases the only method of obtaining reasonable assurance on the subject is to make standard test bars, entirely apart from the castings, but of the same iron. These test bars should be made under conditions giving the iron the best possible chance to show just what it is, neither artificially strengthened, nor filled with strains and thus deliberately weakened.

Every mechanic knows that, in planning up a slab of cast iron on both sides to get a true job, it is necessary to take a light cut, reverse, and take a cut on the other side, then reverse again for the finishing cut, finally reversing for the last cut. If this is not done, there will be warped surfaces to deal with on account of the internal strains. Again, it is well known that a true piston is rather difficult to produce. Even after grinding to a finish, it is apt to get out of true. It is not so generally known, however, that if such a cast iron plate or piston is allowed to remain in storage for a long period, the results will be much more satisfactory. The castings have seasoned. Where establishments are familiar with future production demands, orders for castings are placed far ahead of requirements. Since, however, on getting to the bottom of a big pile the difficulty of tracing defective work becomes correspondingly harder, only shops having their own foundries are likely to do much storing.

The present demand for very high-class machined castings, as evinced by automobile cylinders, pistons, engine and compressor cylinders, etc., should bring this question of seasoning out very prominently. Inquiry by the writer has shown but little knowledge on the subject in the trade generally, though first-class foundrymen were very much alive to the matter. In general, the difficulty seems to be the inability of storing up ahead, or, if this is done or discovering defective product when least expected.

Increasing Strength by Tumbling

We are indebted to the well-known metallurgist, A. E. Outerbridge, Jr., for what seems to be the best indirect explanation of seasoning. In his famous experiments on tumbling castings to increase their strength, he found that by the action of light blows, often repeated, the internal strains were relieved to such an extent that the real value of

the metal came into play. The mobility of the molecules was aided by artificial means. Incidentally, however, the tests establish the mobility of the molecules in cast iron very satisfactorily. Replace half-an-hour's tumbling by six months' quiescence and the molecules will have done their work with somewhat the same results.

In view of the possible depression scheduled for us on the close of hostilities in Europe, would it not be well to ease up operations slowly instead of shutting down tight? This would help the industrial situation adjust itself more safely and at the same time permit supplies of castings to accumulate, which will be all the better for having seasoned.



BRITISH MUNITION PLANTS AFTER THE WAR

IN discussing the possible uses after the war for the additional plants and machinery that have been created for the production of munitions in Great Britain, the *London Times* calls attention to their enormous importance as a national asset and to the thought which their destiny has stimulated in the engineering trades. It further states:

"Perhaps the most pregnant of the many suggestions are those which contemplate these factories as the new homes of old and smaller works. Among the respects in which British manufacturers have been at a disadvantage compared with their competitors in the United States is the nature of their premises. The old establishment that has given them experience and connection has also given them old premises, round which have grown up houses which now are themselves old, and are often placed in neighborhoods which are as little suited to the best development of the workers and their families as the old works and some of the old prejudices are to the efficiency of the business. To move these works from the slums in which many of them are placed into neighborhoods with light and air and grass, and to transfer their machinery from shops that have grown up without plan into premises designed for efficient handling and 'routing' would be to give the workers and the enterprise a fresh lease of life.

"Some point out that the design of these new works is particularly adapted to subdivision and suggest that their utility would be all the wider and more general if they were divided into separate occupations and used by firms of whom each could specialize in the quantity production of individual parts, and one or more in the assembling of them. This method has been used largely and successfully by American manufacturers, sometimes further apart from each other than these works would be. The advance which has been made for war manufacturers in the use of limit gages and the production of interchangeable parts has placed British engineering in an entirely new position for adopting this method of manufacture generally."

PRODUCTION METHODS AND DEVICES

A Department for the Interchange and Distribution of Shop and Office Data and Ideas Evolved from Actual Practical Application and Experience

MILLING SLOTS IN SHELL NOSES By R. Hamilton.

AMONG the changes effected in the 4.5 Mark VII., high explosive shell, is that of three small slots to be cut in the nose, at an angle of 30 degrees with the face. The purpose of these slots is to lock the fuse in a permanent position, after it has been firmly screwed in, by burring the metal of the fuse down into these three slots. While the operation of cutting these three slots is comparatively simple, the time required to perform the work and the method of holding the shell while doing so is an important factor in the rapid accomplishment of such an apparently little detail. Various methods have been adopted for holding the work, some of these being more or less complicated, but the two sketches herewith illustrate devices both simple in design and efficient in operation. They were developed by the Imperial Munitions Board from suggestions submitted by Williams & Wilson, Montreal. Both fixtures are made for milling machine use; Fig. 1 to be moved horizontally below the cutter, and Fig. 2 to be operated vertically at one side of the cutter. The body casting is made so that the bore will come at an angle of 30 degrees with the vertical, a recess being provided to assure a clean cut being taken for the fit of the shell chuck B, this piece having a collar cast integral with the main portion, so that the shell can be revolved freely. A small hole D is drilled in the base to allow the free escape of air when the shells are being placed in position. Three equidistant holes are drilled near the base, so that the chuck can be locked in the desired position when slots are being

milled. The locking bolt E is operated by the spring shown, and released by the knurled button F.

The design of the fixture shown in Fig. 2 is somewhat different, but in this case the table of the machine is operated in a vertical direction to mill the slots. The body casting in this instance is made so that the axis of the shell is kept at an angle of 30 degrees with the horizontal. To the base of the fixture A, two small steel pieces are secured to retain the jig in a central position with the milling machine table. The shell retaining piece C, which revolves in the main casting, has a quick-acting clamp-

fully performed in order that the surface of the inside walls will be in a condition to receive and retain the coating of varnish with which all shells are prepared. The method of applying the cleaning medium is one that should receive a great deal of attention, and a careful study of the various requirements is a very important factor in the securing of satisfactory results. The general practice has been to force the sand or grit into the shell without considering the work that is to be accomplished. When the sand is blown directly into the shell in a vertical direction, the base receives the full force of

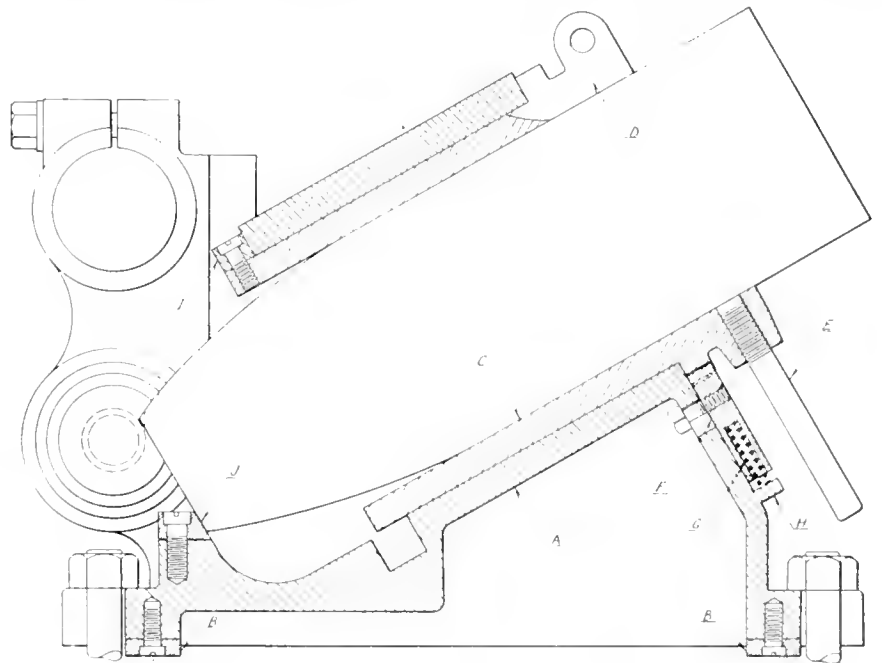

FIG. 2. MILLING SLOTS IN SHELL NOSES.

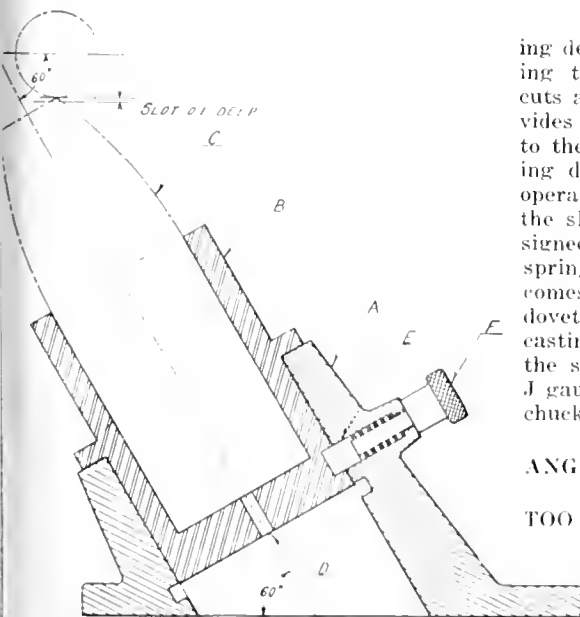

FIG. 1. MILLING SLOTS IN SHELL NOSES.

ing device, as shown at D, thus preventing the shell from turning while the cuts are being made. The handle E provides an easy means of turning the shell to the three desired positions; these being determined by the locating bolt F, operated by the spring G acting against the shoulder H. This portion is so designed that it is self-releasing, the bolt springing into position when the slot comes in line; the bolt operating in a dovetail slot cast integral with the main casting. Lateral play is eliminated by the short sectional collar I. The block J gauges the location of the shell in the chuck.

ANGULAR SHELL GRIT CLEANER By J. H. R.

TOO much emphasis cannot be laid on the necessity of thoroughly cleaning the interior of the shells after the nosing operation and subsequent machining. It is essential that this operation be care-

fully performed in order that the surface of the inside walls will be in a condition to receive and retain the coating of varnish with which all shells are prepared. The method of applying the cleaning medium is one that should receive a great deal of attention, and a careful study of the various requirements is a very important factor in the securing of satisfactory results. The general practice has been to force the sand or grit into the shell without considering the work that is to be accomplished. When the sand is blown directly into the shell in a vertical direction, the base receives the full force of

the blast, and the cleaning of the walls and the profile just inside the nose can only be accomplished by the action of the sand as it falls back and out of the shell. Owing to the condition of that portion of the shell immediately below the nose thread, caused by the hot nosing process, a scaly surface is unavoidably formed, and where machining is not resorted to, it is highly desirable to thoroughly clean this section before the varnish is applied. Even when this profile is machined, it is well to have the sand come in contact with the surface so that all grit or scale will be removed. After much experimenting with various forms of sand-blasting appliances, the Jenckes Machine Co., Sherbrooke, Que., designed the cleaner illustrated in the accompanying sketch.

The construction of this device is such that the sand is blown directly against that section of the shell that most requires it. Owing to the velocity at which the sand is forced into the shell, it is

practically impossible to have any bends in the nozzle pipe, as the friction would be so great that the life of the nozzle would be very short. For this reason it

shell. The action of this device is highly satisfactory, the angular direction of the blast proving a very efficient method of cleaning the inside profile of the nose.

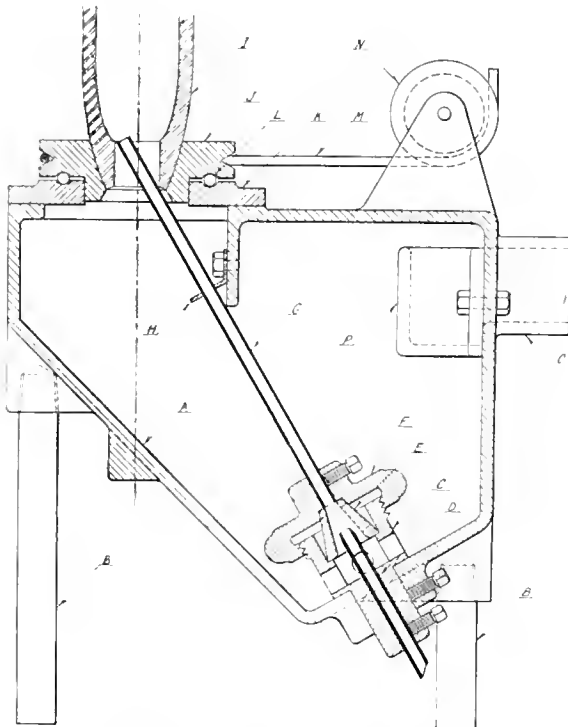

ANGULAR, SHELL GRIT CLEANER.

is deemed very advisable to have the sand forced through in a direct line. As it is also obvious that the entire circumference be subjected to the action of the blast, the shell is placed in a vertical position and revolved during the cleaning operation. As shown in the sketch, the bowl or container A is mounted in such a position that the upper surface lies in a horizontal plane, legs B being of suitable length to attain this ideal. Secured to the lower section of the container is the connecting piece C, through which the air pipe D passes; being firmly secured by the set screws shown. The cone-shaped injector piece E is held in position by the nut F. The delivery pipe G which carries the air and sand to the work is firmly held in the nut F, the lower end resting on the cone E, while the upper end is supported by means of the band iron clamp H. The shell I is held in a vertical position, the nose resting in the piece J, riding on ball bearings on the roller plate K. The rotating flange, together with the shell, is operated by the small 3/8-inch round belt M, passing over the idler N, and up to an overhead shaft. While the sectional view of this device only shows one shell being operated on, the cleaner now in use is of the twin type, so that two shells can be operated on at the same time. The sand enters the bowl or container through the opening O, being deflected by means of the box P. When the air is turned on, the force of the blast draws the sand in through the openings in the piece C, and forces it along with the air through the cone E, and then up the delivery pipe G to the interior of the

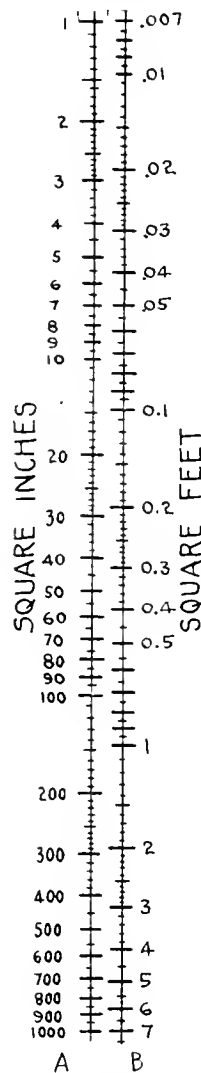

CONVERTING SQ. INCHES INTO SQ. FEET

By N. G. Near

ENGINEERS will find this scale handy for quickly converting square inches into square feet, or vice versa. Simply glance across from one column to the other and the answer is immediately found. For example:—How many square feet are there in 300 sq. inches?

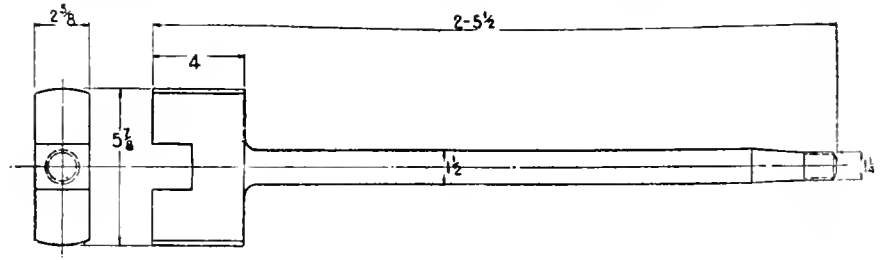

FIG. 1.

Find the 300 in column A and glance across to column B. The answer is—practically 2.1 sq. ft. Again, how many square inches are there in 2 sq. ft.? Find the 2 in column B and glance

across to column A. The answer is, of course, 288, but we would call it roughly 290.

The first operation is the one that is most difficult to perform "longhand." Multiplying generally comes more easily, and so the second operation would perhaps be used more often.



MACHINING PISTON ROD FORGINGS ON HEXAGON TURRET LATHE

Herbert's Monthly.

THE hexagon turret lathe is principally intended to be used for making articles direct from the bar, the great savings in labor costs which can be effected by its use resulting from the speed with which the work can be turned out and the elimination of the expensive process of forging. The possibilities of the machine on bar work are now generally recognized, but it is not always realized that it may also be used to great advantage for dealing with many articles which, owing to their shape, must be made from forgings.

In Fig. 1 is shown a combined piston rod and crosshead for a steam winch. This article must obviously be made from a forging, and might, if made in large quantities, be looked upon as a job for a combination turret lathe; if only a small number could be put in hand at one time, it would probably be finished in an ordinary centre lathe. The hexagon turret lathe is, however, the proper machine to use for this work; it is better than the combination turret lathe, because only one or two special tools, in addition to the standard equipment, are required, whilst the time taken to complete the piece (30 minutes) is about one-fourth of that which would be necessary if the work were done on the ordinary lathe. Particulars of the tool layout are from the plant of John Lynn & Co., Sunderland, England, who are regularly finishing these piston rods on a hexagon turret lathe, and it will be noted that they demonstrate in a convincing manner the flexibility of the machine; similar adaptations will doubtless occur to other users.

At preliminary operations the two sides of the crossheads, the slot and the end, are machined symmetrical with the rough piston rod, so that when chucked in the fixture it will run true. The method of chucking and the tool layout are

shown in Fig. 2, the tools being numbered in the order in which they are used so as to illustrate the sequence of operations. The work is held on a special fixture bolted to the spindle flange.

the design being such that the draw-in chuck does not need to be removed. The fixture itself is of mild steel, turned circular, and then milled away to form an angle plate. The work is located from the previously machined slot by a square-headed stud driven into the centre of the fixture, and is clamped by a nut, stud and clamp plate.

1—This is a standard 3/8-in. taper shank twist drill, which drills a little way up the end of the work so as to provide a support for the starting tool (2). The drill is held in a taper socket in the turret hole, the end being supported by a cast iron bush fitting in the triple tool-holder.

2—This is a starting tool which trues up the end of the forging so as to give the roller steady turner a true start. It is provided with a revolving steady peg fitting in the 3/8 in. hole.

3—This is a standard roller steady turner, which turns the 1 1/2 in. diameter at one cut.

4—This is another roller steady turner, which turns the thread diameter. In this case the rollers are running on the

7—This illustrates a standard roller steady ending tool, which rounds the end of the work.

8—This shows Coventry self-opening die-head for screwing.

— ❁ —
COPPER IN STEEL

By Dale Street

FOR more than two generations the presence of copper in steel has been considered in many quarters to have a wholly deleterious effect, and one may still come across steel specifications in which copper is barred. Yet it has been long ago proved that copper in steel, instead of being an evil, is quite harmless, and is sometimes distinctly beneficial. The evidence is overwhelming that small quantities of copper, say, about 0.5 per cent., have little or no material influence on mechanical properties. It is still held by some that copper tends to make steel red-short, but many authorities who have made reliable trials have found it to have no such effect. Arnold, Stead and Evans found that the presence of 0.1 per cent. of copper in steel had only the most trifling effect in its qualities, and that

taining a fine structure, (b) hardening, (c) securing the best mechanical properties, and (d) hardening with a view of subsequent tempering, is one of great interest in connection with the influence of elements on the mechanical properties of steel. Sauveur gave 800 deg. C. as the temperature suitable for hardening, tempering, and annealing steels containing between 0.9 and 1.5 per cent. of carbon; but Dr. Stead remarks that in hardening razors and fine-cutting tools it is not usual to heat the steel above 760 deg. C. As a matter of fact, 735 deg. to 740 deg. is the theoretical point to which they should be heated, but in practice it is found safer to exceed this, as it is impossible for the artisan to obtain the exact temperature, and he might sometimes have the heat below the critical point, and so produce soft instead of hardened steel, on quenching in water. Dr. Stead confirms Professor Arnold's contention that there is a range of only 2 or 3 deg. between the temperature at which the steel, on the one hand, becomes intensely hard on quenching, and that at which, on the other, it is quite soft.

Whilst there is little harm in going somewhat above the theoretically correct temperature, that process must not be carried too far. Carbon tool steels, if heated to 900 deg. or 1,000 deg., and quenched from these temperatures, would be useless for cutting purposes, and would have a glaring coarse fracture when broken, and be exceedingly fragile. Subsequent tempering, however, modifies the condition. Brinell and others have found that steels with from 0.6 to 1 per cent. carbon give good mechanical results, if hardened at a temperature of 1,000 deg., and afterwards tempered at 550 deg. C., compared with steels normalized at much higher temperatures, and which have a coarser structure. It would appear, therefore, that temperatures suitable for hardening and refining are lower than those which should be used for normalizing and for hardening and tempering. Dr. Stead puts these conclusions into graphic form by super-imposing upon Sauveur's original curve of oil hardening and tempering temperatures two further curves, one indicating the temperatures to which theoretically pure carbon steels should be heated to obtain the finest structure and for hardening tools, and the other the temperatures which should be used when heating for oil hardening and tempering to get the best mechanical properties.



— ❁ —
TEMPERATURES FOR CARBON STEELS

By Mark Meredith.

THE question of the temperatures to which pure carbon steels should be heated for the several purposes of (a) ob-

Censor Humor.—A soldier writing home to his people described how he had been buried alive for a couple of hours in a demolished dugout, but was eventually extricated by his comrades. He added by way of consolation "I had the satisfaction of sending five of the Germans to hell." The Censor in passing the letter had drawn a line through the sentence, but wrote underneath—"It is not permitted to refer to the whereabouts of the enemy."

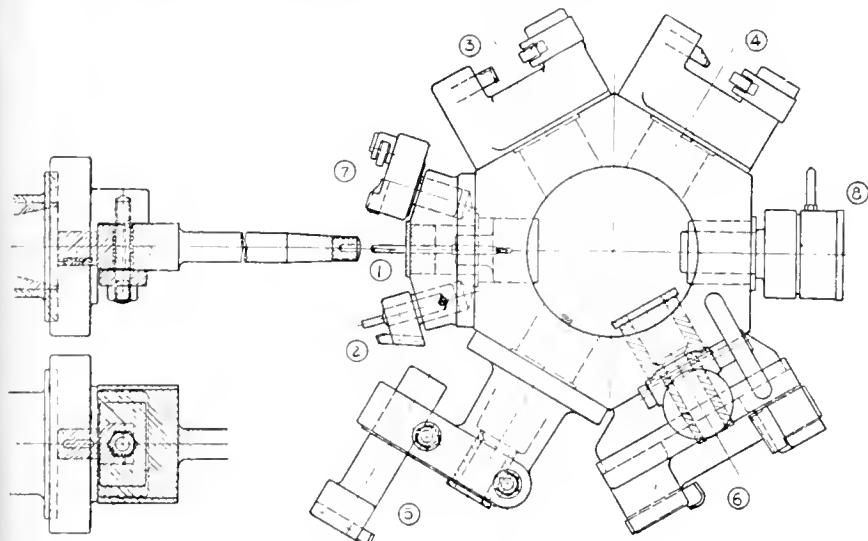

FIG. 2.

1 1/2 in diameter, and the tool is cranked so that the cutting edge is behind the rollers. In this way concentricity between the two diameters is assured.

5—This is a knee-turning tool-holder for turning the large diameter. It is provided with a supporting bush fitting on the 1 1/2 in. diameter.

6—This is a special forming slide operated through a worm and worm wheel, which carries two tools. The first tool is used for facing the shoulder, and is carried on the back of the slide. The standard cut-off slide, being lever-operated, is unsuitable for this facing operation, as the cut is an intermittent one. Two bushes are provided in the turret hole for use with this slide, and are interchanged, this being done without difficulty in the relieved turret holes. The first bush fits the 1 1/2 in. diameter whilst facing is taking place; the second one fits the thread diameter, and is used whilst forming the taper with the tool on the front of the slide.

such effect as it has is in its favor. It raises the yield point and tensile strength, and has little effect on the ductility. Some of the finest tool steel ever made contained 0.2 per cent. copper. It has been proved by Dr. Stead and others that even small quantities of copper in steel make it more resistant to acid corrosion, and D. M. Buck has shown that copper in steel preserves them from general corrosion. Dr. Stead attacks the prevalent prejudice against copper with characteristic vigor, and protests that it is time it was abandoned, if only for the reason that it has prevented the importation into Britain of cupreous iron ores, which are really excellent for steel-making.

PROCESSES IN MANUFACTURE

Inventive Genius and Research Operate to a Dual End—They Aim to Improve What We Now Possess and Bring to Our Service Commodities Before Unknown

HEAT TREATMENT OF LARGE FORGINGS

By Sir William Beardmore, Bart.

IN the heat treatment of large forgings, there are no metallurgical principles involved which do not apply with equal force to the heat treatment of small forgings, such differences as exist being entirely due to the limitations which large forgings impose on the practical conditions under which the heat treatment is carried out. For every class of forging, it is desired that the material from which it is made should give the mechanical tests required by a suitable choice of composition, but, in addition, it is most necessary that the material be in such a physical condition that brittleness and chance of sudden failure be reduced to a minimum.

In carbon-steel forgings produced to meet a definite mechanical test specification, this is equivalent to saying that the steel must possess the least crystalline growth or the smallest grain size, and the object of all heat treatment is to confer this condition on the forging before it leaves the steel works. It is well known that, at any chosen temperature, the time the material is kept at its heat and the time taken to cool down to normal temperature again have an all-important influence on the grain size, and it is for this reason that in large forgings all the difficulties of heat treatment are magnified; and, in the author's opinion, a limit is ultimately reached in the size of the forging beyond which a plain carbon-steel cannot be used with safety, and the use of an alloy steel becomes imperative.

The slowness with which heavy masses of steel cool down results in large crystal grains at the centre of the mass, and, to avoid this, recourse has to be made to oil-quenching to hasten the cooling down, and so to diminish the size of the grain, while a subsequent reheating is generally necessary to remove the hardness introduced by the quenching operation. With small forgings, a simple annealing will put the material into the condition which will give satisfactory and safe results, but for large forgings some form of heat treatment is very necessary to get the best results.

It is a fact which is not sufficiently realized by engineers that, in plain carbon-steel, the effect of oil-quenching is not uniform over the cross-section, but diminishes the farther one goes from the outside surface. With very large forgings, therefore, a stage is reached at which, owing to the size of the forging, the quenching effect at the centre is so small that it is insufficient to confer any benefit on the material, and it be-

comes impossible to guarantee the uniform results which are wanted. That this effect is a real one can be seen from the accompanying photomicrographs of a large oil-treated shaft and from the tests taken. This shaft is 18 inches diameter, and of the following per centage composition:—

C.	Mn.	Si.	S.	P.
0.18	0.65	0.10	0.048	0.037

It was heated in 820° C. (1,505 F.), kept two hours and cooled in oil. Tests were taken from the outside skin and centre, and gave results as shown in the following table:—

	Elastic Limit Tons per sq. in.	Ultimate Stress. Tons per sq. in.	Elongation on 2 inches. Per cent.	Reduction of Area. Per cent.
Outside	17.5	33.1	27.0	53.1
Centre	15.0	29.0	31.0	46.0

The structures are given in photomicrographs, Figs. 1 and 2, being the outside and inside respectively. The tests taken from the centre of the shaft have a lower tonnage than those from the outside, due to the fact that the quenching is not so effective. Photomicrograph Fig. 2, confirms this. With a higher carbon steel it can be understood that the difference will be greater.

ing should have a minimum value which it is advisable should not be less than three. Preferably it should be as great as possible, but it cannot always be adhered to, since for large sizes it is limited by the maximum size of ingot with which the presses can deal and sometimes by the shape of the forging itself.

For an ingot 83 inches in diameter the maximum size of the forging should not exceed 48 inches for the best practice, and from a steel-maker's point of view, until the demand warrants the outlay of

plant for dealing with still larger ingots, larger forgings than this should be built up rather than manufactured in one piece. In this connection the cause of commercial efficiency would be better served if engineers, in bringing out new designs in heavy steel construction, would consult the metallurgist and the steel manufacturer as to the best method

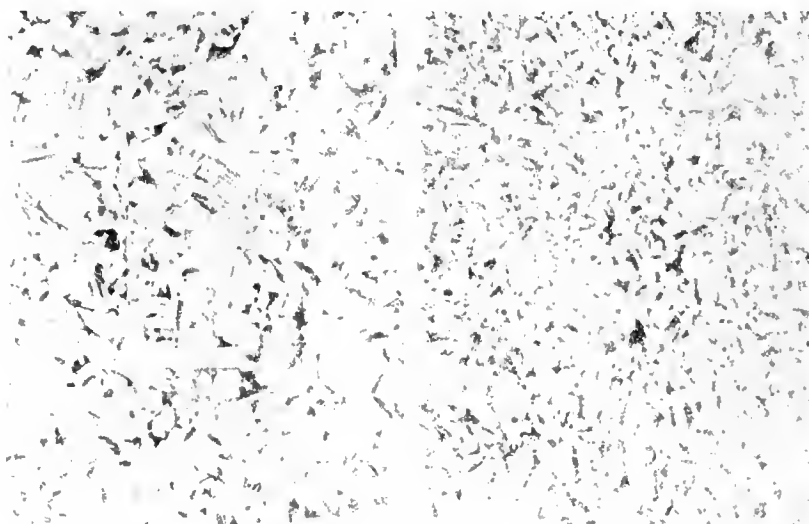

OIL HARDENED 18-INCH SHAFT MAGNIFIED 100 DIAMETERS.
FIG. 1. OUTSIDE SKIN. FIG. 2. INSIDE.

The effect of work is very important, and there is an intimate relation under practical conditions between the grain condition of a forging and the amount of work which has been put on it during forging. For the very best results, the ration of the cross-section of the ingot and the largest cross-section of the forg-

ing should be such that the grain structure of the design and production of special requirements.

Though not strictly a forging, the following example illustrates very well what has been said above regarding the heat treatment of heavy forgings. The order specified steel discs 55 inches dia-

*From a paper presented before the Institution of Mechanical Engineers.

meter and 11 inches thick with a mechanical test of—

This was the best that could be obtained, and was below the specified tests.

In this way it was sought to avoid any unsoundness that might exist down the centre line. At the same time the test specification was amended so that the elongation required was 22 per cent. on 2 inches instead of 20 on a ratio

Yield-Point. Tons per sq. in.	Ultimate Stress. Tons per sq. in.	Elongation (on ratio Per cent.	length diameter = 10)
23	45	20	

They were required to revolve at a high speed, and for magnetic reasons it was necessary to use a carbon-steel. The ingots were forged and then rolled to size from material of the following composition:—

There were two reasons for this; the carbon was too low and the thickness of the slabs was too great to allow the oil-quenching taking sufficient effect to attain the high tonnage required. An-

length
— = 10. The plate was heat-diameter

treated as follows:—

C.	Si.	Mn.	S.	P.
0.53/0.54	0.18	0.50	0.029	0.040

(1)—Heated to 900° C. (1,652° F.), kept 1 hour and cooled in oil.

(2)—Heated to 760° C. (1,400° F.), kept 1 hour and cooled in oil.

(3)—Heated to 640° C. (1,184° F.), kept 8 hours and cooled in air,

and were given a heat treatment after this operation, which consisted of—

higher carbon material giving—

(1)—Heating to 780° C. (1,436° F.) for 2 hours and cooling in oil.

(2)—Heating to 550° C. (1,022° F.) for 4 hours and cooling in air.

Tests were taken from the centre of the slab (midway between the two surfaces), and they gave the following results:—

C.	Si.	Mn.	S.	P.
0.62 0.63	0.25	0.70	0.023	0.021

other ingot was therefore cast, from a and it was forged and rolled to 5½ inches thick to the size given in Fig. 3

—	Yield-Point. Tons per sq. inch.	Ultimate Stress. Tons per sq. inch.	Elongation (on ratio Per cent.	Reduction of Area. Per cent.
Cross test	23.6	42.3	14.0	39.3

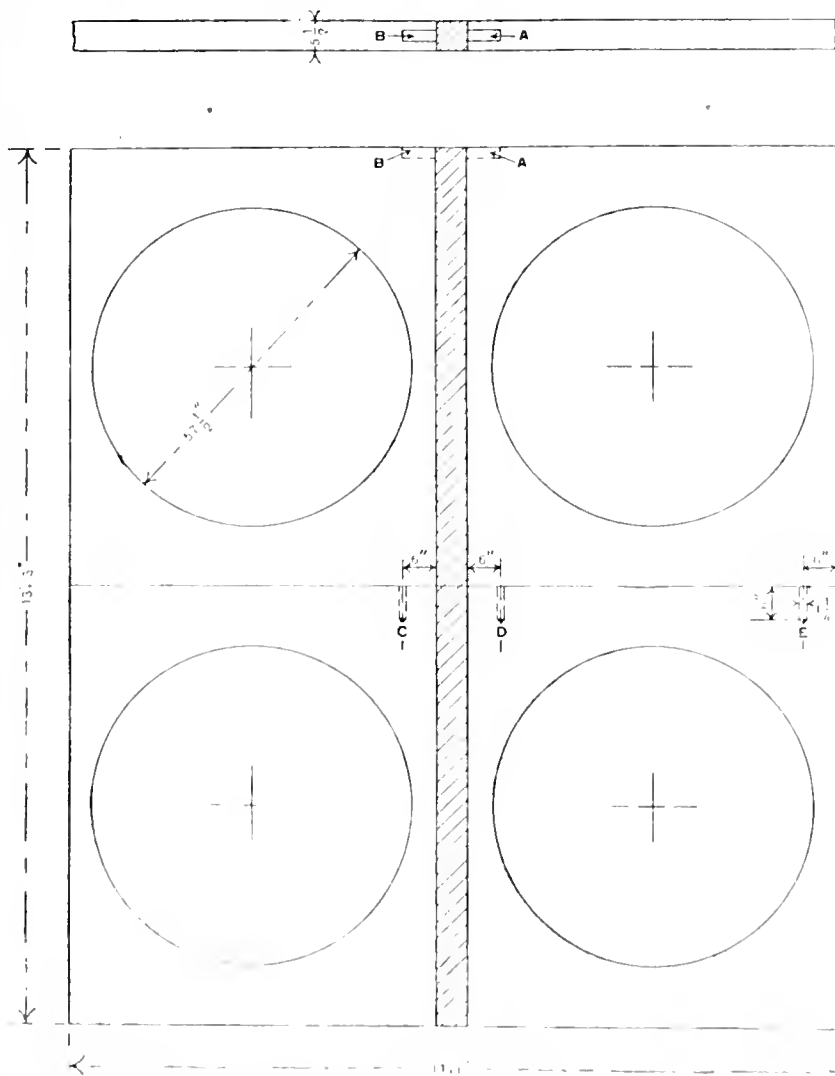
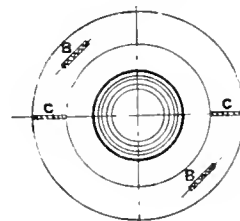

FIG. 3. FORGED AND ROLLED SLAB USED FOR TEST

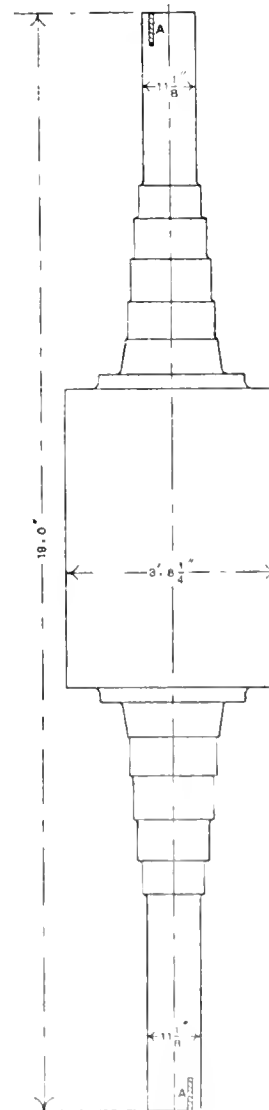

FIG. 4. LARGE ROTOR SPINDLE.

and the following tests refer to the corresponding letter in Fig. 3:—

In the heat treatment of this job, and of jobs having similar shapes, when the

11 hours 30 minutes, and kept at heat for two hours.

Fig. 3.	Yield-Point.		Ultimate Stress. Tons per sq. in.	Elongation on 2 ins. Per cent.	Reduction of Area. Per cent.	Fracture.
	Tons per sq. in.					
A	28.1	46.2	46.2	28.0	52.4	Silky fibrous. (10% fibrous. (90% fine gran.
B	27.9	46.0		27.0	44.4	
C	27.2	46.6	46.6	25.0	47.2	(40% fibrous. (60% fine gran. (30% fibrous.
D	26.4	46.0		26.0	42.0	
E	26.8	46.2	46.2	27.0	44.4	(70% fine gran. (50% fibrous. (50% fine gran.

These results are satisfactory according to the test specification, and show the improvement effected by slight changes in the method of manufacture. The improvement due to rolling to a smaller thickness alone was seen when first material containing 0.53 to 0.54 per cent. carbon was rolled down from 11 inches to 5½ inches, and then retreated in the same manner, for it gave the following tests:—

forging is put into the furnace, the time taken to heat up the heavy centre section is much longer than the time taken to heat up the end sections. For instance, the end-pieces of 11 inches diameter could be heated up in about 4 hours, while the centre would take about 20 hours to reach the same heat, so that before the forging would be uniform the end-pieces would have been at their best for 16 hours, and would have grown

A very troublesome feature of large forgings which have been heat-treated is the distortion which takes place, due to internal stresses probably set up by the operation of quenching. On machining the forging, and especially on removing the outside surface, these stresses are partly relieved, and the forging distorts and takes up a new shape under the influence of the forces still left in the material, so that it loses straightness and generally adds very largely to the time occupied in machining. It is advisable on this account to rough-machine the forging after treatment, and then to re-anneal it before the final treatment is done. Allowance for this re-annealing can be made on the first testing, and where the final machining is intricate and accurate, it will be found to well repay the cost, since trouble in the machine shops due to distortion will be reduced to a minimum.

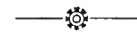

Hardening Nickel Steel Rifle Barrels.

—The temperature generally used for hardening nickel steel rifle barrels is 1500 to 1525 degs. Fah.; and for manganese steel from 1475 to 1500 degs., but has to be varied, according to the chemical analysis of the different steels from which the barrels are to be made, says the *Iron Age*. The barrels are brought up to the required temperature in about one to two hours, depending upon their number and the heating factor of the furnace, and then allowed to soak at that temperature for a similar length of time, after which they are quenched in a tank of oil. The quenching solution, being oil, is not liable to crack or warp the barrels, and it should be kept at a constant temperature of from 70 to 100 degs. Fah.



Concerning Spring Steel.—Spring steel is said to become brittle when used as cathode in a hot cyanide solution, either sodium cupro-cyanide or simple sodium cyanide. The effect is more pronounced with the simple salt. Brass and phosphor-bronze are not affected. Brittleness is not produced by the liberation of hydro-

—	Yield-Point.		Ultimate Stress. Tons per sq. in.	Elongation (ratio length 10). Per cent.	Remarks. Ins. thick.
	Tons per sq. in.				
Length	26.3	44.9	44.9	15.8	5½
Cross	25.7	44.2		16.5	5½
Cross	23.6	42.3		14.0	11

This result could have been still further improved by decreasing the thickness to 3 inches, but it shows how important the effect of work is on carbon-steels, and how it may make just that difference between success and failure.

such a crystalline grain in consequence that any good effect of the oil treatment would have been annulled. To avoid this, the ends were covered with asbestos sheets, leaving only the centre exposed when the forging was charged into the furnace, and this sheeting was removed after 15½ hours in the furnace, so that the forging attained its heat uniformly as a whole, and the crystal grain in consequence was uniform throughout.

For high-tensile material—that is, material over 40 tons strength—where the factor of safety is limited owing to the special conditions under which the material has to be employed, it will generally be safer to use an alloy steel, since for the same tonnage a very much tougher material can be developed; but, for material whose tensile strength is below this figure, there is not the same necessity, and excellent results can be obtained from oil-treated low-carbon steel.

The test results obtained were very good, and are given below. A refers to length tests taken, one from each end of forging, B to tests taken circumferentially from a ring taken from the centre part after treatment, and C to tests taken radially from the same ring. In both B and C tests two tests were taken from opposite diameters:—

Fig. 4 indicates the outline of a large rotor-spindle which was made to the following test specification:—

Yield-Point 20 tons per sq. in.
Ultimate Stress 36 tons per sq. in.
Elongation on 2 ins. . . 24 per cent.

Fig. 4.	Yield-Point.		Ultimate Stress. Tons per sq. in.	(on 2 inches). Per cent. Elongation
	Tons per sq. in.			
A	22.6	38.8	38.8	27
B	22.8	39.2		27
C	22.8	39.2		28
C	22.4	38.8	38.8	28
	22.4	35.8		30
				24

It will be seen from the drawing that the largest diameter was 3 feet 8¼ ins., and the minimum diameter only 11¼ ins., so that if such an ingot were used as would give the requisite amount of work for the largest section, the amount of time and money spent in forging down this ingot to 11 inches would be out of all proportion; and so in this case, as in many other cases, the best metallurgical conditions are incompatible with the best commercial conditions, and a compromise has to be effected. An ingot 60 inches in diameter was used of the following composition:—

The treatment given to this rotor was as follows:—

(1)—Heated to 800° C. (1,472° F.), for 2 hours and cooled in oil.

The centre part attained its heat in 19 hours 30 minutes, and the ends were uncovered after 15 hours 30 minutes, so that they attained their heat simultaneously with the centre part.

(2)—Heated to 550° C. (1,022° F.), in

gen on the steel. The carbon content is not changed by the electrolysis. The crystalline structure is not changed by electrolysis. The brittleness is not produced in annealed wire; the brittleness is produced by use as cathode whether the wire is coiled or not bent in any way. The brittleness is not produced when the wire is used as anode, or when it is suspended in the solution without the passage of electricity.

C.	Mn.	Si.	S.	P.
0.38	0.89	0.21	0.029	0.044

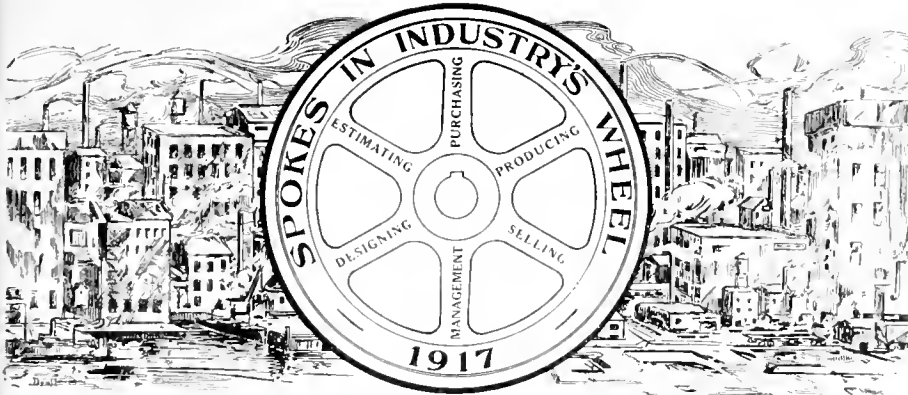

The constitution of industrial enterprise is largely departmental—"spokes in a wheel." This series of articles has for its object the featuring in a racy, interesting and instructive fashion, the training, experience and achievement of those who to-day are transmitting, effectively, energy in their capacity as "spokes in the wheels" of our metal-working establishments.

R. A. GURNHAM

DURING the past few years the fame of Canada has spread with increasing rapidity to all sections of the globe, and the commercial and industrial gates of this promising country are ever widening to provide for the greater volume of business that continues to flow in either direction. In common with every other country, the Metropolis generally becomes the transmission station through which the greater portion of the nation's energies or resources are distributed. Many good things and many evil things have been said of the Island City of Montreal, but while this cosmopolitan town may have its drawbacks, the subject of this sketch is, we trust, not one of them.

Robert Allan Gurnham, works superintendent with the John McDougall Caledonian Iron Works, Ltd., Montreal, was born in Montreal, May 25, 1886. Like many another good Canadian, Mr. Gurnham is proud to say that his ancestors are of good old British stock, both parents being of English origin; his mother born in the garden county of Kent and his father in Surrey County. Realizing the greater opportunities of a new country, both parents came to Canada in the year 1869.

Following his boyhood training in the public schools, "Bob" continued his education, as far as University Matriculation, in the Gault Institute of Valleyfield. The attraction of the engineering profession, however, soon induced our youthful "Spoke" to aspire to a knowledge of its practical side, and, at the age of fifteen, he entered the drawing office of the Northrop Iron Works at Valleyfield, serving three years apprenticeship with that firm. Wishing to acquire a wider experience in mechanical "adventure," R.A.G. commenced to hit the trail, his first stop being in the City of Montreal, where he became junior draughtsman to the Sleeper Engine Works. After being a "sleeper" for one year, he engaged with the C.P.R. car department, as one of the junior draughtsman, filling this position for

one year. Following his railroad experience, Bob carried his kit to the John McDougall Caledonian Iron Works, and occupied the stool of a mechanical draughtsman for a period of two years. With the wanderlust still upon him, he took a position as mechanical draughtsman with the Hart-Otis Car Co., remaining with this concern for one year. During this period of practical concentration, our "Spoke" was also busy acquiring the technical essentials necessary for the attainment of the higher goals. While we cannot truthfully say



ROBERT ALLAN GURNHAM.

that he was making prohibitive use of the midnight oil, he nevertheless spent a fair proportion of his spare time in home study, having graduated in Mechanical Engineering at the American School of Correspondence in the year 1908. About this time he accepted a position with the Canadian Buffalo Forge Co., as chief draughtsman for one year; following which, he moved to Ogdensburg, N.Y., where he had charge

of design and installation of special steam steering gear for the Century Engineering Co., remaining with this firm also for one year. Whether the attraction of his home town was greater than those of foreign fields, or that his "annual" had been completed, is not known, but we next find him back in the Canadian metropolis, as chief draughtsman for the John McDougall Caledonian Iron Works. After five years directing the engineering department, he was promoted to his present position of works superintendent.

Although a Conservative in politics, Mr. Gurnham's present duties do not permit him to take other than a passive interest in the "Affairs of State," although he is ever ready to support his inherent convictions. He is by religion an Anglican, and is also a member of Valleyfield Lodge, A. F. & A. M.; also belonging to the Canadian Order of Foresters. To renew the worn out tissues, our "Spoke" spends his recreation period in motor boating and canoeing, on Lake St. Francis. His military experience has been confined to a summer course with McGill C.O.T.C.

Among the more important undertakings with which Mr. Gurnham has been connected, was assisting at the design and installation of the heating and ventilation of the Princess Theatre, new Windsor Hotels, St. Annas School and Olier School in Montreal; also assisting in the design, installation, and operating tests of two-12 million gallon pumps, and two-30 million gallon pumps, for the City of Montreal. In keeping with the times however, the past two years and a half have been fully occupied by our "Spoke" in the active participation of shell making; the firm of John McDougall having been one of the first to engage in the production of 4.5 inch high explosive shell. Barring the ground covered in acquiring his engineering experience, Bob has not travelled extensively, his range being confined to short trips to the States, and business trips East to Halifax and West to Port Arthur.

Feeling the loneliness of a bachelor existence, Mr. Gurnham, in the year 1916, married Miss M. E. Tardif of Perce, Gaspé County; the couple taking up their residence at 376 Claremont Ave., Westmount.

Speaking of his engineering experience, Mr. Gurnham says "I cannot emphasize too highly, the necessity in our public schools, of giving our youth an opportunity of studying vocational training with the idea of preventing the forcing of square plugs into round holes in business life. I also think that every young mechanic or professional man should keep fully posted in his own particular line by a close study of the latest methods and equipment, by subscribing to and carefully studying at least one reliable technical or trade paper.

PAINT AND IRONWORK

By D. S. L.

IRONWORK enters to so great an extent into the construction and embellishment of buildings, that its proper treatment with paint is a matter of greater moment to the painter. He has to improve its appearance, as well as to protect it. Iron is very susceptible to the action of oxygen, or, in plain words, it soon rusts, and yet, since it is so much used for outside work, it is constantly exposed to the action of damp and changes of temperature. When used for the outside of buildings it requires, therefore, to be protected both from oxygen and from damp. The paint applied to it also requires protection from the action of light and from acid vapours. Consequently several qualities are requisite in paint applied to ironwork. The paint should cling, and not be liable to chip and peel off. It must not corrode of itself, whilst it should be hard enough to resist damp; still it must be elastic enough to withstand the action of different temperatures on the iron, expanding and contracting with it. It must resist water and damp, acids and hard wear.⁴

The pigment used must not be capable of affecting the iron itself. The vehicle mixed with the pigment should be able to protect the iron and to resist outside influences—damp and wear, changes of temperature, and deleterious gases. Those colors which have been subjected to the greatest amount of heat in their manufacture, or in other words, are highly oxidized, are the best for outside work, such as Indian red, Venetian red, and red lead. A red lead priming with a finishing color formed of a pigment mixed with varnish is the best for ironwork. Red-lead is by far the best possible priming for ironwork. When repainting the ironwork there is no need to attempt to scrape off the red-lead, for it clings to the iron firmly and does not scale, blister, or powder. Red-lead makes a first-class aquatic cement when mixed with glycerine—it is, therefore, an excellent paint for railings, bridges, glass houses, and other work that is much exposed to the ravages of variable climates.

Litharge stands next to red-lead, and behaves much in the same way, but it is not so full of body. Neither red-lead nor litharge requires driers, but litharge is only used as a drier. The reason for using red-lead is that it chemically hardens when only the requisite quantity of good oil is mixed with it. It then forms a lead soap, insoluble in water or air, and does not decompose anything it comes in contact with.

Red-lead mixed with two-year-old cold-pressed linseed oil, applied directly it is mixed (that is, before saponification has set in), will preserve iron for many years from rust. The first coat of red-lead does not completely fill up the pores; the second coat will do this, besides producing an enamel-like surface. The next staple color to these is turkey umber with raw linseed oil, which requires driers; with boiled oil the paint

is liable to crack, blister and peel off. For interior work, alizarine, purpurine, bismarck brown, and several of the new permanent aniline colors might be used. Oxide of manganese may be used with the red-lead for a finishing coat. The black of the manganese combined with the red of the lead will form a chocolate, or it may be used with the oxides as a drier, and thus give a select tone of color too. Vermilion is a color which with stands heat and moisture. It is a sulphide of mercury, and is not affected by sulphuric acid vapors, and it does not scale or crack, unless the pigment is either mixed with bad oil or is adulterated. It must be painted flat and varnished afterwards, as oil itself does not agree with it. An iron black may be made from ground sulphate of iron. The oxides vary from a deep scarlet to a dark violet. The above-mentioned pigments give a range of colors that, being of similar nature, will mix without detriment. If a good priming is secured, say of red-lead, a range of permanent color of the same nature, protected with varnish, will give permanence, and a few brilliant colors will give a decorative effect. Such colors are necessary, for instance, for application to the ornamental ironwork of churches, for the banisters or rails of staircases, etc.

Objection has been raised to the oxides of iron, the opinion being ex-

powders. Zinc-white, whenever used, requires more oil or binding than white-lead.

Iron must be thoroughly cleansed before being painted. One plan is to submit it to the action of water containing from one to two per cent. of sulphuric acid, then rinse with cold water, afterwards scouring with dry sand, and finally brushing the sand thoroughly away. Wire brushes are useful for ironwork. Paraffin oil well scrubbed in, will cleanse iron. A coat or two of varnish greatly helps to give permanence and lustre to iron. Encaustic varnish is used for inside work; it does not show up the inequalities of the ironwork, and imparts a refined appearance, but is never used for outside ironwork.



TROUBLE WITH SHAFT BREAKING

A CORRESPONDENT submits the following account of trouble through breakage of a shaft. We have a line shaft about 70 ft. long, which delivers a total horse-power of approximately 300, taken off the various pulleys in the directions shown in sketch. The shaft is driven by ropes received by a pulley on a 7ft. length of 3 15-16 in. shaft. The other shafts are respectively 3 3/8 in. x

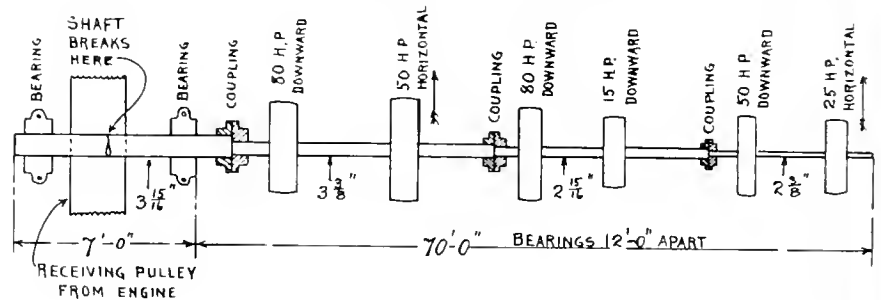

LAYOUT OF SHAFT WHICH GIVES TROUBLE THROUGH BREAKING.

pressed that, rust being an oxide of iron, these colors will only serve to still further oxidize the iron. Experience proves, however, that Indian red, Venetian red, etc., which are made at so high a temperature, stand very well, although they are not so preservative as red-lead, which excels all other pigments for ironwork. White-lead is slightly soluble in water. With the help of carbonic acid in damp places, it sets the iron rusting. Iron has a stronger affinity for oxygen, thus forming rust underneath the paint. White-lead has but little affinity for oil, is unable to resist the slow action of ammonia and damp, and has a tendency to oxidize the oil too quickly. The darkening of oil paint is explained by the fact that oil partly takes up oxygen from the pigment, thus burning or charring it. Zinc-white is not suitable for outside work; it is liable to scale, and does not unite well with the oil. It takes up carbonic acid from the air, and soon

30 ft., 2 15-16 in. x 25 ft. and 2 3/8 in. x 15 ft., the bearings being about 12 ft. apart. The rope drive is from a corliss engine and revolves the shaft at 290 revs. per min. Considerable trouble has been experienced through the 3 15-16 in. shaft breaking in the centre of the pulley hub, and has been repeatedly checked up for alignment without any defect therein. Any suggestions by readers would be appreciated.



White Castings for Motor-car Work.—

A mixture which has given satisfaction for motor-car fittings, and which can be polished the same as nickel-plated work, is as follows:—Copper, 50 lbs.; zinc, 35 lbs.; nickel, 15 lbs.; aluminum, 2 oz. The copper may be increased to 55 lbs., when the resulting castings are very hard and white.

STEEL INDUSTRY DEVELOPMENTS

The War-Created Stimulus given the Steel Industry is Reflected alike in the Nature and Application of New and Improved Equipment being Installed and Developed.

CLEANING BLAST FURNACE GAS*

MARKED differences in opinion have been expressed by engineers interested in cleaning iron blast furnace gases for use in hot-blast stoves and under boilers, with reference to the advantages of a hot-dry method compared with a cold-wet method.

One point at issue involves the sensible heat energy in the moisture contained in the gas. Some advocates of the cold-wet methods claim that the condensation and resultant removal of the greater portion of this contained moisture by wet scrubbing, spraying or similar method, results in a saving of some of this sensible heat energy, because water vapor has a high capacity for sensible heat energy and may carry from the exit of a hot-blast stove, for example, more heat units than are sacrificed or lost when the gas is cleaned by this cold-wet method.

Other advantages claimed for the latter method are: That gas burns more readily when it is free from moisture in any form; that, because gas is made denser by cooling and removing the moisture, it has a higher calorific value than hot gas carrying moisture; and that higher flame temperatures are obtained when the gas is cleaned by the cold-wet method.

Gas Heat Energy

The total heat energy in a gas includes the heat which may be developed by combustion (chemical energy), the heat due to the temperature of the gas (sensible heat), and the latent heat vaporization. The first type of energy may be called "the heat energy of combustion" and the second type "the sensible heat energy" of the gas. The heat energy of combustion is a function of the composition of the gases. For a definite composition of gases it is practically constant and can be readily calculated. The sensible heat energy of a gas depends upon the quantity of gas, the volume and temperature of the gas and the mean specific heat of the gas. The specific heat of a gas in turn depends upon the temperature of the gas and its chemical composition.

In this discussion one pound of a typical dry, clean top blast furnace gas is taken as the unit. It is assumed to have the following percentage composition by weight: CO₂, 21.00; CO, 24.00; H₂, 0.25; CH₄, 0.25; N₂, 54.50. The presence of moisture, dust and excess air is measured in terms of the quantity of this foreign material per pound of such dry, clean top gas. The sensible heat energy of moist, top gas is, therefore, according to our method of calculation

the sensible heat energy of one pound of dry top gas plus the heat energy of the moisture which accompanies, and is in addition to one pound of the gases which constitute the dry top gas; that is, the heat energies are added together.

Moisture Measurement

In practice, the amount of moisture or dust in a gas is frequently measured in grains per cubic foot of gas. This method of measuring the moisture or dust content of a gas usually assumes that the moisture or dust is computed at a certain temperature of the gas such as 32 degrees Fah. Thus, taking one pound of dry top gas with 20 grains of dust per cubic foot of gas calculated at 32 degrees Fah. and 50 grains of moisture per cubic foot of gas calculated at 32 degrees Fah., the unit of gas would contain 0.034994 pound of dust and 0.087485 pound of moisture. The unit of gas considered would consist of a total of 1.122479 pounds of matter, and a calculation of the sensible heat energy of one pound of dry, clean top gas with the above moisture and dust content would involve the calculation of the sensible heat energy of 1.122479 pounds of matter.

This article, however, compares two methods of cleaning, the dry-hot and the cold-wet methods. Since both methods presuppose the removal of dust, it is not necessary to consider the sensible heat energy of the dust. In the example just cited the sensible heat energy would be calculated for 1.0487485 pounds of matter, the dust being excluded.

In the example given in the preceding paragraph the amount of dust and moisture per actual cubic foot of gas decreases with rise in temperature, because the gas expands. At atmospheric pressure one cubic foot of gas at 32 degrees Fah. will become two cubic feet at 523 degrees Fah., and in the example of moist, dusty gas, the dust content of 20 grains per cubic foot of gas calculated at 32 degrees Fah. will fall to 10 grains per actual cubic foot of gas at 523 degrees Fah., while the moisture content will fall from 50 grains per cubic foot, calculated at 32 degrees Fah., to 25 grains per actual cubic foot at 523 degrees Fah., though the percentage of dust and moisture per pound of dry, clean, top gas has remained the same. The measurement of the density of dust and moisture in a gas is, therefore, made by calculating how many grains of each a cubic foot of gas would contain if reduced in temperature to 320 degrees Fah., the pressure being standard at 760 millimeters of mercury.

Air Addition for Combustion

For purposes of combustion it is necessary to add a certain minimum weight of air per pound of the clean, dry top gas. After combustion the chemical

composition and the specific heats of the gases have been completely changed. The datum point will be taken as 60 degrees Fah., and the sensible heat energy of the exit stove gases will be the amount of heat energy that the products of combustion of one pound of dry top gas plus the specified excess air plus the specified moisture entering the stove with the gas and air would emit when cooled from the specified temperature of the exit gases down to 60 degrees Fah. In these calculations it will be assumed that the moisture content of the stove exit gases is not great enough at any time to result in condensation of any of the water vapor at the temperature at which the mixed gases actually leave the stoves. In practice, the moisture content would seldom if ever reach such an amount.

Latent Heat of Water Vapor

The latent heat of the water vapor need not be considered because it is lost in any cleaning method which can be adopted. In the cold-wet method the latent heat of the water vapor is absorbed by the water used during the washing process, and is thus carried away by it; in the dry-hot method the latent heat of the water vapor is carried out with the stove exit gases and thereby lost.

Further, in using 60 degrees Fah. as the datum point for calculations of the sensible heat energy of the exit stove gases or of the blast furnace top gas after coming from the cleaner, it will be assumed the gas contains 5 grains of moisture per cubic foot of gas calculated at 32 degrees Fah. This means that the sensible heat energy is referred to that of the same gas practically saturated with moisture at 60 degrees Fah. Such a datum point is convenient because any kind of a gas cleaned by the cold-wet method usually comes out at about 60 degrees Fah. and is practically saturated with moisture. As our comparison is made between a dry-hot and a cold-wet method of cleaning, it is natural to assume conditions prevalent in the cold-wet method as the datum point.

Consider one pound of dry, clean, top gas at 700 degrees Fah., containing 20 grains of dust and 25 grains of moisture, both calculated per cubic foot of gas at 32 degrees Fah. Our unit of dusty and moist gas weighs 1.078736 pounds. It is found that the sensible heat energy in the one pound of top gas and that in the moisture (which would be lost if the gas passed through a cold-wet cleaning apparatus, thus reducing its temperature to 60 degrees Fah.) would be 174.69 B.t.u. Qt. By the cold-wet method of cleaning that cools the gas to 60 degrees Fah., the above 0.7 units of heat energy are lost for every pound of dry top gas, plus a specified moisture density.

*From a paper presented at the meetings of the American Institute of Mining Engineers, New York, Feb., 1917, by L. Bradley, H. D. Egbert and W. W. Strong.

In the dry-hot method of cleaning, no material lowering of temperature of the combustible gases for the stoves need take place. This condition is practically feasible when the electrical method of cleaning is used because the electrical precipitators need not be more than 15 or 20 feet in length. The length of the gas mains and connections need not, therefore, be greatly increased, and, furthermore, they may be insulated so as to conserve the heat energy of the gases.

In the dry-hot method of cleaning the 25 grains of moisture per cubic foot of gas remain in the gas and are carried into the stoves and then out with the products of combustion. The only difference between the exit gases from dry-hot cleaning and cold-wet cleaning is that in the one case there are 20 grains of moisture per cubic foot of gas standard more than in the other case. Let us assume that the exit gases leave the hot-blast stoves at 600 degrees Fah., which is a fair average. With the hot-dry method of cleaning these gases will carry away 8.83 B.t.u. of sensible heat energy for every pound of dry top gas over and above what the same gases would have carried out had they been cleaned by a cold-wet method, due to the greater amount of moisture left in the gas when cleaned by the hot-dry method. Let this energy be Q_e . The saving in sensible heat energy by the hot-dry method of cleaning as compared to the cold-wet method is: $Q_t - Q_e = 174.6 - 8.83 = 165.86$ B.t.u. per pound of dry top gas.

In the above comparison any energy changes due to expansion or contraction of the gases can be neglected because the exit gases are under practically the same condition of pressure and temperature for both methods of cleaning.

Assuming a ton of iron to represent a production of 12,000 pounds of such typical top gas, a hot-dry method of cleaning the gases would conserve: $12,000 (Q_t - Q_e) = 1,990,320$ B.t.u. per ton of iron.

In some ores a considerable amount of compounds of potash, zinc, lead, arsenic, antimony, etc., may accompany the compounds of iron, copper, etc., for which the ore is being smelted. Under present conditions this more volatile part of the ore may be carried away in the top gas. A dry method of cleaning may allow the recovery of certain of these volatile compounds, thus making commercially possible the treatment of a greater variety of ores. At the present time the application of the electrical method of cleaning blast furnace gas from iron ore containing zinc is being developed and other problems similar to this are also under consideration.

Under practical operating conditions, many factors relating to the cleaning process must be considered. A few of these may be briefly discussed. The cold-wet process of cleaning is usually more or less automatic in operation and requires comparatively little attention. Rather large quantities of water are used and considerable power is consumed in handling this water, and in forcing

the gases through the system. The washers are comparatively large and the initial expense of installation is also large. In some instances, a problem arises as to the disposal of the muddy water, it often being illegal to allow this contaminated water to run into the streams, while in other instances water is not abundant and its use for gas cleaning may be prohibitive.

Electrical Method of Cleaning

There is a hot-dry method of cleaning that promises to be very advantageous for the purpose of cleaning these gases. The electrical precipitation processes make use of a high-tension electrical discharge which sweeps out the suspended matter from the surrounding gas. The electrical method does not cool the gas, it precipitates the suspended dust in a dry state, thus making it easy to reclaim this material. The operation is practically automatic and the energy consumption is small.

The cleaning power of the electrical method is said to be practically complete, in many instances being as high as 99 to 100 per cent. The degree of cleaning is greater than that usually obtained by wet methods in general, and is ample for stoves and boilers. Indeed, the results of recent tests have indicated the probability that, even with a single pass precipitator, the gases would be cleaned to the degree required by internal-combustion engines.



ELECTRIC STEELS

By Mark Meredith.

THE war has speeded up in a remarkable degree innumerable developments which were previously hanging fire or proceeding at a leisurely pace. Among these the electric furnace is noteworthy. In the first half of 1914 electric furnaces were certainly being installed here and there in steel works, but in an experimental or very tentative way. The war brought an increased need for alloy and special steels, for steel castings, and also for means of extracting chromium and nickel from the vast quantities of steel turnings containing these alloys, which are being made in the munition shops. For all these purposes the electric furnace has proved itself particularly valuable, and in the last three years the number of electric furnaces in use in the world has increased with rapid strides. According to a recent computation there were on January 1st, 1917, in the United States, 136 such furnaces, in Great Britain 88, in Germany 52, in Sweden 40, in Italy 29, in France 20, in Canada 19, in Austria Hungary 18, in Russia 16, and in other countries 44. In this computation, figures for helliferous countries are probably underestimated, but accepting the list as given, there are now at work in the world 471 electric furnaces producing steel of one kind and another.

The capacity of the furnaces varies greatly, and no precise figures are available for the total rate of output at the present time, but it is estimated on

sufficiently good grounds that within a year or two the world's output will reach 1,000,000 tons per annum. This estimate is for special steels and castings only, melted up from cold charges, but the electric furnace is also being extensively used for the refining of steel charged into the furnace in a molten state, and if this process should prove generally advantageous, the installation of electric furnaces may be very greatly accelerated. The comparatively large number of furnaces in use in Sweden is, of course, accounted for by the fact that the generation of electricity by water power is proceeding rapidly in Scandinavia, a development highly favorable to the use of electric furnaces. This fact has promoted in Sweden the use of electric furnaces for quite another order of metallurgical work—smelting of pig iron direct from the ore. At least seventeen furnaces, with capacities ranging from 3,000 to 6,000 h.p. are at present at work under construction in Sweden in this connection.

An important feature of the electric steel process is that, by means of it, high quality steel can be produced from materials of a much lower grade than is possible by any other process, so that even though the cost of current exceeds the cost of fuel, it is still possible for the product of the electric furnace to be sold at a competitive price. It remains to be seen how far the electric furnace will be able to hold its own when normal conditions return, but there is every indication that it has taken a permanent place in the process of steel manufacture.



By-Products Recovery.—Nearly all modern by-product oven installations recover their benzol, toluol, etc., in the form of 65 per cent. crude benzol. In former days this crude benzol was transferred at once to the washer and from thence to the rectifying still, whence 90 per cent. benzol, 50/90 benzol, toluol, and naphtha were produced. The modern practice is, however, to distil this unwashed crude benzol in a still of simple construction, and to separate an unwashed benzol fraction, an unwashed toluol fraction, and an unwashed naphtha fraction, the residue being run into a pan where the naphthalene solidifies out on cooling. The benzol fraction will be the first distillate up to the point at which the product at the delivery gives its first drop at about 105 deg. Cent., and the toluol fraction the second distillate up to the point at which the delivery product gives its first drop at about 124 deg. Cent. These three partly rectified, unwashed fractions are accumulated in separate tanks, and are in due course blown or pumped separately to the washer, where the material is agitated first with acid and then with caustic soda.



"Say pa, I het Bobby Smith ten cents to-day that you could lick his dad in fifteen minutes—so be sure and keep Saturday afternoon open."

FRICION AND LUBRICATION OF SHAFTING

Vulcan Staff Article.

MACHINERY and shafting in general, including the fittings, principally comprises details which are in sliding contact with each other. If clean metallic surfaces are placed in absolute contact, and one part slid over the other, excessive friction is developed, by which serious resistance to motion is caused, and the surfaces are wasted by abrasion. In order to minimize frictional resistance and to prevent wear (or to reduce this to a negligible amount), the use of a lubricant is adopted in such a manner as to effect a definite separation between the surfaces, although, at a glance, they appear to be in contact with each other. The lubricating agents commonly adopted are oil or grease in various forms and conditions; also soap, tar, and other fluid, semi-fluid and more solid substances.

Lubricant Action

The film of lubricant acts in much the same way as a series of infinitely small friction rollers. Obviously the accuracy of action, and, therefore, the efficiency of the result, must depend upon the perfect accuracy of the fitting of the mechanical surfaces in each particular case. In connection with a shaft rotating at a high speed, the two surfaces, convex and concave, must be true to circular form. In practice a plain shaft, as left by the turning tool, is not necessarily circular in cross-section, for various reasons connected with the operation of turning in the lathe. Such a shaft is invariably finished by polishing in which a stationary surface of emery is applied, but this cannot effect any improvement in regard to circularity. Careful grinding of the shaft will, however, correct the circularity of the surface; with this object the shaft should be slowly rotated and the cutting effected by a rapidly-rotated wheel of emery or other abrasive material.

Obviously, the ultimate accuracy of the work depends, not only upon the skill and attention of the workman, but also upon the accuracy of rotation of the shaft (preferably upon hardened and ground centres), and upon the truth of rotation and freedom from vibration in connection with the revolving grinding wheel. The matrix or bearing surface by which the shaft is supported should also present an accurate surface, and where the matrix is of hard material it is necessary to adopt measures corresponding to those applying to the shaft. If, however, bearings of soft white metal are adopted, the surfaces of these will adjust themselves by wear in a comparatively short time. When the operation of correcting the circularity by grinding is properly conducted, it incidentally removes a thin coating of metal, which may be said to have been loosened or adversely affected in the principal process of turning. This metal may be compared to an infinitely minute coating of velvet, the minute fibres of which are all bent away in the same direction. By the pro-

cess of grinding, a superior surface of solid metal is presented whereby the frictional resistance to motion is reduced and the vibration or deflection of the centre line of rotation is eliminated.

Ground Bearings for High Speed

All bearings which are required to rotate at a high speed should be finished by grinding, as a point of necessity. The amount of advantage to be thus obtained in connection with parts which rotate at a low speed may be correspondingly small; but in all cases, great care should be devoted to an adequate degree of accuracy in the bearings. The bearings of a crank shaft, even if working at a low speed, are of sufficient importance to call for finishing by accurate grinding in all cases in which the contractor possesses the necessary appliances. In the absence of such appliances, the shaft is finished by turning and polishing, and some engineers are strongly of opinion that better results are obtained when these operations are performed with a shaft rotating in the same direction as it will rotate in its ultimate working position. This can only be explained on the assumption that the incipient fibres of metal are pressed aside by a tool, and left somewhat in the manner of a pile on a velvet cloth; as above referred to. Consideration of the foregoing points will assist in the study of any question affecting the resistance to rotative movement in shafting. The same may be extended to movements of surfaces of revolution of any kind, and also to plane surfaces.

Direct Frictional Resistance

The amount of direct frictional resistance in pairs of solid bodies, as developed when one object is laid upon the other and slid along it, is proportionate to the magnitude of the force by which the one is pressed or held against the other. In the case of dry unlubricated surfaces, the frictional resistance is about one-fifth of such weight or force. This quantity is generally given in the form of a fraction, as .20, which is applied to the amount of pressure at right angles to the surface. This fraction is termed a coefficient of friction, and it is largely reduced by the use of a lubricating agent. For all metallic surfaces, plain or revolving, and which are lubricated by anointing with tallow, lard, or olive oil before placing in contact, the coefficient of friction has been found to be from 0.07 to 0.08. In good modern practice, the majority of revolving and sliding surfaces are lubricated with a copious supply of thin oil, whereby the coefficient of friction is reduced to its lowest limits. About the year 1881, B. Tower made a large number of experiments in which the coefficient was brought down to 0.001 or 0.002, equivalent to a fifty-fold reduction upon the results above given.

Types of Shafting Lubrication

The two principal types of shafting lubrication now adopted are by pump supply and by rings. In pump supply means are adopted for the collection of

oil which leaves the bearing, also to conduct it to a pump for return to the bearing so that the oil is used over and over again indefinitely. In the simple case the used oil may be collected in the bottom of a wall box, or equivalent position. This should be effected with due regard to the following points:—

(1)—The collection should be complete without leakage or distribution by spray or otherwise. Most frequently some loss is incurred by faulty fitting or arrangement. This loss is objectionable from an economical point of view. In a closely-proportioned detail, it may involve the exhaustion of the supply of oil whereby risk of heating and serious damage may be involved. Oil which thus escapes is very likely to cause damage to walls and foundations, and almost certainly it presents a most objectionable eyesore.

(2)—The means of collection and pipes by which the oil is conducted to the pump should be so arranged as to avoid deterioration of oil by dust from the atmosphere. Dust from the atmosphere may be excluded by the adoption of screens of sheet steel, well fitted against both sides of the wall box, and such other openings as may exist. These must be arranged for convenience of opening or taking apart whenever required.

(3)—It is an advantage to have a short break in the delivery pipe by which the current of oil can be placed under observation at any time. For this purpose it may very well be protected by a glass tube. This gives an opportunity for observing the quantity of oil delivered, and its condition with reference to clearness and limpidity.

(4)—The collectors should be thoroughly cleaned by scraping and brushing down to the bare iron, so that all surfaces with which the oil can come in contact are clean; also this operation should be extended to any upper surfaces from which foreign matter can possibly drop. This applies more particularly to sand, which, although it may be comparatively soft and easily removed, is often allowed to remain. The same observation, however, applies to hard sand, as this is liable to soften by extended contact with oil, and, moreover, it is at all times liable to detachment by a blow with very serious results.

Ring Oiling

Ring oiling is effected by the use of a ring or endless chain of greater diameter than the bearing. The top brass and the cap of the bearing are arranged so that the rings can lie upon the revolving shaft, and can be driven by frictional contact when the shaft is rotated. The whole arrangement, including the bottom shaft, must be so designed as to allow the ring or chain to be rove along the shaft into its position; or alternatively, the ring or chain may be arranged for division into two parts for placing in position or removing therefrom. The bottom brass is sometimes divided into two to clear the ring, but this is not necessary or desirable. The ring or chain must possess sufficient weight to overcome an amount of friction sufficient to

drive the ring with its load of adherent oil, and also to overcome the resistance of oil in the oil well. The oil well should provide sufficient depth of oil to load the ring without dipping so deeply as to pick up the dregs of oil. In connection with this type of apparatus, the necessity for removal of dirt, sand, and foreign matter generally, as already explained, applies to the fullest possible extent. The cap of each bearing should be so arranged as to give a good view of the oil when passing over the top of the bearing. Here also the view is necessary for estimating the quantity and condition of oil.

A certain amount of cloudiness develops in oil after repeated use. This is principally due to wear of surfaces, but its quantity should be negligible except as to a short period after starting up new work. The amount, of course, depends principally upon the degree of excellence in the fitting and adjustment of bearings whereby the amount of frictional resistance is minimized. Oxidation by atmospheric influence should be kept in mind, although it does not frequently occur with the use of good oil; but, on the whole, it is better to avoid exposure of any considerable amount of oil surface to the air.

Choice of Lubricating Oil

In the choice of lubricating oil, one of the most important conditions is the degree of completeness with which the frictional resistance is eliminated by the use of the oil. As a rule, oil which is supplied for lubricating purposes is not of a character which is prone to oxidation, but an occasional consignment may give much trouble by gumming, which arises in this way. Excessive frictional resistance is often due to excessive viscosity in the oil, which is equivalent to a deficiency in the degree of fluidity most appropriate to the work of the particular bearings in question, and chiefly with regard to the pressure per square inch to which the bearings are exposed and to the surface speed adopted. A heavy load requires an oil of high viscosity. High speed may facilitate the use of thin oil, and thereby effect a reduction in frictional resistance, but any deficiency in the workmanship is attended with greater trouble in case of the high speed.

Cases have been recorded in which a change of oil has been attended with an increase of 15 to 20 per cent. in the amount of power which is required to drive a given quantity of machinery. If the engine happens to be very closely proportioned to its work, the steam and fuel consumption will rise in a proportion distinctly greater than the increase in the horse power. Obviously, if the additional power is confined to the shafting it may be disclosed in the most striking manner by the indication of the friction load, with all machinery stopped. It is, however, improbable that an increase in the power of the amount stated can be incurred on shafting alone, but there is every reason to believe that it is often incurred in connection with the total load, on account of machinery with the

hundreds of thousands of spindles which are used in textile mills.

Power in excess, which is above referred to, is in every case represented by heat which is generated in strictly accurate proportion to the amount of power consumed, and such heat is distributed over the details in proximity to the surface upon which the resistance is developed. Therefore, careful observation by touching the bearings will, in many cases, suffice to show a distinct difference between the moderate heating due to ordinary work, and the excessive heat due to inordinate resistance to motion in bearings, spindles, and other surfaces which are subject to friction.

Excessive resistance is, moreover, often caused by defective alignment of bearings, either originally or as consequent upon subsidence in the ground and foundations. Such variations in alignment may be found either in a horizontal or a vertical direction. Experience appears to show that few large works have the bearings accurately adjusted either as to lines or levels. In this connection a hypothetical example may be taken in a shaft of 4 in. diameter, which is carried in bearings placed at 10 ft. centres, and which is deflected by $\frac{1}{4}$ in. from the accurate line in the middle of a length of 20 ft. This bearing will have an additional load of 394 lbs. imposed upon it by the deflection, and a further counter-load of 394 lbs., which latter is principally upon the two bearings next adjoining the one in principal question, or a total abnormal pressure across the shaft of 788 lbs.

At a speed of 200 revolutions, and with the full coefficient of .075 as appertaining to bearings which are occasionally oiled by manual attention, the loss by abnormal friction becomes serious, amounting to .375 horse-power. This loss is, however, very frequently exceeded by reason of the stiffness corresponding to the shafts of larger diameter, and also by reason of greater derangement of centres. In a recent case, a serious error of this kind was discovered in the second motion shaft of a large engine, as to which evidence shows that the derangement had existed and caused much trouble during many years.

Erection and Correction of Shafting Bearings

In connection with the erection and the subsequent correction of the bearings of shafting, the first point is in regard to the alignment in ground plan, as to which any fair mechanic will have no difficulty in stringing a line along beneath the shaft and straddling the shaft with a plumb-line on each side of the shaft near to each bearing. The levelling of the shafting is attended with more difficulty than the horizontal alignment, on account of the fact that special levelling apparatus is required. Ordinary levelling from one bearing to another by an ordinary straight-edge and with a hand-level is attended with difficulty and loss of much time, and is, moreover, not reliable in its results.

The majority of careful millwrights

when engaged upon levelling over long distances use a water level, the principal elements in which are a long flexible tube and a terminal piece at each end in the form of a glass tube. The apparatus is filled up with water so that the surface shows in both tubes at the same level. This apparatus is very clumsy for use in most favorable conditions. It is difficult to ensure accurate transference of levels from the surface of the water in the tubes to the actual bearings of the shaft, and it is most essential that all possibility of air locks, bubbles, or other interruptions in continuity of water in the tube and connections should be fully assured.

In all ordinary cases, the use of an ordinary dumpy level, as used in survey work and heavy engineering construction, gives, however, much better results, and in a more convenient manner than any water level. In the majority of dumpy levels, the cross lines are given by thin spider webs, which are difficult to adjust in position and are liable to frequent fracture. The writer calls to mind one case, in a work of importance, in which the cross line was carried away by a strong gleam of sunshine and the work consequently stopped, causing great inconvenience. Experience of this kind will account for the reluctance of millwrights in adopting the use of such a level. In good modern instruments, however, the cross lines are given by ruling upon a glass plate, which is beyond comparison more reliable. The use of a dumpy level for this purpose is generally conducted by giving a mark for each bearing, all such marks being accurately placed at the same level. The quantity of shafting and bearings is usually much greater in a weaving shed than in other situations, but the shafting in such positions is, however, more flexible on account of its comparatively small diameter. Very great improvements have been effected by correcting the shafting on results obtained in this way.



NEW COAL WASHING PLANT

THE installation of a new type of coal-washing plant at the Glamorgan collieries, Llwynpia, is being attended by extremely successful results, and is likely to lead to further important developments in the mining industry in the direction of dealing with what is known as "sump slurry," a coal dust previously regarded as waste. By this process the invention of J. M. Draper, of Manchester, material is secured for the production of high quality of coke. During the process of washing practically no coal, it is said, is lost, and dirty coal containing upwards of 27 per cent. of ash can now be washed down to $8\frac{1}{2}$ per cent. and even lower. The machinery at the Glamorgan collieries is practically automatic, and is turning out 40 tons of the finest washed coal per day, whilst the cost of working is low. It can be applied to dealing with the debris in colliery tips, so that there is a prospect of recovering from these huge banks the large proportion of coal which they contain.

PROGRESS IN NEW EQUIPMENT

A Record of New and Improved Machinery and Accessories for the Machine, Pattern, Boiler and Blacksmith Shops, Planing Mill, Foundry and Power Plant

HYDRAULIC SHINGLE FORMING PRESS

THE illustration shows a hydraulic press of 1,500 tons capacity, which has been built expressly for the forming of fireproof shingles from an asbestos mixture. It is a recent product of the Hydraulic Press Mfg. Co., Mount Gilead, Ohio, and will be used by a Japanese manufacturer of asbestos

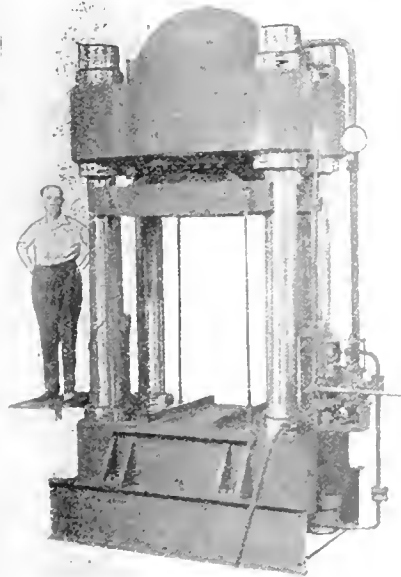

1500-TON INVERTED, ASBESTOS SHINGLE PRESS.

shingles. Interest attaches to the method of pressing these shingles, which requires the special equipment shown in the illustration. The asbestos, after being thoroughly mixed with other ingredients, is formed into layers and placed upon drainage plates. Each plate consists of a steel plate, a sheet of woven wire and a sheet of duck cloth. A number of these plates with a layer of the mixed material to be pressed on each, are stacked upon a steel truck which is then run into the press to receive the pressure for the purpose of extracting the excess moisture and to form each layer to a uniform thickness. The ingredients are also thus pressed into a solid mass. The formed slabs can be used in their original size, 42 inches square, or may be sawed into smaller pieces.

The track running through the press is not attached to the base of the press, but is mounted on a frame, which is supported from above by four rods working through lugs cast on the platen. These rods have lock nuts on their upper ends by which the rods are adjusted to support the track at its proper level. When the platen is at its highest point,

the track is lifted a short distance from the pressure bed. As the platen travels downward, the track is lowered upon the pressure bed, and the platen continues to travel over the rods which pass through the bearings in the platen lugs. The wheels of the truck are so mounted that the bottom of the truck is slightly below the bottom of the track. When the platen starts down, it lowers the four supporting rods with the track, while the truck bottom takes a bearing upon the press base, the wheels being released of all strain during the pressing operation. When the platen is returned, it again lifts the truck from the press base by raising the press track under the wheels and level with the track on the floor so that the truck can be run out of the press.

It will be observed by the illustration that the press is solidly built, steel being used throughout in its construction. The strain rods are made of heat treated forged steel, and are machined to a diameter of 9 in. The heads of the strain rods are forged on. The heads take a bearing against split steel collars. The strain rod lugs on the cylinder and press base being bored, a perfect alignment is obtained through screwed strain rod collars. The press has a pressing surface of 42 in. x 42 in. and a daylight space of 60 in.

All of the operations of this press are controlled by one 2-in. four-way poppet operating valve. The press has two

small push cylinders, which return the main pressure ram after the pressing operation has been completed. These are mounted upon the base of the press between the strain rods. The push rams have a diameter of 5 in. and a run slightly greater than that of the main pressure ram.



PAINT GUN EQUIPMENT

APPARATUS for applying paint and other liquid coatings by means of compressed air has been developed to a point where its use has become synonymous with efficiency, and its field practically unlimited. Included in its range of work are such diversified products as railroad cars and scientific instruments, art metal work and foundry cores, agricultural machines and pianos. The apparatus illustrated herewith is adapted for use in shop, field or laboratory, and may be adjusted for spraying the highest grade of varnishes and lacquers, as well as heavy asphaltum and structural paints, producing finely finished surfaces without streaks or brush marks. It is also adapted for applying heavy durable coatings to rough structures.

The complete equipment consists of the paint gun proper, connected by flexible hose to a portable unit combining in a compact rugged form the material container, air dryer and strainer, pressure control attachment and pressure gauge. After the portable control head has been adjusted to meet the conditions of air pressure, thickness of point, etc. the operator has complete control of the outfit by means of the trigger on the paint gun proper. The gun proper is mounted on a pistol grip, to the butt of which the air and pipe lines are connected. Two adjustments only are necessary: the round cap at the nose, which screws out and in, regulates the amount of material, while the fourled stem at the rear controls the amount of air. The control trigger acts on both air and material, regulating the amount sprayed from zero to maximum. The total weight of the gun is slightly over one pound.

The control head on the tank comprises a pressure gauge, adjustable reducing valve, and air filter and strainer. Where light substances are being sprayed the gun may be connected directly to the air pressure line instead of the tank.

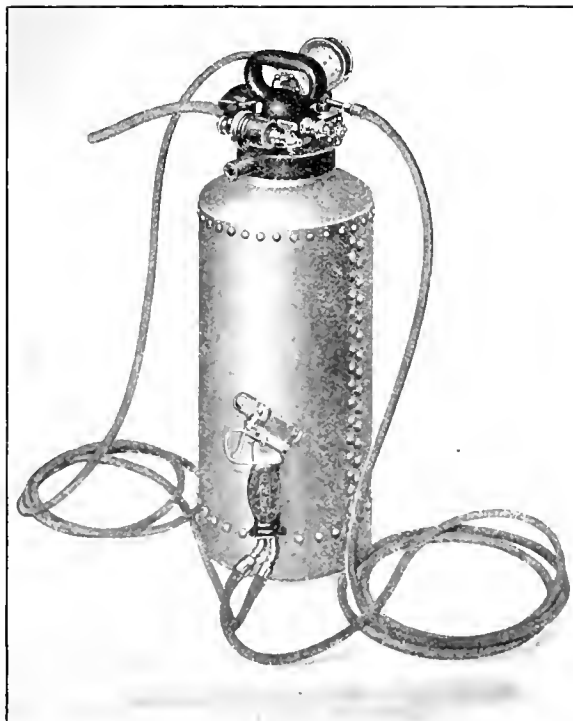

PAINT GUN EQUIPMENT

and the substance in use is placed in an overhead container and fed by gravity. This equipment is manufactured by the Spray Engineering Co., Boston, Mass.



GIGANTIC VOLTAGE REGULATOR

THE accompanying illustration shows what is claimed to be the largest piece of apparatus of its type which has ever been built. It is a self-controlled, induction feeder voltage regulator of the oil-insulated self-cooling type and was recently completed by the Westinghouse Electric & Mfg. Co., East Pittsburgh, Pa., for a large power Co., in the

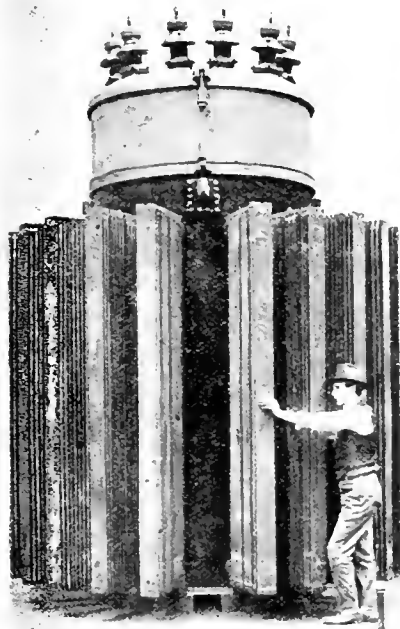

GIGANTIC VOLTAGE REGULATOR.

Southern States. It is rated at 600 k v a., 3-phase, 60 cycles, 13,200 volts, with 10 and 20 per cent. regulation at 262 and 131 amperes, and is designed for operation out doors with full-automatic control self-contained. When installed, the regulator will be connected to the low voltage side of a 6,000 kva. bank of 44,000 to 13,200 volt transformers on the power Co.'s line, and by its use the power from the line will be delivered to the consumer with the voltage maintained continuously at normal value.



CYCLE COUNTER OR TIMING DEVICE.

AS IS generally known, it is not possible to obtain satisfactory results in the testing of time elements of high accuracy relays and of circuit breakers, with a stop watch, particularly where the selective action of the circuit breaker is essential. For this purpose, the Westinghouse Electric & Mfg. Co. of East Pittsburgh, Pa., has developed the cycle counter illustrated, which is a de-

vice for indicating definitely the number of cycles required for the relay to close its contacts.

The mechanism of this timing device consists essentially of an electric self-winding clock, the escapement of which is operated by an alternating current oscillating magnet instead of a pendulum or balance wheel. At each cycle, one tooth of the escapement is released. The self winding clock periodically rewinds by means of power supplied from a shunt connection to the circuit when the cycle pointer has made 60 revolutions, the equivalent of 3,600 cycles. This arrangement keeps an even tension on the escapement. Thus, the escapement magnet is not depended on to drive the indicator, but simply to regulate its speed. The power for driving is furnished by the clock mechanism.

In operation the cycle counter is connected in series with the relay on a circuit adjusted to give the current value at which it is required to test the relay. When the circuit is closed, the "cycle" pointer begins to revolve, one step per cycle, and continues to do so until the contacts are closed. The instrument acts as though it had no inertia; that is, it starts the instant power is applied and stops the instant power closes.

Although primarily designed for use in testing or adjusting time-element relays, this instrument is suitable for a great variety of testing. Its particular field of usefulness is for measuring elapsed time intervals of time too short to be satisfactorily observed with a stop watch and where readings in steps of one alternation are sufficiently accurate, obviating the use of complicated and expensive apparatus such as chronographs or oscillographs.

Given a known frequency the readings can be reduced to seconds if desired. Conversely, by connecting the instrument to a circuit for a definite period of time the frequency can be determined. By adding contacts to ma-

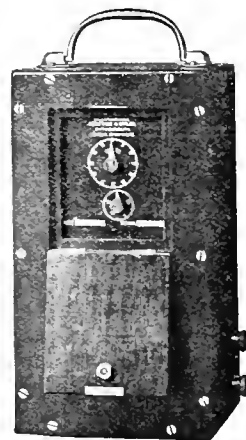

CYCLE COUNTER OR TIMING DEVICE

chine tools, elevator machinery, etc., the time required for various functions can be determined. It will also be found

useful in many laboratories and test rooms for timing purposes.



SPINDLE-DRILLING MACHINE

THE almost universal demand for hollow spindles in lathes and similar machine tools has created a field for machines which are specially designed for deep hole drilling. A drilling machine for work of this class has been placed on the market by Charles Stecher Co., Chicago, and is illustrated in the accompanying engraving.

It is of the inverted type in which the work is placed above the drill to

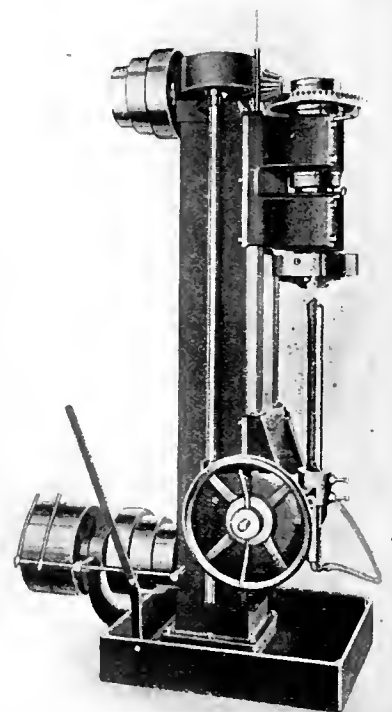

HOLLOW SPINDLE DRILLING MACHINE.

provide free escape for chips, which action is further facilitated by lubricant supplied through passages to the cutting edges by force pump. The work-carrying spindle is mounted on a fixed carriage carried on the face of the main column, and is driven by bevel gearing at its upper end; the lower end carries a chuck for holding the work which may extend to 30 in. in length, above which it is desirable to use an additional chuck on the upper end.

The drill is mounted in a tool carriage, gibbed to the column face and provided with power feed operated by gearing from the upper drive shaft, the feed being varied as required by using gears of suitable ratio. Drive from the pulley shaft is by three-speed cone pulleys. Ball bearings are fitted to both horizontal shafts, and ball-thrust bearings to the work spindle. The principal dimensions are distance, chuck to drill holder, 32½ in.; hole through spindle, 4¼ in. dia.; swing over bed, 14 in.; floor space, 32 x 48 in.; weight, 1,800 lb.

The MacLean Publishing Company

LIMITED

(ESTABLISHED 1888)

JOHN BAYNE MACLEAN - - - - - President
 H. T. HUNTER - - - - - Vice-President
 H. V. TYRRELL - - - - - General Manager

PUBLISHERS OF

CANADIAN MACHINERY AND MANUFACTURING NEWS

A weekly newspaper devoted to the machinery and manufacturing interests.

PETER BAIN, M.E., Editor. B. G. NEWTON, Manager.
Associate Editors.

A. G. WEBSTER, J. M. WILSON, J. H. RODGERS.

Office of Publication, 143-153 University Avenue, Toronto, Ont.

Vol. XVII.

APRIL 12, 1917

No 15.

A POST-WAR PROBLEM OF LABOR

THE introduction of shell manufacture into Canada, created a new phase of enterprise which, up until three years ago, had practically been an unknown factor in this country's industrial activities. The rapid expansion of munitions making, coupled with the drain upon the man power of the land, had the effect of causing a temporary dearth of skilled mechanics in many lines of manufacture. This feature of an unprecedented situation threatened the success of an obligation suddenly undertaken by Canada's captains of industry. During the early period of the war, when the call for volunteers was meeting with a wonderful response, our factories were being depleted of the trained men upon whom much reliance had been placed for the achievement of the new task; that of producing munitions for the Imperial Government.

Time and determination, however, have ever proved the master of circumstances, and while shell makers were confronted with many obstacles during the incipient stages of the undertaking, these very obstacles were eventually the stepping stones by which the desired goal was ultimately attained. The inability to acquire desirable information regarding the manufacture of shell was one of the chief drawbacks to the more rapid development of the new industry, and the first shell makers were forced, to a great extent, to rely upon their own personal experience and perception when equipping their plants for the production of the smaller size yet diverse type shell. Our metal-working firms had never before been called upon to produce on such an extensive scale, besides, little time was permitted to form a plan of action to meet the need. Equipment was apparently the essential factor, and a feverish start was made to obtain the machines most suitable for the purpose. Guided by previous practice in other lines of engineering output, the tools ordered for the new venture were naturally of standard pattern, with few or any of the auxiliary parts eliminated. The urgency and magnitude of the demand for these tools, and the inability of the machine tool builders to deliver equipment, created an unprecedented situation, the result of which has been the means of revolutionizing, not only the shell making industry, but is likely to establish a new standard in future engineering practice.

Probably never before in Canada's history have the resources of plant and individual been more rapidly developed than during the past three years. Instead of the

delay in the delivery of equipment proving a drawback, it has probably been a blessing in disguise. Had sufficient standard tools been readily available at the commencement of the shell game, there is a large possibility that the increased production would not have been as rapid as the changed conditions have proved it to be. Unable to secure standard tools, shell makers began to equip existing machinery with special attachments or devices for the accomplishment of certain operations. Scrap heaps were explored and machines that had been "dead" for years were pressed into service, with such remarkable success that a foundation was started upon which a new and highly efficient line of special single purpose machinery was designed and constructed.

The evolution of modern shell making equipment, from the impromptu attachment to the special purpose machine, has been a great collective engineering achievement, and will likely have considerable bearing upon future manufacturing methods; but the changed status of the workman may create a situation unique in the field of engineering, and one that will require the best efforts of plant executives to solve. Owing to the methods of manufacture, and the development of single purpose tools for specific operations, the problem of unskilled labor has not been as complex as it might otherwise have been, as experience has shown that men, and also women, who had no previous knowledge of machine shop practice, have been equally capable with skilled mechanics in the operation of special machines. The question, however, is: What effect will this have on post-war manufacturing conditions? The knowledge acquired in the operation of machinery by the majority of those now working on munitions, will, when the "game" is over, be a factor that must be included in the problem of future readjustment. It must be conceded that large numbers of present shell workers will class themselves as "mechanists" when the war is over, and normal conditions again prevail.

Where manufacturing is carried on by the separate operation system, the value of machine operators cannot be over-estimated, but the possibilities of domestic production on as vast a scale as the shell making of the past two years, is so very remote, that the services of "shell mechanics" cannot be utilized to the same advantage in normal times. However, the lengthy duration of the war, and the mechanical experience they have gained, both in the operation of machines and the accurate manipulation of tools and gauges, may well fit many of them for a place in future mechanical activities.

The inability to distinguish a mechanic on his own "say so" is often an expensive experience for a factory superintendent. A try-out sometimes proves a complete failure, while a refusal to engage may be equally costly. The remuneration will be an additional inducement for many of these present shell workers to seek positions in the machine shops of the country. Many of these now working in munitions plants were formerly employed at much lower wages than those paid for machine operators in normal times, and from the knowledge picked up during their shell making "apprenticeship," they may imagine they are qualified for a machine shop position. Being deficient, however, in the elementary requirements of machine shop practice, and a general knowledge of the fundamental principles necessary for self-reliance, the average shell "mechanic" would probably "fall down" when given an unusual or complicated job. The cessation of shell manufacture will, therefore, place upon the market a very large number of men, the employment of whom may well prove a difficult post-war problem.

SELECTED MARKET QUOTATIONS

Being a record of prices current on raw and finished material entering into the manufacture of mechanical and general engineering products.

PIG IRON.

Grey forge, Pittsburgh	\$35 95
Lake Superior, charcoal	
Chicago	38 75
Standard low phos., Philadelphia	75 00
Bessemer, Pittsburgh	39 95
Basic, Valley furnace	35 00
Montreal Toronto	
Middlesboro, No. 3	
Cleveland, No. 3	
Clarence, No. 3	
Hamilton	
Victoria	46.50 45.00

FINISHED IRON AND STEEL.

Per lb. to Large Buyers	Cents
Iron bars, base, Toronto	4 25
Steel bars, base, Toronto	4 50
Steel bars, 2 in. to 4 in. base	6 00
Steel bars, 4 in. and larger base	7 00
Iron bars, base, Montreal	4 25
Steel bars, base, Montreal	4 50
Reinforcing bars, base	4 05
Bessemer rails, heavy, at mill	38 00
Steel bars, Pittsburgh	3 75
Tank plates, Pittsburgh	5 75
Beams and angles, Pittsburgh	3 40
Steel hoops, Pittsburgh	4 00
F.O.B., Toronto Warehouse.	
Steel bars, base	4 50
Small shapes	5 00
F.O.B. Chicago Warehouse	
Steel bars	4 25
Bars, 2 in. and up	4 40
Structural shapes	4 50
Plates	5 50

FREIGHT RATES.

Pittsburgh to Following Points	Per 100 lbs.	C.L.	L.C.L.
Montreal	23.1	31.5	
St. John, N.B.	35.1	45.5	
Hallfax	35.1	45.5	
Toronto	18.9	22.1	
Guelph	18.9	22.1	
London	18.9	22.1	
Windsor	18.9	22.1	
Winnipeg	64.9	85.1	

METALS.

Montreal Toronto	
Lake copper	\$39 50 \$40 00
Electro copper	39 50 40 00
Castings, copper	38 50 39 00
Tin	55 50 56 00
Spelter	15 00 14 00
Lead	12 25 12 25
Antimony	28 00 36 00
Aluminum	70 00 68 00

Prices per 100 lbs.

BOILER PLATES.

Montreal Toronto	
Plates, 1/4 to 1 1/2	\$6 50 \$6 50
Heads	6 85 6 85
Tank plates, 3-16 in.	6 00 6 00

WROUGHT PIPE.

In effect April 3, 1917			
Per 100 feet—		Black	Galv.
Buttweld			
3/8 in.	\$ 4 50	\$ 6 00	
1/2 in.	4 26	6 00	
3/4 in.	4 26	6 00	
1 in.	5 36	6 95	
1 1/4 in.	6 97	8 80	
1 1/2 in.	9 85	13 01	
2 in.	13 34	17 60	
2 1/2 in.	15 95	21 01	
3 in.	21 46	28 21	
3 1/2 in.	33 93	41 75	
4 in.	41 37	58 52	
4 1/2 in.	55 20	77 22	
5 in.	65 40	85 57	
Lapweld			
2 in.	24 42	30 90	
2 1/2 in.	36 86	47 09	
3 in.	48 20	61 58	

3 1/2 in.	59 80	76 82
4 in.	70 85	91 02
4 1/2 in.	82 55	106 00
5 in.	96 20	123 60
6 in.	121 80	160 30
7 in.	164 20	208 30
8 in.	172 50	218 80
8 1/2 in.	198 70	252 00
9 in.	238 10	301 90
10 in.	220 80	280 00
10 1/2 in.	284 30	360 50

Prices—Ontario, Quebec and Maritime Provinces.

WROUGHT NIPPLES.

4" and under, 60%.	
4 1/2" and larger, 55%.	
4" and under, running thread, 40%.	
Standard couplings, 1" and under, 50%.	
4 1/2" and larger, 30%.	

OLD MATERIAL.

Dealers' Buying prices.	
Montreal Toronto	
Copper, light	\$24 00 \$23 50
Copper, crucible	28 00 28 09
Copper, heavy	28 00 27 50
Copper wire	28 00 28 00
No. 1 machine composition	23 50 22 00
New Brass clip-pings	19 00 18 00
No. 1 brass turn-ings	16 00 17 00
Heavy Melting steel	17 00 16 00
Steel turnings	12 00 9 00
Boiler plate	15 00 10 50
Rails	17 00 15 00
Axles, wrought iron	22 00 21 00
Rails, wrought iron	17 00 18 00
No. 1 machine cast iron	20 00 20 00
Malleable scrap	15 00 11 00
Pipe, wrought	12 50 9 00
Heavy lead	9 00 10 00
Tea lead	7 50 6 50
Scrap zinc	9 00 10 00
Aluminum	36 00 35 00

BOLTS, NUTS AND SCREWS.

Per Cent.	
Coach and lag screws	30
Stove bolts	35
Plate washers	10
Machine bolts, 7-16 and over	10
Machine bolts, 3/8 and less.	20
Blank bolts	10
Bolt ends	10
Machine screws, fl. and rd. hd., steel	27 1/2
Machine screws, o. and fl. hd., steel	10
Machine screws, fl. and rd. hd., brass	add 20
Machine screws, o. and fl. hd., brass	add 25
Nuts, square, up to 1 in., net list.	
Nuts, hex., up to 1 in., net list.	
Copper rivets and burrs, list plus	30
Burrs only list plus	50
Iron rivets and burrs	27 1/2
Boiler rivets, base 3/4 in. and larger	\$6.60
Structural rivets, as above	6.50
Wood screws, flat, bright	.75
Wood screws, O. & R., bright	.70
Wood screws, flat, brass	.42 1/2
Wood screws, O. & R., brass	.40
Wood Screws, flat, bronze	.35
Wood screws, O. & R., bronze	.22 1/2

MILLED PRODUCTS.

Set screws	35
Sq. & Hex. Head Cap Screws	30
Rd. & Fl. Head Cap Screws	10
Flat 3/8 But. Hd. Cap Screws plus	10
Fin. & Semi-fin. nuts up to 1 in.	25
Fin. and semi-fin. nuts, over 1 in., up to 1 1/2 in.	30
Fin. and semi-fin. nuts, over 1 1/2 in., up to 2 in.	10
Studs	20
Taper pins	40
Coupling bolts, plus	10
Planer head bolts, without fillet	10
Planer head bolts, with fillet	10 and 10
Planer head bolt nuts, same as finished nuts.	
Planer bolt washers	net
Hollow set screws	list plus 20
Collar screws	list plus 30. 10
Thumb screws	20
Thumb nuts	65
Patch bolts	add 40. 10
Cold pressed nuts to 1 1/2 in.	add \$1.50
Cold pressed nuts over 1 1/2 in.	add \$7.00

BILLETS.

Per gross ton	
Bessemer billets	\$65 00
Open-hearth billets	65 00
O.H. sheet bars	72 50
Forging billets	90 00
Wire rods	85 00

F.o.b. Pittsburgh.

NAILS AND SPIKES.

Wire nails	5 00	4 95
Cut nails	4 70	4 70
Miscellaneous wire nails	60%	
Pressed spikes, 5/8 diam., 100 lbs.		5 20

MISCELLANEOUS.

Solder, strictly	0 33
Solder, guaranteed	0 35
Babbitt metals	14 to 60
Soldering coppers, lb.	0 53
Putty, 100-lb. drums	4 00
White lead, pure, cwt.	14 25
Red dry lead, 100-lb. kegs, per cwt.	13 87
Glue, French medal, lb.	0 25
Tarred slaters' paper, roll	0 95
Gasoline, per gal., bulk	0 31 1/2
Benzine, per gal., bulk	0 30 1/2
Pure turpentine, single bbls., gal.	0 49
Linseed oil, raw, single, bbls.	1 40
Linseed oil, boiled, single bbls.	1 43
Plaster of Paris, per bbl.	2 50
Plumbers' oakum, per cwt.	8 00
Packing, square braided	0 27
Packing, No. 1 Italian	0 32
Packing, No. 2 Italian	0 25
Lead wool, per lb.	0 15
Pure Manila rope	0 29 1/2
Transmission rope, Manila	0 37 1/2
Drilling cables, Manila	0 32 1/2

POLISHED DRILL ROD.

Discount off list, Montreal and Toronto 25%

CARBON DRILLS AND REAMERS.

Per Cent.	
S.S. drills, wire sizes up to 52	40
S.S. drills, wire sizes, No. 53 to 80	25
Standard drills to 1 1/2 in.	40
Standard drills, over 1 1/2 in.	15
3-fluted drills, plus	10
Tobbers' and letter sizes	40
Bit stock	40
Ratchet drills	15
S.S. drills for wood	40
Wood boring brace drills	25
Electricians' bits	30
Sockets	30

Sleeves	40
Taper pin reamers	20
Drills and countersinks	1st plus 30
Bridge reamers	45
Centre reamers	10
Chucking reamers	10
Hand reamers	15

COLD ROLLED SHAFTING.

At mill	list plus 40%
At warehouse	list plus 50%

Discounts off new list. Warehouse price at Montreal and Toronto.

IRON PIPE FITTINGS.

Canadian malleable, A, add 10%; B and C, 10%; cast iron, 35%; standard bushings, 50%; headers, 60; flanged unions, 40; malleable bushings, 50; nipples, 55; malleable flpped unions, 50.

SHEETS.

Montreal Toronto			
Sheets, Black, No. 28	\$6 25	\$6 75	
Sheets, Black, No. 10	6 50	6 50	
Canada plates, dull, 52 sheets	7 00	7 00	
Canada plates, all bright	8 00	8 00	
Apollo brand, 10 3/4 oz. galvanized	7 25	7 25	
Quebec's Head, 28 B. W.G.	7 75	7 75	
Fleur-de-Lis, 28 B.W. G.	7 45	7 35	
Gorbals' Best, No. 28	8 25	7 50	
Colborne Crown, No. 28	8 00	6 75	
Premier, No. 28 U.S.	7 75	7 45	
Premier, 10 3/4 oz.	8 00	8 25	

PROOF COIL CHAIN.

1/4 in.	\$9 45
5-16 in.	9 10
3/8 in.	8 35
7-16 in.	7 15
1/2 in.	6 95
9-16 in.	6 95
5/8 in.	6 80
3/4 in.	6 70
7/8 in.	6 55
1 inch	6 40

Above quotations are per cwt.

ELECTRIC WELD COIL CHAIN B.B.

1/4 in.	\$15 50
3-16 in.	11 70
1/2 in.	8 40
5-16 in.	7 40
3/8 in.	6 35
7-16 in.	6 35
1/2 in.	6 35
5/8 in.	6 35
3/4 in.	6 35

Prices per 100 lbs.

FILES AND RASPS.

Per Cent.	
Great Western, American	60
Kearney & Foot, Arcade	60
J. Barton Smith, Eagle	60
McClelland, Globe	60
Whitman & Barnes	60
Black Diamond	50
Delta Files	47 1/2
Nicholson	50
Globe	57 1/2
Vulcan	57 1/2
Disston	60

COAL AND COKE.

Solvay Foundry Coke	
Connellsville Foundry Coke	
Yough Steam Lump Coal	
Pittsburgh Steam Lump Coal	
Best Slack	

Net ton f.o.b. Toronto

BOILER TUBES.			TAPES.		ANODES.		SHEETS, 3½ lbs. sq. ft.	
Size.	Seamless	Lap-welded	Chesterman Metallic, 50 ft.	\$2 00	Nickel	.50 to .54	ft.	16 00 16 00
1 in.\$24 00	Luffkin Metallic, 603, 50 ft.	2 00	Cobalt	1.75 to 2.00	Sheets, 4 to 6 lbs. sq. ft.	15 50 15 50
1¼ in. 30 00	Admiral Steel Tape, 50 ft.	2 75	Copper	.44 to .46	Cut sheets, ½¢ per lb extra.	
1½ in. 32 00	25 00	Admiral Steel Tape, 100 ft.	4 45	Tin	.49 to .56	Cut sheets to size, 1¢ per lb extra.	
1¾ in. 32 00	25 00	Major Jun. Steel Tape, 50 ft.	3 50	Zinc	.25 to .25		
2 in. 35 00	26 00	Rival Steel Tape, 50 ft.	2 75	Prices Per Lb.			
2½ in. 44 00	33 00	Rival Steel Tape, 100 ft.	4 45	COPPER SHEETS.			
3 in. 47 00	38 00	Reliable Jun. Steel Tape, 50 ft.	3 50	Montreal Toronto			
3¼ in. 45 00			Bars, ½ to 2 in.	55 00 53 00	Acid, boracic\$ 15	
3½ in. 50 00	48 00	WASTE.		Plain sheets, 14 oz., 14x28 in., 14x60 in.	55 00 53 50	Acid, hydrochloric65	
4 in. 74 00	60 00	White		Copper sheet, tinned, 11x60, 14 oz.	60 00 54 25	Acid, hydrofluoric14½	
			Cents per lb.		Copper sheet, plain-ished, 14x60 base, 64 00 60 00		Acid, nitric10	
					Braziers', in sheets, 6x4 base	55 00 52 00	Acid, sulphuric05	
					BRASS.			
					Brass rods, base ½ in to 1 in rd.			
					Brass sheets, 8 in. wide, 20 oz.			
					Brass tubing, seamless			
					Copper tubing, seamless			
					PLATING SUPPLIES.			
					Polishing wheels, felt			
					Polishing wheels, bull-neck			
					Emery in kegs, American			
					Pumice, ground			
					Emery glue			
					Tripoli composition			
					Crocus composition			
					Emery composition			
					Rouge, silver			
					Rouge, powder			
					Prices Per Lb.			
					LEAD SHEETS.			
					Montreal Toronto			
					Sheets, 3 lbs. sq. ft. \$16 00 \$16 00			
					PLATING CHEMICALS.			
					Ammonia, aqua08			
					Ammonium carbonate15			
					Ammonium chloride11			
					Ammonium hydrosulphuret40			
					Ammonium sulphate07			
					Arsenic, white12			
					Copper, carbonate, subhy.35			
					Copper, sulphate17			
					Cobalt sulphate70			
					Iron perchloride20			
					Lead acetate16			
					Nickel ammonium sulphate12			
					Nickel carbonate35			
					Nickel sulphate15			
					Potassium carbonate75			
					Potassium sulphide (sub-stitute)20			
					Silver chloride (per oz.)65			
					Silver nitrate (per oz.)55			
					Sodium bisulphite10			
					Sodium carbonate crystals65			
					Sodium cyanide, 127-130%41			
					Sodium hydrate04			
					Sodium hypsulphite, per 100 lbs. 5.00			
					Sodium phosphate14			
					Tin chloride60			
					Zinc chloride60			
					Zinc sulphate09			
					Prices Per Lb. Unless Otherwise Stated.			
OILS AND COMPOUNDS.								
Castor oil, per lb. 27							
Royalite, per gal., bulk 16							
Palacine 19							
Machine oil, per gal. 26½							
Black oil, per gal. 13							
Cylinder oil, Capital 45½							
Cylinder oil, Aeme 35½							
Standard cutting compound, per lb. 6 15							
Lard oil, per gal. 1 45							
Union thread cutting oil antiseptic 68							
Aeme cutting oil, antiseptic 37½							
Imperial quenching oil 39½							
Petroleum fuel oil 12¾							
BELTING—NO. 1 OAK TANNED.								
Extra heavy, single and double 30-5%							
Standard 40%							
Cut leather lacing, No.1 1 50							
Leather in sides 1 35							

The General Market Condition and Tendency

interest of pushing the war to a successful and speedy termination. It is anticipated that similar action will be taken by steel makers as those announced some time ago by the copper producers in the matter of supplying material to the Government. The early future promises some eventful movements throughout industrial circles, both in the States and Canada.

Steel

With the crisis past, and the tension of many months removed, United States interests are now awaiting the decisive action of the Government in developing a plan of operations. Full co-operation is expected between the steel interests and the government; and it is certain that the requirements of the latter will have precedence over all other demands, and on a lower basis than the prevailing market. The entrance of America into the war, will however, not be the means of cutting off extensive supplies of materials to plants now working for the Allied Governments, as it is realized that the best interests of all lie in the furtherance of supplies for existing field forces. It is therefore more than probable that no anxiety will develop among those—steel users who are working on munitions, but it is anticipated that the tonnage now on order for home and export domestic use, may be diverted into other channels more closely connected with the prosecution of the war. Pressure on the plate mills will increase, following the recent declaration and delivery on ship, plates may be extended owing to the urgent needs of British contracts. The rising tide in pig iron would seem to predict

THE situation in industrial circles has not as yet been materially affected by the definite action taken by Congress at Washington, although a more optimistic feeling has resulted. An element of uncertainty has been removed which alone will have a beneficial effect on business. This latest development in the International situation has not in the meantime affected prices of steel products, indications however, point to a continuance of the present upward movement. There has, however, been some talk of regulating prices of steel for the United States and Allied Governments. In what way this would affect the price to the ordinary consumer is problematical. The situation at the mills has improved considerably and production is steadily increasing. Raw materials are moving on the railways in better volume, but manufacturers are still being handicapped to some extent by delayed shipments. The railways are doing better than they were a short time back, but there is a lot of freight to move yet before conditions are normal. Hamilton foundry pig-iron is off the market again on account of the heavy demand for steel making grades. A price of \$45 has been issued on Victoria pig-iron made at Port Colborne, Ont. Prices on most non-ferrous metals are unchanged this week, the market being dull and easy. The metal markets are dominated by the International situation and consumers are awaiting developments. The scrap metal market is quiet and quotations unchanged. The demand for steel and iron scrap is the principal feature of the market. The demand for machine tools continues light, but a number of important price advances have been made by builders in the United States.

Montreal, Que., April 9th, 1917.—The momentous step taken by the United States Government may or may not directly influence the duration of the war and the extent to which it will affect the general market conditions is as yet, problematical. That a very definite

understanding will be arrived at between that country and the nations of the Entente Allies, is certain. One of the first considerations of the new relationship will be a complete readjustment of shipping regulations, to establish the highest co-operation, in the best

higher levels on steel products, and neglecting the effect of the recent American declaration, the tendency is still upward. A favorable feature of the present situation, is the better facilities for handling material, owing to the increased car supply and improved railroad conditions. The early opening of navigation will assist in this connection. Billets and sheet bars are comparatively quiet, consumers being well supplied, and mills busily awaiting the policy of the government. Prices as high as 8c have been asked for tank plates, Pittsburgh. The Pittsburgh quotation on black sheets has been advanced to 6c, this being \$10 higher than last week. Blue annealed sheets, have advanced \$5, the nominal quotation being \$5.50 per hundred. Local dealers expect an early revision of prices. Discounts are disappearing from cold rolled shafting price lists, the most recent advance being a reduction of 10 points, the present discount being about 5 per cent. off list. Heavy demand continues for wire products, while producers of wire rods are still unable to satisfy the trade requirements. Wrought iron pipe has again been advanced, the latest rise being \$10 per ton. These advances are mostly due to the filled up condition of the mills. A practical famine exists in boiler tubes and higher levels are not unlikely. Conditions locally are unchanged but readjustment of prices are under consideration.

Metals

The week has been characterized by slight buying activity, the general disposition being to await further developments of the international situation. Copper has declined as a result of producers' action in regard to government requirements. Tin continues quiet with little trading and easier prices. Spelter and lead responded to increased traffic facilities, spot prices showing a decrease at New York. Antimony showed a decided upward tendency while aluminum grades covered quite a range. No changes are reported locally but some advances are looked for.

Copper.—Quiet prevails in the copper market and little business is being done. This is likely the result of the recent action of the States and nothing of importance is expected until the situation becomes more settled. London is firm while New York has fallen off $\frac{1}{2}$ cent on lake and $\frac{1}{4}$ on electro. The local market is firm and unchanged; lake and electro are quoted at 39 $\frac{1}{2}$ cents and castings at 38 $\frac{1}{2}$ cents per pound.

Scrap

Although the week has been an eventful one politically, the general industrial conditions have not yet experienced any marked change, as a period of uncertainty still dominates the situation. New York prices on old copper are $\frac{1}{2}$ cent higher, and old brass is slightly lower, but local quotations are unchanged on an uncertain market.

Toronto, Ont., April 10.—Events at Washington have occupied the centre of

the stage this week, but the decision of Congress to enter the war did not have very much effect on business locally except that it created a more optimistic feeling. This development was more or less expected and consequently discounted. It is too early to determine precisely what effect this latest development in the international situation will have on business in Canada, but it is difficult to see how it can be anything but beneficial. It will bring the two countries into closer relationship and understanding, an important factor in business dealings during times of peace, and of great moral effect in war time.

Steel

No marked change in the situation in the steel trade in Canada has followed the decision of the United States' Congress to enter the war against Germany. The U. S. Government is understood to be making arrangements with the steel companies for fixing steel prices, which, it is believed, will be considerably lower than the current quotations. Until this question is settled, the market will be unsettled, for it remains to be seen what action, if any, the mills may take in regard to rearrangement of price schedules to domestic and foreign consumers. In the latter category would be included Canadian buyers. In any event, it is difficult to see how prices, particularly for steel for ordinary purposes, other than munitions, can do anything but go higher. The tendency at present is distinctly in an upward direction, and the increased pressure on the mills can hardly fail to force prices up. The continued increase in prices of pig iron is also an important factor in the situation, and is bound to have an important bearing on prices of steel products. The effect of developments in the United States market will be felt by Canadian consumers of steel imported from that country, and not to any appreciable extent by the Canadian steel companies, whose output is largely being taken care of by the Imperial Munitions Board. This feature has had the effect of steadying the trade, although prices have been advancing in line with the U. S. market.

Another sharp advance in wrought pipe of \$6 per ton following a \$4 advance last week makes a total advance of \$10 in practically a week. The higher prices are attributed to shortage and high cost of raw material. The expected advance in rivets has materialized, boiler rivets being now quoted at \$6.60 and structural at \$6.50 per 100 lbs. base. Pressed steel spikes are also higher, being now quoted at \$5.20 per 100 lbs. base. Plates and tubes are very firm at current quotations and higher prices are looked for in the near future. The demand for plates, principally from shipbuilders, continues enormously heavy. Sales of ship plates have been made at 8c mill, an extraordinarily high price, but likely to be eclipsed before long.

Prices of black sheets continue very firm, and a further advance appears to be likely at no distant date, affecting both black and blue annealed sheets. Although production has been materially

increased, the mills are still behind on deliveries. Prices on galvanized sheets are also very firm, with a higher tendency.

The steel market in the United States is dominated by the international situation. The chief consideration for the time being is the extent of the Government's requirements of steel and the fixing of prices. It is understood that substantial concessions will be made by the steel companies to the Government from current prices, but what definite effect this arrangement will have on the market is at the present moment impossible to determine, except that prices are more likely to continue advancing than otherwise. A few price advances have been made during the week. Tank plates are now being quoted at 5.75c Pittsburgh, and Chicago warehouse price on steel bars is now 4.25c, and on structural shapes 4.50c.

Pig Iron

The pig iron market continues very firm, and prices are still on the up-grade. The Steel Company of Canada have turned their No. 2 furnace at Hamilton over to basic pig iron, and have withdrawn prices on foundry iron. Victoria foundry iron is now being quoted at a nominal price of \$45 per ton. The situation at Buffalo is very tight owing to the sold-up condition of the furnaces and very low stocks. Producers are quoting \$41 to \$42 furnace on No. 1 foundry iron.

Scrap

Prices on scrap metals have a weak tendency except on steel scrap and machinery cast iron, which are in good demand. The high cost of pig iron has created an unusually heavy demand for cast iron scrap and caused an advance in price of this material. Steel turnings continue in good supply, with a fair demand. Scrap copper and brass are weaker and the market dull.

Machine Tools

Although the market is quiet, prospects are looking better for increased business. Some makers of 18-pdr. and 4.5-in. high explosive shells have recently purchased some machine tools to balance up their plant for increased production. It is reported that an American concern is anxious to locate a plant in this province and, if successful, a considerable quantity of machine tools will be required. An important development affecting the local market is a number of advances in prices of machine tools recently put in effect by some builders in the United States. The advances include the following tools:—Radial drills and shapers, 10 per cent.; upright drills and power presses, 5 per cent.; and engine lathes, 10 per cent. It is interesting to note that prices on radial drills are now approximately 90 per cent. higher than they were two years ago. Shapers are about 40 per cent., upright drills 50 per cent., power presses 20 per cent., and engine lathes 60 per cent. higher than they were two years ago.

Supplies

There are no important features to note in regard to machine shop supplies

except that business continues very good and prices are holding firm.

Metals

The metal markets this week are generally dull and quiet. The markets are unsettled on account of the international situation, and consumers are inclined to hold back awaiting developments. The decision of the U. S. Congress to take an active participation in the war did not affect metal prices, as was anticipated in some quarters. Locally business continues very good at unchanged prices. The metal exchanges in London and New York were closed from Friday to Monday inclusive for the Easter holidays.

Copper.—Prices continue nominal and unchanged, but the market is unsettled, and there appears to be some doubt as to what may develop in regard to values. The recent low price for copper made to the U. S. Government by the producers has affected the market, and what will be the result on the price situation generally is difficult to determine. Local prices are unchanged, lake and electrolytic being quoted at 40c, and castings at 39c per pound.

Tin.—The market is very dull in New York, with very little business doing, due to the political situation. Prices advanced recently in London, but trading has been light for several days. Local price, 50c per pound.

Spelter.—The market is dull and easier. Consumers are awaiting developments in the zinc ore situation. Spelter is unchanged locally at 14c per pound.

Lead.—There is no change in the situation in regard to lead. Prices are being well maintained, there being no disposition to quote below the "Trust" price. Lead is unchanged at 12½c per pound.

Antimony.—The market continues firm, and prices have an upward tendency. Local price nominal at 36c per pound.

Aluminum.—The demand for aluminum is at present light, and quotations are unchanged at 68c per pound.

OUR ORDERS FROM FOREIGN COUNTRIES GROW

LARGE purchases have been made by the Canadian Department of Trade and Commerce for some of the Allied Governments, according to the annual report of the department, just issued. The French Government late in October, 1914, expressed a desire to purchase blankets in Canada for the French soldiers. The Minister of Trade and Commerce, Ottawa, acting for the purchasing committee of the Cabinet, made the necessary arrangements to purchase the blankets. The Department of Militia and Defence supervised the inspection of the blankets, and the Department of Trade and Commerce made payment therefor on presentation of the necessary certificate of inspection. The order from the French Government was for

400,000 blankets to be delivered at the earliest possible date. Much difficulty was encountered in placing so large an order in Canada, as the Canadian factories were working at full capacity. Canadian factories were given orders to the limit of their capacity, but a portion of the order allotted to Canada had to be filled in the United States. Considerable trouble was experienced in obtaining sufficient ocean transportation from St. John, the port of shipment, but shipments were made as promptly as possible. Orders were placed for over 457,000 blankets, but the mills supplied 406,716 blankets, of a value of \$1,613,000.

The South African Government early in March, 1915, cabled that they desired to purchase 35,000 bags of flour. The Department of Trade and Commerce was charged with the matter, and on March 6 called for tenders from the principal flour mill companies in Canada. A contract was entered into with one of the principal companies for the delivery of flour in New York for shipment to South Africa. The department also arranged for the inspection of the flour at the mill. The shipments were made from New York on March 30 and

CANADIAN GOVERNMENT PURCHASING COMMISSION

The following gentlemen constitute the Commission appointed to make all purchases under the Dominion \$100,000,000 war appropriation:—George F. Galt, Winnipeg; Hormidas Laporte, Montreal; A. E. Kemp, Toronto. Thomas Hilliard is secretary, and the Commission headquarters are at Ottawa.

April 17. The total expenses in connection therewith amounted to \$129,663.

Shirts and Blankets for Italy

In July, 1915, the attention of the Government was directed to the condition of the knit goods industry of Canada. It was pointed out that the mills producing underwear, sweater coats and socks were practically idle and the assistance of the Government was asked in securing orders from the allied governments for a portion of their military requirements. The Minister of Trade and Commerce took the matter up promptly and effectively. Orders were secured from the Italian purchasing commission for 600,000 undershirts and 100,000 blankets. The department undertook the inspection of the shirts and blankets which were sent from the mills to the Italian Government via New York. The department made payment to the mills on receipt of invoices covering the shirts and blankets, supported by certificates of inspectors and certificate of arrival in New York. Up to February 15, 1917, 101,974 blankets were shipped to Italy at a cost of \$335,618, and up to the same date 1,909,624 shirts

had also been sent to Italy at a cost of \$1,946,492, a total of \$2,280,110.

AMERICAN SHIPBUILDING

THE Shipping Board's program of building a fleet of 1,000 wooden ships of 3,000 or 3,600 tons each to meet the loss of tonnage by submarine warfare and thus help to defeat the German undersea campaign has been formally approved by President Wilson. The first ship will be ready within five months, and the board will call upon the Treasury for from \$10,000,000 to \$15,000,000 within the next few days. Fifty million dollars already has been authorized by Congress for the work of the board.

Chairman Denman announced that the board's plans have been virtually completed, and that the preliminaries to the construction of the big fleet were in full swing. Contracts have been let with the builders, arrangements have been virtually completed for the supply of standardized lumber parts, the labor problem has been settled, at least partially, and unless there is an unforeseen hitch, by October the shipyards on the Atlantic and Pacific will be turning out the new vessels at the rate of two or three a day to be leased to private shipping concerns.

The great fleet will fly the American flag, and each vessel sailing to the war zone will be armed. The program calls for the building of two hundred thousand tons of shipping monthly. The builders will be encouraged to complete the vessels speedily, and plans have been made to make partial payments on vessels, where necessary, from month to month. The present program calls for leasing the ships to private firms.

COMMERCIAL DEVELOPMENT OF TECHNICAL BUSINESSES

By Geo. H. Gibson.

THE application of science proceeds at an accelerated pace. The days have about gone by when one good idea would keep a family in business for several generations. No one dare rest content, for as Solomon remarks, "Yet a little sleep, a little slumber, a little folding of the hands to sleep, so shall thy poverty come." Every manufacturer, and particularly manufacturers of engineering appliances and products, must maintain a constant output of improvements and new developments in order to protect their investment in plant, organization, and good-will, and, indeed, to stay in business. As has justly been said, the invention of a new machine or process—by some one else—may be as disastrous as a fire, and far more likely to occur.

Moreover, the more progressive, the more advanced, a concern is, the greater will be its volume of new developments and improvements. Inventions breed inventions. At the same time, the investment of time and money in research and development is a capital risk—that is, the preliminary investigation upon

Enlarged Canadian Trade Intelligence Service

Under the arrangement made by the Minister of Trade and Commerce with Sir Edward Grey in July, 1912, the Department of Trade and Commerce, Ottawa, is able to present the following list of the more important British Consulates whose officers have been instructed by the Foreign Office to answer inquiries from and give information to Canadians who wish to consult them in reference to trade matters.

BRAZIL—Bahia, British Consul. Rio de Janeiro, British Consul General.	NETHERLANDS—Amsterdam, British Consul.
CHILE — Valparaiso, British Consul General.	PANAMA—Colon, British Consul. Panama, British Vice-Consul.
COLOMBIA — Bogota, British Consul General.	PERU—Lima, British Vice-Consul.
ECUADOR—Quito, British Consul General. Guayaquil, British Consul.	PORTUGAL—Lisbon, British Consul.
EGYPT — Alexandria, British Consul General.	RUSSIA—Moscow, British Consul General. Petrograd, British Consul. Vladivostok, British Consul. Odessa, British Consul General.
FRANCE—Havre, British Consul General. Marseilles, British Consul General.	SPAIN—Barcelona, British Consul General. Madrid, British Consul.
INDIA—Calcutta, Director General of Commercial Intelligence.	SWEDEN—Stockholm, British Consul.
ITALY—Genoa, British Consul General. Milan, British Consul.	SWITZERLAND—Geneva, British Consul.
MEXICO—Mexico, British Consul General.	URUGUAY—Monte Video, British Vice-Consul.
	VENEZUELA — Caracas, British Vice-Consul.

Canadian Commercial Intelligence Service

The Department of Trade and Commerce invites correspondence from Canadian exporters or importers upon all trade matters. Canadian Trade Commissioners and Commercial Agents should be kept supplied with catalogues, price lists, discount rates, etc., and the names and addresses of trade representatives by Canadian exporters. Catalogues should state whether prices are at factory point, f.a.b. at port of shipment, or, which is preferable, c.i.f. at foreign port.

CANADIAN TRADE COMMISSIONERS.

ARGENTINE REPUBLIC—B. S. Webb, Acting Canadian Trade Commissioner, Reconquista, No. 46, Buenos Aires. Cable address, Canadian.
AUSTRALIA—D. H. Ross, Stock Exchange Building, Melbourne. Cable address, Canadian.
BRITISH WEST INDIES—E. H. S. Flood, Bridgetown, Barbadoes, agent also for the Bermudas and British Guiana. Cable address, Canadian.
CHINA—J. W. Ross, 13 Nanking Road, Shanghai. Cable address, Cancom.
CUBA—A. T. Quilez, Acting Canadian Trade Commissioner, Lonja del Comercio, Apartado 1290, Havana. Cable address, Cantracom.
FRANCE—Phillipe Roy, Commissioner General, 17 and 19 Boulevard des Capucines, Paris. Cable address, Stadacona.
JAPAN—E. F. Crowe, Acting Canadian Trade Commissioner, P. O. Box 109, Yokohama. Cable address, Canadian.
HOLLAND—P. H. Geleerd, Acting Canadian Trade Commissioner, Zuidblaak, 26, Rotterdam. Cable address, Watermill.
RUSSIA—C. F. Just, Canadian Government Commercial Agent, Alexandrinskaja, Ploshch 9, Petrograd. L. D. Wiggess, Canadian Government Commercial Agent, Bukhgozla Ulitza No. 4, Omsk, Siberia.
NEWFOUNDLAND—W. B. Nicholson, Bank of Montreal Building, Water Street, St. John's. Cable address, Canadian.
NEW ZEALAND—W. A. Beddoe, Union Buildings, Customs Street, Auckland. Cable address, Canadian.
SOUTH AFRICA—W. J. Egan, Norwich Union Buildings, Cape Town. Cable address, Cantracom.
UNITED KINGDOM—Harrison Watson, Sub-division E.C., 2, 73 Basinghall Street, London, E.C., England. Cable address, Sleighing, London. N. D. Johnston, Sun Building, Clare Street, Bristol. Cable address, Canadian. J. E. Ray, Central House, Birmingham. Cable address, Canadian. J. Forsyth Smith, 31 North John Street, Liverpool. Cable address, Cantracom. F. A. C. Bickerdike, 4 St. Ann's Square, Manchester. Cable address, Cantracom. J. Forsyth Smith, Acting Canadian Trade Commissioner, 87 Union Street, Glasgow, Scotland. Cable address, Cantracom.

CANADIAN COMMERCIAL AGENTS

AUSTRALIA—B. Millin, Royal Exchange Building, Sydney, N.S.W.
BRITISH WEST INDIES—Edgar Tripp, Port of Spain, Trinidad. Cable address, Canadian. R. H. Curry, Nassau, Bahamas.
NORWAY AND DENMARK—C. E. Sontum Grubbeqd No. 4, Christiania, Norway. Cable address, Sontums.
SPAIN—J. F. Roberts, Care British Consulate General, Barcelona.

CANADIAN HIGH COMMISSIONER'S OFFICE

UNITED KINGDOM—W. L. Griffith, Secretary, 17 Victoria Street, London, S.W., England. Cable address, Dominion, London.

which the design of improved apparatus is based and the provision of manufacturing equipment and organization for turning it out, must largely be paid for before the market for it can be developed. It is only by the prompt enlightenment of the prospective consumer—in other words, by educational advertising regarding the applications and advantages of the new article—that the loss of time and the waste which always intervene between the perfection of a device or process and its general use can be reduced.

The introduction of new things is a speculative venture which bars the timid—but for that very reason is highly profitable. Patents more or less effectively insure to the originator a safety zone, protecting him from competition for a limited period that he may have the opportunity to recover his great initial outlay. Advertising, however, is equally useful, since it can shorten the period of loss, conserving for profit-making a greater portion of the several years' monopoly conferred by the patent, and increasing the volume of profit. Advertising itself exerts an accelerating influence on technical development, for before advertising one should have something worth advertising. Much of the strategy in the competitive selling of engineering appliances consists in originating better methods or designs, or new and improved products.

A good example of the necessity of appreciating research on the part of the directors of industrial enterprises is supplied by the editor of *Engineering*, who relates that the firm of Simpson, Maule & Nicholson, in their day, leading manufacturing chemists in England, became millionaires largely through the fact that Nicholson was a very able chemist. When he retired, the firm ceased to develop. His successors employed several able chemists, but these had no control over the business policy and the end was disaster. At one time their leading chemist was the late Prof. Meldola. When he invented his blue, however, the firm refused to take it up, and he accordingly published an account of his discovery with the result that it founded the fortune of a leading German firm. The successor of Meldola was Prof. Green, who invented primulin, a dye of an entirely new type. This the firm refused to patent, and within a few weeks it was in consequence made in Germany, the whole advantage being lost to England.

Engineering products are purchased almost solely for their utilitarian value. Their usefulness can be weighed, measured or computed in some way, and they are usually purchased with much deliberation, for the reasoning faculties of the people who buy them have been emphasized by technical and business training.

The world is run largely on ideas; and the dissemination of ideas is the business of the advertising engineer.

INDUSTRIAL ^A_N^D CONSTRUCTION NEWS

Establishment or Enlargement of Factories, Mills, Power Plants, Etc.; Construction of Railways, Bridges, Etc.; Municipal Undertakings; Mining News

ENGINEERING

Windsor, Ont.—Dodge Brothers, of Detroit, Mich., are making preparations for establishing a plant at Windsor, Ont., at a cost of \$100,000.

London, Ont.—The Spramotor Co. proposes to establish a foundry and machine shop at St. Thomas, Ont., to cost \$100,000. W. H. Heard is manager.

Montreal, Que.—The Riordon Pulp & Paper Co., contemplate developing water powers at Hawkesbury and Merripton, Ont., aggregating 30,000 h.p.

Bay Shore, N.S.—The C. P. R. will build an addition to its roundhouse at Bay Shore, and will also construct a 40,000-gallon water tank. E. N. Bender, Montreal, is purchasing agent.

Fergus, Ont.—Beatty Brothers are receiving bids for the erection, at London, Ont., of a brick and steel foundry, 140 x 160 ft., to cost \$50,000, and a cupola, two storeys, 48 x 48 ft. Mr. Deacon is manager.

Niagara Falls, Ont.—Actual work has been started on the Chippewa-Queenston Power Canal. The construction of a double-track railway to carry material will soon begin now, and then by the fall excavation operations will commence in earnest.

Montreal, Que.—A company has been formed here to manufacture air craft at Laval de Montreal, north of the city. The company are negotiating for the Canadian rights of a new type of aeroplane and have manufacturing rights for a new type of engine.

Quebec, Que.—The Quebec Munitions Co., has secured premises on Dalhousie street in which to commence the manufacture of munitions, Ross sporting rifles and other articles that the company will have authority and facilities for manufacturing very shortly.

Walkerville, Ont.—The Chalmers Motor Co., will rebuild their factory which was recently destroyed by fire. Arrangements are being made by Harry S. Lee, general manager of the company to take over another manufacturing plant in Windsor of Walkerville and get into operation immediately. In the meantime the orders of the Canadian plant will be filled in the Detroit factory.

Waterloo, Que.—The Southern Canada Power Co. has been granted a ten-year exclusive franchise in the town of Waterloo, and street lighting contracts for the same period. The company has also taken over the Richmond light and power to the towns of Richmond, Melbourne, etc., and has also taken over the Cowansville Electric Co., supplying light and power to the towns of Cowansville and Sweetsburg.

Cobalt, Ont.—The McKinley-Darragh have commenced the erection of a new building to house a second flotation plant. The new mill will have a capacity of 200 tons per day, and the re-grinding will be accomplished by a 4 x 8 Marathon mill, the first of its kind to be installed in the Cobalt camp. After re-grinding the sands will be treated in the new Callow oil flotation plant. This new innovation will bring the flotation capacity of the McKinley-Darragh up to approximately 400 tons per day.

GENERAL

Listowel, Ont.—The Perfect Knit Mill Co., contemplate building a factory here to cost \$25,000.

Gladstone, Man.—The plant of the Echo Milling Co., was destroyed by fire on April 1., Loss \$115,000.

Montreal, Que.—The Clark Canning Co., will build an extension to their canning factory at Harrow, Ont.

Chatham, Ont.—C. & T. Hadley are the general contractors for the new factory which will be erected here for Libby McNeil & Libby of Chicago.

MUNICIPAL

Sherbrooke, Que.—The City Council are in the market for a portable air compressor.

Prince Rupert, B.C.—The City Council are considering the question of installing a cold storage plant to aid the fishing industry.

Sudbury, Ont.—The Town Council propose to spend \$46,000 for a stand pipe and auxiliary water main, and \$2,500 for alterations to the lake sewer pumping station.

Regina, Sask.—The City Council is receiving prices for one electric pump, capacity 3,000,000 gallons, and motor. Full particulars may be obtained from J. R. Ellis, city engineer.

Redcliffe, Alta.—The Town Council propose to lay about one mile of 10-in. steel or cast iron pipe, and instal extra pumping plant. Engineer, J. E. Askwith.

Hillsdale, Ont.—It is proposed to instal an electric lighting plant here. The equipment will consist of a gasoline engine and generator. Particulars from T. D. Robinson, township clerk, Moonstone, Ont.

Montreal, Que.—Controller Ross and Dr. Goucher of the City Health Department, will look into a project laid before the Board of Control by Henry F. Cook. Mr. Cook asks for permission to build an abattoir on Itherville street and to deal with all the city's garbage at a

rendering plant outside the city, if the Board will give him six months notice. give him the bodies of all dead animals and pay the costs of conveying them and the garbage to the rendering plant.

ELECTRICAL

Aylmer, Ont.—At a meeting of the Town Council on April 2, a bylaw to borrow \$29,000 for Hydro power by the issue of debentures was passed, \$22,000 being the amount to be set apart for the remodelling of the electrical distribution system and \$7,000 for the installation of an electrically-driven pump, a gasoline pump or an electrically-driven fire pump. A by-law will be submitted to the ratepayers on April 30.

TENDERS

Montreal, Que.—New tenders are being called for road flushing and sweeping machinery.

Drummondville, Que.—Tenders will be received until April 20 for drilling wells and supplying pumping equipment.

Yorkton, Sask.—Tenders will be received until April 30 for one 350-400 b.h.p., combined Diesel electric unit. Specifications may be obtained from F. J. Pilkington, Town Clerk.

Montreal South, Que.—Tenders will be called sometime in April, for a 30-h.p. motor-driven turbine pump and a 150-h.p. gasoline engine-driven turbine pump for fire purposes, etc. F. Drinkwater, St. Lambert, Que., is the engineer.

Edmonton, Alta.—Tenders will be received up to May 1st next, for the supply of automobile markers for the Province of Alberta, during the year 1918. Specifications may be obtained on application to the Deputy Provincial Secretary, Edmonton, Alta.

New Toronto, Ont.—Tenders will be received up to April 13, for gasoline engine and centrifugal pump, Venturi meter and a quantity of flanged pipe for pump house. Plans and specifications may be seen at the offices of the consulting engineers, James, Loudon & Hertzberg, Ltd., 36 Toronto St., Toronto.

Toronto, Ont.—Tenders will be received by Frank Barker, Engineer for the Township of York, up to April 14, for the supply and delivery of 24-inch stop valves and hydrants. Plans and specifications may be seen, and all necessary information obtained, at the office of the engineer, 57 Adelaide Street, East, Toronto.

Winnipeg, Man.—Tenders, addressed to the Chairman, Board of Control, will be received up to April 16, for the supply of labor and materials required in the erection of a 150 foot brick or con-

crete chimney for the Elmwood Incinerator. Plans, specification and form of tender may be obtained at the office of the City Engineer, 223 James Avenue.

Hamilton, Ont.—Tenders will be received up to Wednesday, April 18, for supplying the City Corporation with 400 feet of $\frac{3}{4}$ -inch chemical fire engine hose and with 1000 feet of $2\frac{1}{2}$ -inch cotton rubber-lined fire engine hose, according to specifications prepared by the Chief of the Fire Department, copies of which may be had on application at his office.

Winnipeg, Man.—Tenders addressed to the Commissioners of the Greater Winnipeg Water District will be received up to April 16, for the supply of miscellaneous bronze castings, brass piping, etc., which enter into the construction of a Venturi meter. Specifications and form of tender may be obtained at the offices of the district, 501 Tribune Building, Winnipeg.

Winnipeg, Man.—Tenders addressed to R. D. Waugh, Chairman of the Commissioners, Greater Winnipeg Water District, up to April 16, for the supply of approximately 12,000 feet of 48-inch and 1,300 feet of 60-inch cast iron pipes, together with numerous specials and gate valves. Specifications may be obtained upon application to the offices of the District, 501 Tribune Bldg., Winnipeg.

Winnipeg, Man.—Tenders, addressed to the chairman, Greater Winnipeg Water District Commission, at 501 Tribune Building, Winnipeg, will be received up to April 16, for the supply of one second-hand passenger coach, also one second-hand caboose, both standard gauge. Tenderers to supply own specifications. Further particulars on application to undersigned. R. D. Waugh, Chairman of Commissioners.

Ottawa, Ont.—Tenders will be received until April 21, for steam boilers and stokers required for the Central Heating Plant for the Parliament Buildings. All tenders to be based on the supplying and erecting of three water tube boilers, each having a rated capacity of 500 horse power, together with fittings and soot blowers. Each tender shall give separate quotations for supplying and erecting, in connection with boilers, three automatic stokers. One boiler and stoker shall be erected complete within five months after date of awarding contract and the other two shall be erected before January 1st, 1918. Plans, specifications and any other information required can be obtained at the office of the general contractor, P. Lvall & Sons Construction Co., Ltd., Ottawa.

PERSONAL

E. T. Austin has been appointed manager of the Belleville Waterworks Department in succession to J. W. Evans.

Thomas J. Gerry who for over twenty-five years was connected with the Dodge Manufacturing Co., Toronto, as

traveller died at his home in Toronto recently.

George Bury vice-president of the C.P.R. has returned to London from Russia where he has been on an important business trip in the interests of the company.

W. G. Ross, chairman of the Harbor Commissioners of Montreal, went to New York recently to attend an executive meeting of the American Association of Port Authorities. Mr. Ross is president of the Association.

John J. Drummond, of Midland, Ont., died at the home of his brother, George E. Drummond, in Montreal, on Saturday, April 7. Mr. Drummond was long identified with the development of the iron and steel industry in Canada. In association with his brothers, George E. and the late T. J. Drummond, he established iron furnaces at Radnor, Quebec, and opened up large iron properties in the Maritime Provinces. He was president of the Zenith Machine Co., Midland, Ont. The deceased was born in the North of Ireland in 1856 and came to Canada at an early age.

BUILDING

Hamilton, Ont.—Plans are being prepared for an office building for the Canadian Westinghouse Co., on Sanford Ave.

Stratford, Ont.—Tenders for the additions for Brunswick and Shakespeare schools have been opened, and will be finally dealt with at a special meeting of the board to be held shortly. The committee has approved of a \$7,722.50 tender for Brunswick school, but has taken no action on the Shakespeare tender. Both are higher than estimates.

TRADE GOSSIP

The Chevrolet Motor Co. of Canada has increased its capital stock to \$1,500,000.

The Dominion Steel Foundry Co. and its subsidiary, the Hamilton Steel Wheel Co., are to be amalgamated and incorporated under the name of the Dominion Foundries & Steel Ltd. Both plants are located at Hamilton, Ont.

The Hall Engineering Works, with which is associated the Montreal Dry Dock Co., have started work on a new 50 by 150 feet plate and boiler shop at the plant of the latter. In addition to equipment already on hand, more new machinery will be required.

Big Demand for Ore Tonnage.—John Bell, general superintendent of the Playfair steamship interests at Fort William, Ont., after an extended trip to Buffalo, Cleveland and Chicago, reports there is a very heavy demand for tonnage for ore.

Copper Mine Reopened.—The copper mine at Red Head, Charlotte county, N.B., formerly operated by James McLean of Letete, has been reopened by a New York syndicate. A quantity of ore has been taken out and shipped to the United States for testing.

Ontario Hydro Surplus.—According to the report of the Hydro-Electric Power Commission for the year ending October 31, 1916, there was a surplus on the Niagara system of \$351,833, applicable to sinking fund and depreciation reserve account, the receipts being \$2,038,792 and the disbursements \$1,686,958. The total operating capital is \$9,522,995. On the Severn system there was a surplus of \$40,256; the deficit on operation of the Eugenia system was \$12,120, while the Wasdells system showed a surplus of \$4,569.

Making Valuation of Ross Rifle Plant. A valuation of the machinery and contents of the Ross Rifle Factory at Quebec, which the Dominion Government is expropriating, is being made by experts supplied by the Canadian Appraisal Co. and an accountant representing the Department of Militia and Defence. It is said the task will occupy the valuers for about two months. When it is completed, an offer will be made, it is understood, to the Ross Rifle Company on behalf of the Government. If that offer is not accepted recourse will be had to the Exchequer which will fix the price to be paid for the plant.

Opening of Navigation Forecast.—Predictions reaching the Marine Department, Ottawa are to the effect that navigation will not be open on Lake Superior until April 25. Lake Huron and Georgian Bay will be navigable somewhere about April 15. The St. Clair River, Lake St. Clair and Detroit River and the Western portion of Lake Erie are already clear of ice. At the eastern end of Lake Erie, however, there is still considerable ice, which makes it probable that navigation there will not begin until April 15 or 20. Similarly the western end of Lake Ontario is free of ice and the eastern end is not. Hence the prospect is that navigation there will not be open until April 15 or 20.

The Prest-O-Lite Co., Inc., manufacturers of oxy-acetylene welding and cutting outfits, storage batteries, etc., have just let a contract for the erection of a four storey building in Toronto which will be used for the manufacture of electric storage batteries and accumulators, etc., with 35,000 sq. ft. of floor space. Construction will be commenced at once of an acetylene gas plant at Shawinigan Falls, Que., while facilities at Merriton, Ont., will be considerably enlarged. Warehouses and show rooms will be opened in Montreal for both storage batteries and gas appliances. R. H. Combs Canadian general manager was, until recently, vice-president of the Society of Automobile Engineers.

British Embargo Lists Changes.—The British Government has prohibited the exportation of the following articles to all destinations. Anchors and chain cables, binnacles, leather boots and shoes with soles or uppers, lead compounds and mixtures containing them; ships' compasses and component parts; leather; lead, lead alloys and manufacturers of lead or alloys; nautical instruments;

The LeBlond ^{Tool and Cutter} Grinder

Try this Grinder—

It has been specially designed for the tool room and is perfectly at home in every department of cutting where Convenience, Precision and Production are essential.

It has numerous features which you need—Catalog—free on request—will tell you all about them.

Shipment from TORONTO STOCK IMMEDIATELY.

THE A. R. WILLIAMS MACHINERY CO., Ltd.

64 Front St. West - TORONTO, ONT.
ST. JOHN, N.B. WINNIPEG VANCOUVER

"If It's Machinery, Write Williams."

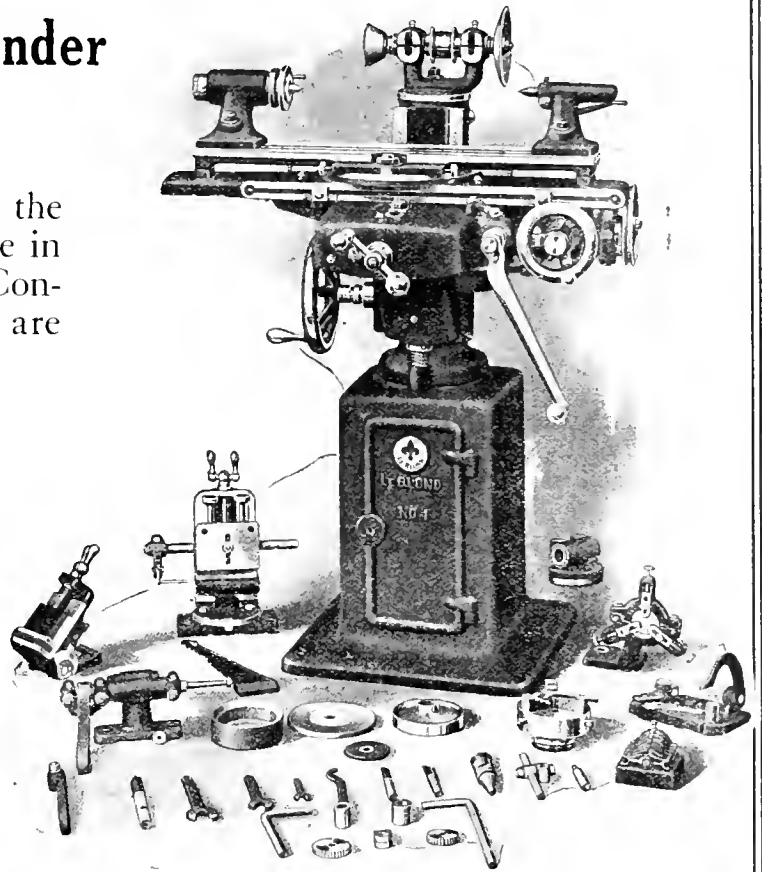

The limits on this job are very close, but a Geometric Self-Opening Die Head finishes the threads so that they pass rigid inspection.

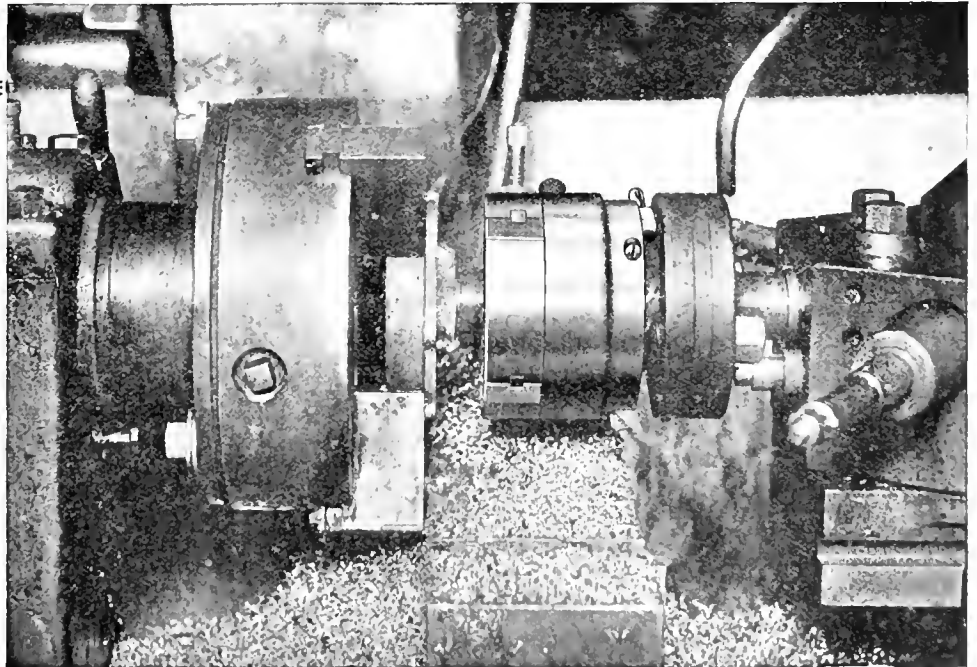

The part is a manganese bronze pump body, made by the Superior Machine & Engineering Co., on a Warner & Swasey Screw Machine.

Have you a Geometric on your Screw Machine or Turret Lathe? Send us your specifications and get our quotation.

THE GEOMETRIC TOOL CO., New Haven, Conn., U.S.A.

Williams & Wilson, Ltd., Montreal. Canadian Agents: The A. R. Williams Machinery Co., Ltd., Toronto, Winnipeg, St. John, N.B.

If any advertisement interests you, tear it out now and place with letters to be answered.

PATENT ATTORNEYS

BABCOCK & SONS

ESTAB. 1877

PATENTS—TRADE MARK—DESIGNS
 IN ALL COUNTRIES

 Book "Patent Protection"—free. Master
 of Patent Laws, Formerly Patent Office
 Examiner.

 99 St. James St., - Montreal, Que.
 Branches: Ottawa, Washington.

RESEARCH BUREAU

 REPORTS BY EXPERTS ON SCIENTIFIC, TECHNICAL
 AND INDUSTRIAL DEVELOPMENT.

SPECIAL RESEARCHES ARRANGED.

PATENTS, TRADE MARKS, ETC.

 HANBURY A. BUDDEN CABLE ADDRESS
 712 DRUMMOND BLDG., MONTREAL "BREVET"

PATENTS

Fetherstonhaugh & Co.
 Patent Solicitors, Head Office,
 Royal Bank Bldg., Toronto.
 Ottawa Office, 5 Elgin St.
 Send for our Plain Practical
 Pointers. Copy of National
 Progress, in which our patents
 are advertised, mailed free.

PATENTS PROMPTLY SECURED

 In all countries. Ask for our Investor's
 Adviser, which will be sent free.

MARION & MARION, 364 University St.

 Merchants Bank Building, corner
 St. Catherine St., MONTREAL. Phone Up. 6474
 and Washington, D.C., U.S.A.

SPECIAL MACHINERY

 GAUGES, FIXTURES, DIES
 AND
 PRECISION TOOLS

 WE HAVE THE
 MOST MODERN
 EQUIPMENT
 TO HANDLE
 ANY CLASS OF WORK

 CANADIAN DISTRIBUTORS FOR THE
**ALBANY PATENT ROTARY
 PUMP**
Albany Pump Co.

 16 Pearl St., TORONTO, Canada
 Phone Ad. 2511 A. W. Bennet, Manager

bootmaking machine needles; rattans; ship engines and their component parts, including Diesel and other internal combustion engines for marine propulsion; iron and steel castings and forgings for ships' hulls and machinery; machinery for steamships and component parts; sectional materials for shipbuilding; ships' auxiliary machinery; ships' telegraphs and component parts; steering gear and component parts; tanning extracts and substances; winches, windlasses.

Big Freighter Launched.—Last Thursday at 1.30 p.m., in the presence of a large number of spectators, the bulk freighter Westmount was successfully launched at the yard of the Collingwood Shipbuilding Co., Collingwood, Ont. The christening ceremony was gracefully performed by Mrs. L. L. Henderson, wife of the president of the Montreal Transportation Co., for which the new steamer is built. The Westmount is one of the largest boats on inland waters. Her dimensions are: Length 550 feet; breadth, 58 feet, and depth 31 feet, with a carrying capacity of 11,000 tons. Her engines are capable of developing 2,400 horse-power, and will drive the steamer thirteen miles per hour loaded. The steamer is modern in every way, and embodies many new features to facilitate loading and unloading operations. There are sixteen hatches, with 24-foot centres, and the large holds are divided into 24 compartments. The Westmount will go into commission immediately upon the opening of navigation.

MARINE

Sault Ste. Marie, Ont.—Navigation will open about April 20 if reports reaching the Soo are authentic. Ice-crushers will be used to force an opening in Mud Lake, St. Mary's River and Whitefish Bay. Unless this is done ice will hold up lake traffic until May 1.

Must Install Water Purifiers on Lake Boats.—Before the opening of navigation vessel owners of the Great Lakes must spend approximately \$300,000 for the installation of new culinary and drinking water purifiers on all boats engaged in interstate traffic. The order applies to all vessels belonging to Canadian steamship companies plying on the Great Lakes. The order requiring installation of pure water systems was issued some time ago by Dr. J. O. Cobb, Chicago, surgeon of the sanitary district comprising the Great Lakes. The water must be treated by an approved method, and that the piping system on all vessels must be so arranged that no connection can be made between the drinking water system and any other water system.

WOODWORKING

Montreal, Que.—The Montreal Box Board Co., will build an extension to their factory.

Quebec, Que.—The box factory of the Canadian Butter Box Co., at D'Israeli, Que., near Sherbrooke, was burned to the ground on April 4.

CONTRACTS

Port Arthur.—J. F. Hewitson has been awarded the contract for the construction of buildings for the Port Arthur Pulp and Paper Co.'s plant here to the extent of \$350,000.

INCORPORATIONS

Lion Locks, Ltd., has been incorporated at Ottawa, with a capital of \$50,000, to manufacture builders' hardware, locks and locking devices of all kinds. The head office is at Toronto and the incorporators are: Aubrey T. Maher, John B. O'Brien and Thomas S. H. Gales, all of Toronto.

J. R. Cameron, Ltd., has been incorporated at Ottawa, with a capital of \$50,000, to take over the business carried on by J. R. Cameron, stove and furnace manufacturer, of Ottawa. The incorporators are: Joseph R. Cameron, R. Edward Byrne, and John S. Nicholson, all of Ottawa.

Huot Rifle Automatic Attachment Co., has been incorporated at Ottawa with a capital of \$500,000 to manufacture rifles and rifle parts. The head office of the company is at Montreal and the incorporators are Joseph A. Huot, S. Edmond Desmarais and Joseph A. Belair all of Richmond, Que.

The Omega Machinery Co., has been incorporated at Ottawa with a capital of \$45,000 to manufacture water towers, wind-mills, pumps and all kinds of machinery at St. Hyacinthe, Que. The incorporators are Ovide Brouillard, Etienne H. Solis of Montreal and Emile Ponton of St. Hyacinthe.

The Collier Oil Co. has been incorporated at Ottawa, with a capital of \$2,000,000, to acquire oil lands and to construct and operate refineries at Calgary, Alta. The head office is at Toronto, and the incorporators are: Henry P. O. Savary, Lloyd H. Fenerty, and Henry A. Chadwick, all of Calgary.

P-K Worsted Spinning Mills Ltd., has been incorporated at Toronto with a capital of \$50,000 to build and operate spinning mills and dye houses at Listowel, Ont., Provisional directors are Frank J. Barber of Georgetown, Ont., and Max Becker and John H. Bender of Listowel, Ont.

The Paper & Hardware Products, Ltd., has been incorporated at Ottawa, with a capital of \$49,000, to manufacture paper, felt, straw board and pulp products of all kinds. The head office is at Montreal, and the incorporators are: W. A. Lyons, Henri Larin and Patrick A. Donnelly, all of Montreal.

CATALOGUES

Electric Drills.—Circular Y is being distributed to the trade by the Independent Pneumatic Tool Co., Chicago, Ill., to feature the "Thor" universal electric drills. The circular illustrates a number of different types and con-

tains specifications covering the various sizes.

The Watters' Bucket for use in foundries is described in catalogue 126 being distributed by the Whiting Foundry Equipment Co., Harvey Ill. The advantages of the Watters' bucket and its construction and operation are dealt with while several views of installations show the scope of service of the bucket.

Taylor Power Dump.—Catalogue issued by the American Engineering Co., Philadelphia, Pa., describing the Taylor power dump for use in conjunction with the Taylor mechanical stoker. The construction of this power dump and results accomplished by it are described while the method of operation is graphically explained by means of a number of illustrations.

The Standard Mfg. Co., Bridgeport, Conn., have issued a series of bulletins 202, 203, 212, 217, 219, 220, 221, 232, 233, 234, 235, 236, 237 bound in an attractive loose leaf folder illustrating and describing an interesting line of machine tools including gear cutting, automatic milling, drilling and riveting machines, etc., excellent half tones show the general arrangement of each type of machine while a specification is included together with descriptive matter covering the principal features.

Standard-Unit Construction for Steel Framed Structures.—F. Braby & Co., Glasgow, Scotland, have recently issued an interesting catalogue bearing the above title and illustrating the Reid patent unit system for the construction of steel buildings and structures of every description. The catalogue features a new system of quick fabrication and erection of steel structures. The catalogue contains a full description of the system and also a large number of diagrams showing various designs of steel work for factories, hangers and aeroplane sheds, etc. The concluding pages contain considerable useful technical data covering the properties and safe strengths, etc., of the standard units and bars, abridged list of spans and heights of building obtainable, and particulars of Braby's corrugated sheeting.

BOOK REVIEW

Canadian Woods for Structural Timbers.—The Department of the Interior, Forestry Branch, Ottawa, have published Bulletin No. 59, bearing the above title. The idea in publishing this bulletin was to offset an erroneous belief held by many Canadians that imported lumber is superior to the Canadian product. The Forest Products Laboratories of Canada, under the Forestry Branch of the Department of the Interior, have been investigating this question, and have found that some of our Canadian timbers are superior to those imported and just as cheap, if not cheaper. The results of this investigation are set forth in this bulletin, which also contains a number of interesting half-tones showing Canadian lumber being utilized for

**TRY HAMILTON
BABBITTS**
We Make Nothing Else
GEO. E. JOBBORN, Hamilton, Ont.

**MacKinnon, Holmes
& Company, Limited**
Design, manufacture and erect all classes of Steel Work.
Specialties:-
Bridges
Oil and Water Tanks
Penstocks
Coal and Coke Bins
Smoke Flues & Stacks.
Prompt deliveries assured.
Designs and Estimates from Head Office at
SHERBROOKE, QUE.

**METAL
STAMPINGS**

We are manufacturers of stamped parts for other manufacturers.

We do any kind of sheet metal stamping that you require. Our improved presses and plating plant enable us to produce the finest quality of work in a surprisingly short time.

We can finish steel stamping in Nickel, Brass or Copper.

Send us a sample order.

W. H. BANFIELD & SONS
372 Pape Avenue, Toronto, Can.

**"HAWK" D
CHROME
VANADIUM
STEEL**



Will Give You Exceptional
**Shell Forging
Production**

WITHOUT AN EQUAL FOR BOTH FIRST AND SECOND OPERATION PUNCHES.

Comes to you heat-treated and ready for use. It does not stick to the work. There are many cases where each punch has turned out over 2,000 shells. It means more shells, per machine per day.

STEEL OF EVERY DESCRIPTION.

**Hawkrige Brothers
Company**
303 Congress St., BOSTON, MASS.
U. S. A.

THE IRON WORKS LIMITED
Successors to

Owen Sound Iron Works
Owen Sound, Ont.
Engineers
Boiler-makers
Founders
Machinists

Tank Work
Smoke Stacks,
Grey Iron and
Brass Castings,
Social Machinery
Made to Order

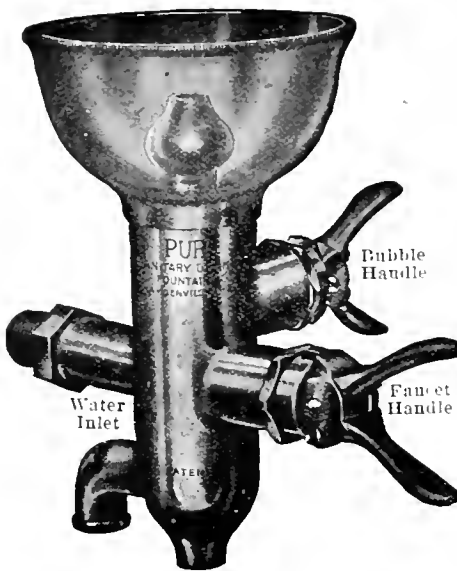

Saving or Wasting?

The manner in which you handle the drinking water problem in your plant may seem to be a small matter to you—but investigate. The results will be surprising.

The old-time faucet is costly. Running hour after hour, day after day, its ceaseless flow is costing you money, yet without any better service.

Puro Saves 35%

A Puro Sanitary Drinking Fountain will cut that water bill 35%. We can prove that it has done that for others.

It will give every employee a safer, saner draught of bubbling water free from the contamination of the common drinking cup.

In a word, it is the only sanitary Drinking Fountain that is really safe, sanitary, simple, automatic in control, and easy to attach.

"PURO - FY"

(MADE IN CANADA)

YOUR WATER SUPPLY

Puro Sanitary Drinking Fountain Company
147 University Ave., Toronto, Canada

a variety of structural purposes. Lumbermen, builders, manufacturers, or others interested who have not yet received a copy may obtain one free on application to the Director of Forestry, Ottawa.

HIGHER COAL COMING.

The *Coal Trade Journal* says that the anthracite situation is growing very strenuous. It is said that the production of anthracite this year will hardly equal the consumption, and a shortage of cars is making it difficult to get coal into the New York market. The labor supply limits the production of coal, and with high wages in all fields labor is taking matters easily. Within the week there has been a considerable advance in the price of anthracite, and the retailer who is not forearmed with contracts to insure him a regular supply to take care of his customers, faces a hard winter. Some of the independent producers, finding an extra demand upon them, have been putting the price up day by day until premiums amounting to \$1 a ton above the supposedly regular schedule have been paid. This is taken to mean that there must be an advance in the retail price, for the margin allowed the retailer is not sufficient to permit him to take up the advance in the wholesale price, even though premium coal is but one-fourth of his tonnage.

TUNGSTEN IN PORTUGAL

SOME very rich deposits of tungsten occur, it is said, in Portugal in the form of wolframite, accompanied by scheelite, and also, frequently, by cassiterite (binoxide of tin). The three principal deposits are the property of independent companies, the first, a French concern, exporting its whole output to France; the second, an English company, exporting to England; and the third, which is operated exclusively by Portuguese capital. The daily output of the first two averages about one ton of wolframite each, containing 60% of tungsten trioxide; the output of the other concern is somewhat less. In addition, there are numerous smaller deposits, but the output of these is not known. In 1914 the exports of tungsten ore from Portugal amounted to 1,700 tons. No figures, however, are available as to the quantity produced. At present the exportation is made under the intervention of France and Great Britain, which countries absorb the greater part of the total shipments. A small quantity is exported to the United States.

MUNITIONS WORK IN SIGHT

FIRMS engaged in the manufacture of munitions in Canada will, on the basis of present orders, be kept busy up to June 30, 1917. Orders placed with some manufacturers expire on December 31, and with others on March 31. When these dates arrive, the performance

made in delivery will be an important factor in deciding as to the extent of renewal orders. The Imperial Munitions Board states that all necessary raw materials to maintain the deliveries required are contracted for well ahead, and particular mention is made of the very favorable position in respect to steel supply. No uneasiness is caused by the reported shortage in the States, because of the purchases of steel made by the board last spring and summer.

The policy adopted some time ago, whereby Canadian manufacturers would supply fuses, primers, brass discs, cart-ridge cases and the many smaller components, is now well established, and supplies of this nature which came from the States in large quantities in the past, will to a very great extent be available in Canada. Canadian manufacturers are bending their best energies to enable the board to carry out its programme.

TECHNICAL MEN GIVE AID

THE Joint Committee of Technical Organizations, under the chairmanship of Alfred Burton, met in the Mining Building of the Toronto University group on March 30, to discuss and adopt the first annual report of the organization and to hear addresses by E. P. Mathewson, of Toronto; R. A. Ross, of Montreal; John Murphy, of Ottawa, and Captain A. J. Matheson, of Toronto. J. Murray Clark and W. A. Carlyle also spoke.

The chairman in opening referred briefly to the aims and objects of the committee which was formed last December, and is composed of one representative from each of the various technical and scientific institutions, societies and associations of Ontario. "The immediate aim," said Mr. Burton, "shall be to evolve a plan whereby such of our members as are unable to go to the front may be used for war purposes at home in such a manner as their special technical training may make them most valuable." He then proceeded to outline some of the work already accomplished by the committee, which, within three months, has already made many practical contributions towards the national efficiency for the prosecution of the war.

MISCELLANEOUS

Steel and Malleable Iron Castings.—The choice between steel and malleable iron castings is dictated by their respective properties, partly by price, and partly by the limitations of the processes by which malleable iron is made. As pointed out in a paper read before the International Engineering Congress, steel is, in its nature, a more homogeneous metal, and, therefore, tougher and stronger than malleable iron. Moreover, castings of malleable iron are

"Barnes-Made" SPRINGS

are unusual in service and wear

They are the result of sixty years' experience, unsurpassed equipment and highly skilled workmanship.

A trial will convince you that "Barnes-Made" Springs are the best buy.

Established 1857

THE WALLACE BARNES COMPANY
218 South St., Bristol, Ct., U.S.A.

Makers of "Barnes-made" Products
Springs, Screw Machine Products, Cold Rolled Steel and Wire

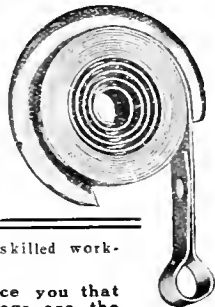

somewhat prone to actual porosity or sponginess at the centre, especially in certain portions of irregular castings, so that for this reason also a steel casting is stronger and more reliable. Finally malleable iron can be made only into castings of quite light sections, whereas there is almost no limit to the size and weight of steel castings that can be produced. For uses where only a fair amount of strength and toughness is necessary, the castings being therefore of light section, it often pays to have them malleable, because they are cheaper than steel.

Friction Clutch Ring Tests.—In a recent issue of Alfred Herbert's Monthly Review an experiment is described which was made for the purpose of testing various designs of friction rings for use in the friction clutches of lathes. The ring being tested was held by hooks and opened by lifting up by a crane or lifting blocks, the stress being measured by a portable weighing apparatus. The expansion of the ring under different loads was measured by dividers set to centre dots in the same way as the expansion of a tensile test specimen is measured. By this means it was possible to obtain for each ring a record of the different expansions under various loads, which could be plotted in the form of a stress-strain diagram, and records were also obtained of the final breaking load and of the maximum expansion before breaking. By testing a number of rings of different material and of different design and proportions under these conditions considerable improvement has been made in the design of the friction clutches.

Concerning Twist Drills.—It seems incredible, says a writer in Alfred Herbert's Monthly Review, that no twist drill maker sends his product out correctly ground ready for use. Every drill maker claims some good point or other for his tools. Many or all of them have spent thousands of pounds experimenting with various shapes of flutes, angles of spiral, thickness of web, and so forth; further, thousands of pounds have been laid out on plant, tools and equipment, yet the one part of a drill that counts, perhaps, more than any other—the cutting edge—receives little or no attention. Why this should be probably no one can tell. It seems to the writer that the first drill maker who advertises the fact that his drills are ground correctly, ready for immediate use, will reap inestimable advantages in the way of largely increased sales. We believe that, if the writer is not misinformed, he has greatly overstated his case.—Ed.

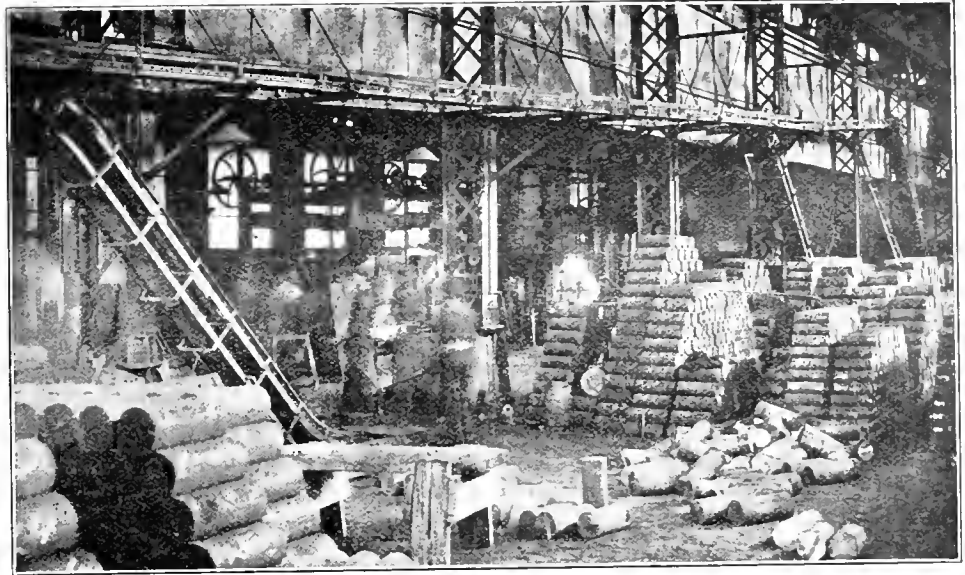

Steel Shell Forgings or Billets of any size or weight will move any distance or about curves upon our specially constructed Gravity Carriers and Incline or Horizontal power devices. No labor required.

Canadian Mathews Gravity Carrier Co., Toronto, Ont.

MORTON MANUFACTURING CO.
 PORTABLE PLANERS
 DRAW CUT SHAPERS
 SPECIAL DRAW CUT R R SHAPERS
 FINISHED MACHINE KEYS
 STATIONARY & PORTABLE KEY WAY CUTTERS
 SPECIAL LOCOMOTIVE CYLINDER PLANERS
 OFFICE AND WORKS: MUSKEGON HEIGHTS, U.S.A.

OVENS
 Enameling and Varnishing Ovens heated by Gas, Electricity, Steam or Coal.
 Write for Booklet.
Brantford Oven & Rack Co., Ltd.
 Brantford, Canada.

Over the Page

You'll find a number of small items, some of which will most certainly interest you. Every week there are opportunities galore offered there.

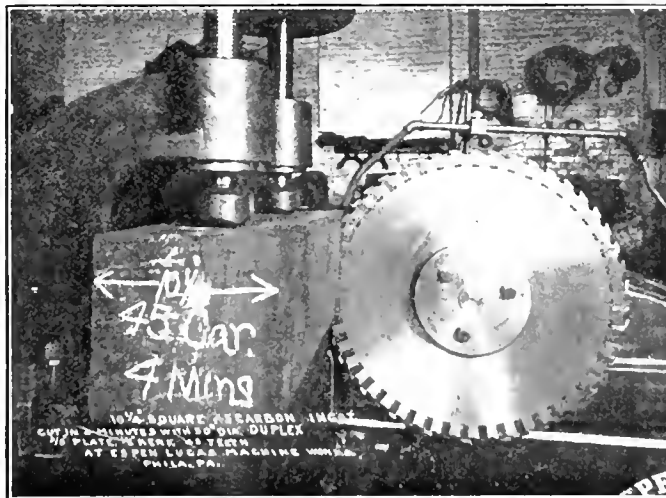

Circular Metal Cutting Saw Blades for Any Type of Machine

Let us demonstrate what a saving can be made by installing a **HUNTER "DUPLEX" Inserted Tooth Blade**

Write for information
HUNTER SAW & MACHINE CO., Pittsburgh, Pa., U.S.A.

Classified Advertising Section

Rates (payable in advance): Two cents per word first insertion; one cent per word subsequent insertions. Count five words when box number is required. Each figure counts as one word. Minimum order \$1.00. Display rates on application.

WANTED

WANTED — LATHE ABOUT 48" SWING or larger, also boring mill up to 60". Must be in good order and reasonable price. Apply Box 288, Canadian Machinery. c16m

FOR SALE

FOR SALE — AT A BARGAIN — 1-1 1/4" style D geometric die head, with extra dies. White Machine Works, Windsor, Ont. c16m

GAP LATHE, 28 x 42 x 16 FT. BED, FOR sale, cheap; also emery wheel stand, power hack saw. Guarantee Motor Co., Hamilton, Ont. c16

FOR IMMEDIATE SALE—THE FOLLOW-ing West Tire Setter Company banding presses: 1—9.2"; 1—6"; 1—3 1/4". All in first-class condition. Each been in use two months. The Elyria Machine Co., Elyria, Ohio. c15m

FOR SALE—ONE 450 H.P. THOMPSON & Williams condensing engine. Will sell cheap. Engine is in first-class repair and will give every satisfaction. Apply J. A. Marven, Limited, Moncton, N.B. tcmf

ONE No. 2 WHITING CUPOLA, 36" SHELL capacity, one to two tons per hour. In perfect condition, used only for two heats. Address Purchasing Agent, Canadian Ingersoll-Rand Co., Ltd., Sherbrooke, Que. ctmf

2 CAN. GEN. 2 H.P., 1,200 R.P.M., 440-VOLT, 3-phase, 60-cycle induction motors, complete with pulley and slide base, \$85.00 each. 1—1 H.P. ditto, \$70.00. 1—Canadian Ingersoll-Rand air compressor, having displacement of 64 cubic feet per minute when running at 250 R.P.M. At 100 lbs. pressure it will require 11 H.P., \$340.00. The Perfection Stove Company, Ltd., Sarnia, Ont. c15m

FOR SALE — TWELVE PRACTICALLY new No. 7-C Racine Heavy Duty High Speed Back Saw Machines. Suitable for all cutting purposes. Immediate delivery. For Price and further information address The Peck Rolling Mills, Limited, Montreal. c14m

ONE LATHE 16" x 4 1/2' back geared. Built by P. P. Silk Machine & Tool Co., Cincinnati, Ohio. One lathe 18" x 3', back geared. Built by the Bradford Mill Co., Cincinnati, Ohio. Four Murchey Collapsible Dies. Capacity 1 1/2" to 2 1/2". Box 272, Canadian Machinery. ctmf

WE OFFER THE FOLLOWING MACHIN-ery and tools at exceptionally low prices: 1—Heavy Duty Rockford Drill, 24", suitable for heavy work, in use only two months. 4—Jones & Lamson Turret Lathes, Bar machines, size 2 x 24; price \$200.00 to \$250.00

each. 2—Jones & Lamson Turret Lathes, Chucking Machines, size 2 x 24; price \$200.00 each. 1—Small Turret Lathe, 1 1/4 hole in spindle, 1 1/4 hole in turret head. 1—Two-spindle Sensitive Drill, \$100.00. 2—Holden-Morgan Thread Millers, slightly used on 4.5 shells. 4—Bertram Internal Thread Millers. 2—No. 9 Hartness Dies, capacity range 1 1/4 to 3" dia. 4—32" Whiton Universal Scroll Heavy Duty Chucks, 3-jaw. 1—10" Skinner Universal Chuck, 3-jaw. 1—10 x 12 3/4 H.P. Robb Horizontal Steam Engine, in first-class condition. Apply Steel Furnishing Company, Limited, New Glasgow, N.S. Cow17

SPECIAL MACHINERY

MANUFACTURERS — WE CAN UNDER-take work to any specification—munition production equipment or otherwise. Write W. H. Sumbling Machinery Co., 7 St. Mary St., Toronto.

O. E. WOODS—HEAVY, LIGHT AND GEN-eral machine work. We are prepared to make to specifications and drawings, special machinery, punches and dies, jigs, fixtures and general tools. Prices reasonable. Prompt attention. Phone Gerrard 960. Address 754 Broadview Ave., Toronto, Ont.

Do you read these pages?

Of course you do. Then isn't it safe to assume that the majority of our readers do? When we get a reply to an ad from a firm like the National Cash Register Company one mail, and another from a machine tool salesman the next, and others from men in all positions, it would appear that these ads. are pretty closely followed.

If you have any proposition likely to interest our readers it will pay you to tell them about it here.

Canadian Machinery

Classified Advertising Section

143 University Ave., Toronto, Ont.

SITUATIONS WANTED

SUPERINTENDENT—PRACTICAL MECH-anical man with 12 years' experience, last two years superintendent of shells, is open for a proposition. Box 289, Canadian Machinery. c16m

SUPERINTENDENT OR WORKS MAN-ager of large metal working plant desires change. Broad gauge man of modern methods and a producer of results. Over 20 years' experience at handling large forces of workmen in manufacture of high quality and interchangeable goods of brass, iron and steel, special tools, dies, machinery, etc. Includes brass works, machine shop, punching and stamping and fine brass work, taking entire control of plant. English-American descent. Box 280, Canadian Machinery. c15m

SITUATIONS VACANT

A GENERAL SALESMAN TO HANDLE our general lines in part of Ontario. Apply Box 290, Canadian Machinery. c16m

YOUNG MAN WITH GENERAL KNOWL-edge, to take charge of our sample floor. Apply Box 291, Canadian Machinery. c16m

WANTED—MACHINERY SALESMAN TO handle Toronto and Western Ontario. Apply, giving experience to Box 285 Canadian Machinery. c14m

MECHANICAL ENGINEER WANTED — first-class opportunity for the right party. Must be energetic, ambitious, sober and have some knowledge of French. Apply Box 286, Canadian Machinery. tcmf

PRODUCTION ENGINEER WANTED TO take charge of cost reduction work in Canadian shop manufacturing air compressors, rock drills and other lines. State age, experience and salary expected. Box 292, Canadian Machinery. c16m

MAN ABOUT 30, WITH ENGINEERING and commercial training, experienced in mine and smelter requirements, including structural and cast steel work. A man with office experience and capable of soliciting business preferable. Box 283, Canadian Machinery. c13m

EXPERIENCED TOOL MAKERS, SCREW machine hands and general mechanics wanted at once for new, well lighted plant (not munitions), situated just outside of Toronto; highest union wages and steady work for good men. Mention this paper. Canada Cycle and Motor Company, Limited, Weston, Ont. c13m

A GOOD SALES ENGINEER TO OPEN office to sell Moline Heat in Canadian territory. Must be a good salesman, having had a general heating and ventilating experience. Must give good references. We have a fine proposition for the right man. Address, Moline Heat, Moline, Ill. ctmf

CANADIAN MACHINERY

AND MANUFACTURING NEWS

A weekly newspaper devoted to the machinery and manufacturing interests.

Vol. XVII.

TORONTO, APRIL 19, 1917

No. 16

EDITORIAL CONTENTS

Tool Holder and Cutting Tool Application Data—I	389-390
Production Methods and Devices	391-394
Special Design Thread Milling Machine....Multiple Drill Heads....Boring An Igniter Hole....V-Block for Keyseating.	
General	394
Detinning Apparatus....Some C.P.R. Facts.	
Worm Gear Design Features and Worm Gear Mounting Detail	395-397
General	397
Shaft Troubles.	
Editorial Correspondence	398-399
Machinists' Instruction Course—XVIII....The Machine Shop Oil Can....Cutting Undersize Threads With Oversize Dies....Protecting Belt Laces From Vermin.... Business Magnanimity.	
Contemporary War Articles	400-401
The German 4.2 CM. Howitzer.	
Observations on Safety Valves for Marine Boilers	402-405
General	405
Heating by Steam at Different Pressures....Advantages of Economizers....Util- izing Exhaust Steam....Reducible Losses in Power Plants.	
Progress in New Equipment	406-407
Fluid Gauge for Measuring Work....Cell Mounting Oil Circuit Breaker....Ship Band Saw....14-inch Tool Room Lathe.	
General	407
Combustion in Hand-Fired Furnaces.	
Editorial	408
Our Shell Industry Ebbing....The Shipbuilding Situation.	
Industrial Notabilities	409
Colonel David Carnegie.	
Selected Market Quotations	410-411
The General Market Condition and Tendency	411-413
Montreal Letter....Toronto Letter.	
The Passing of "Jim Brady"	413-414
Industrial and Construction News (Advtg. Section)	62-66

THE MACLEAN PUBLISHING COMPANY, LIMITED

JOHN BAYNE MACLEAN, Pres. H. T. HUNTER, Vice-pres. H. V. TYRRELL, Gen. Man.

Publishers of Hardware and Metal, The Financial Post, MacLean's Magazine, Farmer's Magazine, Canadian Grocer, Dry Goods Review, Men's Wear Review, Printer and Publisher, Bookseller and Stationer, Canadian Machinery and Manufacturing News, The Power House, The Sanitary Engineer, Canadian Foundryman, Marine Engineering of Canada.

Cable Address: Macpubco, Toronto; Atabek, London, Eng.

ESTABLISHED 1887.

CANADIAN MACHINERY AND MANUFACTURING NEWS

PETER BAIN, M.E., Editor. B. G. NEWTON, Manager.
Associate Editors: A. G. WEBSTER, J. M. WILSON, J. H. RODGERS.

CHIEF OFFICES:

CANADA—Montreal, Southam Building, 128 Bleury Street; Toronto, 143-153 University Ave., Telephone Main 7321; Winnipeg, 22 Royal Bank Building, Telephone Garry 2313.

GREAT BRITAIN—LONDON, The MacLean Company of Great Britain, Limited, 88 Fleet Street, E.C., E. J. Dodd, Director. Telephone Central 12900. Cable Address: Atabek, London, England.

UNITED STATES—New York, R. B. Huestis, 115 Broadway, N.Y., Telephone Rector 8971; Boston, C. L. Morton, Room, 733, Old South Building, Telephone Main 1201. A. H. Byrne, 11015-6-7 Fort Dearborn Bldg., 105 W. Monroe St., Chicago, Telephone Randolph 3234.

SUBSCRIPTION PRICE—Canada, Great Britain, South Africa and the West Indies, \$3.00 a year; United States, \$3.50 a year; other countries, \$4.00 a year; Single Copies, 15 cents. Invariably in advance.

Hendey Millers will take any kind of a miller job

that comes into the modern shop

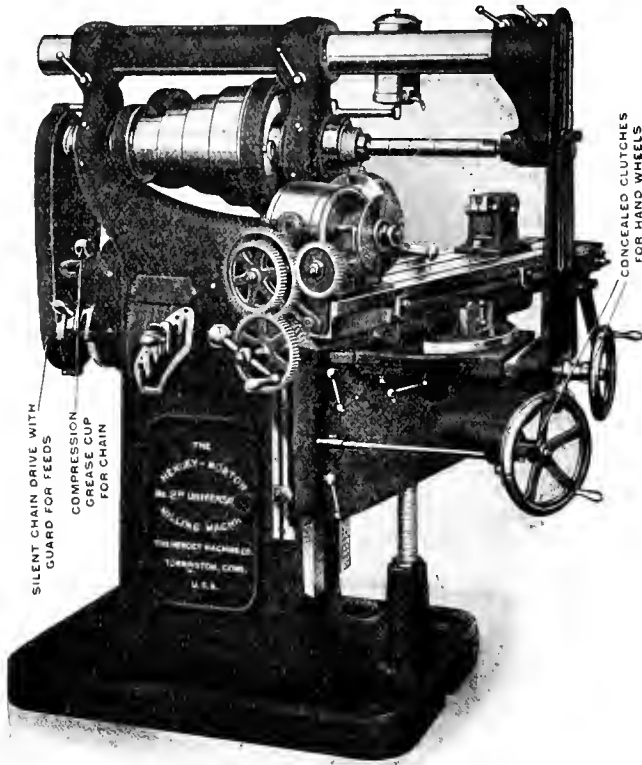

and it delivers the finished work in the highest degree of accuracy and perfection. It has a wide range of spindle speeds (16) and feeds (18).

The "Hendey" is free from the usual complicated features. All working positions are secured with but few and easily understood movements on the part of the operator. Anyone can operate the "Hendey Miller." No special skill is required to get the service that the Hendey's built for.

Write for the "Hendey Miller" Book. It is certain to interest you.

The Hendey Machine Co. Torrington, Conn., U.S.A.

Canadian Agents: A. R. Williams Machinery Co., Toronto, Ont.; A. R. Williams Machinery Co., 260 Princess St., Winnipeg; A. R. Williams Machinery Co., Vancouver; A. R. Williams Machinery Co., St. John, N.B.; Williams & Wilson, Montreal.

INDEX TO ADVERTISERS

<p>A</p> <p>Adams, Ogden R. 98</p> <p>Aikenhead Hdwe. Co. 63</p> <p>Albany Pump Co. 64</p> <p>American Pulley Co. 88</p> <p>Armstrong Bros. Tool Co. 96</p> <p>Armstrong, Whitworth of Canada. 7</p> <p>Atkins, Wm., & Co., Ltd. 13</p> <p>A.S.K. Chemical Co. 67</p> <p>Atlas Crucible Steel Co. 10</p> <p>Aurora Tool Works 105</p> <p>B</p> <p>Babeock & Sons 94</p> <p>Baird Machine Co. 61</p> <p>Banfield, E. J. 16</p> <p>Banfield, W. H., & Sons 65</p> <p>Barnes, W. E., & John 105</p> <p>Barnes, Wallace, Co. 65</p> <p>Bath & Co., Cyril, J. 70</p> <p>Borthan, John, & Sons Co., Ltd. 1</p> <p>Brantford Oven & Rack Co. 67</p> <p>Bridgford Machine Tool Wks. 5</p> <p>Bristol Company 95</p> <p>Brown, Boggs 11</p> <p>Brown Engineering Corp. 75</p> <p>Brown & Sharpe 101</p> <p>Brownell Machy. Co. 72</p> <p>Brown's Copper & Brass Rolling Mills 83</p> <p>Buden, Hanbury A. 64</p> <p>Butterfield & Co., Inc. 93</p> <p>C</p> <p>Can. Bond Hanger & Coupling Co. 89</p> <p>Canada Machinery Corporation Outside back cover</p> <p>Canada Wire & Iron Goods Co. 76</p> <p>Can. B. K. Morton Co. 4</p> <p>Can. Fairbanks-Morse Co. 34</p> <p>Can. Desmond-Stephan Mfg. Co. 81</p> <p>Can. Drawn Steel 96</p> <p>Can. Economic Lubricant Co. 89</p> <p>Can. Inspection & Testing Laboratories, Ltd. 95</p> <p>Can. Metal Products, Ltd. 75</p> <p>Can. S. K. P. Co. 31</p> <p>Can. Steel Foundries, Ltd. 7</p> <p>Can. Welding Works, Ltd. 109</p> <p>Carborundum Co. 8</p> <p>Carlyle Johnson Machy. Co. 8</p> <p>Chapman Double Ball Bearing Co. Front Cover</p> <p>Cincinnati Iron & Steel Co. 24</p> <p>Cincinnati Pulley Machy. Co. 107</p> <p>Cleveland Twist Drill Co. 103</p> <p>Corbet Foundry & Mach. Co. 18</p> <p>Cook, Asa S. 96</p> <p>Cullen Machy. Co., C. W. 70</p> <p>Cushman Chuck Co. 97</p>	<p>D</p> <p>Davenport Loco. Works 18</p> <p>Davies-Bourneville Co. 86</p> <p>Davis, W. F., Machine Tool Co. 73</p> <p>Deloro Smelting & Refining Co. 12</p> <p>De Mooy Mach. Co. 197</p> <p>Dept. of Finance 159</p> <p>Diamond Saw & Stamping Works. 87</p> <p>Dodge Mfg. Co. 84</p> <p>Dominion Forge & Stamping Co. 86</p> <p>Dominion Iron & Wrecking Co. 86</p> <p>Dominion Machinery Co. 125, 71</p> <p>Dominion Steel Foundry Co. 95</p> <p>E</p> <p>Eastern Mach. Screw Corp. 91</p> <p>Elmes, Chas. F. 26</p> <p>Eric Foundry Co. 76</p> <p>F</p> <p>Fetherstonhaugh & Co. 64</p> <p>Fitzgerald, W. H. J. 72</p> <p>Ford-Smith Machy. Co. 79</p> <p>Foss & Hill Machy. Co. Inside back cover</p> <p>Francis & Co. 97</p> <p>G</p> <p>Galt Mach. Screw Co. 71</p> <p>Gardner Machine Co. 97</p> <p>Garlock-Walker Machy. Co. 27</p> <p>Garvin Machine Co. 80</p> <p>Geometric Tool Co. 61</p> <p>Gibb Instrument Co. 111</p> <p>Gilbert & Barker Mfg. Co. 111</p> <p>Globe Machine & Stamping Co. 78</p> <p>Gooley & Edmund 78</p> <p>Grant Gear Works, Inc. 98</p> <p>Grant Mfg. & Machine Co. 103</p> <p>Greenfield Machine Co. 96</p> <p>H</p> <p>Hamilton Gear & Machine Co. 74</p> <p>Hamilton Machine Tool Works 23</p> <p>Hanson & Co., M. A. 14</p> <p>Hawkrige Bros. 66</p> <p>Hendey Machine Co. 116</p> <p>Himoff Mach. Co. 97</p> <p>Hepburn, John T. 17</p> <p>Holz, Herman A. 113</p> <p>Hoyt Metal Co. 98</p> <p>Hunzford Brass & Copper Co. 82</p> <p>Hurlbut-Rogers Machinery Co. 98</p> <p>Hyde Engineering Works 109, 91</p> <p>I</p> <p>Ideal Tool & Mfg. Co. 92</p> <p>Independent Pneumatic Tool Co. 31</p> <p>Iron Works, The 65</p> <p>J</p> <p>Jacobs Mfg. Co. 92</p> <p>Jarline Co., A. B. 107</p> <p>Jenckes Mach. Co. 9</p>	<p>J</p> <p>Jobbom, Geo. E. 67</p> <p>Johnson Mach. Co., Carlyle 8</p> <p>Joyce, Geo. A., Co. 97</p> <p>Jersey City Mach. Co. 98</p> <p>K</p> <p>Kasent, Limited 25</p> <p>KempSmith Mfg. Co. 85</p> <p>Kennedy, Wm., & Sons 16</p> <p>L</p> <p>L'Air Liquid Society 65</p> <p>Landis Machine Co. 96</p> <p>Latrobe Elect. Steel Co. 14</p> <p>Lyman Tube & Supply Co. 77</p> <p>Lynde-Paquinhar Co. 69</p> <p>M</p> <p>Macnab, John, Machy. Co. 20</p> <p>Marion & Marion 64</p> <p>Manufacturers Equipment Co. 90</p> <p>Marsh & Henthorn, Ltd. 76</p> <p>Matthews, Jas. H., & Co., Inc. 32</p> <p>McCabe, J. J. 22</p> <p>McCoy-Brandt Machy. Co. 70</p> <p>McDougal Co., R. Inside back cover</p> <p>McLaren, J. C., Bolting Co. 95</p> <p>Mechanical Engineering Co. 109</p> <p>Metalwood Mfg. Co. 27</p> <p>Metals Coating Co. 94</p> <p>Metal Drawing Co. 69</p> <p>Millers Falls Co. 84</p> <p>Miller, Smythe Elect. Co. 69</p> <p>Milliholland Co., W. K. 21</p> <p>Montreal General Tool Co. 22</p> <p>Monarch Brass Mfg. Co. 75</p> <p>Montreal Machy. & Supplies 101</p> <p>Molten Tool Co. 28</p> <p>Morton Mfg. Co. 66</p> <p>Murhey Machine & Tool Co. 91</p>	<p>N</p> <p>National Acme Co. 20</p> <p>National Machine Tool Co. 97</p> <p>New Britain Mach. Co. 67</p> <p>New York Machinery Exchange 71</p> <p>Nicholson File Co. 88</p> <p>Niles-Bement-Pond, Inside front cover</p> <p>Noble & Westbrook Co. 98</p> <p>Northern Crane Works 95</p> <p>Norton, A. O. 32</p> <p>Norton Co. 98</p> <p>Nova Scotia Steel & Coal Co. 6</p> <p>O</p> <p>Oven Equipment & Mfg. Co. 109</p> <p>P</p> <p>Parmenter & Bulloch Co. 98</p> <p>Perrin, Wm. R. 27</p> <p>Peerless Machine Co. 85</p> <p>Petrie, of Montreal, Ltd., H. W. 15</p> <p>Petrie, H. W., Ltd. 69</p>	<p>P</p> <p>Positive Clutch & Pulley Works 96</p> <p>Pratt & Whitney Inside front cover</p> <p>P'ringle, R. E. T., Ltd. 26</p> <p>Puro Sanitary Drink'g Furniture Co. 66</p> <p>R</p> <p>Racine Tool & Machine Co. 85</p> <p>Reed-Prentice Co. 33</p> <p>Rickett Shaper Co. 79</p> <p>Riverside Machy. Dept. 69, 70</p> <p>Rivett, Lathe & Grinder Co. 114</p> <p>Rockford Drilling Machine Co. 106</p> <p>Rockwell Co., W. S. 14</p> <p>Rodolofson Machine & Tool Co. 90</p> <p>Roper & Co., C. F. 86</p> <p>S</p> <p>Shore Instrument Co. 96</p> <p>Shuster Co., F. B. 85</p> <p>Silver Mfg. Co. 94</p> <p>Simmons Mach. Co., Inc. 19, 69, 71</p> <p>Skinner Churn Co. 26</p> <p>Stewart, Abram & Stearns 99</p> <p>Standard Alloys Co. 10</p> <p>Starratt Co., L. S. 81</p> <p>Standard Mfg. Co. 24</p> <p>Steecher Co., The, Chas. 21</p> <p>Steel Co., of Canada 3</p> <p>Stepto, John, Co. 78</p> <p>Stone Tool & Supply Co., J. R. 90</p> <p>Stocker-Rumley-Wachs Co. 73</p> <p>Stow Mfg. Co. 106</p> <p>Swedish Steel & Imperiaz Co. 14</p> <p>V</p> <p>Vanadium Alloys Steel 6</p> <p>Vulcan Crucible Steel Co. 14</p> <p>T</p> <p>T. C. M. Mfg. Co. 26</p> <p>Taylor Mfg. Co. 97</p> <p>Taylor Instrument Co. 111</p> <p>Timing Instrument Co. 113</p> <p>Toronto Iron Works 95</p> <p>Union Tool Chest Co. 97</p> <p>United States Electrical Tool Co. 20</p> <p>W</p> <p>Webber Bros. Machy. Co. 82</p> <p>Whiting Foundry Equipment Co. 78</p> <p>Williams, A. R., Machinery Co. 61</p> <p>Williams, J. H., & Co. 82</p> <p>Williams Tools Co. 60</p> <p>Windsor Mach. & Tool Works 17</p> <p>Winnipeg Gear & Engineering Co. 74</p> <p>Walton Co. 94</p> <p>Walcott Lathe Co. 25</p> <p>Wells Bros. Co., of Canada 20</p> <p>West Tire Setter 26</p> <p>Z</p> <p>Zenith Coal & Steel Products Co. 96</p>
--	--	--	--	---

Tool Holder and Cutting Tool Application Data--I.

By F. Scriber

The approaching return to broader and more general lines of manufacture render a study of tool-holders very timely. While the welded tip has found considerable application under recent conditions of heavy duty and unskilled operation, the obvious advantages of well designed tool-holders are such as to insure a continuance of their use, more especially where variety of work offers increased efficiency opportunities for well assorted equipment.

A QUESTION of vital importance with the ever-increasing cost of high-speed tool steel is the matter of the tool detail to be employed in the cutting of various metals. This item of machine up-keep is part of the daily

development have built up objections which have tended to keep them from reaping many of the advantages which these tools surely possess. A tool-holder properly designed is rugged enough to withstand ordinary shop usage except under especially heavy cuts, and, by its use, a large part of the high-speed steel cost is got rid of. In addition to this, a good deal of "blacksmithing" is done away with; the inserted blades are usually easier to grind, as in most types of holders the cutters are held with the proper rake and clearances, and, consequently, this need not be considered when grinding the blades. The accompanying illustrations show a collection of tool-holders which are practical and well adapted for the work that they are intended to perform. Quite a number of the holders described are standard tools, which can be purchased in the market and these are, of course, tools of proven ability.

compact, and consequently many attempts have been made to duplicate one-piece tools in simplicity, while reducing their cost. Examples of the general trend of this practice are shown in Fig. 4, the high speed portion of the tools be-

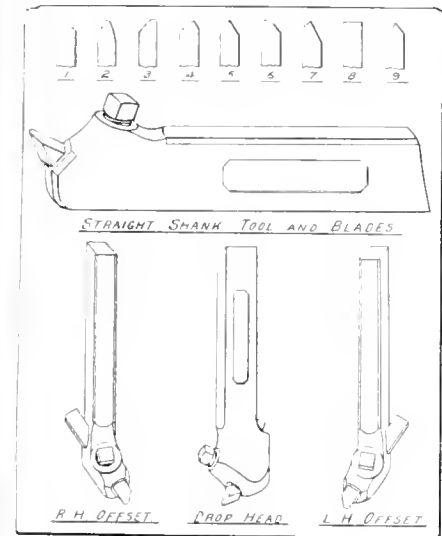

FIG. 1.

shop maintenance, and cannot be entirely eliminated, but by careful planning it may be reduced to an absolute minimum. With this object in view, the tendency in late years has been to make the actual cutting tools in the form of an inserted blade which, when mounted in a suitable holder, is stiff; this permits of using most all of the tool and, in consequence, there is very little waste.

The practical limitations of these tools are quite generally understood, but many manufacturers who have had experience with them in the early stages of their

Referring to Fig. 1, this illustration shows an Armstrong tool-holder suitable for lathe work and planing. Cut shows a straight shank tool-holder, and the lower views show a right-hand offset, a left-hand offset and a drop head tool-holder, while the view at top of the illustration shows a number of cutters which may be held in these holders. From this collection it is possible for one to pick out cutters which are suitable to quite a variety of work on which one-piece form tools are extensively employed. From a study of these holders it is obvious that there are three common positions in which the cutters are set—at right angles to the work, those set to the left of this position, and those that set to the right.

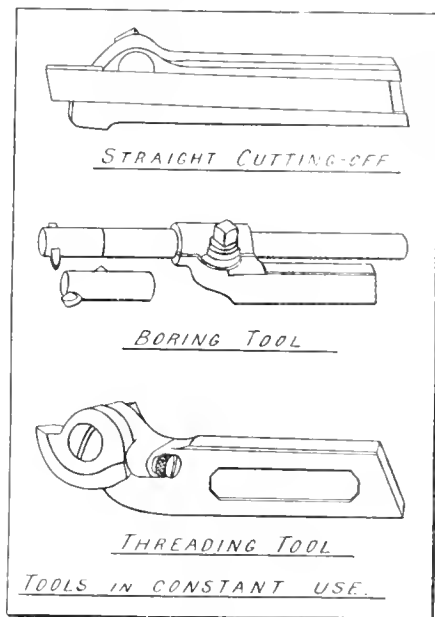

FIG. 3.

ing shown in section. The main portion of the holder or shank is made of machinery steel, while the various types, namely, Broad Nose, Round Nose, Diamond Point, and Side Tool, are welded to the shank, thus providing what is prac-

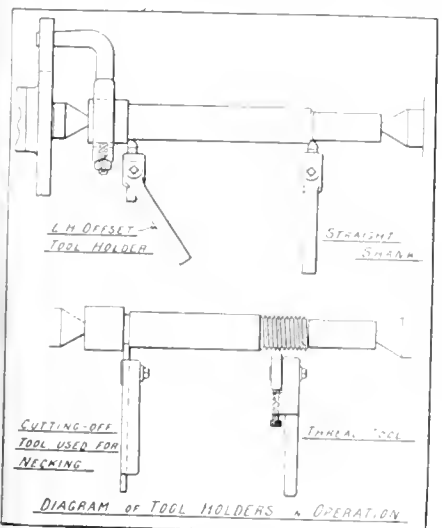

FIG. 2.

Referring to Fig. 2, the upper view shows a left-hand-offset tool at work turning a piece of round stock in a lathe; a straight shank tool-holder working under the same conditions is also shown. In the lower view of this same illustration, a straight shank cutting-off tool is shown at the left, being used for necking a shoulder, and, in the lower view at the right, a straight shank threading tool is shown in operation. These two latter tools are shown more complete in Fig. 3. The upper view there shows the cutting-off tool, while the lower view shows the threading tool; the illustration in the middle shows a standard type of boring tool. All of the foregoing tools hold cutters, which are simple to make, are rigidly held in position, easily replaceable, and can be used under quite a variety of conditions while providing for the minimum waste of expensive material.

One-piece tools, of course, are quite indispensable for some classes of work, such as getting into corners, as they are

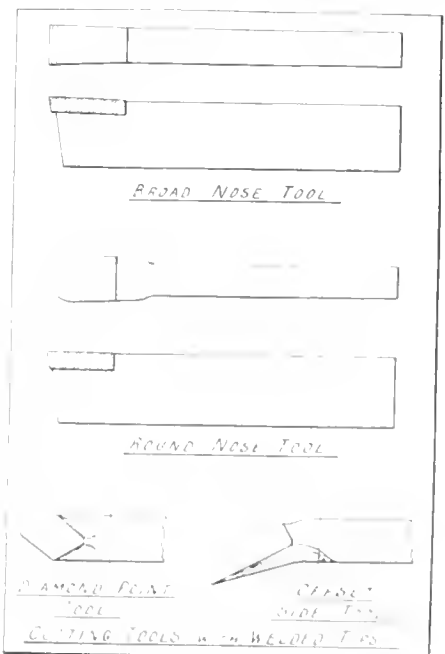

FIG. 4.

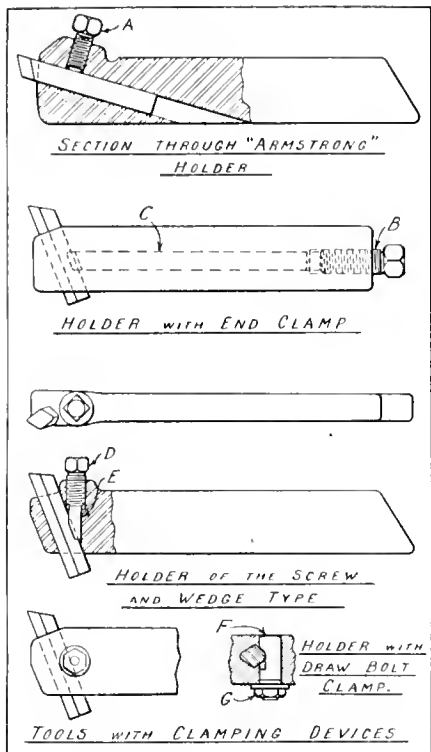

FIG. 5.

tically a one-piece tool combining the advantages of a high-speed cutting tool, with, at the same time, the compactness of a one-piece tool.

Returning again to the subject of inserted tool-holders, Fig. 5 shows a section through an Armstrong holder. The cutter in this tool is inserted on an angle to give the correct cutting rake, and is clamped by the screw A. The second view in this illustration shows a cutter which is clamped by a screw in the holder B, this screw being made to bind the cutter by means of the shoe C. The third view from the top illustrates a tool-holder, which has the cutter set in practically the same as the above, but clamped by means of the screw D, which forces the wedge E against the cutter, thus binding it.

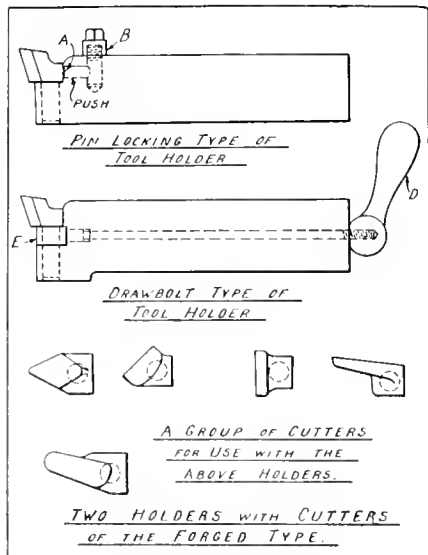

FIG. 6.

Referring to the lower view, the cutter is clamped by means of the familiar draw-bolt construction F, the bolt being cut out to clamp against one side of the cutter when the nut G is tightened. Other tool-holders which work on this principle lock the cutter by means of bushings, while still other holders clamp the blade by having the holder split and using a binding screw. It will be quite unnecessary to show all of the constructions which are found suitable for this purpose, illustration and description of the general principles involved being sufficient for our present purpose.

While most tool-holders are constructed with the idea of using blade stock of standard shapes, in recent years, owing to the fact that there are quite a number of odd shapes of steel being placed on the market which can be very conveniently held in tool-holders, this condition has been taken advantage of in a number of instances and, therefore, we find numerous tool-holders made to grip special shaped stock.

In other types of holders, the makers have gone into the subject still further, and have made the tool points or cutters special drop forgings adaptable to special holders only. Two holders based on this plan are illustrated in Fig 6, the upper one being a holder which has the point locked by a pin; this pin clamps at the back side of the cutter A when the screw B is tightened. The other holder illustrated has a draw bolt C running through it, which is tightened by the handle D at the end of the holder, and in the latter the cutter is bound on the shank E. A group of cutters or points, which may be used for a variety of work, and are held in these holders, are shown below in this illustration.

The tool-holders shown in Fig. 7 are somewhat different from the foregoing, inasmuch as the one in the upper view shows a cutter which is bound by a tapered wedge A. This cutter B has teeth cut in it to engage with the teeth in the wedge and, of course, the heavier the cut the tighter the wedge will grip, as the wedge is forced down in the holder by the cutting action as the blade "takes the cut." Care must be taken in using a tool of this type to have the wedge securely lock the cutter before starting to machine the work. The lower views on this illustration show a tool with an adjusting screw in back of the cutter; this screw permits of fine adjustments being made, and the screw C binds the cutter in the same manner as in some of the tools previously described. Adjusting screws are by no means confined to this particular type of tool, nor is it necessary to apply them in this particular manner, but they are employed in quite a variety of ways by different designers.

Reference was made at the beginning of this article to the fact that the blades were usually held at right angles to the work, or to the right or left of this position, but, in Fig. 8, we have a holder where all of these positions are obtained in one tool. The manner of accomplish-

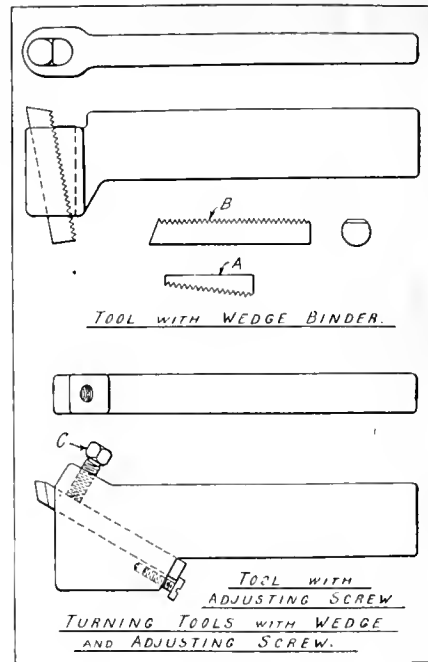

FIG. 7.

ing this is obvious, as there are three slots cut in the holder, and the cutter may be presented to the work from the slot which is most convenient. The cutter in this holder is clamped in any position by means of the screw A, which bears on the cutter at the intersection of the slots.

A tool-holder which contains two cutters is shown at work in the lower view of Fig. 8. The cutter B is of round nose type and the cutter C is a necking tool. These cutters are clamped by independent screws D and E in any convenient manner, the particular type here shown being the familiar set screw method of clamping.

In the succeeding articles of this series the subject will be enlarged upon, so as to take care of cutting-off tools, threading tools and boring tools as inserted blades in tool-holders.

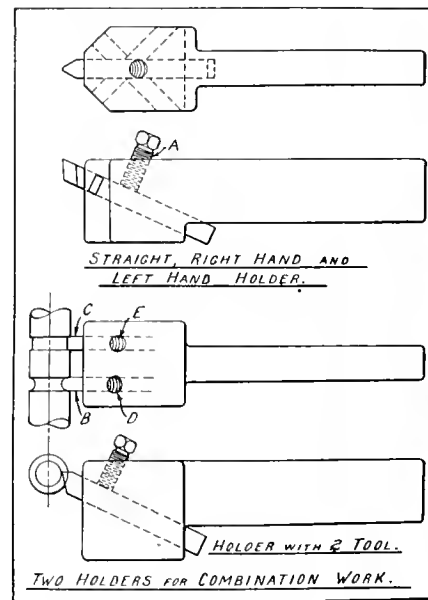

FIG. 8.

PRODUCTION METHODS AND DEVICES

A Department for the Interchange and Distribution of Shop and Office Data
and Ideas Evolved from Actual Practical Application and Experience

SPECIAL DESIGN THREAD MILLING MACHINE

By R. Hamilton.

THE specifications requirements in connection with the appearance and accuracy of the thread portions of the various types of shell, have been the means of developing many special attachments and machines for satisfactory accomplishment. Collapsible taps have been, and still are, largely used for the accomplishment of this operation, but the hobbing process has made remarkable progress since the inception of the shell industry. Many makes of thread millers have been placed on the market, but the magnitude of the munitions industry, and the inability of the many firms to secure the desired equipment in a special time, has resulted in a large number of plants solving this problem on their own behalf, that is, by designing special devices or machines to offset the delay arising from abnormal production and transportation conditions. In many respects, the situation of the past two years has enabled Canadian manufacturers to make wonderful progress along the lines of more rapid and economic production. There is an old saying that "Necessity is the Mother of Invention," but the value of time has been such an outstanding factor in shell production that the phrase might well be changed to read "Necessity is the Brother of Invention," as necessity and invention have travelled hand in hand during the busy months of the war,

making it practically impossible to stay the development of ideas.

The accompanying half tones and line drawing illustrate a special thread milling machine designed and constructed

ing. Fig. 1 shows a front view of the machine, while Fig. 2 is the same machine from the rear. The double spindle milling head is fitted to a fixed cross slide, the back end being supported by



FIG. 2. SPECIAL THREAD MILLING MACHINE—REAR VIEW.

by the Canadian Ingersoll-Rand Co., for milling and hobbing the adapter threads in 8 inch high explosive shell. The operation of counterboring and recessing, and the hobbing of the thread are performed at one setting, thus eliminating the possibility of eccentricity in the various diameters, and insuring a more accurate fit when screwing in the adapters. The machine is so constructed as to give one speed for milling and hob-

an auxiliary slide rail secured to the machine bed. The lateral movement of the head is obtained by the handle 1, while the cutters are adjusted to working position by the handles 2, 2, each cutter spindle operating on an independent slide, and the shafts sliding through the gears retained in the housing (3). The rear spindle carries the standard milling cutter for milling the counterbore and recess, and the front spindle carries the thread hob. The entire milling head has a similar action through the right angle gear drive. The outer bearing for the driving shaft is supported by an extension from the bed of the machine, shown in the rear view Fig. 2. Suitable stops shown at (4) are arranged on the side of the cross slide to determine the depth of each cutter.

The arrangement of the head stock, with the operating mechanism, is shown in Fig. 3. By means of a train of gears, the spindle and the shell are revolved at a constant speed, both for milling the counterbore and recess, and also the hobbing of the thread. On the opposite end of the drive shaft that carries the pulley A is secured the worm that drives the worm gear C, these being retained in the casing B. The driving pinion D, which is cut in the shaft, engages with the intermediate gear E keyed to the shaft F. The main gear G is cast integral with the spindle II. This spindle has a lateral movement which will be described later. The forward portion of the spindle carries the

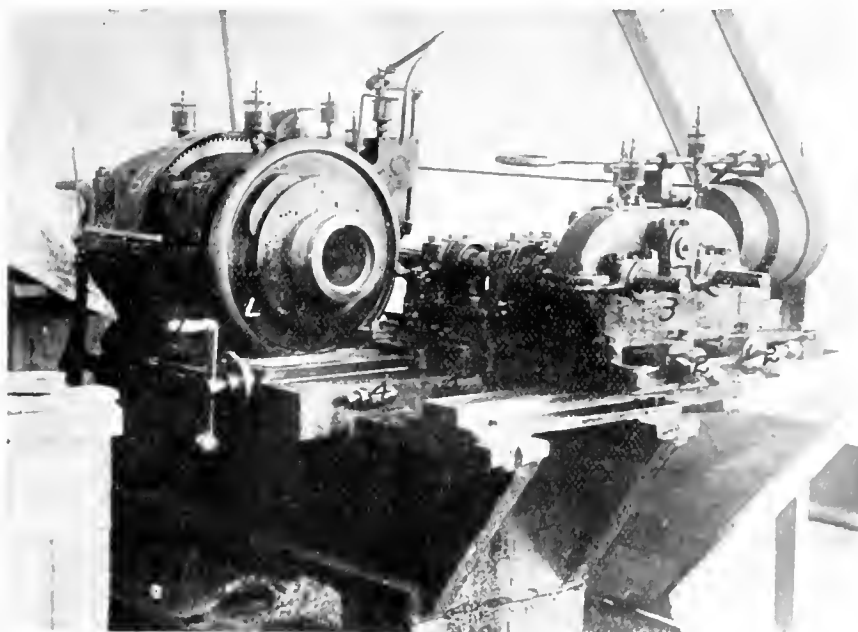

FIG. 1. SPECIAL THREAD MILLING MACHINE FRONT VIEW

chuck; the piece I being firmly secured to the end. The collet ring J which is threaded to the piece I, operates the split ring jaws K by means of the hand wheel L. Within this wheel is contained a pawl M that engages notches cut in the ring J, by which the chuck is tight-

operator neglect to disengage the lateral feed after it has accomplished its object, he is warned by the ringing of a small bell, located on the rear bearing cap, shown at D', Fig. 2. Before the next operation is commenced, the fixture is returned to its original position by means of the handle on the arm W.

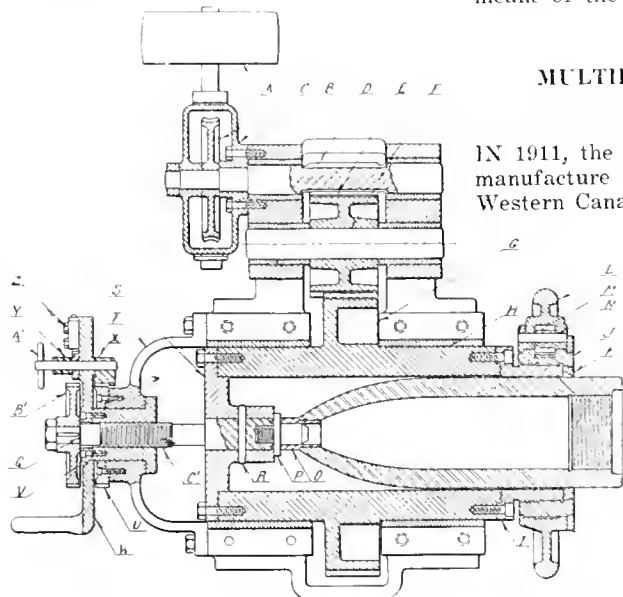

FIG. 3. SPECIAL THREAD-MILLING MACHINE DETAIL.

ened or released. To retain the shell in proper alignment, the inner end is supported on a special bush O fitted to the nose and placed on the plug P, which in turn is screwed in the end of the shaft Q. By means of a tapered pin R, this shaft is rigidly secured to the piece S, that fits on to the end of the main spindle.

Fitted to the end of the rear housing is the bracket T, which supports the lateral feed shaft Q and the operating gearing. The ratchet wheel U is bolted to the bracket T, and always remains stationary in relation to the machine frame. Bolted to the nut V is the arm W; one end carrying the two pawls X and Y, the other provided with a handle for returning to initial position. The pocket Z contains the spring that keeps the pawls to their respective positions these being set by the handle A'. The ratchet wheel B' is keyed to the end of the shaft Q, the threaded portion C' fitting the nut V, and being of the same pitch as the thread to be cut, in this instance, 1/8 inch. When the counter-bore and recess are being milled, the pawl Y is engaged with the wheel B', causing the shaft and the nut to revolve together, with no lateral movement in shell position.

After the base is prepared for the thread, and the hob brought to position, the handle A' is moved to disengage pawl Y and engage pawl X with wheel U; this keeps the arm W and the nut Y stationary, resulting in the shaft Q revolving in the nut, thus slowly drawing the spindle and shell backwards at the rate of 1/8 inch per revolution while the hob is cutting, so that, when the spindle has made a little over a turn, the thread has been cut. Should the

operator neglect to disengage the lateral feed after it has accomplished its object, he is warned by the ringing of a small bell, located on the rear bearing cap, shown at D', Fig. 2. Before the next operation is commenced, the fixture is returned to its original position by means of the handle on the arm W.

— ⚙ —
MULTIPLE DRILL HEADS
 By H. Street

IN 1911, the writer was engaged in the manufacture of gasoline engines in Western Canada and, at that time, practically none of the modern productive methods had made their appearance in that locality. True, high-speed lathe tools were used to some extent, but high-speed drills were practically unknown. Slip chucks, tapping attachments, gear cutters, micrometers and other now indispensable tools had not made their appearance. Any job work was usually completed by the man who

started it regardless of the various operations encountered. Each man kept whatever drills and other small tools he used carefully under lock and key or hidden beneath some convenient bench, while any extra drills and reamers were

to be found in the office. No drawings were in existence, all work being done according to sample. Dimensions for the various engine parts were to be found, however, on the walls above the workman's benches, in blue chalk, having been placed there by the workmen for

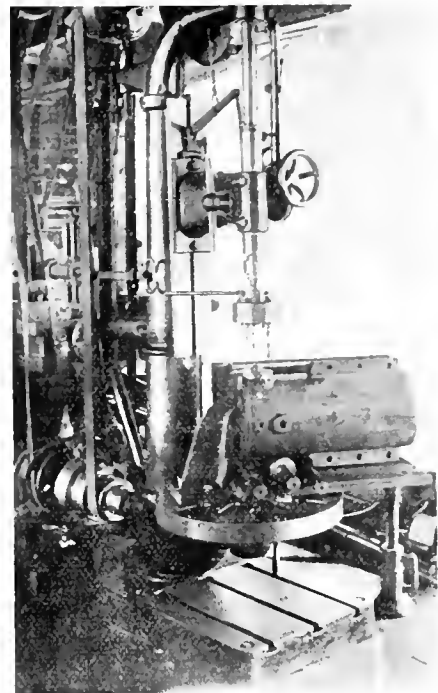

FIG. 2. MULTIPLE DRILL HEADS.

their own convenience. All drilling was done on the machine shown in the cut and, as engines up to twenty-five horse power were built, some of the difficulties in connection with this class of work may be imagined.

Quite a large number of one and one-half horse power engines were built, these having an air-cooled cylinder, held to the base by four studs of three-eighths inch diameter. The multiple head shown in Fig. 1 was constructed to drill these stud holes, both in cylinder and base. Taper shank drills were used and the spindles extended sufficiently from the body so that the drills could be removed from below. The upper part of the body was split and clamped directly on the sleeve, being prevented from turning by the rack on same. The central driving gear was cut directly on the taper shank and had a bearing in the lower half of the case but none in the upper. In attaching, this central shank was simply pulled out and inserted in the spindle, and the body then slipped over this and clamped in position. The spindles were provided with fiber thrust washers and lock nuts to take the separate drill thrusts, these, of course, being transmitted directly to the sleeve.

The shop in which these heads were made was not fortunate enough to be provided with a milling machine of the modern type nor a dividing head. An old Lincoln type miller was used, and the spindles held in V-blocks while cut-

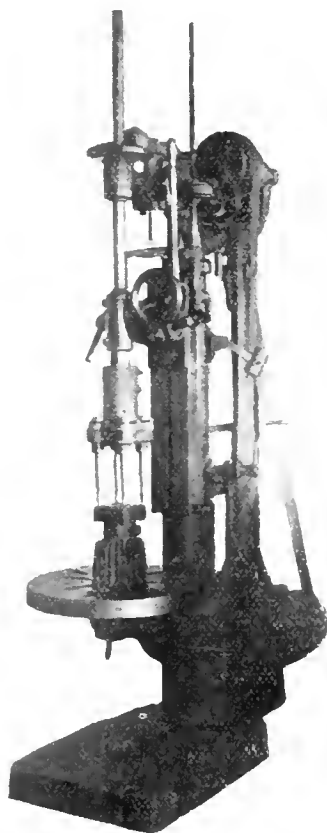

FIG. 1. MULTIPLE DRILL HEADS.

ting the teeth of the gears. The spindles were left somewhat longer than necessary and a lathe change gear of the requisite number of teeth was attached to this extension which, after the teeth were cut, was removed. A small set screw with lock nut in an angle plate, acted as a dividing head, the tapered point of the screw being run into the teeth of the lathe gear. In order to set the milling cutter to the proper depth, an ordinary one inch outside micrometer was used; with the cutter just touching the blank, a small block was set under the arbor of a height such that the micrometer could just be slipped in under the arbor. The

spindles carrying the drills were quite short, extending below only sufficiently to carry the two locknuts and a fiber thrust washer. The combined drill thrusts in this case were thus transmitted directly to the center spindle and this was provided with a large collar and thrust washer resting on the top of the case. The taper shanks of the drills extended up into the upper bearings in which were located the tang slots. It was thus impossible to use a drift for removing the drills and, to perform this operation, a hole was tapped in the upper end of the spindle, into which a set screw could be placed and the

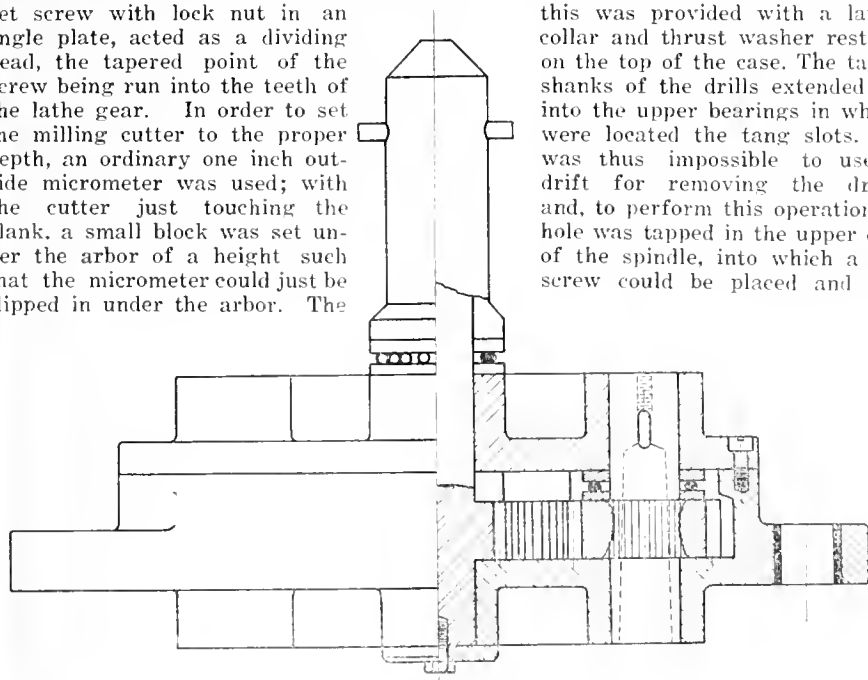

FIG. 3. MULTIPLE DRILL HEADS.

sleeve was then turned down the proper amount and the head lowered until the arbor again touched. This was similar to using an inside micrometer and proved just as satisfactory. By using a little care an excellent job was obtained. The holes in the body were laid by off means of buttons and micrometer so that these could be very accurately bored. No trouble whatever was experienced in assembling, and it is safe to say that a first-class tool room could not have produced a more satisfactory piece of work.

The head just described having proven such a success, that shown in Fig. 2 was next designed. This was for drilling the three holes for the studs holding the make-and-break igniters in the larger cylinders. These holes were properly spaced in relation to the face of the cylinder by the self-centering jig also shown in the photo. This head was provided with a shank to fit a 1 1/4 inch Magic chuck, and it was thus impossible to attach the body solidly to the sleeve to prevent the rotation of the same. It was desirable to use the slip chuck as these holes were drilled at the same time as the main hole was bored. The rotation of the body was taken care of by the arm seen resting against the column of the drill press. In order to facilitate finishing, the body of the head was made round, and a collar into which this arm was threaded was slipped over the upper part and locked by means of a setscrew. It was thus possible to set the drills in any angular position called for by the jig. The body of the head was, of course, made in two parts and held together by cap screws. The

drill forced out. This is more clearly shown in Fig. 3.

Fig. 3 shows a head which was designed to be used in connection with other tools on a crank case for a multiple-cylinder engine. The crankshaft was provided with three bearings, but the spacing of the stud holes lengthwise of the shaft was different for each bearing, so that it was impossible to drill more than two holes at a time. The head was used in connection with a Wizard chuck and, to prevent rotation of the body, two pins were fastened solidly in the jig plate just outside of the stud holes; these pins extended up into bushings which were carried by projections at each end of the head. By bringing the drill head down over these pins, the drills were accurately located. It was, of course, necessary that the pins be slightly longer than the drills used and, for this reason, the drills were kept as short as possible. A ball thrust bearing was placed over the gear on each spindle and a larger bearing transmitted the combined thrusts to the main spindle. In this case, as in the previous one described, the drills were forced out by means of a screw in the upper end of the spindles.

In all the heads described, idler gears were used so that the regular drill spindle could operate in the normal direction. Many times, of course, it is possible to dispense with these idlers but in most cases it is not advisable.

BORING AN IGNITER HOLE

By D. O. Barrett

IN the gasoline engine of which the cylinder shown in the cut was a part, make-and-break ignition was used, the igniter being placed in a bored hole in the side of the cylinder, and extending into the combustion chamber. The hole was of two dimensions, 2 1/8 inches in diameter at the inner end and 2 3/8 inches at the outer; the shoulder thus formed was finished to a 45 degree bevel, the igniter body having a corresponding shoulder so that a ground seat could be obtained at this point for maintaining the pressure developed in the cylinder. The upper part of the hopper or jacket used on these cylinders was removable, hence this face on the cylinder casting was planed and drilled and tapped so that the casting could readily be held by these holes as the operation of boring the igniter hole was the last to be performed. The work had previously been done on a large wheel lathe by bolting the angle plate shown in the cut to the regular face plate. This plate was about six feet in diameter and the lathe was speeded accordingly, so that one could imagine the length of time necessary to complete the operation. It was also quite a job to centre the cylinder, as this had to be done fairly accurately.

This same angle plate was used on the drill press and supported at the outer end by a jack screw as the excessive overhang would tend to distort the press table. Cap screws were used to hold the cylinder, into the tapped holes previously mentioned. Two roughing bars were provided for the two sizes of

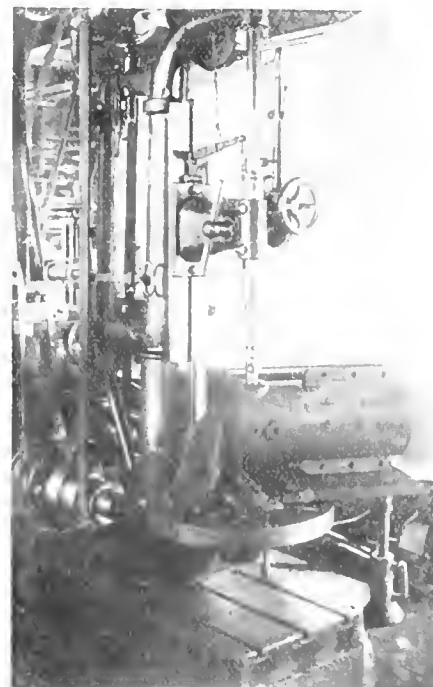

BORING AN IGNITER HOLE.

hole. These were used in the regular Magic chuck, and were further supported by a bushing in the bracket bolted to the drill press table, and which ex-

tended into the cylinder the correct distance. Deep chip grooves were milled in the ends of the bars, and leather washers were used to prevent chips getting into the lower bearing. Double ended cutters were used in both instances in order to maintain the size. The smaller cutter was slightly oversize to allow a slight clearance, which was necessary, while the larger was slightly undersize to allow a final finishing cut to be taken by the bar which is shown in position. This final cut was taken by a single-ended tool and was kept quite close to size. The front face of the cutting tool was ground to a 45 degree angle in order to finish the seat in the one operation. The bar above the cutter was threaded and two lock-nuts provided, these acting as a depth gauge. Power feed was used down quite close to depth, with hand feed for the final finish, the stop collars being brought down against the outer face which had previously been planed the correct distance from the center of the cylinder.

After boring and finishing, three $\frac{3}{8}$ inch holes were drilled and tapped in

shown in the accompanying drawing was designed. It was desired that the shafts be clamped directly at the point of cut, if possible, and this was accomplished by means of the two forged clamps which were hinged at the bottom, the hinge-pins running through the two bosses shown. The block itself was held to the milling machine table by a clamping bolt at either end; the tongue for the bolt slot was planed up solid with the block. The two clamps were drawn together by the T-head bolt passing through the block, a slight pressure always being retained against the nut by a spring set into the block and bearing against the washer near the end of spring set into the block and bearing against the washer near the end of the bolt. When it was desired to remove a shaft, the nut was only slightly loosened and the T-head given a quarter turn, when it would pass through the clamp on the one side. This would drop completely down and it was then only necessary to lift the shaft just over the top of the block itself. No clamps were used on the other end of the shaft, this resting in a correspond-

line, 3.93 miles; London terminals, 0.62 miles.

Algoma district possesses a mileage of 180 of double tracks, running between the following points: Romford Junction to Sudbury, 6.80 miles; Azilda to Geneva, 30.20 miles; Roberts to Woman River, 25.90 miles; Nemegos to Esher, 25.50 miles; Healy to Bolkow, 19.10 miles; Depew to King, 27.10 miles; Heron Bay to Peninsula, 8.40 miles; Selim to Pays Plat, 13.70 miles; Cavers to Gurney, 11.00 miles; Fire Hill to Ruby, 4.20 miles; Navilus to Port Arthur, 8.10 miles.

Manitoba district is laid with no less than 643 miles of double tracks. Port Arthur to Winnipeg, 426.30 miles; Winnipeg terminals, 23.20 miles; Winnipeg to Virden, 179.20; Whitewood to Broadview, 14.30 miles.

Saskatchewan district has 210.20 miles of double track, 16 running between Broadview and Grenfell and 194.20 between Indian Head and Swift Current.

Alberta district has 12.20 miles of double track, six running between Swift Current and Java, and there are 6.20 in Calgary terminals.

British Columbia district is equipped with 143.90 miles of double track, distributed thus: Connaught to Glacier, 5.80 miles; Revelstoke to Taft, 24.20 miles; Pritchard to Kamloops, 24.10 miles; Kamloops to Tranquille, 8.70 miles; Ruby Creek to Vancouver, 81.10 miles.

Alternative routes are also in operation between several points, and they are practically equivalent to double tracks.

In all there are 489.40 miles of railroad offering alternative routes. Double tracks and alternative routes are parts of the facilities which make the Canadian Pacific the greatest transportation system in the world.

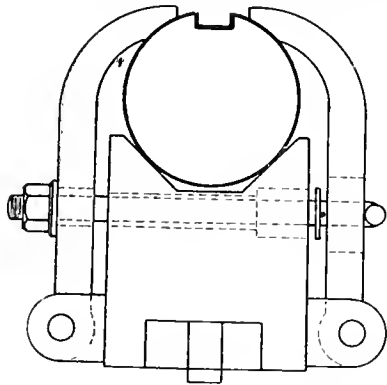

VEE-BLOCK FOR KEYSEATING.

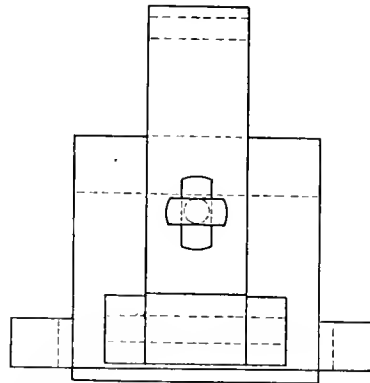

the face for the igniter studs. These holes were drilled, using a multiple spindle drill head which slipped into the Magic chuck and which is described in the Multiple Drill head article also appearing in this issue. This head could be swiveled about the spindle and locked in any position so that it was not necessary that the angle plate be placed in any fixed position in this respect. A self-centering jig was used for locating the holes, and these were also squared up with the turned end of the cylinder as it was necessary that a line through two of the holes be parallel with the center line of the cylinder. This jig was described in our issue of December 17, 1914.

Needless to say, a great saving in both time and patience on the part of the operator was effected, and the resulting job was better and more accurate, as all sizes were obtained without the necessity of calipering or measuring.

V-BLOCK FOR KEYSEATING

By A. S. Loy

HAVING a large number of shafts of a certain size to keyseat, the V-block

ing V-block with the end against an angle plate to take the thrust of the cut. Due to the fact that the clamps rested on the upper part of the shaft, a large resultant pressure was thus obtained.

SOME C. P. R. FACTS

THE Canadian Pacific Railway has a grand total of 1,500.36 miles of double track, which is greater than that of all the other Canadian railways added together. A statement just issued shows that in Quebec there are 205.11 miles distributed thus: Montreal (Windsor Street) to Smiths Falls yard, 129.20 miles; Montreal West to Brigham Junction, 44.79 miles; Montreal West to Mile End, 7.11 miles; Montreal (Place Viger) to Ste. Therese, 20.11 miles; and Montreal terminals have a mileage of 3.90.

Ontario district has a double tracked mileage of 105.95, made up as follows: Smiths Falls to Glen Tay, 14.84 miles; Agincourt to Leaside, 7.58 miles; Don to Parliament Street, Toronto, 0.78 miles; Toronto to Guelph Junction, 39.10 miles; Toronto (Bathurst Street junction) to Hamilton, 39.10 miles; North Toronto

DETINNING APPARATUS

PRIOR to the war, steel scrap in the form of cans, etc., was shipped from England to Germany for removing the tin, solder and zinc. The following apparatus has been recently patented in England to do the work at home. It consists essentially of a slowly rotating inclined cylinder and a stationary hopper with a sleeve encircling the rotating cylinder. The latter has a feed aperture which once in every revolution registers with the aperture on the hopper and allows the cans to be fed into the internal heating chamber. To reduce the friction the latter is mounted upon roller bearings. The heating is effected by gas or oil burners. The heating chamber is surrounded by a firebrick-lined cylinder with outlets for the products of combustion through the short flues at the top. Cans feed into the heating chamber, gravitate slowly through as the chamber rotates, and eventually find their way to the outlet, where they pass down the chute. The temperature is gradually raised along the length of the chamber and is the highest at the outlet end. In the interior of the heated chamber channels are formed for collecting the molten tin and solder.

Worm Gear Design Features and Worm Gear Mounting Detail*

By F. W. Lanchester

Progress that may almost be classed as extraordinary in worm gear design and arrangement is largely due to the research expended and inventive genius displayed by interests responsible for the now front rank prominence of automobile engineering.

IN a paper read before the Institution of Automobile Engineers in 1913, the author dealt with the subject of worm gearing broadly, and more particularly with the Lanchester worm gear, which was the first to be successfully introduced in automobile practice.

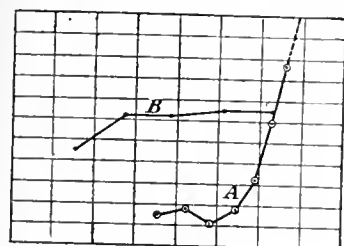

FIG. 1.

It is, perhaps, unnecessary here to recapitulate the distinctive features of worm gear of different types, being enough to say that at the present time there are, broadly speaking, two types of worm gear in competitive employment—the Lanchester gear, which may be spoken of as a variant of the Hindley worm, and the cylindric, parallel, or straight worm such as that marketed by Messrs. David Brown & Sons, Messrs. Wrigley, and others, which may be taken as a development of the ordinary worm gear in common use by engineers for a century or more. Although on the one hand, the Lanchester gear is described as a form of Hindley, and the parallel or cylindric worm as that of ancient practice, such descriptions do not entirely do justice to either the one or the other.

Worm Gear for Power Transmission

Worm gear for power transmission (where mechanical efficiency is the talisman of success) is a comparatively modern development, and the gear used to-day in motor-car transmission and in other cases of power transmission, such as electric lifts, hoists, etc., bear but a very faint resemblance to their fore-

runner, which was designed and used for motion transmission alone. Indeed, it is correct to say that, in the more ancient applications of worm gear, a common condition was that the drive should be irreversible; in truth, it was when such drive was wanted, as in a hand winch, that the engineer turned his thoughts to the worm wheel as a solution. It is a point of importance that, so long as this irreversibility is a condition, the mechanical efficiency as a power transmitter cannot exceed 50 per cent. We may, therefore, take it that although it may be difficult to draw a hard and fast line between the worm gear of old and the worm gear of to-day, there is, from the practical point of view, as complete a break of continuity as if such a hard and fast line existed.

Transmission Efficiency

Thus, in the case of motion transmission, it was uncommon for worm gear to have an efficiency higher than 30 per cent. or 40 per cent.; but immediately the problem is changed to that of economic power transmission and the engineer concentrates his attention on the question of mechanical efficiency, a duty as high as 94 per cent. or 95 per cent., or, as shown in the previous paper, even 97 per cent., is to be obtained. In the previous paper the question of efficiency was made the pivot point of the discussion, and the result of the tests made by the staff of the National Physical Laboratory at the Daimler Works were freely used. In the present paper the maker of the gear of parallel type which has been used as a comparison is definitely given; it is the gear of Messrs. David Brown & Sons, obtained direct from one of their customers. It is presumably a fair sample of the gears supplied by that firm. It is of course, more satisfactory to be able to state the maker of the gear which has been subjected to investigation.

The present paper naturally divides itself into two parts—the first part relates to a detailed discussion of the theoretical side of the subject, and may be taken as supplementary to the discussion of the previous paper; the second part relates to a practical examination of the “solid geometry” of worm gear by a new method, and is in fact a detailed comparison of the Hindley and parallel types of worm gear as exemplified in the Lanchester and David Brown respectively. A third section of the paper is devoted to the question of worm gear mounting or housing, a feature in which the practice in respect of the two types does in certain respects present differences.

Part I.

There are a great number of variables—an inconveniently great number of variables—in the design of worm gear upon which its efficiency depends. Without digesting the problem the factors are very numerous; there are thus the diameters of the worm and the wheel and the gear ratio, also the velocity of rotation, and the torque or the horse-power transmitted (either may be specified). Beyond this there is the degree of approximate contact between the pressure surfaces, and there is the question of lubrication. The author's theoretical treatment is based definitely on the fact that the first group of variable factors, namely, the diameters of worm and wheel, the gear ratio, the revolution speed and torque transmitted, can all be represented from the point of view of efficiency in the one quantity, the pitch angle of the tooth and an assumed constant angle or coefficient of friction. For any set of gear between wide limits of load and speed, the angle of friction is in fact almost constant, quite near



FIG. 3a.

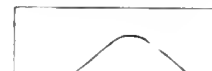

FIG. 3b.

enough so for the purposes of the foundation theory. On this assumption, (i.e., angle of friction = constant), it is then easy to demonstrate that the efficiency will be constant for all variations of torque and speed, also that the efficiency is independent of the diameters of the gears, provided that the pitch angle of the teeth is the same. The approximate truth of this as an experimentally established fact is the justification of the method, and this has been fully established by the National Physical Laboratory tests and report.

Comparative Test Data

In Fig. 1 is reproduced Fig. 42 from the previous paper, in which a comparison is given between one of the tests from the National Physical Laboratory report and one of the so-called tests of a parallel worm cited by Mr. Kerr-Thomas, namely, from a paper by Professor Kennerson. Here, at B, we see the National Physical Laboratory test of a Daimler-Lanchester worm in which from about 27 to 62 h.p., the efficiency does not vary more than one-third of 1 per cent., whereas in the plottings from Professor Kennerson's paper, at A, there is a curve which ranges from 35 to 65 h.p. over a variation of 8 per cent. Now in the results taken with the author's dynamometer, which is certified by the National Physical Laboratory to

*From paper read before the Institution of Automobile Engineers, December, 1916.

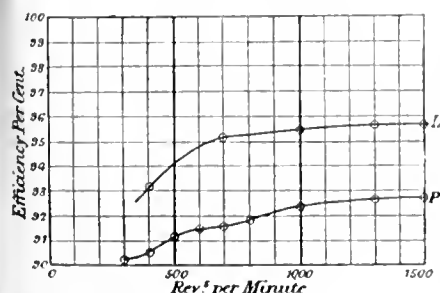

FIG. 2.

be true within one-fifth of 1 per cent. (1 in 500), and is probably ordinarily within 1 in 1,000, a considerable range of load was found in every case, over which the efficiency was virtually constant both in the Lanchester and parallel types and similarly the efficiency was also virtually con-

stant, it is actually the increase of the coefficient and falling off in the efficiency under excessive load that determines sharply the maximum load limit to which any given pair of gears may be subjected, for a very moderate increase in coefficient above its normal "least value" results in, or is evidence of, the

stated, and have seen that these are summed up in the one quantity, the pitch angle. It is clear that the assumption of a constant angle of friction simplifies matters to the utmost possible extent, for in place of the multitude of different variables we have only to consider the pitch angle of the tooth, that is, the angle relatively to the worm axis—all the quantities on which this angle depends are then accounted for. The efficiency is given by the simple graph as in Figs. 4 and 5.

The other half of the problem is to deal with the factors on which the constant or minimum coefficient of friction for any given pair of gears depends, and more broadly the factors on which the extent of the approximately constant range depends, for it is the extent of this range in direction of high loading which determines the maximum output capacity at any given speed of a pair of gears, and so determines their commercial value as an engineering asset.

Commercial Value of High Power Transmission

The commercial value of high power-transmission capacity from an automobile standpoint may be regarded as even greater than from an engineering standpoint, for the importance of weight-saving is paramount. Thus, if two sets of gears, one of 8-in. and another of 10-in. centres, were to possess the same horse-power capacity for a given revolution speed, and even (owing to a difference of design or material) were to cost the same, one might be justified in considering them equally favorably in any ordinary engineering problem, but if the 8-in. centre gears weigh proportionately less than the 10-in. centre set, they will be far more valuable and a more saleable article from the point of view of the automobile constructor and user.

The efficiency curve in any case is of the type represented in Fig. 3a. At very light loads the efficiency may be poor owing to the fact that oil is being churned in the gear and churned in the bearings, since the power so consumed is virtually independent of the load. On the other hand (as already pointed out), the efficiency curve falls at heavy load owing to the thinning and incipient breakdown of the lubricating film.

It has been regarded as open to ques-

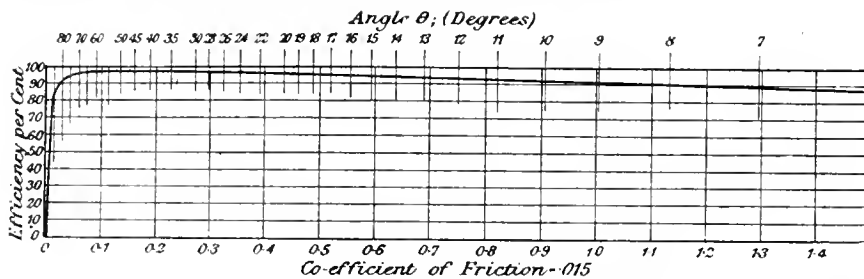

FIG. 4.

stant over a considerable range of speed, though here the variations were, perhaps, somewhat greater. The author showed that there is every reason to suspect the accuracy of Professor Kennerson's results, and at the outset the results of the National Physical Laboratory tests are taken as showing that this approximate constancy of the efficiency over a certain working range for any given set of worm gear is an established fact. The author's own tests (on his dynamometer) of worm gear of the parallel type show clearly the same characteristic feature, namely, the approximate constancy of the efficiency over a considerable range of velocity. Two typical curves are given in Fig. 2.

Falling-off in Efficiency

There are two conditions under which it would appear that the efficiency invariably shows a falling-off: Firstly, when the load per tooth for any given pair of gears exceeds a certain value; the other is when the tooth-rubbing velocity is less than a certain value; also there is, without question, a falling-off in the opposite extremes if a sufficiently great range of speed or load be investigated. Otherwise, the approximate constancy of the angle or coefficient of friction may be taken as established. It is evident that the constant condition corresponds to the minimum value of coefficient, or, conversely, the maximum of efficiency. In the nature of things, where A is a function of B, A is approximately constant in respect of B when A is a maximum and when A is a minimum. This is as commonly expressed on the equation for maximum or minimum value as $dA/dB=0$. Thus there is nothing extraordinary in the fact as stated. Its importance from the point of view of the theory of worm gear efficiency lies in the fact that the maximum is rarely, if ever, found to be a "peak," it is rather a "tableland," of the type shown in Fig. 3a, rather than the type shown in Fig. 3b.

It is a further point of importance in connection with the theory of worm gear that the practical range of usage over which efficiency is important does not carry us into the regions where the higher coefficients are met with. In-

partial breakdown or rupture of the lubrication film and the disintegration of the gear. This is the case, whether it be of the Lanchester or parallel type; in fact, the increase of the coefficient under heavy loading is the first sign of incipient lubrication failure, and so the point of fall in the efficiency curve under heavy loading may be taken as an invariable indication, in the comparison of any two pairs of gear, of their relative higher load limits.

In engineering practice we are accustomed to meet problems in which the coefficient of friction is legitimately treated as constant; in all these problems certain actual variations exist, but the underlying fact is so nearly true that the basic theory is correctly founded on the assumption of a constant coefficient of friction, and such changes as are met with are considered as variations from this constant value rather than in relation to the zero. The tests published in the author's previous paper fully establish the fact that power transmission worm gear comes legitimately into the group of such problems, though it was by no means certain prior to the paper that this was the case. If such results as those of Professor Kennerson were true, we should not be justified in basing any arguments on the constancy of the frictional coefficient, and the foundation of the theory of worm gear efficiency would consequently become far more complex and difficult than is actually the case.

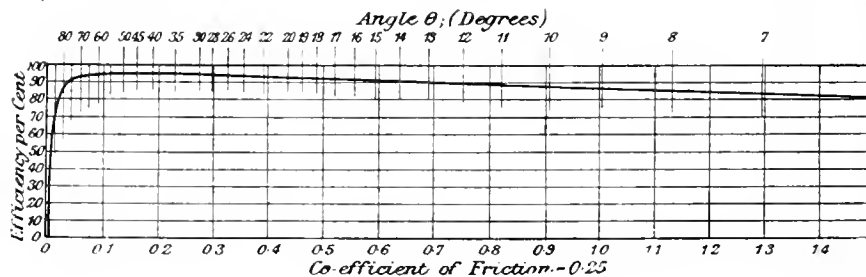

FIG. 5.

So far we have dealt with the group of factors which determine the efficiency as based on the coefficient of friction; in other words, we have confined our attention to the group of variable quantities which suffice to determine the efficiency once the angle of friction is

tion to what extent the magnitude of minimum coefficient (maximum efficiency) is controllable; the author has found evidence of considerable variation according to the type of gear and lubricant. If it were not controllable, then the maximum efficiency for every

individual pair of gears under the most favorable conditions would depend definitely upon the pitch angle of the tooth, and would be the same whether the gear is of the parallel or Lanchester type.

Tooth Surface and Load

It has also been regarded as an open question whether the breadth of the "tableland," if one may say so of the efficiency curve, can be increased. Thus it might be argued that if, by obtaining better proximate contact (by any means) the breaking-down of the lubrication could be persuaded to take place at a higher tooth load, this same greater proximity of the tooth surfaces may result in a higher viscous churning resistance, and so take off the range of coefficient at one end what it puts on at the other.

Although the author is prepared to take a liberal view and say that these points are open to controversy, opinion as based on present-day experience, is decidedly that a better type of tooth contact corresponds to an absolute lower minimum coefficient—probably due to a thickening of the oil film over the load-bearing area, and that this does not of necessity add to the churning loss.

The benefit of obtaining high tooth loads by improving the proximate contact of the tooth does not, however, depend intrinsically on an actual increase in the range. Even if what be gained at one end be lost at the other, the result of improving the proximate contact of the teeth (by whatever means accomplished) is to enable a given pair of gears to transmit a higher standard of loading. Conversely, for a given horse-power transmission, a smaller and lighter set of gears may be employed, with (a) a saving of money in material and machining, and (b) a saving of weight in the gears themselves and in the mounting, with a consequent better performance of the car, and, due to the reduction in the unsprung weight, less wear and tear on the tires, etc.

Automobile Application

We, therefore, realize that the essence of power transmission worm gear for automobile purposes is to be sought in achieving the highest tooth load compatible with the maintenance of the oil film and the approximate minimum coefficient of friction; any and every improvement in the area of proximate contact of the tooth surfaces in engagement with one another will be reflected in a bigger output from a given pair of gears and a reduction in the size and weight of gears for a given performance. It is one of the main objects of the present paper to examine the differences and relative merits of the Lanchester and parallel types of worm gear in this respect.

The advantage of reducing the centres and diminishing the size of a pair of gears for any given automobile is not only a matter of weight saving, important though this may be; it is equally a matter of compactness of design. It is and has been one of the difficulties in the

application of worm gear to the back axle that if the worm be arranged beneath the wheel the ground clearance is jeopardized, and if it be arranged above the wheel the body clearance has to be cut fine. The result of experience appears to show that for the home market the question of ground clearance is the less important; a full size touring car with 35 in. driving wheels and a worm gear of 6-in. centres can be designed to give an 8-in. clearance in the centre of the rear axle, and this has proved itself ample for use in the British Isles, where consequently the underneath worm is widely used.

Worm Location

It has been reported from Colonial sources that the worm underneath is objectionable as not providing sufficient clearance. The author is doubtful whether this objection is generally valid; the same objection once carried weight in commercial circles with regard to the home market. It seems incredible, with the wheel base now accepted, some 11 or 12 feet or more, that if a clearance of 12 in. is required under the axle, anything less than 18 in. or 20 in. can be sufficient under the body of the car. Apart from the mere question of actual clearance, a contact between the road or chance boulders and the flywheel or base of the engine is liable to prove far more serious than the contact of the comparatively robust housing of the worm gear. However this may be, the objection exists, and has been sufficiently strong to induce many of our constructors when adopting worm gear to place the worm above instead of below.

When the worm is placed above the axle the question of body clearance gives trouble. Now the fashion, at least for the home market, is to keep down the floor level as low as possible—a "pleasure" car with a high floor level and centre of gravity is to-day unsaleable, in the author's opinion rightly so. The result of this is that where cars have the worm placed above the axle it is often found necessary to gouge a piece out of the rear body and fit a casing which protrudes through the rear body floor in order to provide the necessary clearance.

Beyond the above, the cooling of the worm box with the worm on top is inferior to what it is when the worm is placed underneath; the actual importance of this point depends upon the general design of the car. There is thus every inducement, apart from the already important consideration of weight, to endeavor by all possible means to obtain the maximum horse-power or torque transmission capacity from a gear of any given size.



SHAFT TROUBLES

By John Elletthorn.

WHEN ammeter and voltmeter readings are taken on a line shaft and a heavy friction load is shown, it is usually stated by the investigator that the shaft is out of line and not leveled. In a recent

test, in a laundry plant, where the friction load registered 45 per cent. of full load, the expert stated that the shaft was out of line. The shaft was re-lined, and bearings repaired, at considerable cost in time and money. New readings were taken, but the friction load had increased to 52 per cent. of full load.

The engineer, who was just an ordinary fairly intelligent sample of the profession, directed the attention of the investigator to the fact that the pull of the countershaft belts was practically all at one side of the line shaft, and that the belts from the countershafts to the machines was perfectly vertical, which meant a very tight belt.

In re-lining the shaft the cross belts, which were very short in some cases, and therefore had a high belt tension, had their tension increased, which would account for the extra seven per cent. All the cross belts were removed from the line shaft and a test showed a friction load of 5 per cent. only, a decrease of 35 per cent. from the first readings.

In many cases when a belt begins to slip, the man in charge will cut out a piece of the belt, thus tightening it up and incidentally increasing the friction and stretching the life out of the belt. The intelligent use of a good belt dressing would often save considerable work and prolong the life of the belt for many months.

Many instruments are made to simplify the re-lining of shafts. Some are ingenious and useless and some are good if used intelligently and under proper conditions. If it is possible to have the power cut off from the shaft for a sufficient time to do the work, nothing can beat the lines, levels, plumb-bob, rule, and "gumption." I have seen men endeavoring to line a shaft while another shaft a few yards away and machines by the dozen were in full swing, causing such a vibration that no matter how tight the line was drawn, it would vibrate, while the "bubble" in the level would proceed to do a "tango" every time it was placed upon a hanger or bearing, and it was impossible to keep the plumb-bob from swinging. The use of one of the patented devices was no better. Therefore, do your line shaft lining when there is a shut down, Sunday, if no other day is available. If you shy at Sunday work, do it at night and sleep during the day. Of course, in some solidly built buildings the vibrations from one shaft to another would be next to nothing, but these later remarks refer to the other kind.

Make sure the fault is rightly located if the friction load is big. See that the hangers are not set too far apart for the diameter of the shaft and the load carried, that the diameter of the shaft is great enough to stand the pull at full load without springing, that the pull on the shaft, at the pulleys, is as close to the hangers as possible, that the pull is not all at one side of the line shaft, that as few belts as possible are vertical, and that the use of a good oil or grease is not forgotten.

EDITORIAL CORRESPONDENCE

Embracing the Further Discussion of Previously Published Articles, Inquiries for General Information, Observations and Suggestions—Your Co-operation is Invited

MACHINISTS' INSTRUCTION COURSE—XVIII.

By J. Davies.

A VERY useful tool for planer or shaper work is a number of small gauge blocks made to definite sizes. These blocks are used for setting the tool when a piece is to be planed to a number of different sizes. The gauge is placed upon the work and the tool set to just touch it, or to pinch a thin piece of paper placed upon it, as shown in the illustration, Fig. 67. This is a much

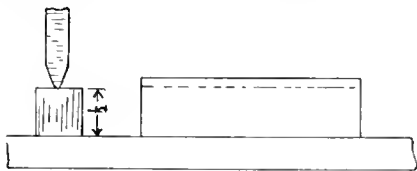

FIG. 67.

quicker and more accurate way than taking a trial cut and then measuring up the work.

Planing to Templet

If a large number of pieces are to be planed all to one size and form, particularly if it is a complicated form, after carefully planing the first piece, it should be bolted to the planer table and used as a gauge for setting the tool for others. If the piece is too large to be conveniently placed on the table behind another piece to be planed, as is the case in planing lathe or planer beds, etc., it would be necessary to make a special tool setting gauge for the job, which would be dependent on whether there was a sufficient number of pieces to be planed to make it worth while. See Fig. 68.

In cutting dove-tails or slots, one of the things to be contended with is the drag of the tool on the return stroke. If the dove-tail or undercut is not too great,

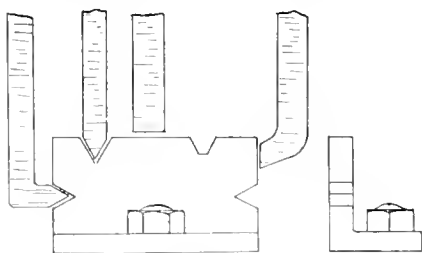

FIG. 68.

by swinging the top of the tool block away from the surface to be planed, the tool will clear itself on the return stroke, as it will lift away from the work, owing to the angle to which the tool block has been set over.

Planing Deep Slots

If cutting a very sharp angle or slot,

where there would not be room for the tool to lift away from the work, there are two alternatives, either to lengthen the stroke at each end of the job, so that the tool will run clear through the slot and can be lifted up at the end of the stroke clear of the slot and put down again at the other end, or the tool can be clamped rigidly in its place. In a certain machine shop recently the writer saw the simple device shown at Fig. 69, doing such work, and it seemed to give every satisfaction. A common door hinge was clamped to the back of the tool in such a way that it would bend on the forward stroke, and then, when the tool got past the end of the slot, the hinge would fall down, and on the return stroke it would lift the tool clear of the slot.

Tool holders are commonly used in most planer and shaper work. They are an advantage, not only from the great saving in tool steel, but from the facility with which the small inserted tool can be removed and ground up to shape. One special form of tool holder, peculiar to planers, is for holding three or four inserted roughing tools. These are called gang tools. It has been found that the resistance of a cut varies as the square of the thickness of the chip, and that a rougher feed can be taken if the cut is divided up among three or four tools than would be possible if only one tool was used. Owing to the fact that the cutting edge of planer tools are in advance of the point of support, there is a tendency for the tool to spring into the work, particularly when using a cutting-off or parting tool, as the tool is somewhat slender and springs more readily. This can be largely overcome by using a goose neck tool, bent in such a manner that the cutting edge will come behind the point of support and the pressure of the cut will cause the tool to spring away from the work, rather than into it (see Fig. 70).

Cast iron should be finished with a broad flat tool unless the metal is very hard and causes chattering when the breadth of the tool will have to be somewhat modified. In roughing out cast iron it is sometimes advisable to take a cut with a chisel along the edge, where the tool leaves the work, to prevent its breaking away and leaving ragged edge.

Milling Machine Work

The milling machine is one of the essential machines of the machine shop. It is capable of a greater variety of work than any other machine in the shop. They are built in a great variety of forms for special work, and are given names accordingly, but since the universal miller, with its attachments, can be used for every imaginable kind of a job within

the capacity of the machine, that is the one which shall receive principal consideration.

It would be almost impossible to enumerate every operation of which the universal milling machine with its attachments is capable, and it may be that different people would give the same operation different names. Following are a few of the names that are most commonly used in the workshop, also a few of the more general operations.

Plain milling consists in producing a

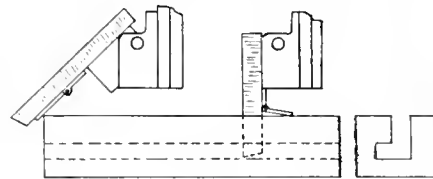

FIG. 69.

flat-finished surface, which can be done in three ways—either by feeding the work to the milling cutter in two horizontal directions—that is, lengthways or crossways, or straight up and down.

Form milling—that is the production of some complicated shape by the use of special formed cutters.

Gear-cutting, drilling, boring, reaming, angular milling, grooving, keyway-cutting, twist drill-making, end mill work, hobbing—that is the making of worm wheels by the use of hobs—slotting or sawing, and many others.

The first consideration in any kind of a milling job is naturally, how is it to be held? It may be secured directly to the table, held in a vise, bolted to an angle plate, held between centres, gripped in a chuck, carried on an arbor, bolted on parallels or V-blocks, or held in some special fixture or jig. However, it is held, it must be held rigid and care must be taken not to spring or distort the

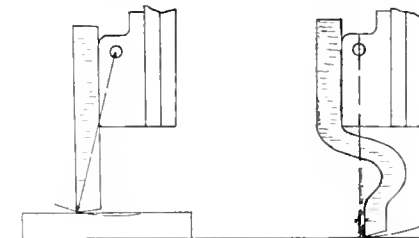

FIG. 70.

work in fastening it down. Generally speaking, the same kind of plates and bolts found around the drill and planer table are used; but greater care should be taken in setting up, as there is more strain on the job during a milling operation than there is in either shaping or planing.

THE MACHINE SHOP OIL CAN
By J. H. R.

THE ordinary oil can with which all machine shop men are more or less familiar, is in itself an apparently insignificant part of plant equipment, but its importance to maximum efficiency is very seldom given serious consideration. Every operator should be provided with his own particular oil can and should make it a point to see that it is not only used, but used in such a way that it assists him in his work and not as a means of creating trouble, preventing the proper working of the machine, as is often the case when care is not given to this serviceable but much abused article. No machine will run for any length of time unless properly lubricated, and by proper lubrication we do not mean an abundance of oil, but the application of the oil in such a manner that the highest factor of efficiency is obtained from its use.

While plenty of oil is one of the essentials of machine operation, it is very important that this oil should be entirely free from any injurious substance; and this latter feature is one of the things that is directly up to the man that uses the oil can. When it is necessary to put oil on any particular part of the machine or into any of the bearings, the first duty of the operator is to see that the oil can is entirely free from dirt or grit that might find its way onto the parts or into the different oil cups or chambers. When an oil can is not in use it should be kept in a place where the flying dust and grit from the various machines cannot get to it, as the very nature of the liquid is an attraction for foreign particles. Keep the exterior as dry and as free from oil as is possible, and never attempt to use the can unless you first, with a rag or piece of waste, remove any trace of grit from the spout. Many men will pick up an oil can and inject a supply of "oil" into a bearing without a thought as to where it has been lying for some time, with the result that considerable dirt may enter the oil cup along with the lubricating fluid. Immediately, results may not prove serious, but the foundation has been laid for the destruction of the bearing, which will eventually take place if this practice is continued.

Not so very long ago I noticed a young lad oiling his machine, the oil can he was using being of the kind where it is difficult to say whether the oil comes from the outside or the inside. In the course of his oiling procedure, the can slipped from his hand and fell beneath the machine into a pile of cast iron cuttings; he stoops down, picks up the can, and without wiping off the spout, continues to inject "oil" and other forms of evil, into the remaining oil holes. This is only one of many instances, of a similar nature that has come to my notice.

During the early stages of the shell activity, when unskilled labor was being profusely employed on the various machines, the want of experience in ma-

chine shop fundamentals, was one of the features that made it difficult for the different plant executives. In many cases machines would be operated under the most unsatisfactory conditions; partly through a lack of knowledge on the part of the man running the machine, and partly to his anxiety to make as much as he could by simply working his machine and not feeding it. I have seen operators using double the power to move the saddle of a lathe that would have been required if proper lubrication had been used on the ways of the lathe. Spindles and shafts have become seized through the neglect of the operator to provide sufficient oil in the bearings, or by allowing grit to enter the openings when putting in the oil. To overcome this objectionable feature in the operation of machinery under existing conditions, many plants have adopted the method of having a special oiler, whose duty it is to keep the various bearings on the different machines well oiled, and the openings covered from the atmosphere, thus almost eliminating the necessity of extra repairs. However, no matter what system is in vogue, it is highly desirable that greater attention be given to that small but highly essential accessory of the machine shop, the "insignificant oil can."

CUTTING UNDERSIZE THREADS WITH OVERSIZE DIES

By J. E. McCormack

CUTTING either a neat or an undersize thread with an oversize solid die may be accomplished in a simple manner by threading a piece of rod with the die and cutting it off a little longer than the thickness of the die. The piece is then filed or ground to fit snugly into one of the chip recesses in the die, keeping an untouched part of its threaded surface projecting into the work space. This plug should be filed or ground off a little at one end on the threaded face to correspond with the shape of the cut-

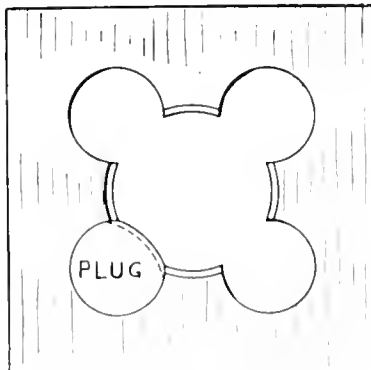

CUTTING UNDERSIZE THREADS WITH OVERSIZE DIES.

ting faces of the die. The work should first be threaded with the die alone, and then the plug used for obtaining the finished size. Thin strips of metal, cloth or paper may be inserted behind the plug if smaller size is wanted.

The same idea has been successfully applied to taps occasionally by fitting a plug in the groove of exact size taps to

make them cut big. It will work if the groove in the tap is sufficiently angular and with most taps it works alright until backing-out from a blind hole, when the piece rocks backward and acts like a ratchet dog. Where through holes are being tapped the piece can be put right down through and the trouble avoided.

PROTECTING BELT LACES FROM VERMIN

By J. E. McCormack

LAST summer the plant where the writer is employed was troubled with vermin which ate the leather lacing out of the rubber belts when machines were occasionally idle for a few days; even belts in regular use would sometimes have their lacing eaten during nights and Sundays. While experimenting

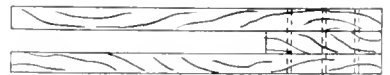
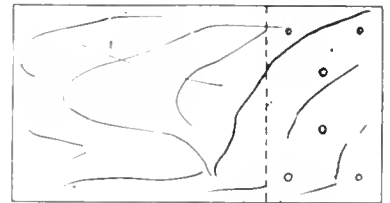

PROTECTING BELT LACES FROM VERMIN.

with various types of metal lacings to find one suitable for use on all of the belts, we protected the remaining leather lacings, when at rest, by placing over them shields made as per sketch, the dimensions varying with the size of the belt. The shields were made of 3 pieces of 1 in. board, nailed together and provided with a hole for a cord which was tied to the guard rail to prevent the shield from being carried to either pulley in case the belt was started up before the shield had been properly removed.

BUSINESS MAGNANIMITY

A CERTAIN big corporation, says the *Wall Street Journal*, was fortunate some years ago in getting a contract for a long period of years for raw material from a smaller corporation. It came to pass that prices of labor advanced sharply, so that the corporation which sold its raw material to its big client was making little or no money on its contract. Then the big corporation said: "you are not making any money out of the goods you sell, whereas we are making more money than we have ever made on our finished products. We'll do the square thing and pay you more than you are legally entitled to." This is the understanding of Wall Street interests. The big corporation referred to in court actions as merciless and contemptible is the United States Steel Corporation. The little brother benefited is the Pittsburgh Coal Company. Such things do not happen every day.

CONTEMPORARY WAR ARTICLES

Embracing Information and Data Drawn from a Variety of Sources Relative to and Arising from the Prosecution of this Many-Sided European War

THE GERMAN 42-CM. HOWITZER

THESE notes are the result of an accidental encounter with one of the 42-cm. howitzer batteries while on a visit of inspection to the 6th German Field Army, on the Arras section of the west front, between October 1 and 8, 1915. The battery was first met on the road at Henin-Lietard near Lens, on October 1, where the officer in charge explained the system of transportation. On October 5 the battery was again inspected by special permission, this time on the road near Pont Maudit, when the loaded wagons were uncovered and a number of the details explained. On October 8 the battery was inspected in a firing position near Estevelles, while bombarding Loos, which had been taken by the British on September 25, during the then recent great offence of the Allies.

Method of Transportation

The battery consists of two pieces. Each piece with its carriage and manœuvring appliances is transported on five steel-framed carriages with built-up riveted steel wheels. Each carriage is of a special design to suit its load. Each wagon is drawn by a motor tractor, to which it is close-coupled by a yoke and coupling pin. The whole battery, therefore, comprises 10 units, each unit being made up of a wagon and motor. In addition, four other ordinary motor trucks of 4 or 5 tons capacity accompany the battery, carrying small parts, supplies, etc. Owing to the size of the units, the battery takes up considerable road space and makes a formidable appearance. When inspected on the road, all wagons were covered with freshly-cut boughs, as a screen against aviators, and care was taken, when halted, to stop under the trees bordering Chaussee. The loaded wagons are normally covered closely with tarpaulins, so that nothing can be seen. The wagons of each piece are numbered and designated as follows:

No. 1 wagon—The appliance wagon, carries the material required in assembling the howitzer and carriage and for dismantling same. The principal item of the load is the four-legged gin and winch, with block and tackle. The legs of the gin are hollow steel spars fitted with couplings. The appliance wagon also carries heavy steel anchor pins, snatch blocks, and certain parts of the carriage, such as elevating and traversing gear, loading cranes, etc.

No. 2 wagon—The platform wagon, carries a one-piece steel-frame, U-shaped platform, with two box-girder steel rails for hauling the carriage into place on the platform.

No. 3 wagon—The cradle and spade platform wagon, carries the howitzer

cradle and a huge spade of special construction, to be described later.

No. 4 wagon—The carriage wagon, is the carriage proper of the piece, the hind wheels of the wagon constituting the carriage wheels as in a field gun, the front wheels of the wagon being used only for road transport and being uncoupled from the trail and replaced by the spade when the piece is mounted for firing.

No. 5 wagon—The howitzer wagon, carries the piece, which is supported in the grooved side rails of the wagon by projecting ribs on the side of the howitzer.

Motor Wagon

The motor wagons attached to No. 1 are larger and more powerful than the others, having motors of 60 to 80 h.p., and being provided with a steel-cable drum slung under the chassis. This drum is driven by the engine and is used for the purpose of hauling the different wagons on and off the platform. The motor wagons attached to wagons 2, 3, 4, and 5, have engines of 40 to 50 h.p., and are of different systems and manufacture, with the avowed intentions of trying out the different types of motor tractors under service conditions. Among the manufacturers noted are Daimler, Benz, Pedens and Pohl. All motor tractors are essentially of the same type as developed in Germany for agricultural purposes. They all have cleated rear wheels about 8 ft. in diameter, with tyres 12 to 14 in. broad.

In the Pohl system the rear wheels have, in addition to the cleats, a system of steel blades operated by an adjustable eccentric on the axle, and working through slits cut at right angles through the steel rim. By proper adjustment of the eccentric these steel blades can be set to project beyond the surface of the steel rim, and thus afford a better grip on the ground than is possible with the fixed cleats. This arrangement is similar to the feathering arrangement sometimes used on the paddle-wheels of steamers, and is stated to give increased adhesion, particularly on soft ground.

All engines on motor tractors are four-cylinder, water-cooled, with magnetic ignition, of simple but rugged construction. Transmission of power to the rear axle is by chain drive. Steering is effected through the medium of a quadrant and a chain, much the same as is used in heavy road rollers. One make of tractor had but one wheel on the front axle.

Assembling of the Piece and Carriage

For convenience in assembling the piece and carriage in the firing position, the various wagons of the battery are formed in column with the two No. 1 wagons at the head, followed by the two

No. 2 wagons, then the two No. 3 wagons, and so on. When traveling on metalled or hard roads, the wagons carrying parts of the carriage and the piece move on their ordinary wheels, which have smooth steel rims about 10 in. wide. When moving over soft ground such as when leaving the road to move into a firing position, caterpillar rims or girders are fastened to the front and rear wheels of the loaded wagons. These rims consist of 12 segments for the hind wheels, which are some 5 ft. 6 in. in diameter, and of eight segments for the front wheels, which are about 3 ft. 6 in. in diameter.

The position of the emplacements having been determined, and the caterpillar rims attached, the column is moved by the head to the designated position. Each No. 1 wagon moving to the emplacement of its piece is followed by the other wagons pertaining to that piece. No. 1 wagons are halted at the emplacements and, after erecting the gins and unloading their loads, are hauled aside. The motor tractors of the No. 1 wagons then take up their position a short distance to the front of the emplacement, from which point they can haul the remaining wagons up on to the platforms by means of the cable drums. If the ground does not admit of a straight-line pull, the tractors are located at any convenient point and the cable led around a snatch block to an anchorage.

No. 2 wagon is then hauled under the gin and the platform lifted clear by the gin, after which the wagon is hauled away and the platform lowered to the ground previously levelled for the purpose. When the ground is firm no other preparations than the levelling are required. When the ground is soft various expedients can be employed, either excavating to a firmer foundation, filling in with broken stone, or laying of a grillage of planks. The steel platform is lowered upon the prepared surface, carefully levelled, and oriented in the general direction of the fire.

No. 3 wagon is then hauled on to the platform, using the steel box-rails for this purpose, and the spade unloaded and temporarily laid on the ground. The cradle is then hoisted clear and the wagon hauled away, leaving the cradle suspended from the gin. No. 4 wagon is then hauled on to the platform, with caterpillar wheels attached, and approximately centred on the platform. The cradle is then lowered into the carriage, the cradle trunnions resting in the trunnion beds. The front wheels of No. 4 wagon are then uncoupled from the wagon and removed.

No. 5 wagon is then hauled up, its side rails being brought into line with grooves on the inside of the cradle, and

the howitzer pulled off, the machined ribs on the side of the barrel engaging in grooves in the cradle as they leave the grooved side rails of the wagon. The spade is then hauled into position and coupled to the trail of the carriage, the traversing and loading gears assembled, leaving the piece ready for firing. The battery commander stated that under favorable conditions the battery could be set up for firing in three hours.

The Spade

An interesting feature of the mount is the "sporn," or spade, which serves both to check recoil of the carriage and as a traversing rack for changing direction horizontally. It consists, essentially, of a huge segment of a circle of peculiar radial cross-section, being built up of steel plates and frames, measuring about 11 ft. on the chord. The radial cross-section measures about 5 ft. high and 6 ft. broad over all. The upper surface of the spade is in two levels, on the lower of which rests and slides the carriage-trail. In the vertical surface connecting the two upper levels lies a rack into which a pinion fastened to the trail engages. By operating the hand wheel on the pinion shaft, lateral motion is imparted to the trail. To the lower leg of the spade are bolted six blades, each approximately 2 ft. wide, which engage the ground and check the recoil of the carriage. If needed, a trench can be dug for the lower edge of the spade, and the back of the trench filled with broken stone and gravel well tramped into place to secure better resistance.

The Caterpillar Rim

The caterpillar rim consists of a double row of shoes, the outer shoes being about 22 in. wide by 26 in. long, and 2 in. thick, apparently of solid steel. The inner shoes are flanged so as to engage the wheel rim, and are hinged to the outer shoes at their middle. The slack of the girdle is such that at least two of the shoes lie flat on the ground, and but for a small sector of are three shoes are on the ground. The arrangement therefore insures that the weight of the wheels is always distributed to the ground through at least two outer shoes, resulting in such a distribution of weight as to enable the wagons to be hauled over soft ground. In this connection the battery commander stated that the motor tractors with caterpillar wheels could haul their loads over considerable obstacles, such as deep road ruts, shallow side ditches, low banks, etc.

The Howitzer

A more graceful and well-proportioned piece of ordnance could not well be imagined than the German 42-cm. gun. The bore between the lands measures exactly 42 cm., although the gun does not look so large. The thickness of the metal at the muzzle is surprisingly thin, not over 3½ ins. by estimation. The length of the gun over all is exactly 5 m., determined by measurement. The diameter of the breech is about 4 ft. The furniture is the well-known Krupp sliding block, and is completely opened or closed by three turns of the operating crank.

Personnel

The personnel of the battery consists of 280 men, commanded by a captain. Of the men, 200 are foot artillerymen and the remainder are chauffeurs and mechanics, most of them from the shops of the several motor truck manufacturers and from the Krupp works. An ordnance expert from the Krupp works was attached to the battery as a Lieutenant of the Reserves. In the actual firing of the battery, 25 artillerymen were required at each piece.

Ammunition and Ranges

The shell weighs about 820 kgs., or about 1,800 lbs. It is about 3½ or possibly 4 calibres long, and has the ordinary ogival head. The powder charge is contained in a large brass case about 18 in. high. The most effective range, namely the one giving the maximum accuracy, was stated to be 9,400 m. The maximum range is much greater, but no information would be given on this point. The ammunition is transported in a special motor truck column which was not encountered, and no details as to loads or number of wagons could be obtained.

Firing

On October 8, 1915, this battery was observed while firing on the British position at Loos, for which purpose it had been employed in a quarry pit pertaining to a cement mill near Estevelles. The floor of the pit is about 18 ft. below the general surface of the ground, and is entered by a ramp with a slope of about 1 in 8. The howitzers were set up close to the almost perpendicular bank of the pit, about 150 ft. apart. On each side of each piece was a shell and powder store, formed by a slight excavation in the bank and covered by paulins.

In loading, the pieces are brought to a horizontal position. A shell is brought from the shell store on planks laid on the ground and placed under the loading crane, from which is suspended a shell tray. The shell is rolled on the tray and clamped in place, a brass case with powder charge is set on the frame forming part of the tray, and the whole load hoisted by the crane, six men operating: the hoisting crank located near the end of the tray, three on each end. The tray is centred in the breech and the shell pushed into the chamber. The rammer staff, which is comparatively short, has knotted ropes fastened to its rear end; these ropes are led forward and, with some dozen men manning the staff, the projectile is rammed into its seat, giving forth the clear metal ring that indicates good centering. While ramming the men stand on the trail of the carriage and on the upper surface of the spade. The brass case containing the powder charge is then lifted from its frame and pushed into the powder chamber, after which the piece is elevated by the elevating crank in the front and traversed by the traversing gear in the trail. Sighting was, of course, indirect, the sighting point being a staff planted in the ground beyond the rear edge of

the pit. Firing was by lanyard, the man pulling it sometimes standing on the ground and sometimes remaining astride of one cheek of the carriage and taking a short hold on the lanyard.

The recoil of the gun is about 4 ft., and it moved back and forth easily without jar. Careful observation of the spade failed to disclose any visible motion. As the battery was fired at ranges from 7,600 to 7,800 m. (8,311 to 8,530 yards), the elevation was considerable, apparently about 40 deg. The high elevation, as well as the firm stony ground of the quarry, were both favorable to checking horizontal motion. It should be stated here that the cradle has two recoil cylinders and two return cylinders, one each above and below, and surprisingly small for so powerful piece of ordnance. A slight splinter-proof shield is also attached to the front of the carriage.

Fire control was from captive balloons and possibly also from a land station as it was stated that fire was being observed from three points. After each shot the results were telephoned to each gun, there being a telephone station between the guns. The blast effects were considerable, but not disagreeable to observers standing on the edge of the quarry pit in rear and about 80 ft. from the guns. The roof coverings of the buildings of the cement mill, located about 150 ft. in front, were lifted and dislodged. The battery fired seven shots in 29½ minutes by actual timing, counting from the first shot. There was not a single hitch or delay with either piece, although this was the first time the battery had been fired in the field, it being entirely new and fresh from the Krupp works at Essen.

Weights

The weights of the loaded wagons vary somewhat, but average about 15 tons. The motor tractors also vary, those of wagon No. 1 being the heaviest, and also weighing about 15 tons. On fairly good and level roads the battery travels about 10 km. per hour.—*Journal of the United States Artillery.*



Where His Brother Was.—A poor boy of wretched appearance, and apparently of about ten years of age, was recently brought before a Scotch magistrate charged with causing an obstruction by playing football in the street.

"Can your father not clothe you decently?" asked His Honor, surveying the bundle of rags with a look of profound disgust.

"Ma father's dead," replied the culprit sobbing bitterly.

"But you have some friends, surely?" persisted the Magistrate.

"I hae a brither."

"Where is he?"

"He's in the University Museum."

"Is he in a situation there?"

"Na, he's in a bottle there," was the unexpected reply. "He was born wi' tw'heids."

Observations on Safety Valves for Marine Boilers

By E. F. Maas

The various elements of marine boiler safety valves which have to do with successful operation are considered. Seven typical valves are discussed and illustrated. Many suggestions of practical value for the grinding and repair of safety valves are embodied, these being the result of observations made by the author on valves under working conditions, and on repaired valves in the laboratory. The subject is pertinent to our shipbuilding revival.

THE purpose of this article is not give a complete description of the design and working of all marine safety valves to be found on the market to-day, but to analyze some of the characteristics of the working parts of the more common types, to indicate their advantages and the difficulties experienced with them, and to point out helpful methods in repairing and improving old valves. The paper presents the results of observations made on valves under working conditions and during tests of repaired valves in the mechanical laboratory. In the case of one valve, not yet upon the market, the statements are based upon experience gained from work on other valves, and on a somewhat incomplete report of laboratory tests of this valve. This test was not witnessed by the author. Each of the seven figures gives, not a complete view of a valve, but a partial section only, this section showing such parts as come within the scope of the paper. It is assumed that the working of these safety valves is familiar to every reader, as well as the nomenclature of the valve parts. No general explanation of them, therefore, is given.

Fig. 1 represents a valve of a somewhat obsolete design probably not made by any manufacturer to-day. This type

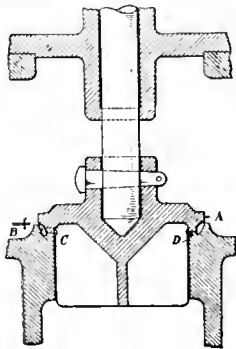

FIG. 1. OLD TYPE OF SAFETY VALVE.

is still to be found, nevertheless, in many of the older ships, and should be considered. Fig. 2 shows a later type of valve having an attachment for adjusting the blow-down, a feature indispensable in a modern marine safety valve. Fig. 3 is practically the same as Fig. 2, the main difference between the two being in the design of the blow-down adjustment. Fig. 4 represents one of the latest and most successful designs on the market at the present time. In

Fig. 5 is shown a valve which has not yet fully emerged from the experimental stage, and to the knowledge of the author is not yet offered for sale as a marine safety valve. Figs. 6 and 7 show modifications made to valves of

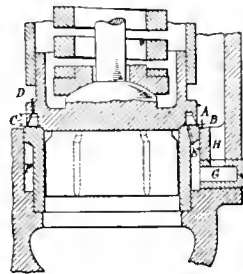

FIG. 2. LATER TYPE OF VALVE WITH ADJUSTABLE BLOW-DOWN.

the type represented by Fig. 3, these modifications having been applied during the repair of these valves in order to fit them for further service, after their original working adjustment had been destroyed through long service or neglect in maintenance. The particular features discussed in the article are:

(a)—Valve seat, flat or beveled, and its tightness.

(b)—Pop of valve, amount of simmering before pop, and height of lift.

(c)—Closure of valve and chattering at closure.

(d)—Blow-down of valve and methods of adjustment.

(e)—Discharge capacity.

(f)—Overhaul and adjustment of old valves and improvements made at slight expense.

Valve Seat

A glance at the figures will disclose two valves with flat seats (Figs. 1 and 5), the other five having beveled seats. While this might indicate that the beveled seat is the more common, the relative advantages of each type are strongly supported by manufacturers of the two types. The experience of the author has been that a flat seat is just as easy to grind-in and make tight as a beveled seat, and that the flat seat is more likely to stay tight. On account of the distortion of the valve seat which will result from a slightly uneven expansion or from spring of the material under high pressure, the tightness of a beveled seat is seriously affected, and the more so the greater the bevel, if by bevel we understand the angle between the valve seat and a plane perpendicular to the center line of the valve.

On the other hand, a flat seat will remain steam-tight even after a considerable distortion has taken place, provided that the valve has been carefully ground to its seat in the first place. It should be borne in mind that the valve and seat are in contact only along a very narrow strip, in the case of either flat or beveled seats. For equal lifts of the valves, a flat seat will give a greater discharge capacity under certain circumstances, as will be discussed later, a fact which will weigh in favor of the flat seat, for some designs, at least. It has been argued that a beveled seat, especially where the bevel is considerable, about 45 deg., will more easily rid itself of particles of scale or other foreign matter between the valve and its seat. In this connection attention should be called to the prevalent custom in marine practice of attempting to tighten the valve on its seat by turning it by means of the valve stem. Such practice usually has an effect directly opposite to that desired. A better way is to lift the valve from its seat by the easing gear and thus blow away the scale or other matter. A steeper bevel than 45 deg. is inadvisable for a steam safety valve, as the tendency for the valve to stick on its seat is too great and may produce disastrous results. It is significant that while only a few years ago most safety-valve specifications

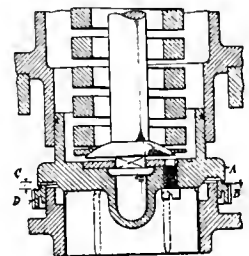

FIG. 3. MODERN SAFETY VALVE WITH ADJUSTABLE BLOW-DOWN.

called for seats beveled at an angle of 45 deg., specifications of to-day, notably those of the U. S. Navy Department and various State Boiler Rules, do not require it, indicating that a transition from 45 deg. to the flat seat seems to be under way. It is the author's opinion that such a change is for the better.

Pop of Valve

By "pop" of a safety valve is meant its instantaneous rise to almost full lift after the first tendency to move from its seat, or what is known as simmering,

*From a paper presented before the American Society of Mechanical Engineers, New York, December, 1916.

has taken place. A clean-cut pop is most vitally necessary in a successful safety valve. Without pop there will be a prolonged simmering of the valve as soon as the pressure has been reached for which the valve has been set, and the unduly prolonged simmering will soon score both valve and seat, particularly if the steam is superheated, thus producing a leaky valve. The pop of the valve in Fig. 1 will be determined by the diameter of the flange A, the amount of the distance B, and, to some extent, by the shape of the surface C. It is assumed, of course, that the valve has been ground to its seat and made tight. To design a valve of this type that will give a satisfactory pop, therefore, requires previous experience regarding the relations of these three variables, otherwise some experimenting must be done. When this valve is refaced and re-ground, it is also of utmost importance that the original conditions of the working parts be restored. Gauges for the original shape of both valve and seat, and the proper distance between the two, should be furnished the machinist repairing the valve, otherwise a misfit is liable to result and an uneconomical valve produced. A valve of this type requires a very long spring in order to give a satisfactory lift, on account of the small overhang of the flange A over the seating surface of the valve D, which limits the available additional lifting force required after the valve has started from its seat.

In the valve in Fig. 2, the pop will depend on the diameter of the flange A, the amount of the distance B, the depth C of the main pop chamber, and the size and number of the holes D. Of these four items, A and D are determined by the manufacturer of the valve, and, if rightly proportioned in the first place, need never be changed. Items B and C are both variable, however, with the wear and refacing of the valve and seat. In this valve it is desirable to have the lip A wear down in the same proportion as the valve and seat. As this is very seldom the case, however, there arises the necessity for adjusting these features when the valve is overhauled. It should be noted that the depth of the pop chamber does not influence the pop as much as does the distance between the flange lip and the valve bushing. The former need be checked only roughly, while the distance B must be absolutely correct. An approximate value for B is 0.01 in. for the average size of marine safety valve.

The pop in Figs. 3 and 6 is decided by the three items, size of flange A, distance B and depth of pop chamber C. In these respects the valves are similar to the valve of Fig. 2, the remarks about which will apply to Figs. 3 and 6. One difference, and an important one, is that the distance B can be adjusted after the valves are assembled, by means of the blow-down ring D. Thus, it would seem as if the necessity for the very close machining of the lip A in overhauling these valves would not exist. Such is not always the case, however, as the adjust-

ment of the distance B for a satisfactory pop may interfere with the adjustment for the desired blow-down. This will be explained in more detail later.

In the valves of Figs. 4 and 7, the pop is dependent upon the size of the flange A, the distance between flange and

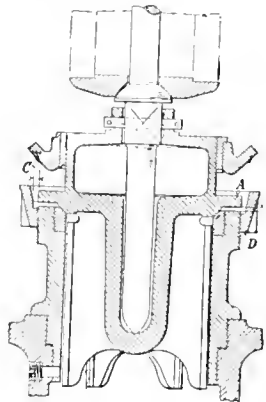

FIG. 4. RECENT TYPE OF MARINE SAFETY VALVE.

valve seat B, and the width of the ring-shaped opening at C. This difference between the two valves prevails, however, that in Fig 4 the main deciding feature is the distance B, by reason of holding the ring area C comparatively large, whereas, in Fig. 7, the pop will be determined mainly by the distance C, which is just large enough to let the valve flange A clear the inside of the adjusting ring D. Therefore, in overhauling the valve of Fig. 4, strict attention must be paid to the distance B in order to bring it back to its original value, by means of a cut from the wider side of flange A in case either the valve or its seat have been refaced, thereby lowering the valve and decreasing the distance B. In the valve of Fig. 7 only a rough check of distance B need be made. A suitable valve for this distance in an average-size valve is 3.16 in. The width of the ring area C has been fixed once in making the valve parts, and need never be changed in overhauling this valve.

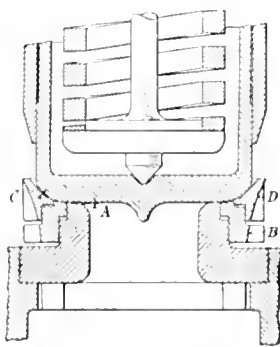

FIG. 5. EXPERIMENTAL VALVE.

In Fig. 5, the pop depends upon the distances A and C, which can be regulated by means of the adjusting rings B and D. The inner ring should be screwed very close to the valve disc, but not touching it. The outer ring furnishes the greater part of the additional

lifting force required after the valve has started from its seat.

Simmering

The reduction to a minimum of the period of simmering before lift, which is very essential to the successful working of any safety valve and to the length of its useful life, can easily be accomplished in all the valves of Figs. 3 to 7 if the proper care is exercised. In the valves of Figs. 1 and 2, as previously pointed out, the reduction of the simmering is mainly a question of design and original adjustment, unalterable after the valve has been set up.

Lift

It is known that all safety valves will give their highest lift at popping, the sustained lift being less than this by from 10 to 25 per cent.. The average lift of a 3-in. or 4-in. valve is about 1 1/2 in. To increase this lift without interfering with the blow-down or resorting to abnormally long springs is a difficult matter. In order to obtain the maximum lift, the valve spring should be made to contain as many turns as possible within the space available for it.

Closure

In order to prolong the life of a safety valve, it is necessary that its closure be accomplished with the minimum amount of shock. When a valve comes down on its seat each time with a heavy blow, both valve and seat will soon be distorted, and the valve will start to leak. For obtaining a large discharge capacity, a high lift is desirable, but this becomes a detriment if the closure is accompanied by shock. In this respect a valve with a beveled seat is generally inferior to the one with a flat seat, as the flat seat affords more of an opportunity for the steam to form a cushion at the moment of closure. Especially is this the case with the valve shown in Fig. 5, there being an excellent steam cushion between the valve disc and the inner ring B for checking the descent of the valve. Another valve which seems to give an easy closure, although having a 45-deg. beveled seat, is the one shown in Fig. 7. It is to be regretted that on neither of these valves are there available data on the length of their useful service without repairs upon which to base a more reliable conclusion regarding this feature of the valve closure. As previously mentioned, both of these are new types of valves and not yet fully tested out in service. The tendency of a valve to chatter at closure is generally caused by too small a blow-down.

Blow-down

For adjusting the blow-down, or difference in steam pressure under the valve at popping and at closure, there are two different systems represented in the valves shown. Before analyzing these two systems, it should be mentioned that in the valve of Fig. 1 there is no adjustment of the blow-down. In this valve, therefore, the amount of blow-down desired will have to be decided on in advance, by previous experience from similar valves, proportioning the

valve flange and the spring as well as the shapes of valve and seat so as to give the desired blow-down.

The arrangement in the valve of Fig. 2 for adjusting the blow-down is one probably familiar to most steam engineers. When this valve discharges, part of the steam passes through the holes E drilled in the bushing and into the chamber F, generally termed the secondary pop chamber, but more properly called the blow-down chamber. The only exit from this chamber is through the bushing G and the passage H communicating with the discharge space of the valve casing. By turning the bushing G and locking it in different positions, the size of this exit passage for the steam can be restricted, thereby limiting the amount of steam passing through the holes E, and so regulating the pressure under the valve lip A. Of course, the holes D in the valve flange will have a similar influence on the blow-down. The size and number of these holes are generally proportioned for a minimum blow-down of, say, 4 lbs. A smaller blow-down than this should not be attempted in any safety valve as it only shortens the life of the valve and produces a tendency to chattering, as previously mentioned, with no additional advantages in the working of the valve.

In all of the valves of Figs. 3 to 7, the adjustment of the blow-down is accomplished by means of the adjusting rings D. Screwing these rings up will increase the blow-down and screwing them down decreases it. The shapes of these rings should be noticed. The rings of Figs. 4 and 5 are especially adapted to give a minimum obstruction to the flow of steam and so increase the discharge capacity of the valve, both being excellent shapes. It has been especially claimed for the ring of Fig. 5 that in conjunction with the lower ring B it has the effect of reducing the lifting force at very low lifts and increasing it as the lift increases. This is a most desirable feature in any safety valve.

The ring D of Fig. 7 has been designed and tried out as an improvement on valves of the type shown in Figs. 3 and 6. It has already been pointed out that in these valves the main feature determining the pop is the distance B, also that the position of the ring D will determine the amount of the blow-down. Thus it will be seen that there are two factors to be considered in determining the proper position of these adjusting rings, and that each of these factors may require a different setting of the ring. In such a case it is necessary to take out the valve disc and machine its lip A until the proper distance of this lip over the adjusting ring is obtained, after first determining the position of the adjusting ring for the desired blow-down. This procedure involves tedious trials.

Where gauges for finishing the valve disc and adjusting ring are furnished by the manufacturer of the valve, it is comparatively easy matter to machine these parts when making repairs. When the time comes, however, to overhaul the

valve, it is generally found that all gauges are lost or unavailable. In order to eliminate the tedious machine work in overhauling and adjusting valves like those in Figs. 3 and 6, the modifications as shown in Fig. 7 were devised. The lip of the valve disc has

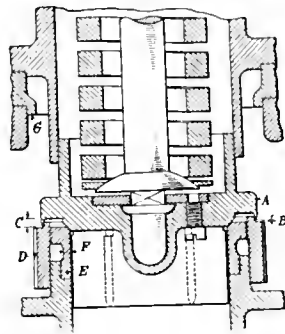

FIG. 6. MODIFIED SAFETY VALVE OF TYPE 3.

been cut away and the diameter of flange slightly reduced. The shape of the blow-down ring has been changed entirely, as shown, and made somewhat similar to the one in Fig. 4. The different action of the two rings D in Figs. 4 and 7 as regards popping has already been explained. The main feature in the ring of Fig. 7 determining the blow-down is the angle E. This angle, 36 deg., 30 min., has been found to give a range of blow-down of from 4 to 9 lbs. The laboratory tests on the popping and blow-down of this improved valve have given very good results.

Discharge Capacity

It is well known that when steam under pressure is allowed to flow through an opening, the maximum discharge will be obtained when the lower pressure is equal to or less than 58 per cent. of the higher pressure. When such conditions obtain, the pressure at the throat section, or most contracted part of the chan-

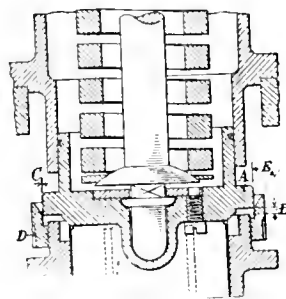

FIG. 7. ANOTHER MODIFIED VALVE OF TYPE 3.

nel through which the steam is flowing, will be 58 per cent. of the higher pressure, regardless of how much the pressure in the discharge chamber will fall below this value. The weight of steam discharged can then be calculated from Napier's formula: Flow in pounds per second = absolute pressure \times area in square inches \div 70. If this is applied to the safety valves shown in Figs. 1 to 7, it will be found that the valves of Figs. 1, 2, 4, 5, and 7 undoubtedly will

have their throat section at the inner circumference of the valve seat. Therefore, the area of opening at this section will determine the discharge capacity of the valve, provided the resistance to the flow is not made great enough to raise the pressure in the valve casing above 58 per cent. of the pressure under the valve seat. Making allowances for reductions of the free opening over the valve seat caused by guide wings, the following approximate formulæ, as given by some manufacturers, are obtained for calculating the discharge capacity:

$$W = 149 \text{ lpd for a flat seat}$$

$$W = 105 \text{ lpd. for a 45-deg. seat}$$

where W = discharge in pounds per hour
 l = lift of valve in inches
 p = absolute pressure under valve, lb. per sq. in.
 d = diameter of valve seat in inches.

For equal lifts, then, the flat seat will give a greater discharge than the 45-deg. seat, which is obvious when it is considered how the 45-deg. seat restricts the throat section of the valve as compared to the flat seat. It should be mentioned here that the discharge capacity will be influenced to some extent by the smoothness of the approach to the throat section. On this account, the valve of Fig. 5 should give an exceptionally good discharge capacity, which seems to be borne out by the meagre test figures available. With valves of the shape shown in Figs. 3 and 6, it is frequently found that the actual discharge capacity will fall considerably below that obtained by the above calculations. This, no doubt, can be accounted for by the throttling of the discharge channel under the valve lips, especially at the lower lifts.

Repair and Adjustment

Bearing in mind that a safety valve, to be successful and satisfactory, must not have too delicate an adjustment nor require too frequent overhauling, it seems advisable to alter the valve in Fig. 3 to the type shown in Fig. 7, where repeated attempts at obtaining satisfactory operation of the old type have failed. Such alteration can be accomplished easily and cheaply, as the only new part to be made is the adjusting ring D, and the only part to be machined is the valve disk. The result will be an exceptionally rugged valve having no delicate parts, and one which can be easily overhauled and adjusted without expert assistance.

Grinding

For grinding a valve to its seat the most satisfactory grinding material is powdered glass and machine oil. It is easiest and most expedient to grind a valve cold, and this will in most cases produce entirely satisfactory results. Only where repeated efforts at making a valve tight by these methods have failed, should hot grinding be attempted. The hot grinding is a trying performance to any workman, and will only be an approximation to actual working conditions in any event, as a grinding at the actual temperature under which a safety

valve operates is out of the question. Where all other methods have failed to produce a tight valve, the design shown in Fig. 6 will sometimes serve. By inserting the raised seat E and taking care to machine this so that its weakest section F will be between the old valve seat and the new, there is an opportunity for this raised seat to adjust itself to the valve, regardless of what expansions and contractions may be taking place in the metal of the old valve seat. Frequently this will produce a tight valve. The construction shown in Fig. 6 is an improvement on the valve shown in Fig. 3, but the same, or a similar design, can be applied equally well to most other types. In making this alteration to a valve it is necessary to have a new valve seat E and adjusting ring D, and to insert a distance piece G under the valve bonnet in order to raise the bonnet the same amount the valve has been raised from its former seat. The author has seen this method applied frequently and with great success.

Another point, often misunderstood in repairing a safety valve, is the amount of clearance to give to the guide wings under the valve disk in the valve bore. No attempt at a very close fit of these parts should be made, as such would only increase the chances of the valve sticking. A suitable clearance for a 4½-in. valve bore is 1-32 in. on the diameter, or 1-64 in. on each side.



HEATING BY STEAM AT DIFFERENT PRESSURES

RECENTLY in Chicago tests were made to determine the relative cost of heating with steam at atmospheric pressure as against 3 to 5 lb. pressure in modern office-building plants. In an analysis of the problem a heat requirement of 5,000 B.t.u. per hour was taken. On the whole, it appears that there is no appreciable difference in cost in heating at different pressures. There is, however, an advantage in higher pressure from the standpoint of first cost of plant, because as the pressure is greater the plant may be smaller. This factor, however, has a limited value in practice unless excessive pressures are used. As a matter of fact, any plant designed to work at 5 lbs. should have margin enough to work perfectly at atmosphere, and vice versa, so that in the end the cost of heating will be identical in both cases.



ADVANTAGES OF ECONOMIZERS

BOILER plant efficiency can be considerably increased by adding economizers, which are used in most European plants, but find little favor in this country. The objections ordinarily offered are:—Their initial cost; reduction of available draft and, in many plants, necessity of installing mechanical-draft systems; cheap fuel (speaking comparatively); low load factors; complication of the power-plant outlay.

The chief reason that they are not used more generally is that their value

is not realized. It is difficult to reason out just what effect load variations have upon an economizer as a heat absorber. If plants were operated continuously for 10 or 12 hours and completely shut down the rest of the time, the saving would be in proportion to the load factor, but where the load remains on, and only varies from overload to underload, the value is difficult to determine. Since however, such plants are ordinarily operated uneconomically at both high and low loads, and since economizers are of greater value the lower the boiler efficiency, they are particularly needed in plants having variable loads, and the saving in fuel, if not more, will be at least proportional to the load factor. Much depends upon properly proportioning the installation, and, therefore, before an economizer is decided upon, a plant must be closely studied and the governing factors, such as flue-gas temperature, feed-water temperature, weight of air per pound of coal, load factor, character of load, etc., very closely predetermined.



UTILIZING EXHAUST STEAM

THE value of exhaust steam for heating and the consequent saving effected has been demonstrated, and many plants take advantage of it, but the practice should be more general. Even plants operating condensing could bleed the low-pressure receiver of a compound engine or the low-pressure stages of steam turbines and distribute this steam through the buildings. In power plants where economizers are not employed and the temperature of the water is low when fed into the boilers, this partly expanded steam could also be used to advantage in feed-water heaters.

In plants where large quantities of low-pressure steam are required and the pressure cannot be expansively reduced in a cylinder or turbine, a saving still could be made by generating this steam in a boiler under low pressure. It has been experimentally determined that there is about 6 per cent. difference in boiler efficiency between generating steam at near atmospheric pressure and at 350 degs. Fah., because of the increased temperature difference between the furnace gas and the boiler water, greater heat absorption and consequently lower flue-gas temperatures.



REDUCIBLE LOSSES IN POWER PLANTS

THE greatest and most neglected loss in the average boiler plant is from excess air. The magnitude of this loss at different CO₂ percentages is applicable to any fuel, liquid, solid, or gaseous, if its available hydrogen percentage is known. The impression prevails that coal must be burned with about 50 per cent. of excess air. Some authorities claim that going beyond 10 to 12 per cent CO the loss due to incomplete combustion will offset the saving effected by reducing the excess air. This opinion is based upon certain types of in-

stallation only, and should not be accepted and disseminated as a general condition. Some few up-to-date plants are averaging 17 per cent. CO₂ with bituminous coal, without serious losses due to incomplete combustion.

One objection to high CO₂ is the extremely high furnace temperature and consequent rapid depreciation of furnace linings. For this reason many maintain 10 per cent. CO₂ as the maximum. With low percentages of excess air, proper design of combustion space becomes much more important to prevent incomplete combustion and too high furnace temperatures. Exceedingly high furnace temperatures have no real advantage and several disadvantages, therefore heating surface exposed directly to the fuel bed to reduce the furnace temperature will not only cause a decrease of the slagging effect upon the firebrick, and thus increase the CO₂ possible to maintain, but will also increase the efficiency of the boiler due to the heat radiated directly to it, and will increase the boiler capacity without increasing the flue-gas temperature. With a proper furnace volume, smoke will not form if provisions for gas mixing are maintained and the temperature does not drop off too low or the boiler is not forced too much. Velocity of gas, time of contact, and hydraulic mean depth are important and deserve thorough study under all conditions of installation. Not much is being done in this direction and quite large boiler builders ignore the matter altogether.

Boilers can be operated at two times their rating, and more, but not economically unless designed for it; with the rates of heat absorption obtained at present in most installations, if operated at very high ratings the loss will be too great, unless the temperature of the escaping gases be reduced in economizers. The increase of velocity will cause draft loss, but this is not so serious, for the necessity of installing mechanical draft brings other advantages. With high ratings and high velocities the power required to produce the draft becomes of interest. Fear that so much of the steam generated will be required to produce the draft that the advantages obtained will be offset is unfounded, if the blower is designed for efficient work and driven by an efficient engine or motor.



It is a bad practice to fasten zinc-iron sheets together with iron or steel rivets. These soon rust if not painted, and the rust penetrates through the edges of the iron encircling the rivets, and thus proves disastrous. Only zinc, or zinc-covered rivets, should be so used.

Zinc is ductile between 212 degs. Fah. and 302 degs. Fah., and can then be shaped as required; but when either above or below these limits it becomes brittle and unpliant, and, therefore, not adapted for treatment. It melts at about 786 degs. Fah., if volatilization is guarded against.

PROGRESS IN NEW EQUIPMENT

A Record of New and Improved Machinery and Accessories for the Machine, Pattern, Boiler and Blacksmith Shops, Planing Mill, Foundry and Power Plant

FLUID GAUGE FOR MEASURING WORK

MODERN requirements regarding the quick and accurate gauging or measuring of articles in course of manufacture have created a demand for a measuring device of an entirely different nature from micrometers and gauges. Despite the accuracy by gauges and micrometers, their liability to wear prevents them from remaining accurate for any great length of time under continuous use, in addition to which are errors due to the touch of the operator and degree of skill required.

The Prestwich Fluid Gauge has been developed as the result of long experience of these troubles, and by its articles can be very accurately and quickly gauged without skill or sense of touch on the part of the operator. It is not subject to wear, and with ordinary care will remain accurate indefinitely.

The instrument consists of a fluid-con-

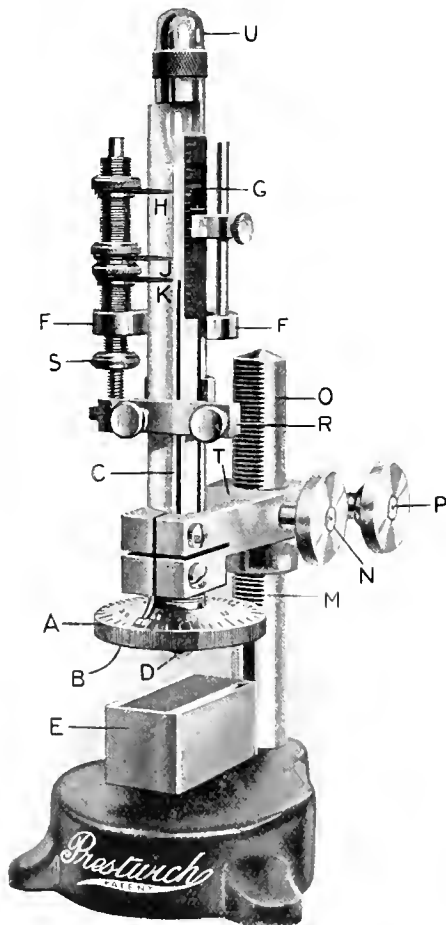

FLUID GAUGE FOR MEASURING WORK.

taining chamber "A," having a flexible diaphragm "B," a glass tube "C" of fine bore, which is connected with the chamber "A," means for indicating the dimensions of the piece, and means for

correcting for variations of temperature. The diaphragm "B" is provided with a hardened steel anvil "D." The article to be measured or gauged is passed between this anvil "D" and fixed anvil "E." Any pressure on the anvil "D" causes the fluid to rise in the glass tube "C." The chamber "A" is provided with a thread and micrometer index and pointer on the upper surface to indicate thousandths of an inch (or one-hundredths of a millimetre).

The carrier "F" is provided with a scale "G" and three adjustable pointers "H," "J," "K," the scale being divided to indicate ten-thousandths of an inch (or one-hundredths of a millimetre). The two top pointers "H," "J" indicate the tolerance limits it is desired to work to. The bottom pointer "K" is set to the normal level of the fluid in the glass tube "C." The carrier "F" is adjusted by the thumb nut "S" to keep the bottom pointer "K" level with the normal level of the fluid, and thus compensates for variations of temperature.

The instrument is roughly set by rack "M" and pinion "N" on the pillar "O" to suit the article, the clamping screw "P" then tightened up and the final adjustment made by the micrometer adjustment to a standard gauge or piece of known dimensions. A displacement of the diaphragm "B" causes a displacement of the level of the fluid in the tube "C" relative to their respective areas. Any variation in the size of pieces passed under the gauge is indicated by the difference in the height the level rises in the glass tube.

This apparatus is placed on the market by the Coats Machine Tool Co., New York.

CELL MOUNTING OIL CIRCUIT BREAKER

A COMPLETE line of oil circuit breakers has been recently developed by the Westinghouse Electric & Mfg. Co., East Pittsburgh, two of which, types E6 and E7, range in capacities from 300 to 1,200 amps, at 23,000 volts, and from 1,600 to 2,000 amps, at 16,500 volts. The former is for cell mounting, as illustrated in the accompanying engraving, while the latter is for wall or pipe mounting. All steel construction is used, thus providing apparatus which is exceptionally compact for its rupturing capacity, which ranges from 35,000 to 40,000 kva. at maximum rated voltage, with proportionately higher capacities for lower voltages.

For cell mounting, a novel feature is the holding of the steel base of each pole unit in channel irons built into the cell walls, whereby the units are easily slid in and out; the single pole solenoid complete with its mechanism, is mount-

ed on top of the cell structure. Accelerating springs are provided to break the arc as quickly as possible after the breaker starts to operate, an adjustable air cylinder dash pot being furnished to take up the shock of the moving parts.

All breakers are able to clear the system of a short-circuit up to its rated capacity three times without attention to circuits, a test of sixteen breaks he-



ing made on a 25,000 kva., 23,000 volt turbo-generator circuit, without the breaker being opened for change of arcs.

SHIP BAND SAW

THE revival of wooden shipbuilding has created a demand for numerous items of equipment possessing more or less novel features of construction, and the machine shown in the engraving herewith has been designed and built by J. A. Fay & Egan Co., Cincinnati, O., for the purpose of working the extra large timbers required in the construction of ocean going vessels.

This machine is designed for extra heavy band sawing, both straight and curved, and while particularly applicable to shipwork can also be used to advantage in railroad and bridge shops, heavy vehicle work, and lumber mills. It saws to any angle in a full semi-circle, the wheels being carried on a housing mounted on roller bearings and angling 45 deg. to right or left by power, with hand-wheel adjustment for extremely fine setting.

Column is a single casting of ample weight with broad floor bases which enable it to carry the wheels at any angle without vibration. An auxiliary column at the rear carries the angling mechanism, and the face of the main column is planed and fitted with roller bearings to carry saw carriages, guides, etc. The table measures 48 in. x 48 in. and is all iron, and mounted perfectly rigid on main column and always level.

The wheels are 48 in. dia. x 3 in. face, and carry blades up to 3½ in. wide. They are steel spoked with laminated

wood rims, faced with rubber, and are mounted in self-aligning ball bearings. Both wheels are mounted on a heavy circular carriage, gibbed to the main frame and traveling on self-lubricating roller bearings mounted in main column, making angling adjustment quick, easy and extremely close. The wheels move simultaneously, and are so located in relation to the carriage that the blade angles from the point where it passes through the table.

Driving gear is provided with automatic take-up to maintain proper tension on belt at any angle. A 15 horse-power motor at 1,500 to 1,800 rev. per min. can be belted to main driving pulley, or if at 350 rev. per min. can be direct coupled to drive shaft.

14 IN. TOOL ROOM LATHE

THE machine shown in the accompanying engraving is the most recent design of tool room lathe placed on the market by the Cincinnati Iron & Steel Co., Cincinnati. These lathes which bear the trade name of Cisco are of 14 in. capacity and of the four-step cone pulley type with back gearing. The machine as illustrated is equipped with lubricating pump, pan, taper attachment, and relieving attachment in addition to regular equipment. The pump is mounted on a bracket fastened to the cross web of leg casting under headstock, and is driven by belt from a pulley on the

tail end of the lathe spindle. The relieving attachment is gear driven from the spindle, with sliding drive shaft

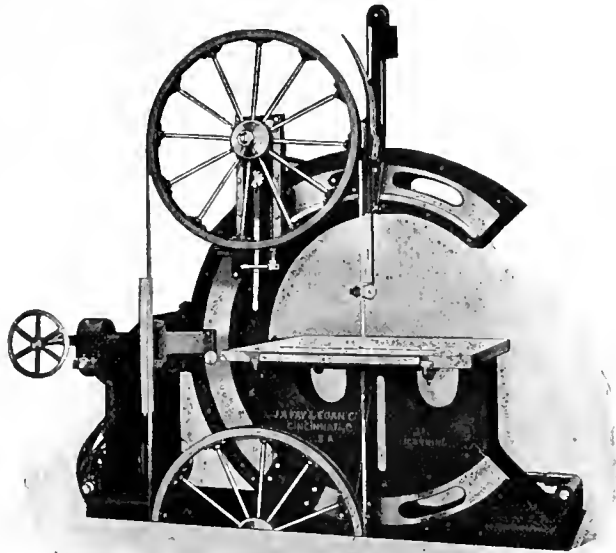

BAND SAW WITH ANGULAR ADJUSTMENT FOR CUTTING SHIPS TIMBER.

placed along the front of headstock. A bracket on the side of carriage supports the end of the shaft so that the jointed section next to the compound rest may function properly, one of the universal joints being of the telescopic type so that angular adjustment of the compound rest may be made at any time.

Automatic stop, thread stop and tool tray are regularly fitted to these lathes, the stops being operated by stop lock at bottom of apron. A quick change feed box is incorporated in the design. Draw-in collet chuck is supplied when specified, while face-plate steady rest, back rest and necessary change gears are supplied as illustrated.

COMBUSTION IN HAND-FIRED FURNACES

THE fuel in most types of furnaces acts primarily as a gas producer. With a 6-inch fuel bed the oxygen in the air rising through the grate is all used up in combustion in the first 4 inches from the grate. At a distance of 4 inches from the grate the carbon dioxide content of the gases has reached or passed a maximum of 10 to 16 per cent. and begins to drop. At the surface of the fuel bed the gases contain no oxygen, only 6 to 8 per cent. of carbon dioxide and 20 to 32 per cent. of combustible gases. The composition of the gases is practically independent of the rate of air supply. The larger the quantity of air forced through the fuel bed, the faster the fuel burns or gasifies, but the ratio between weight of air supplied and weight of fuel burned remains constant at about 7 to 1. In general the temperature in the fuel bed is the highest at 3 to 5 inches from the grate, which is also the point of maximum carbon dioxide content.

Fuel Bed Thickness

As most of the oxygen is consumed in the first 4 inches of the fuel bed, it is not necessary with the ordinary rates of combustion to run a fuel bed thicker than 4 to 6 inches in order to obtain a high carbon dioxide and a low oxygen content in the flue gases. The rate of combustion or gasification of coal depends on the amount of air that can be passed through the fuel bed. The thicker the fuel bed the higher is its resistance to flow of air through it and the less air can be passed through with a given chimney draft. A thick fuel bed, therefore, reduces the rate of combustion and thus reduces the capacity of the boiler.

A thick fuel bed is further undesirable because it increases the tendency of the coal to form troublesome clinker. Perhaps the only apparently defensible excuse for carrying a thick fuel bed is the fact that the chances of burning holes in the fuel bed are reduced. A skillful fireman avoids holes in the fuel bed by firing frequently and placing coal on the thin spots. A claim that fuel beds can not be kept in good condition if carried thin is a confession of neglect and lack of skill. A fuel bed is understood to be only the layer of incandescent and freshly fired fuel and does not include the layer of dead ashes and clinker on the grate. The ash fuses in the upper layers of the fuel bed, and as it sinks it solidifies 2 to 4 inches from the grate.

As at the surface of the fuel bed the gases contain 20 to 32 per cent. combustible gas and practically no free oxygen, to obtain complete combustion additional air must be introduced over the fuel bed. This statement is true of all the fuels, including coke, tested by the Bureau of Mines, Washington, D.C. As a general statement, about one-half of the 15 pounds of air used to burn 1 pound of coal in a boiler furnace is supplied through the fuel bed; the other half must be supplied over the fuel bed.

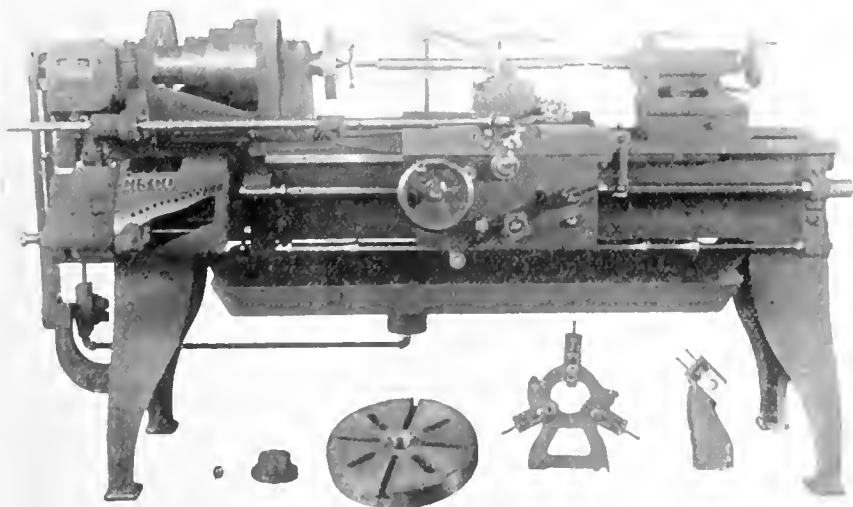

14-INCH TOOL ROOM LATHE.

The MacLean Publishing Company

LIMITED

(ESTABLISHED 1888)

JOHN BAYNE MACLEAN - - - - - President
H. T. HUNTER - - - - - Vice-President
H. V. TYRRELL - - - - - General Manager

PUBLISHERS OF

CANADIAN MACHINERY AND MANUFACTURING NEWS

A weekly newspaper devoted to the machinery and manufacturing interests.

PETER BAIN, M.E., Editor. B. G. NEWTON, Manager.

Associate Editors.

A. G. WEBSTER, J. M. WILSON, J. H. RODGERS.

Office of Publication. 143-153 University Avenue, Toronto, Ont.

Vol. XVII.

APRIL 19, 1917

No 16.

OUR SHELL INDUSTRY EBBING

NOTWITHSTANDING the fact that the munitions industry in Canada has long ago outstripped in scope and proportions the most substantial of those to which we pinned our faith in pre-war days, it has never been believed but that a modicum—if even that much, of the activity now in progress would retain a permanent value. The various plants created by our own and the Imperial Governments will doubtless be permanently preserved on a production footing, the extent of which will be largely governed by the status of the peace arrangements, the definiteness of the security against an early or late future repetition of this three-year tragedy, and the decision to maintain, or otherwise, the condition of preparedness now so well and fully established.

Although, generally speaking, the end of Canada's munition industry is by no means in sight, evidences are not wanting that some considerable curtailment of shell-making activities may be said to be at least imminent if not already operative. Attention has been drawn in these columns on several occasions during the past year or more to the extraordinary degree of development output being procured from Britain's specially created and equipped National shell factories, as also to the possibilities that, in spite of the necessary prodigal expenditure of shell in bending "Hindy's" line at least back to the Rhine before the snow flies in the coming winter, the bulk of the Allied requirements would be met within the Motherland borders. Such a consummation has, we believe, now been achieved, and, as a consequence, further or repeat orders for 8 in. and 9.2 in. high explosive shell are likely to be restricted in both number and quantity. We understand that the 60-pdr. projectile, a small number of which, comparatively speaking, have been produced here, is also likely to be eliminated.

It must be admitted, however, notwithstanding our awakeness to the fact of shell making being a transient and temporary industry, that even the beginnings of parting with it as above indicated may for the time being disturb the even tenor of our metal-working plants routine here and there. On the other hand we have much cause for

thankful appreciation of the progress being made by our men in the field, besides having the consciousness that they are equipped and to spare, and that maintenance in both respects is assured right close to their spheres of action.

Another phase of the situation, and by no means an unimportant one, is that of the relief for the carrying of food supplies, of ships, otherwise engaged in transporting big shells across the Atlantic with its swarming dangers from enemy submarines and mines. It should be a source of much satisfaction to us, rather than otherwise, bearing in mind our gigantic vessel losses, and the acuteness of the food situation in the Motherland arising therefrom, that the efforts of her munitions-making army, the larger proportion of which is female-constituted, have, to even the extent indicated, relieved a growing menace to our Empire health and war activities. We in Canada have not as yet felt the pinch of lack of food, although in other respects we have profited as well as lost along with the people of Britain, and, in the apparently gradual ebbing away now of orders for the bigger shells, we may possibly still have an advantage in the readjustment following the Peace Declaration. No let-up is in sight so far as we can gather, with respect to continued activity in the other sizes and type of shell, to the generous output of which the great bulk of our metal-working plants are still contributing, and of whose individual features it is unnecessary to make a detailed reference here.



THE SHIPBUILDING SITUATION

A GOOD deal of enthusiasm has been aroused not only among interests closely related to the twin crafts of shipbuilding and marine engineering, but among those more or less indirectly concerned, because of the fact that in both these spheres of industrial endeavor, our plant capacities are more or less taxed with orders—in a word, there is quite a little boom on. The foregoing is true of both wood and steel construction, although the latter easily predominates. Some misconception is, however, abroad as to the direction of effort and scope of the meantime activity. Aside from a little vessel construction to the order of private individuals or shipping corporations, both the British and Canadian Governments through their accredited representatives—the Imperial Munitions Board on the one hand and J. W. Norcross, vice-president and managing director of the Canada Steamship Lines, on the other—have placed various contracts, the former for ocean-going freighters and the latter for a type of craft whose service will be more or less confined to ocean coastal waters.

As regards the coasting vessels, quite a fleet has been ordered, and in view of the circumstance that completion and delivery of all are required within some six months' time, it may perhaps be unnecessary to state that hulls and machinery are well advanced in construction in not a few instances. Delivery on the ocean-going freighters, orders for which have for the most part already been placed, is called for by mid-Autumn, 1918.

We had hoped that some definite action towards the production of ship and boiler plate would have been taken by one or other of our large steel interests ere this, but notwithstanding rumors to that effect, no move has been made in the direction indicated; as a matter of fact we are apparently further away than ever from being in a position to meet, at least, our own needs in ship and boiler plate, and that in normal circumstances. Shipbuilding within our borders to be robust must, of course, be subsidized in some form or other, and until some steps are taken to so encourage it, the plate mill essential is likely to remain a dream.

INDUSTRIAL NOTABILITIES

COLONEL DAVID CARNEGIE, member Imperial Munitions Board and ordnance advisor, Ottawa, Canada; consulting technical ordnance advisor to Department of Militia and Defence, Canada, was born at Aberdeen, Scotland, 1868, son of David and Margaret Carnegie, of Aberdeen, and received his education at Gordon's College, Aberdeen, and Royal College of Science and Royal School of Mines, London, England. On the completion of his apprenticeship to mechanical engineering at Aberdeen, 1887, he engaged in the manufacture of torpedoes, Royal Arsenal, Woolwich, 1887-89, and was science master, evening classes, Science and Art Department, London, 1889-91. From 1890-1902 Colonel Carnegie was in charge of projectile manufacture at Woolwich Arsenal, following which he was work's manager, Hadfield's Steel Foundry Co., Sheffield, 1902-6; consulting engineer and general manager, Samuel Osborn & Co., Sheffield, 1906-10; entered private practice as consulting engineer, London, 1911; director, Electric Steel & Metals Co., Welland, Ont., 1913, resigned, 1914.

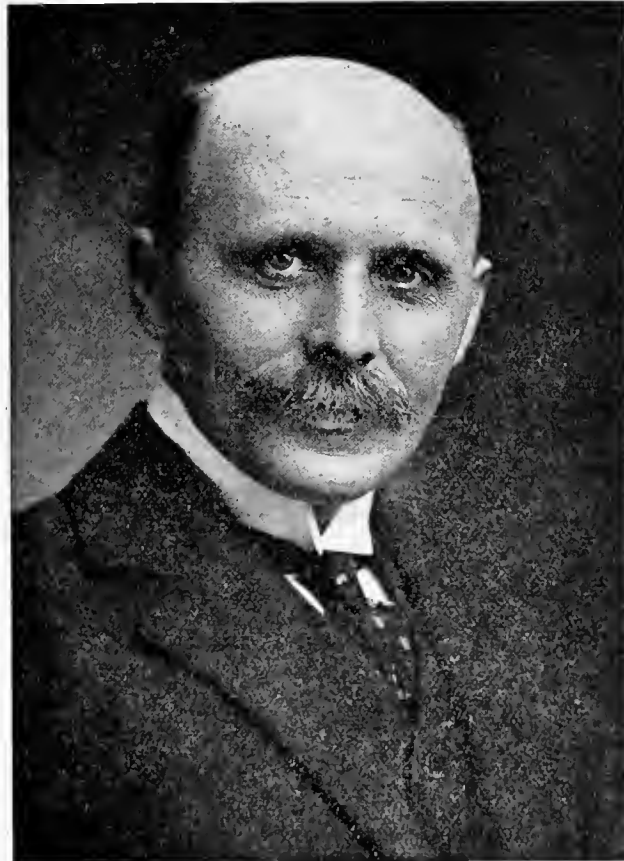

COLONEL DAVID CARNEGIE.

During 1915, Colonel Carnegie was a member of Commission of Armaments Manufacture in Canada; and was also chairman of Commission on Copper and Zinc. He became a member of Institute Mechanical Engineers, 1893; Iron & Steel Institute, 1903; student, Institute Civil Engineers, 1890, associate member 1893, member, 1906; fellow, Royal Society, Edinburgh, 1910.

Published works include, "Liquid Steel, its Cost and Manufacture," Longman's Co., 1913; "Manufacture of Forged Steel Projectiles," 1891; "Manufacture and Efficiency of Armour Plate," 1892; "Manufacture and Efficiency of Armour Piercing Projectiles," 1903; "Results of Investigation on Manufacture of Steel in Belgium," 1910; "Report of Commission on Copper and Zinc, Canada," 1916. Colonel Carnegie has also secured several patents for manufacturing processes and designs which are now in use in different parts of the world.

In February, 1915, he was gazetted Hon. Lieut.-Colonel, Militia, Canada, being gazetted Hon. Colonel, May, 1916.

Colonel Carnegie married Frances Ellen Lloyd, daughter of Thomas Howard Lloyd, and has three sons. His club is the Rideau (Ottawa); his religion, Presbyterian; and his residences are London, Eng., and Chateau Laurier, Ottawa, Canada.

Photo courtesy International Press.

SELECTED MARKET QUOTATIONS

Being a record of prices current on raw and finished material entering into the manufacture of mechanical and general engineering products.

PIG IRON.

Grey forge, Pittsburgh	..\$37 95
Lake Superior, charcoal, Chicago	.. 38 75
Standard low phos., Philadelphia	.. 75 00
Bessemer, Pittsburgh	.. 42 95
Basic, Valley furnace	.. 40 00
Montreal Toronto	
Middlesboro, No. 3
Cleveland, No. 3
Clarence, No. 3
Hamilton
Victoria

FINISHED IRON AND STEEL.

Per lb. to Large Buyers	Cents
Iron bars, base, Toronto	.. 4 25
Steel bars, base, Toronto	.. 4 50
Steel bars, 2 in. to 4 in. base	.. 6 00
Steel bars, 4 in. and larger base	.. 7 00
Iron bars, base, Montreal	.. 4 25
Steel bars, base, Montreal	.. 4 50
Reinforcing bars, base	.. 4 05
Bessemer rails, heavy, at mill	.. 38 00
Steel bars, Pittsburgh	.. 3 75
Tank plates, Pittsburgh	.. 5 75
Beams and angles, Pittsburgh	.. 3 40
Steel hoops, Pittsburgh	.. 4 00
F.O.B. Toronto Warehouse.	
Steel bars, base	.. 4 50
Small shapes	.. 5 00
F.O.B. Chicago Warehouse	
Steel bars	.. 4 25
Bars, 2 in. and up	.. 4 40
Structural shapes	.. 4 50
Plates	.. 6 00

FREIGHT RATES.

Pittsburgh to Following Points	Per 100 lbs.
	C.L. L.C.L.
Montreal	.. 23.1 31.5
St. John, N.B.	.. 35.1 45.5
Halifax	.. 35.1 45.5
Toronto	.. 18.9 22.1
Guelph	.. 18.9 22.1
London	.. 18.9 22.1
Windsor	.. 18.9 22.1
Winnipeg	.. 64.9 85.1

METALS.

	Montreal	Toronto
Lake copper	..\$38 00	\$40 00
Electro copper	.. 38 00	40 00
Castings, copper	.. 37 00	39 00
Tin	.. 55 00	56 00
Spelter	.. 14 00	13 00
Lead	.. 12 50	12 25
Antimony	.. 28 00	36 00
Aluminum	.. 70 00	68 00

Prices per 100 lbs.

PLATES.

	Montreal	Toronto
Plates, 1/4 to 1/2	..\$7 50	\$7 50
Heads	.. 7 60	7 60
Tank plates, 3-16 in.	.. 7 50	7 50

WROUGHT PIPE.

In effect April 10, 1917.

Per 100 feet—	Black	Galv.
	Buttweld.	
1/4 in.	..\$ 4 50	\$ 6 00
1/2 in.	.. 4 32	6 36
3/4 in.	.. 4 32	6 36
1 in.	.. 5 61	7 18
1 1/4 in.	.. 7 02	9 14
1 1/2 in.	.. 10 37	13 52
1 3/4 in.	.. 14 03	18 29
2 in.	.. 16 78	21 86
2 1/2 in.	.. 22 57	29 42
3 in.	.. 36 27	47 00
3 1/2 in.	.. 47 43	61 58
4 in.	.. 58 88	75 90
4 1/2 in.	.. 69 76	89 93
Lapweld.		
2 in.	.. 25 53	32 01
2 1/2 in.	.. 38 03	48 26
3 in.	.. 49 73	62 18

3 1/2 in.	.. 60 72	78 66
4 in.	.. 71 94	93 20
4 1/2 in.	.. 83 82	108 60
5 in.	.. 97 68	126 50
6 in.	.. 126 70	164 50
7 in.	.. 166 60	213 00
8 L. in.	.. 175 00	223 80
8 in.	.. 201 60	257 80
9 in.	.. 241 50	308 80
10 L. in.	.. 224 00	286 40
10 in.	.. 288 40	368 70

Prices—Ontario, Quebec and Maritime Provinces.

WROUGHT NIPPLES.

4" and under, 60%.	
4 1/2" and larger, 55%.	
4" and under, running thread, 40%.	
Standard couplings, 4" and under, 50%.	
4 1/2" and larger, 30%.	

OLD MATERIAL.

Dealers' Buying prices.

	Montreal	Toronto
Copper, light	..\$22 00	\$23 50
Copper, crucible	.. 26 50	28 00
Copper, heavy	.. 26 50	27 50
Copper wire	.. 26 50	28 00
No. 1 machine composition	.. 22 50	23 00
New Brass clipplings	.. 18 00	18 00
No. 1 brass turnings	.. 16 00	17 00
Heavy Melting steel	.. 19 00	16 00
Steel turnings	.. 12 00	9 00
Boiler plate	.. 18 50	10 50
Rails	.. 19 00	15 00
Axles, wrought iron	.. 22 00	24 00
Rails	.. 17 00	18 00
No. 1 machine cast iron	.. 21 00	20 00
Malleable scrap	.. 15 00	11 00
Pipe, wrought	.. 12 50	9 00
Heavy lead	.. 9 00	10 00
Tea lead	.. 7 50	6 50
Scrap zinc	.. 9 00	10 00
Aluminum	.. 36 00	35 00

BOLTS, NUTS AND SCREWS.

	Per Cent.
Coach and lag screws	.. 30
Stove bolts	.. 55
Plate washers	.. 10
Machine bolts, 7-16 and over	.. 10
Machine bolts, 3/8 and less.	.. 20
Blank bolts	.. 10
Bolt ends	.. 10
Machine screws, fl. and rd. hd., steel	.. 27 1/2
Machine screws, o. and fil. hd., steel	.. 10
Machine screws, fl. and rd. hd., brass	.. add 20
Machine screws, o. and fil. hd., brass	.. add 25
Nuts, square, up to 1 in., net list.	
Nuts, hex., up to 1 in., net list.	
Copper rivets and burrs, list plus	.. 30
Burrs only list plus	.. 50
Iron rivets and burrs	.. 27 1/2
Boiler rivets, base 3/4-in. and larger	.. \$6.65
Structural rivets, as above	.. 6.55
Wood screws, flat, bright	.. 72 1/2
Wood screws, O. & R., bright	.. 67 1/2
Wood screws, flat, brass	.. 37 1/2
Wood screws, O. & R., brass	.. 32 1/2
Wood screws, flat, bronze	.. 27 1/2
Wood screws, O. & R., bronze	.. 25

MILLED PRODUCTS.

	Per cent.
Set screws	.. 35
Sq. & Hex. Head Cap Screws	.. 30
Rd. & Fil Head Cap Screws	.. 10
Flat 7/8 But. Hd. Cap Screws plus	.. 10
Fin. & Semi-fin. nuts up to 1 in.	.. 25
Fin. and semi-fin. nuts, over 1 in., up to 1 1/2 in.	.. 30
Fin. and semi-fin. nuts, over 1 1/2 in., up to 2 in.	.. 20
Studs	.. 10
Taper pins	.. 40
Coupling bolts, plus	.. 10
Planer head bolts, without fillet	.. 10
Planer head bolts, with fillet	.. 10 and 10
Planer head bolt nuts, same as finished nuts.	
Planer bolt washers	.. not
Hollow set screws	.. list plus 20
Collar screws	.. list plus 30, 10
Thumb screws	.. 20
Thumb nuts	.. 65
Pathe bolts	.. add 40, 10
Cold pressed nuts to 1 1/2 in.	.. add \$4.50
Cold pressed nuts over 1 1/2 in.	.. add \$7.00

BILLETS.

	Per gross ton
Bessemer billets	.. \$75 00
Open-hearth billets	.. 75 00
O.H. sheet bars	.. 77 50
Forging billets	.. 100 00
Wire rods	.. 85 00

F.o.b. Pittsburgh.

NAILS AND SPIKES.

Wire nails	.. 5 00	4 95
Cut nails	.. 5 00	5 00
Miscellaneous wire nails	.. 60%	
Pressed spikes, 5/8 diam., 100 lbs.	.. 5 20	

MISCELLANEOUS.

Solder, strictly	.. 0 33
Solder, guaranteed	.. 0 35
Babbitt metals	.. 14 to 60
Soldering coppers, lb.	.. 0 53
Putty, 100-lb. drums	.. 4 00
White lead, pure, cwt.	.. 14 25
Red dry lead, 100-lb. kegs, per cwt.	.. 13 87
Glue, French medal, lb.	.. 0 25
Tarred slaters' paper, roll	.. 0 93
Gasoline, per gal., bulk	.. 0 31 1/2
Benzine, per gal., bulk	.. 0 30 1/2
Pure turpentine, single bbls., gal.	.. 0 49
Linseed oil, raw, single bbls.	.. 1 43
Linseed oil, boiled, single bbls.	.. 1 43
Plaster of Paris, per bbl.	.. 2 50
Plumbers' oakum, per cwt.	.. 8 00
Packing, square braided	.. 0 27
Packing, No. 1 Italian	.. 0 25
Packing, No. 2 Italian	.. 0 25
Lead wool, per lb.	.. 0 15
Pure Manila rope	.. 0 29 1/2
Transmission rope, Manila	.. 0 37 1/2
Drilling cables, Manila	.. 0 32 1/2

POLISHED DRILL ROD.

Discount off list, Montreal and Toronto	.. 25%
---	--------

CARBON DRILLS AND REAMERS.

	Per Cent.
S.S. drills, wire sizes up to 52	.. 40
S.S. drills, wire sizes, No. 53 to 80	.. 25
Standard drills to 1 1/2 in.	.. 40
Standard drills, over 1 1/2 in.	.. 15
3-fluted drills, plus	.. 10
Jobbers' and letter sizes	.. 40
Bit stock	.. 40
Ratchet drills	.. 15
S.S. drills for wood	.. 40
Wood boring brace drills	.. 25
Electricians' bits	.. 30
Sockets	.. 30

Sleeves	.. 40
Taper pin reamers	.. 20
Drills and countersinks	.. list plus 30
Bridge reamers	.. 45
Centre reamers	.. 10
Chucking reamers	.. 10
Hand reamers	.. 15

COLD ROLLED SHAFTING.

At mill list plus 40%
At warehouse list plus 50%

Discounts off new list. Warehouse price at Montreal and Toronto.

IRON PIPE FITTINGS.

Canadian malleable, A, add 10%; B and C, 10%; cast iron, 35%; standard bushings, 50%; headers, 60; flanged unions, 40; malleable bushings, 50; nipples, 55; malleable lipped unions, 50.

SHEETS.

	Montreal	Toronto
Sheets, Black, No. 28	..\$7 75	\$7 35
Sheets, Black, No. 10	.. 7 10	7 00
Canada plates, dull, 52 sheets	.. 7 00	7 00
Canada plates, all bright	.. 8 00	8 00
Apollo brand, 10 1/2 oz. galvanized	.. 7 25	7 25
Queen's Head, 28 B. W.G.	.. 7 75	7 75
Fleur-de-Lis, 28 B.W. G.	.. 7 45	7 35
Gorbals Best, No. 28	.. 8 25	7 50
Colborne Crown, No. 28	.. 8 00	6 75
Premier, No. 28 U.S.	.. 8 30	8 20
Premier, 10 1/2 oz.	.. 8 60	8 50

PROOF COIL CHAIN.

1/4 in.	.. \$9 45
5-16 in.	.. 9 10
3/8 in.	.. 8 35
7-16 in.	.. 7 15
1/2 in.	.. 6 95
3-16 in.	.. 6 35
5/8 in.	.. 6 80
3/4 in.	.. 6 70
7/8 in.	.. 6 55
1 inch	.. 6 40

Above quotations are per cwt.

ELECTRIC WELD COIL CHAIN B.B.

1/8 in.	.. \$15 50
3-16 in.	.. 11 70
1/4 in.	.. 8 40
5-16 in.	.. 7 40
3/8 in.	.. 6 35
1/2 in.	.. 6 35
5/8 in.	.. 6 35
3/4 in.	.. 6 35

FILES AND RASPS.

	Per Cent.
Great Western, American	.. 55
Kearney & Foot, Arcade	.. 55
J. Barton Smith, Eagle	.. 55
McClelland, Globe	.. 55
Whitman & Barnes	.. 55
Black Diamond	.. 45
Delta Files	.. 40, 5
Nicholson	.. 45
Globe	.. 55
Vulcan	.. 55
Disston	.. 55

COAL AND COKE.

Solvay Foundry Coke
Connellsville Foundry Coke
Yough Steam Lump Coal
Pittsburgh Steam Lump Coal
Best Slack
Net ton f.o.b. Toronto

BOILER TUBES.		
Size.	Seamless	Lap-welded
1 in.	\$24 00
1 1/4 in.	30 00
1 1/2 in.	32 00	25 00
1 3/4 in.	32 00	25 00
2 in.	35 00	26 00
2 1/2 in.	44 00	33 00
3 in.	47 00	38 00
3 1/2 in.	45 00
2 1/2 in.	59 00	48 00
4 in.	74 00	60 00

Prices per 100 feet, Montreal and Toronto.

OILS AND COMPOUNDS.	
Castor oil, per lb.	27
Royalite, per gal., bulk.	16
Palacine	19
Machine oil, per gal.	26 1/2
Black oil, per gal.	13
Cylinder oil, Capital	45 1/2
Cylinder oil, Acme	36 1/2
Standard cutting compound, per lb.	6 15
Lard oil, per gal.	1 45
Union thread cutting oil antiseptic	68
Acme cutting oil, antiseptic	37 1/2
Imperial quenching oil	39 1/2
Petroleum fuel oil	12 3/4

BELTING—NO. 1 OAK TANNED.	
Extra heavy, single and double	30-5%
Standard	40%
Cut leather lacing, No.1	1 50
Leather in sides	1 35

TAPES.	
Chesterman Metallic, 50 ft.	\$2 00
Lufkin Metallic, 603, 50 ft.	2 00
Admiral Steel Tape, 50 ft.	2 75
Admiral Steel Tape, 100 ft.	4 45
Major Jun. Steel Tape, 50 ft.	3 50
Rival Steel Tape, 50 ft.	2 75
Rival Steel Tape, 100 ft.	4 45
Reliable Jun. Steel Tape, 50 ft.	3 50

WASTE.	
White	Cents per lb.
XXX Extra	20
Peerless	20
Grand	19
Superior	19
X L C R	18
Atlas	18
X Empire	18
Ideal	17
X press	16

COLORED.	
Lion	14 1/2
Standard	13
No. 1	13
Popular	11 3/4
Keen	10 1/2

WOOL PACKING.	
Arrow	25
Axle	20
Anvil	15
Anchor	11

WASHED WIPERS.	
Select White	12
Mixed colored	10
Dark colored	9

This list subject to trade discount for quantity.

RUBBER BELTING.	
Standard	40%
Best grades	20%

ANODES.	
Nickel	.50 to .54
Cobalt	1.75 to 2.00
Copper	.44 to .46
Tia	.49 to .56
Zinc	.23 to .25

Prices Per Lb.

COPPER SHEETS.	
Montreal Toronto	
Bars, 1/2 to 2 in.	55 00 53 00
Plain sheets, 14 oz.
14x28 in., 14x60 in.	55 00 53 50
Copper sheet, tinned, 14x60, 14 oz.	60 00 54 25
Copper sheet, planished, 14x60 base.	64 00 60 00
Braziers' in sheets, 6x4 base	55 00 52 00

BRASS.	
Brass rods, base 1/2 in to 1 in rd.	0 55
Brass sheets, 8 in. wide, 20 oz.	0 60
Brass tubing, seamless.	0 57
Copper tubing, seamless.	0 58

PLATING SUPPLIES.	
Polishing wheels, felt.	2 10
Polishing wheels, bull-neck	1 35
Emery in kegs, American	06
Pumice, ground	04
Emery glue	15 to 20
Tripoli composition	04 to 06
Crocus composition	07 to 08
Emery composition	08 to 09
Rouge, silver	35 to 50
Rouge, powder	30 to 35

Prices Per Lb.

LEAD SHEETS.	
Montreal Toronto	
Sheets, 3 lbs. sq. ft.	\$16 00 \$16 00

Sheets, 3 1/2 lbs. sq. ft.	16 00	16 00
Sheets, 4 to 6 lbs. sq. ft.	15 50	15 50
Cut sheets, 1/2c per lb. extra.		
Cut sheets to size, 1c per lb extra.		

PLATING CHEMICALS.	
Acid, boracic	\$.15
Acid, hydrochloric	.05
Acid, hydrofluoric	.14 1/2
Acid, nitric	.10
Acid, sulphuric	.05
Ammonia, aqua	.08
Ammonium carbonate	.15
Ammonium chloride	.11
Ammonium hydrosulphuret	.40
Ammonium sulphate	.07
Arsenic, white	.12
Copper, carbonate, anhy.	.35
Copper, sulphate	.17
Cobalt sulphate	.70
Iron perchloride	.20
Lead acetate	.16
Nickel ammonium sulphate	.12
Nickel carbonate	.35
Nickel sulphate	.15
Potassium carbonate	.75
Potassium sulphide (substitute)	.20
Silver chloride (per oz.)	.65
Silver nitrate (per oz.)	.55
Sodium bisulphite	.10
Sodium carbonate crystals	.05
Sodium cyanide, 127-130%	.41
Sodium hydrate	.04
Sodium hyposulphite, per 100 lbs.	5.00
Sodium phosphate	.14
Tin chloride	.60
Zinc chloride	.60
Zinc sulphate	.09

Prices Per Lb. Unless Otherwise Stated.

The General Market Condition and Tendency

THE upward movement in prices of steel continues in the United States in spite of the low figures fixed on the requirements of the American Government. This situation is reflected in Canada and prices of domestic steel products are advancing as well as on imported materials. The congested condition at the mills and increased demand is largely responsible for the prevailing tight situation in the steel market. The more important advances to be noted this week include plates, wrought pipe, black and galvanized sheets. Prices of pig-iron continue very firm and quotations on domestic iron are now approximately \$47. This figure is entirely nominal owing to the uncertain conditions in the market. The demand for pig-iron is heavy, but the furnaces are sold up for several months and stocks are low. The coal situation is somewhat easier, although higher prices are expected. The coke market is strong and prices continue high. Prices of scrap metals are unchanged and the market dull in regard to copper and brass. The demand for steel scrap, however, is active, and higher prices are likely. Non-ferrous metals are dull, the only change to be noted is in spelter, which has declined. Copper is showing a weaker tendency and lower prices appear probable in the near future. Decline in prices of high-speed twist drills has been announced, but wood screws and rubber belting have advanced. The machine tool market is quiet and situation generally unchanged.

Montreal, Que., April 16, 1917.—The industrial situation is slowly adjusting itself to the changed conditions arising out of the recent American developments, but no material effect has yet become evident as to the direct bearing such a move will have on the trade relations of this country. With the complete adoption of definite plans, however, it is generally expected that some changes will naturally follow, although it is yet early to decide

just what form these changes will take. The combined efforts of the United States Government and the Allied countries cannot have other than a beneficial effect upon general conditions, although in the abstract these conditions may appear to conflict with domestic progress. Shell activity continues at a satisfactory rate and the shipbuilding industry is also active, although somewhat handicapped by the lack of construction facilities and

the pronounced scarcity of suitable ship plates. Manufacturers here are experiencing considerable difficulty in obtaining sufficient raw materials to operate at capacity, owing to the congested condition of the producing mills and the inability to secure reliable delivery.

Pig Iron.

The sensational rise in pig iron is undoubtedly the feature of the market for the week, if the continual advance can be considered as a feature. The demand for all grades of pig apparently has no end, and the excessively high prices have had no evident effect in restricting the call from consumers. The outstanding advance of the week has been that on Bessemer and forge, each being subjected to an advance of \$5 per ton. The former is now quoted at \$45.95 and the latter \$41.95 per ton, Pittsburgh. The rise in other grades has been quite general, the composite price of pig iron being \$39.56, this being \$2.10 higher than last week. Conditions locally are unchanged, with Canadian quotations on the nominal basis of \$46.50 per ton.

Steel.

Developments have not yet reached the stage where general conditions have been affected by the entrance of the United States into the war, and the market is consequently in a more or less unsettled condition. It is anticipated that supplies for the American government will be rushed out by several of the large mills, and will not seriously affect the delivery of material that has been on order for previous customers, although some little delay may be necessary in the shipment of the same. So far the Canadian situa-

tion has not been affected by the changed situation on the other side and dealers here do not expect that conditions will be varied to any great extent by recent or coming developments. With improved transportation facilities, the interest of the consumer has again reverted to the problem of the mills and their inability to supply the full requirements of the trade. The sold-up condition of most of the steel mills and the non-cancellation feature of contracts, makes the future of the steel industry one of extreme firmness; the activity of the shipbuilding trade throughout both Canada and the United States also adds to the present and future strength of the market. The problem of marine tonnage is becoming one of paramount importance and plate mills are experiencing the most active period in their history. Bessemer products have already shown a similar advance to that of the raw material, namely, \$5 per ton; the current quotation on billets and sheet bars being \$80 per ton, Pittsburgh. Wire rods on a similar advance, are now bringing \$90 per ton. The Pittsburgh quotation of forging billets has for the first time attained the phenomenal figure of \$100 per ton, the most recent advance being \$10 per ton. These abnormal advances are the direct cause of the demands of the U.S. Government and the congested condition of the mills, but fortunately the greater number of consumers are covered by contract and recent advances will have little effect upon their current or future business. The coke situation has improved but recent developments have placed producers in a waiting position, as they will probably have to adjust their future schedule to conform with the policy of the government. Spot furnace has regained some of its lost strength, the week's advance of 50 cents bringing the current quotation back to \$8.50 per ton. Owing to an apparent scarcity of prompt ferromanganese, the price has advanced to \$400 per ton, this being \$75 higher than a week ago. The programme of the American government in connection with shipbuilding will likely necessitate the increased output of plates for this purpose and may in consequence, temporarily effect the delivery to their consumers, so that the early prices of this commodity may be subjected to a still further advance. It is practically impossible to place orders for ship plates or tank plates and receive assurance of delivery earlier than the middle of 1918. The demand on the lighter sheets has been increased owing to probable early activity in connection with war supplies. Tin plate mills likewise are anticipating greater activity in view of the possible needs for army and other purposes. While wire products have retained a very firm and steady position for some time, early future conditions may be reflected in the fact that some of the American producers have all but withdrawn from the market, only quoting on specific inquiry from regular customers. This feature of the wire situation may be the preliminary to another advance on these products, and the week's advance on wire rods will also affect the

early future of wire quotations. The sold up condition of the tube mills makes the market one where premiums can be readily secured by those mills that are able to guarantee reasonably prompt delivery. The exceedingly heavy demand for these products has placed the mills in a very strong position and orders are being placed for second quarter 1918 delivery. Producers of bolts and nuts anticipate an early readjustment of price quotations in an upward direction. The pressure on the wrought iron pipe mills is fast becoming like that of the plate mills, many of them having future orders, which run well into 1918. Dealers here report general conditions unchanged, but very firm and would not be surprised to see higher prices in various lines of steel. Supplies are now very low, and it is difficult to get material forwarded from the mills.

Metals.

Nothing has transpired to feature the metal situation and the general market conditions are unchanged; but prices, with the exception of lead, have developed a weaker tendency. Efforts on the part

CANADIAN GOVERNMENT PURCHASING COMMISSION

The following gentlemen constitute the Commission appointed to make all purchases under the Dominion \$100,000,000 war appropriation:—George F. Galt, Winnipeg; Hormidas Laporte, Montreal; A. E. Kemp, Toronto. Thomas Hilliard is secretary, and the Commission headquarters are at Ottawa.

of the consumers to dispose of surplus metal have resulted in a weaker market. Tin is unsettled but fairly firm, but with an easier undertone. Spelter is becoming weaker on a dull market. Lead is steady and stronger locally. Antimony is quiet but firm.

Copper.—Market conditions are apparently being reflected in the fact that sellers at present are more in the lime-light than buyers. The situation is one where the consumers of copper are taking a marked interest in the trend of affairs, not that any definite knowledge of future conditions is the basis of their action, but more in view of these possibilities that might arise out of the recent attitude of producers, in supplying metal to the government at greatly reduced prices. This feature of an abnormal situation has created a certain degree of anxiety among those users of copper that are well supplied with metal for future use, and many of these are offering quantities of their surplus stock for sale, hoping to realize at current high prices before a possible decline takes place. Both producers and consumers appear to be playing a waiting game, the former expecting that the requirements of the trade will start a buying movement, while, on the other hand, consumers are expecting further declines

on copper quotations. The present tendency is to lower levels. London reports a continued firmness, while New York is easier on an unsettled market; lake having fallen off one cent, and electro and castings 1¼c. per pound, the current quotations being 33½c, 33c, and 30c per lb. respectively. On a quiet market dealers here have declined their quotations 1½c. per lb., the prices asked being 38c. for lake and electro, and 37c. for castings.

Tin.—Despite the fact that no marked activity has taken place during the week, tin continues to maintain a very steady position, and quotations are a little stronger. It was expected that certain concessions might be made regarding the shipment of metal and the freer granting of permits to American ports, but so far nothing has been done in this connection to relieve the situation on this side of the water. Hopes are entertained, however, that some early arrangements will be made by which the available supply will be more in keeping with the requirements of the trade. A factor that has become more pronounced since the entrance of the United States into the war, is the increasing need to secure tin for canning purposes; for this, and other reasons, American consumers are anxious that better facilities be provided for the greater supply of metal that will be required for early future requirements. Higher prices feature both the London and New York markets; the latter having advanced ¼c. during the week, the nominal quotation being 55c. per lb. On a fairly active market tin has declined locally to 55c., this being ½c. lower than last week.

Spelter.—The dull period in the spelter market, followed by the recent activity on the part of producers, in seeking orders for second quarter business, has had the effect of developing a weak situation and lower prices are resulting. The demand for prompt metal is very light and not much resale spelter is available, but the movement of producers in seeking buyers has emphasized the dullness. London remains firm but New York reports a decline of ½c. for the week, the price now quoted being 10c. per lb. The local market is dull and weaker, having declined 1c. on the week, the current quotation being 14c. per lb.

Lead.—The market is quiet and comparatively dull, but the sold-up condition of the producers is the chief factor in maintaining this metal in its present strong position. Rumor is current that negotiations are proceeding whereby the U.S. government will be supplied by American producers at a figure greatly below that prevailing on the open market. No verification of this is at present available, but report has it that the price paid will be below 5 cents. Until the attitude of the producers is known it is very unlikely that the market will see little change from existing conditions. London and New York are both very firm, the prices quoted on the New York market being 9c. by the leading interests and 9½c. by independents. Lead is stronger here on a ¼c. advance, the price asked being 12½c. per lb.

Antimony.—This metal is quiet and prices are developing a weaker tendency. Spot metal is still scarce, but the supply is showing improvement. A decline of $\frac{1}{2}$ c. is noted on the New York market, the present price being $35\frac{1}{2}$ c. per lb. Dealers here report a quiet situation with quotations steady.

Machine Tools and Supplies.

No important developments have taken place in machine tool circles, and conditions are generally unchanged. The demand for shell-making equipment is gradually falling off, although a fair business is still carried on in filling orders for single machines of both special and standard design. To offset this situation, however, increased demand for machines for domestic purposes is an encouraging feature, and while the volume at present is not great, the outlook is encouraging. Shipbuilding prospects are developing, but no abnormal requirements have yet been called for by the machine tool builders. Dealers here are being advised daily of advances on all classes of machine equipment, and these conditions are expected to continue while the upward movement in raw materials dominates the market.

Scrap.

Owing to the uncertainty that seems to dominate the entire industrial situation the market in old materials is very unsettled, although prices are generally in a steady condition. Business is fairly brisk in all lines. New York prices on steel scraps are well maintained but quotations on old metals show a weaker tendency. Copper and brass scraps have declined locally while iron and steel has shown a slight advance; light copper is lower by 2c., being quoted at 22c.; crucible, heavy and wire, have declined $1\frac{1}{2}$ c., the prices quoted being 28c. per lb.; brass clippings on a decline of 1c. are quoted at 18c.; machine compositions are similarly affected, the price being $22\frac{1}{2}$ c.; heavy melting steel and old rails are bringing 19c., this being 2c. higher than last week; boiler plates are bringing 18c., an advance on the week of 3c. per lb. Machine cast iron, at 21c., is 1c. higher than last week.

Toronto, Ont., April 17.—The industrial situation continues favorable, although the continued increase in prices of raw materials and in some cases shortage of supplies is handicapping manufacturers. The possibility of higher prices on coal is also an important factor in the situation. The opening of navigation on the lakes will help to relieve the situation, but conditions at the mines are not any too favorable.

Steel

Developments in the steel market in the United States are being followed closely by Canadian interests, as the trend of events there will be reflected in this country. The fixing of prices between the steel makers and the American Government has not as yet affected the steel market at all, probably because of the comparatively small tonnage at

present involved. There is still some possibility of the Allied Governments sharing in the U. S. Government's arrangements, in which event the aspect of the situation would be changed. Furthermore, the requirements of the American Government may ultimately develop into considerable tonnage, a contingency which would likely have an important effect on the situation. In the meantime prices are steadily advancing. A halt in the upward movement seems unlikely, as the mills are sold to capacity for several months ahead, and the demand for steel is on the increase. Owing to developments in the States, private consumers in Canada importing steel material may suffer from a further delay in deliveries and higher prices. For instance, prices of plates and black sheets have again advanced. Plates are now quoted at \$7.50, and heads at \$7.60 per 100 lbs. The demand for plates continues very heavy and some mills, it is reported, are refusing tonnage, being unable to accept any more business owing to the difficulty of making deliveries. Makers of cut nails have raised their prices to \$5 per keg base. Wrought pipe has made another advance, the fourth in a very short period.

Prices of black sheets have advanced approximately 50c, No. 28 gauge being now quoted at \$7.35, and No. 10 at \$7 per 100 lbs. Premier 10 $\frac{3}{4}$ oz. are higher at \$8.50, and No. 28 U. S. are \$8.20 per 100 lbs. The demand for black sheets is heavy and the market very firm.

Prices of steel products in the United States continue to advance in spite of the recent fixing of prices to the Government. The agreed prices are \$2.90 for plates and \$2.50 for structural shapes and steel bars. Operating schedules have been arranged to give the Government material precedence over all other business. Although these figures represent a substantial concession, current prices have not been as yet affected; in fact, indications point to higher prices on steel rather than a revision to lower levels, as predicted in some quarters. Bessemer and open-hearth billets are now \$75, forging hillets \$100, and open-hearth sheet bars \$77.50, all f.o.b. Pittsburgh. The expectation of heavy Government requirements and congested condition at the mills on both Bessemer and open-hearth steel is largely responsible for the heavy advance in prices. Chicago warehouse prices of plates have advanced to 6c.

Pig Iron

The pig iron market continues strong, but it is difficult to name a firm price, as the situation is so uncertain. While \$47 might be quoted on domestic foundry iron, this price is entirely nominal, and is liable to advance any day. The tight situation is largely due to the heavy demand for pig iron and sold-up condition of the furnaces, while stocks are also very low. Although \$45 is being quoted at Buffalo for fairly good delivery, there is very little iron available, a situation which is reflected over here. The current prices on a few American pig irons are higher than last week, and are as

follows:—Basic Valley furnace, \$38; Bessemer, Pittsburgh, \$42.95; Grey Forge, Pittsburgh, \$37.95; No. 1 foundry, Buffalo, \$45.

Scrap

Prices of copper and brass scrap are easier, although they are unchanged; in the meantime a decline appears to be probable. The weakness is due to the changed outlook for copper rather than to any material falling-off in demand. Prices of all steel scraps are firm, with a higher tendency. There is a good demand for steel scrap, and also for low phosphorus pig iron. The demand for steel borings and turnings is not heavy, as consumers seem to be well supplied.

Machine Tools

There is practically no change in the situation in the machine tool market. The demand for tools for munition plants is light, a few single tools representing the general run of business. There has been some inquiry for shipyard machinery during the week, and a few orders have been placed with local dealers. More business in this class of equipment is expected.

Supplies

There are indications of declining prices on high-speed steel. A new discount of list plus 90 per cent. has been made on high-speed drills up to $\frac{1}{2}$ in., and double list plus 10 per cent. on high-speed drills up to $1\frac{1}{2}$ in. Files have advanced, the new discount being 55 per cent. Prices of rubber belting are up; standard is now 40 per cent., and best grades 20 per cent. off list. An advance has been made in wood screws, the new discount on flat head bright being $72\frac{1}{2}$ per cent., as against 75 per cent. formerly. Turpentine has advanced 2c to 75c per Imperial gallon.

Metals

There have been no important developments in the markets during the week, all metals are dull, due largely to the uncertain situation. This condition appears likely to continue until something more definite is known in regard to the requirements of the American Government. Copper is affected to a greater extent perhaps than other metals owing to the low price recently fixed on U. S. Government purchases.

Copper.—Little interest is being displayed in the copper market, and prices continue nominal and unchanged. There is, however, an easier undertone to the market, and there is a possibility of lower prices as a result of the recent sale to the U. S. Government at a considerably reduced figure. Local prices are unchanged in the meantime, lake and electrolytic being quoted at 40c and castings at 39c per pound.

Tin.—The market is firm and prices continue entirely nominal. The trade in the States is disturbed on account of the uncertainty caused by the restrictions placed upon shipments of tin from London and the East by the British Government, and the fear that limitations may be increased still further. Local quotations are firm and unchanged at 56c per pound.

Spelter.—Prices have declined locally in sympathy with an easier situation in the States. There appears to be some price shading by producers owing to falling off in demand and continued large production. Prices have declined 1c locally, and spelter is now quoted at 13c per pound.

Lead.—The sold-up condition of producers is holding the lead market firm, although business is not particularly active. Local price, 12 $\frac{1}{4}$ c per pound.

Antimony.—The scarcity of spot metal continues, and prices are still nominal. Quotations firm and unchanged at 36c per pound.

Aluminum.—The market is quiet but firm, and quotations are unchanged at 68c per pound.



THE PASSING OF JIM BRADY

James Buchanan Brady, wealthy steel car manufacturer, well known to Broadway, New York City, and the business interests of the United States generally, died in the Hotel Shelburne, Atlantic City, N.Y., on April 13. Although his decease was anticipated, being at longest a matter of a few months, its immediate suddenness was wholly unexpected. In view of the varied nature of his career and his somewhat unique personality, our readers will doubtless find the following biographical sketch from the New York *Sun* of more than passing human interest.

Man of Business and Pleasure.

One book would be all about the James Buchanan Brady, of the daylight hours, voluntarily the hardest worked man in his offices at 170 Broadway, acknowledged "the best salesman in the country," a capitalist who at a pen stroke, had he cared to do it, could come close to shutting up an entire city of 25,000 souls in western Pennsylvania, inasmuch as almost the entire town is employed by his Standard Steel Car Company, and the company practically owns the town.

The biographer's other book would be even more spectacular, and it wouldn't have a line in it about James Buchanan Brady at all. Instead, it would have to do altogether with the Diamond Jim Brady who nightly came into being in the theatrical and restaurant region of Longacre Square when dusk fell—the Diamond Jim ablaze with the thousands upon thousands of dollars worth of jewels which gave him the sobriquet by which Broadway knew him; seated in restaurants before quantities of food so appalling that nearby diners, fascinated, let their own meals grow cold as they watched him demolish the dozens of raw clams or oysters and the piles of bread and catsup which he consumed while waiting for the soup and the birds or the double steaks and vegetables that always followed. He would finish a pound box of candy in five minutes.

A Great Patron of the Theatre

And much would have to be written about the Diamond Jim seated, now ablaze with still another set of jewels in an aisle chair in the front row on theatrical opening nights, while prima donnas or show girls nodded to him from the stage or, as sometimes happened, a privileged comedian on a first night boldly said, "Hello, Jim," over the footlights. And more than a chapter could be given to the monumental midnight supper after the performance, Diamond Jim, surrounded by troops of the love-

liest ladies of the stage and, finally, one-stepping in a Broadway trottery until the roosters began to crow—easily the most popular man at the party.

So, from dusk until almost dawn, the Diamond Jim Brady would play with as much genuine relaxation as the James Buchanan Brady would labor with intensity in the financial district during daylight hours. And after a few, a very few hours of rest in his home at 7 West Eighty-sixth street, where his household consisted chiefly of Yamas, who was his faithful Japanese valet and guardian of the jewels, and his dog and the little cat he had picked up on the street in Baltimore and had made a pet of, Diamond Jim would become James Buchanan Brady again.

He never took an alcoholic drink in his life, never used tobacco in any form and he drank no tea or coffee. His constitution had a great deal of his own steel car construction in it, wherefore, despite the wracking nature of both his work and his play, he lived intensely night and day for many years before the final smash came.

He Had 200 Suits of Clothes.

Younger men who had tried the all-night parties of Broadway every night came and went, mostly went, the youngsters lasting only months or even weeks during the uninterrupted years that Diamond Jim was steadily adding glitter and picturesqueness to Broadway night life because of his 200 suits of clothes and his thirty sets of jewelry, each set consisting of fifteen pieces and five of the sets valued at \$100,000 each.

The younger men who were mowed down quickly could recuperate somewhat, too, by sleeping all day, whereas Diamond Jim arose early and now a quick thinking, soft spoken, alert James Buchanan Brady—was among the first on the job down town. But the youngsters who cracked under the strain usually dropped into bed drugged with alcohol and nicotine; Diamond Jim's excesses consisted solely of overdoses of the most excellent foods obtainable.

In the Brady biography there would have to be chapters in the Diamond Jim book also about his racing days, when he owned the crack \$30,000 Oisean and Gold Heels and other thoroughbreds. Back in those glad days his massive figure would wedge itself into the betting ring, sheaves of yellowbacks between his bejewelled fingers, and the bets he placed were of a size that made the bookies think hard.

Yells at Joy of Winning.

Once a Brady picking began to nose out of the ruck and light out for the finish with nothing in front of it but daylight even a blind man would know what was happening. For Diamond Jim, jumping to his feet in the grand stand, his heavily jowled face aglow with the ecstasy of the moment, would let loose bellowing yells of sheer joy that arose above the roars of the crowd and the blare of the band and the thunder of swift hoofs pounding past through the sunlit dust clouds. There are fans who believe that the echoes of those Brady yells still are haunting the deserted weed grown tracks.

When the Governor of the State brought an end to the Percy-Gray law and racing was ended, no darky stable boy or glum little jockey grieved more than Diamond Jim.

"Listen," he said solemnly to his office force in a little speech he made to his employees on the eve of a subsequent election day which was to decide whether or not the same Governor was to be returned to office. "I don't like to butt in on the politics of any man working here and I wouldn't discharge anybody for voting wrong to discharge. But But!—if any one here casts a vote for this John J. Jungleface for Governor to-morrow and I find it out, then that mem-

ber of this staff is going to lose my liking for him, that's all."

Gets New \$250,000 Stomach.

So great was the publicity which attended Mr. Brady's so-called "new \$250,000 stomach" in the summer of 1912—meaning thereby a recovery from kidney and stomach lesions following surgical and medical treatment at Johns Hopkins Hospital which enabled him to return to Broadway and momentous meals again after months of forced abstinence—the reading public, fed chiefly with happy yarns about the "new Brady stomach," almost lost sight of the scientific importance of his very fine gift to the Baltimore institution.

Upon his departure from Johns Hopkins, comparatively a well man again, Mr. Brady promptly handed over a sum in the neighborhood of a quarter of a million dollars to Johns Hopkins as an initial contribution for the building and maintenance of the James Buchanan Brady Urological Institute. Furthermore, he guaranteed at the same time an annuity of \$15,000 to go toward the upkeep of the institute, and in a letter to Dr. Hugh H. Young, professor of urological surgery at Johns Hopkins, he said when forwarding his cash gift that he had just added a clause to his will providing for "a substantial sum" to be devoted to the future needs of the institute.

Pitied Other "Poor Devils."

Journalestic wags, who for years had been having much good natured fun at Mr. Brady's (rather at Diamond Jim Brady's) expense, may have written chiefly about the new "\$250,000 stomach," but the medical and surgical world in general, and Baltimore in particular, appreciated the splendid gift at its real value. Here was a new unit in a great medical institution where not only "other poor devils can be made well again," as Mr. Brady put it, but which enabled Dr. Young and his assistants to do surgical and pathological research in urology upon a scale and with a scientific equipment which previously had been impossible.

There was a "Brady day" of civic importance in Baltimore when the institute was dedicated on May 4, 1915. Hand clapping finally was lost in cheers that day as the donor, blushing like a particularly adipose schoolboy, was thrust into the limelight to make a speech to the assembled civic dignitaries.

The Brady speech took up only a paragraph in the newspapers the next morning. At the end of the speech Mr. Brady would have become Diamond Jim again and hurried right back to his beloved Broadway had not Baltimore insisted upon a public reception, during which he was again forced into the spotlight.

He Gave Freely to the Poor.

Then there was a banquet in his honor in the evening, and when the coffee had been served some of the foremost men in public life in Maryland and great scientists and others of the mighty arose and told Mr. Brady that he was a big-hearted and altogether remarkable man—facts which wealthy associates and his proteges among the poor here had known for many years.

The aid he gave to the poor that came to him (and Diamond Jim's charities that became known were many), doubtless was given all the more heartily because for a long time he also had been very poor. He was horn of Irish parents in Cedar street, on August 12, 1856. In the New York public schools he got the elements of learning, but he had to give up his books when a little chap and begin to earn his own living, first as an office boy with a downtown law firm. He was a messenger for a while also, and, in his youth, a baggage-man at the old Grand Central station.

Then he got a job with the firm of Manning, Maxwell & Moore, machinery manufacturers, and early showed signs

Landis Grinders for Production

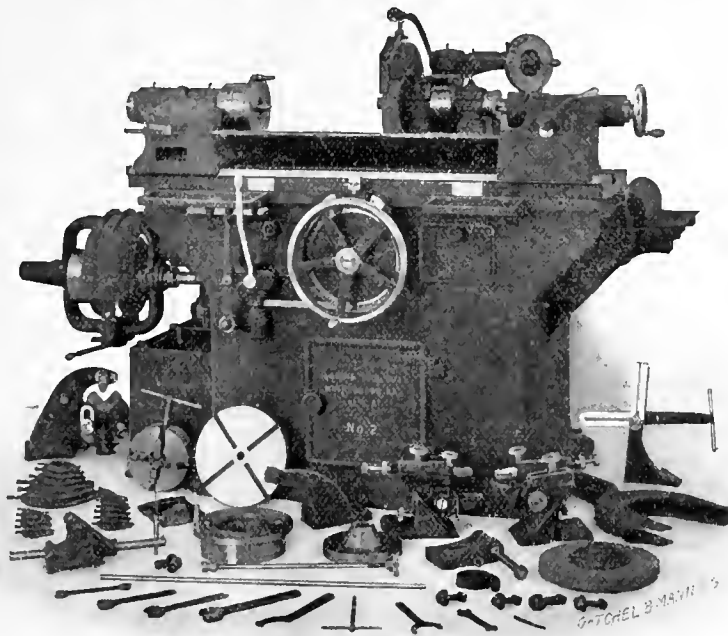

No. 1. UNIVERSAL

Capacity 10" x 20"

will do all kinds of

INTERNAL and EXTERNAL
CYLINDRICAL (Straight and taper)
and CUTTER GRINDING

*It has many special features giving
CONVENIENCE, ACCURACY and
PRODUCTION*

Write for bulletin giving de-
tailed description and prices.
INSTOCK for immediate ship-
ment

**"IF IT'S MACHINERY
WRITE WILLIAMS"**

THE A. R. WILLIAMS MACHINERY CO., Ltd. 64 FRONT ST. WEST
ST. JOHN, N.B. WINNIPEG TORONTO VANCOUVER

AN UNUSUAL TOOL?

No. It is a Geometric Collapsing Tap.

Only one of the many specially arranged Geometries. This Tap is tapping Projectile Caps a foot deep, 5.378-in. diameter, 10 pitch.

Geometric Collapsing Taps are arranged for all classes of thread tapping above 3/4-in. diameter. Rigid while tapping, but collapse the chasers when the required depth is reached.

Can be fitted for Screw Machine or Turret Lathe, also to live spindle, such as Drill Press.

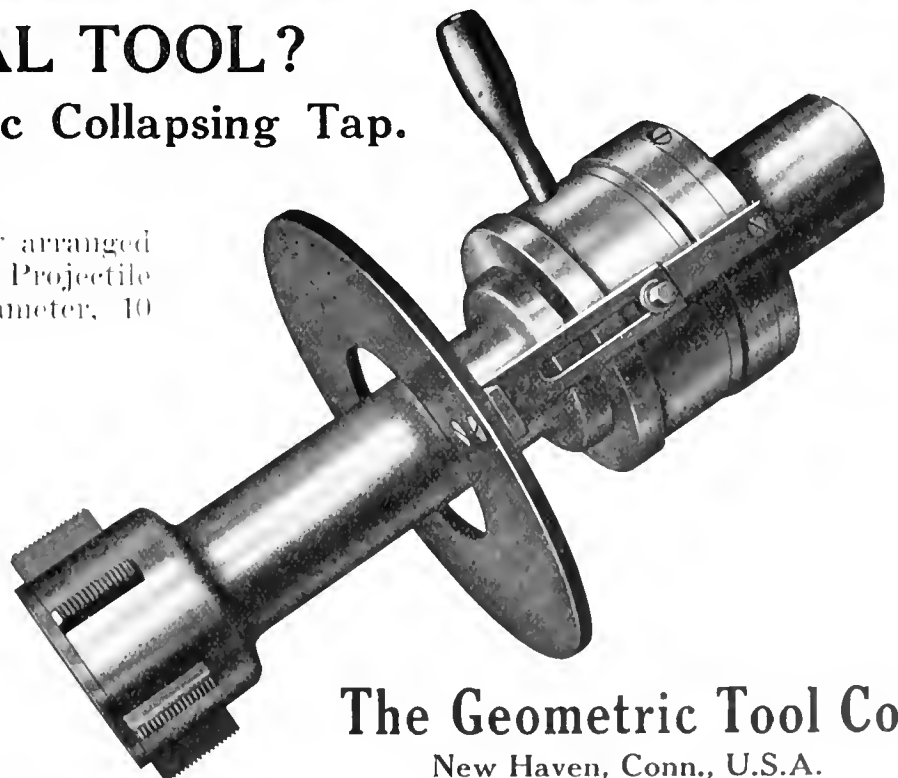

The Geometric Tool Co.
New Haven, Conn., U.S.A.

Get acquainted through our
catalogue.

Canadian Agents:
Williams & Wilson, Ltd., Montreal, The A. R. Williams Mch.
Co., Ltd., Toronto, Winnipeg, St. John, N. B.

If any advertisement interests you, tear it out now and place with letters to be answered.

INDUSTRIAL ^A_N^D CONSTRUCTION NEWS

Establishment or Enlargement of Factories, Mills, Power Plants, Etc.; Construction of Railways, Bridges, Etc.; Municipal Undertakings; Mining News

ENGINEERING

Goderich, Ont.—The Goderich Dry Dock & Shipbuilding Co. propose building a ship-repairing plant here.

Ottawa, Ont.—T. Lawson & Sons Machine shop on Wellington Street, was destroyed by fire recently. The damage is estimated at \$8,000.

Vancouver, B.C.—The School Board contemplate making additions and improvements to the heating and ventilating plants in a number of schools here.

Vancouver, B.C.—The Great Northern and Northern Pacific Railways who are constructing a new union terminal here, will build machine shops, boiler house and water tanks in connection with the scheme.

Collingwood, Ont.—William Kennedy & Sons have applied for an additional 1,000 h.p. from the Hydro Commission for use with the electrical furnaces, which they are about to instal at their steel plant here.

Guelph, Ont.—The International Malleable Iron Co. are installing a new 20-ton milling furnace and three annealing ovens in the 216 ft. extension which they

are building to their foundry. A new warehouse and shipping room will also be built.

London, Ont.—Plans have been prepared for the new foundry which Beatty Bros., of Fergus, propose building here.

Lethbridge, Alta.—Good progress is being made with the development of a coal mine at Taber. A four-mile spur is being constructed to the mine from the C. P. R.

Port Arthur, Ont.—The Ontario Hydro-Electric Commission will not proceed with the development of the Nipigon water power, as such a scheme is considered to be detrimental to the interests of the city.

Toronto, Ont.—Shipments of ore and concentrates from the property of the Kenyon Copper Mines, near Massey Station, have been resumed after several weeks spent in overhauling and enlarging the concentrating mill and flotation system. The stated capacity of the mill is now about 200 tons per day. The steam plant which has also been enlarged, is now about 300 horse-power capacity.

Hamilton, Ont.—The National Abrasive Co. of Boston and Amesbury, Mass., manufacturers of carbolon an abrasive material for grinding and polishing purposes, have decided to locate in Hamilton and have bought an acre and a half of land on Biggar ave. near Lottridge street. They will start erecting a factory immediately and expect to start operations in 90 days. The equipment and material is being ordered through the Ritchey Supply Co. of Toronto, who are the selling agents for this concern in Canada. Nathan C. Harrison is president of the National Abrasive Co. and he has connected with him, J. T. Johnston, who is looking after the erecting and equipping of the Hamilton factory.

GENERAL

Montreal, Que.—The Montreal Box Board Co. will build an addition to its factory, to cost \$20,000.

Belleville, Ont.—R. J. Graham's evaporating plant was destroyed by fire on April 11. The tin shop, cold storage building and the chemical warehouse on Front Street were also burned. The total

of salesmanship ability that amounted almost to genius. He saved his money, and after he had been with the firm a few years he put up his savings to back a metal cutting saw and thus got his first real start toward riches. Then he became identified with the Fox Pressed Steel Company, subsequently the Pressed Steel Car Company, and finally with the Standard Steel Car Company, of which he was vice-president from the time it was organized until his death.

Started on "Beef and Beans."

"I began to eat away down town, where corned beef and beans cost a dime a plate," he told the New York Society of Restaurateurs when called upon for a speech at the restaurant men's annual dinner in 1916. "Then I got swell enough to go to my old friends, Smith & McNeill, where I could get one of the best meals of the day for 25 cents. And by degrees I edged my way up town until I was eating table d'hote dinners for 30 and even 40 cents. Finally I arrived right among you gentlemen. Since then I've eaten everything in sight except the tablecloths."

The one-time baggage smasher at the Grand Central Station was host at a dinner here which he gave at the end of the summer of 1912 to celebrate his recovery at Johns Hopkins. One of his guests was, at the time of the dinner, of some importance around that same Grand Central Station, the guest in question being Charles S. Mallen, president of the New York, New Haven and Hartford. Some time later, while testimony was being given before the Interstate Commerce Commission, it was learned that one of Mr. Brady's companies had sold the New Haven road—even the New Haven—more than \$8,000,000 worth of steel cars. One might reason from this that there was more careful thought and deliberation in selecting the guests at a James Buchanan Brady dinner than at the happy-go-lucky dinner

and supper parties given by Diamond Jim Brady.

Wonderful in Salesmanship.

His faculty for salesmanship was uncanny. Largely he got results because he was so close a student of detail as well as of men. He knew railroading well and he knew all about steel cars. If he thought a road needed something in his line he would take a trip over that line and soak in its needs by means of remarkable observation. Then he would call to see the president of that road and tell him that the line needed cars. If the official wouldn't agree with him out would come the Brady statistics and other data—exact figures to prove that the rolling stock was below standard. Usually he got the order.

Upon his death last week estimates were made of his fortune that ranged all the way from \$5,000,000 to \$10,000,000. His jewels, which he began to collect about twenty-five years ago, have been valued at \$1,200,000, most of which it was reported, will go to the Metropolitan Museum of Art. He had one diamond said to be worth \$50,000; sets of pearl, ruby, diamond, cat's eye and emerald, each valued at \$100,000; great shirt studs and rings crusted with perfect gems and literally as large in circumference as a fifty-cent piece—some even larger; rings, the jewels of which arose almost an inch above his knuckles in pyramids of glitter, the gold or platinum mountings that held the gleaming pyramid covering not only the finger upon which the ring was worn, but more than half of each of the fingers immediately adjoining as well; diamonds and rubies and pearls hidden beneath his clothing in the form of ornaments for suspender or garter buckles; a set of waistcoat buttons alone which more than represented the interest on \$1,000,000 at 4 per cent.—that was the way Diamond Jim Brady went in for jewelry.

Loved Gems as Works of Art.

And, oddly enough, he didn't wear his enormous jewels to impress others. Gems were a passion with him. He loved to wear them, to handle them and look at them even in the privacy of his own home—just as another type of man would find his greatest joy alone among his Corots, his Millets or his latest Velasquez. But the intellectually imaginative charm of a silvery Corot had no part in Diamond Jim's joys. His pleasures were sensuous and of the earth earthly—resplendent jewels, the loveliest among Broadway's stage beauties, who surrounded his restaurant tables in bevies; the richest of foods and the gayest of musical comedies.

If his voice was loudest at the racetrack when his horse was winning in the old days, he was the quietest at his parties. In the popular mind Diamond Jim Brady suggested bluster and noise and brag. Really he was quiet, almost solemn, in movement and speech. There was in fact a certain gentleness in the way he addressed one which those who talked with him found very winning and not at all what one would expect from a man of his massive form and heavy features.

Besides his vice-presidency of the Standard Steel Car Company he was a director of the Standard, president and director of the Independent Pneumatic Tool Company, vice-president and director of Manning, Maxwell & Moore, Inc.; president and director of the Thermoton Company, director of the United Injector Company, vice-president of the Keith Car and Manufacturing Company and of the Osgood Bradley Car Company, director of the Consolidated Safety Valve Company, and he was interested in several other enterprises connected with railroad products.

Aikenhead's M-6 Shell Machine

for cleaning out insides of 4.5 inch Howitzer and 6-inch shells and for retouching rough spots

This machine has been used with immediate success in a number of large shell factories in Canada. A 14½" special spindle is supplied for 4.5 shell work and a 20" spindle is used on 6" shell work. Specially adapted for cleaning the base of shells *inside*.

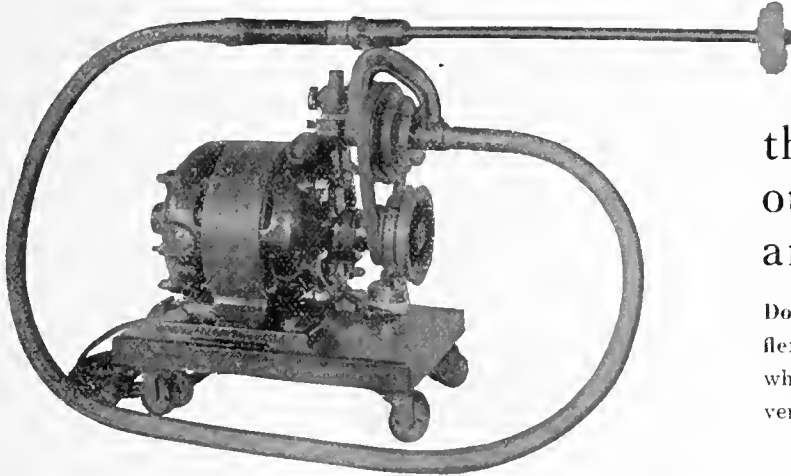

The Strand flexible shaft has a *metal casing* that will outwear any other now on the market and adds life to the shaft.

Does away with the trouble common to other flexible shafts. Freely flexible to a certain radius, where it automatically forms a stop, thus preventing accidental short bends.

For full particulars write.

Aikenhead Hardware Limited
17, 19, 21 TEMPERANCE STREET, TORONTO

Aikenhead's New Chuck

Don't Throw Away Broken Tang Drills

Perhaps you are about to discard some taper shank drills because the tangs are broken off—DON'T DO IT—they are worth their weight in gold. You can use them just as they are with a

Wahlstrom Automatic Chuck

One chuck holds drills from 1/16" to 1¼"

and you won't have to take time from your production to repair them.

Tool changes are made in two seconds—just grasp the shell of the chuck with one hand and put in or remove the tool with the other—no collets—no lost time, for the spindle never stops. The jaws grip NOT BY THE TANG, BUT ON THE SIDE OF THE TAPER—there's no chance for slippage—a Wahlstrom won't even mar the shanks.

Aikenhead Hardware Limited

17, 19, 21 Temperance Street - Toronto, Canada

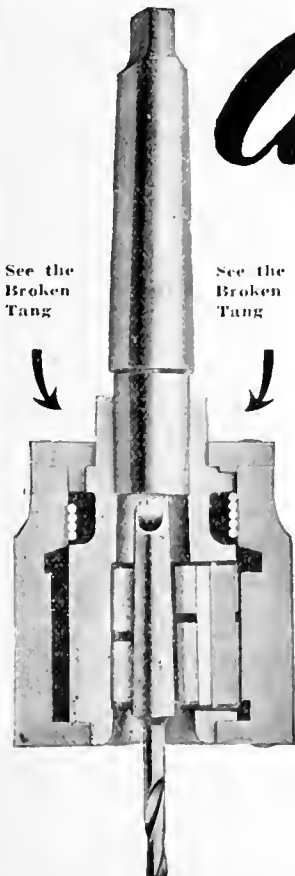

PATENT ATTORNEYS

BABCOCK & SONS

ESTAB. 1872

PATENTS-TRADE MARK-DESIGNS
IN ALL COUNTRIES

Book "Patent Protection"—free. Master of Patent Laws. Formerly Patent Office Examiner.

99 St. James St., - Montreal, Que.
Branches: Ottawa, Washington.

RESEARCH BUREAU

REPORTS BY EXPERTS ON SCIENTIFIC, TECHNICAL AND INDUSTRIAL DEVELOPMENT.

SPECIAL RESEARCHES ARRANGED.

PATENTS, TRADE MARKS, ETC.

HANBURY A. BUDDEN CABLE ADDRESS
712 DRUMMOND BLDG., MONTREAL "BREVET"

PATENTS

Folherstonhaugh & Co.
Patent Solicitors, Head Office,
Royal Bank Bldg., Toronto,
Ottawa Office, 5 Elgin St.
Send for our Plain Practical
Pointers. Copy of National
Progress, in which our patents
are advertised, mailed free.

PATENTS PROMPTLY SECURED

In all countries. Ask for our Investor's Adviser, which will be sent free.

MARION & MARION, 364 University St.
Merchants Bank Building, corner
St. Catherine St., MONTREAL, Phone Up. 6474
and Washington, D.C., U.S.A.

SPECIAL MACHINERY

GAUGES, FIXTURES, DIES
AND
PRECISION TOOLS

WE HAVE THE
MOST MODERN
EQUIPMENT
TO HANDLE
ANY CLASS OF WORK

CANADIAN DISTRIBUTORS FOR THE
**ALBANY PATENT ROTARY
PUMP**

Albany Pump Co.

16 Pearl St., TORONTO, Canada
Phone Ad. 2511 A. W. Bennet, Manager

loss, including building, plant and vegetables, is estimated at \$300,000. The buildings burned were insured for \$18,500, the machinery for \$89,500, and there was \$100,000 insurance on a large quantity of canned goods.

ELECTRICAL

Hamilton, Ont.—The Wentworth County Council will secure an estimate from the City Council on the cost of lighting several country roads for a distance of half a mile from the city.

Hamilton, Ont.—The Hydro Department will be asked for estimates for lighting for the various highway approaches to the city for a distance of half a mile from the limits.

Yarmouth, Ont.—A resolution has been passed authorizing the Hydro-Electric Commission to prepare an estimate of the cost of installing an electric service in the Township of Yarmouth, between the City of St. Thomas and the Village of Belmont.

Toronto, Ont.—The Hydro-Electric Commission contemplate a further development of 1,500 h.p. at Eugenia Falls and 2,000 h.p. at Big Chute. The proposed expenditure for Eugenia Falls extension is placed at \$217,897, and that for the Severn River extension \$121,238.

MUNICIPAL

St. Mary's, Ont.—The Town Council contemplate an expenditure of \$6,000 on improvements to the civic power plant.

Listowel, Ont.—The by-law was carried to grant a loan of \$15,000 to assist the Perfect Knit Mills, Ltd., to erect a spinning mill.

Saanich, B.C.—The City Council are considering the question of purchasing a motor chemical engine for the fire department.

Amherstburg, Ont.—The Town Council has accepted an offer from the Brunner-Mond Co. of Canada to build for Amherstburg a new waterworks plant.

Tillsonburg, Ont.—Two more industrial propositions have been presented to the Town Council, and both favorably received. A resolution was passed by the businessmen present recommending the council to give them favorable consideration.

Sudbury, Ont.—A by-law will be submitted to the ratepayers on April 30 to authorize an expenditure of \$46,000 for a stand pipe and auxiliary main, and \$2,500 for alterations to lake sewer pumping station. W. J. Ross, town clerk.

Montreal, Que.—Only six tenders were received by the Board of Control for the supply of street cleaning equipment. The firms who submitted bids are the Comet Motor Co., A. Jennings & Co., Peerless Motor Sales, General Supply Co., of Canada, Victor Levesque, and the Tiffen Truck Co.

Smiths Fall, Ont.—G. A. Burgess, of Carlton Place, Ont., has submitted a proposition to the Town Council to supply cheap power, providing he is given

permission to erect transmission lines in the town. Mr. Burgess estimates that he has for sale over 4,000 h.p., at present undeveloped at Rose Bank and High Falls.

TENDERS

Yorkton, Sask.—Tenders will be received until April 30 for one 350-400 h.p., combined Diesel electric unit. Specifications may be obtained from F. J. Pilkington, town clerk.

Adamsville, Que.—Tenders will be received up to May 1 for construction of a steel bridge, one span 125 feet, and abutments for same. Plans and specifications can be obtained from O. Landry, Sec.-Treasurer, Adamsville.

Montreal South, Que.—Tenders will be called some time in April for a 30-h.p. motor-driven turbine pump and a 150-h.p. gasoline engine-driven turbine pump for fire purposes, etc. E. Drinkwater, St. Lambert, Que., is the engineer.

Edmonton, Alta.—Tenders will be received up to May 1 for the supply of automobile markers for the Province of Alberta, during the year 1918. Specifications may be obtained on application to the Deputy Provincial Secretary, Edmonton, Alta.

Sherbrooke, Que.—Tenders are being called for 30 miles of copper wire, six transformers and other material for a transmission line to Two Mills Falls power plant. Full information may be obtained from J. R. McGregor, electrical superintendent, Sherbrooke.

Hamilton, Ont.—Tenders will be received up to Wednesday, April 18, for supplying the City Corporation with 400 feet of ¾-inch chemical fire engine hose and with 1,000 feet of 2½-inch cotton rubber-lined fire engine hose, according to specifications prepared by the Chief of the Fire Department, copies of which may be had on application at his office.

Winnipeg, Man.—Tenders addressed to the Commissioners of the Greater Winnipeg Water District will be received up to April 16, for the supply of miscellaneous bronze castings, brass piping, etc., which enter into the construction of a Venturi meter. Specifications and form of tender may be obtained at the offices of the district, 501 Tribune Building, Winnipeg.

Winnipeg, Man.—Tenders addressed to R. D. Waugh, chairman of the Commissioners, Greater Winnipeg Water District, up to April 16, for the supply of approximately 12,000 feet of 48-inch and 1,300 feet of 60-inch cast iron pipes, together with numerous specials and gate valves. Specifications may be obtained upon application to the offices of the District, 501 Tribune Bldg., Winnipeg.

Winnipeg, Man.—Tenders, addressed to the chairman, Greater Winnipeg Water District Commission, at 501 Tribune Building, Winnipeg, will be received up to April 16, for the supply of one second-hand passenger coach, also one second-hand caboose, both standard gauge. Tenderers to supply own speci-

Steel Tank 10 ft. x 8 ft. ALL WELDED

BY THE
OXY-ACETYLENE
Welding Process

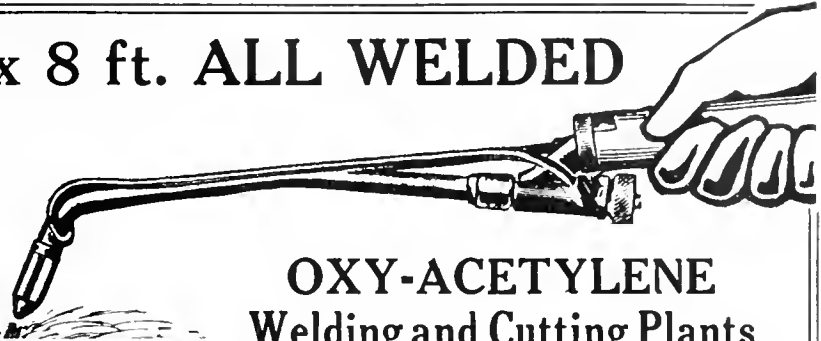
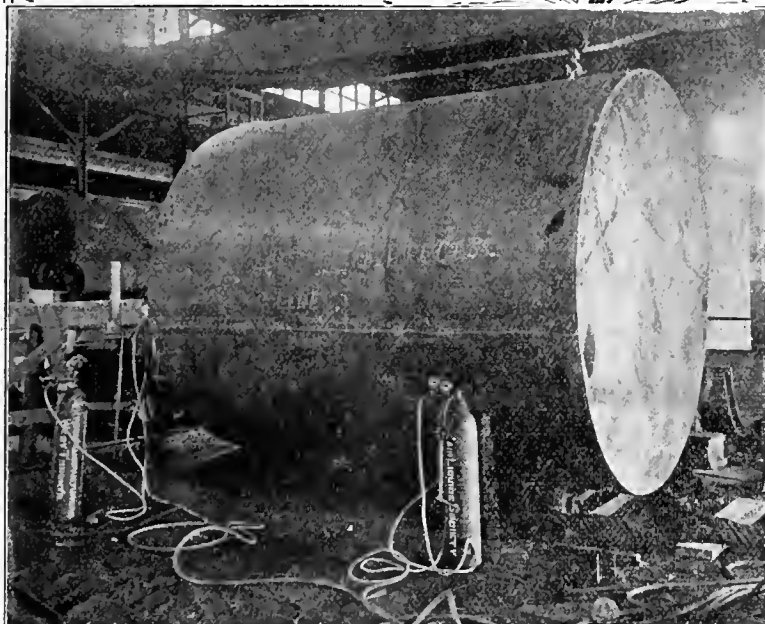

OXY-ACETYLENE Welding and Cutting Plants

Can be applied very profitably for manufacturing of tanks, boilers, etc., and repairing.

"Claude" Oxygen—made from liquid air. The most efficient—absolutely sold in purest form—full measure—at low price.

We also supply PURE DISSOLVED ACETYLENE.

L'AIR LIQUIDE SOCIETY

—Three Canadian Distributing Stations—
26 Boler St. Maisonneuve 325 William Ave
WEST TORONTO MONTREAL WINNIPEG
—Branches the World Over—

SEND COUPON FOR FULL INFORMATION.

L'Air Liquide Society, Maisonneuve,
MONTREAL, P.Q.

Gentlemen,—Will you please send, without obligation to me, postpaid, your New Booklet?

Name

Address

Province Date

Business

A Salesman Always on the Job

IT is the constant dropping that wears the stone away. It is the constant knocking at the door of attention and favor that in the end gives you ready access to the good-will of buyers of your merchandise.

You can keep up a constant knocking—a bid for attention, a reminder of yourself, a spokesman of your message—this by using regularly

The FARMER'S MAGAZINE

No man whose customers and should-be customers are farmers should be absent from their attention. Their will and purpose to buy may mature at any time. The salesman on the spot stands the best chance to get the order.

All this you know, but—do you live up to the behest of your knowledge?

Let us tell you more about The Farmer's Magazine in a special letter.

N.B.—Objectionable advertising not accepted. Both editorial and advertising columns are closely censored to keep them clean and decent.

Published by

The MacLean Publishing Co., Limited
143-153 University Avenue, Toronto, Ontario



"Barnes-made" SPRINGS

are the result of over sixty years' experience in spring making, combined with unsurpassed equipment and the workmanship of men who have been with us, ten, twenty and in some cases thirty years.

Write for booklet No. 7-T.

Established 1852.

THE WALLACE BARNES COMPANY

218 South St., Bristol, Ct., U.S.A.

Makers of "Barnes-made" Products
Springs, Screw Machine Products, Cold Rolled Steel and Wire

THE IRON WORKS LIMITED

Successors to

Owen Sound Iron Works

Owen Sound, Ont.

Engineers

Boiler-makers

Founders

Machinists

Tank Work
Smoke Stacks,
Grey Iron and
Brass Castings,
Special
Machinery
Made to
Order

METAL STAMPINGS

We are manufacturers of stamped parts for other manufacturers.

We do any kind of sheet metal stamping that you require. Our improved presses and plating plant enable us to produce the finest quality of work in a surprisingly short time.

We can finish steel stamping in Nickel, Brass or Copper.

Send us a sample order.

W. H. BANFIELD & SONS

372 Pape Avenue, Toronto, Can.

Kindly mention this paper when writing the advertiser.

"PURO - FY"

(MADE IN CANADA)

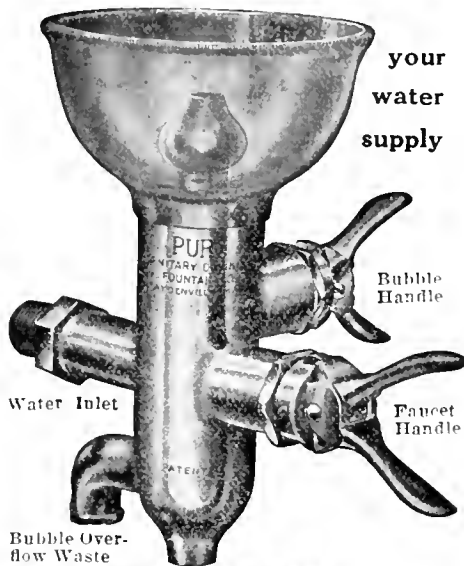

THE American Museum of Safety conferred a Gold Medal Award upon the Puro Sanitary Drinking Fountain at the First International Exposition of Safety and Sanitation. The Puro Sanitary Drinking Fountain won because it deserved to win—Puro had merits that made it stand head and shoulders above any other drinking apparatus.

Safe **Simple**
SANITARY **Economical**
Quickly Attached

These are the qualities that forced the leading safety and sanitary engineers to pick Puro in preference to all others.

No device can be as efficient that does not contain all these qualifications; and Puro was not tied for first place; Puro was first. Don't be satisfied with half-way goodness, or makeshift drinking arrangements for your employees.

If the men in your factory must drink, give them a clean drink.

Puro is clean—it does not rust or corrode. Puro is economical. It allows just the proper amount of cool, clean, fresh water to come through the bubbler. No spurting, no overflowing, no loss. Puro regulates itself. You can attach it in five minutes.

Tell us how many men in your factory and your water pressure in pounds—

We'll tell you just what it will cost to "PURO-FY" YOUR WATER SUPPLY.

PURO SANITARY DRINKING FOUNTAIN

TRADE MARK

147 University Ave. TORONTO, ONT.



Let CANADIAN
MACHINERY Sell
It for You.

fications. Further particular on application to undersigned, R. D. Waugh, chairman of Commissioners.

Drummondville, Que.—Tenders will be received until April 20 for drilling wells and supplying pumping equipment.

Winnipeg, Man.—Tenders, addressed to the Chairman, Board of Control, will be received up to April 16, for the supply of labor and materials required in the erection of a 150-foot brick or concrete chimney for the Elmwood Incinerator. Plans, specification and form of tender may be obtained at the office of the City Engineer, 223 James Avenue.

Ottawa, Ont.—Tenders will be received until April 21 for steam boilers and stokers required for the Central Heating Plant for the Parliament Buildings. All tenders to be based on the supplying and erecting of three water tube boilers, each having a rated capacity of 500 horse-power, together with fittings and soot blowers. Each tender shall give separate quotations for supplying and erecting, in connection with boilers, three automatic stokers. One boiler and stoker shall be erected complete within five months after date of awarding contract and the other two shall be erected before January 1st, 1918. Plans, specifications and any other information required can be obtained at the office of the general contractor, P. Lyall & Sons Construction Co., Ltd., Ottawa.

PERSONAL

Lieut.-Col. Wood Leonard, D.S.O., of London, Ont., was killed in action recently in France, while in command of the 3rd Artillery Brigade. Col. Leonard was a son of Frank E. Leonard, and was associated with his father and brothers in the firm of Leonard & Sons, the well known engineers of London, Ont. He was a graduate of the Royal Military College, Kingston, Ont., and went overseas in 1914 in command of the 6th Field Battery. Col. Leonard was 34 years of age.

Prof. John C. McLennan has been appointed to the British Board of Inventions and Research, under the chairmanship of Sir John Fisher. Prof. McLennan is head of the Department of Physics of the University of Toronto, having been connected with the institution since 1892. He will probably occupy the post for the summer, and will leave shortly.

Henry A. Everett, at one time a prominent street railway magnate of Cleveland, O., died at Pasadena, Cal., on April 11, aged 60. He was formerly president of the Cleveland Railway Co., the Toledo Railways and Light Co., and London Street Railway Co., London, Ont., electrical engineer of the Montreal Street Railway, and was financially interested in many electric traction companies in Canada and United States.

Sir Lyman Melvin Jones, president of the Massey-Harris Co., died in Toronto last Monday after an illness of two months' duration. The late Sir Lyman was a native of York County, and was born in 1843. His first real employment

was as a young man with the firm of A. Harris, Son & Co., Brantford, Ont., and while still in his twenties was admitted as a partner. In 1879 he was sent to Winnipeg as Western manager, and later was made general manager. The formation of the Massey-Harris Co. in 1891 brought him to Toronto as general manager of the consolidation. He became president as well in 1902, and held that post until his death. He was also president of the Bain Wagon Co., Woodstock, Ont., and the Johnston Harvester Co., Batavia, N.Y. The deceased was called to the Senate in 1901, and ten years later knighted by King George.

TRADE GOSSIP

The Coleman Fare Box Co. has removed its plant from Tottenham, Ont., where the business was founded, to 1191 Bathurst Street, Toronto.

Will Develop Peat Lands.—The Prince Edward Island Provincial Legislature has under consideration a bill to develop plant lands. Tests will be made to determine its suitability for fuel.

The Phoenix Bridge & Iron Works, Montreal, have been awarded the contract for the steel bridge across St. Francis River for the municipalities of East Angus and Westbury, Que. Contract price \$45,000.

Galt, Ont.—The Canadian Brass Mfg. Co., has acquired the B.O.T. Mfg. Co. of Toronto, established in 1910. The head office will be at Galt and the Toronto office becomes a branch. G. A. Dobbie, of Galt, is president.

The Multisize Rotary Press Co., 19 Charlotte Street, Toronto, A. C. Ransom, president, are installing a machine shop at the above address to take care of machine work in connection with printing presses which they are now building.

Railway Board Suspends Tariff.—The Dominion Railway Commission has suspended the operation of the new lake and rail tariff of the railways between points East and West. There have been many protests against the increase of the rates as "unjustifiable," and because of the lack of notice; and the case will be argued on the merits, the old rates applying meanwhile. The companies have based their claims largely on the scarcity of tonnage, due to the transfer of lake boats to ocean services.

Welland Industries Grow.—The annual report of L. B. Duff, Industrial Commissioner of Welland, Ont., for 1916, shows an industrial growth in Welland of almost incredible proportions. The value of manufactured products was \$19,375,115, an increase of more than six millions over 1915, and thirteen millions over 1912. The advance is not confined to munitions, the value of munitions output not exceeding five and a half millions of the total. The pay roll totalled \$3,610,336. The increase in the rate of pay is shown by the fact that the number of industrial workers was 4,890, as compared with 3,000 in 1912. A million and a half was spent on enlargement of plants.

CANADIAN MACHINERY AND MANUFACTURING NEWS

A weekly newspaper devoted to the machinery and manufacturing interests.

Vol. XVII.

TORONTO, APRIL 26, 1917

No. 17

EDITORIAL CONTENTS

Equipment, Methods and Devices for Producing 9.2 ins. Shell	415-422
General	422
Grinding of Tapers....Workmen's Compensation Board Report....Imperial Munitions Board Orders....Loan to Assist Shipbuilding.	
Production Methods and Devices	423-426
Hand Sizing Counterbore for 8-inch Adapters...Reseating Reamer for Fuse SeatsAn Interesting Shell Gauge....Why a Pattern is Divided....Coatings for Wood Patterns....Adapting Gasoline Engines to Burn Kerosene....Saving Time on Screw Machine Work....Re-Tapping Shrapnel Sockets....Women and MunitionsDies for Steel Pilot Fender Rails.	
General	426
Developing Our Latent Wealth.	
Tool Holder and Cutting Tool Application Data—II	427-428
Spokes in Industry's Wheel	429
R. M. McCleery.	
Worm Gear Design Features and Worm Gear Mounting Detail	430-433
Progress in New Equipment	431-436
Boss Lock Nut Safety Factor....Friction Headstock Lathe....Shell Base Facing Machine....Heavy Duty Precision Drilling Machine.	
General	436
Fellowship for Research Work....Our Present Prosperity Due to Steel.	
Editorial	437
Objective of Munitions Scrap Conservation....Coal Will Continue Scarce and Dear.	
Selected Market Quotations	438-439
The General Market Condition and Tendency	439-442
Summary....Montreal Letter....Toronto Letter....Sydney Letter.	
Industrial and Construction News (Advtg. Section)	64-71

THE MACLEAN PUBLISHING COMPANY, LIMITED

JOHN BAYNE MACLEAN, Pres. H. T. HUNTER, Vice-pres. H. V. TYRRELL, Gen. Man.

Publishers of Hardware and Metal, The Financial Post, MacLean's Magazine, Farmer's Magazine, Canadian Grocer, Dry Goods Review, Men's Wear Review, Printer and Publisher, Bookseller and Stationer, Canadian Machinery and Manufacturing News, The Power House, The Sanitary Engineer, Canadian Foundryman, Marine Engineering of Canada.

Cable Address: Macpubco, Toronto; Atabek, London, Eng.

ESTABLISHED 1887.

CANADIAN MACHINERY AND MANUFACTURING NEWS

PETER BAIN, M.E., Editor. B. G. NEWTON, Manager.
Associate Editors: A. G. WEBSTER, J. M. WILSON, J. H. RODGERS.

CHIEF OFFICES:

CANADA—Montreal, Southam Building, 128 Bleury Street; Toronto, 143-153 University Ave., Telephone Main 7324. Winnipeg, 22 Royal Bank Building, Telephone Garry 2313.

GREAT BRITAIN—LONDON, The MacLean Company of Great Britain, Limited, 88 Fleet Street, E.C., E. J. Dodd, Director. Telephone Central 12960. Cable Address: Atabek, London, England.

UNITED STATES—New York, R. B. Huestis, 115 Broadway, N.Y., Telephone Rector 8971; Boston, C. L. Morton, Room, 733, Old South Building, Telephone Main 1201. A. H. Byrne, 1104 5-6-7 Fort Dearborn Bldg., 105 W. Monroe St., Chicago, Telephone Randolph 2234.

SUBSCRIPTION PRICE—Canada, Great Britain, South Africa and the West Indies, \$3.00 a year; United States, \$3.50 a year; other countries, \$4.00 a year; Single Copies, 15 cents. Invariably in advance.

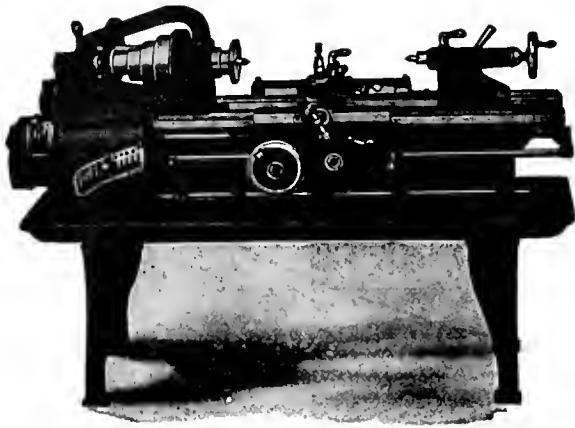

The "HENDEY" Lathe

The Service

Capacity and Convenience

of a Hendey Lathe will prove of vital importance to your tool room.

The "Hendey" is accurate in the highest degree and suited for the efficient use of watch tool chucks, stop chucks, relieving attachments, etc.

It has the best spindle construction in its taper journals, with annular bearings and automatic oiling rings, which make for accuracy of alignment.

It has **automatic stop** for carriage working in either direction. Has reverse for carriage, controlled from apron.

Wide range of threads and feeds through mounted gearing, with ability to make gear changes for additional threads and feeds without limit.

A card will get you full particulars. Why not mail it now?

THE HENDEY MACHINE COMPANY TORRINGTON, CONN., U.S.A.

Canadian Agents: A. R. Williams Machinery Co., Toronto, Ont.; A. R. Williams Machinery Co., 260 Princess St., Winnipeg; A. R. Williams Machinery Co., Vancouver; A. R. Williams Machinery Co., St. John, N.B.; Williams & Wilson, Montreal.

INDEX TO ADVERTISERS

Adams, Ogden R.	109	Cummings & Son, Ltd., J. W.	92	Jones & Glasco	160	Pritchard-Andrews Co., of Ottawa ..	93
Albany Pump Co.	68	Curtis & Curtis Co.	86	Kennedy, Wm., & Sons	16	Puro Sanitary Drink'g Fountain Co. .	70
Armstrong Bros. Tool Co.	92	Cushman Chuck Co.	107	Ker & Goodwin	69	Racine Tool & Machine Co.	27
Armstrong, Whitworth of Canada ...	14	Davis-Bourmonville Co.	178	Keystone Mfg. Co.	90	Rhodes Mfg. Co.	89
A. S. K. Chemical Co.	69	Davis, W. F., Machine Tool Co.	78	King, Ltd., Wardeo	22	Riverside Machy, Depot	73
Atkins, Wm., & Co., Ltd.	14	Deloro Smelting & Refining Co.	4	L'Air Liquid Society	83	Rivett Lathe & Grinder Co.	125
Atlas Crucible Steel Co.	14	Delta File Works	69	Lambis Machine Co.	26	Rockwell Co., W. S.	110
Atlas Press Co.	109	De Mooy Mach. Co.	113	Lancashire Dynamo & Motor Co. ...	30	Rodolofson Machine & Tool Co.	119
Babeock & Sons	68	Dickow, Fred. C.	67	Latrobe Electric Steel Co.	9	Roper & Co., C. F.	97
Baird Machine Co.	110	Dominion Belting Co., Ltd.	61	London Bolt & Hinge Co.	67	Scott, F. H.	78
Banfield, E. J.	16	Dominion Bridge Co.	109	Mackinnon, Holmes & Co., Ltd.	71	Sheldons, Ltd.	95
Banfield, W. H., & Sons	69	Dominion Machinery Co.	76	Magnolia Metal Co.	98	Shuster Co., F. B.	169
Barnes, Wallace, Co.	71	Dominion Steel Foundry Co.	107	Marion & Marion	62	Silver Mfg. Co.	169
Bath, Cyril J.	74	Drury Co., H. A.	7	Manufacturers Equipment Co.	108	Skinner Chuck Co.	107
Baxter & Co., Ltd., J. R.	15	Eastern Mach. Screw Corp.	104	Marsh & Henthorn, Ltd.	94	Sloeman, Avram & Slocum	117
Bemis & Call Hardware & Tool Co. .	91	Elmes, Chas. F.	94	Matthews, Jas. H., & Co., Inc.	32	Smalley-General Co.	89
Bernard Industrial Co., A.	59	Erie Foundry Co.	95	McCabe, J. J.	24, 78	Smooth-On Mfg. Co.	121
Bertram, John, & Sons Co., Ltd.	1	Fairley, Davidson Steel Co.	10	McCoy-Brandt Machy. Co.	74	Standard Mfg. Co.	10
Front cover and page 1		Fetherstonhaugh & Co.	10	McDouglall Co., H.	Inside back cover	Standard Alloys Co.	11
Bertram's, Limited	67	Fitzgerald, W. H. J.	68	McKenzie, The D. K., Machy. Co.	25	Starrett Co., L. S.	111
Blake & Johnson Co.	121	Flock, Alexander, Limited	73	McLaren, J. C., Belting Co.	108	Steel Bending Brake Works, Ltd.	108
Bliss, E. W., Co.	95	Ford Chain Block & Mfg. Co.	100	Mechanical Engineering Co.	87	Steele, Ltd., James	65
Blount, J. G.	15	Fess & Hill Machy. Co.	100	Metalwood Mfg. Co.	35	Stetcher Co., Chas.	25
Brantford Ordn & Rack Co.	71	Inside back cover		Michigan Steel Exchange, Inc.	34	Steel Co. of Canada	3
Bridgeford Mach' Tool Works	9	Francis & Co.	109	Miller Smythe Electric Co.	75	Steptoe, John, Co.	82
Bristol Company	177	Gardner Machine Co.	119	Milhilland Co., W. K.	73	Stirk & Sons, John	67
Brown Engineering Corp.	81	Gardner, Robt., & Sons	79	Modern Machy. Exchange	163	Stocker-Rumley-Wachs Co.	11
Brownell Machy. Co.	78	Garlock-Walker Machy. Co.	21	Modern Tool Co.	79	Stow Mfg. Co.	18
Brown's Copper & Brass Rolling Mills	85	Garvin Machine Co.	63	Monarch Brass Mfg. Co.	79	Swedish Steel & Importing Co.	25
Buden, Hanbury A.	68	Geometric Tool Co.	86	Montgomery Smith & Co.	87	T. C. M. Mfg. Co.	86
Can. Bond Hanger & Coupling Co.	99	Gibb Instrument Co.	108	Montreal General Tool Co.	20	Tallman Brass & Metal Co.	117
Canada Machinery Corporation	Outside back cover	Grant Gear Works, Inc.	96	Montreal Machy. & Supplies	115	Taylor Instrument Co.	85
Canada Sales Co.	82	Grant Mfg. & Machine Co.	92	Morse Twist Drill & Mach. Co.	111	Toledo Machine & Tool Co.	95
Can. B. K. Morton Co.	6	Greenfield Machine Co.	108	Morse Chain Co.	101	Toomey, Frank A.	76
Can. Fairbanks-Morse Co.	34	Hall & Sons, J. H.	29	Morton Mfg. Co.	71	Toronto Iron Works	107
Can. Billings & Spencer	96	Hammond Car & Engine Works	96	Muir, Wm., & Co.	67	Toronto Testing Lab.	110
Can. Blower & Forge Co., Ltd.	61	Hamilton Gear & Machine Co.	28	Murphy Machine & Tool Co.	165	Toronto Tool Co.	71
Can. Desmond-Stephan Mfg. Co.	104	Hamilton Machine Tool Works	23	National Machinery Co.	78	Toronto Welding Co.	98
Can. Economic Lubricant Co.	97	Hanna & Co., M. A.	15	National Machine Tool Co.	119	Trihern Pump Co.	78
Can. Ingersoll-Rand Co., Ltd.	121	Hardinge Bros.	22	New York Machinery Exchange	75	Union Drawn Steel Co.	149
Can. Inspection & Testing Laborator-ies, Ltd.	157	Hawkridge Bros.	71	Nicholson Co.	91	Vanadium Alloys Steel	12
Can. Mathews Gravity Carrier Co.	69	Hendley Machine Co.	128	Niles-Rement-Pond, L.	Inside front cover	Victor Saw Works	28
Can. Metal Products	82	Hepburn, John T.	18	Northern Crane Works	107	Vulcan Crucible Steel Co.	9
Can. Morehead Mfg. Co.	31	High Speed Hammer Co.	93	Norton, A. O.	168	Walcott Lathe Co.	18
Can. Steel Foundries, Ltd.	7	Himoff Mach. Co.	198	Norton Co.	34	Warner & Swasey Co.	21
Can. S. K. P. Co., Ltd.	33	Hoit Metal Co.	110	Nova Scotia Steel & Coal Co.	112	Webber Bros. Mach. Co.	82
Carlyle Johnson Mach. Co.	8	Hull Iron & Steel Fdries, Ltd.	125	Ontario Specialties, Ltd.	110	Wells Bros. Co. of Canada	32
Cataract Refining Co.	84	Hunter Saw & Machine Co.	25	Oven Equipment & Mfg. Co.	87	Whiting Foundry Equipment Co.	99
Chaoman Double Pall Bearing Co.	97	Hungerford Brass & Copper Co.	84	Owen Machy. Co.	18	Whitman & Barnes Mfg. Co.	110
Chesternan, Jas., & Co., Ltd.	73	Hutchinson-Rogers Machinery Co.	27	Parmenter & Bulloch Co.	108	Whitton Mach. Co., D. E.	110
Cincinnati Iron & Steel Co.	20	Hvde Engineering Works	73, 104	Parrin, Wm. R.	95	Williams, A. R., Machinery Co.	63, 73
Cincinnati Pulley Machy. Co.	115	Ideal Tool & Mfg. Co.	103	Peerless Machine Co.	27	Williams, J. H., & Co.	91
Cleveland Wire Spring Co.	17	Independent Pneumatic Tool Co.	20	Petrie, H. W., Ltd.	73	Wilson & Co., T. A.	110
Cleveland Pneumatic Tool Co.	117	Iron Works, The	70	Pleissville Foundry	67	Windsor Mach. & Tool Works	83
Clippert Belt Lacer Co.	17	Jacobs Mfg. Co.	162	Port Hope File Mfg. Co.	31	Winnipeg Gear & Engineering Co. ...	80
Colonial Steel Co.	93	Jardine Co., A. B.	113	Positive Clutch & Pulley Works	108	Worth Engineering Co.	71
Cook, Asa S.	169	Jencks Mach. Co.	9	Pratt & Whitney,	Inside front cover	Zenith Coal & Steel Products Co.	168
Cullen Machy. Co., C. W.	74	Jersey City Mach. Co.	169	Pringle, R. E. T., Ltd.	29, 31		
		Johnson Mach. Co., Carlyle	8				



Equipment, Methods and Devices for Producing 9.2 in. Shell

Staff Article

The plant here featured was organized solely for the purpose of machining 9.2 in. high explosive shell, and from a study of the nature and layout of the machine tool and other equipment as described and illustrated, it will become evident that production achievement was not only possible but certain of realization. As in numerous other instances, however, the personal element has contributed very materially to the degree of success attained.

THE manufacture of 9.2-in. high explosive howitzer shells is of special interest, in that it is the largest calibre shell being made in Canada, and also by reason of the heavy equipment required for its production. Another feature common as well to 8-in. shell, but not necessary for 4.5 in. or smaller shell is the system of hoists and runways required to facilitate handling. The forging for a 9.2 in. shell weighs approximately 387 pounds, and thus special provision has to be made for moving it from one operation to another. The illustrations accompanying this article

show this feature in its various aspects. At this plant the floor of approximately 40,000 sq. ft. was of sufficient size to permit of all the machinery, with the exception of that in the tool room, being placed in one shop, the equipment being installed so that the shells move forward all the time, for the most part on benches or runways, thus accelerating production and reducing handling to a minimum.

General Layout of Plant

The general layout of the plant may be described as follows:—The forgings are brought in on a spur from a steam

railway and deposited in piles outside the main shop and under cover. When required they are picked up by a chain hoist and brought into the main shop for the first operation, that of marking and centering the nose. Another hoist carries the forgings to a battery of drills to have the hole in the nose drilled and the nose faced up. They are then rolled along a bench to the cutting-off machines. After the open base end has been cut to an approximate length, the forgings are carried by means of a hoist to a runway extending practically three-quarters the length of the shop, and

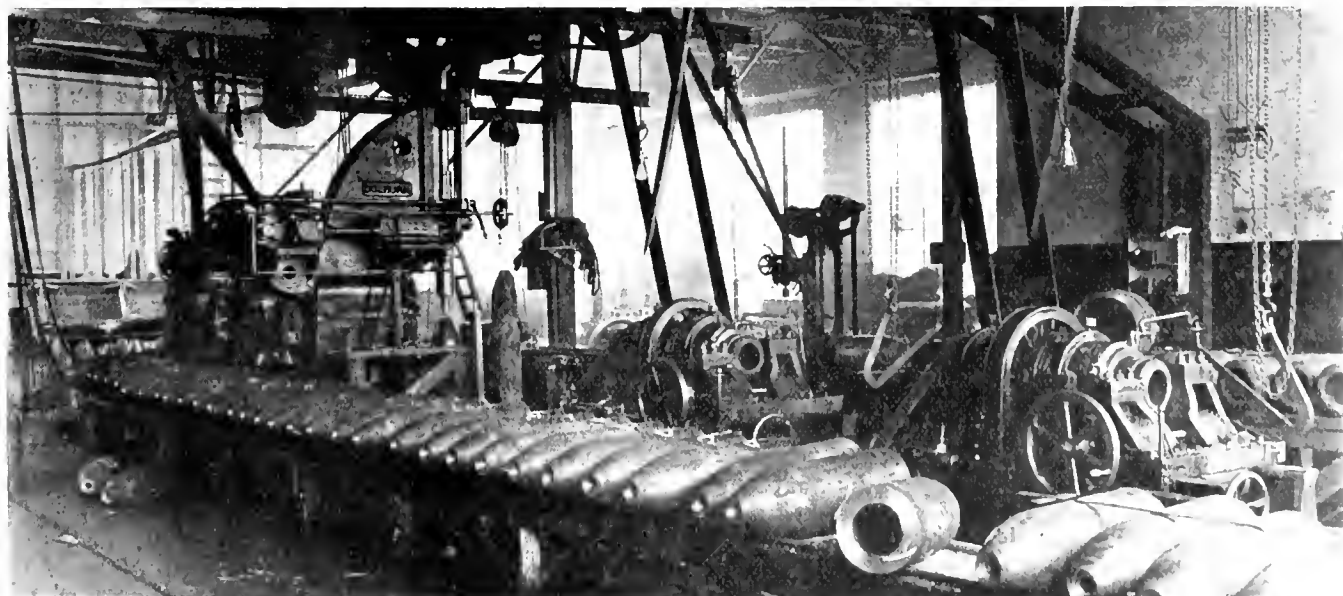

INITIAL OPERATIONS OF DRILLING AND FACING NOSE AND CUTTING-OFF OPEN BASE END FORGINGS ON RUNWAY IN FOREGROUND ARE READY FOR ROUGH TURNING

servicing half its width. Two long runways built up with cast iron legs and 6-in. I-beams, serve four rows of lathes, two on either side, with a "Wright" hand-operated chain block or hoist to each machine for lifting the shell from the runway to lathe and vice versa. On the completion of each operation the shell is rolled forward on the runway to the next lathe and so on. The operations performed in this section are in the following sequence, and take in all four rows of lathes:—Rough turning outside; boring inside; boring nose for thread; finish turning outside; counter-boring and recessing base; wave and undercut band recess; milling thread in base end; milling thread in nose end. An interesting feature in this section of the plant is the installation of 33 "Bridgeford" lathes, including twelve for rough turning, fifteen for boring, and six axle lathes for finish turning operations.

After the preliminary inspection at the end of the shop, the shells are washed to remove the grease and then rolled along a bench to have the adapters fitted. For the subsequent operations the shells move forward along the other side of the shop, being rolled along benches from one stage to another, until they arrive at the end from which they started, ready for boxing. The section of plant devoted to the manufacture of the adapters is at the farthest end from the starting point and adjoins the department where the adapters are screwed into the base. Incidentally it might be stated that the adapter is a solid steel forging which is screwed into the base of the shell. The shell has to be left open at the base to allow for machining inside. The adapter also serves another purpose of ensuring that the base is free from flaws or "pipes," thus preventing a premature explosion when the shell is being fired from the gun. A similar precaution is taken in all high explosive shells. For all machining operations in

Principal Features of 9.2-in. Shell
Before proceeding with a description of the manufacture of 9.2-in. shell a few particulars regarding the size and

ings, and the forging is then taken over on a hand truck to a vertical "Barnes" drill, where the nose is drilled and countersunk. For this operation the forging

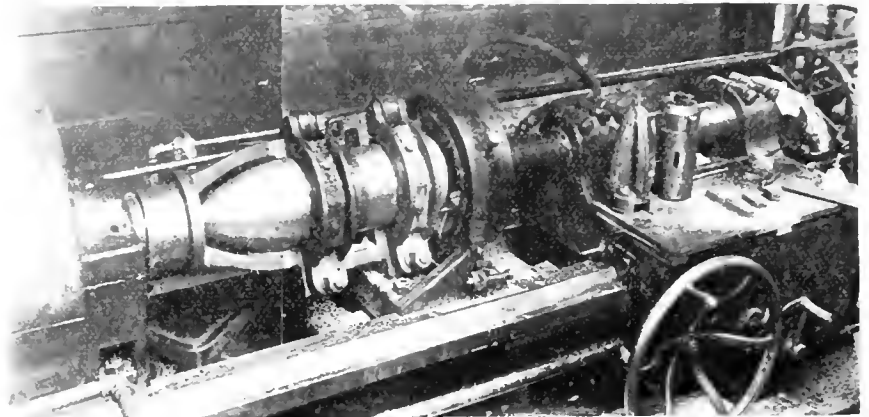

BORING ON "BRIDGEFORD" LATHE WITH "DAVIS" CUTTER HEADS ON BORING BAR.

weight may be of interest. The forging has an open base end and a conical nose, and, as already stated, weighs approximately 387 pounds. It has to be not less than 28 $\frac{3}{8}$ in. long over all, and is 10 in. outside diameter. The billet from which the forging is made weighs approximately 389 lbs., and is about 17 $\frac{3}{4}$ in. long by 9 15 16 in. in diameter. The finished shell weighs 252 lbs. 11 oz. empty, and 290 lbs. filled; the charge of explosive, T.N.T., weighing 34 lbs. The overall length without fuse is 26.83 in., the outside diameter is 9.155 in., and inside diameter 6.50 in. The adapter forging weighs about 47 lbs. All machining operations have to be very accurate, as the difference between high and low limits is very fine. In the weight of the shell plus or minus 3 lbs., 12 oz. toleration is allowed.

Centering Nose

The first thing to be done before ma-

is slipped over a post pivoted at the bottom. When the forging is on the post it is swung over into vertical position for centering.

Drilling and Facing Nose.

One "Colburn" and three "Baker" drills are installed for drilling and facing the nose. The fixture for holding the forging consists of a vertical post, with a conical head, under which is a spring. The post rests on a sliding base, which is pulled away from the drilling machine for the forging to be placed over it. The forging is lifted on to the post by a chain hoist and is then placed in position for machining. The hole is drilled first; then the drill is replaced by an end mill, which faces up the nose.

Cutting Off Base End

The forgings are removed from the drills, placed on a bench or runway, and rolled along towards the cutting-off machines for the base end to be cut off. The forging is first marked for cutting off, the distance being gauged from the face of nose. The jig used for marking off has a small punch attached to the end near the base. The operator punches a number of small holes to mark the position for cutting off. There are three cutting-off machines, supplied by the Williams Tool Co., Erie, Pa., a hoist for each being provided for lifting the shells to and from the runway. The cutting-off machines are all the same type, and are arranged in a row parallel to the runway. Each machine has two tool posts, front and back, the cutting-off tools working simultaneously.

Rough Turning Outside Body

The next operation consists of rough turning the outside of body and profile on a battery of twelve heavy duty "Bridgeford" lathes. These latter are 27 in. by 12 ft. machines, and have variable speeds and feeds. Each lathe is driven by a Positive Clutch & Pulley Co. friction clutch. They have a double carriage with independent control. Each lathe is equipped with a special roller chuck for holding the open base end.

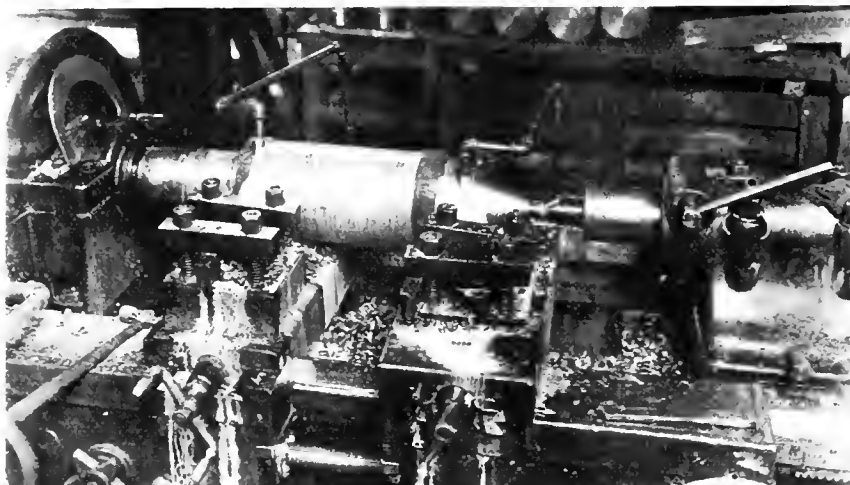

ROUGH TURNING OPERATION ON "BRIDGEFORD" LATHE.

this section of and also throughout the plant "Wright" hoists are used for handling the shells any time they have to be lifted to or from the benches. The illustrations show the system employed in handling the shells.

chining operations on the shell can be attempted is to centre the nose. The forging is first of all placed on an inclined post, the nose chalked, and four marks made with a scribing block. A small hole is punched between the mark-

There are three rollers in the chuck which automatically expand inside the shell base and hold it firm. For holding the nose end, a split expanding-bushing is used, into which is driven the centre. There are two tool posts—one tool forming the profile and the other roughing the body.

The profiling attachment consists of a slotted bar carried on brackets at the back of the lathe. Fastened in the slot is a pivot, which is connected to the cross slide by means of a radius bar. As the carriage moves forward, this bar regulates the travel of the cross slide, and also, of course, the tool post which is mounted on the cross slide. The other tool begins cutting at the shoulder of shell and travels in the same direction towards the headstock, only parallel to the shell. One roughing cut only for each tool is necessary at this operation. Production at this operation has been as high as 38 shells in ten hours. There are four rows of lathes for this operation, and "Wright" hoists are used for handling the shells.

Inside Boring

After being rough turned the shells are rolled along the runway to the next set of lathes for the inside boring operation. Fifteen "Bridgeford" boring lathes take care of this, and are installed in four rows alongside the runways with hoists for handling the shells. The lathes are of some size and general design as those already mentioned, but are equipped with a boring bar taking "Davis" boring heads. A special cradle chuck is used for holding the shell, the latter being dropped into the chuck and secured with two clamps. One end of chuck is carried on the lathe spindle,

and the base end revolves in a steady run. The "Davis" boringheads are interchangeable with male taper on the boring bar.

the bore. The arbor is secured to the lathe spindle, and is also supported at its base by a steady rest. At the front

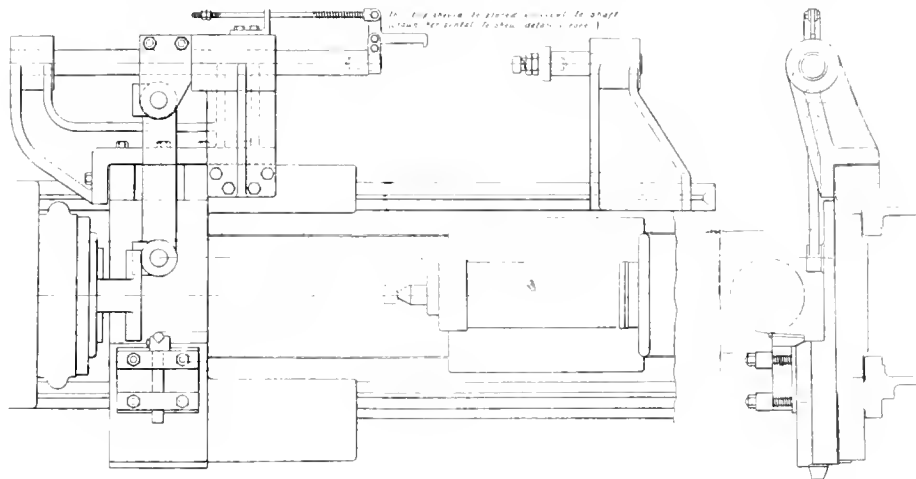

PROFILING ATTACHMENT AS FITTED TO "BRIDGEFORD" AXLE LATHES FOR FINISH TURNING OPERATION

Three boring tools are used. The first is a four-point body roughing tool, the second a four-point profile roughing tool, while the third finishes the body and profile. The lubricant enters the shell through the spindle to wash the chips out. On this operation 43 shells have been bored out in ten hours.

Boring Nose for Thread

Next in line are three Davenport 2 1/2 in. x 10 ft. engine lathes for machining the nose preparatory to threading. The nose is not threaded at this operation, being done later on a thread miller. An expanding arbor is used for holding the shell, as the nose must be in line with

end of the arbor are three projections or studs which centre the shell and, at the same time, expand inside it, holding the shell firm. The base of shell rests on a taper bearing at the base of arbor, which also aids in keeping the shell concentric. The lathes are equipped with a "Phoenix" turret attachment, having four tools. The first is a "Davis" boring tool with two cutters which bore out the hole in nose right through. The second tool bores the hole for the threads as far as the retainer seat, while in the third turret face is a bar with a recessing tool. This tool forms the recess for the threads to finish in, and is 1.2 inches from the nose. The fourth tool is a

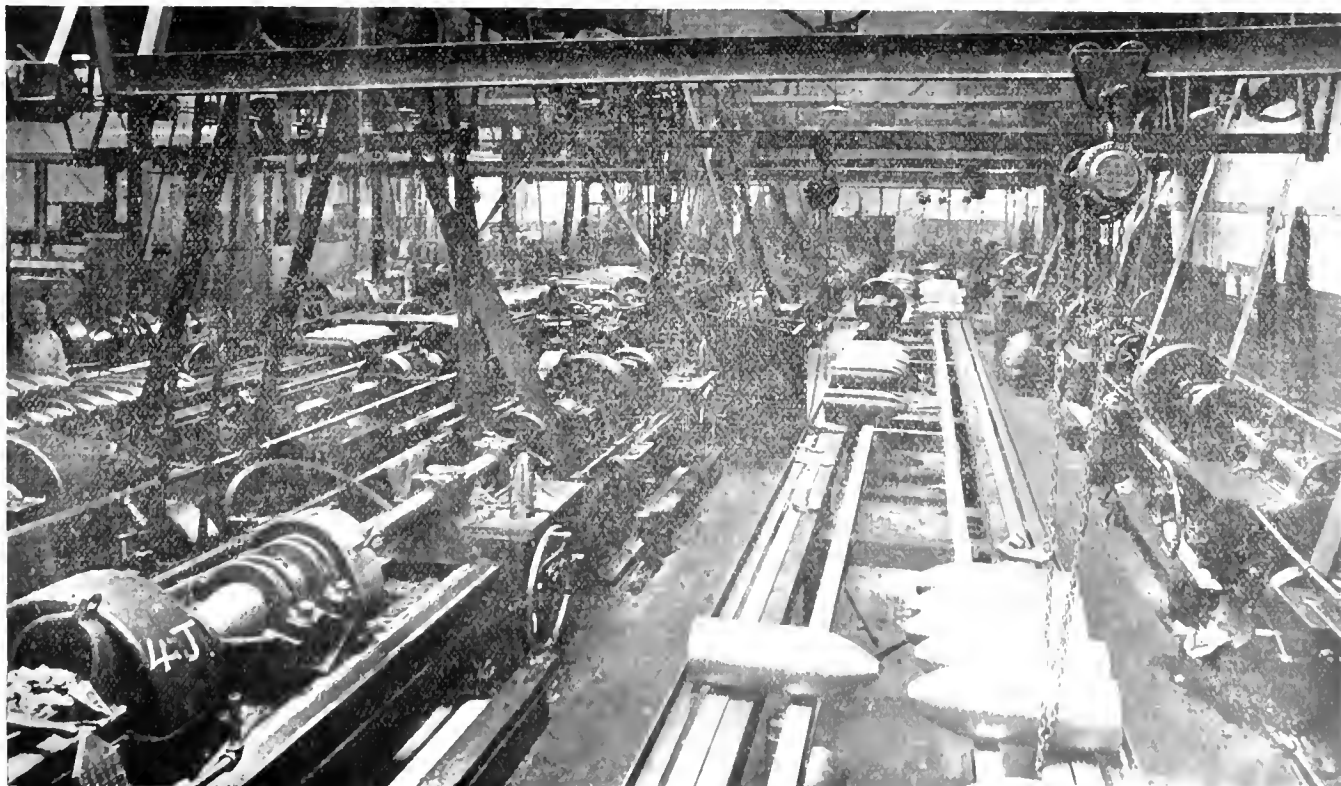

GENERAL VIEW OF "BRIDGEFORD" LATHES ON ROUGH TURNING AND BORING OPERATION—ALSO ARRANGEMENT OF RUNWAYS AND WRIGHT HOISTS FOR EACH LATHE

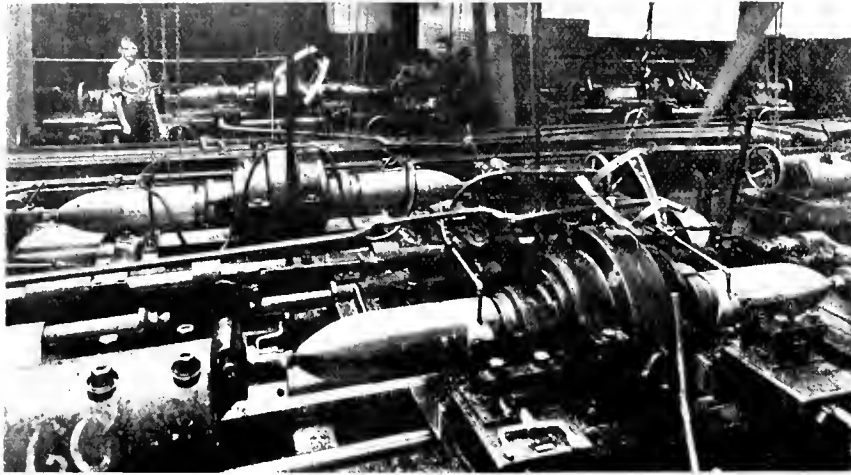

FINISH TURNING OUTSIDE BODY AND PROFILE ON "BRIDGEFORD" AXLE LATHE.

nose reamer which chamfers the nose and forms a bevel for fuse seat. The nose is now ready for threading.

Outside Finish Turning

At this operation the shell body is finish turned outside, including the profile. "Bridgeford" axle lathes are used for the work, there being altogether six of them installed on either side of the runways and in line with the lathes referred to in the preceding operations. They have a centre drive with a chuck on either side of the drive head, the expanding roller chucks being of same type as were used for rough turning. Two shells can thus be turned on one lathe. When chucking the shell for this operation, a fixture is used to ensure the profile being true. In the early days it was found that if the base of shell came up against the chuck face it had a tendency, in some cases, to throw the profile out, as the base at this stage of manufacture is not always square with the side. To obviate any trouble in this regard, a length gauge is put inside the shell right up to the nose, the other end of gauge resting on the chuck face when the shell is being turned. The face of

shell base is thus free. A split bushing and centre is driven in the nose as is done at the rough turning operation.

the profile and the parallel part of shell. The turning tool has a semi-circular cutting edge which has been found to be the most suitable shape for profiling.

The profiling attachment is carried in brackets at the rear of the lathe, each side having a separate profiler. The brackets carry a 2 15/16 in. shaft with a clamp attached acting as a pivot for the radius bar which connects with the cross slide carrying the tool post. The tool starts cutting at the base end of shell and travels forward parallel to the shell up to the shoulder. During this time the carriage and profile attachment travel along together until the bar at the back comes up to a stop. When this bar hits the stop, profiling begins. The clamp being fixed to the bar remains stationary against the stop and therefore draws the tool post by means of the radius bar, thus forming the profile. This profiling attachment was designed at the plant

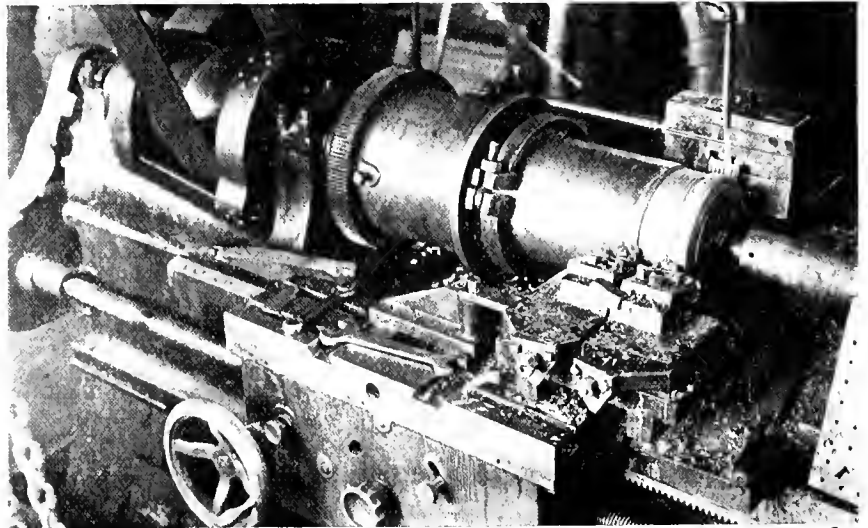

WAVING AND UNDERCUTTING- GRAY MFG. & MACHINE CO. ATTACHMENT.

There is only one tool post on each side of lathe, a specially designed profiling attachment enables one tool to turn both

and is shown in the line drawing. It is a comparatively simple device, but it has proved very satisfactory. Before the shell is removed from the lathe, the carriage is moved back to the base end, and that part of the shell body behind where the copper band will be, is finish turned to a shade smaller diameter than the rest of the body. The corner at base is also turned off, forming a bevel. The shell is then lifted out of the lathe by a chain hoist and rolled along the runway for the next operation.

Counter Boring and Recessing Base, Rough Turning Copper Band Groove

This series of operations follows, the first of them being done in "Le Blond" lathes equipped with a turret attachment. The shell is held in a box chuck, while a steady rest supports the base end. The first tool in the turret faces up the base end; then follows the second tool which rough counterbores inside the base, while the third tool finishes the counter bore. The fourth forms the bevel on base on the outside edge. There are two diameters in the counter bore, the first, nearest the outside, is .62 ins. deep and 7 ins. in diameter, and takes



SCREWING ADAPTER IN SHELL BASE, SHOWING ALSO, IN FOREGROUND, FINISHED ADAPTER AND OPEN END OF SHELL READY TO RECEIVE IT.

the flange of the adapter. The second, for the threads, is 2.3 ins. deep and 6.49 ins. in diameter before threading. The finished length for facing up the base end is corrected by a bar gauge.

Rough turning or hogging the copper band groove is really a minor operation and is done to relieve the tools when waving and undercutting. Three "Le Blond" engine lathes are used with an ordinary side tool post. The shell is held in the lathe by a split bushing centre at the nose end while a circular centre plate is driven into the base end. A roughing cut is taken to remove superfluous metal before waving.

Waving and Undercutting

In the 9.2 ins. shell there are 7 waved ribs, and the groove is approximately 2.7 ins. wide. Three engine lathes are employed all equipped with a waving attachment made by the Gray Mfg. & Machine Co., Toronto. The nose of the shell is held in a pot chuck with a driving clamp, while a circular plate centre is fitted in the base end. It will be noticed from the illustration that the undercutting tools are at the front and the waving fixture is at the back. The waving motion is obtained by means of a cam inside the fixture, driven by compounded gears from the large gear on the main spindle. The feeding is done by a bar cam in the fixture. The diagonal feed for the undercutting tools is obtained by using a cam bar, the end of which will be seen outside the fixture, to the left. The waving and undercutting is done simultaneously.

Milling Thread in Base and Nose

The threads in both the base and nose are milled. The machines used for both operations are "Holden-Morgan" thread millers. There are five of these machines installed for milling the base threads and two for nose threads. The machines for both operations are essentially the same, and are standard

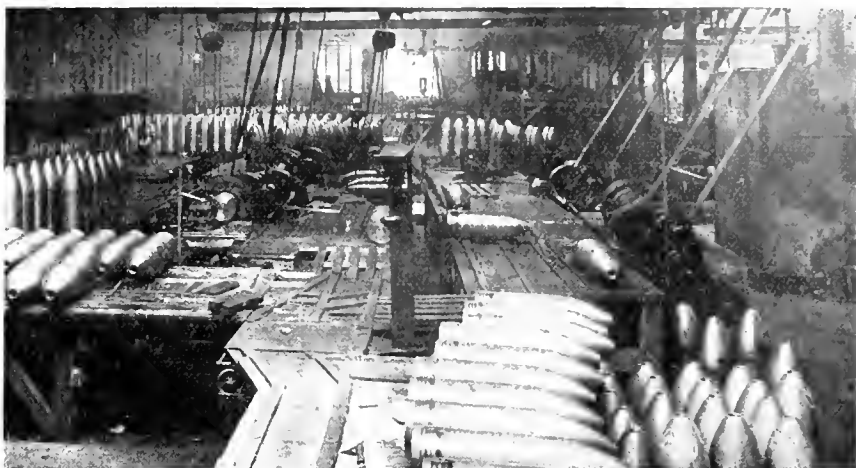

RECTIFYING DEPARTMENT, SHOWING ARRANGEMENT OF BENCHES, LOCATION OF SCALES, BASE FACING LATHES, ETC.

for this class of work. The shell is held in the driving head and makes one revolution while the cutting hob which has an independent drive mills the com-

plete threads. The hob for milling the nose threads is of course smaller, otherwise the method of operation is the same. The shells are handled with chain hoists as in the other operations. In the base there are 8 threads to the inch, left hand, and in the nose 14 threads to the inch, right hand.

Preliminary Inspection

What might be called the first series of operations have now been completed, and the shells undergo a preliminary shop inspection, which is followed by a series of more or less minor operations. The shells while laid on a bench have compressed air blown in to remove chips, and any shell found at the inspection to be rough in the bore is carried over to the buffing machine to be rectified. These buffing machines are of simple design and consist of a wooden stand carrying a cradle on wheels supporting the shell, and also the buffing attachment. The buffer consists of a round bar having two short arms each holding at the end a piece of old emery wheel. The bar is placed inside the shell and the machine

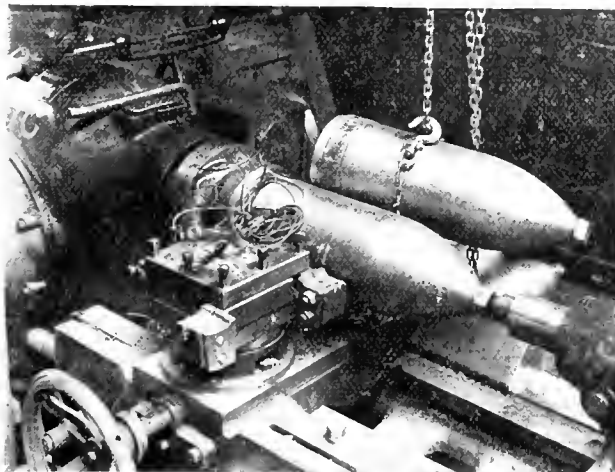

TURNING COPPER BANDS ON CONRADSON LATHE.

started. The centrifugal action of the revolving bar throws the arms out against the inside of the shell and grinds away the rough spots. Any shells rough on the outside are filed smooth while revolving on a fixture with rollers at the side of the bench.

The shells are washed in tanks containing hot liquid to remove the grease and then wiped dry; being afterwards lifted to a bench and rolled along to the adapter fitting department. The section of the plant where the adapters are made adjoins the fitting department, and a description covering their manufacture will be found near the end of this article.

Fitting and Screwing in Adapter

The shells on arriving at this department are first of all weighed. Any shell that shows a little too heavy or light, as the case may be, is corrected by putting in a heavy or light adapter. The latter are fitted into the base as they must be a good fit at the shoulder. The two drive holes in the adapter are then drilled out to 3/4 in. for the wrench used for screwing it into the base. The adap-

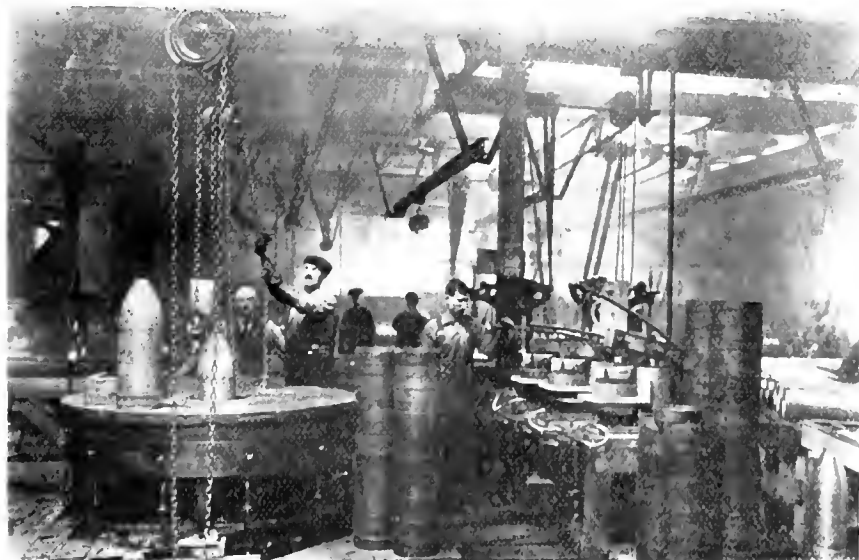

ELECTRIC BAND HEATERS AND COPPER BAND PRESS

ter is screwed into the base and then withdrawn to see if it has seated.

Previous to being screwed finally into the shell, putty is applied to the pilot

heater consists of a transformer core and primary winding, the shell band forming during the time of heating the secondary of the transformer. The yoke

the second is a rough forming tool, the third is the finishing tool, while the fourth tool cleans up the outside edges of band. The forming tools are of steel of special design to conform to the shape of the copper band. The base of shell is held in a special chuck, and a centre is screwed into the nose end. The shells are lifted to the lathe from the runway by a chain hoist and, when the operation is completed, are swung over to the bench behind the operator.

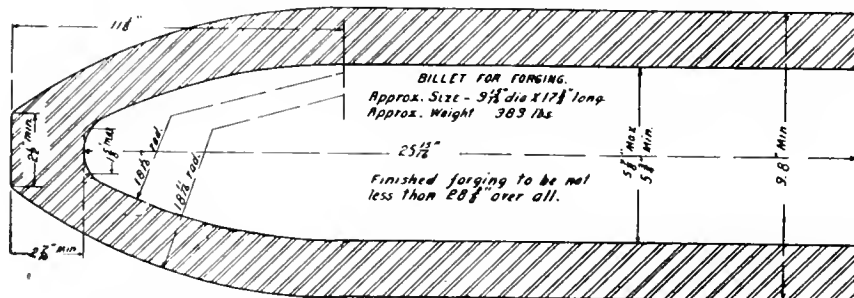

APPROXIMATE FORGING SIZES OF 9.2 INCH HOWITZER SHELL.

or clearance of adapter and the threads are covered with Pettman's cement. As will be observed in the illustration, the shell is held securely in a vise on the floor, while a gang of men with a long wrench screw the adapter home. The base is then examined by a Government inspector and the shell is taken over to the air hammer to have the joint closed up. A circular plate having a number of holes is laid on top of base of shell, which is held in a vise nose down. The holes in the plate guide the hammer and keep it on the line all round while riveting.

Copper Band Operations

The shell is now ready for the copper band which is secured in place by means of a press supplied by the West Tire Setter Co., Rochester, N.Y. The press has twelve cylinders with plungers operating in a horizontal direction, converging towards the centre and distributing the pressure uniformly. The plungers are operated by oil pumped from a vertical belt driven plunger pump. The operating pressure is 2,500 lbs. per sq. inch. One of the illustrations shows the band press and hoist for handling the shells. It also shows the electric band heaters on the right hand. An essential feature of this operation is that the band shall completely fill the groove and undercut. To ensure this it is necessary to heat the band to make it more ductile. There are three Ferranti electric heaters installed, designed specially for this particular class of work. The

of the transformer is made so that it swings out of position on an arm, thus allowing the band to be placed around the primary winding. The primary winding is protected from the heat of the band by a cylinder of refractory material on a shelf projecting from which the band rests. When the heater is switched into circuit a current of 45 amperes at 550 volt. is induced in the shell band. The

Facing Base and Adjusting Weight

The shells are rolled along the bench from the band turning lathes to the next set of machines for the base to be faced up. On the way they are weighed and the platform of the scales being flush with the bench no lifting is necessary. The weight of shell at this stage can be adjusted to bring it within the prescribed limits. The base is rough, caused by the peining or riveting after the adapter was screwed in. The facing operation, therefore, cleans it up and reduces the weight of the shell as necessary. The amount of metal removed varies, but it is usually only a light cut.

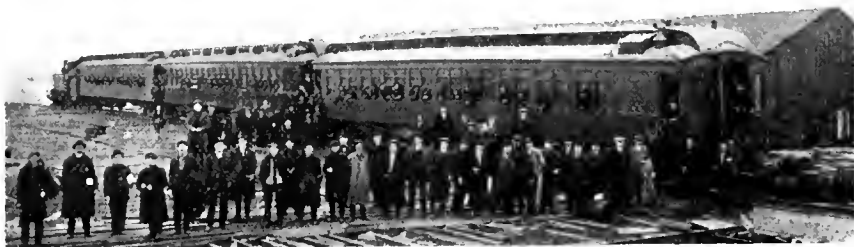

EMPLOYEES' SPECIAL TRAIN, MORNING AND EVENING, TO AND FROM THE PLANT.

time necessary to bring the band to a bright, cherry red heat about 1,500 degs. Fah., is approximately 4 minutes. The copper band weighs 13 lbs. 12 ozs. The inside diameter is 9.085 inches, outside diameter 10.275 inches, and width 2.525 inches.

The copper bands are machined in three "Conradson" 28-in. x 10 ft. engine lathes equipped with a "Phoenix" turret tool post. There are four tools in the tool post. The first roughs the band,

The machines used for the facing operation are "Davenport" lathes, of which there are three, each having a "Phoenix" tool post. The tool post carries two tools, one for facing up the base and the other for rounding the corner of shell. For this operation the shell is held in a specially designed pot chuck, the base end being carried in a steady rest. The view of the rectifying department shows the layout of benches, scales and facing lathes beyond.

Rectifying and Finishing Department

After the base has been faced up, the shells are again weighed and, if correct, are taken along to have the recess in nose finished in a lathe. The shells are next moved along to a bench where the inside is cleaned up. An examination is made for flaws, and cement or any other material that might have been retained inside the shell is removed. The base is then stamped with the various markings, including size of shell, mark IX., initials of firm, date of manufacture, and heat number of adapter forging. The heat number of shell forging is stamped on the nose profile after the finish turning operation being transferred from the base.

The next thing to be done is to hand tap the nose threads and clean up the nose bevel or fuse seat. The shells at this stage have compressed air blown in

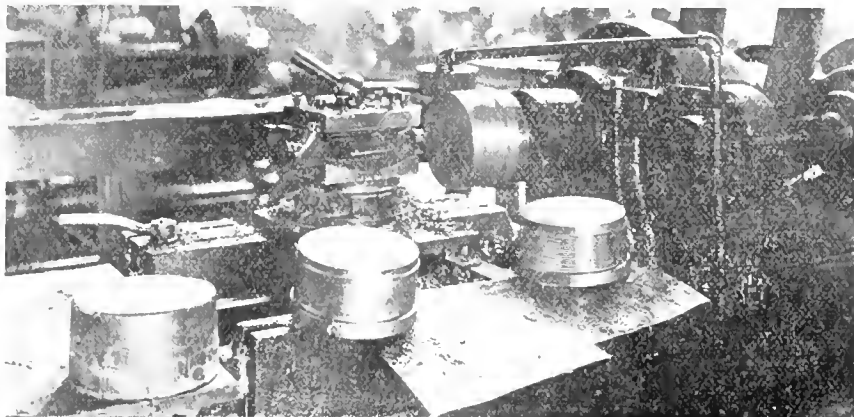

FINISH TURNING ADAPTERS, AND SHOWING THE LATTER IN VARIOUS STAGES OF MANUFACTURE FROM FORGING TO FINISHED PIECE.

to remove chips, etc. They are afterwards rolled along the bench down the shop to be inspected by Government officials who carefully gauge, weigh and examine each shell. After being inspected, the shells are moved along the bench

ing horizontally on the rollers, it is rotating, the varnish being applied with a brush. The varnish is partially dried with compressed air, the shells being afterwards placed on the bench, nose up.

the nose and the outside greased. They are then boxed ready for shipping.

Machining Adapters

The section of plant where the adapters are machined adjoins the adapter fitting department. The adapter is a solid steel forging having the following finished dimensions: Diameter over pilot, 6.48 ins.; over threads, 6.67 ins.; and flange, 7 ins. It is 3.4 ins. thick, the flange being .62 ins., the threads 2.23 ins., with the pilot making up the remainder of the thickness. The first operation done on the adapter is roughing the face and body as far as the shoulder. Four "Davenport" lathes are installed for this work, each being equipped with a special fixture holding two tools. The fixture is in the form of a right angle having a tool at the end of each leg. One tool faces the end while the other tool rough turns the body. The chuck used for this work is much like a universal chuck rebuilt. It has a steel ring around the outside diameter of chuck with set screws for holding the work.

The next operation is rough turning the flange and base. This work is also done on four "Davenport" lathes with a tool post holding one tool. The chuck is similar to the one referred to above, only deeper. The two drive holes are drilled in the base on a "Barnes" drill. For drilling, a jig is placed over the base of adapter to get the holes in the right position. The holes are drilled for a 3/8 in. tap, and one is used for holding the adapter in the lathe at the finish turning and thread milling operations. The holes are tapped on a drilling machine equipped with a reversible tap in which the depth of feed is regulated by a safety appliance.

For the finish turning operation, four 22 in. x 10 ft. "Davenport" lathes are installed, each having a "Phoenix" turret tool post. The adapter is held to the free or drive plate by two set screws which are tightened up behind the drive plate. There are three tools in the tool post. The first finishes the face of the adapter, the second finishes the body, while the third forms the recess under the flange.

There remains only the threads to be milled on the adapter body. The machine used is in many respects like a "Holden Morgan" plug miller, and was "adapted" by that concern for this particular work. The adapter is held in the machine by two long bolts carried through the drive head and screwed in to the drive holes in the base of adapter. The adapter base is tightened up against the drive head of the machine. As in the case of other thread miller, the work makes one revolution while the hob is cutting the threads. The milling hob has, of course, an independent drive. The threads on the adapter are 8 to the inch, left hand. This operation finishes the adapter with the exception of the drive holes which are later drilled out to 3/8 in. The adapters when finished are carried over to a bench in the fitting department to be screwed into the shell base.

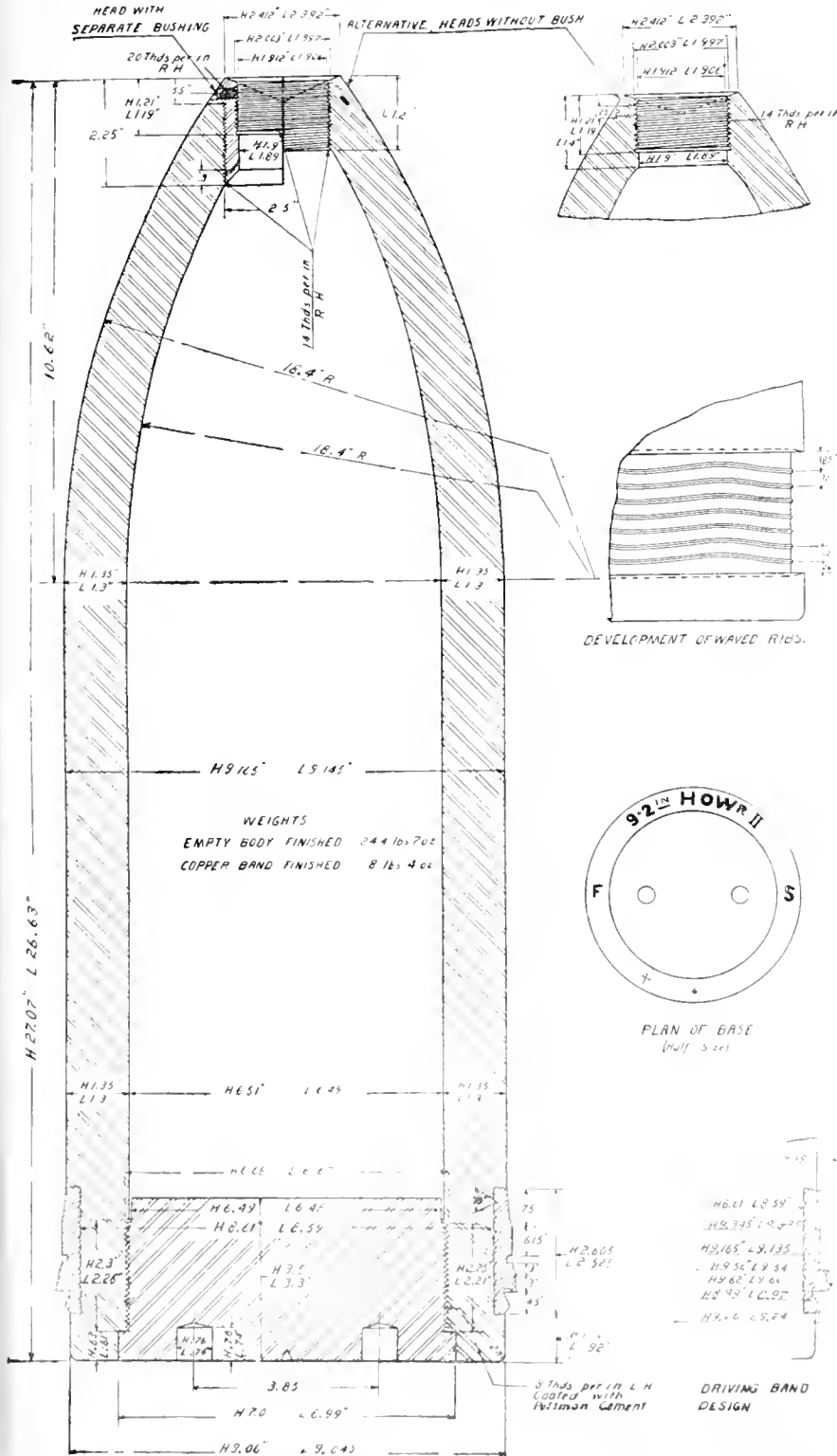

TYPICAL 9.2 INCH HOWITZER SHELL, THE MACHINING OF WHICH IS HERE FEATURED

to the varnishing department. The varnishing machine is a simple affair consisting of four wooden wheels carried on a frame on top of the bench and driven by a belt. While the shell is rest-

and the varnish allowed to finish drying gradually. The varnish used is of air drying quality, and no drying oven is, therefore, necessary. The shells are again inspected, a plug is screwed in

Tool Room

Adjoining the main shop is a well equipped tool room for making and repairing tools, cutters, boring heads, etc., and also for shop repairs. The high cost and one-time scarcity of high speed tool steel, prompted the company to economize in the use of this material. The problem was solved by welding small flat pieces of tool steel to a mild steel shank. This is done in the blacksmith shop near to the tool room.

An important feature, particularly for a munitions plant, is the fire protection system. At various points throughout the plant are glass break boxes, connected to an indicator in the boiler room which shows the location of the alarm. Standpipes with fire hose outfits are located at various points, and a volunteer brigade from both day and night shifts has been formed to meet any emergency. The compressed air installed in the plant is supplied from a steam driven compressor in the boiler room. The line shafts are motor driven, the machinery being arranged in groups.

The location of the plant is such that unusual methods had to be resorted to in order to obtain employees. As there are no houses in the vicinity and only a few within a reasonable distance of the plant, accommodation had to be provided on the job, so to speak. An upper floor of one of the buildings was fitted up as a bunk room, mess room, and kitchen. In the bunk room there is sleeping accommodation for over 150 men. In addition to this, a train chartered by the firm takes employees from a distance back and forward, making two round trips per day, for the day and night shifts.

WORKMEN'S COMPENSATION BOARD REPORT

THE report for 1916 of the Ontario Workmen's Compensation Board, issued recently by Hon. I. B. Lucas, Attorney-General, shows that the compensation for the year, including estimates for continuing disabilities and outstanding accidents, amounts in Schedule 1 industries to \$1,971,675.63, and in Schedule 2 to \$451,709.93, making a total of \$2,423,385.93, or an average of \$7,800 for each working day of the year.

This is a heavy increase over 1915. The compensation in Schedule 1 for 1915 was \$1,091,020.43, as against \$1,971,675.63 for 1916.

Up to December 31 last, 16,192 accidents happening during 1916 had been compensated, 256 being fatal cases, 1,418 permanent disability cases, and 12,896 involving only temporary disability. The corresponding figures for 1915 were 9,289, comprising 251 fatal, 1,034 permanent disability, and 8,544 temporary disability cases.

The total assessments in Schedule 1 for 1916, including estimated adjustments, amount to \$1,948,040.85.

These are contributed by 15,200 employers upon pay rolls aggregating ap-

proximately \$183,000,000, representing the wages of about 240,000 full-year workers.

IMPERIAL MUNITIONS BOARD ORDERS

THE total value of orders received by the Imperial Munitions Board in Canada is \$850,000,000, according to a statement furnished the Minister of Finance by J. W. Flavell, head of the Commission.

The value of munitions shipped to March 30, was \$470,000,000, while the total disbursements to March 30, were \$543,000,000. The number of employees is divided as follows: Headquarters staff 800; inspection, 4,000; workers, direct and indirect, 250,000 to 300,000. Six hundred and thirty factories, chemical and loading plants are in operation in carrying out the orders of the Board. The products covered by these orders include shells and their component parts, which represent an immense tonnage of steel, brass, copper, lead, etc. They include propellants and fuses, also ships, locomotives and cars. An idea of the financial magnitude of the business is obtained from the fact that the cash disbursements for March were \$41,000,000, and will be for April \$43,000,000.

Towards the financing of the business the Dominion has contributed \$200,000,000 as a loan to the Imperial Treasury, and arranged with the Canadian banks for advances aggregating \$100,000,000.

LOAN TO ASSIST SHIPBUILDING

THE Imperial Munitions Board has accepted the offer of Sir Thomas White to make a special loan of ten million dollars to assist in the development of wooden ship building in Canada. Orders have now been placed for steel ships in Canada up to full limit of the steel plants available during the next fifteen months. In view of this, and the need for constructing every possible ship, the question of developing wooden ship building has been under investigation during the last month, and it has been represented to the Imperial Government that a substantial tonnage of suitable vessels could be obtained.

Specifications and designs of the type of wooden vessels required have been under discussion between the Imperial Munitions Board, the representative of the British Minister of Shipping and the various shipbuilding firms. These are now almost complete and will be available as a standard pattern of design. It is hoped to begin work on vessels of this type soon, and the building of a considerable number will be arranged for in Canada, probably for the most part on the Pacific coast, where suitable lumber is available, in abundance.

Priming is the carrying of water from the boiler, in the form of spray, with the steam into the main steam pipes. It is caused by restricted steam space, poor circulation and the forcing of the boiler beyond its normal capacity.

GRINDING OF TAPERS.

By J. Spence.

A TAPER, either internal or external, is a most difficult thing to measure with a micrometer. In ordinary shop practice, master gauges are used that have been carefully machined to the correct taper, and either chalk, Prussian blue or red lead is lightly rubbed on the gauge, if it be a plug gauge, or on the work if it be a sleeve gauge, and the correctness of the bearing judged by the evenness in which the material is rubbed from the gauge, or work. If a sleeve gauge is used on the work, and a slight turning motion be given the piece, and the material is rubbed from the work the whole length of the taper, then we are sure we have obtained the proper setting of the machine. If the marks indicate a heavy bearing on one end only, and none on the other, then we know that our taper is wrong and proceed to correct it from the given clue. Chalk is seldom used to ascertain the truth of a taper in present grinding practice. It is still used, however, to some extent, in lathe work.

The Norton Grinding Co. use red lead entirely throughout their plant in fitting tapers to a gauge, whether the gauge be a plug gauge, as used for internal grinding, or as a female gauge as used in cylindrical grinding. A great number of factories throughout the country use Prussian blue altogether. The advocates of Prussian blue are just as positive of the merits of the blue as we are of the lead. To any one brought up to the use of red lead, the change over to the use of the blue is rather embarrassing for a time. The writer has used both to a considerable extent and is strongly in favor of the use of red lead. It hardly seems possible that any one who has properly applied correctly prepared red lead a single time would go back to any other medium in the fitting of tapers.

To a quantity of dry red lead, just enough oil should be added to make the particles of lead adhere together when firmly pressed. It is a mistake to put in more oil than just enough to dampen the lead. The oil should not be visible, and when mixed properly the lead should have the consistency of partly dry putty. An excess of oil, even to a slight degree, may give a deceptive bearing. The container should be covered when not in use to keep out all particles of dust and grit. The red lead should be spread upon the work in cylindrical grinding, or upon the plug gauge in internal grinding, very lightly so as to show nothing but a very thin film, or bloom. In this way only can a delicate bearing be obtained.

Prussian blue has a tendency to smear. It is difficult to spread the film evenly and quickly without showing an unevenness in film covering. It is this uncertainty in thickness of film that makes it objectionable to one accustomed to red lead. It is sticky and adheres to the surface so firmly that it is somewhat difficult to wipe off quickly before attempting another trial bearing. In the grinding of a long, small diameter-tapered hole this is intensely apparent to the grinding machine operator if he attempts to wipe out the hole before taking a second verifying gauge-reading.—*Grits and Grinds.*

PRODUCTION METHODS AND DEVICES

A Department for the Interchange and Distribution of Shop and Office Data and Ideas Evolved from Actual Practical Application and Experience

HAND-SIZING COUNTERBORE FOR 8-INCH ADAPTERS

By R. Hamilton.

FITTING adapters in the various types and sizes of shell is a very important detail in the manufacture of munitions. It is highly essential that this portion of the assembled shell should be made to fit as accurately as possible in order to prevent the passage of gas, from the propelling charge to the charge in the shell, at the time the projectile is discharged from the gun. While the necessity for careful fitting is obvious in all cases, it is more pronounced in the larger sizes, where the various diameters of the adapter and shell bore increase the tendency to develop defects in the machining that may subsequently interfere with the assembling operation. Many methods have been adopted to eliminate the eccentricity of the several diameters, but complete success has not yet been established. Where the base operations on the shell or adapter are accomplished at one setting, the variation in alignment becomes less pronounced, but when the counterbore and recess and the cutting of the threads are performed at two separate settings, the danger of eccentricity is greatly increased. Where, in addition to this, the turning of the adapter and the threading of the same are similarly accomplished, it is practically impossible to obtain a clean fitting adapter.

The tool here illustrated was designed to assist in the assembling of the 8-inch shells, where it was found that the

means of the grub screw C. This piece B is four inches long, providing ample length for stability. It is a free sliding fit in the tool steel spindle D; this

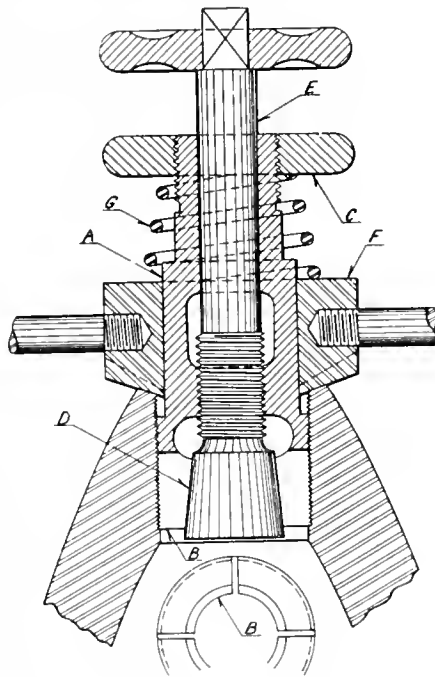

RESEATING REAMER FOR FUSE SEATS.

spindle in turn revolves in the brass bush E fitted to the bore of the large cast iron bush F. The entire device is secured as a unit by the flanged collar G secured to the lower end of the spindle. To operate, the bush is screwed into the base of the shell so that the upper surface comes just below the bottom of the counterbore. Two styles of bushes were found necessary, as shown by the sketch. When firmly in position, the spindle is revolved by means of a double-end wrench placed on the square at the top. The slot in the spindle allows the cutting tool to be moved downwards by operation of the feed screw I. After the cut has been completed, the tool is returned to its initial position by the backing of the feed screw, the reaction of the spring II forcing the tool block upwards.

RE-SEATING REAMER FOR FUSE SEATS

By J. H.

An important essential in connection with the finishing operations on all sizes of shell is that of re-facing the nose to insure a perfect fit between the fuse and its seat. Owing to the possibility of this portion being subjected to damage during its transit from one place to another, either from carelessness or otherwise, it is deemed necessary to give it a final facing previous to its being crated for shipping. This may be done at any time

after the last machining operation, but it is better accomplished just previous to being packed. The sketch shows a device developed by the Imperial Munitions Board for performing this operation. The housing or outer spindle A is threaded on the lower end to fit the fuse thread in the nose of the shell, and is afterwards split, as shown at B. When screwed to position, which is accomplished by means of the handle C, the split portion of the outer spindle is expanded by the action of the cone D on the lower end of the central spindle E; the operating threads being left-hand. The face milling cutter F, operated by the handles shown, is fed by the light spiral spring G, this spring being of the spiral type to permit of raising the cutter to inspect the condition of the face.

AN INTERESTING SHELL GAUGE

By M. O.

DIFFICULTY is often experienced in determining whether the inside profile is of the required dimensions and in the proper position relative to the other portions of the shell. Owing to its location, accurate gauging of the inside contour is a factor generally solved by the shape and adjustment of the cutting tools, so that suitable stops will determine the machining of this section of the shell. To assist, however, in attaining more uniform results in connection with this operation, the Jenckes Machine Co., Sherbrooke, Que., designed the gauge shown in the accompanying sketch; simplicity and efficiency being two of its principal features. The body A is made

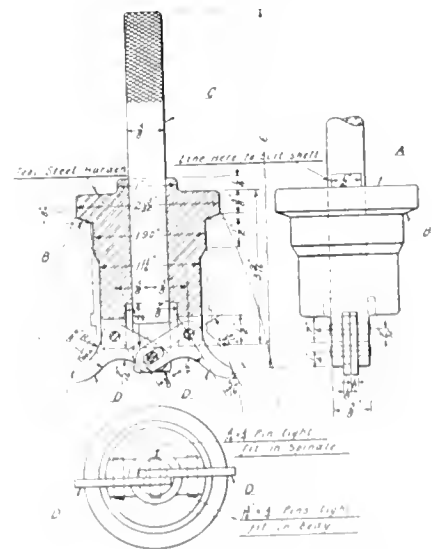

AN INTERESTING SHELL GAUGE.

to fit the finished nose of the shell, the sizing diameter being a free fit for the threaded portion and the bevel part B turned to an angle of 18 degrees, to fit

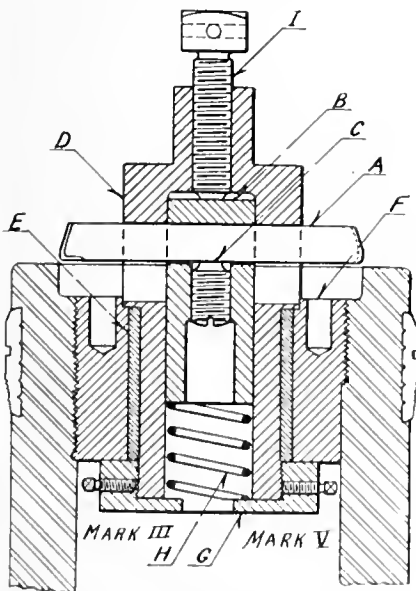

HAND-SIZING COUNTERBORE FOR 8-INCH ADAPTERS.

thread portion and the counterbore were not concentric with each other. The cutter A, which is six inches across the cutting face, is secured in the piece B by

the fuse seat. The spindle C is a sliding fit in the piece A, and is slotted at the lower end to receive the operating end of the two bell cranks D, which in turn are fulcrumed in a slot cut in the end of the piece A. The device is shown in gauging position, graduations being placed on the spindle above the piece A, to indicate same. By lifting the spindle C, the two bell cranks are swung inwards, this being permitted by the location of the slots in the operating end; the gauging points will then clear the thread diameter and the device is easily taken out. This gauge can be used while the shell is still held in the chuck.



WHY A PATTERN IS DIVIDED

By D. A. Hampson.

IT is very hard to get designers and patternmakers to divide their patterns, probably because few of them take the trouble to obtain the moulders' viewpoint. A mould is made in a box called a "flask," that is split horizontally, and in which the pattern has been placed and the sand packed around it. Now note, to get that pattern out, the halves of the mould have to be lifted off the pattern, or the pattern has to be lifted out of the mould; there is a vast difference,

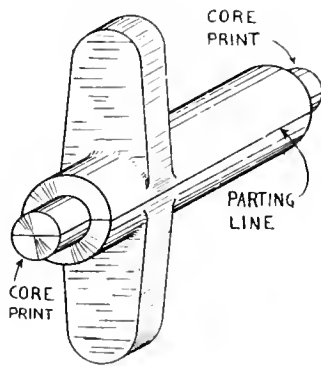

FIG. 1

and on this difference hinges the reason for divided patterns.

As an example, consider the pattern in Fig. 1, which has a deep lug extending on opposite sides of the hub, and core prints at the ends. Assuming that this pattern were made solid, and that we could look into the mould before the pattern was "drawn" (out), we would see something like Fig. 2. The parting line is marked; it is the line between the upper and lower halves of the mould, known respectively as the "cope" and the "drag." In order to get the pattern out of the mould, the cope has to be lifted off the pattern, the latter remaining in the drag if the moulder has good luck. The pattern has in all six vertical faces, and the trick is to lift the cope off so that none of them knock off any sand—a practical impossibility. The rounded hubs and the tapering sides of the lug draw without any trouble, but the vertical faces, even though made with the usual "draft," are sure to catch portions of sand and spoil the mould so that patching up is required. When it is

considered that this cope may be a box 18 or 20 inches square, and 8 or 10 inches deep, and weighing up to a hundred pounds, the proposition of a man lifting it 5 or 6 inches in a perfectly straight line, never raising one corner

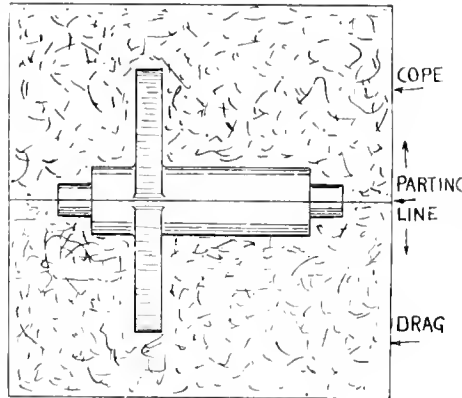

FIG. 2.

ahead of another, is a formidable one. And while he is doing this, he cannot possibly see underneath to gain an idea as to "how she is coming."

Advantage of Splitting

If the pattern be made divided, the patternmaker predetermines the parting line of the mould when he splits his pattern. The pattern in Fig. 1 is split along the horizontal centre line, as noted. To keep the halves in relation, two dowels are put in, one flat face, and enter holes in the other. To facilitate the moulder's work the dowels are made with a good deal of taper, and only fit the holes exactly when the two halves are in actual contact.

Now the divided pattern is put in the flask and has the sand packed around it, just as does the solid pattern shown in Fig. 2, but here the similarity ends, for to get the pattern out of the sand the cope is lifted off and carries with it one-half of the pattern, as shown by Fig. 3. The dowels offer no resistance, and there is no sand to disturb. Then this part of

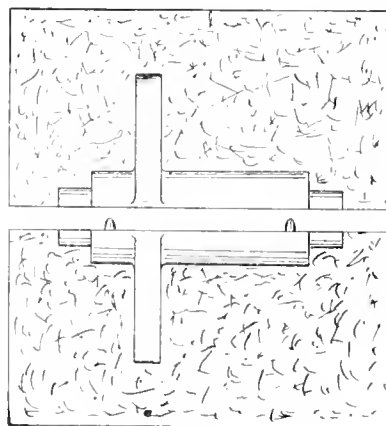

FIG. 3.

the mould is inverted and becomes for the time being just as the other half. It is a comparatively simple matter to draw the pattern out of the sand when

only the pattern has to be lifted; it of itself is light, and the whole operation can be seen. Hence, easier work and quicker, and no patching up to be done. The half pattern can be jarred in the sand ("rapped" it is called), making the space in the sand the least bit larger than itself and removal is a simple operation. In Fig. 4 the half pattern is partly withdrawn.

If the work is rightly planned, divided patterns are as quickly made as solid ones. Because the work is arranged so he can see it, the moulder needs less draft than with solid patterns, and this is a point appreciated by the men in the machine shop who have to work up the castings. When there is a doubt as to where or how to divide a pattern, the moulder should be consulted.



COATINGS FOR WOOD PATTERNS

By D. A. Hampson.

SOME plants have specified colors for different parts of their patterns. The ground work is natural wood finish, core prints are black, and surfaces that are to be machined are red. While this is only a typical color scheme, it serves for an example, and the moulder knows at a glance just what the casting will be and how it will be worked up in the shop.

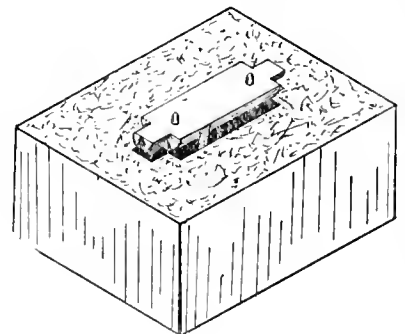

FIG. 4.

But whatever the color scheme, shellac is the basis of the coating, and the various colors are obtained by mixing powders in the clear shellac. Many plants paint their patterns black, and to get that, mix lampblack in the shellac and thin with denatured alcohol.

The present high cost of shellac has brought into prominence one or two very good shellac substitutes, which fill the purpose well, but take a longer time to harden than shellac. It should be borne in mind that the purpose of the coating is primarily to protect the wood from the destructive effects of the damp moulding sand. Holes and imperfections in the wood surface are commonly filled with beeswax; small fillets and corners are formed from it. Paraffine wax is much cheaper and just as good, but patternmakers have trouble in making it stick to the wood. If the pattern is given one coating of shellac first and then the paraffine applied hot, it will stick as well as beeswax.

ADAPTING GASOLINE ENGINES TO BURN KEROSENE

By H. P. Hoag

AS THE price of gasoline advances the interest in the cheaper fuels for the gas engine increases and some experiences the writer had in adapting a line of standard gasoline engines to burn kerosene and naphtha may be timely. The experiments covered a period of nearly two years before the following points were finally settled on. 1st: It was found that heating the air entering the carburetor reduced the power of the engine to a very marked degree. 2nd: To give best results, kerosene and naphtha should be heated nearly to the evaporating point before passing the spray nozzle. 3rd: Water must be admitted into the carburetor with the fuel to retard the burning and give smooth running.

Heating the air was advocated by a number of writers but it was found after trying out many hot air devices, some home made and others from abroad, that in every case the power of the engine dropped, in some instances to but 70 per cent. that of gasoline, so that the hot air idea had to be abandoned altogether, as the manufacturer could not send engines out that would not develop their rated power no matter how well the oil was burned.

Fuel Heated

Heating the oil was accomplished by providing a separate chamber around the outside of the fuel reservoir in the carburetor through which water is circulated, this water being taken from the hottest part of the cylinder jacket. By this means the fuel is kept at the proper temperature and is warm enough by the time the engine is ready to turn on the kerosene; gasoline is used to start with.

Spraying water into the mixture gave a good deal of trouble, that is to get the proper amount for each charge, because when using a throttle governor it became evident that a fixed amount of water for each charge was not the thing, but that the quantity of water should vary according to the load or the amount of fuel taken in. Some means to automatically prevent water running into the cylinder when the engine was shut down was also required, as the operator could not be depended on to turn water off each time.

Use of Automatic Valve

To embody the above requirement the automatic water valve shown herewith was designed, the construction being as follows. In the upper chamber of the valve body there is an air piston C which extends down onto the small inverted valve D. The valve being held up to place by a light spring (not shown) placed inside the valve and the hollow adjusting screw. The opening A is piped into the carburetor between the spray nozzle and the throttle valve. Opening B is piped to a convenient place in the water jacket with a stop cock in the line for shutting off the water when using

gasoline. The action is as follows, (the upper chamber being in communication with the carburetor): when suction takes place the piston C is drawn down against valve D, forcing it away from

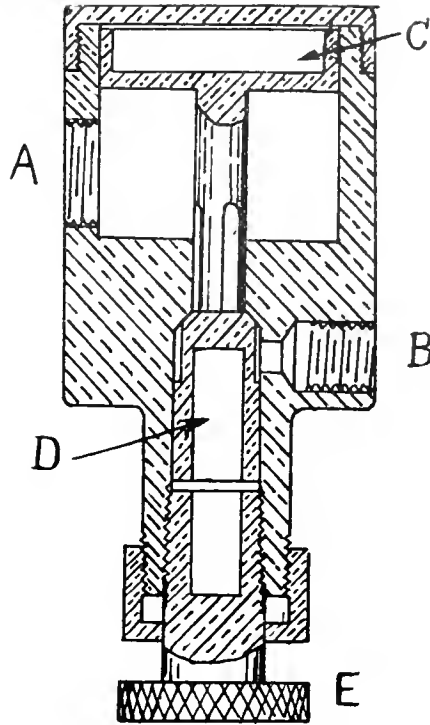

AUTOMATIC WATER VALVE.

its seat by a varying amount according to the load on the engine, when the necessary amount of water flows past the valve D then the pipe from A into the carburetor entering the cylinder with the fuel. It will be noticed there is a fine threaded adjusting screw provided at the bottom to set the stroke of valve D to suit the size of the engine. It is obvious that with this device the quantity of water is varied according to the load also that no water can get past valve D into the cylinder when the engine is not running. With this arrangement it was found not only did kerosene burn (in the ordinary gas engine) as well as gasoline but usually eight per cent. more power was developed with the cheaper fuel.

SAVING TIME ON SCREW MACHINE WORK

By D. A. Hampson.

IN the manufacture of small arms, great quantities of screw machine parts are

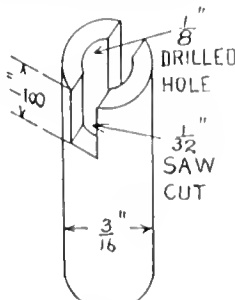

FIG. 1.

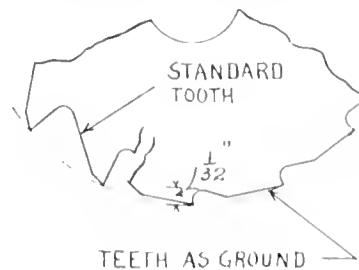

FIG. 2.

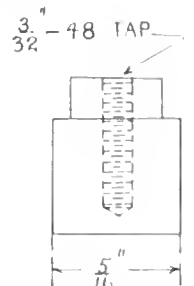

FIG. 3.

SAVING TIME ON SCREW MACHINE WORK

turned out automatically. One piece to be considered is shown at Fig. 1. It is of 3-16 in. mild steel, and has a 1/8 in. hole drilled clear through it, and, while still in the automatic screw machine, the slotting attachment put the 1-32 in. cut through one end. This latter was very hard on cutters, the walls being so thin that the teeth of the cutters were broken in a very short time. The cutters had the standard shape of tooth, as in Fig. 2. and, though regular screw slotting cutters were tried, they fared no better.

Production on the automatics was reduced 5 per cent. by the delay in changing cutters, and the latter had to be bought by the hundred. In trying to better the output, this operation was taken off the screw machine and put on a milling machine, and while it speeded up the work of the former to the right point, the slotting job was as expensive as before, even though the feed of the milling was made specially low in an attempt to prevent "raking" out the teeth.

The whole trouble was solved, as shown in Fig. 2, right-hand side, by grinding the teeth almost entirely away. There is then very little space to catch on the narrow work edge, and the teeth are so stubby that they cannot be broken. One such cutter was usually good for 11,000 pieces before sharpening.

Another mild steel piece made on the automatic is the cap, Fig. 3, with a small, deep, blind hole tapped in it. The production was 1,600 per day untapped, or 900 tapped, the difference being the time spent in renewing broken taps and in running the tap and backing it out, which, of course, was done at a reduced speed. So the tapping was taken off the automatics and put on a \$16 bench drill provided with an Errington tapper. A laborer was here able to tap as fast as the automatic turned the caps out. Moreover, the breakage of taps was not more than one-twentieth of what it was in the more expensive machine, and this latter was kept running at high speed, with no slow down for each piece.

RE-TAPPING SHRAPNEL SHELL SOCKETS

By J. H. R.

TO eliminate the possibility of an undersized thread, due to the continual wear on the machine taps, all threads are generally hand-tapped after the shells are assembled and the sockets screwed to a permanent position. As the



RETAPPING SHRAPNEL SHELL SOCKETS.
G.T.R. SHOPS, MONTREAL.

nity. The illustration herewith shows a Montreal girl at work in one of the munition plants operating a vertical milling machine facing the base of shrapnel shell. A multiple jig holding six shells is secured to the table of the machine, the cutter working continuously upon the upper surface. The operator is seen securing the clamp upon two shells just placed in the jig. As the shells are light, a small hand clamp is provided for removing the greasy shells from the fixture. The production from this machine is approximately 30 shells in 10 hours.

DIES FOR STEEL PILOT FENDER RAILS

By S. P. Y.

IN the manufacture of steel pilots, old boiler tubes are used for the rails, the section being changed to triangular by means of a die similar to that shown in

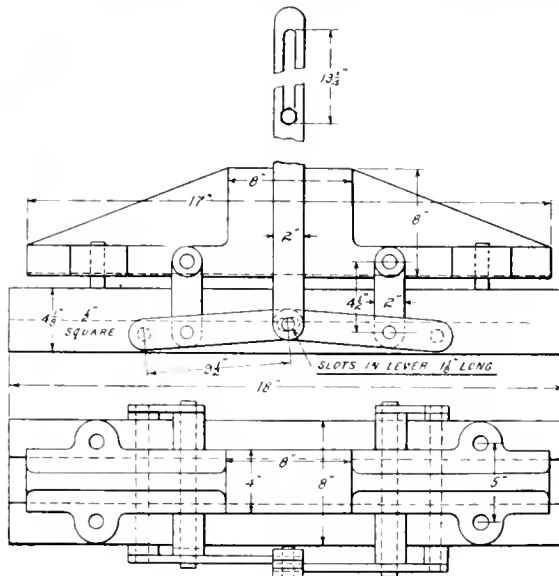

DIES FOR STEEL PILOT FENDER RAILS.

figure in order to provide additional stiffness. The die shown is one that can be placed under any press of the required capacity, the only connection to the

press being the stud on the ram at the correct point to raise the die clear of the job after it has been done, sufficient room being left so that a quick removal can be made.

DEVELOPING OUR LATENT WEALTH

THE Honorary Advisory Council for Scientific and Industrial Research has received reports on many subjects under investigation. Among these are the problems of "the manufacture of nitrogenous fertilizers," "the production of potash from feldspar and other raw materials by various processors," the utilization of the tar sands of the Athabasca region," "the manufacture of oil and other products from oil shales," and "the smelting of iron from iron ores mined in the Dominion" in order to substitute these so far as possible for the ores now imported for different purposes.

actual operation of tapping the hole takes but a small percentage of the total time occupied for each shell operated on, it is an important factor of production to provide means that will reduce the handling of tools to the lowest possible medium. While on a recent visit to a shell plant, the writer noticed the simple device here illustrated, and which has assisted somewhat in the solution of the unproductive factor. Fitted to the stand that supports the shell chuck is a plate that extends up and above the floor stand. Midway up this plate is secured a bracket A, through which the rod B passes freely. The axis of this rod is in line with the centre of the shell, thus aiding in entering the tap into the thread. To the upper end of the rod the chain C is secured, which in turn passes over an overhead pulley and connects with the balance weight D. The device is shown in the operating position, and when not in use is suspended at a short distance above the shell, the tap always remaining in the dumb-bell wrench E.

WOMEN AND MUNITIONS

By B. S.

THE introduction of women into the sphere of munitions work has necessitated the adoption of certain methods that would eliminate much of the labor contingent to the production of the various types of shell. In many respects the weaker sex (physically) have quickly adapted themselves to the changed environment, and are rapidly becoming an asset to the shell-making industry. Much credit is due to those women who have recognized the needs of an unprecedented situation and adjusted themselves to an occupation that in normal times might be considered beneath their dig-



WOMEN AS MUNITIONS OPERATOR IN
G.T.R. SHOPS, MONTREAL.

At present no less than 83 per cent. of all the iron ore smelted in the Dominion is imported.

The Council has also under consideration the question of the uses to which the plants built for the production of munitions of war in Canada may be put, upon the cessation of hostilities. Among the other questions which are under consideration, is a more efficient use of the agricultural lands of the Dominion, and the problem of making the great mass of information concerning the "natural resources of the Dominion" now in the archives of the Government departments more readily available for public use.

Not Her Job.—He was a young subaltern. One evening the Sister had just finished making him comfortable for the night, and before going off duty asked:

"Is there anything I can do for you before I leave?"

Dear little Two Stars replied: "Well, yes! I should like very much to be kissed good-night."

Sister rustled to the door. "Just wait till I call the orderly," she said. "He does all the rough work here."

Tool Holder and Cutting Tool Application Data--II.

By F. Scriber

The approaching return to broader and more general lines of manufacture render a study of tool-holders very timely. While the welded tip has found considerable application under recent conditions of heavy duty and unskilled operation, the obvious advantages of well designed tool-holders are such as to insure a continuance of their use, more especially where variety of work offers increased efficiency opportunities for well assorted equipment.

MANY tool holders have been developed with the idea of establishing a fixed angle of rake, and, in fact, tool holders may be classified largely with reference to this. For instance, there are the holders which retain the blades at a fixed cutting rake; there are those which maintain the blade at a fixed clearance angle, and there are those holders which provide for neither of the foregoing; in other words, they hold the cutter straight.

Mention was made in the preceding article that the blades were usually presented to the work by the tool holders either at right angles or to the right or left of this position, and, likewise, holders were shown in the illustrations which held the blades in these various positions. In Fig. 9 a holder is shown which presents the blade to the work with a fixed clearance rake, the cutting rake on the blade being obtained by grinding; in addition to this, the holder shown is of the swivel type, and the blade may be presented to the work at various angles by turning the head A to the position desired. In any position, the head is clamped by the nut B. The cutter C shown in this illustration is locked by means of the shoe D and screw E.

Tool holders, which are quite often used for planing, are illustrated in the other views of Fig. 9, namely, bolt clamped swivel holder in which the cutter F is clamped by nut G and bolt, while below

of one side of the bolt. It will be noticed in this connection that the blade has the upper side bevelled, by means of

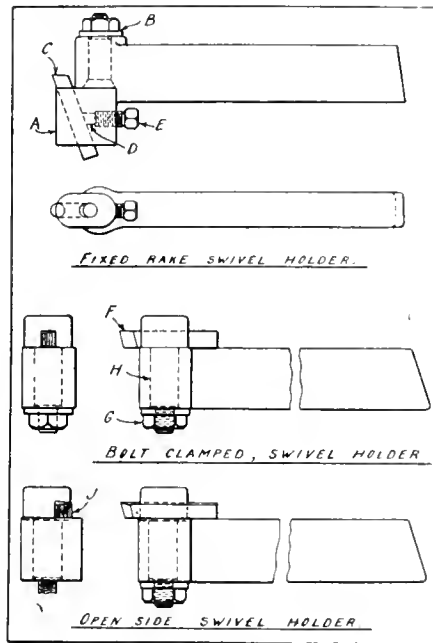

FIG. 9.

which the cutter is held securely against any tendency to side movement which might exist.

Bushing Feature

In the clamping of cutters in tool holders, bushings often play a large part, one advantage of these being that different sizes or shapes of cutters may be slipped into suitable bushings, and the bushing containing the cutter may then be slipped into the holder. Holders in which these features exist are quite varied; upper view, Fig. 10, shows one of these holders, and clearly illustrates the principle involved. Referring to the illustration, A represents the body of the tool, B the cutter, C the nut which binds the cutter in position, the bushing which holds the cutter being shown at D; this bushing as will be noted is split and may be turned to give the cutter proper side clearance. The cutter is held at the proper cutting angle by the bushing, and the clearance angle is ground on the cutter. The bushing with cutter in position is passed through another bushing E and the stud F, when, by tightening the nut C, the whole is readily clamped together against the bar. This tool holder is of the swivel type, and may be set at various angles. A holder which is largely used for planing is shown in the lower view of Fig. 10; this

consists of the clamping bolt G and nut H with holder J. One slot is cut through the bolt G and, through this, the cutter is passed. In the holder J, four slots X are cut, from any of which the cutter may be presented to the work.

A simple and economical holder using milled blades is illustrated at the top of Fig. 11. In this holder the blade is clamped directly by the tool post screw, this being accomplished by placing a plate A on top of the blade while the cutter B is held in the formed holder C. This holder presents the blade at the proper cutting angle and permits of the minimum amount of sharpening; this sharpening is done on the front of the blade at Y. A holder which grips a curved blade is shown in the middle view of Fig. 11, the manner of holding the blade being obvious from the illustration, as the blade is clamped by a screw D at the top of the holder; this screw clamps the shoe E, which in turn clamps the blade. Under this cutter a form plate F is placed. With this method of holding the blade, it is apparent that there is a long gripping surface on the blade, which is often desirable when necking or cutting off work. This form of cutter provides for the necessary cutting rake, and thus the clearance angle only has to be ground on the cutter.

Referring to the lower view, Fig. 11, the blade and holder shown are used for the same purpose as the above. This holder is side opening, and the blade is

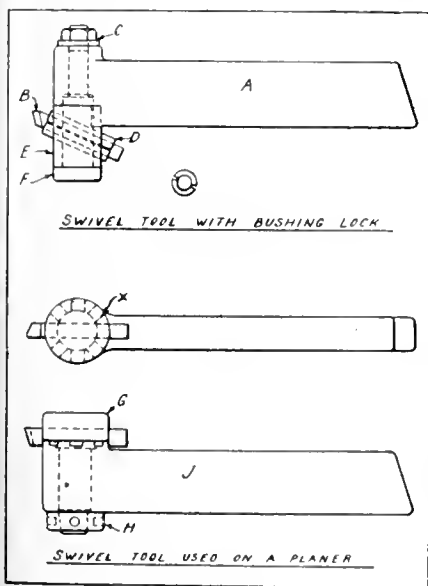

FIG. 10.

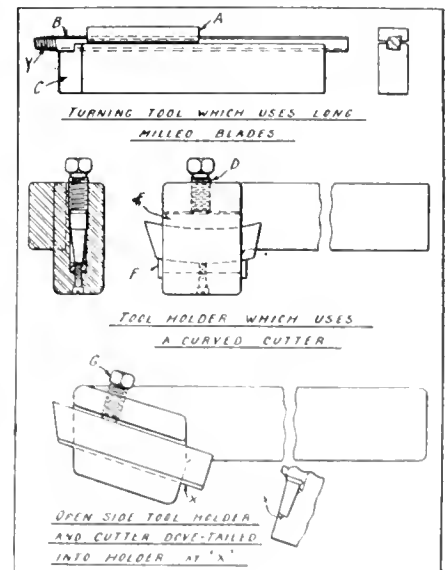

FIG. 11.

held at the proper cutting angle. The blade is also dovetailed into the holder, and is clamped by the screw G. A hold-

is an open side swivel holder, which is operated similar to the one above except that the blade J is held in a slot cut out

er which carries square milled cutters, and is clamped by the tool post screw, and may be made to carry the cutter at the proper cutting angle, is illustrated by Fig. 12. This holder is made in two parts, the two parts being held together by dovetailed slots, as shown at A and B. When the cutter is in position in this

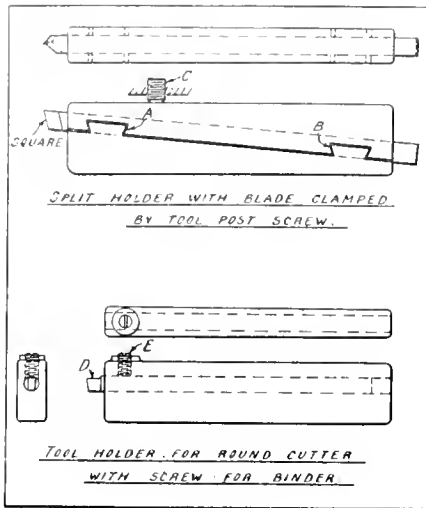

FIG. 12.

holder, the two halves will not come apart, and consequently the cutter is removed from the back of the holder when being reground. By tightening the screw C in the tool post, the cutter is gripped by the upper portion of the holder in the same manner as in clamping any tool holder. In the lower view of Fig. 12, a holder used for light turning operations is illustrated. In this holder the cutter D used is round and is clamped by a headless set screw E.

In Fig. 13 a number of types of cutting-off tools are shown. Cutting-off tools quite often have a tendency to dig into the work, and consequently the tool which holds the blade must be rigid enough to overcome this tendency. This digging-in is quite apt to happen when the work is almost cut off. Cutting-off blades are usually made of a narrow and deep section, the reason for this being that it is desirable to make the width of the cut-off portion as little as possible in order to economize in stock and, in doing this, the blade must, of course, be made deep enough to withstand the strain of cut.

The first illustration in Fig. 13 shows a built-up holder, this being made in two parts. The holder A itself is machined out to receive the blade B, while the plate C is screwed to the side of the holder to keep the blade in the slot. The blade in this holder is clamped in position by a set screw D, the latter being placed in the main portion of the holder, stock having been left in the holder for this purpose. The second illustration, Fig. 13, shows a holder for cutting-off which can be classed as a spring binding cut-off tool holder; the blade in this holder is clamped by the tool post screw, this being accomplished by having the holder slotted at E and F, thus making a

holder which will spring together when the screw is brought down on top of it, thereby clamping the cutter. The flister head screws shown in this holder merely keep the holder in shape, so the blade is a sliding fit in the slot.

Referring to the third illustration in Fig. 13, the blade in this case is clamped by the strap G in the usual manner, a slot having been machined in the holder to receive the blade section shown in the end view. As this strap is tightened, it forces the cutter down into the bevelled set H under the cutter, and the upper bevelled side of the clamp J holds the upper portion of the blade securely against the side of the holder. In the lower illustration, Fig. 13, a holder is shown which clamps the blade at the side, the blade K in this holder fits the slot machined in the side of the holder, and is clamped in place by means of a screw L which is made to tighten the strap M by means of a bar N and the draw bolts P.

Some other types of holders which are of quite interesting construction are illustrated by Fig. 14. The upper views show a cutting-off blade A, which is clamped by a draw bolt B and a wedge-shaped piece C. In using this holder, the blade which fits the slot is put in place; following this the wedge C is placed in position, when, by tightening the nut D, the bolt forces the wedge against the side of the cutter, and also forces it downward, thus securely clamping the cutter in place from the side. The cut in the middle of Fig. 14 shows one view of a cutting-off tool supported by a bar which rests on top of the work being cut off. In this holder, the blade E is clamped by the set screw F at the side, the holder itself G being cut out to receive the blade. At the opposite side of the holder from which the tool is placed, a slot is cut to receive the right angle

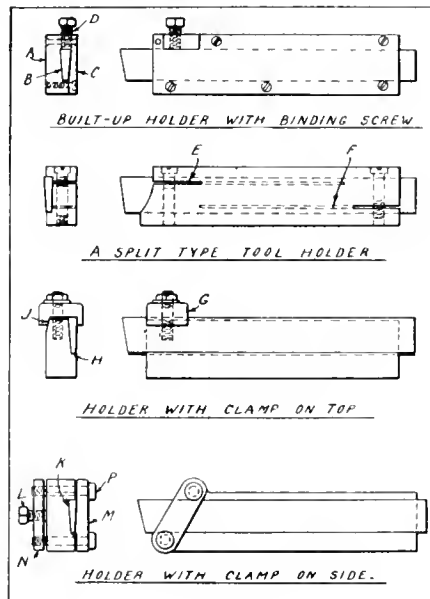

FIG. 13.

part H. Before starting to cut off, the surface X on the bar is brought into contact with the work by sliding this part

up or down in the slot. When the bar is set in the correct position, it is clamped by the two screws J and K. The cutting-off tool is now operated in the usual manner, and the bar supports the part being cut in much the same way as would a back rest in turning.

The lower view in Fig. 14 shows a plan view of a holder, which may be

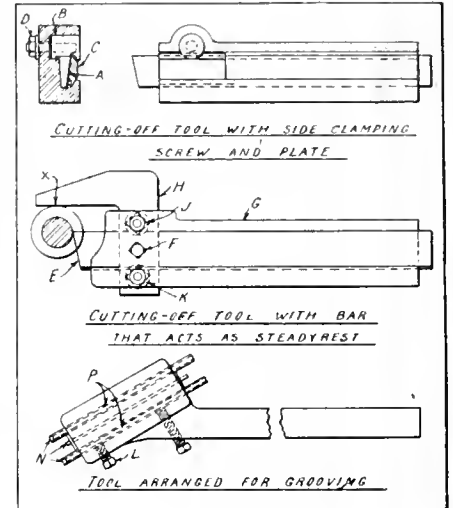
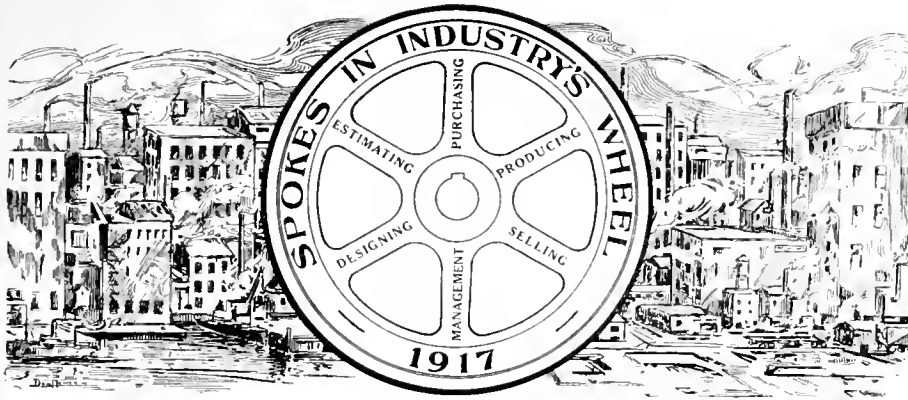

FIG. 14.

used for either cutting-off or grooving. The particular holder shown carries three cutters. These are narrow at the top and of deep section, the same as other cutting-off tools, and are clamped in position by means of the two screws L and M at the sides. The blades N are placed in the holder with spacers between them which hold the cutters the correct distance apart. The cutters and spacers are then, of course, clamped by the screws. When by placing the tool in the tool-post holder and operating in the usual manner, it can be used for cutting grooves or, by placing one cutter slightly in advance of the other, the holder will cut off two or more rings at the same time. The particular holder shown is of a type used for grooving pistons and contains three cutters, two for cutting the ring grooves and one for cutting a small oil groove between the ring grooves. The holder just described is a very economical contrivance, and will be found useful for various purposes, as it can be made to hold one or more cutters up to its capacity, and can, of course, be made considerably wider than shown to accommodate more cutters; the extreme width permissible being dependent upon the rigidity necessary, or the class of work being done.

Other important styles of cutter holders are used for threading purposes; the advantage of these tools being accentuated by the convenience which is experienced when grinding blades of suitable section as compared with ordinary forged tools. A few types of these holders, together with lathe boring and knurling holders will be illustrated in the concluding section of this article in our May 3 issue.



The constitution of industrial enterprise is largely departmental—"spokes in a wheel." This series of articles has for its object the featuring in a raey, interesting and instructive fashion, the training, experience and achievement of those who to-day are transmitting, effectively, energy in their capacity as "spokes in the wheels" of our metal-working establishments.

R. M. McCLEERY

THE county of Kildare, Ireland, forms part of the Province of Leinster, which is located in the East Midlands of the wonderful and historic Emerald Isle. History tells us that this name was derived from the constant and luxuriant vegetation, caused by the more or less continual rains that characterize the land of the Shamrock. Being within the range of the Gulf Stream influence the climate is comparatively mild the year round, the temperature in the month of January seldom falling below 40 degrees. In the town of Athy, not far from the greatest bog in the British Isles (the bog of Allen), the subject of our sketch was born, on July 21, 1883.

Robert Maxwell McCleery, chief draughtsman and designer with the John McDougall Caledonian Iron Works, Montreal, received his boyhood training at the Athy Model School and afterwards at the Athy Private School. At the age of fifteen and a half years, Bob decided to form one of the cogs in the wheels of engineering progress; his selection being the marine branch of the industry. His apprenticeship was divided between the shipbuilding firm of Harland & Wolff, Belfast, and the Central Engine Works; serving 3½ years with the former to marine engineering, and 1½ years with the latter to general engineering and ship repair work.

Realizing the necessity of improving his mental capacity, in the technical essentials pertaining to practical advancement, he found it advisable and also profitable to utilize his spare time in attending the evening classes of the Belfast Technical Institute. In order to broaden the scope of his efforts and at the same time acquire the wider range of experience, that can only be derived by travel, our "spoke", at the age of 22, came to Canada and settled in Montreal. His first position in the land of his adoption, was with the C.P.R., where he acquired a fair knowledge of locomotive construction and repair work. After

about a year with this firm, he served about six months with the the Canadian Linotype Co. of Montreal. In 1906 our "Spoke" became identified with the John McDougall, Caledonian Iron Works; his primary position being that of general draughtsman. Promotion followed his close attention to details, and he has advanced from his initial position to that of Works Inspector, and thence to



ROBERT MAXWELL McCLEERY.

his present position of Estimator and Chief Draughtsman.

Mr. McCleery is a member of Crescent St. Presbyterian Church, Montreal, his other affiliations being membership in the St. Andrews lodge of the A. F. and A. M., and also of the Montreal Chapter of the Royal Arch Masons. As a distraction from mechanical worries, Bob spends many of his recreation hours in his favorite hobby of photography, he being what you might term a professional amateur in this interesting and instructive art. At present our "Spoke"

is not married, but the early future may see a change in this connection.

Few engineering firms in Canada have been permitted to disclaim a part in the development of the munitions industry, and to a great extent, most mechanical men of the country have become more or less familiar with the actual production of one or more types of shell through personal supervision or in the layout of plants or their equipment. Being one of the first to place their plant at the disposal of the Shell Committee, there fell to the executive of the John McDougall Co., the duty of designing special equipment for the manufacture of 4.5 inch high explosive shell, and it is to the ingenuity and resources of our "Spoke" that much of the resultant success was eventually attained. Bob was probably one of the first, if not the first, to advocate and adopt the use of the cast iron chilled die for closing the nose of the shells. When first suggested, this method was ridiculed by many, but our "Spoke" persisted in designing his ideal die, and calculations proved that his surmises were not only satisfactory, but even surpassed his own expectations, the first die used succeeding in nosing nearly 2000 shells before having to be replaced. The cast iron chilled die is now quite extensively used by many shell makers.

Previous to the munitions activity, Mac. was actively and constantly engaged in designing and installing pumping equipment, gas engines and other special engineering work. Since the opening of the war he has personally supervised the construction of patterns and details, together with the manufacture and erection of certain large special wire machines used in the paper making industry. The original of these machines was of German make, but the war prevented the entrance of additional machines, with the result that the John McDougall Co. secured the right to build them, and those already completed are all in successful operation. During the past year our "Spoke" has assisted in the design of two triple expansion engines for a large Montreal shipbuilding firm. The estimating, construction of the patterns, and the casting of the parts were personally directed by him, and it might be here mentioned that the low pressure cylinders of these engines were the largest of their kind ever made in Canada.

"From general observation, regarding the study followed by young mechanics" says Bob "I have noticed that the numerous trade papers (particularly those treating of technical subjects), which come to this office are read with great interest, and in fact I find that in many of them, the different advertisements are intensely interesting and are a great help to me in my own work, enabling my keeping in touch with the various machines, etc., which are continually being placed on the market, more particularly since the shell industry has developed to such immense proportions."

Worm Gear Design Features and Worm Gear Mounting Detail*

By F. W. Lanchester

Progress that may almost be classed as extraordinary in worm gear design and arrangement is largely due to the research expended and inventive genius displayed by interests responsible for the now front rank prominence of automobile engineering.

EFFICIENCY FACTORS

It has been shown that, in worm gears of different types, the efficiency depends upon two factors, the pitch angle of the teeth and a constant—the coefficient of friction. In the work done with the author's dynamometer it has been made abundantly evident that the constant, the coefficient of friction, has a different value in different cases; it is liable to slight variation in almost every different pair of gears tested, but the variation only becomes marked when the type of gear as determined by the system of cutting differs, as for example, in the case of gear of the Lanchester or Hindley type when compared with gear of the ordinary parallel types. Now the reason for these variations has never been thoroughly investigated, and may have appeared to be somewhat obscure; the author has, however, expressed views on the subject from time to time. Briefly stated, the author's suggestion has been that the value of the coefficient is affected by the degree of proximate contact of the teeth and the consequent variation in the thickness of the oil film over the region by which the tooth load is borne—the thicker the oil film the lower will be the coefficient of friction. Although this view has been advanced with a more than plausible show of reason, there has hitherto been no actual demonstration offered in proof, and it can scarcely be said to have obtained universal acceptance.

Tooth Curvature at Engagement Surfaces

It would be possible in the case of the parallel gear to determine as a matter of pure geometry the extent of the clearances and the radii of curvature of the surfaces in contact at different points on the worm and wheel teeth where in engagement, and, in fact, in some degree this has already been done. It is conceivably possible that the same method might be used in the case of the Lanchester gear, but it would be extremely tedious and difficult, and at the best somewhat uncertain. From the photographs so obtained it has been found possible to prepare drawings showing the curvature at the engagement surfaces along the path of motion—that is to say, more or less nearly normal to the plane of the photographic section.

The initial problem of cutting and preparing the worm gear sections has presented certain difficulties of a minor character. In the first place, means had to be taken to ensure that the gears were fixed in their relatively correct running positions, not only before the dissecting of the gear, but as concern-

ing the resulting portions or slices; the worm and wheel had to be so secured that they would be in no risk of losing their relative positions during subsequent handling. For this purpose the gears were mounted in a jig at the correct centres, and in proper engagement, and the whole of the gear teeth in the region of engagement were thoroughly grouted with solder. The next process was to cut away the portion of the gears in engagement, and then to slice these



FIG. 6a.

up in a milling machine into sections of uniform thickness. In order to avoid unnecessary sectioning, both faces of each slice were photographed as representing sections, and the thickness of the slice ($\frac{1}{8}$ in.) was made the same as the thickness of the saw used in the cutting operation. In order that the photographs should read correctly, that is to say, so that they should be readily intelligible, the alternate numbers were reversed photographically, so that instead of the views being from alternately in front and behind the gear wheel, as is actually the case in examining the sections themselves, the photographs represent a series of sections one behind the other, all viewed in one direction.

There was some little difficulty experienced in obtaining a satisfactory process of etching in order to display the difference between the worm and wheel and the solder matrix. An attempt was made to use zinc in place of solder, and then to act on the polished surface with sulphuretted hydrogen or sulphide of ammonia. It was hoped by this means to bring out the zinc as a white ground on which the darker copper and iron sulphide would appear black in contrast. It was, however, found too troublesome.

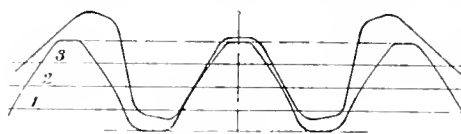

FIG. 6b.

if not impossible, to get the zinc to run properly and uniformly between the two surfaces. Several other methods of etching and polishing were tried.

Ultimately the method used was to etch the surfaces with stannous chloride, SnCl_2 ; under this treatment the worm and wheel appeared white on a dark background. The point of view of the photographs, however, does not give a

clear an impression of the form or of the contiguity of the contact surfaces as might be wished; in order more fully to realize the type of the contact as defined by the difference in the radius of curvature of the two surfaces in their direction of relative motion, a development is required, in the case of the Lanchester the surface being one of double curvature. Any such development is of necessity a matter of convention—a convention involving some degree of distortion.

Determining the Tooth Sections

In the present case the construction adopted has been to take a number of concentric sections, three in all, one on the centre of the tooth height or pitch line, one at one-quarter, and one at three-quarters of the tooth height respectively; the reconstruction has been made in Fig. 7a, representing the Lanchester gear, and Fig. 7b, representing the parallel type. Since it is not the absolute curvature of the surfaces which is important, but rather the difference of curvature, and in order to avoid complicated draughtsmanship, the worm tooth faces have, as a matter of construction, been represented by straight lines, and the whole of the curvature has been assigned to the worm wheel tooth. Thus the tooth sections shown in Figs. 7a and 7b represent correctly the interspace between the teeth in engagement at various points, and so define the degree of proximate contact between the teeth, but the curvature of the worm and wheel tooth faces respectively must not be taken as individually represented.

Referring to Figs. 6a and 6b, which are the middle sections respectively of the Lanchester and the D.B.S. gear, it will be noted that whereas the surfaces represented by their development in Figs. 7a and 7b are surfaces of double curvature in the Lanchester gear, they are ordinary cylindrical surfaces in the case of the parallel worm; clearly, it is necessary to adapt the geometry to the variation of type. Thus, whereas in the Lanchester, as before stated, the development, Fig. 7a, must be regarded as to some extent a convention, in the case of the D.B.S. worm it is a true development of a right cylinder, and the assumption of the uniform and parallel worm teeth is strictly accurate. In Figs. 6a and 6b, the three surfaces of section at $\frac{1}{4}$, $\frac{1}{2}$ and $\frac{3}{4}$ of the tooth height are numbered respectively 1, 2 and 3 in both cases, and corresponding figures of reference are given in Figs. 7a and 7b.

In order that it may be quite clear that the difference—the very striking difference—between the character of the clearances in the Lanchester gear 7a and the D.B.S. 7b are in nowise due to the

*Part II. of a paper read before the Institution of Automobile Engineers, December, 1916.

surfaces of section, Fig. 7c has been prepared on the same basis as that of Fig. 7a. It is not only clear here that no exaggeration of clearances has resulted from the method of representation, but it is also clear that the surface of section must necessarily be chosen in harmony with the geometrical basis of design—thus, in Fig. 7e, the conventional worm teeth appear in places where they actually do not exist.

Now referring to Figs. 7a, b, c, it may be observed that we are not much nearer being able to define how much of the worm tooth actually takes the pressure reaction, but reading these figures in conjunction with the photographs already referred to, we are in a position to state that for a given size of gear (centres), the effective area called upon to support the load will be greater in one case than in another. With so marked a difference in the curvature of the surfaces between the two types, if there were not some corresponding difference in the test result it would certainly be extraordinary. Yet H. Kerr-Thomas, in criticizing my previous paper, said, referring to the efficiencies of the two types of gear, "moreover, if the subject be treated from a purely theoretical standpoint the two [efficiencies] are equal, and the actual experience of a large number of users who employ a

course adopted. Thus, taking the original face preceding the first section as O, the total width being $1\frac{1}{2}$ in., the middle section falls to 6, and what would have been the eleventh section is missing, the terminal face being so numbered.

In the actual cutting of the sections, the thickness of the slices and widths of spaces of the different sections was not found to be accurately the same. This was in part due to the fact that the 1-3-in. saw used was slightly greedy, and cut the gaps wider and the sections thinner than intended, and in part due to the slices having been further thinned by the process of polishing and etching; in the case of the first set to be dealt with (the Lanchester gear), in which two or three experimental polishings and etchings were tried before the results were satisfactory, this is especially true. In transferring the data to paper in the preparation of Figs. 7a, b, c due allowance has been made for these variations.

Rubbing Surfaces Conditions

The conditions under which the rubbing surfaces of worm and wheel perform their duties are not sufficiently defined to allow an a priori estimate of the bearing capacity of the surfaces as based on their radius of curvature, or rather their difference of curvature. The

In the D.B.S. gear, on the other hand, the curvature difference, both in Fig. 7b and in the photograph, is very considerable, but the variations are very considerable from place to place.

Worm Gear Mounting

It has frequently been urged, to some extent truly, that the Hindley or Lanchester worm gear requires greaser precautions in mounting than is the case with a gear of the parallel type. The point is that whereas in the Lanchester type the worm thrust has to be accurately located, in the parallel type, so long as the worm axis is correct as to position, the longitudinal location of the worm is of no importance. The matter may be carried a step further: worm gear of the parallel type in turn may be said require more careful mounting than common screw gear, in which both worm and wheel are of the ordinary screw-cut spiral form. Thus the argument that the Hindley or Lanchester gear is at a disadvantage, on account of the extra precautions required, as compared with parallel worm gear, may be quite as reasonably urged against worm gear of every kind in favour of ordinary screw gearing such as commonly used to drive the side shaft of a gas engine. Such arguments are clearly without

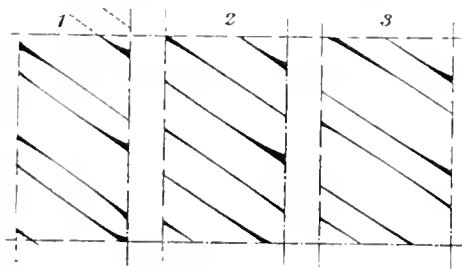

FIG. 7a.

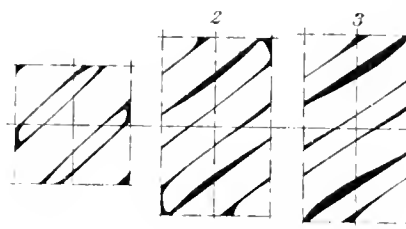

FIG. 7b.

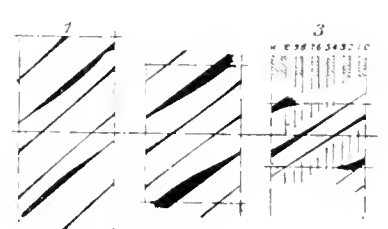

FIG. 7c.

parallel type of worm shows that by this system satisfactory results are daily obtainable." I take no exception to the latter part of this statement—there are degrees of satisfaction—but the suggestion that there is any theoretical sanction for asserting that two so utterly dissimilar types of gear must have equal efficiency is not one to which any reply other than a direct negation is needed.

Of the experimental fact that the Lanchester type of gear will carry more load, centres for centres, than any parallel type hitherto tested, I think there is no doubt whatever. In the results now published there is an adequate explanation of and reason for this experimental fact.

In planning the cutting up of the worm block into sections, consideration was given to the fact that it is desirable to have one of the sections in the plane of the worm axis (as in Figs. 6a and 6b); the plan adopted is shown diagrammatically in the right-hand section (3) of Fig. 7e. The alternative presented itself of either milling away the last section and having no terminal record of the tooth, or of leaving the last section double thickness—the latter was the

curvature, however, must nevertheless remain some criterion, and, as an approximation to the truth, it would be reasonable to assign the bearing or load capacity on the basis that a certain proximity of contact is effective in the transmission of pressure as due to the oil film. The area of the two surfaces capable of transmitting pressure may be taken as an area over which the tooth surfaces come within some definite small distance one from the other. As a working basis we might take one of the surfaces as a plane, and the area in question will then be proportional, for spherical contact, to the radius of curvature, and we know the radius of curvature in the major and of the minor axes, the area of proximate contact may be taken as proportional to the product of the square roots of the two.

The application of this method of assessment is not so easy. For example, in the Lanchester gear in Fig. 7a, and also in the actual photographs, there are surfaces which are optically in contact, and it would take more refined methods than those so far employed to enable the curvature difference to be assessed,

weight if any adequate advantage can be shown to exist.

Location of Worm Thrust

In practice, the whole point of difference hinges on the correct location of the worm thrusts, since in every other respect any want or loss of alignment affects both types of gear equally. It may be doubted, as a matter of experience, whether the Hindley type of worm gear is actually at as great a disadvantage as its detractors would represent. The Lanchester gear, at last, has shown itself capable of working surprisingly well under the severe conditions which supervene when a worm thrust bearing fails. Admitting, however, that the durability of the gear, does definitely depend upon the permanence of alignment, the problem resolves itself into the comparatively simple question of how, under manufacturing conditions, the initial accuracy of alignment can be secured; beyond this, the durability of the alignment resolves itself into a question of fixing the proportion and type of thrust bearing best employed, and of the general soundness of the mounting.

as a piece of practical engineering.

Early Type of Mounting

The earliest type of mounting employed in the application of worm gear to the original Lanchester car is shown in Figs. 8 and 9. Here it will be noted that the ball bearings are not of the modern type, the design dating back to a time when such bearings were not a standardised or a marketed commodity: two double bearings of the bicycle cup and cone type are arranged at opposite ends of the worm, the whole combination being symmetrical. The cups were made adjustable by housing them within an internally screwed sleeve

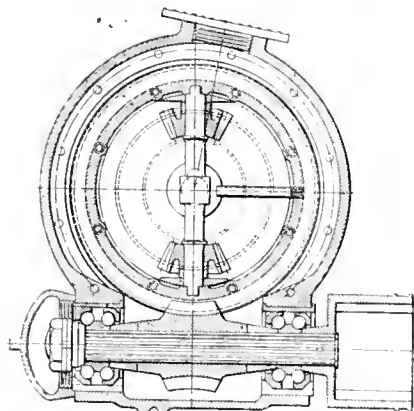

FIG. 8.

piece, and the adjustment was fixed by a key or cotter engaging with one of 24 notches cut in the periphery of each cup, Fig. 8a. The pitch of the thread was twelve per inch, so that the design gave a capacity of adjustment to within approximately $3\frac{1}{2}$ one-thousandths of an inch, which was found to give satisfactory results in practice. Here we stumble against one of the misconceptions which are current with regard to the Hindley type of gear: it has often been represented that the accuracy of alignment of the worm requires to be true to within a thousandth of an inch of geometrical accuracy; from the success of the arrangement described, it is clear that no such degree of accuracy is essential.

It will be noted in the bearing in question that (as in the case of the old bicycle ball bearing) there is no separate function of cylinder bearing and thrust, and without doubt from a modern stand-

ture) as between the two thrust bearings, and it is fair to regard the easing, as indeed the whole of the parts, as

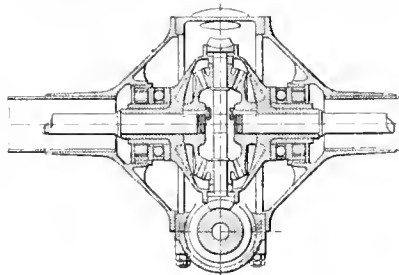

FIG. 9.

sufficiently elastic to take up any small temperature difference. It is possible that at times one thrust bearing is called upon to sustain more thrust and at other times less than its fellow, but there has been no actual evidence of this taking place.

The worm wheel bearings shown in Fig. 9 are roller bearings of the cheese-roller type without cage of any kind. These are in fact the bearings on which the balance gear-box is mounted, and the worm wheel itself forms the central section of the balance gear-box. The thrusts were of a specially designed type, and consisted of balls in a flat cage between two perfectly flat ground and hardened thrust washers, the balls being arranged in a spiral manner Fig. 10. The object of this arrangement, i.e., the spiral distribution of the balls, is that each ball may bear on a different part of the flattened surface, so distributing the wear; a

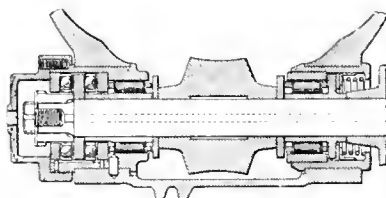

FIG. 11.

further advantage is, that if the balls vary amongst themselves as to diameter, as is commonly the case, each ball will form its own race and will soon be taking its due proportion of the load—the markings on the thrust races frequently gave evidence of this action. The degree of inaccuracy amongst balls of nominally the same diameter is commonly less than one ten-thousandth of an inch. This form of bearing was in every way successful and satisfactory; that it has since been dropped is due to the fact that excellent thrust bearings have now been placed on the market by specialised manufacturers.

Modern Worm Mounting

In the modern worm mounting the type of bearing given in Fig. 8 has been long since abandoned, and to-day it is the invariable practice to separate the functions of radial load and thrust and provide for each by a bearing specially designed for the purpose. Thus, in

Figs. 11, 11a, 12, and 15, a roller bearing is employed independent of the thrust, and in Fig. 16 and those which follow it will be seen that the radial bearing commonly used is the symmetrical type of ball bearing as now to be obtained from several firms, such as the Hogman, Skefko, Duplex, etc., and that thrust is independently carried. In some cases the radial bearing takes the form of a roller bearing, as in the worm wheel bearings already given in Fig. 9.

It is worthy of note that in the modern mountings, the thrust bearing, a double thrust, is almost invariably fitted at one end. Objection has been taken to this arrangement on the ground that any inequality of expansion between the worm shaft and the easing will throw the worm out of centre; in other words, the objection is based on the fact that the arrangement is unsym-

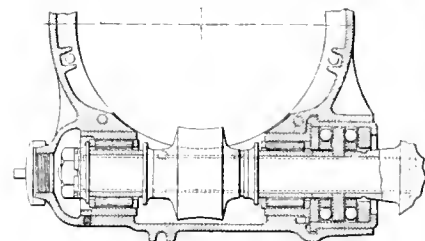

FIG. 11a.

metrical. There are two answers to this. Firstly, the temperature difference is a mere "bagatelle;" thus the whole range of temperatures between the hottest and coolest parts of the gear-box is included between an atmospheric temperature, say 20 deg. C., and an upper extreme of about 100 deg. C.; speaking generally, the difference between one part and another does not exceed 40 deg. C. or 50 deg. C. At worst, calculation gives the relative displacement of worm centre line and the wheel centre line due to the cause stated as not exceeding two or three thousandths of an inch. In practice it is doubtful whether it is ever as great as this: in any case it has not been found to be detrimental. Secondly, if, as is the only alternative, the thrust and counterthrust be arranged at opposite ends of the worm shaft, there will be a much bigger expansion difference to take up between thrust and counterthrust, probably twice as much as now between worm and thrust bearing. This expansion might have a detrimental effect on the thrust bearings and ultimately lead to their disintegration. The failure of a thrust bearing must be regarded as perhaps

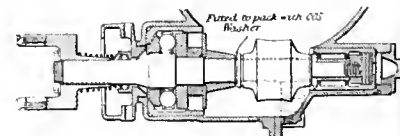

FIG. 12.

the worst "accident" which can happen to a worm gear.

There follow in detail a few of the later and more successful types of worm mounting, and some of those

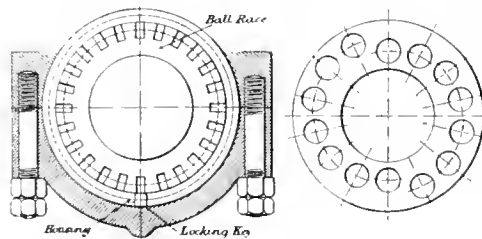

FIG. 8a.

FIG. 10.

point the type of bearing shown in Figs. 8 and 8a would be considered lacking in durability. No trouble was experienced from expansion (due to tempera-

which are historically the more important. The first series which will be taken will be in continuation of Figs. 8, 11, and 11a, showing the historical development of worm mounting in the practice of the Lanchester Company. It will be noted on comparison of the figures given that there are certain features of the Lanchester mounting which have survived from the earliest designs, notably the splined shaft on which the worm assemblage is mounted, also the method of building in the worm wheel as part of the balance gear-box, and in providing for the housing in the worm wheel casting itself of the cross pin or pins on which the balance gear bevels are mounted.

In this arrangement, which is common to the whole of the series, it will be seen that the drive from the bevel wheel is taken directly on to the balance pinions, and the covers of the balance gear-box are not used to convey torque but only the thrust and other forces by which the wheel is held in alignment. It will be noted that the

been applied at the tail end of the worm shaft. This design, again, was before the period in which ball or roller bearings could be purchased from specialised makers, and the bearings were made in

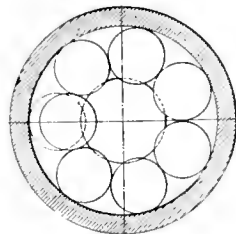

FIG. 11.

every detail at the Lanchester Co. Works. It will be seen that the thrust bearing in this design is very compact, but from the modern point of view and with present-day loads and speeds it would not be considered adequate. Owing to the incline of the worm shaft and the importance of ground clearance, the tail position is at a disadvantage compared with the driving end of the worm shaft in the matter of permissible diameter, hence, when we pass to a later design, Fig. 11a, in which the bearings (both cylinder and thrust) are far more robust, the thrust is fitted at the neck or forward end.

In Fig. 12 (early 20 h.p.) we find that the ball thrust bearing has again been arranged at the forward end of the worm, and in this design an innovation was tried experimentally to do away with the ball counterthrust and employ a series of thrust washers, the efficiency clearly being a matter of no importance when the brake is being employed. A notable feature in this design is the very large diameter of the thrust balls. Fig. 13 gives the corresponding section through the spiral type of thrust bearing with flat races still holding its own.

Cheese Type Roller Bearing

A feature which is worthy of mention in many of these early mountings is the employment of the "cheese" type of roller bearing, that is to say, a type in which the length and diameters of the rollers are about equal. This is a type of bearing which the author developed in the experimental period of ear building, and which was used in the gold medal phaeton built in 1897-S. The employment of this type of bearing was extended considerably in the 10-12 de-

been taken up and introduced by the Hoffmann Co. and others. There is a difference in practice, inasmuch as the bearings marketed at the present day appear to be all fitted with cages, whereas in the author's experience a cage is absolutely unnecessary in bearings of the "cheese" roller type. In any case the guiding of the rollers is done from the ends, and this is really the definite distinction between the ordinary roller bearing and that of the "cheese" type, in the former the roller being guided from its cylindrical surfaces, the cage being a necessity. Generally speaking, it has been the author's practice so to design the bearing that the rollers, once in position, could not fall out; thus in the axle bearings shown in Fig. 9 the diameters of rollers and races were such that the axle or central race could be removed and the rollers could not be displaced. The clearance was so small that the rollers would lock before they could come free, as illustrated diagrammatically in Fig. 14.

A still later type of mounting is given in Fig. 15. On the worm bearings we

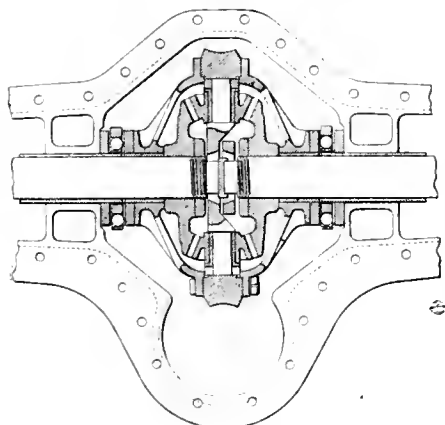

FIG. 13.

thrust bearings serving the balance gear-box take not only the worm thrusts, but also the axle thrusts. There is a bronze pad fitted between the axle ends by which the thrust is conveyed from one axle to the other and thence to the thrust bearing. Another incidental feature which may be noted is the fact that there are four balance pinions in the differential gear-box, each pair mounted on a transverse pin; the figures show clearly the means taken in the design of these cross pins to permit them to clear each other and to clear the axle ends and thrust pad. So far as the worm gear mounting is concerned, these are mere incidents, but the method by which the drive is conveyed from the worm wheel to the balance pinions is a matter which is essentially of interest.

Coming back now to the more directly important points, we may, with reference to Fig. 11, call attention to the first advance in worm mounting after the type shown in Fig. 8. In this we see that roller bearings brought well up to the neck of the worm have been substituted for the bicycle type of bearing in the previous figure, and a double ball thrust between flat parallel races has

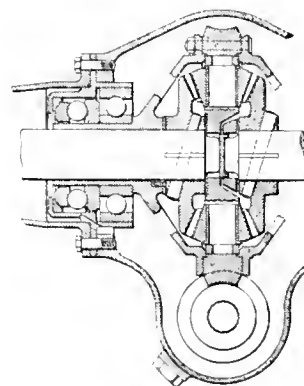

FIG. 16.

again see the cheese roller bearing of the cageless type employed, and a double thrust bearing on the tail end of the shaft. The whole outline of the worm housing, however, has been made very clean and smooth externally. The corresponding axle mounting is given in Fig. 16. Here it may be seen that on the axle bearing the ball has to some extent replaced the roller.

It may almost appear, in looking at these changes, that in some cases, in which the change goes from one arrangement to another, and then back again at a later date, there is certain evidence of infirmity of purpose. As a matter of fact changes are frequently due to conditions which are temporary, and often two designs are so nearly equal in merit that whether one or the other be adopted is purely a matter of convenience. A great deal must depend upon whether the designer has a completely free hand or whether he is required to make use of standard components. It will be noted that amongst the various changes the practice of the Lanchester Co. has always been to place the worm shaft below the axle.

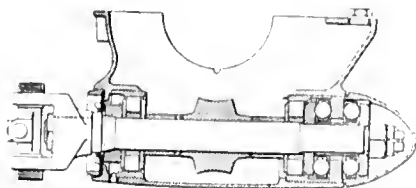

FIG. 15.

sign in 1900, where it was used throughout the rear axle and parts of the countershaft. It is only within the last few years that bearings of this pattern have

PROGRESS IN NEW EQUIPMENT

A Record of New and Improved Machinery and Accessories for the Machine, Pattern, Boiler and Blacksmith Shops, Planing Mill, Foundry and Power Plant

BOSS LOCK NUT SAFETY FACTOR

SAFETY is one of the outstanding features of present day engineering practice. The movement of "protection against accident" has become so general that it is a rare plant indeed that minimizes the importance of this essential factor. The application of the "safety first" principle has met with



SQUARE AND HEXAGON LOCK-NUTS

such universal approval that manufacturers of every description are rapidly recognizing the many advantages that result from its more extended operation.

Accidents to operators and destruction to machinery can be traced to many sources, but it is safe to say that a fair percentage may be caused, directly or indirectly, by the loss of a nut from some part of the plant equipment. Owing to the vast and varied uses to which bolts are put in the construction of every conceivable piece of mechanism, and the important part they play in the successful operation of machinery, it is essential that sufficient means be provided to prevent the displacement of a bolt from its fixed position. This feature of engineering practice is more pronounced where bolts and nuts are used to connect parts of machinery, or other construction, subjected to continual shock or vibration. Under these conditions, it is very necessary that ample consideration be given to the prevention of accidents, often caused

It has been often said that "Prevention is better than cure," and this term is equally applicable to engineering as to "other forms of evil." To prevent a nut being displaced is, therefore, much better than to repair the damage after the accident has occurred. Many forms of jam or lock nuts have been designed and adapted to retain bolts in their initial position. The simplicity of the nut here illustrated is one of the chief features of its efficiency. The construction of this lock nut is designed with the threads tapped out to standard size, so that the nut can be placed on the bolt and spun up to the primary nut by means of the fingers, without the use of a wrench. It makes no difference which side is in contact with the adjacent nut, as either side may be used with the same effectiveness. These nuts, which are cut from a bar, have two parallel sides, the faces being concaved at right angles to the edges, forming a regular arch. When the nut has been spun down to the face of the primary nut, the two parallel edges of the lock nut come in contact with the face of the other, and by means of a wrench the lock nut is turned through an angle of from 90 to 180 degrees. The pressure thus exerted bends the lock nut, causing the threads therein to be distorted, consequently gripping the threads of the bolt very firmly, so that it is impossible for the nut to become loose.

Even should the bolt elongate under the strain and the primary nut become loose, the lock nut will remain in its original position, so that any slackness cannot exceed the elongation of the bolt, which is seldom, if ever, sufficient for the bolt to become loose. When the arch has been drawn downwards so that the threads register deeply and firmly into

lock nut. If it is necessary to remove a bolt upon which these lock nuts have been used, the lock nut can only be removed by means of a wrench, and this acting throughout the entire length of the threaded portion. These nuts are being placed on the Canadian market by the Boss Lock Nut Co. of Canada, 263 St. James Street, Montreal.

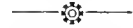

HEAVY DUTY PRECISION DRILLING MACHINE

THE machines shown in accompanying illustrations have been designed with a view to obtaining the highest efficiency

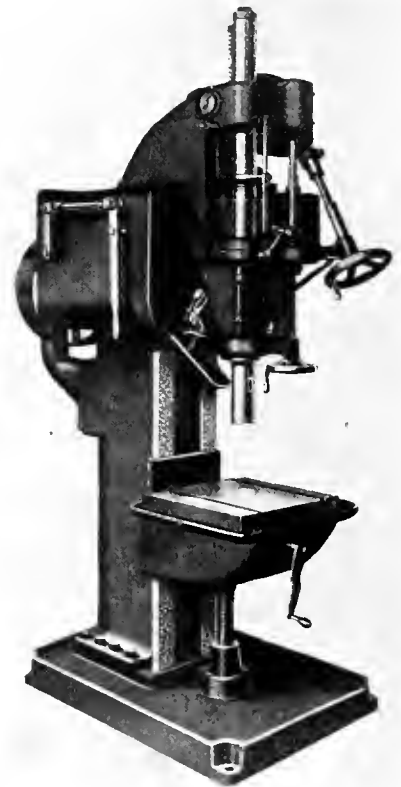

HEAVY DUTY PRECISION DRILLING MACHINE.



BOLT WITH LOCK-NUT IN POSITION.

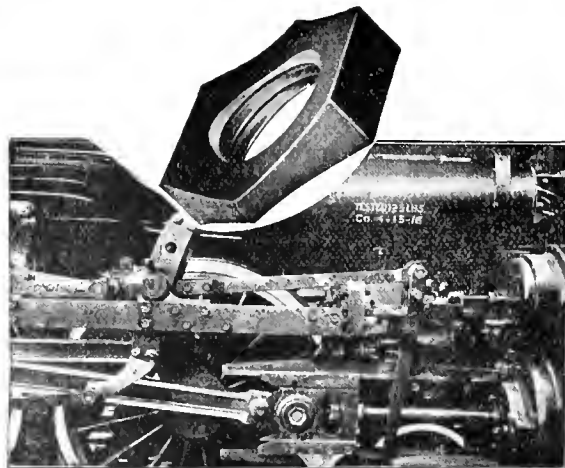

VIEW SHOWING APPLICATION OF LOCK-NUT TO LOCOMOTIVE PARTS.

by a nut being dislodged, with possible disarrangement of the machine parts, followed by accidents to the equipment or the operators.

the valleys of the threads of the bolt, the lock is so positive that no movement will take place between the three members—the bolt, the primary nut and the Boss

in performance, including every requirement from heavy-duty capacity to precision work of the greatest accuracy. Reference to the illustrations will show that the machines are almost similar as regards the column and mechanism, but different designs of base and table are provided for the particular class of work in view. Simplicity in construction and operation have been kept constantly in mind, resulting in very complete freedom from complicated levers and handles.

The machine shown in Fig. 1 has a heavy column of box construction bolted to a base of generous dimensions, the part of the base under the column being ar-

ranged to form a reservoir for the cutting compound which passes through a sieve into the reservoir. The work table is mounted on planed ways on the front of the column, these ways being carried up

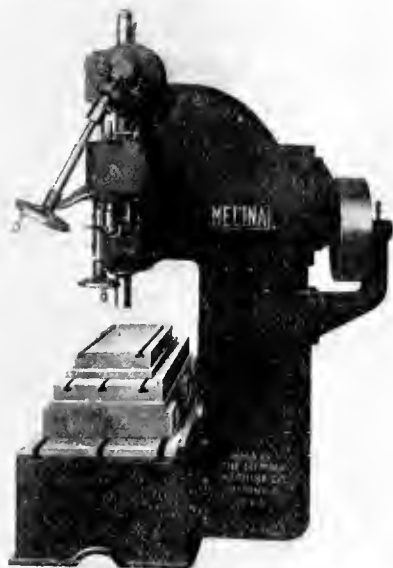

HEAVY DUTY PRECISION DRILLING MACHINE.

high enough to allow of mounting special boring heads for multiple spindle drilling work. The table itself is plain box

Constant speed drive, either belt or motor, is a feature of the design, the variation of spindle speeds being obtained by a speed box contained in the interior of the column. The speed box contains nine hardened change gears and four semi-steel wide-faced gears operated by the controlling clutch. Gear changes are made by a roll-in gear, and only two idle gears are in mesh when the machine is in operation. For single purpose work, the speed box can be replaced by a single speed drive or a three-step cone.

The spindle is provided with a sleeve carrying a large bevel gear which is driven by the bevel pinion of the speed box. The bevel gear is secured to the sleeve by two steel keys, which are so designed that the torque from the bevel gear is transmitted direct to the spindle on its largest diameter without causing stress on the sleeve. The lower end of the sleeve has a tapered bearing in the spindle head; its upper end is straight and is fitted with a tapered sleeve keyed in place, this arrangement allowing the sleeve to expand without tightening the bearings, while maintaining the spindle and sleeve in alignment. Both the spindle and sleeve are of forged crucible steel and accurately ground to fit each other and the sleeve bearings.

The bevel drive gears and worm feed gears are housed in the spindle head and run in grease, and the spindle sleeve double friction clutch starts and stops the

provided with safety friction and automatic knock-off.

When constructed as in Fig. 2, the machine is known as a universal spacing machine, the arrangement having been developed to meet the requirements of jig boring and similar operations, and it is suitable for regular operations, on work where it is necessary to bore holes to close limits without the use of jigs. A specially designed adapter gauge, not shown, combined with use of set blocks enables holes to be spaced within .00001 in. A planed strip extends along the rear of the base and also of the platen resting thereon, both of which have three T-slots for securing in place. The auxiliary platen on top may be used either with the main platen or base as required and is located in position from the planed strip at rear, an adjustable stop secured in the T-slot providing a base point for sidewise location.

Leading dimensions applying to both machines are: spindle dia. 3½ in.; spindle traverse, 14 in.; 8 spindle speeds from 54 to 414 rev. per min.; 4 power feeds, .006 in. to .032 in.; capacity to drill, 3 in.

These machines are the product of the Medina Machine Co., Medina, O.



SHELL BASE FACING MACHINE

THE removal of surplus metal from shell forgings constitutes an operation which calls for considerable power, but

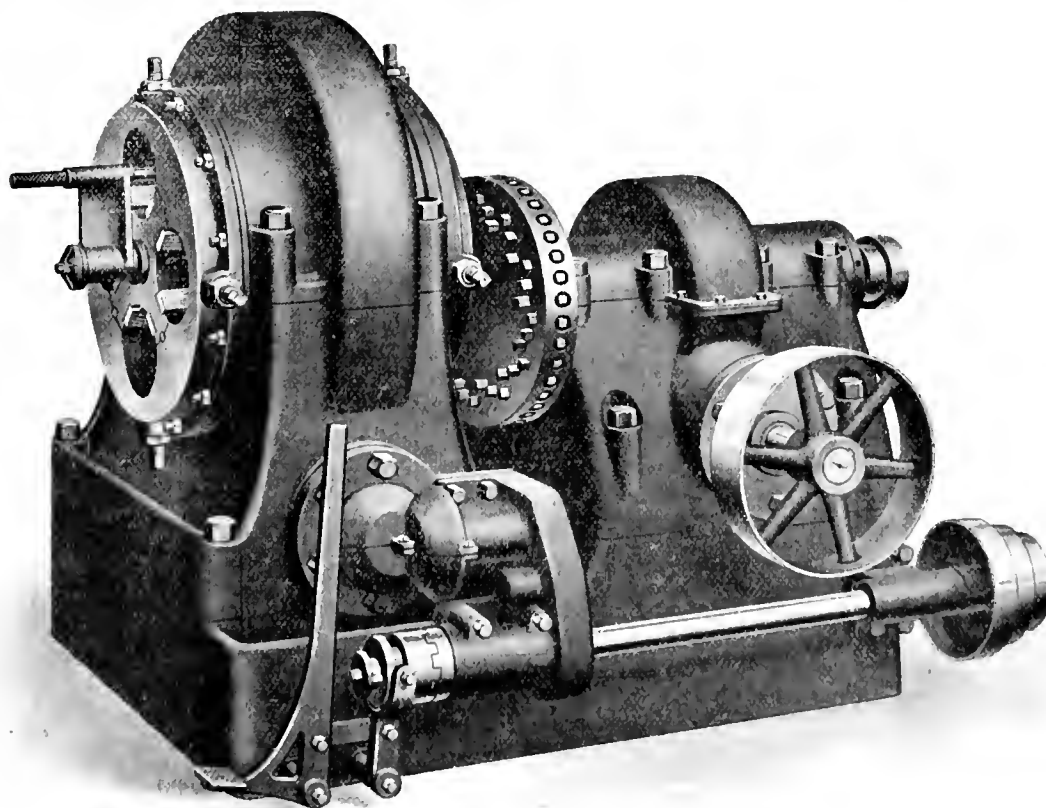

MILLING MACHINE FOR FACING BASES OF 6 IN. SHELL FORGINGS.

section, strongly ribbed, and has channels around edge to carry off compound. It is secured to the column by heavy straps; has liberal bearing and length on column, and is raised and lowered by telescopic jack screws.

machine, and a ball thrust bearing carries the thrust of the large drive bevel.

Semi-steel gears are fitted in the feed box, with slip key that moves into the particular pair of gears selected. The feed box is bronze bushed throughout and is

is of such a nature that the use of turret lathes and similar types of tools is not always accompanied by the highest degree of efficiency or rate of output. These and kindred considerations prompted the development of the con-

tinuous shell base facing machine illustrated herewith, which, while classified as a single purpose tool, is adaptable to much other work where a large amount of stock is to be removed.

The design is featured by the use of a revolving cylinder or magazine having four axial holes or pockets in which the shell forgings are placed. The shell pockets are fitted with hardened tool steel inserts for holding the shells, which are securely clamped at each end by hardened binder screw working in removable steel nuts. The magazine is rotated in its bearings by means of a worm gear which surrounds it, and is driven by a steel worm running in oil.

The steel cutter head is 1 9/16 in. dia., and carries three rows of high-speed tools, and is mounted on a high carbon steel spindle driven by a 16-in. worm gear. Each of the spindle bearings is 5 1/2 in. dia x 10 in. long, ground to size, and running in phosphor bronze bushings. The worm gear is of bronze and meshes with a steel worm, which, like the magazine worm runs in an oil bath.

A three-step cone, with 2-in. belt, operates the magazine feed gear, an alternative being an all gear drive and gear box, which gives four changes of feed. All-feed gears are of steel, with bronze bushed bearings, and a hand or foot operated clutch is provided on the feed shaft for controlling the rotation of the magazine. The base of the machine forms an oil tank, a geared pump and pipe connections being supplied.

This machine is designed to handle 6-in. shells, and is built by the Rollins Engine Co., Nashua, N.H., and occupies a floor space of 5 ft. 9 in. x 4 ft. 7 in.

friction-driven headstock, the combined operation of which is accomplished by a pedal. A spring underneath the sleeve draws the collet back into the spindle and closes it on the work.

This sleeve is spanned by a forked lever, which, when operated by the pedal, opens the collet and stops the spindle instantly, so that the work may be adjusted by the operator whose hands are both free for handling material or tools.

The spindle runs in self-oiling bronze bearings, and has a hardened bushing fitted in the nose to prevent wear by the collet. It is also threaded to receive chuck or face plate.

This machine is a recent product of the J. G. Blount Co., Everett, Mass., and can use collets up to 5/8 in. The headstock is also arranged for mounting on bench.

OUR PRESENT PROSPERITY DUE TO STEEL

ROBERT HOBSON, president of the Steel Company of Canada, stated at the annual meeting which was held in the Royal Connaught Hotel, Hamilton, on April 19, that the steel business would continue to be large while the war lasted, but on peace being declared there would be a period of adjustment. The old board of directors was re-elected and the annual financial statement, which had been issued earlier to the shareholders, was received and adopted, in this statement it was shown that the net profits for the year after deducting charges for repairs, maintenance and improvements and providing for war taxes for the year 1915 and 1916 were \$5,021,391.53.

The period of adjustment after the war, said Mr. Hobson, will mean that financial arrangements in Europe will have to be lined up and the credit of foreign

steel plants in Canada had been fully proven during the past two and a half years. Without these plants, Canada could not have provided the material for the vast quantities of munitions which had been turned out since the war started. Such activities, he said, had been largely instrumental in putting Canada in her present favorable financial position. Reference was made to the fact that the company had provided a fund for nearly one million dollars to meet after war conditions.

FELLOWSHIPS FOR RESEARCH WORK

TWENTY studentships and five fellowships in Canadian Universities will be established by the Honorary Advisory Council for Scientific and Industrial Research. The studentships are open to both men and women, and are each of the value of \$600 for the first year and \$750 for the second year. The candidates for studentships must be British subjects, resident in Canada or graduates of Canadian Universities, and must be between the ages of twenty and thirty-two years. Applications for studentship must be made to the Advisory Council.

The research fellowships are of the value of \$1,000 for the first year and of \$1,200 for the second year. Fellowships will be awarded those who either through previous tenure of a studentship or otherwise have shown a high capacity for research on some problem the extension of which is of importance to the national industries of Canada.

Hospital Humor—At a certain hospital, which shall be nameless, there is a doctor so dark in complexion as to be generally considered a half-caste, but it is impossible to offend him worse than by an allusion to the fact.

This gentleman, though very clever, is somewhat unsympathetic.

Recently a number of wounded soldiers were received into the above-mentioned institution, and amongst them was a Birmingham man who had borne a great amount of suffering very patiently, but became rather irritable as he began to recover.

One day the doctor surprised this particular patient by inquiring if he was breast-fed or bottle-fed as a child.

The man replied that he thought he had been breast-fed.

"H'm I thought so," remarked the doctor, sarcastically. "I have frequently noticed that people who were breast-fed as children make ten times more fuss in illness than those who were brought up on the bottle."

"Which were you brought up on?" inquired the soldier, after a short pause. "Bottle," replied the doctor, shortly.

"Ah! I thought so," replied the Tommy contemptuously regarding the dusky skin of the other, "and it must have been a bally ink-bottle too!"

FRICION HEADSTOCK LATHE
THE lathe shown in the accompanying engraving is especially adapted for the

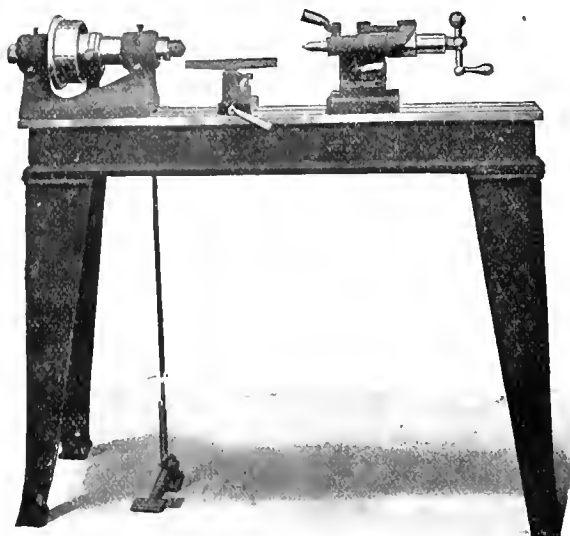

LATHE WITH PEDAL-OPERATED FRICION HEADSTOCK AND DRAW-IN COLLET.

rapid production of small machine parts, and, with this end in view, has been provided with draw-in mechanism and

purchasers, other than the Government, will have to be carefully considered. He said that the wisdom of establishing

The MacLean Publishing Company

LIMITED

(ESTABLISHED 1888)

JOHN BAYNE MACLEAN - - - - - President
 H. T. HUNTER - - - - - Vice-President
 H. V. TYRRELL - - - - - General Manager

PUBLISHERS OF

CANADIAN MACHINERY AND MANUFACTURING NEWS

A weekly newspaper devoted to the machinery and manufacturing interests.

PETER BAIN, M.E., Editor. B. G. NEWTON, Manager.

Associate Editors.

A. G. WEBSTER, J. M. WILSON, J. H. RODGERS.

Office of Publication, 143-153 University Avenue, Toronto, Ont.

Vol. XVII.

APRIL 26, 1917

No 17.

MACHINE SHOPS AND TRACTORS

PRESENT conditions in regard to agriculture and its resultant effects on the world's food supply have caused more than a passing interest to be taken in the matter of power cultivation. Numerous concerns, particularly in the States, are reported to be entering the tractor industry daily, and production estimates of four and five figures are spoken of with the same glibness that was shown when the "caterpillar" principle was brought so prominently before the public by the success of the tanks.

Much public discussion will not result in any mechanical idea being adopted on a wide scale simply because it has achieved marked success under peculiar circumstances, and the fact that caterpillar tractors have been regularly produced for something like twenty years, without any signs of recognition by agricultural experts and publicity mongers, would seem to indicate a lack of appreciation and consequent inability to pronounce on the merits of such machines. Caterpillar tractors obviously have special applications and more or less limited markets and should not be confused with what might be termed the "iron horse" which the average farmer requires.

Out of the numerous designs which have appeared in recent years a type or types will survive, and a sympathetic study of average farm requirements by technical experts should do much to hasten a finality of design. The use of kerosene and low-grade fuels is quite as important as whether there should be three wheels or four wheels, but if a tractor is to displace horses in the field it should also displace them in straight road haulage. There are, of course, some circumstances where a horse may not altogether be dispensed with, but the displacing of the buggy by the automobile really removes the last toe-hold of the horse.

Excepting the motor, which can generally be obtained to advantage from specialized producers, a practicable and efficient tractor design does not offer any constructional problems which cannot be successfully handled by many firms in the Dominion. Intricacy of design and complexity of construction will not avail in the tractor of to-day as they did in the early automobile, and the simplification of tractor design to the point mentioned is well within the ability of any competent machine designer.

The question of marketing would offer new problems to

certain producers, but a firm which adopted aggressive demonstration methods with the same energy and resource as are frequently displayed in marketing machine shop equipment, would not lack work for years to come, provided it had the goods.



COAL WILL CONTINUE SCARCE AND DEAR

WITH the advent of spring weather and the near approach of the good old summer time, there is already evident a disposition to forget our past winter troubles and inconveniences, due to lack of coal for manufacturing and domestic services in both quantity and quality, the latter probably more aggravated than the former. Even now, when to all appearances, we are still well removed from the firing of the last shot in this apparently cruel war, a powerful public opinion—essentially scientific and moral perhaps, deems the conflict to have been worth while and altogether necessary to our future well being. The reason is not far to seek, and need not be looked for en masse; it being as a matter of fact a more or less individually determined conclusion arising from personal experience. We have come to appreciate things more in keeping with their proper value and in so doing to extract from them the commensurate return. It is hard, however, to get away altogether from the idea that the war in much of its detail has been other than tyrannical, and so far as we on this North American continent are concerned, the coal situation during the past winter on many occasions by its maintaining a generally threatening aspect and seriously affecting industrial enterprise and domestic comfort, contributes its quota to such a condition of mind. From well authenticated sources, our information is that not only may little price relief be expected—if any, but much below normal supplies of coal are also likely to be received. The 1917 season of navigation on our lakes and rivers is going to be less effective in accumulating coal supplies than ever before, due not only to the shortage of "bottoms," but to such other causes as the shortage of labor at the mines, and the reduction in railroad rolling stock available for such service. The foregoing applies to coal receipts from within our own borders, as well as those from beyond.

Already not a few enterprising concerns are investigating the possibilities and propriety of installing oil fuel equipments in connection with their present boiler layouts, whether high or low pressure be their service, and there is little doubt that before the summer season is well through, definite progress in this particular direction will have been made in many cases. It seems in order to again impress our readers—executive and operative, with the remote prospect of lower coal prices during the summer season than those now prevailing, and to advise that not only will they be higher during next winter than last, but the higher levels will be reached much earlier than usual. Something like \$5 per ton for bituminous coal at pit mouth, in Pennsylvania is now quoted, and anticipations are that \$7 per ton at pit mouth will be the price ruling before the summer is over. Such coal in pre-war days ranged from \$1.50 to \$2 per ton at pit mouth.

As regards manufacturing enterprise, high fuel cost will mean high power production cost, making it incumbent that, while the latter cannot wholly be avoided, steps be taken to not only conserve it, when generated, to the fullest extent possible, but ensure that, in its transmission and application features, avoidable losses, such as friction, leakage and kindred forms of waste be taken care of. Installation of the most modern types of power generation equipment will also be more than ever essential in the coming time.

SELECTED MARKET QUOTATIONS

Being a record of prices current on raw and finished material entering into the manufacture of mechanical and general engineering products.

FIG IRON.

Grey forge, Pittsburgh	...\$38 95
Lake Superior, charcoal	
Chicago	...41 75
Standard low phos., Philadelphia	...75 00
Bessemer, Pittsburgh	...42 95
Basic, Valley furnace	...40 00
Montreal Toronto	
Middlesboro, No. 3
Cleveland, No. 3
Clarence, No. 3
Hamilton
Victoria

FINISHED IRON AND STEEL.

Per lb. to Large Buyers	Cents
Iron bars, base, Toronto	...4 75
Steel bars, base, Toronto	...5 00
Steel bars, 2 in. to 4 in. base	...6 00
Steel bars, 4 in. and larger base	...7 00
iron bars, base, Montreal	...4 75
Steel bars, base, Montreal	...5 00
Reinforcing bars, base	...4 75
Bessemer rails, heavy, at mill	...38 00
Steel bars, Pittsburgh	...3 75
Tank plates, Pittsburgh	...6 00
Beams and angles, Pittsburgh	...4 00
Steel hoops, Pittsburgh	...4 25
F.O.B., Toronto Warehouse.	
Steel bars, base	...5 00
Small shapes	...5 25
F.O.B. Chicago Warehouse	
Steel bars	...4 25
Bars, 2 in. and up	...4 40
Structural shapes	...4 50
Plates	...6 00

FREIGHT RATES.

Pittsburgh to Following Points	Per 100 lbs.	C.L.	L.C.L.
Montreal	23.1	31.5	
St. John, N.B.	35.1	45.5	
Halifax	35.1	45.5	
Toronto	18.9	22.1	
Guelph	18.9	22.1	
London	18.9	22.1	
Windsor	18.9	22.1	
Winnipeg	64.9	85.1	

METALS.

Montreal Toronto	
Lake copper	...\$37 00 \$29 00
Electro copper	...37 00 39 00
Castings, copper	...36 00 38 00
Tin	...56 50 56 00
Spelter	...12 50 13 00
Lead	...12 50 12 25
Antimony	...27 00 36 00
Aluminium	...70 00 68 00

Prices per 100 lbs.

PLATES.

Montreal Toronto	
Plates, 1/4 to 1/2	...\$7 50 \$7 50
Heads	...7 60 7 60
Tank plates, 3-16 in.	...7 60 7 60

WROUGHT PIPE.

In effect April 10, 1917.			
Per 100 feet—	Black	Galv.	
	Buttweld.		
1/8 in.	...\$ 4 50	\$ 4 00	
1/4 in.	...4 32	4 36	
3/8 in.	...4 32	4 36	
1/2 in.	...5 61	7 18	
3/4 in.	...7 02	9 14	
1 in.	...10 37	13 52	
1 1/4 in.	...14 02	18 20	
1 1/2 in.	...16 78	21 86	
2 in.	...22 57	29 42	
2 1/2 in.	...36 27	47 09	
3 in.	...47 43	61 58	
3 1/2 in.	...58 88	75 90	
4 in.	...69 76	89 33	
Lapweld		z	z
2 in.	...25 53	32 01	
2 1/2 in.	...28 02	38 26	
3 in.	...49 73	62 18	

3 1/2 in.	...60 72	78 66
4 in.	...71 94	93 20
4 1/2 in.	...83 82	108 60
5 in.	...97 68	126 50
6 in.	...126 70	164 56
7 in.	...166 60	213 00
8 L. in.	...175 00	225 80
8 in.	...201 60	257 80
9 in.	...241 50	308 80
10 L. in.	...224 00	286 40
10 in.	...288 40	368 70

Prices—Ontario, Quebec and Maritime Provinces.

WROUGHT NIPPLES.

4" and under, 60%.	
4 1/2" and larger, 55%.	
4" and under, running thread, 40%.	
Standard couplings, 4" and under, 50%.	
4 1/2" and larger, 30%.	

OLD MATERIAL.

Dealers' Buying prices.	
Montreal Toronto	
Copper, light	...\$22 00 \$22 50
Copper, crucible	...26 50 26 50
Copper, heavy	...26 50 26 50
Copper wire	...26 50 26 50
No. 1 machine composition	...22 50 22 00
New Brass clip-joints	...18 00 18 00
No. 1 brass turnings	...16 00 17 00
Heavy Melting steel	...19 00 16 00
Steel turnings	...8 00 5 00
Boiler plate	...18 50 10 50
Axles, wrought iron	
iron	...22 00 24 00
Rails	...17 00 18 00
No. 1 machine cast iron	...21 00 20 00
Malleable scrap	...15 00 11 00
Pipe, wrought	...12 50 9 00
Heavy lead	...9 00 10 00
Tea lead	...7 50 7 00
Scrap zinc	...9 00 10 00
Aluminium	...36 00 35 00

BOLTS, NUTS AND SCREWS.

Per Cent.	
Coach and lag screws	...30
Stove bolts	...55
Plate washers	...10
Machine bolts, 7-16 and over	...10
Machine bolts, 3/8 and less.	...20
Blank bolts	...10
Bolt ends	...10
Machine screws, fl. and rd. hd., steel	...27 1/2
Machine screws, o. and fil. hd., steel	...10
Machine screws, fl. and rd. hd., brass	...add 20
Machine screws, o. and fil. hd., brass	...add 25
Nuts, square, up to 1 in., net list.	
Nuts, hex., up to 1 in., net list.	
Copper rivets and burrs, list plus	...30
Burrs only list plus	...50
Iron rivets and burrs	...27 1/2
Boiler rivets, base 3/4 in. and larger	...\$6.65
Structural rivets, as above	...6.55
Wood screws, flat, bright	...72 1/2
Wood screws, O. & R., bright	...67 1/2
Wood screws, flat, brass	...57 1/2
Wood screws, O. & R., brass	...52 1/2
Wood screws, flat, bronze	...27 1/2
Wood screws, O. & R., bronze	...25

MILLED PRODUCTS.

Per cent.	
Set screws	...35
Sq. & Hex. Head Cap Screws	...30
Rd. & Fil. Head Cap Screws	...10
Flat 7/8 But. Hd. Cap Screws plus	...10
Pin. & Semi-fn. nuts up to 1 in.	...25
Pin. and semi-fn. nuts, over 1 in., up to 1 1/2 in.	...30
Pin. and semi-fn. nuts, over 1 1/2 in., up to 2 in.	...20
Studs	...10
Taper pins	...40
Coupling bolts, plus	...10
Planer head bolts, without fillet	...10
Planer head bolts, with fillet	...10 and 10
Planer head bolt nuts, same as finished nuts.	
Planer bolt washers	...net
Hollow set screws	...list plus 20
Collar screws	...list plus 30, 10
Thumb screws	...20
Thumb nuts	...65
Patch bolts	...add 40, 10
Cold pressed nuts to 1 1/2 in.	...add \$4.50
Cold pressed nuts over 1 1/2 in.	...add \$7.00

BILLETS.

Per gross ton	
Bessemer billets	...\$75 00
Open-hearth billets	...75 00
O.H. sheet bars	...77 50
Forging billets	...100 00
Wire rods	...85 00
F.o.b. Pittsburgh.	

NAILS AND SPIKES.

Wire nails	...5 00 4 95
Cut nails	...5 00 5 00
Miscellaneous wire nails	...60%
Pressed spikes, 3/4 diam., 100 lbs.	...5 20

MISCELLANEOUS.

Solder, strictly	...0 33
Solder, guaranteed	...0 35
Babbitt metals	...14 to 60
Soldering coppers, lb.	...0 53
Putty, 100-lb. drums	...4 00
White lead, pure, cwt.	...14 25
Red dry lead, 100-lb. kegs, per cwt.	...13 87
Glue, French medal, lb.	...0 25
Tarred slaters' paper, roll	...0 95
Gasoline, per gal., bulk	...0 31 1/2
Benzine, per gal., bulk	...0 30 1/2
Pure turpentine, single bbls., gal.	...0 69
Linseed oil, raw, single, bbls.	...1 40
Linseed oil, boiled, single bbls.	...1 43
Plaster of Paris, per bbl.	...2 50
Plumbers' oakum, per cwt.	...8 00
Packing, square braided	...0 27
Packing, No. 1 Italian	...0 32
Packing, No. 2 Italian	...0 25
Lead wool, per lb.	...0 15
Pure Manila rope	...0 29 1/2
Transmission rope, Manila	...0 37 1/2
Drilling cables, Manila	...0 32 1/2

POLISHED DRILL ROD.

Discount off list, Montreal and Toronto 25%

CARBON DRILLS AND REAMERS.

Per Cent.	
S.S. drills, wire sizes up to 52	...40
S.S. drills, wire sizes, No. 53 to 80	...25
Standard drills to 1 1/2 in.	...40
Standard drills, over 1 1/2 in.	...15
3-fluted drills, plus	...10
Jobbers' and letter sizes	...40
Bit stock	...40
Ratchet drills	...15
S.S. drills for wood	...40
Wood boring brace drills	...25
Electricians' bits	...30
Sockets	...30

Sleeves	...40
Taper pin reamers	...20
Drills and countersinks	...list plus 30
Bridge reamers	...40
Centre reamers	...10
Chucking reamers	...10
Hand reamers	...15

COLD ROLLED SHAFING.

At mill	...list plus 40%
At warehouse	...list plus 50%
Discounts off new list. Warehouse price at Montreal and Toronto.	

IRON PIPE FITTINGS.

Canadian malleable, A. add 10%; B and C, 10%; cast iron, 35%; standard bushings, 50%; beaders, 60; flanged unions, 40; malleable bushings, 50; nipples, 55; malleable lipped unions, 50.
--

SHEETS.

Montreal Toronto	
Sheets, Black, No. 28	...\$7 75 \$7 25
Sheets, Black, No. 10	...7 10 7 00
Canada plates, dull, 52 sheets	...7 00 7 00
Canada plates, all bright	...8 00 8 00
Apollo brand, 10 3/4 oz. galvanized	...7 25 7 25
Queen's Head, 28 B. W.G.	...7 75 7 75
Fleur-de-Lis, 28 B.W. G.	...7 45 7 35
Gorbals Best, No. 28	...8 25 7 50
Colborne Crown, No. 28	...8 00 6 75
Premier, No. 28 U.S.	...8 30 8 20
Premier, 10 3/4 oz.	...8 60 8 50

PROOF COIL CHAIN.

1/4 in.	...\$9 45
5-16 in.	...9 10
3/8 in.	...8 35
7-16 in.	...7 15
1/2 in.	...6 95
9-16 in.	...6 95
5/8 in.	...6 80
3/4 in.	...6 70
7/8 in.	...6 55
1 inch	...6 40

Above quotations are per cwt.

ELECTRIC WELD COIL CHAIN B.B.

1/4 in.	...\$15 50
3-16 in.	...11 70
1/2 in.	...8 40
5-16 in.	...7 40
3/8 in.	...6 25
7-16 in.	...6 25
1/2 in.	...6 25
5/8 in.	...6 25
3/4 in.	...6 25

Prices per 100 lbs.

FILES AND RASPS.

Per Cent.	
Great Western, American	...55
Kearney & Foot, Arcade	...55
J. Barton Smith, Eagle	...55
McClelland, Globe	...55
Whitman & Barnes	...55
Black Diamond	...45
Delta Files	...40, 5
Nicholson	...45
Globe	...55
Vulcan	...55
Disston	...55

COAL AND COKE.

Solvay Foundry Coke	...
Connellsville Foundry Coke	...
Yough Steam Lump Coal	...
Pittsburgh Steam Lump Coal	...
Best Slack	...
Net ton C.o.b. Toronto	

BOILER TUBES.		TAPES.		ANODES.		SHEETS, 3½ lbs. sq. ft.	
Size.	Seamless Lap-welded	Chesterman Metallic, 50 ft.	\$2 00	Nickel	.50 to .54	ft.	16 00 16 00
1 in.	Luffkin Metallic, 603, 50 ft.	2 00	Cobalt	1.75 to 2.00	Sheets, 4 to 6 lbs.	15 50 15 50
1¼ in.	Admiral Steel Tape, 50 ft.	2 75	Copper	.44 to .46	sq. ft.
1½ in.	Admiral Steel Tape, 100 ft.	4 45	Tin	.49 to .56	Cut sheets, ½c per lb. extra.	
2 in.	Major Jun. Steel Tape, 50 ft.	3 50	Zinc	.23 to .25	Cut sheets to size, 1c per lb. extra.	
2½ in.	Rival Steel Tape, 50 ft.	2 75	Prices Per Lb.			
3 in.	Rival Steel Tape, 100 ft.	4 45	COPPER SHEETS.			
3¼ in.	Reliable Jun. Steel Tape, 50 ft.	3 50	Montreal Toronto			
4 in.			Bars, ½ to 2 in. 55 00 53 00			
Prices per 100 feet, Montreal and Toronto.		WASTE.		Plain sheets, 14 oz.			
OILS AND COMPOUNDS.		White Cents per lb.		14x28 in., 14x60 in. 55 00 53 50			
Castor oil, per lb.	XXX Extra	20	Copper sheet, tinned,			
Royalite, per gal., bulk.	Peerleas	20	14x60, 14 oz. 60 00 54 25			
Palatine	Grand	19	Copper sheet, planished, 14x60 base. 64 00 60 00			
Machine oil, per gal.	Superior	19	Braziers', in sheets, 6x4 base 55 00 52 00			
Black oil, per gal.	X L C R	18	BRASS.			
Cylinder oil, Capital	Atlas	18	Brass rods, base ½ in to 1 in rd. 0 55			
Cylinder oil, Acme	X Empire	18	Brass sheets, 8 in. wide, 20 oz. 0 60			
Standard cutting compound, per lb.	Ideal	17	Brass tubing, seamless. 0 57			
Lard oil, per gal.	X press	16	Copper tubing, seamless. 0 58			
Union thread cutting oil antiseptic	COLORED.		PLATING SUPPLIES.			
Acme cutting oil, antiseptic	Lion	14½	Polishing wheels, felt. 2 10			
Imperial quenching oil	Standard	13	Polishing wheels, hull-neck 1 35			
Petroleum fuel oil	No. 1	13	Emery in kegs, American 06			
BELTING—NO. 1 OAK TANNED.		Popular	11¾	Pumice, ground 04			
Extra heavy, single and double	Keen	10¾	Emery glue 15 to 20			
Standard	WOOL PACKING.		Tripoli composition 04 to 06			
Cut leather lacing, No.1	Arrow	25	Crocus composition 07 to 08			
Leather in sides	Axle	20	Emery composition 08 to 09			
This list subject to trade discount for quantity.		Anvil	15	Rouge, silver 35 to 50			
RUBBER BELTING.		Anchor	11	Rouge, powder 30 to 35			
Standard	WASHED WIPERS.		Prices Per Lb.			
Best grades	Select White	12	LEAD SHEETS.			
at present is one of waiting, to see what developments will follow the plans of the United States Government when their war policy is definitely announced. The visit of the Allied representatives to the United States may have considerable bearing on the early future of both relations and industrial activities. At		Mixed colored	10	Montreal Toronto			
present a certain lull prevails following the rumor that is current regarding the intention of the Imperial authorities to discontinue the manufacture of large shells here in Canada.		Dark colored	09	Sheets, 3 lbs. sq. ft. \$16 00 \$16 00			
at present is one of waiting, to see what developments will follow the plans of the United States Government when their war policy is definitely announced. The visit of the Allied representatives to the United States may have considerable bearing on the early future of both relations and industrial activities. At		This list subject to trade discount for quantity.		Prices Per Lb. Unless Otherwise Stated.			

The General Market Condition and Tendency

POLITICAL developments in the United States continue to affect the situation in Canada, principally with regard to prices of iron, steel and metals. Uncertainty as to what the American Government may do in the way of regulating prices is the cause of the unsettled outlook, meantime prices of steel products continue to advance, due entirely to the question of supply and demand. Iron and steel bars and small shapes have advanced. Iron bars are now 4.75c, steel bars 5c, and shapes 5.25c. Higher prices on a number of other steel products are looked for in the near future, among which may be included rivets, nuts and bolts, plates and tubes. The pig-iron situation is unchanged with prices entirely nominal. The shortage of pig-iron is becoming daily more acute, as furnaces are in a sold-up condition and stocks are very low. The embargo on steel turnings and borings is again in force with the result that prices have been forced down, due to the restricted market and accumulation of supplies. Prices of copper and brass scrap have declined, but heavy melting and other steel scraps continue firm and in good demand. Non-ferrous metals, with the exception of lead are weaker in sympathy with the New York market. There is a lack of interest in the market on the part of consumers who are waiting developments. There is a feeling that the American Government may fix prices on its requirements, and thus tend to weaken the market and cause a decline in values. Copper has declined 1c per pound. The machine tool market is a little more active, with indications of a return to normal business.

Montreal, Que., April 23, 1917.—The political outlook still dominates the situation and an air of uncertainty pervades the general market. The industrial interests are still undecided as to the effect the changed conditions will have upon trade relations between this country and America, and the attitude

at present is one of waiting, to see what developments will follow the plans of the United States Government when their war policy is definitely announced. The visit of the Allied representatives to the United States may have considerable bearing on the early future of both relations and industrial activities. At

present a certain lull prevails following the rumor that is current regarding the intention of the Imperial authorities to discontinue the manufacture of large shells here in Canada.

Pig Iron

The Canadian pig iron market is practically unchanged, there being no market, so to speak, as producers are virtually out of the running. What iron is being produced here is entirely absorbed by the producers themselves. The American situation has again been subjected to a general advance, approximating \$1 per ton, more noticeably on foundry iron. The composite pig iron market shows an advance of 40 cents per ton.

Steel

The general situation is little changed from that of a week ago, but the constant rise to still higher price levels reflects the abnormal conditions that prevail in the steel branch. That various grades of steel and other commodities will go still higher is the unquestionable opinion of the trade, as these are not expected to suffer from any action of the producers in supplying the requirements of the American Government. While no apparent tendency has yet been shown by consumers to turn away from the ever advancing trend of price quotations, an undertone of perplexity is undoubtedly evident on the part of buyers as to where the tide is going to stop. The pressure on the mills continues to be as great as ever in the past, and it would only be by a sudden cessation of hostilities that the present strength of the steel market could be affected. Even this might not have an immediate effect

upon existing conditions, as the majority of orders placed for this year and well into 1918 have been accepted on a non-cancellation basis. It is not expected that the needs of the U. S. Government will materially affect the export of supplies to the allied countries. The possibility of a reduction in the quantity of heavy shells required from this side of the Atlantic may relieve the situation in steel billets; as a matter of fact, some producers in the States are looking forward to contracted tonnage being turned over to other forms of steel, as original contracts had a clause inserted to the effect that this option would be permitted at any time during the period of the contract. With the price of forging billets now at the century mark, a movement of this kind might prevent this class of steel from reaching a higher level. The Pittsburgh quotation on iron and steel bars has been advanced \$5 per ton, the price asked being now 3¼c per lb. The demand for plates is as insistent as ever; the requirements for cars have fallen off, but this is more than balanced by the ever increasing inquiry for ship plates, the activity in this direction marking developments in shipbuilding that tend to dispel any possibility that prices on this class of steel will experience any sudden collapse for many months to come. The increasing cost of raw materials and also the heavier demand for all kinds of sheets has again resulted in a general advance on these products; the most recent quotation from the Pittsburgh mills indicate an advance of approximately \$20 per ton on tin mill black and black sheets, this week's quotation being 7c per lb. Blue annealed sheets on an advance of 1¼c are now quoted at 6¼c. While these sharp advances have somewhat discouraged buyers, sales show relatively little falling off. Galvanized sheets are now quoted at 9c Pittsburgh, an advance on the week of \$30 per ton. The action of the American Government in requesting a larger supply of tinplate from the sheet mills, is largely responsible for this sudden advance in the price of sheets. While the demand for railroad spikes is not exceedingly heavy, the higher cost of semi-finished steel has necessitated an advance in price, this being about \$4 per ton. The expected rise in wire products has become effective by some of the large mills, and will likely become general within a short time. The recent advance is \$6 per ton, the Pittsburgh prices being \$3.45 for plain wire, \$4.15 for galvanized wire, \$3.50 for wire nails, and \$3.65 for painted barb wire. Three points have been taken from the discount on wire fencing, the present discount being 48 per cent. The supply of wire rods is gradually decreasing owing to the fact that producing mills are using more and more of their own product for the making of wire and wire nails. This will eventually mean higher prices on these products. Inquiry for wrought iron pipe and boiler tubes continues very heavy, and a higher market is not unlikely. A pleasing condition arising out of the better transportation

facilities is the increased shipments of coke from the ovens to the blast furnaces, resulting in a lessening of the demand and an easier market. New York reports a decline of 50c per ton on both furnace and foundry, the respective prices being \$8 and \$10.50 per ton. The local situation is much the same, but with a much stronger undertone. Dealers anticipate higher prices within a short time if present conditions continue, but the general market is unchanged from that of a week ago. Securing of supplies is as difficult as ever, despite the fact that railroad transportation is much better, the dominating feature being the inability to obtain material from the mills.

Metals

No unexpected feature has developed in the metal market; with the exception of tin and lead, the general situation is showing weakness. Until the working policy of the United States has been announced it is the general opinion that a more or less unsettled condition will be apparent. This factor of the present market tends to uneasiness among dealers and consumers, resulting in an inactive demand for the various metals.

CANADIAN GOVERNMENT PURCHASING COMMISSION

The following gentlemen constitute the Commission appointed to make all purchases under the Dominion \$100,000,000 war appropriation:—George F. Galt, Winnipeg; Hormidas Laporte, Montreal; A. E. Kemp, Toronto. Thomas Hilliard is secretary, and the Commission headquarters are at Ottawa.

Future inquiry for copper is light, and, owing to the fact that consumers are fairly well covered for first half requirements, the present market is quiet. Tin is maintained in a strong position owing to the ever present risk that vessels are subjected to in bringing metal to this country. Activity on the part of spelter producers has developed a weak market. Lead is very strong, with independents asking higher prices. Antimony is in less demand and consequently weaker. Aluminum is strong and firm.

Copper.—During the past six weeks the price of metal has shown a decline of approximately 5c per lb. This has largely been caused by the action of the large producers in offering the American Government all the metal they require at a much lower figure than that prevailing on the open market. Coupled with this situation is the fact that consumers are still assuming a waiting attitude, as conditions still tend to uncertainty regarding early future movements. The fact that the greater portion of the first half of 1917 requirements had been contracted for before the beginning of the year leaves the buying element in a position

where they can temporarily await developments. In the meantime the market continues to weaken and prices are becoming easier. London reports a decline on all grades, while New York quotations are 1½c lower than last week, the nominal prices being 32c for lake, 31½c for electrolytic, and 28½c for castings. Local quotations are lower, dealers having reduced their prices 1c per lb., the prevailing figures being 37c for lake and electrolytic, and 36c for castings.

Tin.—War rumors to the effect that the United States Government is contemplating the placing of a tax on pig tin has created considerable excitement on the general market. While the freer granting of shipping permits were expected to follow the American war declaration, little relief has been noticed in this connection, but with the gradual formation of a closer co-operative policy this question is expected to receive early attention. A higher market prevails both in London and New York, the latter quotation being 55¼c per lb., this price being ¾c stronger than a week ago. A stronger air pervades the local situation with prices advanced 1½c, the dealers' quotation being 56½c per lb.

Spelter.—The market has been marked by the inactivity of buyers, and with sellers trying to make sales, the situation has developed a weak tendency. Should the dullness continue, still lower prices are anticipated by producers. London is easier and New York is quoting ½c below that of a week ago, the current nominal quotation being 9¼c per lb. The quotation on the market here of 12½c represents a decline of 1½c per lb.

Lead.—Firmness features the general lead situation, and this will likely prevail until definite arrangements have been made by the American Government regarding their future requirements. The strength of the situation is also partly due to the action of some producers in refraining from placing surplus supplies upon the market, keeping the metal for early contingencies. The general demand continues fairly heavy, but the present supply is not over abundant. The London situation is firm, with the New York market slightly stronger, the price quoted by independents being ¼c higher than last week, the current quotation being 9¾c per lb. Dealers here continue to quote 12½c on a very strong market.

Antimony.—With a falling off in the demand and the better supply, this metal has developed an easier tendency, and prices have consequently declined. The market is evidently influenced by the uncertain political situation. On a 1½c decline, New York is quoting the nominal price of 34c per lb. Locally the price has declined 1c per lb., the current quotation being 27c.

Machine Tools and Supplies

The machine tool trade has experienced one of the dullest weeks of any during the past few months. The apparent easing off in the demand for shell equipment has resulted in a stagnant situation. The report that the manufacture of the larger sizes of high explosive

shells will be discontinued has affected the market to the point where the demand for the heavier tools has become an obsolete factor in the business of machine tool dealers and builders. Present indications seem to be that a quiet spell may feature the early future of this industry. Dealers here report a very quiet week, with practically no inquiries. The demand for all classes of supplies continues very good, although prices are constantly moving upwards. High speed steel is still active, with the price ranging around \$2.50 per lb. The uncertainty that prevails among the makers of the larger shells has resulted in a falling off in the demand for supplies in this direction.

Scrap

The present situation is uncertain; dealers are influenced by the unsettled conditions, and it is difficult to state just what scrap is worth. Prices have fluctuated during the week, but are held generally on much the same basis as last week. Metal scraps, such as copper, brass and zinc, are developing a downward tendency, while steel and iron scraps are comparatively strong, with the trend in an opposite direction. With local conditions much the same as last week, dealers are firm on last week's prices.

Toronto, Ont., April 24.—The statement recently issued by the Imperial Munitions Board is striking evidence of what the munition industry has done for Canada. The total expenditure up to March 30, is \$543,000,000 while the value of munitions shipped up to that date is \$470,000,000. The total value of orders received by the Board is \$850,000,000. This activity and the remarkable developments in the steel industry, with which it is closely allied, are responsible more than anything else for the very satisfactory financial and industrial conditions now prevailing in Canada.

Steel

Although prices of steel continue to advance there is some difference of opinion as to the ultimate effect of the influences created by United States entering war, principally by reason of the concessions to the Government by the steel makers. Developments in the U.S. market are being followed closely by the steel trade in Canada, as interests here will be affected beneficially or otherwise by higher or lower prices in the States. In the meantime the trend of prices continues in an upward direction, and in view of the pressure of business at the mills, further advances seem to be the logical result of prevailing conditions. Although bars and small shapes are coming forward in better volume, deliveries on plates and sheets are more backward than ever. A report from Hamilton states that the Steel Company of Canada has closed down a bar mill owing to a let-up in demand for rounds for shells. It is understood that the company is shipping billets to England, in which case there will be no falling off in tonnage output.

Iron and steel bars and small shapes have advanced 25c, and are now quoted as follows:—Iron bars 4.75c, steel bars 5c, and small shapes 5.25c. A leading interest in the United States has announced an advance of \$6.00 a ton on all wire products, which will no doubt be followed by higher prices here. An advance in prices on nuts, bolts, and rivets, is also probable in the near future. Makers of iron and steel tubes are sold up for a year or more and are not quoting on new orders. The abnormally heavy demand for ship plates continues, and prices have an upward tendency. Wrought pipe is very firm at the recent advance and makers complain of a scarcity of raw material.

Black sheets continue very firm with indications of higher prices. The new demand for all grades of sheets is considerably greater than the mills can supply. To make the situation worse, production is only about 80 per cent. of capacity and the mills consequently are getting behind on deliveries. The difficulty of getting raw materials is the principal reason for the decrease in output.

The situation in the steel trade in the States is somewhat unsettled although prices are still going up due to the steady increase in demand. The U.S. Government requirements are increasing daily and must continue to do so for an indefinite period. The problem of how to meet the enormous demands for raw and finished steel products is being practically left to solve itself. Tank plates are now being quoted at 6c, and shapes 4c Pittsburgh.

Pig Iron

The situation in the pig iron market is unchanged. A firm quotation on domestic pig iron is practically unobtainable owing to the unsettled conditions prevailing. Hamilton pig iron is off the market and there is very little Victoria iron to be had. At Buffalo the situation is very tight; little iron is being offered at current prices because the output of furnaces is almost completely taken up for the rest of the year. For delivery this year, prices ranging from \$42 to \$45 are being quoted on pig iron covering the lower to the higher grades.

Scrap

The embargo which hitherto had been placed on the export of steel scrap now includes steel turnings and borings. The result has been a sharp decline in prices of this material to \$5 per ton owing to the anticipated accumulation of supplies which cannot in the meantime find a market. The situation will be relieved when the steel plant on Ashbridges Bay is in operation. Heavy melting steel, boiler plate and old rails, are firm and in good demand, as is also No. 1 machinery cast iron. Scrap copper and brass are weaker and prices have declined approximately 1c per lb.

Machine Tools

The machine tool market is gradually assuming a more normal aspect although no great activity is apparent. While the demand for machine tools for

munitions plants is now comparatively light, other business is picking up and developments in this regard are looked for. The machine tool market in the States is unsettled owing to the uncertainty with regard to Government requirements. There appears to be a possibility of munitions plants in the States being started up again which would mean a return of the former activity in the machine tool trade. This in time would affect deliveries of machinery to Canada. In the meantime lathes are fairly easy to obtain but deliveries on tool room equipments are very backward.

Supplies

Conditions in the machine shop supply business are improving although prices on most lines continue high. Supplies are now readily obtainable and there is less delay in getting materials than was the case a few months ago. Business generally is nearer normal than it has been for sometime. Gasoline is unchanged in the meantime although the recent advance of 5c a barrel of crude oil may affect prices of gasoline and benzine. Linseed oil has advanced 10c and turpentine 3c a gallon.

Metals

The uncertainty in regard to the American Government's purchases of metals and the fixing of prices on its requirements has caused a weakness in the market. Copper, however, is the only metal which has declined so far, and the market is decidedly weak. Lead is the only metal that is showing any indication of strength, but the price is unchanged meantime. The tin market is unsettled on account of the difficulty of obtaining shipping permits. Spelter is dull and easy, as consumers are not showing any interest in the market.

Copper.—The market is weak and prices have declined. The sales of second-hand copper which have been made, and the persistence of consumers in withholding their orders until price reductions were made have been the principal causes of the weak tone in the copper market. Copper has declined 1c, and is now quoted as follows:—Lake and electrolytic 39c, and castings 38c per pound.

Tin.—Although tin continues to advance in London, prices in New York are unchanged. The outlook in the market in New York is unsettled owing to the difficulty which is being experienced in obtaining shipping permits from the British Government; as a result, tin is not coming forward in sufficient quantities to meet urgent demands, and consumers are becoming uneasy. Local quotations, 56c per pound.

Spelter.—The market is dull and easy, due to lack of interest by consumers. If the demand does not improve, lower prices are likely. Spelter is being quoted at 13c per pound locally.

Lead.—There is a fair inquiry for lead and the market is firm. The position of lead is a strong one, and higher prices are predicted, but in absence of buying demand, no advance has been made. Lead is quoted at 12.25c per pound.

Antimony.—The market is dull, and the demand for spot metal has fallen off. Prices are unchanged and nominal at 36c per pound.

Aluminum.—There is a fair demand for aluminum at unchanged prices. Local quotations, 68c per pound.

Sydney, N.S., April 19.—The conference regarding the coal shortage called by Sir George Foster on the 2nd April at Ottawa, was attended by representatives from all the coal companies of Nova Scotia. The two important factors disclosed were a shortage of labor at the collieries and a shortage of transportation facilities. The decline in the coal production is proportionate to the reduction in the number of workmen employed at the collieries, and no remedy is in sight, as there is absolutely no source from which new workmen to replace those who have enlisted can be obtained, unless the precedent set in France is followed and Asiatic workmen are introduced. It is hardly conceivable that this course will commend itself to anyone, though what the future may enforce cannot be foreseen. The difficulties of transportation arise from a shortage of shipping caused by Admiralty requisitions, and this affects chiefly the Dominion Coal Company. The mainland collieries have been hindered by the inadequate equipment and the very insufficient motive power of the Canadian Government railway, and it is understood an attempt is to be made to improve these conditions.

Coal Famine in Prospect

The prospects of the fuel supply of Montreal and its vicinity in the coming autumn and winter are not cheering from the consumers' viewpoint. The tonnage that will come from the Cape Breton collieries is really negligible compared with previous seasons. The shortage of bottoms on the Great Lakes and the proved inability of the railways to transport the tonnage of coal required by Quebec and Ontario will prevent the sending of an adequate coal supply to these provinces, and there is apparently no way of averting a more pronounced coal famine next winter than was experienced last winter. The price of coal will also continue to advance. A figure of over \$5 per ton is already being quoted for bituminous coal at the pit-mouth in Pennsylvania, and it may be confidently predicted that coal will be selling at \$7 per ton at the pit-mouth before autumn. When it is stated that the American coal which formerly sold in Montreal against Nova Scotian coal was bought at the pit-mouth at prices varying between \$1.50 to \$2 per ton, and that the transportation charges have increased in greater ratio than the price of the coal itself, some idea may be gathered of the altitude to which coal prices are likely to soar before next Christmas in that part of Quebec which formerly obtained its coal supply from the Maritime Provinces.

The Minister of Labor has definitely refused to grant a Board of Concilia-

(Continued on page 71).

Enlarged Canadian Trade Intelligence Service

Under the arrangement made by the Minister of Trade and Commerce with Sir Edward Grey in July, 1912, the Department of Trade and Commerce, Ottawa, is able to present the following list of the more important British Consulates whose officers have been instructed by the Foreign Office to answer inquiries from and give information to Canadians who wish to consult them in reference to trade matters.

BRAZIL—Bahia, British Consul. Rio de Janeiro, British Consul General.	NETHERLANDS—Amsterdam, British Consul.
CHILE—Valparaiso, British Consul General.	PANAMA—Colon, British Consul. Panama, British Vice-Consul.
COLOMBIA—Bagota, British Consul General.	PERU—Lima, British Vice-Consul.
ECUADOR—Quito, British Consul General. Guayaquil, British Consul.	PORTUGAL—Lisbon, British Consul.
EGYPT—Alexandria, British Consul General.	RUSSIA—Moscow, British Consul General. Petrograd, British Consul. Vladivostok, British Consul. Odessa, British Consul General.
FRANCE—Havre, British Consul General. Marseilles, British Consul General.	SPAIN—Barcelona, British Consul General. Madrid, British Consul.
INDIA—Calcutta, Director General of Commercial Intelligence.	SWEDEN—Stockholm, British Consul.
ITALY—Genoa, British Consul General. Milan, British Consul.	SWITZERLAND—Geneva, British Consul.
MEXICO—Mexico, British Consul General.	URUGUAY—Monte Video, British Vice-Consul.
	VENEZUELA—Caracas, British Vice-Consul.

Canadian Commercial Intelligence Service

The Department of Trade and Commerce invites correspondence from Canadian exporters or importers upon all trade matters. Canadian Trade Commissioners and Commercial Agents should be kept supplied with catalogues, price lists, discount rates, etc., and the names and addresses of trade representatives by Canadian exporters. Catalogues should state whether prices are at factory point, f.o.b. at port of shipment, or, which is preferable, c.i.f. at foreign port.

CANADIAN TRADE COMMISSIONERS.

ARGENTINE REPUBLIC—B. S. Webb, Acting Canadian Trade Commissioner, Reconquista, No. 46, Buenos Aires. Cable address, Canadian.
AUSTRALIA—D. H. Ross, Stock Exchange Building, Melbourne. Cable address, Canadian.
BRITISH WEST INDIES—E. H. S. Flood, Bridgetown, Barbadoes, agent also for the Bermudas and British Guiana. Cable address, Canadian.
CHINA—J. W. Ross, 13 Nanking Road, Shanghai. Cable address, Cancom.
CUBA—A. T. Quilez, Acting Canadian Trade Commissioner, Lonja del Comercio, Apartado 1290, Havana. Cable address, Cantracom.
FRANCE—Phillipe Roy, Commissioner General, 17 and 19 Boulevard des Capucines, Paris. Cable address, Stadacona.
JAPAN—E. F. Crowe, Acting Canadian Trade Commissioner, P. O. Box 109, Yokohama. Cable address, Canadian.
HOLLAND—P. H. Geleerd, Acting Canadian Trade Commissioner, Zuidblaak, 26, Rotterdam. Cable address, Watermill.
RUSSIA—C. F. Just, Canadian Government Commercial Agent, Alexandrinskaya, Plosh 9, Petrograd. L. D. Wilgresh, Canadian Government Commercial Agent, Bnkhgolza Ulitza No. 4, Omsk, Siberia.
NEWFOUNDLAND—W. B. Nicholson, Bank of Montreal Building, Water Street, St. John's. Cable address, Canadian.
NEW ZEALAND—W. A. Beddoe, Union Buildings, Customs Street, Auckland. Cable address, Canadian.
SOUTH AFRICA—W. J. Egan, Norwich Union Buildings, Cape Town. Cable address, Cantracom.
UNITED KINGDOM—Harrison Watson, Sub-division E.C., 2, 73 Basinghall Street, London, E.C., England. Cable address, Sleighbing, London. N. D. Johnston, Sun Building, Clare Street, Bristol. Cable address, Canadian. J. E. Ray, Central House, Birmingham. Cable address, Canadian. J. Forsyth Smith, 31 North John Street, Liverpool. Cable address, Cantracom. F. A. C. Bickerdike, 4 St. Ann's Square, Manchester. Cable address, Cantracom. J. Forsyth Smith, Acting Canadian Trade Commissioner, 87 Union Street, Glasgow, Scotland. Cable address, Cantracom.

CANADIAN COMMERCIAL AGENTS

AUSTRALIA—R. Millin, Royal Exchange Building, Sydney, N.S.W.
BRITISH WEST INDIES—Edgar Tripp, Port of Spain, Trinidad. Cable address, Canadian. R. H. Curry, Nassau, Bahamas.
NORWAY AND DENMARK—C. E. Sontum Grubbegd No. 4, Christiania, Norway. Cable address, Sontums.
SPAIN—J. F. Roberts, Care British Consulate General, Barcelona.

CANADIAN HIGH COMMISSIONER'S OFFICE

UNITED KINGDOM—W. L. Griffith, Secretary, 17 Victoria Street, London, S.W., England. Cable address, Dominion, London.

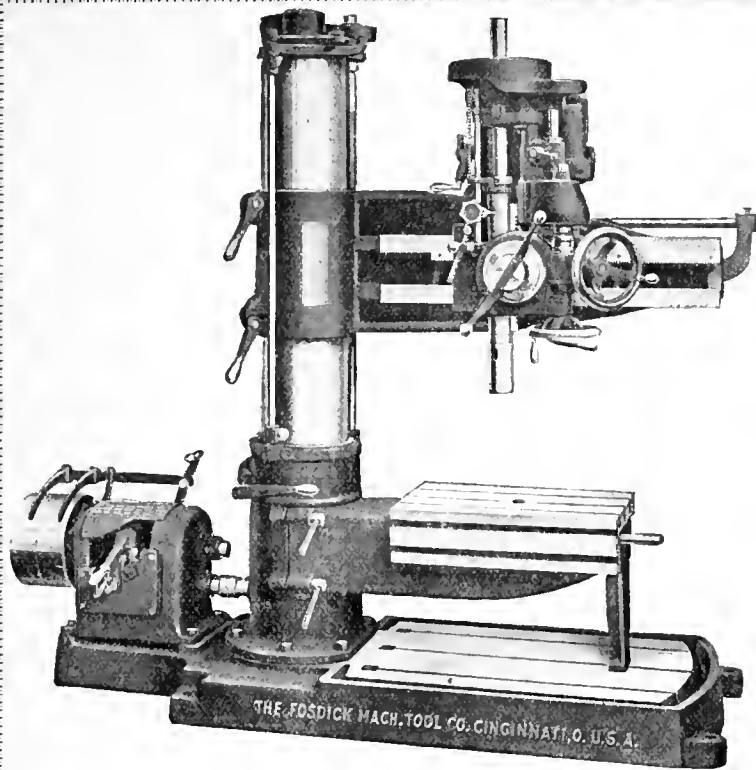

FOSDICK Heavy-duty RADIALS

Will materially increase your production and decrease your manufacturing costs.

Built in two styles, eight sizes, 2 to 6 foot arm.

Speed Box—Cone Pulley or Motor Drive.

Get Catalog and Study Its Money - Saving Features.

Early Deliveries.

The A. R. Williams Machinery Company, Limited

ST. JOHN, N.B.
WINNIPEG, VANCOUVER

"If It's Machinery, Write Williams"

64 Front Street West
TORONTO

This Geometric Die Head

is making good in a United States Navy Yard. (4½-in. size, Style "D.") It was selected because it was known that it would make good.

One thread is as readily cut as another in a Geometric Self-opening Die Head, because the Head is built for the Thread.

Long threads or short, heavy or light work, large diameters or small, fine threads or coarse—they are all alike to the Geometric Die Head.

Whatever the make of your Screw Machine, a Geometric Self-opening Screw-cutting Die Head can be furnished to fit it. Take up your threading propositions with us.

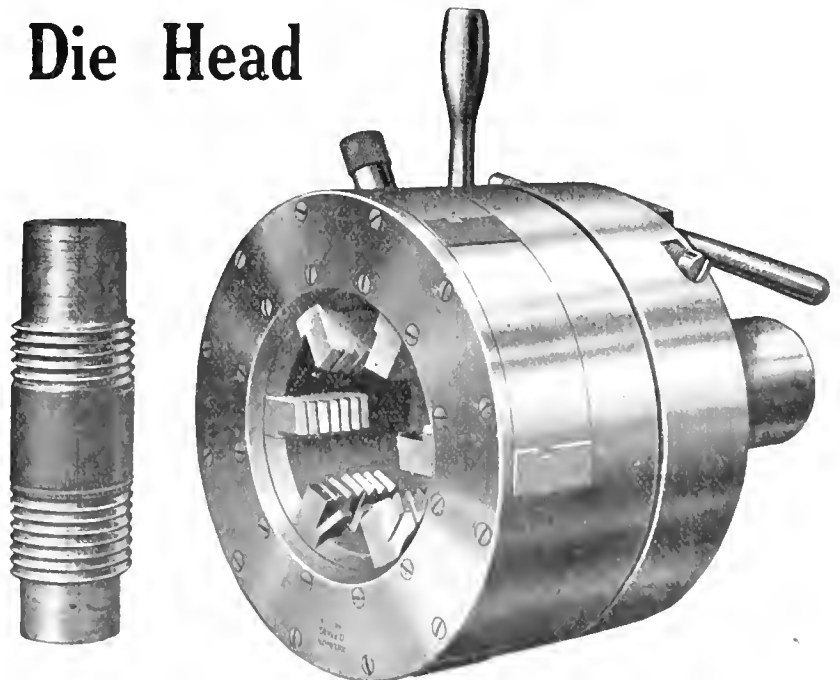

The Geometric Tool Company, New Haven, Conn., U.S.A.

Canadian Agents:

Williams & Wilson, Ltd., Montreal. The A. R. Williams Machinery Co., Ltd., Toronto, Winnipeg, St. John, N.B.

If any advertisement interests you, tear it out now and place with letters to be answered.

INDUSTRIAL ^A_D CONSTRUCTION NEWS

Establishment or Enlargement of Factories, Mills, Power Plants, Etc.; Construction of Railways, Bridges, Etc.; Municipal Undertakings; Mining News

ENGINEERING

London, Ont.—The Ford Motor Co., propose building an extension to their local plant.

Hamilton, Ont.—The Dominion Steel Foundry are building an addition to their plant.

Midland, Ont.—It is understood that a copper smelting plant will be established here by the International Copper Co. The old blast furnace is being taken down.

Oshawa, Ont.—An extension to the McCullough Brass Foundry is contemplated this summer. A site has been purchased adjoining the plant on the Ritson road.

Three Rivers, Que.—The St. Maurice Lumber Co., propose to erect a power house for six units of 10,500 h.p. and a concrete dam 1,080 feet long. R. F. Grant is manager.

Hamilton, Ont.—The Steel Company of Canada has decided to erect a by-product coke plant. Plans are being prepared, and it is understood construction will start at an early date.

St. Catharines, Ont.—The Globe Shock Absorbing Co. of Canada, which was organized less than a year ago to manufacture a patent automobile tire, has purchased the old Russell-Jennings factory on Vine street, and will immediately begin the work of enlarging the building and installing new machinery.

Amherstburg, Ont.—The Solvay Process Co. have awarded a contract to the Canadian Bridge Co. for constructing a building here which will be 278 x 192 feet by 80 feet high. The building will be used for housing a number of large tanks. Gordon S. Rutherford is the manager of the local plant.

Port Hone, Ont.—The Nicholson File Co., of which E. M. Thurber is manager, and which has been running night and day to its full capacity on war orders, is desirous of increasing the size of its plant, and wants a fixed assessment of \$35,000 for 10 years. It is stated that the monthly pay roll is about \$11,000, and the proposed enlargement would increase it by \$3,000 or \$4,000 per month in wages, as a considerably larger number of men would be employed.

GENERAL

Woodstock, Ont.—The Standard Tube & Fence Co. propose to erect an addition to their factory.

London, Ont.—It is reported that a company propose to establish a plant here for making rubber goods.

Hamilton, Ont.—The Chipman-Holton Knitting Co., are building an extension to their factory to cost about \$50,000.

Simcoe, Ont.—Fire, which broke out on April 18 in the east wing of the can-

plant of the Dominion Cannery, Ltd., here, gutted the entire top storey, entailing an estimated loss of \$50,000.

Toronto, Ont.—Scythes & Co., 22 Church Street, will build a two-storey brick factory for the manufacture of cordage to cost \$20,000.

Winnipeg, Man.—The Dominion Tar & Chemical plant at Transcona, which has been closed down since the beginning of the war, is shortly to resume operations. It is understood the company has just entered into a large contract for creosoting.

Cookshire, Que.—The Imperial Wax Paper Co., a recently incorporated concern, will establish a plant here for making waxed paper by a new process, for which the company has secured the Canadian rights. J. L. McNichol, at present on the staff of McGill University, Montreal, is manager of the company.

Port Arthur, Ont.—Barnett-McQueen, elevator contractors and builders, have been awarded the balance of the contract for the completion of the new 2,500,000 bushel elevator for the Western Terminal Elevator Co. The contract calls for an expenditure of over one million dollars.

Calgary, Alta.—Elevator companies are planning to construct this spring a large number of new storehouses in this province. The Alberta Farmers' Co-operative Co. propose to build 40 new elevators in the province to reach from the Peace River to the southern boundary. The cost of the elevators is placed roughly at \$350,000, and the capacity will run all the way from 35,000 to 65,000 bushels each.

Harrow, Ont.—A by-law will be submitted to the electors of Colchester South to be voted on April 30, asking that John Wall & Co., who are proposing to erect a canning factory in the village of Harrow, be exempt from taxation for a term of ten years. In the event of this by-law receiving the required number of votes, the company will commence work on the new factory at once.

Montreal, Que.—Fire on April 20 did approximately \$125,000 damage to a factory building on the corner of Nazareth and Brennan streets. The damage to the Independent Silk Co. will amount to \$100,000, as much dye, machinery, raw and prepared silks were destroyed. The Montreal Spinning Co., which occupies the second floor, estimates its loss by water at \$25,000. The Robert Gardiner Co., who manufacture machinery on the first floor, suffered little damage owing to the splendid work of the Salvage Corps.

MUNICIPAL

Three Rivers, Que.—The City Council propose to instal a waterworks system here.

Hull, P.Q.—The Provincial Board of

Health, have ordered the city to install a six million gallon mechanical filtration plant without delay.

Kincardine, Ont.—A by-law will be voted on by the ratepayers on May 15 to authorize a loan of \$20,000 to J. B. Watson, who proposes to establish a furniture factory.

Aylmer, Ont.—The ratepayers will vote on a by-law on April 30 to authorize the raising of \$22,000 for remodelling the electrical distribution system, and \$7,000 for installing an electrically driven fire pump.

Hamilton, Ont.—The Board of Control will adopt a joint report from City Engineer Gray and Waterworks Engineer Bain recommending that additional steam and electric units be installed at the beach pumping house. A resolution has been passed calling on the Board of Control to finance the carrying out of the recommendations, which will invoice an expenditure of approximately \$107,000.

TENDERS

Yorkton, Sask.—Tenders will be received until April 30 for one 350-400 b.h.p., combined Diesel electric unit. Specifications may be obtained from F. J. Pilkington, town clerk.

Adamsville, Que.—Tenders will be received up to May 1 for construction of a steel bridge, one span 125 feet, and abutments for same. Plans and specifications can be obtained from O. Landry, Sec.-Treasurer, Adamsville.

Montreal South, Que.—Tenders will be called some time in April for a 30-h.p. motor-driven turbine pump and a 150-h.p. gasoline engine-driven turbine pump for fire purposes, etc. E. Drinkwater, St. Lambert, Que., is the engineer.

Toronto, Ont.—Tenders will be received up to May 5, for supply of approximately 100 tons of pure soft pig lead for the York Township. Further information may be obtained at office of Township Engineer, Frank Barber, Toronto.

Edmonton, Alta.—Tenders will be received up to May 1 for the supply of automobile markers for the Province of Alberta, during the year 1918. Specifications may be obtained on application to the Deputy Provincial Secretary, Edmonton, Alta.

Sherbrooke, Que.—Tenders are being called for 30 miles of copper wire, six transformers and other material for a transmission line to Two Mills Falls power plant. Full information may be obtained from J. R. McGregor, electrical superintendent, Sherbrooke.

Toronto, Ont.—Tenders will be received at this Department until May 1, for the erection of a Creamery Building in New Liskeard. Plans and specifications can be seen at the office of the

Steels

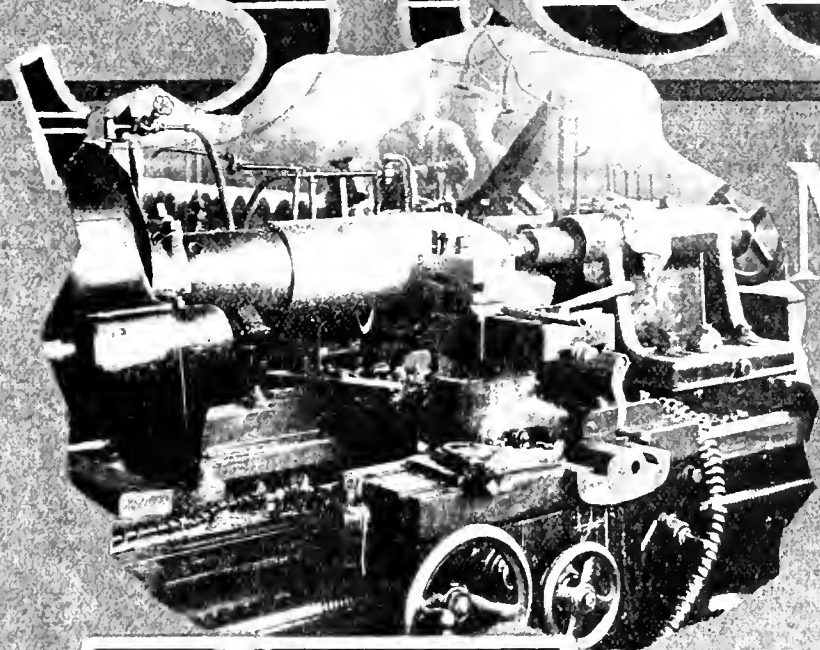

MOHAWK
Extra
High Speed
STEEL

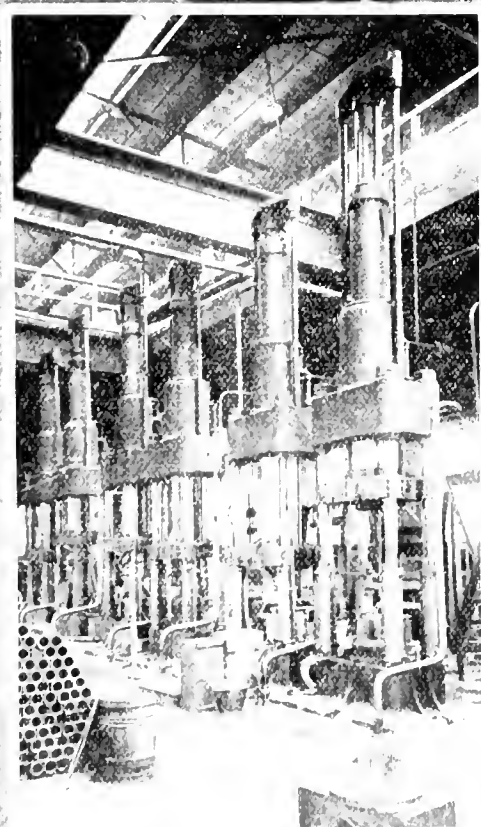

For its use in cutting, grinding, reaming, boring, and other operations.

It is especially adapted for the demands of the modern machine tool industry.

MOHAWK

Inferior tools and good mechanics don't co-operate—



In other words, you cannot get an A-1 production from a good man if you don't supply him with the best tools.

You will be sure of getting topnotch file efficiency if you supply your mechanics with

"DELTA" FILES

Delta Files fairly eat the metal, and they hold their keen cutting edge longer than other makes—a fact that we can easily prove.

The "Delta" is the only line of files from 3 to 24 inches made absolutely of crucible steel, and their manufacture is guided by half a century's file making experience.

There is a shape and size to suit every requirement.

Our trade-mark (satisfaction - or - money - back-guarantee) is on every tang.

Sold by all reliable dealers.



DELTA FILE WORKS

PHILADELPHIA, PA., U.S.A.

CANADIAN AGENTS:

H. S. Howland, Sons & Co., Toronto;
Starke, Seybold, Montreal;
Wm. Stairs, Son & Morrow, Halifax;
Merrick-Anderson Co., Winnipeg
ALL LEADING JOBBERS

Agricultural Department, New Liskeard, and this Department, H. F. McNaughton, Secretary, Public Works Department, Toronto, Ont.

BUILDING

Bridgeburg, Ont.—The School Board is having plans and specifications prepared for a new school, which will cost about \$23,000.

Dundas, Ont.—P. H. Secord & Sons of Brantford, have been awarded the contract for erecting a new office building for the John Bertram & Sons Co.

Three Rivers, Que.—The work on the new quarter million dollar post office building, which had been discontinued owing to the war, has now been resumed, and the building is expected to be ready for occupancy about December 1. Contractor Jos. Bourque, of Hull, has been given the contract. Construction of the three municipal schools, the St. Phillippe, the Ste. Cecile schools, and Delasalle Annex, is progressing.

CONTRACTS

Windsor, Ont.—The City Council have awarded a contract to the Canadian Incinerator Co., Toronto, for the construction of an incinerator.

London, Ont.—The Canadian Allis-Chalmers, Ltd., Toronto, have been awarded the contract for the machinery for Hunt Bros.' new mill.

New Toronto, Ont.—The Town Council has awarded a contract to the Herbert Morris Crane & Hoist Co., Toronto, for a jib crane for the waterworks plant.

The John McDougall Caledonian Ironworks, Montreal, have been awarded the contract for motor driven pumping outfit by the town of Hawkesbury, Ont., at \$1,569.

New Toronto, Ont.—The contract has been awarded by the council to the Bawden Pump Co., Toronto, for a turbine pump direct connected to a six-cylinder Van Blerck gasoline engine; also for valves and pipe, amounting to about \$4,000. Sub-contract amounting to about \$1,000 was awarded for valves to the Chapman Valve Mfg. Co., Toronto.

Toronto, Ont.—Tenders for supply of valves and hydrants for the York Township water-works system were opened recently at a meeting of York Township Council. That of the Bawden Machine Co., Toronto, for 14 24-inch valves at \$355 each, and one 16-inch valve at \$200, was accepted out of five tenders received. The same firm put in the only tender for hydrants at \$68.65 each, with three-way foot pipes at \$16.25, and additional frost jackets at \$12. This tender was also accepted, subject to signing of a contract, approved by the township engineer.

RAILWAYS—BRIDGES

Toronto, Ont.—The Ontario Railway & Municipal Board have ordered the Toronto Street Railway to supply 200 additional cars.

St. Thomas, Ont.—The London and Lake Erie Transportation Co., operating between London and Port Stanley, has

offered to sell the portion of its line between St. Thomas and Port Stanley, eight miles, together with four cars, for \$168,000.

TRADE GOSSIP

The Chapmen Valve Mfg. Co., Toronto, have been awarded a contract for 24-inch valves for Price Bros., paper mill at Shippaw Falls, Que.

The Bawden Pump Co., Toronto, have received orders from the British Cordite Co., Nobel, Ont., for nine boiler feed pumps and two general service pumps, and from the Port Arthur Pulp & Paper Co., for eleven centrifugal pumps.

Stratford, Ont.—A reduction of \$2 per horse-power to municipalities, announced by the Hydro-Electric Commission, brings the Stratford price down to \$27. The local Commission proposes to reduce power and light rates accordingly.

Brantford, Ont.—A reduction of twenty per cent. in domestic, ten per cent. in commercial, and thirteen per cent. in power rates is announced by the Hydro-electric Commission here, meaning a net saving to the consumers for the year of \$9,000.

U. S. Steel Unfilled Tonnage.—The unfilled tonnage of the United States Steel Corporation on March 31st was 11,711,644 tons, an increase of 134,947 tons over the previous month, and breaking all previous records. The February tonnage was 11,576,697 tons, which was the previous high record.

Industry Census.—Sir George Foster, acting Premier, announces that a comprehensive census of Canadian industries will be taken for 1917 by the census and statistics office. The idea is to have the fullest possible data in hand with regard to industrial undertakings available for the period of reconstruction, which will follow the return of peace.

Competition for Canada.—Russia will become world's largest exporter of wood pulp for making paper, according to M. Ghambashidze, honorary secretary of Russo-British Chamber of Commerce, in an address to commercial men at Hull, England. He predicted that Russia would eventually utilize her vast forests for manufacture of wood pulp.

Output of Seal Oil Will Be Commandeered.—Advices from St. John's, Newfoundland, state that it is understood that the British Government will commandeer the entire output of seal oil in this colony this year. Glycerine extracted from the oil has been found valuable in the manufacture of explosives. As a result of the assured demand, the price for seal pelts still on the market has risen from last year's quotation of \$6 a quintal (112 pounds) to \$7.25.

Hamilton, Ont.—In order to provide for contemplated additions to the plant, the directors of the Canadian Shovel & Tool Co. have decided to increase their capitalization from \$150,000 to \$500,000. Official notification has been received from Ottawa, stating that the concern has been reincorporated with the increased capitalization. The directorate is composed of W. A. Holton, F. Skelton, W. E. Skelton, M. B. Holton, and L. J. Holton.

Trail, B.C.—Shipments of refined copper and zinc from the Trail refinery of the Consolidated Mining & Smelting Co. are said to be going forward at a favorable rate. Copper is being shipped at the rate of between twenty-two and twenty-three tons per day, while zinc is going forward at an average rate of thirty-two to thirty-three tons daily. The output of the refinery is contracted for by the Imperial Munitions Board.

Move Plant From U. S. to Canada.—The proprietor of a spruce sawmill in New York State, whose timber limits are exhausted, has notified the Department of Trade and Commerce, Ottawa, of his wish to move to Canada. He is prepared to establish a plant with an outfit of 80,000 feet per day and wishes to locate in a town, with good railway facilities and convenient to spruce timber limits that are on the market either for sale or lease.

Canada Steamship Earnings Unaffected.—The new British order requisitioning all vessels under the British flag is not expected to have any material effect on the earnings of the Canada Steamship Lines, as it is pointed out fully nine-tenths of the company's fleet are under charter to the French Government and are not available until next February at the earliest. A director points out that such being the case the new order will make little change in the revenue of the company.

Hamilton, Ont.—The Provincial Hydro-Electric Commission has consented to a fifteen per cent. reduction in the commercial lighting rates, thus enabling the Hamilton Hydro department to compete on more equitable terms with the Cataract Power Co. A reduction of twenty per cent. in power rates for manufacturing purposes has also been agreed to, which will make it possible for the department to undersell the private company in dealing with new industries.

First Train Runs Under Mountain.—The first electric locomotive ran through the Mount Royal Tunnel, Montreal, on April 16, from the west portal at Model City through to the Dorchester Street shaft. A complete track is now laid through the tunnel. It is single part of the road and double where two trains are to pass each other. A complete double track will be laid later. The inside of the tunnel is now virtually completed. As yet, only construction trains will be run under the mountain.

Railways Seek to Raise Rates.—The Canadian railroads are about to make application to the Board of Railway Commissioners for a 15 per cent. increase in freight rates, and also a 15 per cent. increase in passenger rates. The railway companies state that this action has been rendered necessary by in freight and passenger rates will not be sufficient to meet even the increased cost of fuel, not to mention a 90 per cent. staggering additions to operating expenses. These include an advance of about 100 per cent. in the price of coal, and in addition a duty of 53c per ton

WM. MUIR & CO., LIMITED
 Manchester, England.
 Machine Tool Makers.
 Specialties: Patent Puncher Slotting
 Machines, Milling Machines, Boring
 Machines.
 Agents: Messrs. Peacock Bros., 68
 Beaver Hall Hill, Montreal.
 Send for catalogue.

JOHN STIRK & SONS, Limited
 HALIFAX, ENG.
MACHINE TOOLS
 Agents—The A. R. Williams Mcy. Co., Ltd.
 Toronto, Winnipeg, Vancouver, St. John, N.B.

BERTRAMS LIMITED
 Engineers
 Sciennes, EDINBURGH
 PAPER MILL MACHINERY
 and
 MACHINE TOOLS for IRON WORKERS
 Catalogues offered to Purchasers.

WIRE SPRINGS
 OF ALL KINDS
 Machine Springs, Valve Springs, Automobile
 Cushion Springs, etc., of a quality that defies
 competition. Tell us your requirements. Send
 sample or specification for price.
JAMES STEELE, LIMITED
 GUELPH, ONTARIO

Quality is Highest—Not the Price
Dickow's Guaranteed 10-Inch Universal
 Index Centers
 You save from \$50 to \$125 on first cost,
 and many times that because of their
 simple construction
 and great ease of
 operation. They em-
 body the maxi-
 mum of accu-
 racy, simplicity
 and durability.

 Get the Original—Beware of Imitators
 Sold by all dealers. Write to-day for particulars
 Fred. C. Dickow, 35 So. Desplaines St., Chicago, Ill., U.S.A.

**Oil Tempered
 Steel Springs**
 —for every purpose
 and the best for each
 use.
 Special styles of all
 kinds to order.
**THE CLEVELAND
 WIRE SPRING
 COMPANY**
 Cleveland, Ohio
 U.S.A.

BOLTS
 Our large stock of
**Machine Bolts,
 Rivets and Washers**
 assures quickly filled
 orders and
 prompt shipment.
 One quality only—
 The Best.
 Send a trial order.
**LONDON BOLT &
 HINGE WORKS**
 London Ontario

Special Machinery
 MADE TO ORDER
**Mill Machinery, Engine Work
 Grey Iron and Brass Castings**
 TRY US FOR GENERAL REPAIRS
ALEXANDER FLECK, LIMITED
 (Vulcan Iron Works) OTTAWA, ONT.

The
“Dupont”
 PATENT
**Power
 Hammer**

 The strength, dur-
 ability, economy of
 power and simplicity
 of adjustment of the
 Dupont Power Ham-
 mer make it a decid-
 edly superior tool.
 Made carefully from
 carefully selected,
 high-class materials.
 Positively
 Guaranteed
 Seven sizes.
 With rams from 35 to
 300 lbs.
 Write for full details.
THE PLESSISVILLE FOUNDRY
 Plessisville, Que.
 Ontario and Western Agents:
 The General Supply Co. of Canada Ltd.
 Ottawa Toronto Winnipeg

PATENT ATTORNEYS

BABCOCK & SONS

ESTAB. 1877

PATENTS-TRADE MARK-DESIGNS
IN ALL COUNTRIES

Book "Patent Protection"—Free. Master of Patent Laws, Formerly Patent Office Examiner.

99 St. James St., - Montreal, Que.
Branches: Ottawa, Washington.

RESEARCH BUREAU

REPORTS BY EXPERTS ON SCIENTIFIC, TECHNICAL AND INDUSTRIAL DEVELOPMENT.

SPECIAL RESEARCHES ARRANGED.

PATENTS, TRADE MARKS, ETC.

HANBURY A. BUDDEN CABLE ADDRESS
712 DRUMMOND BLDG., MONTREAL "BREVET"

PATENTS

Fetherstonheugh & Co.
Patent Solicitors. Head Office,
Royal Bank Bldg., Toronto,
Ottawa Office, 5 Elgin St.
Send for our Plain Practical
Pointers. Copy of National
Progress, in which our patents
are advertised, mailed free.

PATENTS PROMPTLY SECURED

in all countries. Ask for our Investor's Adviser, which will be sent free.

MARION & MARION, 364 University St.

Merchants Bank Building, corner
St. Catherine St., MONTREAL, Phone Up. 6474
and Washington, D.C., U.S.A.

SPECIAL MACHINERY

GAUGES, FIXTURES, DIES
AND
PRECISION TOOLS

WE HAVE THE
MOST MODERN
EQUIPMENT
TO HANDLE
ANY CLASS OF WORK

CANADIAN DISTRIBUTORS FOR THE
**ALBANY PATENT ROTARY
PUMP**

Albany Pump Co.

16 Pearl St., TORONTO, Canada
Phone Ad. 2511 A. W. Bennet, Manager

on locomotive fuel entering Canada from the United States, and a 7½ per cent. surtax in connection with war revenue. They claim that the proposed increases cent. increase in the price of locomotives, 50 per cent. increase in passenger and freight cars, rails \$10 a ton more than formerly.

Ford Gives Tractor Patents to Britain.—Henry Ford, at the request of the British Government, has waived all patent rights on his farm tractor and has cabled the specifications to London, so that Great Britain can manufacture tractors for use in the British Isles and France. Announcement to this effect was made at the Ford Motor Co.'s offices, Detroit, Mich., recently. It is believed that the tractors will help to greatly increase farm acreage in the Entente countries. It also was announced that Mr. Ford hopes to have thousands of tractors ready for use in the United States and Canada by August 1. Mr. Ford's entire tractor plant, the same as his automobile factory, will be at the disposal of the United States Government.

"Imperial" Building for the C.N.E.—The Dominion Royal Commission appointed by the Imperial Government several years ago to investigate and report upon the resources of the Empire, has recommended to the British Government that a grant be provided for the erection at the Canadian National Exhibition, Toronto, of a permanent building for showing goods of the United Kingdom. An interim report of the Commission just received at the Parliament Buildings deals with the splendid work done by the Exhibition, and the needs for greater advertisement of British goods. Goods manufactured in the United States, the Commission found, are now given undue prominence compared with those of Canada's Mother Country. The Commission since its appointment, has traveled over the whole Empire.

Toronto Harbor Improvements.—Contracts amounting to \$600,000 for pierhead construction work have been awarded by the Toronto Harbor Commission. The work is split among three concerns—R. Weddell & Sons, Trenton and Toronto; Port Arthur Construction Co., and J. O. Roddick, Toronto. The three contracts will constitute the summer work on the harbor improvement, and call for the construction of crib substructures and concrete superstructure of the inner harbor wall from Bathurst street east to York street. The total distance is 6,000 feet, so each concern contracts to construct 2,000 feet of wall. Section No. 3, immediately east from Bathurst street, will be built by the Weddell concern; J. O. Roddick will construct centre section No. 4, and the last stretch of pierhead to York street will be put in by the Port Arthur Construction Co.

MARINE

Wellan Canal Open.—The Wellan Canal was opened at Port Dalhousie on April 18 for any traffic that comes. All

bridge and lock tenders have been put on duty.

Sarnia, Ont.—Work on the Northern Navigation Co.'s steamers Harmonic and Huronic is about completed. They have been thoroughly overhauled and repaired.

Victoria, B.C.—The auxiliary schooner Margaret Haney built by the Cameron-Genoa Mills Co., underwent a successful trial cruise on April 5 and is now preparing for a trip to Bombay, India, with a cargo of lumber.

Victoria, B.C.—At the plant of the Cameron-Genoa Mills Co., work on the fourth auxiliary schooner, the Esquimalt is progressing favorably and in a short time the builders will be able to announce definitely the date on which she will be launched.

Vancouver, B.C.—The G.T.P. liner Prince Rupert, which ran ashore on Glenn Island on March 23, was floated shortly after midnight, Saturday, April 21, and is now in the harbor of Prince Rupert. Temporary repairs will be carried out in order to strengthen her for the voyage to Esquimalt, where extensive permanent repairs will be carried out.

Sarnia, Ont.—The Collingwood, Owen Sound, Soo, and north shore ports of Georgian Bay route of the Northern Navigation Co., will not be opened this season owing to the inability of the company to secure a suitable boat. This was announced by E. W. Holton, general passenger agent of the company. Efforts have been made to secure a boat that would fit the service, but repeated failures have been reported.

Victoria, B.C.—The next auxiliary schooner to be launched at the Wallace Shipyards, North Vancouver, is the Jesse Norcross. Although the date for launching has not yet been definitely set, the vessel is practically all ready and it is expected that she will take the water before the end of the month. The Norcross will be the third schooner launched from the ways at Wallace shipyard No. 2 and she will be the fifth vessel afloat of the fleet of wooden ships building in the province.

Sarnia, Ont.—The Reid Wrecking Co., has sold its Canadian interests to the Canada Steamship Line. It is understood that the deal includes the tugs James Reid, Sarnia City and Smith, all powerful towing craft, besides the Sarnia docks and machine shops of the line. The eRids still have the Fischer and Manistique tugs and the dry-dock at Port Huron. The company has also sold the steamer Kongo to Muskegon parties, and her name will be changed to the Overland.

Government Buys Coal Steamers.—The Dominion Government through the Department of Railways and Canals has concluded the purchase of two steamers, the Drummond and the McKee, to be used in the coal-carrying trade between Sydney and Montreal. The ships, which are of substantial carrying capacity, were secured from the Algoma

Companies. Particular efforts are being put forth both to increase the coal production in Nova Scotia and to improve the carrying facilities.

Vancouver, B.C.—Construction operations on Walls & Co.'s marine ways on Hastings Townsite, has been commenced. The new slip will be 75 feet by 30 feet, and will accommodate an 80-foot vessel with a 10-foot draught. The plant will be fitted to receive repair work in about a month. The president of the company, P. Walls, has had twenty-eight years' experience in shipbuilding in the Old Country, the United States and Canada. He has been a resident of Vancouver for six years, and is well known here.

Extend Embargo on Shipping.—An Order-in-Council has been passed extending the measures taken previously by the Government for the conservation of shipping. The transfer of British ships was restricted and made subject to Government control last year following similar action by the Imperial Government. The embargo has now been extended to cover ship mortgages and mortgage transfer. This action like the first, follows an Imperial regulation.



Steel Shell Forgings or Billets of any size or weight will move any distance or about curves upon our specially constructed Gravity Carriers and Incline or Horizontal power devices. No labor required.

Canadian Mathews Gravity Carrier Co., Toronto, Ont.

INCORPORATIONS

The Vancouver Engineering Works of Vancouver, B.C., has been incorporated with a capital of \$1,000,000.

The North Shore Ironworks of Vancouver, B.C., has been incorporated with a capital of \$100,000.

Akerberg, Thomson & Co., of Prince Rupert, B.C., have been incorporated with a capital of \$45,000 to carry on a general engineering business.

Smelters, Ltd., has been incorporated at Ottawa, with a capital of \$45,000, to manufacture, smelt, refine metals of all kinds at Montreal. Incorporators are: Peter Bercovith, Ernest Lafontaine and Nathan Gordon, all of Montreal.

Perfect Machine Co. has been incorporated at Toronto, with a capital of \$40,000, to manufacture machine tools at Galt, Ont. The provisional directors are: Wesley Clark, John S. Rumble and William B. Call, all of Galt, Ont.

The Davis-Bournonville Co., has been granted an Ontario Provincial license to manufacture cutting and welding apparatus with a capital not to exceed \$40,000. The company's attorney is Thomas D. Sutherland of Niagara Falls, Ont.

Atlas Gas & Oil Co. has been incorporated at Toronto, with a capital of \$300,000, to acquire and develop oil and gas lands. Head office at Toronto, and provisional directors are: F. W. Sawtell, R. J. M. Gardner and W. N. Houle, all of Toronto.

The Solvay Process Co., has been authorized to carry on business in the Province of Ontario with a capital not exceeding \$40,000. The company will manufacture chemical products at Amherstburg, Ont. The Attorney is James S. Lovell of Toronto.

F. X. Truck & Auto Co. of Canada, Ltd., has been incorporated at Ottawa, to manufacture automobiles and motor

We Know

you are anxious to buy
Canadian Made
goods.

The Imperial

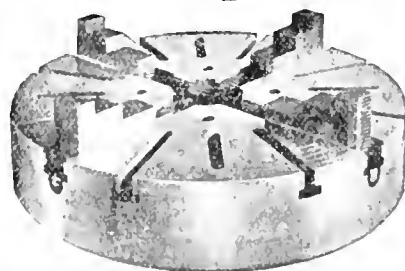

Chuck

is manufactured by
Ker & Goodwin
Brantford, Canada

METAL STAMPINGS

We are manufacturers of stamped parts for other manufacturers.

We do any kind of sheet metal stamping that you require. Our improved presses and plating plant enable us to produce the finest quality of work in a surprisingly short time.

We can finish steel stamping in Nickel, Brass or Copper.

Send us a sample order.

W. H. BANFIELD & SONS
372 Pape Avenue, Toronto, Can.

Cameron Babbitt Retainer

(Patented in Canada and the U.S.A.)

Not like clay or other material, as it does not stick to the work or hands. Does away with using leather or paste-board at end of box.

For any metal.

The only satisfactory compound for retaining molten metal and can be used over and over again for months—no deterioration.

For prices and samples apply to

A.S.K. Chemical Company, Elora, Ontario

PURO

(MADE IN CANADA.)

Saves Dollars

Why let that old-fashioned faucet go on year after year wasting water—MONEY? Why more drinking cups and glasses, only to become unsanitary—lost, broken or carried away? Puro Sanitary Drinking Fountain stops all this needless waste. Puro saves you 35% on the water bill alone. Puro saves you all that money you spend for cups. YET Puro is always ready with a clear, cool drink with dollars in the bank.

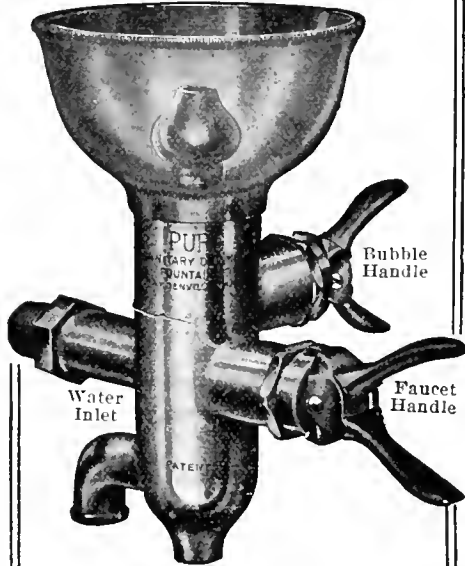

Puro Pays for Itself

You don't have to wait years to get back the small investment you have tied up in Puro equipment—You start cashing in at once—not only on your water bill saving, but on the increased efficiency of your workers as well. Men like Puro—it's clean. No danger of deadly germs lurking in its sparkling bubble. Write us—tell how many men, how many departments, and we'll tell you how much the cost will be to

“PURO - FY”

YOUR WATER SUPPLY

Puro Sanitary Drinking Fountain Company
147 University Ave., Toronto, Canada

trucks of all kinds at Walkerville, Ont. The incorporators are Stephen A. Griggs, Edwin H. Collins, and Elihu C. Griggs, all of Walkerville, Ont.

International Equipment Co. has been incorporated at Ottawa, with a capital of \$250,000, to manufacture and deal in all kinds of railway, marine and foundry supplies at Montreal. The incorporators are: Arnold Wainwright, Aubrey H. Elder, and D. Burley-Smith, all of Montreal.

Boat Releasing Gear of Canada, Ltd., has been incorporated at Ottawa, with a capital of \$226,000, to manufacture boat releasing gear and other appliances. Head office is at Montreal, and the incorporators are: Arthur R. Holden, Pierre A. Badeaux, and Arthur Charters, all of Montreal.

The Canadian Shovel & Tool Co., has been incorporated at Ottawa with a capital of \$500,000 to manufacture shovels, spades, railway field and mining tools of all kinds at Hamilton, Ont. The incorporators are William A. Holton, Frederick Skelton and Walter E. Skelton all of Hamilton, Ont.

The Mason Regulator & Engineering Co., has been incorporated at Ottawa with a capital of \$48,000 to manufacture munitions and to carry on the business of mechanical engineers at Montreal. The incorporators are Henri and Joseph Henri Gerin-Lajoie, and Alexandre Lacoste all of Montreal.

The W. E. Seagrave Co., has been incorporated at Ottawa with a capital of \$400,000 to manufacture fire engines and fire apparatus of all kinds at Walkerville, Ont. The incorporators are Warren E. Seagrave of Walkerville and George M. Mair and Alexander R. Bartlett of Windsor, Ont.

Roelofson Elevator Works, Ltd., has been incorporated at Toronto, with a capital of \$75,000, to manufacture hand, power, electric and hydraulic elevators at Galt, Ont. The provisional directors are: John F. Roelofson, Edward C. Codling and Harry Smith, all of Galt, Ont.

Independent Metal Co. has been incorporated at Toronto, with a capital of \$100,000, to manufacture metals and alloys of all kinds at Toronto. Provisional directors are: James J. MacLennan, John N. Black, and E. Corrigan, all of Toronto.

Niagara Motors.—Bulletin being distributed by the Niagara Motors Corporation, Buffalo, N.Y., dealing with an interesting line of gasoline motors for power boats. Specifications give the principal dimensions and weights, etc., of the various models, some of which are illustrated and their principal features described. A number of power boats are also illustrated featuring the suitability of “Niagara” motors for various kinds of service.

The Worker and the Works is the title of a booklet containing an historical sketch of the Westinghouse Electric and Mfg. Co.'s works at East Pittsburgh, Pa., and also describing the shop welfare work instituted by the company for the benefit of the employees. The Casino Technical Night School operated under the auspices of the company is also dealt with briefly. The illustrations show the night classes at work and also views of the works.

Searchlight Projectors.—An interesting catalogue has recently been issued by Crompton & Co., Chelmsford, England dealing with searchlight projectors for naval and military and general purposes. The catalogue contains a general description covering a wide range of sizes of standard searchlight projectors including particulars of the main features of their construction. The various types are illustrated and particulars given regarding current and range etc. of all sizes. The concluding pages contain information covering special attachments and applications.

BOOK REVIEW

Spon's Electrical Pocket Book.. By Walter H. Molesworth. 488 pages 6 3/4 x 4 1/4 ins., 325 illustrations. Published by E. & F. N. Spon Ltd., London and Spon and Chamberlain, New York City. Price \$1.75 net. This is a new reference book of general electrical information, formulae and tables for practical engineers. The book contains a great deal of useful information for electrical engineers arranged in compact form and written in a clear and concise manner. Some sections, namely, those devoted to essentially English practice such as British Board of Trade and Home Office Regulations, etc., will not be of much practical value in Canada, but as it is an English publication this feature could not be eliminated. It is however an excellent handbook and in all other respects will be a valuable reference book for engineers in almost any country. Being a pocket book, questions relating to design and detail have not been included, nor has space permitted of reference to telegraphy, telephoning and special branches of electricity. A useful feature is the inclusion of full metric conversion tables to satisfy the need created by the increasing adoption of metric weights and measures. The book has a synopsis of contents, a complete index comprising 20 pages and is bound in substantial cloth covers.

CATALOGUES

Safety Glasses.—Bulletin issued by T. A. Willson & Co., Inc., Reading, Pa., dealing with various styles of safety glasses for industrial uses. Each style is illustrated and described together with price lists of the glasses and extra parts.

Spraco Paint Gun.—The Spray Engineering Co., Boston, Mass., have issued a bulletin describing the “Spraco” paint gun for all kinds of painting. The principal features of this apparatus and attachments are illustrated and described accompanied by price lists of the complete equipments and also of the auxiliary apparatus.

THE IRON WORKS

LIMITED

Successors to

Owen Sound Iron Works

Owen Sound, Ont.

Engineers

Boiler-makers

Founders

Machinists

Tank Work
Smoke Stacks,
Grey Iron and
Brass Castings,
Special
Machinery
Made to
Order

THE SYDNEY LETTER

(Continued from page 442).

tion to the United Mine Workers of Nova Scotia, but has not yet announced his decision in the matter of the application of the Provincial Workmen's Association. The application of the Provincial Workmen's Association raises a nice technical point. This organization has stated it will not call a strike to enforce its demand for an increase in wages, as the members consider such action at the present juncture would be unpatriotic. This course of action is in every way commendable, but technically it defeats an application for a Board of Conciliation which is supposed to be granted only to prevent the calling of a strike. It would appear as if the Industrial Disputes Act could very usefully be extended to cover the procedure of investigation and conciliation, that has been so successful in the past, in this and similar cases where all that is needed is the tactful aid of some independent and unbiased tribunal to adjust the differences of two parties where the breach of opinion is not so wide as to threaten an actual strike. It is understood that a Commission is to be appointed to investigate the bearing of the increased cost of living on the earnings of the miners, and it is not anticipated that any trouble will occur.

Coal Production

Production at the collieries continues at about the same rate as during the past few months. No increase is being gained, but outputs have not declined materially. Some reduction of the working force is certain when warmer weather arrives, and farming and fishing commence. It is to be hoped the authorities will not permit the wholesale exodus of men from the province which took place last summer when the time for the harvest excursions arrives. The National Service Board will scarcely be able to condone the further reduction of the men employed in producing coal for the increase of the number to be employed in harvesting in the West. This would be a nice example of the procedure known as robbing Peter to pay Paul.



"Barnes-made" SPRINGS

are the result of over sixty years' experience in spring making, combined with unsurpassed equipment and the workmanship of men who have been with us, ten, twenty and in some cases thirty years.

Write for booklet No. 7-T.

Established 1857.
THE WALLACE BARNES COMPANY
 218 South St., Bristol, Ct., U.S.A.
 Mfrs of "Barnes-made" Products
 Springs, Screw Machine Products, Cold Rolled Steel and Wire

MAPLE LEAF
STITCHED COTTON DUCK
BELTING
DOMINION BELTING CO. LTD.
HAMILTON CANADA

Oxy-Acetylene Welding

We can give the best of service in all kinds of welding repair jobs. We have successfully repaired the most difficult jobs. Our work is high-class and our prices moderate.

Send us your work or write us regarding it.

TORONTO WELDING CO.
 26 Pearl St., TORONTO

"HAWK" D
CHROME
VANADIUM
STEEL



GAUGES
DIES, TOOLS AND REPAIRS
OXY-ACETYLENE WELDING
WORTH ENGINEERING CO.
 163 1/2 Spadina Ave., Toronto, Ont.
 Phone Adel. 3734
B. H. AYLSWORTH . E. HACKWORTH

Will
 Give You
 Exceptional

**Shell Forging
 Production**

WITHOUT AN EQUAL FOR
 BOTH FIRST AND
 SECOND OPERATION
 PUNCHES.

Comes to you heat-treated and ready for use.

It does not stick to the work.

There are many cases where each punch has turned out over 2,000 shells.

It means more shells, per machine per day.

STEEL OF EVERY DESCRIPTION.

**Hawkrige Brothers
 Company**

303 Congress St., BOSTON, MASS.
 U. S. A.

**MacKinnon, Holmes
 & Company, Limited**

Design, manufacture and erect all classes of Steel Work.

Specialties :-

- Bridges
- Oil and Water Tanks
- Penstocks
- Coal and Coke Bins
- Smoke Flues & Stacks.

Prompt deliveries assured.

Designs and Estimates from Head Office at

SHERBROOKE, QUE.

OVENS

Enameling and Varnishing Ovens heated by Gas, Electricity, Steam or Coal.
 Write for Booklet.

Brantford Oven & Rack Co., Ltd.
 Brantford, Canada.

MORTON MANUFACTURING CO.

PORTABLE PLANERS
 DRAW CUT SHAPERS
 SPECIAL DRAW CUT R R SHAPERS
 FINISHED MACHINE KEYS
 STATIONARY & PORTABLE KEY WAY CUTTERS
 SPECIAL LOCOMOTIVE CYLINDER PLANERS

OFFICE AND WORKS: MUSKOGON HEIGHTS U.S.A.

**TRY HAMILTON
 BABBITTS**

We Make Nothing Else

GEO. E. JOBBORN, Hamilton, Ont.

CLASSIFIED ADVERTISING

Rates (payable in advance): Two cents per word first insertion; one cent per word subsequent insertions. Count five words when box number is required. Each figure counts as one word. Minimum order \$1.00. Display rates on application.

SECTION

WANTED

WANTED—LATHE ABOUT 48" SWING OR larger, also boring mill up to 60". Must be in good order and reasonable price. Apply Box 288, Canadian Machinery. c16m

FOR SALE

1—GISHOLT LATHE 24" SWING, 6' BED. with turret head and three-jaw chuck. 1—Gisholt lathe, same as above, 20" swing, 6' bed. 1—4.5 Brown, Bogga marking machine. Jenckes Machine Co., Sherbrooke, Que. c20m

FOR SALE—ONE 450 H.P. THOMPSON & Williams condensing engine. Will sell cheap. Engine is in first-class repair and will give every satisfaction. Apply J. A. Marven, Limited, Moncton, N.B. tcfm

FORD-SMITH 18-PDR. SHELL GRINDER — complete and in perfect condition. To move quickly we will sell very cheap. M. Beatty & Sons, Ltd., Welland, Ont. c23m

2—SCREW-CUTTING ENGINE LATHES, 14" x 30", complete with countershaft, chuck, face plate, etc. Second-hand, but in good order. 1—Potter and Johnston automatic lathe. Apply The Jenckes Machine Company, Limited, Sherbrooke, Que. c18m

FOR SALE—TWELVE PRACTICALLY NEW No. 7-C Racine heavy duty high speed hack saw machines. Suitable for all cutting purposes. Immediate delivery. For price and further information address The Peck Rolling Mills, Limited, Montreal. c16m

ONE LATHE 16" x 4½" BACK-GEARED — Built by P. P. Silk Machine & Tool Co., Cincinnati, Ohio. One lathe 18" x 3", back-geared. Built by the Bradford Mill Co., Cincinnati, Ohio. Four Murchey collapsible dies. Capacity 1½" to 2½". Box 272, Canadian Machinery. ctmf

FOR IMMEDIATE SALE—1—75 H.P. ELYRIA gas engine; 1—40 H.P. Elyria gas engine; 1—75 Kw., 250-volt D.C. Western Electric generator, belted type; 1—45 Kw., 250-volt D.C. Crocker-Wheeler generator, belted type; 1—45 H.P., 220-volt Westinghouse motor. All in first-class condition; can be inspected in daily use. The Elyria Machine Co., Elyria, Ohio. c16m

WE OFFER THE FOLLOWING MACHINERY and tools at exceptionally low prices: 1—heavy duty Rockford drill, 2½", suitable for heavy work, in use only two months; 4—Jones & Lamson turret lathes, Bar machines, size 2 x 24; price \$200.00 to \$250.00 each. 2—Jones & Lamson turret lathes, chucking machines, size 2 x 24; price \$200.00 each. 1—Small turret lathe, 1¾ hole in spindle, 1¼ hole in turret head. 1—Two-spindle sensitive drill \$100.00. 2—Holden-Morgan thread millers, slightly used on 4.5 shells. 4—Bertram internal thread millers. 2—No. 9 Hartness dies capacity range 1¼ to 3" dia. 4—12" Whiton Universal scroll heavy duty chucks, 3-jaw. 1—10" Skinner Universal chuck, 3-jaw. 1—10 x 12 35 H.P. Robb horizontal steam engine, in first-class condition. Apply Steel Furnishing Company, Limited, New Glasgow, N.S. cow17

PLATING

WE CAN UNDERTAKE AT PRESENT TIME certain quantity of job plating of all kinds, at reasonable figures. Enquire for prices. Renfrew Scale Company, Renfrew, Ont. c18m

SPECIAL MACHINERY

MANUFACTURERS—WE CAN UNDERTAKE work to any specification—munition production equipment or otherwise. Write W. H. Sumbling Machinery Co., 7 St. Mary St., Toronto.

() E. WOODS—GENERAL MACHINE SHOP—builders of special machinery. Will do well to use our experience and equipment. We are prepared to make special machinery, punches and dies, jigs, fixtures and tools to any specifications and drawings. Get our price and promise of delivery. Phone Gerrard 960. Address 754 Broadview Ave., Toronto, Ont.

The same firms— time after time

sending in copy for this section is one of the most convincing proofs of its worth to anyone with machinery or machine shop equipment to dispose of.

These firms know a good thing when they see it—they have learned by using this section just what it can do for them.

Try it yourself! That lathe, drill or whatever it is, describe it fully and send in your copy to-day for next week's issue. You'll find that the frequent use of this section will help you dispose of equipment you have outgrown—get what you want in a hurry, whether it be men or equipment.

Canadian Machinery

Classified Advertising Section

143 University Ave., Toronto, Ont.

BUSINESS CHANCES

A PROSPEROUS AND GROWING FILE manufacturing business. The product is being sold to A1 trade, and the demand is unlimited. This business can be had outright, or the practical partner will remain. A stock company proposition would be considered. This proposition will bear the closest scrutiny. Box 296, Canadian Machinery. c17m

FOR SALE—A MEDIUM-SIZED TWO-STOREY brick factory situated in the best small city in Ontario. Buildings in good condition, suitable for either metal or wood-working; shipping facilities unexcelled. Two trunk lines; direct connections east, west, north and south. Educational advantages the very best. Plant will be sold at a bargain and on easy terms of payment, if desired. Apply Box 294, Canadian Machinery.

SITUATIONS WANTED

SUPERINTENDENT—PRACTICAL MECHANICAL man with 12 years' experience, last two years superintendent of shells, is open for a proposition. Box 289, Canadian Machinery. c16m

SUPERINTENDENT OR WORKS MANAGER of engineering concern will be open for an engagement about 1st of June. Am practical marine engineer with 22 years' experience. Have had 12 years' experience in handling men and am considered good organizer. Marine engine building preferred.—Box 295, Canadian Machinery. c17m

SITUATIONS VACANT

A GENERAL SALESMAN TO HANDLE OUR general lines in part of Ontario. Apply Box 290, Canadian Machinery. c16m

YOUNG MAN WITH GENERAL KNOWLEDGE — to take charge of our sample floor. Apply Box 291, Canadian Machinery. c16m

MECHANICAL ENGINEER WANTED—FIRST-class opportunity for the right party. Must be energetic, ambitious, sober and have some knowledge of French. Apply Box 286, Canadian Machinery. tcmf

PRODUCTION ENGINEER WANTED — TO take charge of cost reduction work in Canadian shop manufacturing air compressors, rock drills and other lines. State age, experience and salary expected. Box 292, Canadian Machinery. c16m

WANTED—A CANADIAN REPRESENTATIVE to handle complete line of electric furnace steel. Must be experienced in handling alloy and tool steels, and now in touch with Canadian trade. Best references required. Box 293, Canadian Machinery. c17m

A GOOD SALES ENGINEER TO OPEN OFFICE to sell Moline heat in Canadian territory. Must be a good salesman, having had a general heating and ventilating experience. Must give good references. We have a fine proposition for the right man. Address Moline Heat, Moline, Ill. ctmf

CANADIAN MACHINERY

AND MANUFACTURING NEWS

A weekly newspaper devoted to the machinery and manufacturing interests.

Vol. XVII.

TORONTO, MAY 3, 1917

No. 18

EDITORIAL CONTENTS

Production of Twist Drills in a Specialized Canadian Factory	443-446
General	446
Ball Bearings.	
Production Methods and Devices	447-450
Centering Shells. Reclaiming Nuts. Grinding Profile Cutters. Cutting Off Stock in the Miller.	
General	450
Embargo on Steel Turnings Export. Dominion Bridge Get Structural Steel Contract.	
Tool Holder and Cutting Tool Application Data—III	451-453
General	453
Increased Tax on War Profits. Big Increase in Dominion Trade.	
Spokes in Industry's Wheel	454-455
William Newman.	
General	455
Canada's Shell-Making Achievement. Submarine Construction on Pacific Coast.	
Editorial Correspondence	456-457
Machinists' Instruction Course—XIX. Doesn't Believe in Saving Time. Setting a Lathe in Position. Mistakes Through Verbal Instructions.	
Development of Wood and Steel Shipbuilding in Canada	458-461
Upper Lakes S.S. "Westmount" Launched. Auxiliary Power Schooner "Laurel Whalen" Launched. Trial Trip of Auxiliary Power Schooner "Margaret Haney."	
Progress in New Equipment	462-465
Combined Steam Turbine and Centrifugal Boiler Feed Pump. Triple Purpose Radial Drill. High-Speed Heavy Duty Cutting-Off Saw. Rennerfelt Electric Arc Furnace.	
Editorial	466
Objective of Munitions Scrap Conservation. The Big Shell Situation. Canada's 1917 Budget.	
Industrial Notabilities	467
Walter Baker Champ.	
Selected Market Quotations	468-469
The General Market Condition and Tendency	469-472
Montreal Letter. Toronto Letter. Sydney Letter. Canadian Railways Make New Record.	
Industrial and Construction News (Advtg. Section)	70-78

THE MACLEAN PUBLISHING COMPANY, LIMITED

JOHN BAYNE MACLEAN, Pres. H. T. HUNTER, Vice-pres. H. V. TYRRELL, Gen. Man.

Publishers of Hardware and Metal, The Financial Post, MacLenn's Magazine, Farmer's Magazine, Canadian Grocer, Dry Goods Review, Men's Wear Review, Printer and Publisher, Bookseller and Stationer, Canadian Machinery and Manufacturing News, The Power House, The Sanitary Engineer, Canadian Foundryman, Marine Marine Engineering of Canada.

Cable Address: Macpubco, Toronto; Atabek, London, Eng.

ESTABLISHED 1887

CANADIAN MACHINERY AND MANUFACTURING NEWS

PETER BAIN, M.E., Editor. B. G. NEWTON, Manager.
Associate Editors: A. G. WEBSTER, J. M. WILSON, J. H. RODGERS.

CHIEF OFFICES:

CANADA—Montreal, Southam Building, 128 Bleury Street; Toronto: 143-153 University Ave., Telephone Main 7321.
Winnipeg, 22 Royal Bank Building, Telephone Garry 2313.

GREAT BRITAIN—LONDON, The MacLean Company of Great Britain, Limited, 88 Fleet Street, E.C., E. J. Dodd,
Director, Telephone Central 12960, Cable Address: Atabek, London, England.

UNITED STATES—New York, R. R. Huestis, Room 620, 111 Broadway, N.Y., Telephone Reector 8971; Boston, C. L.
Morton, Room 733, Old South Building, Telephone Main 1204. A. H. Byrne, 1104-5-6-7 Fort Dearborn Bldg.,
165 W. Monroe St., Chicago, Telephone Randolph 3234.

SUBSCRIPTION PRICE—Canada, Great Britain, South Africa and the West Indies, \$3.00 a year; United States,
\$3.50 a year; other countries, \$4.00 a year; Single Copies, 15 cents. Invariably in advance.

First in the field—still in the lead

Improved Screw-cutting **HENDEY** Engine Lathe

12-inch Lathe

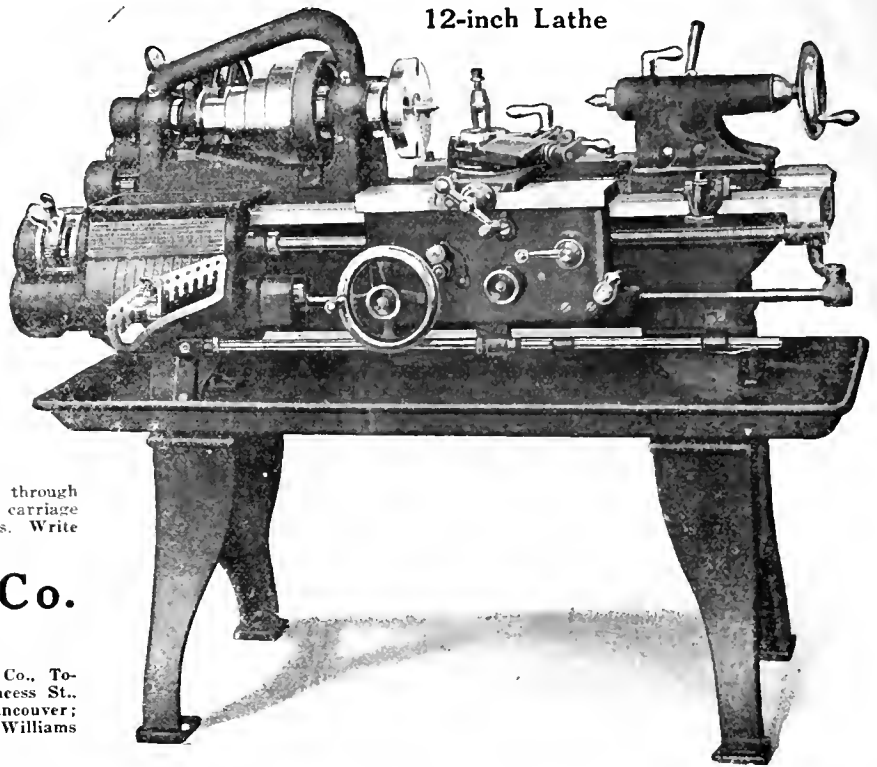

Mounted quick-change gearing was first made a commercial success on this type of Hendey Lathe. It got away to a good start and still maintains its initial advantages. Used more than any other quick-change lathe manufactured — its top-notch efficiency holds the field.

Thirty-six different threads and feeds are had through mounted change gearing. Automatic stop for carriage works in either direction. Has host of features. Write for full particulars.

Hendey Machine Co. Torrington, Conn., U.S.A.

Canadian Agents: A. R. Williams Machinery Co., Toronto; A. R. Williams Machinery Co., 260 Princess St., Winnipeg; A. R. Williams Machinery Co., Vancouver; A. R. Williams Machinery Co., St. John, N.B.; Williams & Wilson, Montreal.

INDEX TO ADVERTISERS

A	Acme Mach. Tool Co. 56	Adams, Ogden R. 70	Aikenhead Haws Co. 71	American Lead Pencil Co. 106	American Pulley Co. 106	Armstrong Bros. Tool Co. 148	Armstrong, Whitworth of Canada. 7	A.S.K. Chemical Co. 77	Atkins, Wm., & Co., Ltd. 15	Atlas Crucible Steel Co. 6	Atlas Press Co. 77	Aurora Tool Works 161												
B	Babeock & Sons 76	Baird Machine Co. 148	Bainfield, E. J. 18	Bainfield, W. H., & Sons 79	Barnes, W. F., & John 159	Barnes, Wallace, Co. 7	Bath & Co., Cyril J. 82	Beatty & Sons, M. 83	Beaudry & Co., Inc. 150	Bertram, John, & Sons Co., Ltd. 1	Bellevue Industrial Furnace Co. 96	Bilton Mach. Tool Co. 119	Blake Pump & Condenser Co. 31	Blackall, Fred S. 71	Brantford Oven & Rack Co. 24	Bridgford Mach. Tool Works 103	Bristol Company 147	Brown, Boggs 11	Brown Engineering Corp. 86	Brown & Sharpe 153	Brownell Machy. Co. 83	Brown's Copper & Brass Rolling Mills 5	Buden, Hanbury A. 76	Butterfield & Co., Inc. 145
C	Can. Bond Hanger & Coupling Co. 110	Canada Machinery Corporation Outside back cover	Canada Wire & Iron Goods Co. 107	Can. B. K. Morron Co. 4	Can. Fairbanks-Morse Co. 38	Can. Desmond-Stephan Mfg. Co. 159	Can. Drawn Steel 148	Can. Economic Lubricant Co. 197																
D	Can. Inspection & Testing Laboratories, Ltd. 147	Can. Hoskins, Ltd. 94, 96	Can. Steel Foundries, Ltd. 7	Can. S. K. F. Co. 35	Can. Welding Works 88	Carborundum Co. 134	Carlyle Johnson Mach. Co. 8	Carter Welding Co. 96	Chapman Double Ball Bearing Co. 149	Cincinnati Elec. Tool Co. 150	Cincinnati Iron & Steel Co. 29	Cincinnati Milling Mach. Co. 124	Cincinnati Pulley Machy. Co. 161	Clark Equipment Co. 157	Cleveland Milling Mach. Co. 26	Cleveland Twist Drill Co. 156	Commercial Acetylene Welding Co., Inc. 91	Constedt, Josef F. A. 89	Corbet Foundry & Mach. Co. 99	Cook, Asa S. 149	Cullen Machy. Co., F. W. 82	Curtis & Curtis Co. 129	Curtis Pneumatic Machy. Co. 112	Cushman Chuck Co. 149
E	Eastern Mach. Screw Corp. 144	Elmes, Chas. F. 115	Eric Foundry Co. 32																					
F	Fairley, Davison Steel Co., Inc. 9	Fetherstonhaugh & Co. 78	Fitchburg Grinding Mach. Co. 100	Fitzgerald, W. H. J. 82																				
G	Ford-Smith Mach. Co. 125	Foss & Hill Machy. Co. Inside back cover, 75	Fox Machine Co. 17	Francis & Co. 149																				
H	Galt Mach. Screw Co. 87	Garber Machine Co. 145	Garlock-Walker Machy. Co. 22	Garvin Mach. Co. 124	Geometric Tool Co. 69	Gibb Instrument Co. 98	Gilbert & Barker Co. 93	Globe Machine & Stamping Co. 114	Goddard Tool Co. 105	Goodell Pratt Co. 116	Goodyear Tire & Rubber Co., Ltd. 111	Gooley & Edlund, Inc. 127	Grant Mfg. & Machine Co. 32	Grant Gear Works, Inc. 156	Graton & Knight Mfg. Co. 113	Greenfield Machine Co. 136								
I	Ideal Tool & Mfg. Co. 144	Illinois Tool Works 75	Independent Pneumatic Tool Co. 133	Iron Works, The 76	International Mach. Tool Co. 88																			
J	Jacobs Mfg. Co. 165	Jardine Co., A. B. 159																						
K	Jacobs Mfg. Co. 99	Jersey City Mach. Co. 149	Jobborn, Geo. E. 74	Johnson Mach. Co., Carlyle 8	Joyce, Geo. A., Co. 149																			
L	Kempsmith Mfg. Co. 127	Kilston & Co., A. G. 29																						
M	L'Air Liquide Society 139	Landis Machine Co. 148	LeBlond Mach. Tool Co., R. K. 13	Latrobe Elec. Steel Co. 16																				
N	Macnab, John, Machy. Co. 122	Marion & Marion 76	Manufacturers Equipment Co. 141	Marsh & Henthorn, Ltd. 107	Matthews, Jas. H., & Co., Inc. 36	McCabe, J. J. 84	McCoy-Brandt Machy. Co. 82	McDougall Co., H. Inside back cover	McKinnon Dash Co. 81	McLaren, J. C., Belting Co. 147	Mechanical Engineering Co. 73	Mercury Mfg. Co. 99	Metalwood Mfg. Co. 115	Metals Coating Co. 18	Michigan Steel Exchange, Inc. 14	Millers Falls Co. 130	Miller, Smythe Elec. Co. 81	Miltholland Co., W. K. 123	Monarch Brass Mfg. Co. 86	Montreal Machy. & Supplies 156	Modern Tool Co. 140	Morton Mfg. Co. 77	Murchev Machine & Tool Co. 143	
O	Napier Saw Works, Inc. 131	National Acme Co. 142	National Electric Welder Co. 118	National Machine Tool Co. 149	New Britain Mach. Co. 27	New York Machinery Exchange 84																		

Concluded on Page 165



EXTERIOR OF BUILDING, SHOWING GLASS WALL CONSTRUCTION WHICH INSURES MAXIMUM LIGHT AND VENTILATION.

Production of Twist Drills in a Specialized Canadian Factory

Staff Article

Small tools and special items of machine shop equipment, have, in common with machine tools and larger equipment, experienced a period of great demand, although, perhaps due to their lesser intrinsic value, the demand for them has not attracted similar attention. The success attending the efforts of the pioneer twist drill factory in the Dominion is indicative of the results which await organized effort in many allied lines of accessory equipment.

DURING the last three years the demand for machine tools in Canada has been so great and has involved such continuous effort by all branches of the metal working industries that the persistent and consistent growth of accessory manufacturing plants has, to a considerable degree been overlooked.

While twist drills may be classed as an accessory, their functions are so vital to the successful performance of many machine shop operations, that they are well entitled to be classed as a necessity along with taps, reamers, and similar small tools. The industrial growth of the Dominion has been so great that the consumption of this class of product has for some time been large enough to warrant the establishment of a plant devoted entirely to the manufacture of twist drills and concrete evidence of this fact is offered by the Wilt Twist Drill Co. of Canada, Ltd., which since the latter part of 1913 has been engaged in production.

The concern was organized in that year by A. D. Wilt, Jr., of Dayton, Ohio, to whose business acumen must be credited the perception of the opportunity and the successful fulfilment of the company's prospects. Operations were commenced on a modest scale at Walkerville, Ont., and from the first facilities had to be rapidly increased to keep pace with the demand for drills until a point

was reached which necessitated the erection of an entirely new plant, which would have ample capacity for the now greatly increased demand and allow of suitable future extensions when required. To this end several acres of ground were acquired, situated on Walker Road, Walkerville, and a factory erected thereon during the summer of 1916, occupancy being obtained by the company in September of that year.

Factory Building

The building is of steel truss design and consists of two bays having a total width of 98 feet, with a length of 228 feet. It was specially designed for the owners by the Austin Co., of Cleveland and in design and construction it represents the most modern type of industrial construction. Particular attention was given to the provision of maximum light and ventilation, the nature of the work rendering the presence of the former a desideratum. As can be observed from the illustration of exterior, this has been accomplished by

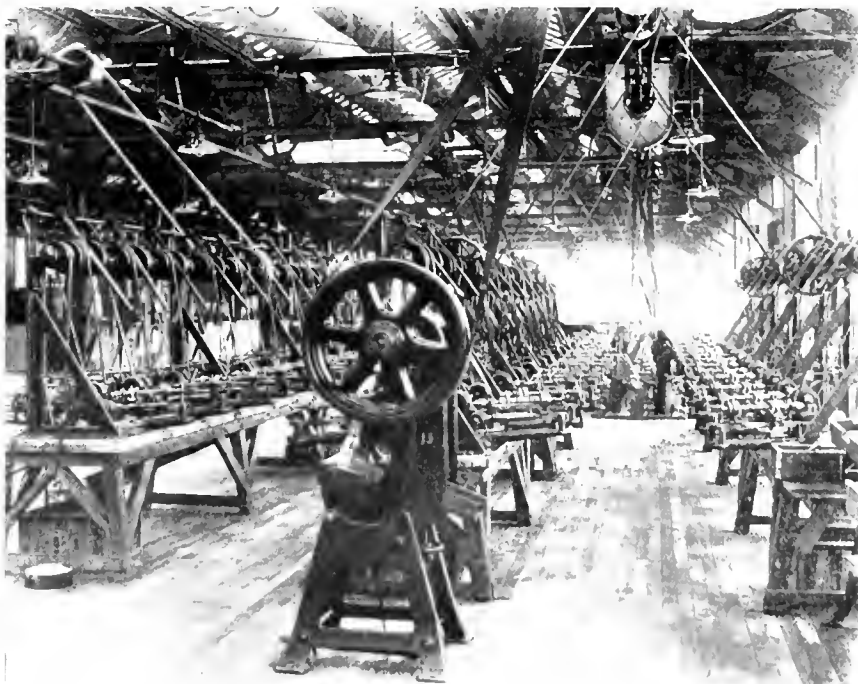

BATTERIES OF MILLING MACHINES WHICH FORM THE GROOVES IN TWIST DRILLS.

making each side of building a complete window in itself, combined with the provision of glass panels in the tile roof. The building is therefore entirely enclosed by glass, supported in steel sash of the Trussed Concrete Steel Company's type, there being small brick piers at each corner only. With a few exceptions, where tie-rods would interfere with operation, all the units comprising the openings are fitted with ventilators, and this, combined with the mechanical heating and ventilating system gives purity of air practically equal to outdoors. The roof is of Federal Cement tile, with large glazed areas.

The interior arrangement of the building will be gathered from the views thereof. The steel roof trusses are suitably spaced, and are of convenient section to facilitate the attachment of countershaft beams to their underside. All machines are group driven by overhead motors located near the main columns, of which there is a row down the centre of the shop between the two bays. This arrangement enables machines to be grouped in any desired manner in any part of the shop without any trouble in arranging countershaft drives.

The plan drawing of the factory shows the location of the various departments, the power house, sand blast and hardening rooms being located in a separate building connected to the main building by a covered fire-proof passageway. The power house contains a Goldie & McCulloch return tubular boiler for heating purposes, equipped with Tate-Jones natural gas burning apparatus. In connection with the heating system is a Sirocco blower installation, located in the valley of the roof above the central row of shop columns, from which central location the heated air is distributed through overhead pipes with downward exits.

Other power house equipment includes a 7½ x 6 in. belt driven air compressor by Chicago Pneumatic Tool Co., driven by a 15 horse-power Westinghouse motor, which supplies air for the Franklin sand blast equipment installed by the same firm. Blower requirements for the hardening room are met by a Connersville blower, belt driven from a 15 horse-power Westinghouse motor.

Twist Drill Features

The twist drill, as produced to-day is a precision tool of extreme accuracy and, when viewed in the light of what it can do when given proper treatment, and what it is expected to do with a deal of improper treatment, it is doubtful if any other minor item of machine shop equipment possesses a similar degree of efficiency. While increased costs of material have added to the expense of these, in line with every other product, the fact remains that in normal

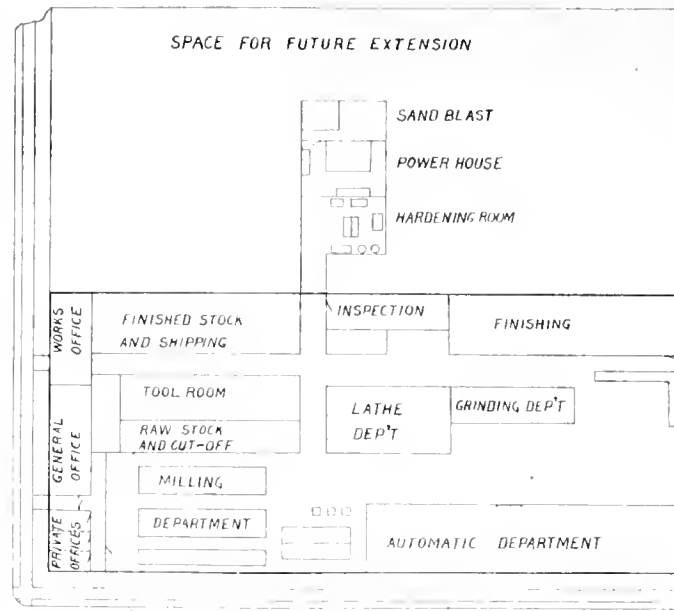

LAYOUT OF FACTORY SHOWING ARRANGEMENT OF DEPARTMENTS.

times, the modern twist drill is practically without an equal in percentage of service rendered for a given cost.

Both carbon and high speed steel drills are produced in all sizes and types regularly in demand by consumers. The facilities of the plant, and nature of the equipment, coupled with the extended experience of the staff, enable special drills of a wide variety of types to be produced when occasion requires.

The success attending the efforts of the company to produce a drill perfect in all respects has been largely due to the process developed by them in which the drill is machined complete from the rough stock at one setting instead of

undergoing six or seven different machining processes hitherto necessary. The development of special automatic machines for this work has been a feature of the firm's activity, and the success attendant on their operation has enabled them to be adapted to the majority of sizes in general demand.

The necessity for extreme activity even in the rough machining of twist drills will be understood from a study of the diagrams on page 446. Ample chip clearance and free cutting are obtained in Fig. 1 at a sacrifice of strength, so that the strain of operation soon causes collapse, an occurrence which is hastened by the lack of sufficient metal to carry away the heat generated by friction, which greatly reduces the ability of the cutting edge to stand up to the work. The opposite extreme is shown in Fig. 2, where the

grooves are so narrow that there is not room for chip clearance, resulting in excessive heat and power required to drive. Fig. 3 shows a perfectly balanced drill such as is produced by the Wilt process, which combines proper chip clearance with ample metal in the web to give strength and carry off heat.

The necessity for proper balance and the exact nature of this feature will be appreciated from a study of Fig. 4; while the condition is exaggerated, the effects are present in any drill which is not correctly machined. Trouble due to this error generally becomes evident in the hardening operation, due to the fact that more metal in one lip than the other causes an unequal strain when the drill is quenched. The quicker contraction of

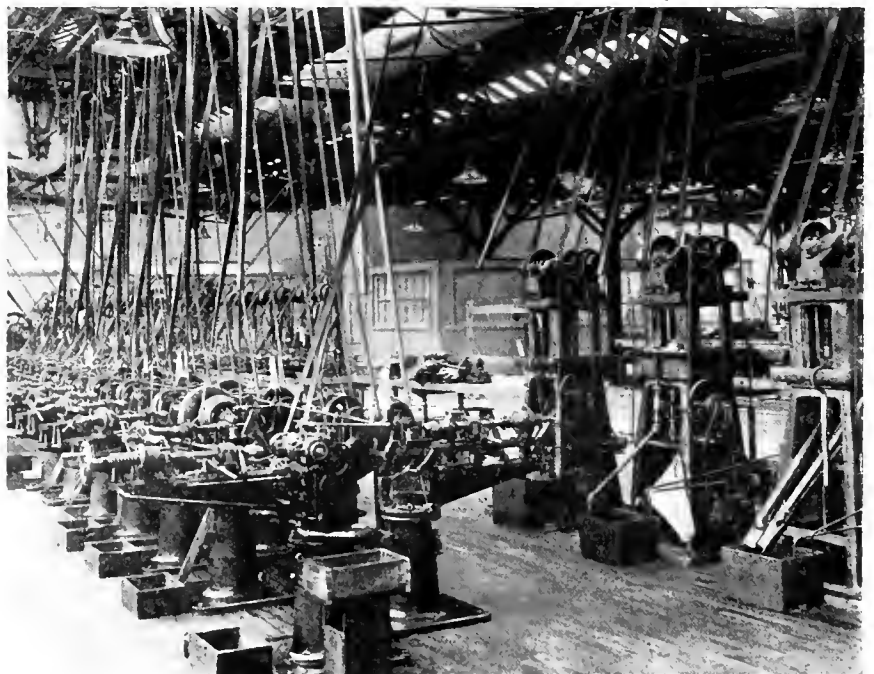

ANOTHER VIEW OF MILLING DEPARTMENT, SHOWING RELIEVING MACHINES AND SPECIAL VERTICAL MILLERS.

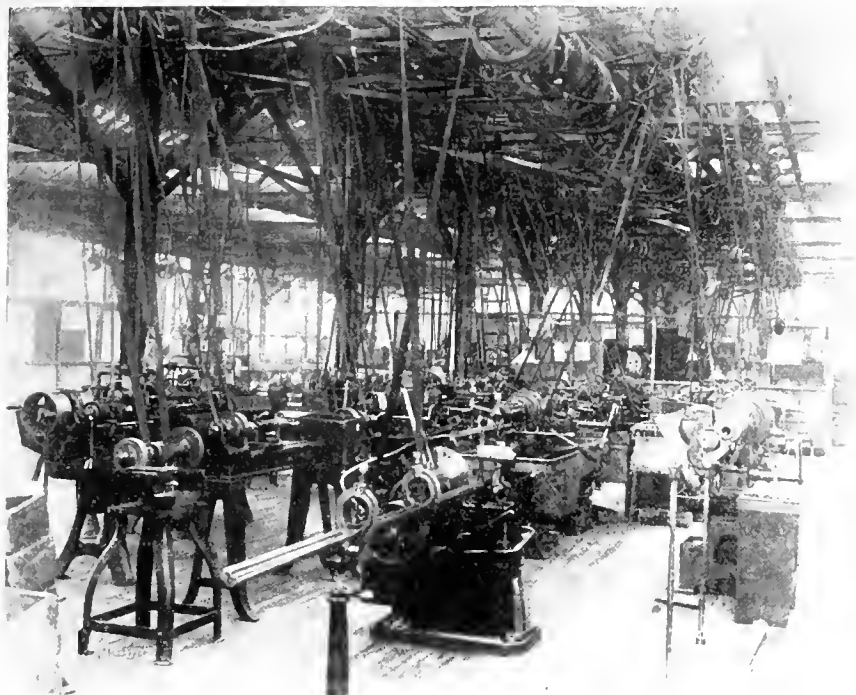

LATHE DEPARTMENT WHERE STOCK IS MACHINED PREPARATORY TO MILLING.

lip A sets up a strain along the centre of the drill C, which is then very liable to crack lengthwise along the web, this cracking frequently taking place before the drill is put into use. Should the drill happen to survive the strain of hardening, the lack of balance makes it impossible to grind it so that each lip will do an equal amount of work, resulting in an excessive strain on lip B, and a hole larger than the drill, and of very imperfect accuracy and finish.

The efforts of the Wilt Co. to develop drill-making machinery of the automatic type have been successful to such an extent that with the exception of small and wire size drills and special large sizes, they are now producing the greater range of sizes in this manner. The demand for small drills is such, however, that a goodly portion of their plant is employed in producing these with standard types of equipment, pending the development of automatic machinery embodying certain improvements and refinements. As the automatic machines combine all of the operations ordinarily performed separately, an outline of the regular routine of drill-making may not be without interest.

Raw Material

All drill material is supplied to specification, either in carbon or high speed steel, and in smooth drawn or hot rolled finish. The bars, rods, or wire, according to the size required, are stored in racks in the stock room, which is equipped with cutting-off machinery as all raw stock is cut to length and pointed before entering on drill making proper. Prominent amongst the machines here is a Cochrane-Bly cold saw equipped with triangular clamps for holding several bars of stock at one time. This machine handles all medium sizes, while a punch press with suitable gauging attachments

takes care of all wire size stock. Both ends of the piece are now pointed simultaneously in a special type of speed lathe equipped with a live tailstock spindle which revolves in the same direction as the headstock spindle. Each spindle is equipped with a single blade cutter on the same principle as a pencil sharpener, and while holding the work in pliers with one hand, the operator pulls the tailstock cutter against its end, which forces the other end into the other cutter.

The lathe department is devoted to cutting-off, pointing, body turning, and shank forming on medium and large size

drills. The cutting-off is done in powerful hollow spindle lathes after the bar has been pointed in the same machine, after which the shank end is centre drilled and notched with a square spindle when the body is being turned. During this operation the point of the drill blank is supported in a conical cup centre of slightly smaller diameter than the drill body. This method of support and driving is also adopted in lathes which are set up for machining the taper shanks; in this case taper attachments are used to give the correct outline.

Varied requirements in drill specifications necessitate a certain degree of adaptability in the equipment, hence we find special purpose lathes of peculiar design, engine lathes with wide range of capacity, single purpose turret lathes, and several hollow spindle automatic machines of the Cleveland type all occupied on what is more or less straight turning work.

Milling and Relieving

Drill blanks of the proper size are now conveyed to the milling machines, either in the automatic department, or in the small drill department, the latter of which is illustrated on page 443. Here the blanks have the grooves milled and the relief formed on the body. These machines consist of a work holding spindle provided with suitable lead screw for imparting the pitch, the spindle being set at the proper angle to the cutter. The work is supported in a bushing below the cutter, the bushing being cut away on the top side to allow the cutter access to the work and yet give all possible support. Automatic stops drop the work clear of the cutter when the end of the cut is reached, after which the work is drawn back, revolved one hundred and eighty degrees, and the second groove milled.

Relieving on the smaller drills is done

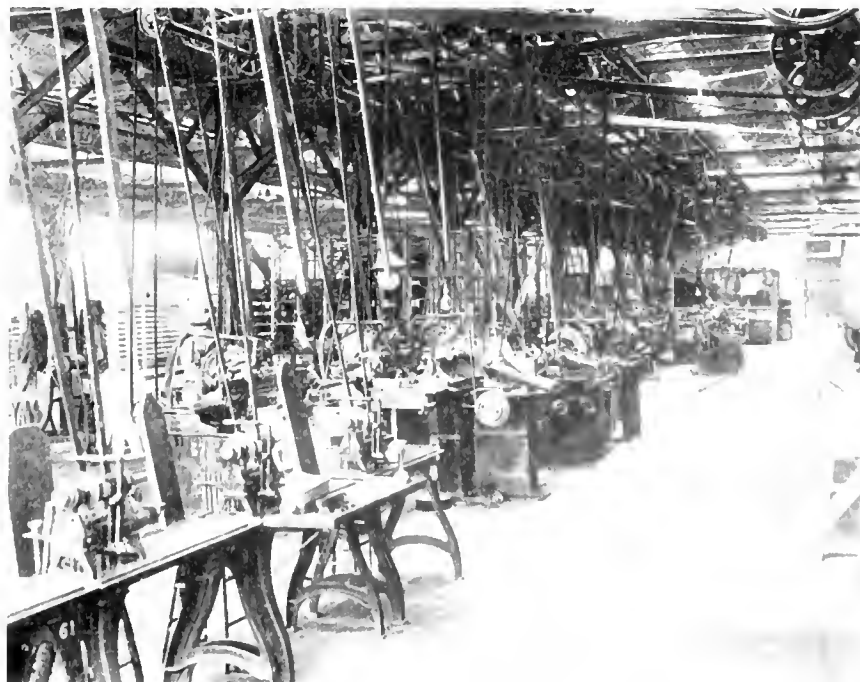

VIEW OF GRINDING DEPARTMENT WITH FINISHING MACHINES IN FOREGROUND

on a special machine with two end mills which relieve both sides simultaneously. Its general construction is similar to the groove millers, having a lead screw according to pitch, but with the work travelling square to the cutter spindles instead of obliquely in the groove milling. The relieving of wire drills is done by

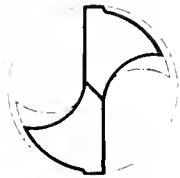

FIG. 1.

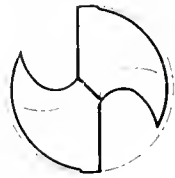

FIG. 2.

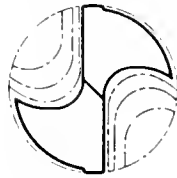

FIG. 3.

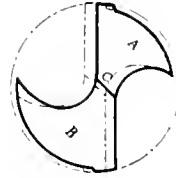

FIG. 4.

the aid of small grinding wheels in front of which a special bushing is arranged through which the drill passes; one groove engaging a projecting pin which causes the drill to revolve so that as it passes across the face of the wheel from left to right and back again, the proper amount of surface is ground off to form the relief. Before doing this it is necessary to remove all rags, etc., from the grooves and this is performed by hand with a round file; this work is done by girls who acquire a peculiar deftness and lightness of touch so that flattened edges and other results of careless workmanship are very rare.

Heat Treatment

The marking of the maker's name and drill size is done immediately after milling, so that the drill is now ready for hardening. Every possible precaution dictated by science and experience is taken to impart to the material that condition which is best suited for its work. Not only has the work to be done with an exactitude seldom met with in other lines, but quantity production is likewise a requisite of the equipment. Among interesting items of equipment is a Hoskins electric furnace of the carbon resistance type for obtaining the high temperatures required in hardening alloy steels, the non-oxidizing features of this furnace being a desirable feature when handling highly finished machine work. Gas furnaces, lead baths, oil tempering furnaces, and quenching baths and pyrometer equipment are all evidence of the care exercised in this operation.

Despite all efforts to the contrary, a slight amount of warp will occasionally develop in hardened drills, especially the smaller sizes. As a result of the special heat treatment, there remains ample toughness to allow of the warp being removed with care. Special benches with gas burners, surface plates, and small straightening presses enable this work to be performed with great accuracy and speed, following which the sand blast removes any marks from heating and imparts the fresh clean appearance so typical of new drills.

Finish Grinding

Standard types of grinding machines are employed on the finishing of bodies and shanks. This work calls for a high degree of accuracy and fineness of fin-

ish which demand high grade equipment and skilled labor. The drill is driven by a special driver which engages the grooves, and centres the work by the point which has acted as positioning base throughout, the shank end being supported on a centre if tapered, or on a conical cup centre if parallel. On the

completion of grinding, a working edge is put on the point of the drill, after which it is ready for shipment.

The upkeep of machinery such as is shown in the various illustrations calls for an efficient tool room installation. The principle requirement, of course, is milling cutters, large numbers of these being used in the course of operations. The cutter blanks are cut off from bars of suitable size in a hacksaw with multiple blades, and are then drilled, machined to size, gashed for teeth and backed off. After hardening, grinding, and sharpening cutters are kept ready for use in the tool crib, their maintenance in good condition being facilitated by the installation of a LeBlond cutter grinder.

Milling machines form a considerable portion of the tool room equipment, including such makes as "Cincinnati," "Milwaukee," and "Le Blond," while, in addition to a full complement of tool-room lathes, there is a special cutter relieving machine of recent type built by the Cleveland Milling Machine Co. Shapers, key-way cutters, drills, etc., balance out the equipment in suitable manner.

BALL BEARINGS

UNDER the auspices of the Society of Engineers (Incorp.) a paper on Ball

Bearings was read on April 2 by A. Marshall Arter, F. S. E. A brief resume was given of Prof. Stribeck's investigations.

Before these investigations were made little was known beyond Henry Hertz's theoretical deductions on the contact of elastic bodies. Prof. Stribeck measured the approach of hardened steel balls under compression and found that the admissible static loads varied as the square of the diameter; he also found that ball bearings in which the load is carried at right angles to the axis of rotation of the balls were alone suitable for heavy loads. It was pointed out that the balls in modern ball bearings did not burst, but that the surface flaked out when overloaded, the load-carrying capacity depending upon the elastic limit of the surface of the steel.

The author further pointed out that the ball bearing of to-day could never have been made a commercial success but for the very high degree of accuracy in its manufacture. If a load of 130 lbs. is put upon a ball half an inch in diameter, it is compressed one-thousandth of an inch, and hence if one of the balls in a thrust bearing is one thousandth of an inch larger than the rest, or there is a high place in the race of this amount failure is certain if the normal load of the ball is at all approaching the safe working limit.

The relation of load to speed was dealt with, and it was shown that the safe working load of a ball was reduced on increasing its speed of rotation, in thrust bearings the amount being greater than in radial ones. Prof. Goodman's method of examining balls under a microscope for detecting overloading was explained.

The gyroscopic effects, at high speeds, in thrust bearings was next dealt with. It was shown that there is a certain minimum load necessary to prevent the balls skidding, due to gyroscopic torque, and that there is an absolute limit of speed at which a thrust bearing can be run, namely, when the maximum and minimum loads coincide.

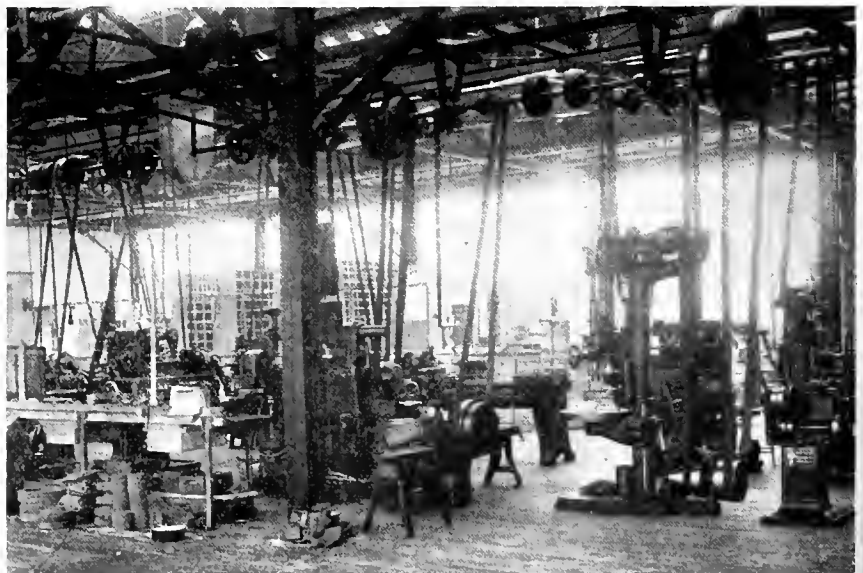

VIEW OF TOOL ROOM WITH FINISHED STOCK ROOM IN BACKGROUND

PRODUCTION METHODS AND DEVICES

A Department for the Interchange and Distribution of Shop and Office Data and Ideas Evolved from Actual Practical Application and Experience

CENTERING SHELLS

By R. Hamilton.

MACHINING from rough forgings necessitates careful calculations in the preparation of the material for the preliminary operations so that sufficient stock be left on all portions for the finishing of the product. In the case of shells of various types, where the eccentricity of the bore and the outer surface is often a serious question, it is a difficult problem to determine just where to place the centre in the base end so that the machining of the different parts of the shell will conform to the desired specifications. Due to the defects in the forging process, shells are often delivered to the machining plants that require careful judgment on the part of the manufacturer in deciding whether any particular shell can be machined without developing additional defects. Owing to the large quantity of shells produced, it has been almost impossible to avoid many of them being forged with eccentric walls, and to prevent the enormous loss that would be entailed by the rejection of all, manufacturers have endeavored to adjust these defects, and have been successful to the extent that large numbers have been saved that otherwise would have revert-

been the practice to locate this centre by placing a shell on a suitable post or expanding arbor, either on a drill press or a lathe, so that the centre of the rough bore would coincide with the axis of the drill or lathe spindle.

It subsequently developed however, that many shells were being thrown out because the outside would not clean up, owing to the excessive eccentricity, and in order to save the greater number of these shells it was necessary to draw the base centre over sufficiently to provide stock enough on the low side to finish to the specified dimensions. This process was originally performed by a hand operation; that is, by drawing the centre over with a centre punch and drilling separately. Arising out of this procedure, jigs were developed that would indicate the error at the time it was placed on the centering fixture and, without removing the shell, the jig could be adjusted to permit of the centre hole being placed eccentric with the bore, and thus strike a fair average for the machining of either surface. The device illustrated in Fig. 1 shows the arrangement of a centering attachment that permits of reasonable adjustment to permit of alignment before centering the base. The base of the fixture, which is secured to the drill press footplate, carries the

rocking piece A pivoted on the bolt B. This tilting piece is provided with a lug C that comes in contact with the base, and keeps the shell in a vertical position. The lower portion D of the supporting post is turned eccentric to the upper section of the shell post, the downward thrust being taken by the flange F. The amount of this eccentricity is indicated in the right hand view, and gives a variation of about $\frac{3}{32}$ of an inch. A steel ring is placed on the top of this post to fit the inside profile of the rough forging. Fitted to the housing of the drill

position as shown by the dotted lines, the tilting piece locked by the dog coming in contact with the stop N, this being released by the lever N; the roller table P supplies a convenient means of handling the shells to and from the machine. After the fixture has been raised to the vertical position, the stop C comes in contact with the base and is retained there owing to the weight being located between it and the fulcrum B. The gauge I is then pulled down by hand and, if the shell protrudes on all sides, the hole is drilled; but if the eccentricity is great and the gauge extends over, the post is revolved by the handle O until the shell shows on all sides.

The object aimed at in the development of the device shown in Fig. 2 was to incorporate effective gauging facilities with the actual operation of centering the base. This fixture was designed so that the shell could be inspected for eccentricity and base thickness as soon as it was placed on the jig, and before the base was centered, in order to discover whether the shells would clean up both on the inside and the outside; in fact, it is intended to eliminate the human equation and make the attachment practically foolproof, not relying on the judgment of the inspector as to how far a centre should be drawn. It should be understood that the principle involved in this fixture may be differentiated to suit the ideas and tools used by the various manufacturers, and its component parts can be changed in proportional dimensions to suit the size of the different

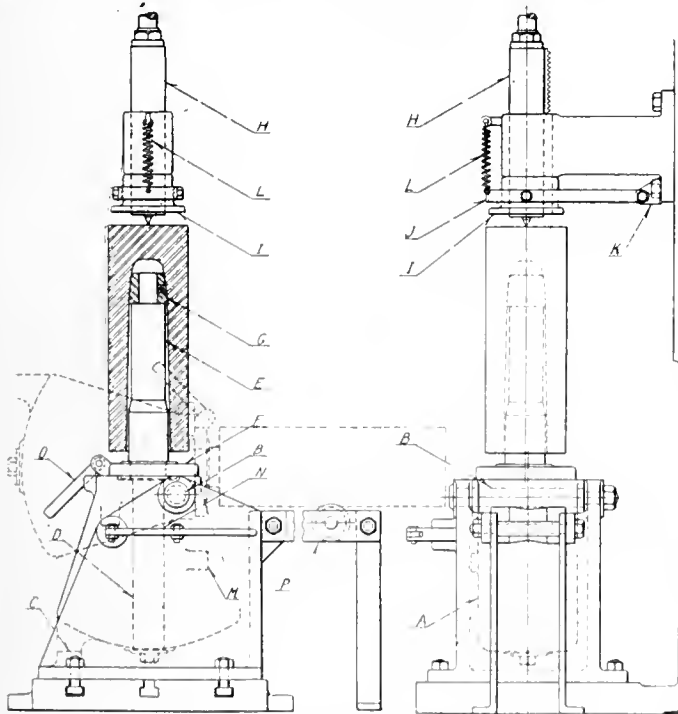

FIG. 1. CENTERING SHELLS.

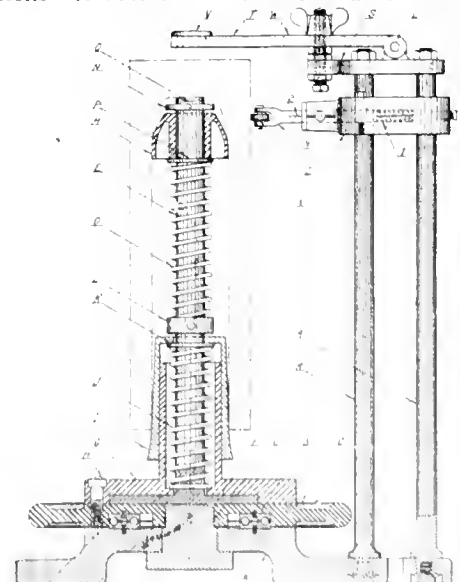

FIG. 2. CENTERING SHELLS.

ed to the scrap heap. On account of the difficulties incidental to the boring operations, it has been found advisable to commence the machining of the shells by using the bore as a base. Therefore, when centering the base end preparatory to rough turning the outer diameter, it has

spindle H, but with a free vertical movement, is the ring gauge I, held in position by the yolk J, which is pivoted at the back end in the bracket K and supported at the outer end by the spring L. When a shell is placed on the fixture, the mandrel is in a horizontal

shells now being made. The fixture is intended to be fastened to the table of a large single spindle drill in such a manner as to be able to swing the fixture out from under the spindle and back again to a stop fixed on the drill table. Fitted to the base A is the double ball

bearing B, upon which the upper portion of the fixture is revolved, the top raceway being secured to the hand wheel C, this being retained in a free working position by the retaining block D. The shell stanchion or post E has a wide flange, eccentric with the shaft, that rests upon the hand wheel C, and is held in position by the piece G, this in turn being locked to the wheel by the screw H. Surrounding the shell portion of the piece G is the tapered bush I, which centralizes the open end of the forging. It will be noticed that space is provided around the post to permit of movement when the shell is being moved to position. To prevent the spring J from interfering with the lateral movement of the stanchion, the plate K is placed about the post to take the thrust of the spring. The collar L serves two purposes, that of controlling the movement of the bush I and to form a seat for the upper spring; this provision being necessary for the independent control of the separate gauging pieces. The top block M is fitted to the shaft in the same manner as the lower one, the washer N determining the upward movement of the piece. The top of the shaft is shaped so that the inner base of the rough forging rests upon four points, as shown at Q. To carry the concentricity gauging apparatus and also the drill jig bracket, the three pillar bolts RR¹ are firmly secured in the base of the fixture. On the upper end of these three bolts the plate bracket S is located, the swinging arm T being pivoted at U, and its outer end carrying the drill bush V. The arm T is provided with a slot W that allows it to be swung clear when the wing nut is released. At a suitable distance down the pillars the collar X is secured; this collar carries the indicator arm Y with a wheel supported in the outer fork. The spring 1 keeps the arm out to its extreme forward position when the shell is in place.

The operation of the fixture may be described as follows:—The scale should be first removed from the inner base of the forging to insure proper contact and avoid false indicating. With the shell in position on the stanchion the jig top T is dropped into position and fastened. A limit gauge, made in any form, is then placed between the top of the shell forging and the bottom of the jig arm, to determine whether there is sufficient metal at the base for finishing. If not, the shell is immediately rejected. If base is of the desired thickness, the indicating arm is released, the tension of the spring 1 forcing it out as far as it will go, thus bringing the wheel Z in contact with the outside of the forging. The fixture, and the shell are then revolved by turning the hand wheel C; if daylight appears between the forging and the indicating wheel, the hand wheel is held stationary and the stanchion revolved through an angle approximating 20 degrees. This action is accomplished by a lever extending out from the flange F and through a slot in the ring G. When the lever is at the rear of the slot, the post is in a central position, and when at the forward end, the bore

has been moved from a central position in amount that will still permit of the interior cleaning up to the finished dimensions. The eccentricity is again tested by turning the shell by the hand wheel to determine whether the forging will still clean up. This manner of inspection has involved a certain amount of error being distributed to the bore, but the amount of error so distributed is usually not great enough to prevent the shell cleaning up in the bore, while it also shows whether the shell will clean up on the outside, and this is accomplished with the minimum expenditure of labor. The fixture is then swung under the drill spindle and the center hole drilled.

The slot in the indicating arm should be so placed that when the arm is in the extreme forward position, the outer edge of the wheel Z will be at a distance from the centre of the stanchion equal to one half the diameter of the finished shell, plus the amount of stock that is necessary to finish the outside.

RECLAIMING NUTS

By E. T. S.

THE amount of reclaiming that can be done in the matter of nuts, largely depends on the facilities of the plant in the way of machinery to assist in the production of the serviceable materials. The point having come to our notice that large quantities of nuts were available incidentally, the machine must be made to run backwards. For the large nuts we decided that a couple of old lathes could be fitted up so as to handle the large and medium sized nuts, utilising the tailstock of each lathe to remove

a forged steel block that had a taper square hole cut in the center. Of course the smaller sizes go into the chuck a little further than the large ones but that does not affect anything. Hexagon and square nuts all fit into the same chuck, the bolt with the nut projecting forward being traversed into the chuck until the nut is held and turned off. For the large nuts, the regular tool carriage for service if they could only be gotten off the bolts upon which they were either too tight or rusted, led us to believe in and to consider mechanical means of reclaiming same. The first subdivision of whole nuts that would not come off was into three parts, large nuts, those over 1 in. in diameter; medium sized nuts, those between 1 in. in diameter and $\frac{3}{8}$ in., and small nuts those under $\frac{5}{8}$ in. in diameter.

It was obvious that whatever machinery was used it must consist of a gripping device to hold the short end of the bolt, and when a chuck must be made that would take in all sizes of nuts and, was used, the gripping dogs being the grip gear complete from an old Acme bolt threader that had been scrapped.

For the medium sized nuts the tailstock was fitted with a shaft with a similar chuck to the one at the large end, and a belt pulley on the other. For a carriage we cast a large block and bolted a rack, in between the lathe guides, on the bottom of the block. A hole was then bored in the side of the lathe bed for an operating spindle upon which a pinion was placed to mesh in the rack. Another set of threading machine dogs were set on top of the block so that the whole machine was practically reclaimed

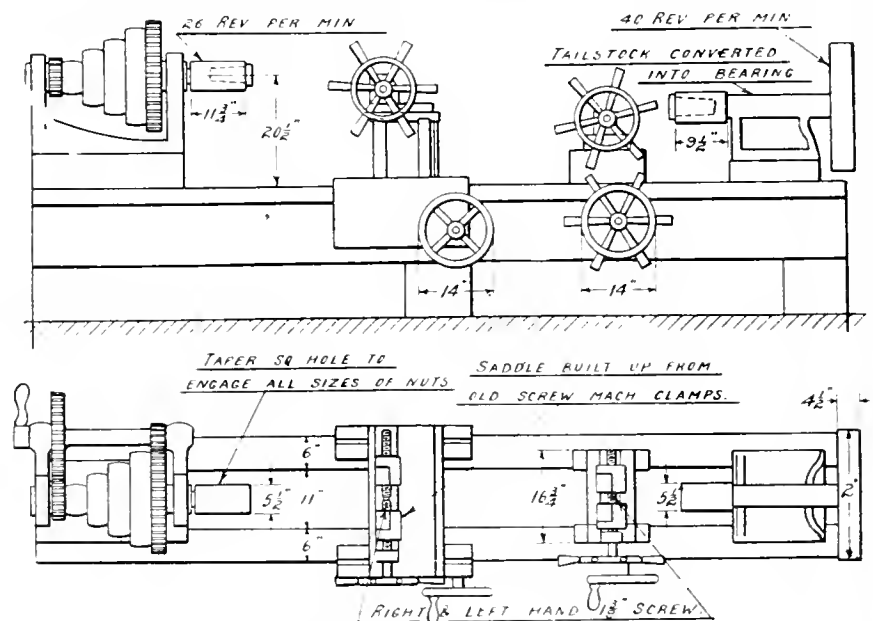

FIG. 1. EQUIPMENT FOR RECLAIMING LARGE NUTS.

the medium sizes on account of that being the weaker end, and the headstocks of each lathe for the large nuts, because it was already fitted with a back gear and ready to run at a suitable speed.

Fig. 1 shows how this has been accomplished. For a chuck to remove the nuts we fitted to the mandril of the lathe

from scrap. For the large sized nuts, a speed of 28 revolutions per minute was found sufficient, and for the medium sizes it was raised to 40 revs. per min. We have had two of these machines working for the past year now with exceedingly good results.

For the smaller nuts we found that a lighter mechanism would be more handy,

and so decided to use an obsolete drilling machine for the purpose. This was set up and extra keys put in where needed to prevent it loosening up on account of it running backwards. The hand-operated gripping dogs did not operate quick enough on this machine so the

to minimize the faults in this connection.

One of the essentials in the satisfactory operation of forming cutters is the accuracy with which they are ground and the devices by which this feature is attained. To eliminate the possibility of error on the part of the machine operator and at the same time ensure a uniform product, attachments have been designed and constructed whereby the cutters can be ground to the closest limits called for in the specifications. Many of these are of a very simple character and demonstrate the remarkable resources that have been uncovered by these past two years of necessity.

The accompanying cuts illustrate two methods by which the grinding of these profile cutters is achieved. Fig. 1 shows the design of an attachment, approved by the Imperial Munitions Board, for the grinding of the base cutters used in finishing the powder cup

line, the fixture being then locked by means of a dowel pin. For the short parallel section F, the fixture is maintained in the position shown, with the dowel in the hole G. The corner radius is derived by swinging the plate and the cutter through an angle of 90 degrees, the radius being determined by the position of the pivot pin H, this being the stud upon which the plate B is connected to the I beam A. To grind the front face I, the plate is swung to the position indicated by the dotted lines, with the finished edge D resting against the gauge piece J, this piece being adjustable and capable of being fixed in a permanent position. When performing the different grinding operations here shown, it should be borne in mind that the opposite side must be worked on alternately in order to maintain a uniform shape. The fixture is operated laterally by means of a suitable slide running parallel to the grinder shaft.

The other device, shown in Fig. 2, was designed for finishing the base profile cutters for the 4.5 inch shells. This attachment was developed by the Jenkes Machine Co. and has been of inestimable value in maintaining the efficiency of these cutters. The base A of cast iron is shaped so that the upper surface upon which the cutter is placed is at an angle with the base in all directions; thus bringing the cutter to the face of the grinding wheel at the desired angle for the proper clearance for every section of the cutter. The gauge C which determines the position for the base of the cutter is secured in a slot so that the gauging face is always at right angle to the axis of the cutter. The wing bolt serves as a locking device when desired position is obtained, the clamp E being used to hold the cutter firmly on the block. Accurate setting of the work is obtained by the screw F.

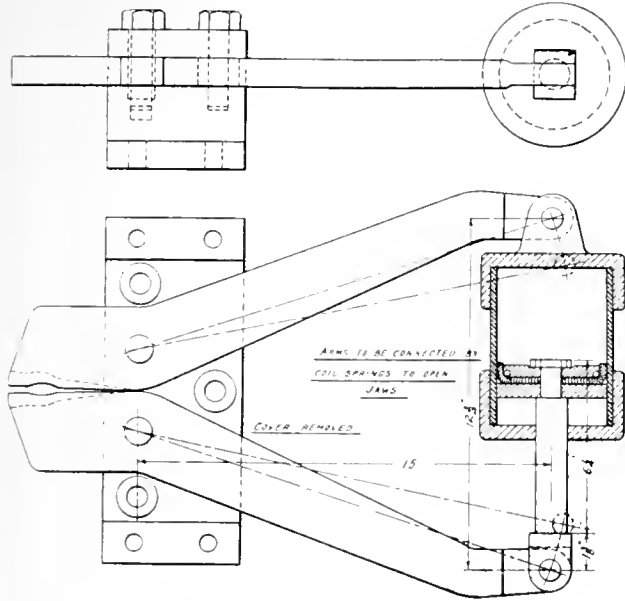

FIG. 2. GRIPPING CLAMP FOR RECLAIMING SMALL NUTS.

pneumatic vise or clamp, Fig. 2, was devised and found to be a great improvement. The operator simply turns a valve and the bolt is securely held. He then pulls down the spindle by means of the lever, the spindle having a nut chuck attached, just as if drilling a hole, and the nut is backed off. When the spindle is raised, the nut drops out, and, when the dogs are released, the bolt drops into a box. After removing nuts from the bolts, we pass them through a tapping machine, so as to be quite sure of the size, also to clean and lubricate same fit for service.

At different times I have heard it said that it does not pay to reclaim nuts. This is entirely wrong for I know that if the question is studied out there is more money in the number of nuts reclaimable than any engineer would admit he was losing by not reclaiming same.

GRINDING PROFILE CUTTERS

By J. H. R.

OWING to the distance that the inner base of the shells is from the open end, it is quite obvious that accurate gauging at this point is largely a matter of guess work; as a matter of fact, much reliance is placed upon the shape of the forming tools that machine this section of the shell, for bringing the base contour to the required shape and dimensions. It is therefore clear that special attention should be given to the problem of construction and subsequent maintenance of these profile cutters. As many of the shell rejections have been directly caused from defects at this particular part of the shell, manufacturers have devised various methods in order

to finish the powder cup chamber on the 18-pdr. British shrapnel shell. Mounted on a suitable framework is an adjustable cross slide upon which is secured a portable electric grinder. Parallel to the axis of this grinder an I beam A is located, the upper surface of which is provided with a plate that supports the cutter at the desired height to give the proper clearance to the cutting edge. This plate B is provided with two fixed dowel pins CC, upon which the cutter is located. When grinding the straight

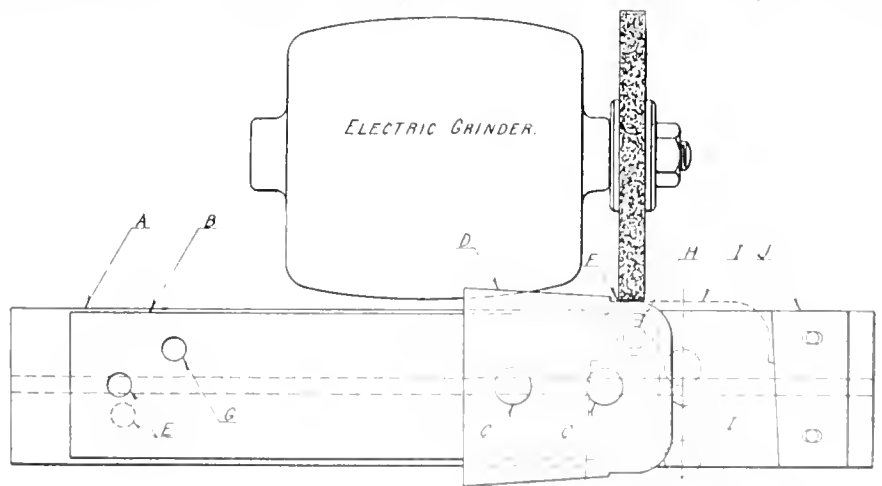

FIG. 1. GRINDING PROFILE CUTTERS

portion D which forms the section just above the powder chamber, the plate is moved from its shown position to the desired angle to bring the holes E in

The face of the head of this screw is divided into 50 equal divisions and with a thread of 20-pitch, an adjustment of 1-1000 of an inch is possible; the screw

can be permanently locked in any position by the clamping screw H. The operation of the device is as follows. The cutter is placed on the jig with the gauge C so located as to permit of grinding the face. Before placing the cutter on the jig and clamping in position, the size across the large end should be carefully measured by micrometer

ordinary milling machine vise, mounted on the table B of a hand miller. The jaws were made, as shown by C, so as not to distort the stock. The regular screw was removed, and in its place was screwed the stud D, which was a sliding fit through K, and was connected to a lever E, which pivoted around the stud F. At G is a heavy coil spring, which is

on work as illustrated may be judged from the fact that a good man could cut off over a thousand pieces per hour. To be exact, thirteen thousand per day was the average. The same idea can be applied to an infinite variety of work, not necessarily that of cutting up bar stock.

EMBARGO ON STEEL TURNINGS EXPORT

THE Canadian Government placed without warning, effective Saturday afternoon, April 21, an embargo against the shipment of steel shell turnings into the United States. Very considerable amounts had been purchased by consumers in the States, and large tonnages are still due on contracts which cannot now be filled. This scrap is very desirable on account of the analysis and is used in open-hearth practice. For some time an embargo had been in effect against the exportation to the United States, of heavy shell crop ends. The mills of the latter which are shipping billets into Canada for the manufacture of shells and which are large consumers of steel turnings will no doubt insist that the clause in their contracts which provides for the return of the scrap crop ends and turnings to them be complied with.

Production of shell turnings in Canada, it is believed, far exceeds Canadian consumption, and it is known that electric furnaces are being provided at Toronto under Canadian Government auspices, for the conversion of turnings into steel. A similar embargo placed about six months ago was shortly afterwards lifted by reason of the inability of the Canadian consumers to take care of their production. The embargo at that time immediately brought the price of turnings down \$5 or \$6 per ton below what could be obtained on this side. Much adverse criticism is heard on the action in placing this latest embargo, as consumers in Canada have the same opportunity to buy the scrap as American consumers and have generally been given preference at equal figures.

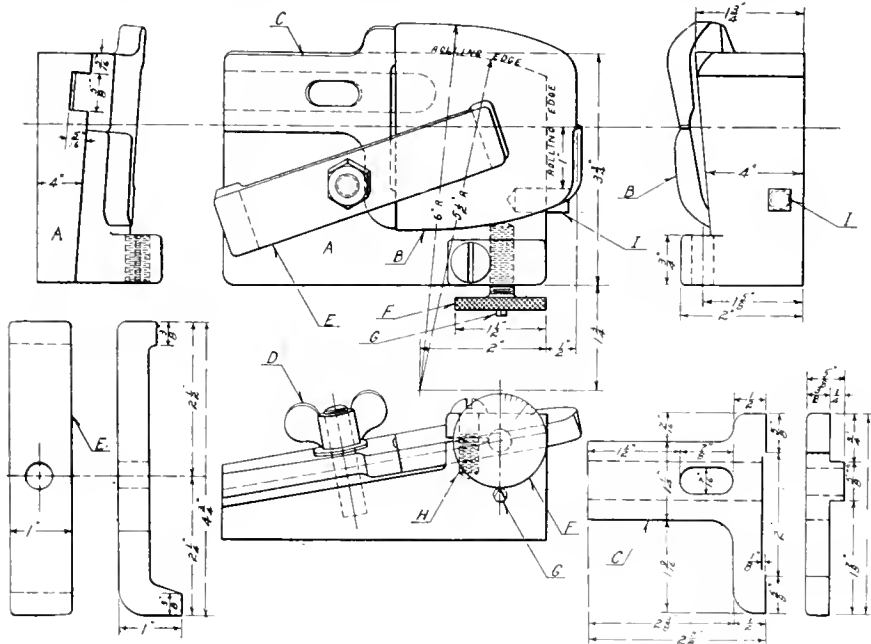
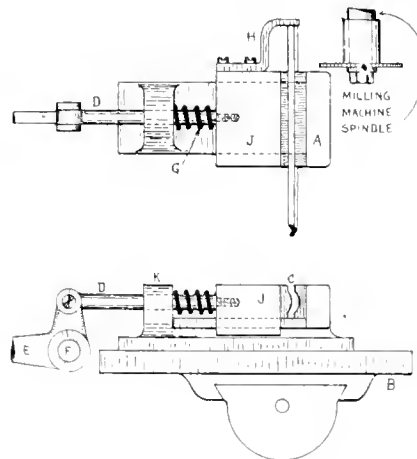

FIG. 2. GRINDING PROFILE CUTTERS.

and the dimension noted. With the cutter in position and the screw F well back, move the jig towards the grinding wheel until the rolling edges on the jig and table are in contact and then adjust the screw F until the wheel begins to cut. By subtracting the required dimension from that of the unground cutter, the amount of stock to be removed is readily obtained; then the screw F is adjusted by means of the graduations and the indicating point G so that half of this stock is removed from each side. It is desirable however, that if much is to be removed, it should not be done at the one setting but should be first roughed off and finished afterwards by reversing the cutter a couple of times. From the location of the rolling edges and the stop pin I, it is possible to always maintain the tit on the face in a central position. The rolling edge of the table is not shown, but this is a machined ridge on the table surface and located parallel to the axis of the grinding wheel and forward of the wheel sufficient for satisfactory operation.

sufficiently powerful to close the jaws of the vise and hold the work securely.

In operation, the lever E is first depressed, thus bringing the milling machine table back as far as the stops will allow it to go. When it has reached this position which can be controlled by the stops on the machine, the continued movement of the lever, acting on the stud D, draws the vise jaw J back and allows the strip of stock to be passed through, and up against the stop H,



CUTTING OFF STOCK IN THE MILLER.

which regulates the length of the piece to be cut. Then by operating the hand lever in the opposite direction the spring G closes the vise jaws on the work, and the lever carries the vise and miller table towards the saw where the piece is sawed off. The efficiency of this fixture

DOMINION BRIDGE GET STRUCTURAL STEEL CONTRACT

THE Department of Railways and Canals of the Canadian Government has placed a contract with the Dominion Bridge Co. of Montreal for 2,500 tons of structural steel for two piers and pier heds to be constructed in the harbor of Halifax, N.S. The steel will be furnished by the Bethlehem Steel Co. Bids have also been asked on 3,000 tons of structural steel for pier sheds at Quebec, but no award has meantime been announced.

Recent bids on the construction of the second unit of the Eaton department store at Toronto, requiring 12,000 tons of steel, were so high that it was decided to postpone the placing of the contract at this time. It will be recalled that the contract for the first unit was placed in February with the Dominion Bridge Co., and that the steel was ordered from the Bethlehem Steel Co. at \$100 per ton f.o.b., Toronto.

CUTTING OFF STOCK IN THE MILLER

By D. A. Baker.

THE fixture shown herewith should be of general interest on account of its adaptability to other work of a similar nature. In this case it was used for cutting off short lengths from strip brass, which had previously been rolled to a semi-circular form.

Referring to the drawing A is an or-

Tool Holder and Cutting Tool Application Data-III.

By F. Scriber

The approaching return to broader and more general lines of manufacture render a study of tool-holders very timely. While the welded tip has found considerable application under recent conditions of heavy duty and unskilled operation, the obvious advantages of well designed tool-holders are such as to insure a continuance of their use, more especially where variety of work offers increased efficiency opportunities for well assorted equipment.

IN the application of cutting tool holders, the design of the holder depends largely upon the cutter used. In most of the holders previously described, the blades were of such a shape that they could readily be handled for grinding. In the design of the first two holders shown by Fig. 15 which are for cutting forms, the width of the cut being taken makes it impossible to retain this grinding feature to good advantage. The upper view shows a convex cutter A which is made circular in form and beveled for cutting clearance. The cutter itself is held to the holder B by means of the

this illustration the cutter is seen clamped by the nut and bolt H. It can of course be ground repeatedly in the usual manner as provided for in disc cutters.

Having previously mentioned that this article would show a number of screw cutting tools, Fig. 16 shows three types used. The holders show a fixed clearance angle for the cutter X this being the most economical method of making a threading cutter as the latter is then ground on the top face, and consequently the angle of the tool is not changed. Where the blades are held so that the grinding must be done on the angular sides they are very easily ground out of shape. Referring to the constructional features in the upper view of Fig. 16, the threader cutter is clamped in the same manner as the disc cutter described in the last illustration, but, in addition, this holder carries a screw A, which provides for fine adjustments of the cutter being made. As anyone familiar with threading knows, the threading tool must be set or ground at an angle to conform with the angle of the spiral being cut, otherwise the tool will drag on the thread, and in like manner a threading cutter holder must be made to carry the blade at this angle, although in some cases the ends of the holders are made to swivel so that they can be clamped at various angles, thereby being suitable for quite a number of pitches, either right or left-hand.

In the second illustration, Fig. 16, is shown a threading cutter dovetailed into a holder at B. The blade in this instance is gripped by the wedging action of the clamp C against the back angle of the cutter, while the nut D tightens the clamp C by means of the stud E. Referring to the lower view in Fig. 16, this holder carries a cutter F, which is clamped by means of a strap G. The holder is designed to carry a cutter on either side, as will be evident from the tongue shapes on both sides of the end. This permits of having both ends of the tool ground, when, by reversing the blade and the strap, either end of the cutter may be used.

Mention has been made of the practice of grinding or setting the cutters on an angle to conform with angle of the thread being cut. Fig. 17 illustrates a type of thread cutter holder with a swivel head for this purpose. The shank of the holder A is, of course, held in the tool post in the usual manner, and the head B is clamped to the shank by means of the two screws C. This head contains the thread cutter D, which can be made square or round as required, the particular type shown being round. The cutter is clamped in place by the screw E, besides, another long screw and nut F

also help to clamp the swivel head to the holder, while the head swivels on seat X. It will be noticed in the end view that the slots through which the screws C pass are elongated in the swivel head. In operation the head is swiveled to the desired angle, and is then clamped securely; following this the threading is done in the usual manner. The outside angle of these heads is sometimes graduated where noted for convenience in setting the tool.

Referring to the second illustration in Fig. 17, this shows a disc threading cutter G, the cutter being held to the hold-

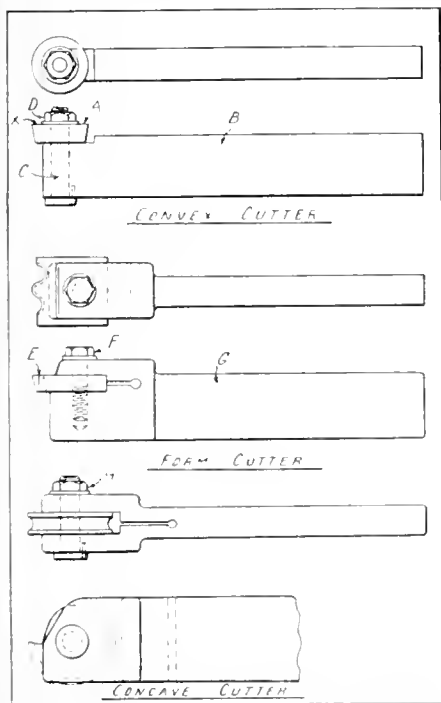

FIG. 15. GROUP OF CUTTERS AND HOLDERS USED FOR FORMING OPERATIONS.

bolt C which is in turn clamped by the nut D. Such a cutter would, of course, machine a concave groove, but is not very economical, as it must be ground on the upper face X. Grinding this face changes the radius of the cutter on account of the bevel, therefore but few grindings can be had, and in consequence it is not a good manufacturing tool.

In the middle view Fig. 15, a formed cutter E is shown. It is clamped by a screw F, while the holder G has a slot cut in it to receive the cutter, and also another slot to make a spring cutter binding holder of it. This cutter can be ground on the top face and an indefinite number of grinding can be had without changing its shape. The lower view Fig. 15 shows a circular concave cutter held in a spring clamping holder. In

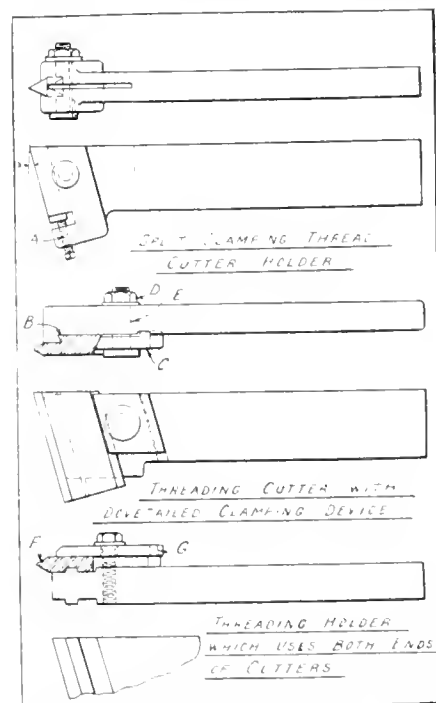

FIG. 16. GROUP OF CUTTERS AND HOLDERS USED FOR THREADING.

er by means of a draw bolt H. This cutter has a tapered portion, which fits in to the holder, thus giving it additional support. The bolt is also tapered at the cutter end and, when this bolt is tightened, the cutter is securely held. It will be noticed that there are no protruding portions at the cutter side of this holder, and, therefore, threading close to a shoulder is easily accomplished. In cutting a thread, it is very apparent that the threading tool will take quite a broad chip, this, of course, depending on the depth of the thread being cut, and as all broad cutting tools have a tendency to hog-in, it has been found advisable in many cases to make the threading tools slightly flexible. These tools are known as spring threading tools, and they are often called goose neck threading tools.

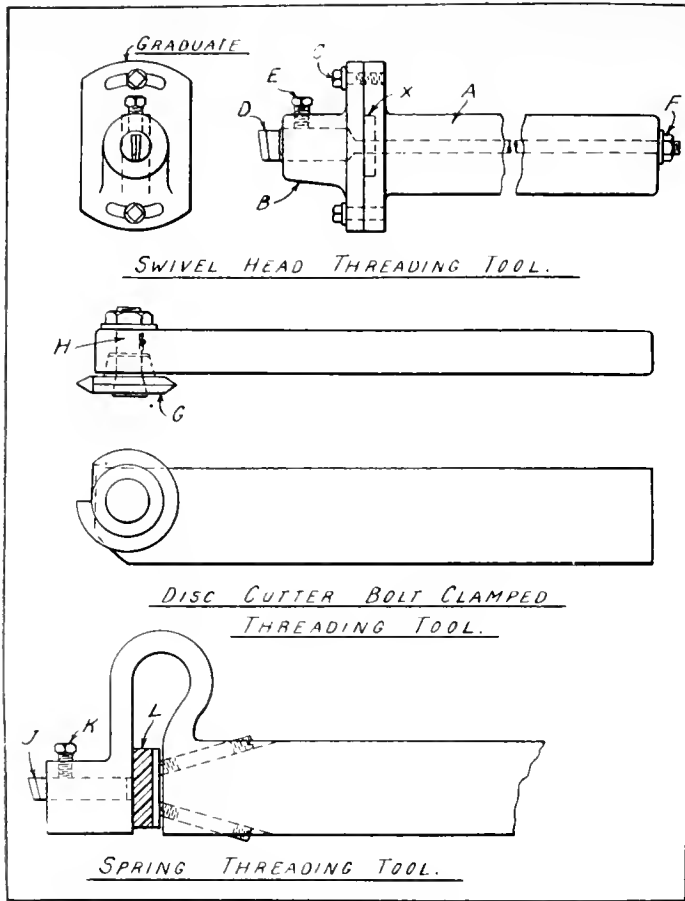

FIG. 17. SWIVEL DISC AND SPRING THREADING TOOLS OF TYPICAL DESIGN.

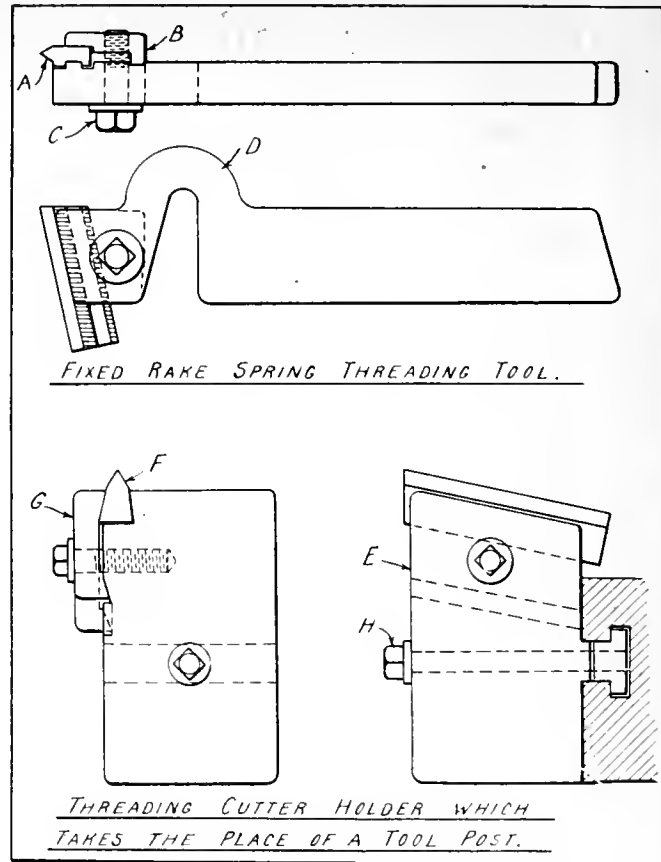

FIG. 18. TWO TOOLS USED FOR THREADING.

The lower view in Fig. 17 shows a threading tool of this type. This tool holds a cutter J, which is clamped by the set screw K. The holder is made in the form of a spring with a hard rubber (or other suitable material) pad L between the holder shank and the part which holds the cutter. This pad is held in position by the two set screws shown, and acts as a butt against which the tool holding portion of the holder comes as it tries to spring away from the cut. By means of the two set screws the amount of elasticity in the tool may be regulated to some extent.

Another spring threading tool which holds the cutter at a fixed clearance rake is illustrated in Fig. 18. In this the cutter A is tongued into the holder, and is clamped by means of the strap B and screw C. The cutter has teeth milled in the side, and when clamped in position will not slide down under a heavy cut. The neck of the tool D must be stiff enough to resist the cutting strain while remaining slightly flexible. In the lower view of Fig. 18 a thread cutter holder, which takes the place of a regular lathe tool post, is shown. This holder is in the form of a block E, which is mounted on cross slide of the lathe. In this block the cutter F is held in the manner shown, and is securely locked in position by means of the screw G, while a screw H holds the block on the cross slide.

Another type of cutter which is quite extensively used in threading is known as a serial point cutter. These cutters are made with a number of teeth, each

succeeding tooth being made to remove slightly more than the preceding one. Many of the thread tool holders previously described will handle these serial tools, and the illustration, Fig. 19, shows a thread tool holder in the form of these cutters. The upper illustration in the centre shows a straight holder and

an off-set holder. In these the cutter is tongued into the holder, and they are clamped by a screw, which is tightened by a pin wrench. The upper view at the left shows a plain single point cutter, while the upper view at the right shows a single point cutter which cuts the angular portion of the thread, and also cuts the shape at the top of the thread, as in cutting "Whitworth" threads. In the lower view at the extreme left, two off-set single point threading cutters are shown, one of them being but slightly off-set, this being only noticeable on account of one side of the angle being longer than the other. The other, however, is off-set to such an extent as to be very noticeable. In the lower middle views of Fig. 19, a fine and coarse pitch serial threading cutter is shown, while the remaining view at the right shows a threading cutter of a very coarse pitch.

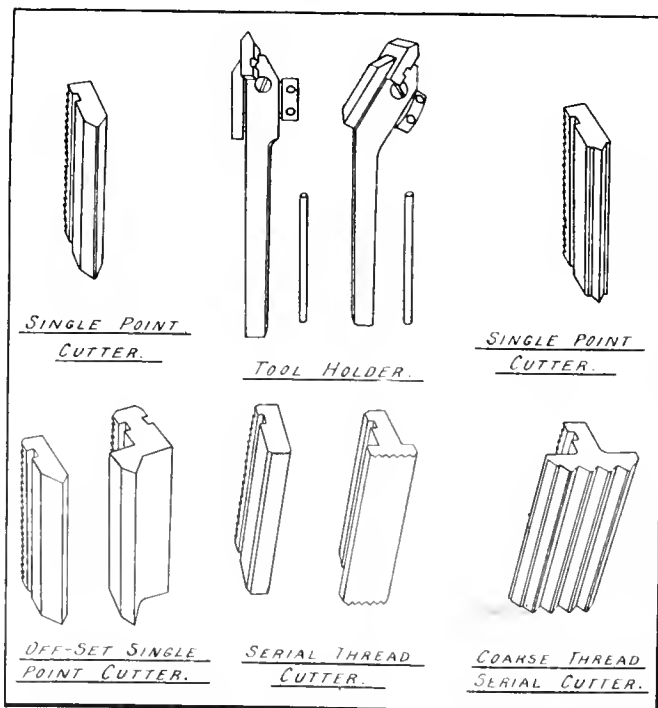

FIG. 19. STANDARD TYPE OF THREADING TOOL AND HOLDER.

Boring Tools

In regard to the problem of boring tools, these are quite varied in design, and consequently but four types will be described in this article, these being confined to lathe boring tools. The first of these shown at the top of Fig 20 is a boring tool holder, which takes the place of a tool post. The view below shows a boring tool which is quite generally used for boring on the milling machine, but may be used to good advantage for some classes of work on the lathe. When used on the lathe it is held in either the lathe spindle or the tailstock spindle, and the cutter is, of course, adjusted by means of the key shown in position at A. This tool bores independently of the cross-slide. An off-set boring tool is shown directly below this. The manner of using the tool is obvious from the illustration, and it might be termed an extension tool post, as it is used similar to the regular tool post while being in turn held to the latter. In the lower view of Fig. 20, a boring tool which replaces the lathe tool post, and will carry a number of different sizes of boring bars, is shown.

Two types of lathe knurling tools, with a group of knurls, are shown in Fig. 21. The principle involved in these two tools is as follows:—The tool at the top contains two studs A and the angular arms which carry the knurls; these are adjusted by the screw B. In the tool holder shown below, this is accomplished by means of a nut C which adjusts the arms

D in a vertical plane. This adjusting of the knurls is necessary in order to make them conform to the diameter of the work being machined. In the group of

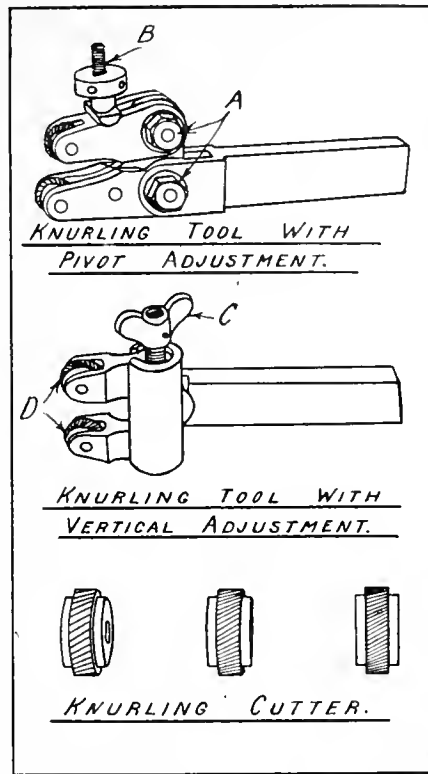

FIG. 21. TWO LATHE TOOLS USED FOR KNURLING.

knurls shown below, a fine, medium, and a coarse cut knurl are shown.

In presenting this series of articles, it has been the writer's purpose to confine it to the subject of ordinary lathe and planer tools, while avoiding the numerous cutter heads of special design for single purposes; also to show a number of holders which will give good results in their respective fields.

INCREASED TAX ON WAR PROFITS

THE resolution brought down by the Minister of Finance, in the House at Ottawa, to give effect to the proposals contained in his budget speech provides:

1—That in any business taxable under the Act where the annual profits exceed 15 per cent. per annum, the tax shall be increased to 50 per cent. with respect to all profits in excess of the said 15 per cent., but not exceeding 20 per cent. per annum, and where the profits exceed 20 per cent. per annum the tax shall be increased to 75 per cent., with respect to all profits in excess of the said 20 per cent., and such increases as the tax shall be levied against and paid by the person owning such business for each and every accounting period ending after the 31st day of December, 1916.

2—That for the purposes of the said Act, the actual unimpaired reserve, rest or accumulated profits shall, at the commencement of an accounting period by an incorporated company, be included as part of its capital as long as it is held and used by the company as capital.

That any enactment founded on this resolution shall be deemed to have come into force on and from the 18th day of May, 1916.

3—That the tax shall be paid each year within one month from the date of the mailing of the notice of assessment.

4—That with respect to every business liable to taxation hereunder the period for which the returns shall be made and during which it shall be liable for assessment shall be at least thirty-six months, commencing with the beginning of the first accounting period ending after the 31st day of December, 1914, or for such less period as the business may have been carried on from the beginning of the said accounting period to the end of the period for which the said tax may be levied under the said Act.

The following table illustrates the division under the new Profits Taxation Act of a company's profits between the company and the Government:

Profit	Company	Government
10 p.c.	9¼ p.c.	¾ p.c.
15 p.c.	13 p.c.	2 p.c.
20 p.c.	15½ p.c.	4½ p.c.
25 p.c.	16¾ p.c.	8¼ p.c.
30 p.c.	18 p.c.	12 p.c.
50 p.c.	23 p.c.	27 p.c.
100 p.c.	35½ p.c.	64¼ p.c.
200 p.c.	60½ p.c.	139½ p.c.

BIG INCREASE IN DOMINION TRADE

CANADA'S total trade during the fiscal year ended March 31 last exceeded that of the previous financial year by over eight hundred million dollars. Hon. J. D. Reid, Minister of Customs, announced on April 24 that the trade for the year recently terminated amounted to \$2,249,170,171, of which \$225,000,000 was in coin and bullion, as compared with \$1,424,916,665, of which \$140,000,000 was in coin and bullion in 1915-16.

The exports for the year 1916-17 aggregated \$1,151,375,768, as against \$741,610,653 in the previous twelve months. Indeed, the great growth in trade was largely due to the expansion in exports of manufactured and agricultural products.

The exports of domestic manufactures increased from \$242,034,998 in the fiscal year of 1915-16 to \$477,399,676 in 1916-17; agricultural products increased from \$249,661,194 to \$373,413,701; export of animals and their produce from \$102,882,276 to \$127,795,468; products of the mines from \$66,589,861 to \$85,616,907.

Imports grew from \$507,783,361 in 1915-16 to \$845,330,903. Of the imports the dutiable goods accounted for \$461,708,206 and free goods for \$383,622,697. The Customs revenue was \$147,623,230 in 1916-17, as compared with \$103,929,126 in the previous fiscal year.

A leading firm of motor-car builders in England have just been granted a patent on a magnetic non-return valve in which the valve proper is made of hardened magnetized steel and the part of the body on which the seat is formed is of magnetic metal, such as iron.

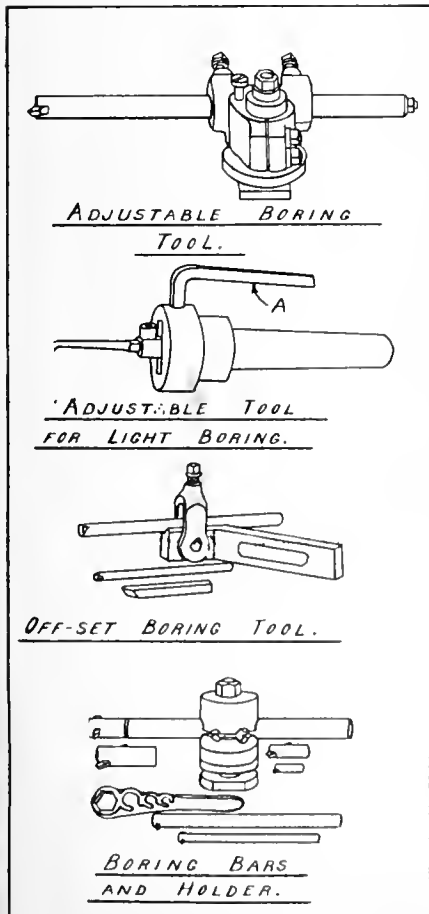
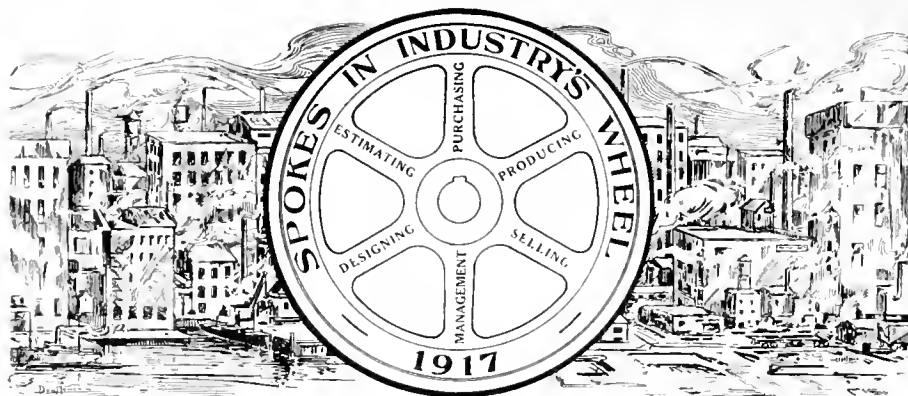

FIG. 20. TOOLS OF STANDARD DESIGN USED FOR BORING.



The constitution of industrial enterprise is largely departmental—"spokes in a wheel." This series of articles has for its object the featuring in a rare, interesting and instructive fashion, the training, experience and achievement of those who to-day are transmitting, effectively, energy in their capacity as "spokes in the wheels" of our metal-working establishments.

WILLIAM NEWMAN

SOME years ago, when a certain shipbuilding yard in the States was making fame for itself through the construction of fast Atlantic liners, it was related of the principal partner that he could go into any department of the plant and replace any workman himself. This thoroughness of training was the formation and mainstay of a particularly close understanding between management and employees, and the almost unique record for efficiency and freedom from trouble in the plant referred to was largely due to the conditions mentioned. Those of our readers acquainted with William Newman, works manager and naval architect of Polson Iron Works, Ltd., Toronto, Ont., will recognize in his interesting career a striking parallel to the conditions related in the opening paragraph. To have developed an intimate knowledge, through personal experience, of all stages in lake shipbuilding from dock newsboy to manager of one of Canada's largest shipbuilding plants is the meantime measure of our Spoke's accomplishment.

Born in Kingston, Ont., Oct. 31, 1873, the son of William Newman and Mary Dehaney, the subject of our sketch early developed that inborn love of boats which was to ultimately influence his life in such large measure. While still at school the attraction of the water was so great that his spare time after school hours was spent in selling papers on the mail boats and other craft with which the waterfront was thronged. With the finish of school days, life's serious work had to be decided on, and accordingly at the early age of 13 years, the "call of the deep" was temporarily suppressed when an apprenticeship was commenced in the Canadian Locomotive Works in his native town. From 1886 to 1890 the duties of a machinist were discharged with considerable ability but even the four years spent in the shade of locomotives did not alter the destiny of our young friend, the "lure of the lake" being so irresistible that imme-

diately his machine-shop apprenticeship was finished he went back to the boats and started to serve his time as an apprentice shipwright in the shipyards of Capt. Robert Davis and the Montreal Transportation Co.

His ability in marine matters was so marked that in the short space of three years he had advanced to the position of foreman in the latter Co.'s yard, a post which he held from 1893 to 1901. The experience which Mr. Newman thus obtained during the receptive period of



WILLIAM NEWMAN.

his life was later to prove of particular value in equipping him for the discharge of ever-increasing responsibilities. During the last six years of this time he did submarine diving for the M. T. Co., and the Donnelly Salvage & Wrecking Co., raising, dry-docking and repairing boats.

From 1901 to 1903, Toronto was the scene of his labors as foreman with the Bertram Shipbuilding Co., which posi-

superintendent for the late Frank Simpson, superintendent for the late Frank Simpson, C.E., public works contractor, for whom he had charge of laying the six-foot conduit from Lake Ontario to the tunnel under Toronto Bay. All of the floating plant required for this contract was designed and built by him.

On the death of Mr. Simpson in 1908, Mr. Newman became superintendent of the Polson Iron Works, and three years later made a tour of the important shipbuilding plants in Great Britain, France, Belgium, Holland and United States. In the same year, 1911, he was promoted to the post of works manager, and in 1913 undertook the additional duties of naval architect. Mr. Newman looks forward with considerable gratification to the near future when the launching of a number of vessels will mark the completion of the half century of launchings under his supervision, the first of the fifty being the Earl King, launched in 1909.

Notable amongst the work executed during the tenure of his present position are the designs for the big dredge Port Nelson which was built in four months, also the stern-wheel steamer and three steel steam lighters for the Government work at Port Nelson, Hudson Bay. A surpassing effort which is expected to materialize in the near future, however, is a 500-foot electrically operated, steel floating dry-dock, which is to be constructed for the Polson Co.

Mr. Newman's activities further include the managership of the Canadian branch of the American vessel fire register; while he is a member, Naval Architects and Marine Engineers Association, New York; associate member, Institute of Naval Architects, London, Eng.; hon. member, Canadian Society of Marine Engineers; member, Toronto Board of Trade; hon. member, Canadian Quoit Club. He is the possessor of a gold medal presented by the council and citizens of his native city for saving the lives of two women from a burning building while a volunteer member of the fire department, Oct. 2, 1897, and also wears the Diamond Jubilee Medal awarded to representatives of Canadian troops in England on that occasion. His military service includes a twelve-year membership of the 14th Regiment P.W.O.R.; on the outbreak of war he was granted a commission in the 23rd Regiment Northern Pioneers, and is now Captain of No. 5 company.

Mr. Newman owes his success to a large extent to hard work and close attention to details believing in the old adage that it is the little things that count. This principle he has applied to his work with conspicuous success. Some years ago Mr. Newman had the good fortune to meet the late Sir William White the celebrated naval architect, and was much impressed by his personality and kindly advice received on several occasions. Our "Spoke" advises all budding marine engineers to study the career of some man prominent

in his profession and considers that no better incentive can be found than in the life of Sir William White, one of whose chief characteristics was a mastery of detail.

While he may deny the fact, our "Spoke" owes not a little of his success to a genial and thoughtful temperament fostered by a study of human nature. During the early part of his career, his occupation gave him plenty of opportunity for observing his fellow men. The knowledge gained has been a valuable asset since, particularly in his present position where he has charge of a large number of men. It is said that when Polsons began to get busy again some eighteen months ago, many old hands who had left when business became slack, returned immediately from all parts on hearing that there was work for them at the old shop. This in itself speaks well for the firm and those in authority.

Mr. Newman being essentially a practical man believes in the practical end of the business. At the same time he strongly advocates the acquisition of the same theory by attendance at night school or college and also by the reading of technical books and journals. He holds that this is necessary for a proper and intelligent understanding of hand books which are of great assistance to those engaged in the construction of ships in any engineering capacity either in the shop or in the drawing office. In his younger days Mr. Newman spent practically all his spare time on study and is deeply indebted to Frank Simpson, for whom he worked at one time, for much valuable assistance and encouragement. He also attended evening classes at Wells Business College, Toronto.

Mr. Newman also states that "there is no institution in Canada where naval architecture is taught, and marine draughtsmen are brought here from Great Britain, Sweden, Denmark and the United States. I think some of our Universities should have a chair in Naval Architecture, as they have in the University of Glasgow and in the School of Technology in Boston, as at the present time, such important positions as loftsman, ship's plater, and ship's carpenter are practically closed to Canadians. There are scarcely a dozen apprentices in Canada to these departments, and outside of the "Old Guard" of ship's carpenter, 90 per cent. of our skilled labor in these branches are brought from outside the Dominion.

"Another industry which Canada must soon take up is the manufacture of ship plates and shapes; also of seamless steel tubes and corrugated furnaces. With her immense wealth of ore, nickel, copper and coal, and her unlimited supply of timber in British Columbia, I see no reason why Canada should not in the future become independent in the ship-building trade—something which she is far from being at this writing."

CANADA'S SHELL-MAKING ACHIEVEMENT

THE story of Canada's achievement in the manufacture of munitions was told to the Ottawa branch of the Canadian Society of Civil Engineers on April 25, by Colonel D. Carnegie, a member of the Imperial Munitions Board. He said that when the war broke out Canada's capacity for shell making was confined to three hundred and forty 18-pdr. shrapnel shell per week. Now, she had capacity to turn out 400,000 of the latter per week, including cartridge cases, fuses, propellant, etc., in addition to 400,000 high explosive shells of all varieties—or 800,000 shells per week. To manufacture this huge quantity of munitions requires 25,000 tons of steel per week, 2,500 tons of brass, 750 tons of copper, 250 tons of zinc, 1,500 tons of lead, 200 tons of antimony, 150 tons of resin and 1,300 tons of explosives. The making of boxes required 325,000 lineal feet per week.

Colonel Carnegie said the total value of the shell orders let in Canada had reached the enormous sum of \$800,000,000, and there had been shipped to date \$500,000,000 worth to France. He emphasized the difficulties at the outset of the manufacturers in making shells. There was difficulty in getting machinery, and a still greater struggle to secure adequate and trained labor. The greatest of all progress had been made by the workers; the skill they had acquired had passed all expectations. So skilled were the Canadian workers now in speed and output that they would excite the admiration of the oldest and most experienced machinists in England.

Shell Factories

There were now 650 factories, distributed through 144 towns (in every province except Prince Edward Island) engaged in turning out shells. He told of the difficulties in securing shell forgings, and the work which was now being accomplished. The value of the steel forging plants was approximately \$5,000,000. There had been installed in Canada's factories 18,000 machines for the manufacture of shells, valued at \$35,000,000.

In the early stages of the war all our gauges came from the United States, but to-day there were twenty factories in Canada making gauges, and \$150,000 per month was spent for gauges. The Imperial Munitions Board had five thousand inspectors, under Colonel Edwards. Col. Carnegie said one of the first projects undertaken by J. W. Flavelle, the present chairman, when he took over the work of the Board, was to establish national factories for the manufacture of shells. To-day there were national factories for loading fuses, making explosives of various kinds, acids and aeroplanes. These were operated by separate companies, the entire stock being held by the Imperial Munitions Board. At the present time the factories are turning out one aeroplane a day, and when the new factories shall

have been completed they will have a capacity of five aeroplanes daily.

A Permanent Asset

The factories which had been developed for munition making, he said, would be a permanent asset to Canada for two reasons, first, they had standardized products, and second had standardized skill. No component parts of shells were accepted except under rigid examination, and strict test. Every industry which had been engaged in the manufacture of munitions had passed through processes of refinement. They would return to normal industry after the war much more skilled and competent than before. Munition manufacturing had given an abiding impetus to mining in Canada. The chemical industry, he said, had been accelerated. The electro-chemical industry, such as refining copper, which had been developed in the last two or three years, would remain a permanent industry after the war. Every workshop engaged in the munitions industry had standardized skill, which was a permanent asset to Canada. There are now no less than 25,000 skilled workmen, and 12,000 women engaged in munitions manufacture.

Colonel Carnegie predicted an industrial war when peace comes. Germany had been piling up products, which would be thrown on the world's market, and there will be the keenest competition for world commerce. German militarism might be crushed, but German industrial life would be probably stimulated by the war. There would be a struggle for industrial supremacy, and it will take all the ability and experience of Canadian manufacturers to hold their own in this struggle.



SUBMARINE CONSTRUCTION ON PACIFIC COAST

CONSIDERABLE interest is taken in Vancouver's latest acquisition in the way of shipbuilding contracts, particulars of which have just been announced. J. V. Paterson, of Seattle, former president of the Seattle Construction & Dry Dock Co., and one of the best known shipbuilders and marine architects on the Pacific Coast, has closed contracts to build six submarines for the Russian Government. The work will be done at a plant which Mr. Paterson has built in Vancouver, and actual construction of the submarines has been started. Material for all of the half dozen is already on the ground and the plant practically completed, with a force of 150 men now at work. This force will be increased immediately to 350 men, as, while the definite dates of delivery of the vessels are not given out, Mr. Paterson states that they are wanted as quickly as possible.

The order for the submarines is the largest for war vessels for a foreign power yet placed on the Pacific Coast, and is believed to be the only one now pending in Northern yards. A year and a half ago Mr. Paterson built five submarines for the Allies, but he states that these later craft are of a larger and more powerful type than the former order.

EDITORIAL CORRESPONDENCE

Embracing the Further Discussion of Previously Published Articles, Inquiries for General Information, Observations and Suggestions—Your Co-operation is Invited

MACHINISTS' INSTRUCTION COURSE—XIX

By J. Davies

AFTER deciding how any particular job is to be held in the milling machine, the next point is the selection of a suitable cutter. This is a matter of judgment based on practical experience depending on the nature of the job, the construction of the machine, the rigidity with which the work is held, and last but not least the available supply of cutters to choose from.

Choosing a Cutter

It is quite a common thing to see a milling machine run at considerably less than its maximum capacity for want of suitable cutters; in many cases it is Hobson's choice, this or none. The cutter that will do the work satisfactorily in the least time is the cutter for the job. In a job that would require a number of short cuts, time can be saved by using a cutter of small diameter as a small cutter will pass over a job in less time than a larger cutter would, that is if equal feeds are used. If, however, by using a larger cutter, the greater number of cutting edges on the large cutter would allow an increased feed, nothing would be gained by using a small cutter.

It is very important to keep milling cutter sharp, so much so that many manufacturers have stamped on their milling cutters the words "Keep Sharp." It has been proven that a milling cutter will last much longer if kept absolutely sharp, than it will if used in a dull condition. The dull cutter puts an unnecessary strain upon the machine, the work, and also upon the arbor carrying the cutter, besides the tendency to generate heat in itself and become soft.

Avoid Fine Teeth

Do not choose or make your milling cutters with very fine teeth. It is a mistaken idea to suppose that the finer the teeth the finer the job, or that you can do a job quicker with a milling cutter with fine teeth on account of the greater number of teeth than you could with a wider spaced cutter of the same diameter. If the teeth of your cutter are too fine they are liable to become choked up with cuttings as there is very little chip clearance and you may have to keep on brushing away the chips that have become packed between the teeth.

A proper application of some cutting compound will prevent the chips from clogging up the spaces between the teeth, partly by washing away the chips and partly by changing their character or form, but the chief benefit derived from flooding the work with some kind of lubricant is that it keeps the work and cutter cool and so preserves the cutting edge, allowing a

higher rate of feed and speed than would be otherwise possible.

No lubricant is necessary for cutting cast iron, that is soft grey iron, or for yellow brass. For steel, wrought iron, malleable iron, etc., some sort of lubricant is advisable. Lard oil makes a very efficient lubricator for nearly all classes of work, but owing to its cost some sort of soda compound is often used instead. If there is no pump or other mechanical means of applying the cutting compound use a stiff brush and apply to the side of the cutter running away from the work.

Testing the Setting

After securing your work, make a final test to see that it has not moved by the tightening of bolts or clamps. The setting of work that has been secured to the table may be tested for being parallel by a surface gauge from the table, in the same manner as testing a job on the planer. If there is no room on the table or for any other reason a surface gauge cannot be used, a pointer fastened between two washers on the arbor may be used and the table moved under it. A convenient method of setting up an angle plate, parallel with the line of motion of the table, is to put a pointer between two washers on the arbor and bring one end of the plate up until it just touches a feeler or piece of paper placed between the pointer and the plate; then move the table to the other end and test again and adjust until the paper is punched equally at both ends.

For small work the commonest way of securing the work is by a vise the base of which should be graduated in

movable, so that special jaws could be made to suit any particular job.

Direction of Feed

Always feed the work against the cutter unless the machine is especially built to feed either way. Some machines are arranged to take care of the backlash existing between the feed screw and the nut, the table being prevented from jumping forward by a weight attached to a cord or chain which passes over a pulley in line with the table. If there is no such appliance always feed against the work Fig. 71 or the cutter will probably draw the work toward itself and climb over it, resulting in a broken cutter or a bent arbor or both.

When setting up work in the vise or on an angle plate where there is a risk of the work slipping, arrange the work so that it will slip from the cutter and not towards it. In taking a light cut that finishes against a radius or shoulder as it is called, be careful as the cutter approaches the end of the cut,—take off the feed and feed very carefully by hand, because if the cutter is allowed to come against a larger mass of metal than it is cutting with any force it will undercut the job. The same remark applies to cutting slots with an end mill—if a slot is cut with an end mill cutting both sides at once, then when the work is fed over again in the opposite direction, the slot will be found to be larger than the mill. The proper way to cut slots is to use an end mill having a diameter slightly less than the width of the slot, and take two cuts one for each side of the slot. If the job must be done in one cut, avoid the common error of set-

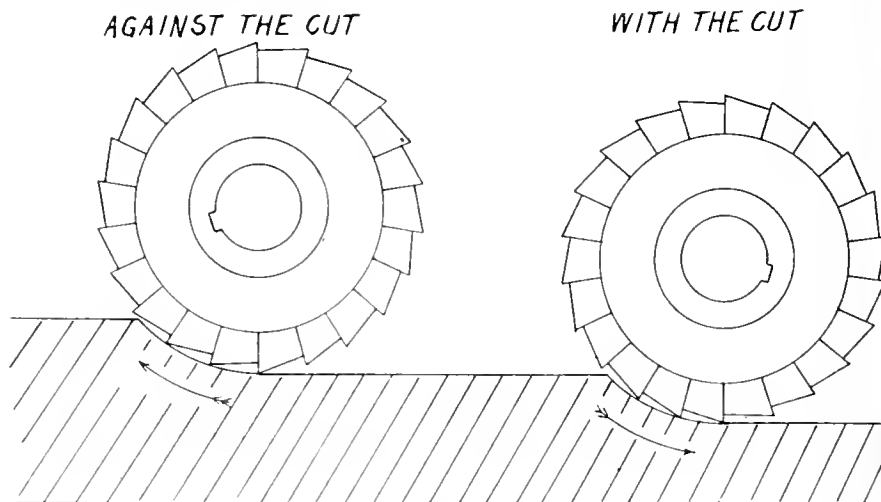

FIG. 71.

degrees, and have a tongue on the underside to fit one of the slots in the table to ensure it being parallel with the table. The jaws should be of steel and re-

ting up the work to cut an equal amount off each side, as the resistance on the side of the mill that is against the cut is not equal to the resistance that is

on the side with the cut. This fact is responsible for more than fifty per cent. of broken teeth in end mills. Set up the work so that the cutter will remove about twice as much from the side that is feeding against the cut as it will from the side that is with the cut. Also be careful in starting the cut, especially if starting to cut against a square shoulder or the square corner will run in between two teeth and rip a few of them out of the cutter before the damage can be prevented.

DOESN'T BELIEVE IN SAVING TIME.

By N. G. Near.

BOILER factory owners still exist who think they have sound arguments against good time-saving devices. They believe in the old idea—plenty of “elbow grease” as they called it. They think it laziness to permit the brain to do the work through coal and machinery.

I met a friend salesman the other day who told me about an argument he had with such an owner of a boiler factory. He had tried to sell the owner an up-to-date, time-saving machine, but the owner said, “If we used every time-saving device in the world in this factory we wouldn't have anything more to do.” Although it is usually fatal for a salesman to be sarcastic with a prospective buyer, this friend of mine said, “Your're right. Henry Ford believes in using as much time-saving machinery as possible in his automobile factory, and that is why he hasn't anything to do now-a-days.”

It's a fact that some so-called time-saving machines are actually time-losers and they should be carefully weeded out. Again, the time-saving machine may be a time-saver only where it can do jobs over and over, and where it can be kept everlastingly at it. In many instances, holes can be drilled in certain pieces by hand more quickly and more economically than by machinery, and such machinery may be the so-termed “time-saving” variety.

If TIME was MONEY in Ben Franklin's day, doesn't it seem reasonable that time is worth MORE money now?

SETTING A LATHE IN POSITION

By N. E.

UNDUE haste in the setting of machinery is often the cause of subsequent trouble in its operation, much of which may eventually be laid upon the shoulders of the man working it, while in reality it is the machine itself that is responsible for the inefficiency. Neglect in paying sufficient attention to the primary essentials when installing machinery often demonstrates the truth of the saying: “More haste, less speed.” Like everything else of lasting value, from the formation of character to the erection of a large building, the nature and permanency of the foundation is the all-important factor. Unless a good foundation is provided for the lathe, it is quite unreasonable to expect that satisfactory work will be produced. Un-

doubtedly, the chief consideration in the placing of an engine lathe should be the entire elimination of structural stress when setting in position. The legs of a lathe are not alone for the purpose of elevating the mechanism to a convenient working distance from the floor, but they must also be the means of maintaining the bed in its proper alignment; and this is only possible by the relative distribution of weight between the various supports. To attain this, it is necessary that the floor (preferably a special foundation) be previously prepared to receive the machine. A lathe that is not properly leveled cannot be depended upon to perform accurate work. No lathe is so rigid in the bed but that it will develop a “spring” when resting on uneven supports. Spring, no matter how moderate, is detrimental to the accomplishment of good work; irregularity in boring, facing or turning, may result, and clattering may also be one of the faults.

When leveling up a lathe, a fairly sensitive level should be used; one that will respond to the slightest variation from a set position. Thin wedges may be used to attain the objective, but it is more reliable to use suitable liners under the feet that will furnish a wider support than is possible with the wedge, as the sharp edges of the foot of the leg will in time cut into the wedge, thus allowing that corner to sag, and consequently destroying the original setting of the machine. With proper assurance that a lathe has been properly leveled upon its foundation, any faults that may subsequently arise can readily be traced to other causes.

MISTAKES THROUGH VERBAL INSTRUCTIONS

By B. S.

WHO must take the responsibility when errors occur through the misunderstanding of verbal instructions? The inability of any two minds to think exactly alike is often the cause of varying degrees of error in the accomplishment of certain tasks, if there is nothing tangible to verify the orders previously given. In many lines of work, slight divergence from accepted practice matters little in the final achievement, but in other lines of activity it is essential that specific instructions be adhered to, in order that the final result be in keeping with the original intention. In the case of a foreman issuing instructions to a workman regarding the construction of a certain piece of mechanism, it sometimes happens that insufficient details are given the workman for the thorough knowledge of the task before him. The foreman undoubtedly, has given the question much thought before it is submitted to the workman, and when this is done, the instructions are issued from the viewpoint of the foreman who has previously studied the various phases of the subject. The workman, not being a mind reader, thinks he has understood the orders given and proceeds to perform the work, based on the meaning he has taken from

the instructions given, with the result that the operation is not accomplished as the foreman had intended.

A case in point was that of a tool-maker receiving instruction to make a forming die to accomplish certain operations. A few brief verbal suggestions, outlining the method of procedure, were given by the foreman, and the workman proceeded to construct the tool according to the understanding he had of the chief's remarks. The die was completed and worked satisfactorily, but the ideas of the workman had varied from those of the foreman to such an extent that the latter was not convinced but that his way would have given still better results.

On another and later occasion, the same shop was confronted with a more complicated problem, that of a stamped piece for which dies had to be constructed. Considerable thought had been given on the part of the superintendent and foreman as to the method of designing the tools, but nothing definite was arrived at when the work was handed to the tool maker with a few brief verbal suggestions as to the purpose of the piece and the method of producing same. In some respects, the workman was given free scope as to the construction of the die, and commenced operations based on his own particular ideas as to what was desired. It chanced, however, that after considerable time and labor had been put upon the tools, the superintendent happened around and told the foreman that the work was not being done as intended, and a general mix-up immediately followed; the outcome of which was an all-round discussion, as to the correct method of construction. There at once arose the question as to who should shoulder the responsibility, as it was not clear just what the original instructions had been. However, after thrashing out the subject from various angles, sketches were developed from the different suggestions that provided a foundation for the construction of the tools, and also indisputable evidence as to workman's instructions.

Definite information, either in the form of sketches or writing, should be issued for the guidance of the workman, where the reasoning factor of the human element is a feature of production. By strict adherence to this rule, better protection is provided for both the foreman and the workman, and will often avoid many of the troubles and misunderstandings common to job shop and special manufacturing practice.

It is a common observation by plumbers that the pipes carrying the hot water from the boiler to the kitchen and bathroom burst from freezing far more frequently than the pipes carrying the cold water. Experiments have been made with glass tubes, the practical conditions being simulated as nearly as possible. The results confirm the above observation, and show that the occluded air in tap water is responsible for the delay or absence of bursting of the pipes, says F. C. Brown in the *Physical Review*.

Development of Wood and Steel Shipbuilding in Canada

By C. T. R.

In addition to the widespread requisitioning of vessels for transportation purposes by the Allies, the war attendant and normal merchant ship losses and the many months' almost complete cessation of new construction on the part of the latter, the merchant marine of the world has had the misfortune to become to a large extent the target for enemy submarine activity. All nations have suffered in this respect, hence the almost feverish anxiety being displayed by shipping interests to have the losses made good at the earliest possible moment.

UPPER LAKES S.S. "WESTMOUNT" LAUNCHED

THE bulk freighter Westmount, which has been built to the order of the Montreal Transportation Co., by the Collingwood Shipbuilding Co., Collingwood, Ont., was successfully launched on April 5, Mrs. L. L. Henderson, wife of the president of the owners company, christening the vessel. The "Westmount" is one of the largest vessels yet constructed in Canada, and is of the single-deck type which has been evolved to meet the conditions prevailing on the Great Lakes of North America in regard to the transportation of bulk cargoes of coal, ore and grain. Her leading particulars are: Length over all, 550 feet 8 in.; length B. P. 537 ft.; breadth moulded, 58 ft.; depth moulded, 31 ft.; load deadweight, 11,000 tons; load draught to suit canals, 19 ft. 6 in.

Loading and Unloading Provision

The vessel, in common with the other

ing quick despatch in port a matter of the utmost importance. No loading or discharging appliances are provided on board, these operations being accomplished by the shore plant. There are 16 cargo hatchways, each having a width of 38 ft. and a length of 9 ft. The hatchways are spaced 24 ft. apart centre to centre to suit the standard spacing of the loading and unloading devices on shore. Between the hatchways, strong arch girders or web frames, extend right round the sections. By the adoption of these girders stanchions are dispensed with and the holds left unobstructed, a necessary feature where coal and ore cargoes are unloaded by clam-shell buckets, as is the case on the Great Lakes. For the same reason there are no deckhouses, spars or other obstructions for the length of the cargo holds.

The ordinary transverse bottom and side frames are of channel sections and are spaced 3 ft. apart. The double bot-

deck stringer, and thus form a double skin to a height well above the deep load line. The side tanks provide large additional capacity for water ballast, while their inner plating transforms the hold into a compartment of hopper form section, eminently suitable for mechanical unloading operations.

The tank top plating, which carries the weight of the cargo, is supported by the centre girder and by four continuous longitudinal girders on each side of the centre line. Intercostal deep floor plates are fitted in the transverse direction at every second frame, i.e., 6 ft. apart, there being a deep floor at each arch girder and one between. There are two collision bulkheads forward, the space between forming a deep tank.

The cargo hold is divided by screen bulkheads into six compartments and the double bottom by four watertight divisions into five compartments for water ballast. The remaining bulkheads are a cross bunker screen bulk-

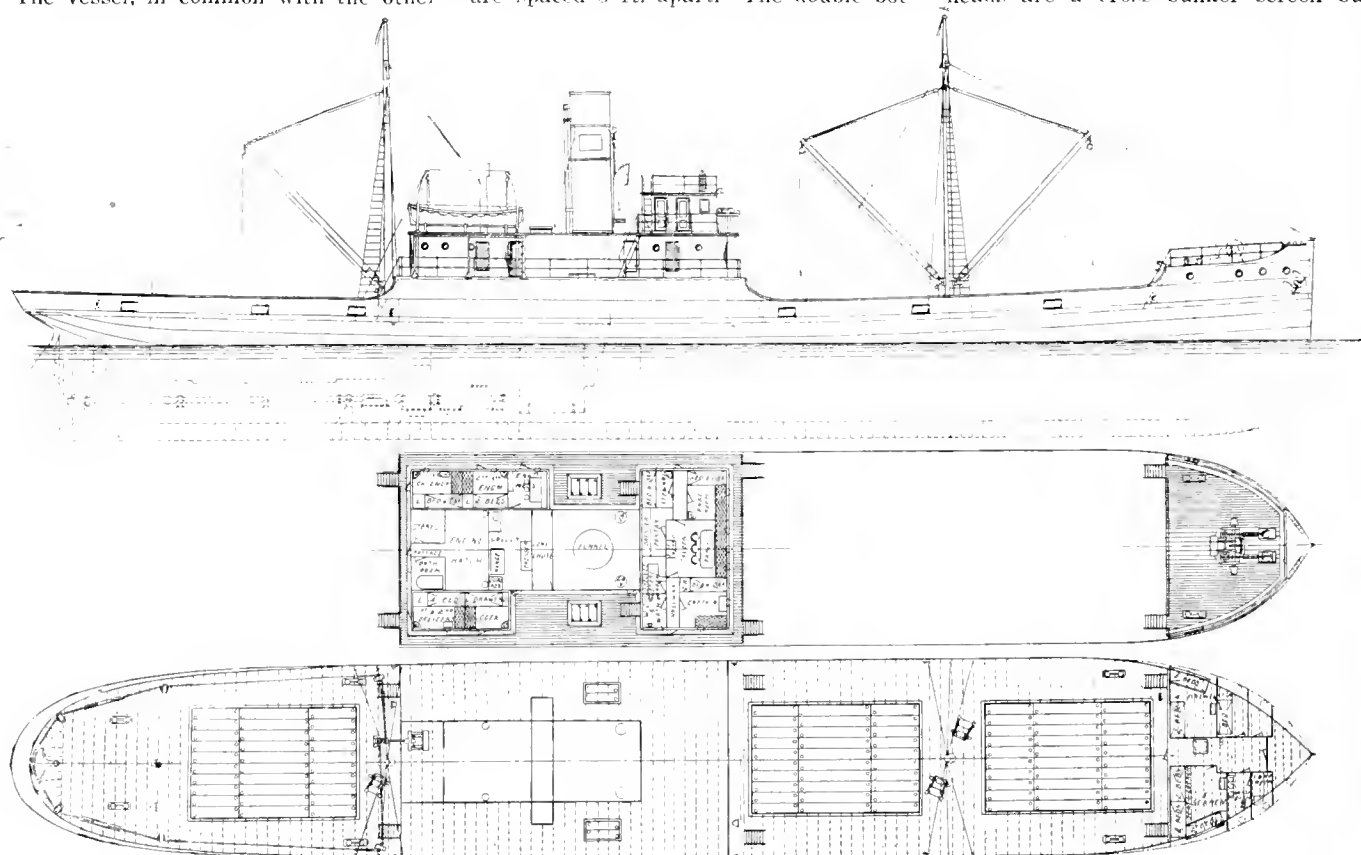

STEEL OCEAN-GOING FREIGHTER BUILDING BY NOVA SCOTIA STEEL & COAL CO., NEW GLASGOW, N.S.

ships of her class, embodies a number of features introduced to facilitate loading and unloading operations, the short season for navigation on the lakes mak-

tom, which is 5 ft. deep, extends for the full length between the peak bulkheads. Side tanks of the same width extend on each side up to the level of the main

head, a screen bulkhead between the engines and boilers, and a watertight after peak bulkhead. The upper deck stringer and plating between the hatch

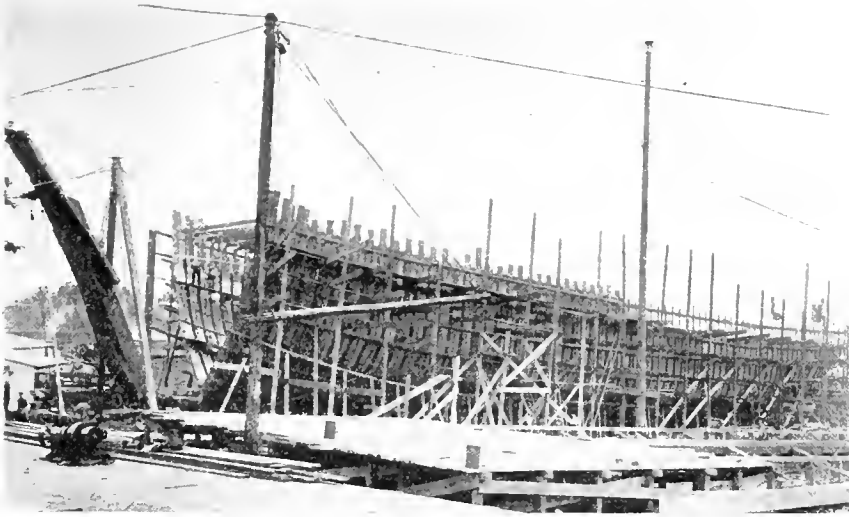

AUXILIARY POWER SCHOONER "MARGARET HANEY" ON THE STOCKS.

and ship's sides are supported by longitudinal channel girders instead of transverse beams. This arrangement is a new feature in a vessel framed on the transverse system, and has the advantage of introducing additional longitudinal strength at a very desirable part.

A short forecastle is fitted above the upper deck right forward. On the port side under the forecastle deck are arranged cabins for the first and second officers, the quartermasters, and watchmen. In a corresponding position on the starboard side are the owner's state-rooms. On the forecastle deck above is situated a large steel deck-house containing an observation room and the captain's quarters. The top of this house forms the navigating bridge, upon which stands the wheelhouse.

The accommodation provided at the after end of the ship is arranged in a large steel house surrounding the engine and boiler casing. Here are placed the engineers' quarters, galley, dining-rooms for the owner, officers, and crew, respectively, and berths for various members of the crew. The firemen's accommodation is situated on the main deck at the starboard side just abaft the engine-room casing.

Ship Deck Machinery

A powerful steam windlass, of the Emerson-Walker quick-warping direct

grip type, is located on the upper deck forward under the forecastle. The cables are 2¼ in. in diameter, each being attached to a "Britannic" stockless anchor of 8,000-lb. weight. The anchors are stowed in suitably shaped pockets,

by 9 in. steam engine supplied by the American Engineering Co., of Philadelphia, which actuates the rudder directly through a toothed quadrant connected to the rudder stock. This gear is controlled by wires led from the steering wheel in the pilot-house or that on top of same. The emergency gear is always under steam, and can be put into operation in a few seconds by means of a crank on the bridge steering standard, which at the same time throws out of action the main gear.

The deck winches, which number six in all, have been supplied by the Chase Machine Co., of Cleveland. Four of these are 8 in. by 10 in. single-drum mooring units, and are placed two at each end of the row of hatchways. The drums of the mooring winches are arranged in an athwartship direction, fairleads of special design being provided at the ship's side to lead the mooring ropes. Another 8 in. by 10 in. single-drum winch is located in the windlass room forward, while an 8 in. by 10 in. winch, having two drums, is situated on the upper deck aft. One drum of the after winch is intended to take the 3½ in. mooring hawsers, while the other takes



AUXILIARY POWER SCHOONER ON LEFT, JUST PREVIOUS TO LAUNCHING.

so that they may not foul lock gates or other obstacles when the vessel is navigating narrow waterways.

The main and emergency steam steering engines are situated right aft on the main deck. Both gears consist of a 9 in.

the 4½ in. wire hawser which is attached to the stern anchor of 4,000 lbs. weight. The latter, which is also of the "Britannic" stockless type, is stowed on an inclined platform, so that it can be instantly lowered in case of emergency.



AUXILIARY POWER SCHOONER "MARGARET HANEY" BEING TOWED TO BUILDERS' WHARF AFTER LAUNCHING.



AUXILIARY POWER SCHOONER "MARGARET HANEY" TAKING THE WATER.

General Equipment

The boat outfit consists of two 22-ft. metallic lifeboats and one 18-ft. gasoline launch, for use in harbor, capable of attaining a speed of 8 miles an hour. All the boats are placed aft at the level of the deckhouse top, and are attached to davits and equipped with Huff's releasing hooks.

The vessel has two steel pole masts, one forward and one aft, for signalling purposes and to carry the running lights. Awnings are fitted over the forecastle deck and the pilot-house and at the sides of the after deck-house. Draught gauges are provided at each end of the ship, so that the draught forward and aft may be read in disturbed water or at night.

The ship is lighted throughout by electricity, the total number of lights being about 200. For providing the necessary current there are two electric generators, each having a capacity of about 10 kilowatts. The generators are sit-

uated on a flat at the after end of the main engine room. An electric indicator is placed in the pilot-house to show whether all the running lights are in order.

Propelling Machinery

The propelling machinery, which has also been constructed by the Collingwood Shipbuilding Co., is located at the after end of the vessel. Steam is generated by three single-ended cylindrical boilers of the Scotch marine type, each having a diameter of 13 ft. and a length of 11 ft. The boilers are designed for a working pressure of 185 lbs. per sq. in. and are provided with Howden's system of forced draught. From the boilers the steam passes to a single set of triple expansion reciprocating engines having cylinders 24, 40 and 66 in. diameter respectively, by 42 in. stroke. The engines are capable of developing about 2,400 I.H.P. which will drive the ship at a speed of about 13 miles per hour when loaded, and 15 miles per hour when light.

The auxiliary machinery includes one

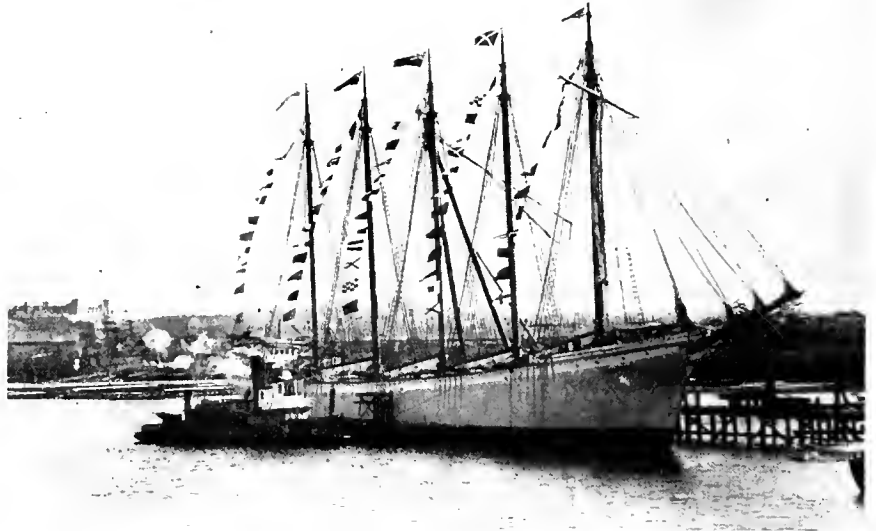

AUXILIARY POWER SCHOONER "MARGARET HANEY" READY FOR SEA.

centrifugal and two duplex ballast pumps, one sanitary pump and one deck pump, one duplex main feed pump and one duplex auxiliary feed and fire pump. The air, circulating, and bilge pumps are direct driven from the main engines. In addition to the steam pumps, hand bilge and fire pumps are provided both forward and aft.

The steamer will be sailed by Capt. S. Hill with J. Norris as chief engineer.



AUXILIARY POWERED SCHOONER "LAUREL WHALEN" LAUNCHED

GAILY bedecked, and in the presence of several thousand spectators, the auxiliary powered schooner Laurel Whalen was launched from the Cameron Genoa Mills Shipbuilders' yard, on the afternoon of March 24. Miss Marjorie L. Brewster, the young daughter of Hon. H. C. Brewster, Premier of British Columbia, although only eleven years of age, carried out her role as sponsor with charming grace, and as the vessel started, almost imperceptibly at first, on the

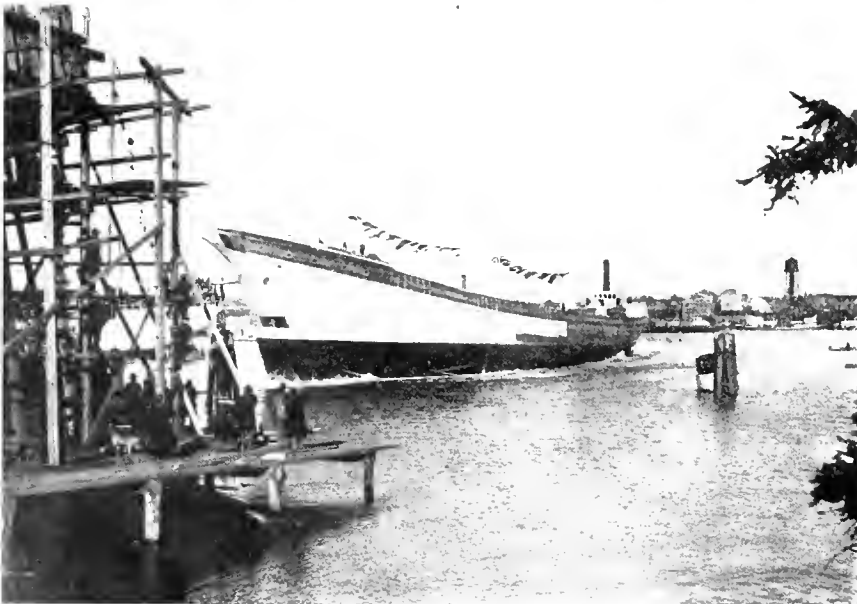

AUXILIARY POWER SCHOONER "LAUREL WHALEN" JUST AFTER SHE HAD LEFT THE WAYS.

downward course the little lady sent the beribboned bottle of champagne crashing against the bow and the Laurel Whalen officially received the name by which she will soon be known in distant ports of the world. In her arms Miss Brewster carried an immense bouquet of American Beauty roses and after the ceremony she was the recipient of a handsome present.

With the launching of the Laurel Whalen there are now four of the fleet of ten vessels ordered by the Canada West Coast Navigation Company afloat, their names being as follows in the order of their launching: Mabel Brown, Margaret Haney, Geraldine Wolvin and Laurel Whalen. The next boat to be launched will be the Jessie Norcross, named after the wife of J. W. Norcross, vice-president and general manager, Canada Steamship Lines. The vessel is building at the Wallace Shipyards, North Vancouver. There remain now on the ways of the local shipyard two more vessels, of the same class as the Margaret Haney and the Laurel Whalen, and work on these two ships will be carried on with all dispatch. The next boat to be launched will be the Esquimalt. The fourth schooner has not yet been named.

Prominent People Present

On the launching stage Premier Brewster was accompanied by other members of the Executive Council, while representatives of every public department and of the business community were present, including civic officers, railway representatives, naval officers, municipal officers, shipping and insurance representatives, the clergy, boards of trade, clubs, legal firms and others.

All four of the schooners now afloat have been chartered to the Canadian Trading Co. The Mabel Brown will load for Sydney, the Margaret Haney for Calcutta, the Geraldine Wolvin for Melbourne and the Laurel Whalen for South Africa.



TRIAL TRIP OF AUXILIARY POWERED SCHOONER "MARGARET HANEY"

WITH a number of invited guests aboard, the auxiliary schooner Margaret Haney spent the greater part of the day of April 5 in a cruise which extended from Victoria harbor out to the eastward as far as Trial Island, and following a semi-circular route, returning by way of Port Anceles, the vessel behaving splendidly throughout the entire trip. A few days later she left for Vancouver to take on a full cargo of lumber from the Rat Portage Lumber Co. mill for delivery at Bombay, India.

Capt. Whiteley piloted the Haney on her trial. Capt. G. S. LaPraik representing the owners, while included in the passenger list were H. W. Brown, manager of the Canada West Coast Navigation Co., the owners; J. O. Cameron and D. O. Cameron, of the Cameron Lumber Co., who were the first to undertake the building of ships in Victoria; Harry McDewitt of the Empire Lumber Co.; W. H. Bullock-Webster of the legal firm of

Bullock-Webster & Bass; S. Baxter, Provincial Boiler Inspector; Geo. Kirkendall, shipping master of Victoria; T. G. Mitchell, Lloyd's surveyor for British Columbia; D. Stevens; Clarence Carter, of the Carter Electric Co.; R. Dowswell, R. C. Ross, W. Cairnes Harper, E. Rochon, E. W. Hume and others.

Makes Good Speed

During the trials, the Margaret Haney made, with sail and power combined, and a breeze of about 3 Beaufort Scale, an average of ten knots per hour. Unfortunately, however, the wind was not of sufficient duration and force to warrant a satisfactory trial with sail power alone, but the management and the experts on board expressed themselves as more than satisfied with the results attained. Weather conditions were ideal for holding the trial, except for the lack of wind, and upon their return to port everybody declared that a most enjoy-

SHIPBUILDING PLANT FOR TORONTO

We are in a position to advise that steps will be taken very shortly towards the establishment of a large shipbuilding plant on Ashbridge's Bay, Toronto, the executive personnel of which we meantime may not disclose. It may, however, be stated that the men behind the project are not only well and favorably known as residents of the Queen City, but as successful business men in enterprises whose scope finds an outlet both there and in a Dominion-wide sense.

able and profitable day had been spent, having learnt something about the construction and the working of the locally-built ship.

The auxiliary powered vessels being built on the Pacific Coast are all of the Margaret Haney type, and are capable of being handled by eighteen men, including captain, two mates, three engineers, one donkeyman, two apprentices, seven seamen, cabin boy and cook. The officers' quarters are located under the poop deck and are very conveniently laid out, while the quarters for the crew are situated forward.

Oil Fuel Provision

G. Kingsland, superintending engineer for the company, laid out the engine room, tank, fuel and water arrangements and the engines were installed in the Margaret Haney under his instructions by A. T. Blythe. The fuel used is crude oil. The main fuel pumps draw fuel from any one of the six main fuel tanks and discharge into the service tanks; they can also be used for trimming purposes by discharging back into any one of the six tanks. The fuel pumps are in duplicate so that in case of any accident where one goes wrong the other can be used. The system of filters on the main fuel line is

so arranged that either of the filters may be taken out and cleaned without in any way hindering the flow of fuel to the main engines.

Propelling and Auxiliary Machinery

All the auxiliary engines on the boat, which include windlass, four winches, one fire pump, bilge pump and two fuel pumps, can be run on either steam or compressed air. The steam is furnished by a donkey boiler located under the fo'castle head, and the air by two compressors on the main engines and one auxiliary compressor driven from the electric light plant. The main engines consist of two 160 horse power Bolinder engines, from Stockholm, Sweden. The horse power is developed at 225 revolutions per minute, giving the ship a speed of approximately 8 knots under power alone.

The engines are of the two-cycle type, as is most common among semi-Deisel engines. A direct reversible mechanism consisting of a one-way clutch allows the propeller to turn free when the vessel is under sail. This means that practically all drag from the propellers will be eliminated as when the ship attains a speed of over 2 knots, the propellers will turn of their own accord. This clutch is manipulated by compressed air, and the rams used for the purpose were built in Vancouver.

Reversing Gear

The reversing gear is very simple, being controlled by one lever which automatically stops the injection of fuel from the fuel pumps and, as the engine comes to rest, injects a single jet of fuel into the cylinder as the piston is on the up-stroke. The pressure caused by this explosion brings the piston to rest and starts it on the down stroke before it reaches top centre.

The fuel consumption of the engines when developing their rated horse power of 160, is a little over eleven gallons per hour, and as the fuel tanks have a capacity of 30,000 gallons, it will be seen that the vessels have a large cruising area.

Electric light is furnished throughout the ship by a four kilowatt Canadian Westinghouse generator which is driven by an eight horse power Bolinder engine of a similar type to the main engines. This engine also drives an auxiliary air compressor which may be used when the main engines are at rest to furnish compressed air for operating either the bilge or the main fuel pumps.

Ventilation in the engine room is furnished by two skylights, located at the after end, and two ventilators, one on each side. The circulation of air from these keeps the engine room at a moderate temperature, and it is not expected that it will become excessively hot even when the ship is in a tropical climate.



Victoria, B.C.—A survey has been made of the G.T.R. Steamer Prince Rupert which is now in dry dock at Yarrows Ltd. The damage is extensive and repairs will take about two months to complete.

PROGRESS IN NEW EQUIPMENT

A Record of New and Improved Machinery and Accessories for the Machine, Pattern, Boiler and Blacksmith Shops, Planing Mill, Foundry and Power Plant

COMBINED STEAM TURBINE AND CENTRIFUGAL BOILER FEED PUMP

THE tendency towards displacement of the reciprocating boiler feed pump by the centrifugal pump furnishes a good example of the necessity resting upon manufacturers of machinery for sustained technical development. Since it must handle a comparatively small amount of water against a relatively great head, the centrifugal boiler feeder should be fitted with small diameter impellers running at high speed. It is therefore well adapted for steam turbine drive. Fig. 1 shows an early steam turbine-driven boiler feeder built in 1910 by the De Laval Steam Turbine Co. The two-stage pump has a capacity of 1,600 gals. per minute against 700 ft. head at 2,800 r.p.m., and upon test gave an efficiency of 60 per cent. The pump is entirely independent of the turbine, a coupling being interposed between the pump shaft and the turbine shaft, and it could therefore have been driven just as well by electric motor or by rope or belt as by a steam turbine.

The unit, however, realized the advantages peculiar to the centrifugal boiler feeder, viz., reliable and uninterrupted service with little, and often unskilled attention, absence of pulsation, shock, water hammer, vibration, or over pressure in pipe lines, elimination of relief valves, suitability for use with automatic boiler feed regulators acting independently at each boiler and with feed water meters, close governing, either by speed governors or by pressure governors, freedom from injury by overloading, lightness and compactness, accessibility, elimination of valves, packings, sliding sur-

sumption of oil, efficiency, and in the turbine-driven type, ability to use superheated steam or to run upon either high or low pressure steam, oil-free exhaust, and independence of the main units.

A still further development in the direction of compactness and simplicity is shown by Figs. 4 and 5, illustrating a 3,000 horse-power, two-stage centrifugal

eye of the succeeding impeller. This means of energy conversion is claimed to be superior to the use of diffusion rings as it is efficient over a wider range of delivery, and more important still, does not involve the use of small and sharp parts like diffusion blades, which are subject to rapid erosion.

The pump is hydraulically balanced and

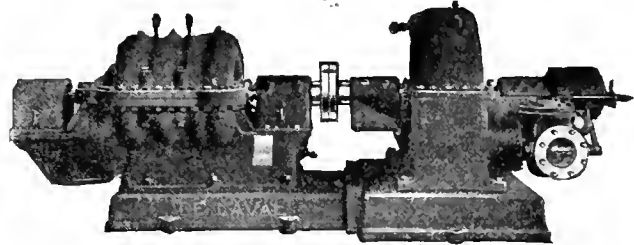

FIG. 1. DE LAVAL CENTRIFUGAL BOILER FEED PUMP COUPLED TO INDEPENDENT TURBINE.

boiler feeder combined in one casing and on one shaft with a velocity-stage steam turbine. This unit, which also has been developed by the De Laval Steam Turbine Co., weighs, it is claimed, about one-tenth as much as a duplex reciprocating pump of the same delivery and occupies only about one-eighth as much floor space and one-fifteenth as much cubical space.

The pump end contains two single-suction impellers cast from a special bronze and carefully finished to exact contours. Two impellers are used for pressures up to 200 lbs. per sq. in., and three impellers for higher pressures. Single-stage boiler feed pumps have been built, but two or three stages are preferable because of the much longer life of the impellers at slower speeds. Each impeller

only one pair of labyrinth rings surrounding the suction opening is required for each impeller except the last, which has two sets of rings. The whole back of the impeller is subjected to a pressure equal to that existing at the periphery of the impeller, the same pressure acting on the front of the impeller, except for the area of the circle enclosed by the labyrinth ring about the suction opening. The last impeller, that is the one from which the water is finally discharged, is equipped with two sets of wearing rings, one on the suction side and one on the reverse side of the web. As some water from the discharge of this impeller will leak between the wearing rings into the space back of the web, this impeller would be equally as unbalanced as the other impellers in the

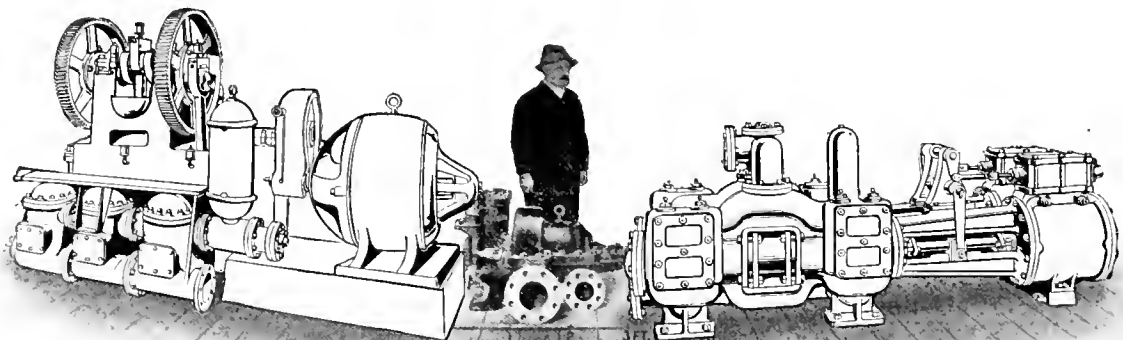

FIG. 2. COMPARATIVE CAPACITY DIAGRAM SHOWING STEAM TURBINE-DRIVEN BOILER FEED PUMP, DUPLEX STEAM PUMP, AND TRIPLEX MOTOR-DRIVEN PUMP.

faces and air chambers, small upkeep and attendance expense due to simplicity and few wearing parts, lower cost of maintenance of piping system, small con-

discharges into a volute chamber by means of which the velocity in the water as it leaves the impeller is converted into pressure before the water is led to the

pump if there were no escape for the leakage water. To provide for diminishing the pressure in this balancing space as much as may be required to

bring the whole series of impellers into balance, a leakage outlet is provided from which water can be conducted back to the suction of the first impeller.

The outlet leakage takes place between two collars, one attached to the casing and the other carried on the shaft. When

ing labyrinth rings is highly important for securing high efficiency in pumps of comparatively small delivery. With the labyrinth type of ring the leakage path is so tortuous that very little water escapes even at high heads, although ample clearance is provided to take up ex-

heater or to condenser or for low pressure steam exhausting to condenser, or the unit can be made interchangeable, thus permitting of a great degree of flexibility in plant design. Where the exhaust steam from the boiler feeder is consumed in heating feed water, the thermal efficiency of the turbine-driven boiler feeds is greater than that of a boiler feeder driven by electric motor, or even than that of the main unit itself.

The unit is in some instances fitted with a speed governor mounted upon the end of the shaft, and when running at constant speed, the head varies with the delivery, as shown by the curved characteristic in the accompanying chart. As will be seen, the rise in pressure at reduced capacity is not excessive. Ordinarily, however, a pump governor controlled by the pressure at some point in the feed line near the boilers is employed to control the speed, giving a practically uniform pressure at all deliveries, as shown by the lower and straight line in the chart. In case of failure of the pressure governor to operate, the control of the unit is automatically taken over by the speed governor.

However, to provide against any possibility of racing, an emergency governor is also fitted. This consists of a pin contained within a hole bored diametrically through the shaft. This pin is held by a spring from flying out under the influence of centrifugal force. When the speed reaches a certain point, the spring is compressed so that the pin strikes a trip, releasing another spring by which the governor valve is closed at once and completely. Racing and excessive over-pressure are therefore impossible. The normal speeds of these pumps vary from 1,800 to 3,500 r.p.m., according to pressure and capacity, and due to the heavy shafts employed are far below the critical speeds.

The bearings are of the straight, split ring-oiled type, and like other parts subject to wear, such as the pump impellers, turbine rotor labyrinth rings, and governor valves, are built to a limit-gauge basis, so that they are all interchangeable.

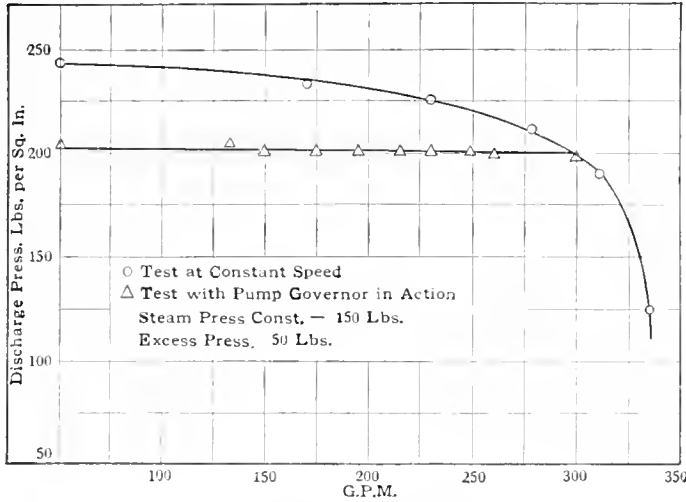

FIG. 3. HEAD DELIVERY CHARACTERISTIC OF DE LAVAL TURBINE-DRIVEN BOILER FEED PUMP UNDER CONTROL OF SPEED AND PRESSURE GOVERNORS RESPECTIVELY.

the shaft moves towards the discharge end of the pump this escape is closed off and the pressure builds up in the balancing chamber. If the shaft, on the other hand, moves toward the suction, this escape passage is opened wider, allowing the pressure in the balancing chamber to fall and at the same time the inleakage between the labyrinth wearing rings is decreased. By this means direct and positive balancing within very close limits is secured with leakage of but a small amount of water. The so-called natural balancing secured by the use of double suction impellers in a multi-stage pump is in comparison uncertain and imperfect, besides involving an extra long shaft, heavier impellers, and two pairs of wearing rings to each impeller.

pansion and contraction due to changes in temperature.

The suction end of the pump is adjacent to the turbine, and the shaft packing between the turbine and pump chambers is hence subjected to turbine exhaust pressure on one side and the suction pressure on the other. A simple packing is therefore sufficient, and in any case, any small leakage of steam in one direction or of water in the other does no harm. As the leakage space adjacent to the balancing chamber at the discharge end of the pump is connected back to the pump suction, the packing about the shaft is subjected only to suction pressure. Aside from the intermediate packing already mentioned, there is only one steam packing, which is subjected to exhaust pressure.

The steam end of the unit consists of

The labyrinth wearing rings are re-

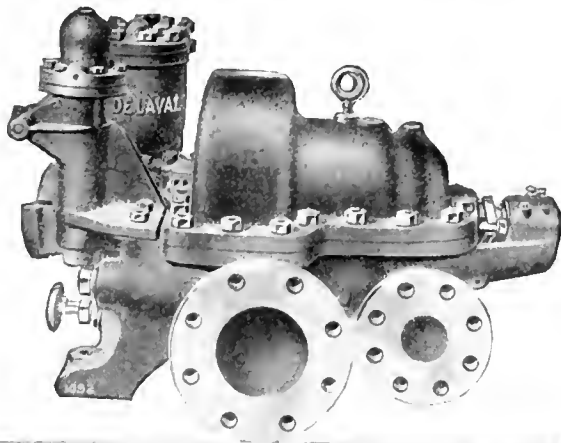

FIG. 4. DE LAVAL COMBINED TURBINE-DRIVEN BOILER FEED PUMP. CAPACITY 3,000 BOILER-HOUSE POWER.

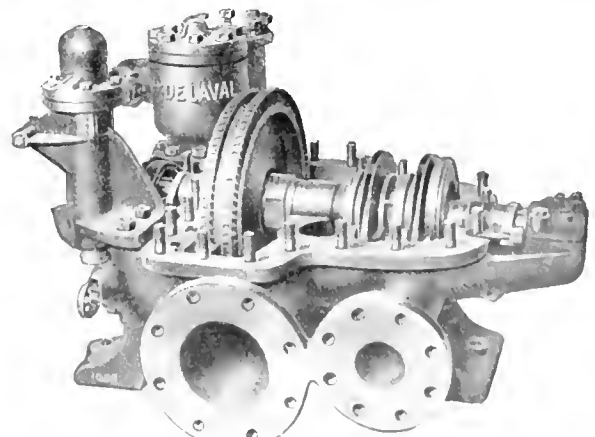

FIG. 5. DE LAVAL COMBINED TURBINE-DRIVEN BOILER FEED PUMP WITH CASING COVER REMOVED.

dily renewable, the stationary ring of each pair being held in seat in the casing and the rotating ring being screwed upon the impeller. The reduction of leakage secured by the use of intermesh-

a velocity-stage turbine with either two or three rows of moving buckets, according to the steam economy desired. The nozzles can be proportioned for either high pressure steam exhausting to feed

able. The entire rotating members and all wearing parts, with the exception of the governor valve, are accessible for inspection or removal upon lifting the casing cover and taking off the bearing caps,

all of which can be done without breaking steam or water pipe connections.

In specifying the capacity of boiler feeders, the temperature of the water to be pumped should always be stated, as the capacity is nearly 50 per cent. greater with water at 75 deg. F. than with water at 210 deg. F. For the same reason, capacity and efficiency tests of a pump should be carried out with water at the temperature at which it will be received by the pump when in actual service. The De Laval Steam Turbine Co. inform us that they are equipped to make such tests on all pumps that it builds.



TRIPLE PURPOSE RADIAL DRILLS

A NEW triple purpose radial drilling machine has been developed by the American Tool Works Co., Cincinnati, which is so designed that in addition to performing the work of a standard radial machine, will do boring operations efficiently and economically that heretofore could not be handled on a radial drill. This result is accomplished by providing a quadruple gear head affording four distinct speeds, the two lowest forming the heavy tapping and boring range, and the other two speeds being adapted for high-speed drilling and light tapping.

The lower speed range in conjunction with the eight gear box speeds offers sixteen speeds from 15 to 31 rev. per min. which are obtained through an internal gear drive on the spindle, while the high speed range consists likewise of sixteen speeds which vary from 94 to 500 rev. per min., these latter being obtained through an external gear drive which is so arranged that it is

Convenience of handling and simplicity of construction have received more than ordinary consideration. Two traversing hand wheels are fitted, one on each side of the head, and also two spindle racking levers. A conical roller-bearing is interposed between the column and bottom of the sleeve to insure easy swinging, while a radial ball-bearing at the top of the column takes all side thrust from the sleeve. The simplicity of the entire mechanism is evidenced by the fact that only 15 gears are required in the speed changing mechanism to provide for 32 spindle speeds.

In view of the increased field of applications of the machine, the question of material has received more than ordinary consideration. With the exception of a few feed gears, for which manganese bronze is employed, every gear is of steel, the pinions and clashing gears being heat-treated and hardened. All shafts in the head and gear box are made of high-grade crucible steel, while the long vertical and horizontal shafts are made of 45 point carbon special ground stock. Every cylindrical bearing in the machine is renewable, and is bushed with a high-grade of phosphor bronze.

Centralized lubrication is a prominent feature, eliminating all possibility of trouble from overlooking any one point of application. Every oil duct is brought to centralized locations on the head and cap, at which points the oil is introduced. Annular oil chambers are formed on the outside of each bushing, the flow of oil onto the shaft being through a strip of felt inserted in a lengthwise slot in the bushing, this construction insuring a continuous and uniform supply of clean oil to the bearings and preventing waste of oil before it has performed its duty.

between the mechanism and the spindle, and acts as a slipping point.

A similar device is incorporated in the elevating mechanism, so that the shock of gear engagement is completely absorbed. Automatic "knock-outs" on the elevating shaft prevent the arm from travelling beyond pre-arranged points on the column.

The cone and tumbler type of gear box has an automatic silent clutch auxiliary drive which keeps the shafts and gears running while the speed changes are being made, removing most of the shock of engagement. Provision has been made for the use of an arm support when doing heavy boring. The standard motor drives are through gear box, and direct connected.

Regular equipment includes plain box table 28 in. square, with a machined side surface 28x14 in. mounted on an extension to the base at side of column, double friction countershaft, and cone pulley drive. No wrenches are required.



HIGH-SPEED HEAVY DUTY CUTTING-OFF SAW

ABILITY to perform heavy duty work to the full extent of its capacity and at the same time possessing a sensitiveness of operation which adapts it to work of smallest size, characterizes the high-speed cutting-off saw illustrated herewith. This machine is a recently developed design by the Peerless Machine Co., Racine, Wis., the principal feature of the tool being the manner of controlling the saw guide, which is counterbalanced by the four coil springs mounted in such a way that the bearings are relieved of all strain while the tension in the springs acts so as to raise the saw frame upwards.

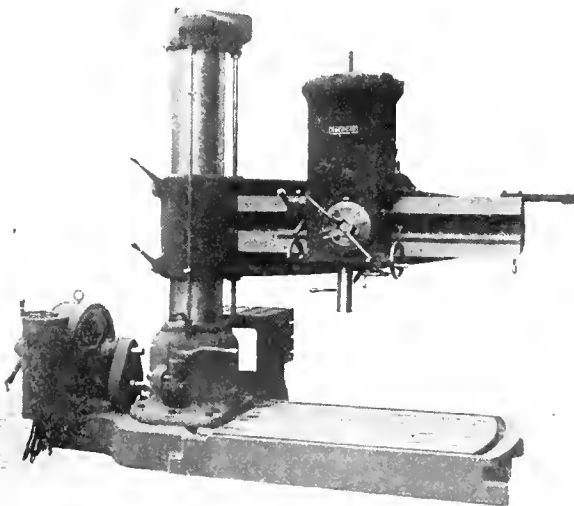

TRIPLE PURPOSE RADIAL DRILL

non-interfering with the internal drive. A striking feature of this machine is the manner in which the head mechanism is fully enclosed by a single housing which displaces the numerous gear guards usually employed and contributes greatly to increased safety in handling the machine.

Eight feeds are provided in geometrical progression from .005 to .040 in. per revolution of spindle. This mechanism is direct reading and only one dial is required for its operation. The feed mechanism is thoroughly protected against sudden shocks or excessive stress by a friction which forms the connection

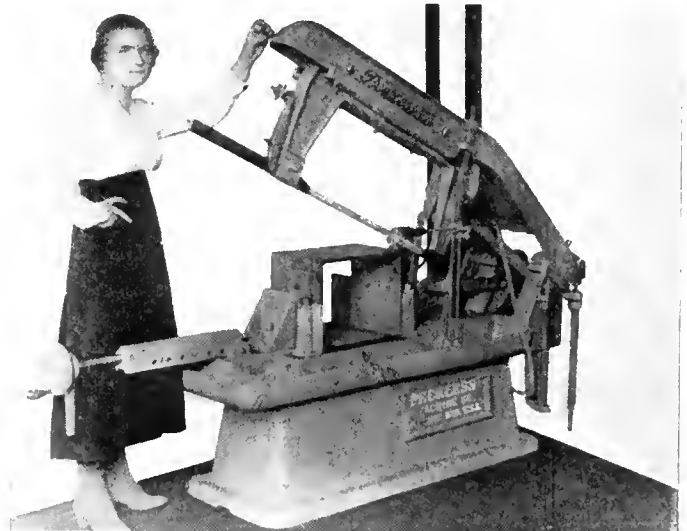

HIGH-SPEED HEAVY DUTY CUTTING-OFF SAW.

An adjustable spring-controlled feeding mechanism is so arranged that the frame cannot feed down unintentionally. Feeding of the frame down to the work is accomplished by two ratchet dogs which give a uniform feed pressure on the blade throughout the entire cut. The pressure of the feed is controlled by a

hand lever which is instantly adjustable, and the mechanism is so connected to the belt shifting lever that the feed does not engage until the belt is about three-quarters on to the tight pulley; this allows the machine to get up full speed and supply a stream of cutting compound to the blade before it comes in contact with the work. Should the machine be inadvertently started while the saw blade is above the work, it will feed down by means of the feeding mechanism until the blade comes in contact with the work, after which the feed is decreased to whatever the blade will cut.

Should the blade break, the frame feeds down to an adjustable stop when it is automatically released and returns to its upper position, the belt being simultaneously returned to the loose pulley.

The saw frame has square ways with provision for taking up wear in the slide. It is driven by a steel crankshaft of the centre crank type. The rear vise jaw swivels to allow for handling mitre work, and the front jaw is of a quick acting type, with handwheel for rapid adjustment and ratchet lever for tightening up.

A brass gear pump is located in the cabinet base for supplying cutting compound, and the table is provided with two tee-slots for holting irregular work, while a deep tray surrounds the table for catching compound and chips.

The machine illustrated has a capacity of 13x16 in. stock and weighs 1800 lbs. It can also be equipped with direct motor drive and also with 6-speed gear box.



RENNERFELT ELECTRIC ARC FURNACE

DURING the past two and a half years, or since the inception of the shell industry, the utilization of the electric furnace for the production of steel has made rapid and remarkable progress, and the knowledge acquired during this period of activity will, in all probability, open a still wider field for this process of manufacturing steel and other metals on a commercial basis for many domestic requirements.

Electric furnaces are not only finding a place in the foundries of the steel industry, but are proving themselves to be an essential factor in the evolution of this branch of engineering practice. While the principle of all electric furnaces is similar, the method adopted by the different manufacturers of applying electric current for the dissolution of metal provides a means of comparison for the various makes of furnaces. The outstanding features of the Rennerfelt electric arc furnace, illustrated herewith, are the location of the three electrodes,

electrodes, and this forces the entire radiating arc, by the resolution of forces and electro-magnetic action, down on the bath. The horizontal electrodes are about 15 inches above the bath or slag in some of the larger size furnaces, and the operating distance from tip to tip of the horizontal electrodes is usually from

of the cooling boxes is also made less. Only 1/8-inch clearance is allowed, which is just enough room to compensate for the slight irregularity in the manufacture of what are ordinarily perfectly round electrodes.

Probably the greatest advantage that can be accorded to this type of furnace

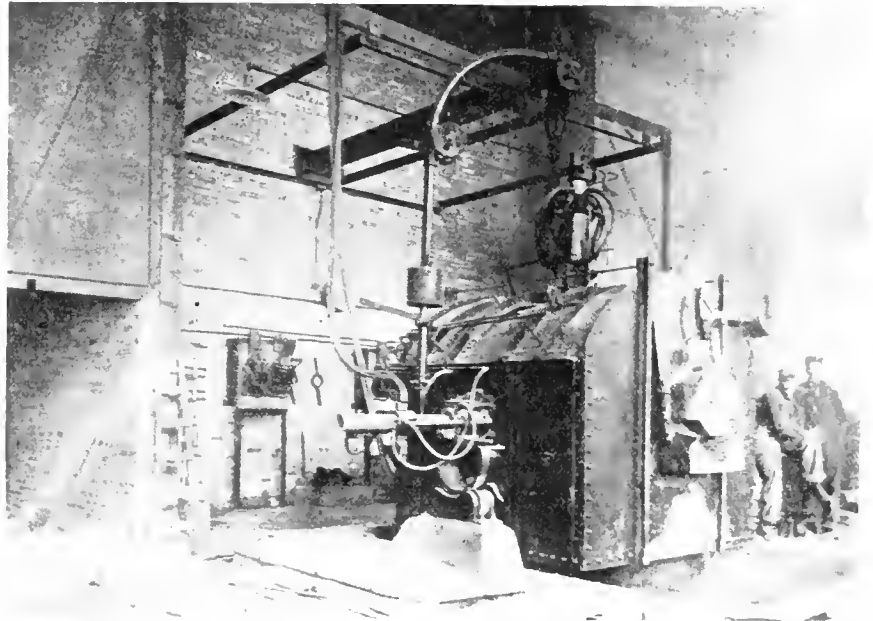

"RENNERFELT" ELECTRIC ARC FURNACE INSTALLATION.

18 to 22 inches or more. These dimensions give an idea of the size of the flame, which, striking the bath, mushrooms to the side and ends of the furnace. The heat reaching the roof is consequently very indirect, thus favoring low roof-maintenance costs.

On account of the peculiar characteristics of the Rennerfelt arc, it is very steady with hand regulation, and the furnace operation is electrically simplified to a marked degree, by avoiding all automatic electrode regulation, although motors with push button control are contemplated. As only 4 or 6 pounds of Acheson graphite are burned away per ton of cold steel scrap or pig iron, melted and treated, it is evident that the electrode regulation with such a steady arc, made between three points of stability, that is, the tips of three electrodes, is a minimum. Light metal scrap or turnings can be heaped in the furnace with the electrodes touching the charge, and yet before many minutes the free burning arc between the electrode tips has established itself. The majority of these furnaces are operating with basic bottoms; but in the case of a few, where high-class raw material is available at reasonable prices, the acid bottom has been adopted.

The wear of the electrodes seems to depend upon three things—first, the density of the current; second, the cir-

is its adaptability to the satisfactory dissolution of all kinds of metal, such as copper, bronze, red brass, nickel, aluminum, and such mixtures where zinc does not predominate, or where the percentage is low. The quiet state in which the metal is retained during the melting process is one of the chief reasons why the oxidation and volatilization is kept very low, thus preventing the escape of poisonous gases from copper charges. This may also explain in a measure why the burn-off in ordinary miscellaneous steel scrap is only about 3 per cent. in the Rennerfelt furnaces. These furnaces are being placed on the Canadian market by the firm of Hyde & Sons, 12 Bleury Street, Montreal.



Some Loan.—A Kerry peasant sued another for a loan. "It was a Kathleen Mavourneen loan, yer honor, an Paddy Kane knew it was at the time he gave it to me," said the defendant.

"A Kathleen Mavourneen loan?" said the puzzled judge. "What sort of a loan is that?"

"That's what we call one kind of loan, yer honor, down in our part of the country; it may be for years and it may be forever."



A teacher in a North of England

The MacLean Publishing Company LIMITED

(ESTABLISHED 1888)

JOHN BAYNE MACLEAN - - - - - President
H. T. HUNTER - - - - - Vice-President
H. V. TYRRELL - - - - - General Manager

PUBLISHERS OF

CANADIAN MACHINERY AND MANUFACTURING NEWS

A weekly newspaper devoted to the machinery and manufacturing interests.

PETER BAIN, M.E., Editor. B. G. NEWTON, Manager.
Associate Editors.
A. G. WEBSTER, J. M. WILSON, J. H. RODGERS.

Office of Publication, 143-153 University Avenue, Toronto, Ont.

Vol. XVII. MAY 3, 1917 No 18.

OBJECTIVE OF MUNITIONS SCRAP CONSERVATION

AS a result of the demand for munitions steel, the rolling of rails for either domestic or export purposes has now been at a standstill for many months in each of our two steel mills specially equipped for same. The need of steel rails is only less urgent than that of munitions steel, and just here there exists ample evidence that as shell requirements become less pressing, and cease ultimately, a period of more or less abnormal activity will continue to mark steel plant operation on rail production.

It may readily be taken for granted that the initiation of the big electric steel plant now under construction in Toronto for the Imperial Munitions Board was inspired with the idea of relieving one or both of our rail mills of their munitions steel burden, and while the electric steel plant referred to will not produce from the raw materials—the latter as commonly understood, in another sense, the material from which its product output will be derived, may readily be classed as essentially raw. In a word, our quite enormous tonnage of scrap shell ends, shell crop ends, shell machining turnings and borings, defective billets and forgings are going to be conserved, instead of shipped out of the country as scrap, and will be reproduced in shell billet size and quantity to conform with immediate requirement.

The needs of our railroads become daily more pressing, steel for almost any one of their departments being quite as urgent as that relative to rails. The Imperial Munitions Board is alike in intimate touch with Empire and our own specially national needs, and as we have on former occasions voiced a word of appreciation of their efforts in directing our munitions and shipbuilding industries, it seems fitting that the highly important matter of our railroad maintenance should also be mentioned as coming within the scope of their vision and activities.

THE BIG SHELL SITUATION

AN editorial in our April 19 issue gave very positive indication that 8 ins. and 9.2 ins. high explosive shell manufacture would shortly cease so far as Canadian machining plants were concerned. The capacity of Britain's National Shell Factories to more than meet the needs of our forces in the field with respect to the above named type and size projectile was given as the primary reason for shutting down of the manufacturing plants. The machine.

the all too rapid depletion of the world's merchant marine from enemy "plunger" activity was nevertheless, in large measure, the deciding factor. The supply of munitions has been fully assured for many months now, and is little likely to suffer diminution; the really crucial stage was passed quite early in the war, comparatively speaking. An equally crucial situation is, however, menacing us—that with respect to food supply and its overseas transportation, therefore, while there is assurance that the guns are being fed, there is much less certainty that those who serve the guns in the field and in the workshop may not be crippled in their effort through not only insufficiency, but positive lack of food.

Admittedly, the decision to eliminate the production of completed 8 ins. and 9.2 ins. high explosive shell in Canada is not relished by the various plants concerned, and not a little activity is being displayed by the different executives with a view to renewal of contracts whose extent will enable existing equipment being conserved until all possibility of its further need for shell making shall have vanished, and its relative usefulness shall have been at least compensated for. Naturally, the Imperial Munitions Board are far from desirous that our big shell making plants should seek to dismantle while the war is not yet won; as a matter of fact we are safe in saying that the Board is fully alive to every phase of the situation as it exists, and is earnestly endeavoring by negotiation and personal effort in the proper quarter to secure such modification of the order relative to the suspension of big shell production, as will involve the minimum of hardship to our metal-working institutions. C. B. Gordon, vice-chairman of the Board is in England in connection with big shell contract renewals, although, of course, not solely, and during the sojourn of the British diplomats on this side of the Atlantic, it can confidently be assumed that the Chairman of the Board, Mr. Flavelle, has taken prompt steps to bring the necessary pressure to bear in that quarter with the like end in view, supplementing Mr. Gordon's efforts.

CANADA'S 1917 BUDGET

IT may be said of our Finance Minister's Budget, brought before the House of Commons, Ottawa, a few days ago, that its substance is nothing more or less than an expansion of the scheme of taxation of war profits, now operative. In another section of this issue a condensed detail is given of its leading provisions.

Considered either apart from or in conjunction with the present war taxes, or an income assessment, there are other taxes which, if made immediately effective, would help to pay our war debts as we go with no other effect than checking public extravagance of which there is so much evidence.

If the tax on automobiles were increased by \$10 there would be no burden on anyone who could not well bear it. The amount would be large and could be readily collected. In fact it is a tax which might well be continued after the war and the fund used to the betterment of the national highways. The tax on theatre tickets could well be doubled. There would be no increased cost for collection. The proportions are such that the poorer classes would not be greatly affected. It is a tax which would not be a burden to judge by the crowds attending houses of entertainment. Even if these crowds were decreased there would be no great harm and the public spirit would be curbed to something more appropriate to the time. In addition to the foregoing, there are numerous other commodities in the nature of luxuries which might similarly constitute a means of increasing national funds without affecting, at the machine. by a friction which forms the connection pressure of the feed is controlled by a

INDUSTRIAL NOTABILITIES

WALTER BAKER CHAMP, secretary and treasurer, and a director of the Hamilton Bridge Works Co., Ltd., Hamilton, Ont., was born in that city, March 22, 1874, son of William S. and Sarah Emily Mitchell (Hillman) Champ.

After receiving his education in Hamilton Public Schools, Mr. Champ began his business career with the Hamilton Bridge Works Co. in 1891; was appointed treasurer of the Company 1898; secretary and treasurer, 1905; and has been a director of the Company since 1910.

Mr. Champ is a member of Hamilton Board of Trade and was president thereof



WALTER BAKER CHAMP.

during 1909. He is a member of the Canadian Manufacturers' Association, having been a member of the Executive Council from 1909-1912. Additional administrative activities include, member of Executive, Hamilton Patriotic Association; treasurer, Babies' Dispensary Guild (Incorporated) Hamilton.

On April 17, 1908, he married Jessie Coates, daughter of John Coates, Ottawa. In politics he is Conservative, and in religion, Anglican.

Mr. Champ's clubs are: Hamilton; Hamilton Jockey; Hamilton Golf and Country; Hamilton Thistle Curling (President, 1915-1916), his recreations being golf, tennis and curling.

Mr. Champ resides at 333 Caroline Street South, Hamilton.

—Photo, courtesy *British and Colonial Press*.

SELECTED MARKET QUOTATIONS

Being a record of prices current on raw and finished material entering into the manufacture of mechanical and general engineering products.

FIG IRON.

Grey forge, Pittsburgh	...\$38 95
Lake Superior, charcoal,	
Chicago	41 75
Standard low phos., Phila-	
delphia	75 00
Bessemer, Pittsburgh	42 95
Basic, Valley furnace	40 00
Montreal Toronto	
Middlesboro, No. 3	
Cleveland, No. 3	
Clarence, No. 3	
Hamilton	
Victoria	

FINISHED IRON AND STEEL.

Per lb. to Large Buyers	Cents
Iron bars, base, Toronto	4 75
Steel bars, base, Toronto	5 00
Steel bars, 2 in. to 4 in.	
base	6 00
Steel bars, 4 in. and larger	
base	7 00
iron bars, base, Montreal	4 75
Steel bars, base, Montreal	5 00
Reinforcing bars, base	5 10
Bessemer rails, heavy, at	
mill	38 00
Steel bars, Pittsburgh	3 75
Tank plates, Pittsburgh	6 00
Beams and angles, Pitts-	
burgh	4 00
Steel hoops, Pittsburgh	4 25
F.O.B. Toronto Warehouse.	
Steel bars, base	5 00
Small shapes	5 25
F.O.B. Chicago Warehouse	
Steel bars	4 25
Bars, 2 in. and up	4 40
Structural shapes	4 75
Plates	6 00

FREIGHT RATES.

Pittsburgh to Following	Points
Per 100 lbs.	
C.L.	L.C.L.
Montreal	23.1 31.5
St. John, N.B.	35.1 45.5
Halifax	35.1 45.5
Toronto	18.9 22.1
Guelph	18.9 22.1
London	18.9 22.1
Windsor	18.9 22.1
Winnipeg	64.9 85.1

METALS.

Montreal Toronto	
Lake copper	\$38 00 \$37 00
Electro copper	38 00 37 00
Castings, copper	37 00 36 00
Tin	58 50 58 00
Spelter	13 00 12 00
Lead	12 50 12 25
Antimony	27 00 36 00
Aluminium	70 00 68 00

Prices per 100 lbs.

PLATES.

Montreal Toronto	
Plates, 1/4 to 1 1/2	\$7 50 \$7 50
Heads	7 60 7 60
Tank plates, 3-16 in.	7 60 7 60

WROUGHT PIPE.

In effect April 10, 1917.	
Per 100 feet—	Black Galv.
Buttweld.	
1/8 in.	\$ 4 50 \$ 6 00
1/4 in.	4 32 6 36
3/8 in.	4 32 6 36
1/2 in.	5 61 7 18
3/4 in.	7 02 9 14
1 in.	10 37 12 52
1 1/4 in.	14 03 18 29
1 1/2 in.	16 78 21 86
2 in.	22 57 29 42
2 1/2 in.	36 27 47 09
3 in.	47 43 61 58
3 1/2 in.	58 88 75 90
4 in.	69 76 89 93
Lapweld	z z
2 in.	25 53 32 01
2 1/2 in.	38 03 48 26
3 in.	49 73 62 18

3 1/2 in.	60 72 78 66
4 in.	71 94 93 20
4 1/2 in.	83 82 108 00
5 in.	97 68 126 50
6 in.	126 70 164 50
7 in.	166 60 213 00
8 in.	175 00 223 80
8 L. in.	201 60 257 80
9 in.	241 50 308 80
10 L. in.	224 00 286 40
10 in.	288 40 368 70

Prices—Ontario, Quebec and Maritime Provinces.

WROUGHT NIPPLES.

4" and under, 60%.	
4 1/2" and larger, 55%.	
4" and under, running thread,	
40%.	
Standard couplings, 4" and under,	
50%.	
4 1/2" and larger, 30%.	

OLD MATERIAL.

Dealers' Buying prices.	
Montreal Toronto	
Copper, light	\$22 00 \$21 00
Copper, crucible	26 50 25 00
Copper, heavy	26 50 24 50
Copper wire	26 50 24 50
No. 1 machine composition	22 50 19 00
New Brass clip-pings	18 00 17 00
No. 1 brass turn-ings	16 00 16 00
Heavy Melting steel	19 00 17 00
Steel turnings	8 00 8 00
Boiler plate	18 50 10 50
Axles, wrought iron	22 00 24 00
Rails	17 00 18 00
No. 1 machine cast iron	21 00 21 00
Malleable scrap	15 00 14 00
Pipe, wrought	12 50 9 00
Heavy lead	9 00 10 00
Tea lead	7 50 7 00
Scrap zinc	9 00 10 00
Aluminium	36 00 35 00

BOLTS, NUTS AND SCREWS.

Per Cent.	
Coach and lag screws	30
Stove bolts	55
Plate washers	10
Machine bolts, 7-16 and over	10
Machine bolts, 3/8 and less.	20
Blank bolts	10
Bolt ends	10
Machine screws, fl. and rd. hd., steel	27 1/2
Machine screws, o. and fil. hd., steel	10
Machine screws, fl. and rd. hd., brass	add 20
Machine screws, o. and fil. hd., brass	add 25
Nuts, square, up to 1 in., net list.	
Nuts, hex., up to 1 in., net list.	
Copper rivets and burrs, list plus	30
Burrs only list plus	50
Iron rivets and burrs	97 1/2
Boiler rivets, base 3/4-in. and larger	\$6 65
Structural rivets, as above.	6 55
Wood screws, flat, bright.	72 1/2
Wood screws, O. & R., bright	67 1/2
Wood screws, flat, brass.	37 1/2
Wood screws, O. & R., brass	22 1/2
Wood screws, flat, bronze.	27 1/2
Wood screws, O. & R., bronze	25

MILLED PRODUCTS.

Per cent.	
Set screws	35
Sq. & Hex. Head Cap Screws	30
Rd. & Fil Head Cap Screws	30
Flat 3/8 But. Hd. Cap Screws	30
Fin. & Semi-fin. nuts up to 1 in.	25
Fin. and semi-fin. nuts, over 1 in., up to 1 1/2 in.	30
Fin. and semi-fin. nuts, over 1 1/2 in., up to 2 in.	10
Studs	20
Taper plus	40
Coupling bolts, plus	10
Plauer head bolts, without fillet	10
Plauer head bolts, with fillet	10 and 10
Plauer head bolt nuts, same as finished nuts.	
Plauer bolt washers	net
Hollow set screws, list plus	20
Collar screws	list plus 30, 10
Thumb screws	20
Thumb nuts	65
Patch bolts	add 40, 10
Cold pressed nuts to 1 1/2 in.	add \$4.50
Cold pressed nuts over 1 1/2 in.	add \$7.00

BILLETS.

Per gross ton	
Bessemer billets	\$75 00
Open-hearth billets	75 00
O.H. sheet bars	77 50
Forging billets	100 00
Wire rods	\$5 00
F.o.b. Pittsburgh.	

NAILS AND SPIKES.

Wire nails	5 00 4 95
Cut nails	5 00 5 00
Miscellaneous wire nails	60%
Pressed spikes, 5/8 diam., 100 lbs.	5 20

MISCELLANEOUS.

Solder, strictly	0 33
Solder, guaranteed	0 35
Babbitt metals	14 to 60
Soldering coppers, lb.	0 53
Putty, 100-lb. drums	4 00
White lead, pure, cwt.	16 03
Red dry lead, 100-lb. kegs, per cwt.	13 87
Glue, French medal, lb.	0 25
Tarred slaters' paper, roll	0 93
Gasoline, per gal, bulk	0 31 1/2
Benzine, per gal, bulk	0 30 1/2
Pure turpentine, single bbls., gal.	0 69
Linseed oil, raw, single bbls.	1 43
Linseed oil, boiled, single bbls.	1 43
Plaster of Paris, per bbl.	2 50
Plumbers' oakum, per cwt.	9 00
Packing, square braided	0 27
Packing, No. 1 Italian	0 32
Packing, No. 2 Italian	0 25
Lead wool, per lb.	0 15
Pure Manila rope	0 29 1/2
Transmission rope, Manila	0 37 1/2
Drilling cables, Manila	0 22 1/2

POLISHED DRILL ROD.

Discount off list, Montreal and Toronto	25%
---	-----

CARBON DRILLS AND REAMERS.

Per Cent.	
S.S. drills, wire sizes up to 52	40
S.S. drills, wire sizes, No. 53 to 80	25
Standard drills to 1 1/2 in.	40
Standard drills, over 1 1/2 in.	15
3-fluted drills, plus	10
Jobbers' and letter sizes	40
Bit stock	40
Ratebit drills	15
S.S. drills for wood	40
Wood boring brace drills	25
Electricians' bits	30
Sockets	30

Sleeve	40
Taper pin reamers	20
Drills and counterdrills	list plus 30
Bridge reamers	45
Centre reamers	10
Chucking reamers	10
Hand reamers	15

COLD ROLLED SHAFITING.

At mill	list plus 40%
At warehouse	list plus 50%
Discounts off new list. Warehouse price at Montreal and Toronto.	

IRON PIPE FITTINGS.

Canadian malleable, A, add 10%; B and C, 10%; cast iron, 35%; standard bushings, 50%; headers, 60%; flanged unions, 40%; malleable bushings, 50%; nipples, 55%; malleable lipped unions, 50.	
--	--

SHEETS.

Montreal Toronto	
Sheets, Black, No. 28	\$7 75 \$7 75
Sheets, Black, No. 10	7 10 7 50
Canada plates, dull, 52 sheets	7 00 7 00
Canada plates, all bright	8 00 8 00
Apollo brand, 10 3/4 oz. galvanized	7 25 7 25
Queen's Head, 28 B. W.G.	7 75 7 75
Flour-de-Lis, 28 B.W.	7 45 7 35
Galbal's Best, No. 28	8 25 7 50
Colborne Crown, No. 28	8 00 6 75
Premier, No. 28 U.S.	8 30 8 20
Premier, 10 3/4 oz.	8 60 8 50

PROOF COIL CHAIN.

B	
1/4 in.	\$9 45
5-16 in.	9 10
3/8 in.	8 35
7-16 in.	7 15
1/2 in.	6 95
9-16 in.	6 95
5/8 in.	6 80
3/4 in.	6 70
7/8 in.	6 55
1 inch	6 40
Extra for B.B. Chain	1 20
Extra for B.B.B. Chain	1 80

ELECTRIC WELD COIL CHAIN B.B.

1/8 in.	\$15 50
3-16 in.	11 70
1/4 in.	8 40
5-16 in.	7 40
3/8 in.	6 35
7-16 in.	6 35
1/2 in.	6 35
5/8 in.	6 35
3/4 in.	6 35

Prices per 100 lbs.

FILES AND RASPS.

Per Cent.	
Great Western, American	55
Kearney & Foot, Arcade	55
J. Barton Smith, Eagle	55
McClelland, Globe	55
Whitman & Barnes	55
Black Diamond	45
Delta Files	40, 5
Nicholson	45
Globe	55
Vuleau	55
Disston	55

COAL AND COKE.

Solvay Foundry Coke	
Connellsville Foundry Coke	
Young Steam Lump Coal	
Pittsburgh Steam Lump Coal	
Best Slack	
Net ton f.o.b. Toronto	

BOILER TUBES.

Size.	Seamless	Lap-welded
1 in.	\$24 00
1 1/4 in.	30 00
1 1/2 in.	32 00	25 00
1 3/4 in.	32 00	25 00
2 in.	35 00	26 00
2 1/2 in.	44 00	33 00
3 in.	47 00	38 00
3 1/2 in.	45 00
2 1/2 in.	59 00	48 00
4 in.	74 00	60 00

Prices per 100 feet, Montreal and Toronto.

OILS AND COMPOUNDS.

Castor oil, per lb.	27
Royalite, per gal., bulk.	16
Palatine	19
Machine oil, per gal.	26 1/2
Black oil, per gal.	13
Cylinder oil, Capital	45 1/2
Cylinder oil, Acme	36 1/2
Standard cutting compound, per lb.	6 15
Lard oil, per gal.	1 45
Union thread cutting oil antiseptic	68
Acme cutting oil, antiseptic	37 1/2
Imperial quenching oil	39 1/2
Petroleum fuel oil	11 1/4

BELTING—NO. 1 OAK TANNED.

Extra heavy, single and double	30-5%
Standard	40%
Cut leather lacing, No. 1	1 60
Leather in sides	1 35

TAPES.

Chesterman Metallic, 50 ft.	\$2 00
Lufkin Metallic, 603, 50 ft.	2 00
Admiral Steel Tape, 50 ft.	2 75
Admiral Steel Tape, 100 ft.	4 45
Major Jun. Steel Tape, 50 ft.	3 50
Rival Steel Tape, 50 ft.	2 75
Rival Steel Tape, 100 ft.	4 45
Reliable Jun. Steel Tape, 50 ft.	3 50

WASTE.

White	Cents per lb.
XXX Extra	20
Peerless	20
Grand	19
Superior	19
X L C R	18
Atlas	18
X Empire	18
Ideal	17
X press	16

COLORED.

Lion	14 1/2
Standard	13
No. 1	13
Popular	11 3/4
Keen	10 1/2

WOOL PACKING.

Arrow	25
Axle	20
Anvil	15
Anchor	11

WASHED WIPERS.

Select White	12
Mixed colored	10
Dark colored	09

This list subject to trade discount for quantity.

RUBBER BELTING.

Standard	40%
Best grades	20%

ANODES.

Nickel	50 to 54
Cobalt	1.75 to 2.00
Copper	.44 to .46
Tin	.49 to .55
Zinc	.53 to .25

Prices Per Lb.

COPPER SHEETS.

	Montreal	Toronto
Bars, 1/2 to 2 in.	55 00	53 00
Plain sheets, 14 oz., 14x28 in., 14x60 in.	55 00	53 50
Copper sheet, tinned, 14x60, 14 oz.	60 00	54 25
Copper sheet, plain, 14x60 base.	64 00	60 00
Braziers', in sheets, 6x4 base	55 00	52 00

BRASS.

Brass rods, base 1/2 in to 1 in rd.	0 55
Brass sheets, 8 in. wide, 20 oz.	0 60
Brass tubing, seamless.	0 57
Copper tubing, seamless.	0 58

PLATING SUPPLIES.

Polishing wheels, felt.	2 10
Polishing wheels, bull-neck	1 35
Emery in kegs, American	06
Pumice, ground	04
Emery glue	15 to 20
Tripoli composition	04 to 06
Crocus composition	07 to 08
Emery composition	08 to 09
Rouge, silver	35 to 50
Rouge, powder	30 to 35

Prices Per Lb.

LEAD SHEETS.

	Montreal	Toronto
Sheets, 3 lbs. sq. ft.	\$16 00	\$16 00

Sheets, 3 1/2 lbs. sq. ft.	16 00	16 00
Sheets, 4 to 6 lbs. sq. ft.	15 50	15 50
Cut sheets, 1/2c per lb. extra.		
Cut sheets to size, 1c per lb. extra.		

PLATING CHEMICALS.

Acid, boracic	\$.15
Acid, hydrochloric	.05
Acid, hydrofluoric	.14 1/2
Acid, nitric	.10
Acid, sulphuric	.05
Ammonia, aqua	.08
Ammonium carbonate	.15
Ammonium chloride	.11
Ammonium hydrosulphuret	.40
Ammonium sulphate	.07
Arsenic, white	.12
Copper, carbonate, anhy.	.35
Copper, sulphate	.17
Cobalt sulphate	.70
Iron perchloride	.20
Lead acetate	.16
Nickel ammonium sulphate	.12
Nickel carbonate	.35
Nickel sulphate	.15
Potassium carbonate	.75
Potassium sulphide (substitute)	.20
Silver chloride (per oz.)	.65
Silver nitrate (per oz.)	.55
Sodium bisulphite	.10
Sodium carbonate crystals	.85
Sodium cyanide, 127-130%	.41
Sodium hydrate	.04
Sodium hyposulphite, per 100 lbs.	5.00
Sodium phosphate	.14
Tin chloride	.60
Zinc chloride	.60
Zinc sulphate	.09

Prices Per Lb. Unless Otherwise Stated.

The General Market Condition and Tendency

THE industrial situation, while favorable in regard to volume of business, is not so satisfactory in other respects. There is still a shortage of many lines of raw material, and the freight situation is not as it should be. There is still considerable congestion in the railway yards, and as a result deliveries are delayed. The coal situation is also causing considerable uneasiness owing to shortage of supplies and continued high prices. The advance in miners' wages and increase in cost of transportation will result in higher prices for the consumer. The situation in the steel market in the United States is becoming more settled and prices continue to advance. The demand for steel products is steadily increasing in spite of the abnormally high prices, and there is no sign of any decline in either respect; in fact, indications point to further advances and increases in volume of tonnage. The pig-iron situation is unchanged. Domestic iron is still off the market, and quotations therefore are unobtainable. Prices of copper and brass scrap have declined in sympathy with the virgin metal market. Steel and cast iron scrap on the other hand are firm and in good demand. The non-ferrous metal markets are unsettled on account of the uncertainty prevailing as to the requirements of the United States Government and fixing of prices. Copper and spelter are weaker and have declined, but tin is stronger and higher. The machine tool market is fairly active, but deliveries continue slow except on lathes. Prices continue to advance, affecting high-speed drilling machines and millers.

Montreal, Que., April 30, 1917.—Industrial and commercial interests are at present closely watching developments in the United States. That the general situation will experience some change is admitted, but to what extent, the trade here is still in doubt. The easing off in the production of the heavier shells has resulted in the return of some of these

plants to pre-war activity, and the domestic efforts of manufacturers are again coming to the fore. Inland marine is becoming more active and shipping interests are preparing for the season's work; river buoys are being rapidly placed in position and within a few weeks summer activity is expected to be resumed. The steel industry continues

to hold the center of the stage and is featured by further advances in many lines. Owing to the preparations now going on in the States the general industrial is rather unsettled but without seriously affecting the strong tone of the market.

Pig Iron

While production proceeds at very high pressure, the market itself has had a relatively quiet week respecting the usual advances, but this temporary lull may be followed shortly by further climbing in price quotations. The advance orders on pig iron at all furnaces retain this market in a remarkably firm position and even first half 1918 positions are being largely filled. Prices on Chicago iron have been advanced approximately \$2 per ton, but other grades have had a week's rest. The week's advance on composite pig iron is about 30 cents per ton. The local situation is practically unchanged, Canadian iron still being an absent feature in market quotations.

Steel

If such a condition is possible the steel situation is entering another phase of additional activity, that of supplying the requirements of the United States government. This demand is gradually assuming large proportions but it is not definitely known at what price this business is being placed. The delivery of this material will of course require some calculation by the producing mills, owing to the filled up condition of the various branches of the steel industry. While the Canadian situation has experienced

no serious effect as yet, there is a pronounced increase in the difficulty in obtaining delivery on certain classes of steel products. The increasing pressure that is being placed upon the mills and the heavy demand for future positions is reflected in the advances that are constantly being quoted for all grades of steel. The inability to fill the requirements of the sheet trade has resulted in sharp advances at different times in the price of sheet bars. The Pittsburgh quotation on sheet bars this week is \$85 per ton, an advance on the week of \$5 per ton. The enormous call for forging billets has resulted in still higher prices, the most recent advance of \$20 per ton raising the current quotation to \$110. The Pittsburgh price on wire rods has again been advanced, this week's quotation of \$95 representing an advance of \$5 per ton. Railroads are showing special interest in far future requirements and considerable business is being placed for 1919 delivery. Pittsburgh quotations on both light and heavy rails have been advanced \$5 per ton, the prevailing price being \$61 and \$62 respectively. The Chicago price on iron and steel bars have been advanced \$5 per ton. Local conditions are unchanged but dealers here are anticipating advances on certain lines.

Metals

Little change is noted in the general conditions. The American situation is still influencing the market and until the policy of the government is definitely announced the trade will be rather unsettled. Copper continues to fall off owing to the lack of any heavy buying movement. Tin is the feature this week, having advanced three cents on the New York market. Spelter is stronger on prospective buying. Lead is very firm with independents asking increased prices. Antimony and aluminum are both steady on fair demand.

Copper.—The market is still featured by the unsettled conditions that have prevailed during the past six weeks and prices continue to decline. Prospect of further heavy buying by the American Government has again created something of a sensation in producing circles and it appears doubtful whether additional orders will be considered at the original low figure. While the general tendency in the open market is toward lower levels, the irregularity of existing conditions does not warrant a prediction as to early future conditions. Copper may go still lower but active buying would steady and also strengthen the market. London continues to weaken and New York quotations are easier than last week: prices quoted being 31c for lake and electro, and 27½c for castings. On a slightly better demand the market here has advanced one cent during the week, the prices quoted being 38c for lake and electro, and 37c for castings.

Tin.—Considerable interest is being shown in the tin situation and activity has increased. The possibility that freer permits will characterize the shipment of tin seems to have developed a special

dealers' movement on the part of British buyers and a stronger market has resulted. The recent entrance of the United States into the war has developed quite a complicated situation, owing to the fact that quantities of tin that were being held by German interests are coming on the market, but through fear of having to make explanations the trade is somewhat reluctant about buying this metal. The ever present risk of loss in transport is one of the features of the existing strong market. During the week London has made quite a jump in price quotations and the same has happened in New York; the advance on the latter being 3c per lb. New York is now asking 58¾c per lb. Locally, the market has advanced 2c, the quotation being 58½c per lb.

Spelter.—The dullness that has prevailed in this metal has apparently been halted and a stronger tone has followed recent activity. This appears to have been started when it was reported that heavy additional buying of copper would probably be made by the American Government. This possibility has increased the confidence of the trade and the demand for supply is becoming heavier. The producers are showing the same anxiety as last week and are not so eager to sell. New York's quotation of 9¾c shows an advance of ½c per lb. A stronger tone has developed on the market here and dealers are asking 13 cents, an advance of ½c per lb.

Lead.—This metal continues to maintain its firm position in spite of the fact that the demand has shown some slight falling off, but the producers are showing no concern owing to their heavy bookings for early future requirements. The trust price continues to be quoted at 9c, but some of the independents are asking as high as 10c, this being a ¼c advance over last week. Local dealers continue to quote 12½c on a steady market.

Antimony.—The market has been quiet for spot metal but futures are fairly active. New York is quoting 33½c, a decline on the week of ½c per lb. The local market is firm at 27c per lb.

Machine Tools and Supplies

While no definite developments of great activity have taken place in the machine tool circles, the business reported this week is undoubtedly an improvement over that of the past few weeks. The demands for shell equipment are not heavy, orders being confined to single tools for replacements. However, the improvement that has been shown in other lines is a very encouraging factor in connection with the future of machine tool activity. The situation in the States is still unsettled owing to the developments that are continually taking place. Machine tool builders are now in a position to make very good delivery on all classes of tools. Better conditions are evident in the supply market but prices are well maintained.

Scrap

Conditions in the scrap market are

comparatively unchanged, prices continuing to fluctuate but with very little variation. The situation in the pig iron market has experienced a quiet week and this has apparently influenced the trade in old metal. With the exception of tin scraps the general quotations on the New York market shows a downward tendency. Local dealers continue to quote last week's prices on a steady and firm market.

Toronto, Ont., May 5.—The new tax on war profits, while more drastic than was expected, has been received philosophically in business circles, and manufacturers are to be commended for the spirit in which they have accepted the taxation. There are not many industrial concerns who will be seriously affected, and the arrangement of the schedule is such that the heavy assessment falls largely on those who are able to pay. General business conditions show no important change, although the scarcity of raw materials continues to handicap manufacturers and is restricting production. The coal situation is perhaps the most serious, for, not only is there a scarcity, but prices are going up, notwithstanding the season of the year when coal is usually cheaper. The outlook for next winter is not at all hopeful, unless some drastic steps are taken this summer to prevent another famine. In any event, it seems that high prices are inevitable, owing to increase in miners' wages and higher cost of transportation.

Steel

Recent developments in the steel market seem to indicate that prices will continue to advance indefinitely. The fixing of prices on steel products for the American Government has not caused any cessation in the upward movement; in fact the tendency is all the other way now that Government's purchases of steel are becoming more clearly defined. The expectation that the Government will ultimately require considerable tonnages of steel at a time when the mills are in a sold-up condition is giving a fresh impetus to the market and forcing prices up. Generally speaking, the extraordinary high prices on steel products are not curtailing the demand as much as might be expected, due principally to the fact that a large proportion of the tonnage is required, either directly or indirectly, for war purposes. Consumers who can wait for their material are staying out of the market until conditions become more favorable, both as to price and delivery. In regard to deliveries, the situation is becoming worse, especially on steel imported from the States, where congestion at the mills is getting more acute as the demand becomes more insistent. The Canadian mills have all the business they can take care of for several months, and as practically their entire output is bespoken for the Imperial Munitions Board, steel for ordinary purposes is very scarce. Although price changes are not so numerous this week, it is no indication of a weakness in the

market. Further advances are looked for in the near future, which will affect black sheets, plate, wire products, and possibly bolts and nuts, chain, and tubes. Ship plates have recently sold at 10c base, Pittsburgh. Although business has been done at a lower figure, it is an indication of what may develop over here. Smooth steel wire recently advanced to 6c base for Nos. 0 to 9 gauge, which will doubtless be reflected in prices of wire products. Quotations on hoops and bands are nominal, as most manufacturers have withdrawn from the market until Nov. 1. Bolt and nut prices advanced 10 per cent. in the States, which may result in higher prices here.

Prices of black sheets continue to advance, and the demand in the primary market is getting heavier. The latest advance on sheets is equivalent to \$10 per ton, which brings No. 28 gauge to \$7.75, and No. 10 to \$7.50 per 100 lbs. The United States War Department has purchased a large tonnage of sheets at what is practically the market price. In view of further Government requirements, sheet makers have practically withdrawn from the market. Prices of galvanized sheets have not advanced, but may do so in the near future, although costs are getting almost prohibitive for consumers.

Government requirements in the United States feature the steel market there, and are helping materially to force prices up. Prices of finished steel are advancing, bars being now quoted at 3.50c, and structural shapes 4c, Pittsburgh. Sheet bars have been quoted at \$82.50 mill to domestic consumers, while it is reported that 1,000 tons of open-hearth sheet bars have been sold to Canadian interests at \$90 mill. Structural shapes, Chicago warehouse, are now quoted at 4.75c. Iron bars have advanced to 3.75c Pittsburgh.

Pig Iron

The situation in the pig iron market remains unchanged. No prices on domestic iron are obtainable, and available supplies are light. At Buffalo practically the same prices as prevailed last week are still current, ranging from \$42 to \$45, according to the ability of the furnace to supply material, and without much difference as to grade.

Scrap

The scrap market is weaker for red and yellow metals, but firmer as regards heavy melting and similar materials. Copper prices have declined practically 2½c, and brass 1½c. Heavy melting is up 1c, No. 1 machinery cast iron 1c, and malleable scrap 3c. Steel turnings have recovered from the slump last week, and are now quoted at \$8. A market for this material will open up probably in July, when the electric furnace plant at Ashbridge's Bay starts operating. In the meantime supplies will accumulate.

Machine Tools

Business generally is on the quiet side, although there has been a fairly good inquiry for radial drills, punches, shears and similar machinery. Tool room equipment continues in good demand, but deliveries are backward. Developments in the States are being followed with in-

terest by local machinery houses, as it is not yet clear what effect the United States participation in the war will have on the trade in that country. Prices of machine tools in the United States are still going up, principally by reason of the increase in cost of pig iron. Some makers of milling machines have announced another advance of 10 per cent. on their product, while others have raised their prices 20 per cent. on high-speed drilling machines.

Supplies

Prices of machine shop supplies continue firm with advances on some lines. A sharp advance of 75c has been made on white lead in oil, bringing the price up to \$15.75 per 100 lbs. in ton lots. This is a phenomenal price, and is due to the high cost of pig lead and linseed oil. Gasoline is firm and unchanged, but fuel oil is down to 11¼c in gallon lots. Plumbers' oakum has advanced to 9c per lb.

Metals

Considerable activity has developed in the metal markets, being featured by declines in copper and spelter, and an advance in tin. The market in New York has been unsettled owing to the uncertainty as to the U. S. Government's requirements for war purposes, and the low prices originally fixed on copper. More recently the price of copper to the

present limitations on imports and higher cost of freight and insurance. There is also some fear of a scarcity of tin on account of the growing demand. Tin has advanced 2c, and is now quoted at 58c per pound.

Spelter.—The possibility of a low price being fixed on Government purchases has unsettled the market in New York. Early in the week it was reported that the price of spelter had been fixed at 5.85c, but this was later denied. Spelter has declined 1c locally, and is now quoted at 12c per pound.

Lead.—The market continues very firm on good demand. The position of lead is strong, and the expectation of increase in demand is tending to advance prices. Local quotation unchanged at 12¼c per pound.

Antimony.—The demand for spot antimony has fallen off, but futures are more active. The market is strong and prices continue nominal at 36c per pound.

Aluminum.—The situation is unchanged, although an increase in demand is anticipated. Local quotations are unchanged at 68c per pound.

Sydney, N.S., April 27.—The coal production in Nova Scotia is resting at the diminished level of the past six months, no further noticeable decline having taken place. The Dominion Coal Co. output for April will be about 330,000 tons as compared with 380,000 tons last April. For the first four months of the year the aggregate production shows a decline when compared with the first four months of 1916 of 210,000 tons.

Labour matters continue unsettled. A Commission has been appointed by the Minister of Labour to enquire into the question of wages as between the Dominion Coal Co., and its Glace Bay employees. The Commission consists of Dr. Forrest, ex-president of Dalhousie University, Judge Chisholm, of the Nova Scotia Bench, and John T. Joy, a member of the Workmen's Compensation Board of Nova Scotia. The personnel of the Commission is excellent. It is expected that in addition to the consideration of the wage question, the Commission will pay some attention to the disputed questions regarding the miners' unions.

Considerable activity is noticeable in all the coalfields in the opening up of abandoned collieries, and the development of easily accessible coal areas. This is a reflex of high prices for coal, but it can have no appreciable effect on the production of coal, because of the irremovable restriction of the shortage of miners. It may cause an increase in the production of smaller mining companies, but it will cause a corresponding, or probably greater decrease in the production of the large coal companies, because the workmen obtained will be taken from the large concerns, and will be attracted by less onerous working conditions, principally in the matter of the walk to work.

For the first time since somewhere in 1913, there are signs of capital expenditure at the collieries. The Domin-

**CANADIAN GOVERNMENT
PURCHASING COMMISSION**

The following gentlemen constitute the Commission appointed to make all purchases under the Dominion \$100,000,000 war appropriation:—George F. Galt, Winnipeg; Hormidas Laporte, Montreal; A. E. Kemp, Toronto. Thomas Hilliard is secretary, and the Commission headquarters are at Ottawa.

Government was raised to 25c, which helped to improve the situation. The expectation of a low price being fixed on spelter has unsettled the market for this metal. Tin has advanced, following a higher price in London. Lead continues very firm, but is unchanged in the meantime. Antimony is in good demand, although quotations continue nominal. Aluminum is unchanged.

Copper.—The market is very irregular and prices have declined, but are still nominal. The knowledge that the U. S. Government's requirements for copper are to be heavy, and that a 25c price has been fixed, and that the Allies will soon be in the market is having much to do in strengthening the position of copper. Notwithstanding this and the continued heavy demand, it is likely that prices will decline further. Local quotations have declined 2c, and are as follows: Lake and electrolytic 37c, and castings 36c per pound.

Tin.—The market is stronger and higher both in London and New York. The advance in New York is due to the

Enlarged Canadian Trade Intelligence Service

Under the arrangement made by the Minister of Trade and Commerce with Sir Edward Grey in July, 1912, the Department of Trade and Commerce, Ottawa, is able to present the following list of the more important British Consulates whose officers have been instructed by the Foreign Office to answer inquiries from and give information to Canadians who wish to consult them in reference to trade matters.

BRASIL—Bahia, British Consul. Rio de Janeiro, British Consul General.	NETHERLANDS—Amsterdam, British Consul.
CHILE — Valparaiso, British Consul General.	PANAMA—Colon, British Consul. Panama, British Vice-Consul.
COLOMBIA — Bogota, British Consul General.	PERU—Lima, British Vice-Consul.
ECUADOR—Quito, British Consul General. Guayaquil, British Consul.	PORTUGAL—Lisbon, British Consul.
EGYPT — Alexandria, British Consul General.	RUSSIA—Moscow, British Consul General. Petrograd, British Consul. Vladivostok, British Consul. Odessa, British Consul General.
FRANCE—Havre, British Consul General. Marseilles, British Consul General.	SPAIN—Barcelona, British Consul General. Madrid, British Consul.
INDIA—Calcutta, Director General of Commercial Intelligence.	SWEDEN—Stockholm, British Consul.
ITALY—Genoa, British Consul General. Milan, British Consul.	SWITZERLAND—Geneva, British Consul.
MEXICO—Mexico, British Consul General.	URUGUAY—Monte Video, British Vice-Consul.
	VENEZUELA — Caracas, British Vice-Consul.

Canadian Commercial Intelligence Service

The Department of Trade and Commerce invites correspondence from Canadian exporters or importers upon all trade matters. Canadian Trade Commissioners and Commercial Agents should be kept supplied with catalogues, price lists, discount rates, etc., and the names and addresses of trade representatives by Canadian exporters. Catalogues should state whether prices are at factory point, f.o.b. at port of shipment, or, which is preferable, c.i.f. at foreign port.

CANADIAN TRADE COMMISSIONERS.

ARGENTINE REPUBLIC—E. S. Webb, Acting Canadian Trade Commissioner, Reconquista, No. 46, Buenos Aires. Cable address, Canadian.
AUSTRALIA—D. H. Ross, Stock Exchange Building, Melbourne. Cable address, Canadian.
BRITISH WEST INDIES—E. H. S. Flood, Bridgetown, Barbadoes, agent also for the Bermudas and British Guiana. Cable address, Canadian.
CHINA—J. W. Ross, 13 Nanking Road, Shanghai. Cable address, Canada.
CUBA—A. T. Quilez, Acting Canadian Trade Commissioner, Luján del Comercio, Apartado 1290, Havana. Cable address, Cantracom.
FRANCE—Phillipe Roy, Commissioner General, 17 and 19 Boulevard des Capucines, Paris. Cable address, Stadacona.
JAPAN—E. F. Crowe, Acting Canadian Trade Commissioner, P. O. Box 109, Yokohama. Cable address, Canadian.
HOLLAND—P. H. Geleerd, Acting Canadian Trade Commissioner, Zuidblaak, 26, Rotterdam. Cable address, Watermill.
RUSSIA—C. F. Just, Canadian Government Commercial Agent, Alexandriiskaia, Plosh 9, Petrograd. L. D. Wilgress, Canadian Government Commercial Agent, Bakhgolza Ulitza No. 4, Omsk, Siberia.
NEWFOUNDLAND—W. B. Nicholson, Bank of Montreal Building, Water Street, St. John's. Cable address, Canadian.
NEW ZEALAND—W. A. Beddoe, Union Buildings, Customs Street, Auckland. Cable address, Canadian.
SOUTH AFRICA—W. J. Egan, Norwich Union Buildings, Cape Town. Cable address, Cantracom.
UNITED KINGDOM—Harrison Watson, Sub-division E.C. 2, 73 Basinghall Street, London, E.C., England. Cable address, Sleighing, London. N. D. Johnston, Sun Building, Clare Street, Bristol. Cable address, Canadian. J. E. Ray, Central House, Birmingham. Cable address, Canadian. J. Forsyth Smith, 31 North John Street, Liverpool. Cable address, Cantracom. F. A. C. Bickerdike, 4 St. Ann's Square, Manchester. Cable address, Cantracom. J. Forsyth Smith, Acting Canadian Trade Commissioner, 87 Union Street, Glasgow, Scotland. Cable address, Cantracom.

CANADIAN COMMERCIAL AGENTS

AUSTRALIA—E. Millin, Royal Exchange Building, Sydney, N.S.W.
BRITISH WEST INDIES—Edgar Tripp, Port of Spain, Trinidad. Cable address, Canadian. R. H. Curry, Nassau, Bahamas.
NORWAY AND DENMARK—C. E. Sontum Grubbegd No. 4, Christiania, Norway. Cable address, Sontums.
SPAIN—J. F. Roberts, Care British Consulate General, Barcelona.

CANADIAN HIGH COMMISSIONER'S OFFICE

UNITED KINGDOM—W. L. Griffith, Secretary, 17 Victoria Street, London, S.W., England. Cable address, Dominion, London.

ion Coal Co. is largely increasing the production of electricity at its Dominion No. 2 Power House by the installation of a 1,500-kilowatt turbo-generator, purchased second-hand. The installation of second-hand machinery is being forced on companies by the impossibility of getting early delivery of new machinery, particularly electrical machinery.

The work of excavation for new coke-ovens at the Dominion Iron & Steel Co.'s plant has commenced.



CANADIAN RAILWAYS MAKE NEW RECORDS.

THE annual report of the Comptroller of Railway Statistics, Mr. J. L. Payne, tabled in the House of Commons, Ottawa, April 23, shows that the railways of Canada established new high records in regard to practically all branches of the transportation service during the statistical year ending with June last. Gross earnings amounted to \$263,527,157, as compared with \$199,843,072 in 1915. Operating expenses last year totalled \$180,542,259, as compared with \$147,731,099 for the preceding year. Net earnings last year totalled nearly eighty-three millions, as compared with fifty-two millions in 1915.

The total operating railway mileage at the end of June last is given as 37,434 miles, which included 1,852 miles of new line added during the year, but did not take into account 3,150 miles additional which was officially classed as being "under construction," although a considerable proportion of this was actually under operation. In addition to the main line track, there are 8,396 miles of yard track and sidings, and 2,489 miles of second line track, thus bringing the total of all tracks up to 48,319 miles.

Capitalization and Aid

The railway capitalization, including capital liability on lines under construction, has now reached an aggregate of \$1,975,358,919, not including Government owned and operated lines, adding a mileage of 4,178 and a capital cost of \$306,053,937. During 1916 there was an addition to railway capitalization of \$18,066,886, made up of \$488,487 in stocks and \$17,598,499 in bonds.

The total cash aid to railways at the end of June last by the Dominion, the Provinces and municipalities, amounted to \$240,062,359. Land grants totalled 43,983,952 acres, while Dominion and Provincial bond guarantees totalled \$417,612,941.



The Bawden Machine Co., of Toronto, recently incorporated a subsidiary company called the Bawden Pump Co., for the manufacture of centrifugal and steam pumps for waterworks, sewage, filtration and industrial purposes. They will also make valves and hydrants. The Bawden Machine Co. have been manufacturing steam pumps for some years, but have decided to develop the scope of their business.

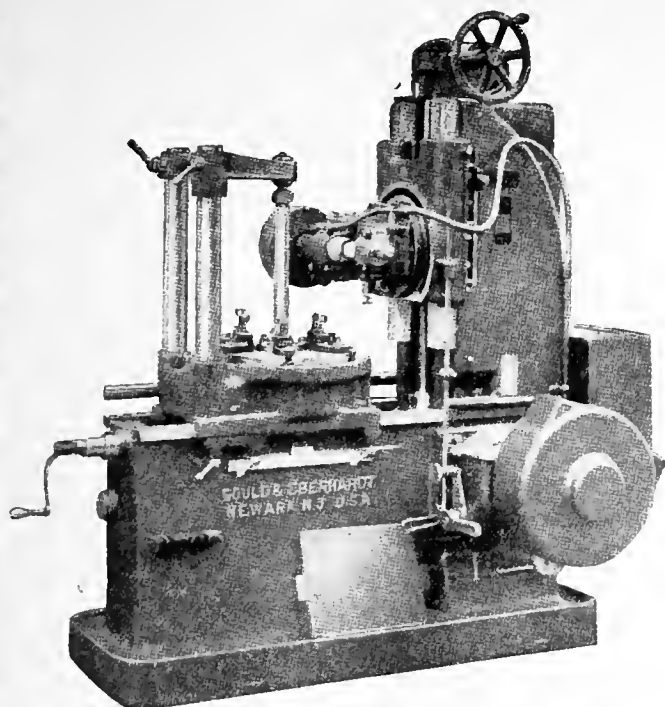

Gould & Eberhardt GEAR HOBBERS

are

Automatic therefore Economical

If you cut gears in quantities they can be cut with advantage on G. & E. Gear Cutting Machinery.

For gears up to 120" dia.

Catalog describing full line of Gear-cutting, Hobbing and Rack-cutting machines on request.

Write for prices and deliveries

The A. R. Williams Machinery Company, Limited

ST. JOHN, N.B.
WINNIPEG, VANCOUVER

"If It's Machinery, Write Williams"

64 Front Street West
TORONTO

Rapid and Perfect Duplication That is the Mission of the Geometric Threading Machine

From 1/8-in. pipe thread to 1-in. diameter is the usual range of the machine, but where fine pitch threads are to be cut on larger diameters, it can be fitted with a die head that will take care of the work

The Geometric Threading Machine is not the usual bolt threader, but a machine for producing accurate work in quantity—work that cannot be done economically in any other way, and gives threads as true and clean as can be produced on any screw machine.

Get acquainted with the machine by sending for our Threading Machine Booklet.

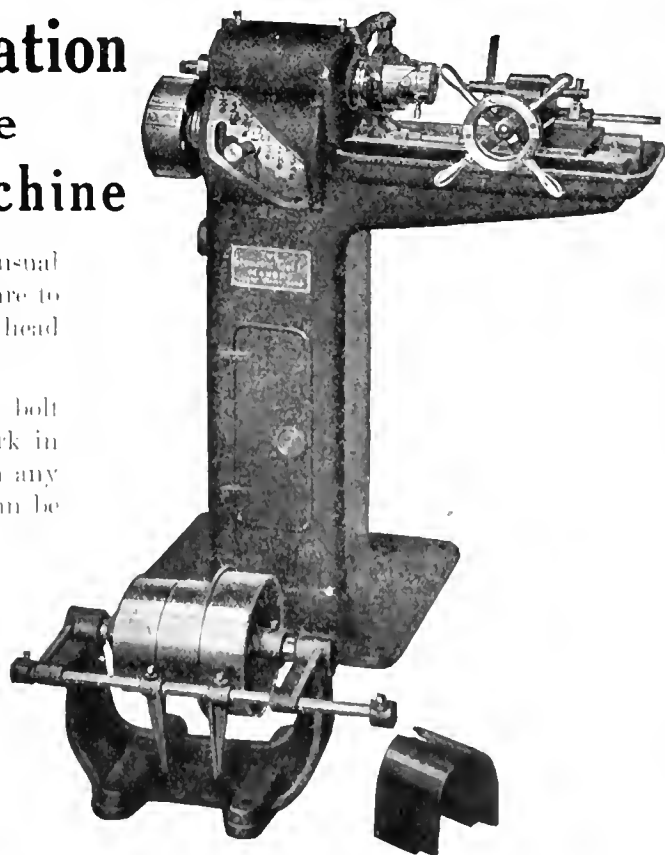

The Geometric Tool Company New Haven, Conn., U.S.A.

Canadian Agents: Williams & Wilson, Ltd., Montreal: The A. R. Williams Machinery Co., Ltd., Toronto, Winnipeg and St. John, N.B.

If any advertisement interests you, tear it out now and place with letters to be answered.

INDUSTRIAL ^A_N^D CONSTRUCTION NEWS

Establishment or Enlargement of Factories, Mills, Power Plants, Etc.; Construction of Railways, Bridges, Etc.; Municipal Undertakings; Mining News

ENGINEERING

Perth, Ont.—Thomas B. Caldwell has purchased the Facer Car Wheel Co.'s plant here.

Vancouver, B.C.—The Vancouver Forge Co., plans extensions to its plant, including the construction of new machine shop.

Niagara Falls, Ont.—The Hydro-Electric Commission are making preparations for the construction of the Chipewewa Creek development.

Toronto, Ont.—The Toronto Lock Mfg. Co. have been granted a building permit for an addition to their machine shop on Patterson Place, to cost \$2,000.

Montreal, Que.—The American Can Co., New York, will erect a can factory at Maisonneuve, and will call for tenders at an early date. N. M. Loney is engineer.

St. Thomas, Ont.—F. N. Gadsby has opened the blacksmith shop next to the London and Lake Erie car barns, Talbot street west, which was conducted by A. Monteith who enlisted recently.

Windsor, Ont.—The Canadian Lamp & Stamping Co. is having plans prepared by Architect Gilbert Jacques, for an addition to its plant to be 1-storey, 60 x 210 feet, brick and steel construction to cost \$25,000.

Sudbury, Ont.—The British American Nickel Co. will build two complete units of the plant near here, and will produce 10,000 tons of nickel a year instead of 5,000, as originally intended.

Dunsmuir, B.C.—The Canadian Colliers, Ltd., has commenced the construction of 120 coke ovens, and is considering 30 coke ovens for the Ladysmith smelter which is preparing to start operations.

St. Mary's, Ont.—Fire on April 22 caused \$8,000 damage at the plant of the Thames Quarry Co. The big new stone-crusher building, situated close to the C. P. R. tracks, was burned to the ground. The loss is covered by \$3,400 insurance.

Toronto, Ont.—A fire, caused by an overheated oil furnace in the forging shop of the John Inglis Co., Strachan Avenue, on April 24, completely gutted the frame structure, and the machinery was badly damaged by water. The damage is estimated at \$25,000.

Sudbury, Ont.—The Board of Control has received a letter from Morris & Hadden, of Buffalo, N.Y., regarding the manufacture in Canada of internal combustion engines of the four-cycle, multiple cylinder type. The firm has been manufacturing in the United States for eleven years, and is thinking of establishing a branch of their industry in Canada.

Cobalt, Ont.—The Northern Ontario Light & Power Co. have taken over the power plant at Charlton, and from this time forward will operate it as part of their large power concern in the north country. The taking over of this plant by the N. O. L. & P. gives this company practically a monopoly of the power plants in the North Country. It is the intention of the new owners to make many improvements and additions to place their new unit on a more up-to-date basis.

Port Hope, Ont.—The Port Hope munition plant, now known as the Port

YARROW'S LTD. TAKE STERN WHEELER CONTRACT

YARROW'S LTD., shipbuilders of Esquimalt, B.C., have been awarded a contract for the construction of another steel sternwheel vessel, and are expecting daily to sign up contract for a fourth boat, all of them being for the same concern which ordered the two already built by the firm. If the fourth order comes along it means that Yarrows, Ltd., will have two of these steel boats under construction in their yard at the same time, which will add considerably to the general activity in shipbuilding on this coast.

The vessels are to be employed on river service in India. They are 132 feet in length, 32-foot beam, with a draft of three feet, and have accommodation for passengers and freight. They will be capable of making a speed of ten knots. The boats themselves are shipped, knock-down, to India via the Blue Funnel boats leaving Victoria, the parts being marked and placed in crates so that when they reach their destination it is a more or less simple matter to rivet the parts together.

All the machinery equipment, including engines and boilers, is being manufactured at the Yarrow plant on the Clyde, being shipped to India from there. The first vessel built in Victoria by Yarrows, Ltd., was shipped across the Pacific on one of the Blue Funnel liners some time ago and the second one is all ready to be shipped on the next sailing of the Blue Funnel liner Protesilaus.

In these days of steel shipbuilding, it is a very difficult matter to get the steel for the smallest sized vessel. The major portion of that used in the construction of these river boats is being secured by Yarrows, Ltd., from the United States. That further orders are being placed here for these boats indicates the satisfaction with which the owners have viewed the work turned out.

Hope Supply Co., is asking the town to guarantee its bonds to the amount of \$50,000. The company, it is said, holds a contract for 3,500 shells per week up to September, and to carry the contract it is necessary to instal additional machinery. Mr. Brandon's proposition is to the effect that the town guarantee his bonds to the amount of \$50,000. The matter will be discussed at a public meeting.

GENERAL

Toronto, Ont.—The Royal Company have been given a permit to erect a one-storey brick factory at 23 River Street, to cost about \$7,000.

Oshawa, Ont.—The W. T. Trick Co., whose factory was recently burned down, have refused an offer of a free site and loan by the town council.

Toronto, Ont.—The Logan Brick Works will construct a brick kiln at 473 Greenwood Avenue at a cost of \$2,500, for which they have obtained the required permit.

New Toronto, Ont.—The Dupont Fabrikoid Co., manufacturer of leather goods, etc., will complete its new plant and be ready for operation in about a month.

Kincardine, Ont.—T. B. Watson, proposes to establish a furniture factory and wants the town to assist with a loan of \$20,000. A by-law will be submitted to the ratepayers.

Portage la Prairie, Man.—A. Forsythe & Co., grain merchants, of High Bluff, have begun the erection of a big elevator in this city. It will have a capacity of 100,000 bushels. It is understood that the company will erect elevators at other points in Manitoba.

Smiths Falls, Ont.—The Ontario Hydro-Electric Commission has decided to come to Smiths Falls, and negotiations are now under way for the taking over of the power sites acquired by G. A. Burgess at High Falls and Rosebank, on the Mississippi river and for the development of them to supply this town, Perth and other places on the line with power.

MUNICIPAL

Hamilton, Ont.—The Board of Control may purchase a motor street flushing machine.

Tillsonburg, Ont.—A by-law will be voted on by the ratepayers on May 14, to raise \$10,000 by way of a loan to the Tillsonburg Foundry & Machine Co.

Simcoe, Ont.—Fire Underwriter's Inspector Norman R. Wilson has reported that a number of improvements are desirable to the fire fighting system here.

Aikenhead's

M-6 Shell Machine

for cleaning out insides of 4.5 inch Howitzer and 6-inch shells and for retouching rough spots.

This machine has been used with immediate success in a number of large shell factories in Canada. A 14½" special spindle is supplied for 4.5 shell work and a 20" spindle is used on 6" shell work. Specially adapted for cleaning the base of shells *inside*.

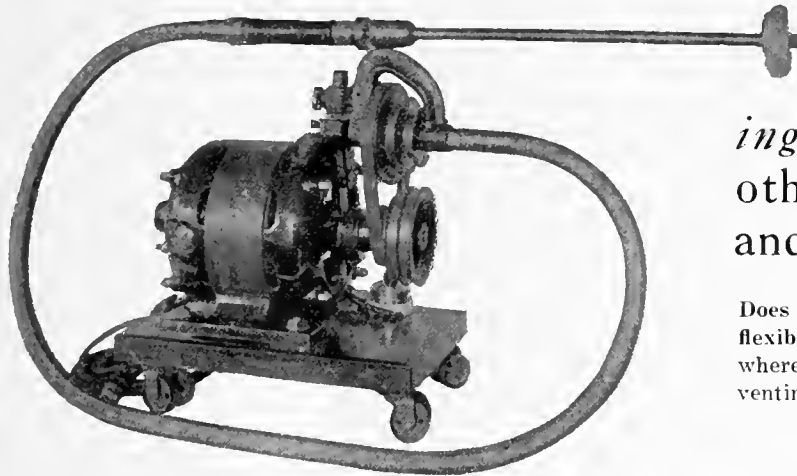

The Strand flexible shaft has a *metal casing* that will outwear any other now on the market and adds life to the shaft.

Does away with the trouble common to other flexible shafts. Freely flexible to a certain radius, where it automatically forms a stop, thus preventing accidental short bends.

For full particulars write

AIKENHEAD HARDWARE LIMITED

17, 19, 21 TEMPERANCE STREET, TORONTO

Aikenhead's New Chuck

Don't Throw Away Broken Tang Drills

Perhaps you are about to discard some taper shank drills because the tangs are broken off—DON'T DO IT—they are worth their weight in gold. You can use them just as they are with a

Wahlstrom Automatic Chuck

One chuck holds drills from 1/16" to 1/4"

and you won't have to take time from your production to repair them.

Tool changes are made in two seconds—just grasp the shell of the chuck with one hand and put in or remove the tool with the other—no collets—no lost time, for the spindle never stops. The jaws grip NOT BY THE TANG, BUT ON THE SIDE OF THE TAPER—there's no chance for slippage—a Wahlstrom won't even mar the shanks.

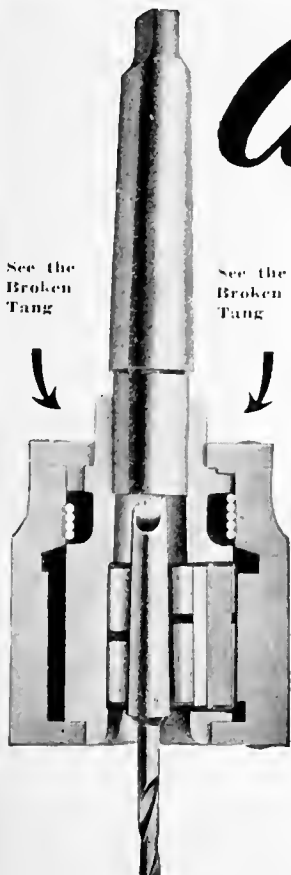

AIKENHEAD HARDWARE LIMITED

17, 19, 21 Temperance Street

Toronto, Canada

If any advertisement interests you, tear it out now and place with letters to be answered.

Aylmer, Ont., proposes to spend \$7,000 for the installation of electrically driven pumps for its waterworks system and a gasoline pump for fire purposes.

Wolseley, Sask.—A by-law has been passed by the Council authorizing a loan of \$9,000 for extension to the municipal light and power plant and deep drainage system.

Aylmer, Ont.—A by-law to install the Hydro-electric was carried here last Monday by a majority of 288. The power will be brought from St. Thomas, and is expected to be in operation within three months.

Winnipeg, Man.—The letting of the half-million dollar aqueduct contract for cast iron piping, valves and specials, was shelved at a meeting of the administration board of the Greater Winnipeg water district, on April 20.

North Bay, Ont.—The Quinlan by-law will be submitted to the ratepayers on May 7. The J. P. Quinlan Mfg. Co. propose to extend their furniture factory and want the company's bonds guaranteed to the extent of \$15,000.

Winnipeg, Man.—Tenders for the supply of cast iron pipe to the Greater Winnipeg Water District were as follows:—United States Cast Iron Pipe & Foundry Co., \$393,888.62; Canada Iron Foundries, Ltd., \$390,290.56; R. D. Wood & Co., \$387,518. No tenders were accepted, and the work will probably be held up until next year.

Alliston, Ont.—A by-law will be voted on by the ratepayers on May 7 to raise \$32,000 to provide for the taking over of the Alliston electric light plant and repairing and improving same for the purpose of distributing electric power to be supplied by the Hydro-Electric Power Commission.

Winnipeg, Man.—Tenders for the supply of valves for the Greater Winnipeg Water District were as follows:—Crane Co., Chicago, \$15,038.70; Canadian Fairbanks-Morse Co., \$12,749.92; Kennedy Valve Co., Elmira, \$12,345.44; Rensselaer Valve Co., Troy, \$12,196.54; General Supply Co., Winnipeg, \$12,184; Drummond, McCall Co., Montreal, \$11,138.25. No tender was accepted.

Port Hope, Ont.—The Town Council has approved of the Nicholson File Co. proposed extensions. The company will build a foot bridge over the river and extend their plant at a total cost of about \$10,000. The council has agreed to submit a by-law to the people, giving the company a fixed assessment of \$35,000 for ten years. Bowman & Connor, engineers, have been requested to make a report on the proposed bridge.

ELECTRICAL

Hamilton, Ont.—City Engineer Gray reports that additional transformers are required for the Beach pumping station. The cost is estimated at \$20,000. The Board of Control has the matter under consideration.

PERSONAL

F. N. Sinclair, of New Westminster, B.C., has been appointed a Dominion pilot commissioner for the pilotage district of New Westminster.

T. M. Jones, of Canadian Allis-Chalmers, Ltd., has joined the staff of the Bawden Machine Co., Toronto, as chief engineer and general manager.

John Collins who has been with the Canadian Steam Boiler & Equipment Co., Toronto, has been appointed manager of H. L. Peiler & Co.'s Toronto office in the Kent Building.

C. N. Schrag, sales engineer of the Ontario District Office of Canadian Allis-Chalmers, Ltd., has resigned to become general sales manager of the Bawden Machine Co., Sterling Road, Toronto.

T. S. Downham is again actively connected as manager with the Canadian Steam Boiler & Equipment Co., Toronto, after a holiday of several months duration. Mr. Downham has fully recovered his health.

Capt. John Baillies, a well-known seafarer, who has plied for years on the British Columbia coast, has received instructions to report to the senior naval officer at Esquimalt for appointment under the new regulations whereby master mariners are taken into the naval service with the rank and pay of "skipper." Captain Baillies is a deepwater man, but for many years has been in the coasting service, and at present he is with the G.T.P.

R. P. Butchart of Victoria, B.C., has been requested by the Imperial Munitions Board to associate with the Board in its work of shipbuilding on the Pacific Coast. A large organization will have to be formed in connection with the plans decided upon for the building of a large number of wooden ships. Mr. Butchart will act as business adviser and will have supervision of the organization on the coast on behalf of the Board. Mr. Butchart is a leading Victoria business man, head of the Pacific Cement Co.

W. Shives Fisher, of the hardware firm of Emerson & Fisher of St. John, N.B., has on request of Sir Edward Kemp, Minister of Militia, on behalf of the Government, accepted an appointment as commissioner in charge of the Dominion rifle factory, formerly the Ross rifle plant, during the period of appraisal. Mr. Fisher is being placed in complete control. His work will involve matters of supplies and outstanding contracts, as well as the investigating of any disputes arising.

Lieut.-Col. T. C. Irving, was recently gazetted as colonel in the 4th Canadian Division. Col. Irving left Toronto with the First Canadian Contingent as a captain in charge of the 2nd Field Company of the Engineers. Capt. Irving received the D.S.O. at the Battle of Langemarck, and shortly afterwards obtained his majority, while the latest gazette raises him to the rank of lieutenant-colonel. Lieut.-Col. Irving was formerly vice-pres-

ident of the C. W. Hunt Co., engineers and the Moffat-Irving Steel Works, Toronto.

George Bury, vice-president of the C.P.R., has arrived in Montreal from Russia, which country he visited at the request of the British and Russian Governments in connection with transportation. He was present in Russia during all the recent revolution. Mr. Bury said that his experience gained by close personal contact and association with Lord Shaughnessy, enabled him to make recommendations which were accepted by the old Russian Government as well as by the new who are now putting these recommendations into force with great vigor.

CONTRACTS

Montreal, Que.—The Board of Control has awarded a contract for the construction of the Lasalle bridge over the aqueduct to A. Pion at the price of \$277,000.

East Angus, P.Q.—The Brompton Pulp & Paper Co. have awarded a contract to the Canadian Allis-Chalmers, Ltd., for water turbines and governors, value \$100,000, and to the Canadian General Electric Co., for generators, excitors, transformers, etc., at \$150,000.

Toronto, Ont.—The Otis-Fensom Elevator Co. have been awarded the contract for nine elevators for the new Union Station. The price is understood to be about \$200,000.

Montreal, Que.—The Board of Control has decided to buy twenty flushing and street cleaning automobiles at a cost of \$146,415. The contract for ten flushing machines was awarded to A. Jennings & Co., furnishing a Kelly-Springfield truck chassis, and the ten sweeping machines will be supplied by the Comet Motor Co., with Packard truck chassis. The flushing machines will cost \$7,399 each and the sweeping machines \$7,242.50 each, making a total of \$146,415.

Trenton, Ont.—Pierhead construction, it is said, has been contracted for at a cost of \$600,000 by the Harbor Commission. The contracts are split among three concerns—R. Weddell & Co., Trenton and Toronto; Port Arthur Construction Co., and J. O. Roddick, Toronto. These three contracts will constitute the summer work on the harbor improvements, and call for the construction of crib superstructures and concrete superstructures of the inner harbor wall. The total distance is 6,000 feet, and it is understood that each concern contracts to construct 2,000 feet of wall.

TRADE GOSSIP

The Burlington Steel Co., of Hamilton, Ont., has increased its capital stock to \$650,000.

Hudson Bay Railway.—According to a statement made by Hon. Frank Cochrane in the House recently, the Dominion has spent \$17,790,587.74 on the Hudson Bay Railway and Port Nelson terminals.

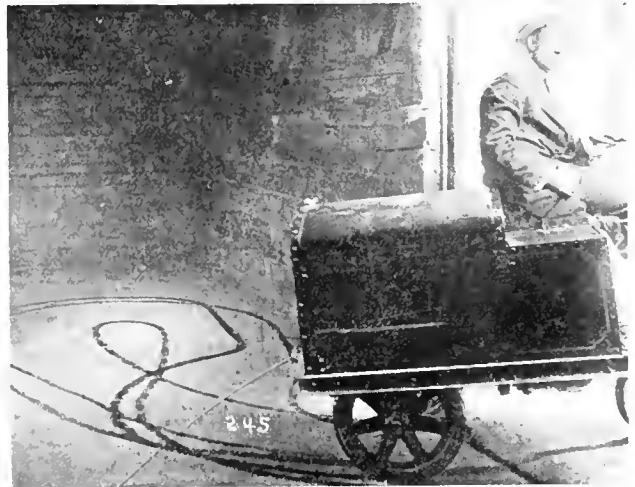
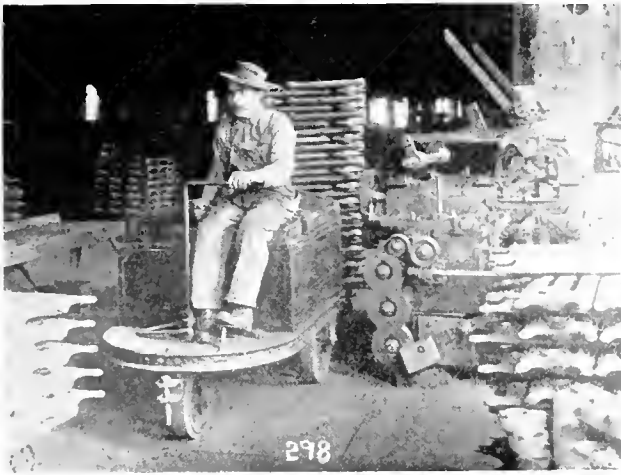

The "Trackless Train" Method

Saves Men—Speeds up Production—Lowers Cost

BETTER use of your present force will help you solve your labor problem. Take those men now pushing trucks, and put them on productive labor where they will figure profits instead of losses.

One man with a Mercury Tractor will do the work of from eight to a dozen truckers—do it quicker and better. Your present trucking equipment (anything on wheels) will serve as trailers.

The engineers of the leading manufacturers in the United States and Canada, after thoroughly testing

and investigating all Industrial Equipments for material movement, now specify Mercury.

The fact that 70% of the Mercury Tractors now in use have been purchased on re-orders, plainly indicates the satisfaction of our many clients.

Take advantage of these various tests, which have proven without a doubt that Mercury is the most economical and practical, and will save more men and money.

Our Engineering Corps, without cost or obligation on your part, will gladly assist in the solution of your problem, making a complete analysis of your material movement, if it is desired.

Write for "Methods and Means," the new hook on the Trackless Material Movement.

MERCURY MANUFACTURING COMPANY

4118 So. Halsted Street

CHICAGO

Represented by

THE FOSS & HILL MACHINERY COMPANY

321 St. James Street MONTREAL, QUEBEC



If any advertisement interests you, tear it out now and place with letters to be answered.

OVENS

Enameling and Varnishing Ovens heated by Gas, Electricity, Steam or Coal. Write for Booklet.

Brantford Oven & Rack Co., Ltd.
Brantford, Canada.

**TRY HAMILTON
BABBITTS**

We Make Nothing Else

GEO. E. JOBBORN, Hamilton, Ont.

**"HAWK" D
CHROME
VANADIUM
STEEL**



Will
Give You
Exceptional

Shell Forging Production

**WITHOUT AN EQUAL FOR
BOTH FIRST AND
SECOND OPERATION
PUNCHES.**

Comes to you heat-treated and ready for use.

It does not stick to the work.

There are many cases where each punch has turned out over 2,000 shells.

It means more shells, per machine per day.

**STEEL OF EVERY
DESCRIPTION.**

**Hawkridge Brothers
Company**

303 Congress St., BOSTON, MASS.
U. S. A.

The Canadian Fairbanks-Morse Co., Toronto and Montreal are asking extended powers to permit of engaging in other manufacturing business than is granted under present articles of incorporation.

War Trophies on Exhibition.—A varied assortment of Vimy Ridge trophies, machine guns, mortars and field guns are being prepared to be shipped out to Canada. These will be a feature of the Canadian National Exhibition at Toronto in August.

B. C. Coal By-Products.—An important branch is to be added to the Mining Department of the Government of British Columbia by the Hon. William Sloan. Special investigations have been made, and it is believed that many useful coal by-products can be exploited for the benefit of the Province.

The Wetmore Mechanical Laboratory Co., of Milwaukee, Wis., makers of special tools such as milling hobs, reamers, taps, etc., for shell production, have opened an office at 608 Kent Building, Toronto, in order to take care of their increasing business in Canada. P. B. Rogers secretary-treasurer of the company is manager of the Canadian office.

Fish Concerns Amalgamate.—An amalgamation of fishing interests in which are merged several of the oldest houses in the fish business in the provinces of New Brunswick, Nova Scotia and Quebec has been consummated, and the new concern is now known as the Leonard Fisheries Ltd., with headquarters at Montreal, with branches throughout the three provinces named, and with a capitalization of \$1,000,000.

G. T. R. Asks Higher Rates.—Presiding at the Grand Trunk meeting in London, England, on April 26, Chairman Smithers said if railways were to continue to exist, higher rates must be charged. Manufacturers and farmers were all highly prosperous, and could afford to pay more, or the railways could not continue to expand their accommodation on which the prosperity of manufacturers and farmers depended in the long run.

Copper Mining in Newfoundland.—The Colonial Government is assisting in the work of developing copper mining activities on the northeast coast of Newfoundland, in the expectation of providing additional supplies of the metal for the Allies. Three large mines in the vicinity of Notre Dame Bay were worked profitably by old methods forty years ago. It is estimated that many million tons can be recovered under modern means.

Embargo on Tin Plate Likely.—Tin plate users and canners in Canada are much perturbed over the possibility of the American tin manufacturers placing an embargo on tin plates and cans. The shortage there is such that canners have been urged to can only perishable fruits, so as to conserve as far as possible supplies. Most of the tin supplied Canada comes from the States, and the proposed embargo would be a serious thing for consumers here.

Quebec, Que.—C. C. Lapierre, of Montreal, has organized an independent cement company that will operate the property owned by the Canada Cement Co., at Neuville, in the county of Port Neuf. This property was bought by the cement merger from the Eastern Canada, the price being a few hundred thousand dollars. The company had already started the building of a mill. The capital of the new company is \$1,250,000, and it is planned to have a daily production of 1500 barrels per day.

Toronto Customs Record.—All records were broken again in April, by the Toronto customs returns, which are approximately given at \$3,650,000 or about \$900,000 in excess of the figure for the same period last year. These figures beat those of March which were \$3,494,174.87 and constituted a record. The total for the four months of this year is \$13,232,413, compared with \$10,303,860 for the first four months of 1916, and just a little over two and a half millions less than the total for the whole period of twelve months in 1915, which was \$15,821,426.

Britain Orders 30 New Steel Ships in Canada.—Sir Thomas White announced in the House on April 23, that orders had already been placed by the Imperial Government for 22 steel vessels in Canadian shipyards. A further order for eight steel vessels would be placed and these ships would total 175,000 tonnage. All the plants in Canada had orders sufficient to carry them into the middle of 1918. He had taken up with the Imperial Munitions Board the question of building wooden vessels in Canada. He was prepared to furnish a ten-million-dollar credit for the building of wooden vessels.

Massey-Harris Reorganization.—At a meeting of the Board of Directors of the Massey-Harris Co., held in Toronto on April 24, the reorganization necessitated by the death of Sir Lyman Melvin-Jones, who for many years was president and managing director, was considered and partially completed. Thomas Findley, former vice-president and assistant general manager, was elected president and general manager; Joseph N. Shenstone, formerly treasurer, was elected first vice-president; C. L. Wisner, formerly secretary, was elected second vice-president, and George Valentine, formerly assistant to the general manager, was appointed general manager.

Investigate White Pine Rust.—Plans for the further investigation into and control of the white pine blister rust have been outlined by the Hon. Martin Burrill, after consultation with the authorities of Ontario and Quebec who will co-operate. The disease destroys much valuable timber, the heaviest infestation being in the Niagara district and certain parts of Quebec. W. A. McCubbin, of the Federal Department of Agriculture, has been appointed to make scientific investigation and co-ordinate efforts in stamping out the pest, while the provinces will co-operate in "scouting" work.

ILLINOIS TOOLS

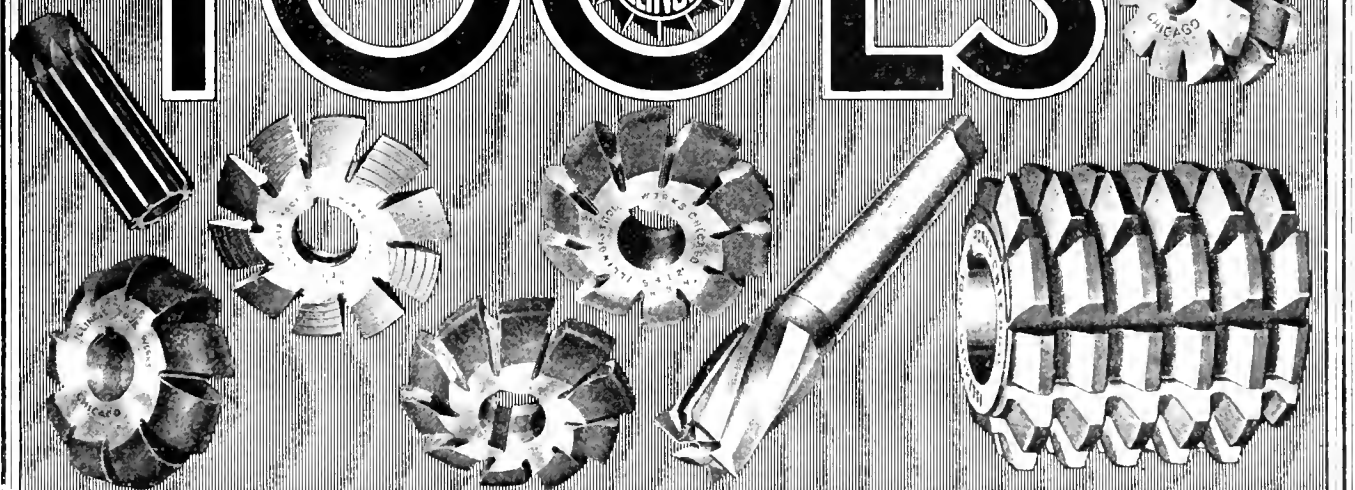

THE manufacturer who includes ILLINOIS ALL-QUALITY TOOLS in his equipment is preparing himself to produce work of the highest degree and at the same time handle greater volume. A fact proved by *results obtained* in many of the country's largest factories.

It will be to your advantage to confer with our engineering department, no matter what are your Hob and Cutter requirements. Standard tools in stock. Prompt delivery on specials. Write or wire for quotations.

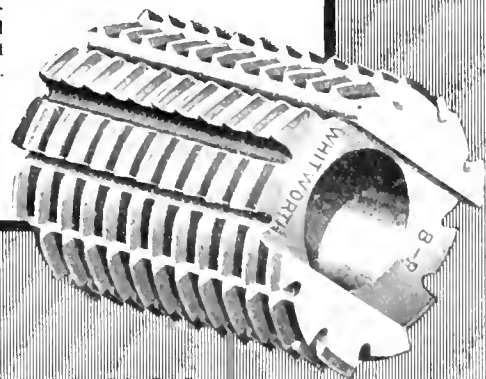
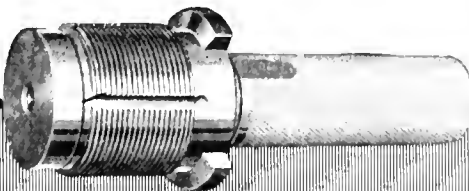

ILLINOIS TOOL WORKS, CHICAGO, U.S.A.

Canadian Representative: ALLAN B. WEARING, Canadian Pacific R.R. Bldg., Toronto, Ontario

If any advertisement interests you, tear it out now and place with letters to be answered.

PATENT ATTORNEYS

BABCOCK & SONS

ESTAB. 1877.
PATENTS—TRADE MARK—DESIGNS
IN ALL COUNTRIES

Book "Patent Protection"—free. Master of Patent Laws. Formerly Patent Office Examiner.

99 St. James St., - Montreal, Que.
Branches: Ottawa, Washington.

RESEARCH BUREAU

REPORTS BY EXPERTS ON SCIENTIFIC, TECHNICAL AND INDUSTRIAL DEVELOPMENT.

SPECIAL RESEARCHES ARRANGED.

PATENTS. TRADE MARKS, ETC.

HANBURY A. BUDDEN CABLE ADDRESS
712 DRUMMOND BLDG., MONTREAL "BREVET"

PATENTS

Fetherstonhaugh & Co.
Patent Solicitors. Head Office,
Royal Bank Bldg., Toronto.
Ottawa Office, 5 Elgin St.
Send for our Plain Practical
Pointers. Copy of National
Progress, in which our patents
are advertised, mailed free.

PATENTS PROMPTLY SECURED

In all countries. Ask for our Investor's Adviser, which will be sent free.

MARION & MARION, 364 University St.
- Merchants Bank Building, corner
St. Catherine St., MONTREAL, Phone Up. 8474
and Washington, D.C., U.S.A.

ON PAGE 80

You'll find a host
of Opportunities.

TURN TO IT!

THE IRON WORKS

Successors to

LIMITED

Owen Sound Iron
Works

Owen Sound,
Ont.

Engineers

Boiler-
makers

Founders

Machinists

Tank Work
Smoke Stacks,
Grey Iron and
Brass Castings,
Special
Machinery
Made to
Order

Ross Rifle Factory Expropriation.—A copy of the Order-in-Council passed a month ago providing for the expropriation of the Ross rifle factory at Quebec by the Government was tabled in the Commons on April 24. The Order provides that the price to be paid for the property owned by Sir Charles Ross shall be determined by the Exchequer Court, but shall not exceed three million dollars. It is further provided that Sir Charles Ross shall not receive anything in consideration for the site which was granted to him for the factory when the original contract was made in 1902, but that this site shall revert to the Crown.

Commission Reports on C. N. R.—The special commission appointed to investigate the affairs of the Canadian Northern Railway has submitted its report to the Dominion Government. The commission was composed of Edward E. Loomis, president of the Lehigh Valley Railway, and John W. Platten, president of the U. S. Mortgage and Trust Co., New York. They were assisted by the firm of railway experts, Coverdale & Colpitts, of New York. The report is of considerable length, and is entirely favorable to the railway. It states briefly that the transcontinental undertaking is fundamentally sound, and that the capital invested has been economically secured and wisely expended.

Toronto Union Station.—The work is proceeding in a manner, considering war time, that is satisfactory to the engineers, and they declare that the contracts are not more than two months behind the original time specified. Chief Engineer J. R. W. Ambrose stated recently that wings could be ready for occupation about a year from next August, and that the station proper would be completed about two years from now. The structural steel work will be completed about May 15, while it is hoped to have the wings enclosed by the stone work within six weeks. The masonry work is progressing favorably, and the walls up to the main floor of the station proper are nearly finished, and it is expected that all the stone will be in place within the year.

Canadian Shipping Increased in March.—An increase in the tonnage of shipping on the Canadian register took place during the month of March, according to statistics prepared by the Department of Marine, Ottawa. At the close of February there were steam vessels with aggregate tonnage of 794,314 tons, and sailing vessels of total tonnage of 475,693 registered in Canada. At the end of March the tonnage of steam vessels was 812,906, and of sailing vessels 476,301. During the month steamers aggregating 26,677 tons were added to the register, chiefly by transfers from Great Britain, and 6,628 tons were stricken off by reason of wrecks or unfitness for use. Sailing vessels of an aggregate of 6,294 tons were added to the list, and others of 5,686 tons, which were wrecked or broken up as unseaworthy, were dropped from the register.

No Time Extension on Demurrage Rates.—The Dominion Railway Commis-

sioners have refused to grant the railways an extension of the time over which the increased demurrage charges may apply. Accordingly, after the end of the month the old rates and duration of free time will apply. Last fall, on account of the great car shortage, that prevailed throughout America, permission was granted the railways to increase the charge of one dollar per day for each day a car was held after the expiration of the free time to a graduated one that reached five dollars per day within a few days after the expiration of this free time. The length of the free time was also decreased. The railways have recently submitted to the board a new set of car demurrage rules containing several contentious clauses, and in which \$3 per day demurrage is asked after 48 hours free time has elapsed.

TENDERS

Toronto, Ont.—Tenders will be receivable up to May 5, for supply of approximately 100 tons of pure soft pig lead for the York Township. Further information may be obtained at Township Engineer Frank Barber, Toronto.

Winnipeg, Man.—Tenders for the additions to the city light and power plant at Point du Bois, decided on in January by the city council, are to be called at once and will close May 15, so that no time will be lost in taking advantage of the summer working season. The new work which will include the installing of generators sufficient to carry the constantly increasing load for many years to come, will cost approximately \$180,000.

Trenton, Ont.—Tenders will be received until May 15, for the erection of a nine-roomed Collegiate Institute in the town of Trenton, Ont. Plans and specifications may be seen at the Architect's office or at the office of C. W. Saylor, Chairman of Committee, Trenton. All information, tender forms, etc., may be had at the office of S. B. Coon and Son, Architects, Excelsior Life Building, Toronto Street, Toronto.

Dungannon, Ont.—Tenders, addressed to the undersigned, will be received up to May 12, for the material, plant and equipment of the Ontario West Shore Railway between Goderich and Kincardine. The material is practically all on the right-of-way, and consists approximately of six pairs of steel bridge girders for bridges of 25 ft. to 70 ft. spans; 2,400 cedar fence posts, 8 ft.; 710 boxes of spikes (about 324 lbs. to box); 135 boxes of bolts (about 125 lbs. to box); a large quantity of fish-plates; one engine, three flat-cars, scrapers, etc., used in construction work; a quantity of square timber, from 8 ft. to 24 ft. long; about 2,000 feet of 2 in. hardwood plank; about 900 tons of 70-lb. steel rails; also fourteen miles of track of 70-lb. rails, bolts, spikes, fish-plates, ties, bridges, etc., laid complete. For further particulars apply to the trustee, Thomas Stothers, Dungannon, Ont.

BUILDING

Toronto, Ont.—A building permit for a one-storey brick warehouse at the corner of Dufferin Street and Lappin Avenue, was granted to the Royal Flying Corps by the city architect.

Toronto, Ont.—The City Architect has issued a building permit to Western Canada Flour Mills Co., for the construction of a three-storey reinforced concrete warehouse and elevator, on Maepheron avenue, near Poplar Plains, at a cost of \$20,000.

Toronto, Ont.—The Dominion Waste Co. will soon erect a three storey brick addition to their warehouse and an additional storey to the warehouse at the southwest corner of Paton Road and Browns Road at a cost of \$20,000. The building permit for the work has been taken out at the City Architect's Office.

Toronto, Ont.—The Wellington Properties Corporation, will erect a seven-storey reinforced concrete warehouse building costing \$300,000, on the Baldwin Estate property at the corner of Bay and Wellington Streets. The first two stories will be Indiana limestone, and will have a frontage of 212 feet on Bay Street with a depth of 73 feet on Wellington Street.

WOODWORKING

Collingwood, Ont.—Wilson Bros., whose planing mill was recently destroyed by fire will probably rebuild. The company has been reorganized and tenders are being called for clearing the site and purchase of scrap.

Toronto, Ont.—A syndicate headed by M. K. Haney is understood to have taken over the lumber mill and plant of the Canadian Pacific Lumber Co., at Port Moody, B.C. The mill, which is situated on Tidewater at Burrard Inlet, will be improved and operated to its full capacity. Associated with Mr. Haney are Richard P. Gough, C. A. Barnard and J. F. M. Stewart of Toronto.

RAILWAYS—BRIDGES

Ottawa, Ont.—The Manitoba & Ontario Railway Co., is applying to Parliament for an act of incorporation authorizing the construction of a railway line from Brereton Station, on the National Transcontinental, in Manitoba, to the English River, in Ontario, and thence northerly to Hudson Bay, between the mouths of the Albany and Nelson rivers.

Windsor, Ont.—A fire, supposed to have originated from spontaneous combustion, broke out in the Kingsville car barns of the Windsor, Essex & Lake Shore Railway on April 25. Three passenger coaches and an electric locomotive were badly damaged; they will be out of use for some time. General manager Eastman was unable to place a close estimate on the damage, but the material and equipment in the barns represented \$150,000.

Toronto, Ont.—Good progress is being made on the construction of the Bloor street viaduct, and it is the opinion of

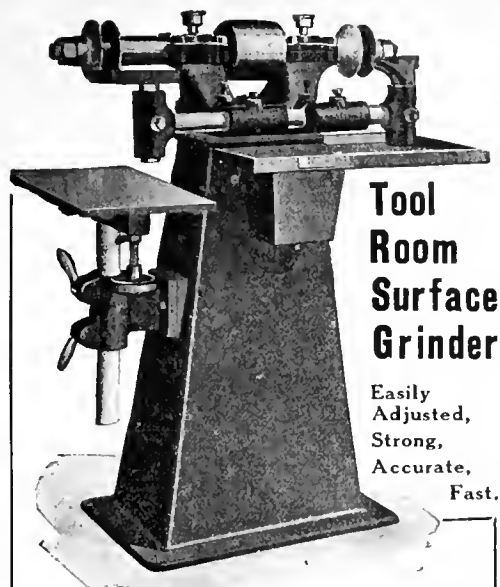

Tool Room Surface Grinder

Easily Adjusted, Strong, Accurate, Fast.

Has rigid grinding surface and large tray and water pot combined. It's an unbeatable tool room surface grinder. Tell us your machinery wants—experts on special designs. Satisfaction assured.

J. E. WING & SON, HAMILTON CANADA

MORTON MANUFACTURING CO.
 PORTABLE PLANERS
 DRAW CUT SHAPERS
 SPECIAL DRAW CUT R R SHAPERS
 FINISHED MACHINE KEYS
 STATIONARY & PORTABLE KEY WAY CUTTERS
 SPECIAL LOCOMOTIVE CYLINDER PLANERS
 OFFICE AND WORKS: MUSKEGON HEIGHTS U.S.A.

No. 4 Press
10 to 12 tons.

Write for complete information on Atlas Arbor Press. All sizes for all purposes.

ATLAS PRESS CO.
330 N. Park St.
Kalamazoo, Mich., U.S.A.

ECONOMY No. 40 HEAVY DUTY, the EFFICIENT SHELL SAW

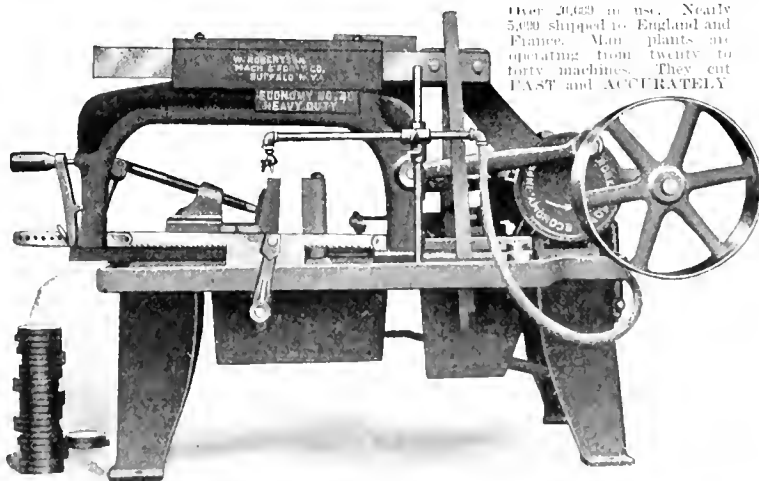

Over 20,000 in use. Nearly 5,000 shipped to England and France. Many plants are operating from twenty to forty machines. They cut FAST and ACCURATELY.

Draw Cut Oil Compression Lath, relieving the strain on the return stroke. 1 1/2 inch diameter for and 1 break blades. Quick Acting Vice. Cut Great. Power Drive. Automatic Stop. Capacity 8 X 8". Take blades from 10 to 17". This tool will give better production at less cost than any tool in your plant. Econom Saw is built in sizes up to 18 X 18". PROMPT DELIVERIES.

W. Robertson Machine & Foundry Company, Buffalo, N.Y., U.S.A.

Cameron Babbitt Retainer

(Patented in Canada and the U.S.A.)

Not like clay or other material, as it does not stick to the work or hands. Does away with using leather or paste-board at end of box.

The only satisfactory compound for retaining molten metal and can be used over and over again for months—no deterioration.

For any metal.

For prices and samples apply to

A.S.K. Chemical Company, Elora, Ontario

I BELIEVE

*In Safety First and always,
In providing for the Health of my Fellow
Workmen,
In Light and Air and sanitary Working Con-
ditions,
In clean, fresh drinking water for everybody,
In the Safety, Economy and Man-betterment.*

PURO SANITARY DRINKING FOUNTAIN

(MADE IN CANADA)

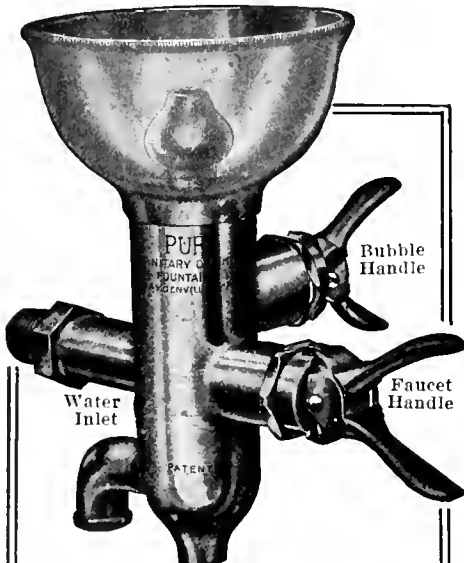

The loss of a man through impure drinking water is a crime that "the front office" must bear.

An ugly statement, isn't it? But true, absolutely.

When a man comes to work in your factory he puts his health in your keeping.

Are you willing to take chances on such a trust?

Impure drinking conditions are responsible for more tragedies than any machine ever built.

Apply the "Safety First" Principles to your water supply; don't deny your men a clean, fresh drink of water.

Conserve their health and they will improve your profits; make yourself as worthy of the name of "employer."

Install the Gold Medal winner Puro in your plant, office and shop alike.

The only Sanitary Drinking Fountain that is safe, sanitary, simple, automatic in control and easily attached.

Let us tell you just what it will cost you to

"PURO - FY"

YOUR WATER SUPPLY

Puro Sanitary Drinking Fountain Company
147 University Ave., Toronto, Canada

"Barnes-Made" SPRINGS

are unusual in service and wear

They are the result of sixty years' experience, unsurpassed equipment and highly skilled workmanship.

A trial will convince you that "Barnes-Made" Springs are the best buy.

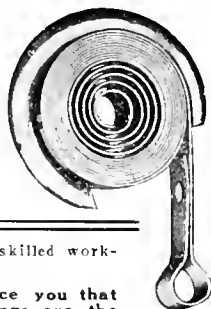

Established 1857.

THE WALLACE BARNES COMPANY
218 South St., Bristol, Ct., U.S.A.

Mfrs of "Barnes-made" Products
Springs, Screw Machine Products, Cold Rolled Steel and Wire

Works Commissioner Harris that the Rosedale section will be open for traffic from Parliament street about the end of July. There is no possibility, he states, of the viaduct being completed and ready for through traffic before the summer of next year. The agreement with the contractors expires on December 24 of this year, but the work has been greatly delayed by the severe weather, and it will likely be late spring of next year before it is completed.

MARINE

Pilot Charges Raised.—An Order-in-Council has been passed increasing pilotage rates. The charge for pilotage for any sea-going vessel has been increased from \$3 to \$3.25 for each foot of draught, and for coasting vessels, from \$2.50 to \$2.75, but the charge for in-land vessels remains at \$2.50.

Sault Ste. Marie, Ont.—Ice conditions at Whitefish Point this year have delayed navigation at least ten days past the time that the freighters are usually able to proceed on their course up the lakes, which will mean a big loss to the shipping interest. A large number of vessels have been held up at the Soo.

North Vancouver, B.C.—The auxiliary schooner Jesse Norcross, which was launched on April 25 at the Wallace Shipyards, was named after J. Norcross, vice-president and managing director of the Canada Steamship Lines, director of Canadian-Vickers, and recently appointed by the Dominion Government to have charge of the national shipbuilding scheme.

Sarnia, Ont.—The deal whereby the holdings of the Reid Wrecking Co., including tugs, steamers, etc., with the exception of the drydock property, are to be disposed of to outside parties, is still pending, according to the statements of the officials of the company. No further details of the transaction, than those already published will be given out by the company until the deal is consummated.

Haileybury, Ont.—The boats of the Temiskaming Navigation Co., which ply between points on Lake Temiskaming, with headquarters at Haileybury, have been sold to Mr. Seymour, the member for Pontiac County, representing Ville Marie interests. The line will be operated this coming season under the name of the Ville Marie Navigation Co. Mr. W. Chenier, of Ville Marie, is the new manager.

Victoria, B.C.—The speedy C. P. R. steamer Patricia, which regularly maintains the service between Nanaimo and Vancouver, is again on the ways at the Victoria Machinery Depot for the third time within about as many months, the cause of her being laid up on the present and the last previous occasion being the same in both cases, namely, that the vessel struck some submerged object resulting in injury to one of her propeller shafts.

Victoria, B.C.—The G. T. P. steamer Prince Rupert will be repaired at Yarrows, Ltd., Esquimalt. Reports already received here from Prince Rupert and

the scene of the wreck indicate that the damage is very extensive, extending over a length of 180 feet. The repairs are expected to take a period of about three months. The difficult feat of salving the Prince Rupert was carried out by the B. C. Salvage Co., under the direction of Capt. T. Thompson.

Ferry "St. Louis" Sunk.—The St. Louis, owned and commanded by Captain P. McLean, sank on the morning of April 20, at its moorings in the Elgin Basin, Montreal. The vessel had seemed all right when the captain left it on the previous night, but at 7 o'clock the following morning only the bow was above the water, being held in that position by the mooring ropes. The St. Louis has been in the Verdun and La Tortue ferry service for the last ten years. Ice is stated to have caused the sinking. The vessel, which is of 269 tons, will be raised.

Canadian Vessel Rammed.—The Canadian freighter Durley Chine, bound in ballast from a Canadian to an American port, was rammed and sunk on the morning of April 22, in collision with an out-bound British freighter, about sixty-five miles east of Sandy Hook. The latter vessel returned to New York with her bow stove in, leaking badly forward, and brought in the captain and the twenty-eight men of the crew of the Durley Chine. She will probably discharge her cargo and go into dry dock for repairs. According to the captain of the damaged vessel, he left New York the previous afternoon. His vessel struck the Durley Chine amidships and almost cut her in two. The Durley Chine was a single screw steamship of 1,918 gross tonnage, built in Sunderland in 1912, and owned by the Canadian Government. She was 279 feet long, 40 feet one inch beam, and 18 feet four inches deep of hold.

INCORPORATIONS

J. & P. Davignon Ltd., has been incorporated at Ottawa with a capital of \$45,000 to carry on business as contractors and engineers at Montreal. Incorporators are Joseph and Pierre Davignon and Joseph A. Lacasse all of Montreal.

C. L. Perkins Ltd., has been incorporated at Toronto with a capital of \$45,000 to take over as a going concern the business of C. L. Perkins Machine Co., Ottawa. Provisional directors are James P. McMullen and Matthew J. Armstrong of Ottawa.

Welland Shipbuilding Co., has been incorporated at Ottawa to carry on the business of constructing ships and other general construction business at St. Catharines, Ont. The incorporators are Francis H. Keefer, Harold A. Keefer and Donald Munro all of Thorold, Ont.

Ontario Molybdenum Co., has been incorporated at Toronto with a capital of \$40,000 to carry on the business of mining, smelting and refining metals. The head office is at Toronto and the incorporators are Theodore Burrel, Irene O. Allan and Lily Guylar all of Toronto.

CANADIAN MACHINERY

AND MANUFACTURING NEWS

A weekly newspaper devoted to the machinery and manufacturing interests.

Vol. XVII.

TORONTO, MAY 10, 1917

No. 19

EDITORIAL CONTENTS

Machining the 18-Pounder High Explosive Shell	473-476
Production Methods and Devices	477-479
Interesting Wave and Groove Machine....Nicking of Shell Noses....Machining Wooden Fuse Plugs....Staybolt Riveting Kink.	
General	479
Engineering and Other Munitions Work in the Field.	
Spokes in Industry's Wheel	480-481
George Chadwick Gregson.	
General	481
Britain's Ore and Pig-Iron Supply....Preserve Field Products From Loss by Fire.	
Editorial Correspondence	482-487
Machinists' Instruction Course—XX....Calculating the Weight of a Flywheel.... Strategic Value of Cape Breton Island....Annual Meeting of Mining Society of Nova Scotia....The Metric System and Post-War Development....Canada's March Export Trade.	
Progress in New Equipment	488-490
Boring and Recessing Machine for Aircraft Manufacture....Metal Melting in a Simple Crude Oil Furnace.	
Editorial	491
Developing Our Shipbuilding Along Right Lines.	
Selected Market Quotations	492-493
The General Market Condition and Tendency	493-496
Summary....Montreal Letter....Toronto Letter.	
Industrial and Construction News	497-498

THE MACLEAN PUBLISHING COMPANY, LIMITED

JOHN BAYNE MACLEAN, Pres. II. T. HUNTER, Vice-pres. H. V. TYRRELL, Gen. Man.

Publishers of Hardware and Metal, The Financial Post, MacLean's Magazine, Farmer's Magazine,
Canadian Grocer, Dry Goods Review, Men's Wear Review, Printer and Publisher, Bookseller and
Stationer, Canadian Machinery and Manufacturing News, The Power House, The Sanitary Engineer,
Canadian Foundryman, Marine Marine Engineering of Canada.

Cable Address: Macpubco, Toronto; Atabek, London, Eng.

ESTABLISHED 1887

CANADIAN MACHINERY

AND MANUFACTURING NEWS

PETER BAIN, M.E., Editor. B. G. NEWTON, Manager.
Associate Editors: A. G. WEBSTER, J. M. WILSON, J. H. RODGERS.

CHIEF OFFICES:

CANADA Montreal, Southam Building, 128 Bleury Street, Telephone 1904; Toronto, 113-113 University Ave.
Telephone Main 7324; Winnipeg, 22 Royal Bank Building, Telephone Garry 2315.

GREAT BRITAIN LONDON, The MacLean Company of Great Britain, Limited, 55 Fleet Street, E.C.4, E. J. Dadd,
Director, Telephone Central 12960, Cable Address: Atabek, London, England.

UNITED STATES New York, R. R. Huestis, Room 620, 141 Broadway, N.Y., Telephone Rector 8971; Boston, C. I.
Morton, Room 733, Old South Building, Telephone Main 1294. A. H. Byrne, 1104-5-6, Fort Dearborn Bldg.,
105 W. Monroe St., Chicago, Telephone Randolph 3231.

SUBSCRIPTION PRICE Canada, Great Britain, South Africa and the West Indies, \$3.00 a year; United States,
\$3.50 a year, other countries, \$4.00 a year; Single Copies, 15 cents. Invariably in advance.

Anybody Can Operate This Miller and Turn Out a Pile of Work So Simple to Operate is the "HENDEY"

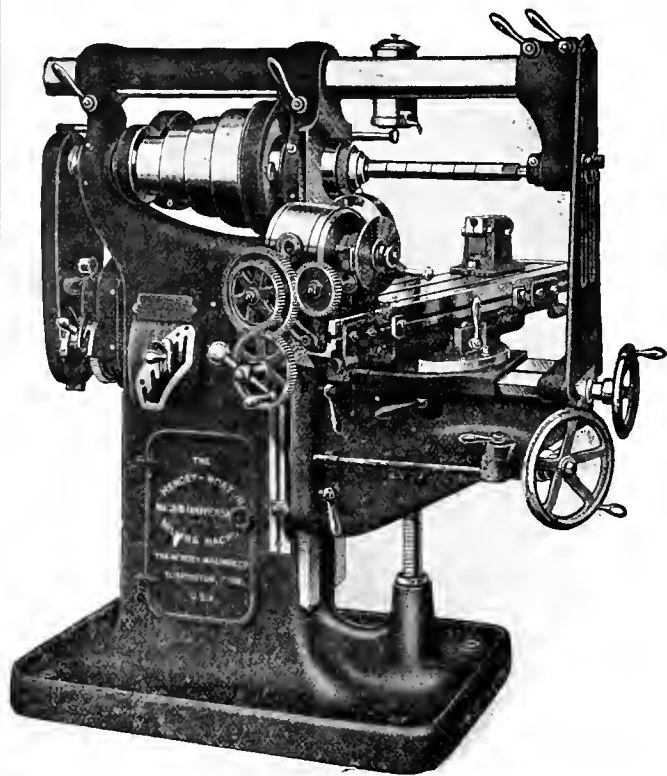

Skilled mechanics are scarce these days—but anyone can run a machine of its simplicity and turn out work accurately and fast without trouble.

All Feeds positive driven through gearings giving 18 changes.

This is the universal type—designed to handle all milling operations performed on machines of this character, either with regular equipment or by aid of attachments, which can be supplied for increasing efficiency and scope of machine.

Write for full description.

The Hendey Machine Co.

Torrington, Conn., U.S.A.

Canadian Agents: A. R. Williams Machinery Co., Toronto, Ont.;
A. R. Williams Machinery Co., 260 Princess St., Winnipeg; A. R.
Williams Machinery Co., Vancouver; A. R. Williams Machinery Co.,
St. John, N.B.; Williams & Wilson, Montreal.

INDEX TO ADVERTISERS

A	
Adams, Ogden R.	94
American Pulley Co.	79
Armstrong Bros. Tool Co.	95
Armstrong, Whitworth of Canada.	14
A. S. K. Chemical Co.	63
Atkins, Wm., & Co., Ltd.	11
Atlas Crucible Steel Co.	14
B	
Babeck & Sons	62
Baird Machine Co.	94
Banfield, E. J.	16
Banfield, W. H., & Sons	63
Barnes, Wallace, Co.	64
Bath, Cyril J.	68
Baxter & Co., Ltd., J. R.	15
Beatty & Son, M.	70
Bertram, John, & Sons Co., Ltd.	1
Bilton Mach. Tool Co.	20
Blake & Johnson Co.	103
Bliss, E. W., Co.	83
Blomst, I. G.	107
Brantford Oven & Rack Co.	65
Bridgford Mach. Tool Works	16
Bristol Company	91
Brown Engineering Corp.	74
Brownell Machy. Co.	70
Brown's Copper & Brass Rolling Mills	6
Budden, Haubury A.	62
C	
Can. Boud Hanger & Coupling Co.	81
Canada Machinery Corporation	
Outside back cover	
Can. B. K. Morton Co.	4
Can. Fairbanks-Morse Co.	34
Can. Blower & Forge Co., Ltd.	107
Can. Desmond-Stephan Mfg. Co.	85
Can. Economic Lubricant Co.	81
Can. Ingersoll-Rand Co., Ltd.	20
Can. Inspection & Testing Labora- tories, Ltd.	91
Can. Mathews Gravity Camer Co.	65
Can. Metal Products	74
Can. Morehead Mfg. Co.	80
Can. Steel Foundries, Ltd.	7
Can. S K P Co., Ltd.	23
Carlyle Johnson Mach. Co.	8
Chapman Double Ball Bearing Co.	81
Chicunati Pulley Machy. Co.	101
Cleveland Pneumatic Tool Co.	28
Clipper Belt Lacer Co.	80
Colonial Steel Co.	80
Constedt Co., Josef P. A.	77
Cook, Asa S.	93
Cooper Co., C. & G.	72
Cullen Machy. Co., C. W.	18
Cummings & Son, Ltd., J. W.	107

Curtis & Curtis Co.		23
Cushman Chuck Co.		90
D		
Davis-Bourneville Co.		92
Davis, W. F., Machine Tool Co.		71
Deloro Smelting & Refining Co.		17
De Mooy Mach. Co.		99
Dominion Machinery Co.		69
Dominion Steel Foundry Co.		91
Dunry Co., H. A.		10
E		
Eastern Mach. Screw Corp.		89
Elmes, Chas. F.		82
Eric Foundry Co.		82
F		
Fairley, Davidson Steel Co.		8
Fetherstonhaugh & Co.		62
Pitzgerald, W. H. J.		68
Foss & Hill Machy. Co.		20
G		
Francis & Co.		93
Goldie & Buchanan Co.		69
G		
Ganther Machine Co.		105
Garlock-Walker Machy. Co.		22
Garvin Machine Co.		20
Geometric Tool Co.		81
Gibb Instrument Co.		78
Gilbert & Barker Mfg. Co.		
Front cover		
Giant Gear Works, Inc.		92
Grant Mfg. & Machine Co.		26
Greenfield Machine Co.		92
H		
Hamilton Gear & Machine Co.		75
Hamilton Machine Tool Works.		19
Hanna & Co., M. A.		15
Hawkridge Bros.		63
Hendey Machine Co.		112
Henry & Wright Mfg. Co.		98
Hepburn, John T.		18
High Speed Hammer Co.		26
Hilmoft Mach. Co.		94
Hott Metal Co.		91
Hull Iron & Steel Edries, Ltd.		86
Hunter Saw & Machine Co.		65
Hungerford Brass & Copper Co.		76
Hurlbut-Rogers Machinery Co.		86
Hyde Engineering Works		67
I		
Ideal Tool & Mfg. Co.		87
Independent Pneumatic Tool Co.		30
Iron Works, The		63
J		
Jacobs Mfg. Co.		88
Jenkins Mach. Co.		9
Jersey City Mach. Co.		23
Johnson, Geo. E.		63
Johnson Mach. Co., Carlyle		8

Jones & Glasco		82
K		
Kennedy, Wm., & Sons		16
King, Ltd., Warden		24
L		
L'Air Liquide Society		84
Landis Machine Co.		92
Lancashire Dynamo & Motor Co.		29
Lathro Electric Steel Co.		10
Leid-Farquhar Co.		70
M		
MacKinnon, Holmes & Co., Ltd.		62
Magnolia Metal Co.		94
Manufacturers Equipment Co.		89
Marion & Marion		62
Maish & Henthorn, Ltd.		103
Matthews, Jas. H., & Co., Inc.		31
McCabe, J. J.		72
McCoy-Brandt Machy. Co.		68
McDonnell Co., H.		70
McKinnon Dash Co.		70
McLaren, J. C., Bolting Co.		92
Mechanical Engineering Co.		78
Metal Manufacturers' Service		73
Metalwood Mfg. Co.		83
Miller Smythe Electric Co.		67
Miholland Co., W. K.		21
Monarch Brass Mfg. Co.		75
Montreal Machy. & Supplies.		99
Morse Twist Drill & Mach. Co.		97
Morton Mfg. Co.		65
Murechy Machine & Tool Co.		87
N		
Napier Saw Works, Inc.		92
National Machine Tool Co.		93
New York Machinery Exchange.		09
Nicholson File Co.		101
Niles-Bement-Pond.		Inside front cover
Northern Crane Works		91
Norton, A. O.		92
Norton Co.		32
Nova Scotia Steel & Coal Co.		12
O		
Ontario Specialties, Ltd.		107
Oven Equipment & Mfg. Co.		80
Oliver Machy. Co.		18
P		
Parmenter & Bulloch Co.		107
Peck, Stow & Wilcox Co.		84
Peerless Machine Co.		85
Perrin, Wm. R.		83
Petrie of Montreal, H. W.		67
Petrie, H. W., Ltd.		67
Port Hope File Mfg. Co.		31
Positive Clutch & Pulley Works.		94
Pratt & Whitney.		Inside front cover
Pringle, R. E. T., Ltd.		29
Puro Sanitary Drink'g Fountain Co.		64

R		
Racine Tool & Machine Co.		85
Rhodes Mfg. Co.		97
Richmond Mfg. Co.		89
Riverside Machy. Depot		65, 68
Rivett Lathe & Grinder Co.		110
Roelofson Machine & Tool Co.		5
Roper & Co., C. F.		79
S		
Shuster Co., F. B.		94
Silver Mfg. Co.		93
Skinner Chuck Co.		91
Slocum, Avram & Slocum		29
Smalley-General Co.		73
Smart-Turner Mach. Co., Ltd.		35
Standard Alloys Co.		15
Standard Electrical Tool Co.		28
Starrett Co., L. S.		25
Steel Bending Brake Works, Ltd.		92
Stetcher Co., Chas.		21
Steel Co. of Canada		3
Stoptoe, John Co.		82
Stocker-Rumley-Wachs Co.		71
Stow Mfg. Co.		30
Sturtevant Co., B. F.		86
Swedish Gage Co., Inc.		27
Swedish Steel & Importing Co.		
T		
T. C. M. Mfg. Co.		21
Tabor Mfg. Co.		95
Tate-Jones & Co., Inc.		80
Taylor Instrument Co.		78
Toledo Machine & Tool Co.		83
Toomer, Frank A.		72
Toronto Iron Works		91
Toronto Testing Lab.		94
Toronto Tool Co.		74
Trahem Pump Co.		79
U		
United Hammer Co.		92
United States Electrical Tool Co.		31
V		
Vanadium Alloys Steel.		12
Vulcan Crucible Steel Co.		10
W		
Waleott Lathe Co.		18
Warner & Swasey Co.		23
Wells Bros. Co. of Canada.		23
Whiting Foundry Equipment Co.		103
Whitman & Barnes Mfg. Co.		109
Williams, A. R., Machinery Co.		7, 61
Williams & Co., J. H.		25
Wilson & Co., T. A.		92
Wilmarth & Morman Co.		92
Windsor Mach. & Tool Works.		24
Winnipeg Gear & Engineering Co.		74
Z		
Zenith Coal & Steel Products Co.		93



Machining the 18 Pounder High Explosive Shell

By A. F. Menzies

Although in the initial period of Canada's munitions industry, the production of 18-pdr. high explosive shell contributed no inconsiderable part of the general activity, the demand for this size and type projectile fell off comparatively early, and gave little promise of being again revived. A few months ago, however, further orders were placed with our metal-working plants, the machining procedure of the latter constituting the subject of this article.

THE operations, methods and devices herein described were observed in a shop turning out four hundred 18-pdr. high explosive shells every twenty-four hours. The work carried the shells to the plugged stage, the banding, varnishing, etc., being done at a central plant. As the shifts were of 11 hours each, operations for which there was only one machine had to be arranged to allow of their being performed in not more than three minutes, including an allowance for changing and setting tools, etc. This gave an output of 20 shells per hour, which allowed for losses due to defective material and rejections. The equipment employed consisted in the main of standard machine tools fitted with special attachments, which were all made on the premises. Special single purpose machines were built for some of the operations, some also being designed and built in the shop.

Cutting Bars to Length

The shell steel was received in bars of varying length up to 10 ft. 3 in., and was measured with a long rule graduated on one side in feet and other side in billet lengths. The first operation was to cut the bars into lengths of 19 $\frac{3}{4}$ in. on two Racine high speed draw-cut hack saws. The saws were speeded to 112 strokes per minute, and made a cut in about 11 minutes. The blades 10 in. x $\frac{3}{4}$ in. x 18 gauge, had 11 teeth per inch, and were supplied by H. Diss-ton & Sons. They were changed when-

ever the time to make a cut had risen to about 14 minutes. From 8 to 10 blades per shift was found to be sufficient. The discarded blades, while too slow for this work, had still a lot of life in them, and were kept for cutting the square shank off the base-plates and for cutting soft steel. A convenient table was provided to serve the saws. It was built to hold sufficient steel to run a shift, and was filled night and morning by the day shift. The height of the table was such that the operator could easily roll the bars into the rollways leading to the saws. Fig. 1 shows the saws with the steel table behind them.

The second operation, parting the 19 $\frac{3}{4}$ in. piece into two billets was done on a special machine. This consisted of a cast iron head carrying a hollow spindle. The head was secured to a pair of I-beams which formed the bed, and which also carried the compound rest. The piece

to be parted was pushed into the hollow spindle, and secured with two set screws. The parting tool was a piece of 3/16 in. x 2 in. high speed steel held in a mild steel holder. The tool was fed into the work by hand until the parting was about 1 $\frac{3}{4}$ in. diameter, after which the piece was withdrawn and broken across a length of shafting secured to the floor. The broken end was made the base of the shell, and the fracture was examined by the Munitions Board examiner before more work was done on the billet. For examination, the billets were stacked fractured ends up in a box holding a series. After being examined and found O.K., the acceptance mark was placed on the billet. The parting machine is shown on the extreme left, in Fig. 1. It was driven at 67 revolutions per minute by a 6 in. quarter-turn belt.

Drilling Billets

The drilling was done by the inverted method, three machines being used, two of which are shown in Fig. 2. This method of drilling has much to commend it in comparison with the usual method of using twist drills. The billets being inverted, the chips fall out readily and the cutting compound is delivered to the place where it is wanted. Excellent proof of this is obtained by feeling a billet drilled in the usual manner and then feeling one drilled by the inverted method. The latter will be found quite cool, while the former will be found,

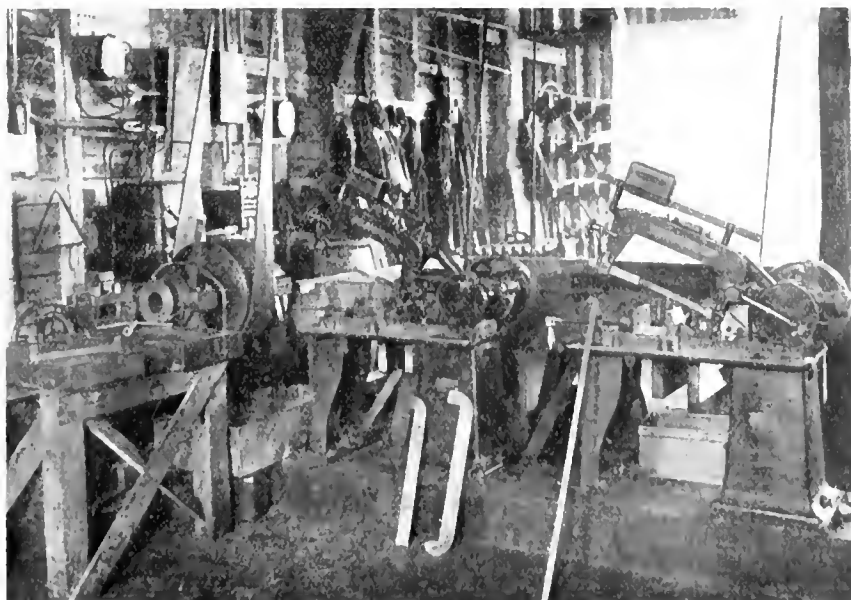

FIG. 1. SAWING AND PARTING BILLETS.

quite often, too hot to handle. The billet was held in a chuck which was machined from a piece of shafting, the chuck being fitted to the drill press spindle by the usual taper shank. A hollow-headed set screw locked the billet in place while adjustment for varying size of steel was obtained by four set screws located at 180 degs. from the locking screw.

The drill bar was of tool steel, $1\frac{3}{4}$ in. in diameter, and had two flutes milled in it for the egress of the chips. Two slots were also provided, into which were soldered brass pipes to carry the cutting compound. The lower end of the bar was secured to a flange bolted to the drill press table and carefully lined up with the spindle. The upper end was slotted to take the drill bit and a small pin was provided to hold it central. The bits were of high speed steel machined to shape and hardened and ground. The time taken to drill a hole was between seven and eight minutes. After being drilled, the fracture was faced off the base end. The machine used on this operation was similar to that for parting. Care was taken to see that a good surface was left on which to start the centering drill. A Rockford Lathe & Drill Press Co. sensitive drill was used for centering, a large cast iron table being substituted for the original small one because giving a better bearing for the swinging table which carried the centering post. The upper end of the centering post was ground to the same angle as the drill bit, thus centering the base end. The post, being a close fit for the hole, assisted in holding the billet true.

Rough Turning

Rough turning was done on the machine shown in Fig. 3, which is a 24-in. MacGregor, Gourlay lathe, fitted up with a roller chuck. Two tools were used, one at the back, held in a heavy cast iron holder, being of high speed steel, while the front tool was $\frac{1}{2}$ in. square stellite held in a No. 6 Efficiency holder, secured in the regular tool post. A jet of cutting compound was directed on each tool, that serving the back tool being made to point upwards and discharge on the work just before it reached the tool. The back tool holder was a fixture, and the tool was adjusted by setting it to a gauge. The size was made with the front tool, and was regulated by the cross feed. It was not necessary to set the tool for each shell, however, as, when the tool had reached the end of the shell, the lathe was stopped and the shell removed. The carriage was then run back and another shell put in. The lathe was next started up. This procedure was kept up until through wear the front tool required adjusting or grinding. The roller chuck shown in the illustration had three 7 16 in. hardened steel rollers working on a hardened cam. It gave excellent results and was very quick. The size made in the rough turning operation left about .03 in. of stock for the finish operation. The speed of the work was 96 revolutions per minute, giving a surface speed of 88 ft. per minute, figured

on the original diameter. The feed was 22 per inch. The actual time required to make a cut was 2 min. 20 sec., while it required 20 sec. to take a shell out and put in another.

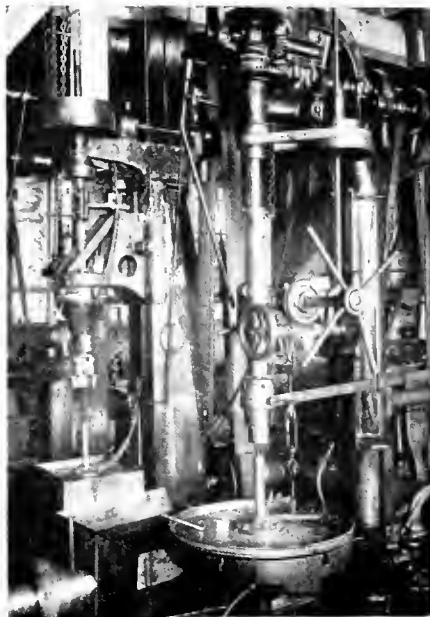

FIG. 2. INVERTED METHOD OF DRILLING

Rough Nosing

The next operation, rough nosing, was done on the special machine shown in the foreground in Fig. 4. It is similar to the other specials, except that the head was geared and the tools revolved while the work was held in a vise. Three forming cutters and a facing cutter were used, the latter to bring the shells to a standard length. As the work being done increases from a very light cut at first to a very heavy one when the facing off cutter got into action, a hand feed was adopted. The machine did excellent work, as many as 265 shells having been

put through in a shift. The rate of revolution was 34 per minute. The vise had one fixed and one movable jaw, the latter being fitted with four hardened insets, which had teeth cut in them to grip the shell.

Outside Finishing and Profiling

The outside finishing and profiling were done at one operation on an 18-in. American lathe, shown in the background in Fig. 4. The machine was fitted up with a profile bar and a roller 2 in. in diameter, kept in contact with it by means of a helical spring. The profile bar was mounted so as to be adjustable transversely. The cross slide screw, of course, was removed, the size being made by adjusting the compound rest. The same procedure to avoid changing the tool setting was adopted here as that used on the rough turn lathe. The tool, $\frac{1}{2}$ in. square high speed steel and sometimes stellite, was held in a block holder, adjustable longitudinally, in order to bring the profile in the correct location. The rate of revolution was 200 per minute, while a feed of 28 per inch was found to be satisfactory. To drive the shell, a three-jawed chuck gripping in the hole was used; it was operated by a hand wheel (late steering gear of a Ford car), working on a screwed rod passed through the headstock spindle. The hanging mallet was used to tap out the rod and expanding cone after slackening the wheel.

To assist in obtaining concentric bores, a rough boring machine was used. This was a special machine fitted with a collet chuck and a hand wheel for operating it. The tool was held in a bar carried in a travelling head, which was fed into the shell by a screw driven from the headstock spindle. A cone friction was used on the feed and the return was by hand.

Finishing Bore

Finishing the bore was done on two LeBlond lathes, one of which is shown in Fig. 5. The illustration shows three

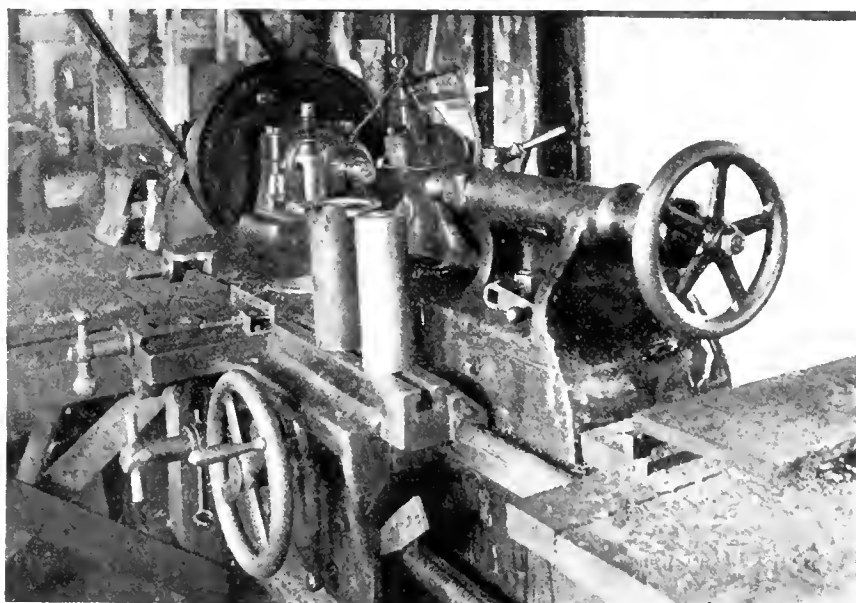

FIG. 3. ROUGH TURNING SHELL BODIES.

bars the one pointing to the shell was not, however, regularly used, it carried a point tool and was only employed if the rough boring machine was out of busi-

ness. The first cutter enlarged the hole to about 1.70 ins. in diameter and hogged out the bottom. The second cutter made the finish size and depth; as very little stock was left for this tool to take out a good finish was easily obtained. The lathes were both fitted with collet chucks having hand wheels for operating them. The turrets were very substantial, as can be seen from the illustration, a large bearing being provided for them to turn on. Cutting compound was fed through pipes let into the boring bars, and which communicated with the hollow turret stud to which the supply pipe was attached.

It may be mentioned here that all lathes on chucking operations were fitted with similar chucks, except the machine on the band recess. The chuck bodies were of cast iron, while the jaws were of chrome nickel steel. The jaws were operated by a nut, on the outside of which a hand wheel was keyed. The hand wheels proved to be great time savers. Cutting compound was fed to each machine by individual geared pumps, belt driven from any convenient revolving part. This method allowed of varying the compound to suit the particular work and was also useful when experimenting with new compounds.

Nose Operations

Boring out the nose of the shell, forming the nose, and undercutting for the fuse thread formed the next operation. It was carried out on a 16 in. MacGregor, Gourlay lathe, fitted with a turret secured to the saddle. The turret was of similar design to that used on the inside finish; but was a little smaller. The shell was located in the collet chuck by means of a cup fitting on the profile and secured in the turret, the method being

to place the shell in the chuck and tighten it slightly. The shell was then pressed home in the chuck by the cup, until the saddle came in contact with the stop.

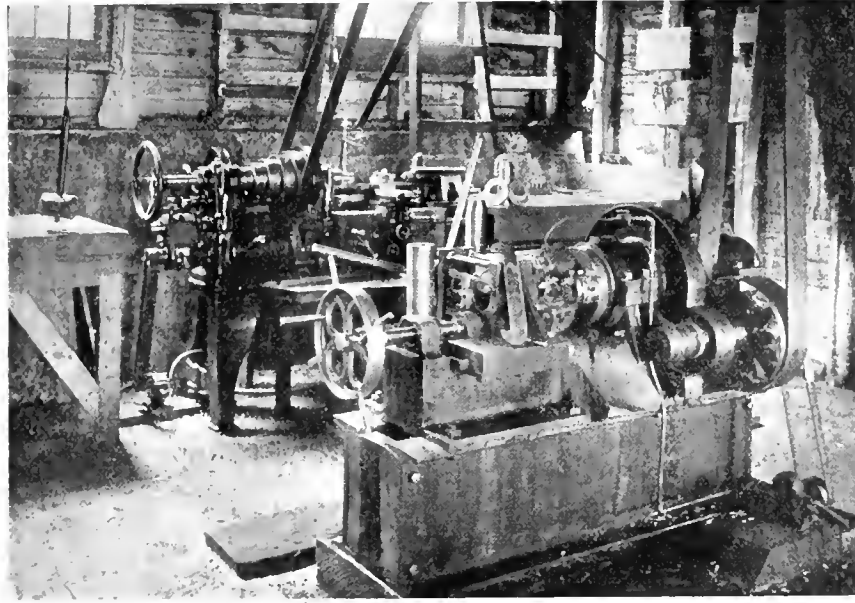

FIG. 4. ROUGH NOSING AND PROFILING

when the shell was firmly tightened. The shell was then correctly located in regard to the tools in the turret.

The fuse hole was first bored out with a point tool, the boring bar also carried the two bevelling tools required to finish the nose. Power feed was used until bevelling tools began to cut, when hand feeding was resorted to. The fuse hole undercut was put in with a tool mounted on a sleeve working on an eccentric bar. The tool was formed to make the undercut and also to slightly round off the under shoulder. A small bevelling tool was also mounted in this holder and was used to bevel the mouth of the hole to prevent a rag being set up when milling the thread.

Copper Band Recess

The band recess was put in on a 16-inch C.M.C. lathe, fitted with a special attachment in place of the cross slide. The shell was held in a three jaw Cushman chuck and was located by a stop striking the bottom of the hole, the base of the shell being carried on the tail stock centre. The special attachment was fitted up with four tools. The first, a roughing out tool, was carried in a holder under the shell and was brought into action by drawing the attachment toward the front. As the tool passed the centre, it finished its cut and brought the attachment up against a stop which located it correctly for the two undercutting tools carried inverted in a block at the back. The undercutting tools were held in blocks fitting into slides planed to the angle of the undercut. They were fed to the work by one revolution of an eccentric spindle, and returned by springs.

To form the waved ribs, the attachment was run back against a stop, bringing the cam and roller into engagement, causing the ribbing tool to reciprocate. The ribbing tool was fed in by hand against a stop giving the correct size. Fig. 6 is a view of the machine showing the attachment. The work turned out was exceptionally good and there was no difficulty in getting the rated capacity.

Finishing Base Recess

A 16-inch Le Blond lathe was used to finish the base recess, it having been previously hogged out on either one of the inside finish lathes, or on the rectification lathe, which was always available. The tools used on the recess were mounted on a square turret built on the cross slide of the lathe. The bottom of the recess was first faced off, just enough stock being left from the hogging operation to make a true and smooth finish with one cut. As the facing tool passed the centre and ceased to cut, a forming tool came into opera-

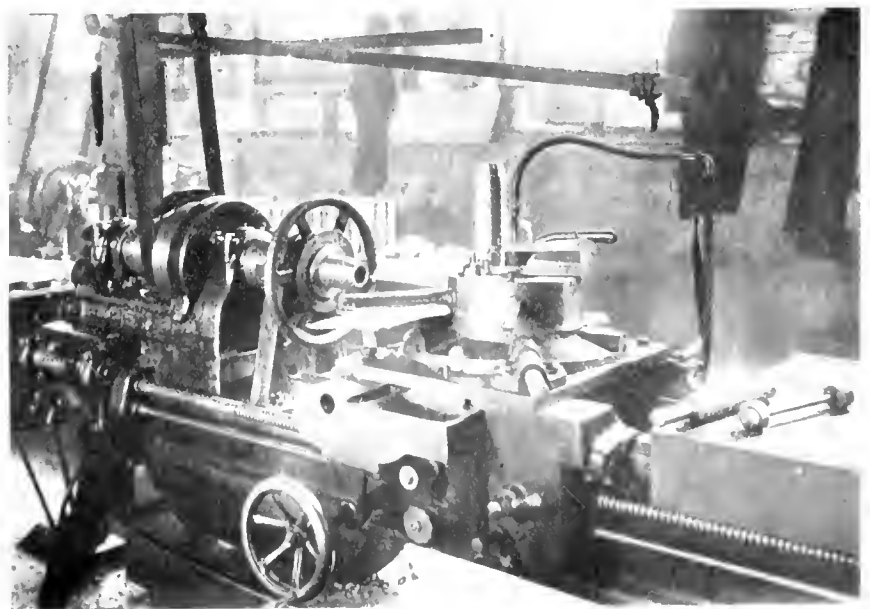

FIG. 5. INSIDE FINISHING OPERATION.

tion and put a small radius on the base end of the shell. This radius was put on for the benefit of the thread miller. It will be noticed that no work other

tion will be omitted. After being milled the fuse hole was sized with a hand tap.

Tapping Out Base Recess

The base was tapped out on a Hoeffler

subjected to a complete shop inspection, rectifications being made on a Boye & Emmes lathe, fitted with various convenient tools and attachments, before the shells were submitted to the Munitions Board Examiners.

After passing the preliminary examination, the base plates were screwed into the shells. The base plates were machined on a 14 in. Sebastian lathe fitted with a turret on the cross slide and a screw cutting dial on the saddle. The chuck gripped the shank of the base plate and was tightened by means of a couple of cap screws. The diameter and face were first roughed off, the same tool being used for both operations. The diameter was then turned down to size with a wide tool having a projecting lip for putting a slight bevel on the face to prevent the formation of a rag. The threading tool holder carried a small wheel which, when it touched the face, located the threading tool in the correct place. Three or four cuts with the threading tool were found to be sufficient. The face of the base plate was next finished off with a flat tool set to give the required .002 in. of camber.

After the base plates were screwed in, the square shank was cut off in a hack saw. The saw had a very short stroke and two shells were put in at once, thus using up all of the blade. As previously mentioned, the blades used on the operation were those discarded at the machines cutting up the billets.

Facing Off Base to Weight

Facing off the base to weight was done on a machine built up on the bed of the rough turn lathe which was amply long enough to accommodate the two operations. The projecting portion of the base plate and a slight amount of the shell was first faced off. A side cutting tool was used which had a notch ground in it to follow a ridge at the seam. The ridge was then rolled in by three small rollers carried in a sliding block and forced against the work by the tail stock screw. The base was afterwards faced off again to remove the mark made by the rolls.



Compressed air is obtained on a large scale without employing either steam or motor-driven or other moving machinery at a copper mine in Michigan, where about 82 per cent. of the actual power of the falling water through tubes is transformed to compressed air under a pressure of 118 lb. The air is delivered to the hoisting engine, the stamp-mill power units, and to the mine proper practically dry and at the temperature of the water. The system is almost automatic, and as there are few moving parts, the upkeep is very low. Water for compression purposes is taken from the Ontonagon River, and after passing through the system is returned to it at a point about one mile down-stream. Automatic regulation is obtained by utilising the air pressure built up in the compressor chamber. Excessive air pressure is automatically relieved by means of an escape pipe running from the air chamber to the surface.

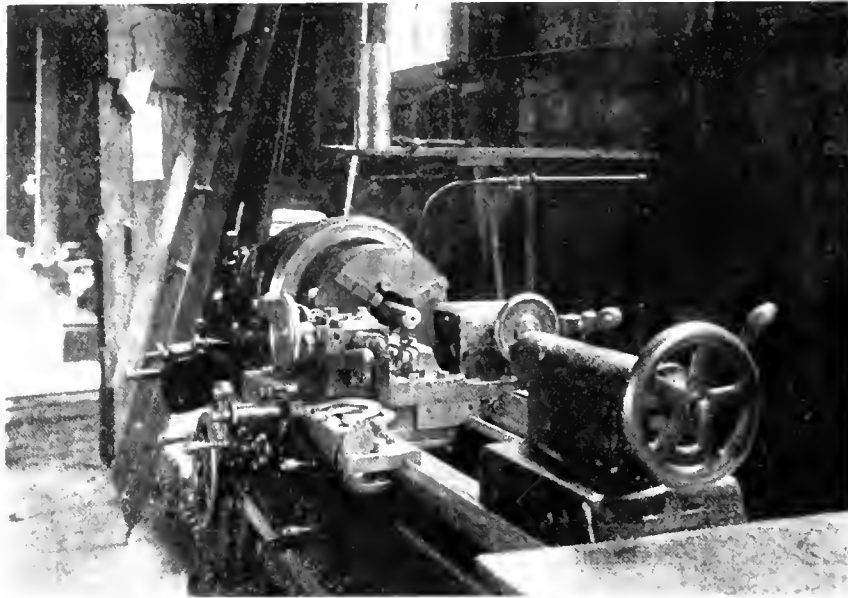

FIG. 6. COPPER BAND RECESSING EQUIPMENT.

than to remove the fracture has been done on the base of the shell. The radius, being true with the shell, assists in centralising the work in the miller. The turret was then swung a half turn, and the recess reamed to size with a flat reamer. Two sizes were made, one for the thread and one for the counterbore. The same side of the turret carried an undercutting tool by which an undercut was put in below the part to be threaded. The machine and tools used on the base recess are shown in Fig. 7, the unit being run on the open belt at a speed of 140 revolutions per minute.

A Holden Morgan thread miller was used to thread the fuse hole. These machines are so well known that a descrip-

Mfg. Co., 24 in. drill press, using a solid tap. The shell was held in a vise which was allowed to float on the drill press table. The tap was held in a friction holder secured to the spindle and tightened only sufficiently to drive it. A forward and reverse drive was obtained by means of an open and a crossed belt driving pulleys with a friction clutch between them. The tap, which had 10 lands 3-16 in. wide, was started into the work by the hand feed lever. Provided care was taken that not too much stock was left in the hole to be tapped, very good threads were obtained, and the operation was very quick, 350 to 375 being an ordinary eleven hours output. The shells were next thoroughly cleaned and

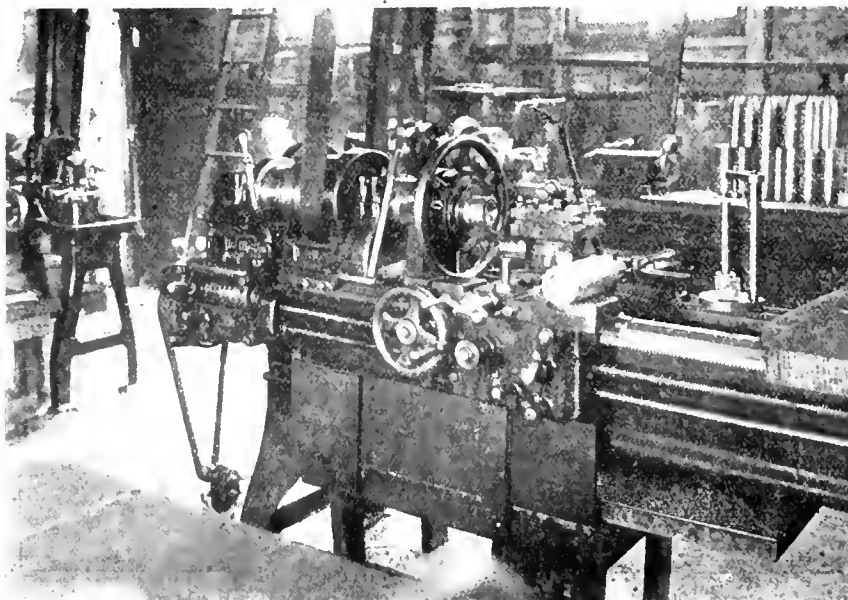

FIG. 7. BASE RECESSING OPERATION.

PRODUCTION METHODS AND DEVICES

A Department for the Interchange and Distribution of Shop and Office Data and Ideas Evolved from Actual Practical Application and Experience

INTERESTING WAVE AND GROOVE MACHINE

By R. Hamilton.

MANY interesting and ingenious devices have been designed and constructed for the operation of grooving and cutting the waved ribs on the various types and sizes of shells. The wide range of practical experience that the mechanical world has been able to put into the "game" of manufacturing munitions of war has resulted in the development of innumerable methods and attachments for the accomplishment of the many different machining operations involved in their production. Plant executives in all parts of the Dominion have, in many respects, been forced to rely upon their own resources for the success of this industry, and too much credit cannot be given those men, who through their inventive genius, have done so much in the development of suitable facilities as to make the manufacture of shells more rapid and certain.

When it is understood that the specifications call for specific results, and when on first thought it might appear that the objective could only be obtained in one or possibly a few ways, it is, to say the least, remarkable, when we learn in course that the operation is being performed in perhaps more than a score of ways, showing the different channels through which the mind of man will run

in the manufacture of shells is that of cutting the groove for the copper bands. The feature that makes this particular operation so interesting is the oscillation that is required of the tool when the waved ribs are being formed. Many methods have been adopted for the achievement of this object, the principal one now in use being that of placing a suitable cam on the face-plate for the lateral movement of the tool. The cutting tool in the majority of cases, remains stationary in relation to the axis of the shell, with the exception of its lateral and forward movement. This naturally necessitates slightly more clearance on the tools owing to their tendency to rub upon the sides of the ribs. The design of the machine illustrated was advanced for the purpose of eliminating this factor and at the same time making the entire unit practically automatic, and while the mechanism has the appearance of being rather complicated, this "grasshopper" as it is called is an extremely efficient machine.

The driving pulley A is of the friction clutch type, being operated by the pneumatic cylinder B. The pinion C, keyed to the driving shaft, meshes with the larger gear D, which in turn is secured to the main spindle, the front end being provided with the collet chuck E, which is operated by the application of air in the cylinder F, located on the rear end of the spindle. Between the main bearings and integral with the spindle is the large single pitch worm G, meshing with the worm gear, directly below, on the cross shaft H, the outer end of this shaft carrying the hand wheel I, for hand manipulation. At either end of the shaft H, a small pinion is secured that drives the gears J, one of these being on each side of the machine. These gears are provided with a small crank that converts the circular motion of the shaft into a reciprocating one, the medium being the rods K on either side. The opposite end of these rods carries the cams that furnish the feed to the tools; the two at the back, LL, operating the undercutting tools, these being held in the two slides NN, set one above the other end at the proper angle to the axis of the shell. The cam M at the front of the machine is for the feed of the wav-

ing tool. This tool is held in the forward end of a bell crank block O, the trunnion of which fits in the tool slide, lateral play being taken up by the two lock nuts P. The outer end of the bell crank O is provided with a slot in which the small crank block is free to move. This small block fits over the crank that is turned on the end of the shaft S, the latter being driven by means of the bevel gears T and U, these in turn being secured to the end of the primary driving shaft. When the driving clutch is in, the "grasshopper" is jumping, but the feed, or the movement of the cams, can be stopped by disconnecting the worm gear from the driving worm G.

The operation is as follows: The shell is placed in the chuck and gauged to position by lowering the gauge X and turning on the air to operate the pneumatic chuck F. The lever V is then raised, and the machine commences its automatic operation. The ratio of the driving pinion to that of the main gear provides the proper oscillations for the cutting tool. With the machine running, the crank on the end of the shaft S causes a rocking motion to the bell crank O. This is one of the principal features of the complete mechanism, as the tool is always maintained in a position at right angles to the direction of the waved rib. As the shell is revolved, the cranks on either end of the shaft H slowly turn, causing the cams to move slowly back and forth, thus feeding the tools into the work. This machine has been in constant use for two years in the plant of the Jenckes Machine Co., and has given complete satisfaction.



NICKING OF SHELL NOSES

By J. H. R.

TO simplify the details of machining operations and at the same time speed up the assembling of the various sizes of shells, changes in the specifications have been made from time to time, the fulfilment of which has often necessitated new methods to achieve the desired result. One of the changes instituted during the past year has been the method of securing the fuse to fixed position after it has been screwed into place. Formerly, this was accomplished by means of small headless screws passing through the nose of the shell or socket and bearing against the thread of the fuse body. The general practice on the latest type of shell is to lock the fuse in position by burring down three points on the outer edge of the fuse platform into corresponding grooves cut at an angle in the outer edge of the shell nose bevel. This objective has been attained in different ways dependent on the initiative of the shop executives and the resources of plant equipment. The accompanying sketch shows a device constructed and used by I. Matheson & Co., of New Glasgow, N.S., and is giving very

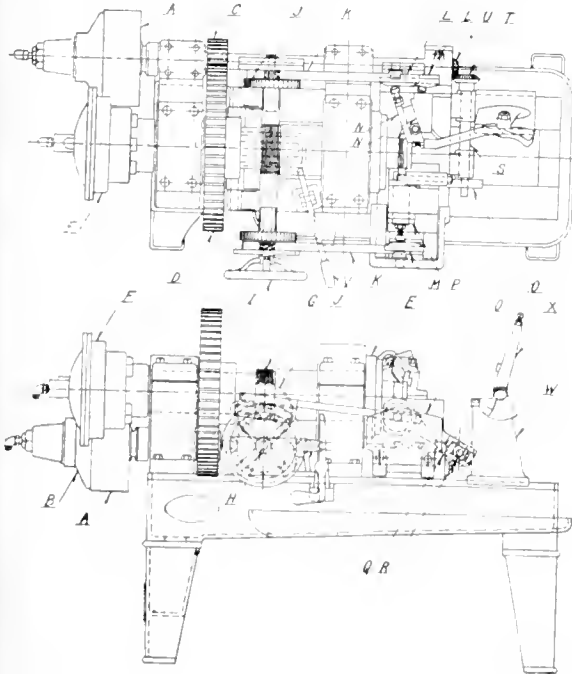

INTERESTING WAVE AND GROOVE MACHINE.

even when the same identical result is required. The operation that has probably been given greater attention than any other in connection with the manu-

facture of shells is that of cutting the groove for the copper bands. The feature that makes this particular operation so interesting is the oscillation that is required of the tool when the waved ribs are being formed. Many methods have been adopted for the achievement of this object, the principal one now in use being that of placing a suitable cam on the face-plate for the lateral movement of the tool. The cutting tool in the majority of cases, remains stationary in relation to the axis of the shell, with the exception of its lateral and forward movement. This naturally necessitates slightly more clearance on the tools owing to their tendency to rub upon the sides of the ribs. The design of the machine illustrated was advanced for the purpose of eliminating this factor and at the same time making the entire unit practically automatic, and while the mechanism has the appearance of being rather complicated, this "grasshopper" as it is called is an extremely efficient machine.

good satisfaction. The fixture is a unit in itself, being operated from a counter-shaft overhead. The base A, which forms the chuck for holding the shell, is firmly

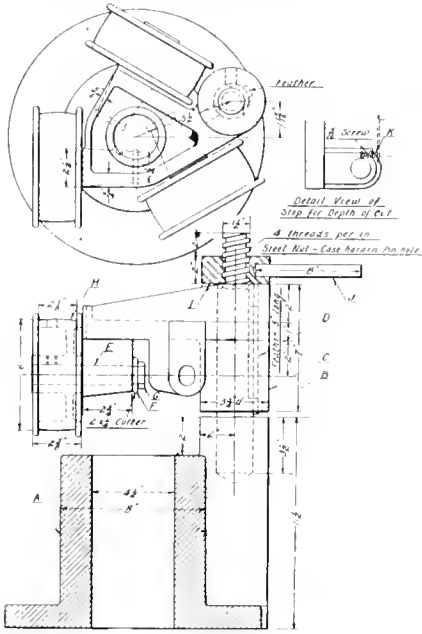

NICKING SHELL NOSES.

secured to the bench, and from a boss at the back, the shaft B extends perpendicularly. Mounted on this shaft is the housing casting C that furnishes the bearings for the three cutter shafts E. To retain the three cutters in their relative position to the axis of the shell when the latter is held in the chuck, the shaft B is fitted with a feather D, permitting vertical but no horizontal movement. On the inner end of each cutter shaft is a small cutter F, which is retained in position by the nut G. These cutter shafts are driven by the small pulleys H, fitted to the outer end, the belts passing across an overhead shaft. When the shells are

secured in position in the chuck, the three cutters are fed simultaneously into the nose through forcing down the housing C by revolving the nut I, which acts upon the coarse pitch screw at the top of the shaft B. A short rod J is provided for the convenience of operating this nut. The detail to the right of the illustration shows the small screw used for adjusting the depth of the cut and the point that it strikes on the nose of the shell.

A similar arrangement has been designed and constructed by the Lachine Manufacturing Co., the method of operation varying a little from that shown in the accompanying sketch. The horseshoe piece A, which is fitted to the table of the fixture, gauges the location of the shell in a central position and has a vertical movement to feed the cutters into the work. The housing B is rigidly secured to the column C, and above this is secured another arm D that supports the clamping shaft E, the vertical movement of which is controlled by the stop pin shown at the front. The large spring keeps the lower end of the clamp shaft pressed over the nose of the shell, thus holding it firmly while the cutters are being fed into the work. When in the position shown, the nose of the shell is free from the cutters, so that when the shell is pushed upwards, the nose is brought into contact with the clamp before the cutters begin to cut. Small guide pulleys F are provided to assist in keeping the belts in place.

movement of the saddle containing the cutting tools is obtained by the pinion operating in the rack fitted to the bed of the machine. While moving the saddle along to the desired position, the stock is roughed from the stick by the tool B secured to the front of the steady rest. By pulling on the lever fitted to the

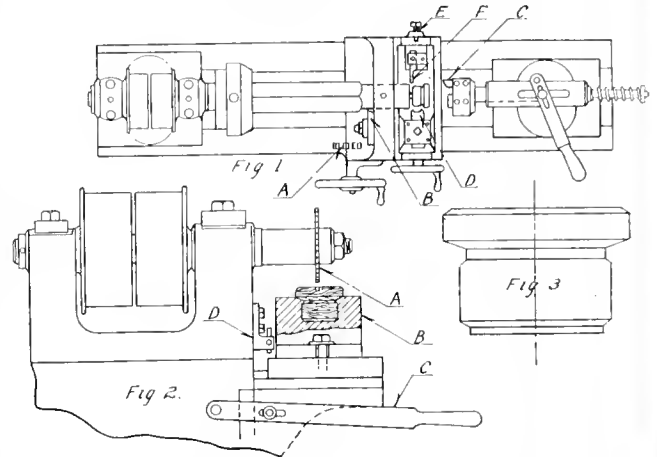

MACHINING WOOD FUSE PLUGS.

tailstock spindle, the cutter head containing the tools C is advanced to the work and the end faced and chamfered. The tool D located on the front of the cross slide is then forced in, and the body of the plug formed; this operation completes the sizing of the threaded portion, angle of seat and undercut, the movement being regulated by the stop E. The plug being fully turned, it is then cut off with the tool F. The slotting of the upper end is performed in the machine shown in Fig. 2, the cutter A being held in a suitable arbor which is attached to the spindle of the machine. This cutter is 3/16 inch thick and 4 inches in diameter. The turned plug is placed in the cast iron block B, it being made a snug fit for the wooden plug. By lifting the lever C, the work is ad-

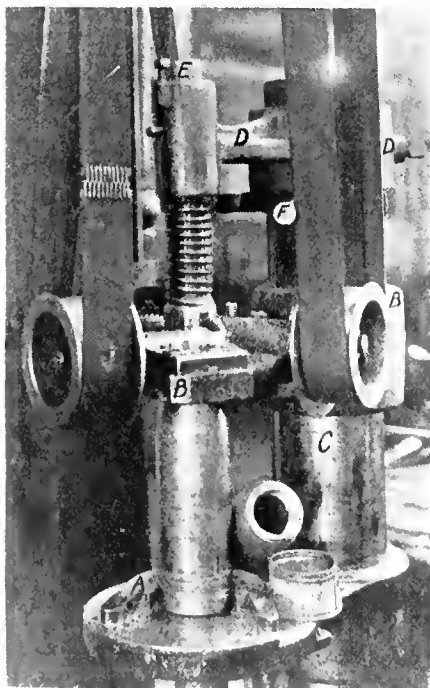

NICKING SHELL NOSES.

MACHINING WOOD FUSE PLUGS

By S. B.

TO protect the noses of the shell from injury while they are being transported from one place to another, dummy plugs are placed in the threaded end; these plugs may be made from metal or wood, as their duty is only a temporary one. The line drawings herewith illustrate a special attachment for the manufacture of these wooden plugs. Fig. 1 shows the fixture used for turning the plugs from the stick. The timber is first dressed and cut into lengths 2% square; one end is then turned to 2 1/2 inches diameter so as to enter the hole in the steady head attached to the saddle. The lateral

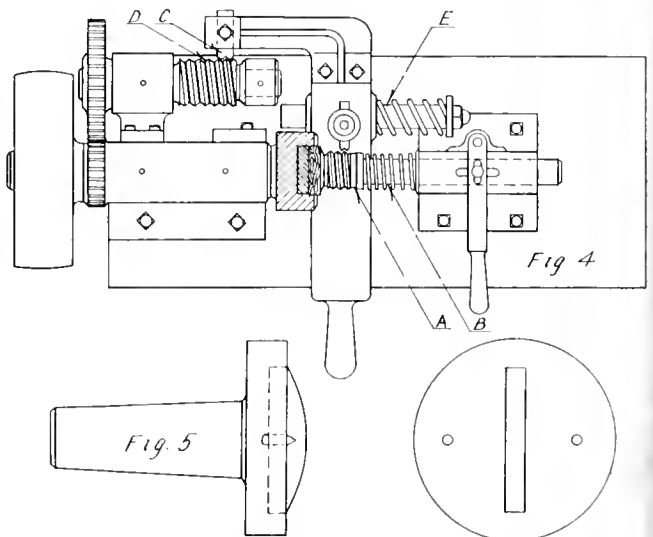

MACHINING WOOD FUSE PLUGS.

vanced to the cutter, the depth being governed by the adjustable stop located in the bracket D. Fig. 3 shows the plug ready for slotting. The machine used for threading the plugs is illustrated in Fig.

4. The plug is placed in the chuck, the driver having a projection to fit the slot in the end of the plug. It is held in position by the cup centre A which is kept forced against the end of the plug by the action of the spring fitted about the tailstock spindle B. The sketch Fig. 5 gives a clearer idea of the driving plug. By pressing down on the large handle the back end is tilted up bringing the form C in contact with the guide thread D, this latter being fitted to the auxiliary spindle at the rear of the machine. The spring on the rod E is for the purpose of returning the cutter bar to its original position after the thread has been cut.



STAYBOLT RIVETING KINK

By S. W.

THE sketch shows an arrangement whereby the blows of a pneumatic riveter are distributed around the head of a

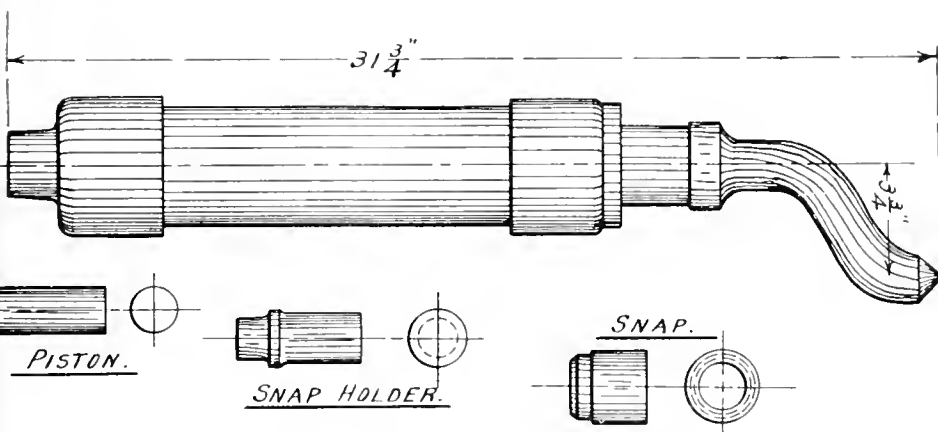

STAYBOLT RIVETING KINK MECHANISM.

staybolt or rivet, being riveted up in such a manner that the edges are caulked tightly down to the plate. The crank end is inserted in place of the straight centre and, as the riveting proceeds, the whole gun is rotated by the operator.



ENGINEERS AND OTHER MUNITION WORK IN THE FIELD.

AN interesting paper was read recently by C. G. Barber before the Junior Institution of Engineering on "Engineering and Other Muniton Work in the Field." He said that the workshops at the Front for the repair of equipment which may require attention, either through wear or through the effect of hostile fire, has, during this crisis, become a very important factor, because, wherever a repair can be effected at the seat of activity, considerable advantage is gained. As far as possible the most urgent repairs, such as gun and gun carriage repairs, are carried out within a few miles of the sphere of action, while some of the minor, though not unimportant, repairs are effected on the spot. It, however, falls to the lot of the base workshops to deal with the majority of repairs, and it is such that are specially referred to here. The workshops may probably employ two or three thousand hands, the major-

ity of whom are men of H.M. Forces, and the remainder women of the town wherever the workshop chances to be pitched.

Workshop Site.

The site of the workshop, in the first place, has to be carefully chosen, with a view to speedy erection and also economy in erection. In this case an old mill was chosen, having some very useful machinery, and also most of the buildings which would be required for the different workshops. Further power being required as time advanced, was obtained by the erection of one or two engine sets of about 20 h.p. Perhaps the most important of all was the receiving department, by whom everything from the Front is taken and dispatched either to the incinerator, England, or the workshops for repair, according to the condition of the article. The unloading by the department from the trucks on the sidings is done by the French women, who are

supervised by a few soldiers. In all probability these women will, for this work, will be replaced by black labor before very long.

Machine, Carpenter and Wheelers Shop

The fitting and machine shop presents nothing of very special interest, or, at least, only on some occasions, such as when carrying out some special scheme of conversion or modification to conform to suggested improvements on guns or their carriages. With few exceptions all guns and carriages which cannot be repaired up country (a few miles behind the lines), are sent home to England.

In the carpenters' and wheelers' shop all vehicles are repaired. Perhaps the most trying duties in this shop are the repair of civilian wagons, which had previously been bought by the military from farmers, when the need for such was greater than it is now. An average of forty to fifty vehicles are repaired in this shop weekly. Wheels, being standardized, are dealt with separately. The spokes and felloes are supplied from home ready cut, thus expediting the repairs. An average of 400 are repaired weekly. When the accumulation of those awaiting repairs grows above about 2,000, say, 1,000 are dispatched to England for repair.

Smoke Helmet Repair Department.

The smoke helmet repair department is responsible for the periodical re-dipping of the smoke helmets, which is done in specially prepared solution. Each soldier is provided with two of these helmets, one in reserve, it being the duty of the C.O. to arrange for a periodical inspection to satisfy himself that they are still effective against the poison gas. It is easy to decide. Within a few miles of the firing line it is a breach of military law to be about without one of these helmets. About 50,000 of these helmets are received from the Front weekly for re-dipping and repair as may be necessary. The eyepieces and mouth-pieces are first removed; the helmets are then washed in hot water to remove all impurities. They are then placed in centrifugal hydro-extractor to remove the excess of water, and afterwards hung in a drying cupboard, steam heated to about 180 degrees F. When sufficiently dry they are examined and repaired where necessary. Following upon this they are passed to the re-dipping plant, which is under the control of a chemical expert, who is himself responsible for the preparation of the solution in which they are dipped. The helmets are dipped and then passed through a mangle to extract the excess of solution. They are then ready for the final drying cupboard. The effect of this process is more to permeate the solution into the pores of the helmet than to dry it, and in reality the helmet leaves this cupboard in quite a moist condition. They are then ready for the assembling room where the mouthpieces and eyepieces are replaced, after which they are placed in wallets of waterproof cloth, and are then ready for dispatch to the units. The daily output of these helmets is about 6,000.

Mackintosh Cape Department

The Mackintosh cape department is responsible for the repair of capes and also ground sheets. I have sometimes seen the ground sheets being prepared for a patch the size of a dinner plate, which is applied exactly the same as a patch to a punctured cycle tire. About 6,000 of the mackintosh capes are dealt with in the course of a month, and nearly half of these are found to be beyond repair, and in some cases certainly look as though they had been in an explosion. These hopeless cases—or capes—are passed to the tent-mending department, where, including the repair of all tents, tarpaulins, etc., these old capes are cut up and utilized for the manufacture of wallets for smoke helmets, and also covers for steel shrapnel helmets.

The smoke helmets which are put aside as being beyond repair are also sent to this department, where they are cut up. Referring to the steel helmet covers, many are covered with this waterproof cloth; but, on the other hand, another favorite method of making them khaki is to paint them, and while quite wet sprinkle them with sand. This provides them with a very serviceable covering, and is more largely adopted where they are used in sandy districts.

—Practical Engineer.

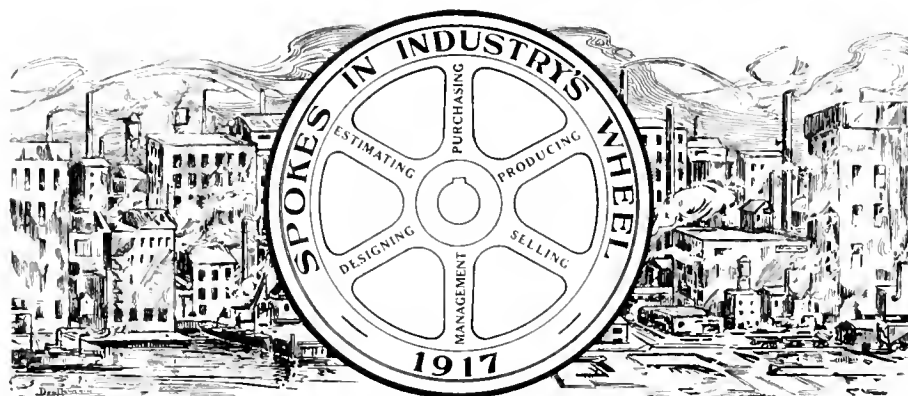

The constitution of industrial enterprise is largely departmental—"spokes in a wheel." This series of articles has for its object the featuring in a racy, interesting and instructive fashion, the training, experience and achievement of those who to-day are transmitting, effectively, energy in their capacity as "spokes in the wheels" of our metal-working establishments.

GEORGE CHADWICK GREGSON

ON the seaward side of the hammer-shaped peninsula, forming part of the district of Furness, between the estuary of the Duddon and Morecambe Bay, where a narrow channel intervenes between the mainland and the long low Island of Walney, is the small but thriving town of Barrow-in-Furness. This sea town is noted for its modern and remarkable growth during the past century. The growth has been dependent primarily upon the existence of veins of pure haematite iron ore in the adjacent district. Early in the nineteenth century, mining operations were in progress, and the subsequent development was so rapid that the export of ore in 1847 amounted to 50,000 tons per year, the town at that time having a population of about 325. Some few years later, large iron works were erected, to be followed shortly thereafter by other industries. The location being a highly desirable one for shipbuilding purposes this industry soon surpassed all others, and now occupies the foremost place in the town's activities. The yard of the celebrated firm of Vickers, Ltd., is located here, and from the human element of this plant our "Spoke" for this issue received his training.

Education and Apprenticeship

George Chadwick Gregson, superintendent of the munitions department, Canadian Vickers, Ltd., Montreal, was born in Barrow-in-Furness, Lancashire, England, on December 10, 1886; his father being Robert Gregson, master mariner, and his mother Georgina Agnes Chadwick. Having come from a long line of sea-going ancestors on his father's side, it was the early ambition of our "Spoke" to cast his lot upon the briny deep, but a combination of circumstances willed it otherwise. George received his boyhood education at the High Grade School, Barrow-in-Furness, and at the age of fifteen started his apprenticeship with Vickers, Sons and Maxim, naval constructors, in the gun mounting department. The first three years were divided be-

tween bench, marking-off tables, tool and jig drawing office, and assembling of heavy guns on ships, the last two years being spent on the machines, principally lathes. Much of the success of our youthful "Spoke" is attributed to instruction given at the excellent local technical school in which the firm took special interest, encouraging the boys in every way to attend regularly. Boys who did well at the night school had their hours of work shortened, were granted bonuses, and, if so inclined, were given positions in the draughting offices.

Old Country Apprenticeship Practice

Boys of to-day apparently do not realize the difficulties contingent to the ser-



GEORGE CHADWICK GREGSON

ving of an apprenticeship in British industries, and probably would not relish the early hours of rising, that is the general practice in that country. Living some distance from the works and being required to start at 6 a.m., it was ne-

cessary that our "Spoke" should "get up" at five in the morning to answer "roll call"; and to his credit be it said, that he was not late more than half a dozen times during the five years of his apprenticeship. In addition to this, George was a regular attendant at night school, two to three nights a week, acquiring the fundamental essentials in steam, machine construction and drawing, mechanics and mathematics, in order to establish himself in the theory of his practical accomplishments.

Promotion Rapid

Honest effort is always rewarded, and a few weeks after the completion of his apprenticeship, the subject of our sketch was called into the office of Mr. Fender, works superintendent, and asked if he would like to go on his rate-paying and efficiency staff. This new departure was to the liking of our "Spoke," and for six months he was estimating and fixing prices in the Field Carriage Department, following which he was promoted to be assistant foreman in the same department. Realizing his abilities, the management transferred him to the shipyard, where for twelve months he was engaged in fixing prices and looking after costs on all ship fittings. Similar positions were filled in the Marine Engine Department, fixing prices on all classes of machinery; the same duties in the large turbine erecting pits, and at the same time looking after the cylinder and shafting shops. During his sojourn in this latter department, the engines of the large battle cruisers, Lion and Princess Royal, were under construction, these consisting of turbines developing 75,000 horse-power; also those for the Japanese battle cruiser, Kongo, of 80,000 rated horse-power. Trouble having arisen in connection with the maintenance of the heavy oil engine department, our "Spoke" received instructions to establish order there, as a result of which he gained further new and interesting experience. During the seven years that followed his apprenticeship, he covered all the machining and assembling sections of the works, which at that time was employing from 18,000 to 20,000 men, and which has justly earned the reputation of having the most satisfactory and complete cost and process system in the world; that is, for a plant of its size and character. A constant source of inspiration to the members of the rate fixing staff was the opportunity given to study the editorial contents of various trade and technical periodicals, the firm supplying these, as a result of which tool and jig design were in many cases materially influenced.

Accepts Position in Canada

While still in the heavy oil engine department, our "Spoke" was approached by the Ingersoll-Rand Co., of Sherbrooke, Que., with a view to accepting a position to assist in establishing a planning and efficiency department. Negotiations being satisfactorily arranged, G. C. G. came to Canada in the spring of 1913 and spent two pleasant and instructive years, the experience gained being of inestim-

able value. In March of 1915, our "Spoke" again returned to Vickers' employ, this time, however, to the Canadian plant at Montreal, P.Q. At this time the manufacture of munitions was occupying the attention of many Canadian industries, and our "Spoke" was given the position of superintendent of a shell shop which was just being inaugurated. Much of the success of Canadian Vickers, Ltd., during the past two years of shell activity can be credited to the untiring efforts and executive ability of Mr. Gregson, although he admits that he has thought, many a time, that his friends would be visiting him in Verdun. (There is a place there where the guards do your thinking, and entertainment is supplied by the Government.)

Travel, Recreation, and Social Side

Whether G. C. G. is a believer in the adage that "A Rolling Stone Gathers no Moss," is not known, but at any rate his traveling has been confined to a few trips to the States on the lookout for machinery. However, the call of his forefathers is still heard, and during his summer holidays, particularly before coming to Canada, he spent his recreation periods upon the deep blue sea. He remembers with pleasure that a few years back he used to pack his "sea bag," go over to Fleetwood, and ask some trawler skipper if he would take a passenger, the answer generally being favorable to our "sailor's" ambition. Many a two weeks were spent in this way, either on the South Coast of Ireland or to the lonely rock of Rockwell, on the West Coast of Scotland. Being an Englishman, G. C. G. is also passionately fond of walking, and in pursuit of pleasure he has walked over many portions of England, Ireland and Wales.

Early in 1914, eleven months after his arrival in Sherbrooke, P.Q., Mr. Gregson married Mary Constance Vernon, youngest daughter of Mr. and Mrs. J. W. Vernon, of London street, Sherbrooke. George's wife is a Canadian, and a great booster for this country, her mother's name being Bliss, and one of an old Eastern Townships family. The present residence of our "Spoke" is at No. 22 Third Ave., Montreal, about three minutes' walk from the plant; this feature during the past two years proving especially handy when it is necessary to be called to the works at all hours of the day and night.

Views on Technical Study

In religion, Mr. Gregson is an Anglican, and in politics (English), was a Liberal; but the strenuous times of the past few years has given little opportunity to declare himself in this country. Mr. Gregson, when time permits, uses his recreation hours in cricket, football, tennis, and fishing.

Speaking of the advantages of technical study on the part of young mechanics, Mr. Gregson says: "In my opinion, the technical papers have, and are, playing a very important part in the development of the modern machine shop; in their pages one sees all that is new; you

are brought into contact with what is going on in other shops throughout the country. Many and many a time we have just got the idea we wanted by running through a bundle of technical papers in search of a simple jig, or inexpensive and quick production tool. The idea of a jig and tool designing office without these journals is too ridiculous to think of. If the young mechanic of to-day has any ambition outside of being just a good mechanic, he has simply got to study, and study hard. These are days of keen competition, and the man who has a little more knowledge than his fellow, and the ability to use it, is the one to gather the plums."

BRITAIN'S ORE AND PIG IRON SUPPLY

DISCUSSING Great Britain's supplies of iron ore and pig iron, also the shipping situation in general, Premier Lloyd George said:—"We are melting millions of tons every year of iron ore, and we cannot cut down the supply by a single ton. It is essential for the munitions of war, essential for shipbuilding, and essential for the machinery required in agricultural work. Therefore, we must find ships for this work at all costs. There is plenty of ore in the country, but its quality is not too good, and it has not paid to dig it. It has been cheaper to get the better class of ore from Spain.

"This, however, is not a commercial question. It is a question of getting ore, and getting it without using up our shipping tonnage. It involves, unfortunately, the increasing of our number of blast furnaces. That means more labor for building and carrying on the work, and there is a very limited supply; in fact, there is no margin of supply of highly skilled men to work these blast furnaces. We have protected them against recruiting for months, but in spite of that fact, we are short of the necessary supply of labor for our blast furnaces.

"There are mines in Lincolnshire, in Cumberland, and there are the famous Cleveland mines, all producing excellent ore; and if we could increase the labor in those mines we could augment by millions of tons a year the quantity of ore which can be produced at home. Here, again, you require skilled as well as unskilled labor. I want to make a special appeal to both classes. There are a certain number of mines which might be able to spare a few miners for this purpose. In those two directions we might be able to secure the necessary number of skilled men, and for the unskilled men we must trust the people to place their services at the disposal of Neville Chamberlain for the purpose of assisting in this all-important task."

As to the supply of pig iron, the secretary of the Cleveland Blastfurnacemen's Association stated some time ago that during the past six months six additional furnaces have been put into operation in the Cleveland district, which should mean an increase of between 1,000 and 5,000 tons of pig iron weekly. The work at the seventy-six furnaces now in blast is

being carried on with the minimum number of men. Before additional furnaces could be put to work the skilled men necessary must be relieved from military service.

The Barrow Steel Co. has had a furnace waiting for several weeks to be put into operation, and the Askam Ironworks is ready to start when a regular supply of ore is assured.

PRESERVE FIELD PRODUCTS FROM LOSS BY FIRE

THE fire waste of the Province of Ontario for the first three months of 1917 as shown by reports to the Fire Marshal, amounts to \$3,321,931. In 1916 it amounted in round figures to \$12,000,000, and if the waste is not stopped, the year 1917 threatens to be as disastrous as its predecessor. The unfortunate part of the whole matter is that the waste comes largely from the destruction of field products in barns, elevators, and warehouses, or in canning factories, cereal mills, and other places where the raw product is being turned into food for our own needs and for the armies of the Allies. It is equally true that many fires, probably one half of them, could be avoided by a little care and thought. Surely, as a people we should be ready and willing to take up this Empire call and preserve what we produce.

By way of example, reference is made to barn fires. Last year, in Ontario alone, over 600 barns were destroyed, involving a loss of more than one million dollars, of which six hundred thousand dollars was on produce, implements, and live stock. If by a little care we can save one half this loss we should be doing the equivalent of that much extra production, and who is there among us who is not prepared to do his "bit" on this line? Three very simple suggestions are thrown out which if adopted will go a long way to accomplish the result:—

1.—Install lighting rods on barns and save fires from lightning. The Department of Agriculture, Parliament Buildings, Toronto, will furnish any one with a pamphlet showing how the rods should be made and erected. It is an absolute fact that barns properly rodged and grounded are not liable to be struck by lightning.

2.—The crops should not be put in until it is certain they have been properly cured. Evidence is daily accumulating that the heavy clover crops of last year did not receive full and proper care and resulted in the firing of barns from spontaneous combustion. Many doubt this theory but recognition of the cause is growing very rapidly.

3.—Ventilate the barn so that gases caused by the fermentation of imperfectly cured crops will be successfully carried off. In an unventilated barn to keep the doors and windows closed after harvest, and then admit air by the opening of the doors, windows, or other apertures during the warm fall weather is to invite the fire fiend to get in his work.

EDITORIAL CORRESPONDENCE

Embracing the Further Discussion of Previously Published Articles, Inquiries for General Information, Observations and Suggestions—Your Co-operation is Invited

MACHINISTS' INSTRUCTION COURSE—XX.

By J. Davies.

THE most common cutter used in milling machines is the plain miller, sometimes called cylindrical. It is simply a plain, round cutter with teeth cut straight across,

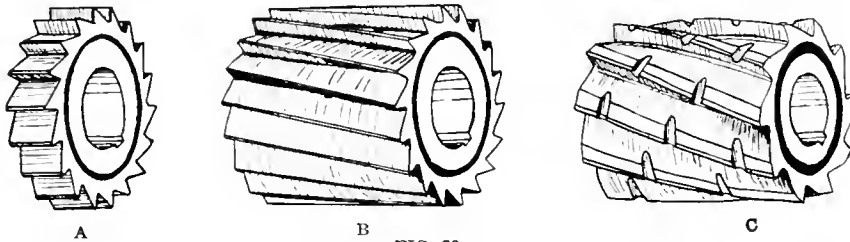

FIG. 72.

see A, Fig. 72; it is a cheap cutter to make and answers very well for milling narrow surfaces. It is not very suitable for milling wide surfaces, however, because the full length of the cutting edge comes in contact with the work at one time. This has led to the construction of milling cutters with helical teeth, see B, Fig. 72. In a cutter of this kind the cut commences at one end of the cutting edge and gradually works across the full width, which prolongs the life of the cutter, makes a smooth job, and takes less power to drive.

Far very heavy milling on extra wide surfaces, a cutter with helical teeth is used, the teeth being so nicked that a cutting edge comes behind each nick so that it does not affect the finished surface. The nicking of the teeth causes the chip to be broken up, enabling a heavier cut to be taken than would be possible with the ordinary milling cutter, see C, Fig. 72.

Inserted Tooth Cutters.

Owing to the high cost of tool steel, every benefit that can be obtained by the use of inserted teeth, or built-up cutters, ought to be taken advantage of. Not only is the saving due to the reduced

sults in hardening. There is quite a variety of designs of inserted teeth milling cutters, some people preferring one kind and some another. Three typical designs are shown in Fig. 73. In A, the body is made preferably of machinery steel, although wrought iron or even cast iron is sometimes used. The har-

dened tool steel teeth are held in place by taper plates or bushings and screws, and can thus be easily adjusted or removed. The bushings, screws and teeth are interchangeable. The second, B, differs from the first only in the method of securing the inserted blades. A hole is drilled between every blade and reamed out taper to suit a standard taper pin, and after reaming, slots are cut through the reamed holes. The taper pins are driven into the holes expanding the metal, which secures the blades very effectually. The third type, C, is another variation of the same idea, only in this case taper dovetailed keys are fitted into the slots milled to receive them. This makes a particularly solid cutter, and by tapering the ends of the blades and fixing them to project past the body of the cutter a good side-cutting miller can be made.

For milling tee-slots and dovetails, a solid end mill is generally used with a taper shank which is driven tight into

possible, or, if not, drive with a piece of hard wood. In any case be sure that the taper of the shank fits the spindle and that it is driven home good and snug.

Holding and Setting Cutters.

In some milling attachments extra precautions are taken to keep the end mills from coming loose. Sometimes they are drilled and tapped at the end to receive the spindle and are thus kept in place; or perhaps a taper pin passes right through, or a safety set-screw. No matter how it is done, be sure to keep it tight. If being used on a repetition job, it is an easy matter to make some sort of a jig or fixture to hold the work; in like manner, special cutters are made for nearly every conceivable kind of a job.

Setting the cutters is a problem that is worth some consideration. It is not often that a cutter can be set for depth by direct measurement, and the guess

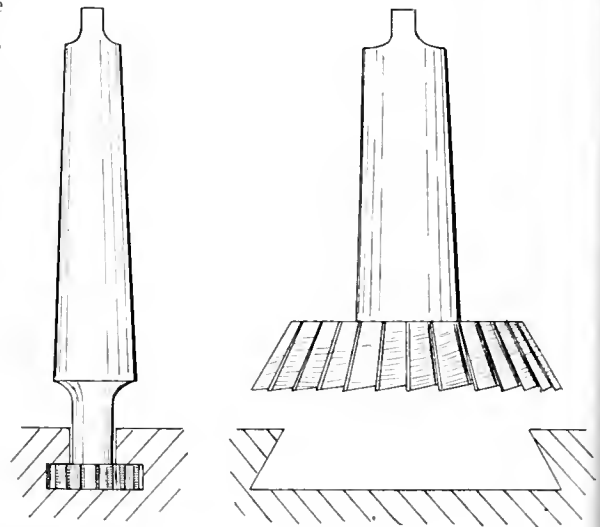

FIG. 74.

and try method is very unsatisfactory. The most practical method is by using the indicator dials attached to the feed screws, which are usually graduated in thousandths.

When setting the cutter by use of the graduations, bring the work and cutter together close to each other, and start up the machine, in case the cutter may not be turning perfectly true, as a cutter that is not running true will cut deeper than a true one of the same diameter, if set to the same mark. Bring the work up to the cutter until it just touches, and be sure that all the lost motion, or back lash, as it is also called, is taken out of the feed screw before the cutter touches the work.

When the cutter is just touching the work, a reading of the indicator is taken, and the work run clear of the cutter.

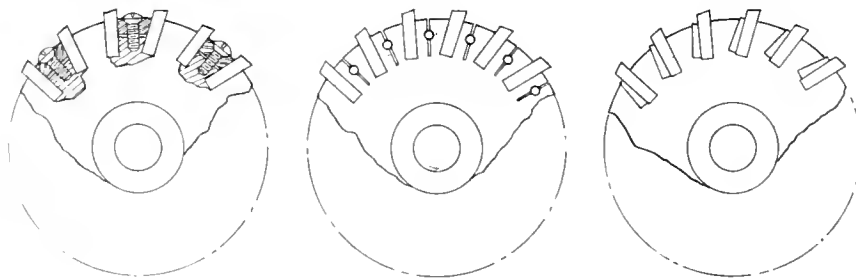

FIG. 73.

cost of the steel, but also in the convenience of manufacture and handling, replacing of broken teeth, and better re-

the spindle of the machine. See Fig. 74. In driving, care must be taken not to break the teeth; use a lead hammer, if

Add the amount equal to the depth of the cut required and set the machine accordingly.

If the nature of the work will permit the trying of a gauge or testing with micrometers, test as soon as enough finished surface is milled to permit of doing so. It will be found that in most cases a little more will have to be taken off on account of the spring of work and cutter. The graduations are very useful at this stage, as the table can be raised just the amount required as found out by careful measurement.

Setting the Cutter Sideways.

Here again the graduations on the feed screw can be used to advantage in setting the cutter to cut at any given distance from the edge of work held in

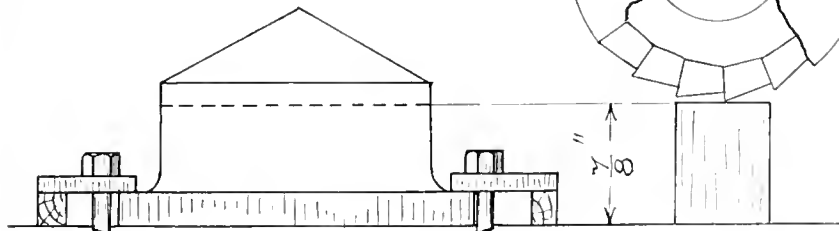

FIG. 75.

Use of Tool-Setting Blocks.

In some cases a measurement must be taken at a given distance from the base as shown in Fig. 75. The tool-setting blocks as used on the planer can be used on a job like this. Then again bring the work and cutter together until the cutter is just touching. If it is found that the cutter is not running perfectly true, stop the machine with the tooth of the cutter that touches the work next to the table, run the cutter clear of the work and raise the table high enough to take out all lost motion. Now lower until the gauge just touches the cutter as it passes underneath. Always stop the machine when setting the cutter this way, as milling machine cutters are no respecters of fingers.

An adjustable gauge can easily be made for this class of work and set to the required size by micrometers. If you have no tooth-setting gauge and do not think it worth while to make one, one can be made in a few minutes by taking a piece of $\frac{1}{2}$ -sq. stock cut off with a hack-saw and ground to size—a pair of inside calipers can be used, or else a surface gauge. In using calipers, find the shortest possible measurement between the cutter and the table, and adjust to size. If the machine has no graduated dial or indicator, and you have to make a cut of a given depth, the small adjustable tool-setting block shown in Fig. 76, is very useful in setting up the cutter as just described. Run the cutter clear of the work, adjust the gauge block to just touch the cutter. Measure with calipers or micrometer, deduct the amount of cut required and reset the cutter to the gauge block. A very short adjustable gauge is all that is necessary as parallel blocks can be used to make up the height.

The milling machine differs from the lathe and planer, inasmuch as the work on the miller in most cases must be set correctly before the cut is put on, or the job may be spoiled.

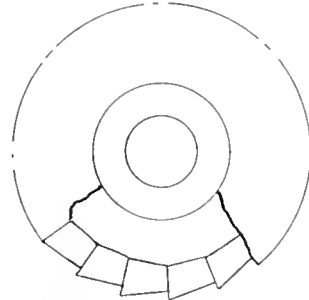

the distance to the centre of the vise. If there is any lost motion in the screw, take it out before counting the graduations either way, or else caliper with a pair of inside calipers equal distances from both sides of the cutter to vise jaws, when cutter will be in centre



CALCULATING THE WEIGHT OF A FLYWHEEL

By D. A. Hampson.

THE weight of a flywheel needed for a machine which does all of its "work" during only a portion of its cycle can be determined by well-known formulae if certain assumptions are made and if the work can be expressed in foot-pounds. The most familiar machines requiring flywheels to balance work of this sort are punches and presses for sheet metal working. With these the work is done during a portion—say from one-tenth to one-half of the downward stroke; the remainder and all of the upward or return stroke are idle movements, simply overcoming the friction of the machine. As the belt is constantly running, it is the function of the flywheel to store up enough energy during the idle portion to overcome the resistance of the working portion of each revolution.

The first step in the calculations is to put that resistance in terms of foot-pounds; then to find just what is the proportion of idle to useful time. This is usually a matter of measurement and is reduced to degrees about the flywheel centre, for instance—20 degrees working, 340 degrees idle. If the number of revolutions per minute of the flywheel is known, this is again reduced and expressed as "seconds working," "seconds idle." If the speed is not known, one must be assumed for calculating purposes.

There must also be known, or assumed, the reduction in speed which the flywheel makes during the working period. This is an important factor and in the case of a new machine must be assumed, basing the assumption on experience and judgment—it is commonly stated as "per cent. loss in speed while actually

the vise. If the work stands up above the top of the vise, place the edge of the cutter against the edge of the work, note the graduations and move

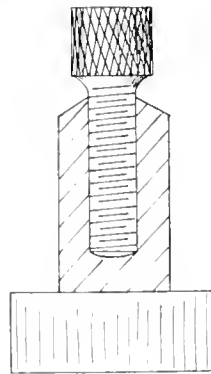

FIG. 76.

the work over the amount required, being sure to take into consideration the thickness of the cutter. See Fig. 77, left.

If the work is below the vise, or if there is room at the end of the vise, bring the cutter up against one side of the

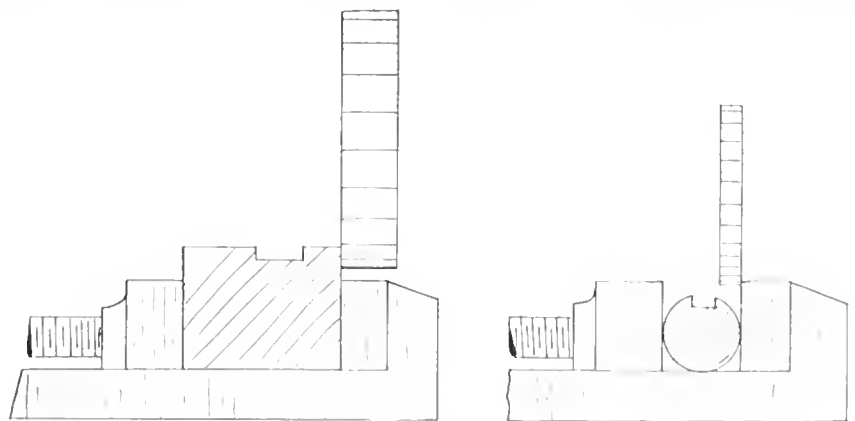

FIG. 77.

vise, Fig. 77, right, and run it over to the other side, noting the distance on the indicator. Then bring it back half

cutting." In the case of cutting, say a thin sheet of brass the loss will be perhaps only 5 per cent. or less; if the

length of the cut in the direction of the stroke is considerable, the loss may run high, perhaps 25 per cent.

Example of Application

Paper cutting machines are fine examples of the case where the length of the cut is a major part of the stroke. The vertical travel of the cutting knife may be 5 in. and for this size of machine the capacity would be at least 4½ in. of paper. This is many times the proportion found in machines for stamping sheet metal and furnishes a very interesting example for flywheel design. It is obvious that either a very heavy flywheel must be provided or else there will be a big reduction in speed when cutting, for if the wheel is not heavy enough, the machine will run slower and slower as the knife cuts downward and may even stop if the flywheel cannot give up en-

The constant in the denominator of (3) varies from .000002 for 2¼ per cent. loss to 000015 for 20 per cent. loss.

Formula (1) is not necessary to the flywheel calculation but gives an idea of the work to be done and the sizes of belt or motor needed. After the weight is found, the section of the rim necessary is a matter of adjusting width and thickness to other conditions. The entire calculation is free from complication and answers for all simple cases.



THE METRIC SYSTEM AND POST-WAR DEVELOPMENT

By J. Hardie.

IN view of the possibility of extended inter-continental commerce between countries and Canada, it will probably be necessary for the industrial

posed to take as a unit of measurement the length of a pendulum, beating one second, at sea level, at a latitude of 45 degrees. Nothing definite was accomplished, however, until the year 1790, when the National Assembly appointed a commission to investigate the advisability of establishing a system of measurements, based on the theory of Picard. The decision of the commission was in favor of using as a base the quadrant of the terrestrial meridian, but it was not until 1799, after nine years of investigation and calculation, that the length of the metre became a fixed value. The new system became "compulsory" in 1801. Other systems were still in use in many parts of France, and in an effort to extend the adoption of the National system it was necessary to pass a law in 1837, forbidding the use of any other weights

LINEAR MEASURE ENGLISH TO METRIC.												
In.	Ft.	Yds.	Rds.	Fur.	Mls.	mm.	cm.	dm.	m.	Dm.	Hm.	Km.
1						25.4	2.54	.254	.0254			
12	1					304.8	30.48	3.048	.3048			
36	3	1				914.4	91.44	9.144	.9144			
198	16.5	5.5	1			5029.2	502.92	50.292	5.0292			
7920	880	293.3	40	1		201168	20116.8	2011.68	201.168	20.1168	2.0117	
63360	5280	1760	320	8	1	1609344	160934.4	16093.44	1609.344	160.9344	16.0934	1.609

ergy enough to carry past the lowest point. A special paper cutter, built on much the same lines as an open side punch press, furnished a problem which the following calculations successfully solved: The data determined and assumed were as follows:—

1,050 lbs. pressure required back of the knife to do the cutting.

3 in.=stroke of press.

2 in.=1/6 ft.=length of cut in direction of stroke.

60 rev. per min.=60 cutting strokes per min.

Cut=110 deg. or .3 sec., idle=250 deg. or .7 sec.

18 in.=1½ ft.=mean diameter of fly-wheel rim.

Total energy required for the cutting stroke=1050×6=175 ft. lbs.

The following formulae are now applied.

$$\text{ft. lbs. reqd.} \times \text{rev. per mm.} =$$

$$(1) \text{ H. P.} = \frac{33,000}{175 \times 60} = 32.$$

$$(2) \text{ E}_1 = \text{ft. lbs. reqd.} \times \left(1 - \frac{\text{sec. of actual cut}}{\text{total time of stroke}}\right) =$$

$$175 \left(1 - \frac{.3}{.7}\right) = 122\frac{1}{2} \text{ ft. lbs.}$$

$$(3) \text{ Wt.} = \frac{\text{constant} \times \text{dia.}^2 \times \text{rev. per min}^2}{122\frac{1}{2}} = 1281.$$

$$.0000118 \times 1.5^2 \times 60^2 =$$

world to become better acquainted with the standards of measurement now in use in European and South American countries—namely, the metric system. This system is based on the theory of the metre being 1-ten millionth of the quadrant of the earth's surface, on a line passing through Dunkirk. The unit of volume is a cube measuring 1-10th of a metre on a side, and is termed a litre, while the gram is the unit of weight and is nominally 1-1,000th of the weight of a litre of water at 4 degrees Centigrade, or 32.9 degrees F.

The origin of the system dates back to the seventeenth century, when the French astronomer, Jean Picard, pro-

posed to take as a unit of measurement the length of a pendulum, beating one second, at sea level, at a latitude of 45 degrees.

Legalized in Many Countries

The metric system is now obligatory in the following countries:—Argentina, Austria-Hungary, Belgium, Brazil, Chile, France, Germany, Greece, Italy, Mexico, Netherlands, Norway, Peru, Portugal, Roumania, Servia, Spain, Sweden, and Switzerland. Its use is legalized in Egypt, Great Britain, Japan, Russia, Turkey, and the United States. In England, several attempts have been made to have this system supersede that at present in vogue, but without success. However, in 1897 certain concessions were

LINEAR MEASURE METRIC TO ENGLISH.										
mm.	cm.	dm.	m.	Dm.	Hm.	Km.	In.	Ft.	Yds.	Mls.
1							.03937			
10	1						.3937			
100	10	1					3.937	.3281		
1000	100	10	1				39.37	3.2808		
10000	1000	100	10	1			393.7	32.808	10.936	
100000	10000	1000	100	10	1		3937	328.08	109.36	
1000000	100000	10000	1000	100	10	1	39370	3280.8	1093.6	.621

LINEAR CONVERSION CONSTANTS.			
Inches	x	25.4	= Millimeters (mm)
Feet	x	.3048	= Meters. (m)
Yards	x	.9144	= Meters.
Rods	x	5.0292	= Meters.
Miles	x	1.609	= Kilometers (Km)
Millimeters	x	.03937	= Inches.
Meters	x	39.37	= Inches.
Meters	x	3.281	= Feet.
Meters	x	1.0936	= Yards.
Kilometers	x	.6215	= Miles.

granted and a statute was passed, the Weights and Measures (Metric System) Act, legalizing the use in trade, of the metric system, and abolishing the

parently not yet developed sufficient advantages to justify its general adoption; even by those countries whose Governments have made it a penal offence to

activity, the fundamental principles of any system of measurements is to weigh and measure, not calculate. Nevertheless, in view of new developments that will undoubtedly arise at the termination of the war, a clearer understanding as to the comparative values of the British and metric system may be of inestimable value in the near future, and to assist readers in this matter, the accompanying tables and conversion constants have been prepared:

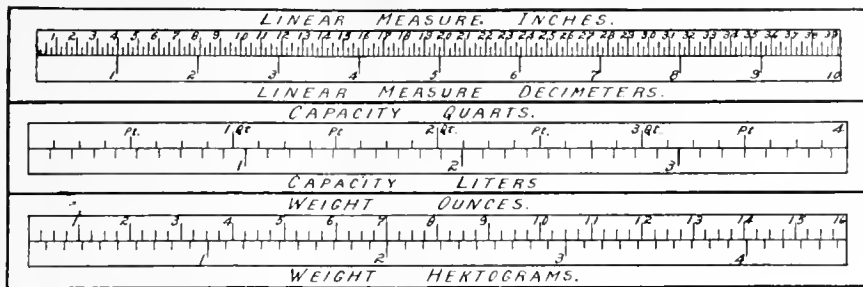

penalty for using or having in one's possession, a weight or measure of that system. The metric system was legalized in the United States in 1866 and the recognized value of the meter is 39.27 inches.

However, despite the efforts of the many foreign countries to suppress all other forms of measurements, it is an unquestionable fact that the metric system has not entirely supplanted those methods previously in use; on the contrary, while the metric system is generally recognized as the official Government standard, certain industries and merchants continue to designate in lignes (0.089 inch) and inches all the articles they sell. Many countries in Western Europe "sell" their product by the metric system, but make use of the old system in the process of manufacture. In France and Belgium manufacturers of silk fabrics make exclusive use of the Aune (1.312 yards) and the Denaro (18.17 grains) as the units of length and weight respectively. In Germany, the cotton industry is based on the British yard and pound, and the woollen industry on the old German ell (27.08 inches) and pound. Throughout the metric and non-metric world, lumber is sawn by the inch.

With the above facts in mind, it would appear that the metric system has ap-

use any other system. The advocated feature of the system seems to be the convenience of reduction or conversion of the units, due to its decimal divisions. The importance of this factor, however,

Derivation of Nomenclature

Multiples in the metric system of measurement are derived by prefixing the Greek words deka (10), hekto (100), and kilo (1,000). Divisions are obtained by prefixing the Latin words deci (1/10), centi (1/100), and milli (1/1000). The measurements of surfaces (areas other than land) and volumes are obtained by squaring or cubing the values in the

MEASURES OF WEIGHT ENGLISH TO METRIC											
gr.	oz.	lbs.	cwt.	tons.	mg.	cg.	dg.	g.	Dg.	Kg.	Ton.
1					64.8	6.48	.648	.0648			
437.5	1							28.35	2.835	.02835	
7000	16	1						453.6	45.36	.4536	
		112	1							50.8	
			20	1 (L)						1016	1.016
		2000		1 (S)						907.2	.9072

CAPACITY CONVERSION CONSTANTS.			
Gills (gi.)	x .118	= liters. (l)	Milliliters (ml) x .0085 = gills.
Pints (pts.)	x .472	= liters.	Liters x 2.12 = pints.
Quarts (qts.)	x .944	= liters.	Liters x 1.06 = quarts.
Gallons	x 3.776	= liters.	Liters x .265 = gal.
			Hektoliters x 2.84 = bu. (dry)

is lost in the knowledge that such conversion, for practical purposes, is very infrequently used. In the everyday requirements of industrial and commercial

linear table, similar to the English method; for instance, a square centimetre would be 10mm. x 10mm equals 100 sq. mm., a square metre would be 10dm. x 10dm. equals 100 sq. dm. The same principle is applied to volume; thus, 10dm. x 10dm. x dm. equals 1000 cu. dm. equals 1 cu. m. In the measurement of capacity the litre is the unit, and is equivalent to the volume occupied by one cubic decimetre; the corresponding English value being 3.937 x 3.937 x 3.937 equals 61.023 cu. in. nearly. The U. S. gallon contains 231 cu. in.; therefore, the litre is approximately .265 of a gallon, or 2 1/4 pints.

The accompanying tables, together with the chart and conversion constants, provide a convenient reference to compare the relative values of the metric and English systems. To illustrate the value of the conversion tables, take for example, to translate the expression \$1 per foot into francs per metre. One dollar per foot would be \$1 multiplied by 3.281 equals \$3.281 per metre, as the franc (19 cents) is the unit of the monetary system in France, also the adjacent countries of Belgium and Switzerland. the French value would be 328.1 divided by 19, equalling 17.26 francs per metre.

WEIGHT CONVERSION CONSTANTS.			
Grains (gr.)	x .0648	= grams (g)	Grams x 15.4 = grains.
Ounces (oz)	x 28.35	= grams	Grams x .0352 = ounces
Pounds (lbs)	x 453.6	= Kilograms (Kg)	Kilograms x 2.2 = pounds
Tons (long)	x 1.016	= Tons (metric)	Metric tons x .9842 = tons (L)
Tons (short)	x .9072	= Tons (metric)	Metric tons x 1.1023 = tons (S)

MEASURES OF WEIGHT METRIC TO ENGLISH											
mg.	cg.	dg.	g	Dg	Hg	Kg.	t.	gr.	oz.	lbs.	cwt. (L) T
1								.0154			
10	1							.154			
100	10	1						1.54			
1000	100	10	1					15.4	.0352		
10000	1000	100	10	1				154	.352		
		1000	100	10	1			1540	3.52	.22	
		10000	1000	100	10	1		15400	35.2	2.2	
						1000	1			19.68	.9842

Similarly, at \$1.50 per pound the relative French value would be \$1.50 multiplied by .4536 divided by 19, or 3.58 francs per kilograms. At \$2.25 per gallon, the

No form of deep mining can be prosecuted without coal, and the absence of coal will effectually limit the mining of all metals and minerals. Coal moreover

are a menace only, if coal is absent. In these times coal spells power. It is a necessity of nationhood.

Is it therefore too much to say that if Canada wishes to fulfil the glorious promise of her future she must guard as a precious jewel that remote Island which saw the dawning of British power and British ideals on this Continent, and stands not only as a sentinel over the broad and ancient commercial highway of the St. Lawrence, but is Canada's chief treasure house and depository of coal, a substance greater in potentialities than all the silver of Cobalt, or all the gold of Porcupine and Yukon.

As the principal British naval base in North Atlantic waters, Halifax will always retain its pre-eminence, and it only needed the actual stress of warfare to restore to this Canadian port the lustre that had become dimmed by a long period of peace. It is an ice-free port, lending itself admirably to fortification and submarine defences, and its railway connections would be difficult for a hostile landing force to interfere with so far as the immediate hinterland is concerned. Of the two lines of railway that connect Halifax with Quebec and Montreal, one parallels the St. Lawrence river so closely as to be quite open to attack from the river, and the lower gulf. The capture of Halifax by hostile forces would not so seriously impair our national defences as would the hostile occupation of Cape Breton Island. Those who have followed the course of events at Zeebrugge, on the Belgian coast, will realize what the Bras d'Or Lakes could be made as a submarine base if they fell into the hands of an enemy, and the analogy between the Dardanelles and the Straits of Canso must have struck every military observer who has ever passed through the narrow channel dominated by the imposing bulk of Cape Porcupine.

MEASURES OF CAPACITY METRIC TO ENGLISH									
ml.	cl.	dl.	l.	Dl.	gi.	pts.	qts.	gal.	
1					.0085				
10	1				.085				
100	10	1			.85				
1000	100	10	1		8.5	2.12	1.06		
10000	1000	100	10	1	85	21.2	10.6	2.65	

MEASURES OF CAPACITY ENGLISH TO METRIC.							
gi.	pts.	qts.	gal.	ml.	cl.	dl.	l.
1				118	11.8	1.18	.118
4	1					4.72	.472
8	2	1				9.44	.944
32	8	4	1				3.776

French equivalent would be \$2.25 multiplied by 3.776 divided by 19, or 44.7 francs per litre.



STRATEGIC VALUE OF CAPE BRETON ISLAND*

By F. W. Gray**

WHEN the French monarchs of the old regime selected Louisburg as the site of an impregnable fortress, proudly named the "Dunkirk of America," they had a proper conception of the strategic importance of the ISLE ROYALE, that outpost of Canada since known as Cape Breton Island. Who holds the Island of Cape Breton commands the Cabot Straits and the Gulf of St. Lawrence, and if that same power holds also the island of Newfoundland, the Gulf of St. Lawrence can be made a closed sea.

While the main ideas of naval strategy are the same in all times, yet to-day we think in terms of modern inventions. The advantages given to Cape Breton Island by its geographical positions are at this date enhanced by the presence of large bodies of coal developed to a producing stage, by the existence of large iron and steel works and chemical plants, and by the existence in connection with these industries of commodious harbors, equipped with facilities for loading and discharging cargoes, and by rail connection with the mainland.

The Coal Factor

It may be laid down as an axiom that no modern nation can retain economic independence unless it possesses within its frontiers a supply of bituminous coal. Bituminous coal is the motive power of modern civilization. It has been truly said—and by a German military leader—that victory in the present war will go to the nation that can mine and carbonize the largest quantity of bituminous coal.

is the source of the base of the most destructive modern explosives. Briefly, without coal the national armament would be limited to the weapons of the mediaeval knight. As this war and its preliminaries have abundantly demonstrated, economic dependence spells sooner or later political subservience.

The importance of Cape Breton Island is chiefly this: With the exception of a strictly limited deposit of bituminous coal on the mainland of Nova Scotia, the Island of Cape Breton and the submarine territory adjacent, contains the only supply of bituminous coal in Canada east of the region of Weyburn and Estevan.

Coal Spells Power

The national future of Canada, its maintenance of national integrity and political independence, is bound up with retention of possession of the coalfields of Cape Breton Island. This may seem a sweeping statement, originating in the mind of one who attaches undue importance to coal, but a little consideration of the present position of France, Italy, Switzerland, Norway, Sweden, Spain, Greece, and—to come nearer home—of Central Canada, will show that the statement is made advisedly. France and Italy would be impotent and defeated if it were not for the coalfields of Britain and the British Navy.

The position of the European neutrals to-day is dictated by the source of their coal supply. The safety of the United States lies not so much in vast territory and population as in the possession of the richest coalfields of the world, so situated as to be far removed from the danger of foreign invasion. If Russia were not the possessor of coalfields she would be more helpless than Holland, more dependent than Denmark, because, and here is where the analogy interests Canadians, extent of territory, density of population and agricultural wealth

are a menace only, if coal is absent. In these times coal spells power. It is a necessity of nationhood.

Comparative Strategic Value

Imagine a geographical position which combines the strategic value of the Dardanelles and Gibraltar with the industrial importance of Pittsburg or Sheffield, and one has a fair and not exaggerated conception of what Cape Breton Island means to Canada, and conversely, one may deduce what nature the menace would assume were this island in enemy hands.

The potentialities of Cape Breton Island for defence or for offence in the hands of a resourceful foe, are less or greater according to the smaller or larger concentration of industrial activities in the island, and the time seems to have arrived when the Government of Canada must take this matter under consideration in all that bears on the future of industrial expansion in Cape Breton.

Take for example the suitability of Sydney Harbor for a shipbuilding plant. The advantages of this site are too obvious to necessitate their being set out in detail; the thing is self evident. A large ship-building industry in Sydney, with the provision of the dry-dock that would be a natural and necessary accompani-

*Paper read at recent annual meeting of Mining Society of Nova Scotia.

**Asst. to Gen. Mgr. Dominion Steel Corporation, Sydney, N.S.

ment, connotes at once adequate military and naval protection. Otherwise it will be foolish to multiply and concentrate still additional facilities in Cape Breton Island that would advantage an enemy in control of the island.



ANNUAL MEETING OF MINING SOCIETY OF NOVA SCOTIA

THE twenty-fifth annual meeting of the Mining Society of Nova Scotia was held at the Sydney headquarters on April 19, and was attended by about seventy-five members. The morning was occupied by a visit to the works of the Dominion Iron & Steel Co., in which the whole process of steel manufacture was followed from the ore-bins to the finished product. In the afternoon the business of the society and the reading of papers was proceeded with. The report of the treasurer showed a satisfactory condition of the society's finances. The officers of the society for 1917 were elected as follows, the election of the president, vice-president and secretary-treasurer being by acclamation:

President, Hon. Col. D. H. McDougall; vice-president, Hon. Col. Thomas Cantley; secretary-treasurer, E. C. Hanrahan; associate-secretary, E. A. Saunders.

Members of Council: F. J. Sexton, T. J. Brown, J. R. McIsaac, Hon. Robt. Drummond, F. E. Lucas, H. B. Gillis, Alex. McEachren, G. D. MacDougall, Malcolm Beaton, W. H. Graham, Malcolm Blue, F. W. Gray, C. M. Odell, John Casey, R. E. Chambers, Isaac Greenwell, John Johnson. The list of papers presented is as follows:

John Casey—"Safety and Mine Discipline."

W. H. Graham—"Some Notes on the Advantages of Efficient Coal Washing as Reflected in the Manufacture of Iron and Steel."

F. W. Gray—"The Strategic Value of Cape Breton Island, With Especial Reference to the Coal Fields."

Vincent McFadden—"A proposal for the Complete Electrification of the Industries and Transportation of Cape Breton Island."

Geo. D. MacDougall—"Modern Steel Plant Economics."

C. M. Odell—Title to be announced.

Robert Robertson—"Sinking of the Jubilee Shaft, Sydney Mines."

Prof. F. H. Sexton—"Vocational Training for the Crippled Soldier."

A. J. Toner—"Mine Fires. Their Origin, Control and Extinction."

As the business of the meeting was confined to one afternoon session there was not time to read and discuss the whole of the papers. The papers will, however, appear in the society's transactions, and it was decided by the meeting that all the papers should be open for discussion at the next annual meeting, which, it is hoped if war conditions will permit, will resume the customary form of a two days' meeting with the annual dinner.

On the recommendation of the Executive the meeting appropriated the sum

of \$100 to the "Belgian Kiddies Fund" of which E. P. Mathewson of Toronto is the chief sponsor for Canada. The meeting was actuated in its selection of the "Belgian Kiddies Fund" by a desire to honor H. C. Hoover. As a leading member of the mining profession, Mr. Hoover's record during the war has been one which reflects lustre on the profession, and the fact that he is a citizen of our latest ally is fully appreciated.

A select committee composed of Messrs. T. J. Brown, G. D. MacDougall, Prof. F. H. Sexton, and F. W. Gray was named to look into and report on the possibility of finding some satisfactory basis of federation or affiliation with the Canadian Mining Institute.

The meeting moved that there be recorded in the society's transactions a resolution setting forth the unanimous appreciation of all the members of the society of the patriotism and self-sacrifice of the miners of Nova Scotia during the War. The resolution covered all branches of mining in the province, as it was felt that the rank and file of the profession, whether coal-miners or metalliferous miners, evinced the same eagerness to serve their country on the firing line. The meeting adjourned in the late afternoon and there was no evening session. The consensus of those who attended was that the meeting had been extremely successful.

The number of papers presented and offered did not by any means exhaust the capacity of the members and the time at the disposal of the meeting was all too short for full discussion. The society will have sufficient material in its transactions for 1917 to provide the widest scope for mature discussion at the next annual meeting, without the necessity of additional papers.

The meeting was thoroughly representative of the mining profession of Nova Scotia and was entirely made up of practical men busily engaged in the daily practice of their profession.

—*Canadian Mining Journal Report.*



CANADA'S MARCH EXPORT TRADE

CANADIAN exports of manufactured goods rose in the month of March to unprecedented figures, \$69,239,486, exceeding the total for that division of our export trade in the full twelve months of 1914 by \$87,562. The previous high mark for any month since war orders began to swell our export figures was \$54,261,266.

With munitions output at the present time probably the largest yet achieved, and goods to a value of approximately \$300,000,000 still to be shipped under old orders, March figures should be equalled or exceeded in the next few months. The one thing that may stand in the way of such a result would be the diversion of shipping to the carrying of food supplies rather than munitions, under more urgent needs for the former than the latter. That, however, is problematical.

The detailed March return offers an encouraging contrast to that of Febru-

ary, when the forward movement of goods from the Atlantic seaboard was temporarily checked by railroad congestion and the new German submarine menace. In February exports fell off to \$68,224,383 and were less than \$200,000 in excess of imports. In March they rose to \$122,415,313, and although imports expanded rather sharply there was a trade balance in Canada's favor of \$20,079,427.

Exports were approximately 34 millions higher than in March a year ago, but imports increased still more sharply, rising about 40 millions. The actual balance was, therefore, about six millions less than in March, 1916. This is disappointing in some respects, but the showing is still an amazingly good one, judged by before-the-war standards. The comparisons continue little short of startling. In the good business year of 1913, after a big crop, Canada exported in March goods to the value of \$34,874,000. Four years later the figures were approximately four times as large. There was a balance against Canada in March, 1913, amounting to upwards of 32 millions, which is this year replaced by a favorable balance of 20 millions.

Comparisons of exports and imports in March for six years, taking only domestic produce under the head of exports, and excluding foreign goods and gold from both export and import figures, are given in the following table:

March	Exports	Imports	Balance
1917	\$122,415,000	\$102,335,000	+\$20,079,000
1916	88,414,000	62,034,000	+ 26,380,000
1915	45,118,000	30,111,000	+ 15,007,000
1914	26,700,000	53,111,000	- 26,411,000
1913	34,874,000	67,603,000	- 32,729,000
1912	24,980,000	58,053,000	- 33,073,000

- In favor of Canada.
Against Canada.

The March exports in the usual classification shows gain over March, 1916, in every instance except the minor "miscellaneous" item. Comparisons follow:

	1917.	1916.
The mine	\$ 9,980,711	\$ 8,004,843
The fisheries	2,373,258	2,054,493
The forest	3,614,385	3,247,691
Animals, etc.	14,809,911	8,626,681
Agriculture	21,962,252	17,852,426
Manufactures	69,239,486	47,013,766
Miscellaneous	435,280	1,614,338
	\$122,415,313	\$88,414,238

The volume of the trade in March was considerably larger than in either January or February, although January yielded a net result more favorable to the country's external trade position. The continued rise in imports is disappointing in some respects, but it may be doubted whether it can be assigned to any larger part to extravagant buying. Large importations of raw materials have been found necessary to carry out war orders when production of such materials within Canada had reached the limit of capacity. Increased imports of that description go forward into still larger figures in the export account later on.

Exports and imports for the first three months of the year compare as follows:

	Exports	Imports	Balance
1917	\$ 99,106,259	\$ 72,323,074	+\$26,783,185
Jan.	68,224,383	68,030,469	+ 193,914
Feb.	122,415,313	102,335,886	+ 20,079,427
March	\$289,745,955	\$242,689,429	\$47,056,526

PROGRESS IN NEW EQUIPMENT

A Record of New and Improved Machinery and Accessories for the Machine, Pattern, Boiler and Blacksmith Shops, Planing Mill, Foundry and Power Plant

BORING AND RECESSING MACHINE FOR AIRCRAFT MANUFACTURE

IN view of the fact that the manufacture of aircraft on a big scale is now being undertaken in Canada, the accompanying description of a boring and recessing machine for the wood propellers, designed by Thomas Robinson & Sons, Rochdale, England, should prove of more than passing interest. We are indebted to our British contemporary, The Engineer, for the data and illustrations. The machine evolved is intended for boring and recessing the bosses or hubs of airscrews or propellers, and, in addition, for half lapping and mitreing the laminations of four bladed propellers, as well as for recessing and drilling the spars and struts. Needless to say, the most accurate machining is required in these operations to ensure perfect balance and true running of the propeller.

The ordinary type of boring machine, particularly where the spindle passes through its bearings, failed to satisfy the demands for the extreme exactitude and fine limits necessary in this class of work, though fairly satisfactory results were obtained as temporary measures by resort being had to devices for steadying the boring bits from below the work. These devices, however, impeded the operator, being difficult to set up and in the way when in position. Moreover, the old type machines were too restricted in their range of movement, ample provision in this respect being desirable not only for facilitating handling and ensuring the maximum output, but also for the purpose of preventing all avoidable disturbance of the propeller once the latter is set in position on the table of the machine.

The machine illustrated is claimed to leave a perfectly clean and true centre hole in the hub of the largest propeller, using a two wing twist bit as known to most machine woodworkers. The makers point out as a highly important feature of the machine, the method adopted for mounting the spindle. The whole head, complete with its bearings, rises and falls bodily, so that the maximum support is given to the spindle in all positions of the head. In the general type of wood borer, the spindle passing through its bearings must of necessity overhang, the overhang increasing with the depth of the hole to be bored, with, as a result, vibration and inferior work. The bit need only be steadied by its own shank in the spindle chuck, although a bit with a pin steady is sometimes preferred for finishing accurately to size. Other users prefer an adjustable recessing form of tool so that the diameter can be corrected for wear. By merely changing the boring bit or tool, a propeller hub can be completely bored, rounded on the edge of the hole, recessed when necessary, and the bolt holes drill-

ed, without disturbing the setting of the work, i.e., the propeller, on the machine table. The compound movements of the table itself give all the required differences in position for the work. The machine is also made to suit the other method of working wherein given operations are confined to particular machines.

When recessing panels in the spars of aircraft, a former or profiling plate can be used to give the correct shape of the panel required; and, for half lapping and mitreing, a large diameter recessing cutter of suitable shape is all that is necessary, the timber being traversed past the cutter to form the recess or half lap. In the matter of speed also, the new machine is claimed to offer a solution of the one-speed objection more often than not found in borers of the old type. The latter generally ran about 1,000 revolutions per minute, while the new machine is arranged with three speeds, 1,200, 2,000 and 3,000 revolutions per minute.

The spindle head complete with its ball bearings which are of the "Skefko" double-row type, rises and falls on the main pillar. It is provided with the three speeds stated above, and is driven by belt over a pair of guide pulleys from a three-step cone on the counter-shaft at the back of the machine. The spindle head has a vertical movement by hand lever of 6 in., and by screw of 6 in., the maximum combined movement being 10 in. The driving pulley on the spindle is built up from steel tubing for lightness. It is 3½ in. diameter by 12 in. long, and carries a belt 2½ in. wide. The distance from the centre of the spindle to the machine pillar is 18½ in., and the spindle is arranged to swing cutters up to 7 in. diameter in the topmost position. Larger cutters, however, can be used if the spindle is lowered slightly. The chuck is bored for 1¼ in. diameter shanks.

The size of the table is 39 in. by 19 in. It is slotted to carry a back fence and screw clamp and also eccentric lever clamps. It has a longitudinal traverse by screw of 15 in., a cross traverse by screw of 12 in., and a vertical adjustment by screw of 9 in. The maximum distance between the chuck and the table is 24 in. The table is also arranged to cant 30 degs. sideways, and to the front.

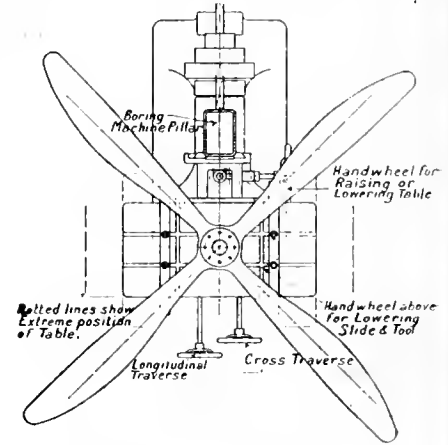

PLAN OF PROPELLER BORING AND RECESSING MACHINE.

All the motions of the spindle head and the table are provided with adjustable stops to pre-determine the movements required, and all the levers and handwheels are, as will be observed, brought to a convenient position for the operator. The fast and loose driving pulleys are 8 in. diameter by 4½ in. face, and run about 750 revolutions per minute.

Although the machine was primarily designed for aircraft work, it will be readily understood that it has very wide application for general mechanical wood-

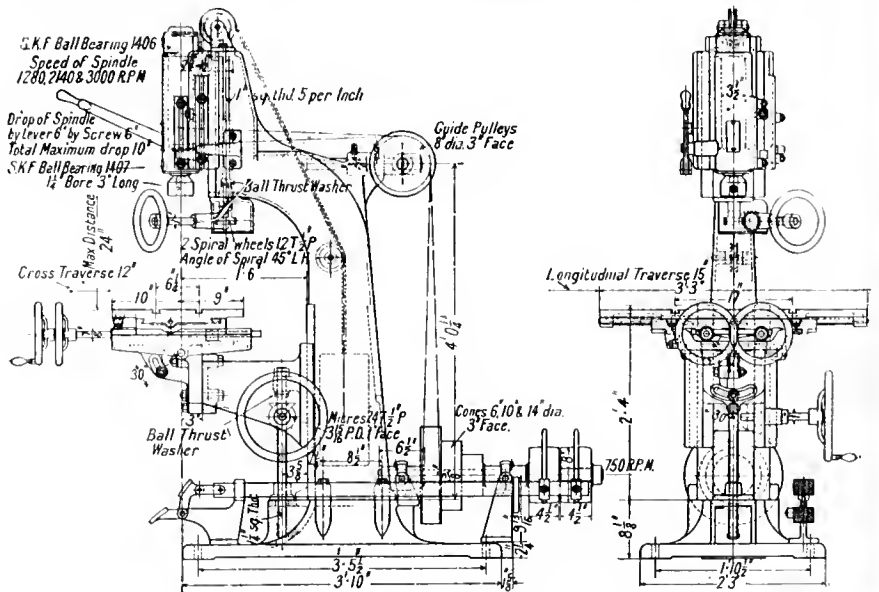

AIRCRAFT PROPELLER BORING AND RECESSING MACHINE.

working, especially where either large, multiple, or fine limit work is required. Its installation, therefore, need not be considered, the makers urge, on the temporary basis as being only useful "for the duration of the war," since it will be a live and economic factor in any scheme for changing over from war to peace work.



METAL MELTING IN A SIMPLE CRUDE OIL FURNACE*

By H. S. Primrose

NOT every locality which has been selected for the large-scale melting and production of non-ferrous metals and alloys has been favoured with the possession of a high-pressure or cheap gas supply to facilitate operations. Many firms have therefore been content to purchase various forms of fixed or tilting furnaces of the oil-fired type and found them satisfactory. The chief difficulty with the majority of these, however, has been to retain or obtain the services of sufficiently skilled workers to operate the larger sizes so as to maintain uniformly good results both in the composition and strength of the castings and billets produced. The writer has been privileged to assist in the evolution of a very simple and efficient type of fixed oil furnace introduced by the Crittall Mfg. Co. for Government work, chiefly in connection with the rapid production of various grades of brass. The design is exceedingly simple, and permits of the use of unskilled labour throughout in its operation. The working drawings are reproduced to scale, and show the plan and several elevations of a single furnace, which is the left-hand unit of a pair of similar furnaces.

Construction

The furnace proper is constructed of the simplest engineering materials. The outer shell or casing is made of mild steel plates bolted together to form a rectangular box, the height of which may be varied to take large or small-sized crucibles. The one illustrated is capable of holding 100 up to 200 lb. pots, their elevation in the furnace being governed by the thickness of stool employed to raise them from the floor brick. The lining is of ordinary firebrick set in ganister to leave a circular opening, the corners between the lining and casing being packed with sand as an insulating material. The top of the furnace consists of two cast-iron plates resting on the top ring of firebrick and leaving a circular opening over which the furnace cover is placed during melting. The platform for the workmen is conveniently made of chequer plates, carried round all four sides of the furnace on channel or angle bars. This top also serves as a runway on which to move about the two-wheeled lifter for the furnace cover, which consists of a circular flat firebrick with a conveniently small aperture

in the centre. The cover is bound round with a stout band of iron which serves to hold it together, and to enable it to be moved aside by the prongs of the lifting carriage.

It has been found that the best arrangement is to have the whole furnace above the floor-level, so that no pit or special foundation is necessary, and the construction and keeping clean of flues are completely done away with. In the event of a crucible cracking in the furnace whilst full of molten metal, there is no difficulty in removing the spilled metal through the frontal opening, which is usually, in working, kept closed by luting in a firebrick.

Air Supply

The space between each pair of furnaces can be utilised in conveying the necessary pipe-lines for the air and oil

duced in the foundry to not more than 25 lb. per square inch effective pressure at the burner valve. The burner must then be of the special high-pressure design, which is found to be exceedingly effective in producing the necessary pulverising action on the heaviest types of crude oil employment, and in this way high economy in melting may be secured. Such low figures as 1.5 gals. consumption for each hundred pounds of brass melted can be consistently maintained. The slightly increased cutting action of the high-pressure burner flame, both on the furnace lining, where carbonisation is likely to result, and on the crucibles themselves, makes this extreme saving of oil a questionable advantage in view of the short life of the crucibles and the more frequent patching required for the furnace lining.

Most satisfactory results have been

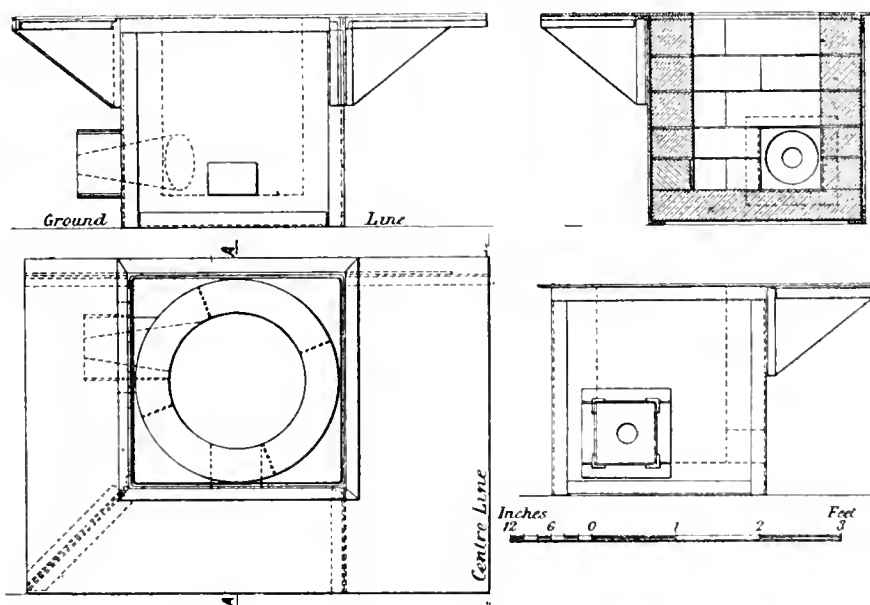

ELEVATIONS AND PLAN OF SIMPLE CRUDE OIL FURNACE.

supply close up to the opening of the burner brick. Valves are, of course, required to regulate the inlet of each, so that the correct pulverising of the oil into a suitable spray is effected to give the right flame to envelop completely the crucible and have a small flame protruding from the cover opening.

The shape of the special burner brick allows the oil spray to spread out in a conical fashion, and, igniting on entering the furnace with a tangential motion, it causes the flame to sweep round in the annular space between the furnace walls and the crucible before passing out at the central opening in the firebrick cover. By using a single burner brick of the required shape, and also by having the firebrick slab for the floor of the furnace in one piece, there is no chance of leakage or escape of unconsumed oil, and as it is thus all burned inside the furnace, great economy in the heating power results, and uniform time of melting may be relied upon.

The form of oil-burner depends upon what type of air-pressure plant is installed in the works. Where compressed air is already in use it must be re-

obtained with the use of low-pressure burners, which can be used in cases where no high-pressure air system is in vogue. Small high-speed electric fans capable of producing about 12 oz. air pressure (i.e., from 20 to 22 in. of water gauge) can be readily employed to work four furnaces simultaneously. The only precaution to be taken in such a case is that the furnaces should be started up from cold not more than two at a time, and those which are not immediately in use at any period can have the air supply cut off separately. The consumption in this method of working is slightly more than two gallons per 100 lb. of metal melted, but against that must be offset the advantage of being able to melt with perfect regularity against time, as not more than 35 minutes are required to melt completely and pour 100 lb. of brass. 200-lb charges require only 50 to 55 minutes.

Advantages

In addition to the advantage of being completely operated by unskilled labour, these furnaces have the obvious advantage of being easily removable, as they

*From a paper read before the Institute of Metals, March, 1917.

can be set down anywhere on a reasonably smooth floor. Besides being exceedingly easy to repair, they are constantly under the most complete control, simply by regulating the air and oil inlet valves. Their first cost is not great, and repairs are a very small item in their running. A large number have been in continuous operation night and day for over a year without any necessity for relining, and only slight attention to the walls in the way of patching with ganister has been needed. They are not nearly so destructive on crucibles as the various forms of gas flame employed in melting furnaces, and the ever-present trouble of clinkering, as with coke-firing, is completely done away with. The only resemblance to cleaning which must be attended to and that only on occasion when the correct air quantity has not been maintained during a run with very heavy or viscous fuel oil, is the deposition on the furnace wall opposite the burner of small accretions of solid carbon. It should never be allowed to interfere with the proper circulation of the heating flame, and the deposit must be barred off and removed when the crucible is withdrawn for pouring.

With 100-lb. pots there is no difficulty in withdrawing the crucible full of molten metal by hand, but when 200-lb. pots are used it is advisable to resort to a mechanical aid such as the quadrant lifting arm, with a chain to hook on to the basket lifting tongs. This very much lessens the chances of accident and minimises the effect of unsteady lifting out when manual labor alone is employed.

Melting Results

In a properly organized brass foundry all mixtures are controlled by analyses, and the charges accurately weighed out, after briquetting, if necessary. In this way it is quite feasible to do without any fresh copper. Complete returns are kept of the work and output of each shift and these may be abstracted for each grade of metal made. The following table represents one month's output of "G" metal only:—

Metals melted:	lb.
Zinc	65,920
Cartridge cases	349,813
Swarf	709,218
Scrap	357,549
Total	1,482,500
Flux used, 7,312 lbs.	
Aluminum deoxidiser, 820 lbs.	
Foundry Production: Number of melts	
14,825 of 100 lbs.	
Billets produced, 124,855 —	1,312,225
Scrap and spilled metal . .	26,539
Metallurgical shot recovered from	
.. foundry dross	73,920
Total	1,412,684
Melting loss — 1,482,500 —	1,412,684
— 69,816 lbs. — 4.7 per cent.*	

*The amount returned as loss is somewhat in excess of its actual value, as the weight of metallic shot recovered (33 tons) represents an average of only 60 per cent. of the total dross produced and treated by simple washing. Further treatment by concentrator revealed nearly 30 per cent. more metal to be got out.

Number of furnaces working, 18 to 22.
Total oil consumed, 32,599 gallons.
Oil consumed per 100 lbs. of metal melted, 2.2 gallons.

ROYAL COMMISSION REPORT ON RAILWAYS.

THE Royal Commission appointed last July by the Dominion Government to inquire into the general problem of transportation in Canada has submitted its report. The report was presented to Parliament on May 3. The Commission consisted of Sir Henry Drayton, Chairman of the Dominion Railway Commission, W. M. Acworth, a British expert on railway rates and economics, and A. H. Smith, president of the New York Central lines. The majority report was accompanied by a minority report by A. H. Smith, who differs from the other commissioners principally on the question of nationalization.

Majority Report.

The majority report prepared by Sir Henry Drayton and Mr. Acworth, involves the creation of practically two great systems in Canada, one publicly owned and the other a private enterprise, the Canadian Pacific, both under control as to rates, of the Dominion Railway Board, both operated by expert railway men, both serving their own economic territories, competing with each other, but each serving the people who contributed nearly all the financial assistance which built them.

The report declares that if the chief bane of Government operation of railways, namely, political interference, is eliminated, the proposed new great national systems, operated on a strictly commercial basis, can be put, within a comparatively short period of years, upon a satisfactory financial basis.

Minority Report.

The American railroad expert is opposed to Government ownership and operation, believing that the best results can be achieved by continuing private enterprise, with the reorganization and better co-ordination of the work of the Grand Trunk Pacific, Grand Trunk, National Transcontinental and Canadian Northern. He recommends, in brief, the taking over the Grand Trunk Pacific with its branch lines in the West by the Canadian Northern, leaving the latter company free to operate in the Western part of Canada, while the Grand Trunk should lease the Eastern lines of the Canadian Northern from North Bay east, and confine its operations to Eastern Canada. With regard to the Intercolonial and National Transcontinental, he believes that they should be left as at present as a continuous system from seaboard to the grain-distributing centres. The Commissioners agree that the Canadian Pacific is now giving good service, and should not be interfered with. The Commissioners also agree that present conditions are economically bad, that there is wasteful duplication of lines, lack of co-ordinated transportation economy, and heavy deficits to be met on

behalf of the railways by the people of Canada for years to come, unless some scheme of radical reorganization is promptly carried out.

FISHERMEN V.C. AND THE KING TOM WING, M.P., tells how he accompanied a fisherman from a mine-sweeping trawler, who was awarded the V.C., to Buckingham Palace to receive his decoration from the King.

"He rolled along with me in true seafaring style," says Mr. Wing, "until, as we approached the gates, I remarked, 'We must pull ourselves together, otherwise we shall not be admitted.' My gallant friend who had been chewing a plug of tobacco, took it out of his mouth and carelessly put it in his cap.

"It is usual for the King to shake hands with recipients, and when he did it on this occasion my man would not let go. He held on, and to make certain it was all right, he put his other hand on it. Then he looked at his Majesty as much as to say: 'Are you the King, or are you only "kidding" me?'

"When we got outside he said it was all like a dream, and he felt for his pipe to make quite sure he was awake."

CANADIAN TONNAGE REDUCED

A SLIGHT reduction in the tonnage of ships on the Canadian register during the first two months of the year is shown by statistics compiled in the Marine Department at Ottawa. At the end of February the total tonnage was 475,693 representing sailing vessels, and 794,314 representing steamships, as compared with 476,983 tons in sailing ships, and 799,183 tons steamers at the close of December last.

In January vessels having an aggregate tonnage of 11,743 were transferred from the British register to Canada, and 900 tons were accounted for by new construction. February the figures were, new construction 1,164 tons; transfers from British to Canadian register 1,464 tons; transfers from foreign to Canadian register 758 tons.

There were stricken off the Canadian register in January 14 sailing vessels, aggregating 1,271 tons, which were broken off, five small steamers similarly disposed of and vessels of 4,440 tons in all sold in the United States. In February 5,286 tons were lost through wrecks and 2,212 tons were accounted for by vessels condemned.

Didn't Recognize Danger.

The black sheep of the family had run away to sea. The first night he was on the lookout and suddenly spied three lights—red, green, and white—the port, starboard and masthead of an approaching vessel. Every seaman knows that when these three lights are to be seen at the same time it means danger, but the black sheep wasn't a seaman.

"Ahoy, there!" yelled the officer on deck. "What's that ahead of us?"

"Don't know," answered the black sheep, calmly. "I think it's a chemist's shop!"

The MacLean Publishing Company

LIMITED

(ESTABLISHED 1888)

JOHN BAYNE MACLEAN - - - - - President
 H. T. HUNTER - - - - - Vice-President
 H. V. TYRRELL - - - - - General Manager

PUBLISHERS OF

CANADIAN MACHINERY AND MANUFACTURING NEWS

A weekly newspaper devoted to the machinery and manufacturing interests.

PETER BAIN, M.E., Editor. B. G. NEWTON, Manager.

Associate Editors

A. G. WEBSTER J. M. WILSON J. H. RODGERS

Office of Publication, 143-153 University Avenue, Toronto, Ont.

Vol. XVII. MAY 10, 1917 No 19.

DEVELOPING OUR SHIPBUILDING ALONG RIGHT LINES

JUST what Canada's contribution will be towards curbing Germany's submarine menace is somewhat problematical. The situation as we see it is a complex one, although if judgment were to be based on the lavish expenditure of printers' ink setting forth the ease and rapidity with which seaworthy ocean carriers can be fabricated and commissioned, there is little to it. The steady depletion of the world's shipping by enemy submarines has reached a crucial stage and rehabilitation is of the greatest possible urgency. We have apparently lost sight of the fact, however, that extermination of the menace is rather more worthy of attention than the multiplication of targets for its special benefit. What availeth, even were Great Britain, the United States and Canada, able to float a ship per ship sunk, if "plunger" warfare be not speedily arrested and ultimately wholly eliminated. A "feed the brute" policy is essentially wrong and has not the faintest hope of success of any kind, unless it be the imaginary one of using up German raw materials—the constituent of torpedoes and a few ill or well-directed shell, or be the most temporary of stop gap expedients.

The effort to develop a Dominion-wide shipbuilding industry is a laudable one, even although there is little novelty about it beyond the meantime hysterical setting born of lack of knowledge of what is involved and originating in sources as far removed from worth-while achievement as the Poles are apart, and with about the same prospect as the latter of coming together. There is an evident disposition to infer that because "sermons are to be found in stones and books in running brooks," shipyards are to be found on trees, in departmental stores or other equally foolish locations, ready-made. The movement to create a "broad gauge" shipbuilding industry in Canada has been operative for quite a number of years, and the outbreak of hostilities has but served to steel the energies of the men behind the movement to still greater effort. It has never been recognized, however, as the Nation's Business,

and if one may express an opinion on the situation as we find it to-day, recognition is still lacking.

In April, 1913, fifteen months preceding the declaration of war, a Memorial was presented to the Canadian Government which in very full detail set forth the numerous disabilities under which our shipbuilders labored, and demonstrated beyond question the benefits which would accrue to our citizens as a whole if a real, earnest attempt were made to foster the industry officially. To-day we are inclined to think this Memorial is a haunting nightmare to the responsible Government at Ottawa. That action solicited and refused four years ago cannot now be longer delayed is generally admitted, while evidence of a veering round to it is already apparent in our Finance Minister's offer of \$10,000,000 to the Imperial Munitions Board with a view to stimulating at least wood shipbuilding.

We are not of those who deem the Imperial Munitions Board incapable of directing Canada's as well as Britain's shipbuilding programme, and from the manner in which shell production has been developed and expanded under its administration, few will be inclined to differ with us. Under any circumstances, even those prevailing on the high seas to-day, let us keep common-sense and reason from running riot to the extent that we can build up a sound, permanent, worth-while shipbuilding industry overnight, so to speak, for it can't be done. The men who have been bearing the burden and heat of the day in past years by keeping the industry alive, and who more than any others are the real judges of the whole situation, had this to say on the subject in their Memorial of four years ago:

"Apart from managers, superintendents, clerks, etc., the staff of foremen for the shipfitters, pipefitters, plumbers, coppersmiths, boilermakers, sheet iron workers, riveters, moulders, patternmakers, machinists, blacksmiths, carpenters, joiners, painters, mold loftsmen, riggers, pneumatic tool men, helpers, etc., is very large; and these men must be permanently employed, carefully selected, and gradually picked up. It takes about seven years to build up a good organization. The last named consideration makes it apparent that any scheme of aid, once embarked upon, should be guaranteed for a fixed period, and long enough to enable yards to get their organization established and then show results. An aid period of ten or fifteen years is indicated."

A parallel has been sought to be drawn between shell-making and shipbuilding, to the extent that our almost immediate success in tackling the former means a correspondingly prompt achievement in the latter. To those who so reason, a few minutes heart to heart talk with any of our shipyard managements on the labor phase of vessel construction as compared with that of shellmaking, would be worth a whole lot, so much so that it would possibly be discovered that they know quite as much about the in'ards of the one industry as about the other, and quite little of either.

We are not of those who despair of Canada taking a prominent place in the world's shipbuilding and shipowning, rather are we keenly optimistic about it, and while in the past little heed was paid the possible importance of either, or their opportunities, the world-wide dearth of ocean transport has now come equally close home to us as it has to other warring or neutral nations, and demands that notice be taken and action be initiated. The inherent possibilities of shipbuilding and marine engineering are realized as never before in our experience, combining as they do staple industries in themselves, of large proportions, and the medium through which a myriad other enterprises, large and small, agricultural, mineral and manufacturing, may find opportunity to expand and develop.

SELECTED MARKET QUOTATIONS

Being a record of prices current on raw and finished material entering into the manufacture of mechanical and general engineering products.

PIG IRON.	
Grey forge, Pittsburgh.....	\$39 95
Lake Superior, charcoal, Chicago.....	46 75
Standard low phos., Philadelphia.....	75 00
Bessemer, Pittsburgh.....	43 95
Basic, Valley furnace.....	40 00
Montreal Toronto	
Middlesboro, No. 3.....	
Cleveland, No. 3.....	
Clarence, No. 3.....	
Hamilton.....	
Victoria.....	

FINISHED IRON AND STEEL.	
Per lb. to Large Buyers Cents	
Iron bars, base, Toronto.....	4 75
Steel bars, base, Toronto.....	5 00
Steel bars, 2 in. to 4 in. base.....	6 00
Steel bars, 4 in. and larger base.....	7 00
Iron bars, base, Montreal.....	4 75
Steel bars, base, Montreal.....	5 00
Reinforcing bars, base.....	5 10
Bessemer rails, heavy, at mill.....	38 00
Steel bars, Pittsburgh.....	4 00
Tank plates, Pittsburgh.....	6 50
Beams and angles, Pittsburgh.....	4 00
Steel hoops, Pittsburgh.....	4 25
F.O.B. Toronto Warehouse.	
Steel bars, base.....	5 00
Small shapes.....	5 25
F.O.B. Chicago Warehouse	
Steel bars.....	4 25
Bars, 2 in. and up.....	4 40
Structural shapes.....	4 75
Plates.....	6 00

FREIGHT RATES.			
Pittsburgh to Following Points			
	Per 100 lbs.	C.L.	L.C.L.
Montreal.....	23.1	31.5	
St. John, N.B.....	35.1	45.5	
Halifax.....	35.1	45.5	
Toronto.....	18.9	22.1	
Quebec.....	18.9	22.1	
London.....	18.9	22.1	
Windsor.....	18.9	22.1	
Winnipeg.....	64.9	85.1	

METALS.		
Montreal Toronto		
Lake copper.....	\$38 00	\$37 00
Electro copper.....	38 00	37 00
Castings, copper.....	37 00	36 00
Tin.....	60 50	59 00
Spelter.....	13 50	12 00
Lead.....	13 00	12 50
Antimony.....	27 00	30 00
Aluminum.....	70 00	68 00

PLATES.		
Montreal Toronto		
Plates, 1/4 to 1/2.....	\$7 50	\$7 50
Heads.....	7 60	7 60
Tank plates, 3-16 in.....	7 60	7 60

WROUGHT PIPE.		
In effect May 3, 1917.		
Per 100 feet—	Black	Galv.
Buttweld.		
1/2 in.....	\$ 4 50	\$ 6 00
3/4 in.....	4 72	6 76
1 in.....	4 72	6 76
1 1/4 in.....	6 04	7 61
1 1/2 in.....	7 59	9 72
2 in.....	11 22	14 37
2 1/2 in.....	15 18	19 44
3 in.....	18 15	23 24
3 1/2 in.....	24 42	31 27
4 in.....	39 20	50 02
4 1/2 in.....	51 26	65 41
5 in.....	63 48	80 50
5 1/2 in.....	75 21	95 38
Lapweld.		
2 in.....	27 38	33 86
2 1/2 in.....	40 95	51 19

3 in.....	53 55	66 94
3 1/2 in.....	65 32	83 26
4 in.....	77 39	98 65
4 1/2 in.....	90 17	114 90
5 in.....	105 10	133 90
6 in.....	136 30	173 80
7 in.....	178 50	224 90
8 L. in.....	187 50	236 30
8 in.....	216 00	272 20
9 in.....	258 80	326 00
10 L. in.....	240 00	302 40
10 in.....	309 00	389 30

Prices—Ontario, Quebec and Maritime Provinces.

WROUGHT NIPPLES.	
4" and under, 50%.	
4 1/2" and larger, 45%.	
3" and under, running thread, 30%.	
Standard couplings, 4" and under, 40%.	
4 1/2" and larger, 20%.	

OLD MATERIAL.	
Dealers' Buying Prices.	
Montreal Toronto	
Copper, light.....	\$22 00 \$20 00
Copper, crucible.....	26 50 25 00
Copper, heavy.....	26 50 24 50
Copper wire.....	26 50 24 50
No. 1 machine com- position.....	22 50 20 00
New brass clippings.....	18 00 17 00
No. 1 brass turnings.....	16 00 16 00
Heavy melting steel.....	19 00 17 00
Steel turnings.....	8 00 8 00
Boiler plate.....	18 50 10 50
Axles, wrought iron.....	22 00 24 00
Rails.....	17 00 18 00
No. 1 machine cast iron.....	21 00 22 00
Malleable scrap.....	15 00 16 00
Pipe, wrought.....	12 50 9 00
Heavy lead.....	9 00 10 00
Tea lead.....	7 50 7 00
Scrap zinc.....	9 00 9 50
Aluminum.....	36 00 35 00

BOLTS, NUTS AND SCREWS.	
Per Cent.	
Coach and lag screws.....	30
Stove bolts.....	55
Plate washers.....	10
Machine bolts, 7-16 and over.....	10
Machine bolts, 3/8 and less.....	10
Blank bolts.....	20
Bolt ends.....	10
Machine screws, fl. and rd. hd., steel.....	27 1/2
Machine screws, o. and fl. hd., steel.....	10
Machine screws, fl. and rd. hd., brass.....	add 20
Machine screws, o. and fl. hd., brass.....	add 25
Nuts, square, up to 1 in., net list.	
Nuts, hex., up to 1 in., net list.	
Copper rivets and burrs, list plus.....	30
Burrs only list plus.....	50
Iron rivets and burrs.....	17 1/2
Boiler rivets, base 3/4-in. and larger.....	\$6.65
Structural rivets, as above.....	6.55
Wood screws, flat, bright.....	.72 1/2
Wood screws, O. & R., bright.....	.67 1/2
Wood screws, flat, brass.....	.37 1/2
Wood screws, O. & R., brass.....	.32 1/2
Wood screws, flat, bronze.....	.27 1/2
Wood screws, O. & R., bronze.....	.25

MILLED PRODUCTS.	
Per cent.	
Set screws.....	35
Sq. & Hex. Head Cap Screws.....	30
Rd. & Fl. Head Cap Screws.....	10
Flat 3/8 But. Hd. Cap Screws plus.....	10
Fl. & Semi-fl. nuts up to 1 in.....	25
Fl. and semi-fl. nuts, over 1 in., up to 1 1/2 in.....	30
Fl. and semi-fl. nuts, over 1 1/2 in., up to 2 in.....	10
Studs.....	20
Taper pins.....	40
Coupling bolts, plus.....	10
Planer head bolts, without fllet.....	10
Planer head bolts, with fllet.....	10 and 10
Planer head bolt nuts, same as finished nuts.....	
Planer bolt washers.....	net
Hollow set screws.....	list plus 20
Collar screws.....	list plus 30, 10
Thumb screws.....	20
Thumb nuts.....	65
Patch bolts.....	add 40, 10
Cold pressed nuts to 1 1/2 in.....	add \$4.50
Cold pressed nuts over 1 1/2 in.....	add \$7.00

BILLETS.	
Per gross ton	
Bessemer billets.....	\$ 80 00
Open-hearth billets.....	80 00
O.H. sheet bars.....	80 00
Forcing billets.....	105 00
Wire rods.....	85 00
F.o.b. Pittsburgh.	

NAILS AND SPIKES.	
Wire nails.....	5 00 4 95
Cut nails.....	5 00 5 00
Miscellaneous wire nails.....	60%
Pressed spikes, 5/8 diam., 100 lbs.....	5 50

MISCELLANEOUS.	
Solder, strictly.....	0 34
Solder, guaranteed.....	0 36
Babbitt metals.....	14 to 60
Soldering coppers, lb.....	0 53
Patty, 100-lb. drums.....	4 00
White lead, pure, cwt.....	16 03
Red dry lead, 100-lb. kegs, per cwt.....	13 87
Glue, French medal, lb.....	0 25
Tarred alaters' paper, roll.....	0 95
Gasoline, per gal., bulk.....	0 31 1/2
Benzine, per gal., bulk.....	0 30 1/2
Pure turpentine, single bbls., gal.....	0 69
Linseed oil, raw, single, bbls.....	1 40
Linseed oil, boiled, single bbls.....	1 43
Plaster of Paris, per bbl.....	2 50
Plumbers' oakum, per cwt.....	9 00
Packing, square braided.....	0 27
Packing, No. 1 Italian.....	0 32
Packing, No. 2 Italian.....	0 25
Lead wool, per lb.....	0 15
Pure Manila rope.....	0 31 1/2
Transmission rope, Manila.....	0 37 1/2
Drilling cables, Manila.....	0 32 1/2

POLISHED DRILL ROD. Discount off list, Montreal and Toronto..... 25%

CARBON DRILLS AND REAMERS.	
Per Cent.	
S.S. drills, wire sizes up to 52 40	
S.S. drills, wire sizes, No. 53 to 80.....	25
Standard drills to 1 1/2 in.....	10
Standard drills, over 1 1/2 in.....	45
3-fluted drills, plus.....	10
Jobbers' and letter sizes.....	40
Bit stock.....	40
Ratchet drills.....	15
S.S. drills for wood.....	40
Wood boring brace drills.....	25
Electricians' bits.....	30
Sockets.....	30

Sleeves.....	40
Taper pin reamers.....	20
Drills and counterdrills.....	list plus 30
Bridge reamers.....	45
Centre reamers.....	10
Chucking reamers.....	10
Hand reamers.....	15

COLD ROLLED SHAFTING. At mill..... list plus 40% At warehouse..... list plus 50% Discounts off new list. Warehouse price at Montreal and Toronto.

IRON PIPE FITTINGS.	
Canadian malleable, A, add 10%; B and C, 10%; cast iron, 35%; standard bushings, 50%; headera, 60; flanged unions, 40; malleable bushings, 50; nipples, 55; malleable lipped unions, 50.	

SHEETS.	
Montreal Toronto	
Sheets, Black, No. 28.....	\$7 75 \$7 85
Sheets, Black, No. 10.....	7 10 7 50
Canada plates, dull, 52 sheets.....	7 00 7 00
Canada plates, all bright.....	8 00 8 00
Apollo brand, 10 1/4 oz. galvanized.....	7 25 7 25
Queen's Head, 28 B. W.G.....	7 75 7 75
Fleur-de-Lis, 28 B.W. G.....	7 45 7 35
Gorbal's Best, No. 28.....	8 25 7 50
Colborne Crown, No. 28.....	8 00 6 75
Premier, No. 28 U.S.....	8 30 8 70
Premier, 10 3/4 oz.....	8 60 9 00

PROOF COIL CHAIN.	
B	
1/4 in.....	\$9 75
5-16 in.....	9 40
3/8 in.....	8 65
7-16 in.....	7 45
1/2 in.....	7 25
9-16 in.....	7 25
5/8 in.....	7 15
3/4 in.....	7 05
7/8 in.....	7 00
1 inch.....	6 90
Extra for B.B. Chain.....	1 20
Extra for B.B.E. Chain.....	1 80

ELECTRIC WELD COIL CHAIN B.B.	
1/8 in.....	\$15 50
3-16 in.....	11 70
1/4 in.....	8 40
5-16 in.....	7 40
3/8 in.....	6 35
7-16 in.....	6 35
1/2 in.....	6 35
5/8 in.....	6 35
3/4 in.....	6 35

FILES AND RASPS.	
Per Cent.	
Great Western, American.....	55
Kearney & Foot, Arcade.....	55
J. Barton Smith, Eagle.....	55
McClelland, Globe.....	55
Whitman & Barnes.....	55
Black Diamond.....	45
Delta Files.....	40, 5
Nicholson.....	45
Globe.....	55
Vulcan.....	55
Disston.....	55

COAL AND COKE.	
Solvay Foundry Coke.....	
Connellsville Foundry Coke.....	
Yough Steam Lump Coal.....	
Pittsburgh Steam Lump Coal.....	
Best Slack.....	
Net ton f.o.b. Toronto	

BOILER TUBES.

Size.	Seamless	Lap-welded
1 in.	\$24 00
1 1/4 in.	30 00
1 1/2 in.	32 00	25 00
1 3/4 in.	32 00	25 00
2 in.	35 00	26 00
2 1/2 in.	44 00	33 00
3 in.	47 00	38 00
3 1/2 in.	45 00
2 1/2 in.	59 00	48 00
4 in.	74 00	60 00

Prices per 100 feet, Montreal and Toronto.

OILS AND COMPOUNDS.

Castor oil, per lb.	27
Royalite, per gal., bulk	16
Palacine	19
Machine oil, per gal.	26 1/2
Black oil, per gal.	13
Cylinder oil, Capital	45 1/2
Cylinder oil, Acme	36 1/2
Standard cutting compound, per lb.	6 15
Lard oil, per gal.	1 45
Union thread cutting oil antiseptic	68
Acme cutting oil, antiseptic	37 1/2
Imperial quenching oil	39 1/2
Petroleum fuel oil	11 1/4

BELTING—NO. 1 OAK TANNED.

Extra heavy, single and double	30-50%
Standard	40%
Cut leather lacing, No.1	1 50
Leather in sides	1 35

TAPES.

Chesterman Metallic, 50 ft.	\$2 00
Lufkin Metallic, 603, 50 ft.	2 00
Admiral Steel Tape, 50 ft.	2 75
Admiral Steel Tape, 100 ft.	4 45
Major Jun. Steel Tape, 50 ft.	3 50
Rival Steel Tape, 50 ft.	2 75
Rival Steel Tape, 100 ft.	4 45
Reliable Jun. Steel Tape, 50 ft.	3 50

WASTE.

White	Cents per lb.
XXX Extra	20
Peerless	20
Grand	19
Superior	19
X L C R	18
Atlas	18
X Empire	18
Ideal	17
X press	16

COLORED.

Liou	14 1/2
Staudard	13
No. 1	13
Popular	11 3/4
Keen	10 1/2

WOOL PACKING.

Arrow	25
Axle	20
Anvil	15
Ancor	11

WASHED WIPERS.

Select White	12
Mixed colored	10
Dark colored	09

This list subject to trade discount for quantity.

RUBBER BELTING.

Standard	40%
Best grades	20%

ANODES.

Nickel	.50 to .54
Cobalt	1.75 to 2.00
Copper	.44 to .46
Tin	.39 to .56
Zinc	.23 to .25

Prices Per Lb.

COPPER SHEETS.

Montreal Toronto	
Bars, 1/2 to 2 in.	55 00 53 00
Plain sheets, 14 oz., 14x28 in., 14x60 in.	55 00 53 50
Copper sheet, tinued, 14x60, 14 oz.	60 00 54 25
Copper sheet, planished, 14x60 base.	64 00 60 00
Braziers', in sheets, 6x4 base	55 00 52 00

BRASS.

Brass rods, base 1/2 in to 1 in rd.	0 55
Brass sheets, 8 in. wide, 20 oz.	0 60
Brass tubing, seamless.	0 57
Copper tubing, seamless.	0 58

PLATING SUPPLIES.

Polishing wheels, felt.	2 10
Polishing wheels, bull-neck	1 35
Emery in kegs, American	06
Pumice, ground	04
Emery glue	15 to 20
Tripoli composition	04 to 06
Crocus composition	07 to 08
Emery composition	08 to 09
Rouge, silver	35 to 50
Rouge, powder	30 to 35

Prices Per Lb.

LEAD SHEETS.

Montreal Toronto	
Sheets, 3 lbs. sq. ft.	\$16 00 \$16 00

Sheets, 3 1/2 lbs. sq. ft.	16 00	16 00
Sheets, 4 to 6 lbs. sq. ft.	15 50	15 50
Cut sheets, 1/2c per lb. extra		
Cut sheets to size, 1c per lb. extra.		

PLATING CHEMICALS.

Acid, boracic	\$.15
Acid, hydrochloric	.05
Acid, hydrofluoric	.14 1/2
Acid, nitric	.10
Acid, sulphuric	.05
Ammonia, aqua	.08
Ammonium carbonate	.15
Ammonium chloride	.11
Ammonium hydrosulphuret	.40
Ammonium sulphate	.07
Arsenic, white	.12
Copper, carbonate, anhy.	.35
Copper, sulphate	.17
Cobalt sulphate	.70
Iron perchloride	.20
Lead acetate	.16
Nickel ammonium sulphate	.12
Nickel carbonate	.35
Nickel sulphate	.15
Potassium carbonate	.75
Potassium sulphide (substitute)	.20
Silver chloride (per oz.)	.65
Silver nitrate (per oz.)	.65
Sodium bisulphite	.10
Sodium carbonate crystals	.05
Sodium cyanide, 127-130%	.41
Sodium hydrate	.04
Sodium hyposulphite, per 100 lbs.	5.00
Sodium phosphate	.14
Tin chloride	.60
Zinc chloride	.60
Zinc sulphate	.09

Prices Per Lb. Unless Otherwise Stated.

The General Market Condition and Tendency

THAT prices of iron and steel will continue to advance seems now assured. Developments in the steel market in the United States point conclusively to higher prices and a more pronounced shortage of steel. These conditions will be reflected in Canada, affecting consumers in regard to both imported and domestic steel products. Manufacturers using merchant bars and small shapes, etc., are experiencing considerable difficulty in obtaining material for their factories and operations are being in many cases seriously restricted. In regard to imported materials, the situation seems likely to become more acute. The more important price changes to note this week include wrought pipe, steel spikes, iron rivets, fire-weld chain, billets and galvanized sheets, which have all advanced, while higher prices may be looked for on steel plate, boiler rivets, black sheets, bolts and nuts. The pig-iron situation is unchanged and domestic iron is still off the market, although there is some hope of improved conditions developing in the near future. Machinery cast iron and malleable scrap are higher and in good demand. Steel scrap is also in good demand at unchanged prices, but copper, brass and zinc scraps are dull and easy. The non-ferrous metal markets are firmer and the situation has generally improved. Tin and lead have advanced, but antimony is weaker and has declined. Copper quotations continue nominal and the market is quiet, although somewhat firmer than it has been during the past few weeks. Machine shop supplies continue in good demand at firm prices. The machine tool market is fairly active, business being of a more general character than formerly.

Navigation on the Great Lakes and Rivers has again become an active factor in the matter of transportation, and in many respects the railroads will be relieved from much of the heavy business, so pronounced during the past winter months.

Pig Iron

With the exception of a few advances on certain grades of American pig iron, the market is unchanged. The volume of business being placed for the coming year is gradually increasing and orders are now on the books for delivery in the second quarter of 1918. Advances this week are confined to the Pittsburgh district, the increase being nominally \$1 per ton. The advance on composite pig iron during the week has been 40 cents per ton. Canadian pig is practically off the market, but for what little is available dealers here are quoting the nominal price of \$50 per ton.

Steel

The attention of the steel industry is still centered in what the American government will do in connection with the purchase of steel and other requirements. With the close co-operation of the several Allied governments with that of the United States, in the formation of a policy in carrying on the war, it is anticipated that no radical changes will be made that might disturb the condition of present industrial activities. This to some extent will allay the anxiety that has been so prevalent during the past weeks, and producers are looking forward to the placing of government orders at prices much closer to those at present quoted, than those previously expected. An indication of future possi-

Montreal, Que., May 7, 1917.—The week has been comparatively quiet in industrial circles, no features having developed to change the general situation. Further announcements regarding the war policy of the United States are awaited with considerable interest, as it

is expected that some changes will result when the final arrangements are made. It is understood that the co-operation between the United States and the Allied nations will be of the closest description, and industrial operations will naturally be governed accordingly.

ilities may be had from the report that additional requirements for copper will be filled at much higher figures than those paid for the first lot ordered. While the United States naval requirements call for the purchase of steel plates at \$2.90 and bars and shapes at \$2.50, it is not expected that corresponding prices will be paid for other classes of steel, owing to the higher cost of production prevailing at the present time. With the entrance of the United States into the war, the situation has become much more complicated; some American producers are of the opinion that the Allies should be supplied at prices fixed by the U.S. Government for their own requirements, while others contend that current conditions should be maintained. The general market has been somewhat quieter this week and price advances have been few. Better conditions prevail in the delivery of billets and sheet bars to those consumers who get their supplies on regular contract; a quieter situation has developed in structural steel, consumers who can afford to wait are holding up construction, but in many cases the high prices that prevail are apparently little drawback to the buying of material. Recent developments promise the plate situation very little prospect of any relief for a long time to come.

Rail mills are fairly active, the demand both for home and export having shown a good increase during the week. Wire mills are having considerable difficulty in supplying the demands of the trade and an effect is being made to cut down orders so that a fair distribution can be made to the various consumers. While the prevailing price has not been changed, it is reported that sales are being made at higher figures than the market quotes. An advance that is soon expected to become general, has been made on wrought iron pipe, this advance being approximately \$12 per ton. The demand for this product has been so heavy that many mills are filled up for the remainder of the year and in some cases 1918 delivery has been accepted. The local situation is practically unchanged; dealers here report the demand has more of a normal tone, with the trade evidently awaiting the developments in the States before making additional demands upon the market. Delivery of material is much better but the difficulty appears to be in getting shipment from the mills.

Metals

The report that higher prices will be paid for additional copper requirements for the American government has had a cheering effect upon the general situation, but until a definite announcement has been made the trade will be kept more or less in an unsettled condition. Copper is somewhat stronger on the New York market. Tin is very strong and higher. Spelter is in better demand and stronger. Lead is higher and more active. Antimony is more plentiful and easier. Aluminum is firm and steady.

Copper.—It is reported that further purchases made by the American government for their future requirements, will be made on a basis of around 25 or 26 cents per pound; this possibility has had the effect of adding strength to the market. Negotiations now under way may result in the U.S. Government arranging for the purchase of all the copper required by the allied nations. This condition would have the tendency to eliminate competition and establish a fair price for supplies needed for war purposes. The consumption of copper at the present time is as heavy as ever in the past and even with the greater production during the past year, the supply is still below the demand. In addition to this, very little is known as to the actual losses through the activity of submarines. While general conditions show little change, the New York situation has a better tone, and higher quotations prevail; lake is $\frac{1}{2}$ c higher at $31\frac{1}{2}$ c; electrolytic has advanced one cent and is quoted at 32c, while castings at $29\frac{1}{2}$ c shows an advance of $2\frac{1}{4}$ c per lb. The local situation is unchanged with dealers quoting last week's prices of 38c for lake and electrolytic, and 37c for castings.

Tin.—Owing to consumers being well supplied for immediate needs and a lack of demand for future positions, the week's market has been very quiet. The apparent shortage of the visible supply has retained the market in an exceptionally firm position, and but for the poor demand the situation at present would be much stronger. Advances on the London market have also had a good effect here and a firmer tone is evident. New York quotation remains firm at $58\frac{3}{4}$ c per lb. On a good demand local dealers are asking $60\frac{1}{2}$ c, this being an advance of $2\frac{1}{2}$ c per lb.

Spelter.—Following the report that Government buying would probably be made at a much better price than previously anticipated, the New York situation has become stronger, and sales during the week have been greatly improved, together with heavy inquiry for future metal. However, the market is still undecided as to the actual intentions of the government and the situation is characterized by the uncertainty that has prevailed during the past few weeks. London is firm while New York quotations show an advance of $\frac{1}{2}$ c per lb., the current price being $9\frac{1}{2}$ c per lb. Local spelter is $\frac{1}{2}$ c stronger, the current quotation being $13\frac{1}{2}$ c per lb.

Lead.—Producers are still reluctant to make sales at prevailing prices until a declaration is made by the Government as to the price they expect to pay for their requirements. Dealers who have been striving to secure metal are now awaiting developments. Owing to the heavy demands for this metal the market retains a very firm position, with the undertone still stronger. The trust price during the week has advanced $\frac{1}{2}$ c the quotation being now $9\frac{1}{2}$ c; independents are asking $10\frac{1}{4}$ c, this being $\frac{1}{4}$ c higher than last week. The situation

here has taken on strength and dealers are asking 13c per lb., an advance on the week of $\frac{1}{2}$ c.

Antimony.—Recent heavy shipments of metal have increased the supply and the market has become easier. The situation is still influenced by the uncertainty of pending developments. Light demand and good supply has created a weakness on the New York market, a decline of $6\frac{1}{2}$ c placing the quotation at 27c per lb. Local antimony is still quoted at 27c per lb.

Machine Tools and Supplies

The machine tool situation is again being affected by prevailing conditions, more especially in the United States, where the industry is practically at the disposal of the government. While the machine tool plants are not under the direct supervision of the authorities, the placing of machinery is more or less in their hands, as certain equipment that has been under construction for neutral countries, has been diverted to war needs in the States, at the direction of the government. Production of government equipment is being executed with all possible speed. Both in Canada and the United States, the demand for wood working machinery has shown remarkable increase, owing to the great activity that has taken place in the shipbuilding industry. A fair business is still being done in single machines for munition makers, but the heavy activity in this respect has undoubtedly been passed, at least for the present. The probability that additional orders will shortly be placed for the lighter weight shells, may cause a resumption of machine tool activity in the early summer months. With the increased pressure recently placed upon the machine manufacturers in the States, together with the constant advance in the price of all raw materials, the higher cost of equipment will likely be an early future feature.

Scrap

The situation in the old metal market is still firm, but with an unsettled undertone, due to the uncertainty that characterises the conditions in general. Dealers report a fair business but are anxiously awaiting further developments, as they are reluctant to stock up under existing conditions. Steel and iron scraps are holding firm while old metals are somewhat firmer. New York is quoting an advance of $\frac{1}{2}$ cent on brass scraps and one cent on old zinc scrap, with slight increases on other metals. Prices here are unchanged.

Toronto, Ont., May 8.—Events in the United States are gradually assuming a definiteness of character, which is tending towards more settled conditions in Canada. Developments in the international situation indicate a continuation of the prosperity now prevailing in this country for some considerable time. Munitions work is showing signs of declining, although orders for shells will continue to be placed during the year.

Developments in the shipbuilding industry are being followed with interest, and this work will help to make up for the decline in the munitions industry.

Steel

Steel prices are still advancing, and there is no indication of any recession in the market. The demand for steel of all descriptions continues heavy, and is taxing the capacity of the mills to supply the tonnage required. The requirements, however, are such that the mills cannot take care of all the business offering, and consequently are behind on deliveries. The result is that there is a shortage of steel for many purposes other than munitions. The present high cost of steel, particularly structural material, is restricting building operation, while the high cost and scarcity of merchant bars and small shapes, etc., is handicapping manufacturers who use these materials. The scarcity of iron and steel is likely to become more acute as the demand is increasing, and consumers will be worse off than ever. Conditions in the steel trade in the United States are affecting the situation in Canada to a like degree. The American Government requirements of steel will undoubtedly be heavy, which in view of the sold-up condition of the mills will tend to force prices up. Steel prices in Canada will advance in sympathy, which means higher prices for the consumer on both imported and domestic material.

The more important price changes to note this week are wrought pipe, pressed steel spikes, proof coil chain, iron rivets and billets. Wrought pipe has advanced \$14 per ton, and includes both black and galvanized material. Pressed spikes have advanced 60c per 100 pounds, due to the high cost of raw material. For the same reason, chain has advanced approximately 5 per cent. The new discount on iron rivets, 7/16 in. and smaller is 17½ per cent. No change is noted in the situation in iron and steel tubes, and prevailing prices are largely nominal. The new demand for steel plates is heavy, and prices are very firm. In view of the heavy demand for plates, both present and future, higher prices are looked for.

Galvanized sheets have advanced 50c per 100 lbs., and are now quoted as follows:—Premier No. 28, U. S., \$8.70; and 10¾ ozs., \$9 per 100 lbs. Black sheets, No. 28 gauge, are a shade higher at \$7.85 per 100 lbs. The heavy demand for sheets in the States, combined with the high cost and scarcity of raw materials, is forcing prices up and further advances may be expected.

All indications in the market in the United States point to higher prices and more pronounced shortage of steel. Government buying is decidedly heavier, and will likely place large orders for steel within a short time. It is becoming more evident that the American Government and the Allies will combine in placing orders for steel, which may result in the present fixed prices being revised upwards so as not to disturb the situation. Steel bars have advanced to 4c, and tank plates 6.50c Pittsburgh. Bessemer bil-

lets, O.H. billets, and O.H. sheet bars are now \$80, and forging billets \$105 f.o.b. Pittsburgh. Ferro-manganese prices now range from \$400 to \$500 per ton.

Pig Iron

The pig iron situation locally is unchanged, and no prices are obtainable. In Buffalo, prices range around \$45 furnace for all grades. The furnaces are not anxious to do business, as very little iron is available that has not been contracted for. Prices have advanced on several grades of pig iron, including the following:—Grey forge, Pittsburgh, \$39.95; Lake Superior charcoal, \$46.75; and Bessemer, Pittsburgh, \$43.95.

Scrap

Prices of steel and iron scrap continue firm, with an upward tendency, but copper and brass are easy. Machinery cast iron has advanced to \$22, and malleable scrap to \$16 per ton. Heavy melting and other steel scraps are firm, but unchanged. Light copper is down 1c and scrap zinc is ½c lower.

Machine Tools

The general situation in the machine tool market is unchanged. Business continues fairly active on miscellaneous lines of a general character. Except on lathes, deliveries are not likely to im-

CANADIAN GOVERNMENT PURCHASING COMMISSION

The following gentlemen constitute the Commission appointed to make all purchases under the Dominion \$100,000,000 war appropriation:—George F. Galt, Winnipeg; Hormidas Laporte, Montreal; A. E. Kemp, Toronto. Thomas Hilliard is secretary, and the Commission headquarters are at Ottawa.

prove on imported tools, as the market in the States is becoming more active, due to increased demand for munitions equipment. Prices on machine tools are very firm, and will probably advance owing to the steady increase in cost of raw material.

Supplies

Business continues good and prices are very firm, showing, however, less tendency to advance. There have, however, been a few changes during the week. Locomotive screw jacks now carry a discount of 20 per cent, as against 35 per cent. formerly. Hand and platform trucks are now 10 per cent. off list. Asbestos wick packings are \$1.30 per lb., and asbestos millboard 25c per lb. Pure Manila rope has advanced 2c, and is now 33½c base, 5/8 in. and larger.

Metals

Although the situation has improved, the uncertainty as to the American Government requirements continues to be dominating factor in the metal markets. The fear that the Government purchases at low prices will depress the market is disappearing and giving way to a more optimistic feeling. Prices this week are

firmer. Tin and lead have advanced, but antimony is lower. Copper is showing more strength, but is unchanged, and prices continue nominal. Solders have advanced. Business locally continues brisk and the outlook is favorable.

Copper.—Prices are unchanged and nominal and the market is firmer. It is understood that the purchases of copper for the Allies are likely to be made through the American Government, which will tend to eliminate competition, and should result in fair market prices being established. The present Government price is 25c. There is no spot copper, and very little re-sale metal to be had. So little July copper is available that there is some difficulty in arriving at a definite price. Lake and electrolytic copper is quoted at 37c and castings at 36c per pound.

Tin.—There is a scarcity of spot tin and holders are not anxious to sell in view of the short supply and uncertainty of replenishment. The increase in insurance rates is also tending to stiffen prices of tin, while there is some uncertainty as to the amount of metal which will be allowed to come forward by the British Government. Tin has advanced 1c locally, and is now quoted at 59c per pound.

Spelter.—The demand continues light, and the market is dull, with prices unchanged. Buying by the American Government, which is expected shortly, is expected to strengthen the market. Local quotation, 12c per pound.

Lead.—The position of this metal continues strong, and it would only take a fairly insistent demand to send prices up. Lead has advanced ¼c, and is now quoted at 12½c per pound.

Antimony.—The market is weak and prices have declined. There is but little demand for spot antimony, but some interest is being shown in futures, principally May and June shipments from the East. Antimony has declined 6c locally, and is now quoted at 30c per pound.

Aluminum.—The market has grown a trifle easier, but quotations in the meantime are unchanged at 68c per pound.

Solders.—The high cost of tin and lead has resulted in an advance of 1c on solders. Guaranteed is now quoted at 36c and strictly at 34c per pound.



TRADE ENQUIRIES.

THE Department of Trade and Commerce, Ottawa, has received the following enquiries:

656. Sheet iron.—A manufacturers' agent in Newfoundland requires 10 bundles galvanized sheet iron 2 feet 6 inches by 6 feet, 18-gauge, 20 bundles black sheets 2 feet by 6 feet by 24-gauge, 15 bundles black sheets 2 feet by 6 feet by 26-gauge.

657. Bar iron.—A Newfoundland firm asks for quotations on 20 tons bar iron, 1 inch by ¾ inch; 200 tons, 1 inch by ¾ inch; 60 tons, 3 inches by 1 inch; 120 tons, 4 inches by 1 inch; 20 tons, 1 inches by 1½ inch; 10 tons, 6 inches by 1 inch; 20 tons, 2½ inches by ¾ inch; 40 tons, 2½ inches by ½ inch; 2 tons, ½ inch square iron; 4 tons, 1¼ inch round iron

Enlarged Canadian Trade Intelligence Service

Under the arrangement made by the Minister of Trade and Commerce with Sir Edward Grey in July, 1912, the Department of Trade and Commerce, Ottawa, is able to present the following list of the more important British Consulates whose officers have been instructed by the Foreign Office to answer inquiries from and give information to Canadians who wish to consult them in reference to trade matters.

BRAZIL—Bahia, British Consul. Rio de Janeiro, British Consul General.	NETHERLANDS—Amsterdam, British Consul.
CHILE—Valparaiso, British Consul General.	PANAMA—Colon, British Consul. Panama, British Vice-Consul.
COLOMBIA—Bogota, British Consul General.	PERU—Lima, British Vice-Consul.
ECUADOR—Quito, British Consul General. Guayaquil, British Consul.	PORTUGAL—Lisbon, British Consul.
EGYPT—Alexandria, British Consul General.	RUSSIA—Moscow, British Consul General. Petrograd, British Consul. Vladivostok, British Consul. Odessa, British Consul General.
FRANCE—Havre, British Consul General. Marseilles, British Consul General.	SPAIN—Barcelona, British Consul General. Madrid, British Consul.
INDIA—Calcutta, Director General of Commercial Intelligence.	SWEDEN—Stockholm, British Consul.
ITALY—Genoa, British Consul General. Milan, British Consul.	SWITZERLAND—Geneva, British Consul.
MEXICO—Mexico, British Consul General.	URUGUAY—Monte Video, British Vice-Consul.
	VENEZUELA—Caracas, British Vice-Consul.

Canadian Commercial Intelligence Service

The Department of Trade and Commerce invites correspondence from Canadian exporters or importers upon all trade matters. Canadian Trade Commissioners and Commercial Agents should be kept supplied with catalogues, price lists, discount rates, etc., and the names and addresses of trade representatives by Canadian exporters. Catalogues should state whether prices are at factory point, f.o.b. at port of shipment, or, which is preferable, c.i.f. at foreign port.

CANADIAN TRADE COMMISSIONERS.

ARGENTINE REPUBLIC—E. S. Webb, Acting Canadian Trade Commissioner, Reconquista, No. 46, Buenos Aires. Cable address, Canadian.
AUSTRALIA—D. H. Ross, Stock Exchange Building, Melbourne. Cable address, Canadian.
BRITISH WEST INDIES—E. H. S. Flood, Bridgetown, Barbadoes, agent also for the Bermudas and British Guiana. Cable address, Canadian.
CHINA—J. W. Ross, 13 Nanking Road, Shanghai. Cable address, Cancom.
CUBA—A. T. Quilez, Acting Canadian Trade Commissioner, Lonja del Comercio, Apartado 1290, Havana. Cable address, Cantracom.
FRANCE—Phillipe Roy, Commissioner General, 17 and 19 Boulevard des Capucines, Paris. Cable address, Stadacona.
JAPAN—E. F. Crowe, Acting Canadian Trade Commissioner, P. O. Box 109, Yokohama. Cable address, Canadian.
HOLLAND—P. H. Geleerd, Acting Canadian Trade Commissioner, Zuidblaak, 26, Rotterdam. Cable address, Watermill.
RUSSIA—C. F. Just, Canadian Government Commercial Agent, Alexandrinskaja, Plosh 9, Petrograd. L. D. Wilgress, Canadian Government Commercial Agent, Bukhholza Ulitza No. 4, Omsk, Siberia.
NEWFOUNDLAND—W. B. Nicholson, Bank of Montreal Building, Water Street, St. John's. Cable address, Canadian.
NEW ZEALAND—W. A. Beddoe, Union Buildings, Customs Street, Auckland. Cable address, Canadian.
SOUTH AFRICA—W. J. Egan, Norwich Union Buildings, Cape Town. Cable address, Cantracom.
UNITED KINGDOM—Harrison Watson, Sub-division E.C., 2, 73 Basinghall Street, London, E.C., England. Cable address, Sleighing, London. N. D. Johnston, Sun Building, Clare Street, Bristol. Cable address, Canadian. J. E. Ray, Central House, Birmingham. Cable address, Canadian. J. Forsyth Smith, 31 North John Street, Liverpool. Cable address, Cantracom. F. A. C. Biekerdike, 4 St. Ann's Square, Manchester. Cable address, Cantracom. J. Forsyth Smith, Acting Canadian Trade Commissioner, 87 Union Street, Glasgow, Scotland. Cable address, Cantracom.

CANADIAN COMMERCIAL AGENTS

AUSTRALIA—B. Millin, Royal Exchange Building, Sydney, N.S.W.
BRITISH WEST INDIES—Edgar Tripp, Port of Spain, Trinidad. Cable address, Canadian. R. H. Curry, Nassau, Bahamas.
NORWAY AND DENMARK—C. E. Sontum Grubbegd No. 4, Christiania, Norway. Cable address, Sontumis.
SPAIN—J. F. Roberts, Care British Consulate General, Barcelona.

CANADIAN HIGH COMMISSIONER'S OFFICE

UNITED KINGDOM—W. L. Griffith, Secretary, 17 Victoria Street, London, S.W., England. Cable address, Dominion, London.

(good quality); 4 tons, 1 inch round mild steel. Shippers to effect ordinary marine and war risk insurance.

667. Steel.—A Port Elizabeth firm requests particulars from Canadian manufacturers prepared to export octagon, spring steel and iron.

INCORPORATIONS

J. P. Quinlan Mfg. Co., has been incorporated at Toronto with a capital of \$40,000 to carry on a general sawmill and planing mill business at North Bay, Ont. The provisional directors are Joseph P. Quinlan, Maurice McQuinty and J. Landreau.

Steel Lockers Ltd., has been incorporated at Ottawa with a capital of \$40,000 to manufacture steel and metal lockers and furniture at London, Ont. The incorporators are William P. Brown, Herbert J. Sutherland and Charles E. Jarman all of London, Ont.

Turnbull Electro Metals Ltd., has been incorporated at Ottawa with a capital of \$50,000 to carry on business as iron and brass founders, engineers, boiler-makers, machinists etc., at St. Catharines, Ont. The incorporators are Robert Turnbull of Welland, Ont., James Brockett Tudhope and William H. Tudhope of Orillia, Ont.

The Hydraulic Machinery Co., has been incorporated at Ottawa with a capital of \$200,000 to manufacture and repair all kinds of hydraulic presses and pumps, and screw presses etc. Office at Montreal and the incorporators are Gerald A. Coughlin, Francis G. Bush and George R. Drennan all of Montreal.

The Nominique Pulp & Lumber Co., has been incorporated at Ottawa with a capital of \$300,000 to acquire and operate lumber and planing mills. Head office is at Montreal and the incorporators are Eugene Patenaude, Herbert G. Boyle and Louis Sessenwein all of Montreal.

Valleyfield Tool Mfg. Co., has been incorporated at Ottawa with a capital of \$100,000 to manufacture all kinds of machinery, tools, implements, foundry supplies etc., at Valleyfield, Que. The incorporators are James M. Garant, Charles G. Ogden and John L. Reay all of Montreal.

Colonial Supplies Ltd., has been incorporated at Ottawa with a capital of \$50,000 to manufacture lubricating and medicinal oils, soaps and greases etc. Head office is at Montreal and the incorporators are Spencer L. D. Harris, Charles Champoux and Charles H. Skelton all of Montreal.

Canadian Utilities, Steel & Engineering, Ltd., has been incorporated at Ottawa with a capital of \$49,000 to manufacture and deal in all kinds of gauges, tools engines and machinery with office at Montreal. The incorporators are John McNaughton, William B. Scott and James G. Cartwright all of Montreal.

INDUSTRIAL ^A_N^D CONSTRUCTION NEWS

Establishment or Enlargement of Factories, Mills, Power Plants, Etc.; Construction of Railways, Bridges, Etc.; Municipal Undertakings; Mining News

ENGINEERING

Montreal, Que.—Farand & Delorine will build an addition to their structural steel plant.

Chatham, Ont.—The Dowsley Spring & Axle Co., will extend their plant at a cost of about \$5,000.

Hamilton, Ont.—The Canadian Shovel Co., will build an extension to their plant. McPhie & Kelly of Hamilton, are the architects.

Montreal, Que.—The Dominion Bridge Co., Lachine, have equipped a part of their plant for building marine engines.

St. Mary's Ont.—The St. Thomas Quarry Co., who recently had a fire at their plant will rebuild the damaged section.

Tillsonburg, Ont.—The Tillsonburg Foundry & Machine Co. propose to erect a machine shop and install new equipment. The cost is estimated at \$10,000.

Esquimalt, B.C.—A workshop will be built here by the Department of Naval Service, Ottawa, from which full particulars of the proposed plant may be obtained.

Walkerville, Ont.—Construction work on the Chalmers Motor Co. plant, which was destroyed by fire recently, is well under way, and rebuilding will be proceeded with as fast as possible.

St. John, N.B.—Tenders will be called shortly for the erection of a power house and laundry at the General Hospital. The estimated cost is \$46,000. Full particulars may be obtained from F. Neil Brodie, architect, St. John, N.B.

Collingwood, Ont.—William Kennedy & Sons, steel plant, is now in full operation, an important contract for their product having recently been secured. A contract has been signed by the company with the Hydro-Electric Commission for an additional 1000 h.p. for the new electric furnaces.

Stratford, Ont.—A substantial addition to the present plant of the McLeod Milling Co. has been decided upon, and building operations are expected to commence at an early date. The existing steam plant will be taken out and electric motors installed throughout the mill. A new office building will also be erected.

Port Arthur, Ont.—J. J. Carrick, M.P., and his associates will shortly commence the erection of a pulp and paper mill, the initial unit of which will turn out 360 tons of pulp a day. A site covering 57 acres has been purchased just outside the city limits beyond Bare Point. Pulpwood will be obtained from the Black Sturgeon and Pic river limits. The initial unit will use about 18,000 h.p. which will be obtained from the Hydro-Electric

Commission who will develop the power from the Nipigon river.

Windsor, Ont.—The Windsor Tool & Machine Co. are building a one storey, 84 ft. x 52 ft. addition to their plant which will comprise a machine shop and office accommodation. The roof will have saw-tooth skylights over the centre of shop but will be constructed to carry machinery when another storey is added later. The windows will have steel sash and a fire protection system will be installed. A steam heating system and electric arc lamps will also be installed. The cost as estimated at \$10,000. J. C. Pennington of Windsor, is the architect.

MUNICIPAL

Guelph, Ont.—The City Council contemplate the purchase of a motor truck for the fire department.

Tillsonburg, Ont.—A by-law will be voted on by the ratepayers on May 14 to provide for exemption from taxation of the Canadian Cereal & Flour Mills Co.

Stratford, Ont.—The Public Utilities Commission has decided to purchase a number of fire hydrants for better fire protection.

Hamilton, Ont.—The Board of Control has decided to buy a motor flusher from the Menard Motor Flusher Co., of Windsor, Ont. The price will be \$5,550.

Sherbrooke, Que.—A by-law will be voted on shortly authorizing the borrowing of \$80,000 required for constructing a transmission line to the power development at Weedon.

Brantford, Ont.—Tenders will be called shortly for two pumps of 300 imperial gallons per minute each and 25 h.p. motors. Engineers, Chipman and Power, Toronto.

Oakville, Ont.—The Town Council has passed a by-law providing for an expenditure of \$20,000 for extensions and improvements to the water and light systems.

Tillsonburg, Ont.—The ratepayers will vote on a by-law on May 14 to grant \$10,000 by way of loan to the Tillsonburg Foundry & Machine Co., Limited.

Davidson, Sask.—A by-law will be submitted to the ratepayers on May 21 to raise \$8,000 for the construction of a new school and \$4,500 for power house improvements.

Toronto, Ont.—By a unanimous vote the Board of Control has decided to abandon any further work on the extension of Terauley street. This decision is in accord with a recommendation from the civic officials.

Hamilton, Ont.—The Board of Control has decided to apply to the Provincial

Board of Health for an order to have emergency steam pumps installed at the beach water works plant. The pumps will cost \$107,000.

Mitchell, Ont.—A by-law will be voted on by the ratepayers on May 21 to raise \$10,000 for the purpose of macadamizing certain streets and \$400 for the purchase of a site for a knitting factory for A. Burritt & Co.

Hamilton, Ont.—The Board of Control has decided to install a refrigerating plant, the cost not to exceed \$6240, in the new mountain hospital. This was the amount of a tender made by the Canada Ice Machine Co. of Toronto.

Toronto, Ont.—Approval has been given by the Board of Control to the plans of Parks Commissioner Chambers for proceeding with the city's share of the Humber boulevard work. The cost of this work will be \$15,000.

Rosthern, Sask.—A by-law will be prepared to raise \$25,000 for the purpose of purchasing an electric light plant. Underwood & Murphy, engineers, of Saskatoon, have advised that a 100 h.p. plant be installed but the council favors a 75 h.p. unit.

Alliston, Ont.—It is proposed to raise \$32,000 to provide for the taking over of the Alliston electric light plant and repairing and improving same for the purpose of distributing electric power to be supplied by the Hydro-Electric Power Commission of Ontario.

Longueuil, Que.—Permission has been given a few weeks ago to the Stowell Screw Co. to erect a factory on the corner of Montarville and St. Lawrence streets, but the council has recently received a letter from Dr. N. Jacques protesting against the factory being built. The matter will be discussed at the next Council meeting.

Aurora, Ont.—At a meeting of citizens held in the Town Hall here on May 2, E. C. James, civil engineer for the county, explained a suggested sewage system for the town, illustrating the plan with diagrams. The estimated cost of the improvement is \$80,000, and it was the opinion of the meeting that the matter should not be considered until after the war.

GENERAL

Hamilton, Ont.—The National Paper Goods Co. are building an addition to their factory.

Toronto, Ont.—De Laplante's planning mill at East Toronto is again in operation, the firm having secured an order for manufacturing a patent box.

Toronto, Ont.—A building permit has been issued to the Dominion Glass Co.,

for the construction of an addition to their factory to cost \$5,000.

Hamilton, Ont.—There was a fire on April 30 at the premises of the Laidlaw Bale Tie Co., when the cooper shop was totally destroyed. The loss will be about \$5,000.

Stratford, Ont.—At a meeting of directors of the National Portland Cement Co., it was decided to reopen the plant at Durham at once for the manufacture of cement, this time as a rock proposition. The works have been closed since June last. R. H. McWilliams of St. Marys, was again appointed manager.

North Bay, Ont.—The industrial by-law empowering the corporation to guarantee bonds of the J. P. Quinlan Manufacturing Co. to the extent of \$15,000 was carried by a large majority of the ratepayers last Monday. The company will manufacture furniture and church and school fixtures.

Nicet Mills Que.—On April 29 the pulp mill and sash and door factory here, of the Lotbiniere Lumber Co., were completely destroyed by fire. The building and machinery are a total loss. The property belongs to F. N. McCrea, M.P., and E. W. Tobin. The damage is placed at \$80,000, with but \$40,000 insurance.

PERSONAL

F. Tissington has resigned from the position of chief engineer of MacKinnon Holmes & Co., Sherbrooke, Que.

Capt. B. T. Eastaway, who had commanded several Allan liners, has been killed while in command of one of his Majesty's ships.

A. McL. Seeley, for several years general storekeeper of the Nova Scotia Steel & Coal Co., at Sidney Mines, has been appointed to the position of general purchasing agent, with headquarters at New Glasgow, N.S.

I. J. Tait, formerly chief engineer at the Windsor station, Montreal, has recently become associated with J. T. Farmer, sales representative for the Green Fuel Economizer Co. and the Combustion Engineering Corporation of New York.

J. T. Farmer, 314 Coristine Bldg., Montreal, who for several years has handled the Canadian business of the Green Fuel Economizer Co. of New York, has in addition to this, the agency for Canada, for the Combustion Engineering Corporation also of New York; this firm manufactures a line of underfeed stokers.

S. R. Sheldon, vice-president and chief engineer of Sheldon's Ltd., Galt, Ont., the well known manufacturers of heating and ventilating equipment, died suddenly last Monday after an operation for appendicitis aged 40. Mr. Sheldon was originally with the McEachren Ventilating Co. and about fifteen years ago took over the business with his brother W. O. Sheldon. The company was at a later date incorporated as Sheldon's Ltd.

TRADE GOSSIP

Montreal, Que.—Pulp mills of D'Alma Peribonka Pulp Co., at St. Joseph D'Alma, Lake St. John, has been sold to R. W. Barclay of Montreal and V. N. Theriault, of Nicolet, for about \$100,000.

Mackinnon, Holmes & Co., Sherbrooke, Que., have recently received an order for a quantity of steel bow plates to be used in connection with troop scows being built in Canada.

Extend Time for Loading.—The Standard Shipping Co. of Cleveland, Ohio, has arranged with the Canadian shippers to extend opening shipping period five days and boats loading to Fort William and Port Arthur will have fifteen days instead of ten days to report for cargoes.

Montreal, Que.—It is understood that the Aetna Chemical Co. of Drummondville have been advanced \$1,000,000 by the Imperial Munitions Board to serve as additional working capital. The Munitions Board have also agreed to increase the price of smokeless powder to 57 cents a pound.

Big Increase In Customs Returns.—Hon. J. D. Reid, Minister of Customs, announced to-day that the Customs revenue for April was \$14,149,156, compared with \$10,346,572 for April of last year, an increase of \$3,802,584. The increase noted is the largest for any month from Customs in the history of the country.

The Metal Manufacturers Service, have opened an office at 76 Sun Life Building, Toronto as a means of assisting jobbing machine shops in obtaining work. This concern will be glad to hear from owners of machine shops doing jobbing work in regard to size and capacity of their plants, particulars of machinery installed and class of work for which the shop is best adapted, number of mechanics employed and if they can take on any more work for early delivery.

Returns From Excise Duties Decline.—Receipts of the Inland Revenue Department during March last amounted to \$2,020,749, as compared with \$2,273,124 in the same month in 1916, a decrease of \$253,000, probably accounted for by the enactment of prohibitory laws in several provinces. Of the collections, \$1,819,135 represented the proceeds of excise duties. This included \$698,527 from taxes on spirits, \$10,043 from malt liquors, \$157,525 from malt, \$869,938 from tobacco, and \$63,115 from cigars. War tax collections in the department amounted to \$136,056 during the month.

Shortage of Tin Plate Affects Canneries.—Canadian canning factories are concerned over the fact that they have to depend on American companies to furnish the cans, and that this year the supply of cans in the conservation of tin, is much less than usual. American canneries are able to obtain only 40 per cent. of their usual requirements, and are intending to can only perishable goods. Where the Canadian factories will come off is not yet known

exactly, but they, too, will probably be able to use tins only for exceedingly perishable products. Cardboard paper machine and other manufactured containers are being suggested for some lines.

Work on Welland Canal Ceases.—Work on the Welland Ship Canal was completely closed down on May 2, when the services of all the engineers' staff were dispensed with. Including those of J. L. Weller, engineer in charge to whose initiative the building of this great work is due. The contracts for four sections, comprising about eleven miles of canal, and all the seven lift locks and amounting to about \$25,000,000, are about half completed. The contractors were instructed last January to close down all their works for a period of one year and at the end of that time a further period of closing down would probably be specified.

C.P.R. Orders Boats.—C.P.R. tonnage will soon be practically the same as before the war, and four additional ships will be placed on the stocks. The C.P.R. purchased at a cost of \$240,000 an ocean steamship of 9,400 tons carrying capacity, and a speed of thirteen knots, now under construction at Newcastle-on-Tyne. The ship will be delivered in July or August, and will make the tonnage of the company's ocean fleet practically the same as it was before the outbreak of war. In addition, however, the company has ordered two steamships of 605 feet in length, with a speed of twenty knots, and two more steamships of 546 feet in length, and a speed of sixteen knots, under a contract with John Brown & Co., Fairfield Shipbuilding Co., and Harland & Wolff.

Canadian Canals Traffic Increase.—A Government blue book tabled in the House at Ottawa on May 7, shows that there was an increase of 8,384,688 tons in traffic through Canadian canals during the season of 1916. The total volume of traffic last season was 23,583,491 tons, as against 15,198,803 in 1915. A great increase was shown in the traffic through the canal at Sault Ste. Marie. The total traffic through this waterway during the season of 1916 was 16,813,649 tons, as against 7,750,957 during the previous year. The traffic through the St. Lawrence canals during 1916 totalled 3,368,064 tons, and through the Welland Canal 2,544,964 tons. The total volume of wheat moved through the Soo Canal last season was 185,003,667 bushels, and of this quantity 82,807,342 bushels passed through the Canadian channel. The larger accommodation on the St. Mary's side of the river, says the report, probably accounts for the larger portion of the traffic going through the American channel.

Government Can Requisition Ships.—An Order-in-Council widening the powers of the Canadian Government to requisition ships under the authority of the War Measures Act is contained in a return tabled in the Commons on April

Warner & Swasey Screw Machines

Far large output and close limits – If you are figuring on screw machine work you can depend on W & S machines being right for the job.

We can supply you from stock immediately.

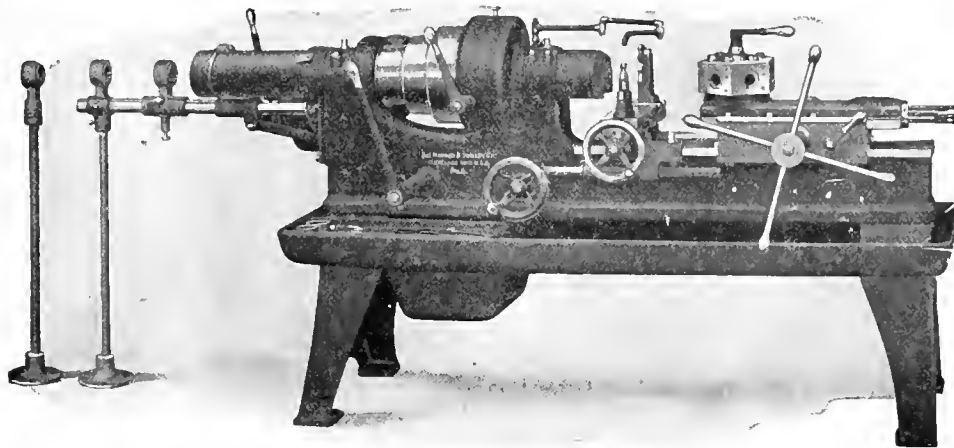

The A. R. Williams Machinery Company, Limited

ST. JOHN, N.B.
WINNIPEG, VANCOUVER

“If It’s Machinery, Write Williams”

64 Front Street West
TORONTO

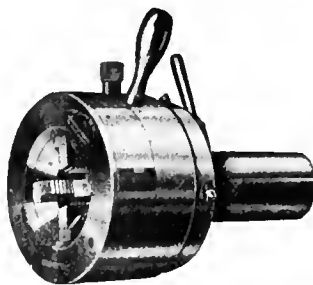

Geometric Self-opening and Adjustable Screw-cutting Die Head.

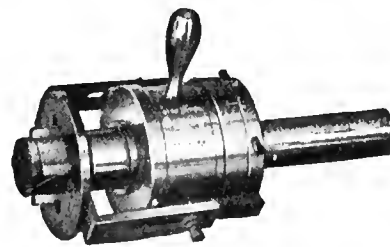

Geometric Adjustable Collapsing Tap.

Long Life and Good Work

A Shop Foreman Writes—

“Fifty Geometric Die Heads and Collapsing Taps in our plant. Long life and good work the reason.”

Where one Geometric Screw-Cutting Tool enters, others follow. If you want to know real thread-cutting satisfaction, let a Geometric in.

Whether it is an outside thread, or an inside thread, of whatever diameter, length, pitch or

form, a Geometric Screw-cutting tool will produce it. Whatever the make of your Screw Machine, a Geometric will fit it.

Let us know the class of thread-cutting that you have to do, and we will describe, for your consideration, the tool best suited to produce it.

The Geometric Tool Company, New Haven, Conn., U.S.A.

Canadian Agents:

Williams & Wilson, Ltd., Montreal. The A. R. Williams Machinery Co., Ltd., Toronto, Winnipeg, St. John, N.B.

If any advertisement interests you, tear it out now and place with letters to be answered.

PATENT ATTORNEYS

BABCOCK & SONS

ESTAB. 1877

PATENTS-TRADE MARK-DESIGNS
 IN ALL COUNTRIES

 Book "Patent Protection"—free. Master
 of Patent Laws, Formerly Patent Office
 Examiner.

 99 St. James St., - Montreal, Que.
 Branches: Ottawa, Washington.

RESEARCH BUREAU

 REPORTS BY EXPERTS ON SCIENTIFIC, TECHNICAL
 AND INDUSTRIAL DEVELOPMENT.

SPECIAL RESEARCHES ARRANGED.

PATENTS, TRADE MARKS, ETC.

HANBURY A. BUDDEN

CABLE ADDRESS

712 DRUMMOND BLDG., MONTREAL

"BREVET"

PATENTS

Fetherstonhansh & Co.
 Patent Solicitors. Head Office,
 Royal Bank Bldg., Toronto.
 Ottawa Office, 5 Elgin St.
 Send for our Plain Practical
 Pointers. Copy of National
 Progress, in which our patents
 are advertised, mailed free.

PATENTS PROMPTLY SECURED

 In all countries. Ask for our Investor's
 Adviser, which will be sent free.

MARION & MARION, 364 University St.
 Merchants Bank Building, corner
 St. Catherine St., MONTREAL, Phone Up. 6474
 and Washington, D.C., U.S.A.

MacKinnon, Holmes & Company, Limited

 Design, manufacture and
 erect all classes of Steel
 Work.

Specialties :-

Bridges
 Oil and Water Tanks
 Penstocks
 Coal and Coke Bins
 Smoke Flues & Stacks.

Prompt deliveries assured.

 Designs and Estimates from Head
 Office at

SHERBROOKE, QUE.

30. This order supersedes two earlier ones which were passed on November 24, 1916, and March 31, 1917. The order passed on April 24, provides that any vessel of Canadian registry, any ship under construction or to be constructed, even if exportation for foreign registry has been authorized, may be requisitioned by or on behalf of His Majesty for any purpose whatsoever. The new order also enacts that cargo space on any British ship registered in Canada may be requisitioned, in whole or in part, for any purpose whatsoever.

Old Machinery in Demand.—A Sarnia, Ont., despatch states that war conditions have created a demand for marine machinery of every description and boats which have been in marine graveyards for years are now being raised and stripped of their machinery, which is finding a ready market. Vessel men who long ago had charged their wrecks up to profit and loss are receiving large sums for abandoned machinery. During the last week at this port engines from the steam barge Benson, the tug's Constitution and Bielman, which have been on the bottom for years, have been recovered and they are in good shape. The Bielman's engine goes to New York and those from the Benson and Constitution to Cleveland. engine of the burned steamer Majestic, which was salvaged by the Reid Wrecking Co., also has been sold. Eastern vessel men say they have scoured every port for abandoned machinery. Plants which have been manufacturing small engines are now engaged in munition business, which is the reason why the old engines are in demand.

TENDERS

St. Lambert, Que.—Tenders will be received up to May 28, for the supply and installation of a horizontal shaft centrifugal pump, electric motor and switchboard. Specifications may be obtained from H. A. Gibeau, town engineer, St. Lambert, Chambly Co., P.Q.

Toronto, Ont.—Tenders will be received at this department up to May 16, for the building of a canning factory at the Experimental Fruit Station, Jordan Harbor. Plans can be seen at the office of the director, Jordan Harbor, and at this department. H. F. M'Naughten, Secretary Public Works Dept., Toronto.

Trenton, Ont.—Tenders will be received until May 15, for the erection of a nine-roomed Collegiate Institute in the town of Trenton, Ont. Plans and specifications may be seen at the Architect's office or at the office of C. W. Saylor, Chairman of Committee, Trenton. All information, tender forms, etc., may be had at the office of S. B. Coon and Son, Architects, Excelsior Life Building, Toronto Street, Toronto.

Winnipeg, Man.—Tenders for the additions to the city light and power plant at Point du Bois, decided on in January by the city council, are to be called at once and will close May 15, so that no time will be lost in taking advantage of the summer working season. The new

work which will include the installing of generators sufficient to carry the constantly increasing load for many years to come, will cost approximately \$180,000.

Dungannon, Ont.—Tenders, addressed to the undersigned, will be received up to May 12, for the material, plant and equipment of the Ontario West Shore Railway between Goderich and Kincardine. The material is practically all on the right-of-way, and consists approximately of six pairs of steel bridge girders for bridges of 25 ft. to 70 ft. spans; 2,400 cedar fence posts, 8 ft.; 710 boxes of spikes (about 324 lbs. to box); 135 boxes of bolts (about 125 lbs. to box); a large quantity of fish-plates; one engine, three flat-cars, scrapers, etc., used in construction work; a quantity of square timber, from 8 ft. to 24 ft. long; about 2,000 feet of 2 in. hardwood plank; about 900 tons of 70-lb. steel rails; also fourteen miles of track of 70-lb rails, bolts, spikes, fish-plates, ties, bridges, etc., laid complete. For further particulars apply to the trustee, Thomas Stothers, Dungannon, Ont.

MARINE

Port Colborne, Ont.—Dewitt Carter, president of the Welland Canal Tug Co., has completed the sale of the two tugs, Alert and Escort, to the Montreal Transportation Co. The tugs will continue towing in the Welland canal.

Captain R. C. Brown, of the Donaldson liner Cassandra, received the Harbor Commissioners' gold-headed cane, by reason of his having opened the 1917 season of ocean navigation to Montreal on May 1, his vessel coming into port early on that date.

Victoria, B.C.—Work is progressing rapidly on the G.T.P. steamer Prince Rupert at Esquimalt, where the vessel is drydocked. Messrs. Yarrows, Ltd., have a large gang of men at work and the steamship will be made ready for service again as quickly as possible.

St. Catharines, Ont.—Str. Natironco, owned by A. B. McKay of Hamilton, on May 3 carried away two head gates of Lock 3, Welland Canal. The freighter was upward bound when something went wrong with the engine. The damage is estimated at between \$2,000 and \$3,000.

St. Catharines, Ont.—The steamer Natironco, owned by A. B. McKay, of Hamilton, on May 3, carried away two head gates of Lock 3, Welland Canal. The freighter was upward bound when something went wrong with the engine. The damage is estimated at between \$2,000 and \$3,000. The pairs were completed on the head gates on May 4, and traffic resumed.

Steamer "G. A. Richardson" Sold.—Marvin M. Marcus, vice-president of the Great Lakes Transit Corporation, in charge of finance, announces that he has sold the steamer Granville A. Richardson to the Lake Transportation Co. of Mentor, Ohio, with offices in Cleveland. James Playfair, of Midland, Ont., is president and general manager of the company.

The Richardson has been at Buffalo fitting out ready for service.

Ships of Ferro Concrete.—Advices from Norway say that an experiment is about to be made with two motor ships, the hulls of which are constructed of ferro-concrete, to test the fitness of such vessels for North Sea trade. The boats will be of 1,000 tons and 600 tons, respectively. Ferro-concrete lighters have been used successfully for some time in Swedish coast traffic. The Norwegian boats can be built in four or five months and are cheaper than those of steel or wood.

Brockville, Ont.—In the presence of 1,000 spectators the new excursion steamer John Webster was about to be launched at Morristown, when the cribbing of the ways slipped as the new craft was fifteen feet toward the river. The boat settled on land, and all efforts to release it failed. The boat was christened by Miss Clara Garvin, and short speeches were delivered by Mayor Wright, W. A. Lewis, Brockville; A. W. Gregory, F. W. Ames, J. V. Crawford, R. Nielson and Rev. Mr. Hay, of Morristown. The Webster was built at a cost of \$25,000, and is named after Brockville's Federal member. She is 106 feet over all and 26 feet beam. On May 4, success attended the launching effort.

Less Meat on Ships.—Members of the Lake Carriers' Association are to do their part toward conservation of the food supply by urging greater economy in the use of foodstuffs on their vessels. A circular prepared by President William Livingstone, and sent to members of the Association, is being transmitted to their vessels. The communication is in part as follows: "The crews of our ships should line up with the housewives of the country, and serve the nation by eliminating all waste of foodstuffs and reducing the consumption of meat. Do you think in these critical times it is necessary to serve meat four times a day, as has become the practice on our lake ships? I appeal to you and to the crews on your ships to practise strict economy by not wasting a particle of food, and intelligently reducing the meat consumption on ships."

CONTRACTS

Regina, Sask.—The Poole Construction Co. has been awarded the contract for erecting a school building at \$18,220.

Toronto, Ont.—All the contracts have been let in connection with the \$200,000 office building for the Toronto Harbor Commission.

Peterborough, Ont.—The Quaker Oats Co. have awarded the contract for the rebuilding of their factory here, to the Canadian Leonard Construction Co., for \$500,000.

Quebec, Que.—The Eastern Canada Steel & Iron Works of St. Malo, have been awarded the contract for the steel work for the grain storage building for the Quebec Harbor Commissioners. The

**TRY HAMILTON
BABBITTS**
We Make Nothing Else
GEO. E. JOBBORN, Hamilton, Ont.

THE IRON WORKS LIMITED
Successors to
Owen Sound Iron Works
Owen Sound, Ont.
Engineers
Boiler-makers
Founders
Machinists

Tank Work
Smoke Stacks,
Grey Iron and
Brass Castings,
Special
Machinery
Made to
Order

**METAL
STAMPINGS**

We are manufacturers of stamped parts for other manufacturers.

We do any kind of sheet metal stamping that you require. Our improved presses and plating plant enable us to produce the finest quality of work in a surprisingly short time.

We can finish steel stamping in Nickel, Brass or Copper.

Send us a sample order.

W. H. BANFIELD & SONS
372 Pape Avenue, Toronto, Can.

**"HAWK" D
CHROME
VANADIUM
STEEL**



Will
Give You
Exceptional

**Shell Forging
Production**

WITHOUT AN EQUAL FOR BOTH FIRST AND SECOND OPERATION PUNCHES.

Comes to you heat-treated and ready for use. It does not stick to the work.

There are many cases where each punch has turned out over 2,000 shells. It means more shells, per machine per day.

STEEL OF EVERY DESCRIPTION.

**Hawkrige Brothers
Company**
303 Congress St., BOSTON, MASS.
U. S. A.

Let CANADIAN
MACHINERY Sell
It for You.

Cameron Babbitt Retainer
(Patented in Canada and the U.S.A.)

Not like clay or other material, as it does not stick to the work or hands. Does away with using leather or paste-board at end of box. For any metal.

The only satisfactory compound for retaining molten metal and can be used over and over again for months—no deterioration. For prices and samples apply to

A.S.K. Chemical Company, Elora, Ontario

3 BIG REASONS WHY YOU NEED

PURO

(MADE IN CANADA)

1. Puro Sanitary Drinking Fountains will give you a better water supply cheaper.
2. Puro will cut your water bills 15% to 35%.
3. PURO will safeguard the health of your employees and raise the standard of efficiency.

Are not these reasons enough? Then why hesitate longer? PURO equipment is not expensive—the first cost is low and the up-keep nothing. Easily attached; positively fool-proof. Let us make you a special proposition for a try-out in one of your departments. Write us now—to-day—giving us the number of men; an inquiry will cost you nothing.

"PURO - FY"

YOUR WATER SUPPLY

Puro Sanitary Drinking Fountain Company

143 University Ave.
TORONTO, CANADA

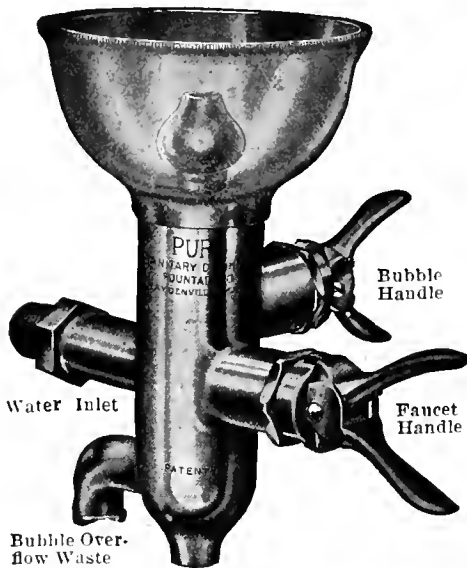

contract price is \$275,000. The George Fuller Co., are the general contractors.

The Ford-Smith Machine Co., Hamilton, Ont., have received an order from Alfred Herbert, Ltd., of Coventry, England, for seventeen milling machines, twelve No. 2, and five No. 3 millers. This is a repeat order and was placed on account of the very satisfactory service given by the machines on the original order, in aeroplane and automobile factories in Great Britain and France. The machines before acceptance were subjected to a rigid examination.

Shipping Board for Canada.—Legislation, with object of promoting and making permanent the shipbuilding industry in Canada, is to be brought down by the Government this session. At present Canadian shipyards are working to full capacity, but the orders placed through the Munitions Board are more essentially due to the urgent situation now existing. What is proposed is a plan which would make for the permanent maintenance of the industry by a programme of Government assistance through loans or subsidies. Quite probably a shipping board will be created to assume general direction of the scheme.

RAILWAYS—BRIDGES

Toronto, Ont.—The Dominion Railway Board has issued a judgment in favor of the C.P.R. application to be allowed to build a double-deck bridge over the Summerhill avenue ravine.

Lethbridge, Alta.—Engineers for the Alberta-Hudson railway are now working in the south, on preliminary routes for the proposed extensions of the line, a charter for which was granted at the last session of the legislature. R. D. Fry is the engineer in charge in the south and has already run preliminary surveys for the proposed line from Pincher Creek to Cardston, thence to Coumts and on to Medicine Hat. From a point near Cardston a survey for the line into into Lethbridge will be made.

CATALOGUES

Universal Turret Lathe.—Catalogue just off the press describes the No. 1 Universal turret lathe made by the Foster Machine Co., Elkhart, Ind. The catalogue contains a full description of this turret lathe together with complete specification and illustrations showing the general design of its principal features. The tools and attachments used on this machine are also illustrated and fully described.

"Diamond Soot Blowers for Babcock & Wilcox Boilers." is the title of the attractive and interesting Bulletin-125 just recently issued by the Diamond Power Specialty Co., of Detroit, Mich. It contains the statement from the Babcock & Wilcox Co., explaining why that company has adopted "Diamond" soot blowers as standard equipment for all boilers it builds. The descriptive matter regarding the application of the mechanical soot blower to B. & W. boilers is clearly illus-

trated by pictures and drawings. The installation of mechanical soot blowers on the 2365 h.p. double Stirling boilers at the Detroit Edison Co.'s Connors Creek plant is one of many interesting illustrations shown. A copy of the bulletin will be sent free to anyone requesting it.

Whiting Cranes.—Of all types and for every service are described and illustrated in catalogue 127 recently issued by the Whiting Foundry Equipment Co., Harvey, Ill. The opening pages of the catalogue deal with electric traveling cranes illustrating and describing the latest features in Whiting crane construction. Following are brief descriptions of hand power, locomotive and cranes accompanied by illustrations showing the various types. The second half of the catalogue shows several typical illustrations of whiting cranes of various sizes and capacities in different classes of service. These views represent a wide field of service covered and are shown with the object of assisting purchasers to select the proper types.

Modern Steam Disinfection is the title of a catalogue issued by the Grampian Engineering Co., Stirling, Scotland, and featuring the "Velox" steam disinfectors for hospitals and military camps, etc. The catalogue is arranged in two main sections. The first part compares various methods of physical disinfection explaining the development of the steam process and its principal features. Then follows a full description of the "Velox" apparatus including details of construction covering both high and low pressure disinfectors. The combined high-pressure steam and vacuum-formalin process is then dealt with fully with method of operation. The second part of the catalogue contains a representative list of standard types and sizes of the "Velox" steam and combined disinfectors. The various types, stationary, portable and marine are described and illustrated; the class of work for which each type is recommended. A report of tests concludes a well arranged catalogue.

Abrasive Grinding Wheels is the title of an attractive new catalogue No. 6, issued by Abrasive Company, Philadelphia, Pa. The catalogue contains an extensive list of special shaped abrasive grinding wheels for miscellaneous grinding machines. The wheels are classified and illustrated with principal dimensions and price given for each size. Straight, cup and cylinder wheels are also listed, accompanied by rules for calculating list prices. A chapter is devoted to the use and care of wheels, followed by a set of rules for calculating speeds. The principal points involved in the process of manufacture of these wheels, which are made of boro-carbone and electroton, are briefly described. A table for selection of grain and grade for various classes of work is a useful feature of the catalogue and one of considerable help when ordering. The catalogue contains telegraph and cable codes and general index. Copies may be obtained from the Canadian distributors, the Canadian B. K. Morton Co., Toronto and Montreal.

"Barnes-Made" SPRINGS

are unusual in service and wear

They are the result of sixty years' experience, unsurpassed equipment and highly skilled workmanship.

A trial will convince you that "Barnes-Made" Springs are the best buy.

Established 1857.

THE WALLACE BARNES COMPANY

218 South St., Bristol, Ct., U.S.A.
Mfrs of "Barnes-made" Products
Springs, Screw Machine Products, Cold Rolled Steel and Wire

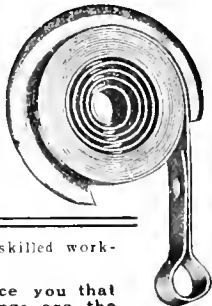

Gun-Crete.—The Cement-Gun Construction Co., Chicago, Ill., have issued a bulletin No. 5 containing a number of illustrations of "Gun-Crete" work which they have executed. The bulletin explains what Gun-Crete is and the method of application while the illustrations show the wide range of work where it has been used.

Fifteen Years on Brine Lines is the title of a bulletin being distributed to the trade by the Armstrong Cork and Insulation Co., Pittsburgh, Pa. The bulletin refers to a number of instances as indicated by the title and explains the saving in refrigeration on this account. Copies may be obtained from the Canadian office of the company, 504 McGill Building, Montreal.

Drilling Machines.—Catalogue dealing with an interesting line of high speed, belt driven, ball-bearing, drilling machines. Each type is illustrated and specifications give the principal dimensions and other particulars. The concluding page contains important notes for the guidance of purchasers. The catalog is issued by the Langelier Manufacturing Co., Providence, R.I.

Hill Clutch Equipment is the title of a bulletin, the first of a series, describing and illustrating installations of friction clutches, collar oiling bearings, rope drives, etc., the product of the Hill Clutch Co., Cleveland, Ohio. This bulletin, April issue, deals with a complete installation of moderate power distribution made by the company, accompanied by interior views of the factory. Copies of the series will be gladly sent to readers interested in power transmission machinery equipments upon receipt of name and address.

BOOK REVIEWS

The British Dominions Year Book 1917.—Published by the British Dominions General Insurance Co., Ltd., London, England. The year book for 1917 contains as usual a number of interesting articles contributed by well known writers covering the great war and matters affecting the well-being of the British Empire. The subjects have been carefully chosen and are particularly appropriate at the present time in that they deal with questions connected with both the military and economic aspect of the situation. Without making any invidious distinctions the following may be mentioned as being a few of the more interesting subjects dealt with. The Aftermath of the War; The War's Three Phases, A Year of Naval War, India's Future in the Empire, Foreign Policy, International Law, Agricultural Outlook, War Finance, National Insurance, Aircraft in the War, etc. In addition to the main subjects the Year Book contains other interesting matter of diverse nature including numerous statistics and reports. The book contains 308 pages with a number of colored plates inter-leaved and shows orders and decorations, regimental colors, house flags and several maps.

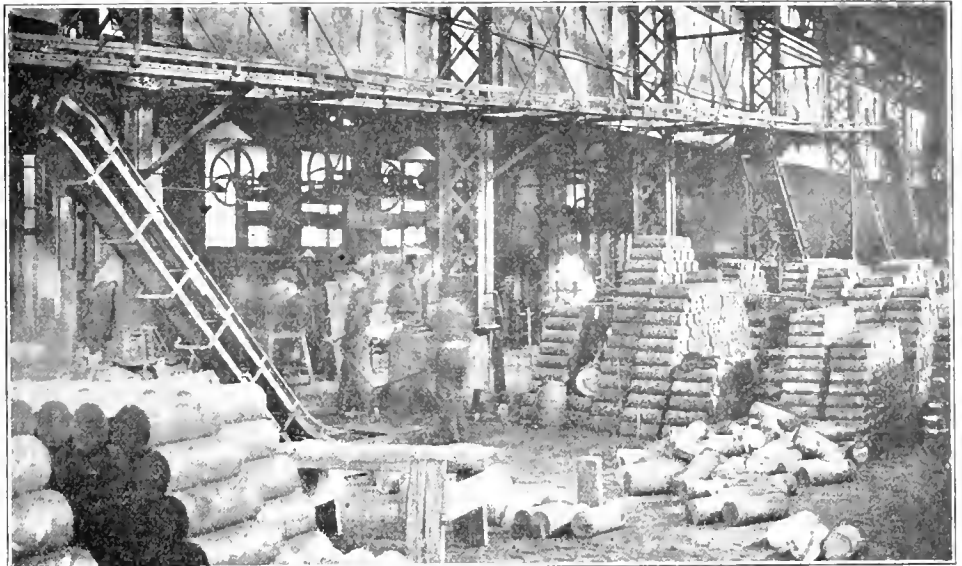

Steel Shell Forgings or Billets of any size or weight will move any distance or about curves upon our specially constructed Gravity Carriers and Incline or Horizontal power devices. No labor required.

Canadian Mathews Gravity Carrier Co., Toronto, Ont.

MORTON MANUFACTURING CO.
 PORTABLE PLANERS
 DRAW CUT SHAPERS
 SPECIAL DRAW CUT R R SHAPERS
 FINISHED MACHINE KEYS
 STATIONARY & PORTABLE KEY WAY CUTTERS
 SPECIAL LOCOMOTIVE CYLINDER PLANERS
 OFFICE AND WORKS: MUSKOGON HEIGHTS USA

OVENS
 Enameling and Varnishing Ovens heated by Gas, Electricity, Steam or Coal.
 Write for Booklet.
Brantford Oven & Rack Co., Ltd.
 Brantford, Canada.

Over the Page

you'll find a number of small items, some of which will most certainly interest you. Every week there are opportunities galore offered there.

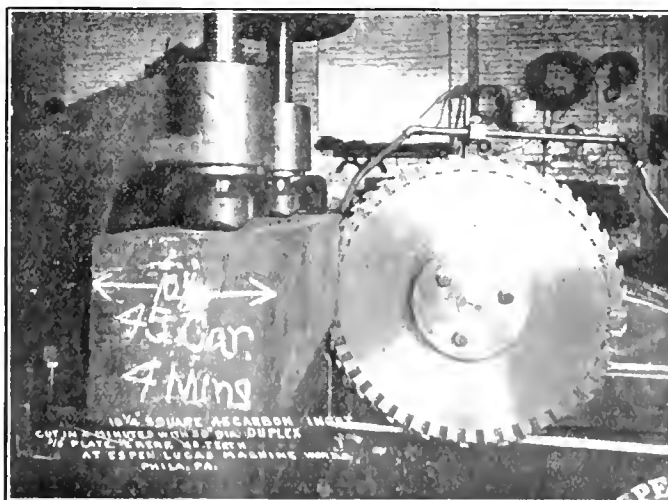

Circular Metal Cutting Saw Blades for Any Type of Machine

Let us demonstrate what a saving can be made by installing a **HUNTER "DUPLEX" Inserted Tooth Blade**

Write for information
HUNTER SAW & MACHINE CO., Pittsburgh, Pa., U.S.A.

CLASSIFIED ADVERTISING

Rates (payable in advance): Two rents per word first insertion; one cent per word subsequent insertions. Count five words when box number is required. Each figure counts as one word. Minimum order \$1.00. Display rates on application.

SECTION

FOR SALE

ONE 20 H.P. MOTOR, IN GOOD CONDITION. Spartan Machine Co., Lt., 1112 St. Patrick St., Montreal. c21m

FOR SALE.—ONE 8 x 8 AIR COMPRESSOR with unloader and reservoir complete.—Apply Canadian Hart Wheels, Limited, Hamilton, Ont. c18m

FOR SALE—ONE LEWIS TYPE ENGINE built by Waterous Engine Works, 240 H.P., flywheel 73" x 18", automatic governor, a bar-rain. One steam pump, 4½" x 2¾" x 4". Write Box 217, Moncton, N.B. c24m

ONE 4.5" LEES-BRADNER THREAD MILLER—in first-class condition. For milling threads in nose of shell. Spartan Machine Co., Ltd., 1112 St. Patrick St., Montreal. c20m

FOR SALE.—ONE 10' BED, 10½" SWING, Crosby SS Screw Cutting Engine Lathe, or will exchange for 40" Gap bed lathe.—Apply Canadian Hart Wheels, Limited, Hamilton, Ont. c18m

1—GISHOLT LATHE 24" SWING, 6' BED, with turret head and three-jaw chuck. 1—Gisholt lathe, same as above, 20" swing, 6' bed. 1—4.5 Brown, Boggs marking machine. Jenckes Machine Co., Sherbrooke, Que. c20m

FOR SALE—ONE 450 H.P. THOMPSON & Williams condensing engine. Will sell cheap. Engine is in first-class repair and will give every satisfaction. Apply J. A. Marven, Limited, Moncton, N.B. tcfm

ONE LATHE 16" x 4½" BACK-GEARED—Built by P. P. Silk Machine & Tool Co., Cincinnati, Ohio. One lathe 18" x 3", back-geared. Built by the Bradford Mill Co., Cincinnati, Ohio. Four Murchey collapsible dies. Capacity 1½" to 2½". Box 272, Canadian Machinery. ctmf

1 16" x 14" "WATERTOWN," CENTER crank, four-valve engine; flywheel 66" diameter, 14" face; direct connected to 100 K.W., 6 pole, 220 volt General Electric direct current generator, complete with cast iron sub-base under engine; gravity oiling system and force feed lubricator. Delivered f.o.b. cars, Stellarton, N.S., \$3,600. The above outfit is in perfect working condition, is as good as new, having been in operation less than two years. Shipment can be made in one week. Albion Machine Co., Limited, New Glasgow, N.S. c21m

1 ENGINE LATHE, 22" SWING, 36" CENTER to center, geared 18 to 1, arranged for shell turning, with two straight turning tools and one profile turning tool. 1 Gisholt lathe, 30" swing, with turret head and chuck. 1 Engine Lathe, 14" swing, 30" long, with steady rest, face plate and countershaft, suitable for screw cutting. 1 Potter & Johnston Automatic Turret Lathe, 19" swing, 1 Turret Gap Lathe, 24" swing over bed, 40" over gap, 9' long over all, with turret for six tools. 1 Power-driven Plate Planer, 9' 9" long, screw feed. 1 Brown, Boggs Marking Machine, for 4.5" shell. 1 Band Press, air operated, for 4.5" shell. 3 Sand Blast Tanks. Jenckes Machine Co., Sherbrooke, Que. c20m

WANTED

WANTED—THE ADDRESS OF A MANUFACTURER of crude oil or kerosene engines, for export. Semi-Diesel type preferred. Address Box 301, Canadian Machinery. c18m

SUBSTANTIAL LOCATION IS DESIRED FOR an iron working plant, especially where liberal financial assistance can be secured for a worthy enterprise. Address Box 302, Canadian Machinery. c18m

WANTED—WHAT HAVE YOU TO OFFER in heavy turret lathe, suitable for boring 4.5 shells? State whether new or second-hand, maker's name, dimensions, condition of service and equipment if any. Wire reply to Medicine Hat Pump & Brass Mfg. Co., Ltd., Medicine Hat, Alberta. c19m

SPECIAL MACHINERY

MANUFACTURERS—WE CAN UNDERTAKE work to any specification—munition production equipment or otherwise. Write W. H. Sumbling Machinery Co., 7 St. Mary St., Toronto.

O. E. WOODS—GENERAL MACHINE SHOP—builders of special machinery. Will do well to use our experience and equipment. We are prepared to make special machinery, punches and dies, jigs, fixtures and tools to any specifications and drawings. Get our price and promise of delivery. Phone Gerrard 960. Address 754 Broadway Ave., Toronto, Ont.

SITUATIONS VACANT

WANTED—GENERAL FOREMAN FOR MACHINE shop on 6-inch Mark III. shell production. Must be holding similar position, have initiative and able to push production. To such a man every encouragement will be given. Box 308, Canadian Machinery. c21m

One Advertiser Said To Us—

"One insertion of this ad will do"—when sending in copy for a condensed ad. This firm sends in from three to four ads a month, so they ought to know.

While two or three insertions give your proposition more chance to be considered, still this incident shows just what advertisers know this section will do for them.

Use its service now—every time you need it.

Canadian Machinery

Classified Advertising Section

143 University Ave., Toronto, Ont.

BUSINESS CHANCES

SPLENDID OPPORTUNITY FOR MANUFACTURER to locate in town with water and trans-continental railway connections. Large cement factory with equipment and good water power, ready for operation; also large piece of land for extension purposes. To encourage a good, live manufacturing concern, special concessions will be given. All inquiries treated confidential. State nature of business when replying. Apply P.O. Box 533, Montreal. c19m

FOR SALE—A MEDIUM-SIZED TWO-STORY brick factory situated in the best small city in Ontario. Buildings in good condition, suitable for either metal or wood-working; shipping facilities unexcelled. Two trunk lines; direct connections east, west, north and south. Educational advantages the very best. Plant will be sold at a bargain and on easy terms of payment, if desired. Apply Box 294, Canadian Machinery.

SITUATIONS WANTED

WANTED—POSITION AS PURCHASING MAN or salesman. Have thorough knowledge of hardware, mill supplies, carbon and high speed steels, tools etc.; age 34; married; ambitious.—Box No. 307, Canadian Machinery. c20m

STEEL FOUNDRY EXECUTIVE, CANADIAN, with fifteen years' experience with most up-to-date plants in United States, seeks similar position in Canada. Thoroughly conversant with sales, operation and business management. Box 306, Canadian Machinery. c22m

PRACTICAL WORKS MANAGER AND MECHANICAL expert with years of experience in United States and Canada, a specialist in munition work, open for engagement. Best of references. Apply Box 304, Canadian Machinery. c23m

ELECTRICAL ENGINEER—COLLEGE GRADUATE, five years' practical experience; now employed in large industrial plant, electric-driven; responsible position desired; money not sole object; recommendations. Box 305, Canadian Machinery. c21m

SITUATIONS VACANT

FOREMAN PATTERNMAKER—MUST BE OF first-class; man experienced on engine, mining and general contracting machinery patterns. Write fully, Box 298, Canadian Machinery. ctmf

WANTED—SALESMEN TO SELL BABBITT metals on commission as side line. Good commission. Give full particulars as to firms represented and territory covered. Box 303, Canadian Machinery. c21m

MECHANICAL ENGINEER WANTED—FIRST-class opportunity for the right party. Must be energetic, ambitious, sober and have some knowledge of French. Apply Box 286, Canadian Machinery. tcmf

TOOL STEEL SALESMAN—ONE WITH knowledge of the business preferred. State age, whether married or single, experience. No application will be considered unless full details are given. Box 300, Canadian Machinery. c20m

A GOOD SALES ENGINEER TO OPEN OFFICE to sell Moline heat in Canadian territory. Must be a good salesman, having had a general heating and ventilating experience. Must give good references. We have a fine proposition for the right man. Address Moline Heat, Moline, Ill. ctmf

CANADIAN MACHINERY

AND MANUFACTURING NEWS

A weekly newspaper devoted to the machinery and manufacturing interests.

Vol. XVII.

TORONTO, MAY 17, 1917

No. 20

EDITORIAL CONTENTS

High Explosive Shell Manufacture	499-504
Equipment, Methods and Devices for Machining 6-inch Shell.	
Production Methods and Devices	505-508
Oil Burner for Shell Furnaces.	
Time-Saving in Machine Shop Practice.	
Taper Turning Attachments to Boring Mill.	
Steel Hands for Machinists.	
Screw Thread Measurement.	
Simple Taper Turning Attachment.	
General	508-509
Saving Steel in Shipbuilding.	
Ship Plate Manufacture in Canada.	
Use of Glue in Steel Polishing Industry.	
Editorial Correspondence	510-512
Notes on Non-Ferrous Metals for Ordnance Work.	
Machining Recuperator Details for Field Guns.	
Fabric Brake and Clutch Linings.	
The Effect of Storage on Coal.	
Standardization Applied to Cargo Boat Machinery.	513-515
Progress in New Equipment	516-517
Revolving Machine Standard.	
Plate Punch Table.	
Universal Cutter and Tool Grinder.	
General	517
Turbine Gearing.	
Editorial	518
Canadian Steel Corporation Activity.	
Best Ship Size to Meet the Emergency.	
Industrial Notabilities	519
Louis Marcel Lymburner.	
Selected Market Quotations	520-521
The General Market Condition and Tendency	521-524
Summary.	
Montreal Letter.	
Toronto Letter.	
Sydney Letter.	
Industrial and Construction News	525-526

THE MACLEAN PUBLISHING COMPANY, LIMITED

JOHN BAYNE MACLEAN, Pres. H. T. HUNTER, Vice-pres. H. V. TYRRELL, Gen. Man.

Publishers of Hardware and Metal, The Financial Post, MacLean's Magazine, Farmer's Magazine, Canadian Grocer, Dry Goods Review, Men's Wear Review, Printer and Publisher, Bookseller and Stationer, Canadian Machinery and Manufacturing News, The Power House, The Sanitary Engineer, Canadian Foundryman, Marine Marine Engineering of Canada.

Cable Address: Macpubco, Toronto; Atabek, London, Eng.

ESTABLISHED 1887

CANADIAN MACHINERY

AND MANUFACTURING NEWS

PETER BAIN, M.E., Editor. B. G. NEWTON, Manager.
Associate Editors: A. G. WEBSTER, J. M. WILSON, J. H. RODGERS.

CHIEF OFFICES:

CANADA Montreal, Southam Building, 128 Bleury Street, Telephone 1001, Toronto, 143-153 University Ave., Telephone Main 7321; Winnipeg, 22 Royal Bank Building, Telephone Garry 2313.

GREAT BRITAIN LONDON, The MacLean Company of Great Britain, Limited, 88 Fleet Street, E.C., E. J. Dodd, Director, Telephone Central 12960, Cable Address: Atabek, London, England.

UNITED STATES New York, R. R. Huestis, Room 629, 111 Broadway, N.Y., Telephone Rector 8971, Boston, C. I. Morton, Room 733, Old South Building, Telephone Main 1201, A. H. Byrne, 1101-5-6-7 Fort Dearborn Bldg., 105 W. Monroe St., Chicago, Telephone Randolph 323.

SUBSCRIPTION PRICE Canada, Great Britain, South Africa and the West Indies, \$3.00 a year, United States, \$3.50 a year; other countries, \$4.00 a year; Single Copies, 15 cents. Invariably in advance.

Built To Cope With Modern Ways

To meet with the demands of the day successfully the Crank Shaper must be a machine that can take care of a variety of work with the least adjustment.

THE HENDEY CRANK SHAPER

Has been carefully studied in every detail of its design in order to furnish a shaper equal to all present-day needs.

Write for complete description of this profit-making machine.

Hendey Machine Co. TORRINGTON, CONN. U.S.A.

Canadian Agents: A. R. Williams Machinery Co., Toronto, Ont.; A. R. Williams Machinery Co., 260 Princess St., Winnipeg, Man.; A. R. Williams Machinery Co., Vancouver; A. R. Williams Machinery Co., St. John, N.B.; Williams & Wilson, Montreal.

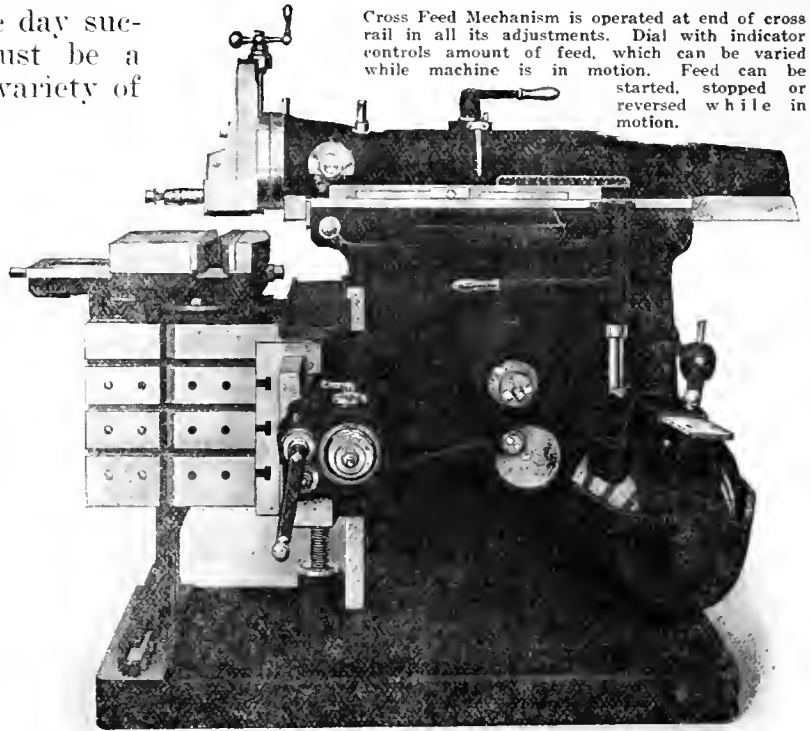

Cross Feed Mechanism is operated at end of cross rail in all its adjustments. Dial with indicator controls amount of feed, which can be varied while machine is in motion. Feed can be started, stopped or reversed while in motion.

INDEX TO ADVERTISERS

Adams, Ogden R.	126	Cushman Chuck Co.	105	Johnson Mach. Co., Carle	8	Rickett-Shafer Co.	91
Aikenhead Hlwe. Co.	85	D		Joyce, Geo. A. Co.	114	Richmond Mfg. Co.	97
Armstrong Bros. Tool Co.	13	Davis-Bourneville Co.	103	Kemp Smith Mfg. Co.	27	Riverside Machy. Depot	71, 73
Armstrong, Whitworth of Canada	7	Davis, W. F., Machine Tool Co.	77	L'Air Liquide Society	82	Rivett, Lathe & Grinder Co.	122
A.S.K. Chemical Co.	69	Delano Smelting & Refining Co.	25	Landis Machine Co.	103	Rockford Drilling Machine Co.	115
Atkins, Wm., & Co., Ltd.	15	De Mooy Mach. Co.	115	Larrobe Elec. Steel Co.	9	Rockwell Co., W. S.	104
Atlas Crucible Steel Co.	10	Dominion Forge & Stamping Co.	106	Lynd-Parquhar Co.	72	Rodolofson Machine & Tool Co.	19
Aurora Tool Works	115	Dominion Iron & Wrecking Co.	84	M		Roper & Co., C. F.	87
B		Dominion Machinery Co.	75	Maenab, John, Machy. Co.	21	S	
Babeock & Sons	66	Dominion Steel Foundry Co.	102	Marion & Marion	70	Shore Instrument Co.	105
Baird Machine Co.	105	E		Manufacturers Equipment Co.	97	Shuster Coy. F. B.	102
Banfield, E. J.	16	Eastern Mach. Screw Corp.	98	McCabe, J. J.	76	Silvey Tool Co.	Inside back cover
Banfield, W. H., & Sons	19	Elmes, Chas. F.	89	McCoy-Brandt Machy. Co.	72	Silver Mfg. Co.	104
Barnes, W. F., & John	117	Eric Foundry Co.	111	McKinnon Dash Co.	71	Skinner Chuck Co.	13
Barnes, Wallace, Co.	117	F		McLaren, J. C., Bolting Co.	102	Slocum, Avram & Slocum	28
Bath & Co., Cyril J.	75	Fatherstonhaugh & Co.	66	Mechanical Engineering Co.	117	Standard Alloys Co.	10
Beatty & Sons, M.	73	Fitzgerald, W. H. J.	72	Metalwool Mfg. Co.	117	Standaud Elec. Tool Co.	29
Beaudry & Co., Inc.	74	For-Smith Mach. Co.	25	Metals Coating Co.	78	Starret Co., L. S.	85
Bertram, John, & Sons Co., Ltd.	1	Foss & Hill Machy. Co.	75	Metal Manufacturers' Service	79	Steecher Co., Chas.	21
Bilton Mach. Tool Co.	16	G		Michigan Steel Exchange, Inc.	14	Steel Co. of Canada	3, 73
Brantford Oven & Rack Co.	69	Galt Mach. Screw Co.	83	Milners Falls Co.	94	Stephoe, John, Co.	82
Bridgeford Mach. Tool Works	5	Garlock-Walker Mac. Co.	105	Milhollan Co., W. K.	23	Stocker-Rumley-Wachs Co.	77
Bristol Company	102	Garvin Mach. Co.	24	Monarch Brass Mfg. Co.	79	Stone Tool & Supply Co., J. R.	98
Brown, Bozes	11	Geometric Tool Co.	13	Montreal Machy. & Supplies	69	Star Mfg. Co.	95
Brown & Shaime	119	Gay Instrument Co.	119	Morton Mfg. Co.	66	Starvant Co., B. F.	91
Brownell Machy. Co.	72	Gillett & Barker Co.	119	Murhey Machine & Tool Co.	90	Swedish Grage Co., Inc.	85
Brown's Copper & Brass Rolling Mills	65	Globe Machine & Stamping Co.	80	N		Swedish Steel & Importing Co.	9
Budin, Hamby A.	67	Go-Land Tool Co.	81	Napier Saw Works, Inc.	104	T	
Butterfield & Co., Inc.	111	Gooley & Ellund, Inc.	24	National Acme Co.	21	T. C. M. Mfg. Co.	84
C		Grant Mfg. & Machine Co.	111	National Machine Tool Co.	105	Tabor Mfg. Co.	105
Canada Machinery Corporation	Outside back cover	Grant Gear Works, Inc.	104	New Britain Mach. Co.	69	Tare, Jones & Co., Inc.	115
Canada Wire & Iron Goods Co.	78	Greenfield Machine Co.	105	New York Machinery Exchange	94	Taylor Instrument Co.	119
Can. B. K. Morton Co.	7	H		Nick-Bornet-Ponl.	Inside front cover	Thwing Instrument Co.	121
Can. Bond Hanger & Coupling Co.	7	Hamilton Edge & Machine Co.	78	Noble & Westbrook Co.	17	Toronto Iron Works	102
Can. Bridge Co., Ltd.	72	Hamilton Machine Tool Works	23	Northern Crane Works	107	Trabern Pump Co.	87
Can. Fairbanks-Morse Co.	34	Hamilton Motor Works, Ltd.	175	Norton, A. O.	104	U	
Can. Desimon-Stephan Mfg. Co.	97	Pama & Co., M. A.	69	Norton Co.	22	Union Tool Chest Works	105
Can. Drawn Steel	105	Hawkeley Bros.	69	Norton Grinding Co.	75	United States Electrical Tool Co.	37
Can. Economic Lubricant Co.	8	Hendey Machine Co.	24	Nova Scotia Steel & Coal Co.	72	V	
Can. Inspection & Testing Laboratory	92	Hedden, John T.	5	O		Vanadium Alloys Steel	12
Can. Metal Products, Ltd.	78	Hepoff Mach. Co.	105	Oven Equipment & Mfg. Co.	17	Vapor Tool Co.	98
Can. Steel Foundries, Ltd.	7	Holz, Herman A.	121	P		Victoria Foundry Co.	16
Can. S. K. F. Co.	5	Homer & Wilson	79	Parmenter & Bulloch Co.	126	Vulcan Crucible Steel Co.	97
Can. Welding Works	107	Hoyt Metal Co.	76	Perrin, Wm. R.	80	W	
Carbonium Co.	24	Hungerford Brass & Copper Co.	92	Peerless Machine Co.	97	Walton Co.	96
Carle Johnston Mach. Co.	8	Hull-Butt-Rogers Machinery Co.	114	Petrie, of Montreal, Ltd., H. W.	71	Walcott Lath Co.	18
Chapman Double Ball Bearing Co.	87	Hyl-Engineering Works	71	Port Hope File Mfg. Co., Ltd.	28	Wells Bros. of Canada	32
Cincinnati Iron & Steel Co.	22	I		Positive Clutch & Pulley Works	103	West Tire Slatting	89
Cincinnati Pulley Machy. Co.	115	Independent Pneumatic Tool Co.	68	Pringle, R. E. T., Ltd.	98	Whiting Foundry Equipment Co.	87
Cleveland Twist Drill Co.	111	Iron Works, The	68	Puro Sanitary Drink'g Fountain Co.	68	Whitney Mfg. Co.	24
Commercial Acetylene Welding Co.	82	J		R		Wilkes Bros.	17
Cook, Asa S.	104	Jacobs Mfg. Co.	103	Racine Tool & Machine Co.	95	Williams, A. R., Mach. Co.	63
Cooper Co., C. & G.	74	Jacobs Mfg. Co.	75	Reed-Prentice Co.	31	Williams, J. H., & Co.	92
Corbet Foundry & Mach Co.	22	Juekes Mach. Co., The	9	Z		Williams Tool Co.	95
Cullen Machy. Co., C. W.	72	Jesse City Mach. Co.	106	Zenith Coal & Steel Products Co.	105	Willson & Co., Inc., T. A.	106
Curtis & Curtis Co.	97	Jobson, Geo. E.	49			Wilmarth & Morman Co.	194
						Windsor Mach. & Tool Works	17
						Winnipeg Gear & Engineering Co.	77



Equipment, Methods and Devices for Machining 6 in. Shell

Staff Article

Shell production still holds the premier place in the activities of our metal-working industries, although, in the case of the 8-inch and 9.2-inch sizes of high explosive, a marked falling off in the demand and consequent receipt of contract renewals has for several weeks been in evidence. Machining 6-inch shell is believed to have taxed executive skill and capacity to a greater extent than has any other of the variety projectile manufactured by us, in consequence, successful achievement as exemplified here is all the more meritorious.

PRODUCTION of shell on a vast manufacturing basis has become so well established throughout the Dominion that it would seem impossible to describe the machining of any type of shell that has not already received notable mention in these pages. However, the varied enterprise that large numbers of our mechanical men have

had occasion to demonstrate in a practical way to procure rapid and successful manufactures of the varied size and type shell called for, has developed much inventive genius and latent individual resourcefulness, so much so that the methods adopted in different shops for the achievement of the same object vary in large degree, with the excep-

tion perhaps of some of the more common machining operations.

In relating the practice that has been adopted in the plant from which the accompanying data were secured, it is not the intention to describe in detail the complete sequence of operations, but rather to dwell on those that are in a measure, local, so to speak. Past ex-

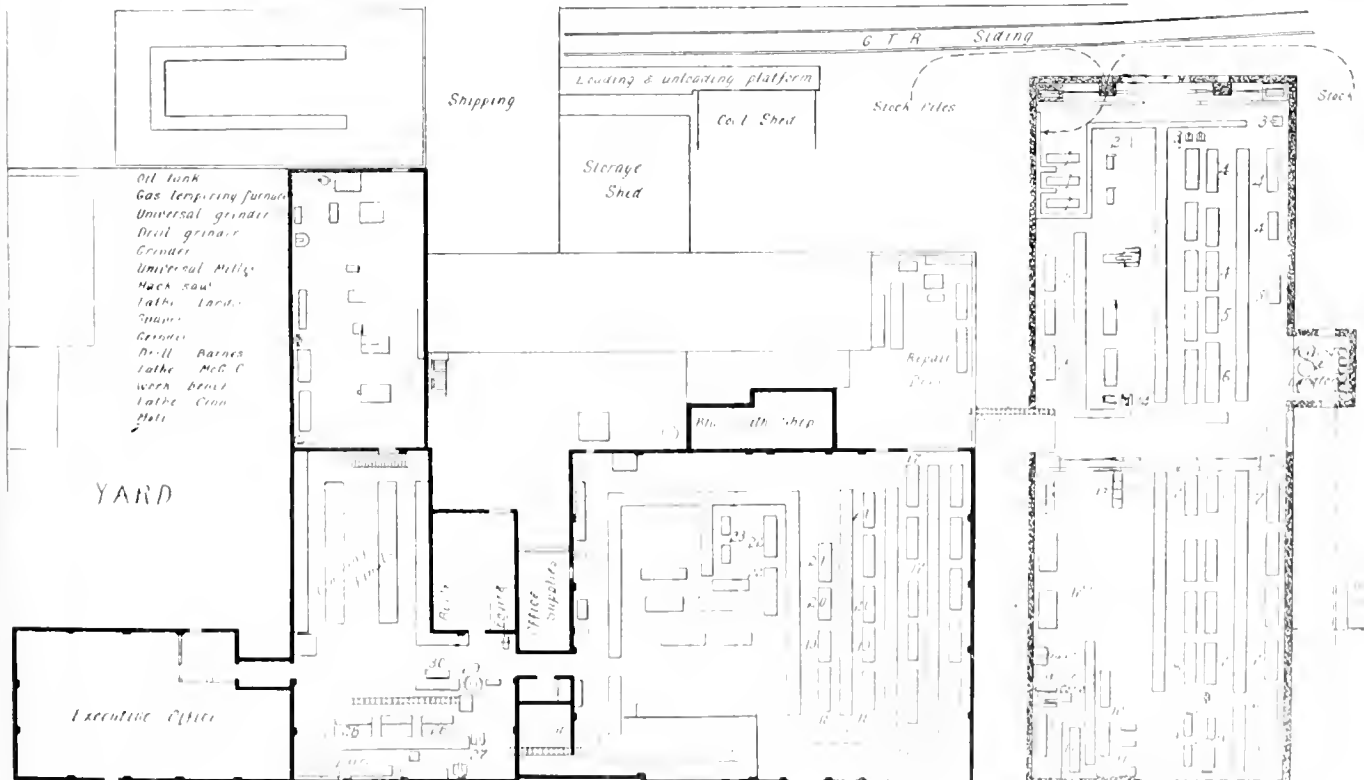

LAYOUT OF 6-INCH HIGH EXPLOSIVE SHELL MACHINING PLANT.

perience has clearly demonstrated that one of the first things to consider when going into the manufacture of any type of shell, is the layout of the necessary equipment in as convenient a manner as possible, so that the minimum amount of handling of material will enable the progress of the shells to be entirely free from

amental details when placing the machinery, if satisfactory progress is to be maintained. Where an old plant must be utilized for the placing of the additional equipment that is involved by the many machining operations on shell bodies, it is often a difficult problem to plan a suitable layout, particularly where the machines must be crowded to meet the desired amount of output; but in cases where new additions are necessary it is very desirable

space to secure sufficient room for additional equipment. After several trial layouts, the one here illustrated was finally adopted, requiring the addition as shown to the right of the ground plan of the machine positions. This building is of concrete and brick construction, 160 feet long and 60 feet wide, having saw-tooth roof and being hot air heated. The floor space amounting to about 9025 square feet. With a view of providing the best possible lighting, the



GERARD CUTTING-OFF MACHINES.



GENERAL VIEW OF SECTION OF SHELL SHOP.

to construct the plant with the progressive movement as the basis of output; in other words, to first plot a machine tool layout (with plenty of room for possible expansion on doubtful operations), and then build the shop around the layout. In the case of the plant here described, an output of approximately 400 six inch shell per day was determined, to accomplish which it was necessary to increase the floor

roof was constructed so that the light enters from the north, thus eliminating the glare of the sun during the greater portion of the day. The plant is very favorably located as regards the receiving of raw materials and the shipping of the finished products, adjoining as it does the main line of the G.T.R., and having a convenient siding along one end of the shop, where a platform 60 feet long offers desirable facilities for the loading and unloading of billets and shells.

any "backing up," as they are transferred from one operation to another. While ideal conditions in this respect are not always possible, it is very essential that careful attention be given to these fund-

it was necessary to increase the floor

Rough Facing Bottom of Bore

As the billets are received from the cars, they are placed in stock piles adjacent to the rear of the new building, and when required for use are transferred to the shop through suitable openings in the walls and thence to the first operation of rough facing the bottom of the bore. This detail was deemed advisable so that a reliable base could be secured from which to gauge the subsequent operations. As no particular accuracy is required at this stage, the machining is done with a floating cutter that will accommodate itself to the irregularities of the bore and yet produce a clean smooth base. The maximum cutting speed is 40 feet per minute and a production of 12 per hour is maintained on each machine, the feed being obtained from a cam. The tools used for this operation are shown by (1) on the operation chart. It might be stated here that for all boring operations, a standard machine steel boring bar has been provided, and with the exception of the turret shank, they are identical in every particular. The details

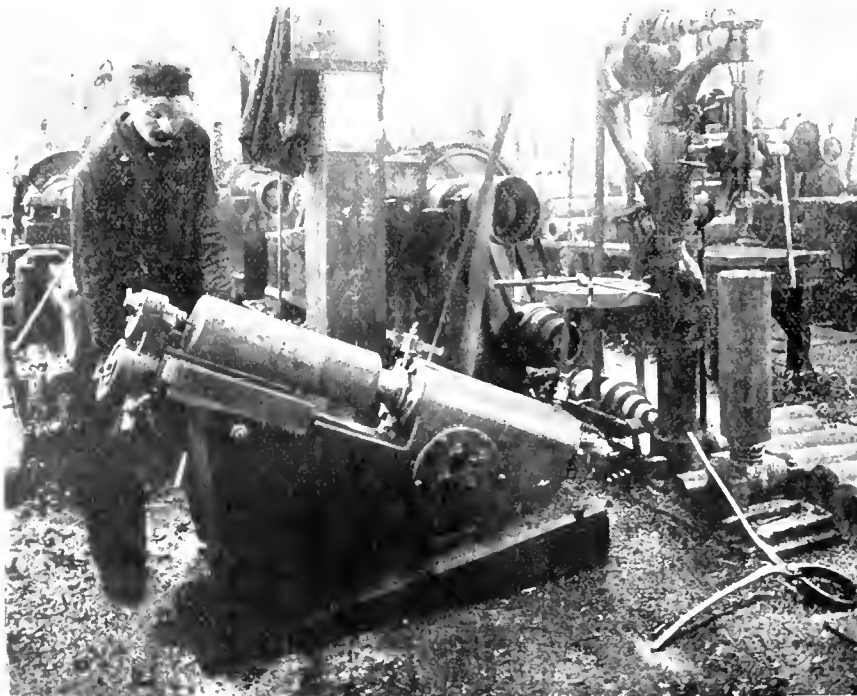

VICTORIA FOUNDRY CO. MACHINE FOR CENTERING BASE OF SHELLS.

of this bar are shown in the upper right hand section of the operation chart, the cutter heads being held in position by means of a key passing through the end of the bar and the shank of the tool holder.

Cutting Off Open End

Cutting off the open end is performed on five Gerard cutting off machines. The latter are provided with a revolving cutter head while the shells are held stationary in a chuck attached to the saddle of the machine. For centering the base end, an interesting machine shown herewith is used: this tool being made by the Victoria Foundry Co., of Ottawa, and being specially designed for the purpose. Integral with the extra heavy base is the main bearing that carries the spindle and also the work arbor, the latter being an extension of the former. The position of the spindle is approximately 30 degrees off the horizontal, and provision is made in the mandrel to grip the shell bore central with the machine arbor and retain it in a rigid position as it is revolved. On the bed of the machine below the arbor, ways are provided that support the carriage which can be moved laterally and parallel to the axis of the spindle by means of a rack and pinion. On the outer end of the carriage, a swivel arm is fitted which can be swung clear when

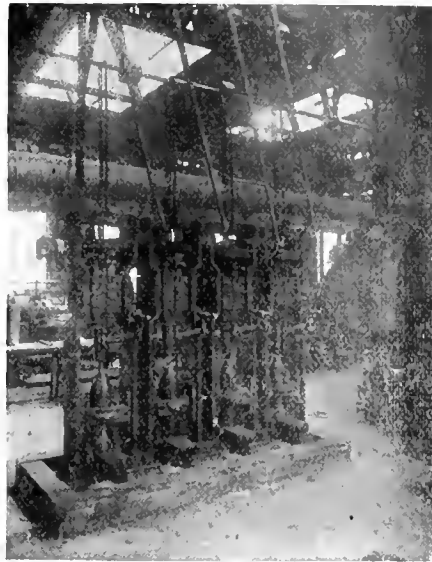

ROUGH BORING SHELL NOSE ON FOUR-SPINDLE DRILL.

the shell is being placed on or being taken off the arbor. When in a working position, the center of the drill holder is in the axial line of the machine spindle, and likewise the shell bore. The feed of the drill is obtained by a hand wheel located at the opposite end of

the pinion shaft. The angular position of the supporting arbor provides a convenient method of holding the shell, the weight of the shell acting as a semi-automatic means of operating the expanding arbor. The production from one of these machine averages about 120 in ten hours.

Rough Turning

Rough turning is accomplished in a very similar manner to that of other shops, the details of the driving arbor being shown at (2) on the operation chart; each machine has an output of six shells per hour. For roughing out the bore, the special cutter head shown in section (5) of the operation chart is employed. Stellite, $\frac{5}{8}$ inch square is used for cutters. The diameter of the large section of the head is 3 7-16 inches, with a tool overhang of about $\frac{3}{8}$ of an inch. At a cutting speed of 60 feet per minute the production from each machine is about 7 per hour. Roughing out the base profile is performed in a separate operation; the cutter head used being shown in section (6) of the operation chart.

An arrangement of the Dawson boring machine used for boring and roughing the inside base profile is shown in drawing on page 502. The driving pulleys are located on the shaft A.

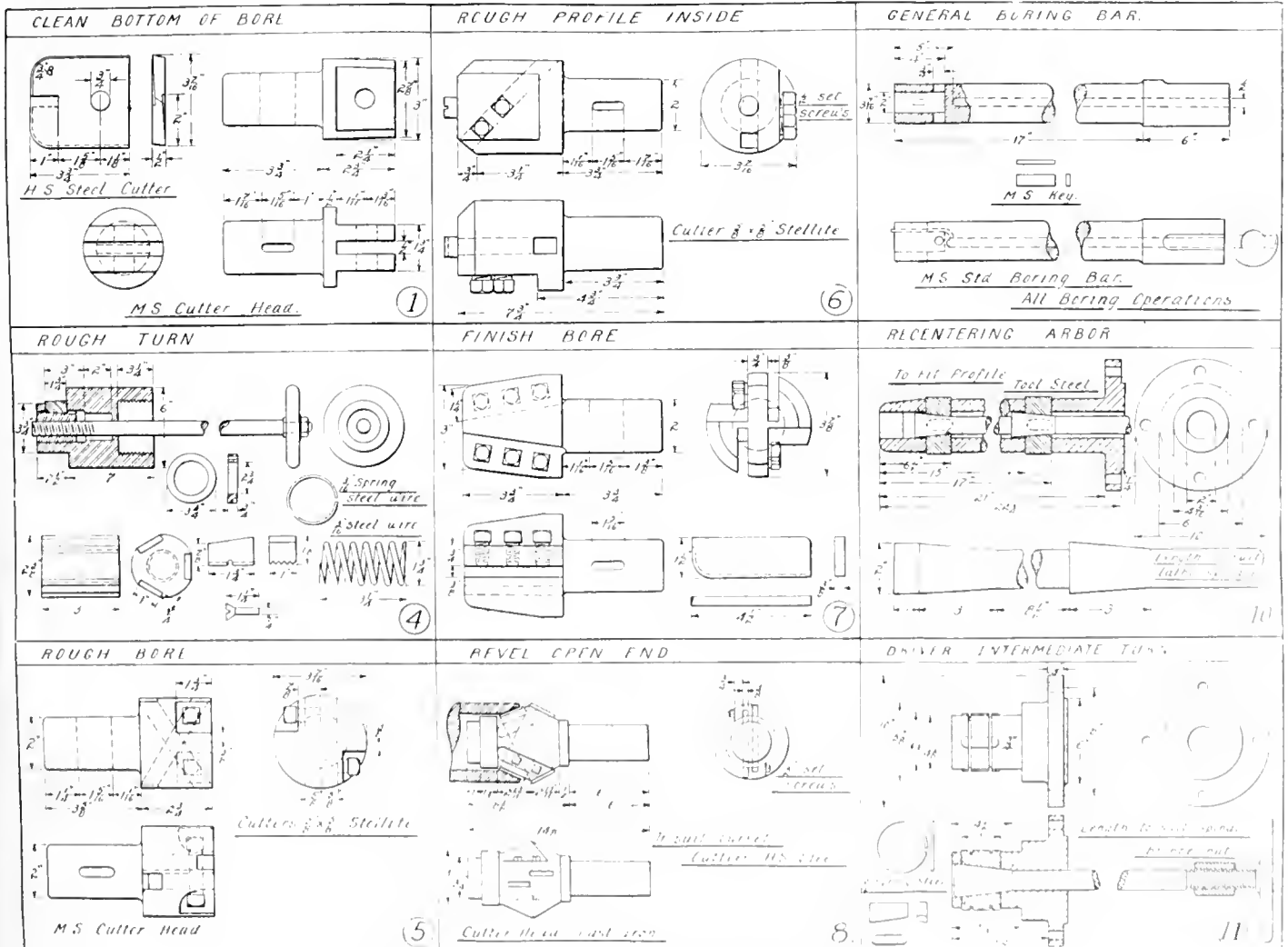

TOOL CHART, 6-INCH HIGH EXPLOSIVE SHELL MACHINING

OPERATION	MACHINE	No	TOOLS	Cut Spd	Feed	10 Min Output
1 Face bottom of bore	Reliance Mch Co	2	Floating Cutter	40	Cam	120
2 Cut off open end	Gerard	5	1/2" Red Cut	40	1/64	60
3 Center base end	Victoria Foundry	2	Comb Center			120
4 Rough Turn	Mil Edy & Mch - Hepburn	3-4	H S Steel	45	1/8	60
5 Rough bore	Corsell-Price - Columbus	1-1-1	Stellite	60	1/8	70
6 Rough profile	Reliance Mch Co	2	Stellite	60	1/8	130
7 Rough & finish bore	Hepburn Turret	10	H S Flat Cutters	60	1/8	35
8 Bevel open end	Gerard	2	H S Flat Cutters	40	Hand	120
9 Cut off base	Gerard - Victoria	4-1	H S Steel	45	1/8	50
10 Reenter on arbor	W Simplot	2	Expanding arbor	100		150
11 Rough Turn	Hepburn - Simplot	1-2		120	1/8	25
12 Closing nose	Hazel 250" Hammer	1	Sawdges			300
13 Rough bore nose	Four Spindle Drill	1	1/2" Drill	65	1/8	80 per spindle
14 Rough face nose	Drill Press	3	Facing Cutter	40	1/32	100
15 Bore & dr nose	Buwaen Lathes	4	Kelly Reamers	40	1/32	70
16 (Inside profile)	Jones & Lamson	2	Special	40	50 - formea tool	
17 Finish turn & profile	Daleport-Simplex - CMC	2-6-2	Stevens Link	100	1/8	40
18 Face base to weight	Gerard Turrets	2	Vic Fly Attachment	80	1/8	130
19 Wade & groove	Bauden	2	Vic Fly Attachment	40	Hand	120
20 Rough base recess	Gerard - Dawson	1-1	Special	60	Air	150
21 Finish base recess	Gerard	2	Floating Reamer	40	Hand	150
22 Bevel just s & recess	Jones & Lamson	2	Special	60	Hand	120
23 Mill just thread	Holten Morgan	2	Thread Mills		1/2	200
24 Rivet base plate	Rechester Hammer	2				150
25 Finish base end	Gerard	3			1/8	180
26 Press on hand	Guide McCulloch	1				200
27 Turn band	Reliance	1			Hand	200

MACHINE OPERATION CHART.

which is supported at right angles, and below the main spindle, in the two brackets B, one on either side of the machine; the outer end of the driving shaft being supported in the tail bracket C, which in turn is secured to the bracket C' bolted to the casting C^U, extending out from the bed of the machine. A worm on the shaft A engages with the large worm gear D which is secured to the main spindle E, the latter revolving in special bronze bushings F in both the front and rear bearings. Fitted to the front of the spindle is the spring chuck G that grips the base end of the shell, the forward end running in a suitable steady head. By means of a chain drive on the sprockets H and I, the feed shaft operates the mechanism contained in the saddle of the lathe.

By pushing down on the handle L, the worm box is lifted, bringing the worm in mesh with the worm gear which is located on the opposite end of the hand wheel shaft, the pinion operating the carriage being secured to the middle of the shaft so that a central drive is ob-

tained, thus eliminating any side pull upon the saddle, and insuring a uniform

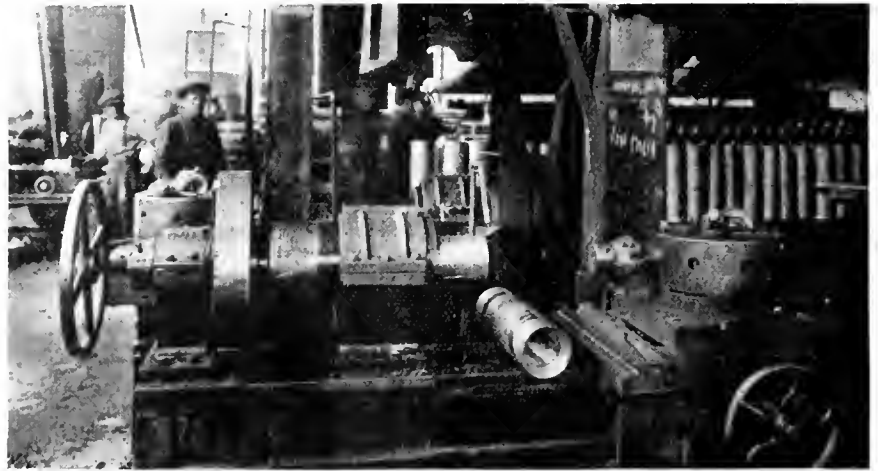

BEVELLING OPEN END WITH SPECIAL TOOL-HOLDER, GERARD TURRET.

thrust upon the cutting tools. The handle L is in a convenient position to

the operator while the worm box K is located at the rear of the lathe, the connection being made by means of a cross lever pivoted in the center of the lathe bed. When the worm and gear are in mesh, the handle L is locked by the dog N fitted in the end of the swing piece O. The feed can be disengaged at any desired point by adjusting the position of the collar Q on the rod P, so that it will trip the piece O and allow the worm to fall from a working position.

The carriage R travels on the shafts S, one of these being placed on either side of the machine and being supported at each end by the brackets T T. The turret U is provided with two housings in which the boring bar V is secured by the clamps W. On the rear end of the bar the guide piece X is located, this piece controlling the movement of the forward end in its passage through the

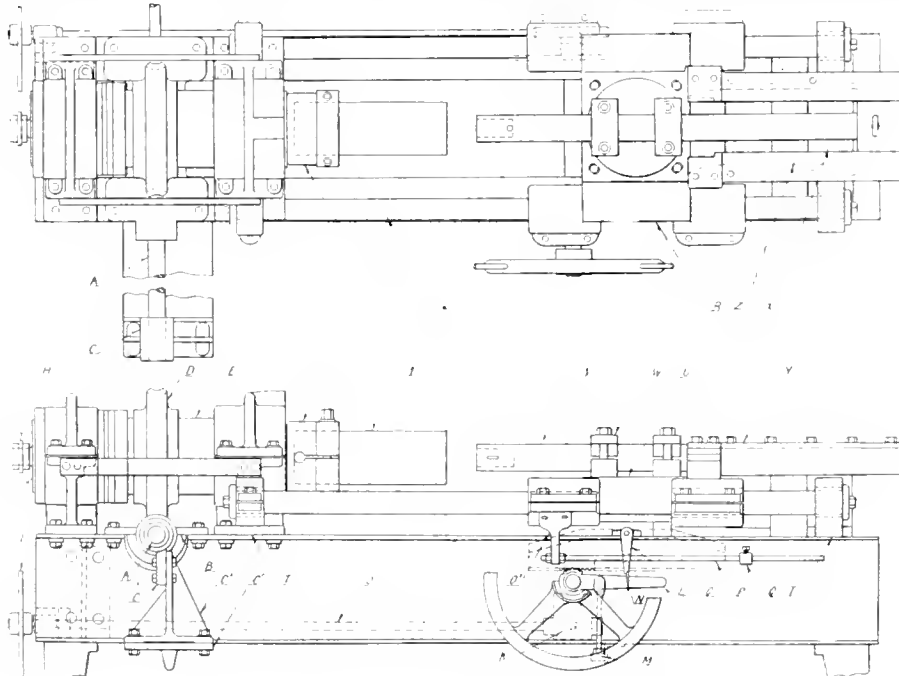

ARRANGEMENT OF DAWSON BORING MACHINE.

bore, the cam plates Z being shaped at the end adjoining the turret so that the cutting tool will cut the desired shape of base profile. Stellite tools are used on this operation, and a stop is placed in the end of the cutter head to gauge the depth of the cut when the tool is in the extreme bore of the shell.

Finishing the Bore

The tool used for finishing the bore is shown in section (7) of the operation chart. It has been the practice in this shop, as far as possible, to provide tools that would require the minimum amount of skilled labor in the maintenance of their efficiency. As shown in the sketch, the cutter head is shaped to an angle so that straight portions of steel can be used to bring the cutting edges to the desired dimensions, with the exception of the nose radius and the small portion that sizes the finished bore of the shell; these being shaped after the steel is secured in position. At this operation, the bore is finished to 4.24 inches diameter and to an overall depth from the open end of 19 1/2 inches.

Beveling Open End

A cheap yet highly effective cutter head has been designed for beveling the open end previous to closing in the nose.

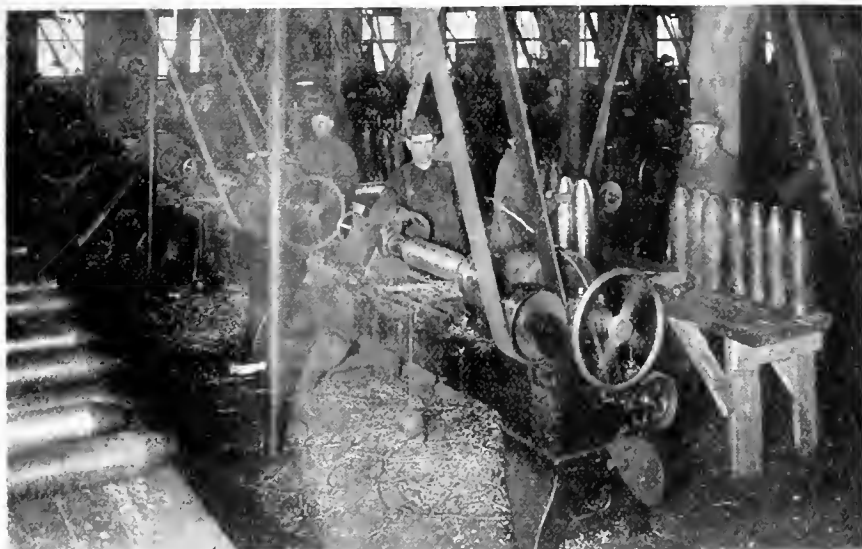

BATTERY OF FINISH TURNING LATHES.

This head is shown in section (8) of the operation chart and is made of cast iron; the holes for the cutters being rough cored, no machining being necessary on this particular portion of the head. The shank, of course, as well as the gauging collar, is turned to the desired dimensions and screw holes drilled for clamping the tools in position. The cored holes are placed in such a position that the cutting face of the tools are ground at right angles to the length of the stock so that little difficulty is experienced in maintaining their efficiency. The dimensions of this beveled portion are a large diameter of 5 9-16 inches tapering to the bore of the shell, and having a depth parallel with the axis of 1 1/2 inches. After the base has been faced off and the end recentered, the shells are given another rough turn at a cutting speed of 120 feet per minute, with a feed of 1/8 inch, the depth of cut being about 1-32 inch.

Interior Grinding

Before passing to the nosing operation, the shell are all carefully inspected for interior finish, as it is important

that the surface of the bore should be perfectly smooth and free from ridges that might eventually prove detrimental

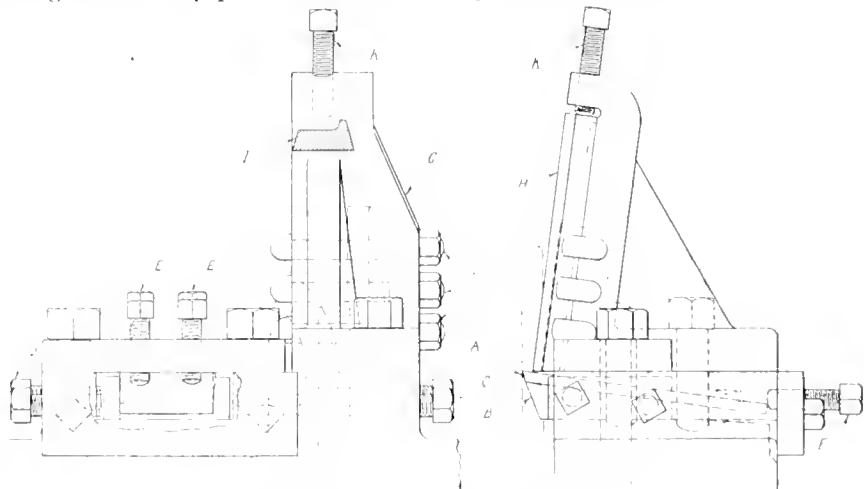

HOGGING OUT AND FACING BASE.

under firing conditions. Those shells that have developed any roughness through improper machining and are

within the specified limits of bore dimensions, are subjected to a grinding process to remove the greater portion of this roughness. A simple fixture has been developed for this purpose and is shown herewith; it consists of a rapidly revolved spindle to which are fixed spring arms carrying small pieces of grinding material to bear on the surface of the bore while the shell is held in a suitable carriage as shown at A is shaped to receive the arms B which are secured to the shaft close up to the headstock. Through the outer end of the extension and also the spring arms, is the small bolt C that allows the arms to move outwards but prevents them from flying out too far when the centrifugal force is set up by the rapidly revolving parts. A fork is provided on the outer end of the arms in which the carborundum blocks are clamped as shown. The carriage that supports the shell is planed out so that, when the shell is in position, the center will be in a line with the axis of the spindle when the carriage is riding upon the supporting rails F. When the shell is placed in position, the clamp is swung

over, the end G being shaped so that the handle H when swung upwards will force the clamp down upon the top of the shell. The pressure resulting from the centrifugal force is sufficient to take a good bite upon the surface of the metal.

Nosing-in Process

The nosing-in process, as performed on a 250-lb. Nazel hammer is so satisfactory that a large number of the shells do not require to be further machined on the profile inside the nose. One of these hammers can nose about 300 six inch shells in 10 hours. When the shells come from the nosing hammer, the opening in the end is only about 3/4 of an inch in diameter. To enlarge this opening, the shells are placed in fixtures secured to a four spindle drill where the hole is rough drilled with an 1 1/4 inch drill, running 65 revolutions per minute, at a feed of 1-16 per revolution, each spindle having an average capacity of about eight shells per hour, one man operating the four spindles. The nose



WAVING AND GROOVING ON BAWDEN LATHE EQUIPPED WITH VICTORIA FOUNDRY CO. ATTACHMENT.

is then faced off in several drill presses, a special facing cutter being used for this purpose. The overall length at this stage is $21\frac{1}{4}$ inches.

Exterior Finishing

Following the boring and counterboring of the nose, and the machining of the inside profile (if this latter is found necessary), the shells are transported to another department by means of a short conveyor. They now enter upon the second stage of the machining, that of finishing the exterior surfaces. Ten lathes are employed on finishing the body and nose profile, this operation being accomplished in much the same manner as that in vogue in other shops. At a cutting speed of 100 feet per minute and a feed of 1-16 inch per rev., each machine has an output of between four and five per hour; Stevens link attachments are used to machine the nose profile. When the outside has been finished, the base is again faced to bring the shell to the desired weight, care being exercised to keep the length and thickness of the base within the specified limits. The high and low limit at this stage is 85 lbs. 5.7 oz., and 84 lbs. 1.3 oz. respectively, with a mean of 84 lbs. 11.5 oz.

Waving Operation

The tooling for the waving operation is similar to all other methods, but the principle of securing the lateral movement is slightly varied. This is obtained by means of a fixture attached to the back of the saddle, the driving shaft being connected to the gearing at the back of the lathe, and operating through a gear box, the right angle shaft having a small throw crank turned on the end; from this crank a link converts the revolving motion of the fixture into a reciprocating movement of the tool slide. This attachment was made by the Victoria Foundry Co., each machine having an output of about 12 shells per hour.

Roughing Out Base Recess

The machines for roughing out the

base recess have a capacity of 15 per hour with a maximum cutting speed of 60 feet per minute. The accompanying photo shows a special Gerard machine on this operation. These lathes are all fitted with special turrets, and the front bearing is of extra heavy design to provide rigid support for the spindle in which is contained the collet chuck for

the screws E and adjusted to depth of cut by the tail screw F. An upright casting shaped to give the proper rake to the facing tool H is secured to the back of the same fixture. A section of the Stellite tool is shown at I, this tool being held in position by the three hook bolts J and adjusted to cutting position by the screw K. The base recess is

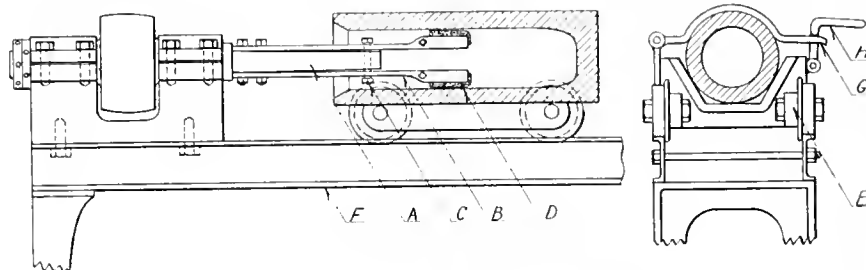

FIXTURE FOR GRINDING SHELL INTERIORS.

holding the shell. An 8-inch double belt drives the back shaft, the pinion on which meshes with the large gear which is cast integral with the spindle. The chuck is operated by the large hand wheel at the rear of the spindle. A feature on the lathe here shown is the method of feeding the tools into the work. Mounted on channel irons extending out from the bed of the lathe—is an eight inch cylinder, the piston of which is operated by compressed air, the pressure acting to force the cutters into the work being approximately 1 ton. This cylinder being located in the center of the lathe, the thrust is central, thus maintaining more satisfactory work and retaining turret alignment for a longer period. A sketch of the tool set up is also shown; the tool A made of $\frac{1}{4}$ inch by $2\frac{1}{4}$ inch high speed steel is used for hogging out the base recess, and is held in the tool block B shaped at the proper angle to give the desired rake to the tool. Lateral adjustment is obtained by the screws C and D, those at the right pushing on distance rods $\frac{3}{8}$ inch in diameter. The tool is held firmly by

afterwards finished to the exact dimensions with a cutter and floating reamer.

Nose Beveling, Recessing and Threading

Before the threads are cut in the nose, the face is beveled and the recess cut in. Two Holden-Morgan milling machines are installed for this operation, each having a capacity of 200 shells every ten hours. Conveyors are used to transfer the shells to and from the base plate riveting operation, which is accomplished in two Rochester high-speed hammers. After facing the base end, the copper bands are pressed on in a Goldie & McCulloch band press, being afterwards machined in lathes fitted with special turning fixtures. The cleaning of the shells, which takes place just after milling the fuse thread, is accomplished by forcing a jet of live steam into the interior and afterwards removing the moisture with a strong blast of compressed air, the heat generated by the action of the steam being sufficient to thoroughly dry the surface of the walls within one minute from the time the shell is removed from position.

A factor in production methods in this plant responsible for much of the successful operation has been the rigid check that has always been enforced in the preliminary shop inspections. These are as rigid as the Government inspection and must be held close enough so that corrections by the Government inspectors will not go above 5 per cent. The final weight of the shell should be 84 lbs. 2 oz. 5 drs., with an allowable variation either way of 10 oz. 2 drs.



Wondered What He'd Say.—The country clergyman was nailing a refractory creeper to a piece of trelliswork near his front gate when he noticed that a small boy stopped and watched him with great attention.

"Well, my young friend," he said, pleased to see the interest he excited, "are you looking out for a hint or two on gardening?"

"No," said the youth, "I be waiting to see what a parson do say when he hammers his thumb."

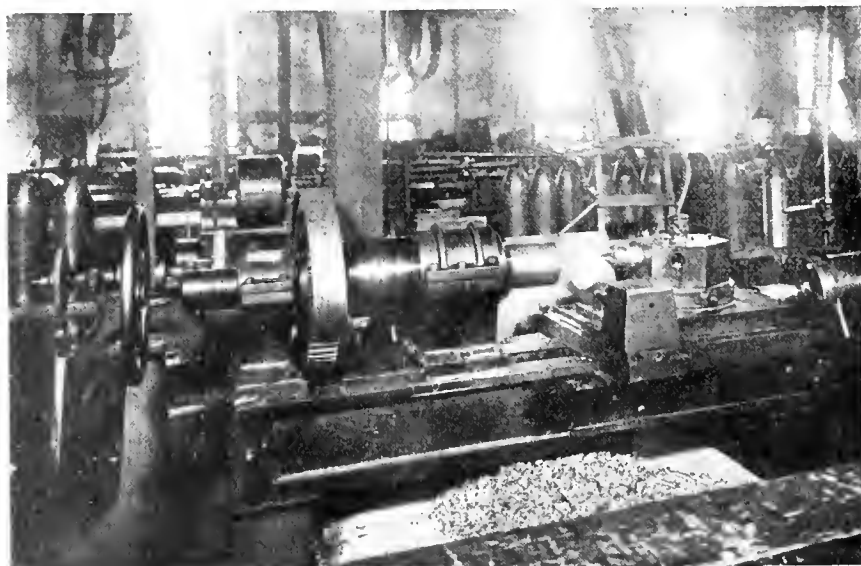

ROUGHING OUT BASE RECESS ON GERARD LATHE WITH PNEUMATIC FEED.

PRODUCTION METHODS AND DEVICES

A Department for the Interchange and Distribution of Shop and Office Data and Ideas Evolved from Actual Practical Application and Experience

OIL BURNER FOR SHELL FURNACES

By G. Barrett.

IN the process of nosing 4.5 and 6-inch shell, difficulty is often experienced in maintaining proper combustion of the elements when the shells are being heated. This is sometimes owing to insufficient mixing of the oil and air, as

the most "convenient way" of handling tools or work. The saving in time may not necessarily be appreciable. In certain lines of work, particularly of a class that is repeatedly handled over and over again, one notices how little attempt is ever made to render the operations less irksome, or in giving them the proper consideration and study so that they may

ways "still better ways" in doing a thing, any undertaking in the direction indicated will reveal what these "better ways" are. To demonstrate a simple application of the term "time saving" in the sense already described, an example is given on the well-known operation of changing or putting gears on a lathe. Illustrations are shown for the purpose that they may be examined so one may see where a few little inexpensive conveniences have been adopted.

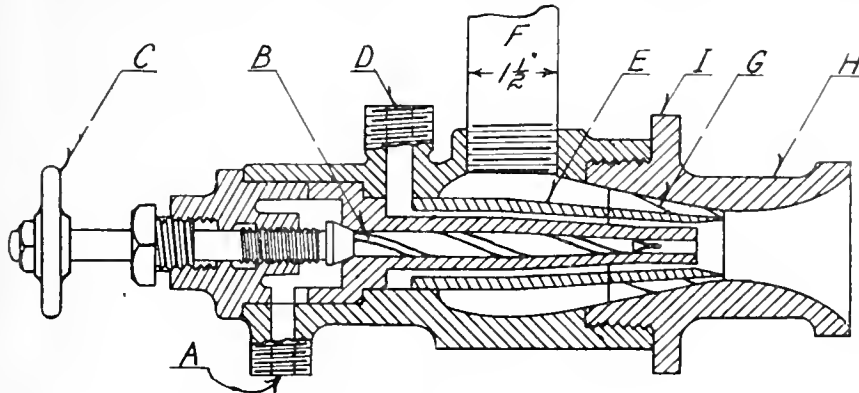

SECTION OF OIL BURNER FOR BOX FURNACES.

they are forced into the fire chamber. To eliminate this objectionable feature, the burner shown in the accompanying sketch was adopted with very satisfactory results. This type of burner is easily applicable to any make of furnace. The oil enters the burner at A, passing through the central chamber where it is given a whirling motion by means of the twisted spindle extension B. This portion is made from round stock and milled flat and then twisted; the amount of oil is controlled by the hand wheel C. The compressed air at a pressure between 40 and 60 pounds enters the opening D through the hollow cone E and around the central tube. The wind from the blower or fan enters the burner through the large pipe F, this pipe being provided with a suitable valve to regulate the quantity of air required. To further assist the mixing of the elements, a spiral cone C is fitted on the inside of the nozzle H. The spread of the flame is obtained by adjusting the position of the nozzle; this being accomplished from the collar I, it having several slots cut around the outer edge. This burner is very efficient, using about 8 gallons of oil per hour.

be more conveniently carried out. If a workman is constantly obliged to handle a screw-driver or a monkey-wrench to unloosen a screw or to unfasten a nut, it is reasonable to believe that, where the application of these is now a practice, a thumb-screw or a thumb-nut would serve the same purpose besides being more convenient and saving handling extra tools.

The key on the "stud" on all lathes is usually made flush with the end on which the gear fits, so that when putting on a gear one must locate the spline exactly before it will engage and slip over the key. If the key is made shorter, the gear can be placed directly on the stud, then turned and a little pressure forces the spline instantly over the key. The key is rounded on the end, as is also the edge of the spline and the hole in the gear hub. The nut which is put on after the gear is fitted, is counterbored out a trifle so that it can be placed over the thread and quickly screwed on. The wrench used in tightening the nut has not been overlooked in these series of conveniences, the edges in the opening being beveled off which allows the wrench to engage with apparent ease onto the nut. Generally speaking most operations that have to be repeated over and over again in the course of one's work can be similarly improved upon.



TAPER TURNING ATTACHMENT TO BORING MILL

By E. T. S.

THE diagram shows a simple arrangement for producing duplicate taper faces on a boring mill. It consists of a master

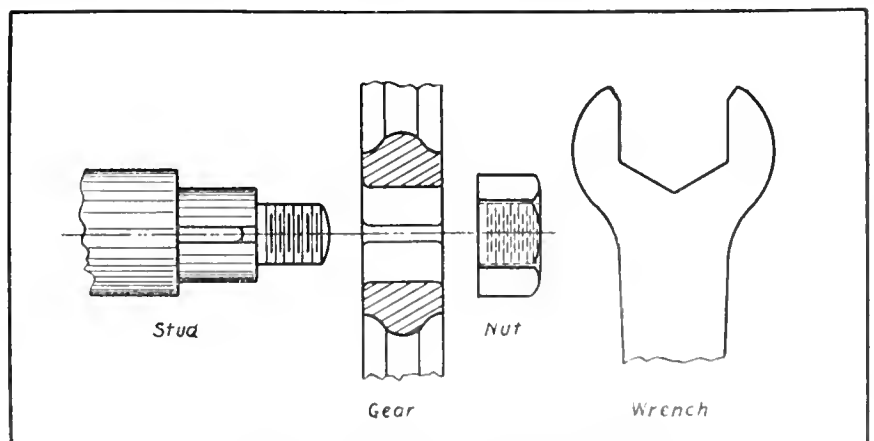

TIME SAVING IN MACHINE SHOP PRACTICE.

TIME-SAVING IN MACHINE SHOP PRACTICE

by J. E. C.

THERE is another application of the term "time-saving" other than that which has to do with "increased production," "lowering labor costs," "economical processes," etc., to which consideration is suggested. Its particular object may be said to consist in finding out "the better way," "the easier way," or

Only in this way can there be any noticeable progress made. It is sometimes said, if a thing works well enough, it is good enough, but as there are al-

guide which is adjusted to the taper required. A pin in the tool bar fits into the slot in the master guide, and the horizontal feed of the cross rail is set in motion.

The vertical feed is released so that the position of the tool follows the shape of the master guide. It can readily be seen that any special form of surface can be

STEEL HANDS FOR MACHINISTS.
UNTIL recently, the loss of both hands has been looked upon as a calamity little short of total disablement, which, if

a man who did not retain one natural hand. Accordingly, with the aid of his brother and a blacksmith acquaintance, Mr. Gawley had a pair of hands made

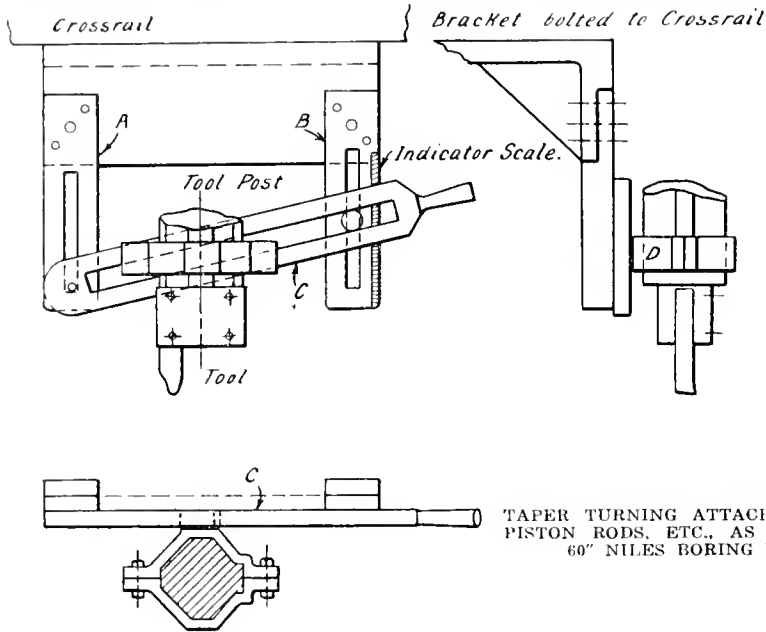

TAPER TURNING ATTACHMENT FOR PISTON RODS, ETC., AS FITTED TO 60" NILES BORING MILL.

made by providing the proper shaped master guide.

Slotted brackets A and B are bolted to angle brackets which is attached to under side of cross rail. The guide C is adjustable to any position or angle, the angle being shown by the indicator scale. Collar D is fitted to tool post and has a guide block that works in the guide C. In operation the cross feed is set, and the vertical feed left loose.

alleviated at all by the use of artificial limbs, was still sufficient of a handicap to prevent the victim from earning a livelihood at any light employment, let alone performing operations of a fairly arduous nature in machine shop work.

Such, however, is not the case with the man who is shown in action in the illustrations herewith.

Andrew Gawley was formerly a resident of Meaford, Ont., and suffered the loss of both hands above the wrists many years ago through coming in contact with a circular saw. During his stay in hospital his mind naturally dwelt on the disaster and its probable effect on his future existence, with the

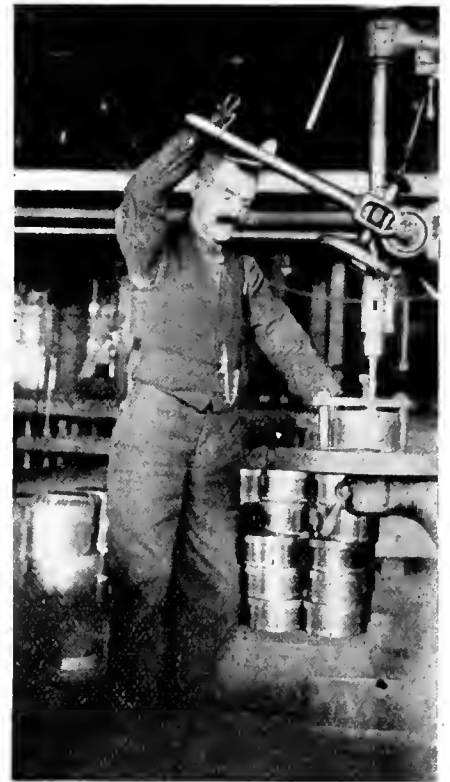

ANDREW GAWLEY DRILLING ADAPTERS IN A VERTICAL DRILLING MACHINE.

embodying his own ideas. Extended experience suggested various improvements, until to-day he can do with his steel hands almost anything that an ordinary man can do.

Performing Machinist's Work

He is now employed by the Fisher Motor Co., Orillia, Ont., and officials of the company vouch for the fact that on



A CLOSE VIEW OF MR. GAWLEY'S HAND.



LIFTING A HEAVY FORGING WITH ONE HAND WHERE GRIPPING SURFACE IS LIMITED.

result that he conceived the germ of the idea which has done so much to ameliorate his lot. On his recovery, he was persuaded to accept artificial hands of existing type, which, however meritorious in themselves, were of little use to

any work on which he has been tried, Mr. Gawley possesses efficiency equal to any man in the shop. In drilling shell adaptors, as shown, he can lift them on and off the machine with one hand, which is more than the hand of flesh and blood

can do, due to the small surface available for gripping the piece. Operating the drill press feed lever, tightening nuts with wrenches, turning handwheels, and throwing belts up and down cone pulleys, were constant features of his daily work. As tool room attendant, he has to handle tools and pieces of all shapes and keep written records of all articles in use.

Regarding his ability to perform work of a personal and domestic nature, it is stated that he can, when necessary, search for a match and light a lamp, dress himself and procure his own breakfast. His handshake can be very unpleasant on occasion, while he can handle china and similar fragile goods as tenderly as a woman.

Considerable interest is being displayed in his apparatus in view of the number of maimed soldiers now returning to civilian life. Many of these were formerly machinists, and their previous skill, combined with that adaptability which is so frequently the outcome of affliction and handicap, should enable them to use such a device as Andrew Gawley's hands, so that they may to a greater or less extent be able to resume their former employment with little if any lack of efficiency.

SCREW THREAD MEASUREMENT*

AT the beginning of the war, when British manufacturers were compelled to make parts in large quantities which should be interchangeable, several facts became evident, particularly in relation to screw threads. The following were some of the principal needs:—

- 1.—An exact definition of standards and manufacturing limits to meet the new and abnormal condition.
- 2.—A more widely diffused knowledge of the principles of gauging and gauging limits.
- 3.—Experience in the method of producing accurate gauges.
- 4.—Knowledge of the methods of accurately measuring and checking gauges.

The definitions adopted throughout the article are illustrated in Fig. 1.

While no one instrument has been devised for measuring all the elements of

The instrument consists of a microscope which can be rotated about its axis, a

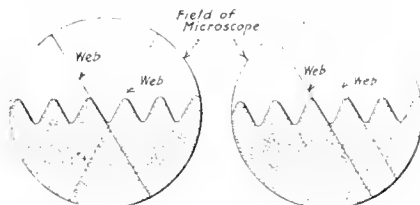

FIG. 2. METHOD OF MEASURING THREAD ANGLE BY MICROSCOPE MICROMETER.

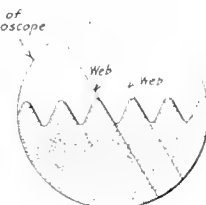

FIG. 3. METHOD OF MEASURING PITCH BY MICROSCOPE MICROMETER.

ence between the reading in the first and second positions of the web gives the

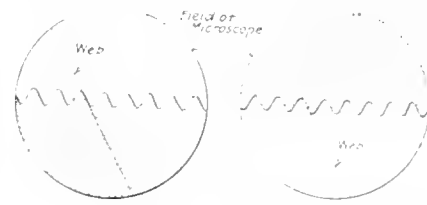

FIG. 4. METHOD OF MEASURING EFFECTIVE DIAMETER BY MICROSCOPE MICROMETER.

degree of rotation being measured by a circular scale divided into half degrees and provided with a vernier. A single thread of spider's web is stretched across the eye piece and can be rotated with the microscope. The screw under observation is mounted on centers and can be moved in two directions, first along the axis of the screw and second in a direction at right angles to the first, both movements taking place in a plane normal to the axis of the microscope. The movements are controlled and meas-

angle between the threads.

Fig. 3 shows the method of measuring the pitch. The web is brought in coinci-

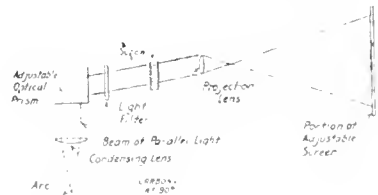

FIG. 6. PRINCIPLE OF THE OPTICAL PROJECTION APPARATUS.

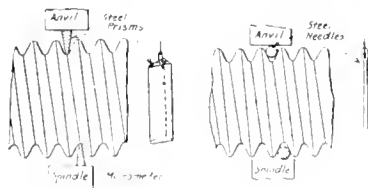

FIG. 5. METHOD OF MEASURING THE CORE DIAMETER AND EFFECTIVE DIAMETER BY MEANS OF A FLOATING MICROMETER.

ured by means of micrometer screws rading to 0.0001 in.

The screw is illuminated by a beam of approximately parallel light rays shining over the crests of the threads from the side of the screw remote from the microscope, and up the microscope tube. The direction of these rays must be in the rake plane of the thread. The accompanying illustrations show the method of using the microscope to measure the various parts of the screw. Fig. 2 illustrates the method of measuring the angle of the screw. The tube is rotated until the web coincides with

dence with the edge of the screw as for measuring the angle, and the screw is then moved in an axial direction by means of the micrometer until the web coincides with the corresponding edge of the next thread. The difference between the micrometer readings gives the pitch. Similarly, the effective diameter is measured as shown in Fig. 4. The web is brought in coincidence with a thread as before, and the screw is then moved transversely across the field of the microscope until the lower edge of the same



FIG. 7. COMARISON OF THE PROJECTED IMAGE AND TRUE SCREW THREAD OUTLINE

thread corresponds with the web. Lateral movement is given the screw as necessary by means of the other micrometer. The difference in the readings of the first micrometer gives the effective diameter. It is quite evident that the other elements of the screw can be measured by similar means.

The apparatus, as is the case with all optical instruments, is not entirely free from the personal error in observing. On the other hand, those measurements which involve similar settings of the web to produce consecutive readings are largely free from the personal error, since, being repeated, it disappears in the subtraction for the result. A careful observer with a little practice can get results true to 0.0001 in. or 1/4 deg. of angle or less.

Another method of checking core and effective diameters is by employment of a micrometer floating on balls. The screw to be measured should be of good

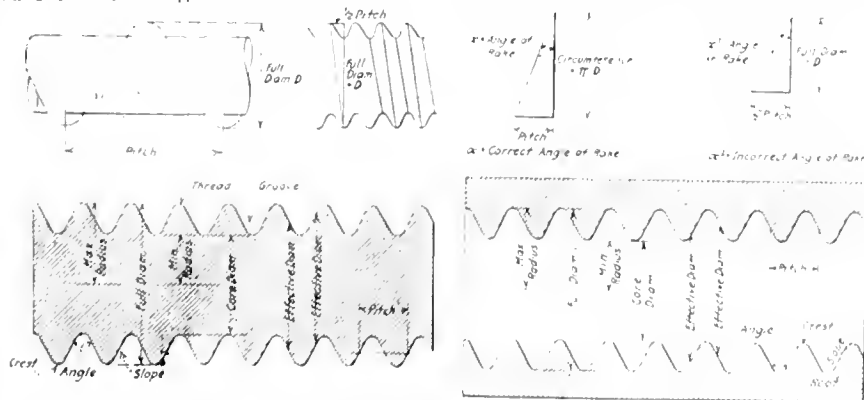

FIG. 1. SKETCHES SHOWING DEFINITIONS ADOPTED FOR VARIOUS PORTIONS OF SCREW THREADS.

a screw thread in the best possible way, the microscope micrometer has proved the most useful for all round service.

*From a paper read recently before the Liverpool Engineering Society.

the edge of the profile of the screw and the angle of the web is read from the circular scale. It is then rotated as shown until the web coincides with the edge of the adjoining thread. The differ-

thread profile with an approximately correct angle. The micrometer is free to traverse the entire length of the screw, but also maintains its position at right angles to the axis. To measure core diameter, two pieces of hardened steel in the form of triangle prisms are employed as in Fig. 5. The cross-section of the prisms is an isosceles triangle with the apex slightly rounded and the apex angle about 10 deg. less than that of the thread to be measured. The prisms are suspended in the angle of the thread, as shown, and the measurement gives the diameter of the core plus the altitude of the prisms. This altitude is determined by separate micrometer measurements, and the difference between the two gives the core diameter.

The method of determining effective diameter is also shown in Fig. 5, where cylinders, lapped circular and parallel throughout their length, are substituted for the prisms. Two of these needles of the same diameter are required for each different pitch of thread. The diameter should be such that the needles touch the slope (considered in an axial plane) of a theoretical correct thread in the middle. The micrometer reading gives the diameter over the outside of the two needles from which the effective diameter can be determined by the National Physical Laboratory formula.

$E = T + 0.96049P - 3.16568C - 0.086P^2C \div E^2$, where E is the effective diameter, T the micrometer reading less the sum of both needle diameters, C the mean diameter of needles and P the pitch.

Fig. 6 represents the principle of the projection apparatus whereby a largely magnified shadow of the thread profile is thrown on a paper screen at a known magnification. The best results are given by working with a magnification of about 50 at the screen. An outline of one or two threads of the form and pitch of the screw under examination is exactly drawn in a fine black line on the screen at the required degree of magnification and the image is projected to coincide with this line. The projection apparatus has a large application in precision work other than screw threads. Gear teeth can be examined and the outline of contour gages, cams, etc., compared with the perfect shape. Fig. 7 shows a comparison of the projected image and the true thread outline of a Whitworth thread as given by an optical projection apparatus.



SIMPLE TAPER TURNING ATTACHMENT

THE illustration shows a simple type of taper turning attachment, supplied by Alfred Herbert, Ltd., Coventry, England, for use on their No. 4 Capstan lathes, and which is intended for machining tapers up to about 1½ inches long on valve seats, plugs and similar work. The attachment, which will take care of a large variation in taper, consists of a casting bolted on to the back of the cross slide by a single bolt round which

it can swivel. The casting is bored to receive a sliding bar, at one end of which is formed a cutter head carrying the tool. The sliding bar is keyed to the casting, and a spring is provided which keeps it normally away from the headstock. On to one of the turret faces is bolted a cast iron plate with a projection arranged to push along the sliding bar when the automatic feed to the turret is engaged. The cutting tool, therefore travels in a path, the inclination of which

way. It is estimated by a well-known naval architect that if the Government should give out contracts for 200 ships, by adopting the Isherwood system 34,000 tons of steel could be saved.



SHIP PLATE MANUFACTURE IN CANADA

CANADA will not be in a position to build steel ships in quantity for at least

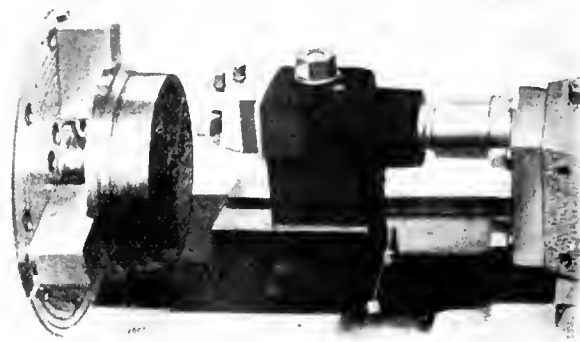

SIMPLE TAPER TURNING ATTACHMENT.

can be altered by swivelling the tool holder, whilst the cut is put on from the cross slide in the usual manner. The cutter head is cranked so that the point of the tool is on the centre of the sliding bar, and the turning moment set up by the cut is therefore small, and does not tend to put excessive friction on the sliding key.



SAVING STEEL IN SHIPBUILDING

IT is interesting in connection with the United States big shipbuilding push to learn that in mercantile shipbuilding, before she declared war, no fewer than 140 ships were ordered on the Isherwood system of construction. They represent a deadweight carrying capacity of 1,344,000, and it is estimated that the saving in steel by adopting this system is 40,000 tons.

Within the last few weeks, J. W. Isherwood, the patentee of the system, has received further requests to proceed to the States in connection with the construction of standard ships; and Japan, which is taking up the same idea, will afterwards be visited by Mr. Isherwood at the request of shipbuilders in that country. It is noteworthy that 700 ships have been built, or are under construction, on this system despite the fact it was only introduced a little over eight years ago, and it claims, we believe, 95 per cent. of the oil tank vessels now being built throughout the world. Mr. Isherwood, who is comparatively a young man, was formerly a member of the technical staff of Lloyd's.

Of considerable importance is the fact that out of a total of 672 ships which have been built on the Isherwood system, and which represent a total deadweight carrying capacity of 5,200,000 tons, the enormous amount of 150,000 tons of steel has been saved, as against what would have been required for the construction of the ships in the ordinary

two or three years, according to a statement by Mark Workman, president of the Dominion Steel Corporation, on May 10. He added that scarcity of steel was the chief cause. Mr. Workman stated that the entire output of steel from the Dominion Steel Corporation plant had been contracted for by the Munitions Board up to the middle of 1918, and the chances now were that this contract would run into 1919.

Some criticism has been directed at the officials of the corporation because of the sale of a ship plate mill some months ago to American interests. Mr. Workman, when asked regarding this, explained that the plant sold was incomplete, and that it would be impossible to make ship plates from it. He pointed out that he thought it had been purchased some seventeen years ago, had never been operated nor installed. He added that a plant properly equipped to manufacture ship plates would require an expenditure of something like \$2,500,000 and the plant sold had been purchased for \$70,000.

Going further into the prospects of steel shipbuilding in Canada, Mr. Workman said that it would be an absolute impossibility for the Steel Corporation to operate a plate mill at the present time, even if they had one on the ground, because of their inability to secure raw materials. The corporation has a rail mill lying idle because sufficient ore cannot be obtained to operate it.

"The Canadian Government Railways, the Canadian Pacific and the Grand Trunk Railways are all crying bitterly for rails, but we can do nothing to help them as shell requirements just about exhaust our product," he said. To increase the steel output further, Mr. Workman explained they would have to start at the ore output from the mines. Additional furnaces would have to be installed, as well as new coke ovens. Work is at present well advanced

on these extensions, and the corporation is spending this year something like \$5,000,000 in extensions and improvements at Sydney, but this increased output is all provided for in contracts already made with the Munitions Board.

"These extensions will require a great deal of additional labor and it will be another question whether we can secure this or not," he concluded.



USE OF GLUE IN STEEL POLISHING INDUSTRY

By H. O. Anderson.

THERE are a great many varieties of glue upon the market, but the glue used in the polishing trade is a product of the action of heat and water on nitrogenous animal tissues. This is known as animal glue and more often simply as ground glue. Glue is made from the by-products of the packing houses by boiling the animal tissues with water. From the fact that there are so many materials from which glue is made and for the fact that it is only a water solution, various lots of the same kind of glue can vary considerably. Too much care, therefore, cannot be exercised in becoming familiar with each shipment before putting it into actual use.

There are many reasons why two lots of glue from the same dealer and of the same kind might vary considerably as made, but aside from these, from the time a lot of glue has been received into the polishing room to the time it has been incorporated with the abrasive upon the polishing wheels, there are fully as many causes for variations. The use of glue in a polishing room is, therefore, a most important operation, not only from the point of economy but also for good results, and elimination of complaints on abrasive grain and on glue.

Some may think that to prepare a solution of glue, all that is required is to throw a small amount of the ground glue in with any portion of water, heat up to boiling and the glue is ready for use. Glue prepared in this manner would cause complaints against the glue dealer on the very first day of its use, or, on the other hand, the dealer of the abrasive grain would receive a complaint that the glue does not hold the abrasive to the wheel.

If glue is received in the sheet form, it is always well to pulverize it. Ground glue absorbs water and melts in the heating so much sooner that the time spent pulverizing is well paid for. The amount of water to be added to any portion of glue should be determined in the cold water soak, and this is very important, because the water absorption, the tenacity of the belly and the viscosity of the solution are very important factors in obtaining the best holding power with the least amount of glue. If the flake or sheet glue is not powdered, it requires a longer soak. The same consistency of a glue solution cannot be expected to work properly with coarse abrasive grain and with the finer sizes. The finer the abrasive grain the thinner should be the glue solution.

It is a well known fact that the weight

of ground glue varies considerably, which is a very good reason why the glue and water to be mixed should be carefully weighed. Some glue mixers fail to weigh these materials, believing that by measuring the glue and water the same consistency can be obtained which, of course, is not true. It is very important that the proportion or weight of glue and water be correct in the cold soak, because, after heating, if the solution is found too thin and more glue is added, or, if on the other hand, the solution is thick and more hot water added, very unfavorable results must be expected.

Soaking and Heating

The best time to make the cold water soak is at night, then allow to stand in a fairly cool place until morning, when it is ready for the heating process. Care must be taken that this solution does not freeze during the night soaking. The glue pot should be thoroughly cleaned out in the evening, scoured if possible, so that no dried or over-heated glue remains in it to contaminate the fresh solution. This pot should be made of copper, brass or aluminum. Under no circumstances should iron glue pots be used, as these corrode considerably, due to the action of the water, and the acid in the glue, so that in the long run the iron pot, although cheaper at first cost, will be the most expensive.

The most expensive glues can very easily be so spoiled that they would not be as satisfactory as the very cheapest glue upon the market. The greatest care in glue preparation should be during the heating operation. Never allow direct heat to come in contact with the glue pot, either as a coal fire or live steam. The proper way of heating a glue solution when glue converters are not in use is to have the glue pot surrounded by a water jacket, then either heating the water with live steam or an electric coil. If an automatic temperature controller is not used, a thermometer is recommended in the glue solution and under no circumstances should the temperature exceed 160 degs. Fah. The heating should be conducted so that the glue solution averages from 150 degs. to 160 degs. Fah., for 1½ to 2 hours, after which it can be cooled down to 130 degs. to 140 degs., and allowed to remain in this condition while being used.

If it is not necessary to continue the heating of the glue all day, a better method is to make up only such amount as is to be used immediately. Under no circumstances should more glue be made up than can be used in one day. A glue that has been allowed to stand for 10 hours, then cooled over night and reheated in the morning is absolutely of no value. If a glue is allowed to heat at the higher temperature, that is from 160 degs. to 170 degs. Fah., the value of this glue is reduced about one-third to one-half cent per pound per hour. Therefore, if conditions are such that the glue must be kept warm during the entire day it should not be at the upper temperatures. Then, too, glue is one form of

gelatine and gelatine is the medium in which germs are multiplied very rapidly. Deterioration of glue for this reason will result from prolonged heating. Where the glue dissolvers are at hand it is always recommended that these be used so that fresh solutions of glues can be quickly made up.

Another factor which enters into the preparation of glue in open glue pots is the evaporation of water. If a great deal of the water has evaporated so that the glue solution has become thicker, after several hours of heating, it is a very simple matter and a custom in some polishing rooms to add water. This is detrimental to the entire solution and it is also very unsatisfactory to use the thickened solution. Therefore all glue pots should be covered.

After the glue has been applied to the polishing wheels, which should have been heated before the application, the coating of abrasive, which has also been heated, is to be applied. If a warm solution of glue is applied to a cold polishing wheel, the chilling effect of this wheel will cause the glue to partially set or harden and thereby not hold the abrasive. If, on the other hand, the abrasive is in the cold state, this will also have a chilling effect upon the glue, and before a proper combination between the two is effected, the glue is so partly hardened that the abrasive will very easily fall off in the polishing operation.

After the wheels have received the applications of glue and abrasive, they should be dried for at least ten hours before using. This drying must not necessarily be conducted in a very hot room but, if fairly warm, they can be allowed to lay around in the polishing room. The temperature and humidity of a polishing room will change the action of the polishing wheels considerably, therefore the condition of the atmosphere in the polishing room should be kept as constant as possible so that like polishing conditions can always be expected.

The most important things in a polishing room are cleanliness of the glue pot, accurate weight of glue and water in a mixture and exceedingly careful consideration in the heating of the glue solution.

Do not expect to get good results from a glue which has been mixed in any proportion with water heated up rapidly to very high temperature, or by using a glue which was used a day or two before.

Do not expect to use glues that have been heated with water less than one to two hours unless glue converters and dissolvers are in use.—Grits and Grinds.



Comparative Mechanisms—

The Master—You look worried. What's the matter?

The Housekeeper—The nurse has just left, and there is nobody to wash the baby.

Master—Have the chauffeur do it. There isn't as much mechanism about a baby as there is about a car anyway.

EDITORIAL CORRESPONDENCE

Embracing the Further Discussion of Previously Published Articles, Inquiries for General Information, Observations and Suggestions—Your Co-operation is Invited

NOTES ON NON-FERROUS METALS FOR ORDNANCE WORK

By G. C. R.

MUCH has been said about the machines, presses, tools and methods used for producing cartridge cases and copper bands for shells, but little has been said about the metallurgical methods when the trouble experienced in obtaining an adequate supply is considered.

The physical properties govern the methods of manufacture, and in the case of the copper bands the requirements make the difference between cast or rolled material. In the larger sizes of bands these specifications are all the more important, particularly when the lands of the rifling of the gun become worn, and form a small bearing area which, when inferior material is used, tears and rips.

Formerly the French artillery specifications not only specified the analysis of cartridge brass, but the brands of copper and spelter which would be accepted were also named. This was caused to try and prevent the use of spelter containing lead, iron and cadmium. These undesirable elements have various effects, such as reducing the ductility, etc. Cadmium and its effect in small proportions has been investigated very little, but apparently the melting point of brass is so high that the cadmium volatilizes and the remaining percentage has little effect due to the difference in the melting points which seems to be the principal trouble.

Small Bands Cast

In the case of the smaller sizes of copper bands, the specifications can be met with cast copper, while the larger sizes must be subjected to rolling or other treatment. The smaller bands are top poured and cast in steel tubes with hay loam cores. The hay is not twisted into a rope, but is picked out from the bin and laid in place covered with loam.

The cylinders are turned on the outside and cut to lengths, after which the bands are chucked and a cleaning cut made on the inside. The larger sizes must be rolled or worked, and in some cases the method of procedure is to cut out the blanks, which are about 36 in. dia. cup and draw similar to cartridge case work, care being taken to anneal between operations at 1,500 degs. F. A noticeable feature in the drawing operation is the amount of play on the cross-head or ram supporting the punch. Lubrication is used, as in brass drawing.

Melting the Copper

The copper for these purposes is produced in an oil furnace, pure scrap, as near as possible to obtain, being used, including cuttings. The refining is done

by covering the surface of molten copper with charcoal and by rabbling or puddling with a green pine pole, possibly 5 inches in dia. and 15 ft. long. This poling causes steam and gases to form from the green wood, reducing the oxides and impurities. The slag which forms on the surface, and which contains the impurities, is taken off and test buttons are taken to see if the process has been carried far enough. These buttons are about 1½ in. in diameter. The condition is judged by fracture, which should be pink, and not red, and by the shrinkage or lack of it. The latter is termed pitch, which means the shape of the top of sample, i.e., convex, straight or concave. What is required is a slightly concave surface, and if it is not as desired, poling must be continued, and if too concave, oxygen must be added and the process repeated, but this requires considerable mechanical skill to restore this overpoled copper.

The slag obtained from the refining contains good metal, and should be remelted in a cupola with suitable fluxes and the reclaimed copper subsequently refined.

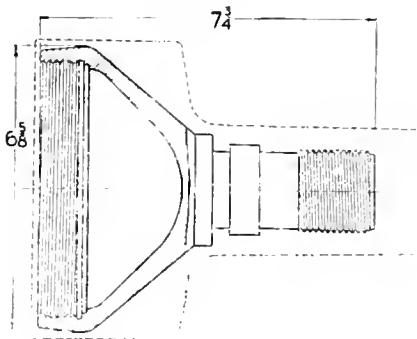

FIG. 1.

The medium-sized bands are made from castings about 9½ in. dia. x 9½ in. long, which are cast in metal molds on a rotary platform, after which they are annealed at 1,500 degs. F. for half an hour, and the cupping and drawing operations which are performed on horizontal hydraulic presses follow.

The brass for cartridge cases is composed of from 15 per cent. to 40 per cent. scrap, depending on the available supply, but no fine cuttings or dross are included. Melting is done in crucibles heated by coal in open pit types of furnace.

Pouring Billets

The molds, which are cast iron, hinged at bottom, with clamps at top, which are part of the pouring basin, make a billet about 1¾ x 9 x 30 in. Pouring is from the top through gates about ⅝ in. dia., and the temperature and process is watched so carefully that there is very

little discard, if any. The billets are now taken to a high-speed machine, which cleans off all dirt or dross which may have gathered on the sides during the casting operation.

The rolling operation consists of eight passes, with a reduction of ¼ in. per pass. After passing the first three passes a lubricant is applied.

In blanking the finished sheets a shear is used behind the punch and die; in this

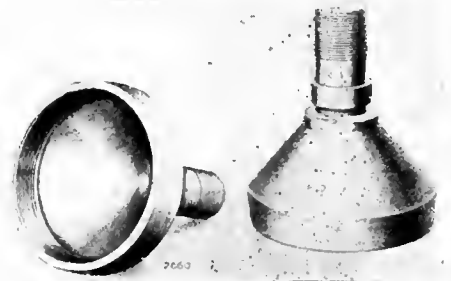

FIG. 2.

manner the trimming permitted handling for further blanking, and the scrap was automatically cut to correct size for subsequent remelting.

MACHINING RECUPERATOR DETAILS FOR FIELD GUNS

Herbert's Monthly.

THE efficiency of the modern field gun is measured, not only by the number of rounds which can be fired per minute, but also by the steadiness of the gun, which enables it to keep on the target, thus reducing the time required for re-sighting. The field guns of 25 years ago had no means of absorbing the recoil, and had to be re-sighted after each shot. Designers of artillery have therefore paid a considerable amount of attention to the buffer and recuperator, which absorb the recoil of the barrel, and bring it back to the firing position; the latest designs being remarkably efficient. Many of the details are very suitable for production on combination turret lathes,

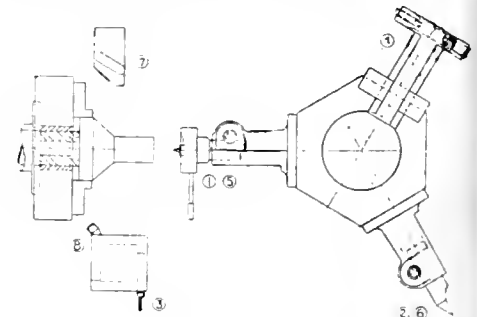

FIG. 3.

and capstan lathes, and one of these of more than usual interest is the adapter for breach lug shown in Figs. 1 and 2. The material from which it is made is a

steel forging of about 40 tons tensile strength, which is shown circumscrib-

tion turret lathes, and are three in number.

moved from the shank end, and the taper rough formed. At this operation, the forging is in the rough state, the roller carriers are not required, and are removed from the centering tool. The lever feed to the centering tool is very useful on the larger turret lathes, as it prevents breakages to the drills.

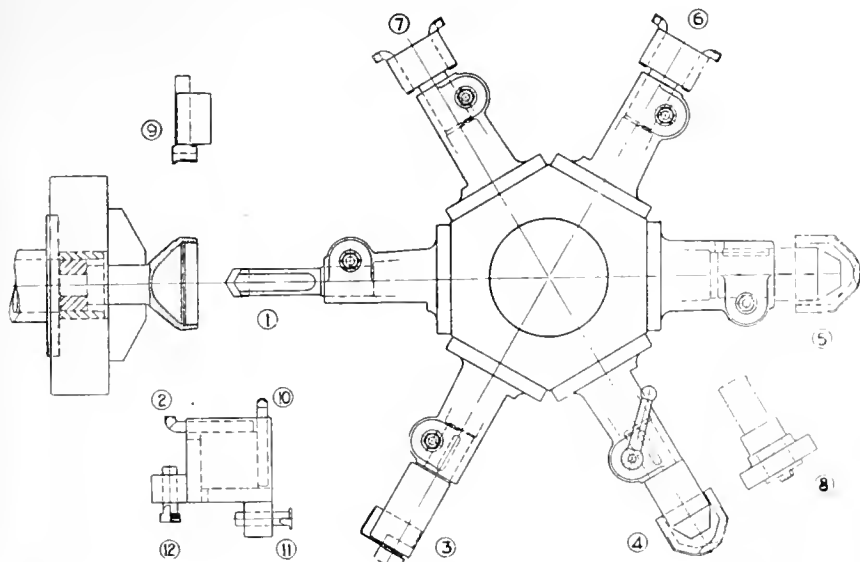

FIG. 4.

ing the finished work in Fig. 1. It will be noted that there is rather a large

The first operation, which is something in the nature of a preliminary roughing

1.—A roller steady centering tool for centering the end of the forging. As the forging is in the rough state, the roller carriers are not required, and are removed from the centering tool. The lever feed to the centering tool is very useful on the larger turret lathes, as it prevents breakages to the drills.

2.—A dead centre for supporting the end of the work while tool 3 is cutting off.

3.—A cut-off tool which removes the superfluous metal from the forging, and steps down to start the boxtool.

4.—A patent inverted roller steady boxtool, which turns the shank.

5.—The centering tool is used again for re-centering the shank.

6.—The dead centre is used again for supporting while forming the taper.

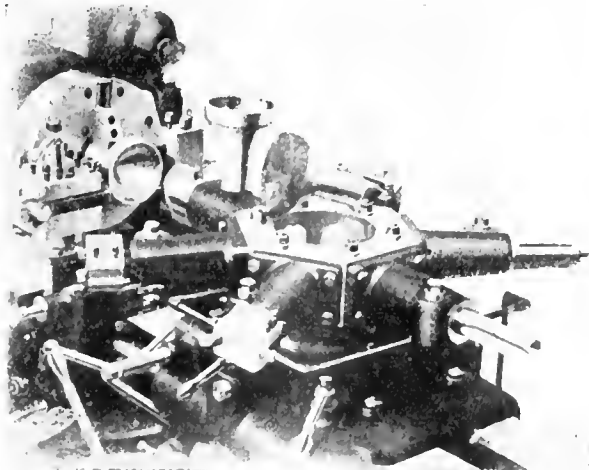

FIG. 5.

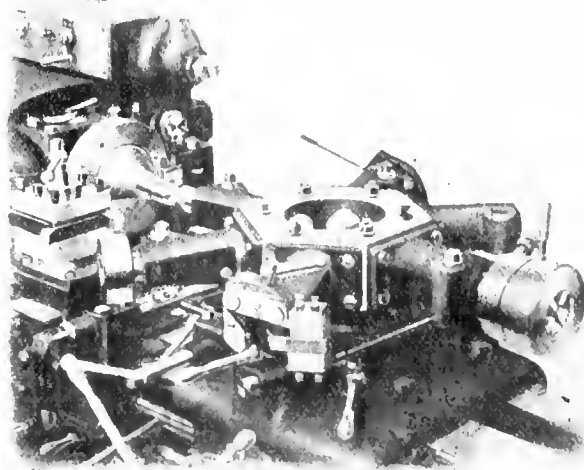

FIG. 7.

amount of metal to be removed, especially from the taper portion and from the

operation, is shown in Fig. 3. The shank is rough turned to provide a good grip

7.—A taper form tool carried in a special tool holder on the back of the cross slide, for roughing out the taper.

8.—A facing tool for the end of the shank, which removes the centre hole.

The time for this operations is 15 minutes.

At the second operation, which is shown in Fig. 4, the work is gripped by the shank rough turned at the previous operation, with special jaws in the Coventry chuck. The jaws are made longer than usual, so as to get the strongest grip, as the work of this operation is heavy. The sequence of operation is as follows:—

1.—A patent straight flute drill with inserted spiral cutter for drilling a pilot hole for counterbore 3.

2.—A rough turning and facing tool, which operates simultaneously with 1.

3.—One of our standard type counterbores, which opens out the hole as deep as possible.

4.—A rough spade tool for form boring.

5.—A finish spade tool.

6.—A rough boring bar for the three diameter and the plain diameter beyond.

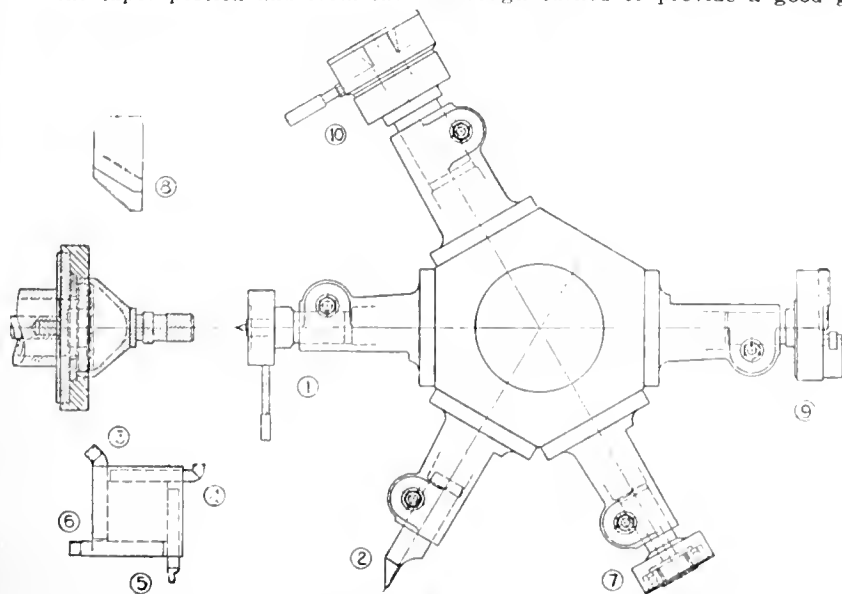

FIG. 6.

end of the shank. The lathe operations are handled on Herbert No. 9 combina-

for the chuck jaws used at the second operation; the superfluous metal is re-

7.—A finish boring bar for the same diameters.

8.—A revolving steady bush interchanged with 4, for supporting during the forming operation 9. The interchanging is simplified by fitting a clamping handle to the pad bolt in place of the usual hexagon nut.

9.—A form tool for the external taper, carried in the standard back tool-post.

10.—A small form tool used for finish facing the end, forming the small external radius, and chamfering the mouth of the hole.

11.—An internal recessing tool for the back of the thread.

12.—An internal chaser. The machine set up for this operation is shown in Fig. 5, the machining time being 50 minutes.

At the last operation, as shown in Fig. 6, the work is held on a screwed draw-back arbor peg, and the sequence of the tooling operations is as follows:—

1.—A centering tool for re-centering the end of the shank.

2.—A dead centre for supporting.

3.—A turning tool which turns the thread diameter, and the intermediate collar.

4.—A finish turning tool for turning the large diameter.

5.—A form tool for the narrow groove, and for producing the small diameter at the end of the thread.

6.—A form tool for the wide groove.

7.—A ball-bearing steady bush holder, which supports on the thread diameter, whilst forming with tool 8. For accurate forming it provides a better support than the dead centre.

8.—A taper form tool carried in the same tool post as used at the first operation.

9.—A roller steady and rounding tool.

10.—A Coventry patent self-opening diehead. The time for this operation is 25 minutes, and the machine is shown in Fig. 7.



FABRIC BRAKE AND CLUTCH LININGS

By L. E.

THE extent to which fabric has replaced all other substances as a friction material for brake and clutch linings is hardly realized even by engineers. Practically every automobile, for example, now has fabric lining on its clutches and brakes, whilst all the underground railways in London and Paris, as also in the Glasgow subway, now use fabric brake-linings in place of metal blocks. Mr. J. Oswald, of Glasgow, stated that cotton brake-blocks were first tried on horse-cars and were found to have points of very great superiority over wood, especially as regards their efficiency when heated by friction.

Since that time great improvements have been made in the manufacture of friction fabrics. The bonding cement has

been rendered more heat proof, and a process has been developed whereby the burning point of the fabric itself is raised 75 per cent.

Fabric lining is of two main kinds—that made of cotton, and that made of asbestos. According to Mr. Oswald, the cotton fabric has the highest co-efficient of friction, i.e., 0.5 to 0.7, and is capable of absorbing much greater work in foot-pounds per sq. in. at a given pressure than asbestos material. The co-efficient of friction rises with increased temperature, and is practically unaffected by oil or water. In actual test results obtained by the National Physical Laboratory on cotton material, the work absorbed in foot-pounds per sq. in. per minute was 72,000 dry and 70,000 when lubricated, the pressure being 39 lbs. dry and 160 lbs. lubricated.

The choice between cotton and asbestos is determined in part by the amount of heat that is likely to be generated. The heat limit with cotton is 400 deg. F., and in all cases where this heat limit is likely to be exceeded it is advisable to adopt asbestos material. The co-efficient of friction of this material is 0.3, and it is remarkable that it practically remains constant under varying conditions. Its value lies in its great heat resisting qualities, which recommend its use on exceptionally heavy and prolonged braking or similar duties. Owing to its nature, asbestos material is usually reinforced with brass wire, which makes it more expensive than cotton. Failures with fabric linings are not unknown, but the majority of them Mr. Oswald ascribes to preventable causes: (2) The use of wrong material; (b) to failing to keep the fabric face clear of the opposing face when the brakes are out of action; (c) failing to ensure that the fabric is kept well home when applied, or, in other words, "followed up"; (d) incorrect fixing of linings to the engaging media; also (e) through expecting too much from brakes which have been under-dimensioned by the makers for the duties they have to perform.

Collieries, it appears, are now taking up fabric linings extensively for brakes on main winding engines and haulage gears. Their use saves the rope considerably on account of the smoother action, the upkeep cost is even less than with wood, and there are further advantages in the shape of improved control and speedier working.

The immediate reason for introducing fabric linings for the brakes of the underground railways is interesting. Iron brake blocks give off an amount of iron dust which totals to surprising figures. Three-quarters of a ton of brake-dust per mile has been proved to be produced every month in the New York subway. This dust not only short-circuits the electrical signalling apparatus, and causes stoppage of trains daily, but as it settles on the track the oil from the motors becomes mixed with it and forms a highly inflammable mixture. It was the accumulation of this and the red-hot sparks from the metal blocks which caused the Paris fire a few years ago,

in which 480 people lost their lives. Fires in London underground railways have also been attributed to this cause. The rapid running of the trains throws off oil from the motors under the coaches and the atmosphere being charged with metal dust, a very inflammable mixture is scattered all over the train.

It was partly to prevent these troubles that the cast-iron blocks were abandoned in favor of cotton linings. Since their introduction not a single fire has been reported on any of these railways. Continued use led to the discovery that there was no appreciable wear on the tyres and rails, these being highly burnished. A further very important result is that since fabric linings have been used, rail corrugation and flats on wheels, which commonly existed with the use of metal brake blocks, have disappeared.



THE EFFECT OF STORAGE ON COAL

By S. D.

IT IS a matter of obvious and common knowledge that if stored coal be allowed to generate spontaneous heat its calorific value will suffer heavily, and for that reason storage under water has been from time to time advocated and practised; but there is also a widespread assumption that apart from spontaneous heating coal stored in the open deteriorates sensibly in the course of a year or two as a result of disintegration accompanied by chemical loss. Tests carried out over the last five years point to the entire fallaciousness of that belief, so far as any rate as the gas-making properties of coal are concerned.

A truck load of each of two grades of gas coal were set aside five years ago for the purpose of the experiment. The coal was stored in the open, in bins nine feet deep, provided with separate compartments, and each succeeding year a compartment was cleared and the coal tested in 400 lb. retorts. The results fluctuated somewhat from year to year, but after allowing for certain variables in the working of the retorts, the conclusion was arrived at that no deterioration in the gas-making quality of the coal had taken place even at the end of the fifth year.

The main body of the coal suffered little physical change during the five years. The top six inches had crumbled considerably but even in this top six inches chemical analysis failed to reveal any material change, even after five years' weathering.

It may be taken, therefore, that gas coals can be kept for five years exposed to fairly severe climatic conditions and be none the worse for it, provided there is no internal heating of the mass. It may be pointed out, however, that the conclusion would not necessarily hold good in the case of steam coal, as the crumbling of the upper layer would yield a certain amount of fine coal which under average steam boiler conditions would be apt to be drawn over the top of the fire and so pass unburned into the flues.

Standardization Applied to Cargo Boat Machinery

By D. B. Morison

The industrial problems of the future must be faced, and faced quickly — moreover, they must be solved, and solved quickly. The onus of responsibility falls primarily on capital, in the provision of standardized organization, direction and equipment, whereby the best is accurately determined and the best is progressively maintained; thereafter capital and labor must co-operate in standardizing rapid production, so that good general trade may be promoted by steady employment at high wages to the lasting benefit of the industries concerned and the general welfare of each individual community, and the nation as a whole.

ALTHOUGH it is imperative that maximum effort, individual and collective, should be concentrated on winning the war, it will be well if our energies can be so directed that, without in any way prejudicing the main issue, they may be helpful towards a solution of the stupendous industrial problems ahead of us, and in avoiding the dangers of "too late." In engineering and shipbuilding the period of grace will be extended by reason of the general shortage of tonnage, but the deluge of world competition will be with us ultimately as sure as night follows day, and our success or failure will depend entirely on the use we make of the time and opportunity between now and then.

Capital and Labor

It is futile for capital to expect that labor will consent to any great reduction in wages. It will be equally hopeless for labor to expect the maintenance of the present high rate of wages without concessions on its part. Therefore, let both capital and labor seek whether by joint endeavor it will be possible to pay high wages in the future and yet maintain our trade. The requisites are, first, a candid acknowledgment by labor of the economic law that good general trade is dependent on maximum produc-

tion, and, secondly, capital must recognize that maximum production entails correspondingly high pay. Capital and labor must realize that their interests are parallel, not divergent. Assuming that this fundamental principle is accepted, then the onus of organized preparation falls on the employer, as, unless unrestricted effort is well directed, its standard of useful efficiency will be so low that ultimate failure is inevitable. There can be no industrial success in this country of the degree demanded by the obligations of our national indebtedness without the full employment of labor at the highest standard of useful efficiency. Such a standard is only possible with the most perfect mechanical equipment and the most efficient general organization and management on the part of the employer, and with unrestricted effort and correspondingly high wages on the part of the employed. The manufacture in multiple of an arbitrary design is not standardization; it is merely repetition with the object of obtaining greater output. To standardize is:—

"Accurately to determine the best—progressively to maintain the best—and to produce of that best the greatest quantity by means of organized specialization in labor, in methods, and in machinery."

Progressiveness in Standardization

Progressiveness in standardization with regard to designs depends on how

a self-binding reaper, the desired effect having been obtained, progress can only be associated with means for reducing the cost of manufacture or increasing the rate of work. The economic effect of obtaining the greatest possible power from steam by means of an engine is of such vast importance that the determining of the best, and the progressive maintenance of the best, are factors which also determine whether any given type shall continue to exist. Consequently the initiation of a standardized marine engine requires extraordinary care and ability in order that the standard shall be unsurpassable in efficiency both thermally and mechanically.

Propelling Machinery Standardization

A single mistake in determining the best in a standard engine prejudices for its entire life the commercial value of the ship that it drives, whether the mistake be reflected in steam inefficiency or mechanical inefficiency. It would seem, therefore, to be of paramount importance that the initial decisions should be vested in a body of marine engineers who are life specialists in the design, the manufacture, and the running of cargo boat machinery. In other words, the engine must start off as the leader of its type, it must maintain this lead, and the

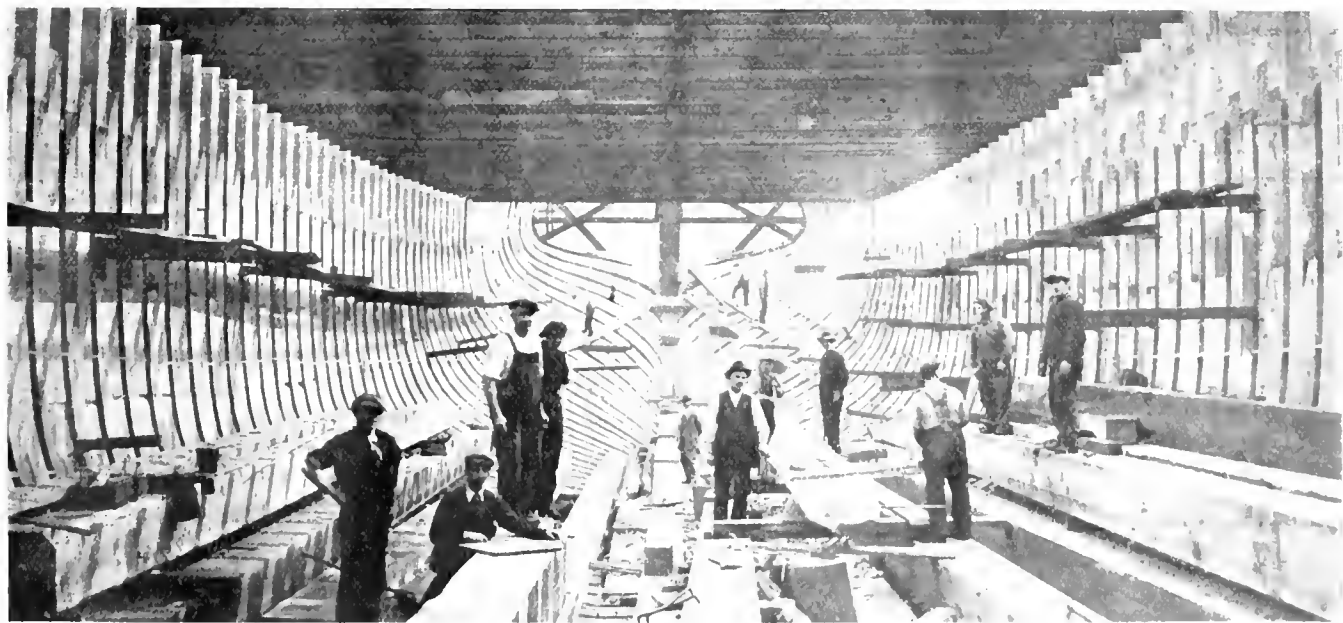

INTERIOR OF HULL UNDER CONSTRUCTION, AUXILIARY POWER SCHOONER "MARGARET HANEY."

tion, and, secondly, capital must recognize that maximum production entails correspondingly high pay. Capital and

*From a paper read at the spring meeting of the Institution of Naval Architects, March 28, 1917.

labor must realize that their interests are parallel, not divergent. Assuming that this fundamental principle is accepted, then the onus of organized preparation falls on the employer, as, unless unrestricted effort is well directed, its standard of useful efficiency will be so low that ultimate failure is inevitable. There can be no industrial success in this country of the degree demanded by the obligations of our national indebtedness without the full employment of labor at the highest standard of useful efficiency. Such a standard is only possible with the most perfect mechanical equipment and the most efficient general organization and management on the part of the employer, and with unrestricted effort and correspondingly high wages on the part of the employed. The manufacture in multiple of an arbitrary design is not standardization; it is merely repetition with the object of obtaining greater output. To standardize is:—

leadership must be generally acknowledged by cargo boat machinery experts. The incorporation in one design of the latest and best practice as affecting steam efficiency and running costs would

provide a measure, but the measure itself must be tested and adjusted by continuous research, both technical and practical, on organized lines, so that it is always "The Standard."

Determining the Standard

Failing a Government Engineering Bureau for the whole country, the engineering institutions would appear to be the best means to the desired end. An experiment in this direction has recently been made by the North-East Coast Institution of Engineers and Shipbuilders. The members and council have commenced on very conservative lines by preparing a guidance specification for triple-expansion engines for cargo boats, based on the best practice of the various specialized builders on the coast. It is proposed to begin on simple lines for this year, but an annual revision will be made in order that the specification may be gradually extended and kept thoroughly up to date, with a view to securing maximum rate of progress in technical advance, and commanding the confidence and promoting the ultimate interests of all concerned, viz., of the engine builder, the shipbuilders, and the shipowner. Other specifications on similar lines are to be prepared for quadruple engines, geared turbines and internal combustion engines.

Assuming that in the general problem of standardization this guidance specification of the North-East Coast Institution represents the best now obtainable, the next step is to provide means whereby there shall be progressive improvement by continuous investigation and research, supported by organized and collective practical experience. With regard to the latter, it is not sufficient that the engine builder gets rid of his goods on the day of the trial trip. There should be some system of co-operation between the engine builder and shipowner, whereby the general results in coal economy and costs for repairs over a prolonged period, certainly beyond the usual six months' warranty, are recorded and rendered available. In order to secure the funds for carrying out this scheme, it has been suggested that the cargo boat engine builders of the North-East Coast should be invited to adopt the specifications at a small fee per horse-power. As the money so collected would be entirely devoted to promoting the progress of the associated industry, it is hoped and expected that there will be an enthusiastic response.

Auxiliary Machinery

In the matter of auxiliaries, the Research Committee appointed by the Council of the North-East Coast Institution will exhaustively test approved apparatus connected with a marine installation, and publish in their "Transactions" the results obtained. This will secure a reliable means of ascertaining the true performance of any apparatus so tested, and as the results will carry the hallmark of the Institution for accuracy, the value of the scheme to the industry generally is obvious. In the matter of boilers

and shafting, complete standardization of marine machinery is blocked, because the Board of Trade, Lloyd's Registry, and the British Corporation issue independent rules, which are based on physical facts as a constant and individual opinion as a variable. Just a very little co-operation and mutual sympathy would enable all the existing differences to be adjusted to the great advantage of the many industries involved.

When Lloyd's Registry revised their rules some years ago, they requested the assistance of a committee of experts selected by the leading marine engineering institutions. This committee has been very successful, as the various members, all of whom occupy leading positions in the several shipyards and engine works, are in such direct touch with practice that their experience establishes mutual confidence, to the great benefit of all concerned. A similar committee of experts was appointed by these institutions about the same time, with the object of providing a means whereby the many irritating disputes and misunderstandings, which so frequently arose some years ago between the Board of Trade and the manufacturers, could be overcome, the collective technical experience of the members being available in the event of new rules being issued or old rules revised. Each member of the committee was prominently associated with a shipbuilding yard or a marine engineering works, and all gave their services with enthusiasm, although often at great personal inconvenience.

In any progressive country on the face of this earth except our own, such a committee would have been welcomed, and its expert capacity officially recognized and utilized to the fullest extent for the common good; but the traditional antagonism to innovation, no matter how desirable, has prevailed. For twenty years this committee has given of its best to the cause of progress. It has never received adequate recognition or encouragement from the Department of State it was appointed to assist. It is gratifying to record, however, that a serious attempt is now being made to devise some mode of procedure for making full use of the existence of this committee in the national interests.

Assuming the various surveys decide to harmonize their rules so that standard design, scantlings, and physical properties of material may prevail throughout the range of cylindrical boilers as now supplied to cargo boats, the economic effect on the manufacture of the material and the building of the boilers would be very pronounced. It would at once be possible to prepare a series of standard designs, with accompanying specifications for plates, furnaces, tubes, stays, rivets, etc. The steel manufacturer could estimate the probable demand, produce in bulk, and give immediate delivery. The boiler builder would be freed from the delays arising from the preparation and submission of designs, and would simply order from the scheduled list—receive the goods exactly when required, and proceed with the manufac-

ture with an economic continuity hitherto impossible. The following are examples of divergence between surveys:—

Divergence in Boiler Rules

1—For a single-ended boiler, 15 ft. 6 in. mean diameter, 11 ft. 6 in. long, 180 lb. working pressure, thickness of shell 1 3/32 in., tensile 28½ to 32½ tons per square inch, diameter of rivets 1 3/32 in., pitch of rivets 9½ in.

Working Pressure of Shell

	Pounds.
Board of Trade	= 183
Lloyd's Registry	= 210½
British Corporation	= 204½

2—For the working pressure for a suspension furnace, 3 ft. 10 in. inside diameter, 5/8 in. thick:—

	Pounds.
Board of Trade	= 185.3
Lloyd's Registry	= 200.5
British Corporation	= 196.5

An examination of the tables of pressure for these furnaces reveals to the curious that for thicknesses below 9/16 in., the Board of Trade allows a greater working pressure, the thinner the furnace, than Lloyd's, and for furnaces over 9/16 in. thick Lloyd's allow a greater working pressure, the thicker the furnace, than the Board of Trade. Arbitrary requirements also often involve unnecessary cost, as, for example, limitation by the Board of Trade of rivet pitch to 10½ in. with a tensile of rivets of from 27 to 32 tons necessitates an increase in shell tensile for large boilers, for which abnormal extras have to be paid to the steel makers.

A brilliant example of what can be achieved by well-directed collective efforts is the standardizing of stationary boilers in the United States of America by a committee of experts appointed by the American Institution of Mechanical Engineers. In this connection the following extract from a speech by the late president of the Board of Trade would seem to be appropriate: "It will, in fact, be apparent to all close observers that a country which fails to regulate and foster its industries in the national interest cannot in the nature of things long survive the rivalry of another country where the industries are so regulated and fostered."

The Shafting Anomaly

The only detail of the engines proper affected by the surveys is the shafting, and the following is an analysis for a set of triple-expansion engines with cylinders 25 in., 41 in., 68 in., by 48 in. stroke and 180 boiler pressure:—

Diameter of Crank and Thrust Shafts

Board of Trade	= 12.76
Lloyd's	= 13.32
British Corporation	= 13.08

Diameter of Tunnel Shaft

Board of Trade	= 12.12
Lloyd's	= 12.69
British Corporation	= 12.42

In determining the diameter of propeller shafts, each of the three surveys adopts a different basis. Lloyd's and the

British Corporation consider the diameter of the propeller—the British Corporation the block coefficient of displacement of the vessel, whilst the Board of Trade consider neither. Assuming a propeller diameter of 17 ft. 6 in., and a block coefficient of displacement of .78, at four-fifths moulded depth, diameter of propeller shaft is by:

Board of Trade	=	13.47
Lloyd's	=	14.29
British Corporation	=	14.67

That is to say, a shaft to the Board of Trade requirements would be deemed 22 per cent. too weak by the British Corporation, and 16 per cent. too weak by Lloyd's. In practice the shafting of a cargo boat is practically never made to the rules of the Board of Trade, as when the machinery is built to the Board of Trade survey it is invariably associated with either Lloyd's or the British Corporation. If, therefore, these two surveys could see eye to eye, and bring their shafting rules into line, a great advance would be made towards completely standardizing the reciprocating engines of a cargo boat.

With the advent of the geared turbine, and its probable extended use in the near future, it might reasonably have been expected that the various surveys would at least have formulated rules on a common basis. Such, unfortunately, is not the case. Lloyd's and the British Corporation adopt shaft horse-power, the Board of Trade indicated horse-power; Lloyd's rule giving the larger shaft. This state of affairs is perhaps not surprising in view of the fact that aloofness has hitherto been a national characteristic. Force of circumstances will compel us to modify this attitude, and to recognize that friendly co-operation will be the factor which will determine whether we sink or swim in the coming great race for industrial supremacy.

Industrial Methods Revolutionized

Broadly speaking, industrial methods in Great Britain have been completely revolutionized since the war began, because we have been driven to recognize the dominating influence of intelligently directed energy as a factor in the economies of production, and it is unquestionable that the magnificent response to the national demand for colossal quantities of war material resulted from the cultivation of intelligent effort and concentration of organized method. The actual ascertainment of what is possible has been accompanied by an industrial awakening after a dangerously prolonged sleep, and as a fortunate consequence we shall be immeasurably better able to face possibly perilous competition than ever before, provided we sustain our efforts and profit by our experience. Intelligent direction increases the useful efficiency of labor enormously, so that by concentrating on method, employing the most suitable equipment obtainable, and organizing physical effort, such a high rate of production can be obtained as to demonstrate without a shadow of doubt the certainty of an employer being able to pay high wages, but labor must respond with unrestricted production and enthusiastic co-operation. This does not

mean great physical effort by labor, but reasonable and continuous effort during a full working day.

In this connection the war has revealed the high standard of useful efficiency attained by women, especially as workers of machine tools, and to their lasting credit be it said that the steadily progressive production in many munition factories is due entirely to the unceasing desire on the part of the women always to do their best. To obtain all that is commercially possible from standardized production it is necessary to manufacture continuously a given article in the best way by the best means at the best speed, whereby the efficiency of each factor is unity. The greater the number manufactured, the less becomes the percentage of attendant expenses. Therefore, in cases where the value of the article is considerable, and the demand great, the commercial success attainable may be phenomenal. Quantity is a controlling factor in all cases, so that maximum success in the standardization of marine engines can only be obtained by the co-operation of the greatest number of builders.

Classification of Propelling Machinery Parts

Merely as an illustrative example let us consider the position on the North-East Coast. The various engineers who specialize in cargo boat machinery produce collectively, say, 200 sets of reciprocating engines per annum. The following is a rough classification of the parts of the main engines only:—

MAIN DIVISIONS OF ENGINES	
I—Cylinders	
Cylinders	600
Covers	600
Liners	200
Pistons	600
Valves	600
II—Columns	
Columns	1,200
Guide plates	600
Guide bars	1,200
III—Bed-Plate	
Bed-plate	200
Bearings and keeps	1,200
M.B. bolts	2,400
M.B. nuts	4,800
IV—Main Forgings	
Piston-rods	600
Connecting-rods	600
Main bolts	1,200
Cranks	600
V—Valve Gear	
Excentrics	1,200
Excentric straps and rods	1,200
Radius links	600
Drag links	1,200
Reversing shaft	200
VI—Condenser	
Body	200
Doors	100
Water head	200
Tube-plates	400
Tubes	250,000
Ferrules	500,000
VII—Pumps	
Air pump	200
Circulating pump	200
Feed pump	400
Bilge pump	400
Sanitary pump	200
Levers, etc.	400
Drag links	800

Taking the steel forgings and adding the thrust, tunnel, and propeller shafts, the approximate total weight would be about 14,000 tons. If this amount were concentrated at a convenient centre, the steel cast, the ingots forged, and the forgings rough turned, and if the works were of such size that this demand were only a portion of its output, then the cost

of production would be so low as to enable the engine builders to buy cheaper and to sell cheaper. The destination of these forgings for machining would depend on available facilities and transport, the object being a continuity of operation under the most favorable conditions possible. The heavy castings would be produced from standard patterns, all prepared in consultation with the iron-foundry management, and the design being standard, the foundry management could with confidence provide the best labor-saving tackle. When delivered to the engine works the castings would be dimensioned by means of standard apparatus, and machined from continuous supply. The tens of thousands of engine valves, fittings, and other details would be classified and manufactured in bulk in specially equipped departments in the best ways, by the best means, and at a cost quite unapproachable by present methods.

Purchase, as Against Manufacture

In cases where an aggregation of parts is not sufficient to secure the benefits of production in bulk, those parts should be purchased from manufacturers whose business it is to produce such parts. For example, take condenser ferrules. A condenser ferrule machine can produce 400 per hour. Even if the yearly demand were half a million the machine would produce them in about 1,200 hours, or, say, 24 working weeks, thereby being operated at half its capacity. Complete standardized production of ferrules and similar details would involve the use of the greatest number of automatic machines that could be supervised by one skilled operator and one or more unskilled assistants. One skilled machine setter and three unskilled assistants could probably manage up to 20 automatics. Therefore, the difference between one machine working half its time with one operator and 20 machines working continuously with four operators is an indication of the possible savings by organized manufacture in bulk.

Take as another example the large bolts, such as are required for main bearings, piston rods, and connecting rods, and which would aggregate about 10,000 per annum. So great a number of practically similar articles would admit of the purchase of special turret lathes capable of finishing bolts up to 5 in. diameter, with provision for completing all operations from the first rough cut to the final screw-cutting and finishing, and if the number of machines were adjusted to maintain their full working capacity the cost of production would again be very favorable.

These few examples indicate the possibilities of standardized manufacture as applied to cargo boat engines. The system is co-operative, and is the direct antithesis in its inception and in its results to the destructive competition which has been so rampant and ruinous in past years. In manufacture, the day of conservative and scattered individual effort is over—it leads to certain ruin. Success lies only in concentration by collective effort and the pooling of individual interests for the common good.

PROGRESS IN NEW EQUIPMENT

A Record of New and Improved Machinery and Accessories for the Machine, Pattern, Boiler and Blacksmith Shops, Planing Mill, Foundry and Power Plant

REVOLVING MACHINE STANDARD
THE device illustrated is designed to conserve space and afford increased convenience of operation in metal working shops where various machines are in use intermittently by different

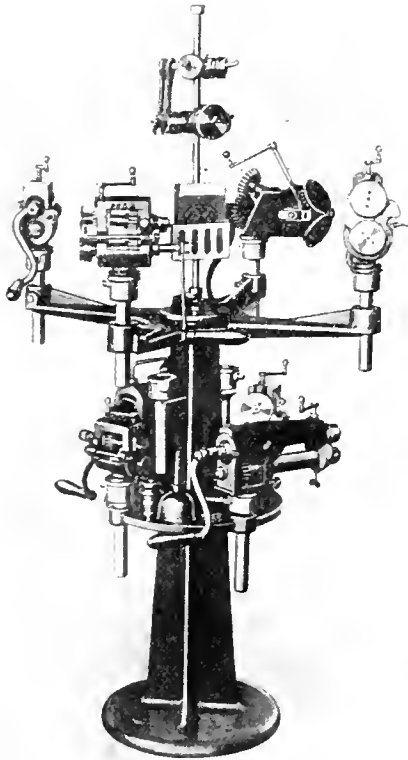

REVOLVING MACHINE STANDARD.

workers. It is known as the Hold-all revolving machine standard, and is built by the Peck, Stow & Wilcox Co., Cleveland. A revolving turret is fitted to

the upper part of the standard with accommodation for four machines, the proportions being such that four operators have ample room for simultaneous use of the machines; the machine holders can also be raised, lowered or revolved to suit the convenience of short or tall operators or in accordance with the work in progress. The distance from floor to working edge of machine rolls is 40 in. A convenient locking lever is provided for retaining the turret in any position.

The lower shelf has accommodation for four additional machines interchangeable with those in the revolving turret. It also provides handy accommodation for oil cans, tools, etc. Two larger machine posts are accommodated on brackets below revolving turret, making a total of ten posts carried by the standard. The shipping weight of the device is 268 lbs.

PLATE PUNCH TABLE

THAT the question of increased output from shipbuilding yards is receiving attention from makers of various items of equipment is evidenced by the engraving herewith, illustrating the Lysholm plate punch table which is being built by the Norbom Engineering Co., Philadelphia. It is designed for the purpose of facilitating the punching of steel plates, and is constructed in the form of a traverser of approximately twice the maximum length of plate to be handled. Four tracks are provided on which the table travels to and from the punching machine.

The plate is supported by ten shafts fitted with discs on which the plate rests, the four shafts at the centre being geared together through the medium of chains and bevel gears, so that by raising the lever in his right hand the operator

moves the ratchet plate to the left, and by depressing the lever, moves the plate to the right. A similar lever at his left hand coupled to a shaft lower down causes the traverser to move bodily to or from the punch. The punch itself is operated by a trip pedal at the operator's foot, or otherwise as desired.

Roller bearings and similar mechanical refinements are employed throughout to insure ease of operation to such a degree that one man can easily handle plates in half the time required with older methods. The size of plate which can be handled is from $\frac{1}{4}$ in. to 1 in. thick up to 25 ft. in length and 8 ft. wide.

ANTI-ACID VALVES

THE Lunkenheimer Co., of Cincinnati, Ohio, state that during the past year there was an exceptionally good demand for valves made entirely of iron for use in handling cyanides and other solutions which attack metals having copper as their basic element, and which consequently could not be handled by brass valves or valves having any part made of brass. This company, we understand, have supplied a large number for use in dye and chemical manufacturing plants, but the demand was not confined to these sources, as quite a number were also supplied for use in mines, oil refineries, tanneries, pulp and chemical fibre mills, canning and packing establishments, etc. In the manufacture of these all-iron valves, a composition is used that is claimed to be exceptionally free from impurities, resulting in solidity of grain structure which insures great strength and makes the castings more resistant to corrosion and chemical attack. For handling the more severe solutions, such as caustic soda, caustic potash, soda-ash, and other similar alkaline liquids, the company employ a composition known as "Lunkenheimer Nickel-iron." The exceptional acid resisting qualities of this metal and the long and satisfactory service rendered has led many to use valves made of this material even for the weaker solutions. The standard line of Lunkenheimer All Iron Valves includes "Ferrenewo" Globe, Angle, Cross, and Check Valves in sizes as small as $\frac{1}{4}$ -in., and up to 2 inches; cross valves, sizes 2 to 12 inches, inclusive; "Clip" gate valves, as small as $\frac{1}{2}$ inch and up to 6 inches; "Victor" gate valves, sizes 2 to 12 inches, inclusive; quick opening gate valves with lever, sizes $\frac{1}{2}$ to 12 inches, inclusive, and check valves up to 12 inches inclusive.

UNIVERSAL CUTTER AND TOOL GRINDER

SIMPLICITY of construction combined with a wide range of work capacity is a prominent feature of the grinder shown

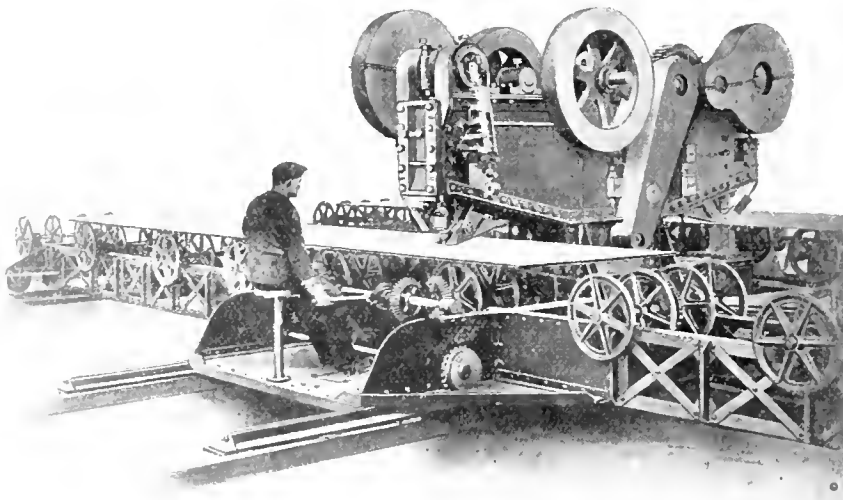

PLATE PUNCH TABLE.

in the accompanying illustration. It is designed for grinding small tools, fixtures, gauges, etc., and will admit work up to 10 in. dia. and 15 in. between centres. All feeds are by hand, the cross-

cutting of the gear may easily cause the burden of the load to be taken by only a small part of the total width of face at a time; the incidence of the load swaying from side to side of the gear at each

parts are so proportioned that this lateral deflection can at no time involve fibre strains which could possibly cause destructive fatigue. A very small amount of this lateral deflection is sufficient to afford the desired distribution of load, and this amount can easily be given without approaching dangerous periodic strains.

The commercial development of this gear is already well advanced. About 72 sets of the gearing have been applied to turbo-generator drives, and some of these have now been in service one and a half years; about seven sets have been fitted to ships which are now in service, some of them having been long voyages. It is stated that in all of this practical experience no case of trouble with gearing has been developed, and no appreciable deterioration of gears has been observed. Contracts are said to have been closed for machinery for the propulsion of 70 ships, aggregating 215,200 horsepower.

Whether self-equalising devices of one kind or another are really essential to efficiency in turbine gearing depends in some measure upon the degree of accuracy which can be reached in the gear cutting process. While the developments with flexible trunnions and wheels have been going forward, important improvements have been made in the method of cutting large gears, whereby the errors in the master wheels are broken up, and so distributed over the surface of the gear as to be practically eliminated.



COOLING IRON CASTINGS

WHERE soft castings are wanted, the rate of cooling has very much to do with the matter. Assuming that the silicon and carbon content are properly proportioned, slow cooling gives the desired results owing to the fact that the carbon very largely separates as graphitic carbon. To secure the best results the sand should be used as dry as is possible to produce a good mould, and there should be a good body of sand of a porous character to back up that forming the actual mould. There is an advantage also in facing the moulds with plumbago, or very finely ground charcoal. This prevents the formation of a siliceous skin on the casting, although the carbonaceous coating to the mould is practically a mere film. Allowed to become practically cold in such moulds, castings should be as soft as the character of the iron will permit. Cast iron is not appreciably amenable to annealing after it has cooled, but during solidification and cooling down to about 300 degs. C., the rate of cooling exerts much influence.



At a picture-house the other day a picture was shown entitled:

"As God Made It."

Immediately following the projection of the title on the screen came the flash: "Approved by the Board of Censors."

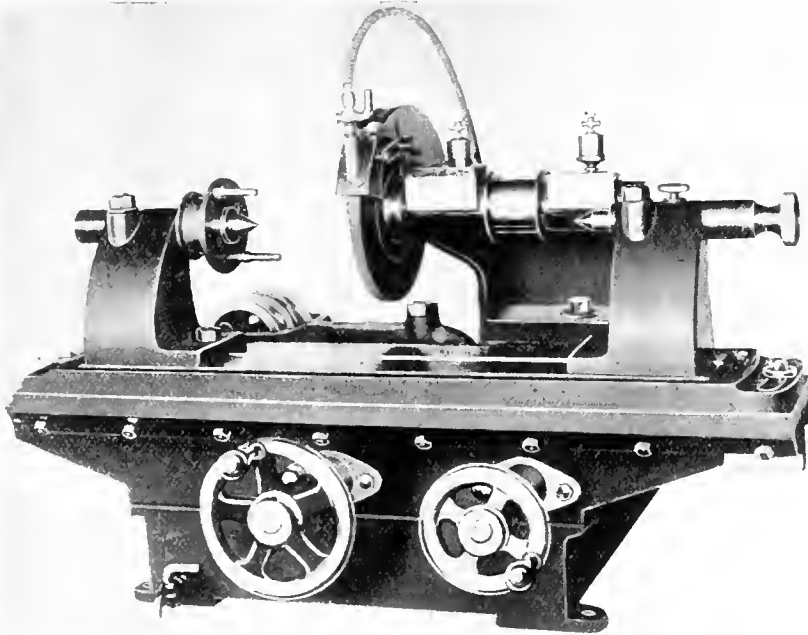

CUTTER AND TOOL GRINDER FOR BENCH OR COLUMN.

feed of 6 in., having micrometer adjustment graduated to .0005 in., which greatly facilitates the attainment of essential accuracy in tool work.

The wheel spindle is 1 in. dia. mounted in phosphor bronze bearings $3\frac{1}{2}$ and 3 in. in length, which insure a rigid drive. The driving pulley is 3 in. dia. for $1\frac{3}{4}$ in. belt, and the maximum size of wheel carried is 8 in. dia. x $\frac{3}{4}$ in. face. Work centres are each $\frac{7}{8}$ in. dia., the tailstock centre being provided with quick adjustment. Internal grinding is performed by means of a special attachment which is clamped to the wheelhead. The internal grinding spindle runs in ball bearings. The machine is regularly equipped with pump of original design, a lubricant reservoir being provided in the base. Regular equipment consists of one face plate, 9 in. dia., threaded to hollow spindle of headstock and fitted for No. 2 Morse taper; internal grinding attachment; two-speed countershaft; one 8 in. x $\frac{1}{2}$ in. emery wheel. While specially designed for bench work, the machine is furnished with or without floor stand.

This machine is marketed as Matson's Cutter and Tool Grinder, by Factory & Mill Supply Co., Boston, Mass.



TURBINE GEARING

By D. Street.

IN TURBINE reduction gears for ship propulsion the width of the gear must of necessity be very great as compared with the pitch and the diameter, and wherever this condition exists the difficulty of maintaining an even working pressure over the whole width of tooth surface is enormously increased. The unavoidable minute irregularities in the

rotation; while the torque in the pinion itself, which can never be entirely eliminated, may cause that part of the tooth-face nearest the turbine to take permanently an undue share of the duty. From these circumstances springs the liability of the turbine reduction gears to vibration, noise and unexpected breakage, and the necessity for employing gears of a larger pitch, strength, and weight than would otherwise be necessary.

The problem is, however, by no means insoluble. Macalpine was the first to tackle it seriously. His original arrangement was one in which the pinion was carried in a rocking frame which permitted it to give a little under extra pressure at either side, and so maintain an equality of pressure across the tooth-face. Later hydraulic compensating support was substituted for the mechanical support.

Excellent results have been obtained from this method of automatic self-alignment of the pinion to the wheel, but more recently the problem has been attacked from the other side by building a wheel which will adapt itself to the pinion. The gear is built up of a number of plates machined to a form which gives them the desired degree of lateral flexibility. These plates are put together, engaging solidly at the hub, and also engaging on a narrow edge at the periphery. When so built together, they form a solid cylinder, which can be spirally cut in the ordinary manner. After cutting, the edge engagements are relieved with a small dividing tool, so that each disc is operated independently, and is free to deflect laterally under the side pressure which results from its diagonal engagements with the pinion. The

The MacLean Publishing Company

LIMITED

(ESTABLISHED 1888)

JOHN BAYNE MACLEAN - - - - - President
H. T. HUNTER - - - - - Vice-President
H. V. TYRRELL - - - - - General Manager

PUBLISHERS OF

CANADIAN MACHINERY AND MANUFACTURING NEWS

A weekly newspaper devoted to the machinery and manufacturing interests.

PETER BAIN, M.E., Editor. B. G. NEWTON, Manager.

Associate Editors

A. G. WEBSTER J. M. WILSON J. H. RODGERS

Office of Publication, 143-153 University Avenue, Toronto, Ont.

Vol. XVII. MAY 17, 1917 No 20.

CANADIAN STEEL CORPORATION ACTIVITY

THE decision of the Canadian Steel Corporation—United States Steel Corporation subsidiary, to go ahead with a nine million dollar section of the big plant projected and provided for at Ojibway, Ont., is of more than passing interest, and may be taken as not only justifiable from an emergency viewpoint, but as an indication that post-war opportunities, arising in and to be developed abroad from this Dominion, are of the most assured and substantial nature. All of our steel mills are booked far ahead with orders for munitions steel, even to a degree involving further extension of plant and increasing existing equipment. The rolling of steel rails for which two of our mills are fully equipped is a matter of considerable urgency, and equally so is that of the rolling of ship plates and shapes to meet the needs of our shipyards. The erection and equipping of the plant at Ojibway is certain to be rushed to completion with the least possible delay, the powerful and progressive nature of the interests behind it giving this assurance.



BEST SHIP SIZE TO MEET THE EMERGENCY

WHILE possibly of less moment so far as Canada's shipbuilding programme is concerned, due to the necessarily inland location of what constitutes the majority of her steel shipbuilding plants, it is worthy of note that expert opinion is not at all unanimous as to the size of merchant vessel to be constructed that will most effectually offset enemy submarine activities. Our lake shipyards are restricted to size in their vessel product for ocean service by our canal capacity seawards, but not so the great majority of British and American establishments. Granting meantime, however, that bigger ships than our lake plants dare build will best meet the need, and an exceptionally strong series of arguments appears to justify them, there is, of course, no reason why full advantage should not be taken of our every available capacity, for it will be of the greatest possible value in the present urgency and materially aid in the permanent re-establishment of our Empire merchant marine.

Big Ship Construction Plant Locations

A few weeks ago, our leading illustrated descriptive article—"Intensifying Our Shipbuilding and Marine Engineering Industries,"—urged more attention being given to the establishment of new shipyards from Montreal eastwards, and indicated Sydney and Halifax, Nova Scotia, and St. John, New Brunswick, as desirable locations. The opinion then expressed was that we have as many shipbuilding and ship-repairing plants on our lake shores as there is business for in normal times, although in this crucial period it can truthfully be said that their effort is no mean one. Ocean-going freighters, small, medium and large, cannot come amiss at this juncture, and cannot be pressed into service one moment too soon. However, there seems to be a disposition to lay overmuch stress on the value of the latter in plants whose equipment and other constructional facilities are capable of turning out vessels of three or four times the tonnage of the others. To this phase of the present shipbuilding propaganda considerable opposition has been aroused, and as already stated the attitude adopted has much to commend it, if not to wholly justify it.

A committee of shipping experts in Manchester, England, in a report recently made public, have the following to say on the preference being given small ship construction as against that of large ones where the facilities and equipment are available:—

"The policy of small ship construction can only have a most disastrous effect on the nation, the man-power required by the army, and our chances of victory. The Germans claim to be sinking 9,000,000 tons a year and hope to sink still more. Allowing losses by mines and natural causes to balance any exaggeration of the German claims, and assuming that we build one-half the lost tonnage (about two and a half times our pre-war output), and other countries the balance (over five times their pre-war output), we have increased last year's output by about four million tons, equivalent to 1,600,000 tons of cargo capacity per year.

Comparisons in Size and Cost.

"Comparing ships of 2,000 tons and 16,000 tons displacement, carrying 650 and 8,675 tons of cargo respectively, and taking the North Atlantic passage as a basis, we should require to build each year 2,460 of the smaller ships, but only 185 of the larger. The smaller ships would cost \$555,000,000, and the larger only \$230,000,000. The small ships would use 1,550,000 tons of steel and 575,000 tons of timber, and would consume 6,750,000 tons of coal on the outward voyages per year. The larger ships would absorb 1,030,000 tons of steel and 382,000 tons of timber, and consume only 1,560,000 tons of coal.

Men and Material

"The number of men employed in building the ships, including making and handling steel and other materials, would be 635,000 for the smaller ships and 285,000 for the larger. The coal consumed would account for 45,000 men for the small ships as against 10,500 for the large. Thus the larger ships would release about 380,000 persons for other national service. Moreover, the larger ships would require 60,000 fewer mariners. Again, the percentage of loss, both in number of ships and in cargo-carrying capacity, will be greater with small ships than large, and the former will produce greater congestion in ports.

"The policy of the small ships, therefore, is all wrong. All our shipbuilding energies should be directed towards building the largest ships our various yards can efficiently handle."

INDUSTRIAL NOTABILITIES

LOUIS MARCEL LYMBURNER, president and general manager, Lymburner, Ltd., Engineers, Brass Founders & Munition Manufacturers, Berri and Commissioners Streets, Montreal, was born at St. Henry (now Montreal), September 7, 1871, son of Marcel E. Lymburner, ex-Mayor of St. Cunegonde, and Mathilde Guyard de Fleurie. His ancestors were of Scottish origin, having come to Canada with a Scottish regiment in 1793; his great grandfather, Adam Lymburner, was one of the promoters of the Lachine Canal.

After receiving his education at Belmont School, Montreal, Mr. Lymburner commenced his apprenticeship with his father, who, for over forty years, carried on business as brass founder, finisher and plater. Here he worked through every department of the business, remaining till 1893. For the next two years he was employed by the firm of Robert Mitchell & Co., after which he returned to his father's business to succeed him,



LOUIS MARCEL LYMBURNER.

and has been engaged in this business continuously for 21 years. In 1907 the business was incorporated under the present name, with Mr. Lymburner president and general manager.

The Company's plant is equipped with the most modern machinery for engineering and machine work, brass moulding, finishing and plating. A special line of product is fire station equipment, the Company holding numerous patents covering such features as harness release, horse-loosening and door-opening devices specially designed for time-saving.

Mr. Lymburner married Marie Louise Dextras dit Bezier, daughter of Frederic Dextras dit Bezier, Montreal, November 17, 1891; the family consists of three sons and eight daughters. His principal recreation is motoring.

He is a member Montreal Board of Trade and Chambre de Commerce du District de Montréal. In politics he is Independent, and in religion, Roman Catholic. His address is 721 Northmount Ave., Montreal, Quebec.

Photo Courtesy International Press.

SELECTED MARKET QUOTATIONS

Being a record of prices current on raw and finished material entering into the manufacture of mechanical and general engineering products.

PIG IRON.

Grey forge, Pittsburgh.....	\$40 95
Lake Superior, charcoal, Chi- cago	46 75
Standard low phos., Philadel- phia	75 00
Bessemer, Pittsburgh	44 95
Basic, Valley furnace	42 00
Montreal Toronto	
Middlesboro, No. 3	
Cleveland, No. 3	
Clarence, No. 3	
Hamilton	
Victoria	50 00

FINISHED IRON AND STEEL.

Per lb. to Large Buyers Cents	
Iron bars, base, Toronto...	4 75
Steel bars, base, Toronto ..	5 00
Steel bars, 2 in. to 4 in. base	6 00
Steel bars, 4 in. and larger base	7 00
iron bars, base, Montreal ..	4 75
Steel bars, base, Montreal ..	5 00
Reinforcing bars, base	5 10
Bessemer rails, heavy, at mill	38 00
Steel bars, Pittsburgh	4 00
Tank plates, Pittsburgh	6 50
Beams and angles, Pitts- burgh	4 00
Steel hoops, Pittsburgh	4 25
F.O.B., Toronto Warehouse.	
Steel bars, base	5 00
Small shapes	5 25
F.O.B. Chicago Warehouse	
Steel bars	4 25
Bars, 2 in. and up	4 40
Structural shapes	4 75
Plates	6 00

FREIGHT RATES.

Pittsburgh to Following Points			
	Per 100 lbs.		
	C.L.	L.C.L.	
Montreal	23.1	31.5	
St. John, N.B.	35.1	45.5	
Hullfax	35.1	45.5	
Toronto	18.9	22.1	
Guelph	18.9	22.1	
London	18.9	22.1	
Windsor	18.9	22.1	
Winnipeg	64.9	85.1	

METALS.

Montreal Toronto		
Lake copper	\$38 50	\$37 00
Electro copper	38 50	37 00
Castings, copper	37 50	35 00
Tin	63 50	68 00
Spelter	13 50	12 00
Lead	13 00	13 25
Antimony	27 00	30 00
Aluminum	70 00	68 00

Prices per 100 lbs.

PLATES.

Montreal Toronto		
Plates, 1/4 to 1/2	\$9 00	\$8 00
Heads	9 30	8 10
Tank plates, 3-16 in. ..	9 10	8 10

WROUGHT PIPE.

In effect May 3, 1917.			
Per 100 feet--	Black	Galv.	
Buttweld.			
1/8 in.	\$ 4 50	\$ 6 00	
1/4 in.	4 72	6 76	
3/8 in.	4 72	6 76	
1/2 in.	6 04	7 61	
3/4 in.	7 59	9 72	
1 in.	11 22	14 37	
1 1/4 in.	15 18	19 44	
1 1/2 in.	18 15	23 24	
2 in.	21 42	31 27	
2 1/2 in.	39 20	50 02	
3 in.	51 26	65 41	
3 1/2 in.	63 48	80 50	
4 in.	75 21	95 38	
Lapweld.			
2 in.	27 38	33 86	
2 1/2 in.	40 95	51 19	

3 in.	53 55	66 94
3 1/2 in.	65 32	83 26
4 in.	77 39	98 65
4 1/2 in.	90 17	114 90
5 in.	105 10	133 90
6 in.	136 30	173 80
7 in.	178 50	224 90
8 in.	187 50	236 30
9 in.	216 00	272 20
10 in.	258 80	326 00
10 1/2 in.	240 00	302 40
10 3/4 in.	309 00	389 30

Prices—Ontario, Quebec and Maritime Provinces.

WROUGHT NIPPLES.

1" and under, 50%.	
1 1/2" and larger, 45%.	
4" and under, running thread.	
Standard couplings, 4" and under.	
4 1/2" and larger, 20%.	

OLD MATERIAL.

Dealers' Buying Prices.			
Montreal Toronto			
Copper, light	\$21 00	\$20 00	
Copper, crucible	25 50	25 00	
Copper, heavy	25 50	24 50	
Copper wire	25 50	24 50	
No. 1 machine com- position	21 50	20 00	
New brass clippings	18 00	17 00	
No. 1 brass turnings	16 00	16 00	
Heavy melting steel	19 00	17 00	
Steel turnings	8 00	8 00	
Shell turnings	12 00	12 00	
Boiler plate	19 00	10 50	
Axles, wrought iron	22 00	24 00	
Rails	19 00	18 00	
No. 1 machine cast irons	22 00	22 00	
Malleable scrap	17 00	16 00	
Pipe, wrought	14 00	9 00	
Scrap zinc	8 00	9 50	
Tea lead	7 50	7 00	
Scrap zinc	9 00	9 50	
Aluminum	32 00	35 00	

BOLTS, NUTS AND SCREWS.

Per Cent.		
Coach and lag screws		30
Stove bolts		35
Plate washers		10
Machine bolts, 7-16 and over		10
Machine bolts, 3/4 and less.		20
Blank bolts		10
Bolt ends		10
Machine screws, fl. and rd. hd., steel		27 1/2
Machine screws, o. and fil. hd., steel		10
Machine screws, fl. and rd. hd., brass		add 20
Machine screws, o. and fil. hd., brass		add 25
Nuts, square, up to 1 in., net list.		
Nuts, hex., up to 1 in., net list.		
Copper rivets and burrs. list plus		30
Burrs only list plus		50
Iron rivets and burrs		17 1/2
Boiler rivets, base 3/4-in. and larger		\$6.65
Structural rivets, as above.		6.55
Wood screws, flat, bright.		.72 1/2
Wood screws, O. & R., bright67 1/2
Wood screws, flat, brass.		.37 1/2
Wood screws, O. & R., brass32 1/2
Wood screws, flat, bronze.		.27 1/2
Wood screws, O. & R., bronze25

MILLED PRODUCTS.

Per cent.	
Set screws	35
Sq. & Hex. Head Cap Screws	30
Rd. & Fil Head Cap Screws	10
Flat 3/8 But. Hd. Cap Screws plus	10
Fin. & Semi-fin. nuts up to 1 in.	25
Fin. and semi-fin. nuts, over 1 in., up to 1 1/2 in.	30
Fin. and semi-fin. nuts, over 1 1/2 in., up to 2 in.	10
Studs	20
Taper pins	40
Coupling bolts, plus	10
Planer head bolts, without fillet	10
Planer head bolts, with fillet	10 and 10
Planer head bolt nuts, same as finished nuts.	
Planer bolt washers	net
Hollow set screws	list plus 20
Collar screws	list plus 30, 10
Thumb screws	20
Thumb nuts	65
Patc bolts	add 40, 10
Cold pressed nuts to 1 1/2 in.	add \$4.50
Cold pressed nuts over 1 1/2 in.	add \$7.00

BILLETS.

Per gross ton	
Bessemer billets	\$ 80 00
Open-hearth billets	80 00
O.H. sheet bars	80 00
Forging billets	105 00
Wire rods	85 00
F.o.b. Pittsburgh.	

NAILS AND SPIKES.

Wire nails	5 00	4 95
Cut nails	5 00	5 00
Miscellaneous wire nails ..		60%
Pressed spikes, 3/4 diam., 100 lbs.		5 30

MISCELLANEOUS.

Solder, strictly	0 36
Solder, guaranteed	0 39
Babbitt metals	14 to 60
Soldering coppers, lb.	0 53
Putty, 100-lb. drums	4 00
White lead, pure, ewt.	16 03
Red dry lead, 100-lb. kegs, per cwt.	13 87
Glue, English	0 38
Tarred slaters' paper, roll	0 95
Gasoline, per gal., bulk ..	0 31 1/4
Benzine, per gal., bulk ..	0 30 1/2
Pure turpentine, single hbbs., gal.	0 60
Linseed oil, raw, single, hbbs.	1 40
Linseed oil, boiled, single hbbs.	1 43
Plaster of Paris, per bbl. ..	2 50
Plumbers' oakum, per cwt. ..	9 00
Packing, square braided ..	0 27
Packing, No. 1 Italian	0 32
Packing, No. 2 Italian	0 25
Lead wool, per lb.	0 15
Pure Manila rope	0 31 1/2
Transmission rope, Manila ..	0 37 1/2
Drilling cables, Manila	0 32 1/2

POLISHED DRILL ROD.

Discount off list, Montreal and Toronto	25%
--	-----

CARBON DRILLS AND REAMERS.

Per Cent.	
S.S. drills, wire sizes up to 52	40
S.S. drills, wire sizes, No. 53 to 80	25
Standard drills to 1 1/2 in. ..	40
Standard drills, over 1 1/2 in. ..	15
3-fluted drills, plus	10
Jobbers' and letter sizes	40
Bit stock	40
Ratchet drills	15
S.S. drills for wood	40
Wood boring brace drills ..	25
Electricians' bits	30
Sockets	30

Sleeves	40
Taper pin reamers	20
Drills and countersinks	list plus 30
Bridge reamers	45
Centre reamers	10
Chucking reamers	10
Hand reamers	15

COLD ROLLED SHAFTING.

At mill	list plus 40%
At warehouse	list plus 50%

Discounts off new list. Ware-
house price at Montreal and
Toronto.

IRON PIPE FITTINGS.

Canadian malleable, A, add 10%; B and C, 10%; cast iron, 35%; standard bushings, 50%; beaders, 60; flanged unions, 40; malleable bushings, 50; nipples, 55; malleable lipped unions, 50.

SHEETS.

Montreal Toronto			
Sheets, Black, No. 28	\$7 75	\$7 85	
Sheets, Black, No. 10	7 50	7 90	
Canada plates, dull, 52 sheets	7 00	7 00	
Canada plates, all bright	8 00	8 00	
Apollo brand, 10 1/2 oz. galvanized	7 25	7 25	
Queen's Head, 28 B. W.G.	7 75	7 75	
Fleur-de-Lis, 28 B.W. G.	7 45	7 35	
Gorbals' Best, No. 28	8 25	7 50	
Colborne Crown, No. 28	8 00	6 75	
Premier, No. 28 U.S.	8 30	8 70	
Premier, 10 1/4 oz.	8 60	9 00	

PROOF COIL CHAIN.

B	
1 1/2 in.	\$9 75
5-16 in.	9 40
3/4 in.	8 65
7-16 in.	7 45
1/2 in.	7 25
9-16 in.	7 25
3/8 in.	7 15
5/16 in.	7 05
1 inel.	6 90
Extra for B.B. Chain	1 20
Extra for B.B.B. Chain	1 80

ELECTRIC WELD COIL CHAIN B.B.

1 1/2 in.	\$15 50
3-16 in.	11 70
1/2 in.	8 40
5-16 in.	7 40
3/4 in.	6 35
7-16 in.	6 35
1/2 in.	6 35
5/8 in.	6 35
3/4 in.	6 35

Prices per 100 lbs.

FILES AND RASPS.

Per Cent.	
Great Western, American	55
Kearney & Foot, Arcade	55
J. Barton Smith, Eagle	55
McClelland, Globe	55
Whitman & Barnes	55
Black Diamond	45
Delta Files	40, 7
Nicholson	45
Globe	55
Vulcan	55
Disston	55

COAL AND COKE.

Solvay Foundry Coke	
Cornellville Foundry Coke ..	
Yough Steam Lump Coal	
Pittsburgh Steam Lump Coal ..	
Best Slack	
Net ton f.o.b. Toronto	

BOILER TUBES.			TAPES.		ANODES.		SHEETS, 3½ lbs. sq.				
Size.	Seamless	Lap-welded	Chesterman Metallic, 50 ft.	\$2 00	Nickel	.50 to .54	ft.	17 00	17 00		
1 in.\$24 00	Lufkin Metallic, 603, 50 ft.	2 00	Cobalt	1.55 to 2.00	Sheets, 4 to 6 lbs.		
1¼ in. 30 00	Admiral Steel Tape, 50 ft.	2 75	Copper	.44 to .46	sq. ft.	16 50	16 50		
1½ in. 32 00	25 00	Admiral Steel Tape, 100 ft.	4 45	Tin	.49 to .56	Cut sheets, ½¢ per lb. extra				
1¾ in. 32 00	25 00	Major Jun. Steel Tape, 50 ft.	3 50	Zinc	.23 to .25	Cut sheets to size, 1¢ per lb. extra.				
2 in. 35 09	26 00	Lival Steel Tape, 50 ft.	2 75	PLATING CHEMICALS.						
2½ in. 44 00	33 00	Lival Steel Tape, 100 ft.	4 45	Acid, boracic				\$.15	
3 in. 47 00	38 00	Reliable Jun. Steel Tape, 50 ft.	3 50	Acid, hydrochloric				05	
3¼ in.	45 00	WASTE.		Acid, hydrofluoric				 14½	
2¾ in. 59 00	48 00	White		Acid, nitric				10	
4 in. 74 00	60 00	Cents per lb.		Acid, sulphuric				05	
Prices per 100 feet, Montreal and Toronto.			XXX Extra		20	Ammonia, aqua				08
OILS AND COMPOUNDS.			Peerless		20	Ammonium carbonate				15
Castor oil, per lb. 27		Grand		19	Ammonium chloride				11
Royalite, per gal., bulk 16		Superior		19	Ammonium hydrosulphuret				40
Palacine 19		N L C R		18	Ammonium sulphate				07
Machine oil, per gal. 26½		Atlas		18	Arsenic, white				12
Black oil, per gal. 13		N Empire		18	Copper, carbonate, anhy.				35
Cylinder oil, Capital 45½		Ideal		17	Copper, sulphate				17
Cylinder oil, Aeme 36½		X press		16	Cobalt sulphate				70
Standard cutting compound, per lb. 6 15		COLORED.			Iron perchloride				20
Lard oil, per gal. 1 45		Lion		14½	Lead acetate				16
Union thread cutting oil antiseptic 68		Standard		13	Nickel ammonium sulphate				12
Aeme cutting oil, antiseptic 37½		No. 1		13	Nickel carbonate				25
Imperial quenching oil 39½		Popular		11¾	Nickel sulphate				15
Petroleum fuel oil 11¼		Keen		10½	Potassium carbonate				75
BELTING—NO. 1 OAK TANNED.			WOOL PACKING.			Potassium sulphide (substitute)				20
Extra heavy, single and double 30-5%		Arrow		25	Silver chloride (per oz.)				65
Standard 40%		Axle		20	Silver nitrate (per oz.)				55
Cut leather lacing, No.1 1 50		Anvil		15	Sodium bisulphite				10
Leather in sides 1 35		Anchor		11	Sodium carbonate crystals				05
			WASHED WIPERS.			Sodium cyanide, 127-130%				41
			Select White		12	Sodium hydrate				04
			Mixed colored		10	Sodium hyposulphite, per 100 lbs.				 5.00
			Dark colored		09	Sodium phosphate				14
			This list subject to trade count for quantity.			Tin chloride				60
			RUBBER BELTING.			Zinc chloride				60
			Standard		40%	Zinc sulphate				09
			Best grades		20%	Prices Per Lb. Unless Otherwise Stated.					

The General Market Condition and Tendency

STEEL prices are still advancing steadily, being helped in their upward movement by conditions in the States. As indications point to the American Government paying nearer current prices for steel than was originally fixed, it is likely that the upward tendency will be more pronounced. Indications also point to the Government's requirements being very heavy, which will result in a greater shortage of steel for other purposes, adversely affecting the private consumer. Canadian manufacturing interests will also be affected as they depend at the present time to a large extent on American steel, domestic mills being engaged more or less on war business. Prices of plates have again advanced and the end is not in sight. The scarcity of plate is a serious matter, as it is delaying the construction of ships. Price at present is no object as long as plates can be obtained. Blue annealed sheets have also advanced, while higher prices on black sheets and possibly tubes are looked for in the near future. The scrap metal market is quiet at unchanged prices. Prices of steel and cast scrap are firm, but copper and brass continue weak. In the non-ferrous metals tin has made a sharp advance, due to shortage of supplies and possibility of the submarine campaign causing losses of metal. Lead is also higher on account of a scarcity and expected bigger demand in the near future. The machine tool business is quiet, but prospects are improving. The demand is assuming a more normal character. Limited supplies of Victoria foundry pig-iron are available at \$50, but the market is very firm and further advances are looked for.

Montreal, Que., May 11, 1917.—Industrial interests are closely watching developments which are gradually transforming conditions in the United States and which will eventually affect the general

situation in this country. The recent war measure entailing increased taxation in that country, will undoubtedly result in great changes, the extent of which it is impossible to foretell at this

time. Canada will naturally be affected by any changes that may take place across the line, as conditions here are governed to a great extent by those prevailing in the United States. The army and navy program of the American Government may curtail the shipment of considerable material intended for industries in this country, but it is understood that every facility will be provided to prevent any possibility in the restriction in the output of munitions or other war necessities, both in this country and the States. The general activity of present industrial developments is gradually undergoing change for while little reduction has been noticed in the production of the smaller types of munitions, there is a noticeable falling off in the manufacture and prospects for further business in the larger sizes of shells. This is however, is being somewhat offset by the appreciable increase in the activity displayed in ship-building circles, this industry promising to attain the same proportions as that of the shell industry, and one that may prove more permanent.

Pig Iron

Further advances are still a feature of the pig iron situation and the market is very strong with the tendency ever upward. The Canadian producers are virtually out of the market as very little metal is available at any price. The advances noted on the American market range from \$1 to \$5 per ton; the quotation of composite pig iron being

\$41.935 per ton, an advance on the week of over \$1.25 per ton.

Steel

The situation throughout the steel industry is rapidly approaching a point where it will be practically impossible for any but war interests to continue producing on anything like the scale hitherto existing. This abnormal condition is being created through the excessively high cost of all raw materials and the necessity of the different governments to curtail or eventually stop production for all domestic requirements other than those essential to the prosecution of the war. Even should the opportunity be available for domestic interests to secure material for their future requirements, the prohibitive expenditure entailed in the purchase of the necessary product makes it imperative that operations be curtailed or possibly cancelled until a more favorable period. The demand for all grades of steel seems to have increased and this is largely due to the fact that many producers are virtually out of their respective markets, conditions rapidly becoming such that certain grades of steel must be produced in larger quantities and it is up to the different producers to get this material out irrespective of what their particular plant has hitherto done. In this respect, the American government has apparently put it up to the steel industries to produce the steel, or other means will necessarily have to be found to meet the requirements of the situation. Further advances in basic iron may shortly be reflected in certain grades of steel as the conditions prevalent in pig iron govern, to a large extent, the prices existing in the different steel circles.

Marked scarcity of sheet bars and inability of mills to obtain supplies has resulted in a further advance on the New York market, an advance of \$5 per ton bringing the current quotation up to \$90 per ton. The price on iron bars, New York, has been advanced during the week from \$3.419c to \$4.169c, this being \$15 per ton above that of last week. The inability to obtain sheets keeps the market in a very strong position but local dealers report a practically closed market on these lines. The plate mills are making every effort to supply the requirements of the trade but their filled up condition does not permit them to take on any further business, and in addition there is always the possibility that existing orders may have to be set back to make room for government orders. Small mills which can handle material can obtain almost any price they ask. Local dealers have again revised their quotations on plates, the advance being quite stiff, and an indication of what early future conditions may be. Plates $\frac{1}{4}$ to $\frac{1}{2}$ inch are now quoted at \$9 per hundred; heads \$9.30 to \$9.65; and 3-16 inch tank plates \$9.10; these prices being approximately $1\frac{1}{2}$ cent per lb. higher than those of a week ago. Further price adjustments, on other

grades, are expected in the near future.

Metals

With the exception of tin and antimony, the general metal situation is very firm. The market is still dominated by prospective American developments. Copper has apparently taken on strength but prices do not conform with visible conditions. Tin has made a considerable jump, due to several conditions that combine to excite the market. Spelter is held firm by the high cost of production but the market is quiet. Lead is firm and steady. Antimony is stronger after a period of weakness. Aluminum is firmer locally but slightly weaker abroad.

Copper.—Following the advance early in the week the market has again become quiet but the firmness remains. Large consumers are reluctant to buy at what seems to them to be inflated prices, until further developments give a more reliable tone to the actual situation. At the same time there appears to be a certain disposition on the part of buyers to close business for their future requirements; this feature might indicate that an early buying movement on a fairly large scale would be a factor in early trade development. Large producers are well sold for the next several months and reports seem to favor extra heavy buying to cover last half requirements. London is firm while New York is quoting the nominal figures of 33c for lake and electro, and 30 $\frac{1}{4}$ c for castings; these prices showing advances of $1\frac{1}{2}$ c, one cent, and $\frac{3}{4}$ c respectively. The situation here is a little stronger, having advanced $\frac{1}{2}$ c during the week, the quotation being 38 $\frac{1}{2}$ c for lake and electro and 37 $\frac{1}{2}$ c for castings.

Tin.—Conflicting reports are current as to the actual cause for the recent strong position of tin; rumors of loss in transport together with the contemplated tariff changes imposed by the United States government are the leading factors for the sharp advance recorded during the past week. The increase in tariff will undoubtedly mean that higher prices will prevail in pig tin and tin products. This metal is at present in great demand owing to the heavy requirements of the governments and domestic manufacturers in preparing for the canning season, and the inevitable need for large supplies of canned foods to carry the country through the coming period of uncertainty. A feature of the present situation is the exceptionally strong London market where the advance of the week has been £12 per ton. The New York market is up 5 $\frac{1}{2}$ c per lb., the quotation being 64 $\frac{1}{4}$ c per lb. Local dealers are quoting 63 $\frac{1}{2}$ c, this being an advance of 3c per lb.

Spelter.—The market in spelter is very quiet but firmness prevails; although the situation is unsettled, and buyers and producers are apparently awaiting developments, the undertone is strengthened by the fact that the cost of production is such that much lower prices than those prevailing would en-

tail loss to the smelters. The brass interests are not active buyers and the demand in this direction is comparatively light. Firmness prevails on a quiet market, both in London and New York, the quotation on the latter being 9 $\frac{1}{2}$ c per lb.

Lead.—The market in lead shows little change although increased irregularity is evident in the general tone of the situation; the strength however, is well maintained with slightly higher prices prevailing on the open market in the States, the nominal quotation during the week having advanced $\frac{1}{2}$ c in St. Louis, making the price of 10 $\frac{1}{2}$ c general for independent quotations. Dealers here report a steady and firm market.

Antimony.—Reports on conditions in the antimony market are very conflicting. After the recent decline of over 10c per lb. the situation has apparently steadied and is actually showing strength but the reasons for so doing are varied and also uncertain. No increased activity has been shown on the part of the consumers but the offerings of metal seem to have fallen off. While the current quotation in New York is nominally 26c and one cent lower than the corresponding period of last week, this price is still several cents stronger than a few days ago. Firmness prevails on the local market.

Machine Tools and Supplies

No change is noted in the machine tool situation and if anything the market is quieter than last week. The market for equipment for large shells is practically stagnant and it is anticipated that business in the 8 and 9.2 in. shells will be almost at a standstill by the first of August, with the possible exception of a few of the larger manufacturers. Fair business is still being carried on in machinery for small shells but general activity in munitions tools is gradually showing a falling off. General domestic trade is very encouraging, considering the high cost of equipment; the demand for wood working machinery for ship building purposes, promises well for the coming months, but this activity is not much pronounced locally owing to the ship yards in this locality being fairly well equipped for present requirements. However, developments in the Maritime Provinces are of a nature that may demand greater supplies of ship building equipment. Prices on all kinds of machine tools and supplies continue firm with an upward tendency, due to the continual advances in the cost of raw and semi-finished materials.

Scrap

The general tone of the scrap situation is very unsettled, the market being very erratic and subject to sharp and uncertain fluctuations following the developments in political circles. The effect these conditions are having on the market is to create a situation where quotations are only nominal, and liable to change at any time. The demand for all grades of scrap is good, more particularly composition scrap, and the prices on tin and kindred scrap have ad-

vanced following the strength of the tin situation. The local market is also affected by the general conditions, with the week's quotations showing strength in iron and steel scraps and slight weakness in old metals. Old coppers have declined one cent, the prices quoted being 21c for light and 25½c for heavy and crucible. Machine composition on a similar decline is quoted at 21½c. Old boiler plate, on a ½c rise, is quoted at 19c per lb. Rails are now 19c, this being an advance on the week of 2c per lb. Machine cast iron is up one cent., the price asked being 22c per lb.; while malleable scrap at 17c is two cents stronger than last week. Wrought iron pipe has advanced 1½ cent, the current quotation being 14c per lb. The price of scran zinc shows a drop of one cent, the price asked being 8c per lb. Old and scrap aluminum have declined 4c on the week, the present quotation being 32c per lb.

Toronto, Ont., May 15.—Industrial expansion in this city and district is proceeding in a most gratifying manner. In the Ashbridge's Bay the new steel plant is rapidly approaching completion, while in the vicinity it is proposed to establish a shipbuilding plant. The aeroplane factory now under construction will be in operation in a few months, while an extensive plant nearby at Camp Borden will soon be completed. Although it is unlikely that more orders for 9.2 in. and 8-in. shells will be given out, it is understood that there will be no falling off in contracts for smaller calibre shells in the meantime.

Steel

A report is again current that work on the new Canadian Steel Corporation plant at Ojibway, Ont., will be proceeded with shortly. It is understood that a rod mill will be installed while bars and small shapes will also likely be among the first products manufactured. The demand for steel is as insistent as ever and shows no indication of diminishing. The most disquieting feature at the present time is the difficulty in obtaining steel for manufacturing purposes and for buildings. The Canadian steel companies are engaged upon the production of steel almost entirely for munitions and other war purposes, leaving the private consumer largely dependent upon the American mills for the required materials. Developments in the States are making it increasingly difficult for the private or manufacturing consumer to get steel, as the American Government requirements are assuming large proportions. Government buying is assuming a more tangible form and indications are that later purchases will be at nearer to market prices than the figures originally fixed. This will tend towards more settled conditions but will at the same time have a tendency to stiffen prices and help in the general upward movement.

The expected advance in plates has materialized, the local price being now 8c for ¼-in. to ½-in. and 8.10c for heads and tank plates. Much higher prices may be

looked for as the demand is extraordinary and will continue to be so for many months yet. The fact that 11c mill was recently paid on ship plates for delivery during the first quarter of 1918 is a clear indication of what may be expected. The demand for ship plates is so urgent that it is entirely a question of getting the material, the price being practically no consideration. The situation is such that there are really no set prices on plates, sales being governed almost entirely by the deliveries wanted, tonnage and former relations existing between the buyer and the mill.

Prices of blue annealed sheets No. 10-16 gauge have advanced, No. 10 being now quoted at \$7.90. Higher prices on black sheets are expected in the near future. The new demand is abnormally heavy and very high prices are being paid for black and galvanized sheets for fairly prompt shipments. Sheet bars continue to advance and a market price of \$100 may be expected. This figure has already been reached on some special business for quick shipment.

The U.S. Steel Corporation unfilled ton-

**CANADIAN GOVERNMENT
PURCHASING COMMISSION**

The following gentlemen constitute the Commission appointed to make all purchases under the Dominion \$100,000,000 war appropriation:—George F. Galt, Winnipeg; Hormidas Laporte, Montreal; A. E. Kemp, Toronto. Thomas Hilliard is secretary, and the Commission headquarters are at Ottawa.

nage on April 30 amounted to 12,183,083 tons as against 11,711,644 on March 31st. This is a direct indication of the position of the steel market in the States. The mills are overcrowded with work of all kinds and with exceptionally heavy government orders in sight, the prospect of meeting the needs of the private consumer is not bright. Government work is being given preference, which is probably the main reason for the accumulation of business with the Steel Corporation and independent concerns.

Pig Iron

A quotation of \$50 a ton has been issued on "Victoria" pig iron, but available supplies are somewhat limited. Nearby pig iron is growing scarcer. Most furnaces are unwilling to accept orders even for small lots which require prompt or near prompt delivery unless the buyer is an old customer. Price in a majority of cases is less to be considered than the question of getting iron at all and never before have deliveries been contracted for so far ahead. Prices are still advancing. Grey forge Pittsburgh \$40.95, Basic Valley, \$42, and Bessemer Pittsburgh, \$44.95.

Scrap

With the exception of some little activity in cast scrap and steel scrap the market on the whole is quiet. Prices are generally maintained at current quotations.

Machine Tools

A gradual readjustment seems to be taking place in the machine tool business. Very little is heard of munitions these days, although some machine tools are occasionally being purchased for shell or fuse plants. More attention is now being paid to other prospective spheres of action. Shipbuilding is perhaps offering the best chance of business for heavy equipment, although as old established plants are being largely utilized for the shipbuilding campaign, this lessens demand for machinery. Specifications are out for the proposed shipyard on Ashbridge's Bay to be backed by the Imperial Munitions Board. The plans which are only partially completed call for a machine shop plate shop and blacksmith's shop, etc. Some new equipment will likely be required for the shipbuilding plant at Welland. The Canadian Aeroplanes, Ltd., have not purchased all the machinery for their new factory being built in Toronto, while the Semet-Solway Process Co. have prepared plans for a large plant at Amherstburg, Ont.

Supplies

Business continues active at firm prices. Lead sheets have advanced 1c per pound in line with all lead products. Linseed oil is very strong again and prices are advancing due to the high cost of flax seed. The demand for machine shop supplies is of a general order, particularly for belting drills, reamers, taps and dies, files, pullies, etc.

Metals

The metal markets are stronger this week, the feature being a sharp advance in tin, while lead is also higher. The improvement in the situation is due largely to a clearer indication of the American Government's policy in regard to its purchases of metals, and prices to be paid. The advance in tin due to the low visible supply and fear of cargoes being lost. Lead is higher on account of scarcity of supply and expectation of Government requirements, which it is presumed will be heavy. The copper market is firmer, but quotations are unchanged in the meantime. Spelter, antimony and aluminum are unchanged. Solders have advanced.

Copper.—The market is firmer but prices are unchanged and nominal. The indications of a further decline in the price of copper which were prominent a week or two ago have disappeared altogether and a recovery to the former high level looks likely. Producers state that consumption is in excess of production and that the copper requirements of the world for the last half of this year will be materially larger than they have been during the first six months. Local prices firm and unchanged. Lake and electrolytic 38c and casting 37c per pound.

Tin.—Prices continue to climb upward both in London and New York. The reason for this extraordinary advance is traceable to a low visible supply and also increasing risk of shipments. The market is inclined to be excited over the situation and prices may go still higher. Tin has advanced 9c locally and is now quoted at 68c per pound.

Spelter.—It is reported that the zinc

Enlarged Canadian Trade Intelligence Service

Under the arrangement made by the Minister of Trade and Commerce with Sir Edward Grey in July, 1912, the Department of Trade and Commerce, Ottawa, is able to present the following list of the more important British Consulates whose officers have been instructed by the Foreign Office to answer inquiries from and give information to Canadians who wish to consult them in reference to trade matters.

BRAZIL—Bahia, British Consul. Rio de Janeiro, British Consul General.	NETHERLANDS—Amsterdam, British Consul.
CHILE — Valparaiso, British Consul General.	PANAMA—Colon, British Consul. Panama, British Vice-Consul.
COLOMBIA — Bogota, British Consul General.	PERU—Lima, British Vice-Consul.
ECUADOR—Quito, British Consul General. Guayaquil, British Consul.	PORTUGAL—Lisbon, British Consul.
EGYPT — Alexandria, British Consul General.	RUSSIA—Moscow, British Consul General. Petrograd, British Consul. Vladivostok, British Consul. Odessa, British Consul General.
FRANCE—Havre, British Consul General. Marseilles, British Consul General.	SPAIN—Barcelona, British Consul General. Madrid, British Consul.
INDIA—Calcutta, Director General of Commercial Intelligence.	SWEDEN—Stockholm, British Consul.
ITALY—Genoa, British Consul General. Milan, British Consul.	SWITZERLAND—Geneva, British Consul.
MEXICO—Mexico, British Consul General.	URUGUAY—Monte Video, British Vice-Consul.
	VENEZUELA — Caracas, British Vice-Consul.

Canadian Commercial Intelligence Service

The Department of Trade and Commerce invites correspondence from Canadian exporters or importers upon all trade matters. Canadian Trade Commissioners and Commercial Agents should be kept supplied with catalogues, price lists, discount rates, etc., and the names and addresses of trade representatives by Canadian exporters. Catalogues should state whether prices are at factory point, f.o.b. at port of shipment, or, which is preferable, c.i.f. at foreign port.

CANADIAN TRADE COMMISSIONERS.

ARGENTINE REPUBLIC—B. S. Webb, Acting Canadian Trade Commissioner, Reconquista, No. 46, Buenos Aires. Cable address, Canadian.
AUSTRALIA—D. H. Ross, Stock Exchange Building, Melbourne. Cable address, Canadian.
BRITISH WEST INDIES—E. H. S. Flood, Bridgetown, Barbadoes, agent also for the Bermudas and British Guiana. Cable address, Canadian.
CHINA—J. W. Ross, 13 Nanking Road, Shanghai. Cable address, Cancom.
CUBA—A. T. Quilez, Acting Canadian Trade Commissioner, Lonja del Comercio, Apartado 1290, Havana. Cable address, Cantracom.
FRANCE—Phillipe Roy, Commissioner General, 17 and 19 Boulevard des Capucines, Paris. Cable address, Stadacona.
JAPAN—E. F. Crowe, Acting Canadian Trade Commissioner, P. O. Box 109, Yokohama. Cable address, Canadian.
HOLLAND—P. H. Geleerd, Acting Canadian Trade Commissioner, Zuidblaak, 26, Rotterdam. Cable address, Watermill.
RUSSIA—C. F. Just, Canadian Government Commercial Agent, Alexandrinskaja, Plosch 9, Petrograd. L. D. Wilgress, Canadian Government Commercial Agent, Bukhgoizna Ulitsa No. 4, Omsk, Siberia.
NEWFOUNDLAND—W. B. Nicholson, Bank of Montreal Building, Water Street, St. John's. Cable address, Canadian.
NEW ZEALAND—W. A. Beddoe, Union Buildings, Customs Street, Auckland. Cable address, Canadian.
SOUTH AFRICA—W. J. Egan, Norwich Union Buildings, Cape Town. Cable address, Cantracom.
UNITED KINGDOM—Harrison Watson, Sub-division E.C. 2, 73 Basinghall Street, London, E.C., England. Cable address, Sleighbing, London. N. D. Johnston, Sun Building, Clare Street, Bristol. Cable address, Canadian. J. E. Ray, Central House, Birmingham. Cable address, Canadian. J. Forsyth Smith, 31 North John Street, Liverpool. Cable address, Cantracom. F. A. C. Rickerdike, 4 St. Ann's Square, Manchester. Cable address, Cantracom. J. Forsyth Smith, Acting Canadian Trade Commissioner, 87 Union Street, Glasgow, Scotland. Cable address, Cantracom.

CANADIAN COMMERCIAL AGENTS

AUSTRALIA—B. Millin, Royal Exchange Building, Sydney, N.S.W.
BRITISH WEST INDIES—Edgar Tripp, Port of Spain, Trinidad. Cable address, Canadian. R. H. Curry, Nassau, Bahamas.
NORWAY AND DENMARK—C. E. Soutum Grubbegd No. 4, Christiania, Norway. Cable address, Sontums.
SPAIN—J. F. Roberts, Care British Consulate General, Barcelona.

CANADIAN HIGH COMMISSIONER'S OFFICE

UNITED KINGDOM—W. L. Griffith, Secretary, 17 Victoria Street, London, S.W., England. Cable address, Dominion, London.

producers have named a price to the American Government of 11½c a pound delivered for grade A, 11c for grade B and 9c for grade C. It is understood that in accordance with this arrangement 25 million pounds have been contracted for with delivery over the next twelve months. As a result the market is firmer but dull. Local prices unchanged at 12c per lb.

Lead.—The market is dull but very firm and prices are higher locally. As the leading interests have withdrawn from the market for the time being they have left it bare of supply and consumers who must have metal for current needs have been obliged to pick up where they could. Lead has advanced ½c locally and is now quoted at 13½c per pound.

Antimony.—The market is firmer than last week but the price is unchanged and nominal. Local price 30c per pound.

Aluminum.—The market is quiet for spot metal and quotations unchanged at 68c per pound.

Solders.—Prices of solders have advanced in line with tin and lead. Guaranteed is now quoted at 39c. and strictly at 37c per pound.

Sydney, N.S., May 9.—The week has been marked by a series of increases in wages. The Royal Commission appointed to enquire into the wage question at the mines of the Dominion Coal Co., gave as its formal finding an increase to the mine workers of ten cents per day in the case of all men earning \$2.50 and under per day, plus an increase of 12½ per cent. to all workmen. The increase of 12½ per cent. in the case of the men earning \$2.50 per day and under is applied on top of the increase of ten cents per day. A recital of the increases given to the workmen of the Dominion Coal Co. since June 1, 1916, is rather impressive. At that date an increase of six per cent. was granted, followed in November by a further increase of fourteen per cent., and followed by the increase just referred to of 12½ per cent. and ten cents per day to the men under \$2.50 per day. In addition, the company are paying a 5 per cent. bonus on the earnings of all producers who work 22 days out of each working period of 24 days. In 1908, when the Shortt Conciliation Board gave the award which has formed the basis of agreements since that date, the minimum rate for day labor at the mines was \$1.38 per day. Men of this class will now receive \$2.41 per day, so that the increase during a period of less than ten years has been almost 75 per cent. Other classes of labor have not been increased quite so heavily as the unskilled day laborer, but in no case has the increase in the wages of mine workers during the past decade been much under 50 per cent.

At Springhill Mines, the Dominion Coal Co. have also made an increase, effective, as in the case of the Glace Bay mines from May 1. At Springhill, an increase of ten cents per day is given to men below \$2.50 per day, and in addition an increase of ten per cent. is given

(Continued on page 525.)

INDUSTRIAL ^A_D CONSTRUCTION NEWS

Establishment or Enlargement of Factories, Mills, Power Plants, Etc.; Construction of Railways, Bridges, Etc.; Municipal Undertakings; Mining News

ENGINEERING

Vancouver, B.C.—The Phoenix Iron Works were destroyed by fire recently.

Hamilton, Ont.—The Bowes, Jamieson Co. will move their shell plant down to the Baines Carriage Works in Hamilton East.

Kingston, Ont.—The Kingston Shipbuilding Co. has practically purchased the plant of the Kingston Foundry Co., adjoining its premises.

Toronto, Ont.—Fire on May 11 did damage, estimated at \$250,000, to the plant of the Cluff Ammunition Co., Sterling Road.

Niagara Falls, Ont.—Operations on the Chippawa-Queenston Hydro-Power canals have been started. The work will be rushed owing to the demand for additional power.

Windsor, Ont.—It is reported that the Canadian Steel Corporation will proceed with the construction of a steel plant at Ojibway. Present arrangements call for an expenditure of \$9,000,000 in the erection of buildings and installation of machinery.

Amherstburg, Ont.—The Brunner-Mond Co., a subsidiary of the Solvay Process Co., of Syracuse, N.Y., are having plans prepared for a plant to cost \$2,000,000.

Montreal, Que.—A new and important pulp and paper company has been organized in this city with a capital of one million dollars. The concern proposes to erect and operate mills on the Madeleine River, in Gaspé County, on the south shore at the mouth of the St. Lawrence River.

Chatham, Ont.—The foundry at the old Defiance Iron Works, which is now the Canadian-American Pump & Well Machinery Co., located on Lacroix Street, and which has been idle for several years, is again under operation under the management of Woods Bros., who for several years have operated the Ideal Foundry on Princess Street.

Toronto, Ont.—The shipbuilding plant which is contemplated for the Ashbridge's Bay district will be backed by the Imperial Munitions Board. The plans are already well developed, so much so that prices are being obtained on the chief equipment required for the various departments of the enterprise.

Fort William, Ont.—Mayor Murphy announces that work will be begun by June 1 on a 150-ton pulp mill on the site here adjoining the Canadian Government Railways docks. The Kaministiquia Power Co. will supply 8,500 h.p. and the city a million and a half gallons of water. As soon as the pulp mill is running a 100-ton paper mill will be erected by the company.

St. John, N.B.—In order to increase the production of the plant and improve

the quality of its output, the Nashwaak Pulp & Paper Co. has decided to enlarge the works and add new machinery thereto. Good progress has already been made on the new developments. The company manufacture what is known as bleached sulphite wood pulp, the basic material being obtained from the spruce products of their own forests.

Montreal, Que.—The Brompton Pulp & Paper Co. has decided to abandon certain plans for extensions for the present time. The company has made all arrangements for the development of one of its water-powers and work was to start shortly. The company owns five water-powers, three of which have been developed. The plans drawn in connection with the de-

SYDNEY LETTER

(Continued from page 524.)

to this and all other classes of mine labor. The men at Springhill are not satisfied with the extent of the increase given, and it is expected the Royal Commission appointed to look into matters at Glace Bay will review the Springhill situation also.

The Commission is at the time of writing sitting at Sydney Mines, where it is enquiring into the wage increase asked for by the workmen of the Nova Scotia Steel & Coal Co. It has not as yet been announced whether any settlement has been arrived at, but some increase in wages at these mines is also a foregone conclusion.

The Royal Commission has devoted considerable attention to the possibility of conciliation and amalgamation of the rival miners' labor unions, namely the Provincial Workmen's Association and the United Mine Workers of Nova Scotia. It is thought that a new union will be formed, that the present officers of the existing organizations will retire in favor of new officers of a merged union that will take an entirely different name, and be purely a provincial organization under the laws of Nova Scotia. Whether this amalgamation will take place is not quite certain at the moment, but those who are in favor express considerable optimism as to the probability of amalgamation and the results that may be expected to follow. The Dominion Iron & Steel Co. have also announced a ten per cent. wages increase effective May 1.

The work of excavation for the new bye-product coke-ovens at Sydney is now actively proceeding. The Dominion Steel Corporation, both at the steel works and the collieries is stimulating interest in food production by letting out vacant land for gardening purposes, and by providing horses and ploughs. Arrangements are also being made to use the company's purchasing organization to obtain supplies of seed potatoes, fertilizer, etc.

velopment of a fourth, it is understood, called for the expenditure of \$500,000 to \$750,000, and the company had made financial provision for the amount required.

ELECTRICAL

Walkerton, Ont.—The Hydro-Electric Commission will prepare a scheme for a supply of power to this district.

Brantford, Ont.—The Township Council are preparing to enter into a contract with the Hydro-Electric Commission for a supply of power for domestic use and street lighting. A by-law will be drawn up and submitted to the ratepayers.

Kingston, Ont.—Engineer Gordon Krihs, of the Hydro-Electric Commission, has been going over the line from Napanee to Kingston and arranging for the work to be carried on in getting the sub-station and power house ready. It is expected that the line will be finished the last of August.

GENERAL

Peterborough, Ont.—The American Cereal Co. are planning to rebuild their mill, which was destroyed by fire some time ago. The equipment is being purchased by the Chicago office of the company. They will be in the market shortly for boilers and mechanical stokers.

BUILDING

St. John, N.B.—F. Neil Brodie, architect, has prepared plans for a hotel at Moncton, to cost \$150,000.

Galt, Ont.—The City Council has given the Hydro Commission an additional 12-foot strip on the city square for the site of its new building.

Montreal, Que.—The Catholic School Commission has decided to call for new tenders in connection with the proposed construction of a new school in Maison-neuve.

Cowansville, Que.—The ratepayers have decided to support the School Board and proceed with the erection of a new academy building. Dr. Rodgers is chairman of the board.

Toronto, Ont.—The Provincial Hydro-Electric Commission have purchased a property adjoining their office building on University to provide for future extensions.

Dundas, Ont.—A number of contracts have been let for the new office building for the John Bertram & Sons. The building will cost \$93,000, and the general contractors are P. A. Secord & Sons.

Toronto, Ont.—City Architect Pearce has issued a building permit to the Hydro-Electric Power Commission to erect an addition to their storehouse, foot of Strachan Avenue, at a cost of \$75,000.

PERSONAL

B. E. Michel has been appointed city engineer of Kitchener, Ont., at a salary of \$1,800.

W. I. Gear, of the Robert Reford Co., Montreal, has agreed to give his services to the Imperial Munitions Board as director of steel shipbuilding, and will deal with all questions relating to the construction of steel merchant ships in this country for the British Government. His office will be in Ottawa.

R. P. Butchart, of Victoria, B.C., who has been appointed director of shipbuilding for British Columbia, will have charge of the building of wooden vessels in that province. Capt. J. W. Troup, manager of the British Columbia coast service of the C. P. R., will act as assistant director, with headquarters also at Victoria.

J. H. Welsford, president of the Union Steamship Co., of British Columbia, died recently at his home in Liverpool, England. Mr. Welsford was a prominent shipowner in Great Britain, but frequently visited British Columbia. He purchased a controlling interest in the Union Steamship Co. in 1911.

William Lodge, of the Lodge & Shipley Machine Tool Co., Cincinnati, Ohio, died at his residence in that city on April 30, aged 69 years. He was born in Leeds, England, in 1848, and at the age of 22 went to the United States. Early in 1872 he went to Cincinnati, and in due course became one of the pioneer machine tool builders in that city. Wm. Lodge was one of the first to introduce machine tools made in Cincinnati in England, having established a business connection with Alfred Herbert & Co., of Coventry. In 1893 Mr. Lodge became associated with Murray Shin'ev, and the present firm of Lodge & Shipley was incorporated.

W. D. Jacoway has been appointed superintendent of the open-hearth and electric furnace departments at the new plant of Armstrong, Whitworth of Canada, Ltd., at Longueuil, near Montreal. He was connected with the open-hearth department of the Dominion Iron & Steel Co., Sydney, N.S., and later was with the Bethlehem Steel Co. at South Bethlehem. More recently he has been associated with C. H. Macmillan in installing and operating an electric furnace and open-hearth plant for the Canada Cement Co. at Longue Point, Que. The new plant at Montreal consists of four Heroult furnaces and two open-hearth furnaces.

TRADE GOSSIP

The Turnbull Elevator Co., Toronto, have the contract for elevators for the new C. N. R. station on Dorchester Street, Montreal.

Philipsburg, Que.—The directors of the Missisquoi Marble Co. have ordered the closing down of the marble plant here for an indefinite time.

St. John, N.B.—During the first three months of 1917 the harbor revenues show an increase over the corresponding

The Bawden Machine Co., Toronto, has been awarded a contract by the Thor

Iron Works, Toronto, for 24 cargo winches, 4 windlasses and 4 steering engines.

Contracts for Forgings.—The United States Government has placed contracts for 10,000,000 pounds of steel forgings at approximately 34 cents a pound with the Bethlehem and Midvale Steel Companies, period of last year of \$12,623.04.

Canada Copper Corporation, which was organized several years ago as a financing medium for the British Columbia Copper Co., has taken over the assets of the latter concern, which will now pass out of existence.

The Bawden Pump Co., Toronto, have been awarded a contract for nine pumps, ranging from half-million to three-million gallons' capacity per day, by the Colonial Pulp & Paper Co., Vancouver, B.C.

Montreal, Que.—The recent sale reported of the Delmas Pulp & Paper Co. at St. Amadee de Peribonka, Lake St. John, to Messrs. Barclay & Theriault, is denied by J. P. Marion, who announces that he has already taken steps to float a new corporation to act on his option.

Record Steel Tonnage.—The unfilled tonnage of the U. S. Steel Corporation on April 30 last was 12,183,083 tons, an increase of 471,439 tons over the previous month, and again breaking all previous records. The April gain compares with 11,711,644 March 31, 11,576,697 Feb. 28, and 9,829,551 on April 30 a year ago.

St. Catharines, Ont.—The possibility of the Dominion Government taking over sections one, two and three of the Welland Ship Canal, upon which work has ceased until after the war, is now quite apparent. An agent of the Government is at present in the city taking inventory of the various plants, and it is understood that his mission is based upon the above-named possibility.

Exports Prohibited.—The British Trade Commissioner in Canada has received a cable from the British Board of Trade, London, stating that exports from the United Kingdom of the following goods are prohibited, as from May 1:—Mineral waters, beer, ale, candles, paraffin wax, iron and steel constructional material, tubes, sheets, etc.; plywood, railway material, resinous substances. Licenses are obtainable for goods in transit through the United Kingdom, now affected by import and export prohibitions, except in neutral ships.

Canada and U. S. in Joint Effort.—Cooperation between the United States and Canada in many lines of national endeavor, the whole designed to aid the allies effectively, are indicated by Sir George Foster, who returned to Ottawa recently from Washington, where for two weeks he participated in the allied conference. There is to be joint effort in regard to production, munitions output, shipbuilding, coastal defence, and, quite possibly, in respect to the regulation of food prices. Sir George says the United States are in the war very much in earnest.

Quebec, Que.—The Great Eastern Pulp Co. has just been organized here

for the purpose of erecting and operating pulp and saw mills at Madeleine River, Gaspé County, Quebec. The officers chosen so far are: President, John Mullen, of Bangor, Me.; vice-president, Archibald Hay Cook, K.C., Quebec. There will be a bond issue of \$600,000 and a stock issue of a like amount. The pulp mill will have a capacity of 30,000 tons of ground wood pulp annually, and the output of the sawmill will be 10,000,000 feet. The company owns 200,000 acres of timber lands, assuring an adequate supply.

Work on Bridge Span Progressing.—The work of constructing the new Quebec Bridge span, which is to replace that which collapsed in September of last year, is reported to be going on very satisfactorily. About 75 per cent. of the span is now already manufactured in the shops, and according to a representative of the St. Lawrence Bridge Co., there is nothing to interfere with the progress of the work. They have all the material necessary, and have experienced no shortage of labor. It is expected that there will be another three or four months before the span is completed, ready for placing.

Russian Locomotive Requirements Heavy.—Advices from New York state that the Russian Government has sent out definite inquiries for 1,000 locomotives, and is understood to require 2,000 more, a total of 3,000. The placing of these orders as well as orders for cars is likely to be postponed until Russia gets the loan she expects from this country. In the meantime locomotive companies in the U. S. are at work on the orders placed last December by Russia for 300 engines divided equally between the Baldwin and American Locomotive Co.'s. Shipments of some of the engines have already been made. Payment for these engines is guaranteed by the British Government.

More Track for West Front Required.—Canada has been asked to supply another three hundred miles of trackage for the West front. Last winter several hundred miles of rails were sent from Canada to France, and the request for additional trackage has just been made through the Imperial Munitions Board. The matter has been referred to the Dominion Railway Commission, and Sir Henry Drayton has already arranged for some two hundred miles of trackage, which is to be obtained by lifting the Grand Trunk Pacific tracks west of Edmonton, between Imrie and Resplendent, where the line parallels the Canadian Northern line, and where one railway track can be used by both lines.

Opening New Metal Areas.—In mining circles it is stated that influential New York interests may shortly enter into the development of important molybdenum areas in the neighborhood of Quyon, Que. A number of molybdenum properties have been operated with varying success since war demands stimulated demand for the metal. Technical, as well as financial difficulties have had to be surmounted. It is held in connection with the Quyon venture that it

Tool Room Precision in a 28" Conradson Lathe

made possible by head being cast integral with the bed; therefore of rigid construction and permanent alignment. Spindle is driven by Helical and worm gears,

giving a perfectly even torque. Gears are heat-treated; all end thrusts are taken by ball bearings. We have one new lathe, 28" x 10' with turret tool post

IN STOCK

WRITE FOR DETAILS

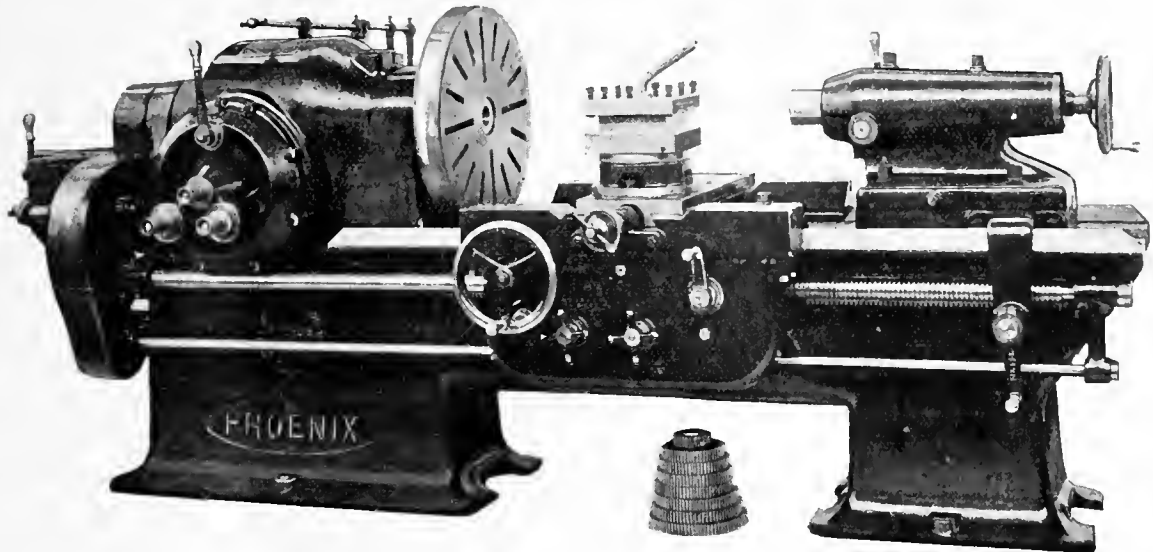

The A. R. Williams Machinery Company, Limited

ST. JOHN, N.B.
WINNIPEG, VANCOUVER

"If It's Machinery, Write Williams"

64 Front Street West
TORONTO

SELECT YOURS

Or let us select it for you.

Let us know the line of thread-cutting you have to do, and we will send you full particulars of the Die Head best suited.

Geometric Self-opening Die Heads that release the work when the required length is reached, are furnished for cutting from 1/16-in. diameter up to the largest requirement, of any pitch and form. Can be arranged for any make of Screw Machine.

The big manufacturers are using them, and the smaller manufacturers cannot afford to do their thread cutting without them.

The Geometric Tool Company

New Haven, Conn., U.S.A.

Canadian Agents:

Williams & Wilson, Limited, Montreal; The A. R. Williams Machinery Company, Limited, Toronto, Winnipeg and St. John, N.B.

Style D

Style C

Taper
Threader

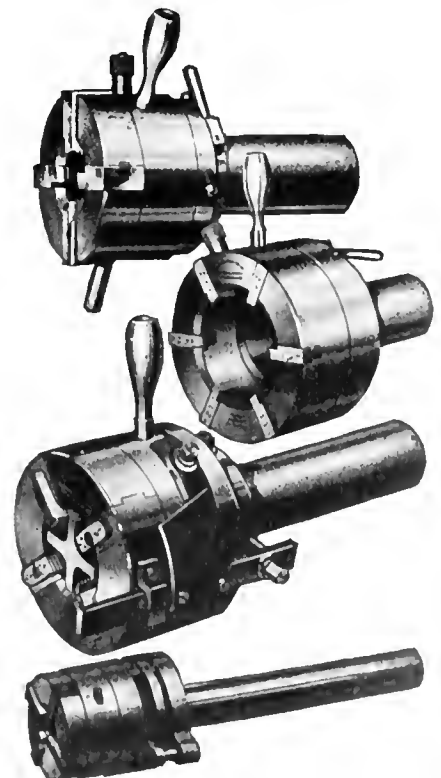

Style D-D for Cleveland and Similar Automatics

If any advertisement interests you, tear it out now and place with letters to be answered.

started out under favorable auspices on the technical side, having the advice of distinguished American experts, and that this has facilitated the enlisting of the support of New York capital. If the promise of the present development is verified it will be another instance of the stimulus of war business to the metallurgical industry of the country.

Alberta Coal Mines Increase Tonnage.—Over 4,648,600 tons of coal were mined in Alberta last year. During this period, 107,959 tons of briquettes and 41,950 tons of coke were made. Several small mines have been opened in the Peace River district, and although at present operated on a small scale, it is probable that with the increased settlement now taking place in the district north of Edmonton, these mines will be fairly large producers in the near future. The output of coal for the year 1916 exceeded that for the year 1915 by 1,213,713 tons, thus establishing a record output for the province. There were 282 mines in operation during the year 1916. Of these, two were copper mines, one a shale mine and two hundred and seventy-nine coal mines. Operations were discontinued at the copper ore mines several months ago, and have not been resumed. The shale mine during the year 1916 produced shale from which 200,000 bricks were manufactured.

Mason Regulator & Engineering Co.—A new company has been organized in Montreal, under the name of Mason Regulator & Engineering Co., and has taken over the well known steam specialty business of H. L. Peiler & Co. there. The new company has also acquired the Canadian business of the Griscom-Russell Co. Eldon Macleod, treasurer of the Mason Regulator Co. of Boston, Mass., is president, while H. L. Peiler will act as treasurer and general manager. It is the intention of the new company to manufacture, in Canada, Mason reducing valves and other pressure regulating appliances, as well as "Bundy" steam traps and "Coppus" blowers besides the marine and steam specialties of the Griscom-Russell Co. These include the well known Reilly heaters, evaporators and distillers which enter so largely into marine equipment. All the other agencies controlled by H. L. Peiler & Co., will be retained, the business being carried along on the same lines as heretofore. The new company will have a greatly strengthened organization. Associated with Mr. Peiler will be E. J. Hatton, formerly of the Canadian Allis-Chalmers Co., who will have charge of the manufacturing and erection work, while the sales end will be taken under Mr. Peiler's supervision, by E. T. Jeffrey, formerly of the John McDougall Caledonian Iron Works, and H. E. Kirkham. The Toronto office will be in charge of J. Collins, late manager of the Canadian Steam Boiler Equipment Co., who is well known to the engineering fraternity in Toronto. The offices of the old firm at 380 St. James St., Montreal, have been overhauled and additional space acquired for taking care of the increased business anticipated.

MUNICIPAL

Trail, B.C.—A by-law will be submitted to the ratepayers on May 22 to raise \$80,000 for extensions to the water-works plant.

Swift Current, Sask.—The Local Government Board has given permission for the issue of \$55,000 debentures for the purchase of a Diesel oil engine.

Davidson, Sask.—A by-law will be voted on by the ratepayers on May 21 to authorize an expenditure of \$8,000 for the construction of a new school and \$4,500 for power house improvements.

Galt, Ont.—The City Council have decided to have a vote of the electors in June on the issue of \$15,000 debentures for the purchase of a drilling outfit, storage lot and buildings for the board of works, and for repairs to the three bridges over the Grand River.

Brantford, Ont.—The Brantford Township Council has instructed the township solicitor to prepare a by-law to be submitted at its next meeting, providing for the township entering into a contract with the Hydro-Electric Commission to secure electric power throughout the township.

Elmira, Ont.—The ratepayers will vote on two by-laws on May 28. The first calls for a loan of \$15,000 to the Elmira Transmission and Machinery Co. The second provides for granting to the Phonola Co., of Canada, a free deed of \$2,500 mortgage. The first company would increase its capacity by the addition of buildings 50 x 50 feet and 50 x 88 feet, and an extra dry kiln. The second company will begin operations at once.

Regina, Sask.—Work on the construction of the new power house at Boggy Creek will be commenced shortly and the order for the new three million gallon electrical pumping unit will be placed before the end of this month. When the new unit is installed the capacity of the plant will be nearly doubled, and it would be possible to pump seven million gallons a day if that amount were required. The estimated cost of building and unit is in the neighborhood of \$10,000. Two transformers will also be installed.

TENDERS

Three Rivers, Que.—The City Council are receiving bids on four turbine pumps, each having a capacity of between 2½ and 3 million gallons per day.

St. Lambert, Que.—Tenders will be received up to May 28, for the supply and installation of a horizontal shaft centrifugal pump, electric motor and switchboard. Specifications may be obtained from H. A. Gibeau, town engineer.

Toronto, Ont.—Tenders, addressed to the chairman, Board of Control, will be received up to May 22 for two five-ton gasoline motor trucks and two three-and-a-half ton gasoline motor trucks for the Department of Street Cleaning. Forms of tender and conditions of tendering may be had on application at the office of the Street Commissioner, City Hall.

Toronto, Ont.—Tenders will be received up to Tuesday, June 5th, 1917, for the sale and removal of four horizontal re-

turn tubular boilers from the west boiler room of the City Hall, Toronto. Copy of terms and conditions may be seen, and tender form obtained, together with all information relative thereto, at the offices of the Property Department, City Hall.

Winnipeg, Man.—Tenders, addressed to the chairman, Board of Control, will be received up to May 18 for the supply and delivery, f.o.b. cars Winnipeg, freight and duty paid, to siding on Saskatchewan Avenue at the Decarie incinerator, of two horizontal water tube boilers. Plans, specifications and form of tender may be obtained at the office of the city engineer, 223 James Avenue. Lambert, Chambly Co., P.Q.

Brantford, Ont.—Tenders will be received by the secretary of the Board of Water Commissioners, until May 28, for two electrically-driven turbine pumps with capacity of 300 gallons per minute each, also electric motors and equipment. Specifications, etc., may be seen at the office of the secretary of the Board, Brantford, or at the engineer's office, Chipman & Power, Mail Building, Toronto.

CONTRACTS

Montreal, Que.—The Canadian Car & Foundry Co., has closed an order with the Canadian Government Railways for one thousand freight cars.

Agincourt, Ont.—In response to a request from the Town Council to the Hydro-Electric Commission, it is expected that they will commence extending their system of lights to Scarborough Junction and Agincourt at an early date.

Guelph, Ont.—The Water Commissioners have awarded the following contracts for annual supplies:—Cast iron pipe, National Iron Works, Toronto; valves, Kerr Engine Co., Walkerville; brass goods, Canada Brass Co., Galt.

Ottawa, Ont.—Official announcement was made last Thursday that a contract had been granted for \$5,200,000 to the estate of James Davidson, Ottawa, for the supply of spruce plank to be used in the reconstruction of the new Parliament Buildings. Tenders have also been awarded for the terra cotta fire proofing. The National Fire Proofing Co. have been given the tender for the 12-inch, 10-inch, and 9-inch terra cotta arch tile. The Sun Brick Co. was the successful tenderer for the interlocking 3-inch partition tile. The Montreal Terra Cotta Co. was given the tender for the 4-inch and 2-inch tile furring.

MARINE

Sault Ste. Marie, Ont.—The weather continues unfavorable and heavy ice is interfering with navigation. A large number of freighters have been held up.

South Vancouver, B.C.—The Board of Trade have started a movement to establish a shipbuilding plant here on the Fraser River, at the foot of Quebec Street.

Welland, Ont.—The Welland Shipbuilding Co., which was recently incorporated with a capital of \$200,000, has

Aikenhead's

"Van Dorn"

**Portable Electric Drills
Reamers and Grinders**



THEY consume current only when working, and any lamp socket is a source of power. You will find hundreds of uses for them around your shop and they are dependable. Special fan-cooled Van Dorn motor has 100% overload capacity. Van Dorn make-and-break switch acts so quickly that it practically eliminates the sticking and fusing of contacts. Phosphor bronze and ball bearing. Gears cut and hardened. All parts 100% oversize.

Do more work at less cost and they stay on the job.

For Full Particulars, Write

AIKENHEAD HARDWARE LIMITED

17, 19, 21 TEMPERANCE STREET, TORONTO

Aikenhead's
**Wahlstrom
Automatic
CHUCKS**

You can save 20%
on Tapping Jobs.

Possibly you don't
think this can be
done, but the
Pierce-Arrow Co.
did it, with

**Wahlstrom
Automatic Chucks**

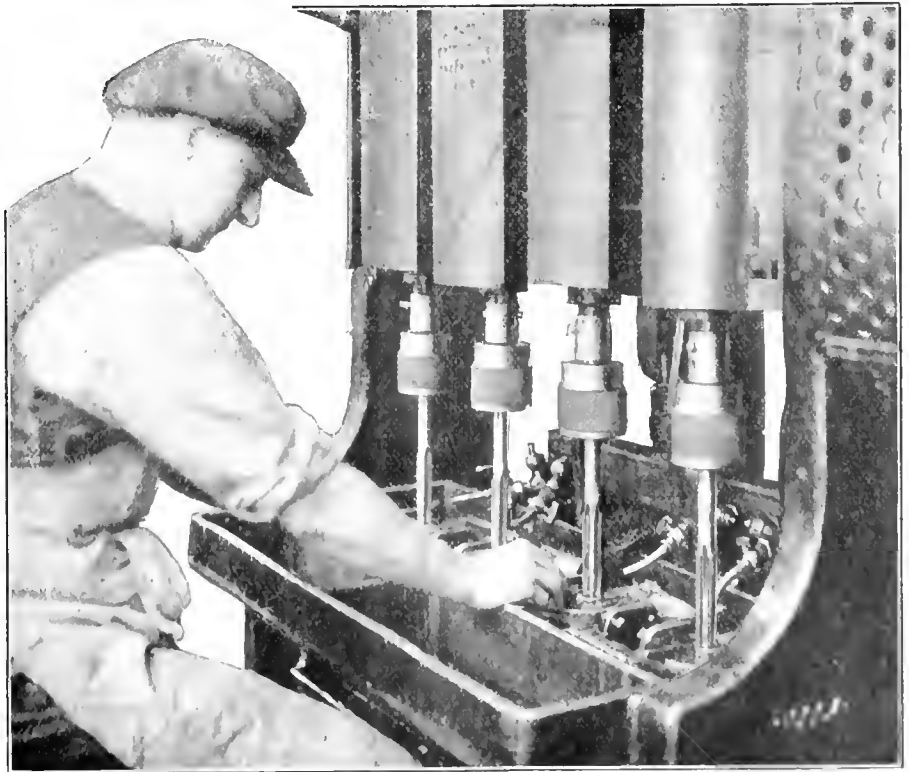

Aikenhead Hardware Limited, 17 Temperance Street
Toronto

If any advertisement interests you, tear it out now and place with letters to be answered.

PATENT ATTORNEYS

BABCOCK & SONS

ESTAB. 1877.

PATENTS—TRADE MARK—DESIGNS
IN ALL COUNTRIES

Book "Patent Protection"—free. Master of Patent Laws, Formerly Patent Office Examiner.

99 St. James St., - Montreal, Que.
Branches: Ottawa, Washington.

RESEARCH BUREAU

REPORTS BY EXPERTS ON SCIENTIFIC, TECHNICAL AND INDUSTRIAL DEVELOPMENT.
SPECIAL RESEARCHES ARRANGED.

PATENTS, TRADE MARKS, ETC.

HANBURY A. BUDDEN CABLE ADDRESS
712 DRUMMOND BLDG., MONTREAL "BREVET"

PATENTS

Fetherstonhaugh & Co.
Patent Solicitors, Head Office,
Royal Bank Bldg., Toronto,
Ottawa Office, 5 Elgin St.
Send for our Plain Practical
Pointers, Copy of National
Progress, in which our patents
are advertised, mailed free.

PATENTS PROMPTLY SECURED

In all countries. Ask for our Investor's Adviser, which will be sent free.

MARION & MARION, 364 University St.
Merchants Bank Building, corner
St. Catherine St., MONTREAL, Phone Up. 6474
and Washington, D.C., U.S.A.

MORTON MANUFACTURING CO.

PORTABLE PLANERS
DRAW CUT SHAPERS
SPECIAL DRAW CUT R.R. SHAPERS
FINISHED MACHINE KEYS
STATIONARY & PORTABLE KEY WAY CUTTERS
SPECIAL LOCOMOTIVE CYLINDER PLANERS

OFFICE AND WORKS: MUSKEGON HEIGHTS U.S.A.

YOU

should read the classified
advertising pages.

There is something there
which is meant for you.

Don't Overlook It!

CANADIAN MACHINERY

Classified Advertising Section

143-153 University Avenue

TORONTO, ONTARIO, CANADA

taken over M. Beatty & Sons' shipyard and machine shop for a term of years, for the construction of steel freighters. A permit has been secured for building an additional slip on the Welland Canal.

WOODWORKING

Toronto, Ont.—Damage estimated at \$1,000 was done to Hippen Brothers' sash and door factory at 746 Pape Avenue, last Thursday, by fire of unknown origin.

Port Hope, Ont.—On May 5, at Bewdley, a village at the head of Rice Lake, the sawmill with all its machinery and a large quantity of logs and lumber, were destroyed by fire. The mill was owned by ex-Mayor T. B. Chalk, of Port Hope, and the loss is partially covered by insurance.

RAILWAYS—BRIDGES

Prince Albert, Sask.—Work is being pushed forward on the laying of steel from the south branch of the Saskatchewan River into Prince Albert, giving the G.T.P. entrance to this city. It will mean a considerable shortening of the journey from this point to Winnipeg and the East, and will open up a splendid and already well settled agricultural country.

REFRIGERATION

Brockville, Ont.—The engineers are at work installing the cold storage apparatus in the new buildings of the Laing Produce and Storage Co., which was formerly occupied by the Bowie Brewing Co. The company expects to start work immediately on the installation of a milk condensing plant, which will have a capacity of 75 tons of milk daily. It is expected that this portion of the plant will be in operation by September 1st.

INCORPORATIONS

Kamloops Sawmills Ltd., has been incorporated at Ottawa with a capital of \$50,000 to operate sawmills and planing mills etc., at Kamloops, B.C. The incorporators are James C. Shields, James L. Broadfoot and William J. Baird all of Vancouver, B.C.

The **National Potash Corporation**, has been incorporated at Toronto with a capital of \$1,500,000 to acquire and develop mineral lands and deposits. The head office is at Toronto and the incorporators are T. A. Gillen, Solomon Grand and F. C. Lee all of Toronto.

Prairie Chemical Co., Canada, Ltd., has been incorporated at Ottawa with a capital of \$100,000 to manufacture chemicals of all kinds at Winnipeg, Man. The incorporators are George St. John, Van-Hallen, William C. Graham and Humphrey E. Buchan all of Winnipeg.

Eldridge Motors Co., have been incorporated at Ottawa with a capital of \$40,000 to carry on business as iron founders and mechanical engineers at Calgary, Alta. The incorporators are Arthur S. Eldridge, James G. Fenton and Frank T. Kach all of Seattle, Wash.

Burroughs Adding Machine of Canada, Ltd., has been incorporated at Ottawa with a capital of \$250,000 to manufacture adding, counting and writing machines at Windsor, Ont. The incorporators are A. J. Lauver, Charles G. Chapman and Eric T. Clarke all of Detroit, Mich.

CATALOGUES

Atlas Arbor Presses.—Bulletin illustrating and describing a line of presses made by the Atlas Press, Kalamazoo, Mich. A specification is included giving the principal dimensions of the various sizes of press.

The Wetmore Mechanical Laboratory Co., Toronto, have issued a new bulletin, No. 100, featuring an interesting line of small tools and gauges for munition manufacturers, including thread milling hobs, sizing taps, reamers, etc.

Band Ship Saw.—The J. A. Fay & Egan Co., Cincinnati, Ohio, are distributing copies of a new bulletin, M-19, describing No. 311 "Lightning" band ship saw, which is a new machine designed to meet present day ship-building requirements. The principal features of this band saw are dealt with fully, accompanied by illustrations showing the machine set at various angles.

Steam Pumps.—The G. H. Tod Co., Toronto, have issued a new booklet giving the practical ratings for the Tod-Attwood patent steam pumps. The tables have been carefully compiled and will be of great assistance to the prospective purchaser in selecting the correct size of pump for various classes of work. The tables show at a glance the capacity of each size of pump at different piston speeds.

Overhead Traveling Cranes.—The Brown Hoisting Machinery Co., Cleveland, Ohio, have issued a new catalogue P, describing the "Brownhoist" overhead hand-traveling cranes. The catalogue contains a full description of the single and double I beam cranes with illustrations of details and price lists giving the capacity and other particulars for various spans. Dimension diagrams for ordering are also included. Other illustrations show a number of installations in various plants, while "Brownhoist" crane-trolleys are also described and illustrated.

Transmission Ball Bearings.—The Canadian S. K. F. Co., Toronto, have issued a new and attractive catalogue dealing with S. K. F. self-aligning ball bearing hangers and pillow blocks. The construction of the bearing and its self-aligning feature are described at length, accompanied by sectional illustrations showing the general design. A variety of other matters of interest to users of ball bearings are dealt with, including such questions as the saving of lubricant, saving of power, reduction of transmission losses, belt saving, etc. The concluding pages of the catalogue contain dimensions, tables and list prices of ball bearing hangers, post hangers, and pillow blocks covering the various sizes of each type.

We Want Good Men

WE want a live wire representative in every good sized shop in Canada. We are willing to pay liberally for a little spare time. The work, moreover, is congenial, and whoever undertakes it will have the satisfaction of knowing that he has done his co-workers a good turn.

One of our representatives recently made \$10.00 in his spare time in one week. This is worth investigating, Mr. Foreman, Mr. Tool-maker, Mr. Timekeeper, Mr. Draughtsman, Mr. Machinist. Won't you let us send you full particulars?

COUPON

SEND US YOUR NAME
 CANADIAN MACHINERY
 153 University Ave., Toronto

Gentlemen:
 Please send me full particulars of your proposition re representatives.

NAME.....
 Street Address.....
 Town.....
 Where Employed...
 Position.....

BOOK REVIEWS

Modern Milling, by Ernest Pull, A.M.I.M.E., is the title of a 200-page book recently published by Whittaker & Co., London, England, \$1.85 net. This is a practical manual on milling operations in all its various branches, covering this section of engineering in a very thorough and comprehensive manner, and can be readily understood by anyone familiar with ordinary shop practice. A feature of this treatise is the absence of those algebraic terms that are generally so confusing to the average mechanic. The formulae that appear throughout the work, and in connection with the numerous tables, are of a character that can be easily grasped by all who understand the fundamental principles of elementary arithmetic. In addition to the detailed description of design and construction of different types of milling machines, special attachments and fixtures, practical workshop problems, with their solutions, are profusely distributed throughout the ten chapters of the book. The work is divided into sections, each chapter dealing with certain phases of milling practice, such as universal and plain milling machines, vertical, special and profiling machines, milling attachments and accessories, indexing, gear cutting, spur gears, gear cutting, spiral gears, bevel and worm gears, milling operations, milling cutters and arbors, speeds and feeds. With 188 illustrations and numerous tables, this work should prove a very valuable reference to those associated with modern milling and general machine shop practice.

NEW RAILWAY LINE ACROSS EUROPE

By Mark Meredith.

M. HERRIOT, Mayor of Lyons and Senator of the Rhone, has put before the French public a scheme for the construction of a new transcontinental line which will link France to Russia, via Italy, instead of via Berlin. Before the war, there was only one great overland route: Paris-Berlin-Warsaw-Moscow or Petrograd, with the Berlin-Koenigsberg alternative. As Italians have pointed out recently, it will henceforth be possible, without the least difficulty, to create a direct route between France and Russia which will be quite independent of Germany. It would run from Bordeaux, through Lyons, Turin, Milan, Trieste, Belgrade, and Bucharest, to Odessa. Such a railway route would not only provide a substitute for that of Berlin-Petrograd, but also to that of Bagdad, for it would be easy to send a branch line to Constantinople.

This new transcontinental line, which the Italians have termed that of the Forty-fifth parallel, and which would extend, if calculations are exact, over 3,600 kilometers (instead of 6,200 kilometers by the sea route), would permit of the rapid transport of passengers, mail, parcel post, valuable and perishable goods.

The famous Gothard convention, which will have to be considered at the

time of the signing of the treaty of peace would no longer be harmful to the interests of the Entente Powers. France and Italy would reap immense benefits from such a scheme, which would be the great economic event of the alliance which owes its existence to the war. Germany would lose her power of control, for she would find herself enveloped on the north by a maritime route between France and Russia and on the south by the new overland route.

The political advantages of such a scheme need hardly be pointed out. The entire situation in the Balkans would be improved by the possibility of easy and uninterrupted relations. The future of Serbia and Rumania would be assured, and they would be freed from their economic dependence on the Central Empires. The French and Italian Governments are very favorable to the scheme. Southern Russia is on the eve of immense development, which necessitates due preparation and provision.

This line would be the true Metropolitan of Europe, but in order to be ready for its inauguration at the proper time, it is essential that the necessary reports on the work to be done should be made now. The administration of such a line, the tariffs, and all necessary details, should be gone into and fixed. Circumstances are in our favor. They have brought Great Britain, France, Italy, Serbia, Rumania, and Russia together, and the opportunity thus provided should not be lost.

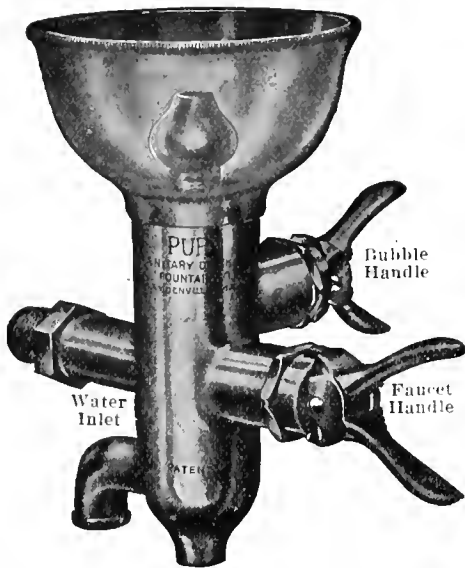

Saving or Wasting?

The manner in which you handle the drinking water problem in your plant may seem to be a small matter to you—but investigate. The results will be surprising.

The old-time faucet is costly. Running hour after hour, day after day, its ceaseless flow is costing you money, yet without any better service.

Puro Saves 35%

A Puro Sanitary Drinking Fountain will cut that water bill 35%. We can prove that it has done that for others.

It will give every employee a safe, snar draught of bubbling water free from the contamination of the common drinking cup.

In a word, it is the only sanitary Drinking Fountain that is really safe, sanitary, simple, automatic in control, and easy to attach.

"PURO - FY"

(MADE IN CANADA)

YOUR WATER SUPPLY

Puro Sanitary Drinking Fountain Company
147 University Ave., Toronto, Canada

THE IRON WORKS LIMITED

Successors to

Owen Sound Iron Works

Owen Sound, Ont.

Engineers

Boiler-makers

Founders

Machinists

Tank Work
Smoke Stacks,
Grey Iron and
Brass Castings,
Special
Machinery
Made to
Order

METAL STAMPINGS

We are manufacturers of stamped parts for other manufacturers.

We do any kind of sheet metal stamping that you require. Our improved presses and plating plant enable us to produce the finest quality of work in a surprisingly short time.

We can finish steel stamping in Nickel, Brass or Copper.

Send us a sample order.

W. H. BANFIELD & SONS

372 Pape Avenue, Toronto, Can.

CANADIAN MACHINERY AND MANUFACTURING NEWS

A weekly newspaper devoted to the machinery and manufacturing interests.

Vol. XVII.

TORONTO, MAY 24, 1917

No. 21

EDITORIAL CONTENTS

Oxy-Acetylene Welding in the Machine Shop and Tool Room	527-530
General	530
Smoke Prevention....Power Plant Operation and Management.	
Suggestions on the Standardization of Machine Tools	531-536
General	536
Special Alloys and Their Composition.	
Editorial Correspondence	537-538
Foundrymen and Price Cutting....Serviceable Emery Cloth Board....Getting the Most Out of a Saw....What is Hardness....Mechanics' Training College.	
Uniform System of Foundry Cost Accounting	539
General	539-540
Power for Steel Mills....Turbine Gear Lubrication—Utilization of Peat as Fuel.	
Spokes in Industry's Wheel	541-542
John Wilkie Taylor.	
General	542
Toronto Branch C.M.A. Annual Meeting.	
Progress in New Equipment	543
24-inch Helical Gear Shaper....½ K.W. Domestic Lighting and Power Plant.	
General	543-544
Death Summons A. R. Williams....British Trade Corporation....Shipbuilding Dif- ficulties....The Electric Furnace.	
Editorial	545
Men Whom We Can Ill Spare....Conscription.	
Selected Market Quotations	546-547
The General Market Condition and Tendency	547-552
Summary....Montreal Letter....Toronto Letter....Pittsburgh Letter.	
Industrial and Construction News	62-66

THE MACLEAN PUBLISHING COMPANY, LIMITED

JOHN BAYNE MACLEAN, Pres. H. T. HUNTER, Vice-pres. H. V. TYRRELL, Gen. Man.
Publishers of Hardware and Metal, The Financial Post, MacLean's Magazine, Farmer's Magazine,
Canadian Grocer, Dry Goods Review, Men's Wear Review, Printer and Publisher, Bookseller and
Stationer, Canadian Machinery and Manufacturing News, The Power House, The Sanitary Engineer,
Canadian Foundryman, Marine Marine Engineering of Canada.

Cable Address: Macpubco, Toronto; Atabek, London, Eng.

ESTABLISHED 1887

CANADIAN MACHINERY AND MANUFACTURING NEWS

PETER BAIN, M.E., Editor. B. G. NEWTON, Manager.
Associate Edl.ors: A. G. WEBSTER, J. M. WILSON, J. H. RODGERS.

CHIEF OFFICES:

CANADA Montreal, Southam Building, 128 Bleury Street, Telephone 1001; Toronto, 143-153 University Ave.,
Telephone Main 7324; Winnipeg, 22 Royal Bank Building, Telephone Garry 2313.

GREAT BRITAIN—LONDON, The MacLean Company of Great Britain, Limited, 88 Fleet Street, E.C., E. J. Dodd,
Director, Telephone Central 12960. Cable Address: Atabek, London, England.

UNITED STATES New York, R. R. Huestis, Room 620, 111 Broadway, N.Y., Telephone Rector 8951; Boston, C. L.
Morton, Room 733, Old South Building, Telephone Merin 1201. A. H. Byrne, 1101-5-6-7 Fort Dearborn Bldg.,
105 W. Monroe St., Chicago, Telephone Randolph 323-.

SUBSCRIPTION PRICE Canada, Great Britain, South Africa and the West Indies, \$3.00 a year; United States,
\$3.50 a year; other countries, \$4.00 a year; Single Copies, 15 cents. Invariably in advance.

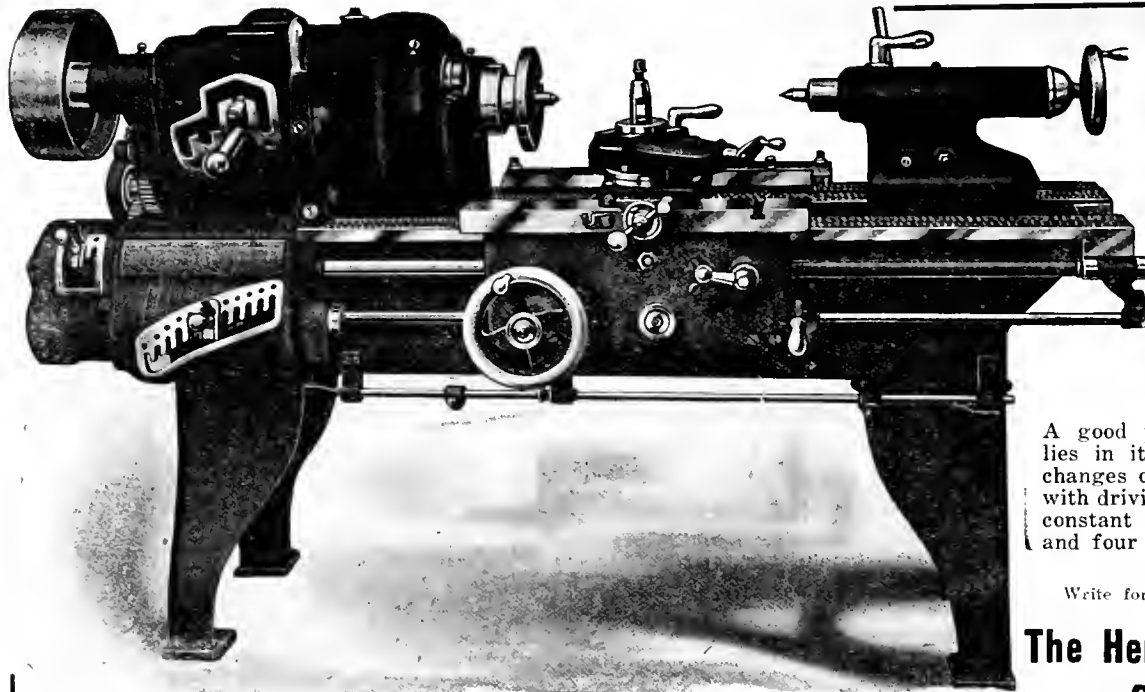

Hendey 18-inch Geared Head Lathe

A good point in this lathe lies in its eight mechanical changes of speed for spindle with driving shaft running at constant speed—four direct and four through back.

Write for descriptive circular.

The Hendey Machine Company Torrington, Conn.

Canadian Agents: A. R. Williams Machinery Co., Toronto, Ont.; A. R. Williams Machinery Co., 260 Princess St., Winnipeg; A. R. Williams Machinery Co., Vancouver; A. R. Williams Machinery Co., St. John, N.B.; Williams & Wilson, Montreal.

SPEED, ACCURACY, ADAPTABILITY

Thirty-six different threads and feeds are had through mounted change gearing, each change being quickly made through controlling handles in gear boxes. Lathe has automatic stop for stopping carriage in either direction when feeding or screw-cutting—invaluable for internal work to shoulders and for duplicating pieces.

INDEX TO ADVERTISERS

A	D	K	Pratt & Whitney.....Inside front cover
Adams, Ogden R. 94	Davis-Pommonville Co. 92	Kennedy, Wm., & Sons 14	Pringle, R. E. T., Ltd. 27
American Pulley Co. 86	Davis, W. F., Machine Tool Co. 75	King, Ltd., Warden 20	Puro Sanitary Drink'g Fountain Co. 64
Armstrong Bros. Tool Co. 93	Deloro Smelting & Refining Co. 4		R
Armstrong, Whitworth of Canada... 12	De Alroy Mach. Co. 97	L	Racine Tool & Machine Co. 81
A. S. K. Chemical Co. 66	Diamond Saw & Stamping Works. 82	L'Air Liquide Society 26	Rhodes Mfg. Co. 26
Atlas Crucible Steel Co. 9	Dominion Forge & Stamping 87	Landis Machine Co. 92	Richmond Mfg. Co. 89
Atkins, Wm., & Co., Ltd. 11	Dominion Machinery Co. 72	Lancashire Dynamo & Motor Co. 30	Riverside Machy, Depot 69, 71
	Dominion Steel Foundry Co. 91	Latrobe Electric Steel Co. 15	Rivett Lathe & Grinder Co. 110
	Drury Co., H. A. 7	Lynd-Farquhar Co. 25, 71	Rocklson Machine & Tool Co. 17
B	E	M	Roper & Co., C. F. 86
Babeock & Sons 66	Eastern Mach. Screw Corp. 86	MacKinnon, Holmes & Co., Ltd. 66	S
Baird Machine Co. 91	Elmes, Chas. F. 24	Manufacturers Equipment Co. 87	Shuster Co., F. B. 94
Banfield, E. J. 14	Eric Foundry Co. 24	Martin & Marion 66	Silver Mfg. Co. 93
Banfield, W. H., & Sons. 65		Marsh & Henthorn, Ltd. 103	Skinner Chuck Co. 91
Barnes, Wallace, Co. 75	F	Martin Mach. Co. 30	Standard Alloys Co. 9
Bath, Cyril J. 71	Fairley, Davidson Steel Co. 13	Matthews, Jas. H., & Co., Inc. 72	Standard Electrical Tool Co. 27
Baxter & Co., Ltd., J. R. 15	Fetherstonhaugh & Co. 66	McCabe, J. J. 70	Starratt Co., L. S. 167
Beatty & Son, M. 73	Fitzgerald, W. H. J. 70	McCoy-Brandt Machy. Co. 70	Steel Bending Brake Works, Ltd. 19
Bernard Industrial Co., A. 85	Foss & Hill Machy. Co. 16	McDonnell Co., B. Inside back cover	Stecher Co., Chas. 19
Bertram, John, & Sons Co., Ltd. 1	Francis & Co. 93	McClean & Son, F. W. 77	Steel Co. of Canada 5, 73
Bilton Mach. Tool Co. 16		McLaren, J. C., Belting Co. 92	Stephoe, John, Co. 75
Blake & Johnson Co. 103	G	Mechanical Engineering Co. 83	Stocker-Rumley-Wachs Co. 75
Blount, J. G. 22	Gayler Machine Co. 106	Metal Manufacturers' Service. 76	Snow Mfg. Co. 103
Bramford Oven & Rack Co. 5	Garlock-Walker Machy. Co. 73	Metalwood Mfg. Co. 25	Swedish Gage Co., Inc. 80
Bridgeford Mach. & Tool Works. 55	Geometric Tool Co. 19	Milholland Co., W. K. 19	Swedish Steel & Importing Co. 12
Bristol Company 91	Gilbert & Barker Mfg. Co. 82	Monarch Brass Mfg. Co. 77	T
Brownell Machy. Co. 11	Grant Gear Works, Inc. 92	Montreal Machy. & Supplies 99	T. C. M. Mfg. Co. 20
Brown's Copper & Brass Rolling Mills 79	Grant Mfg. & Machine Co. 28	Morse Twist Drill & Mach. Co. 63	Tabor Mfg. Co. 36
Budden, Hambury A. 66	Greenfield Machine Co. 92	Morton Mfg. Co. 43	Tate-Jones & Co., Inc. 82
		Motch & Merryweather Machy. Co. 74	Taylor Instrument Co. 83
C	H	Murphy Machine & Tool Co. 88	Toomey, Frank A. 74
Can. Bond Hanger & Coupling Co. 85	Hamilton Gear & Machine Co. 76	N	Toronto Iron Works 91
Canada Machinery Corporation Outside back cover	Hamilton Machine Tool Works. 21	Napier Saw Works, Inc. 92	Toronto Testing Lab. 94
Canada Metal Co. 67	Hanna & Co., M. A. 15	National Machine Tool Co. 93	Toronto Tool Co. 76
Can. B. K. Morton Co. 6	Hawkridge Bros. 63	New York Machinery Exchange. 74	Trahern Pump Co. 84
Can. Bridge Co., Ltd. 71	Hendey Machine Co. 11	Nicholson File Co. 81	Transcona Shell Co. 70
Can. Fairbanks-Morse Co. 34	Henry & Wright Mfg. Co. 97	Niles-Bement-Pond. Inside front cover	U
Can. Pairsbanks-Morse Co. 39	Hepburn, John T. 18	Northern Crane Works 91	United Hammer Co. 92
Can. Desmond-Stephan Mfg. Co. 101	High Instrument Co. 83	Norton, A. O. 92	United States Electrical Tool Co. 39
Can. Economic Lubricant Distributors, Ltd. 29	Himoff Mach. Co. 94	Norton Co. 32	V
Can. Ingersoll Rand Co., Ltd. 9	Hovt Metal Co. 94	Norton Grinding Co. 33	Vanadium Alloys Steel 16
Can. Inspection & Testing Laboratories, Ltd. 91	Hull Iron & Steel Edries, Ltd. 24	Nova Scotia Steel & Coal Co. 10	Vulcan Crucible Steel Co. 15
Can. Mathews Gravity Carrier Co. 65	Hungeford Brass & Copper Co. 78	O	W
Can. Metal Products 76	Hurlbut-Rogers Machinery Co. 93	Ontario Specialties, Ltd. 94	Walcott Lathe Co. 16
Can. Morehead Mfg. Co. 22	Hyde Engineering Works 13, 77	Oven Equipment & Mfg. Co. 84	Warner & Swasey Co. 5
Can. Steel Foundries, Ltd. 7		Over Machy. Co. 16	Wells Bros. Co. of Canada 32
Can. S. K. F. Co., Ltd. 11	I	P	Whiting Foundry Equipment Co. 88
Carlyle Johnson Mach. Co. 8	Ideal Tool & Mfg. Co. 89	Parmenter & Bulloch Co. 94	Whitman & Barnes Mfg. Co. 169
Chapman Double Ball Bearing Co. 85	Independent Pneumatic Tool Co. 29	Peerless Machine Co. 81	Williams & Kompass 93
Cincinnati Pulley Machy. Co. 101	Iron Works, The 69	Perrin, Wm. R. 25	Williams, A. R., Machinery Co. 7, 61
Cleveland Pneumatic Tool Co. 28		Petrie of Montreal, H. W. 69	Williams, Co., J. H. 26
Clippier Belt Lacer Co. 93	J	Petrie, H. W., Ltd. 69	Willson & Co., T. A. 92
Cook, Asa S. 93	Jacobs Mfg. Co. 88	Port Hope File Mfg. Co. 28	Wilmarth & Norman Co. 87
Collen Machy. Co., C. W. 70	Jencks Mach. Co. Front cover	Positive Chufch & Pulley Works. 94	Wimbor Mach. & Tool Works. 87
Cumblings & Son, Lbl., J. W. 12	Jobbon, Geo. E. 65		Winnipeg Gear & Engineering Co. 77
Curtis & Curti Co. 98	Johnson Mach. Co., Carlyle 8		Z
Cushman Chuck Co. 71	Jones & Glasco 84		Zenith Coal & Steel Products Co. 92

Oxy-Acetylene Welding in the Machine Shop and Tool Room

Staff Article

Autogenous welding, on account of its adaptability to general engineering practice, has become an indispensable factor in metal manufacturing industry; the field, however, has been somewhat restricted, owing largely to the lack, on the part of many blow-pipe operators, of the fundamental knowledge required for the proper manipulation of the work upon which they are engaged. The subject matter herewith shows to what extent this process can be adapted to the requirements of general machine shop and tool-room construction and repairs.

DURING the last few years considerable progress has been made in the autogenous welding of metals by the oxy-acetylene process, and recently, engineers and manufacturers have realized its undoubted possibilities in lowering costs of production. As an adjunct to the tool room, the saving effected by this process has been particularly noticeable. In the construction of a jig or fixture, one has generally the choice of two methods: to prepare a pattern from which a casting is made, or to build up from stock material or forgings; each having its own advantages. With the first method welding is not required, unless it is to reclaim a casting that has been spoiled through error, or developed blow holes in machining, when welding would affect the repairs rapidly and cheaply.

It is in the construction of jigs of the built-up type that oxy-acetylene welding will be found of the greatest benefit. The

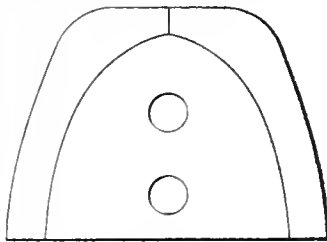

FIG. 1. STELLITE-FACED CUTTER.

majority of them can be built up from old pieces of material, while the use of intricate forgings is done away with. In such cases, the alternative would be to drill, screw down and dowel the parts together, a method which is never very satisfactory, particularly if the jig is subjected to much vibration, as the screws always have a tendency to work loose. Parts can also be welded quickly together, that, from their shape, could not be screwed with any security. Bosses, ribs, webs, etc., can be built up direct from the feed rod, allowing material of lighter section to be used, and dispensing with a great deal of machining. Snap and other gauges of the fixed limit type can be reclaimed when worn out, at a very trifling cost, by adding new metal to the jaws and regrinding to the proper size. This is one instance only of the innumerable ways that the oxy-acetylene plant handles not only efficiently and quickly, but very cheaply, the numberless jobs which come into the tool room from day to day.

Case Hardening

Ordinary case hardening is generally obtained by carbonizing the outside shell

of mild steel pieces, thus transforming the exterior skin to a high carbon steel, giving hardness. Such result is obtained by putting the castings or other pieces, in contact with incandescent carbonaceous substances, so that the metal absorbs the carbon. The characteristics of a case hardened piece are shown by the thickness of the skin transformed in the steel, and as the percentage in carbon decreases from the outside to the inside, a case hardening well done should affect a sufficient thickness of metal treated, and the percentage of carbon should decrease gradually from the outside to the inside and should not be constituted by a film of hard metal without a transitory period of the original metal. Case hardening done by means of an ordinary mixture made of charcoal, carbonate of baryum, or organic matter, gives layers very resisting which do not split even when showing much hardness, because the decrease of carbon is regular; but case hardening made by rubbing special powder (generally containing ferro cyanide of potassium), on small parts which are red hot, gives a very hard skin but not very thick, which is liable to flake away during tempering.

The use of the oxy-acetylene blow-pipe for case hardening permits the obtaining at will, according to the handling of the blow-pipe, either of the above described results; that is to say, a deep layer with gradually decreasing percentage of carbon, or a thin, very hard layer. To obtain quick and deep case hardening, the blow-pipe should be well regulated and the end of the inside tip of the flame should be kept at a distance of about one inch of the metal to be treated; when the desired temperature is attained, a slight excess of acetylene should be given. The flame contains an excess of free carbon which is very readily absorbed by the metal, which is being kept hot by the heat of the flame. To obtain a thin and very hard layer, the inside tip of the flame should be kept close to the part being treated, care being taken at all times not to burn the metal.

The following results have been obtained from experiment, care being taken to keep the pieces at a cherry red heat while being treated: (a) With the white inside cone of the flame kept for two minutes, at $\frac{5}{8}$ inch off the metal, open hearth steel has given a high carbon layer of metal $\frac{1}{2}$ m.m. deep, and the surface of the metal showed a percentage above two per cent., consequently giving a case hardening similar to chemical powder. (b) Holding the inside flame of a blow-pipe, with an excess of acetylene, $1\frac{1}{4}$ in. from the metal during

a period of ten minutes, the case hardening affected a thickness of three mm. without the exterior skin, showing a richness of carbon superior to 0.85 per cent. of carbon. Consequently, case hardening by the blow-pipe gives very interesting results; an application of 2 minutes is sufficient to give to a surface a hardness comparable to the treatment of the most active hardening powder, while by lengthening the application to from 5 to 10 minutes, case hardening can be obtained showing a depth treated of 2 or 3 millimeters, of a very regular character, and with a gradually decreasing percentage of carbon, the highest percentage not being high enough to provoke flake during tempering.

Surface Hardening

The use of the blow-pipe for case hardening should not be confused with its use for surface hardening. In the first

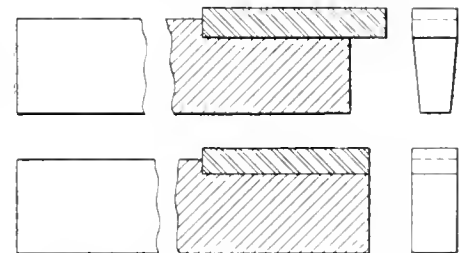

FIGS. 2 AND 3. OXY-ACETYLENE AND ELECTRICALLY WELDED TOOLS.

case, the excess of carbon purposely produced in the flame, changes the chemical composition of the steel being treated, while kept hot with the blow-pipe; while in the second case of surface hardening, only the heating power of the blow-pipe is used as a convenient way to apply heat to the surface of a piece of steel, while the rest is kept cool with running water or other devices. This oxy-acetylene hardening process is a cheap and rapid method of hardening; it is applicable to such purposes as the hardening of the surface of gear teeth, castellated shafts and bores, template holes, and in general to the localized hardening of any small areas upon large articles, particularly where the ordinary hardening process would cause distortion that would be difficult to remove afterwards by grinding.

Surface Hardening of High Tensile Steels

A system of surface hardening which can be applied to local parts of any casting or forging of high tensile steel, without involving distortion and without destroying the effects of the usual heat treatment to which the whole casting or

forging may have been subjected, has been perfected. The equipment usually supplied for oxy-acetylene welding is used, four sizes of burners meeting all requirements. The work to be hardened locally, is placed on a tank of water with adjustable overflow, so that the water level can be regulated, as while the portion of the surface being hardened is instantly heated to the required temperature, the whole of the remainder of the article is kept as cool as possible by being immersed in water. Should the immersion method not be possible, the part not being hardened must be kept cool by water flowing over the surface. The burner is held so that the outer portions of the flame flow in the direction along which the burner is travelling, and the portion of the steel heated should be cooled, when intense hardness is desired, by arranging that cooling water shall flow as close as possible to the traveling burner, but not so close as to disturb the flame, because that is not only liable to put it out but prevents rapid heating, and causes irregular hardening. The flame required should be of the highest possible temperature and burn close to, or even under water, this high temperature being obtained by adjusting the flame as for welding, and then increasing the pressure of the oxygen so that the flame changes color and appearance from a white cone to a bluish streaked tongue, when observed through smoked glasses. In this method the essential to success is the speed of the heating; as the flame passes along, the surface is instantly cooled by the cold body of the remainder of the forging or casting, leaving it at the maximum hardness of which the steel is capable when heated and quenched in cold water.

To obtain a thin but intensely hard surface, the part to be hardened should be just below the surface of the water, the impinging flame blowing the film of water away. The normal depth of hardening is about $1/16$ in., but a greater depth, up to $1/8$ or $3/16$ in., can be obtained by slightly prolonging the heating. A slight wavy or rotary movement should be given to the flame to avoid burning the surface of the steel. Contrary to what might have been expected, even with the hardest steels, there is no tendency of the hardened surface to crack or flake away from the unhardened portion. In a number of cases made for examination, not a single instance shows any parting between the hardened and the unhardened portions. While the process in the above case is applied only to high tensile steels, it is of interest to engineers to note that cast iron and black heart malleable iron castings can also be given a glass hard surface by hardening in this manner with the oxy-acetylene process.

Stellite and the Field Opened to It by Oxy-Acetylene

This wonderful high speed tool metal (which the manufacturers claim is "not a steel but its master," and which will cut out 25 to 300 per cent. faster than the best high speed steel, is so hard that it cannot be forged and will cut as well

when red hot as when cold), had one very serious disadvantage, which very considerably retarded its more general adoption; this disadvantage was its brittleness, which generally prevented stellite being used in the solid tool form, but necessitated its use in a tool holder. Apart from the general objections to tool holders that are well known, this method of using stellite was only partially successful, as even with the best designed tool holders, it was impossible to support the metal right up to the cutting edge, with the result that any slight jar, or an extra hard spot encountered, the stellite would break away through want of sufficient supporting. The tool holder was supplanted to a certain extent by using electric welded tipped tools, but as is subsequently pointed out, electric welding is limited to certain straight work of predetermined section, and consequently this did not overcome the difficulty to any great extent.

Stellite can, however, be worked with perfect ease, with no limitation as to size or shape, under the oxy-acetylene blowpipe. An oxy-acetylene stellite built tool gives an ideal tool, presenting the extremely hard cutting qualities of the

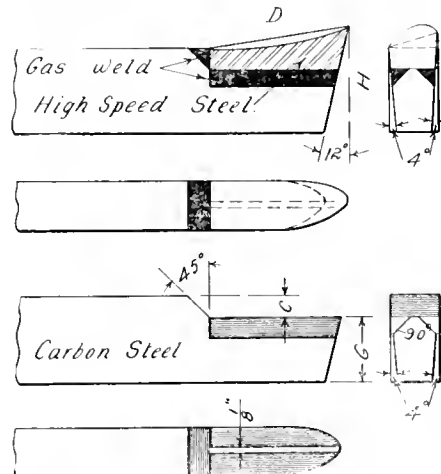

FIG. 4. PREPARING TOOLS FOR WELDING.

stellite, with the absence of tempering and minimum of grinding; supported homogeneously on a low grade steel shank which will withstand the severest shocks and has the same hardening adaptability and heat radiating features of a solid tool. The method of tipping is different to the welding of high speed steel, in this respect, that no previously prepared tip is needed, but the stellite is used in the form of a filling in rod and fused direct on to the shank, which has been pre-heated in the ordinary way; $3/8$ in. stellite rod has been found to give the best results. This method of facing has the particular advantage that any form or shape of tool or cutter, can have the cutting edge lined with stellite. Fig. 1 shows a very interesting example of this work. The cutter in question was an ordinary rough cutter for boring 6 in. high explosive shells; it was machined on the cutting edges $1/4$ in. wide and $1/16$ in. deep, and then built up with stellite, ground and put into service, and up to the time of writing it had bored 119 shells without any further grinding, and was still in good condition. A stel-

lite tipped rough turning tool turned sixty shells with only one grinding of the tool. Small ordinary circular tools for facing shell base plates, tipped with stellite, gave equally good results, and in no case of the tool under test did the stellite come away from the shank of the holder, when fused on by the oxy-acetylene process.

Welding High Speed Steel

It is perhaps in the field of welding high speed steel tips to carbon steel shanks that the greatest saving can be effected; with the present price of high speed steel at \$3 per pound, a tool for ordinary heavy work of $1\frac{1}{2}$ inch section, would weigh approximately 9 pounds, and would cost, without any labor charges for forging, etc., about \$27. The relative cost of a tipped tool using $1/2$ pound of high speed steel at \$1.50, and $8\frac{1}{2}$ pounds of carbon steel shank at \$1.02 (12 cents per pound), giving a total cost of \$2.52. It will be found in actual practice that the cost given for the tipped tool is excessive, as the high speed tips are made up from short pieces of steel, broken cutters, etc., which have only a market value of scrap steel, and the shanks, except in the case of very large users, are pieces reclaimed from the scrap pile.

There are three methods in general use of welding these tips: (a) by means of welding flux; (b) by the electric process, and (c) by the oxy-acetylene process. The first method has been adopted in a number of shops with varying degrees of success, due largely to the fact that each engineer has his own ideas as to the ingredients of the flux. A patent has, however, recently been granted covering a specific flux; but irrespective of the kind of flux used, its field of operation is strictly limited. In the second method, that of electric welding, the limitations refer more particularly to the capital outlay necessary, which prevents the system being adopted in any but large plants where welding work is continuous. Also, the preparation of the tools in electric welding has to be carefully thought out, for it is essential in making a butt weld that the cross sectional area of the two pieces be equal. This entails considerable loss of time and material in grinding the necessary clearance. To illustrate: Fig. 2 shows a tool that has the necessary clearance for use, but which it would be practically impossible to weld electrically, while Fig. 3 shows one that is correct for electrical welding, but would require considerable grinding for use. These welding limitations do not apply to either flux or oxy-acetylene welding.

It must also be remembered that with the electric process, the heat is bound to be concentrated upon the point to be welded, and no local annealing of the metal around the weld is possible, as is the case when gases are employed. This question of local annealing is one of vital importance. There are, of course, certain classes of work for which electric welding is the most suitable method to employ, but in general, a gas welding plant is better and more adapted to general workshop use.

The third method, oxy-acetylene welding, has no limitations outside the skill of the operator. Tips can be welded on irrespective of their size or shape; broken cutters can be welded together, or additional metal can be used to fill up the gaps, etc. In a perfect weld, the union of the two pieces should present the same chemical composition and phy-

the welding bench and the steel tip placed in position and tacked; that is, attached to the shank with a small piece from the welding rod. The tool should then be turned on each side successively and welded in on the space left by the beveling, to the uniform surface of the tool, care being exercised at all times to avoid playing the flame too long in the

are comparatively easy to weld, and therefore will not be of so much interest as the following examples, which demonstrate that the oxy-acetylene process occupies a field entirely its own, doing work that cannot be done by any of the other welding processes.

Circular tools are used for various kinds of profile work, and their delicate construction often results in cracking or breaking when being hardened or defects may develop after being put into service. In Fig. 6 are shown several of these tools that have been effectively reclaimed after breaking. They are 1½ in. outside dia., 4 ins. long, with a 9/16 in. hole drilled through the centre; the sizes given are of course not standard, as they have to conform to the particulars of the tool box in which they are being held. (A) shows a tool which was broken in three parts, evidently due to over heating or hardening. It was welded up, using high speed steel as a filler, afterwards heat treated and rehardened, and then put into service; after three days of continuous work (day and night shift), during which time it was reground as necessary, it showed no defects at all and could not be distinguished from a new solid tool. At (B) is shown the same type of tool beveled at the edges on the grinding wheel ready for welding. At (C) is shown one with a chip broken out of the side, ready for filling up, and (D) one that was worn too short to be properly held in the tool post, being welded on to a carbon steel shank of exactly the same dimensions and construction.

Every engineer knows the difficulty and expense in keeping flat boring cutters up to standard dimensions. They are generally made in two sizes, finishing and roughing, the general practice being to make them to the finished size, and when too small for this purpose regrind them for the roughing operation. It is also known that the life of these cutters is very short and erratic; sometimes they will strike a hard spot in the steel being worked, and burn, leaving a gap that very often destroys the cutter altogether, for by the time the gap is ground out it is too small for a rougher. In other cases the cutter cracks through or a piece will break off, thus destroying the

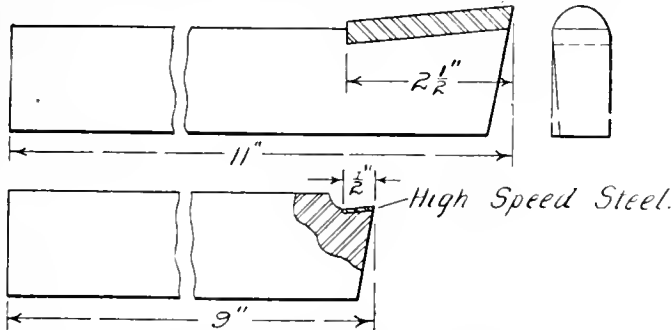

FIG. 5. LATHE TOOL WITH WELDED TIP.

sical characteristics as the jointed surfaces. Under these conditions the entire joint possesses a homogeneous structure and no variation in the mechanical properties should be disclosed in the different portions. This is where the oxy-acetylene process is distinctly in advance of any other at present in general use. It uses as a filler, metal of exactly the same chemical composition as the parts to be welded, and when combined with this is an advantage of welding any shape or size of tool with equal ease, it can be more fully appreciated why a gas plant for general workshop use, is better and more adaptable.

Preparing Tools

The general practice adopted for repairing or tipping lathe, planer, or other metal cutting tools is to bevel the shank as shown in Fig. 4. The lower view shows the shank prepared for welding, and the upper view the appearance of the tool after the weld has been made. This can be done most economically by the blacksmith when forging; the tips should also be cut by the smith to the approximate shape, to save grinding as much as possible, and also with a view to utilizing all odd and small pieces of the more expensive grade of steel.

Pre-heating

With the object of avoiding as much as possible, the interior oxidation of high carbon steels, it is good practice after the shank and tip have been prepared, to heat before welding, and to weld with a powerful blowpipe, reducing the time of welding to the minimum, thus obtaining a more homogeneous weld. Pre-heating should be arrested at a red heat, which permits of a regular execution of the weld by avoiding local overheating, the interior oxidation being less intense and the work more rapidly performed. At all times, it is advisable to reduce as much as possible, the interval between the commencement and completion of the fusion.

Welding

The shank and tip having been pre-heated, the former should be placed on

one spot, as this has a tendency to burn the metal.

Filling Material

The welding material used for welding high speed steels, to carbon steel shanks, may be either Swedish iron or vanadium steel rods, the latter giving the best results of the two. In special cases, such as welding a broken cutter or filling up a gap on the cutting edge of a boring cutter or drill, steel of the same quality as the defective tool should be used.

Heat Treatment

A point that many manufacturers overlook, is the physical properties of high speed steel and ordinary tool steel; these are so different that strains are set up by welding, unless the pieces are heat treated before they have a chance to cool down from the welding heat. Therefore, to obtain the greatest efficiency, a furnace should be near the welding bench, where heat treatment can be accomplished; in general practice, where the life of the tool is of short duration, the tool is not treated in the furnace, but buried in lime or asbestos as soon as welded.

Examples of Oxy-Acetylene Welded Tools

Straight tipped tools are used in very large numbers and actual working experi-

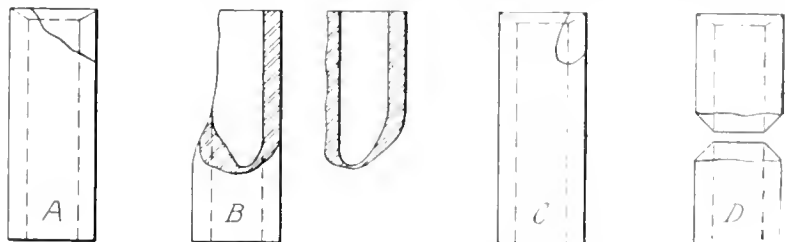

FIG. 6. PROFILING CUTTERS REPAIRED.

ence has shown that they are equal in every respect to solid tools, and when properly welded and hardened, the tips wear to the last small piece. Fig. 5 shows one of these tools, (a) shows the tool used for rough turning, tipped ready for use, and (b) shows the condition of the same tool when it came out of the machine shop for retipping. These tools

tool unless some satisfactory means can be used for reclaiming the same. These cutters can, of course, be machined down to form smaller cutters for other work, but the initial cost of the original machining has been lost, and most manufacturers will be able to estimate what this loss represents in their own business. In Fig. 7 is shown several flat

boring cutters that have been successfully reclaimed from the scrap pile; (A) illustrates a cutter that had a gap on one of the cutting edges, as indicated by the dotted line, which was filled in with steel of the same grade as that of the cutter with excellent results, making the cutter as good as new. At (B) is shown a similar cutter that was broken, with the pieces ready for welding, and (C) shows another cutter where the broken part was lost. This cutter was successfully built up to its original size with added steel of the same grade.

The size or shape of cutter or tool, or the nature of the break, makes no difference whatever to the process, for, as stated previously, the only limitation is the skill of the operator. Examples like the foregoing could be given in indefinite numbers, but each one would only be a repetition of the fact that an oxy-acetylene plant in the tool room, is not a luxury but a stern necessity.

Operation

Despite the fact that welding work generally is now on a more scientific basis than formerly, along with the ease with which an oxy-acetylene plant can be handled, so much so, that sufficient

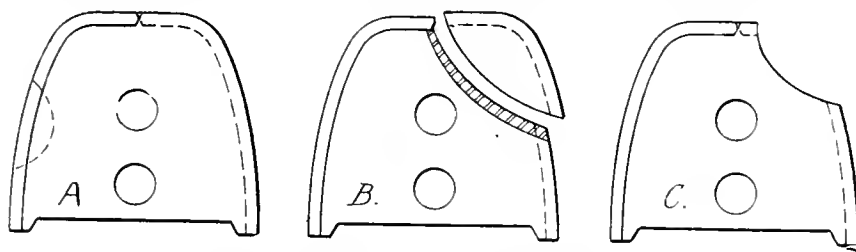

FIG. 7. REPAIRS TO FLAT BORING CUTTERS.

knowledge may be acquired in one or two days to enable a man to turn out useful and profitable work, the successful attainment of high skill in welding is still a difficult matter and considerable practice and concentration is essential to become perfect in the proper manipulation of the blowpipe. It should be borne in mind that there must necessarily be different grades of welding operators in exactly the same sense as there are different grades of tool makers, machinists, etc., as perfection is more a human than a mechanical factor. Indeed the ease of handling the oxy-acetylene torch has been one of the ever recurring difficulties that manufacturers of the apparatus have had to contend with. In the ordinary course of tool room work, when a difficult or intricate tool or jig has to be made, the foreman generally picks out one of the best men to do the job, and in case of failure, the cause is thoroughly investigated and the blame apportioned accordingly; but with the oxy-acetylene process, sentence is invariably passed without any investigation, and the general verdict is, "It is no good for that kind of work." This summary treatment is due, in a great measure, to the lack of knowledge of welding principles, not only on the part of operators, but also on the part of their foreman.

It is not to be understood from these remarks that a number of welding operators are necessary, but in handling work

of a specific nature, a man should be trained who understands the nature of the material he has to handle in tool work, cutters, etc., such as described in this article; a good tool blacksmith or a man skilled in tool tempering is the ideal material from which to obtain the best results.



SMOKE PREVENTION

THERE has been considerable agitation against smoke emission, and in all important cities smoke-prevention departments have been formed and laws made against smoke emission. The objections to smoke, as stated, are "public nuisance" and "fuel loss." The methods employed by smoke departments are effective in preventing the first, but the value of some of them as to the second is very doubtful. It is well known that the chief loss in a boiler plant is due to excess air (low CO_2), and not due to incomplete combustion, of which the result might be smoke.

To prevent smoke effectively, it is necessary to centre attention on the quantity of air used to burn the coal and keeping it down to a minimum, proper

the simplest literature could be obtained, describing the economical process of firing, and this written in an interesting way. It is not meant that there is no such literature, for an immense amount of good has been done by different journals of this character, but the man who needs it most does not get it, and it would pay to bring it to him.

The U. S. Bureau of Mines would increase its usefulness by including in its excellent editions on fuel technology from time to time, bulletins of a thoroughly practical nature especially adapted to the average boiler-room man. These bulletins should be written by men who know the fireman and who have been through the mill themselves. After such bulletins are ready they should not be kept until those who need them write for them, but they should be given a forced circulation with the aid of boiler-insurance companies, smoke-inspection departments, business men's leagues, etc.



POWER PLANT OPERATION AND MANAGEMENT

TO obtain the greatest efficiency possible in a power plant is not only a matter of design, but a good deal a matter of proper operation and management. Most power plants could make large savings in this way, and there are exceptionally few where some improvements could not be made without spending a dollar for new equipment. To obtain full benefit from the equipment on hand, the men operating it must be made more efficient, and this can be done by education, strict supervision, pay according to merits (bonus system), competition and advancement, welfare.

Education, while the most important, is also the most neglected factor in economic operation of a power plant. This is especially true in the boiler room where the waste is greatest. Skilled labor should be employed. Ordinarily, anyone is hired who will work for low wages and maintain the steam pressure. Every boiler room should have a man with authority to give orders and with sufficient personality to have his orders respected. This man should predetermine by the proper use of various instruments, the most economical ways of burning coal and instruct the firemen as to the best methods, and then insist that these methods be carried out.

Jointly with extending the license laws and making examinations more strict, opportunity should be offered to men intending to become operating engineers to acquire the necessary knowledge. While the practical part can be learned in the power plant directly, the fundamentals of theory which are all important to the up-to-date operating engineer are difficult to obtain properly. Co-operation of educational institutions is needed by the forming of classes at the various universities and other schools to give courses on economic operation of power plants. Instruction should be given by correspondence to those unable to attend in person.

furnace temperature and possibilities for well mixing the combustible gases and the air. At present (with exceptions), most attention is paid to smoke and smoke alone, without paying the attention to excess air loss that it deserves. As a result many plants are wasting more fuel since operating smokelessly than before, because of using more excess air. Smoke-prevention departments could greatly aid in preventing national fuel waste and some of them are doing so, but where they are not it can be laid to:—

(a) Political influence and interference.

(b) Lack of funds to employ expert inspectors.

(c) Employment of methods having no scientific basis and lack of effort to educate the engineer and firemen, while at the same time more force is employed than is good for the cause.

(d) Lack of confidence on the part of the power plant owner because of all of the above.

Exceedingly few firemen, not even 3 per cent., know the simplest rudiments of combustion. Many who are considered good firemen persist in operating their furnaces so that at least 20 per cent. of the fuel is wasted; at the same time claiming that it is the better and proper way. To overcome such conditions they must be educated.

It would be a great help if more of

Suggestions on the Standardization of Machine Tools*

By Carl G. Barth

The article deals in turn with the subjects of standardization of the machine equipment of a shop as a whole, standard speed series, standard feed series, the power of machine tools, tool posts for lathes, lathe centers, T-slots, lathe centres, drill-press and milling-machine sockets. The object is to encourage machine tool builders to adopt certain standards.

WHILE engineers and manufacturers are realizing more and more the desirability—yes, necessity, for standardizing, not only their own individual methods and product, but also to some extent the methods and product of each group engaged in the same line of manufacture; and while encouraging progress is being made by associations of manufacturers of such modern products as automobiles, electric motors and lighting apparatus, and no doubt by other associations of which the writer has no personal knowledge, little, if anything, has been accomplished by the machine-tool builders of this country.

Objection to Standards

Before proceeding to any definite recommendations, it will be well to con-

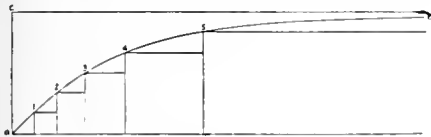

FIG. 1. CONTINUOUS vs. STEP BY STEP DEVELOPMENT.

sider the objection so often raised to the adoption of standards of any kind—that standardization blocks the way for further development and improvement. If this were unqualifiedly true, standardization would almost be a crime; but if we adopt a standard merely as representative of the best a trade or profession knows of at any one time, with the understanding that as soon as a decided improvement is brought out, a new standard will be adopted to parallel temporarily and eventually replace the former standard, the danger of stagnation will be obviated.

Perhaps my idea will be understood more readily by reference to Fig. 1, in

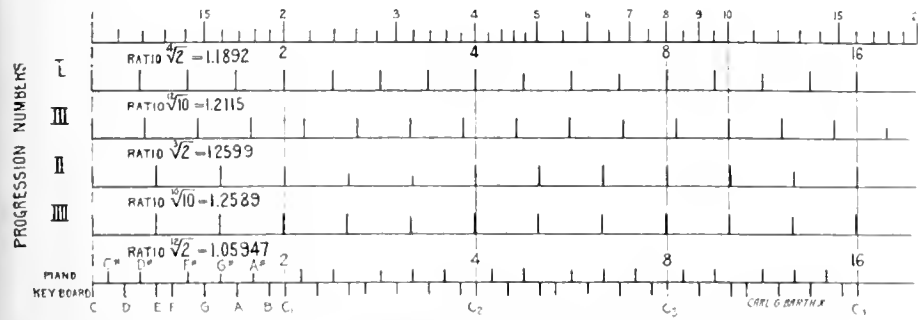

FIG. 2. LOGARITHMIC PLOT OF SUGGESTED ALTERNATIVE STANDARDS FOR SPEEDS AND FEEDS.

which the smooth curve ab tending towards the asymptote cd represents a gradual development with immediate

adoption of improvements in any line towards an eventual highest possible attainment, and the broken line whose corners 1, 2, 3, 4 and 5 lie in this curve the

sufficiently behindhand to be discarded and replaced for years to come.

During many years of experience, the writer has gradually been forced to see

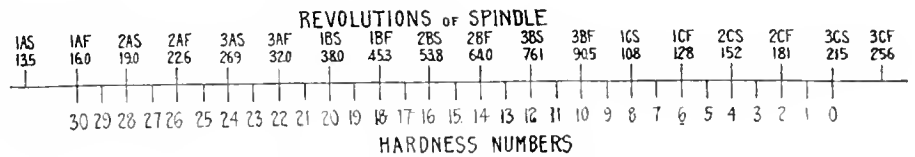

FIG. 3. LOGARITHMIC PLOT OF REVOLUTIONS OF SPINDLE AGAINST HARDNESS NUMBERS.

only occasional adoption of such improvements; when these have attained enough importance to make it worth while to change from one temporary standard to a new one, both standards are in use during the period of change. Such a period will, to be sure, seem exceedingly inconvenient after we have once tasted of the fruits that the use of standards bring forth, but it will be as nothing compared with the troubles and expense of dealing with a lot of unstandardized equipment all the time. "Where ignorance is bliss, 'tis folly to be wise," surely does not hold good in these matters.

an enormous advantage in also standardizing the machine equipment as a whole, aside from the standardization of the mathematical and certain constructive features of each machine. Wherever possible his effort is to have only the very same make of machines in a certain productive group, and in the expansion of such a group to add machines of exactly the same design, even to the extent of having a manufacturer furnish what is no longer his most recent product—only, however, if this or some other manufacturer's most recent product is not a sufficient improvement over the old to warrant the introduction of a new ma-

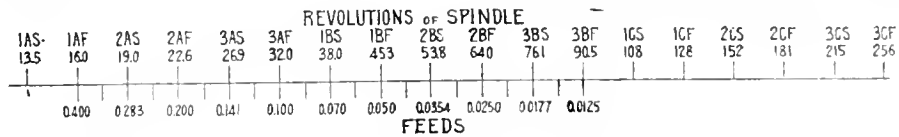

FIG. 4. LOGARITHMIC PLOT OF REVOLUTIONS OF SPINDLE AGAINST FEEDS.

Standardization of Machine Shop Equipment as a Whole

By this illustration I have particularly in mind the exceedingly one-sided manner in which most users of machine tools try to get the most up-to-date and best (if those users are not the kind that

chine as a new standard for the work to be done, with the intention that this type will eventually crowd out and replace the older type.

As an encouraging example of this, the writer recently had the satisfaction of seeing a newly-acquired client award the contract for a dozen large milling machines to one bidder, while the original intention had been to divide the order between two or more bidders, in order to obtain quicker deliveries as the paramount consideration.

Standard Speed Series

As in the present state of the science and the art of cutting metals, it is, on the average, impossible to determine the most economical or suitable speed and feed at which to run a machine for any set of conditions closer than a certain percentage. It is by this time universally accepted by those who have a right to an opinion in the matter that the available speeds of a machine should be in a geometrical progression. A discussion of this will not be undertaken by the writer unless provoked by some one else, though even at a recent date the futile attempts of some designers to arrange a series of

simply allow an unaided and ill-advised purchasing agent to buy on price alone), whenever they have to add to their equipment, regardless of whether or not the most up-to-date machine of a kind fits in with older equipment that will not be

*From a paper before the annual meeting of the American Society of Mechanical Engineers in New York City.

speeds in a geometrical progression are conspicuous. The reason for this is that a number of our machine-tool builders, while strong men of inventive genius or business ability who have worked their way to the front from the shop, have

the theoretical value of close speed regulation, though at that time the prevailing style of shop management, or rather lack of shop management, throughout the country was such that this knowledge was undoubtedly of no

10.70, 12.84, 15.41, 18.49, 22.19, 26.62, 31.95, 38.34, 46.00, etc.

Progression—I.

In reality, therefore, we will have a simpler progression by slightly modifying this ratio 1.2 such that the fifth term becomes 2 instead of 1.2⁵ = 2.074, for then the whole progression becomes 1, 2^{1/4}, 2^{1/2}, 2^{3/4}, 2, 2^{2 1/4}, 2^{2 1/2}, 2^{2 3/4}, 4, 4^{2 1/4}, 4^{2 1/2}, 4^{2 3/4}, 8, etc., or 1, 1.892, 1.4142, 1.6818, 2, 2.3784, 2.8284, 3.3636, 4, 4.7568, 5.6569, 6.7272, 8, etc., with every fourth term a power of 2, the simplest of all numbers except unity itself. The above fractions, as also in subsequent progressions, denote the power which the integer is raised.

This is, to the writer, an exceedingly attractive progression, and represents his ideal for some six years past, particularly as he cannot help comparing the revolutions of a rotating spindle with the vibrations of a musical string. In a piano, for instance, the number of vibrations of the strings also forms a geometrical progression with 2 as a constantly recurring factor, namely, as the ratio between strings that sound notes on octave apart.

never acquired sufficient theoretical engineering training to appreciate the mathematical problems involved, fundamentally simple though they are, and usually employ draftsmen and designers equally deficient along their line, many of whom, on the other hand, display ingenuity in their work that is little short of marvellous.

It being first agreed that a geometrical series of speeds should be provided for any one machine, the writer's idea is that a universal speed series should be adopted by all machine-tool builders for all machines, such as lathes, boring mills, milling machines, drill presses, etc., that are provided with a spindle for either the work or the cutting tool, and which, except in the case of certain single-purpose machines not included in this discussion, may be rotated at different speeds; for our present knowledge does not warrant us in asserting or assuming that a progression of speeds for one kind of these machines should have a lesser or a greater constant ratio than for any other kind; and, evidently, if there is no reason for making them different, there is every reason for making them just alike. The question then becomes, what should be the constant ratio of such a universal geometrical progression of speeds?

As far back as 1888 the writer designed for William Sellers & Co., Inc., of Philadelphia, a large lathe which had 30 speeds in a practically perfect geometrical progression, with a ratio of a little over 1.15, obtained by a correct relation between a 5-step cone, two back-gear reductions and two forward speeds of the countershaft. Again, in 1892, he designed another with 36 speeds which had

practical value to the operator, even in the shop of that company. In fact, when the writer finally got some real ideas about such matters during his first two years of association and co-operation with Mr. Taylor at the works of the Bethlehem Steel Co., immediately after Mr. Taylor and Mr. White had made the discovery of the high heat treatment of tungsten steels, the writer realized that

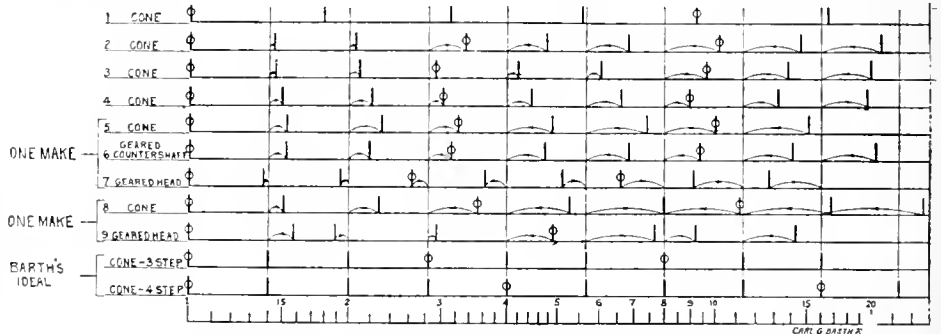

FIG. 7. LOGARITHMIC PLOT OF SINGLE COUNTERSHAFT SPEED SERIES OF NINE 16-INCH LATHES SUBMITTED BY VARIOUS MANUFACTURERS IN FEBRUARY, 1914.

he had overreached himself in those two lathes. Therefore, in designing some special lathes for the Bethlehem Steel Co. for the better utilization of the new high-speed tools, he adopted 1.2 as a more rational ideal, and he has never since found any reason for deviating materially from this ratio; though it was several years later before he recognized the desirability of an absolutely constant ratio, not only for all lathes, but, as referred to above, for all machine tools with a revolving spindle.

Because of this similarity, the writer, for lack of a better term, has named a series of speeds conforming to the above geometrical progression a chromatic speed series, though the term chromatic in connection with a musical scale has reference to the geometrical progression involved, rather than to the ratio 2 of the number of vibrations of two notes in an octave.

It may be, however, that the majority of machine-tool builders will consider the ratio $\sqrt[4]{2} = 1.1892$ unnecessarily small, and would deem a somewhat large ratio preferable in order to obtain a larger final ratio between the slowest and the fastest speeds of a machine which, for one consideration or other, may have to be arranged with a rather limited total number of speeds, as, for instance, a lathe with a single back-gear reduction, or a small drill press or milling machine with no back-gear reduction at all.

Progression—II.

The writer's answer is that he has had in mind also, as a possibly more generally acceptable progression, one with the constant ratio $\sqrt[3]{2} = 1.2599$; that is, 1, 2¹⁻³, 2²⁻³, 2, 2^{2 1-3}, 2^{2 2-3}, 4, 4^{2 1-3}, 4^{2 2-3}, 8, etc., or 1, 1.2599, 1.5874, 2, 2.5198, 3.1748, 4, 5.0397, 6.3496, 8, etc., which is as much entitled to the name chromatic as is progression I. In fact,

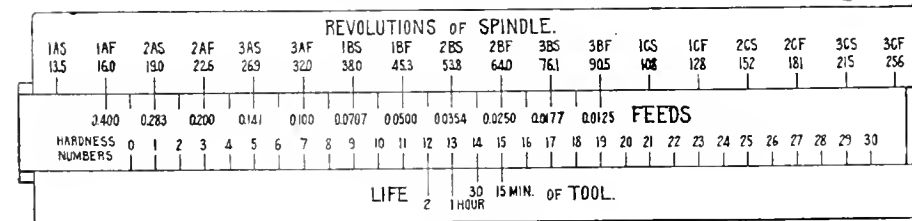

FIG. 6. SLIDE RULE DEVELOPED FROM FIG. 5 BY ADDITION OF LIFE RELATION OF TOOL.

a practically constant ratio of but little over 1.14, obtained by a 6-step cone, two back-gear reductions and two forward speeds of the countershaft.

These designs, only the latter of which was actually built, prove that this company was able long ago to appreciate

However, if we construct a geometric progression with this simple ratio 1.2, and beginning with 1, all subsequent terms of this will naturally be found to be anything but simple numbers, thus: 1, 1.2, 1.44, 1.728, 2.074, 2.488, 2.986, 3.583, 4.300, 5.160, 6.192, 7.430, 8.916,

in recently rebuilding eighteen vertical single-spindle drill presses for a client company, he made the speeds of these presses conform to this progression, in connection with a fixed gear reduction of

1, 10 1-0, 10 2-10, 10 3-10, 10 4-10, 10 5-10, 10 6-10, 10 7-10, 10 8-10, 10 9-10, 10, 10.10 1-16, etc., or 1, 1.2589, 1.5848, 1.9953, 2.5119, 3.1623, 3.981, 5.012, 6.310, 7.943, 10, 12.59, etc.

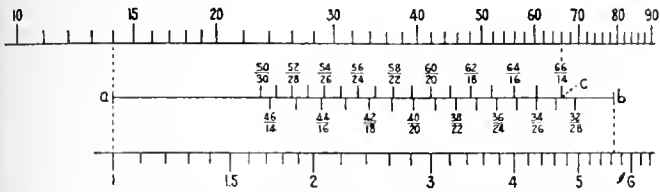

FIG. 8. SIMPLE LOGARITHMIC SCALE METHOD FOR GETTING THE CLOSEST POSSIBLE APPROXIMATION TO A GIVEN RATIO WHEN TWO SETS OF GEARS ARE INVOLVED.

3 to 1, a 3-step cone, and a 2-speed countershaft, thus giving them only six speeds in all. The presses had originally a back-gear reduction in addition to the fixed-gear reduction, a 4-step cone, and a single-speed countershaft, or eight speeds in all.

Progression—III.

Again, as a compromise between progressions I. and II., and to favor a possible preference for a progression with 10 rather than 2 as a periodically recurring ratio, the following progression may also be looked upon as a candidate:

1, 10 1-12, 10 2-12, 10 3-12, 10 4-12, 10 5-12, 10 6-12, 10 7-12, 10 8-12, 10 9-12, 10 10-12, 10 11-12, 10, 10.10-12, etc., or 1, 1.2115, 1.468, 1.778, 2.154, 2.610, 3.162, 3.831, 4.642, 5.623, 6.813, 8.254, 10, 12.115, etc.

The constant ratio of this progression $\sqrt[12]{10} = 1.2115$ is very close to the geometrical mean of the ratios of progressions I. and II., which is $\sqrt{2 \frac{1}{4} \cdot 2 \frac{1}{3}} = 2 \cdot 7 \cdot 24 = 1.224$.

Progression—IV. and V.

Finally, a certain interesting simplicity would also be introduced by the adoption of the constant ratio $\sqrt[10]{10} = 1.2589$, thus:

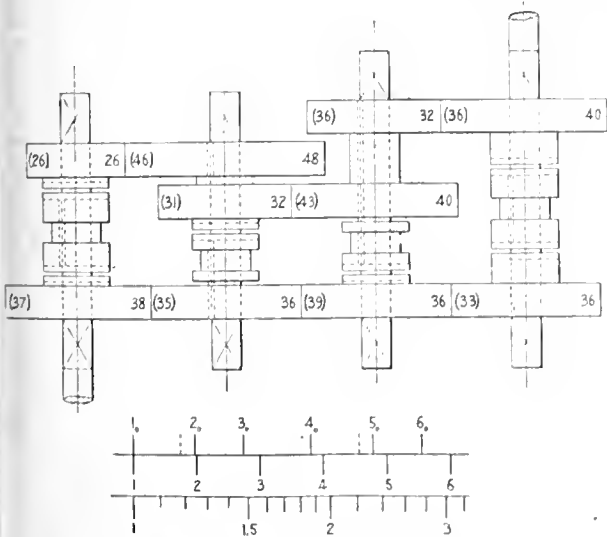

FIG. 9. DIAGRAM OF GEARING OF SPEED VARIATOR OF A WELL-KNOWN MAKE OF PLANER.

Figures in parenthesis show number of teeth in gears as made. Other figures show number of teeth in gears to improve the speed series. 10 to 60 logarithmic plot of original relative speeds. 1 to 6, logarithmic plot of improved relative speeds.

It will be noticed, however, that there is in reality a theoretical difference only between progression II. and this progression, the tenth number, 7.9431, of this being less than 0.8 of one per cent. smaller than the tenth number, 8, of the former. The best

comparison of these four progressions is, however, made by plotting them on a logarithmic scale, as in Fig.

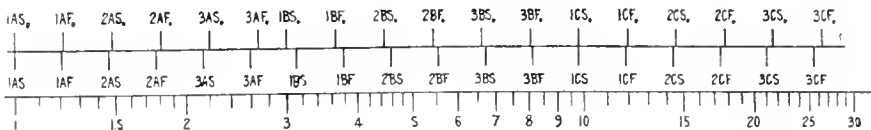
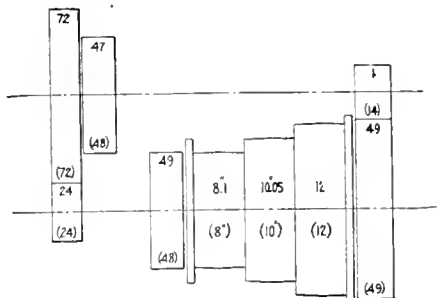

FIG. 10. DIAGRAM OF LIVE HEAD OF A WELL-KNOWN MAKE OF LATHE.

Figures in parentheses show respectively the number of teeth in the gears and the diameters of the cone pulleys as made; the other figures indicate a simple change that would further improved a very good series; 1ASo to 3CFo, logarithmic plot of original speeds; 1AS to 3CF, logarithmic plot of improved series.

2, on which is also plotted the progression that represents the relations between the number of vibrations of the strings of a piano, the constant ratio of which progression is $\sqrt[12]{1.05947}$. Having thus indicated that there may be a choice of standards, the writer will further on give some pretty strong reasons for favoring progression I., admitting at the same time that under certain conditions every other term may be omitted, thus leaving the progression:

1, $\sqrt{2}$, 2, $2\sqrt{2}$, 4, $4\sqrt{2}$, 8, $8\sqrt{2}$, 16, etc., or 1, 1.4142, 2, 2.8284, 4, 5.6568, 8, 11.3137, 16, etc.

Standard Feed Series

What has been said above in discussing the adoption of a standard speed series holds equally good for a standard feed series, except for the most up-to-date designs of lathes, in which the feeds for plain turning

are obtained as a constant fraction of the screw-cutting feeds. For these latter it is suggested that both the cross-feeds and the longitudinal feeds be made the same fraction of the screw-cutting feeds for all lathes regardless of size. Such an absurdity as a reputable manufacturing concern putting on the market at the same time a 20-in. lathe with this fraction about 0.25, and a 16-in. lathe with this fraction about 0.4, is indeed a severe indictment of the whole lack of system, both of designing and of buying machinery, that still prevails.

Progression—VI.

In paragraph 1134 of Mr. Taylor's "Art of Cutting Metals," the author gives his original classification of hardness of metals in terms of their relative cutting speeds, all other conditions being maintained uniform, thus: If 0 stands for the

ideally softest grade of any kind of metal, he made class 1 represent a metal just enough harder to reduce the cutting speed by 1.1; class 2 by 1.1²; class 3 by 1.1, etc., or by factors in the following geometrical progression:

Class 0, 1, 2, 3, 4, 5, 6, 7, 8, 9, 10, etc.: 1, 1.1, 1.21, 1.331, 1.464, 1.6105, 1.776, 1.949, 2.144, 2.358, 2.594.

The writer has since modified this to

Class 0, 1, 2, 3, 4, 5, 6, 7, 8, 9, 10, etc.: 1, 2^{1/8}, 2^{1/4}, 2^{3/8}, 2^{1/2}, 2^{5/8}, 2^{3/4}, 2^{7/8}, 2, 2.2^{1/8}, 2.2^{1/4}, etc., or 1, 1.0905, 1.1892, 1.2968, 1.4142, 1.5422, 1.6818, 1.8340, 2, 2.1810, 2.3781, etc., as being more rational, because then we have the great simplicity that a difference of eight hardness classes corresponds to a difference of exactly 2 to 1 in cutting speeds. It will be seen that this progression is just the same as progression I. with intermediate terms interpolated, hence the simplicity of this for a speed progression in conjunction with VI. for a hardness scale. It would mean that a tool would last just the same length of time on two materials two hardness classes apart, if run on the softer grade with a certain speed and upon the harder grade with the next slower; this is perhaps best brought out by the logarithmic plot in Fig. 3.

Again, in paragraph 732 of "On the Art of Cutting Metals," it is stated that, approximately, the cutting speed varies inversely as the square root of the feed,

we would increase or drop the feed by two steps at a time.

By combining the plots in Figs. 3 and 4, as done in the slide rule Fig. 5, we

the rule shown in Fig. 6. Thus, the further simplicity that for every change of one hardness class not accompanied by a change in feed or speed, or for a change

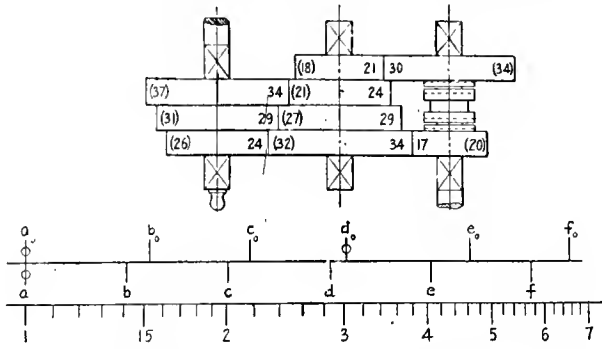

FIG. 11. DIAGRAM OF GEARS IN FEED BOX OF A WELL-KNOWN MAKE OF DRILL PRESS.

Figures in parentheses show number of teeth as made; other figures show improved number of teeth; a° to f° logarithmic plot of original feeds; a to f, logarithmic plot of improved relative feeds; these conform quite closely to progression (V), page 9.

which is a compromise between the special laws for steel and cast iron. Therefore, if in connection with a series of speeds conforming to progression I. we also have a series of feeds in the same progression, the relation of these feeds and speeds to each other will, in order to maintain all other conditions uniform, be as represented by the logarithmic plot in Fig. 4. Thus, for example, if 32 r.p.m. and 0.1 in. feed on a material of a certain hardness grade allow a tool to last a satisfactory length of time, this time would be practically maintained undisturbed if we increased the feed to 0.141 in. and dropped the speed simultaneously to 26.9 r.p.m., the depth of cut remaining the same; or, in general, in dropping or increasing the speed by a step at a time,

also most readily recognize that a change of one or more numbers in the hardness class of metal cut will have no effect on the cutting speed if we meet this with a change of feed involving a corresponding number of steps, increasing the speed as the hardness goes down, decreasing it as the hardness goes up. Finally, in paragraph 700 of "On the Art of Cutting Metals" is given the relation between cutting speed and the life of a tool in cutting steel, which is, that the speed varies inversely as the eighth root of the time the tool will last, all other conditions remaining uniform. Adding this relation to the slide rule in Fig. 5, we get

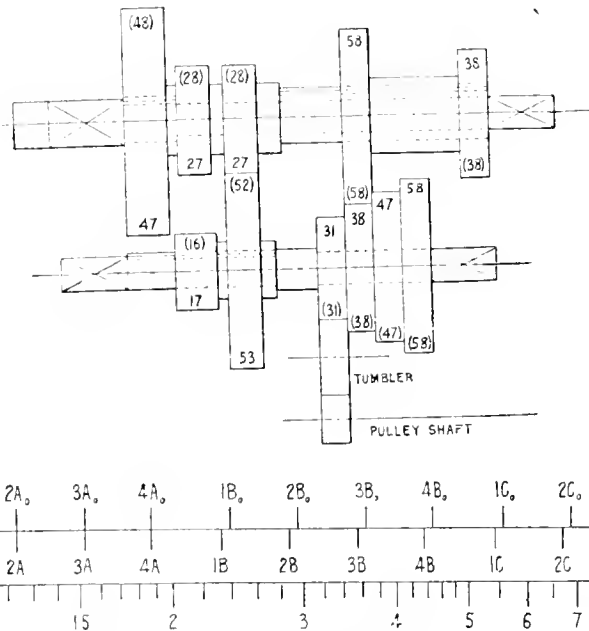
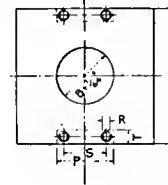

FIG. 12. DIAGRAM OF DRIVING GEAR OF A WELL-KNOWN MAKE OF MILLING MACHINE.

Figures in brackets show number of teeth in gears as made; other figures indicate number of teeth in gears to further improve an already excellent speed series; 1A° to 4C°, logarithmic plot of original speed series; 1A to 4C, logarithmic plot of improved speed series.



WIDTH OF TOOL - W	
POST	PLATE
A $W = \frac{1}{8}$	N $1\frac{1}{2}W + 1$
B $2\frac{1}{2}W + \frac{1}{2}$	P W
C $2\frac{1}{2}W + \frac{1}{2}$	R $\frac{3}{4}W + \frac{1}{4}$
D W	S $\frac{1}{2}W + \frac{1}{4}$
E $\frac{1}{2}W$	T $\frac{1}{2}W + \frac{1}{4}$
F $1\frac{1}{2}W + \frac{1}{2}$	SHIMS
G $\frac{1}{2}W + \frac{1}{4}$	W W
H $\frac{1}{2}W$	V $5W + 2$
J $3\frac{1}{2}W + \frac{1}{2}$	T $6\frac{1}{2}W + \frac{1}{2}$
X $3\frac{1}{2}W + \frac{1}{2}$	SET SCREW
WASHER	Y $3W + \frac{1}{2}$
K $3\frac{1}{2}W + \frac{1}{2}$	Z $3\frac{1}{2}W + \frac{1}{2}$
L $3\frac{1}{2}W + \frac{1}{2}$	
M W	

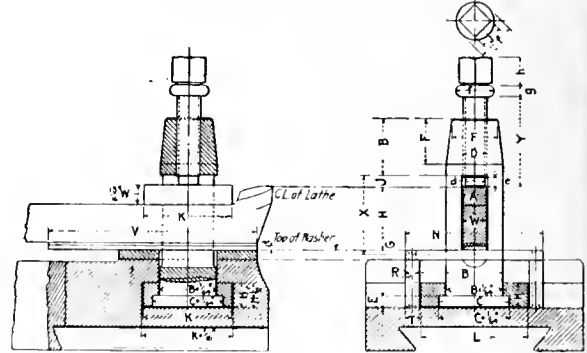

FIG. 13. PROPORTIONS USED BY AUTHOR FOR THE SWIVEL FORM OF TOOL POST FOR MODERATE-SIZED LATHES.

of feel from one step to the next, the life of the tool will be affected 2 to 1, in the one direction or the other, as the case may be.

The writer's preference for progression I. and his hope for its eventual universal adoption will now be fully understood by those who have already given some attention to the scientific control of machine utilization, and also by others who with an unbiased mind have tried to follow the arguments here advanced. A further argument is that this progression represents a fair average of the speed series provided by certain well-known machine-tool builders in some of the machines produced by them in recent years, after they had realized that the time had come for the provision of closer speed regulation, even if this meant a considerable reduction of the ratio of the fastest to the slowest speeds obtainable.

An example of this fact is represented in Fig. 7, which shows the speed ratios of nine 16-in. lathes offered by six different manufacturers in answer to an inquiry in February, 1914. One manufacturer offered three different designs and a second two different designs. It will be noted that the difference between the speed series provided in the different designs of the same maker differ as much among themselves as do the designs of different makers, except in the case of lathe No. 1, which represents the least up-to-date design. To make the diagram clearer, the speed ratios are laid out for a single forward countershaft speed only, thus showing only every other ratio of the full progression intended.

The objection previously considered, that the adoption of standards may to

which is for a tool body of approximately 1/30 of the swing of the lathe over the bed, and a distance from the centre of the lathe to the tool-supporting plate that corresponds to the ground height of the roughing tools shown in "On the Art of Cutting Metals." The propriety of these propositions is decidedly open to discussion, however, particularly the latter.

T-Slots

An exceedingly important part of the machine equipment of a shop are the T-slots in various machines, and the writer has also spent a great deal of money in bringing these to a standard, a matter that has at times meant entirely new face plates or tables for some machines. A great many years ago experiments were made by William Sellers & Co. to ascertain the strength of T-slots relatively to a T-headed bolt, and on the strength of these, that company adopted a standardized set of slots, which, as later modified by the writer, have also been used by him for several years past. They are shown in Fig. 14.

Lathe Centres, Drill Press and Milling Machine Sockets

The writer has also had to spend a great deal of money in standardizing lathe centres, and drill press and milling machine sockets, and ventures to suggest that the time has also come for the machine-tool builders to help this matter along. It is well known that the Morse standard sockets are no standards at all, but a perpetuated, laudable, although unsuccessful attempt of years ago to establish standards. However, compelled for the time being to accept them as they are, everybody has now at least two standard tapers for sockets and shanks to contend with, namely, the Morse and the Brown & Sharpe. The best the writer has been able to do, therefore, has been to make all lathe centres conform to a Morse standard, so as to enable drills or drill sockets to be directly inserted in either spindle of certain or all lathes in a shop; and to make all milling machine sockets conform to the Brown & Sharpe standard, with Morse drill sockets having Brown & Sharpe shanks for use with these whenever holes have to be drilled in a milling machine.

The writer unqualifiedly recommends the universal adoption of the Brown & Sharpe standards all around, and the use of Morse sockets with Brown and Sharpe shanks during the change. He also recommends the universal abandonment of the tang as a means of driving. We have for years had the ridiculous inconsistency of drill makers, that they still furnish taper-shank drills with the old-style tang as a means of driving and, along with this, extensively advertise and sell various forms of "use-them-up" sockets for drills with the original tang broken off. It puts me in mind of "Peer Gynt" in Ibsen's drama of the same name, when he manufactured and exported idols to China, and, to ease his conscience, also sent missionaries over there to convert the Chinese to Christianity.

More than twelve years ago the writer adopted a modification of the William

Sellers & Co. key method of driving as a substitute for the tang of drills, arbor and boring-bar shanks. This is illustrated in Fig. 15, and differs from the Sellers method in the use of a special form of key that has become somewhat known as the Barth key. The virtue of this as a means of driving consists of its being subjected to crushing pressures only, and that it has no tendency to work out of its seat. For a taper drill socket, it has the additional great advantage over the Sellers straight key that the drill shank can be inserted rapidly without any special care.



SPECIAL ALLOYS AND THEIR COMPOSITION

By L. E.

BY means of the aluminothermic process, metals are produced from their oxides in a practically pure state, free from carbon. Such metals have proved invaluable for a number of purposes, not the least of which is the making of non-ferrous alloys where iron and other impurities must be excluded, and the manufacture of which would be otherwise impossible. Among the most important of these metals are chromium, 98 to 99 per cent., and manganese, 96 to 97 per cent.; the former being chiefly and very extensively used in the manufacture of special high-grade crucible steels. The latter is mainly employed for making non-ferrous alloys, and one of the special features of this metal is the ease with which it alloys with copper, zinc, tin, aluminum, nickel, etc. Amongst other metals may be mentioned 75 per cent. ferro-chromium and 60 per cent. ferro-chrome-cobalt.

Improves Nickel Alloys

A small addition of manganese to nickel alloys has been found most beneficial, and gives a bright color resembling silver. For nickel castings manganese is used as a deoxidizing agent to produce greater density. In this case about 2 per cent. manganese is added to the molten nickel. In mints, manganese is added to copper-nickel alloys (25 to 7) to the extent of about 2 per cent. Manganese-copper with 30 per cent. Manganese, technically free from iron is now very largely used for a variety of purposes, such as in cupro-nickel, brass, and aluminum alloys, with far better results than an alloy containing iron. In aluminum alloys an addition of about 1 per cent. manganese in the form of 30 per cent. manganese copper is a good substitute for nickel or zinc. Such an addition increases the tensile strength, and gives a casting which can be more easily machined.

Copper and bronze castings lose their brittleness if manganese is added instead of phosphorus. Compared with other deoxidizing agents, such as phosphorus, manganese has the advantage that an excess will tend to improve the quality of the bath, whereas the excess of phosphorus would impair the quality. All castings with manganese alloys should be made under exclusion of air as far as possible. Generally speaking, it is better

to add manganese in the form of a high percentage manganese-copper, tin or zinc alloy as the case may be. Alloys of manganese-bronze, manganese-tin, and manganese-titanium, among others, are also made. The latter is said to be probably the best deoxidizing agent for brass and bronze alloys, only about one-third the quantity being necessary, compared with manganese-copper.

Recent Special Alloys

An alloy of ferro-copper 50 per cent. has recently been placed on the market. The alloy is absolutely uniform, in which state it can only be produced by the aluminothermic process, and is supplied in thin notched plates. For introducing vanadium and chromium into special mixtures, alloys of vanadium-copper 8 to 9 per cent. Va., and chromium-copper 10 per cent. Cr. are supplied. A special alloy for brass has also been recently introduced known as "SAB" alloy, which overcomes the difficulty experienced in getting manganese, tin, aluminum, iron, etc., to alloy by themselves with brass. The difficulty is generally got over by means of an intermediate alloy, such as ferro-zinc, for the purpose of introducing iron. These intermediate alloys, however, necessitate heating the brass to a high temperature which, in addition to causing a loss of zinc, has also the disadvantage of the alloy deteriorating in quality by absorbing oxygen in the form of zinc oxide. By means of the special brass addition, various elements in a definite percentage can be introduced into the copper and zinc bath. If 8 per cent. of the alloy is added to the brass containing 60 per cent. copper and 40 per cent. zinc, a brass will be obtained having a tensile strength of 33 tons per in. and elongation of 30 per cent. The product has a golden yellow color, and is distinguished by its resistance to atmospheric influences, to acid and alkaline solutions, as also to sea and mine water. It can be easily worked, forged and pressed. In order to make the special brass an alloy of 60 per cent. copper and 40 per cent. zinc is made from the purest copper and zinc, free from lead, and 16.5 pounds of the special alloy is added to every 204.6 pounds of brass; in doing this, the temperature must be kept so low that the brass bath only smokes.



WHAT is claimed to be the latest development in the uniflow engine consists in arranging the steam admission at the center instead of at the ends of the cylinder. This new design confines the heat to the central valve chest section; the cylinders which are single-acting have each a short, light piston which operates its own exhaust port.



AN interesting performance with oxy-acetylene apparatus recently consisted in cutting a steel disc die-block 14x18x36 in. into two pieces 14x16x18 in. The block weighed 2,382 lbs. and was cut with a Davis-Bournonville torch, style 3000, with a No. 5-8 tip. The cut was made in 9½ minutes, and the gas consumption was 325 cu. ft. of oxygen at 130 lbs. per sq. in. and 12 cu. ft. of acetylene.

EDITORIAL CORRESPONDENCE

Embracing the Further Discussion of Previously Published Articles, Inquiries for General Information, Observations and Suggestions—Your Co-operation is Invited

FOUNDRYMEN AND PRICE CUTTING

By "Cupola."

IF there is one question more vital to the foundryman than another it is the question of price-cutting. Other trades are beginning to see that the evil of price-cutting is ruinous to the foundryman. No less than any other line, and particularly to the jobbing foundryman. The manager of a large foundry, in speaking upon this subject, stated: "It just amounted to this. We had to buy over several specialties and acquire the sole manufacture of them, or close down. This expenditure meant thousands of dollars of new capital, scrapping a whole lot of accumulated equipment, of which there is no end in a jobbing shop."

There's no reason in the world why a jobbing foundry should not be a paying venture, and it is only a matter of time when such will be the case. All over the country foundries are doing as this manager stated, and if the jobbing foundryman will take advantage of the situation and demand a living price this evil of price-cutting will soon be a thing of the past.

Effect on the Moulder.

The evil of price-cutting has an effect upon the moulder which is detrimental. He hears that the boss took such a job at so much per lb. He figures it out in his own crude way something like this: "Well, wouldn't that skin yer! The boss has taken this job at so much per lb. Iron costs so much. It takes ten of us two hours to take off a cast. It takes Jimmy six hours a day to get the cupola and ladles ready, then he has coke, cores and losses. The castings have got to be rumbled, bagged and shipped. It will take us fellows all our time to put up so many boxes a day, because the castings only weigh so much a piece. That don't allow a cent for profit. I'll be darn'd if I know what he's thinking about. I'm not going to work like Sam Hill to make him money at that price."

The boss says: "But look here, chaps. I simply had to take the job to keep you fellows going. So & So offered to take it at ¼ of a cent less, but Brown's a friend of mine and I got the ¼ of a cent more."

The writer has been up against this "Friend of Mine," and is very pleased to say, has lost a lot of friends. Job said, "Lord preserve me from my friends." The moulder who knows that the boss is price-cutting is like the sailor who finds the captain boring a hole in the bottom of the ship to let the water out, and beginning to see that all the pump-

ing in the world won't save the ship, he refuses to pump any faster.

Back-Bone Wanted.

What is needed is better business methods, more back-bone "less friends," less of the "well if Smith can let you have them at 3 cents I can" kind of methods. There's not a foundryman on this earth that can give a price on a line of castings unless he has moulded the job before. Every casting has some peculiarity of its own. It depends upon how they're gated, or whether the castings have to be machined or not, and a thousand and one little things to be considered.

Before a price is given there should be a test made if there is any quantity; for a few tons, however, there should be no juggling of prices, but a straight time and material invoice rendered. There are buyers of castings to-day that do nothing but peddle their castings all over the country and pose as "friends of mine" to the limit, simply because they know that on an average the jobbing foundryman is a poor business man.

In this way foundrymen who, in actual fact, are the beginning of the mechanical world, are the poorest financially, of any of the allied craftsmen.

Can Buy Castings Cheaper.

It's a very common thing to hear the head of a large machinery company, when asked why they buy their castings instead of running a foundry to reply, "Run a foundry? Not on your life. We can buy castings cheaper than mould them and have no worry. If we get had castings it's not our loss; it's the other fellow's."

There are various reasons for this state of affairs. For instance, a contract has been taken to turn out castings at a certain price, and there is scarcely enough weight in a day's moulding to take off a melt. The foundryman thinks, "Now, if I could only get another

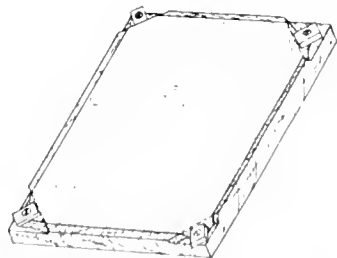

SERVICEABLE EMERY CLOTH BOARD.

job with a bit more weight in it, I could make good on this job." So out he goes looking for a bit more weight, and he's so anxious to get weight that price is a secondary consideration; thus possibly spoiling a customer and lowering a fair price, with the result that some day

he'll be handicapped with "more weight" than price. Buyers of castings begin to play upon the foundryman in more ways than one.

What Is Wanted.

Now, what is wanted is this. The foundryman should find out what it costs him to do business. He should say to himself, "Well, if I was working for So & So, he'd give me \$150 a month." and begin like this:

Overhead Expenses For One Year.	
Own salary, \$150 a month	\$1,800.00
Rent of foundry, \$25 a month	300.00
Telephone	45.00
Stationery and postage	25.00
Bookkeeper	600.00
Fire insurance	50.00
Laborer at \$2.50 a day, 300 days.....	750.00
Cupola man, \$3 a day	900.00
	\$4,470.00

An average of \$14.90 per day for 300 working days. And there are other little incidentals which creep in.

It may be stated that a laborer and cupola man need not be classed as an overhead expense, but both these men are just as indispensable as the boss. The writer was in a foundry not long ago and asked for the manager. He was told to go into the foundry. And there was the boss with his sleeves rolled up, working at a job which the laborer should have been doing. That was all that boss was worth, but he may have been drawing a couple of thousand dollars a year. This particular foundry was employing, on an average, 25 men all the year round, and not paying a dividend, just holding its own, and lucky at that.



SERVICEABLE EMERY CLOTH BOARD

By D. A. Hampson.

WHERE emery cloth is used to polish and burr off small parts, the sheets are generally tacked on a board or on the bench, or the corners weighted down. These are unsatisfactory ways at best, consuming much time in changing sheets and not presenting a solid, flat face. Then, too, the edges and corners are more or less blocked off and the sheet of cloth is worn in the centre, over little more than half its area. Such waste of cloth and time, spent on poorly done work, represents a decided loss.

A better way is to make up a set of emery "boards" either like the one illustrated, of wood or of cast iron. If of the latter, a section ¼ in. thick, ribbed all around with two centre cross ribs, makes a board light enough to carry around easily, and heavy enough to stay in place on a bench. The face should be planed.

If made of wood, well selected and thoroughly dried, the board will be ac-

curate and lasting. It is better to make the board of two thicknesses, with the grain crossed, as shown, nailed or screwed together, in preference to glue. The outstanding feature of the board, however, is its economy—the emery cloth being quickly changed and always drawn taut and nearly all of its surface available for unobstructed working. At the corners are metal clips which clamp the sheet and, by drawing against the bevel face of the cut-out corner, pull it flat without wrinkling it. The screws thread into nuts set in the under side of the board.

Unless carefully watched, workmen are prone to be wasteful of emery cloth, throwing away sheets which are but half used up, dirty, or useful for other purposes. Emery cloth can now be obtained in narrow rolls, which are more economical than the practice of tearing up strips. Emery cloth which is dirty can be brushed out with a stiff brush (even a file card will do) and its surface thereby renewed. When the work is oily or greasy, the cloth gets filled up and smooth very soon after put in service, but it is easily cleaned with kerosene and a soft bristle brush. For many purposes used emery cloth is better than new—the “scratch” is off—and sheets that are ordinarily thrown away, can be saved and used again. If dry and not torn, a used sheet of one grade is as good for service as a sheet of one or two grades finer.



GETTING THE MOST OUT OF A SAW

By H. Middleton.

A PATTERNMAKER can get along very nicely with no machinery other than a good saw bench if it is rigged up like the one in the illustration. A good all-metal saw is much to be preferred to one with a wooden frame. A new spindle, or saw arbor, is made with a projecting end that is externally threaded and is bored to take the taper shank of a drill chuck.

The external thread is left hand and on it screws a light cast iron disc, 8 in. in diameter, to which sand paper is glued. By means of an auxiliary table on the shelf at the side, support for the work

are legion and new ones are constantly presenting themselves.

When it is desired to drill holes, the disc is taken off and the drill chuck put in the spindle. Various face plates, side and angle gauges for odd drilling, are made of wood. This makes a low-priced, good, all-round outfit for a patternmaker. Complete with $\frac{3}{4}$ horse-power motor it should cost less than \$200, and is all any man with a small business needs.



WHAT IS “HARDNESS”?

By L. Street.

THE word “hardness,” as loosely used in everyday engineering talks, has no precise meaning. It calls up in the mind a complex image of a substance which is not easily scatched or dented, is liable to snap rather than bend, and will be likely to give trouble in machining and resist wear. “Hardness” is a utility word that carries all these associations. One can, however, use the word in a more definite sense, and speak of the hardness of a substance as determined by one or other of the hardness tests.

Such tests fall into two categories: (1) Abrasion or scratch tests, in which particles of the material whose hardness is to be determined are torn away from its surface by sliding contact with some other substance, whose corresponding resistance is so high that its surface remains unimpaired by the action! (2) indentation tests, in which the surface of the material under test is permanently distorted by the pressure of a hard steel ball, cone, or knife edge. Of these, the indentation tests are the simplest, and give very reliable indications of one of the component qualities of hardness—resistance by local deformation—which the method is best suited to determine; Brinell and scleroscope figures are, therefore, accordingly more often quoted as measure of hardness than any other test result. For this reason engineers have rather fallen into the way of regarding indentation figures as an accurate index of hardness in general, including the kind of hardness which ensures resistance to wear. As a matter of fact it does not by any means follow in practice that a metal which re-

plex of many characteristics which, so far as present knowledge goes, cannot be determined by any single test. The indentation test informs us of resistance to deformation; any one of the many possible abrasion tests will indicate resistance to wear under conditions similar to those obtaining at the test; but it is not possible to argue from one kind of the test what the qualities of the material will be under any other.

The Committee appointed by the Institutional Engineers in 1914 “to report on a hardness test for hardened journals and pins,” describes in its report an ingeniously contrived series of tests to determine resistance to rolling abrasion with a view of comparing the results of such tests with the Brinell and scleroscope hardness numbers. The conclusions reached, while distinctly informative in many ways, make it clear that the Brinell hardness numbers of a miscellaneous selection of steel are not a safe guide in predicting their relative resistance to wear.

Results Not Interchangeable

As an example of the difficulties that surround the task of finding a law whereby the results of hardness tests of various kinds might be interchangeable, the process of skin-hardening which goes on under wear with some grades of steel, more particularly manganese steel, is especially noteworthy. Manganese steel, though it cannot be tooled, is really quite “soft” material. Its prime quality is toughness; its hardness is only about 200 Brinell. As soon, however, as it is subjected to a crushing or rolling action, producing deformation, the skin of the surface takes on quite another structure, passing from 200 Brinell hardness to 300, or even 500. This is a peculiar property, and explains why it is so difficult to tool a steel of such comparative softness, the reason being that the material hardens to the pressure of the tool. For this reason alone hardness cannot be expressed in terms of single value. It can only be expressed, by a complete stress strain curve.



MECHANICS TRAINING COLLEGE

AN arrangement has been come to between the Amalgamated Society of Engineers and the local employers in the district of Dudley, England, which will greatly facilitate the founding and work of a training college for engineering mechanics. The principal object of the scheme is to enable boys engaged in workshops to improve not only their ordinary education, but acquire a proper grounding in mechanics, geometry, and mechanical drawing. The question of remuneration seemed to offer possible grounds of disagreement, but with the amicable settlement of this point the scheme is being proceeded with.

The college training begins at the age of 16, and on attaining the age of 18 the employee-student will continue his studies outside of working hours. It is also stipulated that class attendance will not affect the earnings of the pupil so far as factory conditions are concerned. The scale of payment is fixed till the student is 21 years of age.

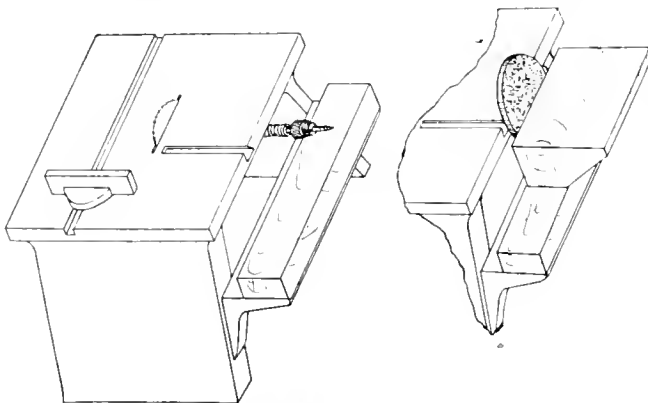

GETTING THE MOST OUT OF A SAW.

is provided across the centre of the wheel. Having no nut at the centre, the entire face is available for sanding patterns, rounding corners, putting on “draft,” etc. The uses of a sand wheel

sists indentation will in the same measure resist abrasion.

A Complex Characteristic

Hardness is not a specific property, like elasticity or tensile strength, but a com-

Uniform System of Foundry Cost Accounting

To promote the adoption of a uniform system of foundry cost accounting among its members, the American Foundrymen's Association has outlined a plan of procedure which represents the most comprehensive effort in this line of endeavor that has ever been undertaken.

FOR some years the American Foundrymen's Association has had had cost committees at work which have presented valuable reports at the annual meetings of this society, but unfortunately a large part of this work has been without practical results owing to the fact that the members, in only a few instances, have followed the recommendations made.

To make this work more practical and to facilitate the installation of uniform cost-keeping methods in the plants of the members of this association, it has been decided to provide them with the personal service of a cost expert whose duty it will be to make the existing cost systems conform to the one that is to be adopted. Without the services of a cost accountant to introduce the system, no headway can be made toward uniformity of practice, which is the underlying basis for intelligent estimating among competitors.

Since the American Foundrymen's Association, due to its low cost of membership, is without means to carry on this special work, it was decided to raise a fund by subscription among those who desire to participate in the benefits to be derived from this undertaking. The plan will enable foundrymen to obtain a cost accounting system at a nominal cost, which will be representative of the latest and best practice in cost-keeping methods.

Productive labor is a good measure of the value of the business transacted by a foundry and, therefore, the expense of this undertaking will be prorated on the basis of the number of molders and coremakers employed. The schedule of charges that will apply, follow: Foundries employing up to 40 molders and coremakers, \$50; from 40 to 200 molders and coremakers, \$125 for each molder and coremaker employed; for plants employing more than 200 molders and coremakers a flat charge of \$250 will be made. Since additional traveling expenses will be involved in the installation of the system outside of the industrial centers of the United States and Canada, an extra charge will be made for this service west of the Mississippi river, south of the Ohio river, and outside of the Province of Ontario, in Canada.

Payments are to be made on the following basis: Twenty-five per cent. when subscribing to this special fund; 25 per cent. upon the receipt of the book containing the uniform cost system; 25 per cent. after the system has been installed by the cost expert and the remaining 25 per cent. after the subscriber has received from the cost accountant a written report covering the system in use with suggestions to make

it conform to the uniform method to be adopted.

To carry on this work, the Cost Committee of the American Foundrymen's Association has engaged the services of C. E. Knoepfel & Co., New York, industrial engineers and cost accountants. Data are now being gathered preparatory to the compilation of a uniform system of cost-keeping for foundries, which can be adopted to shops specializing in the manufacture of gray or malleable iron, or steel castings. The problems of the foundry which is a department of a manufacturing plant and produces no castings for the trade will be considered and provision also will be made for specialty, light and heavy work shops.

When the uniform system has been ratified by the Cost Committee, it will be printed in pamphlet form and will be distributed among all of the subscribers. As soon as possible thereafter, cost experts in the employ of C. E. Knoepfel & Co., will visit each one of the plants of the subscribers and will point out the features of the cost system and will aid in its installation. This personal visit will be followed by a written report by the cost expert who will detail every step to be followed in the introduction and use of this system. For a reasonable time thereafter, the advice of C. E. Knoepfel & Co., can be had by correspondence without additional cost to the subscriber.

Subscribers to this fund are limited to the membership of the American Foundrymen's Association, but foundries not so enrolled can derive the benefit of this great work by becoming members of this organization.

Furthermore, only subscribers to this special fund will receive a copy of the uniform cost system and the services of C. E. Knoepfel & Co., membership in the American Foundrymen's Association alone not entitling those so enrolled to participate.

Favorable replies already have been received from 217 members of this organization in the United States and Canada, and 51 have forwarded their subscriptions. This is sufficient assurance that the plan can be carried to a successful conclusion, and it marks the beginning of the greatest uniform cost campaign ever undertaken in a single industry.

The members of the Cost Committee, who conceived this undertaking, follow: B. D. Fuller, chairman, Westinghouse Electric Mfg. Co., Cleveland; H. J. Koch, Fort Pitt Steel Casting Co., McKeesport, Pa.; J. Roy Tanner, Pittsburgh Valve Foundry & Construction Co., Pittsburg; C. R. Messinger, Sivyer difficulties confronting the Western pub-

Steel Coating Co., Milwaukee, and A. O. Backert, secretary Twelfth and Chestnut Streets Cleveland.

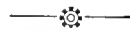

POWER FOR STEEL MILLS

FROM a report of the central station power committee of the Association of Iron and Steel Electrical Engineers, submitted at the recent meeting in Chicago, the following has been taken, and for which we are indebted to the *Iron Age*.

The rate schedule of 20 power companies furnishing power to steel mills has been obtained. To permit comparisons the net resultant rates for 1000-kw. and 5000-kw. loads at 50 per cent. load factor were calculated, which calculations gave the following results:

	NET RATES PER KW.-HR., 50 PER CENT. LOAD FACTOR.		
	Maximum	Minimum	Average
1000-kw. demand	1.246c	0.700c	0.9417c
5000-kw. demand	1.060c	0.667c	0.8464c

The demand, including the effect of power factor upon it, is just as important a part of a proper rate schedule as is the energy charge. A mill with a load factor of 70 per cent. and a power factor of 80 per cent. or better can be served at much less cost than a mill having a load factor of 35 per cent. and a power factor of 50 to 70 per cent.

Rate Schedule

Rate schedules should be as simple as possible and avoid complicated systems of rates and discounts for varied load factors and consumptions. Where the mill can so adjust its operations as to permit keeping off the central station peak there should be a lower rate than for peak service. Some of the power companies reporting charge only 50 per cent. of the peak demand rates for off-peak service only.

We recommend that in negotiations for central station power service, and in order to obtain most favorable rates to the purchaser, it be insisted that the rate schedule be divided into demand charges and energy charges; that the demand be the average or integrated peak of 15 to 30 min. duration; that the power factor be 80 per cent., with decrease or increase in the demand to be charged for accordingly as the power factor is above or below 80 per cent.; that the demand charges per kilowatt be in two or more steps; that the energy charges per kilowatt-hour be in two or more steps; that any excess demand occurring at other than the peak period of the power company's plant be charged at only one-half the demand charge normally applying for such excess if occurring on the power company's peak period. With rate schedules on the basis recommended, the mill engineer will obtain the benefits due to good operating conditions and not be obliged to pay for the poor conditions of another consumer's load.

The user of electric power is enabled to collect engineering data, such as capacity of machines, load curves, power requirements, maximum demands and

power consumption, and, in addition, to provide a means of analyzing the cycles of operation throughout the plant. With such records, the central station can accurately determine the requirements of steel mills and negotiations for the sale of power are greatly facilitated.

The power requirements in steel mills range from 1000 to 10,000 kw. or more. A fair average is about 4000 kw. The load is characterized by large peaks. Where alternating-current service is used the power factor will vary from approximately 65 to 80 per cent. Large generating capacity is required to provide service of the proper regulation.

Application of Central-Station Power

In all large modern central stations, the power is generated and transmitted as alternating current at a voltage considerably higher than is permissible for use around a plant. At the receiving end of the transmission line this power must be retransformed to at least two and generally three lower alternating-current voltages, namely; 6600 or 2200, 440 or 220, and 110; and, where direct-current power is used, further transformation is required from alternating current to direct current.

The 6600-volt or 2200-volt current is used for driving the synchronous motor of motor-generator sets, the large motors driving the mills and some of the larger auxiliaries, say from 100 hp. up for the 6600-volt and 50 hp. up for the 2200-volt for driving pumps, fans, blowers, etc., in those locations where these voltages can be used without endangering life and property.

For the remaining auxiliaries the alternating-current voltage is further reduced to 440 or 220 volts. Motors wound for these voltages have a wide range of application, covering almost all classes of service in the mill, especially where constant-speed characteristics are required.

For lighting 110-volt is generally used and transformed from either of the above voltages. In all of the above transformations a certain percentage of the initial purchased power is lost, the magnitude of the losses being in the order of the motor-generator sets first, the rotary converter second, and transformers third and least.

In some contracts for central-station power the power paid for is that which is delivered to the high-tension side of the transformers connected to the transmission lines, the power being measured on the low side of the transformers, the wattmeter readings on the low side being multiplied by a constant or multiplier which takes into account the transformer losses. In contracts of this class the purchaser pays for transformation losses. In other contracts the power paid for is that which is delivered on the low side of the stepdown transformers, the power company paying the losses of the first transformation, the purchaser paying for all others.

A study of percentage losses incurred in distributing central station power from receiving station to plant feeder

station busbars would indicate that in deciding on the other equipment that that equipment should be selected which would entail the least losses to the power delivered to the motors. If this was followed out without regard to other conditions we would select 6600 or 2200 volt apparatus; but physical and safety considerations limit the use of those voltages, and consequently only a relatively small number of the total motor equipment can use them.

Our next choice, so far as efficiency goes, would be for the 440 or 220 volt alternating-current auxiliaries. These can be used in almost all applications where direct-current power is used, the exceptions being where variable speed and dynamic braking are required. The direct-current motors are so much better adapted for this class of service that the disadvantage of greater conversion loss is more than compensated for by their flexibility and adaptability.

The ratio of alternating current to direct current used will vary greatly in different plants, depending on so many factors that no standard can be set. In general, in those plants where power is purchased and where there are many cranes and variable speed drives direct current will probably predominate for auxiliaries about in the ratio of 60 per cent. direct current to 40 per cent. alternating current for voltages of 440 alternating current or less and 250 direct current.

The alternating current is suitable for driving fans, pumps, hot saws, cold saws, conveyors, straightners, drill presses and possibly some mill tables. Alternating-current motors are not favored for table drives, for the majority of them require a wound rotor type of motor, which, as a rule, is more difficult to repair than a direct-current armature, and the direct current is better adapted to heavy table work. Direct current will be used for cranes, tables, charging storage batteries, electrolytic work and variable speed motors, especially those used for driving machine tools. The type of winding to use will depend on the nature of the load and the results sought.

In general, the use of alternating-current motors is recommended where constant-speed, non-reversing conditions obtain, and the direct current where large starting torque, quick-reversing and acceleration, variable speed or dynamic braking are required.

TURBINE GEAR LUBRICATION

By O. C.

WITH the increased use of geared drives there is an increased necessity for minimizing friction, thus reducing the wear and noise and increasing efficiency. The best results so far have been obtained with helical gearing, and the use of this has proved extremely advantageous in the case of turbine drives for marine purposes and for direct current generators. The latest types of double helical gears are, however, those which secure the best results, great accuracy being

combined with high efficiency and silent operations. The mounting of all gearing should have extra careful attention, especially as to the support of the pinion in high speed and high power work.

The lubrication of turbine gears is effected by means of special sprays arranged to deliver the oil direct on to the teeth, as to allow such gears to run partially submerged in an oil bath would absorb an appreciable amount of power. The pinions of turbine gears are usually of nickel steel, and the large wheels of cast iron with steel rims. To obtain quiet running, straight-cut rawhide, cambric and paper pinions are sometimes used; ordinary hydro-carbon oil, however, is most destructive to rawhide pinions, and the fact that rawhide pinions have gained a bad name is entirely due to the use of this lubricant. One of the best compounds for rawhide pinions is as follows:—

Plumbago	15%
Resin oil	55%
Resin	30%

Cloth and paper pinions can be lubricated without injury with ordinary oil.

UTILIZATION OF PEAT AS FUEL

By T. J.

UNTIL recently there has been no system in existence for the utilization of peat on a commercial basis; but a new invention, which recently reached the commercial stage, offers a means of supplementing the existing coal supply and in the meantime providing an ideal charcoal for the trenches. The whole trouble with regard to the utilization of peat has arisen from the difficulty of completely separating the moisture from the solids. It was this difficulty that all inventors had failed to overcome. The process here referred to, known as wet carbonizing, solves the problem. It is simple and works almost automatically. The peat is pumped from a bog into a reservoir, then fed into tubes, which are steam-jacketed and heated to such a high temperature that a complete chemical decomposition takes place in the peat, and the tiny cells are completely disintegrated; in other words, the water and peat become two distinct elements. The remaining process consists in pressing the water out and drying the peat powder before making it into briquettes. The briquettes contain a fair percentage of nitrogen, and are of a high calorific value.

INVESTIGATION shows, according to J. W. Powell, president of the Fore River Shipbuilding Corporation, that the average wages in shipbuilding in Great Britain are 50 per cent. less, and the net output per worker 14 per cent. higher than in American yards. In spite of the vast capital expenditure devoted to the improvements of the American shipbuilding plants during the past three years, which is believed to have placed them in the front rank from the view of equipment, the opinion is put forward that no superiority of design or methods of building can overcome the basic disadvantages of the American industry.

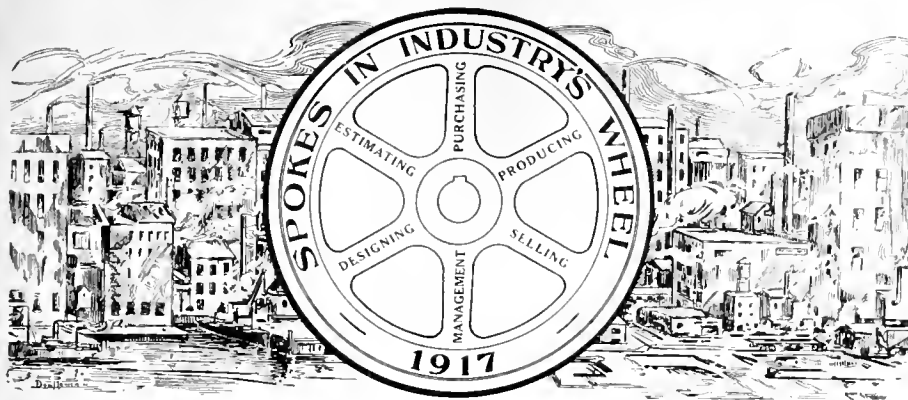

The constitution of industrial enterprise is largely departmental—"spokes in a wheel." This series of articles has for its object the featuring in a racy, interesting and instructive fashion, the training, experience and achievement of those who to-day are transmitting, effectively, energy in their capacity as "spokes in the wheels" of our metal-working establishments.

JOHN WILKIE TAYLOR

THE increasing importance of the shipping industry, which is now being brought before the general public by events not of the pleasantest, is of more than passing interest to our readers, not only on account of the manufacturing activity which is expected to result from present developments, but also because of the more intimate knowledge ensuing with regard to ships' equipment and personnel. The part played by the machine shop in the annual round of marine life in this country is too important to be overlooked. Not only so, but the influence of early experience during the formative period of an engineer's life has more than a little to do with the ultimate niche which he may occupy in industry's gallery.

As chief engineer of the Western Canada Flour Mills Co., Goderich, Ont., John Wilkie Taylor occupies a post of considerable importance not only from a technical viewpoint, but also, at the present moment, from a standpoint of international exigency; a daily capacity of 10,000 barrels of flour by the various plants will perhaps facilitate perception of the reference. Despite the fact that he has a "shore job," Mr. Taylor's success has been largely influenced by a happy combination of constructive and operative experience. Born of Scottish parents at Nottawa, Ont., 1868, Mr. Taylor is Canadian to the core, his life activities having afforded opportunity for becoming intimately acquainted with many widely separated parts of his native land.

His early education was obtained in the public schools of Nottawasaga Township, passing the entrance examinations at 13 years of age. In May, 1880, an apprenticeship was commenced in the establishment of Nathan Veitch, iron-founder and machinist, at Nottawa, and although, as our "Spoke" remarks, the plant was somewhat primitive, the proprietor, by reason of his personal interest in the youthful employee, more than made up for the shortcomings of his equipment. Mr. Veitch was a real

"old guard" of the trade, having come from the Howden shops in Glasgow, Scotland, and the thorough manner in which he grounded our friend in the rudiments of the foundry and mechanical trades has been the cause of life-long gratitude on the part of Mr. Taylor.

On the conclusion of his apprenticeship Mr. Taylor spent a year at Collingwood as assistant engineer in a large saw mill owned by the A. M. Dodge Co., of New York. His contact with shipping at this port created a desire for marine experience, and during the three seasons ending 1890 he was in charge of small craft plying from that port. A position as staff engineer with the Great Northern Transit Co. of Collingwood was fol-



JOHN WILKIE TAYLOR

lowed in 1894 by appointment to the post of chief engineer in charge of the fleet of the Dominion Fish Co., Georgian Bay. This position he relinquished for a year

to join the Holland and Emery Lumber Co., at Byng Inlet, returning to the former company and superintending the overhauling of their fleet while wintering at Goderich. The year 1900 was rendered memorable in our "Spoke's" life by the burning of the passenger steamer Persia, of which he was chief engineer. The event was not without its recompense, as he had full charge of the rebuilding of the engines, boilers and mechanical equipment, a task which was of considerable value in view of the experience obtained, as was evidenced by the performance of similar work for the Dominion Fish Co., in connection with their passenger steamer Manitou.

Recent events have acted as a forcible reminder of the three years from 1904 to 1907, which were spent as chief engineer on the steel freighter Algonquin, this craft having recently fallen a victim to the torpedo of a Hun submarine off the coast of England. Mr. Taylor at this time was a strong advocate for the adoption of quadruple expansion engines, and while a bulk lake freighter of 10,000 tons was so fitted at that time and demonstrated the efficiency of the type of engine, further adoption was negated by the extra amount of space required. His admiration for this highly developed type of engine was given full scope, when after four years with the Montreal Transportation Co., he became chief engineer of the turret steamer Scottish Hero, of the Canadian Lake & Ocean Navigation Co. This vessel had quadruple expansion engines and had been refitted with Scotch boilers for 215 lbs. pressure, the two years' operation of which provided additional experience of a valuable nature, calculated to render our friend particularly fitted for the control and direction of the extensive equipment for which he is now responsible, and to which he was appointed in 1913, resigning from an important appointment with the Merchants' Mutual Line to accept the position.

The practical experience outlined has been combined with frequent opportunities to study power plant conditions in the States as well as Canada, and Mr. Taylor speaks highly of the degree to which Western Canada industrial equipment has been developed. A feature of Mr. Taylor's success has been the extent to which he relied on self-tuition for acquiring his theoretical knowledge. During early days in lake service, the winter months were spent in machine shops, and evenings devoted to study, the benefits being evidenced by the steady progress in his profession. His advice, therefore, to the young mechanical engineer has the feature of personal success behind it. "I most strongly advise serving an apprenticeship in some good engineering shop along with a technical school training, and throughout life a diligent study of trade and engineering journals.

As is frequently the case with men much occupied in industrial pursuits, Mr. Taylor has not spent much of his time in political matters, being strictly independent in his views. He has, however, been a life-long member of several fra-

ternal societies and a number of Masonic orders, and when he retired from lake engineering was made an honorary member of Midland Council, National Association Marine Engineers.

Mr. Taylor's private life is now spent at Goderich, where he resides with his wife and family on Lighthouse Street, his ability having descended to one son, who is serving in an engineering capacity with the Standard Oil Co. at Taft, California.



TORONTO BRANCH C.M.A. ANNUAL MEETING

EIGHT hundred firms and corporations are now enrolled in the Toronto branch membership of the Canadian Manufacturers' Association, according to the report of the Secretary, H. Macdonald, at the seventeenth annual meeting, held a few days ago. The figures show an increase of eighty-seven on the year. The meeting was held at the Central Technical School and prominent among the matters getting the association support were technical education and the imperative need for its extension.

A wide range was covered by the address of the Chairman, Thomas Roden. Major L. L. Anthes was, by acclamation, elected chairman for 1917-18, and J. Western vice-chairman. Outside of association business, there were brief addresses by Dr. A. C. MacKay, Principal of the Technical School, and Miles Vokes, Chairman of the Board of Education. Several speakers touched on the criticism which had been directed against the Central Technical School by Mayor Church. Resolutions were passed in appreciation of technical instruction; approving the establishing of Government Bureau for industrial research, and for further housing methods on modern lines in Toronto. Nearly all aspects of civic, industrial and public policies were included in the scope of the lengthy reports.

Anticipating the Future

In the Chairman's remarks it was stated that "with Canada approaching one of the most critical periods in her existence, caused by the necessity of readjusting her production from a war to a peace basis, it is imperative upon us as business men to bring our united counsels to bear in an effort to anticipate the problems. The sphere of influence and activities of the association have become so extensive, embracing such great diversifications of interest, yet providing a common ground upon which divergent views may be harmonized, that its deliverances must necessarily take upon themselves as atmosphere of broad and comprehensive statesmanship. This same general view has actuated strongly the deliberations of the committee of Toronto branch, and during the year I have had abundant evidence of the respect and esteem in which our association is held."

Trade of Canada

The last fiscal year showed the trade of Canada to have been nearly twice

that of 1914-15. The ordinary revenue of the Dominion amounted to about \$230,000,000, or \$100,000,000 more than that of 1914-15. The revenue of the past year—the largest in our history—will be sufficient to meet all the ordinary and capital expenditures of the country, and in addition pay fifty or sixty million dollars of the expenditures for war purposes. The total trade of the Dominion will be found to have reached about two billion dollars or a billion dollars more than that of the fiscal year in which the war began. Mr. Roden then touched on the duty of manufacturers to co-operate with the Government to meet after-war conditions.

Tariffs

"At an Allies Conference in Paris," he went on, "certain resolutions were adopted looking to the formation after the war of a species of commercial union of the anti-German powers. It is, of course, too soon to presage the nature of the effect, but it is not too soon for all who are engaged in commercial and industrial pursuits to become continuously watchful observers. More care should be exercised in the selection of people before appeals for immigration are made for the sake of labor and good citizenship, and the granting of the franchise should be more carefully considered. Owing to the ignorance of our language on the part of many of our immigrants and the lack of knowledge of our traditions and ideals, many abuses are likely to develop unless restrictive measures are imposed."

Industrial Research Needed

"If there is one thing that is particularly lacking in Canada, it is industrial research. Sir George Foster's appointment of the Advisory Board, of which Professor Macallum is the head, cannot be too highly appreciated. This terrible war with our loss of man-power and increase of taxes necessitates the most careful conservation and utilization of both our natural and industrial resources. To do this, as manufacturers we must be keenly alive to the crisis we shall pass through after the war and lose no time in making definite plans to co-operate in every way to utilize to the fullest the facilities which may be afforded by the Advisory Board."

In the Secretary's report it was stated that by a vigorous campaign to secure a series of scholarships to be awarded by the manufacturers in connection with the day courses at the Central Technical School for the past session, thirty-one scholarships of \$25 each were secured. Five more were given at the meeting.

The Executive pledged the support of the Branch in any feasible plan for securing suitable employment of returned soldiers. The number of men who have found employment to date is 3,240. So far as the Commission know there is no discharged soldier able and willing to work who is at the present time out of employment in the Province. The prospects for employment of discharged soldiers in the future seem very bright.

Discrimination Against Home Capacity

The Executive reported having given serious consideration to the subject of the growing and persistent discrimination by Government departments against the employment of Canadian architects, engineers, contractors and manufacturers, in the construction of public works. The policy complained of is viewed as inconsistent with the efforts which are being made through our universities and other educational institutions to develop into a high state of efficiency the young men of the country. It is felt that the conservation and development of the manhood resources of the country, no less but rather more, than our material resources, are the concern of the whole country.

"Viewed generally, the year just ended has given every evidence of the vast resources of this country, and its ability quickly to adapt and adjust itself to new and changed conditions. Fair harvests, with prices unparalleled for agricultural produce, unequalled activities in our factories, labor enjoying the highest wages of recent times, further substantial increase in the country's favorable trade balance and heavy increase in bank deposits are some of the factors which go to mark 1916 as an abundantly prosperous year in Canada."

New Officers

The following were the representative elections for the ensuing year:

Canadian National Exhibition Association: Messrs. G. T. Irving, J. P. Murray, George Brigden, J. S. McKinnon, W. C. Phillips, Sam Harris, E. J. Freyseng, James Litster, T. A. Russell, John Firstbrook, W. C. Coulter and H. N. Cowan.

Representatives to Executive Council: Messrs. George Brigden, J. P. Murray, W. C. Phillips, G. Frank Beer, R. D. Fairbairn, Thomas Findlev, W. B. Tindall, T. F. Monypenny, W. C. Coulter, J. Western, J. S. McKinnon, Sam Harris, Thomas Roden, E. J. Freyseng and R. L. McIntyre.

Branch Executive: Messrs. R. L. McIntyre, W. C. Laidlaw, James Litster, A. H. Jeffrey, F. E. Mutton, S. H. Chapman, T. F. Monypenny, J. P. Murray, John Hillock, G. B. Clark, John Miller, N. Neilson, J. A. Riordon and F. W. Stone.

The resolution on technical education was moved by J. S. McKinnon, seconded by J. F. Ellis; that on industrial research by W. B. Tindall, seconded by T. F. Monypenny; that on suburban settlement and housing by S. R. Parsons, and seconded by G. Frank Beer.



Release Steel for Rails.—Steps are being taken to provide for the rolling of rails required for renewals in Canadian Government railways in Canada. An arrangement will be made with the Imperial Munitions Board, which has first call upon the steel output, for the release of metal for the purpose. The mills at Algoma Steel Co. and Dominion Steel Corporation will be utilized for this work.

PROGRESS IN NEW EQUIPMENT

A Record of New and Improved Machinery and Accessories for the Machine, Pattern, Boiler and Blacksmith Shops, Planing Mill, Foundry and Power Plant

24-IN. HELICAL-GEARED SHAPER

EXPERIMENTS with helical tooth driving gears in shapers have been in progress for several months by the Queen City Machine Co., Cincinnati, Ohio, and as a result it has been decided to make

etc., have been available to small power users such as farms, country churches, camps, railroad stations, and isolated inns and boarding houses, but the designs of the set illustrated herewith have made departure from the present tendency by discarding belts, storage bat-

teries and starting devices, and have developed a unit which is claimed to be capable of running continuously night and day if required, the cost of the comparatively idle extra running being less than that of storage battery depreciation.

The engine end of the Uni-Lectric lighting and power plant is shown in the engraving, the rated capacity of the set being 500 watts ($\frac{1}{2}$ k.w.) at 110 volts, direct current. A generous overload capacity renders it capable of running fifty 15-watt lamps, or any combined light and power load up to 750 watts, so that two motors of $\frac{1}{2}$ horse-power each may be run from it.

The well-known efficiency of the sleeve-valve type of engine over long periods of continuous operation induced the designers to adopt this principle. The 4 stroke-cycle is employed with a single cylinder of $2\frac{1}{4}$ in. bore and 3 in. stroke. The sleeve, however, is of the revolving type which thus leaves the piston and piston rod as the only reciprocating parts in the entire construction. The cylinder casting is provided with exhaust and intake ports, and the sleeve which is carefully ground to a proper fit is arranged with two diametrically opposite ports for registration with the cylinder ports. The piston is located inside the sleeve and reciprocates in it as though it were the true cylinder. The sleeve is driven at only one revolution to four re-

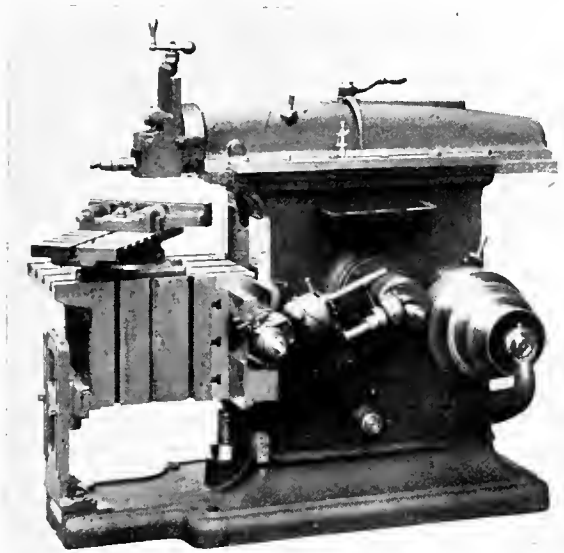

24-IN. HELICAL-GEARED SHAPER.

this type of drive standard on their 24-in. machine. This type of gearing operates without noise or backlash, and although a comparatively small helix angle is adopted, 14 deg. 55 min., at least three teeth are in mesh together, resulting in a smooth movement of the ram without any shock.

The fine finish obtainable on work was largely responsible for the adoption of this drive, the results being only equalled by machine with spiral gear drive; the strength and wearing qualities being greatly increased, while the greatly reduced vibration adds considerably to the life of the machine as a whole.

In addition to this new feature the machine possesses other interesting features, such as heat-treated journals with ring-oiling bearings; the use of semi-steel castings made by the McLain process; quick change feed mechanism, which is fully enclosed and is manipulated without the operator having to handle any moving parts.



$\frac{1}{2}$ K.W. DOMESTIC LIGHTING AND POWER PLANT

THE problem of designing a home-size lighting plant is one which has engaged the attention of electrical engineers for some time, with varying degrees of success. Belt-driven and direct-connected sets with self-starting arrangements,

teries and starting devices, and have developed a unit which is claimed to be capable of running continuously night and day if required, the cost of the comparatively idle extra running being less than that of storage battery depreciation.

The engine end of the Uni-Lectric lighting and power plant is shown in the engraving, the rated capacity of the set being 500 watts ($\frac{1}{2}$ k.w.) at 110 volts, direct current. A generous overload capacity renders it capable of running fifty 15-watt lamps, or any combined light and power load up to 750 watts, so that two motors of $\frac{1}{2}$ horse-power each may be run from it.

The well-known efficiency of the sleeve-valve type of engine over long periods of continuous operation induced the designers to adopt this principle. The 4 stroke-cycle is employed with a single cylinder of $2\frac{1}{4}$ in. bore and 3 in. stroke. The sleeve, however, is of the revolving type which thus leaves the piston and piston rod as the only reciprocating parts in the entire construction. The cylinder casting is provided with exhaust and intake ports, and the sleeve which is carefully ground to a proper fit is arranged with two diametrically opposite ports for registration with the cylinder ports. The piston is located inside the sleeve and reciprocates in it as though it were the true cylinder. The sleeve is driven at only one revolution to four re-



THE ELECTRIC FURNACE

THE use of the electric iron and steel furnace has made exceptional progress under war conditions. When the demand for steel exceeds the supply, and junk

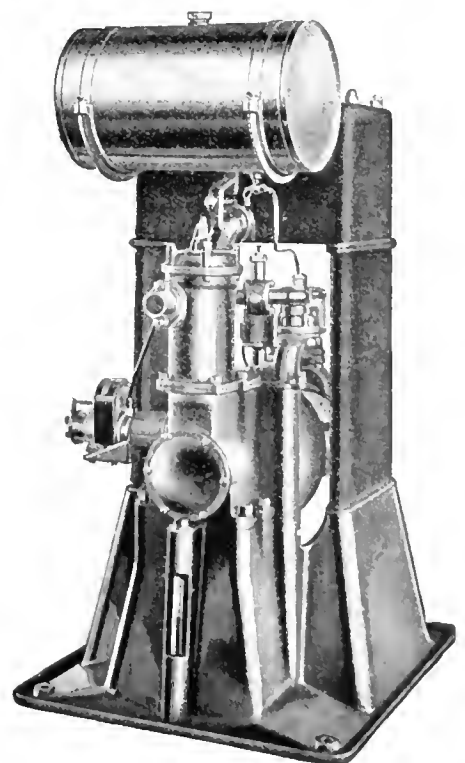

HALF-KILOWATT DIRECT-CONNECTED GASOLINE-DRIVEN LIGHTING AND POWER SET.

piles are searched for available metal, the electric steel furnace experiences a boom because it is capable of making an excellent quality of steel from a comparatively poor quality of iron and steel scrap. As more and more careful conservation of natural resources becomes necessary, electrical processes steadily gain ground because of their greater economy in the use of raw materials.

At the beginning of 1916 there were 73 electric steel furnaces in the United States producing 100,000 tons per year; to-day there are over double this number with a yearly production exceeding 1,000,000 tons. These furnaces require in the neighborhood of 150,000 h.p., one of the largest single installations having a total capacity of 70 tons in units of 15 and 20 tons.

The relative growth in Canada is even greater; electric furnace steel production has increased from 61 tons in 1915 to 43,790 tons in 1916. In Montreal alone, according to figures supplied by the Civic Investment and Industrial Co., there are in operation, or being installed, 11 electric furnaces requiring a total of 17,000 h.p. The larger furnaces, when fed from high tension lines and properly controlled, offer no serious disturbances to their circuits, but a plant of less than 5,000 h.p. capacity should not attempt to carry single phase furnaces of 400 k.w. or over. The possibilities as an off-peak load are good as the usual length of heat is only about three hours, which condition would adapt itself excellently to a limited service operation. The furnaces can be operated economically at from 1c. to 1½c. per k.w.h., and such rates are now in force in many Canadian centres for ordinary service such as house lighting.



SHIPBUILDING DIFFICULTIES

THE scarcity of steel is given as one reason why any important progress in the development of steel shipbuilding in Canada may have to be deferred. Steel capacity within Canada is largely taken up until the middle of 1918, with the bulk of contracts based on Government requirements in connection with munitions. These contracts may be further enlarged to absorb most of the output for 1919, so, unless any considerable part of the capacity of the mills should be released from munitions on the ground that shipbuilding might be more urgent, the outlook is not encouraging. Even in that event there would be delays until mills to roll ship plates could be equipped.

On the financial side, others see difficulties for an extensive shipbuilding programme in the new Canadian taxation. One large eastern concern is said to have laid aside its plans for a shipbuilding plant on the ground that new capital could not be enlisted in support of such an enterprise, when the risks of loss would have to be heavily scaled down to meet taxes. This, too, is said to be entering as an adverse factor in the plans of some American capital that was coming into the country for the purpose.

DEATH SUMMONS A. R. WILLIAMS
ADVICE of the death of Alfred Ruggles Williams, which occurred on the afternoon of Friday, May 18, at his residence, 56 Madison Avenue, Toronto, after an illness of four days, following a stroke of paralysis, will be received with regret by his many friends and business acquaintances.

The late Mr. Williams, who was widely known as the president of the A. R. Williams Machinery Co., Toronto, with branches at Winnipeg, Man., Vancouver, B.C., and St. John, N.B., was born in Troy, Bradford County, Pa., on December 26, 1838, son of John Wood Williams, of Devonshire, England, and Louise Lee (Ruggles) Williams, of Vermont. Following his education in the public schools of Troy, Pa., and later at a private seminary in Lima, N.Y., he joined his father, who was a farmer and maltster. For con-

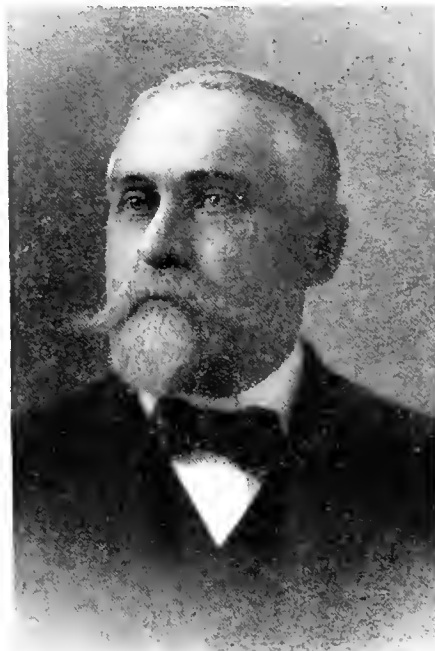

THE LATE ALFRED RUGGLES WILLIAMS.

scientious reasons, however, he soon abandoned the career of maltster.

His first experience of the machinery business, 1862-1868, was gained with the firm of Paterson Bros., Richmond Hill, Ont., in the capacity of traveller; later he assumed management and control of the business. With Robert Thompson he settled at Mitchell, Ont., establishing the foundry business of Thompson & Williams, manufacturers of reapers, mowers, agricultural implements generally, grist and saw mills, steam tractors, etc. In 1875 the plant was removed to Stratford, Ont., a limited liability company being formed under the firm name of The Thompson-Williams Mfg. Co. The nucleus of the present business was organized in Toronto in 1882, being afterwards incorporated in 1894 as the A. R. Williams Machinery Co. The different branches were established as follows: Montreal, 1887; Winnipeg, 1903; Vancouver, 1905; St. John, 1910. Deceased was also a director of Williams & Wilson, machinery dealers, Montreal, and director and vice-

president, the Toronto Structural Steel Co.

Mr. Williams' first wife, Mary S. Gould, only daughter of Isaac H. Gould, of Wyoming, N.Y., died in 1903, and is survived by Mary Bartha, wife of Walter H. Clemes, director of the A. R. Williams Co. In 1907 he married Carrie Elinor Baker, of Stratford, Ont., and the two children of the marriage, Alfred Ruggles, jr., and Elinor May, survive.

While resident in Mitchell, Ont., the late Mr. Williams was president of the Public School Board and was active in establishing the High School. Always a stalwart advocate of all benevolent measures and a co-operator in church and temperance work, he took especial interest in the advancement of the Sunday school movement, acting as superintendent of the Central Methodist Sunday School, Toronto, for eighteen years. He was an ex-member of the Sons of Temperance and the Independent Order of Good Templars, and was vice-president of the Committee of One Hundred.

In business life the late Mr. Williams was a member of the Toronto Board of Trade, the Canadian Manufacturers' Association, and the London Association of Commercial Travelers.

The public funeral took place on Monday afternoon, May 21, to Mount Pleasant Cemetery, Toronto. In addition to a private service at deceased's late residence, a public service was held in Central Methodist Church, among those present being the employees of the various A. R. Williams Machinery Co. plants and representatives of a wide variety of social, business and society interests.



MINERAL PRODUCTION FOR THREE MONTHS

THE quarterly report of the Ontario Bureau of Mines covering the records of Ontario's mineral production for the first three months of this year, shows that copper and nickel are running at smelter capacity; gold is being mined in increasing quantity, but silver has dropped in production below the totals for the same period in 1916. Iron ore shows a remarkable increase and considerable increases are also reported in all other items of metalliferous production within the province.

The output of gold was 127,692 ounces, valued at \$2,601,760, the Hollinger, Dome and McIntyre camps being the largest producers; 3,945,957 ounces of silver were produced, as against 5,207,831 ounces for the same period in 1916. The value of the silver output was \$2,831,873; 10,141 tons of nickel matte and 5,063 tons of copper matte were produced; 52,694 tons of iron ore were mined, as compared with 6,573 tons turned out for the first quarter of last year.



"Willie," said his mother, "I wish you would run across the street and see how old Mrs. Brown is this morning." A few minutes later Willie returned and reported: "Mrs. Brown says it's none of your business how old she is."

The MacLean Publishing Company
LIMITED

(ESTABLISHED 1888)

JOHN BAYNE MACLEAN - - - - - President
H. T. HUNTER - - - - - Vice-President
H. V. TYRRELL - - - - - General Manager

PUBLISHERS OF

CANADIAN MACHINERY
AND MANUFACTURING NEWS

A weekly newspaper devoted to the machinery and manufacturing interests.

PETER BAIN, M.E., Editor. B. G. NEWTON, Manager.
Associate Editors
A. G. WEBSTER J. M. WILSON J. H. RODGERS

Office of Publication, 143-153 University Avenue, Toronto, Ont.

Vol. XVII. MAY 24, 1917 No. 21

MEN WHOM WE CAN ILL SPARE

FULL of years as the measure of life is reckoned, and bearing alike the respect of those who knew him in a business way and of those to whom contact as a private citizen was vouchsafed, Alfred Ruggles Williams, has passed to the Great Beyond. A record such as his is by no means common, combining as it does business success in a superlative degree, the lack of public honors usually thrust upon men under such circumstances but withal embodying and displaying those attributes of character and adherence to principle and virtue which put the guinea stamp on a man and endear him to his fellows. His business interests, although large and prosperous, and for the most part, therefore, with a tendency to engross his individual attention, never appear during his long life course to have eclipsed or side-tracked the many opportunities always offering for social service, rather will it be found that his interests in the latter direction were equally large and important, and the measurement of achievement equally valuable as those relating particularly to the buying and selling of machinery. The reputation of the A. R. Williams Machinery Co. is front rank, wherever it has transacted business, and it goes without saying that such a circumstance is entirely due to the integrity and sterling worth of its now deceased founder.

Men of Alfred Ruggles Williams' calibre are all too rare in every walk of life, and the loss of one, even although the allotted span has been materially extended in his case, leaves an undesirable gap in the ranks. At any time the work and effort of such men are valuable and fruitful to either a community or a nation, but in times like these, doubly so; as a consequence the passing of but one appeals to us as though he could be ill spared.

MODIFICATION OF WAR TAXATION IN ORDER

JUDGING by the urgent need of ships to replace those sunk and being sunk by enemy submarines and mines, there is great opportunity for the establishment of additional shipbuilding plants in Canada, more especially on her ocean and ocean waterway shores. In previous issues we have urged that advantage be taken of the opportunity offering. Quite a number of shipyards have

been projected and a good deal of preliminary work done with reference to them, but there is an apparent tendency for all of them to more or less "hang fire." Lack of Government support, lack of equipment and structural material readily available, and the recent War Tax announcement, are individually and collectively responsible for the hesitancy to take definite action, and on the latter of the three deterrents—the War Tax business profits, there is good reason to believe that considerable onus lies.

The two most important things that must be encouraged in Canada to-day are increased production and increased thrift and saving. The enormous tax which is proposed upon the profits of some incorporated companies, acts as the greatest discouragement to initiative and to production that could well be devised. Business men to-day are prepared to assume heavy burdens and to pay large taxes. Men, however, who are responsible for the investment of money for this cannot assume a responsibility which places upon them the possibility of large losses on the one hand, if unsuccessful, and on the other hand, of only a fraction of the profits gained if the operations are successful. We want to encourage production on the farm to-day. We want to encourage production in the factory. We want to encourage the re-investment in improved plant by manufacturers. We want to encourage the introduction of fresh capital into Canada and the conservation in Canada of her resources.

In this tax on profits the Minister of Finance has gone too far in one direction. He must modify it before it is too late, and if he finds it necessary to replace some revenue which he thinks is going to be lost thereby, then put some tax upon those articles, the consumption of which should be restricted in Canada to-day. Put some tax on the great incomes—ranging from \$100,000 to \$1,000,000 a year—which are drawn by people who have their investments in bonds and mortgages—much of whose money was made in real estate and other speculation—and who are themselves taking no risk and contributing nothing by their enterprise or ability to production in the country.

Until some material modification of the War Taxation as it applies to business enterprise, established or projected, is made effective, we may look to see not only initiative chilled as regards shipbuilding, but relative to all forms of industry, manufacture, and resources development.

INDUSTRY AND CONSCRIPTION

THE announcement by Sir Robert Borden soon after his return from England that conscription would be resorted to at an early date to maintain the forces of the Dominion at the required strength was not unexpected by observers of events. Chief among such are the manufacturers, especially those in the metal-working industries, and their reception of the announcement has not been such as to occasion grave fears of industrial dislocation and its attendant results.

This last effort is far more likely to affect those strata of society which are unconnected with machine shop interests. The call for labor to carry out the shipbuilding program alone will place a considerable number of manual workers outside the scope. The availability of numbers of women operators due to recent decrease of shell production will in some measure make good the possible drafting of machinists from non-essential trades.

The event should be accepted by the country as final evidence of the seriousness of the war, and if accompanied by reduction of extravagance, and increased production of necessities, with proper control of same, the future results of the present step can be but for the best, industrially, financially and politically.

SELECTED MARKET QUOTATIONS

Being a record of prices current on raw and finished material entering into the manufacture of mechanical and general engineering products.

PIG IRON.	
Grey forge, Pittsburgh.....	\$40 95
Lake Superior, charcoal, Chicago	46 75
Standard low phos., Philadelphia	75 00
Bessemer, Pittsburgh	44 95
Basic, Valley furnace	42 00
Montreal Toronto	
Middlesboro, No. 3
Cleveland, No. 3
Clarence, No. 3
Hamilton
Victoria	50 00

FINISHED IRON AND STEEL.	
Per lb. to Large Buyers	Cents
Iron bars, base, Toronto	4 75
Steel bars, base, Toronto	5 00
Steel bars, 2 in. to 4 in. base	6 00
Steel bars, 4 in. and larger base	7 00
Iron bars, base, Montreal	4 75
Steel bars, base, Montreal	5 00
Reinforcing bars, base	5 10
Bessemer rails, heavy, at mill	38 00
Steel bars, Pittsburgh	4 00
Tank plates, Pittsburgh	6 50
Beams and angles, Pittsburgh	4 00
Steel hoops, Pittsburgh	4 25
F.O.B., Toronto Warehouse.	
Steel bars, base	5 00
Small shapes	5 25
F.O.B. Chicago Warehouse	
Steel bars	4 25
Bars, 2 in. and up	4 40
Structural shapes	4 75
Plates	6 00

FREIGHT RATES.	
Pittsburgh to Following Points	Per 100 lbs.
C.L.	L.C.L.
Montreal	23.1 31.5
St. John, N.B.	35.1 45.5
Halifax	35.1 45.5
Toronto	18.9 22.1
Guelph	18.9 22.1
London	18.9 22.1
Windsor	18.9 22.1
Winnipeg	64.9 85.1

METALS.	
Montreal Toronto	
Lake copper	\$38 50 \$37 00
Electro copper	38 50 37 00
Castings, copper	37 50 36 00
Fin	62 50 68 00
Spelter	13 50 12 00
Lead	13 50 13 25
Antimony	27 00 30 00
Aluminum	70 00 68 00

PLATES.	
Montreal Toronto	
Plates, 1/4 to 1/2	\$9 00 \$8 00
Heads	9 30 8 10
Tank plates, 3-16 in.	9 10 8 10

WROUGHT PIPE.	
Effective May 14, 1917.	
Black Galvanized	
Standard Butt weld.	
Size.	Per 100 feet
1 in.	11 73 14 88
1 1/4 in.	15 87 20 13
1 1/2 in.	18 98 24 06
2 in.	25 53 32 38
2 1/2 in.	40 95 51 77
3 in.	53 55 67 70
3 1/2 in.	66 24 83 26
4 in.	78 48 98 65
4 1/2 in.	\$ 4 50 \$ 6 00
5 in.	4 96 7 00
6 in.	4 96 7 00
8 in.	6 29 7 86
10 in.	7 94 10 06
Standard Lap weld.	
2 in.	28 49 34 97

2 1/2 in.	42 71	52 94
3 in.	55 85	69 23
3 1/2 in.	68 08	86 02
4 in.	80 66	101 90
4 1/2 in.	93 98	118 70
5 in.	109 50	138 40
6 in.	142 10	179 50
7 in.	185 60	232 05
8 L in.	195 00	243 75
8 in.	224 60	280 80
9 in.	269 10	336 38
10 L in.	249 60	312 00
10 in.	321 40	401 70

Prices—Ontario, Quebec and Maritime Provinces.

WROUGHT NIPPLES.	
4" and under, 50%.	
4 1/2" and larger, 45%.	
4" and under, running thread, 30%.	
Standard couplings, 4" and under, 40%.	
4 1/2" and larger, 20%.	

OLD MATERIAL.	
Dealers' Buying Prices.	
Montreal Toronto	
Copper, light	\$22 00 \$20 00
Copper, crucible	26 00 25 00
Copper, heavy	26 00 24 50
Copper wire	26 00 24 50
No. 1 machine com-position	21 50 20 00
New brass clippings	18 00 17 00
No. 1 brass turnings	16 00 16 00
Heavy melting steel	19 00 17 00
Steel turnings	8 00 8 00
Shell turnings	12 00 12 00
Boiler plate	19 00 10 50
Axles, wrought iron	22 00 24 00
Rails	19 00 18 00
No. 1 machine cast irons	22 00 22 00
Malleable scrap	17 00 16 00
Pipe, wrought	14 00 9 00
Scrap zinc	8 00 9 50
Tea lead	7 50 7 00
Aluminum	32 00 35 00

BOLTS, NUTS AND SCREWS.	
	Per Cent.
Coach and lag screws	25
Stove bolts	55
Plate washers	10
Machine bolts, 7-16 and over	net
Machine bolts, 3/8 and less	10
Blank bolts	net
Bolt ends	net
Machine screws, fl. and rd. hd., steel	27 1/2
Machine screws, o. and fil. hd., steel	10
Machine screws, fl. and rd. hd., brass	add 20
Machine screws, o. and fil. hd., brass	add 25
Nuts, square blank	add \$1 50
Nuts, square, tapped	add 1 75
Nuts, hex. blank	add 1 75
Nuts, hex. tapped	add 2 00
Copper rivets and burrs, list plus	30
Burrs only list plus	50
Iron rivets and burrs	17 1/2
Boiler rivets, base 3/4 in. and larger	\$6.65
Structural rivets, as above	6.55
Wood screws, flat, bright	.72 1/2
Wood screws, O. & R., bright	.67 1/2
Wood screws, flat, brass	.37 1/2
Wood screws, O. & R., brass	.32 1/2
Wood screws, flat, bronze	.27 1/2
Wood screws, O. & R., bronze	.25

MILLED PRODUCTS.	
	Per cent.
Set screws	35
Sq. & Hex. Head Cap Screws	30
Rd. & Fil Head Cap Screws	10
Flat 3/8 But. Hd. Cap Screws plus	10
Fin. & Semi-fin. nuts up to 1 in.	25
Fin. and semi-fin. nuts, over 1 in., up to 1 1/2 in.	30
Fin. and semi-fin. nuts, over 1 1/2 in., up to 2 in.	10
Studs	20
Taper pins	40
Coupling bolts, plus	10
Planer head bolts, without fillet (list plus 10 and 10).	
Planer head bolts, with fillet (list plus 10 and 10).	
Planer head bolt nuts, same as finished nuts.	
Planer bolt washers	net
Hollow set screws	list plus 20
Collar screws	list plus 30, 10
Thumb screws	20
Thumb nuts	65
Patc bolts	add 40, 10
Cold pressed nuts to 1 1/2 in.	add \$4.50
Cold pressed nuts over 1 1/2 in.	add \$7.00

BILLETS.	
	Per gross ton
Bessemer billets	\$ 80 00
Open-hearth oilets	80 00
O.H. sheet bars	80 00
Forging billets	105 00
Wire rods	85 00
F.o.b. Pittsburgh.	

NAILS AND SPIKES.	
Wire nails	5 00 4 95
Cut nails	5 00 5 00
Miscellaneous wire nails	60%
Pressed spikes, % diam., 100 lbs.	5 30

MISCELLANEOUS.	
Solder, strictly	0 36
Solder, guaranteed	0 39
Babbitt metals	14 to 60
Soldering coppers, lb.	0 53
Putty, 100-lb. drum	4 35
White lead, pure, cwt.	16 03
Red dry lead, 100-lb. kegs, per cwt.	13 87
Glue, English	0 38
Tarred slaters' paper, roll	0 95
Gasoline, per gal., bulk	0 31 1/2
Benzine, per gal., bulk	0 30 1/2
Pure turpentine, single bbls., gal.	0 72
Linseed oil, raw, single bbls.	1 40
Linseed oil, boiled, single bbls.	1 43
Plaster of Paris, per bbl.	2 50
Plumbers' oakum, per cwt.	9 00
Packing, square braided	0 32
Packing, No. 1 Italian	0 38
Packing, No. 2 Italian	0 30
Lead wool, per lb.	0 15
Pure Manila rope	0 33 1/2
Transmission rope, Manila	0 43 1/2
Drilling cables, Manila	0 38 1/2

POLISHED DRILL ROD.
Discount off list, Montreal and Toronto 25%

CARBON DRILLS AND REAMERS.	
	Per Cent.
S.S. drills, wire sizes up to 52 40	
S.S. drills, wire sizes, No. 53 to 80	25
Standard drills to 1 1/2 in.	40
Standard drills, over 1 1/2 in.	15
3-fluted drills, plus	10
Jobbers' and letter sizes	40
Bit stock	40
Ratchet drills	15
S.S. drills for wood	40
Wood boring brace drills	25
Electricians' bits	30
Sockets	40

Sleeves	40
Taper pin reamers	20
Drills and countersinks	list plus 30
Bridge reamers	45
Centre reamers	10
Chucking reamers	10
Hand reamers	15

COLD ROLLED SHAFITING.
At mill list plus 40%
At warehouse list plus 50%
Discounts off new list. Warehouse price at Montreal and Toronto.

IRON PIPE FITTINGS.	
Canadian malleable, A, add 10%; B and C, 10%; cast iron, 35%; standard bushings, 50%; beaders, 60; flanged unions, 40; malleable bushings, 50; nipples, 55; malleable lipped unions, 50.	

SHEETS.	
Montreal Toronto	
Sheets, Black, No. 28	\$7 75 \$8 10
Sheets, Black, No. 10	7 50 7 90
Canada plates, dull, 52 sheets	7 00 7 00
Canada plates, all bright	8 00 8 00
Apollo brand, 10% oz. galvanized	7 25 7 25
Queen's Head, 28 B. W.G.	7 75 7 75
Fleur-de-Lis, 28 B.W. G.	7 45 7 35
Gorbal's Best, No. 28	8 25 7 50
Colborne Crown, No. 28	8 00 6 75
Premier, No. 28 U.S.	8 30 8 70
Premier, 10% oz.	8 60 9 00

PROOF COIL CHAIN.	
B	
1/4 in.	\$9 75
5-16 in.	9 40
3/8 in.	8 65
7-16 in.	7 45
Soldering coppers, lb.	7 25
9-16 in.	7 25
5/8 in.	7 15
3/4 in.	7 05
3/8 in.	7 00
1 inch	6 90
Extra for B.B. Chain	1 20
Extra for B.B. Chain	1 80

ELECTRIC WELD COIL CHAIN B.B.	
1/2 in.	\$15 50
3-16 in.	11 70
1/4 in.	8 40
5-16 in.	7 40
3/8 in.	6 35
7-16 in.	6 35
1/2 in.	6 35
5/8 in.	6 35
3/4 in.	6 35

Prices per 100 lbs.

FILES AND RASPS.	
	Per Cent.
Great Western, American	55
Kearney & Foot, Arcade	55
J. Barton Smith, Eagle	55
McClelland, Globe	55
Whitman & Barnes	55
Black Diamond	45
Delta Files	40.5
Nicholson	45
Globe	55
Vulcan	55
Disston	35

COAL AND COKE.	
Solvay Foundry Coke	\$10 90
Connelville Foundry Coke	..
Steam Lump Coal	8 50
Best Slack	8 05
Net ton f.o.b. Toronto	

BOILER TUBES.			TAPES.		ANODES.		PLATING CHEMICALS.	
Size.	Seamless	Lap-welded	Chesterman Metallic, 50 ft.	\$2 00	Nickel	.50 to .54	Acid, boracic\$.15
1 in.\$27 00	Lufkin Metallic, 603, 50 ft.	2 00	Cobalt	1.75 to 2.00	Acid, hydrochloric05
1 1/4 in. 33 00	Admiral Steel Tape, 50 ft.	2 75	Copper	.44 to .46	Acid, hydrofluoric14 1/2
1 1/2 in. 35 00	30 00	Admiral Steel Tape, 100 ft.	4 45	Tia	.49 to .56	Acid, nitric10
1 3/4 in. 35 00	30 00	Major Jun. Steel Tape, 50 ft.	3 50	Zinc	.23 to .25	Acid, sulphuric05
2 in. 38 00	30 00	Rival Steel Tape, 50 ft.	2 75	Prices Per Lb.			
2 1/2 in. 46 00	36 00	Rival Steel Tape, 100 ft.	4 45	COPPER SHEETS.			
3 in. 52 00	42 00	Reliable Jun. Steel Tape, 50 ft.	3 50	Montreal Toronto			
3 1/4 in. 48 00			Bars, 1/2 to 2 in.	55 00 53 00	Acid, boric05
3 1/2 in. 62 00	52 00			Plain sheets, 14 oz.	Acid, hydrochloric14 1/2
4 in. 76 00	65 00			14x28 in., 14x60 in.	55 00 53 50	Acid, nitric10
Prices per 100 feet, Montreal and Toronto.			WASTE.		Copper sheet, tinned,	60 00 54 25	Acid, sulphuric05
OILS AND COMPOUNDS.			White		14x60, 14 oz.	60 00 54 25	Ammonia, aqua08
Castor oil, per lb. 27		Cents per lb.		Copper sheet, planished, 14x60 base.	64 00 60 00.	Ammonium carbonate15
Royalite, per gal., bulk. 16		XXX Extra	20	Braziers', in sheets, 6x4 base	55 00 52 00	Ammonium chlorid11
Palatine 19		Peerleas	20	BRASS.			
Machine oil, per gal. 26 1/2		Grand	19	Brass rods, base 1/2 in to 1 in rd.	0 55	Copper, sulphate17
Black oil, per gal. 13		Superior	19	Brass sheets, 8 in. wide, 20 oz.	0 60	Cobalt sulphate70
Cylinder oil, Capital 45 1/2		X L C R	18	Copper tubing, seamless.	0 58	Iron perchloride20
Cylinder oil, Acme 36 1/2		Atlas	18	PLATING SUPPLIES.			
Standard cutting compound, per lb. 6 15		X Empire	18	Polishing wheels, felt.	2 50	Nickel ammonium sulphate12
Lard oil, per gal. 1 45		Ideal	17	Polishing wheels, bull-neck	1 35	Nickel carbonate35
Union thread cutting oil antiseptic 68		X press	16	COLORED.			
Acme cutting oil, antiseptic 37 1/2				Lion	14 1/2	Nickel sulphate15
Imperial quenching oil 39 1/2				Standard	13	Potassium carbonate75
Petroleum fuel oil 11 1/4				No. 1	13	Potassium sulphide (substitute)20
BELTING—NO. 1 OAK TANNED.			WOOL PACKING.		Popular	11 1/2	Silver chloride (per oz.)65
Extra heavy, single and double 30-5%		Arrow	25	Keen	10 1/2	Silver nitrate (per oz.)55
Standard 40%		Axle	20	WASHED WIPERS.			
Cut leather lacing, No.1 1 50		Anvil	15	Select White	12	Sodium bisulphite10
Leather in sides 1 35		Anchor	11	Mixed colored	10	Sodium carbonate crystals65
			This list subject to trade discount for quantity.		Dark colored	69	Sodium cyanide, 127-130%41
			RUBBER BELTING.		LEAD SHEETS.			
			Standard	40%	Montreal Toronto			
			Best grades	20%	Sheets, 3 lbs. sq. ft. \$17 00 \$17 00			

The General Market Condition and Tendency

THE outlook for manufacturers in regard to their iron and steel requirements is not very promising and indications point to a serious shortage at no distant date. Domestic consumers have for some time experienced considerable difficulty in obtaining steel and have had to wait many weeks for delivery. Now, however, the situation is more acute, as the mills both in Canada and the States are filled up with war orders, which, of course, are taking precedence over all other business. Steel prices, although abnormally high, continue to climb, and the end of the upward movement is not in sight. The congestion at the mills, which is increasing, can have no other effect than to send prices up. Wrought pipe and tubes have again advanced, while higher prices are anticipated on steel plates and sheets, and probably on bars. The demand for ship plates is enormous and extraordinary prices are being paid to secure this material owing to the urgency of the situation. Prices of coal are very firm and dealers state that higher prices are practically certain. The pig-iron situation is unchanged, but an advance is looked for in the near future. The scrap market is quiet, but prices are holding firm, particularly on cast iron and steel scrap. The non-ferrous metal markets are firmer, and indications point to higher prices on copper, tin and lead. The supply business continues active with prices holding firm. The more recent advances include hemp packings and Manila rope. The machine tool business has been quieter this week, but a number of interesting enquiries have been received by local machinery houses.

Montreal, Que., May 19, 1917.—The decision of the government to put into force some form of selective conscription has long been awaited with more or less interest, and now that the step has finally been taken, it remains to be seen what period of time will elapse before an actual start is made in the new plan of action. What effect this new development will

eventually have upon the commercial and industrial activity of the country, is at present difficult to determine, but in the accomplishment of the purpose, it is anticipated that slight disorganization will be caused by the system of selection, as it will undoubtedly be necessary to have some sort of a readjustment of the man power of the country in order to meet

the required conditions. The political situation in the States is slowly but surely becoming clearer, but definite information regarding the plans of the government are very vague. The market is still in a somewhat unsettled condition, but the general tendency is a stronger tone with a continued upward movement in price quotations. Production of the heavier types of shells is showing a falling off, but otherwise the activity of this district maintains a brisk and war-time appearance.

Pig Iron

The continued heavy demand for pig iron and the filled-up condition of the producers has again been reflected in higher prices on the American market, but orders are still being placed for first half of 1918 delivery, and with the new developments now in progress the requirements for pig iron will become greater. One dollar per ton has been added to the Pittsburgh quotation of Bessemer, the price being now \$46.95 per ton. Composite pig has advanced over 75 cents during the week, the quotation being \$42.735 per ton. Canadian producers have very little to sell and prices are practically withdrawn.

Steel

The steel situation is still featured by the developing plans of the American government, but full requirements for war purposes have not yet been definitely announced. The market consequently retains a certain degree of uncertainty, and producers are reluctant to take on heavy business for future delivery until they know the tonnage desired for government purposes. The knowledge acquired from the experience of the Allies during

the past three years of war, will no doubt have great bearing in the method adopted in forming a policy for the further prosecution of the war, both as regards purchase and manufacture of every form of munitions and equipment. In addition to supplying the Allies with large quantities of war materials, the placing of an army in the field will require increased energy on the part of manufacturers in keeping up the flow of supplies, and under the circumstances it is more than likely that some domestic enterprise will require to be deferred until a later date. This latter phase of the country's activity has, however, shown considerable decline, owing to the abnormal conditions prevailing in the steel market and the exorbitant prices asked for all grades of steel and iron.

It is generally conceded that the price paid for government requirements will be closer to that prevailing in the open market than was the case in previous purchases. General demands upon producers are unchanged, being such that early delivery is almost impossible. Far future positions are the only ones available, with the exception of small surplus lots offered to old customers. An additional \$10 a ton has been placed on the Pittsburgh quotation of certain grades of unfinished steel; billets are now \$95, sheet bars have attained the century mark, rolling billets are quoted at \$90, while the general price for forging billets is \$110 per ton. Pittsburgh producers have advanced steel bars \$5 per ton, the base price being now 4c. per lb. Following an advance of \$10 per ton, the base on black sheets is now 7½c. On a similar advance, tin mill black is quoted at the same figure. Blue annealed sheets are now 7c. and galvanized 9½c., the week's advance on the latter being \$10 per ton. With the exception of the advance on plates, noted last week, the situation here remains the same, but dealers predict further readjustments in the near future.

Metals

The metal market is becoming more settled as the American political situation develops. Copper is again weakening after the recent upward movement. Tin is fluctuating as conflicting conditions are reported. The higher price of ore has kept spelter firm. Lead is very strong and higher and antimony is quiet, but firm. Aluminum is steady and unchanged.

Copper.—This market is still influenced by pending developments and the recent upward movement has been retarded with a slight decline in prices quoted. The trade is apparently awaiting the further action of U.S. government before entering the market for heavy future requirements. London is firm, but New York shows a weak tendency with a decline of ½c. on the week, the quotation for lake and electro being 32½c. per lb. The local market is firm and unchanged at 38½c. for lake and electrolytic, and 37½c. for castings.

Tin.—This metal is again reacting, and this week's quotation on the New York market, although higher than the corresponding day of last week, is lower than what it was during the interval. A peculiar condition exists in the tin situa-

tion, as many consumers who are oversupplied with metal could resell if not under government restriction. Until action is taken by the authorities, the tin market will continue to be unsettled. London is much higher and New York is still 1¼c. higher than last week, the spot price being 65½c. per lb. Local dealers are quoting 62½c., this being a decline on the week of one cent per lb.

Spelter.—The firmness in this metal is retained more as a result of the higher cost of production than any activity in the general market. New York prices are ¼c. lower than last week, while dealers were continue to quote 13½c. on a quiet market.

Lead.—This metal continues to be the feature of the market as it persistently maintains its abnormal strength in spite of general uncertain conditions. The advance has been gradual but steady, the price having almost doubled in the past five months, opening the year at 5½c. on New York quotations with the present Trust price at 10c. per lb. The market here is very strong, this week's quotation of 13½c. representing an advance of ½c.

Antimony.—The market is easier for future positions, but prompt and early delivery is held firm at last week's quotation of 27c. per lb.

Aluminum is firm and unchanged at 70c per lb.

Machine Tools and Supplies

The decrease in the production of the larger sizes of shells has resulted in a considerable falling off in the machine tool activity, although some light business is still being done in the lighter lines of equipment for the smaller shells. The increasing requirements of shipbuilding is an encouraging feature of the situation, and while established plants in this district are utilizing their old equipment, increased inquiry is reported from other locations. Marine repair shops here are particularly busy and additions are being made to existing equipment. Demands for supplies and accessories are still very heavy, with the costs advancing to meet the higher expenditure necessary in the purchase of raw material.

Scrap.

The general tone of the scrap steel and old metal market is one of exceptional strength and activity. The continual advance of steel and the encouraging report of the metal situation continues to be a factor that assists in keeping scrap at a high level. The local situation is retaining its strength, but prices are unchanged with the exception of coppers, light having advanced one cent to 22c. per lb., and heavy grade to 26c., the latter having advanced ½c. per lb.

Toronto, Ont., May 22.—While the volume of trade continues satisfactory, the scarcity of raw and semi-finished materials is becoming a serious factor in the situation. Manufacturers are handicapped by their inability to procure the necessary materials for their plants, resulting in a curtailment of production. The coal situation is also causing con-

siderable anxiety, as stocks are low, with prices still advancing. Dealers say that it is a question of supply and demand, and that there is no prospect of cheaper coal this year.

Steel

The situation in the steel trade is getting more complicated owing to the increasingly heavy demand and difficulty which the mills are having in filling orders. With the demand for steel so urgent and deliveries more backward than ever, a more serious shortage than already exists appears to be inevitable. This is especially true as regards ship plates and sections, but applies to practically all steel products. Canadian interests are constantly sending inquiries to the States for steel, but the mills there are so busy that it is very difficult to get the material even at the high prices now obtaining. A report from Buffalo states that a considerable inquiry has developed for bars from Canadian users. Some agencies have been advised by mills not to book orders, except on advice from the mills, until the Government needs have been ascertained. As practically the entire output of the Canadian mills is required for munitions and other war purposes, domestic consumers of steel for manufacturing and similar purposes have to get considerable material from the United States. This source of supply, however, is becoming daily more uncertain owing to the fact that Government requirements take precedence over all other business. As Government buying will undoubtedly be very heavy, the outlook is not very bright for manufacturers using iron or steel.

With such conditions prevailing, it is not surprising that prices continue to climb. There never was a time when supply and demand were so unequal. There is no improvement in the situation in sight, and the upward movement in prices will continue. Wrought pipe has again advanced, this time by \$6 per ton, affecting both black and galvanized material. Boiler tubes, both seamless and lapwelded, have advanced. Many makers of iron and steel tubes are sold up for a year or more, and any mill that can make fairly prompt delivery can get heavy premiums over what are regarded as regular prices for forward delivery. The demand for ship plate is enormously heavy. According to leading authorities in the States, the entire output of ship plates for two years will be required for the Government shipbuilding programme. Sales of several thousand tons of ship plates have been made by Eastern mills at 10c Pittsburgh, while 10.40c was recently paid on 1,000 tons of hull plates by a Canadian interest. Prices of bolts and nuts have advanced.

The heavy demand for all grades of sheets continues, with the scarcity in supply for prompt shipment getting more acute. Many manufacturers have withdrawn from the market, and surplus tonnage has been absorbed by the Government. Prices continue very firm, particularly on blue annealed sheets, which have advanced 25c per 100 lbs. Higher prices on black, blue annealed, and gal-

vanized sheets are expected at an early date.

The principal feature in the steel trade in the United States is the present and prospective Government buying. The Government needs are still indefinite, but are gradually assuming important proportions, particularly for steel plate for the proposed shipbuilding programme. Rolling schedules will likely be considerably disarranged to take care of Government requirements, and the output on this account will be affected. The shortage of cars is restricting the movement of steel from the mills and causing considerable delay to shipments of material to consumers. Prices of semi-finished steel are still advancing. Bessemer and O.H. billets, and O.H. sheet bars are now quoted at \$85 Pittsburgh. Although \$85 is quoted on sheet bars, this material has been sold at \$95 for three-quarter shipments, and \$100 has been paid for small tonnage for nearby shipment.

Pig Iron

The market continues active, with prices still advancing in the States. Local price for foundry pig iron is unchanged at \$50, but an advance is expected any time. At Buffalo the price range now runs at about \$46 to \$47 for this year's delivery, although one producing interest is taking business at less than these figures. The furnaces are unable to furnish all the iron required by consumers, and deliveries are getting behind.

Scrap

While business continues dull, except in cast and steel scrap, there is a firmer undertone to the market and prices show indications of advancing. The high cost of pig iron is raising the value of scrap, while the increased demand is reducing supplies of this material. Prices of scrap lead are very firm, while copper and bars are also stronger.

Machine Tools

There is practically no change to note in the machine tool market. Business during the week has been rather quiet, although there have been a few inquiries received by local machinery houses for machine tools of a general description. Owing to a hitch in the preliminary arrangements, plans for the proposed shipbuilding plant in the Ashbridge's Bay district, Toronto, are held up. It is not definitely known yet if the work will be proceeded with. In the United States, considerable uncertainty surrounds the market for machine tools as the Government requirements are not yet known. Builders are holding back until the situation is clearer.

Supplies

Following an advance of 2c on pure Manila rope, prices of transmission rope and drilling cables are higher. Manila rope is now 33½c, transmission rope 43½c, and drilling cables 38½c per lb. for ¾ in., and larger basis. Packings are also up. Square braided is now 32c, No. 1 Italian 38c, No. 2 Italian 30c per lb. Putty has advanced 25c per 100 lbs., standard in 100 lb. drums being now \$4.35.

Metals

The metal markets are much firmer, and the situation generally has improved. There have been no important price changes, quotations having been maintained at last week's levels. The copper situation is strong and higher prices appear likely. Business is being restricted pending a decision in regard to the American Government purchases, but as these requirements will be considerable, it is probable that prices will advance.

Copper.—The market continues dull and inactive, but quotations are holding firm with a tendency to advance. Little change in the situation in the market in New York is expected until Government business is finally decided. The opinion is generally held that the American Government and Allies will pay from 25c to 27c for their requirements and that the quantity involved will be very large. Local prices are unchanged and nominal, Lake and electrolytic being quoted as 37c, and castings copper at 36c per pound.

Tin.—The market continues strong and prices firm, with a higher tendency. The present upward movement in prices is due largely to a lack of transportation facilities, although some consumers fear a shortage of tin. Tin is quoted at 68c per pound.

Spelter.—Zinc ore recently advanced \$7.50 per ton, which has tended to strengthen the spelter market, especially as future shipments are in good demand with a scarcity of offerings. The market is firm and quotations are unchanged at 12c per pound.

Lead.—The strength of the market is indicated in the "Trust" price of lead, which has advanced \$10 a ton to the basis of 10c New York. The outside market is still higher, ranging from 10.50c to 10.75c, New York, for May and June shipments. In the meantime, lead is unchanged locally at 13.25c per pound.

Antimony.—There is a fairly good demand for antimony. The market is firm with some tendency to advance on offerings for earlier positions than July. In spot antimony the market is firm at 30c per pound.

Aluminum.—There is no change in the position of aluminum and the market is steady on the basis of previous quotations. Present price 68c per pound.

PORT ADVANTAGES OF VANCOUVER, B.C.

THE Secretary of the Vancouver Board of Trade has issued a notice to the effect that the people of British Columbia, and especially of the port of Vancouver, are anxious to promote closer relations with British shipowners. This matter has engaged the earnest attention of their Board of Trade, and at a recent meeting it was resolved to communicate with the leading shipowners in Great Britain with a view to securing, as far as possible, their co-operation. Their desire is to promote the policy of making Vancouver, which is the principal British port in the North Pacific, the headquarters of British shipping on that coast.

It is pointed out that the Dominion Government has just completed a large dock and grain elevator, and further extensive improvements and facilities are planned for shipping, including a large dry dock. The Vancouver Board of Trade has petitioned the Dominion Government to make the harbor of Vancouver a national free port. The harbor facilities will be found equal to any on the coast, but they do not, at this time, wish so much to suggest the exclusive advantages of Vancouver as a loading port as the advantages of establishing a branch office in Vancouver for the management and chartering of vessels engaged in Pacific Coast trade. If shipowners opened their own offices in Vancouver it would be an important help in developing the trade and resources of that Province by putting it more closely in touch with freighting facilities, and, at the same time, it is considered that it would not prejudice but facilitate trading from other ports on the coast.

The actual expense of opening an office in Vancouver, it is thought, would be offset by the greater efficiency of local control, and it is believed that a measure of decentralization would both promote the solidity of the Empire and the interests of British shipowners. Amongst the advantages put forth are: The proximity of the best bunker coal on the coast. The ability to co-operate with Canadian railroads, and to divert to this British port much traffic, which can be shipped to advantage by way of Vancouver to and from the Orient, including Asiatic Russia and Australia; the adequate facilities and low port charges of Vancouver.



BRITISH TRADE CORPORATION

HON. ALBERT STANLEY, President of the Board of Trade, stated in the House of Commons a few days ago, that the British Trade Corporation would have a capital of £10,000,000. It was proposed to raise £2,500,000, and it was necessary that one million should be subscribed before the prospectus was issued. He had interviewed representative bankers, he said, explained the scheme to them and asked their support.

The banks were practically unanimous in support of the scheme, although he could not say that all of them were equally enthusiastic in agreeing to subscribe capital. A number of the larger banks had subscribed towards the million which was necessary in order to launch the scheme. The Government did not propose to subscribe capital or subsidize the undertaking in any way. He believed the corporation would serve a very useful purpose.



STEEL MILL AND CENTRAL STATION

By K. A. Pauly.

A FACT, not generally appreciated, says K. A. Pauly in the *General Electric Review*, is that the power requirements of the large and even the moderate mills exceed those of any other

industrial field of motor application. For example, the main rolls of the rail mill at Gary are driven by six induction motors having a combined rated capacity of 24,000 h.p., with a maximum momentary capacity of approximately 80,000 h.p., and the main rolls of the billet mill at the same works are driven by five motors with a combined capacity of 22,000 h.p. with a corresponding maximum momentary capacity. Then, too, we have the large reversing mills which are driven by motors from 2,000 h.p. to 7,000 h.p. taking peaks from 6,000 to 20,000 h.p. momentarily. In addition to the power taken by the main rolls there are a very large number of smaller motors scattered about the plant for driving all manner of auxiliaries required for unloading the ore and transferring it to the blast furnaces, driving the blast furnace auxiliaries, and for transferring the iron and steel from the time it is drawn from the furnace until it is shipped as finished shapes.

The station load diagram of a steel plant is the result of a combination of load curves of almost every conceivable shape ranging from the extremely intermittent cycles of the large motors driving single stands of rolls and the small motors operating the screw downs, lifting tables, etc., to the more or less constant loads of the larger motors driving multi-stand mills, blast furnace pumps, gas washers, etc. The load factor of a central station supplying a steel mill obviously varies with the magnitude of the plant, although that for small plants is higher than might at first be expected owing to the fact that most small works do most of their rolling in multi-stand mills, roll smaller sections, and take more passes to produce a given reduction. Further, the steel is of such length that it is looped in rolling and passes simultaneously through several stands of rolls, and in many mills several pieces are rolled at the same time, thus producing a much more uniform load than obtains with the large single stand mill.

When power is purchased at a rate which is dependent upon the peak demand as well as the energy consumed or where power is supplied from a comparatively small central station means can frequently be provided for reducing the fluctuations in the load, but as the method of accomplishing this result depends upon a variety of local conditions the various methods will not be discussed here.

Group Relation to Central Station

From the standpoint of the central station, steel mills can conveniently be divided into two groups. In the first are included those companies which operate their own blast furnaces, and in the second group those which purchase their steel in the form of ingots, billets, or slabs, etc., for rolling and fabricating works which purchase the rolled shapes. Although a few of those included in the first group do at present and probably will continue to purchase power to supplement that which is developed locally, the large majority of these companies have made and will continue to make all

their own power as a by-product, and many have a surplus to sell. The following figures taken from a paper read before the A.I.E.E. in 1909 will serve to indicate the immense amount of energy available as a by-product incident to the manufacture of steel.

As a result of the reduction of the iron ore in the blast furnace there is produced in the form of so-called waste gases approximately 150,000 cu. ft. of gas having an average thermal value of approximately 90 B.t.u. per cu. ft. Of this approximately 30 per cent. is required for heating the hot blast stoves and approximately 25 per cent. for driving the blast furnace blowing engines, gas washing machinery and auxiliaries used in connection with the blast furnaces and blowing engines, leaving 45 per cent. or approximately 320 kw-hr. per ton of pig iron produced available for general power purposes. Also, many of the large steel plants are manufacturing the coke used in the blast furnaces which reduce the ore at the works and have available as a by-product of the coke ovens approximately 10,000 cu. ft. of gas having approximately 500 B.t.u. per cu. ft., of which approximately 50 per cent. or approximately 130 kw-hr. per ton of coke produced is available for general power purposes elsewhere in the mill. As very nearly a ton of coke is required to produce a ton of pig iron in the blast furnace, the by-product power available for general purposes from the blast furnace and coke oven gases is obviously approximately 450 kw-hr. per ton of pig iron. Also in many steel plants considerable additional power is being obtained from waste heat boilers used in connection with the open-hearth furnaces. While the power from this source is small compared with that from the blast furnace and coke oven gases, it is very considerable when compared with many industrial plants, and has an appreciable effect in lowering the cost of producing power in the large modern steel works.

Type of Equipment Installed

There seems to be a feeling inbred into the minds of steel mill men that 60-cycle equipment is not at all suited to steel mill conditions. The foundation for this is doubtless to be found in the fact that all or practically all of the large steel works throughout the country have adopted 25-cycle as the frequency of their power systems. This prejudice is frequently a serious handicap to the public service power solicitor who is trying to interest the steel company in his goods which he can offer only at 60 cycles. Many of the constant speed auxiliaries about the mill are driven by induction motors and with 60 cycles more speeds are available than with 25 cycles, there being seven speeds from which to choose within the range of 500-r.p.m. and above with the former frequency and only three with the latter. Also most of the equipment, such as motor generators, transformers, etc., are cheaper for 60 cycles and equally efficient and reliable. 25 cycles, however, has considerable advantage over 60 cycles for supplying the

slow speed, direct connected, main roll motors, the power factor of such motors usually being higher for the same overload capacities and their costs less.

The difficulty of operating gas engine-driven generators at 60 cycles has also been an important factor in bringing about the adoption of 25 cycles by the large steel plants. There is, however, no fundamental reason why motors cannot be designed for 60 cycles to meet the severe rolling mill requirements, and any one of the large electrical manufacturers will readily guarantee such motors to develop the necessary overloads and to operate within any specified heating limits. The power-factor of the slow speed, 60-cycle machines is as previously stated lower than for 25-cycle units, but this defect can be neutralized by synchronous condensers. It is a fact, however, that most of the mills in the plants which fall in the second group are of the size and type which it is customary to drive either through gearing or rope transmission, thus permitting the use of motors of moderate speeds for which 60 cycles is at least as satisfactory, if not slightly preferable; so that in general it may be said that 25 cycles possesses little, if any, advantage over 60 cycles as a steel mill frequency for those plants which will consider purchasing their power.

Conclusions Drawn

As in the general treatment of all similar problems no definite recommendations can be made which will conform to all the special conditions which may surround any particular case. However, in summing up, the writer feels safe in drawing the following conclusions from his experience in this field of application of electric power. First, that if for reasons other than the question of frequency, the power for supplying the plant is to be developed locally, 25 cycles should be chosen as the operating frequency, except possibly in the case of some small plants referred to below. Second, that for plants falling in the second group, if reliable power can be purchased at a reasonable rate, which the writer believes is always the case, the mill frequency should be that of the available source of supply whether 25 or 60 cycles and the necessary power purchased, unless for reasons other than those having a direct bearing on the power problem, it is considered expedient to generate rather than purchase power. It is conceivable that it might be to the interest of the steel company to operate its own plant, although from power considerations alone this would seem unwise, and in such cases the adopted frequency should in general be the same as that of the local public service company so that in the event of a breakdown assistance can be obtained from the local company.

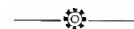

SENTINELS OF THE DEEP

By Capt. Geo. S. Laing

TO a great many people an island is a piece of land surrounded by water, but to those who "go down to the sea in ships," an island is an ocean oasis. This article will refer to

lonely islands far removed from the main continents.

Island of St. Helena.

Is there at the present moment a sea-girt rock that has more historical value wrapped up in its precipitous cliffs than grand old St. Helena? Could one view a more inaccessible mountain-top rearing its bald iron pate above the South Atlantic Ocean? No thinking person could leave memories of this stronghold buried in the mind's vaults to rot. Inspiration simply radiates from such an island.

To fully appreciate the value of an island it is necessary to imagine that you are in the shoes of a shipwrecked sailor, naval strategist, or cable company director. These are a few of the men who circle round ocean islands lying maybe from 500 to 1,500 miles away from the next island or continent. St. Helena is situated in latitude 15° 55' south, and longitude 5° 44' west. The southeast Trade Winds blow over it all the year round and roughly it is 1,000 miles from the African coast and twice that distance from South America. If it were imperative for any native of St. Helena to change foot-stools, his nearest neighbor would be the island of Ascension some 700 miles to the northwest and nearer the Equator. Take St. Helena from a sailor's point of view first.

We are homeward bound from Java, India or Mauritius in a sailing ship and have come round the Cape of Good Hope. In some cases we may not have seen land for two months and suddenly a man from aloft hails the deck with the words, "land on the lee bow, sir." In the morning glory of the tropics, the island—still forty miles away—looks like a tiny rain squall kissing the ocean from a surrounding clear sky. To those who have never lost sight of dry land its presence is commonplace, but the sighting of this little ocean rock kindles a fire in the thoughts of seamen, just as an Atlantic passage in a palatial steamboat becomes a revelation to thousands of land folks.

St. Helena's Inhabitants

Our craft is sailing along at six or seven miles an hour, with yards a little canted to port. The rain squall effect soon takes on a definite outline and the island now resembles a gasometer. Towards afternoon our craft is sailing along under the very frown of the island cliffs and two or three native whale-boats are towing from our lee rail. Their shades in features denote that the peon classes of this island are drawn from more than one or two original clans of black and white. One pleasant thing to note is their clean overalls of blue cotton, for apparently the island people believe in soap and water having a big say in their lives.

They have fish, vegetables, fruits and curios for sale, and one man from each boat comes on board while the others remain to bend on to a rope what may be hauled on deck. If our voyage has

been long, appreciation of fresh vegetables and fruits is great. The curios consist of ladies' wrist bangles made from elephant grass seed or shells, and chatelaines of the same materials. Perhaps the "best seller" is a booklet of blank paper with ferns, mosses and yellow daisies sewn between the leaves. As these plants have been grown on the ground surrounding Napoleon's grave, their value remains with one for ever, and stirs up many allied associations of land and sea. As this is written, the writer is looking upon some dried ferns and moss that he brought from this historical rock in 1890, so age would appear to work slowly with such stuff.

We now open out the lee side of the island and can see the Ladder Hill. The stairway with its 700 steps is very plain and appears like a white-washed streak from sea to mountain top. There is an anchorage under the only town—James-town, but unless we had sickness on board, or had run short of drinking water we generally sailed right on to wards the next peak—Ascension.

A Natural Fortified Island

St. Helena is heavily fortified by Nature as it has only one safe landing

CANADIAN GOVERNMENT PURCHASING COMMISSION

The following gentlemen constitute the Commission appointed to make all purchases under the Dominion \$100,000,000 war appropriation:—George F. Galt, Winnipeg; Hormidas Laporte, Montreal; A. E. Kemp, Toronto. Thomas Hilliard is secretary, and the Commission headquarters are at Ottawa.

place and that is very limited. Its precipitous rise from the ocean, with the exception of this small shelf for anchorage water, makes it a most defiant place. Napoleon was as safe on this rock as far as escape was concerned as one could possibly be. All together this warrior lived seven years in his island prison, and his ashes rested in St. Helena for nearly twenty-one years before they were given to France for re-interment in Paris.

The native boats have gone their way, we have taken solar observations to check our chronometers, while old St. Helena dips into the ocean astern. Although the island can only receive a short innings in such an article as this, it should be said, that from the sea one can find no trace of flora, but those who know the rock from its hidden interior tell us that woods, pasturage and foliage abound behind its iron rock-bound cliffs.

Ascension Island

Ascension is another valuable island. In raising this island from the South, the conical shaped mountain of rock and sand looks as hot and blistered as the

shores of Suez or Aden in their desert ovens. We generally signal the vessel's name and port of registry to the flag station on the slope of the peak. This island is invaded sometimes by "rollers" which are huge crestless waves, twenty to thirty feet in height, rolling inshore at a good velocity and breaking like wild cascades on the beach, these unwelcome ocean babies make anchorages unsafe; but again, an island's value is wrapped up in such things. As a cable station and a naval and military possession, our Empire could do with more such places. Their isolation and inaccessibility are gems when it comes to strategic movements, alike in commerce, war, and communication.

Sea turtles visit the shores of Ascension and paddle themselves aground; then with flippers dug into the sand these peculiar creatures crawl slowly to a point ten or twenty feet above high water mark. Here, instinct tells them to scoop out a hole two or three feet deep and deposit the eggs for old sol to hatch. As a layer, the turtle will take some beating, for one nest often contains 70, 80 or 100 eggs. The lady turtle only asks one quiet evening ashore to discharge her egg consignment, and as the sun is rising next morning she is launching her bath-tub body into the sea for another long trip in ballast.

This it is, that lonely rocks and islands in mid-ocean have a great value, although from a mineral or agricultural point of view they may be worthless. Bermuda and Sable island are our lonely islands in the North Atlantic, but wherever they may be, their value to a maritime nation is beyond reckoning.



CATALOGUES

Buffing Machinery.—The Chase Turbine Mfg. Co., Orange, Mass., have issued a bulletin describing and illustrating two styles of buffing and polishing machines. A specification is included covering the principal features.

Barker Chucks.—The Thomas Elevator Co., Chicago, Ill., have issued a binder containing six bulletins, A to F inclusive, dealing with various types of "Barker" chucks. Bulletin D describes a wrench operated chuck while the other bulletins deal with different types of wrenchless chucks. Each type is carefully described and its principal constructional features shown by means of sectional views and diagrams.

Tool Book No. 13.—The Goodell-Pratt Co., toolsmiths, of Greenfield, Mass., have published a new edition of their tool book. This complete pocket catalogue, which is a new issue, shows every article which the company manufacture and cancels all previous editions. It covers an extensive line of tools and devices for mechanics, artisans and amateurs, comprising altogether 432 pages. All the tools, etc., are illustrated and are also briefly described.

Enlarged Canadian Trade Intelligence Service

Under the arrangement made by the Minister of Trade and Commerce with Sir Edward Grey in July, 1912, the Department of Trade and Commerce, Ottawa, is able to present the following list of the more important British Consulates whose officers have been instructed by the Foreign Office to answer inquiries from and give information to Canadians who wish to consult them in reference to trade matters.

BRAZIL—Bahia, British Consul. Rio de Janeiro, British Consul General.	NETHERLANDS—Amsterdam, British Consul.
CHILE — Valparaiso, British Consul General.	PANAMA—Colon, British Consul. Panama, British Vice-Consul.
COLOMBIA — Bogota, British Consul General.	PERU—Lima, British Vice-Consul.
ECUADOR—Quito, British Consul General. Guayaquil, British Consul.	PORTUGAL—Lisbon, British Consul.
EGYPT — Alexandria, British Consul General.	RUSSIA—Moscow, British Consul General. Petrograd, British Consul. Vladivostock, British Consul. Odessa, British Consul General.
FRANCE—Havre, British Consul General. Marseilles, British Consul General.	SPAIN—Barcelona, British Consul General. Madrid, British Consul.
INDIA—Calcutta, Director General of Commercial Intelligence.	SWEDEN—Stockholm, British Consul.
ITALY—Genoa, British Consul General. Milan, British Consul.	SWITZERLAND—Geneva, British Consul.
MEXICO—Mexico, British Consul General.	URUGUAY—Monte Video, British Vice-Consul.
	VENEZUELA — Caracas, British Vice-Consul.

Canadian Commercial Intelligence Service

The Department of Trade and Commerce invites correspondence from Canadian exporters or importers upon all trade matters. Canadian Trade Commissioners and Commercial Agents should be kept supplied with catalogues, price lists, discount rates, etc., and the names and addresses of trade representatives by Canadian exporters. Catalogues should state whether prices are at factory point, f.o.b. at port of shipment, or, which is preferable, c.i.f. at foreign port.

CANADIAN TRADE COMMISSIONERS.

ARGENTINE REPUBLIC—E. S. Webb, Acting Canadian Trade Commissioner, Reconquista, No. 46, Buenos Aires. Cable address, Canadian.
AUSTRALIA—D. H. Ross, Stock Exchange Building, Melbourne. Cable address, Canadian.
BRITISH WEST INDIES—E. H. S. Flood, Bridgetown, Barbadoes, agent also for the Bermudas and British Guiana. Cable address, Canadian.
CHINA—J. W. Ross, 13 Nanking Road, Shanghai. Cable address, Cancom.
CUBA—A. T. Quilez, Acting Canadian Trade Commissioner, Lonja del Comercio, Apartado 1290, Havana. Cable address, Cantracom.
FRANCE—Phillipe Roy, Commissioner General, 17 and 19 Boulevard des Capucines, Paris. Cable address, Stadacona.
JAPAN—E. F. Crowe, Acting Canadian Trade Commissioner, P. O. Box 109, Yokohama. Cable address, Canadian.
HOLLAND—P. H. Geleerd, Acting Canadian Trade Commissioner, Zuidblaak, 26, Rotterdam. Cable address, Watermill.
RUSSIA—C. F. Just, Canadian Government Commercial Agent, Alexandrinskala, Plosch 9, Petrograd. L. D. Willgress, Canadian Government Commercial Agent, Bukhgozla Ulitza No. 4, Omsk, Siberia.
NEWFOUNDLAND—W. B. Nicholson, Bank of Montreal Building, Water Street, St. John's. Cable address, Canadian.
NEW ZEALAND—W. A. Beddoe, Union Buildings, Customs Street, Auckland. Cable address, Canadian.
SOUTH AFRICA—W. J. Egan, Norwich Union Buildings, Cape Town. Cable address, Cantracom.
UNITED KINGDOM—Harrison Watson, Sub-division E.C., 2, 73 Basinghall Street, London, E.C., England. Cable address, Sleighing, London. N. D. Johnston, Sun Building, Clare Street, Bristol. Cable address, Canadian. J. E. Ray, Central House, Birmingham. Cable address, Canadian. J. Forsyth Smith, 31 North John Street, Liverpool. Cable address, Cantracom. F. A. C. Bickerdike, 4 St. Ann's Square, Manchester. Cable address, Cantracom. J. Forsyth Smith, Acting Canadian Trade Commissioner, 87 Union Street, Glasgow, Scotland. Cable address, Cantracom.

CANADIAN COMMERCIAL AGENTS

AUSTRALIA—E. Millin, Royal Exchange Building, Sydney, N.S.W.
BRITISH WEST INDIES—Edgar Tripp, Port of Spain, Trinidad. Cable address, Canadian. R. H. Curry, Nassau, Bahamas.
NORWAY AND DENMARK—C. E. Sontum Grubbegd No. 4, Christiania, Norway. Cable address, Sontums.
SPAIN—J. F. Roberts, Care British Consulate General, Barcelona.

CANADIAN HIGH COMMISSIONER'S OFFICE

UNITED KINGDOM—W. L. Griffith, Secretary, 17 Victoria Street, London, S.W., England. Cable address, Dominion, London.

Duriron, a non-corrosive metal, is the subject of Bulletin No. 100, recently issued by the Duriron Castings Co., Dayton, Ohio. The bulletin first describes the chemical and physical properties of "Durion," which is of acid, alkali, and rust proof metal. The succeeding pages contain illustrations and descriptive matter covering "Durion" standard pipe, drainage pipe, fittings, valves, cocks, pumps, blowers, etc. The concluding pages show illustrations of miscellaneous equipment such as tanks, condensers, stills and kettles, etc.

BOOK REVIEW

Jane's Fighting Ships, 1916, by the late Fred T. Jane, 449 pages, 12 x 7½ in. Published by Sampson Low, Marston & Co., London, England, price \$5.25. This well known encyclopedia of the navies of the world is now in its nineteenth year of issue. This edition is new and complete, and has been sanctioned by the British Admiralty. In this edition the details of the British Navy have been reinstated, but without photographs and illustrations, and omitting, of course, any feature that might be of assistance to the enemy. The changes in this issue are suggestions of the late Mr. Jane, and have been carried out under the direction of Maurice Prendergast. A large number of new illustrations in the form of photographs, plans and silhouettes have been added, while many new maps of ports and harbors, brought into prominence by the war, have been included. Sections devoted to various navies have been enlarged and generally improved, while some very useful information has been included on German submarines. In spite of the restrictions imposed by the war, the book contains a great deal of valuable and interesting information. In regard to the British ships, although the illustrations and silhouettes have of necessity been omitted, particulars covering armament, machinery and general features are included. A list of illustrations of ships of all nationalities lost in the war is contained in the opening pages. The book has a list of contents and a general index, the latter being a list of ships of all navies. Additional to the 449 pages of reading matter are 161 pages of advertisements forming useful directory of shipbuilders and manufacturers. The book is printed on coated paper and bound in substantial card-board covers.

Seventeen men were waiting in line at a ticket window in a railway station when an excessively inebriated person thrust himself at the head of the line and shoved thirty-five cents before the ticket agent.

"Gimme ticket f' New York," he said. "You can't go to New York on thirty-five cents," answered the agent.

The exhilarated man wavered a moment, and then was struck with a brilliant idea.

"Say," he asked, "where can I go for thirty-five cents?"

And seventeen men told him.

GOULD & EBERHARDT SHAPERS in Stock

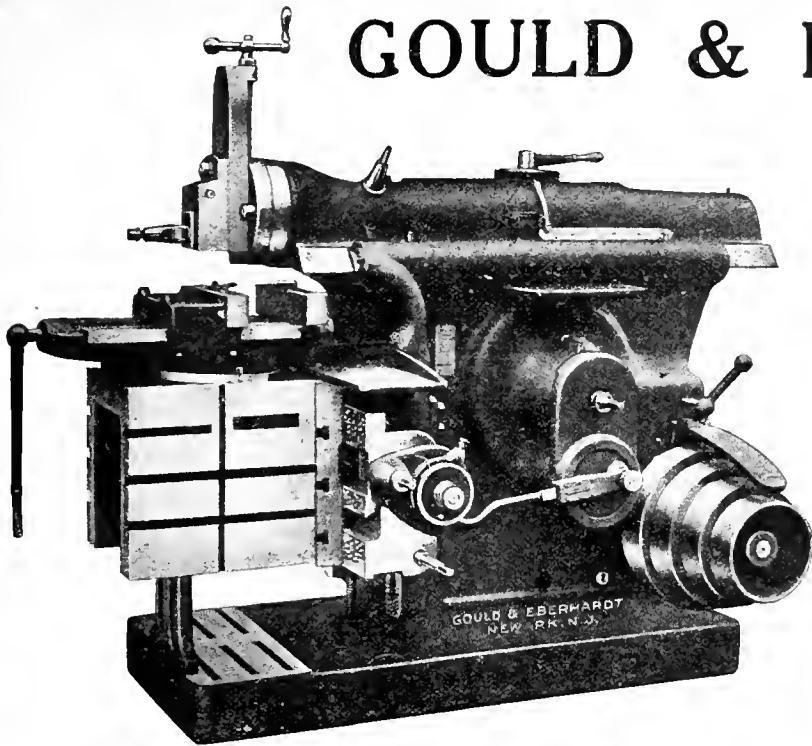

20" and 24" Sizes

28" "Invincible" July delivery

Write for literature describing the Double Triple Quick Stroke and other original features.

IMMEDIATE SHIPMENT.

The A. R. Williams Machinery Company, Limited

ST. JOHN, N.B.
WINNIPEG, VANCOUVER

"If It's Machinery, Write Williams"

64 Front Street West,
TORONTO

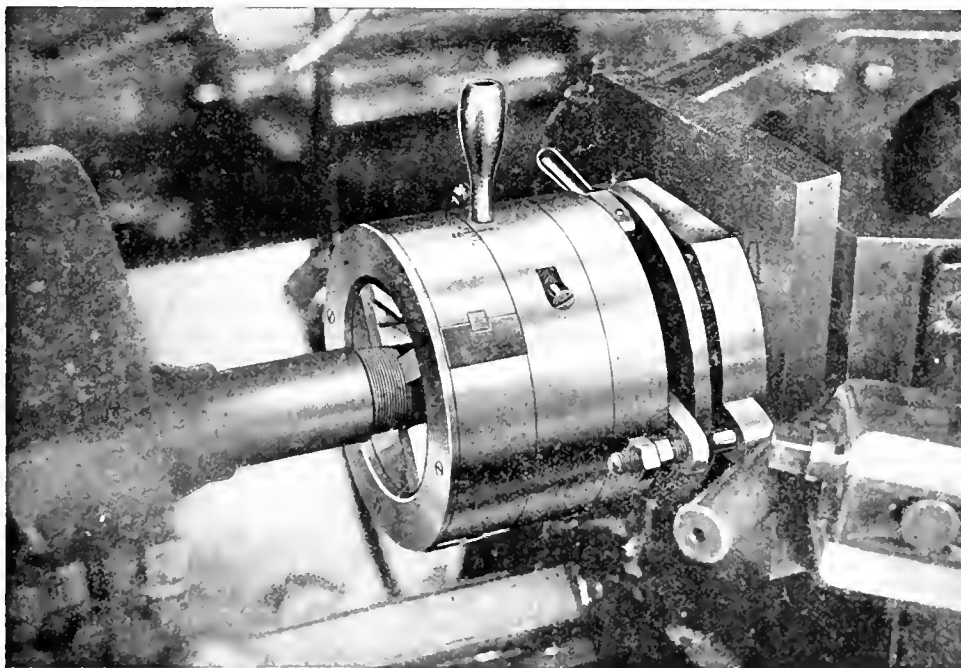

**A GEOMETRIC
STYLE D-D DIE
HEAD**
at work for the
**ANDERSON ELECTRIC
CAR CO.**

The turret on the machine that carries this die head is excessively large and heavy. No trouble is experienced on this part, for with the Geometric style "D-D" type of die head, it is not necessary for the operator to follow the thread closely. Two sets of compensating springs give perfect threads at the start and cause the dies to follow the lead properly.

What can we do for you. We are at your service. So are our Thread-cutting Tools.

The Geometric Tool Company, New Haven, Conn., U.S.A.

Canadian Agents :

Williams & Wilson, Ltd., Montreal. The A. R. Williams Machinery Co., Ltd., Toronto, Winnipeg, St. John, N.B.

If any advertisement interests you, tear it out now and place with letters to be answered.

INDUSTRIAL ^A_N^D CONSTRUCTION NEWS

Establishment or Enlargement of Factories, Mills, Power Plants, Etc.; Construction of Railways, Bridges, Etc.; Municipal Undertakings; Mining News

ENGINEERING

Therold, Ont.—The Exolon Co., manufacturers of artificial abrasives, contemplate adding another unit to their plant here.

Toronto, Ont.—The Etobicoke Township Council propose to build an electric light plant to supply current to the district.

Bridgeburg, Ont.—A firm of motor truck manufacturers of Brazil, Ind., is contemplating locating a branch factory here.

Bala, Ont.—The Bala Electric Light & Power Co. will build a power plant. Grant & Thorpe, of Peterborough, are the general contractors.

London, Ont.—Steel Lockers, Ltd., a concern recently incorporated, plan to build a factory here for making metal lockers and furniture, etc.

Orillia, Ont.—The Inland Construction Co., are making fair progress with the new power development at Swift Rapids. The first of the three 1500 k.w. generators has been delivered.

St. Catharines, Ont.—A by-law has been passed by the City Council to sell a site to the Turnbull Electro-Metals, Ltd., for factory purposes. The sale is subject to the erection of a plant within two years.

St. Thomas, Ont.—The Dominion Brakeshoe & Foundry Co., whose plant is being finished expects to commence operations within the next three weeks. The local branch is the first foundry of the American Brakeshoe Co. to be started in Canada.

Vancouver, B.C.—Plans for the construction of a \$10,000,000 iron and steel plant in the vicinity of Vancouver are being made by a group of financiers according to a letter submitted to the City Council recently by Industrial Commissioner J. R. Davison.

Regina, Sask.—According to information received here, the Federal Government will expend \$300,000 in developing the lignite fields of Saskatchewan at Estevan. The development of those fields will solve the fuel question of this Province, it is believed, and prevent coal famines that have caused as much inconvenience during the past few winters.

MUNICIPAL

Tillbury, Ont.—The Town Council contemplate installing a pumping plant. Engineer, J. J. Newman, Windsor, Ont.

New Liskeard, Ont.—A by-law to raise \$6,000 for the sinking of three new wells has been passed by the Council.

Trail, B.C.—The City Council propose spending \$80,000 for extensions to the

waterworks plant. A by-law will be voted on.

Hespeler, Ont.—A by-law to raise \$14,000, to provide for extensions to the waterworks system, has been passed by the ratepayers.

Elmira, Ont.—It is proposed to grant a loan of \$15,000 to the Elmira Machinery & Transmission Co., who will build an extension to their factory.

Davidson, Sask.—The Town Council propose purchasing a power plant and making improvements to same. The total cost is estimated at \$4,300.

Oshawa, Ont.—The Board of Works have submitted their report recommending the purchase of a new sprinkling wagon at a cost not to exceed \$425.

Oshawa, Ont.—A proposal has been laid before the Council that a bonus to the extent of \$15,000 be given to the W. T. Trick Co., and the assessment fixed at \$10,000.

Ford, Ont.—A by-law will be voted on by the ratepayers to grant exemption from taxation to the Chalmers Motor Co., who are rebuilding their plant which was recently damaged by fire.

Port Dover, Ont.—A water works system and sewage system are being considered for Port Dover, the approximate cost being put at \$65,000. It is likely that a by-law will be submitted to the people in August next.

Smiths Falls, Ont.—G. F. Drewery, one of the Hydro engineers, is in Smiths Falls to investigate the two local electric plants and to make an estimate of what it would cost the town to buy them. This, he says, is the first step in getting hydro electric power for Smiths Falls, and he will report to Council as soon as he completes his inspection of the plants.

Windsor, Ont.—Mayor Tuson, of Windsor, at a meeting of the Essex Border Utilities Commission, held on May 18, expressed himself as strongly opposed to Morris Knowles, consulting engineer for the commission, being allowed to go ahead with plans for a temporary sewage system to serve Windsor and other border municipalities, including Ojibway, until the scheme had received the approval of ratepayers of each municipality.

Tillsonburg, Ont.—The ratepayers of the town defeated two industrial propositions at the polls on May 15, both failing to get the two-thirds necessary vote. The Tillsonburg Foundry & Machine Co. asked for a loan of \$10,000 for five years at five per cent., a free site and a fixed assessment of \$2,000 and agreed to employ 30 to 50 hands. The Canadian Cereal & Flour Mills sought a fixed assessment on their mills

here of \$30,000 and agreed to employ 30 to 50 hands in the oatmeal and pea mills for a period of five years.

GENERAL

Montreal, Que.—The Eureka Toy Co., Maisonneuve, Que., is preparing to build a factory to cost \$85,000.

Montreal, Que.—The Hamilton Cement Co., in which Claude Bordier, Montreal, is interested, will build a plant at Point aux Trembles, Que., for the manufacture of cement, cement products, etc.

Markham, Ont.—The Markham Woolen Mills were struck by lightning and destroyed by fire on Saturday. The damage to building and machinery, etc., is estimated at \$100,000, which is partially covered by insurance.

Kincardine, Ont.—The Watson by-law carried here by a majority of 41 over the necessary three-fifths. The people have, by their vote, decided to loan J. B. Watson \$20,000 to assist in the establishing of another furniture factory here.

Galt, Ont.—This city has another new concern, the Galt Building Products, Ltd., which will manufacture, by a patent process, sand brick tile, artificial marble and other building materials. The company has secured eight acres of land, and expects to commence filling orders by June 1. The new industry has a provincial charter, and is capitalized at \$40,000. E. S. Tolmie is the president.

CONTRACTS

Winnipeg, Man.—The Deputy Minister of Public Works has let a contract to the Canadian Westinghouse Co., for motor generator sets, at \$28,360.

Wolseley, Sask.—The Town Council have awarded a contract for a generator and exciter to the Canadian Westinghouse Co., of Hamilton.

Toronto, Ont.—The Standard Chemical Co. have awarded a contract for 1,500 gallon per minute duplex pump to the Bawden Pump Co., Toronto.

Hamilton, Ont.—The Canadian Engineering & Construction Co., Hamilton, have been given the general contract for a \$75,000 factory for the National Abrasive Co., of Boston, Mass.

Winnipeg, Man.—The Provincial Government has awarded the contract for the supplying of motor generators for the central power house, to the Canadian Westinghouse, Co. The contract price is \$28,360. The Northern Electric Co. was awarded the contract for the lead covered cable and pot heads at a price of \$10,000. The apparatus will generate and conduct power from the central power house, behind the new law courts,

to the new Parliament Buildings and the Law Courts Building.

PERSONAL

W. C. Kennedy, president of the Windsor Gas Co., Windsor, Ont., has resigned in favor of T. P. Pinckard.

C. U. Peeling, of Oshawa, Ont., has been appointed manager of the Cornwall Street Railway, Light and Power Co., and the Stormont Electric Light and Power Co., in succession to Wm. Hodge, who has tendered his resignation after twelve years service.

C. L. Leighty, now inspector of transportation for Eastern Lines, with headquarters at Montreal, has been appointed superintendent of Canadian Pacific Telegraphs, Ontario Division, with headquarters at Toronto, vice H. J. Lillie, who has been assigned to other duties.

M. J. Butler, managing director of Armstrong Whitworth Ltd., Montreal and D. A. McDougall, general manager of the Dominion Steel Corporation Sidney, N.S. have had conferred upon them the honorary degree of LL.D., at St. Francois Xavier University, Antigonish, N.S.

F. P. Gutelius, general manager of the Intercolonial Railway, had been offered the vice-presidency of the Delaware & Hudson Railway. Mr. Gutelius before joining the Intercolonial, was for many years a general officer in the engineering and operating departments of the C.P.R.

Almond Penfield Turner, formerly president of the Canadian Copper Co., a subsidiary of the International Nickel Co., died last Friday in Oakville, Ont., at the age of fifty-two, from Bright's disease. The late Mr. Turner spent most of his life in Cleveland, but was in Copper Cliff, Ont., for ten years, with the Canadian Copper Co., joining the company in a junior position and rising to the presidency. He retired five years ago on account of ill-health.

BUILDING

Montreal, Que.—Tenders for the proposed new Maisonneuve School for Boys on Pie IX. avenue, have been opened and the construction of four new schools to comprise 46 classes authorized at the regular meeting of the Catholic School Commission. C. A. Reeves, architect.

Winnipeg, Man.—City Building Inspector Rodgers has submitted plans for a proposed extension of King Edward Municipal Hospital to the Board of Control. He estimates the cost, including certain alterations to the present structure, at \$22,589. Council will be recommended to order the work proceeded with.

MARINE

Vancouver, B.C.—A contract for the first ship to be built on the North Arm of the Fraser River has been signed by Messrs. Harrison & Lamond, contractors, and the Dominion Government, and

calls for a wooden ship 225 feet long and 44 feet beam. It will cost \$225,000.

St. John, N.B.—Thomas V. S. Dickson, of Glasgow, Scotland, representing a Clyde shipbuilding firm, and A. D. Swan, of Montreal, have been in St. John and Halifax recently, looking over the ground to ascertain the possibilities of establishing a shipbuilding plant.

Vancouver, B.C.—For the purpose of having her coal-burning system changed to handle fuel oil, the steamer Quadra, formerly a Government lighthouse tender, but now owned by a Howe Sound mining concern, is at Vancouver. The alterations will be made by the North Shore Iron Works.

Sault Ste. Marie, Ont.—The Canadian freighter, W. Grant Morden, which went ashore Friday morning, was released on Sunday by the tug Manistique and passed down on her way to Lake Erie. She is undamaged. Downbound steamers report that ice field extends out into Lake Superior for a distance of 75 miles from Parisian Island. Boats are recommended to keep to the north passage.

Vancouver, B.C. The steel steamer War Dog, the first ship of its type to be built in British Columbia, was launched at the Wallace Shipyard on May 17. The War Dog, with a length of 315 feet, 45 feet beam, and a depth of 27 feet, is the first steel cargo vessel to be built in this province, and the contract was placed by a Japanese steamship company through an English firm. Since the steamer has taken to the water she has been sold to a British firm of Liverpool, believed to be the Cunards.

St. Clair Ship Canal Approved.—Word has been received in Sarnia that the International Joint Commission in session at Detroit have approved the proposed ship canal through the St. Clair River opposite this port, all objections on the part of the Canadian officials having been satisfactorily met. The Canadian and American engineers were instructed to begin work on the project at once, and the estimated cost is \$92,000. The channel will be dredged from the mouth of the Black River to the St. Clair River tunnel, and will be used by up-bound steamers.

Victoria, B.C.—The Drummond Light-erage Co., of Seattle, which recently sold the big ear barge to the C.P.R. Co., has awarded contracts for two 800-ton scows to William F. Sehms, shipbuilders, of Port Hadlock. The vessels are to be 120 feet long with a beam of forty feet and a depth of ten feet. With their completion, the Drummond company will have a total of eighteen scows in operation in the Puget Sound-British Columbia freighting business, the eighteen having a combined tonnage of nearly 10,000 tons.

New Westminster, B.C.—Wooden ships to the value of approximately one million dollars will be constructed at New Westminster and at other points along the Fraser River according to a contract just let by the Dominion Government. The allotment of the contracts will not



Let CANADIAN MACHINERY Sell It for You.

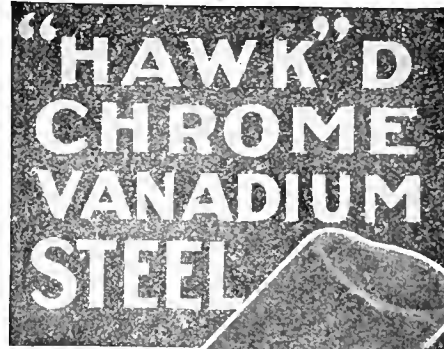

Will Give You Exceptional

Shell Forging Production

WITHOUT AN EQUAL FOR BOTH FIRST AND SECOND OPERATION PUNCHES.

Comes to you heat-treated and ready for use.

It does not stick to the work.

There are many cases where each punch has turned out over 2,000 shells.

It means more shells, per machine per day.

STEEL OF EVERY DESCRIPTION.

Hawkrige Brothers Company

303 Congress St., BOSTON, MASS. U. S. A.

PURO

(MADE IN CANADA.)

Saves Dollars

Why let that old-fashioned faucet go on year after year wasting water—**MONEY**? Why more drinking cups and glasses, only to become un sanitary—lost, broken or carried away? Puro Sanitary Drinking Fountain stops all this needless waste. Puro saves you 3/4 on the water bill alone. Puro saves you all that money you spend for cups. **YET** Puro is always ready with a clear, cool drink with dollars in the bank.

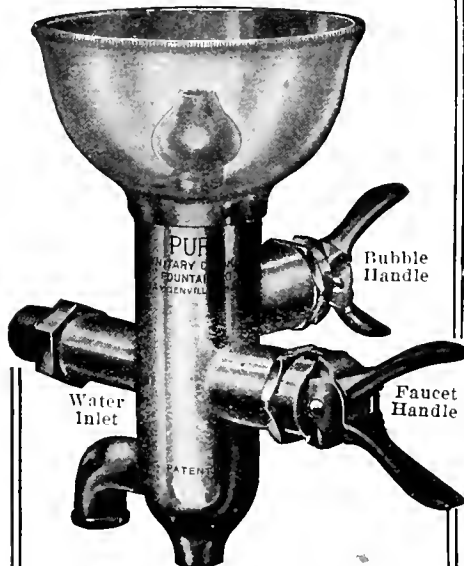

Puro Pays for Itself

You don't have to wait years to get back the small investment you have tied up in Puro equipment—

You start cashing in at once—not only on your water bill saving, but on the increased efficiency of your workers as well.

Men like Puro—it's clean. No danger of deadly germs lurking in its sparkling bubble. Write us—tell how many men, how many departments, and we'll tell you how much the cost will be to

"PURO - FY"

YOUR WATER SUPPLY

Puro Sanitary Drinking Fountain Company
147 University Ave., Toronto, Canada

Help Wanted

An ad for help in the Classified Advertising Section will bring the right kind of replies.

Try It Out.

Canadian Machinery

Classified Advertising Section

143-153 University Ave., Toronto

be completed until after the Dominion Shipbuilding Commission for British Columbia reaches the Pacific Coast. It is understood that if satisfactory terms are arranged at least two and possibly more ships will be built in New Westminster shipyards. The yards at Coquitlam on the Pitt River will also probably be enlarged and used in connection with this ship construction programme as well as at Eburne and other down-river points.

INCORPORATIONS

The British American Rubber Co., has been incorporated at Ottawa, with a capital of \$250,000, to manufacture rubber goods and supplies. Head office is at Toronto, and the incorporators are Gordon E. Kellar, Edward J. Swift, and R. T. Grimshaw, all of Toronto.

Electrical Appliances, Ltd., has been incorporated at Ottawa with a capital of \$50,000, to manufacture electric stoves, heaters, and appliances of all kinds at Hamilton. The incorporators are John F. Radigan, G. G. Sutherland, and Thos. D. Fallon, all of Hamilton, Ont.

The Canadian Flexible Skate Co., has been incorporated at Toronto, with a capital of \$100,000, to manufacture a patent flexible skate at Parry Sound, Ont. The provisional directors are Carl L. Falstrom, John A. Bragg, and Henry Limbert, all of Parry Sound, Ont.

Reid Towing & Wrecking Co., has been incorporated at Ottawa, with a capital of \$200,000, to carry on the business of towing, salvaging vessels. Head office is at Montreal, and the incorporators are William K. McKeown, Leopold Choquette, and G. E. Chart, all of Montreal.

Midland Woodproducts, Ltd., has been incorporated at Toronto, with a capital of \$200,000, to operate sawmills and manufacture all kinds of wood products at Midland, Ont. The provisional directors are James Playfair, David S. Pratt and Dwight J. Turner, all of Midland, Ont.

Dominion Foundries & Steel, Ltd., has been incorporated at Ottawa, with a capital of \$6,000,000, to acquire and take over as a going concern the Dominion Steel Foundry Co., and the Hamilton Steel Wheel Co., both of Hamilton, Ont. Incorporators are, Edward H. Ambrose, Henry A. Burbidge, and John R. Marshall, all of Hamilton, Ont.

TRADE GOSSIP

The Imperial Steel & Wire Co. of Collingwood, Ont., will be reincorporated with a Dominion Charter under a new name of the Imperial Steel Corporation.

Tungsten Prices Advance.—The price of tungsten has advanced and promises to go higher owing to leading producers having advanced the ore to a new schedule operative since May 1, which fixes \$20 a unit for 60 per cent. concentrates. This represents an advance of \$3.00. The metal is now quoted at \$2 to \$2.15, New York.

St. John's, Nfld.—Inability to obtain steamers to transport their product to England has resulted in the decision of Lord Northcliffe and his assistants to shut down their large paper mills at Grand Falls. It is understood that most of the company's log choppers will take service in the forestry battalions being organized here for timber work in Great Britain.

Sarnia, Ont.—To facilitate the loading and unloading of steamers at the Point Edward freight sheds, six electrical trucks have been purchased and installed, each truck costing in the neighborhood of \$3,600. The addition of this modern equipment to the other facilities in use at the sheds, completes one of the most modern freight handling depots on the Great Lakes.

Expect Steel Record.—Conservative steel manufacturers express the opinion that earnings of the steel companies in the current month will establish a new high record. The May earnings of the United States Steel Corporation are estimated around \$45,000,000, which would be at the rate of \$540,000,000 a year, a total of about \$32,000,000 in excess of the par value of the entire common stock issue.

Steel Firm's Offer to Help Shipbuilding.—Advices from Washington state that Chairman Denman of the Shipping Board said that the steel interests had come forward with the offer to supply 400,000 tons of steel a month to aid in carrying out the Government's program. This information was received with much satisfaction by officials, in view of the situation which had been faced.

Record Price for Boiler Plate.—A report from Philadelphia, Pa., states that another high record of prices has been scored in the phenomenal eastern plate market. A sale of about 500 tons of marine boiler steel for delivery during the next five months has been made at 20 cents per pound, mill, or \$400 per ton. Shipment is to be made to a gulf point. This is the highest price for any commercial quality the eastern plate market has developed.

Vancouver, B.C.—With a capital of \$10,000,000 a new company for the manufacture of pulp and paper is to be started in British Columbia under the title of the Whalen Pulp & Paper Mills, Ltd., according to the statement made by James Whalen, who is president of the concern. Three companies have been absorbed—the B. C. Sulphite and Fibre Co. of Mill Creek, the Empire Pulp & Paper Mills of Swanson Bay, and the Colonial Lumber & Paper Mills of Quatsino, Vancouver Island.

Payment for G.T.P. Rails.—In the House of Commons at Ottawa recently, Hon. Frank Cochrane told Mr. Oliver that payments to be made to the Grand Trunk Pacific for rails taken for use in France, would be fixed under the War Measures Act, subject to adjudication by the Exchequer Court. Mr. Cochrane said that new rails would have been

cheaper than those obtained by dismantling portions of constructed roads. The military authorities, however, were unable to wait until new rails could be procured, and moreover the rail mills were not in a position to accept contracts.

Munitions Embargo Placed by Railways.—Munitions plants in Toronto are affected by the embargo ordered from the Montreal offices of the C.P.R. and G.T.R. against the acceptance of munition shipments until the congestion at ocean ports is eased and freer accommodation is provided for the transfer of shipments to ocean bottoms. This is the first time since the outbreak of the war that an embargo has been placed on munitions. Local railway officials declare that the shortage of ocean bottoms is alone responsible for the condition which has made the embargo necessary. The embargo does not affect 18-pound shrapnel, 4.5 in. howitzer shells and 4.5 in. shell forgings.

Features of Steel Demand.—Of the many varied products of the steel mills those attracting most interest at the moment are shipbuilding and railway equipment supplies. A tremendous impetus has been given to the entire trade by the heavy demand from both of these consuming industries, which has gone far in adding to quantity of unfilled tonnage at the mills. The United States Shipping Board is rapidly laying its plans for the construction of three millions of vessel tonnage within the next year and a half. This added to some two million tons now actually under construction in the various shipyards of the country swell the aggregate to the total of 5,000,000 tons.

REFRIGERATION

Montreal, Que.—The Frick Ice & Refrigeration Co. have sold a three-ton refrigerating machine to D. D. Drulard, of Windsor, Ont., and another unit to the Montreal Arena, Montreal.

Montreal, Que.—The York Manufacturing Co., York, Pa., has sold a 120-ton refrigerating machine and high side to the International Manufacturing Co., Montreal. The plant was installed by the Carrier Engineering Corp., New York.

TENDERS

Three Rivers, Que.—The City Council are receiving bids on four turbine pumps, each having a capacity of between 2½ and 3 million gallons per day.

Paris, Ont.—The Town Council are calling tenders for a centrifugal pump with a capacity of 750 gallons per minute. Full particulars may be obtained from G. H. Armsstrong, sec.-treasurer.

St. Lambert, Que.—Tenders will be received up to May 28, for the supply and installation of a horizontal shaft centrifugal pump, electric motor and switchboard. Specifications may be obtained from H. A. Gibeau, town engineer.

Sudbury, Ont.—Tenders will be received up to May 28, for the supply of



Steel Shell Forgings or Billets of any size or weight will move any distance or about curves upon our specially constructed Gravity Carriers and Incline or Horizontal power devices. No labor required.

Canadian Mathews Gravity Carrier Co., Toronto, Ont.

**Hamilton Anti-Friction
BABBITT**

A Dependable Metal for Speed and Pressure.

Geo. E. Jobborn, Hamilton, Ont.

OVENS
Enameling and Varnishing Ovens heated by Gas, Electricity, Steam or Coal. Write for Booklet.
Brantford Oven & Rack Co., Ltd.
Brantford, Canada.

"Barnes-made" SPRINGS



are the result of over sixty years' experience in spring making, combined with unsurpassed equipment and the workmanship of men who have been with us, ten, twenty and in some cases thirty years.

Write for booklet No. 7-T.

Established 1857.

THE WALLACE BARNES COMPANY
218 South St., Bristol, Ct., U.S.A.

Manfrs of "Barnes-made" Products
Springs Screw Machine Products Cold Rolled Steel and Wire

METAL STAMPINGS

We are manufacturers of stamped parts for other manufacturers.

We do any kind of sheet metal stamping that you require. Our improved presses and plating plant enable us to produce the finest quality of work in a surprisingly short time.

We can finish steel stamping in Nickel, Brass or Copper.

Send us a sample order.

W. H. BANFIELD & SONS

372 Pape Avenue, Toronto, Can.

THE IRON WORKS LIMITED

Successors to

Owen Sound Iron Works

Owen Sound, Ont.

Engineers

Boiler-makers

Founders

Machinists

Tank Work
Smoke Stacks,
Grey Iron and
Brass Castings,
Special Machinery
Made to Order

PATENT ATTORNEYS

BABCOCK & SONS

ESTAB. 1877

PATENTS-TRADE MARK-DESIGNS
 IN ALL COUNTRIES

 Book "Patent Protection"—free. Master
 of Patent Laws, Formerly Patent Office
 Examiner.

 99 St. James St., Montreal, Que.
 Branches: Ottawa, Washington.

RESEARCH BUREAU

 REPORTS BY EXPERTS ON SCIENTIFIC, TECH-
 NICAL AND INDUSTRIAL DEVELOPMENT.

SPECIAL RESEARCHES ARRANGED.

PATENTS, TRADE MARKS, ETC.

 HANBURY A. BUDDEN CABLE ADDRESS
 712 DRUMMOND BLDG., MONTREAL "BREVET"

PATENTS

Fetherstonhaugh & Co.,
 Patent Solicitors, Head Office,
 Royal Bank Bldg., Toronto,
 Ottawa Office, 5 Elgin St.
 Send for our Plain Practical
 Pointers. Copy of National
 Progress, in which our patents
 are advertised, mailed free.

PATENTS PROMPTLY SECURED

 In all countries. Ask for our Investor's Adviser,
 which will be sent free.

MARION & MARION 364 University St.

 Merchants Bank Building, corner
 St. Catherine St., MONTREAL, Phone Up. 6474
 and Washington, D.C., U.S.A.

MacKinnon, Holmes & Co.

Limited
 Sherbrooke - - Quebec

ENGINEERS, MANUFACTURERS AND ERECTORS OF STEEL STRUCTURES

Miscellaneous plate and structural
 work of every description used in
 connection with power plants fur-
 nished in short order. Engineering,
 manufacturing and erecting steel
 structures is our specialty. Write
 for prices.

all materials and erection of a 500,000-
 gallon steel stand pipe for the Town of
 Sudbury. Plans, specifications, and
 forms of tender may be obtained at the
 office of the Superintendent, R. H. Martin
 dale.

Stratford, Ont.—Tenders will be re-
 ceived up to Monday, June 11, for fur-
 nishing and constructing a radial brick
 or concrete chimney and foundations for
 the refuse incinerating plant on St.
 Patrick Street, Stratford. Specifications
 and forms of tender may be obtained
 from the office of A. B. Manson, city en-
 gineer.

Toronto, Ont.—Tenders, addressed to
 the Secretary-Treasurer of the Board of
 Education, will be received May 31, for
 lumber, white lead, turpentine, linseed
 oil, etc., required for repairs. Specifica-
 tions may be seen, and all information
 obtained at the office of the Superin-
 tendent of Buildings, Administration
 Building, 155 College Street.

Toronto, Ont.—Tenders addressed to
 the Secretary-Treasurer of the Board,
 will be received until May 30, for science
 apparatus and chemicals, garden hose,
 lawn sprinklers, garden shears, etc.
 Specifications may be seen, and all infor-
 mation obtained at the office of the
 Superintendent of Supplies, Administra-
 tion Building, 135 College street.

Toronto, Ont.—Tenders will be re-
 ceived up to June 5, for the sale and
 removal of four horizontal return tubu-
 lar boilers from the west boiler room of
 the City Hall, Toronto. Copy of terms
 and conditions may be seen, and tender
 form obtained, together with all informa-
 tion relative thereto, at the offices of the
 Property Department, City Hall.

Toronto, Ont.—Tenders, addressed to
 the chairman, Board of Control, will be
 received up to May 22 for two five-ton
 gasoline motor trucks and two three-
 and-a-half ton gasoline motor trucks
 for the Department of Street Cleaning.
 Forms of tender and conditions of tend-
 ering may be had on application at the
 office of the Street Commissioner, City
 Hall.

Brampton, Ont.—Tenders will be re-
 ceived up to June 5, for the several
 trades required in the erection of a
 school building for the Brampton High
 School Board. Plans and specifications
 may be seen at the office of the archi-
 tects and at the office of R. H. Pringle,
 Secretary of the Board, Dominion Bank
 Chambers, Brampton, Ont. Wickson &
 Gregg, Architects, Toronto.

Chatham, Ont.—Tenders for all trades
 except structural steel work, will be re-
 ceived until June for proposed 8-room

additions and alterations to Queen Mary
 School. Plans and specifications may
 be seen at Architect's office, No. 1 Vic-
 toria Block, Chatham, or at the office of
 C. E. Beeston, Secretary of the Board
 of Education, County Building, Chat-
 ham. John Methuen, architect.

Brantford, Ont.—Tenders will be re-
 ceived by the secretary of the Board of
 Water Commissioners, until May 28, for
 two electrically-driven turbine pumps
 with capacity of 300 gallons per minute
 each, also electric motors and equipment.
 Specifications, etc., may be seen at the
 office of the secretary of the Board,
 Brantford, or at the engineer's office,
 Chipman & Power, Mail Building, To-
 ronto.

Winnipeg, Man.—Tenders, addressed
 to the chairman, Board of Control, will
 be received up to May 18 for the supply
 and delivery, f.o.b. cars Winnipeg,
 freight and duty paid, to siding on
 Saskatchewan Avenue at the Decarie in-
 cinerator, of two horizontal water tube
 boilers. Plans, specifications and form
 of tender may be obtained at the office
 of the city engineer, 223 James Avenue,
 Lambert, Chambly Co., P.Q.

St. Johns, Que.—Tenders addressed to
 J. A. Raymond, secretary-treasurer of
 St. Johns, P.Q., will be received at his
 office, until May 30, for the construction
 and supplying of material in connection
 with the following works:—1—One
 water tower; 2—Pumping and mechani-
 cal gravity filtration plant. Plans and
 specifications can be seen at the office
 of Messrs. Ouimet & LeSage, 76 St.
 Gabriel Street, Montreal, engineers of
 the City of St. Johns, P.Q.

CATALOGUES

Power Machinery.—MacGovern & Co.,
 New York, have issued a list of used
 power plant and electrical machinery
 and contractors equipment, etc.

Vises and Anvils.—The Columbian
 Hardware Co. are distributing to the
 trade a catalogue dealing with the line
 of "Columbian" vises and anvils. The
 various types are illustrated and prin-
 cipal dimensions given for each size.

Cross Cut Saws.—Simonds Canada
 Saw Co., of Montreal, have issued an
 attractively illustrated catalogue of their
 Crescent groud cross-cut saws, saw
 tools and files. The pamphlet also em-
 braces illustrations of Dominion Saw
 Works Co.'s cross cut saws. Complete
 specifications and price lists are shown.
 A wide range of hand ice saws is also
 shown. Copies will be supplied on re-
 quest.

Cameron Babbitt Retainer

(Patented in Canada and the U.S.A.)

 Not like clay or other material, as it does not
 stick to the work or hands. Does away with
 using leather or paste-board at end of box.

For any metal.

 The only satisfactory compound for retaining
 molten metal and can be used over and over
 again for months—no deterioration.

For prices and samples apply to

A.S.K. Chemical Company, Elora, Ontario

CANADIAN MACHINERY

AND MANUFACTURING NEWS

A weekly newspaper devoted to the machinery and manufacturing interests.

Vol. XVII.

TORONTO, MAY 31, 1917

No. 22

EDITORIAL CONTENTS

Procuring Special Machines for Munitions Manufacture	553-555
General	555-556
Diesel Engines vs. Steam Turbines... Volcanic Steam Power... Sulphur in Steel.	
Production Methods and Devices	551-559
Turning and Threading 8-inch Adapters... Mathematics in the Tool Room...	
Roughing Profile on 18-pdr. H.E. Shell... Special Shell Machines.	
High Pressure Air Compressor Design and Application	560-564
General	564
Three Cylinder Compound Electrical Unit.	
Editorial Correspondence	565-566
Wire Ropes for Coal Mines... By-Products of Coal Distillation... Positive and Friction Clutches... Factor of Evaporation Chart.	
Progress in New Equipment	567-569
20-inch Double Back Geared Engine Lathe... Heavy Duty Milling Machine...	
Shell Nose Tightening Machine... Wire Nail Machines.	
General	569
Unusual Inventor and His Work.	
Editorial	570
Emergency and Permanent Values of Wood, and Steel Shipbuilding Industries...	
Proposed Secret Session of British Engineers.	
Industrial Notabilities	571
H. J. Waddie.	
Selected Market Quotations	572-573
The General Market Condition and Tendency	573-578
Summary... Montreal Letter... Toronto Letter... Sydney Letter... Pittsburgh Letter... Canada's Trade Balance.	
Industrial and Construction News	62-68

THE MACLEAN PUBLISHING COMPANY, LIMITED

JOHN BAYNE MACLEAN, Pres. H. T. HUNTER, Vice-pres. H. V. TYRRELL, Gen. Man.

Publishers of Hardware and Metal, The Financial Post, MacLean's Magazine, Farmer's Magazine, Canadian Grocer, Dry Goods Review, Men's Wear Review, Printer and Publisher, Bookseller and Stationer, Canadian Machinery and Manufacturing News, The Power House, The Sanitary Engineer, Canadian Foundryman, Marine Marine Engineering of Canada.

Cable Address: Macpubco, Toronto; Atabek, London, Eng.

ESTABLISHED 1887

CANADIAN MACHINERY AND MANUFACTURING NEWS

PETER BAIN, M.E., Editor. B. G. NEWTON, Manager.
Associate Editors: A. G. WEBSTER, J. M. WILSON, J. H. RODGERS.

CHIEF OFFICES:

CANADA Montreal, Southam Building, 128 Bleury Street, Telephone 1904; Toronto, 143-153 University Ave. Telephone Main 7324; Winnipeg, 22 Royal Bank Building, Telephone Garry 2313.
GREAT BRITAIN LONDON, The MacLean Company of Great Britain, Limited, 88 Fleet Street, E.C., E. J. Dodd, Director. Telephone Central 12960. Cable Address: Atabek, London, England.
UNITED STATES New York, R. R. Huettis, Room 629, 111 Broadway, N.Y., Telephone Rector 8971; Boston, C. I. Morton, Room 733, Old South Building, Telephone Main 1291. A. H. Byrne, 1104-5-6-7 Fort Dearborn Bldg., 105 W. Monroe St., Chicago, Telephone Randolph 3239.
SUBSCRIPTION PRICE Canada, Great Britain, South Africa and the West Indies, \$3.00 a year. United States, \$3.50 a year; other countries, \$4.00 a year; Single Copies, 15 cents. Invariably in advance.

If there is one machine more than another where

Absolute Accuracy

is required, it is in the construction of an Experimental Lathe.

Accurate fitting, assembling, aligning of head and tailstock and carriage with lathe bed, is found without exception in the "Hendey."

Motor-driven. Besides regular equipment it has small tool cabinet for operators' fine tools—also gear closet for extra gears to cut special threads.

Let us tell you more about it.

The Hendey Machine Co.

Torrington, Conn., U.S.A.

Canadian Agents: A. R. Williams Machinery Co., Toronto, Ont.; A. R. Williams Machinery Co., 260 Princess St., Winnipeg; A. R. Williams Machinery Co., Vancouver; A. R. Williams Machinery Co., St. John, N.B.; Williams & Wilson, Montreal.



Hendey Experimental Lathe

12. Inch

INDEX TO ADVERTISERS

Adams, Ogden R. 102	Davis, W. F., Machine Tool Co. 77	Keystone Mfg. Co. 84	Rivet Lathe & Grinder Co. 118
Anchorhead Hardware Co. 63	Delano Smelting & Refining Co. 11	Kemp-Smith Mfg. Co. 25	Rockford Drilling Mach. Co. 159
Armstrong Bros. Tool Co. 105	Delta File Works 64	L	Rockwell Co., W. S. 100
Armstrong, Whitworth of Canada. 14	De Mooy Mach. Co. 111	L'An Liquid Society 29	Roelofson Machine & Tool Co. 13
A. S. K. Chemical Co. 65	Dickroy, Fred. C. 67	Landis Machine Co. 7	Roper & Co., C. F. 82
Atkins, Wm., & Co., Ltd. 15	Dominion Belting Co., Ltd. 68	Latrobe Electric Steel Co. 20	S
Aurora Tool Works 109	Dominion Bridge Co. 88	London Bolt & Hinge Co. 67	Scott, F. H. 102
B	Dominion Iron & Wrecking Co. 26	Lynde Fatigue Co. 73	Sheddons, Ltd. 92
Babcock & Sons 98	Dominion Machinery Co. 29	M	Shuster Co., F. B. 98
Baird Machine Co. 101	Dominion Steel Foundry Co. 98	MacNab Machy. Co., The John. 17	Shore Instrument & Mfg. Co. 99
Banfield, E. J. 16	E	Magnolia Metal Co. 88	Silver Mfg. Co. 109
Banfield, W. H., & Sons 68	Eastern Machine Screw Corp. 95	Manufacturers Equipment Co. 94	Simmons Mach. Co. 69
Barnes, W. F. & John 109	Elmes, Chas. F. 90	March & Heathorn, Ltd. 30	Skinner Chuck Co. 23
Barnes, Wallace, Co. 66	Eric Foundry Co. 28	Matthews, Jas. H., & Co., Inc. 33	Sleeper & Hartley Co., Inc. 69
Bath, Cyril J. 75	F	McAbee, J. J. 23	Smooth-On Mfg. Co. 111
Baxter & Co., Ltd., J. R. 15	Fetherstonhaugh & Co. 68	Mc'oy-Brandt Machy. Co. 74	Smart-Turner Mach. Co., Ltd. 85
Beatty & Sons, M. 75	Fitzgerald, W. H. J. 74	McGougall Co., H. Inside back cover	Standard Aloys Co. 9
Bennett, W. P. 69	Fleck, Alexander, Limited 87	McKenzie, The D. K., Machy. Co. 21	Starrett Co., L. S. 27
Beams & Call Hardware & Tool Co. 85	Ford Chain Block & Mfg. Co. 66	McLaren, J. C., Belting Co. 98	Steele, Ltd., James 67
Berram, John, & Sons Co., Ltd. 1	Foss & Hill Machy Co. 81	Mechanical Engineering Co. 115	Steteler Co., Chas. 17
B	Francis & Co. Inside back cover	Metal Mfg. Service 79	Steel Co. of Canada 3
Bertram's, Limited 67	G	Metalwood Mfg. Co. 91	St. John, Co. 83
Bellon Machine Tool Co. 28	Galt Mach. Screw Co. 101	Michigan Steel Exchange, Inc. 12	Struk & Sons, John 67
Bloss, E. W., Co. 91	Gardner Machine Co. 101	Monarch Brass Mfg. Co. 84	Stocker-Rumley Warbs Co. 77
Bradford Oven & Rack Co. 65	Gardner, Robt., & Sons 79	Montgomery Smith & Co. 89	Stow Mfg. Co. 20
Bridgford Mach. Tool Works 5	Gardner-Walker Machy. Co. 75	Montreal Machy. & Supplies 107	Sveedish Steel & Importing Co. 14
Bristol Company 98	Gavin Machine Co. 18	Morse Chain Co. 83	Sveedish Gage Co., Inc. 81
Brownell Machy. Co. 73	Geometric Tool Co. 61	Mouton Mfg. Co. 68	T
Brown's Copper & Brass Rolling Mills 93	Gilbs Instrument Co. 117	Muir, Wm., & Co. 67	Tabor Mfg. Co. 191
Brown & Sharpe Mfg. Co. 105	Gilbert & Barker Mfg. Co. 112	Munchev Machine & Tool Co. 96	Tallman Brass & Metal Co. 78
Budon, Hambury A. 68	Gooley & Edmund, Inc. 28	N	Tate-Jones & Co. 105
Butterfield & Co. 97	Grant Gear Works, Inc. 100	Napier Saw Works 106	Taylor Instrument Co. 115
C	Grant Mfg. & Machine Co. 113	National Machinery Co. 102	Thwing Instrument Co. 91
Canada Machinery Corporation. Outside back cover	Greenfield Machine Co. 99	National Machine Tool Co. 101	Tobelo Machine & Tool Co. 91
Canada Metal Co., Ltd. 88	H	New York Machinery Exchange 76	Toronto Iron Works 98
Canada Sales Co. 82	Hall & Sons, J. H. 91	Nicholson File Co. 99	Toronto Welding Co. 85
Canada Wire & Iron Goods Co. 82	Hamilton Gear & Machine Co. 78	Noble & Westbrook Mfg. Co. 99	Trabren Pump Co. 87
Can. B. K. Manton Co. 6	Hamilton Machine Tool Works. 19	Niles-Bement-Pond, Inside front cover	Transcona Shell Co. 74
Can. Fairbanks-Morse Co. 34	Hanna & Co., M. A. 14	Northern Crane Works 98	C
Can. Billings & Spencer 82	Harding Bros. 24	Norton, A. O. 100	Union Dravn Steel Co. 93
Can. Bridge Co., Ltd. 75	Harlock-Walker Machy. Co. 75	Norton Co. 32	United States Elect. Tool Co. 53
Can. Desmond-Sterdian Mfg. Co. 82	Hawkey Machine Co. 120	Nova Scotia Steel & Coal Co. 10	Union Tool Chest Works 101
Can. Dravn Steel Co. 99	Heplum, John T. 5	O	V
Can. Economic Lubricant Co. 87	Hem-off Mach. Co. 18	Oven Equipment & Mfg. Co. 113	Vanadium Alloys Steel Co. 15
Can. Inspection & Testing Laboratories, Ltd. 98	Homer & Wilson 89	Osborn (Canada) Ltd., Samuel. 107	Victoria Fly Co. 27
Can. Metal Products 80	Hoyle Metal Co. 102	P	Victor Tool Co. 15
Can. Steel Foundries, Ltd. 7	Hunter Saw & Machine Co. 22	Parmenter & Bulloch Co. 100	Vulcan Crucible Steel Co. 15
Can. S. K. F. Co., Ltd. 4	Hungarford Brass & Copper Co. 92	Perrin, Wm. H. 91	W
Can. Welding Works, Ltd. 113	Hurbit-Rogers Machinery Co. 25	Pierless Machine Co. 23	Walton Co. 95
Carlyle Johnson Mach. Co. 8	Hvle Engineering Works 25	Petrie, H. W., Ltd. 71	Wells Bros. Co. of Canada 32
Cataract Refining Co. 84	I	Petrie of Montreal, Ltd., H. W. 71	West Tire Setter Co. 99
Chapman Double Ball Bearing Co. 86	Ideal Tool & Mfg. Co. 96	Philadelphie Gear Works 79	Wilkinson & Kompass 102
Chesterman, Jas., & Co., Ltd. 102	Independent Pneumatic Tool Co. 31	Plessisville Foundry 66	Whiting Foundry Equipment Co. 87
Chicoutimi Pulley Machy. Co. 111	Ion Works, The 66	Port Hope File Mfg. Co. 31	Whiting Mach. Co., D. E. 101
Cleveland Wire Spring Co. 67	J	Positive Clutch & Pulley Works. 89	Williams, A. R., Machinery Co. 7
Cook, Asa S. 100	Jacobs Mfg. Co. 94	Pratt & Whitney. Inside front cover	Williams, J. H., & Co. 85
Corbet Foundry & Mach. Co. 16	Jancke Mach. Co. 9	Pringle, R. E. T., Ltd. 71	Willson & Co., T. A. 109
Cullen Machy. Co., C. W. 74	Johnson, Geo. E. 8	Pritchard-Andrews Co., of Ottawa. 21	Williams Tool Co. 24
Curtis & Curtis Co. 22	Johnson Mach. Co., Carlyle 8	Puro Sanitary Drink'g Fountain Co. 65	Windsor Mach. & Tool Works 83
Cushman Chuck Co. 101	Love Co., Geo. A. 109	R	Winnipeg Gear & Engineering Co. 79
Davis-Bourneville Co. 99	Jones & Glasco 100	Rache Tool & Machine Co. 23	Worth Engineering Co. 68
	K	Richmond Mfg. Co. 95	Z
	K. I. & GooJwin 67	Riverside Machy. Dept. 71	Zenith Coal & Steel Products Co. 99

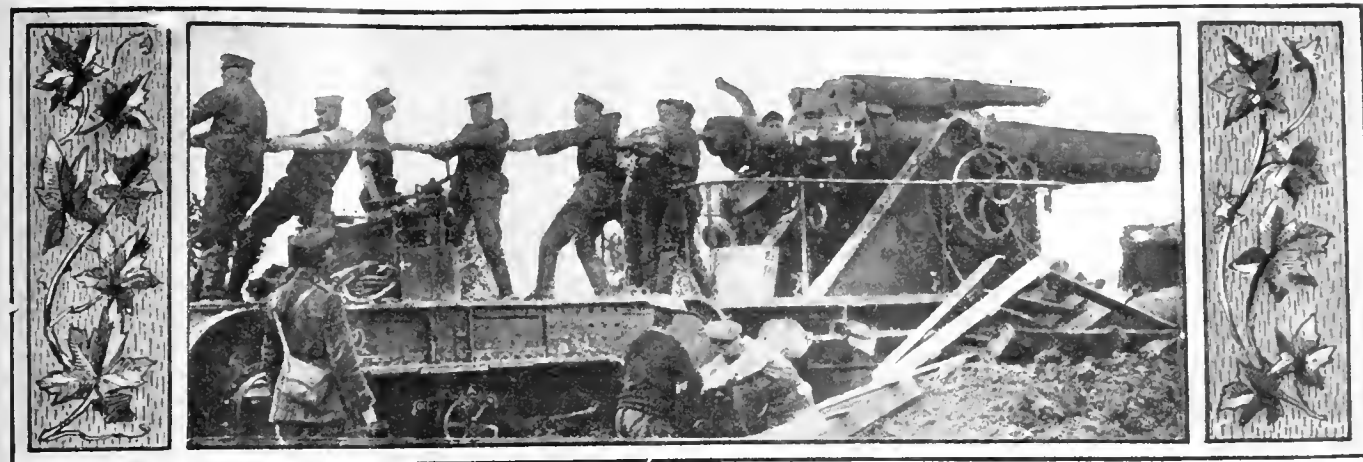

PREPARING A LARGE SIEGE GUN FOR ANOTHER ROUND ON THE WESTERN FRONT.

Procuring Special Machines for Munitions Manufacture*

By H. V. Haight

The subject matter of the accompanying paper relates to the machining and assembling of British 18-pdr. shrapnel, and 8-inch Howitzer shell, each of which is discussed separately. In addition to what may be termed his local experience, the writer has visited numerous shell shops both in Canada and the United States; he is, therefore, in a position to express a worthwhile opinion as to machines required, and indicate whether they should be bought or made.

AS NO two manufacturers of munitions follow the same methods or use the same machines, any opinions the writer may advance must be based on his own experience or observation and will be subject to confirmation or modification when compared with the experience of others. The writer's firm is engaged in machining and assembling the British 18-pdr. shrapnel and the British 8-inch howitzer shell. Under the plan of organization of the Canadian Imperial Munitions Board, the work is all sublet by the latter. The contractor for machining and assembling shrapnel, for example, is furnished with forgings for the bodies, also with finished component parts such as discs, sockets, copper bands, tubes, tin cups, bullets, etc., and with the other materials required, such as resin, solder, paint and shipping boxes

18-Pdr. Shrapnel

When undertaking the first contract for shrapnel, our firm had a machine shop which could be converted to its production, also an experienced working force. As output increased, and as the regular work picked up, additional machines were purchased or made, until all the regular tools had been withdrawn from shrapnel service. In many cases these regular machines were withdrawn because required for making our regular product; however, there was the additional reason that for four-fifths of the operations the new tools purchased or made were more productive than the regular tools used at first. Our experience, therefore, has covered the use of standard machine tools, special pur-

chased machines, and special machines made by ourselves.

Fig 1 shows the shell at several stages, and the numbers indicate the operations described below.

Cut off open end.—Standard 4-inch cutting-off machines with air expanding mandrils. Production 900 in 8 hours. We also tried a special machine to cut off both ends at one setting and another machine

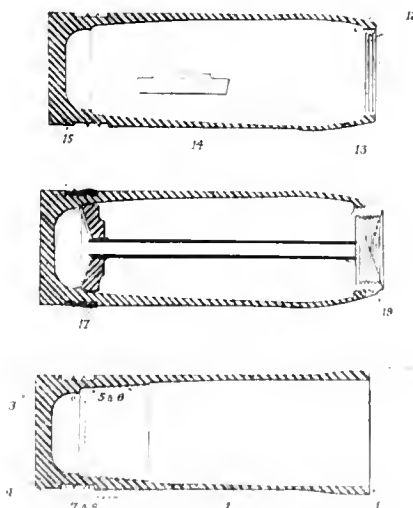

FIG 1 INDEX OF OPERATIONS IN MACHINING SHRAPNEL.

of the type of a pipe-threading machine, but both proved failures and were returned to the makers. On the regular machines the air mandril is preferred to the universal chuck as it is much quicker and costs less to keep in repair.

Rough-turn body.—We used at first heavy 24-in. engine lathes, 21-in. Gisholts, Loswing lathes, etc., with fair re-

sults but we are now using single-purpose lathes of our own make which produce more work and are much simpler to keep in repair. These lathes have cast-iron spindles, 6½ in. in diameter in the front bearing, with driving gear integral with the spindle. They have tight and loose pulleys on the back-gear shaft, thus eliminating countershafts with their troubles. The feed is by belt, eliminating feed-gear troubles. The work is chucked on an air expanding mandril and turned with a bar cam to give the necessary enlargement at the open end of the shell for the subsequent bottling.

Rough-face base.—We have used 36-in. engine lathes, 42-in. and 60-in. vertical boring mills, 36-in. planers, 30-in. planer-type millers, etc., on this work, but have abandoned them all for 4-in. standard cutting-off machines. On milling machines the tool upkeep is too great, on planers the work is hard to hold, on planers and boring mills the intermittent cut is hard on the machines, and on all except the cutting-off machines the labor cost and upkeep are too high. On the cutting-off machines the regular universal chuck is omitted and a plain hinged chuck used, as a universal chuck will not stand shell work. The regular cutting-off tool blocks are replaced with a tool block to hold a facing tool. When the countershaft clutch pulleys give out, they are replaced with tight and loose pulleys. Each man runs two of these machines.

Finish-face and turn base. Standard 16-in. lathes, with air collet chucks supported by steady rests, give satisfactory service on this operation. Only hand feeds are used.

Rough and finish bore. It has been found best to rough bore on one machine

*Paper presented at the Spring Meeting, Cincinnati, Ohio, May, 1917, of the American Society of Mechanical Engineers.

**Plant Chief Engineer, Sherbrooke, Que.

and finish on another. Turrets are not desirable on shell work, where they can be easily avoided. We used a well-known make of turret lathes on this work, but they proved pretty light and required considerable repair. They were eventually withdrawn for regular work and replaced by special boring lathes of our own make, in which the work is held inside the spindle by an air collet chuck. Two different feed mechanisms are in successful use, one on a central rack with power feed and air return, the other a crank and "Scotch Yoke" with hand feed. Another Canadian munitions plant made very successful boring machines from gasoline-engine patterns. We built a double-spindle lathe for this work but it proved a failure.

Rough band groove.—This work is being done on cutting-off machines and also on lathes of our own make. In both cases the work is held in push-out air collet chucks. No longitudinal feed is required and only a hand cross-feed.

Finish band groove.—This consists of undercutting the edges and forming the waved ribs. Potter & Johnston automatics are in successful use and stand up well. It has been found, however, that a man can do more work on one machine than he can on two or three, so the automatic feature is of no use on this work. Regular 20-in. engine lathes with the special fixtures, and simple lathes of our own make with similar special fixtures, are now preferred as they produce rather more work. This is the only operation on which universal chucks are still used, but they will probably be superseded by air chucks. Two different purchased waving machines, built for this purpose alone, were tried but proved unsuccessful.

Harden.—We used at first muffle furnaces, with cast-iron pot muffles holding eight shells, but now we use large semi-muffle furnaces holding 50 shells. The furnaces are built to design furnished us by another shell manufacturer, but appear to be copied from a commercial furnace. We used pyrometers at first, but now the operators go by the color. An "Irite" pyrometer is used to train new men.

Bottle.—The noses of the shells used to be heated by dipping in a pot of lead. This was rather expensive in the use of lead, and also gave a little trouble from lead poisoning. The present method is to heat in an oil furnace having holes through which the shells project into the furnace. A water-jacketed front was tried, but fire-brick with iron thimbles has been found better. We built these furnaces after the style used in another shell shop. The bottling presses used at first were air presses which we made ourselves from drill sharpeners, but the present practice is to use geared crank presses which are purchased. After bottling, the shell is put back in a similar furnace to anneal the nose.

Shot blast.—The regular foundry sand blast was used at first, but present practice is to use a small shot-blast machine of our own make. This has two jets, one of which cleans the band groove and the other the base. The shot-blast gives

practically no dust, and can be used anywhere in the shop.

Turn and thread nose.—This requires a fairly heavy turret lathe, and we are using both 24-in. engine lathes and also single-purpose lathes of our own make, both of which are equipped with turrets. We prefer the latter lathe as they take the work inside the spindle and eliminate the steady rest. Air collet chucks are used. This is the only operation on the shrapnel where a turret is used and this requires five holes of the turret.

Grind nose and grind body.—Standard grinders, slightly modified for the wide wheels used on shell work, give satisfactory results, as do also special purchased shell grinders. The grinding machine manufacturers, of all the regular machine-tool builders, come out with the greatest credit from the viewpoint of shell production. In most other cases the shell manufacturers themselves have built more suitable machines than either standard or special machines built by the machine-tool manufacturers.

Grind base.—Simple machines of our own make give good results.

Press copper band.—Two different hydraulic band presses, both designed and

though the use of air chucks will largely eliminate countershaft troubles, as it is not necessary to stop to change work. It is better, however, to have tight and loose pulleys on the headstock and eliminate the countershafts, as they take up so much room overhead that it is difficult to group the machines to best advantage. The elimination of countershafts also reduces the cost of belting, which is quite an item.

A special point for consideration is the depth of dovetail on the carriage, for the cross-slide. This should be $1\frac{1}{2}$ in. to $1\frac{1}{4}$ in. deep, but there are at least two of these lathes on the market with dovetail $\frac{3}{8}$ in. to $\frac{1}{2}$ in. deep, and a taper gib. The very small surface is not sufficient to resist the side strain of a cam, which is used on two of the operations, and the height is not sufficient to use a straight gib with set screws. It is usually necessary to replace the regular cross-slide with a special cross-slide, and when doing so it is much simpler to use a straight gib with set screws, rather than a taper gib.

Shrapnel Summary

To sum up, a manufacturer starting to make shrapnel would be well advised to consider the following suggestions:

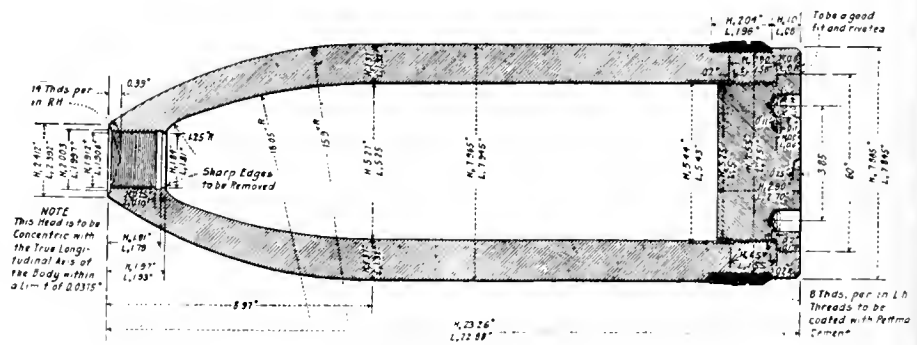

FIG. 2. BRITISH 8-INCH HOWITZER SHELL.

built by other shell manufacturers, are giving good results on this work.

Turn band.—A heavy engine lathe with special equipment and an air collet chuck gives good results, but costs more money than a very good special band-turning lathe, built by another shell manufacturer.

Fill.—This is nearly all home-made equipment and hardly requires detailed description here.

Turn socket.—A 16-in. engine lathe is heavy enough for this. A clutch on the back gear is convenient. A turret is not desirable.

Paint.—We use with satisfaction a small portable machine of our own make, driven by a 1/6-h.p. motor.

Single-Purpose Lathe Features

The foregoing does not cover the use of purchased single-purpose lathes, of which there are now a large number of designs on the market, but from experience with three or four types of these on 8-in. shells, it appears that they should give good results on shrapnel work. The features they should have would be a large spindle, 4 in. to 5 in. diameter, with the hole at least $1\frac{15}{16}$ in., strong drive and feed, a good feed-engaging clutch, or better still a drop worm. The counter shaft should have tight and loose pulleys,

Perform simple operations and use simple machines. Do not try to perform several operations at one setting, and do not buy automatics, turret lathes or other complicated machines.

A pretty safe and satisfactory plan is to get a quick start at some fraction of full intended capacity, and to add equipment and build up production after some experience has been gained.

Suitable purchased machines for making a quick start would be regular cutting-off machines, regular engine lathes 16-in. to 24-in. swing, simple single-purpose lathes, regular or special grinders and such special machines as bottling presses, band presses and band lathes.

It will be worth while to consider the organization of a lathe-building department to supply many of the machines required to increase the capacity. This department might also undertake the making of air chucks, waving devices and other special attachments, and thus relieve the tool room. Later, this department would become a repair department, which is an important and busy department when work is being pushed day and night.

8-inch Howitzer Shell

The British 8-in. howitzer shell (Fig.

2) is forged with the base open. After finishing the shell, the base is closed with a screwed base plug called an adapter. When we undertook a contract for these shells, we decided to make most of the lathes and other equipment ourselves, and for that purpose organized a lathe-building department. These lathes gave very satisfactory results as to first cost, upkeep, and rate of production. They take up much less floor space than the standard or special-purpose lathes which we were offered, and enable the machines to be grouped so that the work can be handled very cheaply. The longest beds of these lathes are 8 ft. 6 in., and many of them are 7 ft. and 6 ft. 6 in. long. The absence of countershafts is also a feature which enables the lathes to be closely grouped. The lineshafts run crosswise of the shop, while the work also progresses across the shop from operation to operation. Long tables for holding the work run lengthwise of the shop between the ends of the lathes. The operator takes a shell from one table and, after completing the operation on it, places it on the next table, thus avoiding trucking.

Experience on this shell has confirmed the principle of doing simple operations on simple machines. For example, at first we undertook to rough-bore, ream and counterbore at one setting, but soon found it was better to make three separate operations on three different machines. The only operations which are done at the one setting are those which it is essential to have concentric. Thread milling had been superseded by tapping. We know of other manufacturers who have tried to make this same shell by doing a large number of operations at one setting, and have made special machines for that purpose. They have, however, since discarded this plan and have come around to the general principle of doing one operation at a setting.

While the special-purpose lathes which we have built for this work have proven very satisfactory and have a number of advantages over purchased machinery, yet it took some time to get them designed and built. As in the case of shrapnel, the manufacturer would be wise to purchase a portion of the machines necessary to get a quick start at some fraction of the desired ultimate capacity.

DIESEL ENGINES v. STEAM TURBINES

A COMPARISON of the cost of generating power by means of Diesel engines and steam turbines, together with a discussion of the different factors governing the profitable use of either type, is given in a paper read by Herbert Haas at the Arizona meeting of the American Institute of Mining Engineers. The author says that in places where neither cheap coal nor water power is available, and the price of oil fuel is increased by cost of carriage, the Diesel engine will become a prime mover of increasing importance. Where water is scarce the Diesel engine also shows to advantage,

because about twelve times as much water will be required for condensing purposes with steam turbines under general conditions as is needed for jacket cooling of the two-stroke engine, while engines of the four-stroke pattern require only one-twentieth of the water. The following table of costs of generating power with four 2,000-kilowatt Sulzer-Diesel engines, direct-connected with alternators and exciters, is based on a fuel cost of \$1.25 per barrel of 320 lb., and lubricating oil cost of 35 cents per gallon:—

TABLE I.—COST OF GENERATING POWER WITH FOUR 2,000-KILOWATT SULZER-DIESEL ENGINES DIRECT CONNECTED TO GENERATORS AND EXCITERS.

	Full load 12,000 h.p. 8,000 kw. 70,000,000 140,000	¾ load 9,000 h.p. 6,000 kw. 52,500,000 105,000	½ load 6,000 h.p. 4,000 kw. 35,000,000 70,000	¼ load 3,000 h.p. 2,000 kw. 17,500,000 35,000
Kw. hr. per year	70,000,000	52,500,000	35,000,000	17,500,000
Barrels	140,000	105,000	70,000	35,000
	Cost per year	Cost per year	Cost per year	Cost per year
Fuel cost	£35,000	£26,200	£17,500	£ 8,750
Labor	3,780	3,780	3,780	3,780
Lubrication	6,130	4,599	3,066	1,533
Maintenance	1,440	1,440	1,440	1,440
Total direct	146,350	£36,019	£25,786	£15,503
Interest and amortisation	17,280	17,280	17,280	17,280
Total cost	£63,630	£53,299	£43,066	£33,783
Cost per kw. year	7.9	6.6	5.4	4.2

The kilowatt-year is equivalent to 8,760 kilowatt hours. Three units work continuously, and one acts as a stand-by and the cooling water in circulation for 9,000 horse-power, working continuously, amounts to 8,000 to 11,000 cubic feet per hour with re-cooling arrangements.

In table II. the costs of operation under similar conditions, with power generated by two 6,000-kilowatt turbines, are shown. The turbines work with steam at 180 lb. pressure per square inch, steam temperature 620 deg. Fah., inlet temperature of condensing water 60 deg. discharge temperature 75 deg. Fah., quantity of cooling water per 6,000 kilowatt-unit, 74,000 cubic feet per hour. One generating set works continuously at full load and the other is a stand-by:—

TABLE II.—COST OF GENERATING POWER WITH TWO 6,000-KILOWATT STEAM TURBINES.

	Full load 8,000 kw. 70,000,000 300,000	¾ load 6,000 kw. 52,500,000 210,000	½ load 4,000 kw. 35,000,000 150,000	¼ load 2,000 kw. 17,500,000 87,700
Kw. hr. per year	70,000,000	52,500,000	35,000,000	17,500,000
Barrels	300,000	210,000	150,000	87,700
	Cost per year per kw. hr.	Cost per year per kw. hr.	Cost per year per kw. hr.	Cost per year per kw. hr.
Fuel cost	£75,000	£52,300	£37,400	£20,925
Labor, etc.	5,000	5,000	5,000	5,000
Maintenance	1,440	1,440	1,440	1,440
Total direct	£81,440	£58,840	£43,840	£27,365
Interest and amortisation	17,280	17,280	17,280	17,280
Total cost	£98,720	£76,120	£61,120	£44,645
Cost per kw. year	12.2	12.6	15.2	22.3

The selection of two 6,000-kilowatt rather than three 3,000-kilowatt steam turbines is made on account of the greater efficiency of the 6,000-kilowatt sets, while the selection of four 2,000-kilowatt Diesel engine units is justified by the author on the ground that larger engines are not any more efficient in fuel economy, and the relative much higher cost of this prime mover makes it a good policy to reduce reserve capacity to a safe minimum.

Prime Mover Selection Considerations

The author concludes that in general the selection of either type of prime mover will be governed by the following economic considerations:—

1—Fuel is of chief influence on the total power cost, where both the B.t.u. price and load factor are high. These conditions favor the use of the Diesel engine.

2—Interest and redemption (amortisation) are of chief influence on the total power cost with low B.t.u. price and low load factor. This applies particularly to

stand-by plants, which are operated only occasionally or have to supply recurring peak loads. The installation cost of such plants must be kept as low as possible so as to avoid heavy capital charges distributable over a relatively small kilowatt-hours output of the station. Such conditions favor the steam turbine.

3—Exceptions to (2) are cases where the constant and instant readiness of the Diesel engine give it preference, and installation cost is of secondary importance. Here it is necessary to balance the cost of keeping boilers under steam continuously against the difference of interest charges of steam turbine and Diesel engine plants.

4—For power plants erected at the source of the fuel, either in the oilfields,

or at the coal mine, prime movers will be selected, costing least to instal, i.e., steam turbines, since fuel expenditures will weigh less than interest and redemption charges.

5—In many cases combination plants using Diesel engines for supplying the continuous and nearly constant main load, and steam turbines for furnishing periodically occurring peaks by the use of high-duty boilers with large water and steam spaces, capable of being forced

when necessary, will prove most profitable.

6—Steam power will remain the cheapest power wherever waste-heat gases are available, as, for instance, gases from reverberatory smelting furnaces, where nearly one-half of the fuel used in smelting can be utilized for steam generation. Nearly 3,000,000 B.t.u. for every ton of charge smelted are thus available for steam generation, or about 150 horse power hour per ton of charge.

7—Up to capacities of 1,000 horse-power steam turbines can compete with Diesel engines only in special cases, such as supplying exhaust steam for heating purposes. For such small units, particularly for greatly varying loads, reciprocating steam engines are preferable. For larger plants, from 1,000 to 10,000 kilowatt capacity, careful analysis must be made of the relative advantages of Diesel engines and turbines, a knowledge of the load factor, fuel prices, and water conditions being necessary. For power plants larger than 10,000 than 10,000 kilowatts, using units from 6,000 kilowatts upward, steam turbines have the preference, unless a combination of high load factor, high fuel cost, and poor water conditions favor a Diesel plant.



VOLCANIC STEAM POWER

By D. Street.

THE harnessing of volcanic heat to industrial purposes is an idea that has often presented itself to the visionary mind, but it needed the war to bring the project into the realm of commercial actuality. The price of coal in the inland towns of Italy has now reached the fantastic level of \$50 a ton, and, in consequence, attention has been turned towards other possible sources of power.

In Central Tuscany, as is well known, there are numerous cracks in the ground from which jets of steam spout high in the air with great force and constancy. As far back as 1903, tentative experiments were made with a view to using this steam for the generation of power. Holes were bored in the ground down to the source of the steam, which is a hard stratum of rock about 300 to 500 feet below the surface. These bore-holes which are lined with iron pipes and vary from 15 to 20 inches in diameter, were found to yield steam with a pressure of 2 to 3 and exceptionally up to 5 atmospheres, at temperatures varying from 150 to 190 deg. C. For several years these jets have not been diminished in their capacity nor does a new boring seem to interfere with the preceding ones, provided the distance from one to another is not less than 50 feet.

Method of Application

In a recent communication, Prof. Luiggi has given an account of steps that are being taken to use this steam on a large scale. Prince Ginori-Conti, to whom the earlier experiments were due, acting on the advice of the Tosi Works, of Legano—specialists in steam turbines and alternating electric generators—or-

dered three groups of condensing turbo-electric engines, each of 3,000 k.w., working with superheated steam at 1½ atmospheres, to be worked by the head of the volcanic steam jets. The steam is not used direct in the turbines, on account of the corrosive elements, which it contains, but fed to specially constructed multi-tubular boilers which, in turn, give off the steam used in the turbines. In the boiler the volcanic steam gives up about 60 deg. C. of its heat, the temperature falling from 180 to 120 deg. C. The steam generated in the boilers and used for the turbines is thus ordinary water steam, which, on its way to the turbine passes along aluminum pipes heated outside by a current of superheated natural steam, at 180 deg. C.

After passing through the turbine that steam is discharged into a surface condenser, the circulating water of which is in its turn cooled in an ordinary cooling tower. The condensed steam from the turbines is, of course, pumped back into the boilers and thus no natural steam ever come in contact with the turbines; by this arrangement corrosion is completely avoided. Professor Luiggi states that one of the 3,000 k.w. units has been at work since January, 1916, the second since April, and the third has just been started.

So far, the first two groups have worked quite successfully, and have been a great boon to the industries of Tuscany, greatly crippled by the scarcity and high price of coal. The very successful harnessing of volcanic heat to an electric power house can be increased practically to hundreds of thousands of horse-power, as the region of the steam-jet extends for many square miles.



SULPHUR IN STEEL

By L. E.

THE long established belief that the effect of sulphur in steel is to make it unreliable has frequently been questioned in recent years. It has come to be generally recognized that high sulphur in pig-iron is caused by poor furnace conditions, and that the sulphur is merely one indication of an iron that has not been properly produced. When this is the case, no amount of subsequent treatment under oxidising conditions in the open-hearth furnace can remedy the trouble, although the percentage of sulphur may be considerably reduced. The effects are carried forward into the finished steel, and there are good reasons for supposing that here also high sulphur is not so much the cause of unreliability as a symptom, and it might very well follow that a high sulphur is not harmful, provided the steel is not otherwise poor, due to insufficient reduction in the blast furnace. The question is receiving attention in many quarters.

In a recent American investigation tests have been carried out upon three steels having sulphur contents of 0.04, 0.09 and 0.16 per cent., the other elements remaining for all practical pur-

poses the same. All the specimens were heated just above the critical range, quenched in water, and various sets of specimens were reheated to different temperatures ranging from 300 to 600 deg. C., and again cooled in various ways. After heat treatment the specimens were tested for tensile strength and for resistance to repeated shock,—the Charpy pendulum machine being used for the latter test. This machine consists of a heavy pendulum, which drops from a fixed height and strikes the specimen which is supported from each end, and breaks it at notch. The pendulum then continues its swing and the height it reaches is registered. Knowing the weight of the pendulum, the height it falls, and the height it rises, a simple calculation gives the energy consumed in breaking the specimens.

The results of the tensile tests showed that sulphur does not lower the tensile strength. The figures obtained for elongation and reduction of area show that there was little difference in ductility between the low and medium sulphur steels, but the ductility of the high sulphur steels was slightly lower than the other two for most of the treatment. The average figures for the shock tests, except for the air and furnace cooled specimens, were highest for each treatment in the case of the low sulphur steels and lowest for each treatment of the high-sulphur steels. The widest difference appeared in steels which were quenched and reheated.

It is difficult to draw definite conclusions from the results, because of the newness of the shock tests and the difference of opinion among engineers regarding its value. The tensile tests were not favorable to steels with a moderate percentage of sulphur, while the shock tests showed a decided falling off in strength as the sulphur increases. Until the interpretation of the results from the Charpy machine is more fully understood, it is impossible to say to which set of tests the most importance should be attached. It is important that the question of sulphur in steel should be settled, not only because the elimination of sulphur entails much trouble and expense, but also because a moderate percentage of sulphur is an aid to machining. The low sulphur material drags, and the production of a smooth surface is very difficult. A slight increase in sulphur enables the machinist to produce a smooth surface without difficulty.



“An Irish hostess, when she asks if you'll have sugar in your 'tay,' holds out the bowl and absent-mindedly goes on with her conversation, allowing you to help yourself.

“An English hostess asks, “One lump or two?” and carefully drops the sugar into your tea.

“If you should ask a Scotch hostess for a little more sugar in your tea, she would demand, with a note of surprise, ‘And hae ye stirred it yet?’”

PRODUCTION METHODS AND DEVICES

A Department for the Interchange and Distribution of Shop and Office Data and Ideas Evolved from Actual Practical Application and Experience

TURNING AND THREADING 8-IN. ADAPTERS

By R. Hamilton.

WHERE parts having two or more diameters require to be fitted together, as is the case on the adapters of the large shells, it is particularly desirable that the threading process should be performed at the same setting of the shell as that of turning the several diameters in order to avoid as far as possible any tendency to eccentricity that would prevent the accurate fitting of the parts. Where these operations are accomplished on different machines or at different settings of the shell, it is almost impossible to have the threaded portion concentric with the other two diameters—those of the pilot and the base portion. In addition to obtaining the highest degree of accuracy in machining of the parts, it is an important factor in connection with maximum production that the facilities for achieving this purpose be so designed that rapidity and economy are only secondary to accurate product. The illustrations herewith show the design of a fixture developed and used by the Ingersoll-Rand Co., of Sherbrooke, and placed on one of their special machines for the

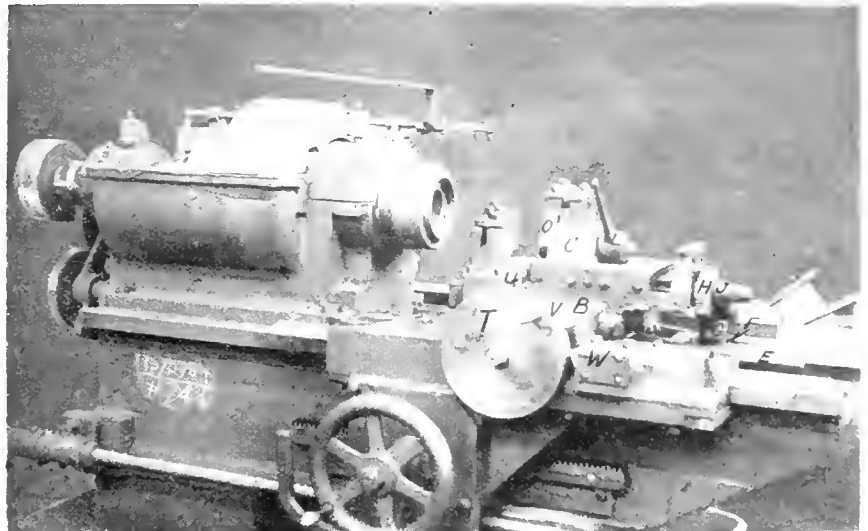

TURNING AND THREADING 8" ADAPTERS

of the saddle and between the ways of the lathe is the forked bracket D, which supports the shaft E and also forms a pocket to retain the driving gear F and operating link I in a fixed position relative to the main saddle. The intermediate shaft G connects the lead screw gear H by means of the two links I and J, which keeps the gears always in mesh but permits of lateral adjustment to the cross slide. The lead screw K is fitted

shaft being free to oscillate, but having no lateral movement. On the outer end of the shaft M is the flange O, which carries the bolt for securing the cutter P in the desired position. To prevent the pressure of the cut being transmitted to the feed nut, the collar Q is provided with a shoulder that rests upon the stop S. The tool Q, held in the front tool holder, is used for turning the diameters of the adapters, while the tool R in the rear post, is for rounding off the corner of the pilot. The operation is as follows:—

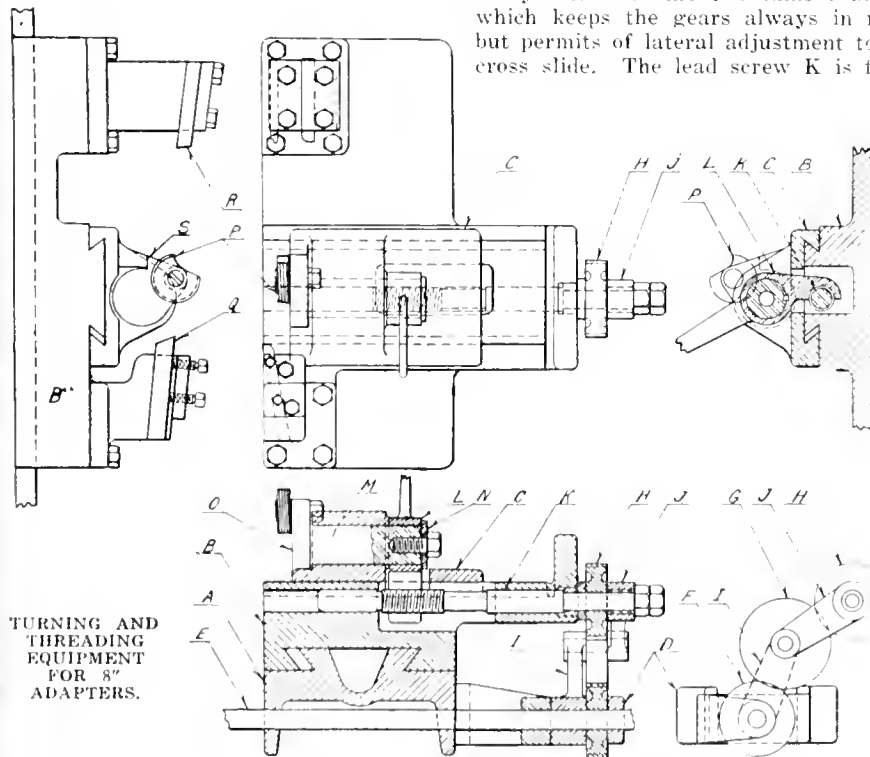

TURNING AND THREADING EQUIPMENT FOR 8" ADAPTERS.

finishing of 8-inch adapters. Fitted to the main saddle is the special cross slide B, which in turn carries the tool slide C, which operates at right angle to the cross slide and parallel to the axis of the lathe spindle. Secured to the lower part

in suitable bearings so that the central line of the shaft is parallel to the slide C, and likewise the lathe spindle. The operating nut forms the lower portion of the bell crank lever L, which is keyed to the end of the short shaft M, this

When the adapter has been secured in the collet chuck and turned to size with the tools in the front and rear holders, the saddle is moved to the desired position for threading. The auxiliary lead screw K is revolved at the desired speed through the train of gears F, G, and H; the first-named, F, being feathered to the driving shaft E, which is driven by means of gearing at the head end of the lathe, this being set up in the ordinary way to cut the required pitch of thread. With the saddle in the correct position, the threading tool P is set in the usual manner by the movement of the cross slide, the operating handle T being graduated for close adjustment with an indicator finger U located at the top. The block V can be secured at any point around the circumference to determine the final position of the cut, as it comes in contact with the stop held in the block W fastened to the saddle of the lathe. At the completion of each cut, the handle L is pulled forward, thus releasing the nut from the screw, and the slide with the screw cutting tool is brought back to its initial position. This method of finishing the adapters has proven very satisfactory and highly efficient.

MATHEMATICS IN THE TOOL ROOM

By N. E.

THE accomplishment of certain complicated machining operations in the jobbing shop or tool room, are generally performed by laying out the work with suitable tools, and working to the lines or dimensions thereby obtained. In order that accuracy may be maintained, it is often desirable, or even essential, that calculations be made involving the use of mathematics, so that the work can be checked after the work has been completed; or, as is often the case, before the work can be commenced. In the accompanying sketch is shown a shaper job that necessitated some figuring before actual machining operations could be started. A short length of shafting 6 inches in diameter, required a V-shaped groove of 60 degrees included angle, cut longitudinally, so that the opening B-C, across the top, would be 3½ inches; the total width of the chord A-D, on the cylindrical section, to be 5 inches, and the width of the bottom of the groove E-F to measure the same as the flats A-B and C-D, on the upper surface, at either side of the groove. As the width E-F was to be the chord of an arc, the extremities E and F being tangent to the sides of the groove, it was desired to find the diameter of the hole required to give the correct chord, and the position of the centre P, or its distance on the centre line from the shaft centre O. It was also desired to know the distance I, measured on the centre line X-Y.

While this problem could be worked out in the ordinary method of laying it off on the end of the shaft, it does not give any means of checking the various dimensions after the work has been completed. To work out this problem by calculation involves the use of a certain knowledge of mathematics that should be more or less familiar to those mechanics who, from time to time, may be confronted with work of a similar character. As the width across the flat A-D is known, the shaping of this portion can be easily accomplished, but no check is given as to the proper dimension of the distance I. To obtain this, it is necessary to solve by the solution of triangles, for the dimension O-H. In the solution of right triangles it should be remembered that if the lengths of two sides are known, the third can be found by the axiom that the square of the hypotenuse, or longest side, equals the sum of the squares of the other two sides. Where the hypotenuse and one of the sides are known, the square root of the difference of their squares, will equal the length of the third side; therefore, from the sketch the formula will be:—

$$\sqrt{(O-D)^2 - (H-D)^2} = O. H., \text{ or}$$

$$\sqrt{3^2 - 2.5^2} = \sqrt{9 - 6.25} = \sqrt{2.75} = 1.658 \text{ inches; the distance I will be O-H plus the radius of the shaft, or } 4.658 \text{ inches.}$$

In every equilateral triangle the three sides are all of the same length, and the angles are similar, therefore, G-C and B-G are equal to B-C, or 3½ inches; and

likewise, E-G and G-F are equal in length to E-F, or .75 inch. To find the position of the point G, we use the formula H-G

$$\sqrt{3.5^2 - 1.75^2} = \sqrt{9.1875} = 3.031 \text{ in.}$$

To find the position of the centre P of the drilled hole, it is necessary to solve the right triangle GFP for the length

G-P, by using the formula, hypotenuse side-adjacent divided by the cosine of the angle PGF, or .75 divided by .86603 equals .866 inch. As the three sides of an equilateral triangle are of the same length, it is obvious that the distance F-P, or the radius of the hole, will be one-half the length of the distance G-P, so the diameter of the drill to be used will be approximately 55/64 inch, or .866 inch. Then the dimension K, or the distance between the centre of the hole and that of the shaft (one the centre line), will be (O-X) - [(H-X) - (G-H) + (G-P)] = 3 - (4.658 - 3.031 + .866) = .507 inch. The dimension J will be O-K - (O-P P-F) = 3 - (.507 + .433) = 3 - .940 = 2.060 inches.



ROUGHING PROFILE ON 18 PDR.

H. E. SHELLS

By B. S.

OWING to the parallel bore of the 18-pdr. high explosive shells, it is unnecessary to close in the nose in order to form the profile, and to give the shell the conical shape and reduce the diameter of the body so as to meet that of the base of the fuse, the surplus metal is removed by machining. Many methods have been adopted for this operation, due largely to the varied experience of the different manufacturers and the equipment they have to work with. With few exceptions the general practice is to cut this metal off by using box tools, these being arranged either in a stationary or moveable position; the former in the case

where the shells are held in a chuck secured to the spindle of a lathe or drill press, and the latter where the shells are held firmly in a fixed chuck and the tools secured to the moveable member. The cut herewith illustrates a box bolted to the ordinary cross-slide tool rest, which is located in a central posi-

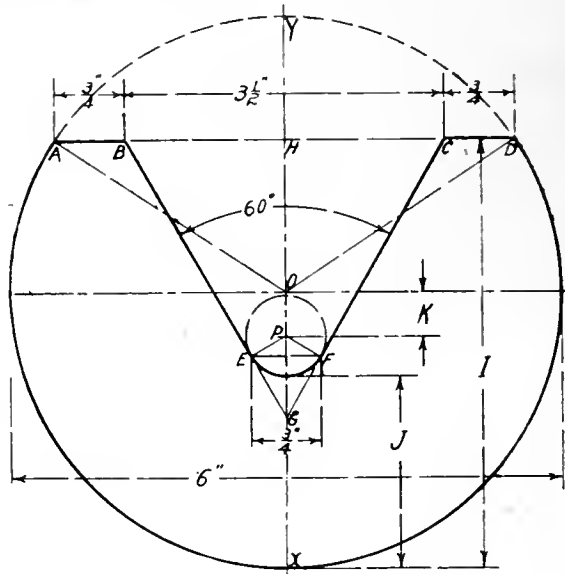

MATHEMATICS IN THE TOOL ROOM.

tion with that of the lathe spindle. The shell A is held in the collet chuck B. The box tool holder is clamped to the cross slide as shown, and lined up if necessary to a central position, the two tools E, one on either side, being ground to the desired shape of the profile and adjusted to correct position by means of the two set screws passing through the piece F, which is bolted and doweled to the body of the holder. The tool G, placed at right angles to the axis of the spindle, is set for facing the end of the shell and cutting the bevel for the seat of the fuse. The shaft H is secured to the centre of the holder and enters the bore of the shell, bearing on the inner base to gauge the final position of the profiling and facing tools. The tube I, shown at the top of the tool holder, is for the entrance of the cutting lubricant.

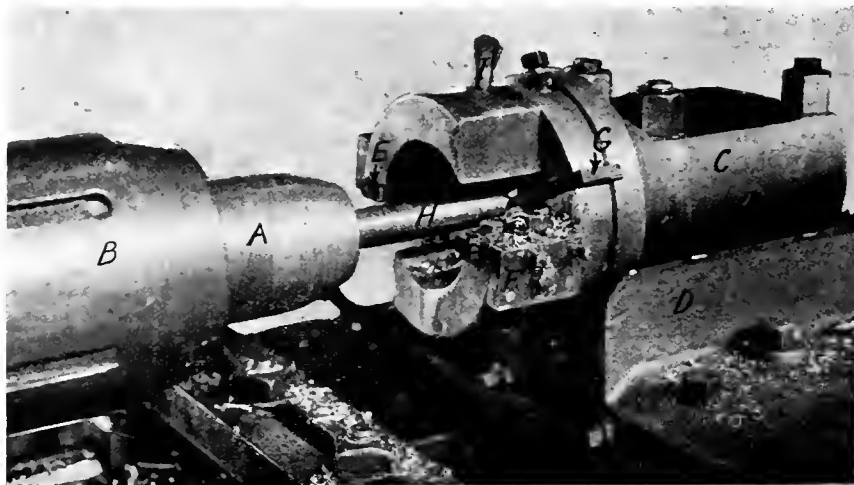

ROUGHING PROFILE ON 18-PDR. H.E. SHELL.

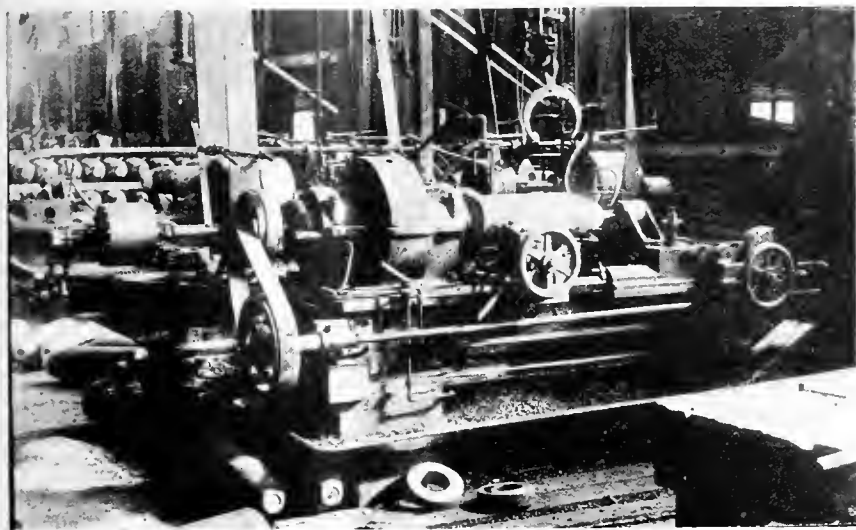

FIG. 1. CUTTING OFF OPEN END AND DRILLING NOSE—SPECIAL SHELL MACHINES

that shown in Fig. 1, where the open end is being cut off while the nose is being drilled, two saddles are provided so that the cross and longitudinal feeds can be operated at one time. The lathe illustrated in Fig. 1 is provided with a pneumatic cylinder for operating the expanding arbor that supports the shell. The forward saddle, or that nearest the head stock, has no lateral movement, except as is required for the setting in position, which when once set, is firmly locked to the ways of the lathe. On this particular machine, this cross slide is used for cutting off the open end to the required length for further machining. The moveable saddle at the rear is fitted with a fixed saddle block on its upper surface, the hole that supports the drill being in line with the axis of the lathe spindle. As the nose of the shell has been previously centered in relation to the rough bore, it provides a good start for the drilling operation, which necessarily must be accomplished at a slower speed than would be employed if this operation was performed separately, but as the drilling of the nose is performed during the time that the base is being

it being in a position for most efficient application.



SPECIAL SHELL MACHINES

By J. H. R.

THE accompanying cuts illustrate a couple of machines designed and constructed by the Ingersol-Rand Co., of Sherbrooke, Que., for the production of 8-inch high explosive shells. In developing equipment for munitions purposes, this firm has, as far as possible, utilized one design of machine, modifying it where necessary to better suit the particular operation for which it is to be used, and yet, if desired, capable of being set up to perform another service, by the addition or subtraction of certain parts or attachments. By this method it has been possible to make many of the parts or details of a uniform character, and interchangeable if desired. The general practice has been to construct these machines with one speed for the lathe spindle, any variation from the designed speed being afterwards obtained by the size of pulley on the overhead shaft. Separate mechanism has been provided

for operating the feeds; the parallel or axial movement being obtained by means of the gearing at the front of the machine, while the shaft that operates the

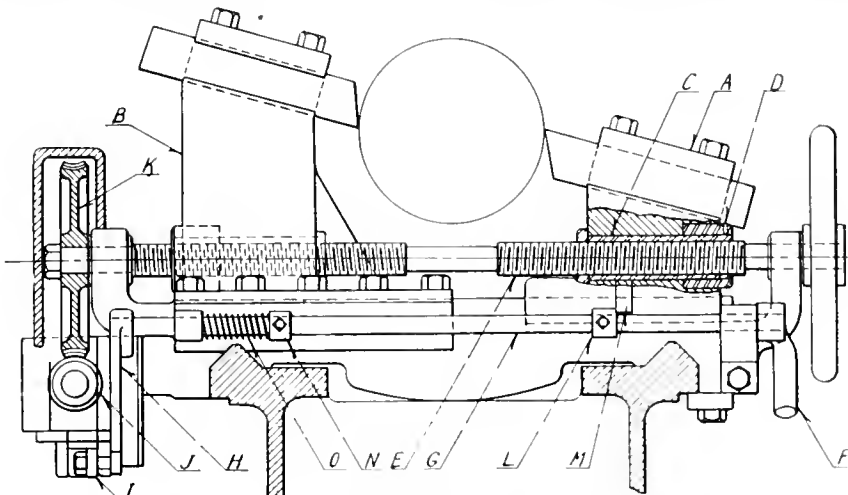

FIG. 3. CROSS FEED ON SPECIAL SHELL MACHINE.

cross feed is placed at the back of the lathe. Where it is possible to perform two operations at the same time, such as

cut off, the time otherwise required for drilling is thereby saved.

Fig. 2 shows a view of the machine as designed for roughing the 8-inch adapters. As in the case of the unit above described, the two feeds are operated independently, this machine showing the arrangement of the mechanism for operating the cross feed. A feature in the design has been the extensive use of standard wood pulleys, these being generally adopted for the feed pulleys on the various machines. Where it was found possible, after experiment, that heavier feeds could be used to advantage, it was an easy matter to change the size of the pulleys to obtain the desired result. The line drawing, Fig. 3, shows the arrangement of the cross feed as applied to the cutting off machine, the principle being identical to that on the other machines where cross feed is required. In both the front tool holder A and the rear tool holder B, is secured a special nut C, which in turn is held in position by the lock nut D extending well into the body of each tool post. The

(Continued on page 569)

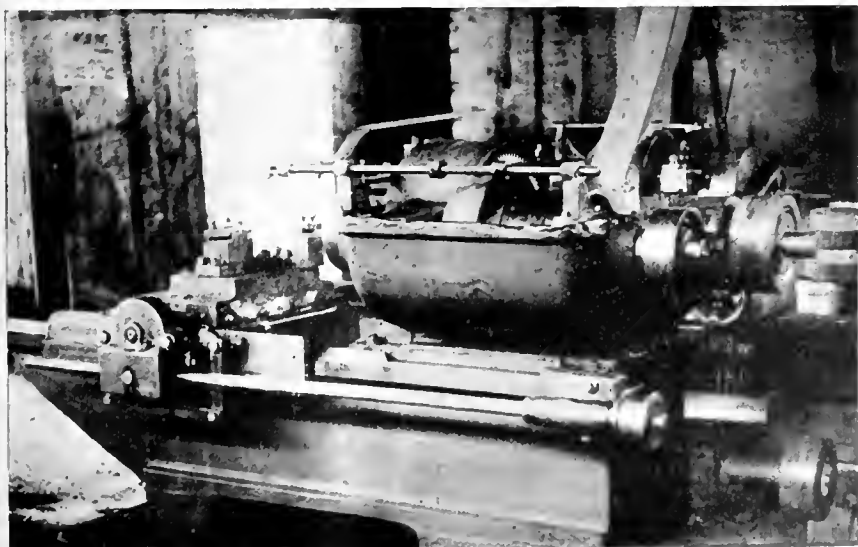

FIG. 2. ROUGHING ADAPTERS SPECIAL SHELL MACHINES.

High Pressure Air Compressor Design and Application*

By Joseph M. Ford

Compressed air at high pressure is becoming an increasingly important medium in modern engineering practice and in naval warfare. The accompanying paper deals with the machines which produce high pressure air, leaving on one side the question of power transmission by compressed air. In passing, the principal advantages of this system are referred to, and will be seen to be of considerable value. They consist of the facility with which energy can be stored; the unlimited rate at which accumulated energy may be converted into useful work; and, apart from loss of efficiency, leakage cannot cause any awkward consequences.

ONE of the best instances of the adoption of high-pressure air as a medium for power storage is to be found in torpedo work. The torpedo is launched from the tube by means of compressed air, usually stored at a high pressure, and when in the water is propelled by an engine de-

in submarines the air is used, among other things, for blowing the ballast tanks.

Pressure Adopted in Practice

Within limits, the lower the working pressure of the air, the higher the efficiency, but exigencies of space and weight may demand that the storage reservoirs shall occupy minimum space, in which case, for a given amount of energy stored, the pressure should be as high as possible—particularly, for instance, in a torpedo, where the dimensions and weight of power plant must be cut down to a minimum, almost irrespective of cost, and the pressures employed range accordingly from 2,000 to 4,000 lbs. per square inch.

With internal combustion engines, the design and type determine the pressure of the starting air. For example, gas, paraffin and petrol engines are frequently started with air at 100 to 300 lbs. per square inch. With Diesel engines of the four-cycle type about 300 lbs. per square inch usually suffices, whereas in engines of the two-stroke type the pressure may be as high as 1,000 lbs. per square inch. One of the disadvantages of using high pressures in this connection is that when starting a refractory engine—which does not readily pick up on fuel—the continued expansion of high pressure air in the working cylinders lowers the tempera-

ture to such an extent that the heat of compression is insufficient to ignite the injected oil. With reversing mechanism the obvious advantage accruing from the use of air at high pressures is that the

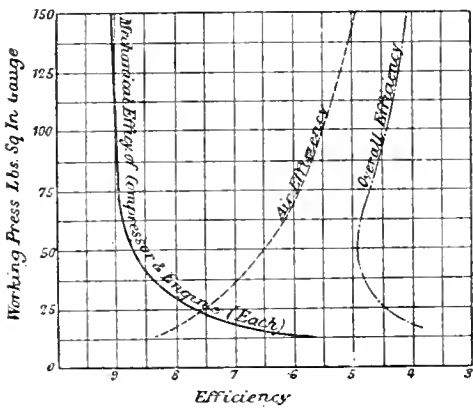

FIG. 1. SINGLE STAGE COMPRESSED AIR POWER TRANSMISSION. NO PREHEATING. MECHANICAL EFFICIENCY OF ENGINE ASSUMED TO BE SAME AS THAT OF COMPRESSOR. COMPRESSION IN LATTER AND EXPANSION IN ENGINE ASSUMED TO BE ADIABATIC.

giving most of its power from compressed air.

The starting of prime movers of the internal combustion type of considerable size is almost invariably carried out by compressed air, except perhaps in very special cases, such as some generating sets, where the dynamo can be "motored."

In marine work, with engines of the Diesel and other types, reversing and manoeuvring involve the displacement of a considerable amount of the valve-driving mechanism—most conveniently accomplished by compressed air.

One of the principal applications, however, is in the Diesel engine works, where compressed air is used, not as a medium for energy storage in the usually accepted sense of the term, but to inject the liquid fuel into the working cylinders against the compression pressure of about 30 atmospheres (430 lbs. per sq. inch.)

In some oil-engined ships, high-pressure air is used for driving some auxiliaries, such as steering gear, main engine turning gear, small pumps, etc., and

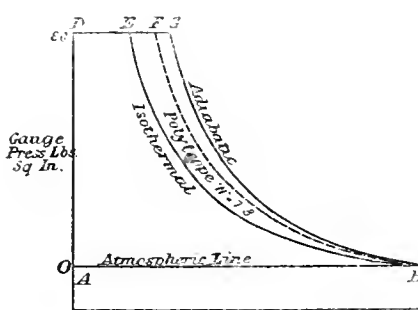

FIG. 2. Temperature-entropy diagram for compression of 1 lb. of air from 14.7 lb. to 94.7 lb. per sq. in. abs. Initial temperature of air... 60 deg. F. Initial pressure... 14.7 lb. per sq. in. abs. Final pressure... 94.7 " " "

WORK REQUIRED TO COMPRESS AND DELIVER 1 CUB. FT. OF FREE AIR.

- (i) Isothermal compression 3950 ft.-lb.
- (ii) Polytropic compression ("N"=1.3) 4950 "
- (iii) Adiabatic compression 5275 "

In this case 30 per cent. more work is required for adiabatic compression than for isothermal compression. Hence note importance of cooling during compression.

TEMPERATURES ATTAINED AT END OF COMPRESSION.

- (i) Isothermal compression 60° F.
- (ii) Polytropic compression ("N"=1.3) .. 335° F.
- (iii) Adiabatic compression 435° F.

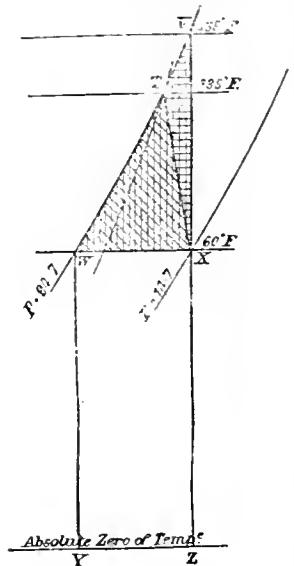

FIG. 3.

Temperature entropy diagram for compression of 1 lb. of air from 14.7 lb. to 94.7 lb. per sq. in. abs. Heat equivalent of work required for isothermal compression = area WYZ. Heat equivalent of extra work required if compression is adiabatic = area VWX (vertical shading). Heat equivalent of extra work required if compression is polytropic = area TWX (diagonal shading). Heat equivalent of work saved by cooling shaded horizontally.

dimensions of the servo-motors may be kept within small limits, which is of moment in some installations, although the higher the pressure the more difficult it is to maintain tightness and the better must be the fits, etc.

For fuel injection, the air pressure is determined by the theoretical cycle of operations in the working cylinder, and varies from 600 to 900, and in extreme cases even to 1,000 lbs. per square inch, according to the particular design of engine, kind of fuel and load.

The question of driving auxiliaries by compressed air is a vexed one. Unless the air can be heated before expansion in the engine cylinder, low initial pressures should be used. With high pressures the re-expansion lowers the air temperature so much, due to work being done by the air, that snow forms and interferes with the working of the valves.

*Part I. of a paper read before the Greenock (Scotland) Association of Shipbuilders and Engineers.

throttle passages, etc. Fig. 1 shows the theoretical efficiency of a transmission system when there is no pre-heating. The mechanical efficiency of the engine at the different pressures is assumed to be the same as that of the compressor at the corresponding pressures. The "air efficiency" is the ratio of work obtained from the air in the engine to the work done on the air in the compressor. A considerable gain in efficiency may be effected if the air can be heated before use, especially when this can be inexpensively done—e.g., by the exhaust gases of an internal combustion engine. The advantages of this system are nullified, more or less according to particular circumstances, by the low efficiency. Practical considerations, such as the question of leaks, etc., favor low pressures, whereas such considerations as the size of pipes, cylinders and storage generally demand a compromise, although it is cheaper to make an efficient large low-pressure reservoir than a satisfactory small high-pressure one.

Simple Air Compression

By way of introduction a few points on the elementary thermodynamical aspect of air

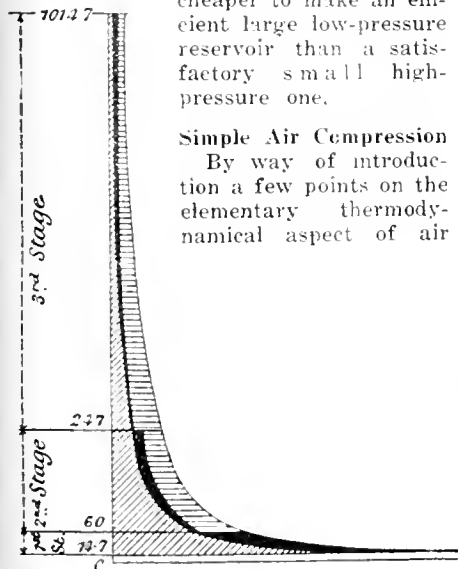

FIG. 1. PV DIAGRAM.

THEORETICAL DIAGRAMS SHOWING SAVING EFFECTED BY STAGE COMPRESSION. COMPRESSION TO 1,000 LBS. PER SQUARE INCH GAUGE.

In an ideal compressor, i.e., one in which compression is isothermal, the work required per unit of air is represented by the diagonally shaded area of each diagram. If compression were carried out in one stage the work required is represented by the total area of the diagram. The horizontally shaded area represents the work saved by compressing in three stages and intercooling. The darkly shaded area represents the amount by which the work required for three-stage compression is still in excess of the ideal. Note the huge saving of three-stage over one-stage compression. In this case the saving is 29 1/2 per cent.

compression may assist towards the understanding of the special features of high-pressure compressors. If air be compressed isothermally, a certain amount of work has to be done—see Fig. 2, giving a theoretical indicator diagram for a machine delivering air at 80 lbs. per square inch. With isothermal compression the work required is represented by the area ABED. If the compression be adiabatic, then the additional work required is represented by the area BGE, from which it will be seen that the aim should be to secure isothermal compression, that is, to prevent increase of the temperature of the air during compression. Not only from the point of view of power absorbed should the temperature rise be small, but also for mechanical reasons, as later explained.

The index "n" in the standard equation

$PV^n = C$ is in some ways a measure of the amount of heat abstracted during compression. With adiabatic compression its value for diatomic gases such as air is 1.41, and with isothermal compression its value is unity. In actual practice the amount of heat removed by a water-jacket on an air compressor cylinder is such that its value lies between about 1.28 and 1.35, the latter value being more applicable to large high-speed machines.

The line BF on Fig. 2 represents compression according to the law.

$$PV^{1.2} = \text{constant.}$$

This means that the saving in work effected by cooling the air during compression is represented by the area BGF. Moreover, the reduction in the final delivery temperature is to be noted.

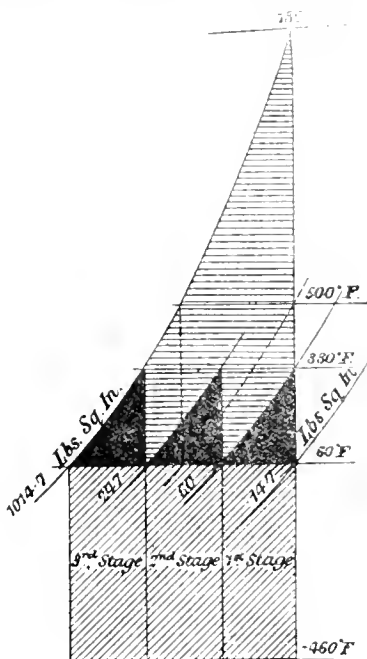

FIG. 5. Oo DIAGRAM.

The diagram in Fig. 3 is the "theta" "phi" diagram corresponding to Fig. 2. This shows rather more clearly the difference in the work required and temperature attained by compressing under the various conditions. The figure is self-explanatory.

Compression in Stages

When pressures of 1,000 lbs. per square inch and over are required, the temperatures attained by single-stage compression would be extremely high. If lubricating oil could be eliminated from the problem, careful design might succeed in producing a compressor that would stand the stresses set up by the high temperatures.

Lubricating oil burns in air at such temperatures, with the result that the pistons would become carbonized, the

valves clogged and the pipes sooted-up. In addition, high temperatures have deleterious effects on tempered steel valves and springs. With large high-speed machines the temperature, coupled with the peculiar fatigue phenomenon, makes it well nigh impossible to get satisfactory working with temperatures higher than those consequent upon about six compressions in one stage.

If the excessive work of compression and high temperatures are to be avoided, the heat must be abstracted from the air in the period between the start of compression and the commencement of delivery. Jacketing alone is insufficient. The method that suggests itself is to compress the air a small amount, then withdraw it from the cylinder, cool it to atmospheric temperature, and return it to the cylinder. Next, move the piston further to compress the air still more, and repeat the cooling process, and so on, until the required pressure is attained. This is virtually the method adopted in practice, except that in lieu of carrying out the whole process in a single cylinder, one cylinder is devoted to each stage of compression, and between each stage the air is passed through an intercooler to reduce its temperature to the initial atmospheric temperature. The saving in work effected by stage compression with intercooling is shown in Figs. 4 and 5. The PV diagram, Fig. 4, has been drawn for a three-stage machine compressing to 1,000 lbs. per square in.

If the heat of compression could be removed as fast as it is generated, as with isothermal compression, the work required to compress unit volume would be represented by the diagonally-shaded area. This is the ideal condition. If the compression were carried out in one stage and no heat were removed—that is, if the compression were adiabatic—then the work required to compress unit volume of air would be represented by the total area of the diagram, that is, the diagonally, plus the black, plus the horizontally shaded part. The ratio of this total work to that required in isothermal compression will be noted. If, again, the air were compressed adiabatically to 60 lbs. per square inch only and then cooled to its initial temperature, its condition will then be the same as it would have been had it been compressed isothermally. From this point the second stage of compression is carried out and the cooling process repeated, meaning that the area of the second stage diagram is only the diagonally shaded portion plus the black portion, the horizontally shaded part being completely saved, due to the reduction in the volume of air dealt with, as a result of the intercooling.

Similar conditions obtain in the third stage, the horizontally shaded part again representing work saved. The work required for adiabatic compression in three stages is thus represented by the diagonally shaded portion plus the black portion, which latter represents the amount by which the work required is still in excess of the ideal.

Fig. 5 is the "theta" "phi" diagram corresponding to the PV diagram in Fig. 4.

The corresponding areas are similarly shaded. In addition to the work required, this diagram shows the temperatures attained in compression under the various conditions. The reduction of the temperature due to staging is clearly shown. The 1,300 deg. F. is a theoretical value, 500 deg. F. is the temperature which would be attained were the compression carried out in two stages, and 330 deg. F. is the result of three-stage compression. In the case under consideration the total work is equally divided between the stages, whereas in actual practice this condition does not generally hold exactly.

The temperatures attained in the cylinder when air is compressed to various pressures in one, two or three stages, with intercooling, are given in Fig. 6. Piston friction and the effect of the cylinder walls have been neglected. As previously stated, the high temperatures could not be dealt with in practice. The temperatures given for two and three-stage compression are based on the assumption of perfect intercooling, which

cubic foot—an increase of 5 per cent., against the 15 per cent. obtained when compression is carried out in a single stage.

Apart from the questions of efficiency and temperatures, an advantage of staging is the reduction of crankpin loads and stresses generally—the reasoning being exactly the same in this connection as for a compound or triple-expansion steam engine. Theoretically an infinite number of stages is required, but practical considerations, such as the multiplicity of parts, the low mechanical efficiency, weight, cost, etc., limits the number of stages.

Pressures and Number of Stages

The best practice is as follows: The maximum terminal pressures are, for one stage, 80 to 100 lb. per square inch; two stages, 600 lb. per square inch; three stages, 1,500 lb. per square inch; four stages, 2,500 to 3,000 lb. per square inch; five stages, 4,500 lb. per square inch; and above 4,500 lb. per square inch, six or seven stages to 6,000 lb. per square inch,

stage compressor, such as would be used to drive pneumatic tools in a shipyard, the designer aims to reduce the cylinder clearance to the minimum, for by so doing a greater quantity of air is delivered per stroke than would be the case with a larger clearance. Fig. 8, which is a theoretical card for a cylinder compressing to 80 lb. per square inch, is given in explanation. With zero cylinder clearance the volume of air delivered is represented by CD, whereas with 10 per cent. clearance and the same cylinder dimensions the volume delivered becomes FD. Less air is drawn into the cylinder per stroke, since the air left in the clearance space re-expands along DE, for a portion of the suction stroke, as shown, and the suction valves do not open to admit a fresh supply of air until the point E in the stroke is reached. In this way the volume of air aspirated is only EB, as compared with AB—the volume dealt with in the same cylinder without clearance. The

EB
ratio — is known as the Indicated Vol-
A B

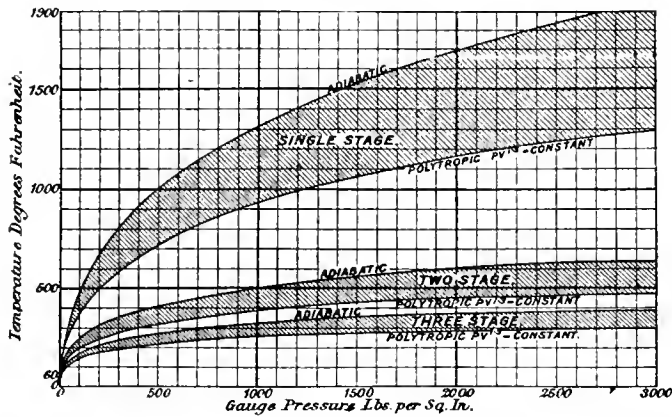

FIG. 6. TEMPERATURES ATTAINED WITH ONE, TWO AND THREE-STAGE COMPRESSION TO VARIOUS PRESSURES. INITIAL TEMPERATURE IN EACH STAGE OF COMPRESSION ASSUMED TO BE 60° FAH.

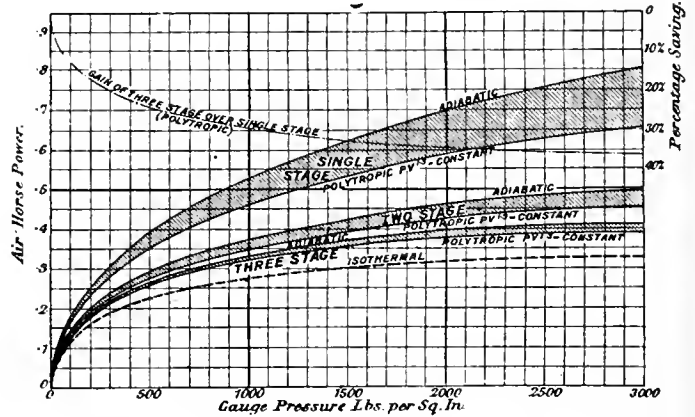

FIG. 7. AIR HORSE-POWER REQUIRED PER CUBIC FOOT FREE AIR PER MINUTE WITH ONE, TWO AND THREE-STAGE COMPRESSION TO VARIOUS PRESSURES.

condition holds for well-designed machines. In some plants where there is a copious supply of cold water, and where intercoolers of liberal dimensions are fitted, the air can be cooled between the stages to less indeed than the initial temperature.

Fig. 7 gives the air horse-power required to compress 1 cub. ft. of free air per minute in one, two and three stages to various pressures, and shows how the power required approaches the ideal (isothermal compression), and the ill-effects of inefficient jacketing diminish as the number of stages is increased. For example, with air compressed to 1,000 lb. per square inch in one stage, according to the law $PV^{1.3} = \text{constant}$, the power required would be 0.46 a.h.p. per cubic foot; but if the cooling were very inefficient, so that the compression were adiabatic, the power would rise to 0.53 a.h.p. per cubic foot—an increase of 15 per cent. With three-stage compression, according to the same law, the power required would be 0.32 a.h.p. per cubic foot, and in this latter case, assuming that the cooling were inefficient, the power would only rise at the most to 0.335 a.h.p. per

which is about the highest pressure for which an air compressor has been constructed.

In the case of very small machines these pressures, for a given number of stages are often exceeded in order to reduce complication. For example, machines have been constructed and work quite satisfactorily when compressing to 2,500 lb. per square inch in two stages. The temperatures attained, however, make it necessary to carry out the cylinder lubrication by soapy water.

Effects of Cylinder Clearance Volumes

An important consideration in the design of a multi-stage compressor is the computation of the clearance volumes of the various cylinders. By clearance volume is understood not merely the volume of the space which separates the piston from the end of the cylinder when the crank is on dead centre, but, in addition to this, the volume of all valve ports and pockets, space behind piston rings if these are air-packed, and, in short, any space into which the air can be compressed, without passing through the delivery valve. With an ordinary single-

umetric Efficiency, and in this particular case is about 69 per cent. The smaller the clearance space, the nearer will E be

EB
to A, i.e., — will be greater, and a larger
A B

volume of air will consequently be dealt with per stroke.

With a large clearance a larger cylinder is required to deliver a given amount of air than with a small clearance, yet the indicated work done per unit volume of air dealt with remains the same, although the larger cylinder makes for a heavier and more costly machine, with greater piston loads, so that in general practice the clearances are made as small as possible. Referring again to Fig. 8, the higher the compression is carried, the further will E be removed from A, that is, the higher the delivery pressure at which a given cylinder is working, the less will be the indicated volumetric efficiency. Further, if the clearance air receives heat from the cylinder and piston whilst expanding, the law of expansion will approach the isothermal and the pressure of the clearance air will take the longer to drop to the suction pressure,

or E will be still further removed from A to G.

It is to be emphasized that the air should not receive heat whilst re-expanding, or, in other words, the clearance space should be as efficiently cooled as possible. The cooler the walls of the

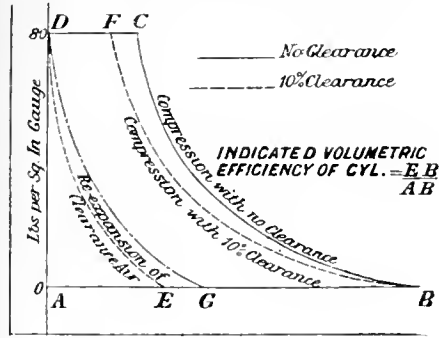

FIG. 8.

clearance space, the more rapidly will the pressure of the re-expanding air fall to the suction pressure and the greater will the ratio $\frac{EB}{AB}$ become. Moreover, if

$\frac{EB}{AB}$

the clearance air receives heat whilst re-expanding, its temperature at point E will be considerably higher than the temperature of the incoming air. As a result of the mixing of the new supply with the hot clearance air, the temperature at the end of the suction stroke, i.e., at B, will be higher than it would have been had there been no hot air left in the cylinder at point E, thus reducing the weight of air dealt with per stroke and increasing the temperature of compression. In any case the temperature of the air at B must be higher than that of the suction air, owing to contact with the hot walls and piston.

In modern practice, the cylinder clearance volume for a single-stage compressor or low-pressure cylinder of a multi-stage machine is seldom less than 3 to 4 per cent. of the volume swept out by the piston. It is usually found that, within limits for practical reasons, the larger the machine, the smaller the percentage clearance.

If a single-stage machine were constructed to compress to a moderately high pressure, say, 165 lb. per square inch, the indicated volumetric efficiency at the best would not be more than about 80 per cent., whilst the ratio of volume of free air delivered to volume swept by piston would be very much lower still, due to the addition of heat before compression commenced. Further, the cross-head loads would be very great, due to the final delivery pressure being exerted on the whole area of the large piston. The twisting moment diagram for the machine would be uneven, and, perhaps of most consequence, the final delivery temperature would be excessively high.

If, on the other hand, the same size of cylinder were used with a high-pressure cylinder added thereto, so that the first only compressed to 37 lb. per square inch, the indicated volumetric efficiency would be increased to about 94 per cent., due to the lower delivery pressure bringing the

point of the low-pressure diagram corresponding to E in Fig. 8 nearer to A. With the high-pressure cylinder mounted in tandem with the low-pressure, it is possible that the weight of the machine per unit of air delivered would not be more than when the compression was carried out in one cylinder. Staging nullifies to a large extent the effects of clearance volume on the volumetric efficiency of a compressor, besides obviating the difficulties with loads and temperatures.

In both the French and German languages the expression for clearance volume, literally translated, means "injurious space," yet the effects of clearance in some cases are beneficial. In a cylinder with no clearance the whole load at the commencement of the stroke due to the acceleration of the moving part comes upon the crank-pin. With clearance, the re-expansion of the clearance air helps largely to accelerate the masses, and an interesting case in this connection may be cited.

With steam-driven compressors it is common practice to mount the steam cylinders in tandem with the air cylinders, in which case the setting of the steam valves must be so arranged that admission is late instead of early, as is usual. If the full steam pressure were applied to the piston before the clearance air pressure in the air cylinder had become reduced by re-expansion, unnecessarily high loads due to these simultaneous full pressures, less the inertia effects, would be imposed upon the connecting rods, etc. High speeds with increased inertia forces tend generally to reduce crank-pin loads. With steam-driven compressors of the foregoing type the greater the clearance volume of the air cylinder the later must the steam admission be timed.

Effects of Clearance in the Higher Stages of a Multi-Stage Compressor

In a multi-stage compressor the work done in the various stages may be varied within fairly wide limits merely by adjusting the clearance volumes of the various cylinders, excepting the low pressure. Suppose, for example, it is required to reduce the proportion of work done in the high-pressure stage of a three-stage compressor in which the high-pressure clearance volume is 10 per cent., and with stage pressures—low pressure 45 lb. per square inch, intermediate pressure 300 lb. per square inch—working against a final delivery pressure of 900 lb. per square inch.

The work done in compression varies as the ratio of final to initial pressure, so that any desired reduction in any given stage can only be effected by reducing this ratio, or in this case by increasing the high-pressure suction pressure, since the final delivery pressure is fixed. The compressor capacity being unaltered, an increase in the high-pressure suction pressure necessarily involves a corresponding reduction in actual volume of high-pressure suction. Since the volume swept by the high-pressure piston remains the same, it is clear that the

only way to ensure a reduced suction volume is to decrease the volumetric efficiency of the high-pressure cylinder by increasing the clearance volume, with the result as shown in Fig. 9, where the high-pressure diagram with the original 10 per cent. clearance, together with the diagram resulting from an addition of 20 per cent. extra clearance, are given. The area of the diagram is considerably reduced, the high-pressure suction pressure (the intermediate-pressure delivery pressure) rises from 300 lb. per square inch to 375 lb. per square inch (gauge-pressure), this increase being necessary in order to get the whole of the air into the high-pressure cylinder. The effect on the low-pressure delivery pressure is slightly to increase it, due to the reduced volumetric efficiency of the intermediate pressure cylinder, resultant upon the expansion of the intermediate pressure clearance air from a higher pressure. The actual increase in low-pressure delivery pressure depends upon the intermediate pressure clearance volume. If the intermediate pressure cylinder had no clearance volume, which is impracticable, the low-pressure pressure would remain unaltered. The slight increase in low-pressure delivery pressure somewhat reduces the volumetric efficiency of the compressor.

The simple method of altering the distribution of work would be convenient where the high-pressure delivery temperature was found to be excessive (see later), or in cases where the turning moment was unsatisfactory. The clearance volume can be increased by the addition of a hollow pocket, but cannot so easily be reduced.

Some multi-stage compressors are required to work for long periods at varying delivery pressures, or, in the case of a charging compressor, at a constantly increasing pressure from atmospheric to the full bottle pressure. With Diesel engines it is usual to regulate the blast pressure by throttling the fuel-injection

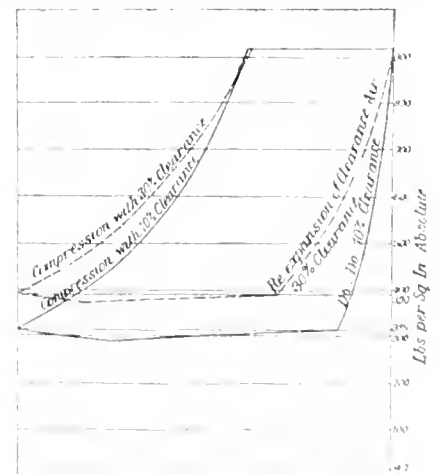

FIG. 9. DIAGRAM SHOWING RESULT OF INCREASING CLEARANCE VOLUME IN HIGH PRESSURE CYLINDER

air compressor suction, so that instead of compressing and blowing the excess to waste, only the requisite amount is dealt with. The effect on the distribution of work, temperatures, etc., occasioned by

this throttling should be considered—especially with marine engines, where the compressor may run for long periods in this condition.

In all machines there are certain stage pressures which give the best all-round running, as regards temperatures, loads, balance, etc., for each delivery pressure. If these stage pressures are accurately determined for the normal final delivery pressure, then it is safe generally to assume that the particular stage division of work so obtained will also be the best proportion for any other delivery pressure at which the machine is likely to work. With Diesel engine fuel-injection compressors this state of affairs rarely obtains. In a three-stage compressor designed for 800 lb. per square inch working pressure, and run at, say, 900 lb. per square inch, the low-pressure and intermediate-pressure pressures will not increase in proportion to the final delivery pressure—actually in the majority of cases they alter little. By suitably proportioning the cylinder clearance volumes of the various stages the machine can be made automatically to divide the total work between the stages in a given proportion, no matter what the delivery pressure may be.

Figs. 10 and 11 show approximately the stage pressures which would be obtained in three machines of the same capacity when working at different pressures. Each machine is designed for a delivery pressure of 900 lb. per square inch, and at this pressure the stage pressures are: low-pressure, 45 lb. per square inch (gauge pressure). The heavy lines on the diagram show what the pressures should be to secure an approximately constant proportional division of work between the stages. The lines marked (a) show the pressures which would obtain in a compressor having cylinder clearances of: low-pressure, 4 per cent.; intermediate-pressure, 5 per cent.; high-pressure, 10 per cent.

The rise in the stage pressures as the final delivery pressure increases is seen to be comparatively small. The lines marked (b) show the pressures with a compressor of the same capacity when the cylinder clearances are: low-pressure, 4 per cent.; intermediate-pressure, 10 per cent.; high-pressure, 20 per cent. Here it is seen that the rise in stage pressure is much more marked than in the first case, that is to say, with these increased clearance volumes the proportional division of work between the stages is more nearly constant than with the smaller clearances. The lines marked (c) give the pressures which would obtain with a machine having clearances: low-pressure, 4 per cent.; intermediate-pressure, 15 per cent.; high-pressure, 30 per cent.

In this case the rise in stage pressures as the delivery pressure increases approximates much more nearly to the "ideal;" that is, the proportional division of work between the stages is very nearly constant, so that the balance of the machine is more likely to be maintained than in the first case, and, further, the final delivery temperature will be lower, for in the first case, when the machine is

working at a pressure higher than its designed pressure of 900 lb. per sq. inch, the high-pressure stage is taking more than its designed share of the work. For example, if the first machine (case "a") were run at 1,200 lb. per square inch, the compression ratio in the high-pressure cylinder would be:—

$$\frac{1215}{375} = 3.24$$

If the last machine (case "c") were run at 1,200 lb. per square inch, the high-pressure compression ratio would be:—

$$\frac{1215}{370} = 3.28$$

This means that the temperature attained in the machine with the large clearance would be less than in the machine with the small clearance on account of the smaller compression ratio. Furthermore, if the large clearance is composed of a connecting pipe within a water-jacket, as is sometimes the case, the cooling during compression is improved, resulting in a decrease of the value of "n" in $PV^n = \text{constant}$, still

the machine with the big clearances is slightly less than that of the machine with the small clearances when the delivery pressure is higher than that for which the compressor is designed.

The difference, however, is not worth considering. (It may be mentioned that the lines in Fig. 10 should not actually be quite straight. They are sufficiently accurate, however, as in practice it is impossible to estimate the pressures to within a few pounds.)

THREE-CYLINDER COMPOUND ELECTRICAL UNIT

THE new 60,000 kilowatt unit to be installed in the 74th Street station of the Interborough Rapid Transit Co., New York, where three 30,000 kw. cross compound Westinghouse turbine generators have been in successful operation for over two years, will consist of a high pressure and two low pressure turbines, each coupled to a generator. Each of the three turbo generators making up the unit is to have a governor so arranged that if for any reason the circuit should

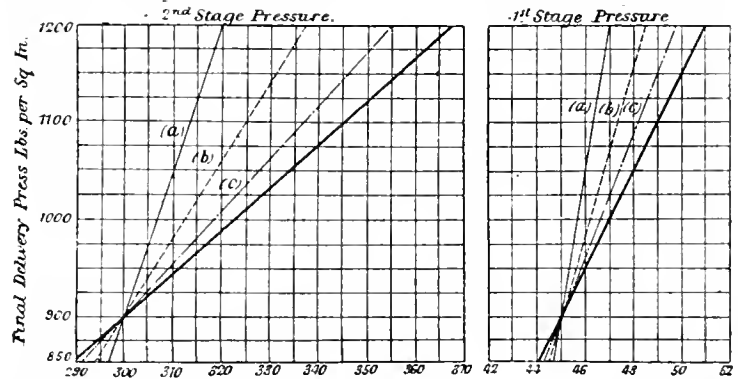

FIG. 10. DIAGRAM SHOWING APPROXIMATELY THE STAGE PRESSURES ATTAINED WHEN THE COMPRESSOR IS DELIVERING AGAINST DIFFERENT FINAL PRESSURES.

- Each machine is designed for a final delivery pressure of 900 lbs. per square inch with L.P. and I.P. pressures of 45 lbs. per square inch and 300 lbs. per square inch respectively.
- (a) For a compressor whose clearance volumes are: L.P., 4 per cent., I.P., 5 per cent., H.P., 10 per cent. of volume swept by piston.
- (b) For a compressor whose clearance volumes are: L.P., 4 per cent., I.P., 10 per cent., H.P., 20 per cent. of volume swept by piston.
- (c) For a compressor whose clearance volumes are: L.P., 4 per cent., I.P., 15 per cent., H.P., 30 per cent. of volume swept by piston.

The heavy line shows what the pressures should be if the division of work between the stages is to remain in the same proportion for all delivery pressures.

further reducing the temperature. Again the clearance space being so efficiently cooled results in an increase in the value of "n" for the re-expansion of the clearance air. The incoming air mixes with this comparatively cool air, and consequently the initial temperature is not unduly raised.

The main point, however, is that by correctly arranging the clearance volumes the machine can be made to divide the total work into the best proportions for any delivery pressure with which the compressor may have to deal. A minor point is that with increasing delivery pressures piston leakage becomes greater, and the volumetric efficiency at the higher pressures is less than at the lower. If the low-pressure pressure increases with the delivery pressure, the indicated volumetric efficiency of that cylinder is decreased in addition—or, in short, the overall volumetric efficiency of

open on the high pressure turbo generator, steam will be shut off from that particular one, and the two low pressure turbo generators will operate under governor control with high pressure steam. Likewise, should anything happen to both the high pressure and one of the low pressure turbo generators, or to the two low pressure turbo generators, the remaining one will operate and carry the load. The turbines which will operate at 220 lbs. absolute steam pressure, 120 degrees superheat, 20-inch vacuum, and the generators which will have a capacity of 60,000 kw. continuously, or 70,000 kw. for two hours, are being furnished by the Westinghouse Electric & Mfg. Co., of East Pittsburgh, Pa.

A person don't mo'n realize he's a descendant befo' he's a' ancestor.—Ruth McEnery Stuart.

EDITORIAL CORRESPONDENCE

Embracing the Further Discussion of Previously Published Articles, Inquiries for General Information, Observations and Suggestions—Your Co-operation is Invited

WIRE ROPES FOR COAL MINES

By O. C.

THE importance of the mine rope is often underestimated but it is the essential life line of mine. The wire rope, by means of which coal is hauled to the earth's surface, constitutes a most vital link in the long chain of processes by which the coal is got from the mine and made to give heat, light, power explosives and countless other products essential to mankind. The designer of haulage or lifting tackle, especially for mining work, has a most exacting task, in which he must exercise the greatest prudence and foresight. The nature of the appliance is generally such that the failure of one rope almost certainly means disaster. In such a structure as a bridge one or even several members may fail, but the others will generally keep the whole together till the danger has been observed and precautionary measures taken, but the mine cage hangs by one rope, and if this fail, there is nothing to prevent the load from falling to the bottom of the shaft.

Complex Stresses

The nature of the stressing of a rope is very complex. In the straight portion between the winding drum and the load there is a direct pull on the rope as a whole, and it might be thought that the load that the rope would carry is equal to the sum of the loads which each individual wire composing it will bear. Experience has shown that this is far from so and that the strength of the rope falls short of the aggregate strength of the wire by as much as 10 to 35 per cent. Even if a sample of a rope, when tested in direct tensions, breaks at a load seven, eight, or even nine times that of the working load, it cannot at once be assumed that it is safe for continued use, for there are severe stresses brought into play due to the passage round the winding drum or pulleys.

This passage round the drum induces bending stresses very similar to those which occur in a beam subjected to a bending load. The nature of the plaiting of the rope reduces the intensity of these stresses far below what they would be in a bundle of straight wires bent round the same radius. Even so, a reasonable figure for the bending stress on a rope designed to carry a load of 10 tons per sq. in. due to the suspended load, would be 30 tons per sq. in. in crane design. Thus the total stress on the part round the pulley would be 40 tons per sq. in. By using more wires in the rope of smaller size the bending stress is reduced in proportion. Similarly it may be minimised by using larger pulleys and drums.

The effect of bending is rendered more serious by its constantly fluctuating nature. As the rope raises and lowers the cage, and is loaded and unloaded, the stress in it fluctuates between zero and maximum load and this leads to what is known as "fatigue." When a material is subjected to such a fluctuating load it will break under a much lower stress than it would if the load were steady. This effect may be seen by taking a thin strip of iron or steel and clamping one end in a vice. If the other end be bent over, the strip if soft will bend through a right angle, without cracking. But if it be bent to and fro, a number of times through a smaller angle, it will break right across. Experience shows however that there is a safe margin, and if the stress on the ropes does not fluctuate beyond this margin it will last practically indefinitely.

Soft Versus Hard Wire

It seems fairly certain that a soft wire withstands fatigue better than a hard one and consequently wherever possible makers use soft Bessemer steel of 40 to 45 tons per sq. in. tensile strength, or at least mild steel of 95 to 100 tons per sq. in. in preference to the harder but stronger plough steel of 110 to 120 or 135 tons per sq. in. For shallow mines, Bessemer steel ropes are much the most economical in first cost, but in deep shafts the weight of the rope itself which has to be supported becomes a serious factor, and for a given load this will, of course, be three times as much for a rope of 40 tons per sq. in. as for one of 120 tons per sq. in. Thus it is advantageous, if possible, to employ hard wires for deep shafts. Fortunately it is possible to do this because the stress in the rope due to its own weight is so large, compared with the fluctuating load, as to damp out the effects of the latter. In addition, to the wearing strains already mentioned there is an effect due to the spiral lay of the wires and strands in the rope. The application of a pull makes these spirals unwind slightly, as does an ordinary spring. The slight movements of the wires against each other and against the pulley causes abrasion which has to be watched very closely in the periodical inspections of the ropes.

A rope experiences the greatest strain at, and before the moment of starting. Severe damage may be done if the load is thrown in to the cage too quickly, for if a load of say ten tons falls on a rope, suddenly, causing a shock, its effect is the same as that of a steady pull of twenty tons. During the first part of the wind, the load has to be speeded up from rest to a certain maximum speed of lift, so an extra force is needed to increase its speed, this being proportion-

al to the rate at which the speed is increased. Thus, if the speed be raised to 50 ft. per sec., in twenty seconds, the force needed to accelerate, the mass is twice as much as if the same speed were attained after forty seconds. This accelerating force or inertia force must be felt by the rope, if the latter is attached rigidly to the cage and must cause a severe stress in the early part of the lift. As the above figures show, the rate of speeding up should be kept as low as possible consistent with rapidity of delivery from the shaft.

Reducing Stresses

The stresses due to shock and inertia are often reduced by using a special spring attachment between the rope and the cage. Rubber buffers have been introduced between the pulley bearings and their attachment to the bracket on the roof of the cage, so as to give some spring to the pulley when the load is lifted. Various arrangements are in use though the use of rubber means that it perishes rapidly under the exposure to the weather, so springs were resorted to. Whatever is the means used, the principle is the same, namely to interpose a spring between the rope and the load so that shock and inertia forces acting on the cage extend the spring instead of the rope, which if the spring is of the proper stiffness is almost entirely relieved of all but the steady load.

Ropes must be inspected minutely at frequent intervals. The most serious wear takes place at the lower end where a cap or clip is attached. At this point, shock effects and the tendency of a long spiral to twist and untwist are felt most severely. At each inspection the cap should be renewed and this gives the opportunity to cut off a short length which can be tested in direct tension as well as being prised open to reveal its internal condition. The individual wires are clamped at one end and subjected to repeated twisting and bending till they break. The rope should be discarded if the sample wires will not stand a certain number of repetitions of each kind of test, the criterion being fixed according to the physical properties of the steel from which the rope was made. A good plan is to reverse the wire each time it is recapped, as by this means each end in turn bears the shock and testing strains, and thus the damage is equalised. Great care should be taken to lubricate the ropes by allowing them to run in a trough having brushes fitted with lubricant on either side. A mixture of tar, summer oil, mica and axle grease is a good mixture. This reduces the abrasive effects of the pulley on the outer wires and of the wires on each other, and increases the life of the ropes by as much as 25 to 50 per cent.

Fixing Limit to Life of Rope

One port authority in Britain, the Belfast Harbour Board, follows the life of each of their ropes most carefully. For much of the work a standard 3 in. rope is used working over a 22 in. pulley. No rope works for more than four months continuously, being given periodical rests. It is discarded regardless of its condition after lifting 10,000 tons, and with the large 7 in. rope a life of ten years is allowed. These figures relate to crane work and not mine work but they show the extreme care which is bestowed on these appliances by responsible engineers. Some of the South African mines are over a mile deep and the results of a failure are too disastrous to contemplate. It was the fall of 40 Kafirs through 4,000 ft. in Robinson's Deep mine which led to the abandonment of the flat rope, owing to the difficulty of inspecting it having allowed unsuspected faults to arise. The safest plan is undoubtedly to fix a length to its life and then discard it.



BY-PRODUCTS OF COAL DISTILLATION

By C. T.

THE abolition of smoke should be brought about simply and solely by distilling all coal before burning it. Everything at this moment combines to make this reform practicable, and it would effect a saving for the whole country of a hundred million pounds a year. First the increase of the price of raw fuel, quite apart from the war, has induced more care and thought as to its consumption. Next the advent of the internal combustion engine, by far the most simple, convenient, and economical prime mover so far discovered, has created an increasing demand with higher prices for benzol, gasoline and fuel oil. The passing of the horse and the gradual exhaustion of the nitrate beds of South America had led to higher prices for ammonia sulphate, which is one of the other valuable by-products of the distillation of coal.

No grate simple enough to be practicable will burn coal without smoke unless the coal be distilled first. Coke burns without smoke. Common gas coke, however, will not burn satisfactorily in many grates. Therefore special fuel must be made which will burn easily in an ordinary grate. Raw coal can be distilled at a lower temperature than is used in ordinary gas-making, leaving about 10 per cent. of volatile matter in the coke. This fuel burns with a cheerful flame in any grate. Distillation at low temperature, seems likely to be the prevailing method; otherwise too much gas would be produced and too little of the valuable tars. Low temperature distillation produces the best yield of valuable tars and oil—notably, it produced a spirit with all the properties of gasoline. Normally England imports one hundred million gallons of gasoline per annum. Up British

chimneys goes five hundred million gallons of gasoline per annum; and this is only one of the by-products of coal wasted in the riotous combustion of the open fire. The ammonia waste is still worse, for ammonia, if burnt, gives out no heat. It is a vital necessity in farming. Every ton of coal burnt might yield 50 cents worth of ammonia if distilled. From 200 to 250 million dollars worth of recoverable ammonia vanishes up British chimneys every year, with no return at all. A quarter of that could be easily retained by low temperature distillation.



POSITIVE AND FRICTION CLUTCHES

By T. J.

THE attempt to find a satisfactory form of clutch has yielded many excellent types and designs, but no clutch yet invented has shown such all-round superiority as to supersede all other designs. The claw coupling is the simplest and most effective of all clutches when once it is in action, for it consumes practically no power, and shows no wear, but it cannot be put in and out of a gear except at slow speeds, or when the machine is stopped. For a drive that can be connected or disconnected at full speed and under full load, some form of friction clutch is necessary. The cone clutch is the simplest of all friction clutches, and although innumerable other types of friction clutch have been introduced—segment clutches, band clutches, disc clutches, magnetic clutches, centrifugal clutches, etc.—it still remains a prime favourite. The conditions to be fulfilled by the ideal clutch are many and diverse. It must be simple in construction, and free from undue wear; it must engage smoothly, and when engaged must grip firmly, yet there must be no "bite" that will prevent easy disengagement; the grip must not be incurred at the cost of heavy pressure on the moving part, as there will be a wear and loss of power; the amount of movement required to put the clutch into action must not be too great, and yet the clearance when out of action must be such as to ensure that there is no rubbing. These are but a few of the conditions to be observed.

Theoretically the ideal clutch, as suggested by Mr. W. G. Gass, would be a combination of friction and positive clutch. It would employ a friction arrangement for starting up, and when that had done its part a positive drive would come into operation, and take all the work of driving off the friction surfaces. The designing of a combination clutch of this kind is not an easy matter. The difficulty would come in providing for its being thrown out of gear with the same ease as a friction clutch, for when the positive part of the clutch comes into action it is this part which will be doing the work, and will be under pressure, and to withdraw this part from engagement will present the same difficulty as is found with a claw coupling.

FACTOR OF EVAPORATION CHART

By N. G. Near.

THE term "Factor of Evaporation" is used a great deal in engineering — so much the writer thought it worth while to work up a chart on the subject in order that anybody can reduce ordinary heat values directly into factors of evaporation without doing any figuring.

For example, you look into your steam tables and find that the total heat in steam at a given pressure is 1,100 B.t.u. You also find that the feed water origin-

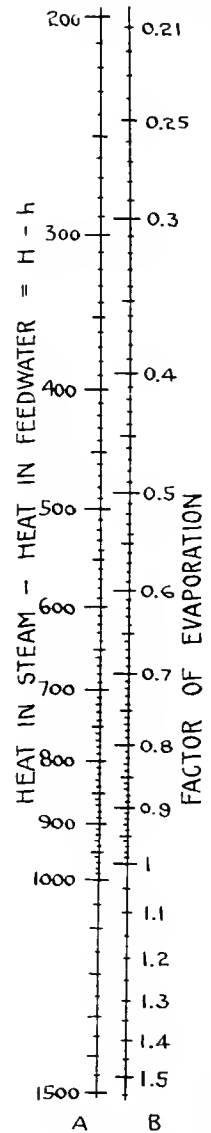

HANDY "FACTOR" OF EVAPORATION CHART.

ally contained 100 B.t.u. per pound. The difference H-h is therefore equal to 1,000 B.t.u.

Find the 1,000 in column A and directly opposite in column B is the factor of evaporation. You can see that it is very close to 1.03.

The figures above 1,000 in column A, are seldom used. They are used sometimes in connection with feed water heater computations, however, and in order to make the chart more complete, I therefore included them also. Thus, where the difference in heat values might be 300 B.t.u., the factor of evaporation is immediately given as 0.31.

PROGRESS IN NEW EQUIPMENT

A Record of New and Improved Machinery and Accessories for the Machine, Pattern, Boiler and Blacksmith Shops, Planing Mill, Foundry and Power Plant

20-IN. DOUBLE BACK GEARED ENGINE LATHE

THE accompanying illustration shows the Atlas 20 in. engine lathe which is built by the Taylor Machine Co., Cleveland, O. It is equipped with double back gearing, quick change feed gear, and is built with 8, 10, and 12 ft. lengths of bed.

The head stock is offset from the centre of the bed to provide better distribution of the load on cross slide when engaged on heavy duty work. The spindle is made from a 50-point carbon steel forging, and runs in phosphor-bronze bearings with ring oilers. The three-step cone in conjunction with the double back gear gives nine spindle speeds. Front spindle bearing is 3½ x 6½ in. and the rear bearing 2¾ x 5¾ in. The total length of spindle is 36¾ in. and steel-bronze thrust bearing is fitted.

Heavy double-wall cross-girts are spaced two feet apart in the bed, giving ample stiffness. Two carriage-ways are provided on the bed, the front way being extra large. Owing to the use of a 20 per cent. steel mixture in the ways, the wear is confined to the carriage, thus avoiding loss of accuracy or alignment in the lathe bed.

The carriage vee is 2¼ in. wide, while the bridge is of unusual depth; the cross slide has a width of 9 in. The apron is a one-piece casting, with all bearings integral, and is pinned and bolted to the carriage. The lead screw is 1½ in. dia. x 4-pitch thread, and is made of 40-point carbon steel. The tailstock is of approv-

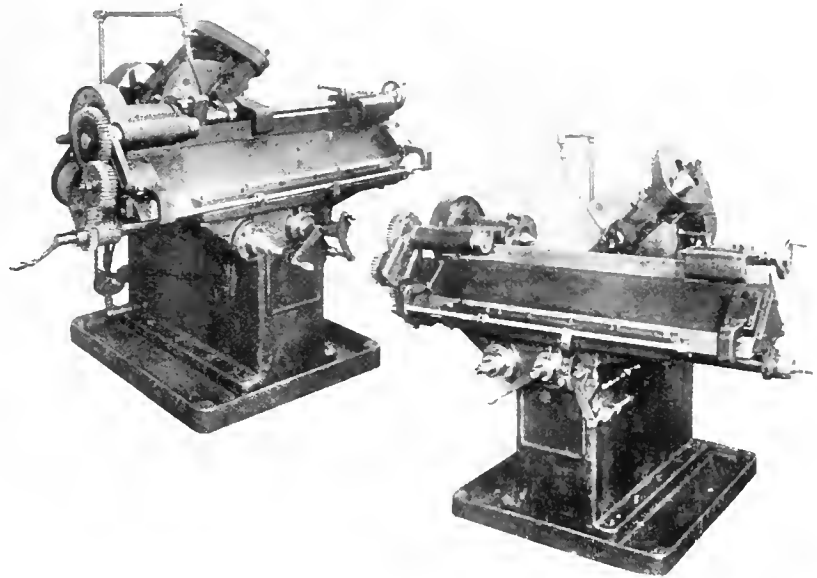

HEAVY DUTY MILLING MACHINE, TRAVELLING TABLE TYPE.

The feed gear box provides changes for 2 to 24 thds. per in., including metric threads up to 10 mm. pitch. The weight of this lathe with 10 ft. bed is 3,605 lbs.

gear mounted on the cutter arbor, a large proportion of the work done by machines of this type being such that it is possible to use a driving gear of much larger diameter than the cutter, thus conducing to both durability of the cutter and smoothness of cut. Where necessary, a smaller gear can be used. The cutter arbor is hardened and ground, and runs in bronze bushings, a tapered bronze bushing supporting the arbor outside of the cutter.

HEAVY DUTY MILLING MACHINE

THE machine illustrated herewith has been developed by the Moline Tool Co., Moline, Ill., in order to facilitate the production of heavy spirals and worms used in their regular product. The machine

The lead screw is splined its entire length and is made much heavier than customary to avoid any torsional deflection. Change gears are 6 pitch and wide face. Indexing is accomplished by a plunger dropping into an index plate set into the back of the main spindle driving gear.

Work up to 8 in. dia. x 30 in. long, can be performed; the spindle is bored 3.916 in. Work can either be held in centres, or a collet or 3-jawed chuck can be screwed on the spindle nose. A steady rest block is furnished to which bushings can be fitted for supporting the work on its large diameter or on the shaft as desired. The regular equipment includes pump and piping with a tank in the base, a 2-speed countershaft, one index plate having any number of holes desired, one bushing for the steady rest block and change gears. Weight approximately 5,000 pounds.

SHELL NOSE TIGHTENING MACHINE

PERSPPECTIVE view and detailed drawings illustrate a simple yet effective machine, largely in use, for tighten-



20-INCH DOUBLE BACK-GEARED ENGINE LATHE.

ed heavy duty type with double binding clamp on spindle, which is 3 in. dia., with 1 in. screw.

is of the traveling table type, the cutter only moving in and out of cut.

The cutter drive is through a large

ing the noses of shells, as manufactured by George Pireous, of Leeds Bridge Works, Leeds, England. As shown in Fig. 1, it follows the lines of a simple

on the ordinary lathe type of bed, so that it is applicable to any length of shell. The interesting feature is the method of securing the adapter for tighten-

meter, and an internal thread of 6 per in. Fig. 7 is a cast steel square head screw thread, cut to suit the internal thread of the plug, Fig. 5 is a mild steel clamp to grip the shell nose, and Fig. 8 a 3/4-in. diametrical hexagon steel screw. The operation of tightening the shell nose is as follows:—

The adapter is first screwed into the shell nose, which is then entered into the shell body, the square socket of the spindle being brought up to the square shank. The machine is next set in motion, and as the shell becomes tighter the nose plug revolves until the clamp grips the shell nose. When this is tightened home, the clutch on the machine automatically cuts the power off. In order to release the adapter the countershaft is reversed, the screw (Fig. 7) with coarse threads unscrews in the plug (Fig. 6), up to the shoulder of the set screw, which in turn unscrews. Thus in the distance between the shoulder of the set screw and the face of the plug the clamp is slack, and the whole arrangement can be unscrewed by hand.



WIRE NAIL MACHINES

A LINE of wire nail machines possessing novel mechanical and desirable operative features has been developed by Sleeper & Hartley, Inc., Worcester, Mass., as the result of several years activity in this line. Five sizes of these machines are built, handling wire from No. 17 to 3/8 in. dia. producing nails from 3/4 in. to 10 in. in length.

The illustrations show three of these machines, the No. 2 machine, which occupies a floor space of 19 x 42 in. and weighs 750 lbs., having a capacity 400-2 1/2 in. nails per minute, from No. 11 1/2 wire.

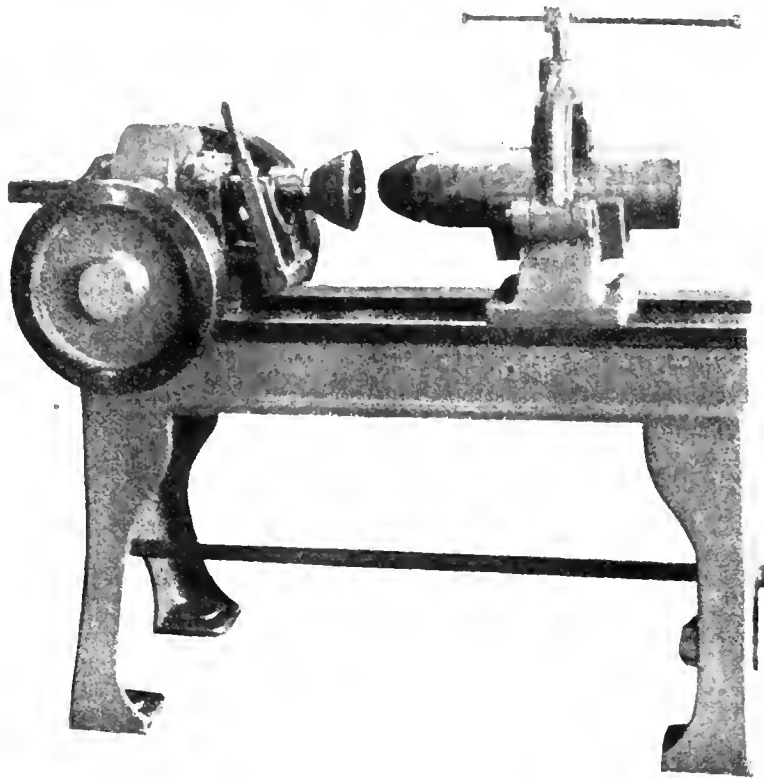

FIG. 1. SHELL NOSE TIGHTENING MACHINE.

lathe, the headstock spindle being driven (Figs. 2 and 3) by worm and worm wheel mounted on a cross-shaft, on one end of which is the flywheel and on the other the pulley, secured by a clutch with spring-pressed dog teeth to admit of slip should the speed exceed the predetermined rate. The countershaft belt pulley is arranged to drive in either direction.

ing the shell nose. This is shown in its assembled form in Fig. 4, the constituent units being illustrated in Figs. 5 to 8. The adapter is formed with a nose plug of cast steel (Fig. 6), with an external thread 14 per in. and 2 in. dia-

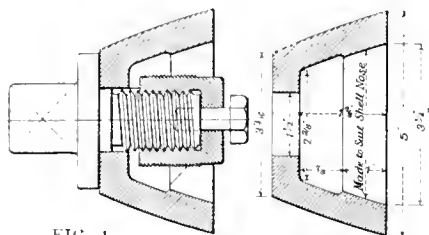

FIG. 4.

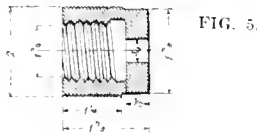

FIG. 5.

FIG. 6.

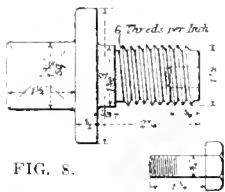

FIG. 8.

ASSEMBLY AND DETAIL OF ADAPTER FOR TIGHTENING SHELL NOSES.

The shell, it will be seen, is secured in a holder, arranged as desired, to accommodate any size of shell, which slides

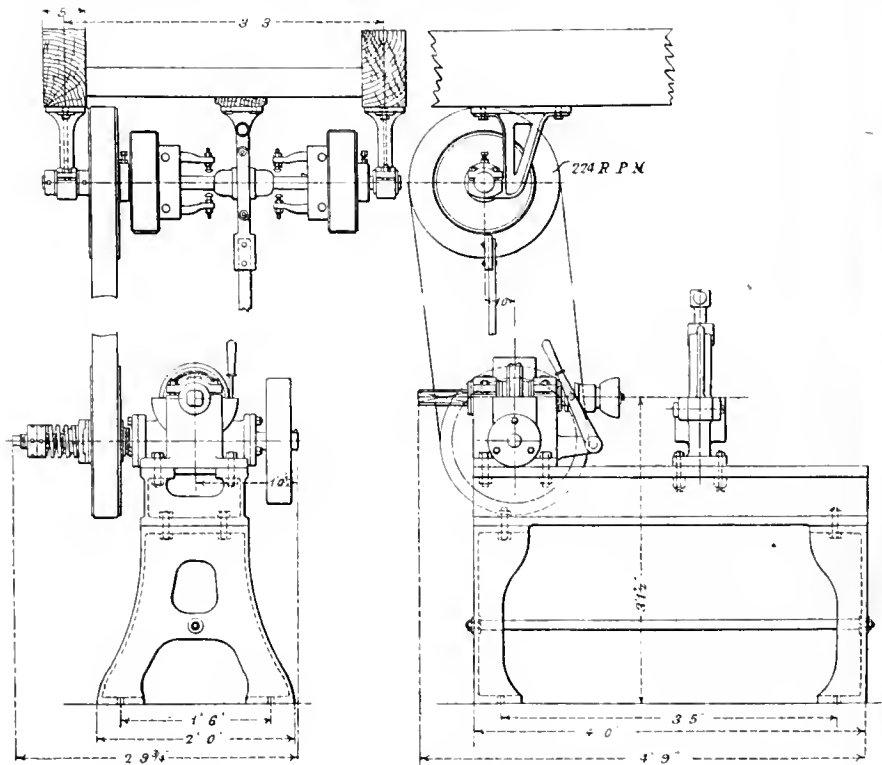

FIG. 2. INSTALLATION DETAIL OF SHELL NOSE TIGHTENING MACHINE.

FIG. 3.

The objects aimed at in designing these machines have been high output, quiet operation, compactness, wide distribution of stresses, and accessibility. All of the working members are mounted on the top of this frame, being so arranged and mounted that they can be lifted off and the machine stripped down in a few minutes. No rotating cams are used, the working motions being accomplished instead by means of toggle joints, actuated from a single crank shaft. All these moving members operate in mechanical balance, smoothly and easily, and with a practically noiseless result. The power is expended in making nails—not noise—and the consequent wear and tear upon the machine is enormously reduced.

The pointing and heading operations have been separated, the heating effects upon the dies being thereby greatly reduced, and the working stresses much more widely distributed. This is effected by means of an intermittently operated carrier wheel (interposed between the pointing and the heading position, and provided with a series of holding jaws) which takes the pointed blank from the pointing dies, and carries it through an angle of 180 degrees into the heading position where it is gripped by the heading dies and headed. The finished nail is still held by the carrier wheel jaws until it reaches a point about 90 degrees further on, when it is automatically released and dropped.

In operation the wire is taken from the coil, and fed through the straightener rolls mounted on the feed slide. This feed slide is operated through an adjustable connection from a crank, and in the larger machines is provided with a quick return motion. A single revolution of the machine feeds a blank, cuts it off (at the same time pointing the incoming wire end) heads a previously cut-off blank on the opposite side of the carrier wheel, and moves the carrier wheel through a partial revolution, thereby releasing a previously headed nail.

A very notable feature of the design is the accessibility of the pointing and

heading dies, any one of which may be lifted off in a few seconds for examination.

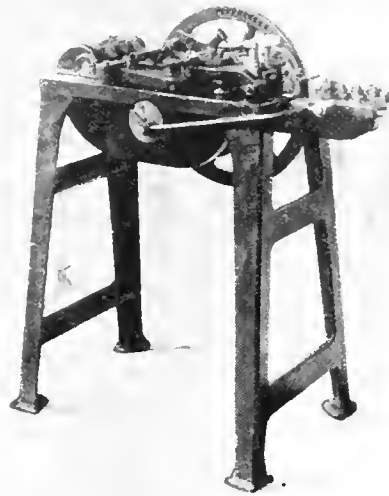

NO. 1 NAIL-MAKING MACHINE.

UNUSUAL INVENTOR AND HIS WORK

By D. A. H.

OUT in Los Angeles is an inventor whose story is the same as many another in most respects — little money to begin with, years of unceasing toil, etc.—but differs sharply in two other respects — his models, though crude, have every one been put to work and have paid for themselves and the patents covering them. The inventor is C. M. Mead and his improvements are widely known in the printing trade though until the recent formation of a corporation to manufacture the machines, they have not been on the market.

Beginning with a small rotary press, he improved it and developed it until it had a self-feeding arrangement and could print from a roll and could print several different "jobs" at one time. Further developments were, to obtain remarkably high speed, to produce the finest kind of multicolor work at

high speeds, to fold and count and wrap. All of these things are being done and have been for years, but Mead's inventions combine many of them in one machine along with other little labor-saving devices, so that a great saving in production cost is possible, mainly through the handling now done from machine to machine.

To other inventors, Mr. Mead's faculty for making his models pay for themselves is most remarkable. Every inventor knows how much even one patent costs, of the expense of experimental work and materials, of the frailty of models, how ideas have to be rejected before they can be put into commercial form. Mead did printing on his first small press, he went out and solicited work for all his presses as they were perfected. Thus he had an income at all times, and what is more, he had the chance to try out his machines under practical conditions—to spend unlimited time in the study of the problems arising from every day hard work. His work was all done in sheds at the rear of his home and his models were built of odds and ends—scrap iron, wood, wire, bicycle parts, structural steel—things he could buy cheaply.



SPECIAL SHELL MACHINES

(Continued from page 559)

design of this nut makes it very easy to effect repairs, when the nut or screw become badly worn. When power feed is required, the handle F is moved upwards, the shaft G revolved through a portion of a revolution, and the crank on the back end draws the link H, and also the lever I, upwards, thus raising the worm J and bringing it into mesh with the worm gear K, which is keyed to the end of the cross feed screw E. The feed can be automatically disengaged at any desired point by the adjustment of the collar L on the shaft G. A stop M, fixed to the front tool slide comes in contact with this collar and forces the rod and levers over a sufficient distance to allow the worm to drop from a working position; when the tools are withdrawn by turning the hand wheel, the reaction of the spring O on the collar N brings the operating levers back to their initial position in readiness for the next cut.

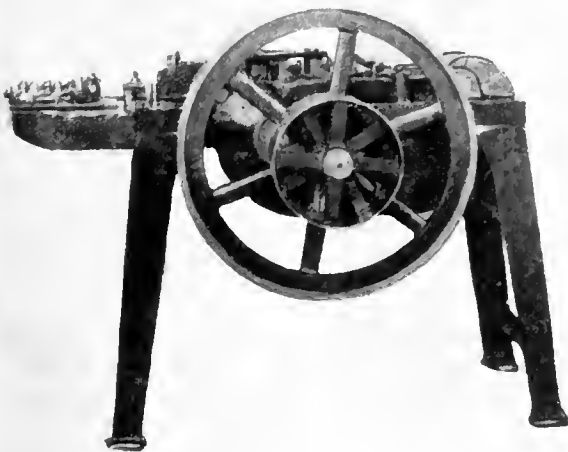

NO. 2 NAIL-MAKING MACHINE.

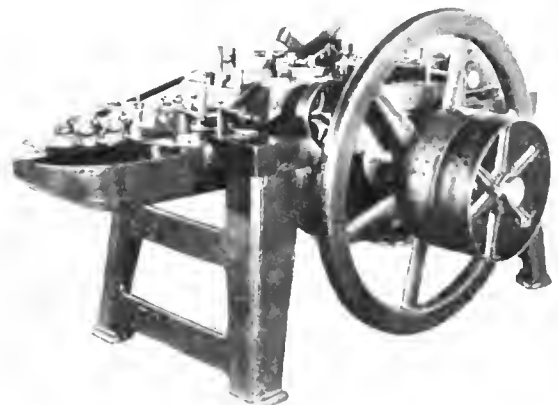

NO. 1 NAIL-MAKING MACHINE.

The MacLean Publishing Company

LIMITED

(ESTABLISHED 1888)

JOHN BAYNE MACLEAN - - - - - President
H. T. HUNTER - - - - - Vice-President
H. V. TYRRELL - - - - - General Manager

PUBLISHERS OF

CANADIAN MACHINERY AND MANUFACTURING NEWS

A weekly newspaper devoted to the machinery and manufacturing interests.

PETER BAIN, M.E., Editor. B. G. NEWTON, Manager.
Associate Editors
A. G. WEBSTER J. M. WILSON J. H. RODGERS

Office of Publication, 143-153 University Avenue, Toronto, Ont.

Vol. XVII. MAY 31, 1917 No. 22

EMERGENCY AND PERMANENT VALUES OF WOOD AND STEEL SHIPBUILDING INDUSTRIES

IT is of peculiar interest to note that the thousand wood vessel programme of the United States Government, involving the completion of that number of 3000-ton craft in eighteen months' time, has been passed up, in other words, investigation of the available resources has demonstrated the futility of the enterprise. Major-General Goethals, director of ship construction for the United States Government, speaking at the recent dinner of the American Iron and Steel Institute, pricked the wood-ship-in-quantity bubble by remarking that "when we consider that the birds are now meeting in the trees that were to go into these ships, and that the latter must have a speed of not less than 10½ knots if they were to escape being submarined, the proposition was hopeless."

Inasmuch, however, "as every little helps" so far as "bottoms" are concerned for the meantime overseas transportation of food and army supplies, the contribution of as many wood ships as material resources and plant capacity combined can put promptly into commission is in no sense to be discouraged, at the same time, it should be fully realized that, as a permanent national asset, wood schooner construction will at best have only a sentimental value. Even the steel sailing ship or barque has practically disappeared from ocean service, its displacement by the tramp steamer being quite as complete as was that of the wood schooner when steel became the material of construction. The best and most substantial contribution that Canada and the United States can make towards the rehabilitation of the world's ocean-carrying service is that of steel built, steam propelled ships, and in their plans and arrangements to that end they will be establishing and consolidating a coterie of industries within an industry of the highest possible value, making not only for permanence, but national progress in and development of a multiplicity of arts, crafts and specialized manufactures.

In advising the American Iron and Steel Institute of the results of his investigation concerning wood shipbuilding, Major-General Goethals took occasion to point out that, as ships were urgently required, and must of necessity be of steel, the co-operation of iron and steel manufacturers was a sine qua non of production. As a result of the plea made, the resources of the United States iron

and steel industries are to be mobilized and placed at his disposal, and as an earnest of successfully carrying through such an undertaking, an administrative committee has been appointed, its personnel including such steel industry giants as Judge Elbert H. Gary, James A. Farrell, Charles M. Schwab, etc.

We in Canada don't seem to be at all awake to the immense importance attaching to steel shipbuilding, else long ere this tangible evidence would have been forthcoming of both steel plant and ship plant enterprise on our ocean highways and ocean shores. That hesitancy has been displayed in embarking on a wood shipbuilding programme doubtless admits of considerable justification because of its certain fleeting existence; why, however, an equal hesitancy should be shown towards broadening the scope of present, and the initiation of new lines of industrial endeavor whose outcome would be the creation and upbuilding of a Canadian built, equipped, manned and owned, ocean as well as lake fleet, of freight carriers of world competitive importance, there appears no good and sufficient reason.

The dual programme of wood and steel shipbuilding may have obscured the issue and complicated the situation somewhat, however, the wood construction feature as disposed of in the United States, may as likely as not allow more real concentration on that of steel, and lead even now to some worth-while developments in the latter. It is believed that the Algoma Steel Corporation, Sault Ste. Marie, Ont., have some comprehensive plans in process which will stimulate very materially our steel shipbuilding.



PROPOSED SECRET SESSION OF BRITISH ENGINEERS

A PROPOS of the recent registration of Canadian engineers, at least those constituting the membership of our various Technical Societies and Associations, with a view to their services being made available to the Government either in consulting, administrative, or research capacities, a unique proposal has been made to secure a secret session of Old Country engineers, at which a representative of the British Admiralty would explain the means being taken to combat the submarine menace, and detail as fully and clearly as possible such problems connected therewith as yet remain unsolved. While it is realized that the Imperial Government can command, and has at its service, no end of what are believed to constitute the best scientific brains available, it is more than probable that much brain wealth is outside the fold. Our British contemporary, "The Engineer," very aptly remarks when discussing the subject that "useful inventions frequently spring from quite unexpected quarters, and that if the brains now officially at work have failed to solve the submarine problem, it is time others were tried, and high time that new fields of thought were explored."

The secret session proposed would be organized and managed by some such body as the Institution of Civil Engineers, the individual members to include men drawn from the country's principal engineering and shipbuilding establishments to the number of say three or four hundred, and of whose ability and integrity there could be no doubt. Secret sessions of the British House of Commons have been held on several occasions with a view ostensibly to stimulate moral support in the successful prosecution of the war, and such a procedure is of course quite valuable. A secret session of engineers such as now suggested would be double-barrelled in result; for not only would the strictly moral feature be stimulated, but some real genius would undoubtedly be disclosed and, in its train, a means or mechanism, or both, created and perfected which would effectually rid the seas of both the cold-blooded Hun and his submarine craft.

INDUSTRIAL NOTABILITIES

H. J. WADDIE, president and general manager, Canadian Drawn Steel Co., Ltd., Hamilton, Ont., was born in Edinburgh, Scotland, Oct. 19, 1869, son of John Waddie, shipbroker and Agnes (Sinclair) Waddie.

On the completion of his education, received at Royal High School, Edinburgh, and University College, Dundee, he was apprentice to Hawthornes, Ltd., engineers and shipbuilders, Leith, 1887-92; assistant manager, Dennystown Forge, Dumbarton, 1895; manager, Jarrow Forge & Engineering Co., Jarrow-on-Tyne, 1896; assistant managing director, Perfect Tube Co., Birmingham, 1897; general manager, Mannesmann Tube Co., Swansea, 1898-1901. In 1901 Mr. Waddie came to Canada as manager of the Algoma Tube Co., Sault Ste.

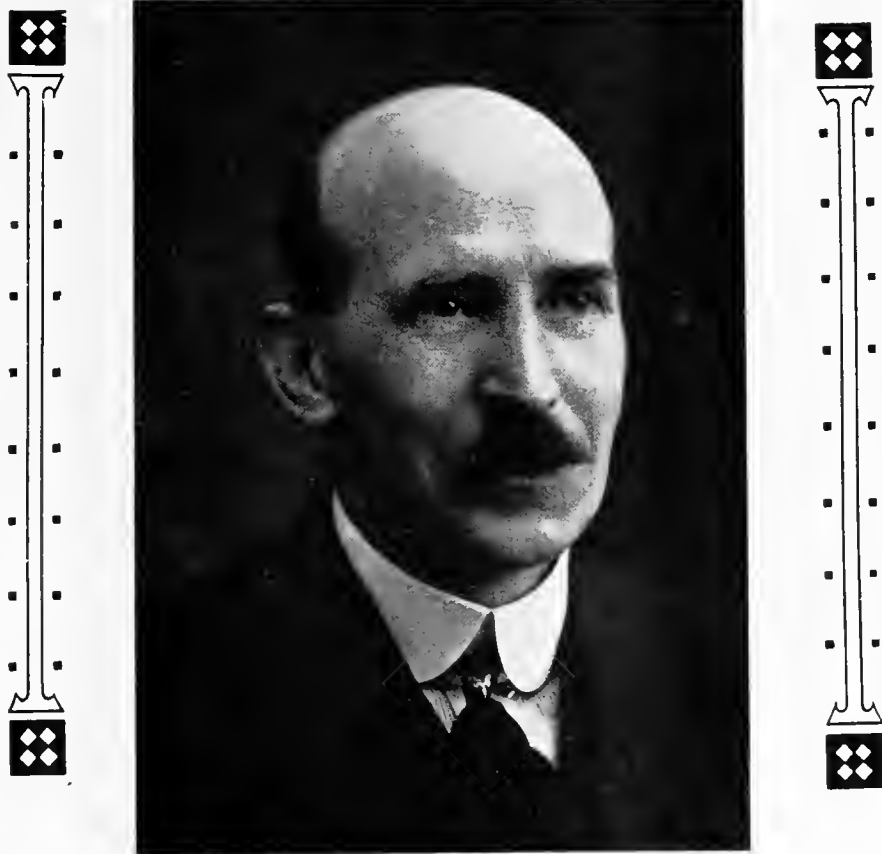

H. J. WADDIE

Marie, which project failed to materialize. In 1904 he organized the present company.

Mr. Waddie's civic, social, and administrative activities have been very extended.—Chairman, Hamilton Centennial Industrial Exposition, 1913; chairman, Hamilton Branch, Canadian Manufacturers' Assoc., 1913-15; fellow of the Royal Colonial Institute; member, Toronto Exhibition Assoc.; director, Export Assoc. of Canada; chairman, Manufacturing Committee, Hamilton Recruiting League; chairman, Employment Bureau for Returned Soldiers; governor, Art Gallery of Hamilton; chairman, Committee British Sailors' Relief Fund.

He married Amy White, daughter of Col. J. C. White, Landore, South Wales, 1900; (deceased Apr. 30, 1916).

Clubs are:—Hamilton; Thistle; Burlington Country. Societies: A. F. & A. M. Recreations: Golf, Yachting, Angling, Travel. In politics Mr. Waddie is Conservative, and in religion, Presbyterian.

Mr. Waddie's residence is 50 Markland St., Hamilton, Ont.

Photo, Courtesy British and Colonial Press.

SELECTED MARKET QUOTATIONS

Being a record of prices current on raw and finished material entering into the manufacture of mechanical and general engineering products.

PIG IRON.

Grey forge, Pittsburgh.....	\$40 95
Lake Superior, charcoal, Chicago.....	50 25
Standard low phos., Philadelphia.....	75 00
Bessemer, Pittsburgh.....	45 95
Basic, Valley furnace.....	42 00
Montreal Toronto	
Middlesboro, No. 3.....	
Cleveland, No. 3.....	
Clarence, No. 3.....	
Hamilton.....	
Victoria.....	50 00

2½ in.....	42 71	52 94
3 in.....	55 85	69 23
3½ in.....	68 08	86 02
4 in.....	80 66	101 90
4½ in.....	93 98	118 70
5 in.....	109 50	138 40
6 in.....	142 10	179 50
7 in.....	185 60	232 05
8 L in.....	195 00	243 75
8 in.....	224 60	280 80
9 in.....	269 10	336 38
10 L in.....	249 60	312 00
10 in.....	321 40	401 70

Prices—Ontario, Quebec and Maritime Provinces.

FINISHED IRON AND STEEL.

Per lb. to Large Buyers.....	Cents
Iron bars, base, Toronto.....	5 00
Steel bars, base, Toronto.....	5 25
Steel bars, 2 in. to 4 in. base.....	6 00
Steel bars, 4 in. and larger base.....	7 00
iron bars, base, Montreal.....	4 75
Steel bars, base, Montreal.....	5 00
Reinforcing bars, base.....	5 25
Steel hoops.....	7 00
Bessemer rails, heavy, at mill.....	38 00
Steel bars, Pittsburgh.....	4 00
Tank plates, Pittsburgh.....	6 50
Beams and angles, Pittsburgh.....	4 00
Steel hoops, Pittsburgh.....	4 25

F.O.B. Toronto Warehouse.

Steel bars, base.....	5 25
Small shapes.....	5 50

F.O.B. Chicago Warehouse

Steel bars.....	4 50
Bars, 2 in. and up.....	4 65
Structural shapes.....	5 00
Plates.....	7 00

FREIGHT RATES.

Pittsburgh to Following Ports.....	Per 100 lbs.
	C.L. L.C.I.
Montreal.....	23.1 31.5
St. John, N.B.....	35.1 45.5
Halifax.....	35.1 45.5
Toronto.....	18.9 22.1
Guelph.....	18.9 22.1
London.....	18.9 22.1
Windsor.....	18.9 22.1
Winnipeg.....	64.9 85.1

METALS.

	Montreal	Toronto
Lake copper.....	\$38 50	\$37 00
Electro copper.....	38 50	37 00
Castings, copper.....	37 50	36 00
Fin.....	62 50	68 00
Spelter.....	13 50	12 00
Lead.....	13 50	14 00
Antimony.....	27 00	30 00
Aluminum.....	70 00	68 00

Prices per 100 lbs.

PLATES.

	Montreal	Toronto
Plates, ¼ to ½.....	\$9 00	\$9 00
Heads.....	9 30	9 10
Tank plates, 3-16 in.....	9 10	9 10

WROUGHT PIPE.

	Black Galvanized	
	Standard Buttwd.	
Size.....	Per 100 feet	
1 in.....	11 73	14 88
1½ in.....	15 87	20 13
2 in.....	18 98	24 06
2½ in.....	25 53	32 38
3 in.....	40 95	51 77
3½ in.....	53 55	67 70
4 in.....	66 24	83 26
4½ in.....	78 48	98 65
5 in.....	\$ 4 50	\$ 6 00
5½ in.....	4 96	7 00
6 in.....	4 96	7 00
6½ in.....	6 29	7 86
7 in.....	7 94	10 06
Standard Lapwd.		
2 in.....	28 49	34 97

MILLED PRODUCTS.

Set screws.....	35
Sq. & Hex. Head Cap Screws.....	30
Rd. & Fil Head Cap Screws.....	10
Flat ½ But. Hd. Cap Screws.....	10
plus.....	10
Fin. & Semi-fin. nuts up to 1 in.....	25
Fin. and semi-fin. nuts, over 1 in., up to 1½ in.....	30
Fin. and semi-fin. nuts, over 1½ in., up to 2 in.....	10
Studs.....	20
Taper pins.....	40
Coupling bolts, plus.....	10
Planer head bolts, without filet, list plus.....	10
Planer head bolts, with filet, list plus 10 and.....	10
Planer head bolt nuts, same as finished nuts.....	
Planer bolt washers.....	net
Hollow set screws.....	list plus 20
Collar screws.....	list plus 30, 10
Thumb screws.....	20
Thumb nuts.....	65
Patc bolts.....	add 40, 10
Cold pressed nuts to 1½ in.....	add \$4.50
Cold pressed nuts over 1½ in.....	add \$7.00

Sleeves.....	40
Taper pin reamers.....	20
Drills and countersinks.....	list plus 30
Bridge reamers.....	45
Centre reamers.....	10
Chucking reamers.....	10
Hand reamers.....	15

COLD ROLLED SHAFTING.

At mill.....	list plus 40%
At warehouse.....	list plus 50%
Discounts off new list. Warehouse price at Montreal and Toronto.	

IRON PIPE FITTINGS.

Canadian malleable, A, add 10%; B and C, 10%; cast iron, 35%; standard bushings, 50%; headers, 60; flanged unions, 40; malleable bushings, 50; nipples, 55; malleable flpped unions, 50.

SHEETS.

	Montreal	Toronto
Sheets, Black, No. 28.....	\$7 75	\$8 60
Sheets, Black, No. 10.....	7 50	8 15
Canada plates, dull, 52 sheets.....		8 50
Canada plates, all bright.....		9 50
Apollo brand, 10¼ oz. galvanized.....	7 25	7 26
Queen's Head, 28 B. W.G.....	7 75	7 75
Fleur-de-Lis, 28 B.W. G.....	7 45	7 35
Garbal's Rest, No. 28.....	8 25	7 50
Colborne Crown, No. 28.....	8 00	6 75
Premier, No. 28 U.S.....	8 30	9 70
Premier, 10¼ oz.....	8 60	10 00

BILLETS.

	Per gross ton
Bessemer billets.....	\$ 90 00
Open-hearth billets.....	90 00
O.H. sheet bars.....	90 00
Forging billets.....	110 00
Wire rods.....	85 00
F.o.b. Pittsburgh.	

NAILS AND SPIKES.

Wire nails.....	5 00	4 95
Cut nails.....	5 00	5 00
Miscellaneous wire nails.....	60%	
Pressed spikes, ½ diam., 100 lbs.....	5 90	

MISCELLANEOUS.

Solder, strictly.....	0 38
Solder, guaranteed.....	0 41
Babbitt metals.....	16 to 65
Soldering coppers, lb.....	0 53
Putty, 100-lb. drum.....	4 35
White lead, pure, cwt.....	17 50
Red dry lead, 100-lb. kegs, per cwt.....	13 87
Glue, English.....	0 38
Tarred slaters' paper, roll.....	0 95
Gasoline, per gal., bulk.....	0 31½
Benzine, per gal., bulk.....	0 30½
Pure turpentine, single bbls., gal.....	0 72
Linseed oil, raw, single, bbls.....	1 40
Linseed oil, boiled, single bbls.....	1 43
Plaster of Paris, per bbl.....	2 50
Plumbers' oakum, per cwt.....	9 00
Packing, square braided.....	0 32
Packing, No. 1 Italian.....	0 38
Packing, No. 2 Italian.....	0 30
Lead wool, per lb.....	0 15
Pure Manila rope.....	0 33½
Transmission rope, Manila.....	0 43½
Drilling cables, Manila.....	0 38½

POLISHED DRILL ROD.

Discount off list, Montreal and Toronto.....	25%
--	-----

CARBON DRILLS AND REAMERS.

	Per Cent.
S.S. drills, wire sizes up to 52 40	
S.S. drills, wire sizes, No. 53 to 80.....	25
Standard drills to 1½ in.....	40
Standard drills, over 1½ in.....	15
3-fluted drills, plus.....	10
Jobbers' and letter sizes.....	40
Bit stock.....	40
Ratcheet drills.....	15
S.S. drills for wood.....	40
Wood boring brace drills.....	25
Electricians' bits.....	30
Sockets.....	40

ELECTRIC WELD COIL CHAIN B.B.

¼ in.....	\$9 75
5-16 in.....	9 40
¾ in.....	8 65
7-16 in.....	7 45
1½ in.....	7 25
9-16 in.....	7 25
¾ in.....	7 15
¾ in.....	7 05
¾ in.....	7 00
1 inch.....	6 90
Extra for B.B. Chain.....	1 20
Extra for B.B.E. Chain.....	1 80

Prices per 100 lbs.

FILES AND RASPS.

	Per Cent.
Great Western, American.....	55
Kearney & Foot, Arcade.....	55
J. Barton Smith, Eagle.....	55
McClelland, Globe.....	55
Whitman & Barnes.....	55
Black Diamond.....	45
Delta Files.....	40, 5
Nicholson.....	45
Globe.....	55
Vulcan.....	55
Disston.....	55

COAL AND COKE.

Solvay Foundry Coke.....	\$10 90
Cornelsville Foundry Coke.....	
Steam Lump Coal.....	8 50
Best Slack.....	8 05
Net ton f.o.b. Toronto	

BOILER TUBES.		
Size.	Seamless	Lap-welded
1 in.	\$30 00
1 1/4 in.	33 00
1 1/2 in.	35 00	31 00
1 3/4 in.	34 00	30 60
2 1/4 in.	40 00	35 00
2 in.	38 00	30 00
2 1/2 in.	46 00	36 00
3 in.	52 00	42 00
3 1/4 in.	48 00
3 1/2 in.	62 00	52 00
4 in.	70 00	65 00

Prices per 100 feet, Montreal and Toronto.

OILS AND COMPOUNDS.	
Castor oil, per lb. 45
Royalite, per gal., bulk 16
Palacine 19
Machine oil, per gal. 26 1/2
Black oil, per gal. 13
Cylinder oil, Capital 45 1/2
Cylinder oil, Acme 36 1/2
Standard cutting compound, per lb. 6 15
Lard oil, per gal. 1 45
Union thread cutting oil antiseptic 68
Acme cutting oil, antiseptic 37 1/2
Imperial quenching oil 39 1/2
Petroleum fuel oil 11

BELTING—NO. 1 OAK TANNED.	
Extra heavy, single and double 30-5%
Standard 40%
Cut leather lacing, No. 1 1 50
Leather in sides 1 35

TAPES.	
Chesterman Metallic, 50 ft.	\$2 00
Lufkin Metallic, 603, 50 ft.	2 00
Admiral Steel Tape, 50 ft.	2 75
Admiral Steel Tape, 100 ft.	4 45
Major Jun. Steel Tape, 50 ft.	3 50
Rival Steel Tape, 50 ft.	2 75
Rival Steel Tape, 100 ft.	4 45
Reliable Jun. Steel Tape, 50 ft.	3 50

WASTE.	
White	Cents per lb.
XXX Extra 20
Peerless 20
Grand 19
Superior 19
X L C R 18
Atlas 18
X Empire 18
Ideal 17
X press 16

COLORED.	
Lion 14 1/2
Standard 13
No. 1 13
Popular 11 3/4
Keen 10 1/2

WOOL PACKING.	
Arrow 25
Axle 20
Anvil 15
Anchor 11

WASHED WIPERS.	
Select White 12
Mixed colored 10
Dark colored 09

This list subject to trade discount for quantity.

RUBBER BELTING.	
Standard 40%
Best grades 20%

ANODES.	
Nickel 50 to 54
Cobalt 1.75 to 2.00
Copper44 to .46
Tin49 to .56
Zinc23 to .25

COPPER SHEETS.	
Montreal Toronto	
Bars, 1/2 to 2 in.	55 00 53 00
Plain sheets, 14 oz.
14x28 in., 14x60 in.	55 00 53 50
Copper sheet, tinned, 14x60, 14 oz.	60 00 54 25
Copper sheet, plain, 14x60 base.	64 00 60 00
Braziers' in sheets, 6x4 base	55 00 52 00

BRASS.	
Brass rods, base 1/2 in to 1 in rd.	0 55
Brass sheets, 8 in. wide, 20 oz.	0 60
Brass tubing, seamless.	0 57
Copper tubing, seamless.	0 58

PLATING SUPPLIES.	
Polishing wheels, felt.	2 50
Polishing wheels, bull-neck	1 35
Emery in kegs, American	06
can	04
Pumice, ground	04
Emery glue	15 to 20
Tripoli composition	04 to 06
Crocus composition	07 to 08
Emery composition	08 to 09
Rouge, silver	35 to 50
Rouge, powder	30 to 35

LEAD SHEETS.	
Montreal Toronto	
Sheets, 3 lbs. sq. ft.	\$17 00 \$17 00

Sheets, 3 1/2 lbs. sq. ft. 17 00	17 00
Sheets, 4 to 6 lbs. sq. ft. 16 50	16 50
Cut sheets, 1/2 per lb. extra		
Cut sheets to size, 1c per lb. extra.		

PLATING CHEMICALS.	
Acid, boracic \$ 15
Acid, hydrochloric 05
Acid, hydrofluoric 14 1/2
Acid, nitric 10
Acid, sulphuric 05
Ammonia, aqua 08
Ammonium carbonate 15
Ammonium chloride 11
Ammonium hydrosulphuret 40
Ammonium sulphate 07
Arsenic, white 12
Copper, carbonate, anhyd. 35
Copper, sulphate 17
Cobalt sulphate 50
Iron perchloride 20
Lead acetate 16
Nickel ammonium sulphate 12
Nickel carbonate 35
Nickel sulphate 15
Potassium carbonate 75
Potassium sulphide (substituted) 20
Silver chloride (per oz.) 65
Silver nitrate (per oz.) 55
Sodium bisulphite 10
Sodium carbonate crystals 05
Sodium cyanide, 127-130% 41
Sodium hydrate 04
Sodium hyposulphite, per 100 lbs. 5.00
Sodium phosphate 14
Tin chlorite 60
Zinc chloride 60
Zinc sulphate 09

Prices Per Lb. Unless Otherwise Stated.

The General Market Condition and Tendency

THE steady advance in prices of steel products continues and it is evident that the market is still far from the turning point. The insistent demand for steel and congested conditions at the mills indicate a continuance of the present upward movement which is further strengthened by increasingly heavy demand of the American Government. The position of the private consumer is steadily becoming more acute, owing to the urgent demand for steel for war purposes. Not only is material difficult to obtain, but prices are so high as to interfere with industrial enterprises. The price changes this week include 25c per 100 lbs., on iron and steel bars and small shapes. Iron bars are now 5c, steel bars 5.25c, and shapes 5.50c. Steel plates have advanced \$1 and are now quoted at a nominal price of 9c. Black, blue annealed and galvanized sheets have also advanced, and still higher prices are looked for. Domestic foundry pig-iron is unchanged and the market is very firm. Producers are practically sold up for this year and have considerable tonnage booked for the first half of 1918. The scrap metal market is firmer and higher prices have to be noted on copper, brass, machinery cast iron and malleable scrap. Consumers are buying scrap more freely to replenish depleted stocks, thus strengthening the market. The non-ferrous metal markets are firmer, but prices are unchanged with the exception of lead, which has advanced. No marked improvement in the metal markets is expected until the American Government's requirements are known both as to quantity and prices. A good demand for machine shop supplies continues with indications of higher prices. The machine tool business is quiet and featureless.

Montreal, Que., May 28, 1917 — The industrial situation is in a measure unchanged from last week. The difficulty of securing reliable information relative to the U.S. war policy has made producers rather reluctant about booking business for definite delivery. Canadian manu-

facturers are affected to the extent that much difficulty is being experienced in the obtaining of raw materials and this circumstance is expected to become worse before it is better. Recent developments in the United States point to a re-adjustment of market conditions, more particu-

larly in connection with copper which was recently brought into the limelight before the House of Representatives.

Pig Iron

The situation in pig iron remains unchanged, with the exception that prices on American iron are still advancing. The placing of orders for future delivery is not so pronounced as a few weeks back, but these lulls are generally a feature of such conditions as prevail at the present time. The supply of pig is still far below requirements of consumers, with the possibility that the situation may become still worse as the summer advances. The Canadian outlook is much the same, dealers looking forward to a stronger market than that now nominally quoted at \$50 per ton.

Steel

The steel situation continues to reflect the increasing difficulties that are contingent on supplying unprecedented military, naval and domestic requirements. The rapid advance in prices does not appear to have had any effect upon the general demand; on the contrary, the consumption of raw material has gradually increased to such proportions that even with every possible facility working to highest producing capacity, the supply is inadequate to the needs of the trade. In many instances domestic business has had to stand aside in order that war necessities might receive the full attention of steel producers, but where domestic requirements could be handled, the high cost has only been a secondary consideration to that of securing material. However, both the Allies and the United States are fully impressed with the urgent neces-

sity of sacrificing every non-essential need for the more rapid fulfilment of those demands that are directly or indirectly connected with the war. With these conditions developing, it is more than likely that still higher prices will require to be paid by contractors who desire material for strictly domestic purposes. The actual needs of the American Government are still a matter of conjecture, but it is reasonably certain that these requirements will gradually increase as the policy of the authorities assumes more tangible form. An undisputed fact appears to be that the full capacity of plate mills will be required for the accomplishment of the shipbuilding programme which is at present the centre of interest of an interesting and complicated situation, not alone on this side of the Atlantic, but in all European countries. The loss of tonnage has been so enormous that its replacement is probably the most essential factor in the problem now facing the various governments, and every co-operation should be made between producers and the governments, to further the speedy output of as much ship plate material as will meet all requirements of the shipbuilding industry. However, it is conceded that the past three years' experience has not been taken as an example, but more as a lesson, from which the future programme can be successfully prepared. The demand for shell billets of the larger sizes is less in comparison with that of a few months back, but the consumption of the smaller sizes shows no falling off. The Pittsburgh price on wire rods has been advanced \$5 per ton, the quotation being now \$100 per ton. This is the price on the open market, and is likely the result of the placing of a Government order of 25,000 tons, although it has not been announced what price has been paid. Structural steel is quite active, particularly in the States, where considerable tonnage is required for the erection of necessary additions to meet the increasing requirements. The sheet situation shows no improvement, and prompt shipment is practically impossible; the little available being secured by certain customers on the payment of large premiums. The Pittsburgh quotation on blue annealed sheets has been advanced \$10 per ton, the base price being now 7½ cents per pound. Galvanized sheets are now quoted at \$9.70 per hundred, the latest advance being \$4 per ton. The situation in wrought iron pipe and boiler tubes is about the same, with the mills filled up for many months ahead. The market in wire products is expected to become stronger, following the recent advance in wire rods.

The situation in the Canadian market is much the same as last week, dealers holding to previous quotations, but with advances under consideration. Deliveries are becoming more uncertain owing to the developments in the United States.

Metals

The market in metals continues firm, but is influenced by the gradual development of war activities in the States, as uncertainty pervades the situation due to the fact that reliable information is not

available regarding the definite war policy of the Government. Sensational statements relative to the actual production costs of copper has opened up a situation that may result in a complete revision of price quotations on all metals and also other products. Copper is still firm but with an uncertain undertone. Tin is quiet but fairly steady. Spelter has a firm tone but continues quiet. Lead is exceptionally strong with outside metal higher. Antimony is weaker abroad but firm locally. Aluminum is steady and unchanged.

Copper.—Somewhat of a sensation was created at a recent meeting of the American House of Representatives when it was learned that a current report of one of the largest copper producing companies in the United States, contained a statement that copper could be put f.o.b. the cars at 5¼ cents per pound. If this statement is true or reasonably so, the early future condition in the copper situation may develop some very interesting features. It has been intimated that further purchases of Government copper would be made at or around 25 cents, but the developments of the past week may upset the plans of the producers in making a market on a basis of their own. If investigation should prove that the above statement has been based on fact, it might apply also to other industries and a general re-adjustment would not be unlikely. The New York market is firm at present, but an undertone of weakness seems to pervade the situation.

Local dealers report unchanged conditions with prices firm but showing a weaker tendency, being 38½ cents for lake and electro, and casting 37½ cents per pound.

Tin.—The market has taken on rather a dull tone, and this is apparently accounted for by the uncertainty that prevails regarding the issuing of permits for tin shipments from England, together with the possibility of loss in transit; the latter being a feature that tends to keep the market in somewhat of an unsettled state. Absence of activity is also due to lack of knowledge of what the attitude of the American Government will be, regarding the tax that is likely to be placed on tin in conjunction with other metals. With tin firm in London, the New York market shows a slight weakness, having declined ½ cent on the week, the current quotation being 65 cents per pound. The market here is unchanged, with prices steady at 62½ cents per pound.

Spelter.—With dullness featuring the present situation, the undertone of the market is comparatively strong, due to the fact that future positions are practically on the same level as spot metal. The whole situation is, however, influenced by the war arrangements, and until a definite programme is announced it is not expected that a sound market will prevail in this or any other metal. The quotation of 9½ cents per pound is ½ cent stronger than last week. In the local market an upward tendency is evident, but dealers continue to quote 13½ cents per pound.

Lead.—This metal appears to be the only one that is retaining its strong position without wavering, as in some re-

spects it is the one that will have the heaviest demands made upon it when the final decision as to requirements is made by the American Government. Should the demand for excessive quantities be made suddenly, the supply would be quite inadequate to meet the need and prices in consequence would again soar. The "Trust" price remains firm at 10 cents, but "Independents" are asking as high as 11½ cents, this being ¾ cent higher than last week. Lead is firm locally at 13½ cents per pound.

Antimony.—The quiet tone of the market has developed a weaker tendency with the situation generally disturbed by the slow developments in U.S. Government circles. New York is quoting the nominal figure of 25 cents, which is one cent lower than a week ago. Dealers here are still quoting 27 cents, but on a quiet market.

Machine Tools and Supplies

The past week has seen a slight increase in the demand for machine tools, generally for fall delivery. This activity is along the lines of ordinary standard equipment for domestic purpose. The requirements for shell manufacture have shown considerable falling off, more particularly as regards the heavier shells; none of the machines used for the latter purpose, however, are being placed openly on the market as further production of the larger shells may only be deferred. The United States situation is unchanged, the trade apparently awaiting the outcome of the Machine Tool Builders Convention being held in Cincinnati. The attitude taken by this assembly will likely have considerable bearing on the future condition of the industry, as every feature of the general abnormal situation will receive the most careful attention, with a view to reasonable adjustment to suit the inevitable developments that are certain to follow an indefinite period of active participation in the war.

Scrap

The market is firm but uncertain and dealers are content to quote the prices that have prevailed for the past week. Dealers here report fair business, but handling of material is handicapped by lack of shipping facilities.

Toronto, Ont., May 29.—Manufacturers are feeling more than ever the shortage and high cost of raw materials while it is likely that a scarcity of labor will become more pronounced if conscription is enforced. As this is practically assured measures will have to be adopted to relieve the situation. In regard to the shortage of raw materials there appears little possibility of any betterment in the outlook. This is particularly true of iron and steel, as the demand for these materials is increasing out of proportion to the supply. The congestion at the mills is getting more acute with no prospects of production overtaking the demand. In spite of all these handicaps, trade was perhaps never better as shown in company reports and Government returns.

Steel

War requirements dominate the steel market to such an extent that every other

consideration is relegated to the background and private consumers are in a worse position than at any time since the beginning of hostilities. The congested condition of the mills in the States is getting worse and the shortage of steel is thus becoming more acute. The constantly increasing demands of the American Government are making it increasingly difficult for private consumers of iron and steel to cover their requirements. Some of the larger makers of finished products have practically had to withdraw from the market owing to the fact that Government demands have to be met first. There is no let-up in the demand for steel products. Some concerns are said to be refusing business because of the crowded condition of the mills. Premiums are being paid for good deliveries and several steel concerns who can take contracts for comparatively nearby deliveries are receiving fancy prices from consumers who are in urgent need of material. Some consumers are sending in orders for steel without any reference to price. So urgent is the need that price is a secondary consideration. Warehouse stocks are also low, being in some cases depleted of certain sizes. Dealers are substituting sizes in order to meet customers' requirements. The situation is such that higher prices on steel products are inevitable. This week prices of iron and steel bars and small shapes have advanced 25c. per 100 lbs.; these materials being now quoted as follows: Iron bars 5c., steel bars 5.25c., and shapes 5.50c. base. Steel plates have also advanced, but quotations are practically nominal. Plates, 1/4-in. and larger, are now 9c., heads and tank plates, 9.10c. base. The situation as regards the supply of plates is getting tighter right along and prices continue to advance rapidly. Canadian shipbuilding interests who are in the market for plates are having the greatest difficulty in obtaining material even at the fancy prices now current. It is understood that approximately 75 per cent. of the plate mill capacity in the States is being used for shipbuilding. Wrought pipe is very firm at the last advance and higher prices are likely. Prices of boiler tubes continue very firm and heavy premiums are being paid to any makers of iron or steel tubes who can ship out fairly promptly.

Prices of black and galvanized sheets have again advanced and the market is very firm. Black sheets are now quoted at \$8.60 for No. 20 gauge and blue annealed \$8.15 for No. 10 gauge. Galvanized sheets have advanced \$1. Premier No. 28 being quoted at \$9.70 and 10 3/4 oz. at \$10. Canada plates bright are now \$9.50 and dull \$8.50. One reason for the advance in sheets is the high cost of sheet bars which have recently jumped up to \$90 Pittsburgh. There is also a great scarcity of sheets as the American Government have taken over considerable tonnage. It is not unlikely that black sheets will be selling at \$10 before the end of the year.

Arrangements are being made for the united buying of steel for the American and Allied Governments. By co-ordination in this way it is hoped that all avail-

able resources will be utilized to the best advantage. No prices have been as yet announced under the new arrangement, but it is believed that nearer current prices will be paid that were originally fixed. Prices continue to advance and it is evident that the market is still far from the turning point and that still higher prices may be expected. The chief problem for the steel mills to solve is the question of satisfying the enormous demands now being made upon them. The unfilled tonnage is piling up every day with no apparent possibility of overtaking the business. The shortage of steel is so great that consumers cannot obtain the required material and private enterprise is being interfered with. The principal price advances this week include semi-finished material. Bessemer and O.-H. billets and O. H. sheet bars are now quoted at \$90 and forging billets \$110 Pittsburgh.

Pig Iron

A leading domestic producer is practically sold up for this year and has booked considerable tonnage for delivery during the first half of 1918. Quotations are unchanged but firm at \$50. The demand for pig iron continues heavy, but

CANADIAN GOVERNMENT PURCHASING COMMISSION

The following gentlemen constitute the Commission appointed to make all purchases under the Dominion \$100,000,000 war appropriation:—George F. Galt, Winnipeg; Hormidas Laporte, Montreal; A. E. Kemp, Toronto. Thomas Hilliard is secretary, and the Commission headquarters are at Ottawa.

the furnaces, although operating at capacity, cannot cope with the situation. At Buffalo the market continues very strong with prices advancing. On foundry grades prices now range from \$45 to \$48 furnace for shipment over the remainder of the year; from \$42 to \$45 for shipment during the first quarter of 1918 and from \$40 to \$42 for shipment during second quarter.

Scrap

The scrap market is firmer with higher prices on some old materials. Consumers who had been holding off buying owing to prevailing conditions have now come into the market to replenish stocks. This situation was expected and although as a result the market is firmer, it is still unsettled. Coppers, No. 1 composition and new brass clippings have all advanced, ranging from 1 1/2 to 2c. Heavy melting steel is strong but unchanged. No. 1 machinery cast iron and malleable scrap have advanced \$3 a ton.

Machine Tools

There is no change in the situation in regard to machine tools. Local machinery houses report fair business general on lines of machine tools, but no outstanding

feature. Developments in the States, however, are being closely followed as the increased activity in the trade there will affect deliveries on imported equipment. Reports from machine tool centres in the States indicate that the trade is entering another period of great prosperity.

Supplies

Although there are no important price changes to note this week some advances may be looked for in the near future on account of the steady increase in cost of practically all raw materials. Current quotations are all very firm and business continues good. White lead has advanced and is now quoted at \$17.50 per 100 lbs., in ton lots, with 30c. extra for less than ton lots.

Metals

While the non-ferrous metal markets are firm, the situation continues unsettled owing to the lack of definite information with regard to the American Government's requirements. On this account buying is not particularly active, the general disposition being to await developments. The American Government has appointed a sub-committee on pig tin, thus bringing it in line with other non-ferrous metals. This should do much to improve the situation in regard to this metal. Copper continues quiet, but prices are firm in expectation of heavy demand. Spelter is unchanged, but lead has advanced owing to scarcity of spot metal. The antimony situation is unchanged, but a decline in aluminum may take place as the American Government has fixed a price of 27 1/2c. a pound as compared with 62c. prevailing in the outside market. Prices of solders have advanced due to the high cost of lead and tin. Business locally continues good with an upward tendency in prices.

Copper.—There has been no change in the copper situation and prices are firm at last week's level. It is not expected that there will be much change in the market until the American Government requirements are made known as to quantity and price agreement arrived at. It is, however, well understood that the Government needs will be heavy and also that the price will be pretty near the current outside market. The nearest copper which can be had just now from the leading producers is for July delivery, and there is very little of this now offering. Local prices are firm, lake and electrolytic being quoted at 37c. and castings at 36c. per pound.

Tin.—Although the market is a shade easier, prices are firm and underlying conditions point to renewed strength before long. The easier position in New York was due to freer arrivals of tin lately and a fair amount of metal on the way. Business has of late been quiet, there being a disposition to await developments following appointment of a sub-committee on pig tin by the American Government. Local price, 68c. per pound.

Spelter.—The market in New York is dull and unchanged. The trade is waiting to see what action the American Government may take in regard to their spelter requirements. The local situation is un-

changed, spelter being quoted at 12c. per pound.

Lead.—The market is quiet but prices continue very firm. There is very little business passing on account of the scarcity of lead. The principal producers are out of the market and only lead that can be had is held by dealers who ask from 1c. to 1½c. above the "trust" price, consumers are holding off as long as they can. Lead has advanced ¾c. locally and is now quoted at 14c. per pound.

Antimony.—There is no change in the antimony situation. Arrivals have been absorbed and prices are firm on the basis of current quotations, that is, 30c. per pound.

Aluminum.—There is no change in the price of aluminum, although it is understood that the American Government have fixed a price of 27½c. per pound as against 62c. prevailing on the outside market. Local price unchanged at 68c. per pound.

Solders.—The high cost of lead and tin is forcing up prices of solder. Strictly is now quoted at 38c. and guaranteed at 41c. per pound, being an advance of 2c. Prices of Babbitt metals now range from 16c. to 65c. per pound.

Sydney, N.S., May 19.—Since the date of the last letter, the Royal Commission gave its finding in the matter of the wages of the employees of the Nova Scotia Steel & Coal Co., as follows:—"Ordinary laborers, 12½ per cent. increase; other classes, from \$2.50 and under, 15 per cent. increase, including a number of hoisting enginemen; all classes from \$2.50 to \$3, 10 per cent. increase; all classes above \$3, 5 per cent. increase; handpick miners, 7½ per cent. increase; shooters and loaders, 7½ per cent. increase; machine runners, 5 per cent. increase; to become effective May 7, and all bonuses to be put on a flat rate.

"This award is to continue to 31st December, 1917, and from year to year thereafter, until or unless two months' notice by either party before the expiration of any calendar year is given of intention to terminate the agreement."

The Commission afterwards proceeded to Springhill Mines, for the purpose of reviewing the increases offered there by the Dominion Coal Co., with which the workmen were not satisfied. The Commission confirmed the company's offer, with some concessions in the matter of pillar getting rates, and the finding, as in the case of the Glace Bay and Sydney Mine Collieries, was accepted by the men as the basis of a settlement.

In the published report of the Commission to the Minister of Labor regarding the situation at the Glace Bay Collieries, the Commission states it was found that the causes of unrest were principally two, namely:—

"First, a feeling of discord resulting from the presence in the same field of two rival labor organizations. This feeling interfered in many ways with the successful prosecution of the industry in the different collieries, and produced widespread friction and irritation. The Commission was able to persuade the

leaders of the two organizations to agree to the establishment of a new organization, which is intended to absorb the membership of the two existing ones, and we believe that in due course this scheme will be carried into effect to the advantage of both employers and employees, as well as of the community. The Commission gave its unqualified approval of the proposition.

Since the sittings of the Commission, the proposal for amalgamation of the unions has been favorably reported on at meetings of the different lodges, and it seems probable that amalgamation will shortly be consummated.

With the month of May, weekly pays are substituted for fortnightly pays at the mines of Nova Scotia, in accordance with legislation passed at the 1916 session of the House of Assembly. It is yet too soon to say what the effect on production will be. So far in May, outputs have been well maintained, and production will approximate more closely to that of the corresponding month in the previous year than for a long time past. This is, however, partly due to the fact that it was about May, 1916, when outputs commenced to decline so very seriously.

A large amount of coal is being banked at the collieries because of the impossibility of obtaining ships to transport the coal to market. This has been occasioned by Admiralty requisition of the chartered ships of the Dominion Coal Co., and the practical impossibility of obtaining ships to replace them at freight rates which will make coal transportation commercially practicable.

CANADA'S TRADE BALANCE

WHILE the volume of Canada's trade with the rest of the world continued to show large expansion through the first four months of the present year, the expansion has been larger in what the country has been buying abroad than in what it has been selling. This will have been noted in a general way in connection with the April returns, which showed an excess of 21 millions in imports entered for consumption over exports of domestic produce, the first adverse balance reported for a good many months.

The total trade for the four months of the year, leaving aside the gold figures and exports of foreign produce, was 683 millions, against 499 millions in the corresponding period of 1916, and only 267 millions in the corresponding period of 1915, increases of approximately 40 per cent. and 155 per cent. respectively. Of the gain of 184 millions, however, as compared with 1916, 115 millions fell under the head of imports, against a 69-million gain in exports. So while Canada in the first four months of 1916 built up a favorable trade balance of 71 millions, the favorable balance for the first four months of 1917 is down to 25 millions. This is still by long odds the most favorable showing for the period with the exception of 1916, comparing with adverse trade balances of as much as 122 millions in 1913. None the less it is a retrograde movement at a time when high

prices for our agricultural output and huge orders for war supplies are being counted on to fortify the country's financial standing.

National Revenues

National revenues naturally continue buoyant under the large expansion in imports, Customs' collections in April, for instance, being \$13,875,485, against \$9,797,365 in April, 1916; but our interest obligations have increased with heavy outlays for war expenditure, and the main dependence for keeping the position steady, while the inflow of new capital for development is checked, rests in establishing and holding a favorable trade balance—in selling abroad a good deal more than we buy.

Comparisons of the trade record from January to April (four month periods) in each of the last six years follow:

Year.	Exports	Imports	Balance.
1917	\$354,891,404	\$329,497,238	\$ 25,394,166
1916	285,168,625	214,008,068	71,160,557
1915	181,286,747	136,045,451	47,587,704
1914	90,225,886	169,510,102	79,284,216
1913	99,119,323	221,795,966	122,676,643
1912	77,005,714	184,501,469	107,498,755

+ Favorable balance; — Adverse balance.

Only for the sharp falling off in April exports the favorable balance for the four months of the current year would have made a showing approximately as good as that of a year ago. Exports and imports for the first four months of the year compare as follows:

1917.	Exports	Imports	Balance.
Jan.	\$ 99,106,259	\$ 72,323,074	\$26,783,185
Feb.	68,224,383	68,030,469	193,914
March	122,415,313	102,335,886	20,079,427
April	65,145,449	86,807,809	21,662,360
Total	\$354,891,404	\$329,497,238	\$25,394,166

May Expectations.

It may safely be presumed that the sharp decrease in exports in April, as compared with March—they were only little more than half the March total—was due to shipping difficulties. The opening of navigation and the outrush of grain for Europe should result in very substantial gains in May export figures, at least under the head of agricultural exports. The grain is badly needed in Europe and ships must be found to carry it. The decline in the premium on New York funds in the past few days has already been noted as an indication that wheat is moving again in large volume.

April figures have never been particularly good in the matter of exports. Still, last year and also in 1915 Canada managed to show a small excess of exports over imports. Comparisons for six years follow:

April	Exports	Imports	Balance.
1917	\$65,145,000	\$86,807,000	\$21,662,000
1916	55,092,000	50,147,000	4,945,000
1915	28,691,000	28,391,640	300,000
1914	17,753,000	36,937,000	19,184,000
1913	22,016,000	48,488,000	26,472,000
1912	13,676,000	45,607,000	31,931,000

The April exports in their usual classification compare with those of April, 1916, and of March, 1917, as follows:

	April, 1917	April, 1916	March, 1917
Mine	\$ 3,889,510	\$ 3,690,744	\$ 9,980,711
Fisheries	648,336	529,515	2,373,258
Forest	2,461,312	2,287,939	3,614,385
Animals	5,711,691	5,112,105	11,809,941
Agricultural	11,443,161	21,305,977	21,962,252
Manufact.	40,539,646	41,573,078	69,239,486
Miscell.	328,793	292,677	433,280

NIAGARA FALLS POWER CO. REPORT

THE pamphlet report of the Niagara Falls Power Co., for the year ending Dec. 31, 1916, says that all permitted means have been taken to meet the rapidly-increasing demand for power. Two additional generating units in the Canadian plant have been completed and placed in service. A third unit is now in process of being added. The management points out that the rapid increase in power use in Canada has led the Government to reduce considerably the permits for the exportation of Niagara power, and adds:—"The export license of our Canadian company has been reduced from 75,000-horsepower to 30,000 horse-power. We have, therefore been obliged to withdraw 45,000 horse-power from American industries, despite insistent demands."

INTERNATIONAL NICKEL CO.

The new \$4,000,000 refining plant of the International Nickel Co., at Port Colborne, Ont., has all the foundations completed and the steel work on the main building finished. The first nickel will probably be turned out December next. The plant lies east of the entrance to the Welland Canal and has good transportation by rail and water. The initial output will be 15,000,000 pounds of refined nickel a year, with provision made for an output three or four times that amount. The operating force will be between three and four hundred men. Most of the construction supplies have been purchased in Canada. In operation, the plant will consume 100,000 tons a year of coal, coke, cordwood, fuel oil, nitre cake, charcoal, silica, rock salt, soda ash, soda nitrate, sulphuric acid, fire clay, and fire brick in addition to the copper nickel matte which will be supplied from the company's mines at Sudbury.

FOUNDRYMEN'S CONVENTION AND EQUIPMENT EXHIBITION

NEW ENGLAND foundrymen already are making extensive preparations for the reception and entertainment of the members of the American Foundrymen's Association and the American Institute of Metals, who will meet in annual convention at Boston during the week of Sept. 24. Concurrent with this great gathering of foundrymen will be held the yearly exhibition of foundry equipment and supplies, machine tools and accessories, in Mechanics' Building, which affords 80,000 square feet of floor space.

Never before in the history of these organizations has as much interest been manifested in this event, so far in advance of the opening date, as this year. Space reservations for exhibits already have been made by 80 manufacturers, and last year's total of 150 at Cleveland, promises to be greatly exceeded. The average space per exhibitor also shows a big increase over previous years and the indications are that Mechanics' Building will be crowded to capacity. A prominent feature of the Boston show will be the extensive display of machine tools. New England builders promise to be unusually well represented and num-

erous reservations also have been made by machine tool builders in the central west.

The Boston exhibition will be a great patriotic demonstration of the preparedness of equipment builders to meet the most exacting needs of foundrymen and machine shop operators in this great crisis. The labor-saving tools that will be displayed will demonstrate how operations can be speeded-up to meet the demands of the Government, and, in addition, engineers will be in attendance who will explain the intricacies of munitions manufacture.

The programme for the technical sessions of the American Foundrymen's Association is unusually complete, and provides for separate sessions for the discussion of grey iron, steel, and malleable iron topics. Three symposiums have been scheduled, namely, "Military Stores," "After-treatment of Castings to Improve Their Physical Characteristics," and "Refractories." The opening meeting on Monday afternoon, Sept. 24, will be a joint session of the American Foundrymen's Association and the American Institute of Metals. Throughout the remainder of the week, ending with Friday, Sept. 28, only morning sessions will be held and the same plan will be followed, which proved so satisfactory at Cleveland last year. It is probable that simultaneous sessions of the malleable and grey iron and steel sections will be held Wednesday, Thursday and Friday. The exhibition will be formally opened Tuesday morning, Sept. 25, and will close Friday evening.

Headquarters for the American Foundrymen's Association will be at the Copley-Plaza Hotel, although the meetings will be held in the Mechanics' Building. The American Institute of Metals will have its headquarters at the Hotel Somerset and its meetings will be held at this hotel or in the exhibition building.

The foundrymen of New England have completed a strong organization to provide for the reception and entertainment of the visitors. While their plans have been outlined only tentatively, the programme includes a boat trip around Boston harbor, theatre party, a visit to one of the big league parks to witness a professional hall game, ladies' luncheon and plant visitation. The complete list of committees appointed by the New England Foundrymen, follows:—

EXECUTIVE COMMITTEE.

- W. J. Lavelle, chairman, New England Coal & Coke Co., Everett, Mass.
- J. O. Henshaw, 79 Milk St., Boston.
- C. A. Reed, Reed, Fears & Miller, Boston.
- R. D. Walker, Walker & Pratt Mfg. Co., Boston.
- W. E. Freeland, The Iron Age, Worcester.
- A. R. Plant, Blackstone National Bank, Providence, R.I.
- W. A. Viall, Brown & Sharpe Mfg. Co., Providence, R.I.
- Fred E. Stockwell, Barbour-Stockwell Co., Cambridge, Mass.
- A. B. Root, Jr., Hunt-Spiller Mfg. Corp., Boston.
- T. R. Scott, Brown & Sharpe Mfg. Co., Providence, R.I.

RECEPTION COMMITTEE.

- E. A. Tutin, chairman, Thomas Iron Co., Boston.
- H. Paul Buckingham, Arcade Malleable Iron Co., Worcester.
- H. F. Winlock, Barbour-Stockwell Co., Cambridge, Mass.
- George H. Gibby, Gibby Foundry Co., Boston.
- W. Scott Thomas, J. W. Paxson Co., Providence, R.I.

- F. B. Farnsworth, McLagon Foundry Co., New Haven, Conn.
- George A. Ray, Taylor & Fenn Co., Hartford, Conn.
- H. W. Woodworth, American Tool & Machine Co., Boston.
- Charles Van Stone, Lumsden & Van Stone Co., Boston.
- D. D. Bartlett, Builders' Foundry Co., Providence, R.I.
- F. W. Stickle, Capitol Foundry Co., Hartford, Conn.
- Robt. C. Newcomb, Deane Steam Pump Works, Holyoke, Mass.

FINANCE COMMITTEE.

- W. A. Viall, chairman, Brown & Sharpe Mfg. Co., Providence, R.I.
- H. A. Carpenter, General Fire Extinguisher Co., Providence, R.I.
- W. J. Breen, Wm. J. Breen Co., Boston.
- A. N. Abbe, American Hardware Corp., New Britain, Conn.
- A. R. Plant, Blackstone National Bank, Providence, R.I.
- A. J. Miller, Whitehead Bros. Co., Providence, R.I.
- W. C. Fish, General Electric Co., Lynn, Mass.
- L. G. Kibbe, Turner & Seymour Co., Torrington, Conn.

LADIES' ENTERTAINMENT COMMITTEE.

- R. D. Walker, chairman, Walker & Pratt Mfg. Co., Boston.
- L. S. Brown, Springfield Facing Co., Springfield, Mass.
- Charles L. Newcomb, Deane Steam Pump Works, Holyoke, Mass.
- Robt. C. Bird, Broadway Iron Foundry, Cambridge, Mass.
- Carl S. Dixon, General Electric Co., Pittsfield, Mass.
- W. H. Coffin, Springfield Facing Co., Springfield, Mass.
- J. F. Lanigan, Davis Foundry Co., Lawrence, Mass.
- W. M. Saunders, Saunders & Franklin, Providence, R.I.

ENTERTAINMENT COMMITTEE.

- C. A. Read, chairman, Reed, Pears & Miller, Boston.
- W. T. Bennett, secretary, Griffin Wheel Co., Chelsea, Mass.
- S. E. French, Athol Machine Works, Athol, Mass.
- T. Officer, Sullivan Machinery Co., Claremont, N.H.
- A. F. Crobin, Union Mfg. Co., New Britain, Conn.
- H. A. Nealley, Jos. Dixon Crucible Co., Boston.
- G. P. Aborn, Blake & Knowles Steam Pump Works, Cambridge, Mass.
- C. A. Olson, Walworth Mfg. Co., Boston.
- B. S. Leslie, United Shoe Machinery Co., Beverly, Mass.
- T. R. Scott, Brown & Sharpe Mfg. Co., Providence, R.I.
- Chas. V. S. Paul, R. Estabrook's, Sons, Boston.
- Charles L. Nutter, Old Colony Foundry, Bridgewater, Mass.
- C. E. Hildreth, Whitcomb-Blaisdell Machine Tool Co., Worcester, Mass.
- E. B. Freeman, B. F. Sturtevant Co., Hyde Park, Mass.
- D. F. Eagan, Hotel Seymour, Lynn, Mass.
- D. F. Curtin, Waltham Foundry Co., Waltham, Mass.
- A. L. Haasis, Jos. Dixon Crucible Co., Jersey City, N.J.

GOLF COMMITTEE.

- J. O. Henshaw, chairman, 79 Milk St., Boston.
- A. E. Blazo, Rogers, Brown & Co., Boston.
- C. A. Wyatt, Debevoise-Anderson Co., Boston.
- Thomas F. Stokes, Alley & age Co., Boston.

PRESS COMMITTEE.

- W. E. Freeland, chairman, The Iron Age, Worcester, Mass.
- A. W. Howland, The Foundry, 90 West St. Bldg., New York.
- A. O. Backert, Cleveland.

POPULAR TAXATION.

We must learn by degrees the art of raising heavy revenue from taxation. To be effective, levies must be popular. American public opinion, peculiarly averse to taxes, can not be expected to change over night from a parsimonious attitude toward customs and levies to one of British or French unquestioning liberality.

France's budget for three months' war is announced at nearly two billions; it has excited no special comment in that country. The expenditure contemplated is proportionately equal to our own.

In December, 1915, the Chancellor of the Exchequer estimated the national wealth of the United Kingdom at seventy-three billions of dollars and national income was shortly after placed by Sir George Paish at fifteen billions. Revenue from customs, excise, income and other taxes for the year ended March, 1916, amounted to over two billions eight hundred millions.

It would be futile to attempt any proportionate revenue plan here. Our income is not similar.

Enlarged Canadian Trade Intelligence Service

Under the arrangement made by the Minister of Trade and Commerce with Sir Edward Grey in July, 1912, the Department of Trade and Commerce, Ottawa, is able to present the following list of the more important British Consulates whose officers have been instructed by the Foreign Office to answer inquiries from and give information to Canadians who wish to consult them in reference to trade matters.

BRAZIL—Bahia, British Consul. Rio de Janeiro, British Consul General.	NETHERLANDS—Amsterdam, British Consul.
CHILE — Valparaiso, British Consul General.	PANAMA—Colon, British Consul. Panama, British Vice-Consul.
COLOMBIA — Bogota, British Consul General.	PERU—Lima, British Vice-Consul.
ECUADOR—Quito, British Consul General. Guayaquil, British Consul.	PORTUGAL—Lisbon, British Consul.
EGYPT — Alexandria, British Consul General.	RUSSIA—Moscow, British Consul General. Petrograd, British Consul. Vladivostock, British Consul. Odessa, British Consul General.
FRANCE—Havre, British Consul General. Marseilles, British Consul General.	SPAIN—Barcelona, British Consul General. Madrid, British Consul.
INDIA—Calcutta, Director General of Commercial Intelligence.	SWEDEN—Stockholm, British Consul.
ITALY—Genoa, British Consul General. Milan, British Consul.	SWITZERLAND—Geneva, British Consul.
MEXICO—Mexico, British Consul General.	URUGUAY—Monte Video, British Vice-Consul.
	VENEZUELA — Caracas, British Vice-Consul.

Canadian Commercial Intelligence Service

The Department of Trade and Commerce invites correspondence from Canadian exporters or importers upon all trade matters. Canadian Trade Commissioners and Commercial Agents should be kept supplied with catalogues, price lists, discount rates, etc., and the names and addresses of trade representatives by Canadian exporters. Catalogues should state whether prices are at factory point, f.o.b. at port of shipment, or, which is preferable, c.i.f. at foreign port.

CANADIAN TRADE COMMISSIONERS.

ARGENTINE REPUBLIC—B. S. Webb, Acting Canadian Trade Commissioner, Reconquista, No. 46, Buenos Aires. Cable address, Canadian.
AUSTRALIA—D. H. Ross, Stock Exchange Building, Melbourne. Cable address, Canadian.
BRITISH WEST INDIES—E. H. S. Flood, Bridgetown, Barbadoes, agent also for the Bermudas and British Guiana. Cable address, Canadian.
CHINA—J. W. Ross, 13 Nanking Road, Shanghai. Cable address, Canada.
CUBA—A. T. Quilez, Acting Canadian Trade Commissioner, Lonja del Comercio, Apartado 1290, Havana. Cable address, Cantracom.
FRANCE—Phillipe Roy, Commissioner General, 17 and 19 Boulevard des Capucines, Paris. Cable address, Stadacona.
JAPAN—E. F. Crowe, Acting Canadian Trade Commissioner, P. O. Box 109, Yokohama. Cable address, Canadian.
HOLLAND—P. H. Geleerd, Acting Canadian Trade Commissioner, Zuidblaak, 26, Rotterdam. Cable address, Watermill.
RUSSIA—C. F. Just, Canadian Government Commercial Agent, Alexandrinskaia, Plosch 9, Petrograd. L. D. Wilgress, Canadian Government Commercial Agent, Bakhgolza Ulitsa No. 4, Omsk, Siberia.
NEWFOUNDLAND—W. B. Nicholson, Bank of Montreal Building, Water Street, St. John's. Cable address, Canadian.
NEW ZEALAND—W. A. Beddoe, Union Buildings, Customs Street, Auckland. Cable address, Canadian.
SOUTH AFRICA—W. J. Egan, Norwich Union Buildings, Cape Town. Cable address, Cantracom.
UNITED KINGDOM—Harrison Watson, Sub-division E.C., 2, 73 Basinghall Street, London, E.C., England. Cable address, Sleighing, London. N. D. Johnston, Sun Building, Clare Street, Bristol. Cable address, Canadian. J. E. Ray, Central House, Birmingham. Cable address, Canadian. J. Forsyth Smith, 31 North John Street, Liverpool. Cable address, Cantracom. F. A. C. Bickerdike, 4 St. Ann's Square, Manchester. Cable address, Cantracom. J. Forsyth Smith, Acting Canadian Trade Commissioner, 57 Union Street, Glasgow, Scotland. Cable address, Cantracom.

CANADIAN COMMERCIAL AGENTS

AUSTRALIA—P. Millin, Royal Exchange Building, Sydney, N.S.W.
BRITISH WEST INDIES—Edgar Tripp, Port of Spain, Trinidad. Cable address, Canadian. R. H. Curry, Nassau, Bahamas.
NORWAY AND DENMARK—C. E. Sontum Grubbegd No. 4, Christiania, Norway. Cable address, Sontums.
SPAIN—J. F. Roberts, Care British Consulate General, Barcelona.

CANADIAN HIGH COMMISSIONER'S OFFICE

UNITED KINGDOM—W. L. Griffith, Secretary, 17 Victoria Street, London, S.W., England. Cable address, Dominion, London.

our assets are not similar and our viewpoint of taxes is not similar.

A large part of our dividends and interest is, in fact, industrial profit. In sharp contrast to the investment class of other countries, our investors operate the industries in which they are interested. Our "capitalists," as they are called, are in fact industrial workers, hard workers personally, and not by deputy. They have created the investments they own.

The assets from which these profits and wages are earned are largely immobile or at least slow moving. They have never been as yet properly appraised and are spoken of only in general and vague terms of many billions.

Even in times of peace the private income of the United Kingdom paid four times as much in national taxes as our own, counting customs as taxes. We are not as willing to pay taxes as our English cousins, because we have not been so much accustomed to them. Our income has been in earned wages and profits in the nature of wages from our business, which is to produce and manufacture and carry our products. Our enterprise calls for the active employment of all of our liquid capital most of the time.

To render taxation popular—to increase public willingness to raise revenue, Congressional appreciation of our distinctive economic cleavage is essential. Our capacity is an earning capacity. Taxation ought to be chiefly of our products, not of production.—Wall Street Journal.



CATALOGUES

Grinder.—The Webster & Perks Tool Co., Springfield, Ohio, have distributed to the trade a leaflet describing and illustrating their regular No. 1 grinder, floor or bench type. A specification giving the principal sizes is included together with list prices.

SKF Ball Bearings.—A pocket list of ball bearings issued by the Canadian SKF Co., Toronto, contains primarily a series of tables giving the dimensions, maximum loads and prices of different sizes of bearings covering all types. Other matter includes illustrations of radial and thrust ball bearings and also a brief description covering the constructional features of the SKF bearings.

BOOK REVIEW

Manufacture of Artillery Ammunition, by L. P. Alford, and associate editors of the *American Machinist*. 777 pages, 6 x 9 ins., and about 675 illustrations. Published by McGraw-Hill Book Co., New York city. Price \$6. This book forms a convenient and interesting work of reference as well as a permanent record of munitions-making methods on the North American continent. The subject matter is divided into four sections: Shrapnel, high-explosive shells, cartridge cases, and fuses. Detailed descriptions of each operation, types of machines, and devices employed with output records, imparts more than a passing value to the accumulated data. Much of the information has previously appeared in the *American Machinist*, the efforts of the staff having been supplemented by a few contributors. The illustrations are excellent and profuse, working drawings being fully dimensioned wherever possible. An appendix of 30 pages includes notes on: Machine Tools for Munitions Manufacture—Composition and Properties of Shell Steel—Light Shells—Details of Some Shrapnels—Details of Some High Explosive Shells—British Requirements for Projectile Inspection, etc.

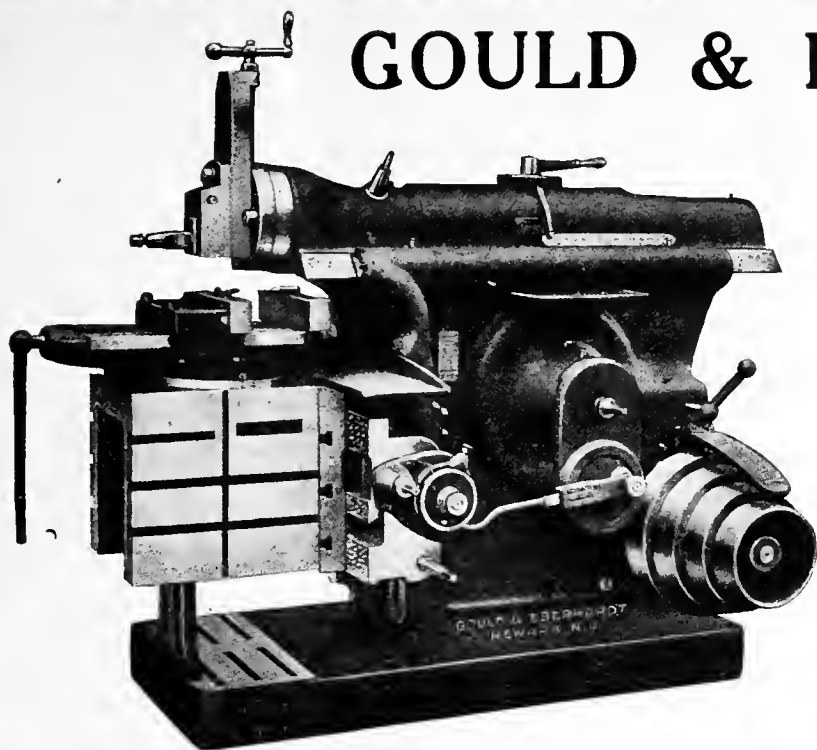

GOULD & EBERHARDT SHAPERS in Stock

20" and 24" Sizes

28" "Invincible" July delivery

Write for literature describing
the Double Triple Quick Stroke
and other original features.

IMMEDIATE SHIPMENT.

The A. R. Williams Machinery Company, Limited

ST. JOHN, N.B.
WINNIPEG, VANCOUVER

"If It's Machinery, Write Williams"

64 Front Street West,
TORONTO

There is Absolute Satisfaction



In Geometric Self-opening and Adjustable
Screw-cutting Die Heads.

We specialize on Threading Tools, and
manufacture nothing else.

All our efforts are directed to building
Screw-Cutting Tools a little better than
anyone else builds them.

Take up your Threading proposition with
us. Get acquainted with our products
now. Order when you please.

The Geometric Tool Co.
New Haven, Conn.

Canadian Agents:
Williams & Wilson, Ltd., Montreal. The A.R. Williams
Mchy. Co., Ltd., Toronto, Winnipeg, St. John, N.B.

If any advertisement interests you, tear it out now and place with letters to be answered.

INDUSTRIAL ^A_N^D CONSTRUCTION NEWS

Establishment or Enlargement of Factories, Mills, Power Plants, Etc.; Construction of Railways, Bridges, Etc.; Municipal Undertakings; Mining News

ENGINEERING

Quebec, Que.—Louis Lavoie is building a machine shop here.

Winnipeg, Man.—The city will expend \$60,000 on erecting new street lamps.

Windsor, Ont.—The Maxwell Motor Co. contemplate erecting a factory here.

Welland, Ont.—Electro-Metals, Ltd., will build additions to their plant, costing \$50,000.

Three Rivers, Que.—The Three Rivers Casting Co. are building a foundry and forging plant here.

Toronto, Ont.—The William Davies Co. will build an extension to their boiler house on Front Street East at a cost of \$6,000.

Montreal, Que.—The Howard Smith Paper Mills have under consideration the installation of a 11,000-h.p. hydro-electric unit at Crabtree Mills.

Renfrew, Ont.—The town has purchased the Renfrew Power Co.'s water rights, hydraulic and electrical equipment. The price was \$100,000.

Niagara Falls, Ont.—The Niagara Falls Power Co. is installing a third generating unit, two having recently been completed and placed in service.

Port Arthur, Ont.—The Hennepin Mining Co., which was recently incorporated, will likely establish a smelter here. W. F. Langworthy is interested in the project.

Brantford, Ont.—An effort will be made to have a hydro-electric system installed here. A by-law was carried some years ago, but nothing further was done.

Brandon, Man.—The Brandon Machine Implement Works, whose plant was destroyed by fire over a year ago, are starting to manufacture a cultivator, and will probably enlarge their plant for this purpose.

Toronto, Ont.—The Hoyt Metal Co. have received a permit to build an addition to their factory on Eastern Ave., near the north-east corner of Lewis St., at a cost of \$5,000.

Sidney, C.B.—It is understood that the Dominion Steel Corporation will start operations again at their rail mill. A considerable tonnage of rails is required for renewals for the Intercolonial Railway.

Winnipeg, Man.—Fire on May 16 destroyed the greater part of the buildings and equipment of the Winnipeg Foundry Co. The loss is estimated at \$20,000, with only \$4,000 insurance. J. H. Pace is president of the company.

Alliston, Ont.—The town, on May 21, accepted Hydro-Electric service by a vote of the people, which was practically

unanimous. Two by-laws were submitted to the people. The response to the enabling by-law was unanimous, while the by-law to issue debentures to cover the cost of installation was given 280 affirmative and 3 negative votes.

GENERAL

Pembroke, Ont.—Fire destroyed the mills of the Colonial Lumber Co. last Monday, causing loss of \$140,000. The origin is unknown.

Montreal, Que.—Construction work is under way on the erection of a factory the Montreal Box Board Co., to cost \$20,000.

Chambly, Que.—Work will start shortly on the construction of a factory for the Canadian Leatherboard Co. G. B. Mitchell, of Montreal, is the general contractor.

Elmwood, Man.—The Stewart Sheaf Loader Co., will shortly commence the erection of a modern factory in Elmwood. The building which will have the latest appliances will be one story in height.

Peterborough, Ont.—It has been announced that the initial cost of the new plant of the Quaker Oats Co. will be \$1,500,000. The main plant will be eight storeys high and will replace the structure that was destroyed by fire in December last. A by-law to authorize the construction of an overhead bridge and a smaller traffic bridge will be voted upon May 31st.

ELECTRICAL

Drayton, Ont.—A by-law will be submitted to the ratepayers on June 4th to raise \$9,500 by debentures for a hydro-electric system.

Omeme, Ont.—The Hydro-Electric Power Commission has informed Emily Township Council that, consequent upon an agreement with the village of Omeme for the distribution of power for electric light, etc., in the village, and the erection of a sub-station for this purpose, they will be in a position to distribute power to farmers within a certain radius of the village.

CONTRACTS

Montreal, Que.—The Montreal Tramways Co. have awarded a contract to the Canadian Westinghouse Co. for a 12,500-k.w. steam turbo-generator for the power station at Hochelaga.

North Bay, Ont.—The tender for building the new toy factory has been awarded to Henderson Angus. The contract price was \$12,975 and \$10 per cubic yard for extra concrete.

Kincardine, Ont.—Tenders for the purchase of the rails and other material of the West Shore Railway were opened at a meeting of representatives of the interested municipalities held recently at Kincardine. The tender of the Ontario Hydro-Electric Commission was the highest and was accepted. For the track (including rails, fish-plates, spikes, etc.) the figure was \$40 a gross ton; for the rails of Kincardine and along the right of way, \$45 a ton; for the bolts out of track, \$5 per cwt.; for spikes out of track, \$80 per short ton; for fish-plates out of track, \$45 per gross ton; for the structural steel, 5c. a pound. The poles and ties were not sold. It is roughly estimated that at these prices about \$120,000 will be realized from the sale of the material.

MUNICIPAL

Wolseley, Sask.—The Town Council recently passed a \$9,000 by-law providing for extensions to the municipal light and power plant.

Mitchell, Ont., ratepayers carried by-laws to issue debentures to improve the roads and to give a site and a fixed assessment to the Burritt Company.

Elmira, Ont.—The rate-payers voted on two industrial by-laws last Monday, one for a loan of \$15,000 to the Machinery & Transmission Co., as an inducement to erect a large addition to their plant, and the other a small inducement to the Phonola Co. of Canada to commence operations in the Interior Woodwork Co. building. Both by-laws carried by the necessary two-thirds majority.

TENDERS

Three Rivers, Que.—The City Council are receiving bids on four turbine pumps, each having a capacity of between 2½ and 3 million gallons per day.

Paris, Ont.—The Town Council are calling tenders for a centrifugal pump with a capacity of 750 gallons per minute. Full particulars may be obtained from G. H. Armstrong, sec.-treasurer.

Trail, B.C.—Tenders will be received up to June 6 for work in connection with the extension of the waterworks system. Plans and specifications may be seen at office of W. E. B. Monypenny, city clerk, or at office of A. L. McCulloch, consulting engineer, Nelson, B.C.

Stratford, Ont.—Tenders will be received up to June 11 for furnishing and constructing a radial brick or concrete chimney and foundations for the refuse incinerating plant on St. Patrick Street, Stratford. Specifications and forms of tender may be obtained from the office of the city engineer, A. B. Manson.

Aikenhead's

"Van Dorn"

**Portable Electric Drills
Reamers and Grinders**



THEY consume current only when working, and any lamp socket is a source of power. You will find hundreds of uses for them around your shop and they are dependable. Special fan-cooled Van Dorn motor has 100% overload capacity. Van Dorn make-and-break switch acts so quickly that it practically eliminates the sticking and fusing of contacts. Phosphor bronze and ball bearing. Gears cut and hardened. All parts 100% oversize.

Do more work at less cost and they stay on the job.

For Full Particulars, Write

AIKENHEAD HARDWARE LIMITED

17, 19, 21 TEMPERANCE STREET, TORONTO

Aikenhead's
**Wahlstrom
Automatic
CHUCKS**

You can save 20%
on Tapping Jobs.

Possibly you don't
think this can be
done, but the
Pierce-Arrow Co.
did it, with

**Wahlstrom
Automatic Chucks**

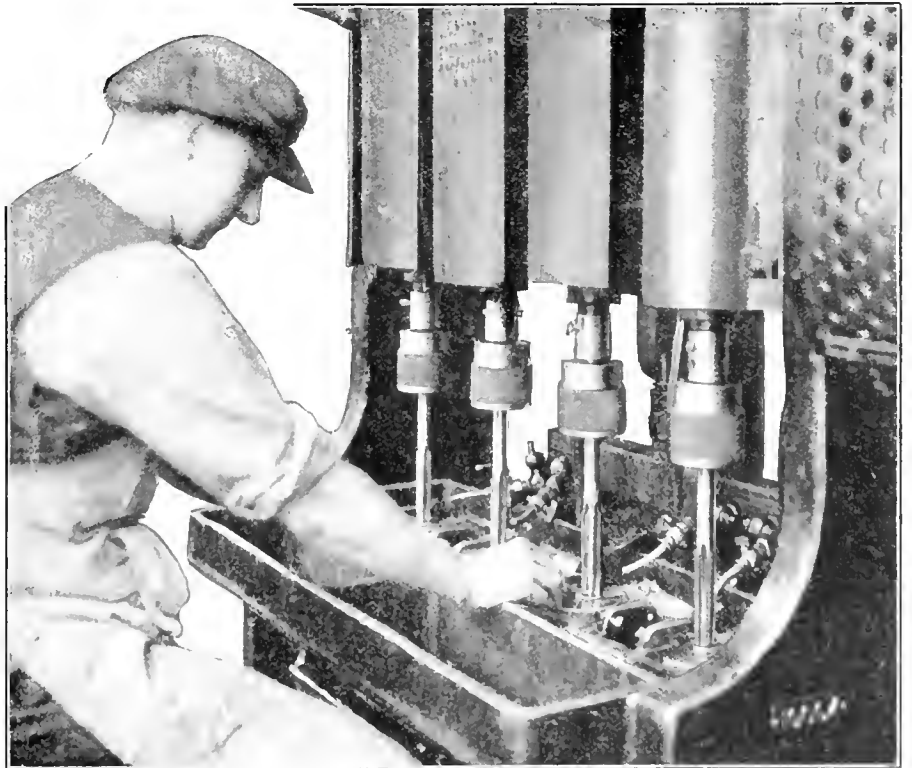

Aikenhead Hardware Limited, 17 Temperance Street
Toronto

If any advertisement interests you, tear it out now and place with letters to be answered.

Inferior tools and good mechanics don't co-operate—

In other words, you cannot get an A-1 production from a good man if you don't supply him with the best tools.

You will be sure of getting top notch file efficiency if you supply your mechanics with

"DELTA" FILES

Delta Files fairly eat the metal, and they hold their keen cutting edge longer than other makes—a fact that we can easily prove.

The "Delta" is the only line of files from 3 to 24 inches made absolutely of crucible steel, and their manufacture is guided by half a century's file making experience.

There is a shape and size to suit every requirement.

Our trade-mark (satisfaction - or - money - back-guarantee) is on every tang.

Sold by all reliable dealers.



DELTA FILE WORKS

PHILADELPHIA, PA. U.S.A.

CANADIAN AGENTS:

H. S. Howland, Sons & Co., Toron
Starke, Seybold, Montreal
Wm. Stairs, Son & Morrow, Halifax
Merrick-Anderson Co., Winnipeg
ALL LEADING JOBBERS



Brampton, Ont.—Tenders will be received up to June 5 for the several trades required in the erection of a school building for the Brampton High School Board. Plans and specifications may be seen at the office of the architects and at the office of R. H. Pringle, secretary of the board, Dominion Bank Chambers, Brampton, Ont. Wickson & Gregg, architects, Toronto.

Toronto, Ont.—Tenders will be received up to June 5 for the sale and removal of four horizontal return tubular boilers from the west boiler room of the City Hall, Toronto. Copy of terms and conditions may be seen and tender form obtained, together with all information relative thereto, at the offices of the Property Department, City Hall.

St. Catharines, Ont.—Tenders will be received up to June 5 for one gasoline engine, 10-12 h.p.; two single-stage centrifugal pumps with valves, pipes, fittings and shafting; one electric motor and automatic starter. General plan and specifications and form of tender may be obtained from the office of W. P. Near, the City Engineer, St. Catharines, or from P. Gillespie, Engineering Building, University of Toronto, Toronto.

MARINE

Victoria, B.C.—A shipbuilding company has been organized here with a capital of \$500,000. T. O. Cameron, of the Cameron Lumber Co., is interested in the proposition.

St. Catharines, Ont.—The steamer Nipigon, bound up, carried away the two head gates of Lock 1, Welland Canal, on the evening of May 26, tying up navigation until the following night.

New Westminster, B.C.—It was reported that twenty-five wooden steamships will be built in British Columbia by the Imperial Munitions Board, and of this number probably eight will be built here.

South Vancouver, B.C.—Announcement was made at the meeting of the South Vancouver Board of Trade recently that a contract had been signed with the firm of Lamond & Harrison for the building of a wooden ship, 225 feet long, 44 feet wide and having a draft of 19 feet. The cost of the vessel will be approximately \$225,000.

Victoria, B.C.—R. P. Butchart and Capt. Troup have arrived here from Ottawa with plans and specifications of the wooden ships that it is proposed to construct on the Coast. They will visit shipyards and possible sites for new plants. They are prepared to give contracts to builders who can demonstrate that they are in a position to fill them.

Vancouver, B.C.—The British steamer Ikeda of Vancouver, which was launched last month, is now formally registered from Vancouver, the papers having gone through at the Custom-house here a few days ago. The vessel was built at Stockton-on-Tees by Richardson, Duck & Co., Ltd., for the Union Steamship Co. of British Columbia, of which E. H. Beazley is manager. She is 410 feet long, 52 feet

7 in. beam, and 29 feet 5 in. deep. She is 4,760 tons net register, 9,935 tons displacement, and will carry 8,800 tons of cargo deadweight. She has 2,000 indicated horse-power, which give her a speed of ten knots, and her triple-expansion engines are 26, 42 and 70 by 48-inch stroke.

BUILDINGS

Toronto, Ont.—The Penfound Varnish Co. will build an extension to their factory at a cost of \$1,400.

Cobourg, Ont.—Work has been started in transforming the old Customs building to a factory for the Bird-Archer Co., who are locating here. They will manufacture boiler supplies. Some of the machinery has arrived in town and is being installed. M. Jex & Co. have the contract.

PERSONAL

Alfred W. Smithers, chairman of the Board of Directors of the Grand Trunk Railway, is visiting Canada in the interests of the company.

Wm. Rodger, who has been chief draughtsman with the Jenckes Machine Co. of Sherbrooke, Que., for the past eighteen months, has accepted a position as construction engineer with Fraser Brace and Co., of Montreal, contracting engineers.

Antoine Balzola, president and secretary-treasurer of the Niagara Spanish Aerial Car Tramway over the whirlpool, had died suddenly at his residence at Niagara Falls, Ont., on May 21. He was the chief promoter and constructed the novel aerial car tramway over the whirlpool. His home is in Spain, and he was about 45 years of age.

Thomas J. Dillon, whose appointment as general manager of Canada Foundries and Forgings, Ltd., is announced, has heretofore had jurisdiction only over the western plants at Welland, Ont., the Canada Forgings and Billings and Spencer. This now extends to the James Smart Manufacturing plant at Brockville. Mr. Dillon, who is also one of the directors of the company, is one of the most successful forge managers in Canada, having been associated with the business for many years and virtually brought up in it.

Charles A. Hayes, who will succeed F. E. Gutelius as general manager of the Canadian Government Railway systems, has been acting as general traffic manager of the Intercolonial Railway, having joined that system when he left the Grand Trunk about four years ago. Mr. Hayes was born at West Springfield, Mass., in 1865, and is, therefore, in his 52nd year. He entered the railway service in 1882, and before joining the Grand Trunk was connected with several lines in the United States. He became manager of the National Despatch, Great Eastern Line, in 1902, and in 1903 was made assistant general freight agent of the Grand Trunk, which position he held

for five years before he became general agent for the system.

INCORPORATIONS

The National Abrasive Co., has been granted an Ontario provincial license to manufacture abrasives of all kinds at Hamilton, Ont., with a capital not to exceed \$60,000. J. Ross Ritchie of Toronto is the company's attorney.

Canadian Des Moines Steel Co., has been incorporated at Ottawa with a capital of \$100,000 to acquire and take over the Chatham Bridge Co., of Chatham, Ont. The incorporators are R. L. Brackin, B. L. Bedford and E. W. Reeve all of Chatham, Ont.

The Wheel & Foundry Co. has been incorporated at Ottawa with a capital of \$25,000 to carry on the business of iron and steel founders, engineers etc. The head offices are at Toronto, and the incorporators are A. T. Thomson, W. S. Morlock and R. H. Parmenter all of Toronto.

Dale Engineering Co., has been incorporated at Ottawa with a capital of \$40,000 to carry on the business of a construction and Contracting Co., at Toronto. The incorporators are Samuel R. Birch, John F. Lennox and Harry C. Moore all of Toronto.

The McCord Mfg., Co., has been granted an Ontario provincial license to manufacture motors, engines, and machinery of all kinds. The capital is not to exceed \$50,000 and the company's attorney is A. R. Bartlet of Windsor, Ont.

Wells Bros. Construction Co. of Canada Ltd., has been licensed at Toronto to construct and erect buildings and carry on a general contracting business. The capital of the company is not to exceed \$20,000. J. T. Purvis of Toronto is the company's attorney.

Dominion Molybdenites Ltd., has been incorporated with a capital of \$1,000,000 at Toronto to acquire and develop mineral lands and deposits. The head office is at Toronto and the incorporators are Kenneth A. McRae, William J. Lockwood and Kenneth McKay all of Toronto.

The Republic Stamping & Enameling Co., have obtained a provincial license to establish and operate a general stamping and enameling business. The capital of the company is not to be greater than \$40,000, and the attorney is Charles H. Ivey of London, Ont.

Gederich Drydock & Shipbuilding Co., has been incorporated at Ottawa with a capital of \$1,000,000 to carry on a shipbuilding business and make machinery appliances and engines etc., at Goderich, Ont. The incorporators are David T. Grant, Mervil Macdonald and P. E. F. Smiley, all of Toronto.

Edwin S. Woods & Co., has been incorporated at Ottawa with a capital of \$40,000 to manufacture railway supplies, engines, boilers and machinery of all kinds at Montreal. The incorporators are L. A. David, L. P. Grepeau and S. H. R. Bush all of Montreal.

"HAWK" D CHROME VANADIUM STEEL



Will
Give You
Exceptional

Shell Forging Production

WITHOUT AN EQUAL FOR
BOTH FIRST AND
SECOND OPERATION
PUNCHES.

Comes to you heat-treated
and ready for use.

It does not stick to the
work.

There are many cases where
each punch has turned out
over 2,000 shells.

It means more shells, per
machine per day.

STEEL OF EVERY
DESCRIPTION.

Hawkridge Brothers Company

303 Congress St., BOSTON, MASS.
U. S. A.

TRY HAMILTON BABBITTS

We Make Nothing Else
GEO. E. JOBBORN, Hamilton, Ont.

PURO

(MADE IN CANADA.)

Saves Dollars

Why let that old-fashioned faucet go on year after year wasting water—MONEY? Why more drinking cups and glasses, only to become unsanitary—lost, broken or carried away? Puro Sanitary Drinking Fountain stops all this needless waste. Puro saves you 35% on the water bill alone. Puro saves you all that money you spend for cups. YET Puro is always ready with a clear, cool drink with dollars in the bank.

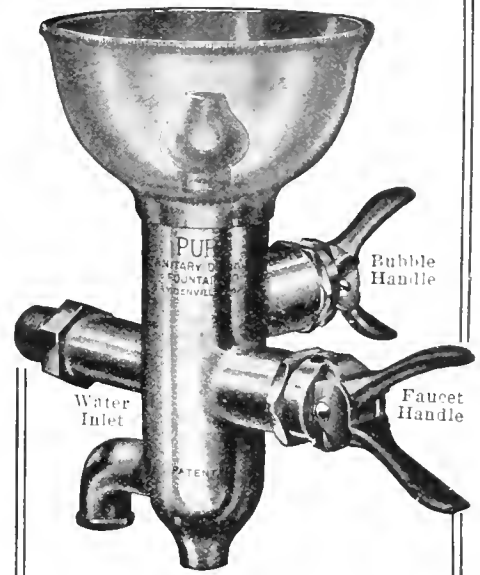

Puro Pays for Itself

You don't have to wait years to get back the small investment you have tied up in Puro equipment— You start cashing in at once not only on your water bill saving, but on the increased efficiency of your workers as well. Men like Puro it's clean. No danger of deadly germs lurking in its sparkling bubble. Write us—tell how many men, how many departments, and we'll tell you how much the cost will be to

"PURO - FY"

YOUR WATER SUPPLY

Puro Sanitary Drinking Fountain Company
147 University Ave., Toronto, Canada

OVENS

Enameling and Varnishing Ovens heated by Gas, Electricity, Steam or Coal. Write for Booklet.

Brantford Oven & Rack Co., Ltd.
Brantford, Canada.

Cameron Babbitt Retainer

(Patented in Canada and the U.S.A.)

Not like clay or other material, as it does not stick to the work or hands. Does away with using leather or paste-board at end of box.

The only satisfactory compound for retaining molten metal and can be used over and over again for months—no deterioration.

For any metal.

For prices and samples apply to

A.S.K. Chemical Company, Elora, Ontario

THE IRON WORKS
LIMITED

Successors to

Owen Sound Iron Works
Owen Sound, Ont.
Engineers
Boiler-makers
Founders
Machinists

Tank Work
Smoke Stacks,
Grey Iron and
Brass Castings,
Special
Machinery
Made to
Order

Hamilton Cotton Co., has been incorporated with a capital of \$1,000,000 at Ottawa to carry on the business of cotton and flax spinners and linen manufacturers at Hamilton, Ont. The incorporators are A. V. Young, J. V. Young and William Armstrong all of Hamilton.

Shipbuilders' Corporation Ltd., has been incorporated with a capital of \$250,000 to construct ships, tugs, lighters, etc., of every description. The head office of the company is at Toronto and the incorporators are Gerard Ruel, Reginald H. M. Temple and R. G. O. Thomson all of Toronto.

Russian Platinum Production.—According to the British Consul at Ekaterinburg, Russia, the 1916 output of platinum in the Urals amounted to 86,500 troy ounces, only about three-fourths of the output in 1915. The chief causes of the decline in the production of platinum are the shortage of labor, the difficulty in obtaining spare parts for dredges, and the exhaustion of the richer alluvial deposits. New alluvia will undoubtedly be found when extensive prospecting is resumed.

Russia's Car Orders.—Russia's Car requirements, which have been talked of for over a year, are given a better standing by the American Government's loan to Russia. Car builders, according to the *Iron Age*, now expect the orders will be for 10,000 to 20,000 cars of 40,000 pounds capacity. Domestic car orders of the week amounting to 1,500 and 2,000 cars have been placed in Canada. New locomotive contracts total 500, and the two leading builders are well booked for months ahead.

Record Zinc Output by Smelters.—Advices have been received in Toronto from the Trail Smelter of the Consolidated Mining & Smelting Co. of Canada that the zinc refinery output has risen within the past few days to a new high record at 89,000 pounds, or equivalent to about 44½ tons. Last week a new record was created with an output of 83,000 pounds which has now been displaced. This development which is highly satisfactory to the board of directors, and should be to the shareholders, compares with a contemplated maximum output of 25 to 30 tons per day when the company undertook the production of zinc by electrolytic process.

Metal Market in New Zealand.—According to the latest published report, the metal market in New Zealand is very greatly restricted for lack of supplies, although there is not the demand for metals in general that obtained before the outbreak of the war. Building and public improvements have been curtailed materially during the past three years. There has been a fair demand for fencing and barbed wire, however, and the supply has become almost entirely exhausted. One firm reported late sales amounting to 180 tons of fencing and barbed wire received from manufacturers in the United States. This demand is liable to continue until the close of the war.

Purchasing Pool for Allies.—A Washington dispatch says that a program under which the American Government virtually would pool its purchasing for the sake of attaining maximum efficiency, with that of all the Allies, construct a buying machine into which hundreds of experts in many lines would fit as cog wheels, and place one man in charge of the whole gigantic enterprise, is under consideration and fast assuming definite outline. This man would be the world's super-buyer. Into his hands the nations at war with Germany would place approximately \$10,000,000,000 a year, a store of money with no parallel in modern history. To assist this bureau head there would be an army of expert buyers

"Barnes-made" SPRINGS



are the result of over sixty years' experience in spring making, combined with unsurpassed equipment and the workmanship of men who have been with us, ten, twenty and in some cases thirty years.

Write for booklet No. 7-T.

Established 1857.
THE WALLACE BARNES COMPANY
218 South St., Bristol, Ct., U.S.A.
Mfrs of "Barnes-made" Products
Springs, Screw Machine Products, Cold Rolled Steel and Wire

RAILWAYS—BRIDGES

Toronto, Ont.—Manager Fleming of the Toronto Street Railway Co., has stated that an order has been placed for 100 new street car trucks, to be delivered before the end of this year. This is to fulfil the order of the Ontario Railway Board to provide 100 new cars this year and 100 next year.

TRADE GOSSIP

Winnipeg, Man.—The Swift Canadian Co., will extend their packing house here at a cost of \$5,000.

Winnipeg, Man.—The Canadian Bag Co., will build an addition to their factory here to cost \$31,000.

The Prest-O-Lite Co., Inc., have removed their Canadian general offices from Merritton, Ont., to the C. P. R. Bldg., Toronto. Cylinders are still being received and refilled at, and shipped from, Merritton, but all the general business of the company will be conducted from Toronto.

U.S. Steel Corp. to Build Shipyards.—The United States Steel Corporation has purchased a big acreage near Newark, in the New Jersey meadows, within a short distance of deep water, and will erect immediately a large shipyard where standard 8,000 and 10,000 ton steel ships will be constructed, probably with the co-operation of the Government Shipping Board.

Government Railways Mileage.—A big mileage is now under Government ownership and operation. The Transcontinental has 2,009 miles; Intercolonial, 1,562; Prince Edward Island Railway, 275; St. John Valley Railway, 205; and the International Railway of New Brunswick, 112 miles. This makes a total of 4,163 miles operated by the Dominion Government.

The Canadian Car and Foundry Co. has closed an order with the Canadian Government Railways for one thousand freight cars and work on the order will be commenced at once. At the Lachine plant, at the present time one thousand cars for the French Government have just been completed and the first shipment will be made in the next few days, besides this, two thousand cars are under construction for the Russian Government.



The "Dupont" PATENT Power Hammer

The strength, durability, economy of power and simplicity of adjustment of the Dupont Power Hammer make it a decidedly superior tool.

Made carefully from carefully selected, high-class materials.

Positively Guaranteed

Seven sizes.

With rams from 35 to 300 lbs.

Write for full details.

THE PLESSISVILLE FOUNDRY

Plessisville, Que.

Ontario and Western Agents:
The General Supply Co. of Canada Ltd
Ottawa Toronto Winnipeg

familiar with the American markets, and selected for their ability.

Trade Increase For April.—Canada's trade during the month of April totalled \$57,320,000. Hon. J. D. Reid, the Minister of Customs, announced recently. The figure for the same month of 1916 was \$106,585,000. There were considerable increases both in exports and in imports. The exports of domestic products reached \$65,145,000, or \$10,000,000 more than in April of last year, and included: Manufactures, \$40,000,000; agricultural products, \$11,000,000; food products such as meats, \$5,500,000; minerals, \$3,800,000; lumber, \$2,500,000. Imports amounted to \$86,000,000, comprising \$42,000,000 worth of goods, admitted free of duty and \$44,000,000 worth of dutiable goods. The sum collected in customs duties was \$13,875,000, as compared with \$9,000,000 in April, 1916.

Record Demand for Steel Predicted.—Manufacturers who were present at the meeting of the American Iron & Steel Institute recently in New York were all of one opinion—that while capacity was larger than ever before, the demand was also record-breaking, and that the wants of consumers this year could not be satisfied. One of the largest subsidiaries of the U.S. Steel Corporation has notified consumers that it can make no further contracts until 50 per cent. of the orders now on the books are worked off. Many consumers want to buy steel for delivery as far forward as 1919. The steel companies will be the heaviest war tax payers this year, and the incomes of shareholders will be greatly increased. This will mean additional revenue for the Government. Steel manufacturers have been assured that nothing will be done in the way of price fixing for Government needs that will disturb their business in the least.

To Develop Canada's Fuel Supplies.—A resolution was adopted in the House at Ottawa recently reading as follows: "That in the opinion of this House, it is of great importance that the increasing demand for fuel for manufacturing and residential purposes be supplied in larger quantities and at cheaper rates than are now possible; that the deposits of bituminous and anthracite coal in Canada, located in the extreme eastern and western portions thereof, be more fully and thoroughly utilized for the benefit of the residents of the central Provinces; that the enormous peat and lignite deposits so widely distributed through all portions of the Dominion be also scientifically made use of for the same purpose, and further, that the Government of Canada make a special effort, through legislation and otherwise, to have these valuable deposits more fully and rapidly developed, to the end, that the people of Canada may be adequately provided with these fuels for industrial and residential purposes."

Wooden Ships for B.C.—The following is a description of the vessels that will be built in British Columbia, in an official statement issued by the Imperial

WM. MUIR & CO., LIMITED
 Manchester, England.
 Machine Tool Makers.
 Specialties: Patent Puncher Slotting Machines, Milling Machines, Boring Machines.
 Agents: Messrs. Peacock Bros., 68 Beaver Hall Hill, Montreal.
 Send for catalogue.

JOHN STIRK & SONS, Limited
 HALIFAX, ENG.
MACHINE TOOLS
 Agents—The A. R. Williams Mty. Co., Ltd.
 Toronto, Winnipeg, Vancouver, St. John, N.B.

BERTRAMS LIMITED
 Engineers
 Sciennes, EDINBURGH
 PAPER MILL MACHINERY
 and
 MACHINE TOOLS FOR IRON WORKERS
 Catalogues offered to Purchasers.

WIRE SPRINGS
 OF ALL KINDS
 Machine Springs, Valve Springs, Automobile Cushion Springs, etc., of a quality that defies competition. Tell us your requirements. Send sample or specification for price.
JAMES STEELE, LIMITED
 GUELPH, ONTARIO

Quality is Highest—Not the Price
Dickow's Guaranteed 10-Inch Universal Index Centers
 You save from \$50 to \$125 on first cost, and many times that because of their simple construction and great ease of operation. They embody the maximum of accuracy, simplicity and durability.

 Get the Original—Beware of Imitators
 Sold by all dealers. Write to-day for particulars
 Fred. C. Dickow, 35 So. Desplaines St., Chicago, Ill., U.S.A.

Oil Tempered Steel Springs
 —for every purpose and the best for each use.
 Special styles of all kinds to order.
THE CLEVELAND WIRE SPRING COMPANY
 Cleveland, Ohio
 U.S.A.

BOLTS
 Our large stock of Machine Bolts, Rivets and Washers assures quickly filled orders and prompt shipment. One quality only—The Best.
 Send a trial order.
LONDON BOLT & HINGE WORKS
 London Ontario

Special Machinery
 MADE TO ORDER
 Mill Machinery, Engine Work
 Grey Iron and Brass Castings
 TRY US FOR GENERAL REPAIRS
ALEXANDER FLECK, LIMITED
 (Vulcan Iron Works) OTTAWA, ONT.

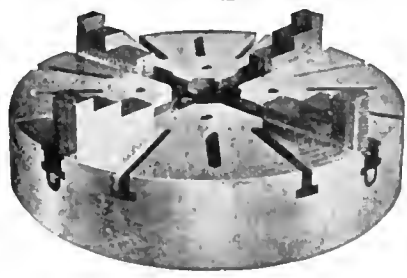
We Know
 you are anxious to buy
Canadian Made
 goods.
The Imperial

Chuck
 is manufactured by
Ker & Goodwin
 Brantford, Canada

PATENT ATTORNEYS

BABCOCK & SONS

ESTAB. 1872.

PATENTS-TRADE MARK-DESIGNS
IN ALL COUNTRIES

Book "Patent Protection"—free. Master of Patent Laws, Formerly Patent Office Examiner.

99 St. James St., - Montreal, Que.
Branches: Ottawa, Washington.

RESEARCH BUREAU

REPORTS BY EXPERTS ON SCIENTIFIC, TECHNICAL AND INDUSTRIAL DEVELOPMENT.

SPECIAL RESEARCHES ARRANGED.

PATENTS, TRADE MARKS, ETC.

HANBURY A. BUDDEN CABLE ADDRESS
712 DRUMMOND BLDG., MONTREAL "EREVEY"

PATENTS

Fetherstonhaugh & Co.,
Patent Solicitors, Head Office,
Royal Bank Bldg., Toronto,
Ottawa Office, 5 Elgin St.
Send for our Plain Practical
Pointers. Copy of National
Progress, in which our patents
are advertised, mailed free.

PATENTS PROMPTLY SECURED

In all countries. Ask for our Investor's Adviser, which will be sent free.

MARION & MARION 364 University St.
Merchants Bank Building, corner
St. Catherine St., MONTREAL, Phone Up. 6474
and Washington, D.C., U.S.A.

MORTON MANUFACTURING CO.

PORTABLE PLANERS
DRAW CUT SHAPERS
SPECIAL DRAW CUT R.R. SHAPERS
FINISHED MACHINE KEYS
STATIONARY & PORTABLE KEY WAY CUTTERS
SPECIAL LOCOMOTIVE CYLINDER PLANERS
OFFICE AND WORKS: MUSKEGON HEIGHTS U.S.A.

MAPLE LEAF

STITCHED COTTON DUCK

BELTING

DOMINION BELTING CO. LTD.

HAMILTON CANADA

Munitions Board's representatives: 250 feet long, 43 feet 6 inches beam and 25 feet deep, with a dead weight capacity of about 2,800 tons on a draft of 21 feet. The vessels are to be built very strongly with box girder keelsons. They have a deep tank forward for water ballast. They are to be propelled by steam with triple-expansion engines of about 950 indicated horse-power. The matter of geared turbines from England is being considered for some of the ships. The vessels are to be built of Douglas fir to Lloyd's requirements for A1 classification. The system under which these vessels are to be built is as follows: The builder provides the shipyard and equipment; the board supplies standard plans and specifications, provides for a supply of all materials and for the machinery, and pays the contractor a stated margin of profit over actual cost of building. A uniform scale of wages.

CATALOGUES

Cooling Water For Ice Plants.—Bulletin dealing with economy cooling circulation water for ammonia or steam condensers by the method of spraying. Issued by the Spray Engineering Co., Boston, Mass.

Electric Tools.—The Stow Manufacturing Co., Binghampton, N.Y., have issued two new miniature bulletins Nos. 101 and 102 dealing with their line of electric tools and flexible shafts. They have been issued in addition to the regular bulletins and are a distinct novelty owing to the small size and completeness of detail.

A Treatise on Milling and Milling Machines, published by the Cincinnati Milling Machine Co., Cincinnati, Ohio.—The idea of publishing this treatise was to place in the hands of those interested in and responsible for efficient production on milling machines, a more complete knowledge of the action of milling machines and the construction of different types of milling fixtures and holding devices, etc. The company have carried out some very exhaustive experiments in cutter designs, cutter and work cooling and other features which have led to marked improvement in the operation and design of milling machines. These developments have been compiled in complete form, in this book, and being in one volume will be more easily followed, and thus of greater service to the milling machine operator. A more complete knowledge of the action of milling cutting, a familiarity with different constructions and types of milling fixtures, the cause of unsatisfactory milling machine performance, etc., are all necessary for the intelligent operation of the present day milling machine. Considerable space has been devoted, in the 21 chapters which the book contains, to the various phases of these subjects, and new matter, never before published, has been included. The book contains 469 pages and 268 illustrations, while in addition there are a large number of rules, formulae and tables which will be extremely useful for the milling machine operator.

GAUGES

DIES, TOOLS AND REPAIRS
OXY-ACETYLENE WELDING

WORTH ENGINEERING CO.

163 Spadina Ave., Toronto, Ont.
Phone Adel. 3734

B. H. AYLSWORTH A. E. HACKWORTH

Oxy-Acetylene Welding

We can give the best of service in all kinds of welding repair jobs. We have successfully repaired the most difficult jobs. Our work is high-class and our prices moderate.

Send us your work or write us regarding it.

TORONTO WELDING CO.
26 Pearl St., TORONTO

ON PAGE 70

You'll find a host
of Opportunities.

TURN TO IT!

METAL STAMPINGS

We are manufacturers of stamped parts for other manufacturers.

We do any kind of sheet metal stamping that you require. Our improved presses and plating plant enable us to produce the finest quality of work in a surprisingly short time.

We can finish steel stamping in Nickel, Brass or Copper.

Send us a sample order.

W. H. BANFIELD & SONS

372 Pape Avenue, Toronto, Can.

CANADIAN MACHINERY

AND MANUFACTURING NEWS

A weekly newspaper devoted to the machinery and manufacturing interests.

Vol. XVII.

TORONTO, JUNE 7, 1917

No. 23

EDITORIAL CONTENTS

The Dominion Forge & Stamping Co., Walkerville, Ont.	579-583
General	583-584
Future Supplies of Iron Ore....Canada's 1916 Steel Output....Water Gas Practice.	
A Foundation for Machine Tool Design and Construction	585-588
General	588
G.T.R. Stratford Shops Apprentices Maintain Their Past Record.	
Development of Ocean Service Shipbuilding in Canada—IV	589-591
S.S. "War Dog" Launched at North Vancouver.	
Accident Prevention in Shipyards	591-594
General	594
Heligoland....Lachine Canal Traffic During May.	
Spokes in Industry's Wheel	595-596
Walter Lambert.	
General	596
Canada's Shipbuilding Prosperity....U.S. Steel Corporation to Build Canal Barges.	
Production Methods and Devices	597-598
Special Wave and Groove Machine....Press Tools for Metal Clips....Boring and Reaming Line Holes.	
The "Howden" Sectional Type, Water Tube Steam Boiler	599-602
General	602
Ball Bearings in the Woodworking Industry.	
Editorial Correspondence	603-605
Machinists' Instruction Course XXI....Material and Mechanism....How the Moving Picture Film Gets its Motion....The Fuel Value of Pitch.	
Editorial	606
Plant Reference Library....Efficiency Through Co-operation.	
Industrial Notabilities	607
William Evelyn Vallance.	
Selected Market Quotations	608-609
The General Market Condition and Tendency	609-614
Summary....Montreal Letter...Pittsburgh Letter....Hydro-Electric Buys Out Ontario Power Co....Instructions to Lake Mariners....Coke Fuel for Power Stations....Ship Seized in Harbor....Dominion Steel Corporation Output.	
Industrial and Construction News	78-85

THE MACLEAN PUBLISHING COMPANY, LIMITED

JOHN BAYNE MACLEAN, Pres. H. T. HUNTER, Vice-pres. H. V. TYRRELL, Gen. Man.

Publishers of Hardware and Metal, The Financial Post, MacLean's Magazine, Farmer's Magazine, Canadian Grocer, Dry Goods Review, Men's Wear Review, Printer and Publisher, Bookseller and Stationer, Canadian Machinery and Manufacturing News, The Power House, The Sanitary Engineer, Canadian Foundryman, Marine Marine Engineering of Canada.

Cable Address: Macpubco, Toronto; Atabek, London, Eng.

ESTABLISHED 1887

CANADIAN MACHINERY

AND MANUFACTURING NEWS

PETER BAIN, M.E., Editor. R. G. NEWTON, Manager.
Associate Editors: A. G. WEBSTER, J. M. WILSON, J. H. RODGERS.

CHIEF OFFICES:

CANADA Montreal, Southam Building, 128 Bleury Street, Telephone 1001; Toronto, 143-153 University Ave., Telephone Main 7324; Winnipeg, 22 Royal Bank Building, Telephone Garry 2313.

GREAT BRITAIN LONDON, The MacLenn Company of Great Britain, Limited, 88 Fleet Street, E.C. E. J. Dodd, Director. Telephone Central 12960. Cable Address: Atabek, London, England.

UNITED STATES New York, R. R. Huestis, Room 620, 111 Broadway, N.Y., Telephone Rector 8971; Boston, C. L. Morton, Room 733, Old South Building, Telephone Main 1204. A. H. Byrne, 1104-5-6-7 Fort Dearborn Bldg., 105 W. Monroe St., Chicago, Telephone Randolph 3236.

SUBSCRIPTION PRICE Canada, Great Britain, South Africa and the West Indies, \$3.00 a year; United States, \$3.50 a year; other countries, \$4.00 a year; Single Copies, 15 cent. Invariably in advance.

If there is one machine more than another where

Absolute Accuracy

is required, it is in the construction of an Experimental Lathe.

Accurate fitting, assembling, aligning of head and tailstock and carriage with lathe bed, is found without exception in the "Hendey."

Motor-driven. Besides regular equipment it has small tool cabinet for operators' fine tools—also gear closet for extra gears to cut special threads.

Let us tell you more about it.

The
Hendey Machine Co.
Torrington, Conn., U.S.A.

Canadian Agents: A. R. Williams Machinery Co., Toronto, Ont.; A. R. Williams Machinery Co., 260 Princess St., Winnipeg; A. R. Williams Machinery Co., Vancouver; A. R. Williams Machinery Co., St. John, N.B.; Williams & Wilson, Montreal.

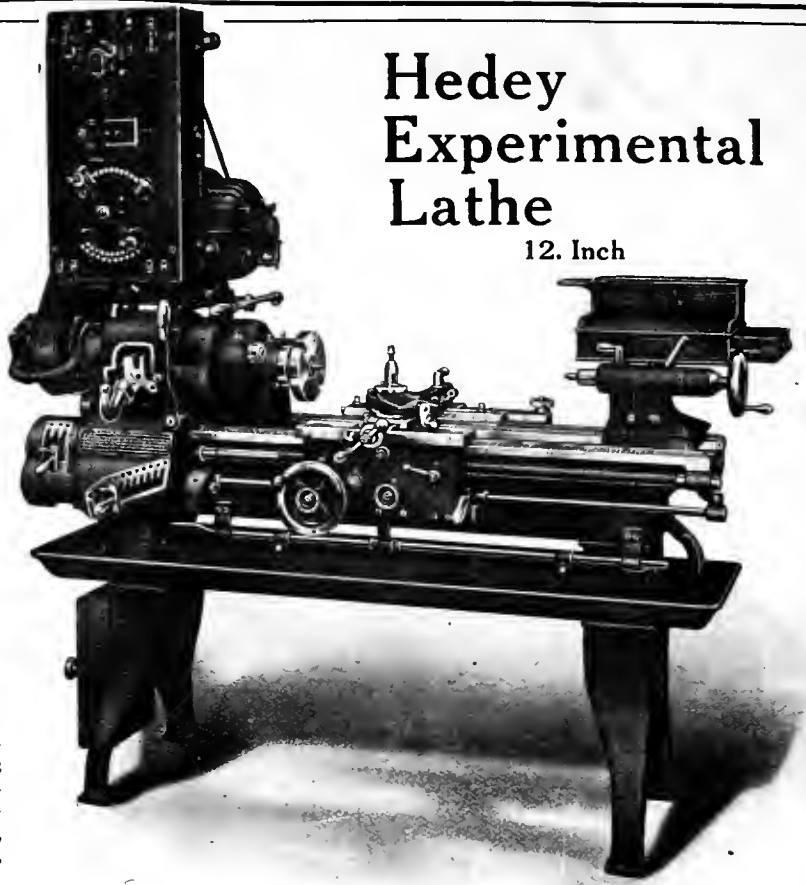

Hedey Experimental Lathe

12. Inch

INDEX TO ADVERTISERS

A	
Acme Mach. Co.	5
Adams, Ogden R.	158
American Pulley Co.	114
Armstrong Bros. Tool Co.	159
Armstrong, Whitworth of Canada.	5
A. S. K. Chemical Co.	81
Atlas Press Co.	31
Atkins, Wm., & Co., Ltd.	17
B	
Babcock & Sons	81
Baird Machine Co.	159
Bainfield, E. J.	20
Bainfield, W. H., & Sons	39
Barnes, Wallace, Co.	82
Bath, Cyril J.	90
Baxter & Co., Ltd., J. R.	95
Beatty & Son, M.	11
Bellevue Industrial Furnace Co.	110
Bertram, John, & Sons Co., Ltd.	1
Bilton Mach. Tool Co.	153
Blackall, Fred S.	123
Blake & Johnson Co.	143
Blake Pump & Condenser Co.	28
Blount, J. G.	140
Bramford Oven & Rack Co.	5
Bridgford Mach. & Tool Works	5
Bristol Company	157
Brownell Machy. Co.	89
Brown, Boggs Co.	11
Brown's Copper & Brass Rolling Mills	39
Budden, Hambury A.	89
C	
Canada Metal Co.	153
Can. Bond Hanger & Coupling Co.	117
Canada Machinery Corporation	Outside back cover
Can. B. K. Morton Co.	19
Can. Bridge Co., Ltd.	91
Can. Fairbanks-Morse Co.	38
Can. Desmond-Stephan Mfg. Co.	153
Can. Economic Lubricant Co.	105
Can. Hanson & Van Winkle Co.	171
Can. Haskins, Ltd.	110
Can. Ingersoll-Rand Co., Ltd.	140
Can. Inspection & Testing Laboratories, Ltd.	157
Can. Mathews Gravity Carrier Co.	85
Can. Metal Products	94
Can. Morehead Mfg. Co.	129
Can. Steel Foundries, Ltd.	7
Can. S. K. F. Co., Ltd.	26
Carborundum Co.	144
Chas. E. Johnson Mach. Co.	8
Chas. Welling Co.	104

Chapman Double Ball Bearing Co.	119
Cincinnati Electrical Tool Co.	157
Cincinnati Milling Mach. Co.	123
Cincinnati Pulley Machy. Co.	165
Clark Equipment Co.	98
Cleveland Milling Mach. Co.	129
Cleveland Pneumatic Tool Co.	128
Cleveland Twist Drill Co.	163
Clippier Belt Lacer Co.	118
Commercial Acetylene Welding Co.	102
Commercial Canada Co.	100
Consolidated Press Co.	169
Cook, Asa S.	97
Cullen Machy. Co., C. W.	15
Cummings & Son, Ltd., J. W.	15
Curtis & Curtis Co.	157
Curtis Pneumatic Mach. Co.	117
Cushman Chuck Co.	157
D	
Davis-Bannanville Co.	164
Davis, W. F., Machine Tool Co.	5
DeLong Smelting & Refining Co.	4
De Mooy Mach. Co.	129
Detroit Pneumatic Chuck Co.	151
Dillon Mfg. Co.	106
Diamond Saw & Stamping Works.	128
Dominion Forge & Stamping	32
Dominion Machinery Co.	89
Dominion Steel Foundry Co.	157
Drom Co., H. A.	7
E	
Eastern Mach. Screw Corp.	157
Elmes, Chas. F.	122
Eme Foundry Co.	122
F	
Fairley, Davidson Steel Co.	11
Fetherstonhaugh & Co.	8
Fitching Grinding & Mach. Co.	145
Fitzgerald, W. H. J.	90
Fowl-smith Mach. Co.	26
Foster Michy. Co.	127
Foss & Hill Machy. Co.	Inside back cover
Fox Mach. Co.	134
Francis & Co.	159
G	
Gardner Machine Co.	144
Garlock-Walker Machy. Co.	146
Garvin Machine Co.	146
Geometric Tool Co.	77
Gibbs Instrument Co.	111
Gilbert & Barker Mfg. Co.	173
Gilchrist Tool Co.	150

Goodell-Pratt Co.	106
Grant Gear Works, Inc.	158
Grant Mfg. & Machine Co.	105
Graton & Knight Mfg. Co.	117
Gray-Dort Mfg. & Mach. Co.	124, 125
Gray Motors, Ltd.	88
Greenfield Machine Co.	140
H	
Hamilton Gear & Machine Co.	94
Hamilton Machine Tool Works	131
Hanna & Co., M. A.	2
Hardinge Bros.	23
Hawkrige Bros.	22
Hendey Machine Co.	158
Henry & Wright Mfg. Co.	169
Hoburn, John T.	14
High Speed Hammer Co.	117
Himelf Mach. Co.	159
Houston, Stauwood & Gamble Co.	126
Hovt Metal Co.	160
Hull Iron & Steel Fabrics, Ltd.	27
Hunzford Brass & Copper Co.	107
Hurlbot-Rogers Machinery Co.	150
Hyde Engineering Works	13, 95
I	
Ideal Tool & Mfg. Co.	152
Illinois Tool Works	70
Independent Pneumatic Tool Co.	140
Iron Works, The	24
J	
Jacobs Mfg. Co.	155
Jenckes Mach. Co.	9
Johson, Geo. E.	85
Johnson Mach. Co., Carlyle	9
Jones & Glass	115
K	
Kemp-smith Mfg. Co.	151
Kennedy, Wm., & Sons	20
Kidston Co., A. G.	3
King, Ltd., Warden	20
L	
L Air Liquide Society	162
Landis Machine Co.	158
Lancashire Dynamo & Motor Co.	106
Lindsay Electric Steel Co.	18
L. H. H. Mach. Tool Co.	12
Land-Faular Co.	89, 128
M	
MacKinnon, Holmes & Co., Ltd.	30

Manufacturers Equipment Co.	152
Marion & Marion	81
Marsh & Henthorn, Ltd.	143
Martin Mach. Co.	32
Matthews, Jas. H., & Co., Inc.	38
McAvity & Sons, T.	88
McCabe, J. J.	30
McCoy-Brandt Machy. Co.	91
McDougall Co., H.	Inside back cover
McLaren, J. C., Helting Co.	158
Mechanical Engineering Co.	111
Metal Manufacturers' Service	94
Metalwood Mfg. Co.	122
Millers Falls Co.	156
Modern Tool Co.	150
Monarch Brass Mfg. Co.	95
Montreal Machy. & Supplies.	163
Morse Twist Drill & Mach. Co.	105
Morton Mfg. Co.	81
Murchev Machine & Tool Co.	154
N	
Napier Saw Works, Inc.	139
National Veneer Co.	153
National Electric Welder Co.	103
National Machine Tool Co.	159
New Britain Mach. Co.	25
New York Machinery Exchange	92
Nicholson File	142
Niles Cement-Pond.	Inside front cover
Noble & Westbrook	160
Northern Crane Works	116
Norton, A. O.	158
Norton Co.	36
Norton Grinding Co.	37
Nova Scotia Steel & Coal Co.	16
O	
Ontario Specialties, Ltd.	157
Oven Equipment & Mfg. Co.	106
Oliver Machy. Co.	15
P	
Painter & Bulloch Co.	160
Pack Stow & Wilcox Co.	148
Peerless Machine Co.	156
Perrin, Wm. R.	122
Petrie of Montreal, H. W.	87
Petrie, H. W., Ltd.	87
Pitt Hope File Mfg. Co.	157
Positive Chuck & Pulley Works.	159
Pratt & Whitney.	Inside front cover
Price Electric Co.	85
Pringle, R. E. T., Ltd.	31
Puro Sanitary Drink'g Fountain Co.	34

The Dominion Forge & Stamping Co Limited.

Walkerville, Ont.

Staff Article



Next to the production of iron and steel from the raw ore, the field of operation covered by stamping and forging is of greatest, though not always most obvious importance. Recent events have tended to thrust machine shop work more into the limelight, but as a basic branch of engineering activity the art of stamping and drop forging may be expected to increase in importance as conditions revert to normal in the hoped-for near future.

NEXT to the production of raw material, the working of it into a semi-finished state suited for consumption by manufacturing plants, is perhaps the most important step in its progress toward the final consumer. Because of the nature of the work, and conditions of the business, drop-forging and stamping, to be successfully carried on, must be conducted with a degree of efficiency, both from an economic and productive point of view, exceeding that which is permissible in ordinary metal-working establishments. Occupying as it does, an intermediate stage between the initial and final stages of manufacture, the functions of a plant such as described in this article, must be discharged systematically and reliably, otherwise the successful operation of other plants dependent on its product may be seriously jeopardized. The growth of drop-forging and stamping work in this country has been steady and continuous over a number of years, and the magnitude of operations and extent of equipment installed serve to convey some idea of the important part played by firms of this type

Plant Locations

The Dominion Forge & Stamp Co., Walkerville, Ont., operates two plants. The original plant, No. 1, adjoins the Grand Trunk Railway near Walkerville station and occupies the entire end of the block between St. Luke's Road and Albert Street. Both forging and stamping operations were carried on here until in-

creased business made imperative the separation of the two branches, and accordingly a complete new forge shop was erected, being known as plant No. 2. It is also in Walkerville, on the line of the Pere Marquette Railroad, with office entrance on Seminole street.

Plant No. 1 is therefore entirely employed in the production of stampings and cold press work. Nearly all of the stamping work is in connection with the automobile business and consists of sheet metal fenders, tanks, mufflers and hoods. Some time ago, operations were extended to include the manufacture of automobile frames, and developments in this line have been such that arrangements are now being made to double the shop capacity for this product. Frame production is carried on in a separate building on the opposite side of Albert street, an interior view of this building forming one of the illustrations. Situated here is also the boiler house which was necessary for the original force department before removal to plant No. 2, and which is now used for the central

floors with basement and is of reinforced concrete construction with large lighting areas on all sides. It is 55 feet wide by 157 feet long. Extending to the rear is the tool room building, of single floor construction, connecting with the fender forming department. This latter department is parallel with the main building, and can be seen in illustration on page 580, where the monitor roof shows above the tool room.

Press Room

The basement is devoted entirely to storage of raw material, many tons of sheet metal of various sizes and gauges being kept in stock, although present conditions of the steel industry and heavy demands for product have prevented any extensive accumulation of material. The first floor contains the receiving and shipping department with elevator service to all floors. All heavy stamping work such as blanking, flanging, etc., involving the use of large machines is done on this floor, a view of some of the larger presses being given

on page 580. Five large double-crank presses are employed for blanking and forming sheets for automobile fenders, of which several types are made; flanging and embossing or doming over large areas is also done in these presses. Two of these large presses are shown toward the right of illustration. Additional equipment on this floor includes medium power presses and shears. Prominent amongst the makers of these machines

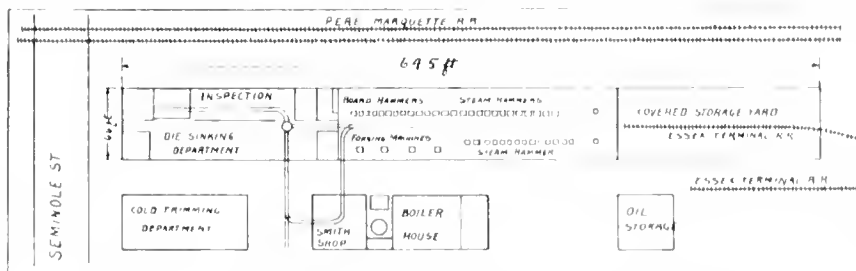

PLAN VIEW OF FORGE PLANT SHOWING LAYOUT OF DEPARTMENTS

heating plant for the stamping division.

Stamping Plant

The main building consists of four

are noted, the Toledo Machine & Tool Co., and the Consolidated Press & tool Co.

Fender Forming

Following the fender blanks to the forming department, the operations necessary to complete the crowning are done in a large double-crank press, after which the aprons, skirts, or fillers, as they are variously termed, are united with the fender proper by means of rolling and beading, these operations being done on special types of sheet metal working machinery. Some slight amount of hand work is necessary to remove variations in shape and any irregularities which occasionally appear, due to slight variations in the material being operated on.

Miscellaneous Assembly

Returning to the second floor of the main building—this is occupied with the assembling of muffler parts, engine hoods, tanks, etc., the equipment consisting of presses, shears, etc., such as are ordinarily used for such work. The third floor is occupied by the fender finishing department, which includes the fitting of reinforcements at different parts of the fenders, and the securing in place of various details either by beading and rolling or by electric welding. Final fitting by hand to duplicate fixtures representing the parts of the car frame, completes the work of fender making, which is followed by the enameling process before the fenders are complete and ready for shipment.

The locating of the enameling department on the fourth or top floor is desirable because of the freedom from the dust on the sheet, and the absence of annoyance to other floors by the presence of vapors and odors. The fenders are first of all cleaned with emery cloth after which they are washed in gasoline to remove all grease and foreign matter. The enamel is applied by dipping, the fenders being immersed in a large tank

of liquid enamel and hung up to drain thoroughly before baking. Several coats are applied according to specification, each coat being baked at a temper-

to the tool room squad on their own merits, as it is generally preferable to find a way of doing the work in a satisfactory manner, rather than spend the same

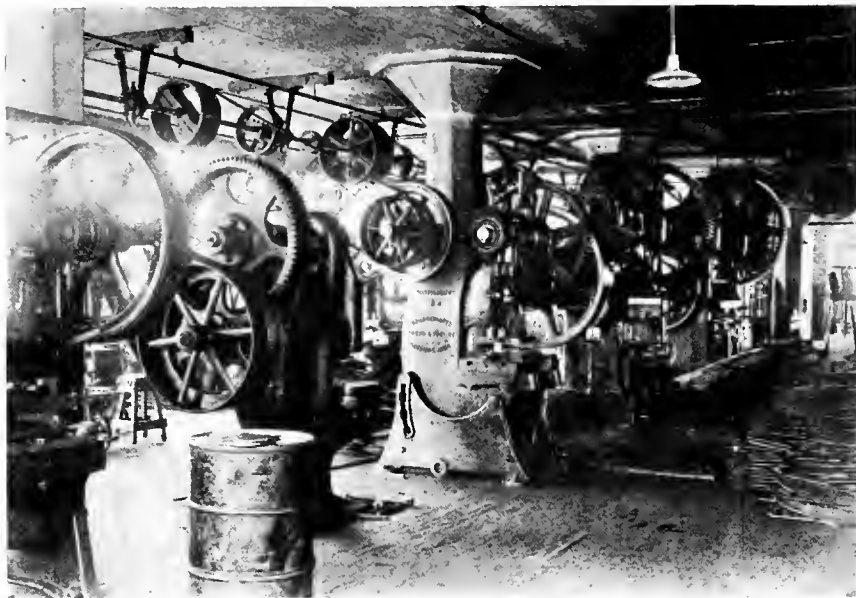

VIEW OF PRESS ROOM IN MAIN BUILDING, SHOWING TYPES OF MACHINES USED IN MAKING FENDERS.

ature of 350 deg. F., in order to obtain that hard glasslike finish which is such a conspicuous feature of modern automobiles.

Plant Maintenance

The construction and maintenance of stamping machine equipment calls for considerable experience in work of this class. The designing, building, and trying-out of a set of dies for a new design of fender is always a prolonged and expensive job. Methods which have been successfully applied in one shop may, for some unaccountable reason, fail to give satisfactory results in another, and the necessity of meeting the call for deliveries puts the job up

or longer time finding out why the other fellow's method will not work. It is not surprising, therefore, to note the extent of the tool room equipment, when one considers that, although the types of fenders produced are comparatively few, there are perhaps twelve to sixteen separate and distinct operations in each fender.

Prominent amongst the machines is a No. 6 vertical Becker milling machine, capable of handling a large variety of work in connection with the stamping dies. Three shaping machines are installed—C. M. C., Smith & Mills, and American Tool Works Co. Other machines include a large surface grinder for die-blocks, etc., built by the Safety Emery Wheel Co., a Le Blond tool room grinder, a Gray planer, and a Cataract bench lathe, the equipment being rounded out by such items as two milling machines (plain and universal), two sensitive, drills two vertical drill presses, one radial drill and three tool room lathes.

A blacksmith shop and heat-treating department are also provided, while a 9 x 8 in. motor driven Ingersoll-Rand compressor supplies high pressure air throughout the building.

Frame Manufacture

The frame shop, to which reference has already been made, is single floor brick building equipped for the quantity production of automobile frames. Operations at present are concentrated on two designs, the finished cars of which they are a part being two of the most popular makes in this country. Roughly speaking, the work of making a frame consists of shearing, trimming, punching, forming, assembling. The stock is received in sheets which are cut to the proper outline on a 12 ft. Nia-



MAIN BUILDING OF PLANT NO. 1, WHERE HEAD OFFICE OF COMPANY IS LOCATED.

gara shear. Special trimming work is now done on the ends if necessary, according to the type of frame being made. This work consists of shaping the ends so that projecting lugs may be bent sideways at a later stage to form angle brackets wherewith to facilitate the assembling of the cross members with the sides.

The strip from which the side is formed, still flat, is now taken to a multiple punching machine which punches every hole in the side simultaneously. The machine is of special design and is located in the left background of the frame shop (see photo below). It is of the inverted type, with the lower platen operated by three eccentrics located underneath, the eccentric shaft and driving motor being all below floor level, so that the platen is at a convenient height for the operators to handle material. Eight massive steel columns threaded at their upper ends, support the stationary platen and provide adjustment for the various dies. This press runs approximately 10 strokes per min., and punches from 60 to 80 holes, round, square, or oval, at one stroke.

After a sufficient number of parts have been punched, the machine is changed over to forming work and turns over the top and bottom flanges which impart the familiar U section to the piece. Various other presses to the number of fourteen have meanwhile been engaged in similar work on the cross members, some of which are shown on trucks in the view of the frame room. These are now grouped together and riveted, some of the riveting being done in punch presses cold and some of it by pneumatic hammers hot.

In this building is also located the welding department in which two Prestolite welding outfits are installed. Much of their work consists in welding muffler parts and special exhaust pipe sections. Another 9 x 8 in. Ingersoll-Rand compressor is installed here for the pneumatic apparatus.

Considerable as is the output of this department, the constant growth of demand from the ultimate consumer has rendered necessary the doubling of capacity, and active operations are now in

which pass through the cold trimming department, the great bulk of the work passes continuously from storage shed into forge shop, thence to inspection, and finally shipping.

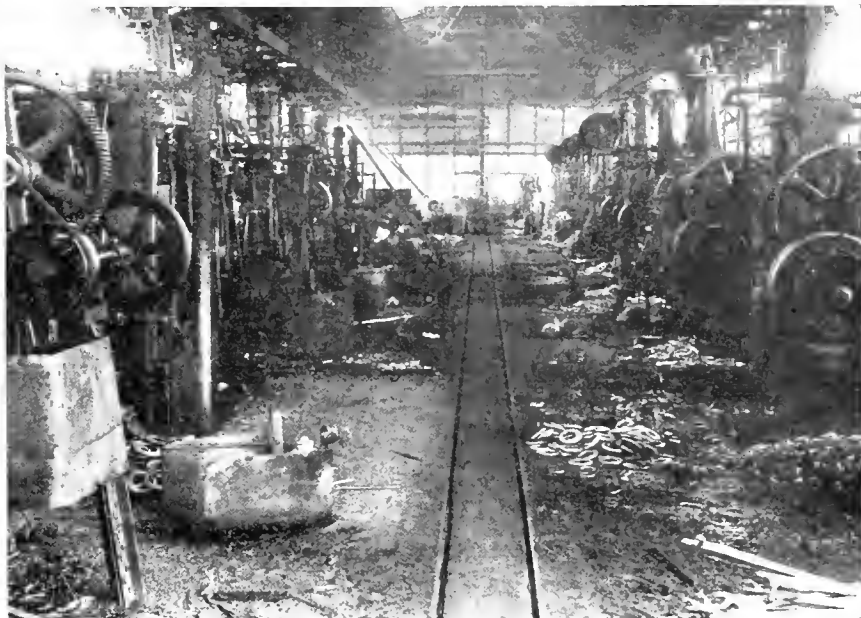

LOOKING DOWN THE CENTRE OF FORGE DEPARTMENT, PLANT NO. 2.

progress to duplicate the department, space being conveniently available at one end.

Forging Plant

The "Forge," as plant No. 2 is familiarly termed, is an excellent example of specialized plant design. While the conditions which prevailed in the original plant before the erection of these works delayed development of this line to some extent, it afforded desirable opportunity for studying the requirements and planning the arrangement of the new plant on the most efficient lines. The straight line design of plant has been adhered to in very complete degree, as with the exception of certain types of forgings

A study of the plant lay-out on page 579, combined with the title illustration, conveys a clear idea of the plant. The view forming the title is taken from Seminole street, just above the tracks, the forge shop occupying the main central portion of the building, with the steel storage shed showing at the far end. This shed is approximately 185 ft. long by 66 ft. wide, which is the uniform width of the main building. Both the storage shed and forge shop buildings are of considerable height in order to provide headway for a 5-ton Northern overhead traveling crane of 40 ft. span, which travels the full length of the two departments. A standard gauge spur track from the Essex Terminal Railroad extends the full length of the storage shed, so that incoming cars of raw material can be placed in close proximity to the particular section of storage space devoted to any certain class of material.

Routine of Operations

An industrial track system connects the various parts of the plant. Bundles of bar stock are deposited at the two Bertram bar shears, one on each side of the forge shop, where they are cut to the required length, while if no cutting is required, the traveling crane conveys the stock direct to the particular furnace, where it is to be forged. Passing along the forge shop, as shown in view above, on the right is a battery of Massillon steam hammers, consisting of four 1,500 lbs., and two of 2,500 lbs. capacity. The heavier sizes handle parts for railroad cars, such as draw-hooks, equalizing levers, spring shackles, etc. A number of motor car forgings are also produced at this point, steering knuckles, hand levers, etc., being prominent items. Immediately across the shop from

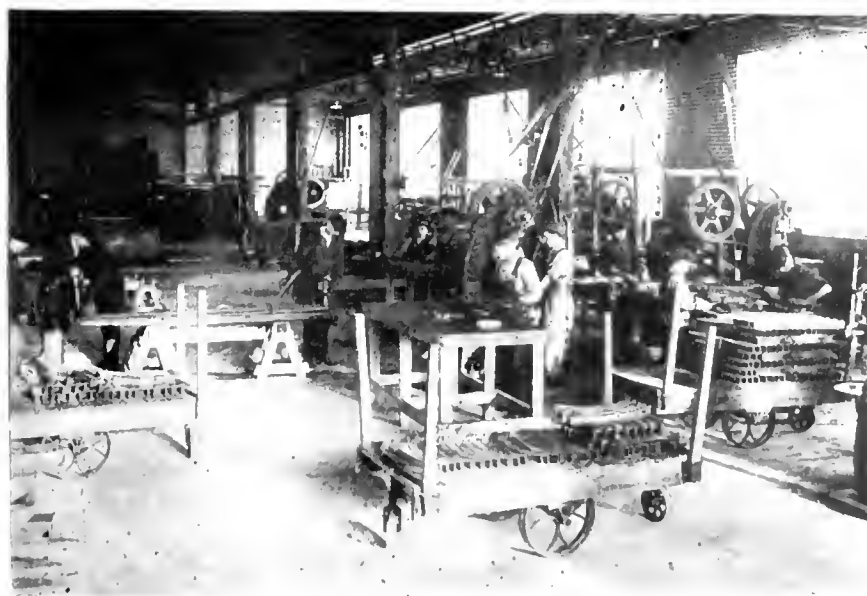

COMPONENT PARTS OF AUTOMOBILE FRAMES IN PROCESS OF MANUFACTURE IN FRAME DEPARTMENT.

these is a battery of eight hammers, one 5,000 lbs. Chambersburg, and seven Massillon hammers, 1 of 3,000 lbs., 4 of 1,200 lbs., and 2 of 800 lbs. Crankshafts for motor car engines, front axle forgings, and various pieces of similar proportions, are forged on the larger hammers, while small parts, such as forked rod-ends, steering levers, etc., constitute the bulk of work done on the four smaller hammers.

Beyond the hammers on the right are nine board hammers engaged on munitions stampings and similar work, including one 1,500 lbs. Toledo, and eight Waterburys, from 800 to 1,000 lbs.

Forging Machines

The blocking out of certain types of forgings before going to the hammer is frequently desirable, the ends of front axles being an instance of this work, which is performed on forging machines of the Ajax, Acme and National types, having capacities for handling stock from 1½ in. to 4 in. Individual motor drive is installed on these machines, their location being opposite the board hammers.

Cold Trimming

Where the size and type of forging render it desirable, provision is made for hot trimming in a suitable machine placed next the hammer, but much small work can be trimmed to advantage when cold. The economy of this is apparent when it is considered that cold trimming is limited only by the speed at which the operator can feed the machine, whereas hot trimming is limited to the speed at which the hammer finishes the work; in addition to which the class of help necessary for cold trimming is comparatively unskilled compared with that of a drop-forge operator. The location of the cold trim shop is indicated in the plan and a view of one side is shown below. The bins at left are built

with hopper bottoms, which cause the pieces to slide to the opening as quickly as they are withdrawn. An inclined runway extends from the yard to the

chine equipment in this department includes a set of Massillon shears, and two Newton motor-driven cold sawing machines.

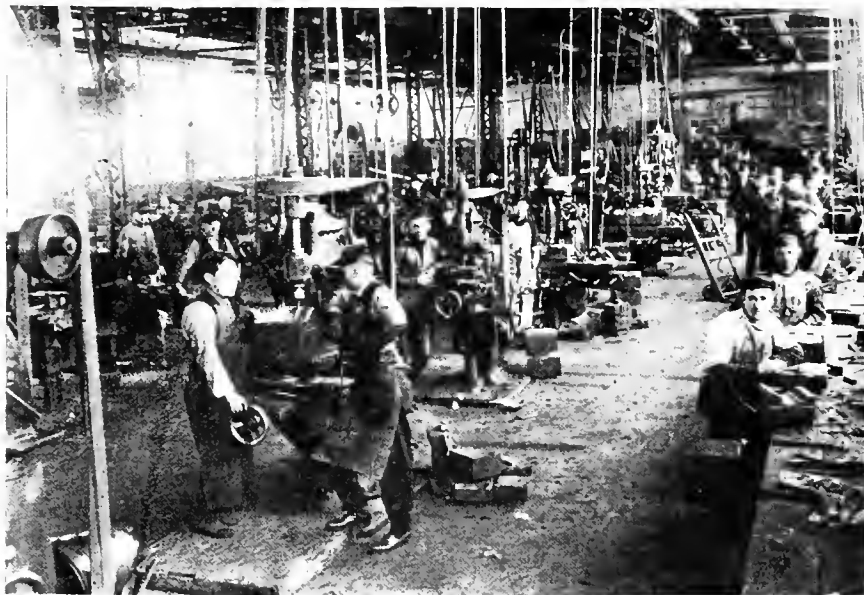

DIE-SINKING DEPARTMENT, SHOWING TYPES OF MACHINES EMPLOYED IN PRODUCING DIES FOR THE HAMMERS.

top of the bins so that forgings can be dropped into the bins by the barrow load. Six Toledo presses are installed in this department, of the type shown in view.

Inspection

Forgings from the cold trim shop are now conveyed to the inspection room, where they rejoin the bulk of the work coming direct from the forge shop. Here the work is gone over carefully, being tumbled in barrels, dressed off in grinders, or otherwise manipulated, according to requirements, before being finally inspected and passed for shipment. Ma-

Die-sinking Department

The section of the main building in which the inspection department is located, also includes the die-sinking department and the office, with minor accommodation, such as tool crib, die storage, electrical department, machine repair, and locker space. The die-sinking department occupies almost half of the section which is 200 ft. long by 66 ft. wide. The equipment installed here is typical of modern practice and includes three Becker and four Pratt & Whitney vertical milling machines; one 12 ft. American, and one 10 ft. Pond planing machines; one Safety Emery Wheel Co. surface grinder; one 24 in. LeBlond lathe, one New Haven lathe, drilling machines, and shapers, the latter including four Gould & Eberhardt and one Hamilton.

Power Equipment

The remaining group of buildings contains the blacksmith shop and power department. The former is equipped principally for the work of hardening dies for the hammers and presses, four large furnaces being installed for this purpose. They are equipped to burn both gas and oil. Large quenching tanks containing brine, oil, etc., are provided for cooling purposes. A 1,500 lb. Massillon open frame steam hammer, and two smith's hearths, are installed for taking care of special work outside of the regular run of the work, while the availability of the furnaces enable special heat treating to be done on occasion.

The power department consists of a boiler room 65 ft. x 60 ft., containing a battery of 5 Goldie & McCulloch 150 horse-power return tubular boilers for supplying steam to the steam hammers, and general heating purposes. Hydro-Electric power is employed for the various motors and shaft drives throughout.

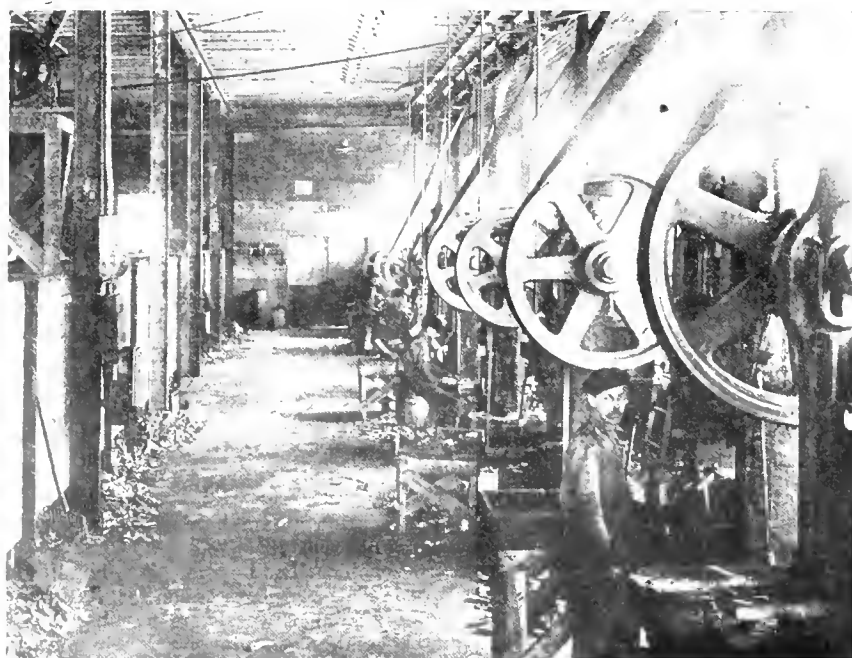

COLD TRIMMING DEPARTMENT, WHERE DROP FORGINGS ARE TRIMMED TO SIZE IN PUNCH PRESSES.

also shop lighting. As shown in the view of the boiler room, gas firing is installed throughout; owing, however, to the heavy demands on this source of heat in winter time, combined with a steady decrease in available supply, the installation of mechanical coal stokers is now under way.

An Ideal feed water heater and purifier is used, while the feed pump installation consists of one Darling Brothers 10 x 6 x 12 in. duplex piston pump, and a Goldie & McCulloch outside centre-packed plunger pump of similar size.

Turbine Driven Blower

An interesting item of equipment is a blowing unit composed of a General Electric centrifugal air compressor running at 3,400 revs. per min., direct driven by a 75 horse-power Curtis turbine. Forced lubrication at a pressure of 4 lbs. per sq. in. is supplied to the bearings, while the air is delivered to the main blast pipe at a pressure of 11 oz. per sq. in. The exhaust steam from the turbine is utilized for heating the boiler feed water.

All the forge furnaces are of uniform design, so that gas and oil can be utilized to best advantage according to the class of work being heated. The furnaces are placed between the hammers and the walls of the buildings. They are not opposite the hammers, however, but toward either side, with one end toward the hammer so that the operator is not exposed to excessive heat. In this respect, mention should be made of the large proportion of wall area devoted to lighting space. Steel sash of the Trussed Concrete Co. type has been liberally employed, which, in conjunction with the numerous ventilators in sides and roof insures working conditions of maximum comfort and efficiency.



FUTURE SUPPLIES OF IRON ORE

MANY interesting facts regarding the world's supply of iron ore were mentioned by Prof. W. G. Fearnside in the second Howard lecture before the Royal

Society of Arts, May 7. Not only in Britain but throughout the world, there is, at this time, a shortage of ore for making fine acid steel, there is, however, abundance of material for making basic steel.

English iron masters wanting ore for the acid steel process invested money in the Bilbao district in Spain in the eighties, and soon after, Germany became a competitor for the product of these fields. The hematite ore was obtained in open quarries on the slopes of the hills, and the Germans, being second in the field, took the dump heaps that were first turned over. That material was of poor quality, but by bringing in mechanical processes of dealing with it, they obtained a wealth of valuable material.

Nevertheless, the ore fields in the neighbourhood of Bilbao were within measurable distance of exhaustion, and if the 19 million tons of ore per annum which were taken from these fields were taken for another decade there would not be much left. Hitherto the ore had averaged something like 50 per cent. of metal. Whilst, however, the Bilbao fields were getting near exhaustion, the ore fields of Spain generally most certainly were not. Along the coast from Bilbao to the west there were large masses of ore which would become available as soon as transport facilities existed. That district could undoubtedly continue to supply a good deal of non-phosphoric material for a good many years.

French Ore Fields

On the borders of France and Germany, around Metz and Verdun, the ores were comparatively near the coal. Briey, Longwy, and Nancy marked the extent of the fields, a distance of 30 miles, and it was there that the great increase of pig iron and steel production, which had been so marked during the present century, had taken place. It had been estimated that, on the German side, there

were more than 2,000 million tons of this ore, and on the other side 3,000 million tons. The first thing that the Germans did on the outbreak of war was to advance their armies at all costs to the western side of this ore belt, and since then they had continued to work the mines. But for that source of material the Germans would have found it very hard indeed to maintain their shell supply. The best of the ore was to be found around Briey, where it varied from 6 ft. to 19 ft. in thickness, and contained about 40 per cent. of iron. Briey only became important in the early years of the present century, and whereas in 1900 it only produced 7 per cent. of the total production of the district, in 1913 it produced 70 per cent. The district as a whole accounted, before the war, for nearly 80 per cent. of German iron, and 90 per cent. of the French, and the importance attached to it by the Germans was emphasized inasmuch as all German peace terms insisted that it should all be on the German side.

Sweden and Norway, in addition to sending about a million tons of ore to this country, also sent large quantities to Germany, to which had to be added the output of Swedish pig iron. Most of the ore was obtained from the district to the north-west of Stockholm, and it differed from anything that we had in this country, or that we imported from Spain or North Africa. Much of the material now being made into Swedish iron was raised from the old time workings, the iron ore being picked out magnetically. Even so, the Swedish Government had recognised for the past ten years that there was a shortage, and had prohibited the export of the best material. More important to British, as well as German, ironmasters was the district between Lulea and Narvik. The mass of ore was five miles long and 80 yards thick. Hitherto we had picked out the less phosphoric material, but the Germans were less particular, and had taken the other, and from it had obtained a production of 5 million tons per annum since the beginning of this century, and they could continue doing so. There were vast resources in the district, and magnificent harbours available, and it seemed exceedingly likely that it would be a valuable source of supply in the future.

American Deposits

Coming to America, Professor Fearnside said that 80 per cent. of the American ore came from the district of Lake Superior. The bulk of the material contained as much as 50 per cent. of iron. The bulk of the best hematite ore came from the Mesabi Range, where there were between 2,000 and 3,500 million tons waiting to be got. Beyond that there were 70,000 million tons of rather lower grade ore that might at some time be worked.

In Canada it was hardly known how much iron ore would become available. The Lake Superior deposits in the United States continued across the boundary, and were equally productive on the other side. There were also plenty of low

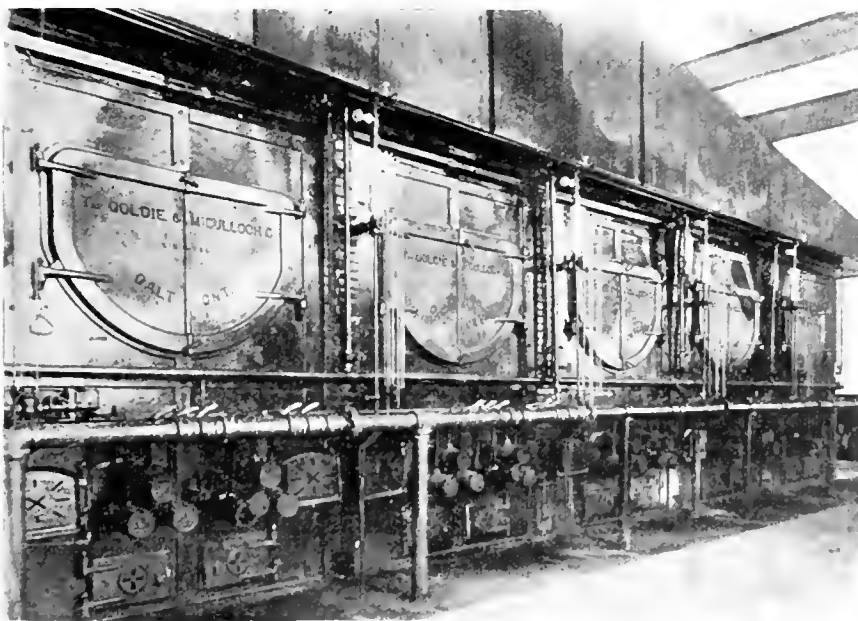

INSTALLATION OF GAS-FIRED BOILERS FOR SUPPLYING STEAM TO THE HAMMERS IN THE FORGE DEPARTMENT.

grade ores available in Canada as well as in Nova Scotia and New Brunswick. Then there were the supplies in Newfoundland, which were worked more under the sea than under land, and produced about 1½ million tons a year, and there was also another great source of supply in Cuba. The latter had been proved to be a quality which was suitable for making pig iron which could be converted direct into alloy steel, as it contained chromium and nickel.

In western France there was a large output which, for want of coal to treat it, had been sent as to two-thirds to Germany and one-third to Great Britain. If Germany could afford to carry that ore to Westphalia, British iron-masters could afford to bring it to England, and larger supplies from that district might be looked for. The ore had been proved to depths as great as 1000 metres.

As to the Colonies, Newfoundland was sending a small quantity to England; there were considerable quantities of ore in Rhodesia, but it was doubtful whether it would pay to bring it to England. There was also plenty in India, as well as in Australia and New Zealand, in each of which countries there was plenty of coal, and in all of them great industries were being set up for the manufacture of steel within their own borders. It was not likely also that South Africa would long be behind.

Reviewing the position, the lecturer said that America, Germany, France and Sweden showed great increase in iron ore output, and all of them were supplying material which required the basic process for its refining. England was comparatively steady, and had not yet adopted that process. The fact was that the supply of hematite ore, and the material suitable for making acid steel, was failing, whilst there was abundance, and no suggestion of a shortage either in Great Britain or elsewhere in the world of the material suitable for the basic process, and it seemed to him that if Britain were to keep pace with the other nations in the race for the world's markets she would have to open out the basic process. It might be said that he who was master of the world's iron was master of the world, and that the question of quality was of more importance than the question of quantity.

CANADA'S 1916 STEEL OUTPUT

THE statistics of production of iron and steel in Canada in 1916 as published by the American Iron and Steel Institute recently show a marked increase over the output of the preceding year. Pig iron production was 1,069,541 gross tons against 825,420 gross tons in 1915. The production of steel ingots and castings last year amounted to 1,286,509 tons against 912,755 tons in 1915. The production of pig iron by grades in 1916 and the four years preceding was as follows, gross tons:

	Basic	Bessemer	Foundry	All Other	Total
1912	49,799	228,742	194,208	129	912,878
1913	58,524	227,662	225,231	3,701	1,015,118
1914	331,456	184,053	174,346	16,117	705,972
1915	660,369	13,714	125,769	25,568	825,420
1916	851,453	12,575	181,748	23,765	1,069,541

The production of steel ingots for last year was 1,255,196 tons and of steel castings 31,313 tons. The production of ingots and castings by processes in the past five years was as follows, gross tons:

	Open-Hearth	Bessemer	Other Kinds	Total
1912	645,062	207,589	400	853,051
1913	768,663	273,391	449	1,042,503
1914	556,910	186,158	284	743,352
1915	884,736	22,521	5,498	912,755
1916	1,245,488	10,968	30,053	1,286,509

The production of finished rolled products in Canada in 1916 was 76,478 tons of iron and 887,332 tons of steel, making a total of 963,810 tons. This compares with the high record of 967,097 tons in 1913. The distribution of finished rolled forms of leading products for the past five years is shown below:

	1912	1913	1914	1915	1916
Rails	423,885	506,709	382,344	209,752	81,497
Structural shapes and wire rods	64,082	68,048	59,050	114,829	174,490
Plates and sheets, nail plate, merchant bars, tie-plate bars, etc.	373,257	392,340	218,125	328,737	707,823
Total, gross tons	861,224	967,097	659,519	653,318	963,810

It will be noticed that rail production last year fell off heavily, due in large part to the extraordinary demand upon steel works for war steel. In the preceding year Canada shipped a considerable quantity of rails into the United States.

The production of iron and steel cut and wire nails in Canada in 1916 amounted to 1,757,000 kegs of 100 lb., as compared with an estimated production in 1915 of 1,636,000 kegs. Cut or wire nails were made last year by nineteen works in five provinces.

The production of finished angle splice bars, tie plates, fish plates and other rail joints and fastenings in Canada by rolling mills and steel works in 1916, all steel, not including spikes, bolts, nuts and similar fastenings, amounted to 6,479 gross tons, as compared with 9,406 tons in 1915, 34,165 tons in 1914, 54,839 tons in 1913 and 52,157 tons in 1912.

The total production of cast-iron gas and water pipe and fittings and cast-iron soil and plumbers' pipe and fittings in Canada in 1916 is estimated at 43,850 net tons of 2,000 lb., as compared with an estimated production in 1915 of 53,700 net tons, a decrease of 9,850 tons.

WATER GAS PRACTICE

By L. E.

THE main problems of carburetted-water gas practice centre around the proper and economical treatment of the oil used for enriching. The tar produced has a lower specific gravity than coal tar, and shows a decided tendency to hold more water in its mass. Occasionally an

even worse trouble manifests itself, viz., that a considerable amount of it persists in remaining on top of the water in the tar well and other places. This is caused by incorrect heats and may manifest itself either when the carburetter and the

perheater are too cold or too hot.

When the heats are too low a large amount of oil is imperfectly cracked, or not cracked at all, and, passing through the seal-pot, thins the tar and makes a composition that will float. On the other hand, if the heats are too high a large amount of lamp black is made, which

will mix with the less amount of tar produced, and the mixed water, tar and lamp black persists in floating.

The oil supplied for use in water gas manufacture is not as a rule quite the same as was delivered in the earlier years of this process of making gas. It very often seems to be a mixture of distillates, for part of which a certain heat is too high, causing stopped pipes and an excess of lamp black, and for the other part the heat is too low, making too much tar, and that of a low specific gravity, and rich in oils somewhat similar to the original oil. Moreover, some American oils reveal a residue that carbonizes on heating and forms deposits on the chequer work in the carburetter, especially troublesome if the air blast enters the vessel rather high up, as a strong flame heats there during the blow, and if much of this carbonaceous deposit collects there it prevents the heats being suitably and regularly maintained.

The oils commonly supplied now often give nearly 50 per cent. more tar than would have been produced under similar conditions some years ago. This indicates the need of higher heat or more heat storage in the chequer work, while a more frequent cleaning of the chequer bricks is also necessary. A little suspected source of tar trouble may be the character of the ash used in the generator, the ash of some coke fuses at the temperature reached during the blow, and is easily removed as clinker. Some of the ash of other cokes does not fuse in this way, and is blown into the carburetter and superheater (in a similar way to the fine dust of ordinary coal gas settings). This ash deposit on the bricks acts as an insulator, and prevents the bricks from being thoroughly heated during the blasting periods. The oil is sprayed onto these insufficiently heated bricks, and the result is the emulsion of tar and water complained of which will not settle in the tar well.

A Foundation for Machine Tool Design and Construction*

By A. L. De Leeuw

The author emphasizes the fact that engineering development has been most rapid in those branches which have had the assistance of mathematics and science. With respect to machine tools, questions are enumerated upon which information is needed in order to follow the line of recent development of the steam engine. These relate particularly to the functions and action of the cutting tool, the action of the cutting lubricant, etc. Experiments already made by the author are outlined and suggested directions of experimentation are indicated.

THE rapidity of progress of the various branches of engineering may be said to be in proportion to the ease with which their principles can be reduced to mathematics. This was perhaps never so clearly shown as in the case of the development of alternating-current apparatus. It may almost be said that the branch of alternating-current engineering was, like Pallas Athene, born full-grown. Here was a case where the science, the mathematics of this branch, was at hand, waiting for somebody to apply it. As a result, alternating-current apparatus has known no period of experimentation, of stumbling, fumbling progress.

Steam Engine Development

Compare this with the slow, hesitating development of the steam engine in its first stages. In that case nothing was known except that steam would exert pressure; but no knowledge existed of the properties of steam, of thermodynamics, nor of the mathematics of engineering materials. The moment that the fundamental facts of thermodynamics were understood, and were reduced to mathematics, the progress of the steam engine became more rapid.

Many instances could be given to show that the opening statement of this paper is true; but the writer believes that the truth of the statement is so well recognized nowadays that further proof may be omitted. There are branches of engineering which are not capable of such rapid development, because their fundamentals are not so much based on science as on art. Though ceramics may be assisted by the engineer, it can never be a true branch of engineering because it depends on art, or skill, and not on science. All that science can do for ceramics is to improve the facilities for applying the art of the workman, for expediting his processes, and for delivering the materials to the artists. The same, though to a lesser degree, may be said of the textile industry.

Development of Machine Shop Methods

There are other branches of engineering which have not had the assistance of science up to the present time, but which might have that assistance if science could dig out the foundations on which these branches of engineering rest. Machine-shop methods have, as a whole, developed so slowly and through so many centuries that we are apt to forget that these methods should, and ac-

tually do, rest on fundamental knowledge of materials to be worked, and tools to work with.

Legendary Knowledge

As it is, the knowledge we have is legendary; transmitted from father to son, or from teacher to pupil, by word of mouth. Now and then some article or book has been written describing the methods in use but without giving any fundamentals, and, as a consequence, is soon forgotten or replaced by some more up-to-date or more fashionable knowledge. Considering the fact that by far the greater part of mechanical-engineering work is done in workshops, and that by far the greater work done in these workshops has to do with the cutting of metals, it is really surprising that no positive knowledge exists on this subject. Millions of people have spent a large portion of their lives cutting metals; improvements in tools and methods have been made, and yet, at the present day, we cannot predict along what lines we may look for further progress. Here and there attempts have been made by individuals to reduce to a system the fragmentary knowledge that we have, but without much success. At the best, it may be said that we now have better records of what we are doing than we formerly had, but any little progress we make is due to the cleverness of individuals and not to the existence of a guiding science.

Establishment of Fundamentals

It might be objected here that numerous investigators have collected data and have made comparative tests of machines and tools for cutting metals. The writer needs to point only to the work of Professor Nicolson and *The Art of Cutting Metals*, by the late Frederick W. Taylor. However, important and meritorious as these attempts are, they do not establish fundamentals, nor were they intended to do so.

We might imagine that the steam engine, without the assistance of mathematics, or the knowledge of its fundamental laws, had stumbled along for a number of centuries, and, by the perseverance and ingenuity of a number of individuals had finally developed into a variety of more or less highly perfected engines, just as machine tools have arrived at that stage. We might then further imagine that some intelligent and inquisitive individual was making comparative tests of these various engines, boilers, etc., and that finally he arrived at a set of data, quite new and of great

interest to future designers and users of steam engines and boilers. Such a man would then have done for steam engines and boilers what Professor Nicolson and F. W. Taylor have done for cutting tools and machines. He would not, however, have established a solid, scientific foundation for the design and analysis of steam engines, such as we have at the present time. Such a foundation can only be furnished by the knowledge of the laws of nature underlying the science, and by the ability to apply mathematics to these laws, which makes the laws of nature into laws of mechanics.

Ideal Steam Engine Standard

To go further with the idea: As soon as the laws of thermodynamics were understood and had been reduced to mathematics, it became possible to imagine an ideal steam engine, which is another term for a 100-per-cent.-efficient steam engine, and to show what is the maximum obtainable efficiency in any steam engine. It was therefore possible to express the efficiency of existing or of contemplated steam engines in percentage of the ideal engine. In other words, the ideal steam engine became the standard or unit of measurement. It was no longer possible for any designer or builder to think that he had produced a steam engine of the highest possible efficiency, merely because his steam engine was twice as efficient as some other existing engine.

Mathematical analysis would soon show him that his engine was still very far from the ideal, that is, from the standard, and after building his engine a test would show him how closely he had approached in practice the product he had intended to build. In other words, he could use his theory to check up his practice. The fact that the inefficiency of the engine was known, left the door open for further improvement.

Boiler Design and Construction

Boiler construction, and especially boiler design and furnace design, made rapid progress when engineers began to apply knowledge of physics, chemistry, and of mathematics to the art. Many times analysis showed that the results obtained were very unsatisfactory as compared with the possible results, and that there was no immediate possibility of making improvements, either because here and there was a gap in the engineer's knowledge, or else the proper materials were lacking for the building of a structure such as his mathematical vision had shown him.

*From a paper presented before the American Society of Mechanical Engineers at Cincinnati, Ohio, May, 1917.

The writer needs to refer only to the history of gas engines and, especially, of steam turbines. Though the engineer was not able to accomplish at once the things he wished to do, the problem was formulated and further developments could be grasped and used for the solution of these problems. Disastrous strains in the rotor of a turbine are no longer disastrous; insurmountable difficulties of lubrication are no longer insurmountable; and the steam turbine is with us, though at one time it was merely the vision of the scientist; or, as he is often called by those lacking in vision, the theorist.

Scientific Development of Machine Tools

What are the things we should know about tools and machine tools to enable us to make these important servants of our present day civilization follow the line of development which the steam engine has enjoyed? Is it possible to develop a theory of the ideal machine tool, such as has been developed for the steam engine?

case would it have been less than 1/2 h.p., assuming a reasonable time element.

If the only function of a machine tool were the removal of metal, we would find that our best machine tool has an efficiency of from 0.12 to 0.22. Even the better of these figures is very low compared with the efficiency of other machines.

If chips could be removed from a piece of work by a straight pull, the ideal machine tool would be one which would remove material with the same amount of power expenditure as that required by the testing machine. While we would not expect to obtain such efficiency in practice, we would certainly aim to reach a much higher efficiency than we are now able to obtain. However, the question is whether material is removed by a straight pull, and this leads to the confession that the writer does not know what the exact nature of the cutting of metal is, and he believes further that he is not alone in his ignorance.

To the writer's knowledge, no experi-

the problem of this wastage of power, tools and machines is of the greatest importance.

Questions to be answered

Among the questions which should be answered before we can design machine tools in a thoroughly scientific manner are the following:

a—When we turn up a narrow disk by means of a square-nosed turning tool of which the width is greater than the width of the disk, is the action of removing the chip purely a matter of tension? Or, if not, what is it?

b—Does the front end of the tool have any function at all?

c—How far from the edge of the tool is the point where the chip strikes the tool?

d—If the action is purely a matter of pull, and the chip does not strike the top of the tool at the cutting point, but some distance farther back, then is it necessary that the cutting edge of the tool be sharp?

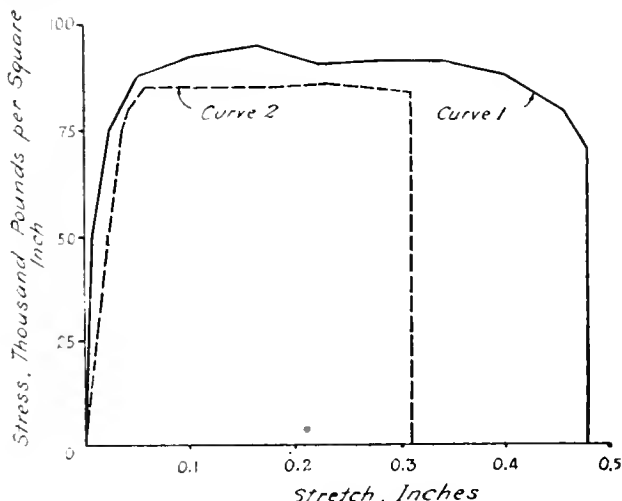
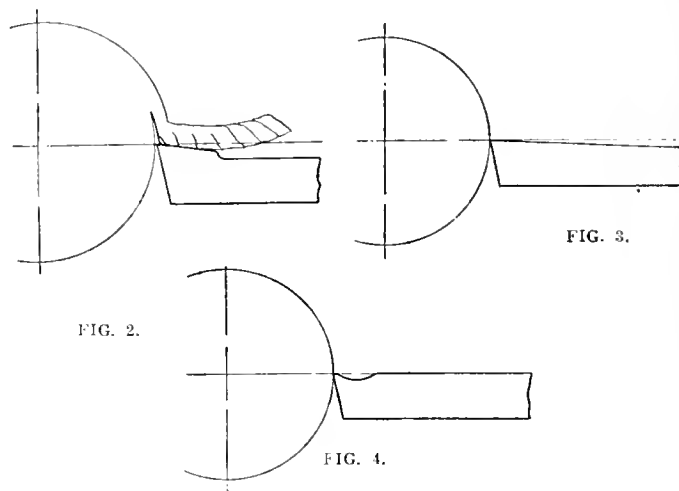

FIG. 1. STRESS DIAGRAMS OF COLD ROLLED STEEL.

Fig. 1 shows two stress diagrams of cold-rolled steel, of which one specimen had a tensile strength of 95,000 lb. and an elongation in 2 in. of 12 per cent., and the other a tensile strength of 85,900 lb. and an elongation in 2 in. of 7.4 per cent. The area of each piece was 1/2 sq. in. and the length between gripping jaws 2 in. The amount of work done in separating the first piece was 3500 ft. lb. per sq. in. of section, and for the second piece 2000 ft. lb. per sq. in. In parting the pieces, the same result was obtained as if half the piece were removed by means of a cutting tool. Of course, this way of removing metal does not permit of controlling the shape or the finish of the remaining piece; but just the same, a certain amount of metal has been removed as effectively as if it had been done with a cutting tool. If this amount of metal had been removed in one minute by a cutting tool used in one of the present-day machine tools, the amount of power required to do this work would have depended on the quality of the tool and the nature of the machine; but in no

ments have been made which establish the true nature of the cutting of metals with a reasonable certainty. In *The Art Cutting Metals* and elsewhere, diagrams are shown of the supposed action of a cutting tool, (See Fig. 2.) The writer is inclined to believe that these diagrams represent a very good first guess; but he wishes to point out that this guess is not based on anything better than the inward vision of the authors of these various works. If this guess is correct, then the act of cutting metal is a removal of the chip by tension, and the amount of power consumed for cutting should not be more than that required by the testing machine. If this is so, the total wastage of power in all the machine shops of the world is enormous; and it certainly would be worth while to investigate this matter thoroughly, merely from the standpoint of the conservation of energy. This is not all, however. Every foot-pound of energy wasted in a machine tool means expenditure of power in destroying tools and wearing out machines. It seems to the writer that



CUTTING WITH LATHE TOOLS.

e—What is the nature of the lamination of the chip?

f—How much power is required for the actual removal of the chip, for the friction between chip and tool, and how much for laminating the chip?

g—What would be the best shape for such a turning tool for this particular turning operation?

h—How does the amount of power vary with the various angles of the tool?

i—If the turning operation is not as simple as the one assumed in question (a) if, for instance, there is a side feed, such as in ordinary shaft-turning operations, how is the cutting action modified by this side feed?

j—If the chip is removed by the action of the top of the tool that is, if the front of the tool has no function, then what determines the nature of the finish of a cut?

k—In what relation does the power required for the side feed stand to the power required for the actual removal of the chip?

A great many other questions which could be asked cannot be answered at the present time, and still more questions would naturally present themselves as soon as we had some little elementary knowledge on this subject.

Action of a Cutting Lubricant

As dark a subject as the action of the tool itself is the action of a cutting lubricant. It is a well-known fact that the use of a lubricant and the nature of the lubricant used affect both the finish and the size. A very pertinent question which might be asked, is this: If the chip is separated by tension, that is, if the point where the chip begins to separate from the work is some distance ahead of the point of the cutting tool, how can the cutting lubricant affect either size or nature of finish?

Another equally puzzling question is: If one of the functions of the cutting lubricant is to reduce the friction between chip and tool, why should we not use a heavy lubricating oil instead of a light lard oil which has practically no lubricating qualities?

Or again, we might ask this question: If, as facts seem to show, the best results are obtained with a cutting lubricant which has little viscosity and which, therefore, can readily rise between chip and work by capillary action, what is the action of the oil on the separation of the chip, seeing the oil only gets to the point of separation after the chip is separated?

Angles of Cutting Tools

Even more puzzling than the effect of a cutting lubricant on finish is the effect it seems to have on the size of the work. We do not see at the present time how it is possible for the lubricant to influence the size, yet that it does do this has been observed a great many times.

The writer had occasion to look into this matter when trying to determine the best cutting lubricant for automatic screw machines on small and medium-sized work. The lubricant in use was a mineral oil with 15 per cent. lard oil. A certain job was selected, for which a form tool was used, and 24 screws were made with the regular compound. The screws came true to size within the limit of one-half of one thousandth. The oil was then removed from the machine and machine and tools were cleaned. The cutting compound to be investigated was substituted, and another 24 screws were made. These screws were all larger than those cut with the regular oil. Furthermore, they varied from two and one-half to five thousandths over size. The machine was once more cleaned, and the original oil put back. The screws again came uniform and to size, showing that the cutting of the first 24 screws had not dulled the tool or caused any other disturbing element to enter into the equation.

The fact that the cutting compound caused the screws to be oversize might possibly be explained by a difference in heating or cooling effect of the different lubricants; but how can the difference in size of screws made with the

same lubricant be explained when there was no such difference with the use of oil?

Many other questions could be asked which cannot be answered at the present time. This should not prevent us from carefully investigating the true action of cutting metals, and determining the

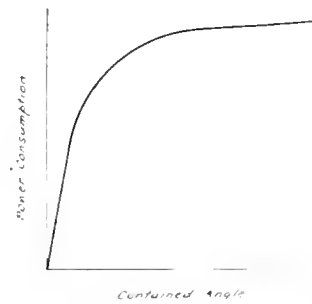

FIG. 5. PROBABLE RELATION BETWEEN CONTAINED ANGLE OF CUTTING TOOL AND POWER.

fundamental data, if we are interested in this matter in a purely scientific way. However, the engineer should not indulge in scientific investigation unless he feels that the results will be of practical value. To be of value, the results should lie in the direction of saving of power, diminished wastage of tools, and less strain on the machine; or in the direction of increased output, with or without the other advantages. That such advantages may be reached seems very clear to the author, and he wishes to outline some isolated experiments which, though not complete in themselves, point to very interesting possibilities.

Forged spindles of sixty-point carbon steel were roughed by a tool as shown in Fig. 3. As a rule, the tool was able to rough three spindles before a breakdown. In its broken-down condition the tool appeared as shown in Fig. 4. A hollow had been ground out by the chip, but a land of a little more than 1-64 in. in width had been left at the front end, showing that the extreme front of the tool had not been in action. The experiment consisted of carefully measuring the broken-down tools and making new tools of just that shape; in other words, a tool like the old tool, but with a hollow ground in the top of the same shape size, and location as in the old tool.

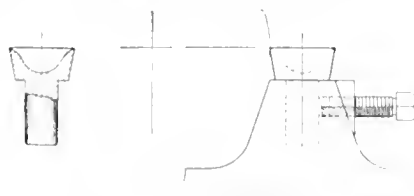

FIG. 6. AUTHOR'S SMALL ANGLE TOOL AND TOOL HOLDER.

This tool is shown in diagram in Fig. 4. The hollow was carefully polished, and a tool thus prepared would rough from 9 to 13 spindles. Examination showed that the hollow in the tool would remain smooth almost to the last, and that a complete breakdown followed very

soon after the surface of the hollow began to show scratches. No tests of power consumption were made, but it may be assumed that the power required with the old tool was more than with the new tool, as the chip did not have to bend so sharply and as the work required for hollowing out the tool was omitted.

Another interesting point about this tool was that the actual contained angle between the front of the tool and the front of the hollow was much less than we would have dared to make between the front and top of an ordinary lathe tool, especially if this lathe tool were to be used for roughing. Nevertheless, under the conditions given, this tool with the small front angle stood up better than the original tool with the large angle.

Effect on Size of Work

In "the Art of Cutting Metals," Mr. Taylor stated that his experiments showed no perceptible difference in power consumption for various contained angles of the cutting tool. The writer thought that this conclusion would probably be correct only for the range of cutting angles tried by Mr. Taylor. He imagined that the relation between contained angle and power consumption would probably be a curve of the nature of Fig. 5, and that all the experiments made by Mr. Taylor were within the horizontal part of the curve.

The writer therefore set out to experiment with angles much below the angles mentioned in "The Art of Cutting Metals." Realizing that an ordinary lathe tool would not stand up with much smaller angles than those used in present-day practice, he devised the tool shown in Fig. 6. This tool is a body of revolution, and was held in a rigid block of metal, and directly over the lathe carriage. Fig. 7 shows the arrangement of tool and tool holder used. The tool was used for turning, preparatory to grinding, milling-machine overarms, about 4 1/2 ins. in diameter and 5 ft. long. When the tool gave out, it was turned in the tool holder so as to present a new piece of the edge to the work. In this manner, from 12 to 16 settings could be made with one sharpening of the tool. The sharpening itself was a matter of circular grinding. The tool would make a very smooth cut, and without a steady rest would turn half the length of the bar with a variation in diameter of less than three thousandths. The surface of the work was unusually smooth, and the amount required for grinding was much less than usual. Unfortunately, the lathe on which this work was done was too large and heavy to make accurate power readings for so slight an amount of power consumed, the cut being only 3/16 in. reduction in diameter and the feed 1/16 in. to 3/32 in. The action of the tool was quite peculiar, and did not give one the impression that metal was being cut. Though nothing was learned about the relative efficiency of this tool, the writer thinks it worth while to bring it forward, on account of the possibilities

for further investigation to which it points.

This matter of the relation of the contained angle to the power consumption for a given cut had previously led to the introduction of the helical cutter, where the actual angle of the tool is not small, but where the tool is presented to the work in such a manner as to have the effect of a small angle.

Another experiment more or less related to the same question was an at-



FIG. 8. EXPERIMENTAL ROTARY LATHE TOOL

tempt to use a rotary lathe tool, such as shown in Fig. 8. The edge of this tool would bear up against the work (Fig. 9), so as to have a very slight difference in speed between the work and the tool, and it was further set in such a way as to make the virtual cutting angle very small. The result was that it became possible to use very high cutting speeds without any apparent effect on the tool. The cutting speed was limited only by the machine. With a reduction of 3/16 in. in diameter and a feed of 12 to the inch, a cutting speed of 650 ft. was used for cast iron as well as for steel. All cutting was done dry. Again no attempt was made to get accurate data as to power consumption, especially as it was realized that the lathe in its present form is not well adapted to this kind of cutting tool. The chips made by this tool were not broken up and were practically solid steel bars. Furthermore, the chips as they came off the lathe were cold enough to be caught in the hand. It is therefore very likely that a test would have shown a remarkably low power consumption.

Though the foregoing experiments are incomplete in themselves, they do show that there are great possibilities before us, and further, that these possibilities lie away from the present-day shop practice. The writer believes that it would be almost useless to try experiments along a great many lines, and by a great many experimenters without a complete plan of campaign; and that such a plan of campaign should be based on some theory or at least on some hypothesis; and he further believes that no such hypothesis can be developed unless we start in collecting some elementary data.

A few years ago, L. P. Alford, Mem. Am. Soc. M.E., who was then in close touch with the writer on this subject, approached Dr. Stratton, of the Bureau of Standards with a view to having that Bureau take up the first investigation of the process of cutting metal. Dr. Stratton promises the assistance of the Bureau, and at a preliminary meeting a general plan of campaign was discussed. The writer believes that an order was placed for a special dynamometer for measuring the stresses in various directions when planing metal. This proceeding will probably give some valuable data, but, according to his ideas,

not of a kind which will make it possible for other experimenters to use them as a basis for their own experiments.

Suggested Lines of Experimentation

The writer believes that interesting results may be obtained by following a line of experimentation such as the following:—An instrument should be built, somewhat along the lines of a microtome, in which a soft material is to be cut by a razor-like blade or tool. This tool should be arranged so that it can present various angles to the work, and tools of various contained angles should be experimented with. The angles presented to the work should vary as to angle of clearance, angle of rake, and angle of shear. A dynamometer, which should be part of the instrument, should register the pull required for the cut. The material to be cut should be standardized, and it is suggested that paraffin may fill all requirements; by selecting a paraffin of standard melting point, we would also get a material of standard hardness. In this manner the relation between cutting angles and power required could be established over a very wide part of the curve. Though the actual figures obtained would not be immediately applicable to metal cutting, it would make it possible to find the controlling law, and, this done, it would

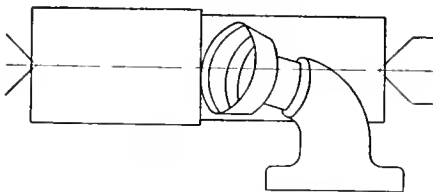

FIG. 9. ROTARY TOOL MACHINING A SHAFT.

then be possible to investigate the cutting of harder materials over a small portion of the curve and compare this portion with the corresponding portion of the curve already obtained. The same instrument could possibly be used for tests on such materials as lead, soft white metal, etc.

Another line of experimentation would be to arrange some machine tool, such as, for instance, a lathe, for running at very low speed, say, 1 in. per hour; mount a steel disc on this lathe, and take a cut at the circumference of this disc. In this manner the cutting action would be of the simplest kind, as the tool to be used could be a square-nosed tool of greater width than the thickness of the disc so that there would be no side cut. A moving picture taken at a high rate of speed could then be reeled off at a low speed, and it would probably be possible in this way to visualize what actually takes place in cutting metal. It would readily show whether cutting is merely the result of tension, or whether shear plays a role, or whether both are responsible. It would probably show whether the chip leaves the work ahead of the tool point, and whether or not the front end of the tool is in contact with the work. It would probably show many

other things besides, and might be made the foundation for a number of lines of experimentation.



G.T.R. STRATFORD SHOPS APPRENTICES MAINTAIN THEIR PAST RECORD

THE Stratford G.T.R. apprentices, who have had about forty-five of their number join for overseas service, the most of them now fighting in France doing their bit for the Empire and Canada, and with nearly a similar number working on shells in making munitions to help the boys at the front win their battles, have with these difficulties been able to maintain their high standard by taking first prize at the apprentices' annual examination over the entire Grand Trunk Railway System. For a number of years the other large shops on the system have tried to wrest this honor from the Stratford boys, but have been unable to do so, and not only do the boys themselves feel proud of their achievement, but all employees and citizens in general are glad to know that the boys have again kept up their reputation.

A meeting was held in the assembly hall of the shops on June 1, when Mr. Kelso, master mechanic, congratulated the boys on their success as a class, and also the three individual boys, M. Reynolds, first year; G. Mellors, second year; H. Brayne, fifth year, for having won the highest individual score in their respective years, over the whole system, and H. Brayne for having tied with a Battle Creek boy for fifth year honors over the System. Mr. Kelso also informed the boys that they will get their well-earned excursion, which they are looking forward to. He also called the attention of the apprentices to the untiring efforts on their behalf of former Master Mechanic R. Patterson, to whom must be given the credit of this year's success, as he Mr. Kelso since taking over Mr. Patterson's duties has had so much to learn himself that he had found it beyond his power to give as much time to the interests of the boys as he wished to. Mr. Kelso also reminded the boys of the fact that the other shops throughout the system were not so fortunate as Stratford in having such excellent school facilities to draw from. Other shops have also greater competition in the way of large factories surrounding them, and though full credit is due the apprentices for their success, so much more discredit would be due them if they lost the lead. He also called attention to the fact that the Grand Trunk Railway System is spending a great deal of money for apprentices' welfare, and all they asked in return was faithful attention to duty. Though this year's averages were good, he hoped next year's in both class and shop would be better.

M. A. Humber, the efficient instructor, shares with the boys the distinct honors which have come to the boys of Stratford shops.

The excursion is to Toronto on June 16.

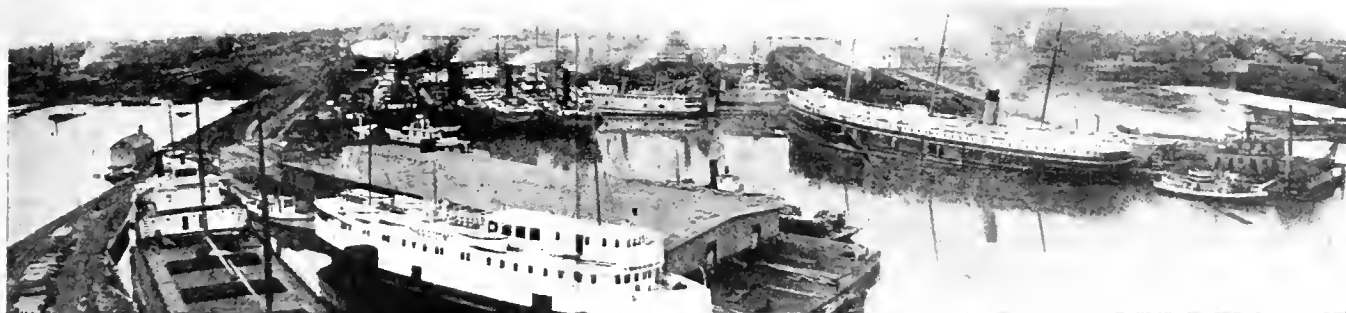

Development of Ocean Service Shipbuilding in Canada--IV.

By C. T. R.

In addition to the widespread requisitioning of vessels for transportation purposes by the Allies, the war attendant and normal merchant ship losses and the many months' almost complete cessation of new construction on the part of the latter, the merchant marine of the world has had the misfortune to become to a large extent the target for enemy submarine activity. All nations have suffered in this respect, hence the almost feverish anxiety being displayed by shipping interests to have the losses made good at the earliest possible moment.

S.S. "WAR DOG" LAUNCHED AT NORTH VANCOUVER

WITH the successful launching of the War Dog from the Wallace Shipyards, North Vancouver, B. C., on May 17, another stage towards the completion of the first steel ocean-going ship yet built in British Columbia, was reached. The vessel is 300 feet long between perpendiculars, 45 feet moulded beam and 27 feet moulded depth, and is of the well-decked type designed to carry 4,700 tons deadweight. Work of this class would not, in older districts, attract much attention; but as only a few years ago fire and cedar trees of the largest size grew where the War Dog was built, special interest attaches to what has been accomplished, not only in a local sense, but in its broader and national aspects. Launches and trial trips have, of course, taken place from the Wallace Shipyards before, but only on this occasion was a general holiday proclaimed. A large number of guests were entertained by the management in their characteristic style and as the vessel started down the ways to the waters of Burrard Inlet, she was christened by Miss Barbara Hogg, of Vancouver.

The War Dog has been built to take Lloyd's highest class and has been, during construction, under the supervision of T. G. Mitchell, Lloyd's representative in Vancouver, while H. Darling has acted as owners' representative. The boat was originally laid down for Japanese interests, but has since been taken over by a Liverpool, England shipping firm. The original contract was placed by Messrs. Dingwall, Cotts &

Co. The main engines have been built by the Wallace Shipyards in their own shops. They are of the three crank triple expansion type, having cylinders 24 in.-38 in.-62 in. diameter, by 42 in. stroke, and at 70 revolutions per minute will be capable of developing 1,300 indicated horse-power. The propeller is built up, having a cast

iron boss and four cast iron blades, its diameter being 15 ft., and its pitch adjustable from 14 ft. 6 in. to 16 ft. 6 in. The main boilers were built by Messrs. J. G. Kincaid & Co., of Greenock, Scotland. They are of the Scotch marine type, 14 ft. 9 in. mean diameter by 11 ft. 0 in. long, and carry 160 pounds working steam pressure. The donkey boiler

is also of the marine type, 6 ft. in diameter by 8 ft. 5 in. long, and was built by the Vulcan Iron Works, New Westminster, B.C. The deck winches have all been supplied by the North Shore Iron Works, Ltd., of North Vancouver. The machinery was all ready to install, in fact, all the auxiliaries that could be put aboard previous to launching were in place and piped up. The work of installing the main engines and boilers is being rushed to completion, three shifts of men being employed. The large sheer legs belonging to the builders and capable of lifting 100 tons will take care of the heavy lifts.

Much credit is due to the staff of the Wallace Shipyards for their accomplishment. Earlier in the war, before the shipping situation was thoroughly understood the firm was engaged in shell production. On completion of their contract, it was evident that more general good would result by getting back to their regular line of work, which they immediately proceeded to do. On the berth vacated by the War Dog, a similar keel will be immediately laid down, work in the drawing office and mold loft for this second ship being now well advanced.

Besides steel construction, the Wallace yards have sev-



BOW VIEW OF "WAR DOG" ON THE WAYS

eral auxiliary power schooners under way. At the time of writing they have had two schooners delivered, one was having the machinery and rigging installed, while three were approaching the launching stage. A large amount of local and deep sea repair work is also carried out at North ancouver, the firm having two marine railways which are more or less constantly employed. Work at No. 1 yard where the steel construction is carried out, is under the charge of R. E. Ellis, H. B. Taylor, the assistant superintendent and chief engineer, has direct charge of the machinery end.

Congratulations Extended

That British Columbia is doing work of great Imperial importance by building ships was the sentiment expressed on the evening of May 13, at the Vancouver Club when Mr. Eadie, on behalf of Dingwall, Cotts & Co., the firm which placed the order for the War Dog, was host at a dinner to celebrate the successful launching of the vessel the previous afternoon. The Wallace Shipyards, the builders, were represented by Alfred Wallace, R. Elwood Ellis, superintendent; H. Bakewell Taylor, engineer-in-chief, and James D. Baker, naval architect. Others present were, Messrs. Henry Darling, W. E. Hodges, J. M. Bowell, W. H. Hogg, James Hopkins, Ed. E. Sykes, A. H. Sperry, Frank R. Harrison, George Kidd, E. W. Hamber, F. W. Peters, E. H. Beazley, Charles S. Meek, Captain C. H. Nicholson, E. J. Leveson, George V. Holt, Robert J. Borland, P. R.

Duncan, H. M. Ellis, J. K. Macrae, W. W. Berkinshaw, B. W. Greer, Knox Walkem, T. W. B. London, and C. F. Boyce.

The evening was devoted to talk of

passage, said Mr. Eadie. In submitting the toast, he also paid high tribute to R. Elwood Ellis and Mr. Taylor for their services.

Various speakers paid compliments to these officials, and a general sentiment was expressed that by building ships British Columbia can be of valuable service to the Empire. In this connection Mr. Eadie submitted a toast to the men of the British merchant service who have kept the commerce of the Empire moving despite the dangers from submarines and mines, in addition to the ordinary perils of the sea. The toast was responded to by Mr. London and Mr. Beazley.

Bankers' views were given by Mr. Hogg and Mr. Holt, while Mr. Knox Walkem spoke on wooden ships. A toast to the popular host was submitted by F. W. Peters. Unfortunately, Captain Crasven, who will command the War Dog, and Chief Engineer Thom, who will have charge below, were unable to be present, but there were many kindly references to them.

ACCIDENT PREVENTION IN SHIPYARDS

THE accident-history of shipbuilding on this continent closely follows that of European countries, where the industry has a high rank among dangerous occupations. A little study of the conditions under which modern shipbuilding is carried on will show why the accident rate is so high, and a little further study will show that many of the accidents are wholly unnecessary.

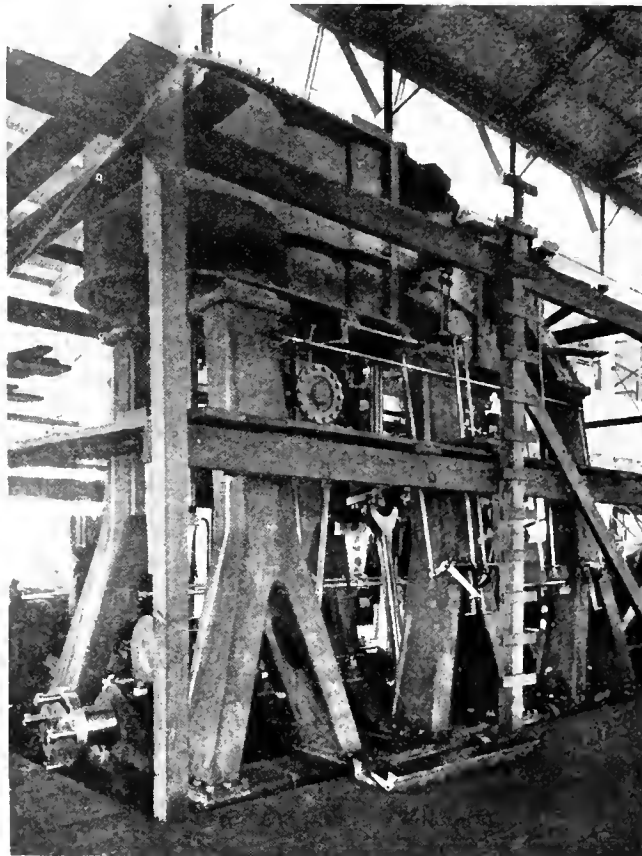

THREE-CYLINDER TRIPLE EXPANSION ENGINES OF THE "WAR DOG" ERECTED IN SHOP.

shipping and Mr. Eade expressed the thanks of the community to Mr. Wallace for his courage and enterprise in establishing such an important industry. The ships are afloat and some are on

under which modern shipbuilding is carried on will show why the accident rate is so high, and a little further study will show that many of the accidents are wholly unnecessary.

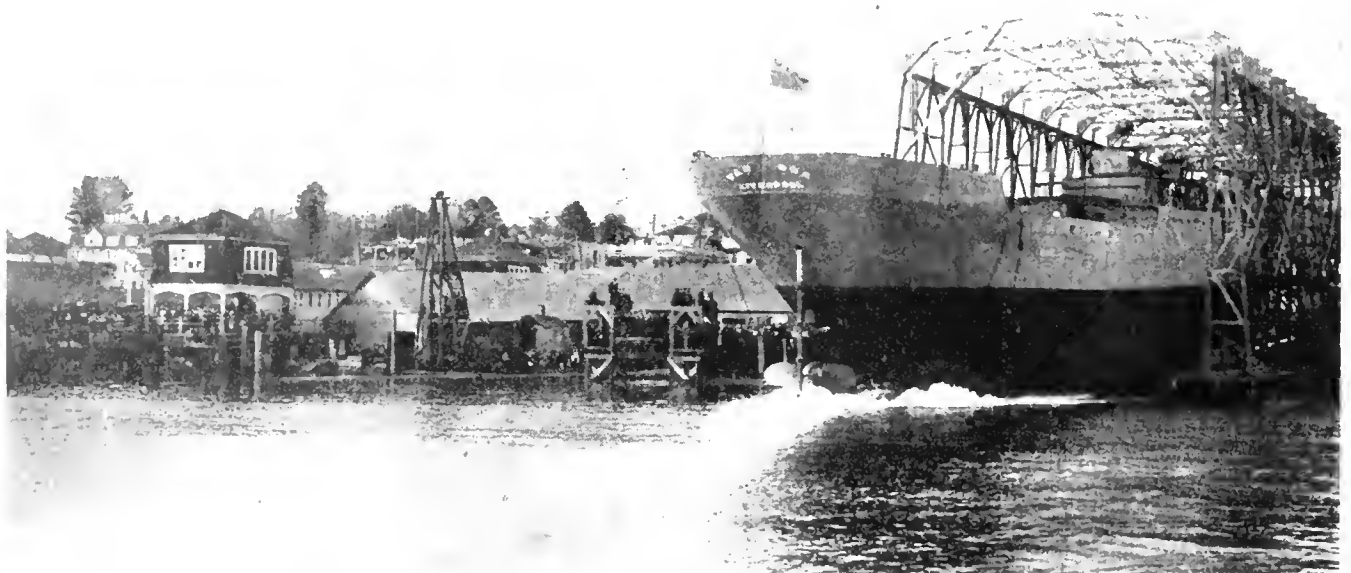

OCEAN SERVICE STEEL FREIGHTER "WAR DOG" TAKING THE WATER AT NORTH VANCOUVER, B.C.

Many of the operations in the modern shipyard, where steel is the chief structural material, are quite different from those that were in vogue in the good old days of the wooden "wind-jamme"; but

some yards special stagings with metal supports are used, but the safety problem is much the same.)

In many shipyards the men who work on the staging are paid by the piece or area system, and they must raise or lower the

to it—nobody else being allowed to move the platform, nor to alter the structure in any other essential way. This plan has worked out very well, largely because these men realize that they will be held responsible for all accidents due to faulty staging.



FIG. 1. A THREE-DECK STAGING. THE BOARDS ARE LAID LOOSELY AND NO GUARD RAILS ARE PROVIDED.

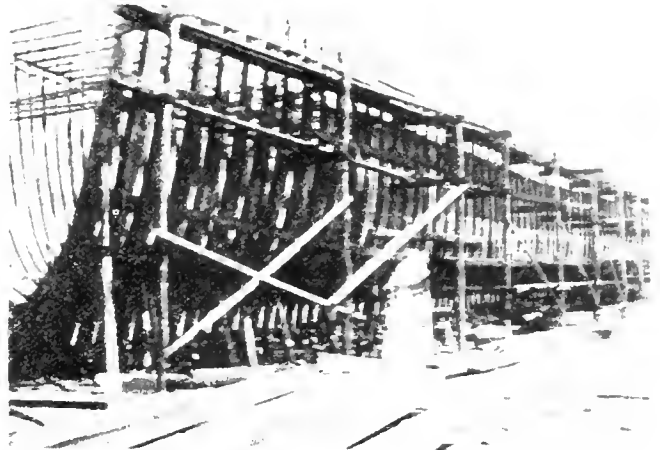

FIG. 2. NEARER VIEW OF A THREE-DECK STAGING.

the changes that have been made have not greatly altered the nature of the hazards to which the men are exposed, and most of the injuries are still due to falls, or to blows from falling objects. The details of shipbuilding vary from yard to yard, according to the magnitude of the operations, the age of the plant, and the experience and personality of the owner or manager. We believe, however, that the practices and suggestions outlined below are fairly applicable to average yards and conditions, says the Travellers' Standard.

Staying Feature

Blocks for supporting the keel are first placed on the ground previously prepared, and supports for a scaffold or staging are then erected around the entire space to be occupied by the ship. From an accident-prevention standpoint the staging is one of the most important things in shipbuilding, because a great deal of plate-erecting, riveting, caulking, and painting must be done from it. In the commonest method of staging-construction, two parallel rows of uprights are set in the ground a few feet apart, each upright being provided, from top to bottom, with a series of holes through which bolts may be passed. The bolts support horizontal wooden stringers or cross-pieces, upon which the plank platform of the staging rests. As the work on the ship progresses, the bolts are usually shifted to higher holes and the platforms raised to new levels, though sometimes the old platform is retained and a new one is laid higher up. (In

staging-platforms themselves. As the shifting of a platform is unremunerative work, it is performed as quickly as possible, and not always with safety in mind. In fact, the accident rate from poor staging became so high, at one time, that a number of shipbuilding companies have placed their staging work in charge of men specially trained

Worn or Damaged Planks and Timbers

One specially marked feature of permitting or compelling the regular workmen to maintain their own staging is the propensity of such men to use timber and planks that are worn out or badly damaged, or defective in some other way, instead of taking the time and trouble to procure sound and suitable material. Planks and timbers that are seriously warped, split, or otherwise badly damaged, should be sawed up or removed from the premises, in order to prevent improper use being made of them. A responsible staging gang, knowing what constitutes a safe working condition and what they have on hand to meet certain requirements, is far less likely to use unsuitable materials.

Men working on a staging often fall from the back of the platform—that is, from the edge that is away from the ship. It is easy to prevent an accident of this kind by erecting a stout railing along the outer row of uprights. A foot-board should also be used, and wire-netting between the two is strongly recommended in addition. The railing has been quite generally omitted, mainly because of the time required to install it and remove it. This objection, which is as old as as scaffolding itself, is not a sound one, because the gain from using the railing is out of all proportion to the trouble and expense involved in putting it up. The man who thinks it is not worth while takes this view because he is sure he will not have an accident; but it is a matter of common knowledge

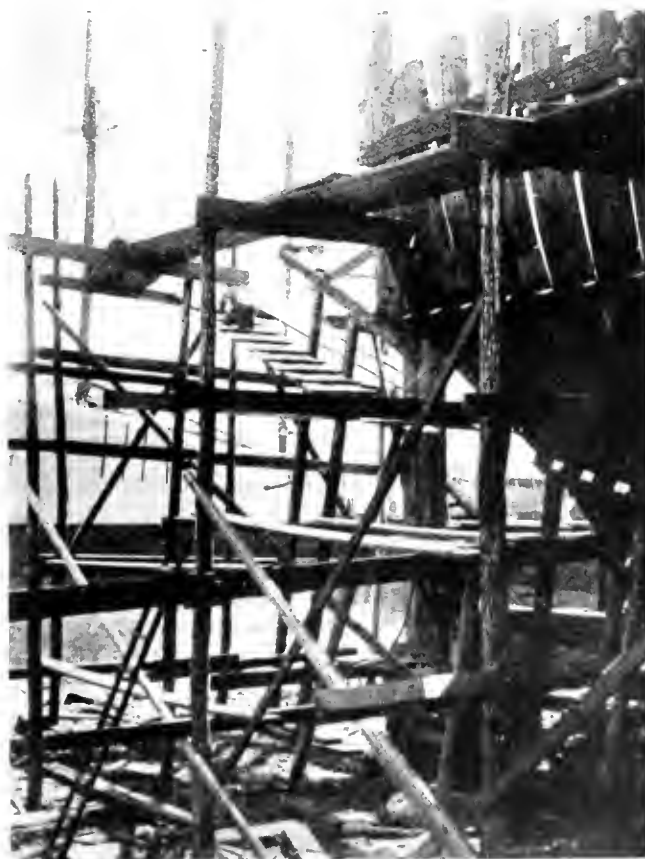

FIG. 3. FOUR DECK STAGING AT STERN OF SHIP. NOTE THE CLEARED RIN'WAY LEADING FROM THE THIRD TO THE FOURTH STAGING

that accidents of this kind occur every little while, and it is much better to be safe than to be sorry. In fact, being sorry doesn't do anybody any good.

In some yards plank shelves are put up in place of guard-rails. This is a good plan, because a strong and properly-located shelf affords protection to the men, and it can also be used for the storage of tools, rivets, bolts, paint-cans, brushes, and small materials of all kinds. The shelf should be guarded by a board on each edge, however, to prevent objects resting upon it from falling off.

The platform planks of ship stagings should be laid with special care. To avoid all chance of tipping, they should never be allowed to project, at their ends more than one foot beyond a firm and solid support; and the men who have charge of the laying of the platform should make sure that there are no "traps," or points at which the planks can tip between supports, so that the men can fall through the platform to the ground.

Staging Attachment to Supports

The platform planks of ship stagings are seldom secured to their supports, except at points where considerable work must be done without disturbing the staging. This is because the men desire to avoid the extra labor involved in shifting the platforms, when the planks are fastened down, and also because it is often necessary to move some of the planks nearest the ship, to facilitate the hoisting of plates and other materials into place. The fastening of the planks is far more important in connection with ship scaffolding than it is in connection with the building of an ordinary brick wall, because the jar of the riveting machines and hammers may cause the planks to shift or "creep" until they come into dangerous positions, even though they were correctly placed at the outset. It is well worth while to

or stringers that support the platform—the cross-bars being made extra wide in this case, to allow for the weakening due to the holes. When a plank is laid down, it is placed so that the hole in one end of it comes directly over a hole in the supporting stringer, and a bolt is slipped through the two, so that the plank cannot shift its position. No cuts are used, and the holes in the platform planks are countersunk, to receive the heads of the bolts. A plank that is secured in this way can be taken up without any trouble.

Much of the interior work, such as the erection and plating of bulkheads, is performed by means of ladders, or from scaffolds swung from deck beams or other overhead supports by means of ropes or chains; and many of the hazards incident to labor on the outside staging are also present in connection with the interior work. Moreover, the interior work must often be done from extremely awkward positions, and where there is a temptation to undertake work a little beyond the safe reaching point. The attempt to reach too far is a common cause of the falling of ladders, and of workmen losing their balance. Ladders from which work is to be done should invariably be lashed, or otherwise securely fastened, both at the top and at the bottom. Even though considerable delay is involved, stagings and ladders should be adjusted to the convenience of the workman, if accidents from over-reaching are to be avoided.

Strict Supervision Required

In view of the vast amount of work that must be done from shipyard stagings, strict supervision should be exercised over the construction and maintenance of all structures of this kind. A busy yard can ill afford to dispense with the services of a capable staging supervisor and his gang of workmen. It is certain, for example, that a competent supervisor would not permit a double-decked staging to be used, without adequate overhead protection to the men on the lower level; yet scaffolds of this kind, without any protection whatever, are very commonly seen in shipyards.

In building a ship there is a certain point at which the accident rate is likely to reach a "peak," and experience shows that this occurs when the frame-

work or ribs of the vessel are being placed. The ship is then a mere skeleton, and the men have to perform arduous work with very insecure footing. During stormy weather they are likely



FIG. 5. RIVETERS WORKING FROM A SUSPENDED STAGING. THE RIVET HEATING FORGE AT THE LEFT IS TOO FAR FROM THE RIVETERS FOR SAFETY OR EFFICIENCY.

to lose their balance from gusts of wind, or beams or plates that are being swung into position are likely to be suddenly swerved by the wind, at great peril to the men. There does not seem to be any way to provide satisfactory safeguards in connection with this part of the work. Only the most skilful and careful men should be employed at it, and they should be set at other tasks whenever the weather conditions add materially to the hazard.

Another hard problem to deal with is the elimination of cuts and bruises and other minor injuries, which are very numerous in the aggregate. Cuts due to handling steel plates with sharp or ragged edges, and finger bruises and lacerations from hammer blows, or from punching or shearing machines, are especially common. It cannot be said that the employment of none but skilled labor constitutes a remedy, for in the main the work that produces these injuries is already in the hands of skilled workmen. The only solution appears to be, to stimulate the men in every way possible, to exercise personal caution.

Hoisting Equipment Risks

Derricks, gantry cranes, and overhead railways are employed to hoist girders, machinery, and other heavy parts, and to transport them to various sections of the ship. During certain stages of shipbuilding, specially skilful handling of the crane and derrick loads is necessary if serious accidents are to be avoided. The men on the skeleton of the ship have a precarious footing at best, so that poor judgment, or a misunderstanding of signals, when lowering or swinging a load, may either cause a workman to be thrown down from his position, or cause him to miss his footing in his quick endeavor to escape. Here, again, is an illustration of the need of providing a competent safety man to actively supervise all operations of a dangerous character.

Unprotected Openings

So far, we have dwelt mainly on accidents due to falls from staging, ladders, and other elevated structures. One other



FIG. 4. STAGING FOR THE INTERIOR OF A VESSEL IN LAYING THE PLANKS. GREAT CARE MUST BE TAKEN TO SUPPORT THE ENDS SO THAT THE PLANKS WILL NOT TIP WHEN STEPPED UPON.

strap or clamp them to their supports, or to make them secure in some other equally effective way. One method that has been tried with considerable success consists in boring holes through the ends of the planks and through the cross-bars

source of falls must also be prominently mentioned. It would be hard to name an industry in which there are more opportunities than shipbuilding affords, for falling into unprotected openings. In the modern vessel with several decks there are many openings for ventilators, bunker hatches, and other permanent uses, in addition to those that are left for temporary building purposes. Unless these various openings are covered over whenever they are not actually in use, workmen and others who may have occasion to go near them are in danger. Stout wooden covers, with the edges on the upper side beveled, are excellent safeguards, and when they must be left off to admit light and air, strong wire-mesh guards may be used instead of solid wooden ones. As workmen are prone to remove covers of this kind, and leave them off, it should be the duty of some one specified man to see that a sufficient number of proper covers are provided, and that they are kept in place.

The influence of poor illumination on the accident rate in shipbuilding has been very marked in the past, but there is evidence that lighting conditions are being rapidly improved. Formerly a ship under construction, having no self-contained lighting plant, usually depended on gasoline torches or oil lamps; and this condition still exists in many sailing vessels and in some steamships. Explosions and fires, with resultant burns, were frequent occurrences. In addition, parts of the ship that were not much frequented were left in total darkness, while other parts were not lighted well

light. It is a simple matter to string wires to any part of the ship and to use the particular size and type of lighting-unit best suited for the space to be illuminated. Particular attention should be given to the lighting of the approaches to the ship, where large-sized lighting-units, suspended well above the ground, are desirable.

Passing Hot Rivets

Each year shows a number of serious and fatal accidents to boys of from fifteen to eighteen years of age. While serving their apprenticeships the boys are at first employed as rivet-heaters, rivet-catchers, and markers, and in performing work of this nature they are often stationed at high elevations and in dangerous and exposed parts of the ship. The boy who heats the rivets throws them to another at some distance, who catches them in a keg or bucket and quickly places them in the holes for the riveter to drive. Speed is essential in order that the rivets may be as hot as possible when they reach the holes. It is evident that the ability of the rivet-heater to throw the rivet accurately has an important bearing on the safety of the rivet-catcher as well as upon that of other employees at work below. If the rivet-heater's aim is poor, the catcher must either reach out at the risk of losing his balance, or else allow the rivet to pass on with the chance of striking someone below. None except mature men should be assigned to this work; and those at work directly beneath the rivet-catcher should be protected by hanging

a substantial, close-meshed wire-netting under the working area, and moving this netting as the work progresses.

Accidents From Falling Objects

Accidents from falling objects are of frequent occurrence in shipbuilding. Planks, bolts, hammers, wrenches, driftpins, and various other tools and materials, are often displaced or accidentally dropped by workmen, and the vibration resulting from the incessant hammering and riveting also contributes to the general downfall, to the constant peril of workmen stationed below. Accidents of this nature can be greatly reduced by

strapping or bolting the platform planks of the staging, as already recommended, and by providing all staging platforms and all shelves and other storage places with effective toe-boards or side-boards. Substantial overhead shields should be erected for the protection of all men

who are stationed where they might be injured by the fall of objects from work-places at a higher level, and like protection should be erected over all passageways or gangways where a similar hazard exists. The spaces between the staging platforms and the hull of the ship should also be bridged over, as far as practicable, with wire-mesh guards supported on pins thrust through holes in the bearer-bars of the staging, or in some other effective way. These can be made in sections, and used over and over.

Approach Gangways and Runways

The main gangways or runways, leading from the ground to the interior of the ship or to the staging platforms, should be well constructed and of ample proportions. They should be properly railed, and provided with suitable landings at the top. When ever there is any likelihood of material falling from them, they should also have toe-boards at both edges. A ramp or runway having a gradual rise, and provided with substantial hand-rails on each side and with cleats to prevent slipping, increases the efficiency and the safety of the men. It seems hardly necessary to point out the importance of promptly removing ice and snow from all runways and platforms, and from all parts of the ship. Further protection should be provided by the liberal application of sand or ashes.

When the staging is dismantled, the various parts of it should be lowered to the ground by means of ropes, instead of being thrown down. If the material is thrown down there is always the chance of some one inadvertently getting in the way of a falling plank, or some one at a supposedly safe distance being hit by pieces that take unusual rebounds. With careful lowering, the timber is also far less likely to be broken or otherwise damaged.

Some shipyards do overhauling and repairing, as well as new work; and although the hazards in yards of this kind are similar, in the main, to those that exist in yards that do construction work only, there may be certain minor differences. A ship is not earning dividends while she is in the repair dock, and for that reason her owners usually insist that she be placed in commission again at the earliest date possible. This means that the repair men must plan in every way to save time, and a limitation of this kind often introduces new dangers.

Paint Work Hazards

For example, painting the interior of the ship with standard, oil-mixed paints necessitates considerable delay for drying, both between coats and after the finish has been applied; and in order to eliminate this delay it is customary to use quick-drying paints, containing highly inflammable substances, such as benzine, benzol, or alcohol. Paints of this nature hasten the work, without doubt; but the use of them is attended by the risk of explosions and fires, and they may also produce injurious effects on the workmen. When paints containing volatile constituents that are inflammable or toxic are used in confined places



FIG. 6. WELL CONSTRUCTED MAIN APPROACH, WHICH IS A PERMANENT STRUCTURE, GIVING DIRECT ACCESS TO THE UPPER DECK OF A SHIP ON THE STOCKS.

enough to permit a maximum of efficiency and safety in the work. Of late years, the extension of lines for the transmission of electrical energy, and the installation of power-houses at the shipyards themselves, have made available a very flexible source of power and

no open lights should be permitted, and smoking or the use of matches for any purpose whatever should never be allowed, on pain of immediate dismissal. The men should also have frequent periods of rest in the open air, and foremen should inspect all confined workplaces at least once every half hour, while the work is going on.

Good ventilation is highly important wherever paints such as we have described are being used, and if the quarters in which the men have to work cannot be ventilated easily and effectively by natural draft or by fans, a plentiful supply of fresh air should be introduced by means of a centrifugal pump and one or more lines of large canvas hose. The air should be delivered, in such cases, at the innermost part of the space, so that the objectionable vapors will be removed as thoroughly as possible. If the work is being done in a pit-like or well-like space, each workman should also wear a belt with a stout life-line running up to the entrance to the workplace, and two men should be stationed above, to draw the workman up to safety in case they become overpowered, or show signs of drowsiness or of unnatural exhilaration. In some cases it will also be advisable to provide the workmen with special respirators, supplied with fresh air by a pump.

First Aid Installation

In view of the large number of minor injuries about a shipbuilding plant, it is highly important to provide a first-aid room, or a hospital. Bruises, slivers, and cuts are not necessarily dangerous if they receive proper attention at once, but the average man will seldom quit work in order to attend to a slight injury, unless he can be treated immediately, so that he can return to his work without much delay. Even though he knows of hundreds of cases of blood poisoning due to the neglect of seemingly insignificant wounds, he will "take a chance" rather than go to his home, or to the office of his family physician, for the treatment of a minor injury; but he can have no logical objection to receiving proper treatment by a competent person at the yard. The facilities at hand should be sufficient to render first-aid in the case of serious injuries also, because proper treatment of this kind has a large influence on the ultimate recovery of a badly-injured man. It is important, however, to see that all first-aid work is done by a fully qualified person. Otherwise a great deal of harm may result.

In the shipbuilding industry there are quite a number of cases of lead poisoning every year. The exposure is usually incurred while sandpapering painted surfaces or removing old lead waste (sometimes in confined spaces such as tanks, or between double bottoms or in bilges), or from breathing the fumes that are produced when red-hot rivets are placed in holes lined with red lead. Exhaust ventilating systems and a sparing use of lead paints tend to reduce this hazard.

Educational safety work is specially

important in the shipbuilding industry which is admittedly a dangerous one. Moreover, the operations that must be performed are of such a nature that it is hard to provide mechanical safeguards that will afford a protection comparable with that which may be had in many other similarly hazardous employments. Hence it is doubly important to study and promote safe methods of doing the work, and to instil the principle of personal caution into every employee about the yard. If the men can be brought to look at the safety question from the right point of view, and good "team work" can be secured, the accident rate will certainly fall off to a remarkable extent.



HELIGOLAND

THE little island of Heligoland rises abruptly out of the North Sea some thirty-four miles northwest of Cuxhaven. The Germans, since the cession of the island to Germany by the United Kingdom in 1892, have spent vast sums of money on it, in the effort to make it an effective naval base. They have built a sea wall of steel, granite, and concrete, twenty-five feet high, all around it; they have constructed a harbor for submarines at great expense; they have honeycombed the rock of its mighty cliffs, two hundred feet high, with galleries; in fact, they have done everything that could be done to transform the island into a "bristling fortress." What they have done, however, is as nothing as compared with what they have been credited with doing, by those who, with a sorry knowledge of the facts, insist on regarding Heligoland as little less than the key to the naval and military strength of Germany. Germany has, of course, done much to the island since the outbreak of the war, but how much is a question which could never, probably, be answered to everybody's satisfaction, because nobody, except the German authorities, knows.

The Heligoland of the days before the war was open enough for anybody to see. Many visitors in the summer months of each year were wont to seek out its shelving beach of white sand, and indulge in sea bathing, in climbing the high red cliffs and in walking about on the green Oberland. And the first thing that struck the new visitor must surely have been the smallness of the place, a little triangular piece of land just a mile long and barely a third of a mile across, only one-fifth of a square mile in all. Centuries ago, Heligoland was at least five times its present size, and a place of no small importance. Like so many islands, it had a peculiar attraction for the people of the surrounding mainlands. They stood in awe of it, and mythology early claimed it for its own. Here the Forseti, the god of justice, had a temple, and had also, according to another tradition, the goddess Hetha, a special object of veneration among the Angles of the mainland. Later on it was the realm of the pagan king, Radbod, and it was hither that St. Willibrod came, in the Seventh Century, preaching Christianity. But all the while the ownership

of Heligoland was in dispute. Sea rover fought sea rover for possession of the island, until at last it became a fief of the dukes of Schleswig-Holstein. Even then, however, it had little rest, for when ever the dukes of Schleswig-Holstein found themselves in need of ready money they had a way of hypothecating Heligoland for loans advanced by the free city of Hamburg. Ceded to England in 1814, the island was, as already noted, transferred to Germany in 1892, and the Heligolanders did not welcome the change. They are not, as one writer clearly points out, Germans in any modern sense; neither have they, by race nor language, any affinity with the Dutch Frieslander. They are, indeed, generally supposed to be survivals of the Saxons who remained behind when Hengist and Horsa and his followers set sail for England. But whoever they are, they are no longer, if one may be forgiven the paradox, for according to all reports, the civil population of the island was removed within forty-eight hours of the outbreak of the war.



LACHINE CANAL TRAFFIC DURING MAY

THE shipping through the Lachine Canal in the month of May, shows marked decreases in almost every feature as compared with the corresponding month of last year. Grain shows a decrease of 1,358,161 bushels, eggs of 2,040 cases — almost fifty per cent., cheese of 5,801 boxes, and coal of 27,330 tons. Butter alone shows an increase. The total tonnage operated was 452,407 as compared with 523,999 last year, and the number of trips through the canal decreased from 968 to 936.

The total for each of the different grains shipped through the canal during the month in bushels is as follows:—

	1916.	1917.
Wheat	1,865,468	1,256,295
Corn	185,340	178,071
Oats	1,298,615	1,026,500
Barley	487,206	197,200
Rye	132,000
Flaxseed	99,598	52,000
Totals	4,068,227	2,710,066

The decrease in produce was equally marked with the exception of butter, which increased from 308 packages to 431. Eggs decreased from 4,186 to 2,146, and cheese from 18,649 to 12,848. Coal also showed a decrease, the total for May, 1917, being 218,512 tons, as compared with 245,842 for May, 1916.

The trips through the canal during the past month were 936, a decrease of 32, as compared with the same month of last year; the tonnage operated was 452,407, a decrease of 71,592 tons, and the cargo tonnage was 377,003, a decrease of 29,165 tons. The passengers through the canal, however, increased from 1,436 to 1,826. The number of light trips through the canal was 401 in 1916 and 383 in 1917.

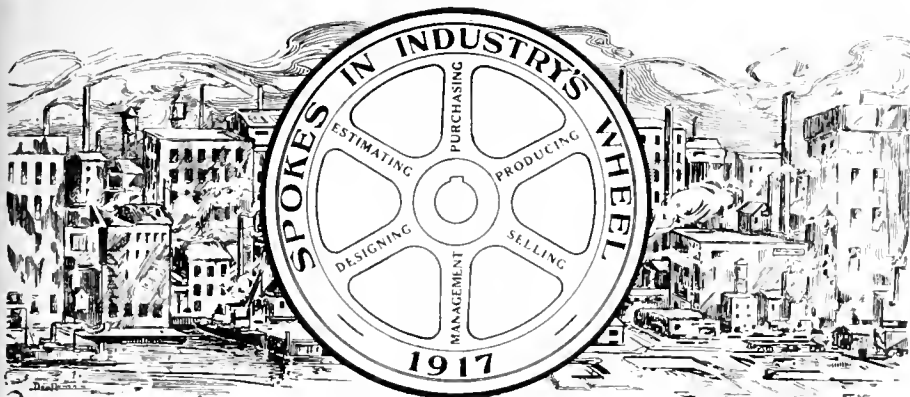

The constitution of industrial enterprise is largely departmental—"spokes in a wheel." This series of articles has for its object the featuring in a racy, interesting and instructive fashion, the training, experience and achievement of those who to-day are transmitting, effectively, energy in their capacity as "spokes in the wheels" of our metal-working establishments.

WALTER LAMBERT

EVENTS of the last few months have emphasized in no uncertain manner the extent to which Britain is dependent on her mercantile marine in the matter of maintaining a full larder in the "Tight Little Island." Present and prospective developments in the art of shipbuilding loom up with impending greatness, and the vital necessity of the present crisis imparts thereby a more than usual interest to the personality of the men behind the ships.

Walter Lambert, A.M.I.N.A. is a representative specimen of that type of Britisher whose availability at the psychological moment has, on frequent occasion in times gone past, served to maintain the supremacy of the British Empire, be the location north, south, east or west. A brief resume of our "Spoke's" career will serve to convince the reader that, no matter where the "Outpost of Empire," when necessity calls, a Son of Albion will be ready, possessed of the requisite scientific and practical training to "carry on."

Of English birth and parentage—he was born in Warwick, England, Jan. 31, 1884—Mr. Lambert would seem to have inherited those characteristics which prompt one to record that in this case a naval architect was born as well as made. Son of a father—an artist—and grandson of the owner of the first screw-propelled steamship on the river Tyne, Walter Lambert may well have felt an inner impulse in adopting his present vocation.

After receiving his boyhood education in government High School, London, he attended the West Ham Technical Institute, taking special engineering subjects, preparatory to the adoption of his present profession. In this connection, it should be remarked that he earned the 1st class certificate for the advanced Stage of Naval Architecture in accordance with the South Kensington regulations.

At the age of fifteen he commenced his apprenticeship in the drafting-room

of the Thames Iron Works, London, well known in the past as builders of battleships and among his experiences during the three years he spent here was that of attending the launch of the British battleship H.M.S. Albion by the present Queen, then Duchess of York. On this occasion the usually enjoyable and con-



WALTER LAMBERT

gratulatory features of the event were utterly destroyed by the tragic drowning of thirty visitors due to a section of the staging being washed down by the backwash from the ship as it entered the water. The remaining two years of his apprenticeship were served with the Londonderry Shipbuilding & Engineering Co., at Londonderry in the North of Ireland, the miscellaneous mercantile types of vessels turned out at this yard proving a valuable complement to the more dignified and stereotyped war vessel work previously engaged in.

But, of making many ships, like making many books, there is no end and,

applying the prophet's dictum to his own work, our "Spoke," on the termination of his apprenticeship, proceeded afield to satisfy his broadening vision and acquire that knowledge which cometh from experience. After two years spent as a junior draftsman with Armstrong Whitworth & Co., Newcastle-on-Tyne on construction of light cruisers and fast scouts for the British and foreign navies, Mr. Lambert joined the staff of John I. Thornycroft & Co., at London and later at Southampton and for eight years was engaged on the design of torpedo boats, destroyers, submarines, motor boats, shallow draft vessels etc., the successful specialisation in which has earned such a world wide reputation for that firm. Mr. Lambert became acting chief of design and foreign construction drafting-room before severing his connection with them to take up the management of the Canadian business of John Reid & Co., Naval Architects & Marine Engineers, Montreal and New York. Mr. Lambert recently completed four years in their service which he terminated in order to commence business on his own account. During his association with Messrs. Reid there was carried out the design and constructional supervision of two lake steamers, two dredges, one train ferry, one self-propelling grain elevator, half a dozen tugs and a similar number of hopper scows all of steel construction; four wooden steamers were also completed.

While nonpartisan in political and municipal affairs, Mr. Lambert has decided views on the present state of world affairs. He is a member of the 5th Royal Highlanders of Canada, and even as this is written, official recognition of the value of his ability is afforded in the announcement of his appointment as Superintendent of Construction to the Director of Steel Shipbuilding, Imperial Munitions Board.

In addition to the professional accomplishments indicated by the foregoing Mr. Lambert holds the position of surveyor to Bureau Veritas and is also Canadian representative of Fleming & Ferguson, Dredge Engineers of Paisley, Scotland. His social activities include membership in Institute of Naval Architects, Great Britain; Canadian Fisheries Association, and Hudson Yacht Club. He is married and resides in Montreal during winter, while summer finds him either at Hudson, P.Q., or Lake of Two Mountains, where his favorite pastime of boat-sailing and water sports generally can be fully gratified.

As would be expected, our "Spoke" has positive opinions on all questions pertaining to Canadian shipbuilding, and has great faith in the future of the industry, provided it receives judicious encouragement from the Government along with proper financial backing from those engaged therein. The future personnel of the industry must also receive wise training as well as encouragement, and, in this matter of training the future generation, Mr. Lambert believes that a decision ought to be made for a boy

before he is fully competent or sufficiently experienced to form his own opinion. "After a boy is 12 years old his education should be suited to his intended line of business, especially if engineering professions are concerned because this age is the most valuable for the acquiring of new knowledge. I believe it would pay shipbuilding firms to take the greatest possible interest in their apprentices, allocating part of their time to purely scholastic and technical instruction. The example of Canadian Vickers is well worth emulating and enlarging upon in this connection,—they hold classes every winter, taking up naval architecture as a science under the direction of their naval architect.

The study of all technical journals bearing upon their business is of greatest importance to mechanics, young and old. Personally, I get through a dozen per month and though at times they pile up because of pressure of work, I regard the close study of modern developments made available by these journals as most essential to successful work."

CANADA'S SHIPBUILDING PROSPERITY

IN the House of Commons, Ottawa, on June 1, the estimates for the Department of Marine and Fisheries were up for discussion, a circumstance which gave the Hon. Wm. Pugsley opportunity to bring forward his favorite theme of encouragement of wood shipbuilding construction in Canada and the Hon. J. B. Hazen, Minister of Marine and Fisheries to outline quite fully in reply what was at present being done both as regards wood and steel construction. The debate lasted for a whole afternoon.

The main point of Mr. Pugsley's contention was that the Government instead of spending money on highways should devote its energies toward aiding the building of smaller wooden vessels in Canada so as to help the coastal and inland water borne traffic which he said was suffering greatly by reason of lack of shipbuilding.

Hon. Mr. Hazen replied that the granting of contracts for 2,500 ton wooden ships only was a matter entirely within the control of the Imperial Munitions Board, which was acting under explicit instructions from the British shipping Controller. The Minister explained that he had brought the matter to the attention of the shipping controller and had suggested that smaller vessels might be ordered. He had received no answer to that communication yet.

In reference to demand for Government ship construction, Mr. Hazen pointed out that in the Maritime Provinces 48 wooden vessels were under construction. It was evident from the activity in the shipbuilding industry and from the fact that ships were sold at a good profit that there was no need for bonusing the construction of wooden ships in Canada at the present time.

"The question of building ships by the Government to be run in connection with Canadian railways is an important one and one to which consideration is being given," said Mr. Hazen, pointing out the necessity for moving carefully in view of the large expenditure that would be necessary and the difficulty of financing such an undertaking at the present time. So long as the profits were sufficient to encourage private enterprise the Government would not be justified in entering into competition.

E. M. MacDonald, Pictou, considered the Minister's statement unsatisfactory. Apparently the Government was content to rest upon what the British authorities were doing, instead of encouraging the building of ships for the Canadian coastal trade. The ships being built for Britain, he pointed out, would not supply the need for Canadian coastal vessels.

Hon. Mr. Pugsley insisted that the building of wooden ships was of primary importance to Canada and declared it was a mistake in view of this for the Government to propose spending \$10,000,000 on highways. He read a letter from W. L. Gear, director of steel shipbuilding, stating that the Munitions Board had been authorized to build a certain number of wooden ships of approximately 2,500 tons each, 250 feet long and 40 feet beam. With regard to construction in eastern Canada, the essential point would be to satisfy the Board that suitable lumber could be secured, as they could not rely on getting this lumber from British Columbia, owing to freights and its use in shipbuilding there.

In view of this, Hon. Mr. Pugsley argued that as the Government controlled a Transcontinental railway they should utilize it for bringing suitable lumber from Prince Rupert to points in the east where ships of 500 tons and upward could be built.

Hon. Charles Marcell said there was a time when the mother province of Quebec shared with the glories of the Maritime Provinces in shipbuilding. All that had been said regarding conditions in the Maritime Provinces applied ten times more forcible to the St. Lawrence with its immense traffic and the greatest port of Canada. He painted a gloomy picture of shipbuilding in Canada, declaring that there was an increasing shortage of tonnage everywhere, both on the ocean routes and on the inland waters. He, therefore, strongly argued that no time be lost by the Government in aiding shipbuilding so as to assist the carrying trade of the St. Lawrence and the Great Lakes.

Hon. Mr. Hazen replied that he hoped Mr. Marcell was generally better informed than he was on the question of shipbuilding. He produced figures showing that six large steamers were being built at the Vickers' Works, at Montreal, of seven thousand tons each, another vessel of 2,300 tons and several other vessels of lesser tonnage, while today 2,000 men were busily employed there. He also showed that a large amount of ship-

building was being done by the Davies' plant at Levis, by private companies at Sorel, and that a company on the Isle of Orleans was building four wooden ships running from 1,500 to 2,000 tons each. The Minister said he had been informed by Mr. Norcross that a large quantity of British Columbia timber was being used in these vessels, a total of nearly a dozen being built at various points on the St. Lawrence.

Hon. Mr. Hazen then instanced a number of points in the Maritime Provinces where vessels were being built, while at Port Arthur five of 3,400 tons were being built, several large vessels at Collingwood, eight large steamers at the Polson Iron Works at Toronto, and a number of others at various points on the Great Lakes and other parts of Canada. The net result, he said, was to show that far from Hon. Mr. Marcell's contention being correct there was a very great activity in shipbuilding in Canada.

As to wooden vessels, Hon. Mr. Hazen said the British Government had issued an order excluding sailing vessels from the war zone, owing to their inability to escape from submarines, but this might not apply to vessels using auxiliary power.

U. S. S. CORPORATION TO BUILD CANAL BARGES

FOR the present the United States Steel Corporation is considering building nothing but steel boats, 12 feet depth, that will go through the barge canal. It was for a site for a plant for such construction that the corporation purchased through Joseph P. Day from the Newark Factory Sites, Inc., the half mile frontage on the Hackensack River adjoining the Newark branch of the Jersey Central Railroad. The tract embraces about sixty-two acres, running back 1,400 feet to Hackensack avenue. Adjoining this property is another tract of eighty-eight acres, which E. H. Gary is considering purchasing, and if later on the Steel Corporation decides to go into the business of building larger vessels this property will be taken over and improved. It is understood that Chairman Gary, James A. Farrell, president of the Steel Corporation, and August Ziesing, president of the American Bridge Co., picked out the Hackensack River site after having made an exhaustive study as to railroad facilities, labor market, and depth of channel of all the tidewater property around New York. An important factor was the width of the river at the point chosen. The property is right in the centre of the Newark meadows and was partly filled when the Hackensack river was deepened recently.

The tract is midway between Jersey City and Newark and fronts about 1,200 feet on the Lincoln Highway. On one side is land recently taken by the Government for a wooden ship plant, and almost adjoining is the site of the Ford Motor Company's new \$10,000,000 plant. The labor required to operate these new industries will roll up into the tens of thousands.

PRODUCTION METHODS AND DEVICES

A Department for the Interchange and Distribution of Shop and Office Data and Ideas Evolved from Actual Practical Application and Experience

SPECIAL WAVE AND GROOVE MACHINE

By J. H. R.

ONE of the details in connection with the manufacture of shells has called for considerable ingenuity on the part of plant executives, and that has resulted in the design and construction of numerous devices for its accomplishment, has been the operation of waving the ribs and undercutting the sides of the groove into which the copper rifling band is pressed. Owing to the firing duties that are imposed upon this important portion of the shell, strict adherence to dimensions and specifications are essential for the accurate fulfillment of the desired conditions. The two principal characteristics of the copper band groove are the staggered position of the ribs and the dove-tailed sides of the groove; the former to prevent the band turning and the latter to retain it in position when the shell is being discharged from the gun. The failure of either of the conditions will destroy the predetermined flight of the projectile, and may often result in destruction where not intended.

With a certain objective in view it may seem surprising that the actual accomplishment of the machining operation should be obtained in such a variety of ways, but when it is realized that many of these attachments were designed and constructed without outside aid, being based on previous individual experience and available plant resources, it is not remarkable to see so many different details in the operating mechanism of these fixtures. The cut herewith illustrates a special machine designed and constructed by the Ingersoll-Rand Co. of Sherbrooke, for machining the copper band groove on 8 inch

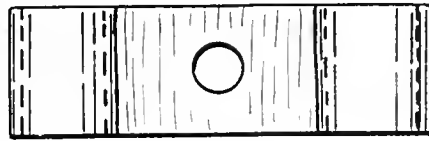

FIG. 1.

shell. With the groove roughed out at a previous operation, the shell is held firmly on a special expanding arbor, the nose end being supported by the tail center. The lathe is provided with two saddles; the forward one, which carries the front and rear tool slides being permanently set in the desired position, the inward motion of the cutting tools being obtained by the cam bars secured to the traverse saddle. The undercutting tools are supported in slides at the rear of the fixed saddle; these slides being set at the desired angle for undercutting, and located at an sufficient distance apart to prevent the slide from interfering when operating.

The special feature of this machine is however, the arrangement provided to oscillate the waving tool slide in a parallel direction to that of the lathe spindle or shell axis. This movement is obtained by means of a triple thread of $\frac{1}{4}$ inch pitch, giving a lead in one revolution of $\frac{3}{4}$ inch. Fitted to the head end of this screw is a short lever which is connected to a crank by means of a short link, the crank being attached to the end of a shaft which is revolved by

means of suitable gearing to give the desired number of oscillations per shell revolution. The operation of this link motion causes the waving slide screw to oscillate through an angle of 60 degrees, which with a screw of $\frac{3}{4}$ inch lead, gives a side movement of $\frac{1}{8}$ inch. The development of the wave is slightly different than that obtained by the face-plate cam method, but the variation is so slight that the holding power of the wave is not effected.

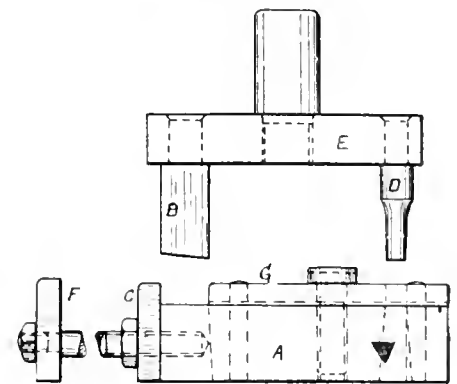
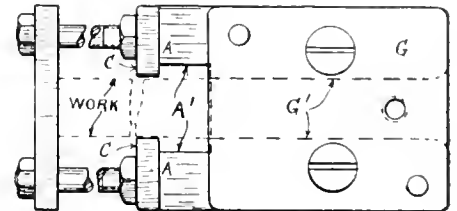

FIG. 2.

PRESS TOOLS FOR METAL CLIPS

By W. G.

THE accompanying drawings show a set of press tools which were gotten out for producing a limited number of the sheet metal clip shown in Fig. 1. Simplicity was aimed at throughout, consistent with satisfactory results.

Piercing and cutting off the blank strip is performed by the punch and die shown in plan and elevation in Fig. 2. Die A is a rectangular block of tool steel in one end of which a slot A' is formed to act as a guide for cutting-off punch B. Guide plates C for the back of this punch are necessary to prevent it springing away from the edge of the die, and pulling piercing punch D out of alignment. Both punches are riveted in place in punch plate E, which is threaded to the shank as shown.

A stop plate F is carried by a couple of studs which also hold guide plates G in position. Stripping plate G is of mild steel with a groove G' on its underside for guiding the blank strip, the groove being amply deep to allow for unevenness in the strip.

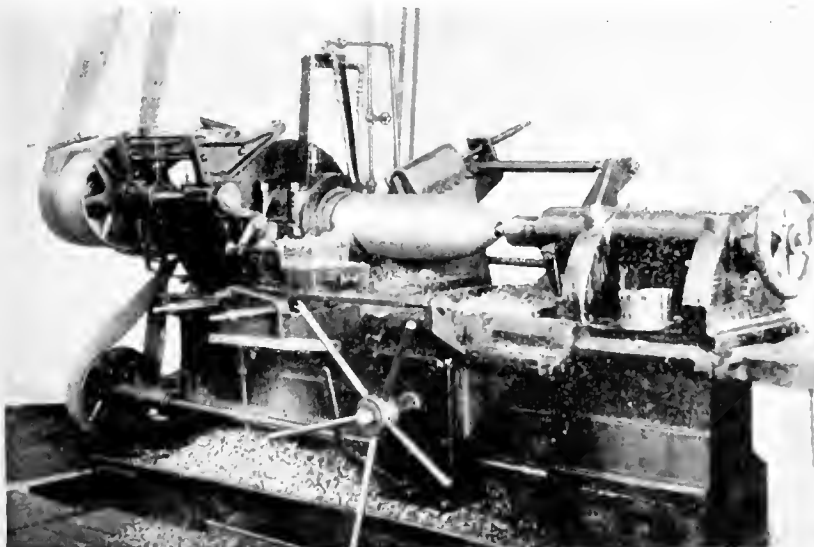

SPECIAL WAVE AND GROOVE MACHINE.

Bending

Elevation and plan of bending operation are shown in Fig. 3, the die J being of case-hardened mild steel with a groove J' on its upper face for locating

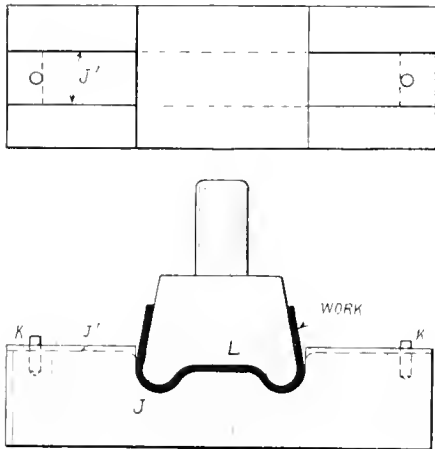

FIG. 3.

the flat strip which is centered by pins K. Punch L is also case-hardened, and has its end faces cut back past the vertical in order to produce a slight "set" on the work which assists the final or curling operation.

Curling

In Fig 4 are shown the curling dies. Lower die M has guide plates N on each side for holding plugs O in position. These plugs are inserted after the work is laid in position and are with-

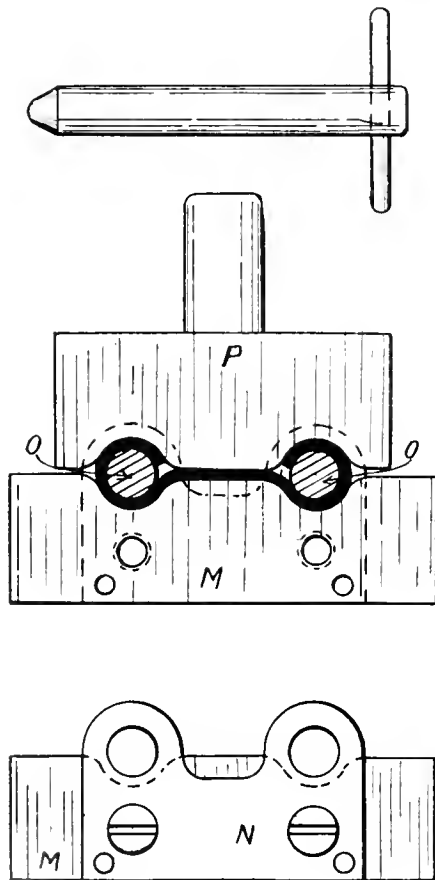

FIG. 4.

drawn to permit removal of the finished article. The ends of upper die P are extended to insure ample backing for the parts which come in contact with the work first; it is also made somewhat wider than the work so that the space between plates N will permit easy removal of the work.

BORING AND REAMING LINE HOLES

By J. Wright.

IN boring line holes in lathe heads, frames, engine beds, etc., the ordinary type of broached bar is used, and for the reaming operation either shank or shell-reamers are employed. The bar is placed on centres in a boring mill through the cored holes in the work, which is strapped to a carriage. The common type of cutters used are the single end square cutter, Fig. 1, fitting the broach in the bar, and the double end flat cutter, Fig. 2, both being held in position by a driver taper key. Two sets of cutters are required for the roughing and finishing cut.

The objection to the single end cutter is that it springs the bar out of truth, cutting as it does only on one side, it being left to the finishing cut and reamer to bring the holes again into alignment. Where two or more holes, supposed to be in line, are bored, it is impossible to make them line with this type of cutter, hence the introduction of the double-ended cutter to overcome this difficulty. These cutters, with few exceptions, work to better advantage. There is no clearance on the faces as on a single end cutter, and for this reason they have to be ground oftener and are soon worn out. They also require a fine feed as the cutting edges break easily, which makes them expensive wherever used. Driving the taper key in and out is another bad feature, as it springs the bar and upsets the centres.

little grinding and will not break. This latter fact is not to be overlooked for the reason that it will stand a much coarser feed in the roughing cut without breaking than can be taken with any other cutter. The cutters are made from drill-rod and since they are so cheap several should be kept on hand.

When they become worn down with a few grindings they should be thrown away and replaced with new ones. For holes less than two inches in diameter the cutters should be 5/16 inch in diameter. The lengths are turned the desired diameters and then backed off as A. Fig. 4; the angles, BC, Fig. 4, are then milled for proper clearance. Two sets should be used for roughing and finishing. A 1/4-inch headless screw is sufficient for holding the cutters in position. The spotting D, Fig. 4, in the cutter for the point of the screw should have a liberal depth. The cutter should not be driven in the bar, but should be made free enough to move in and out by hand.

A slight improvement in the reaming operation has also been made. After the holes have been roughed out and the finishing cut taken they are ready to be reamed. This is usually done by placing a shell reamer on a shank and feeding it through the work by hand. The reamers are held to the shank by pins about 1/8 inch diameter that fit into the groove E. Fig. 5, on the end of the reamer. The pins are driven into the shank to prevent them from falling out. In order to get the reamers on the shank where different size holes are to be reamed, the pins must be removed. Constant driving with a drift and hammer renders the shank out of true, so that an accurate boring operation is sometimes spoilt by the reaming. To overcome this fault, a pin H, Fig. 6, is made so that it can be moved in and out by hand. Wire twice the diameter of that required in the first construction is used. The ends are milled

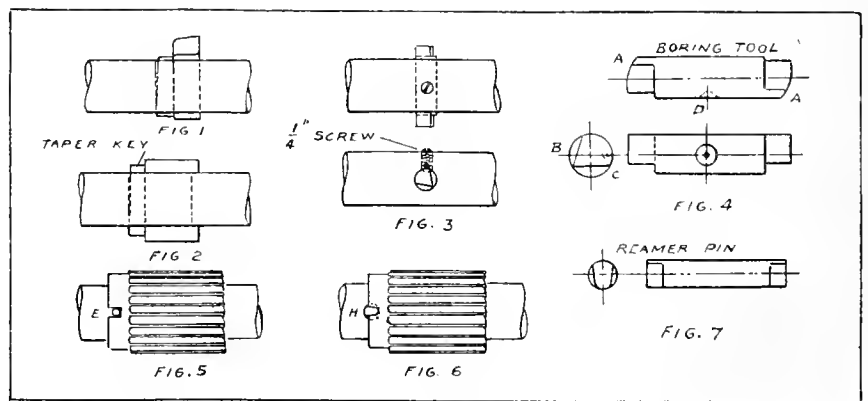

DETAILS OF BORING AND REAMING TOOLS.

Fig. 4 shows a new type of cutter, which as yet is little known. The small cost in making it is sufficient reason for its use, including the bar, Fig. 3, which requires only a round hole, also a tapped hole for headless screw to hold the cutter in position. The bar now used must be drilled and broached to fit both cutter and key. This type of cutter can be used on any class of boring in any metal, steel, cast iron, etc. It requires

5 degrees tapering and the groove in the reamer also, Figs. 6 and 7, so that the reamer when tapped lightly with a piece of babbitt against the pin will fit snugly in the tapered slot, holding both securely on the shank.

This method of manipulating the reamer, together with the improved boring tool is a step in advance over all other methods now employed in boring and reaming holes.

The "Howden" Sectional Type, Water-Tube Steam Boiler

By C. T. D.

With the development of an intensive shipbuilding and marine engineering activity, there has resulted both a tendency and necessity to deviate from the beaten path in the matter of design and constructional detail of a number of the prime essentials entering into one or other, or both of the twin industries. The accompanying article features a type of water-tube boiler now being made in Canada, suitable for either land or marine installation, but which has hitherto figured but little, if any, as a factor in her steam engineering practice.

THE "Howden" boiler as we find it to-day is a development of one designed in January 1861 by the late James Howden, of "forced draught" fame, and who in his lifetime was chairman of both James Howden & Co., marine machinery builders, and of the Howden Boiler Co., Govan, Scotland. As the date when the first Howden boiler was constructed occurred at a stage of marine engineering during which the

thereafter, it will doubtless be interesting after an interval of some 56 years to chronicle the circumstances which initiated and led up to the present design.

In 1861, the usual steam pressures for marine boilers were from 20 to 25 pounds per sq. inch, beyond which it was not considered safe to operate with a salt water feed supply. Shortly before this period, however, several attempts

of the use of high pressure steam through compound engines and the use of fresh feed water, was the chairman of the Howden Boiler Co., who in 1859 contracted with the "Anchor Line" Steamship Co., to equip one of their Mediterranean fruit steamers with his then recently patented compound surface condensing engines and boilers to work with steam at 100 pounds per sq. inch. This steamer built by Alexr.

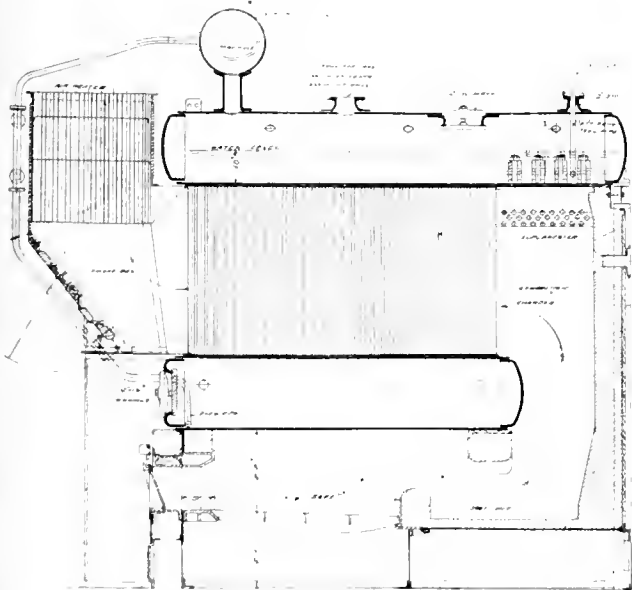

LONGITUDINAL SECTION

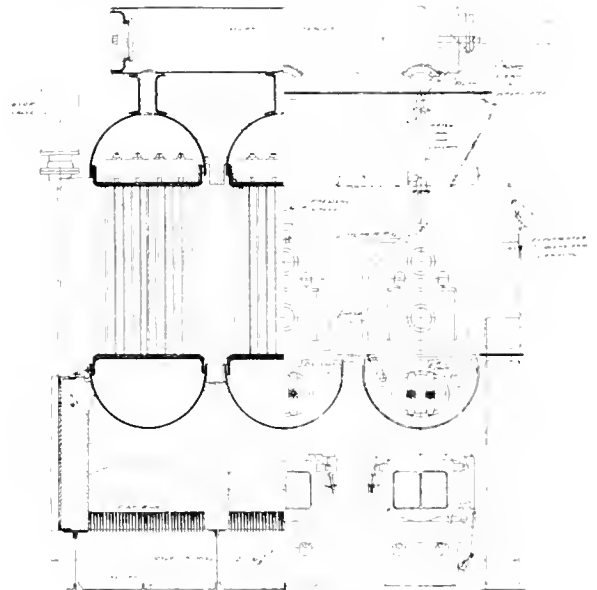

SECTIONAL ELEVATION

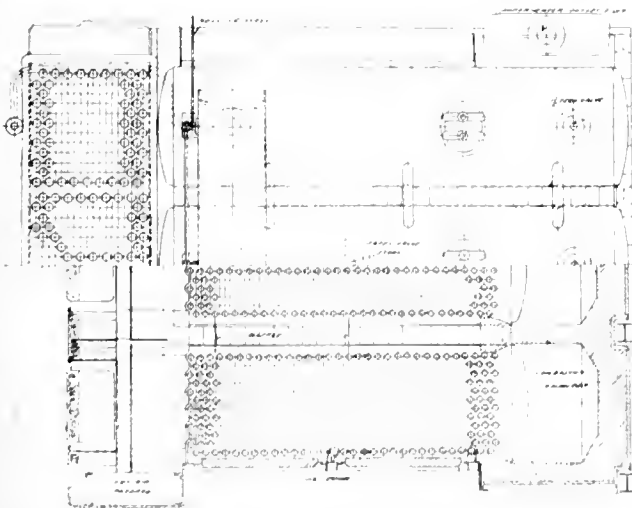

PLAN VIEW

THREE ELEMENT "HOWDEN" MARINE TYPE WATER TUBE BOILER NOW BEING MADE IN CANADA

Stephen & Sons, on the upper reaches of the Clyde, began to run in 1860, being successful and economical, running voyage after voyage without requiring overhaul or repair. Her boiler was as far as known, the first high pressure steam generator to operate successfully at sea in ordinary traffic continuously for a considerable period.

Another screw steamer ordered about

use of high pressure steam for marine purposes took a sudden leap upwards, anticipating a progress which was not generally reached until fully 20 years

had been made to introduce steam pressures of 100 pounds per sq. inch into steamships with compound surface condensing engines. Among these pioneers

the same time by J. H. P. Hutchison for their trade between Glasgow and Bordeaux, and built by James R. Napier, F. R. S., at Govan, had compound sur-

repair. Inaccessibility for cleaning and repair were drawbacks to the boilers and, with a view to giving greater convenience in these respects, a new de-

where the several parts can be carried by men or animals and put together without skilled labor under the direction of one competent engineer. All Howden boilers are designed to be equally suitable for land or marine services. As will be noted from the illustrations, covering boilers now being built by the Polson Iron Works, Toronto, who are the licensees for Canada, the individual units are simple in character, there being the minimum of detail parts,

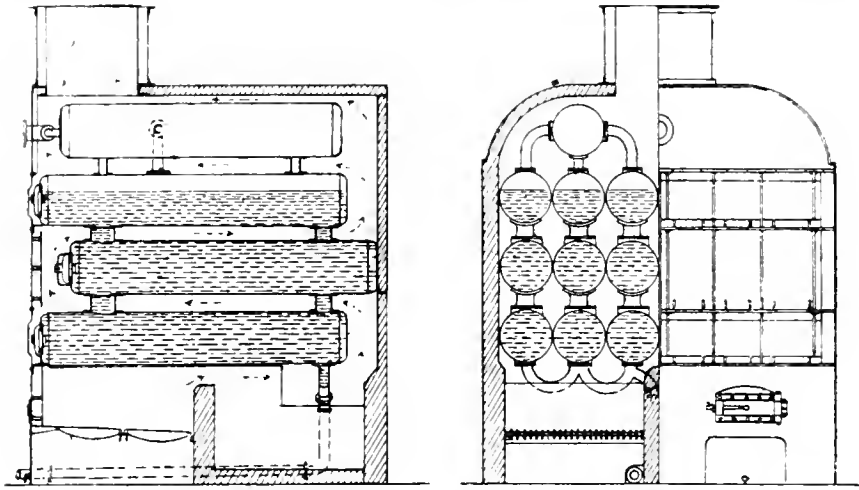

ORIGINAL DESIGN OF "HOWDEN" BOILER, JANUARY, 1861

face condensing engines, also boilers using 100 pounds per sq. inch steam pressure, installed. Owing to the then design of the boiler, however, and the effect of salt water from a leaky sur-

face condensing engines, also boilers using 100 pounds per sq. inch steam pressure, installed. Owing to the then design of the boiler, however, and the effect of salt water from a leaky sur-

sign was developed and gave satisfactory operating results, notwithstanding the fact that leaky surface condensers were responsible for abnormal incrustation of salt on the interior boiler surfaces. The accessibility procured limited materially the heating surface, hence rapid combustion, which progress in steamship engineering necessarily entailed, was more or less negated. The subsequent evolution of the cylindrical multitubular boiler (Scotch), with its simpler style, and greater heating surface in same space occupied, evidenced a more economical design, and being, in addition, better fitted for the marine service of that period, naturally took pride of place, and still maintains a strangle hold.

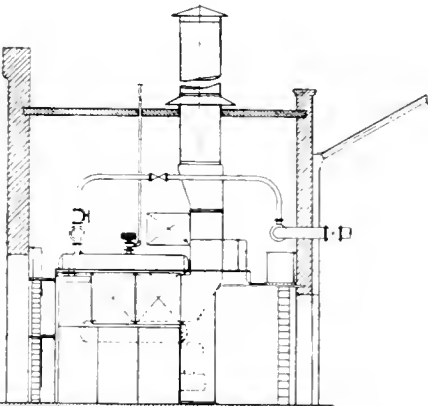

SIDE ELEVATION OF "HOWDEN" BOILER INSTALLATION AT BOROUGH OF BERMONDSEY ELECTRIC LIGHT STATION

face condenser, this vessel never accomplished a voyage to Bordeaux and back without being laid up on account of the boiler requiring overhaul and

The present Howden boiler combines an evaporation from plate surfaces, as in ordinary boilers, with the addition of that from water tubes. It is now constructed under at least three patents—1908, 1910 and 1912, respectively, the last mentioned including a design specially adapted for high speed steam vessels, where lightness and small space occupied are of vital importance, or, for use on land in places difficult of access

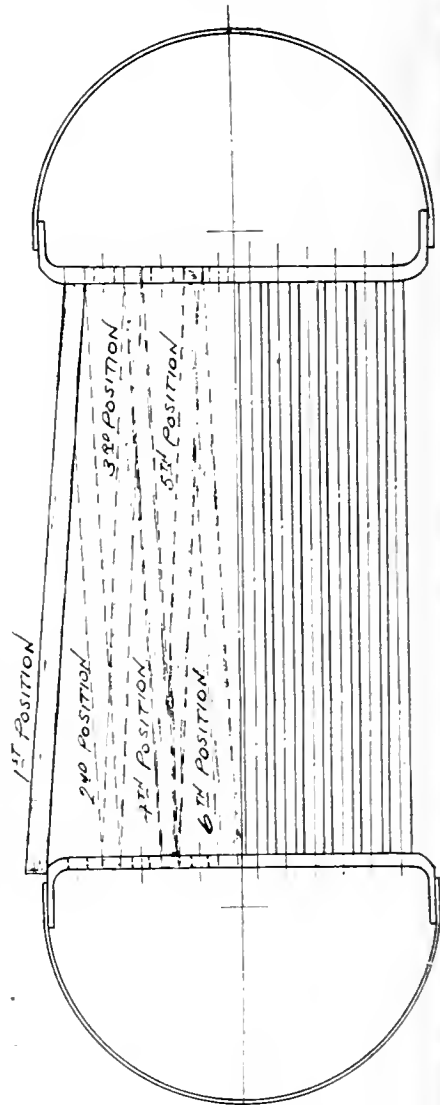

METHOD OF STEPPING-IN NEW TUBES

The worst possible position for a leaky tube is indicated. The intervening tubes are of course cut out and the new one threaded into position as shown. In consequence the holes are slightly larger in diameter than they were originally after expanding. This slackness allows the tubes to be stepped into the various positions. The inner tubes require renewing at rare intervals.

while the sections or elements are duplicates of each other. One boiler may consist of one, two, three, four, or more elements, all the details of which lend themselves to repetition and duplicate work, therefore all parts can be made by special machinery to standard gauges, ensuring accuracy of duplication and good workmanship. The Howden boiler is adapted to work safely and economically under the highest air pres-

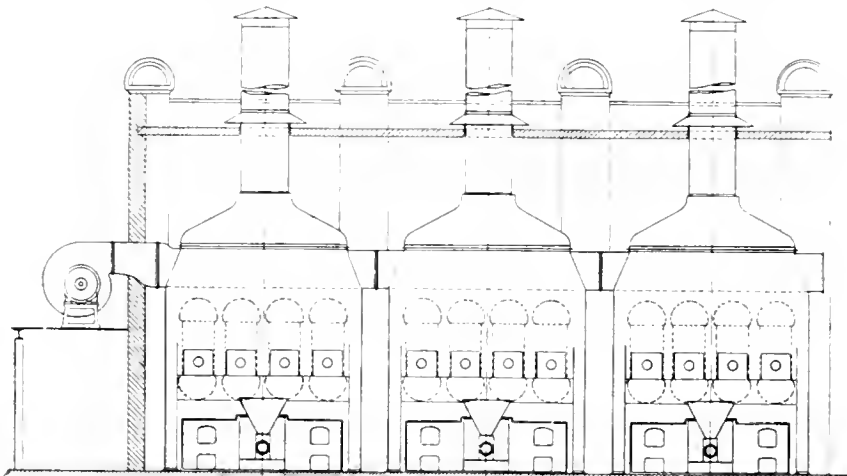

FRONT ELEVATION OF "HOWDEN" BOILER INSTALLATION AT BOROUGH OF BERMONDSEY ELECTRIC LIGHT STATION

sure of the Howden system of forced draught, and at the highest steam pressures now employed.

All parts of the boiler when working are under an equal heat, that is, no one

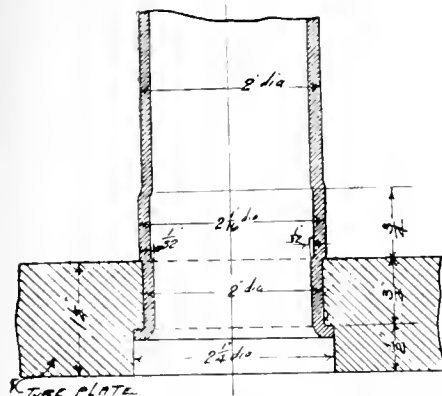

DETAIL OF TUBE FASTENING IN TUBE PLATES

Tubes cutter and extractor should be used for withdrawing tubes when possible, but if hand chisel be used, great care must be taken so as not to injure tube plates.

place is hotter or colder than another, while, in raising steam from cold water, all parts are brought under heat at the same time. The design lends itself to a rapid positive natural circulation without piping or other adjuncts, also to internal self-cleansing in the water tubes and drums where the water is in continual rapid movement over the surfaces exposed to the hot fire gases. In the matter of accessibility, attention is called to the fact that in a four element boiler, by the removal of eight manhole doors, the whole of the internal working parts of the boiler, that is, top and bot-

tom drums and tubes, are at once open for examination when necessary. The fact that the tubes are short and straight is a matter of much importance, as they can all be examined in each element in a few minutes.

For outside examination, the side portable doors can be quickly opened or removed, also the smokebox doors; and further, the combustion chambers are accessible by manholes from their underside, from which the back and tubes can be examined. Tubes can be removed and replaced quickly, the method of doing so being illustrated, as also the scheme of their fixing in the drum tube-plates.

In the fitting of Howden boilers into steamships, important savings are effected. Vessels which are to have cylindrical boilers installed cannot be finished completely at the yard in which they are built, as marked spaces in decks and upper works above the boiler rooms must be kept open, not only for purpose of lowering heavy cylindrical units into place by crane after launching, but the work must be finished in such a way after the boilers are on board that these decks and upper works may be opened up again to remove the boilers when they are worn out or damaged, which always takes place after

a longer or shorter period of service, and in order to refit the vessel with new boilers. In large high power steamships, the cost of opening up and reclosing deck work, etc., together with that for crane service, amounts to a large sum. In the case of the Howden boiler, the several parts can be put on board by either the shipyard derricks or those of the vessel herself, being afterwards lowered to place for erection, through the stockhold lathways or the funnel opening.

The Howden boiler may be equipped with chain grates or other mechanical stokers for land installations and may be operated under either forced or natural draft, although necessarily only with

the former can the highest economy and power be obtained. The boiler patents include a superheater of simple and efficient design integral with the structure of each generating unit, also

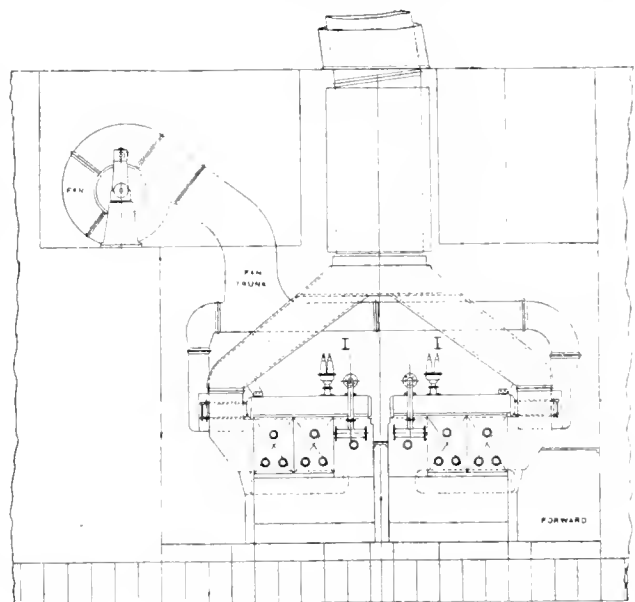

SIDE ELEVATION OF "HOWDEN" BOILER INSTALLATION ON BOARD SHIP.

a feed heater or water back forming part of the boiler evaporative surface, which is specially suitable for naval installations where reduction of weight and increase of tube surface and power in a given space are of material importance. When superheated steam is not required, the superheater can be immediately converted into ordinary heating surface, and thereby increase further the evaporative capacity of the boiler. From the illustrations accompanying, no difficulty will be experienced in grasping the detail features which go to make up either individual or combination units.

Test of No. 1 "Howden" Boiler

Heating Surface	3,125 sq. ft.
Grate Area	54 sq. ft.
Duration of Test	6 hours
Coal Burned (Bituminous Scotch)	11,058 lbs.
Coal Burned per Hour (average)	1,803 lbs.
Coal Burned per sq. ft. Grate	34.1 lbs.
Total Ash and Clinker	1,120 lbs.
Ratio of Ash and Clinker to Coal Fired	10 %
Total Water Evaporated	107,100 lbs.
Water Evaporated per Hour (average)	17,850 lbs.
Water Evaporated per lb. of Coal as fired under 192 lbs. pressure	9.68 lbs.
Water Evaporated per lb. of Coal as fired from and at 212 degs. Fah.	11.38 lbs.
Water Evaporated per lb. of Combustible at 192 lbs. pressure above atmosphere	10.7 lbs.
Water Evaporated per lb. of Combustible from and at 212 degs. Fah.	12.58 lbs.

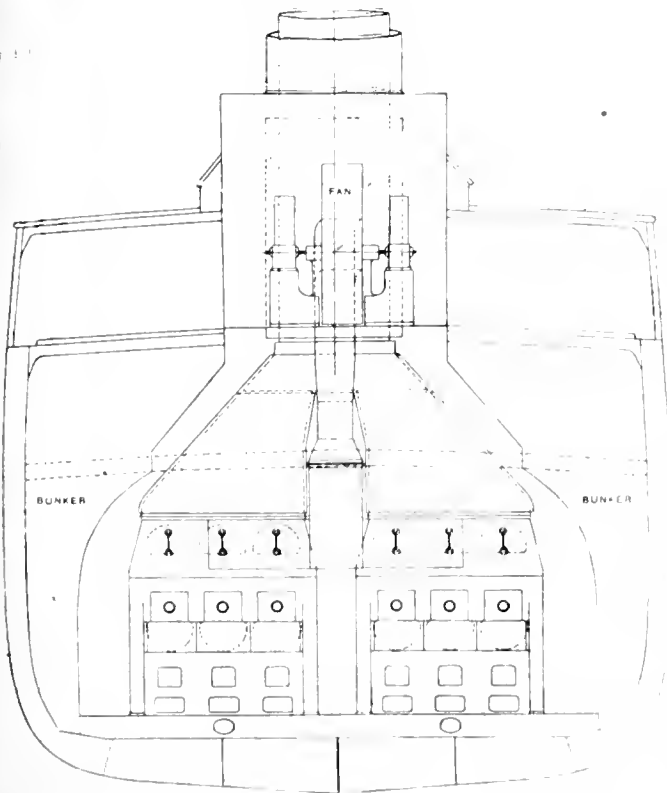

FRONT ELEVATION OF "HOWDEN" BOILER INSTALLATION ON BOARD SHIP.

Steam Pressure ... 192 lbs. per sq. in.
 Feed Temperature entering Boiler • (Water Heated with Live Steam from Boiler) ... 97 degs. Fah.
 Temperature of Water in Feed Tanks 59 degs. Fah.
 Funnel Gas Temperature 473 degs. Fah.
 Temperature of Gases Entering Air Heater 545 degs. Fah.
 Temperature of Air in Reservoir 196 degs. Fah.
 Atmospheric Temperature at Fan 72 degs. Fah.
 Air Pressure at Fan 2 $\frac{5}{8}$ inches
 Air Pressure in Ashpit 1 $\frac{1}{4}$ inches
 Air Pressure in Furnaces $\frac{1}{2}$ inch
 Moisture in Steam (by Barrus Calorimeter) ... About 1%
 Flue Gas Analysis, C.O₂ 14.8%
 Flue Gas Analysis, C.O Nil.
 Flue Gas Analysis O. 4%
 Funnel 3 ft.-8 in. in diameter, 34 ft. in height above uptake, and 50 ft. above fire grate.

Steam was disposed of during the trial by blowing off into the atmosphere. Ashes were cleaned from ashpit forty minutes preceding the start of the test, and all observable clinker removed at that time. The fires burned freely, very little smoke being observed, and that only when firing.



BALL BEARINGS IN THE WOODWORKING INDUSTRY

TEN years ago ball bearing wood-working machines were a luxury. Very few were in use, because they were not needed, but labor cost began to climb and with it the construction of woodworking machinery underwent a complete change. Manufacturers demanded more work; production had to be increased to offset high expenses. This meant that each machine had to work at higher speed, and with heavier cuts. Immediately there was trouble. Bronze bearings which had been satisfactory, showed unexpected weaknesses. Hot boxes, burn-outs, and rapid wear were the rule. Evidently it was necessary to find some type of bearing which would stand up under heavy duty. After considerable experimenting some manufacturers turned to ball bearings, and their doing so marked the advent of ball bearings in woodworking machinery. From the very start they proved their ability to stand up to the most exacting requirements. Aside from this, however, ball bearings brought a host of advantages, among which were better work, more work, less power, less oil, cleanliness, freedom from hot boxes, reduced fire risks and lasting accuracy.

The advantages of ball bearings for woodworking machinery are: Reliability at high speeds; increased production; improved quality; accuracy of bearing detail; reduced maintenance; reduced number of accidents; bearing troubles minimized. A brief consideration of these points will prove each advantage clearly.

Reliability at High Speeds

It is plain that ball bearings would not be used if they were unreliable at high speeds, because makers and users demand speed. Ball bearings were tried when bronze bearings failed. After ten years of real service they are in use in most types of woodworking machinery and this is the proof of their reliability at high speeds.

Increased Production

A knife rotating 8,000 r. p. m. makes many more cuts a minute than a knife rotating 5,000 r. p. m. This is one reason why ball bearings increase production—they allow higher speeds and more cuts per minute. It has also been found by practical experience that ball bearings give a great reserve power to the machine by reducing the power wasted in friction, therefore, machines equipped with ball bearings can take heavier cuts. This is particularly noticeable in such machines as planers and shapers. A ball bearing shaper will easily take cuts that are heavy enough to stall a bronze bearing shaper.

Improved Quality of Work

Users soon found that the quality of work done on ball bearing equipped machines was better and more uniform than that done on plain bearing machines. There are reasons for this. First, ball bearings are extremely accurate; a wheel, a cutter cylinder, or an arbor mounted in ball bearings can be adjusted with a high degree of accuracy. Second, ball bearings are self-aligning; any bending of the shaft is taken up by them. The bearing itself is so constructed that, without any special housing, it will compensate for shafting that is out of line. It is also practically impossible to bind a ball bearing; the shaft runs freely in any position. It is well to remember this, because no matter how much care is taken, sudden loads and uneven pulls will cause bending and deflection of shafts. High speed also improves quality because high speed means more cuts per minute, resulting in cleaner cut work.

Bearing Detail Accuracy

Ball bearings are made of high-grade materials, heat-treated in the most modern way and ground accurately to the ten thousandth part of an inch. The accuracy is lasting. Hardened steel balls rolling on hardened steel races practically eliminate all wear. Ball bearings put in woodworking machinery in 1907 are running today and are still giving the same care-free, reliable service, as when new.

Reduced Maintenance

Due to their low friction, ball bearings are very economical to use. The power saved can be turned to other work and the saving made will show up in actual money. Ball bearings save oil. They use very little, only a small fraction of the oil used by plain bearings, the bearing being so housed that it will hold enough oil to last for months. Furthermore, the housing is oil-tight, so no lubricant can be lost by leakage. An oil

tight housing also means a clean machine, a clean plant, protection from fire risk due to oil soaked waste and "live" belts unspoiled by oil.

Belts on ball bearing equipped machines last much longer, because they do not run high tension, and are free from oil. Also, the machines start easily, the bearings do not stick, and there is no excessive tension when starting. All of the above help materially to lengthen the life of belts. If motors are equipped with ball bearings, another big saving is effected. The motors use little lubricant and are largely free from many troubles that often tie up production. Ball bearings are practically wearproof, so there is no need of replacing worn bushings. The danger of worn bearings allowing the armature to touch the pole pieces is in consequence entirely avoided.

Reduced Number of Accidents

Poorly adjusted bearings, play, hot boxes, pools of oil—all are frequent causes of accidents or fire, and all are eliminated by ball bearing installation. The parts are carried in correct adjustment and the bearings themselves are non-adjustable; no adjustment is necessary. Play is the result of wear. Hot boxes may be said to be unknown where ball bearings are used. The bearing is constantly bathed by oil, and since there is no friction there is also no heat. Fires from this source are therefore effectually prevented. Another source of fire is oil-soaked waste. Sawdust or shavings soaked with oil have been the start of many fires. By using ball bearings, housed perfectly oil-tight, this danger is removed. Pools of oil that collect dirt and leave slippery spots are a constant source of danger.

Some of the advantages mentioned here are more important than others, also some of them are more marked in one type of machine than another; but no matter what the machine is, the service and advantages gained by equipping it with ball bearings are certain and great. A prominent manufacturer of woodworking machinery who is a large user of ball bearings has expressed his opinion very clearly in one of his folders, thus:—"Steel ball bearings have so many advantages over both bronze and babbitt bearings then the manufacturer who once uses them will be satisfied with nothing else, provided of course that the ball bearings in the particular machine he is using are of the highest grade and of the best type procurable."

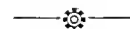

Nationalization in India.—A notification has been gazetted in India providing that where the output of any mine or industrial concern can be utilized in connection with the present war, the Governor-General in Council may require the owner, or any person in charge of such mine or industrial concern, to place it at the disposal of the Governor-General, who may use it in such manner as he may consider necessary or expedient.

EDITORIAL CORRESPONDENCE

Embracing the Further Discussion of Previously Published Articles, Inquiries for General Information, Observations and Suggestions—Your Co-operation is Invited

MACHINISTS' INSTRUCTION COURSE—XXI.

By J. Davies

THERE is quite a number of difficult ways of setting up a milling machine for round work held between centers, that is, to set the cutter central, but it cannot be said that any

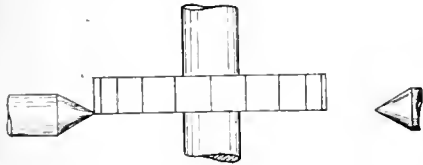

FIG. 78.

particular method is the best. A method suitable for one job, might be altogether unsuitable for another; it depends on the character of the work and the degree of accuracy required. A method that is near enough for some jobs is to bring the edge of the cutter in line with the point of the center before the work is put between the centers, then move the table over, half the thickness of the cutter Fig. 78; this will bring the cutter central. A slower but probably a more accurate way, is to start up the machine and take a few small cuts across the work, until you have machined a spot the width of the cutter. The cutter is now set central with the spot machined and will be very nearly central with the center of the job Fig 79—or you may set a try square on the table against the side of the work, and adjust the cutter until it calipers the same distance at each side from the edge of the square to the side of the cutter, Fig. 80.

Straddle Mills and Gang Cutters

Straddle mills are usually adjusted for width by placing washers between the cutters. Never use more than one washer, collar, or distance piece if it can be avoided—fine adjustment can be obtained by using paper washers. Adjustable distance pieces are sometimes used, that is one piece threaded with a fine thread to fit inside another piece, but

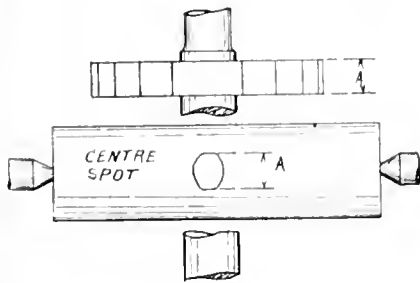

FIG. 79.

it is preferable to have a plain solid distance piece. It is necessary that the washers should be true sideways that is

equal thickness all round. If not, when they are tightened up on the arbor the cutter will be untrue. In placing gang mills on the arbor put them on in such a manner that the cutting edges will not be in the same line—this distributes the cut better, breaks up the chips and is easier on the machine.

Taper Work Between Centers

The correct way to set the centers for milling taper work, is to have the axis of the index head spindle, coincide with the axis of the dead spindle irrespective of their relation to the line of motion. When this is the case the work will always be in true alignment with center, there will be no side motion to the tail of the dog during the revolution of the work and it will be possible under these conditions to divide tapering work into equal divisions. In some cases it is not possible to set the centers correctly in line owing to the construction of the center attachment.

When the axis of the work and the axis of the index spindle are at an inclination to each other, we have the same condition as in the lathe when turning taper with the tailstock set over, instead of using the tapering attachment. This has been fully described under the heading of lathe work; suffice it to say here that when the angular movements of the work and index spindle are not equal, it is impossible to obtain equal divisions. It is necessary to fasten the tail of the dog with a set screw to prevent any lost motion. When there is any axial movement to the tail of the dog, as there would be in the case just described, it is necessary to loose the set screw before moving the work and tighten up again after moving the work around the required amount. This will prevent springing of the work, but will not ensure equal divisions.

In some designs of index heads and tailstocks, the index head can be moved around in a circle, or part of a circle and is raised to point upward. The tailstock spindle has an adjustment up and down and may be raised until it coincides with the axis of the index spindle; that is to say when the axis of index spindle and the axis of the work agree, correct divisions may be obtained independent of the alignment of the tailstock center, Fig. 81

Aligning Work With Spindle

A very simple and practical method to test the alignment of the work with the index spindle is as follows: Put the face plate on the index spindle, and a common lathe dog or clamp on the work. Fasten the dog on to the work and adjust it so as to leave just room enough to pass a piece of paper between the end of the dog and the faceplate,

Turn the work round and try the paper at each quarter turn, adjusting until the tail of the dog pinches the paper with the same degree of tightness at each point, when the work must of necessity be in line with the index spindle. There is one precaution to be observed in a set up of this kind. When machining a number of pieces supposed to be all alike, the least variation of length, or even in the depth of the center holes, will throw the work out of line, and cause the divisions to be unequal and the taper different. In most cases of repetition work the amount of error would be a negligible quantity but if the work were required to be as accurate as possible, every separate piece would have to be tested. If the cut is to be taken parallel to the surface of the work, that is a cut of equal depth, test with a surface gauge from the table before starting the cut. If the cut is to be deeper at one end than the other, just touch with the surface gauge or the cutter itself at the high end, then try the other

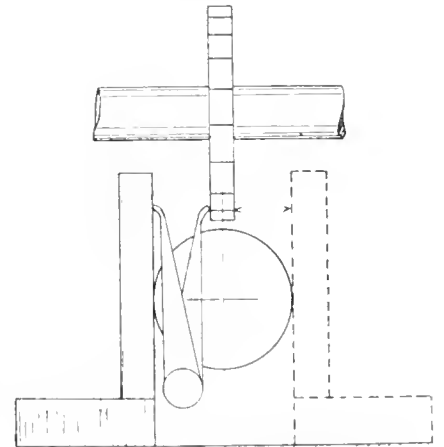

FIG. 80

end and measure or caliper the difference; or make a little wire gauge to represent the difference of the depth of the cut, and place the wire gauge under the pointer of the surface gauge at the low end, letting the gauge just touch the work at the high end.

Indexing

When a piece of work must have a definite number of cuts taken across its surface, such as a gear with a certain number of teeth, or a reamer or anything that needs to be accurately divided, the index head is invariably used. There are many designs of index heads varying in details and arrangement, but the principle involved is common to all. A worm and worm wheel are usually employed, so that it requires 40 turns of the crank which is fastened to the end of the worm shaft, to rotate the work that is between the

centers one revolution. In order to measure parts of a revolution, an index plate is fitted to the end of the worm shaft, but does not rotate with it, being prevented from doing so by means of a stop pin fitted to the frame. This plate has a number of concentric rows of holes, and in each row a different number of holes. The crank is adjustable up and down and can be made to coincide with any one row of holes, and is kept in position by a spring latch pin which is fitted to the crank. Most manufacturers supply tables with their index heads that give most of the divisions required, but every mechanic ought to know the reason why and be able to figure it out for himself. Although as just stated they are usually constructed so that it requires 40 turns of the worm shaft for one of the job, this is not necessarily always the case.

Figuring the Holes

The first thing to do is to find out by actual trial the number of revolutions for one turn of the work. Let us suppose that 40 revolutions of the worm shaft give one turn of the work, then it is evident that one turn of worm shaft would give 1-40th of a turn of the work and would divide the work into 40 equal parts. From this we deduce the following rule: Divide 40, (or the number of turns required for one turn of work) by the number of divisions into which the work is to be divided, and the re-

holes, then the number of holes required for the fractional part of the turn would be $15 \frac{1}{3} \times 1,3 = 5$ holes. So that by using a 15 hole circle the right division would be 3 complete revolutions and 5 holes.

To Prove Calculations

Since every job will be completed when the index crank has made 40 revolutions, multiplying 40 by the number of holes in the circle used, will give the total number of holes used to complete the job, which in this case would be $40 \times 15 = 600$. Now divide by the number of holes used for each division, in this case $15 \times 3 \frac{1}{3} = 50$. The result will give number of divisions $600 \div 50 = 12$ divisions.



MATERIAL AND MECHANISM

By A. L. Haas.

THE entire economy of the mechanical profession divides neatly into halves, and the problems represented are nearly equal in value. Which section is the most important it is difficult to say and, indeed, perhaps idle to conjecture.

The ramifications of mechanism are well nigh inexhaustible; though, in the hands of a capable exponent, nearly every combination is reducible to a relatively small number of well-known elements.

The material field has been greatly broadened in recent years, yet it is this

qualities are uniformity, ease of working and similarity.

Coming to a more practical view of quality, or rather a quality,—hardness is relative both with regard to temperature and ingredients, method of working in production, etc., and is the product of a series of complex phenomena. Coupled with fragility under shock and unstable internal stress, it may at times be an undesirable element.

One fact comparable to the conservation of energy, theory is a realized fact today. A single quality, in a superlative degree, in a material can only be obtained at the expense, and by the sacrifice of, other qualities. Nor can the steel maker, held to a rigid analysis, be expected to furnish material with rigid physical characteristics. If the physical qualities—tensile strength, elongation, reduction of area and yield point be specified, it is folly to add to these the chemical ingredients and hold the maker to both sets of test conditions. You may have either, but not both. Yet the fact remains that orders are issued containing such impossible conditions. The maker of material has reason to dread their advent and in some instances refuse to fill both analysis and physical tests.

Losses Balance Gains

In a single material, without alteration of ingredient, if the tensile strength be raised, the elongation or reduction of area suffers. Cold rolling will do the trick and render the material more fragile because less ductile.

The outstanding metallurgical fact is that by the introduction of new ingredients in, sometimes, minute quantities super-excellence in some one direction is assured.

Perhaps we are on the eve of obtaining by such application of research, materials with dependable qualities in two or more directions. The materials at present relied upon are specialized to particular ends.

We know little after all of the basic composition of matter, and however physicists theorise, it seems one of the most elusive of problems and as yet far from solution.



HOW THE MOVING PICTURE FILM GETS ITS MOTION

By D. A. Hampson.

A MOTION picture film is a celluloid strip about $1\frac{1}{2}$ ins. wide and hundreds or thousands of feet in length, crowded its whole length with thousands of small negatives, just the same as would be made in a little camera of $\frac{3}{4}$ in. x $1\frac{1}{4}$ in. size. There are sixteen of these negatives to a foot of length, and so rapidly have they been "snap-shotted," we will say, that a careful observer can see little if any difference between any of the sixteen in a given foot; it is only when a comparison of negatives quite a distance apart is made that a difference is noticed and one begins to comprehend that a progression is occurring and a scene is being unfolded.

The person who, for the first time observes what slow progress he makes with

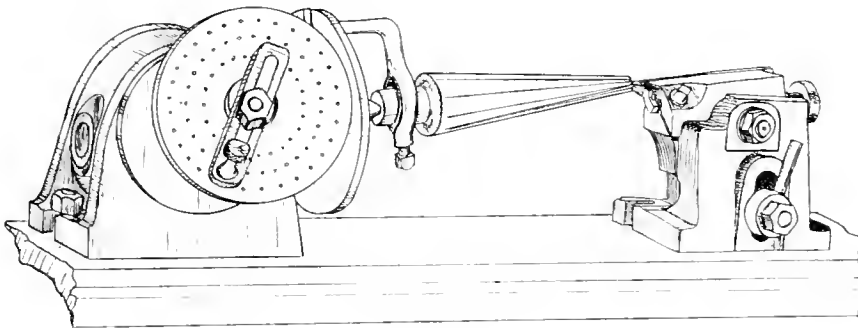

FIG. 81.

sulting fraction will give the number of turns, or parts of turns which the index crank must make to obtain the desired result. Example.—It is required to cut a gear with 20 teeth; then according to rule, $40/20 = 2$, complete turns. Example 2—How many turns must the crank make to divide the work into 12 equal parts $40/12 = 3 \frac{4}{12}$ or $3 \frac{1}{3}$. The question now arises how can we tell when we have moved the index crank around $1\frac{1}{3}$. After reducing the fraction down to its lowest terms, select a circle that is divisible without a remainder by the denominator of the fraction. Multiply the number of holes in this circle by the fraction, to obtain the number of holes the crank must be moved for the fractional part of a turn required. Thus $40/12 = 3 \frac{4}{12}$ or $3 \frac{1}{3}$. According to rule select a circle divisible by the denominator of the fraction $1\frac{1}{3}$, that is 3. Suppose we use the circle with 15

end of the business which presents many awkward problems to the machine shop.

An average engineer or designer, though directly concerned with materials, has generally little to do with its production. He is concerned with quality and choice, not with material as such, and hence is a selector only.

Science Aids Commerce

Purchasing departments are mostly concerned with the consideration of costs and their attitude is commercial. From dearly-bought experience, many large concerns now enlist the services of the metallurgical expert who can chemically and physically exert a check upon uniformity and desirable qualities. It is a business needing tact and discrimination, and the pure scientist is apt to discover the need for a commercial aspect to his work. Obviously nearly anything may be had at a price, but uncommercial material is usually at prohibitive prices. The desired

a scene when looking over a film in his hand, cannot fail to appreciate the rapid rate at which the film must run through the projecting machine in order to reproduce the scene in a life-like manner.

Not a Magic Lantern

Most of us have a general idea that this machine is a sort of glorification of the magic lantern of our youth brought up to date by electricity and mechanical

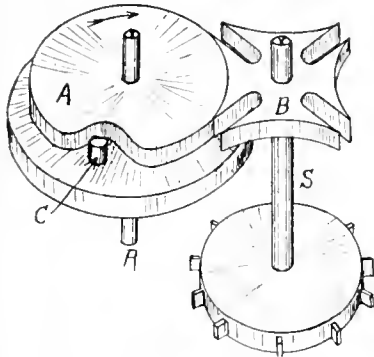

FIG. 1. DETAIL CONSTRUCTION OF GENEVA STOP MECHANISM.

movements so wonderful that it takes a skilled operator to run one. It is very true that if a film is in the machine and is held stationary, a picture from that negative will be thrown upon the screen just as would one from our primitive lantern slide—a noticeable difference being that the film is run through in and up and down direction instead of horizontal. Moreover, in the modern machine the film travels at a rate that carries about 800 individual negatives per minute through it—a rate so high that without some very ingenious mechanism intervening there would be nothing but a swath of blur moving down the screen. What, then, is this mechanism that rises superior to blur and high speed and countless pictures having no perceptible difference?

What is called a "Geneva" gear is the important part of every projecting machine; it is a motion that (through the aid of other parts) draws the film along, stopping it momentarily when each picture or negative is in front of the lamp only long enough to allow a clear enlargement of it to be thrown on the screen and then, with a jerk that is discernible to the spectator only as a slight flicker, draws it just the height of another negative and brings it to a positive stop. This is done eight hundred times a minute, thirty minutes at a stretch, and always ready for the next roll. This Geneva gear is indeed a triumph, but not a modern one except in its refinements, for in textile mills we find looms bearing a date long "before the war" that are still doing business with the original Geneva in a fair state of preservation.

Action of Geneva Stop

Referring to the drawing, R is a shaft driven at a constant speed all the time, carrying one member of the Geneva gear A, which through the pin C drives a member B on the shaft S, which in turn draws the film through the machine. But while the shaft R revolves four times,

the shaft S has made but one revolution and during that one it has been started and stopped four times—this is the motion that is transmitted to the film.

The member A is a disk whose periphery is broken for a short section opposite the pin C, which is rigidly set in the flange of the disk. Concave faces on the member B rest against the periphery of A, and during this period of rest, the shaft S and the film are stationary. Between the concave faces are slots, and as the disk A revolves, the pin C runs into one of them, moving the (so-called) star wheel B a quarter revolution. The movement of B is only possible because of the cut-out section of A opposite the pin. This is the motion that runs so faithfully hour after hour. Of course, the materials have to be of the best, the gears run in oil, and the shafts set for perfect meshing of the parts: in its present perfected state it looks very simple. The gear and shaft ratio is varied on different machines, but the one shown of one to four is generally used.

Location of Stop Gear

To make the working of the machine a little more clear, a part of the related mechanism is shown in Fig. 2. Here is shown a portion of the main frame of the entire machine, and also the oil-tight case enclosing the Geneva gear. The same intermittent shaft S extends out from the case and carries on it two sprockets which have a special form of teeth engaging holes in the film. There is a row of these holes of exactly the same spacing on each side of every film made and it is by means of these holes and sprockets that an accurate, positive movement of the film is obtained from the equally positive Geneva gear. This describes the salient features of the motion picture projecting machine of today; there are gears and lenses and

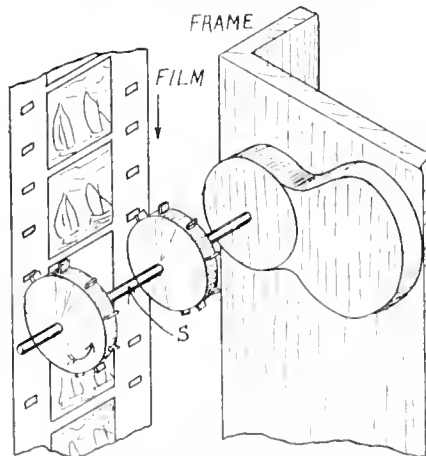

FIG. 2. SHOWING ARRANGEMENT OF GENEVA STOP MECHANISM AND FILM.

lamps and fire shutters, but they are of only passing interest. It might be added that one of the heaviest losses of the films themselves occurs from tearing, which comes from the action of the metal sprocket teeth jerking the light strip of celluloid. A torn film is valueless and though inventors have worked on some other forms of positive drive, they have so far been unsuccessful.

THE FUEL VALUE OF PITCH

By O. C.

BEFORE the war a very large part of coal tar pitch produced in Britain was exported, but since August, 1914, this outlet has been more and more restricted and the consequence is that huge accumulations of pitch are encumbering the working up of high explosives, munitions of war at coke ovens, gas works, and other tar distilleries. Prospective new outlets for use in gas and briquette making have not yet materialized to any appreciable extent, and as the rate of output is now more than 1,000,000 tons a year, the possibility of using pitch as a fuel for steam boilers and other furnaces demands consideration. Not only is its calorific value, viz., 15,500 to 15,500 B.t.u. per lb.—higher than that of the best quality Welsh steam coal—but its present price in the Midlands and London districts respectively, is only about one-third to one-half that of such coal; moreover, it is practically pure carbon, and ash and moisture free, so that in whatever proportion it may be added to other staple fuels, more than an equivalent amount of such fuel may be released for sale export.

Obviously, pitch cannot be burned on fire-bars designed for coal. The chief difficulty experienced in attempting to burn pitch has been the low fusing and volatilising temperature common to all pitches; and the consequent tendency to separate carbon in the form of dense smoke. Compared with average bituminous coal containing 28 per cent. volatile matter, pitch contains about 55 per cent., the remainder being practically pure amorphous carbon.

Experiments have been recently conducted, however, with a view of arriving at a simple and inexpensive form of grate which would answer the purpose, and as a result it is claimed that a method has been found whereby coal-tar pitch may be consumed in conjunction with coke with considerably less than the ordinary amount of smoke observed at the chimney of a coal-fired boiler. The *modus operandi*, which has been tried with some success in certain gasworks boilers, is to substitute a number of "pitch" bars for an equivalent number of existing fire-bars in a boiler furnace fitted with steam jet forced-draft apparatus of ordinary construction. Pitch, broken to any convenient size, is fed on to the pitch bars, where the heat of the surrounding fire causes it to collect and volatilize; the rate of such volatilization being controllable by means of the special formation of the pitch bars, within limits which ensure practically smokeless combustion. The partially coked residue remaining after the more volatile constituents have been burnt off is periodically raked on the rear portion of grate, where its combustion is completed.

AN increasing number of useful organic drugs, including alkaloids, is now made synthetically from other chemical substances. Many of these are unknown in nature, their production and utilization being solely due to science.

The MacLean Publishing Company

LIMITED

(ESTABLISHED 1888)

JOHN BAYNE MACLEAN - - - - - President
H. T. HUNTER - - - - - Vice-President
H. V. TYRRELL - - - - - General Manager

PUBLISHERS OF

CANADIAN MACHINERY AND MANUFACTURING NEWS

A weekly newspaper devoted to the machinery and manufacturing interests.

PETER BAIN, M.E., Editor. B. G. NEWTON, Manager.

Associate Editors

A. G. WEBSTER J. M. WILSON J. H. RODGERS

Office of Publication, 143-153 University Avenue, Toronto, Ont.

Vol. XVII.

JUNE 7, 1917

No. 23

PLANT REFERENCE LIBRARY

A FACTOR likely to have considerable bearing upon the increased productive power of manufacturing plants, would be the establishment of a works library, in which a quantity of technical books and other literature would be available for ready reference for those officials who might be confronted with difficult problems pertaining to their particular class of work. These libraries would not require to be stocked with a wide range of subjects, but preferably a quantity of books and periodicals containing a comprehensive record of previous and current practice in the particular lines of activity in which the various plants are engaged.

While the available books would be primarily for reference purposes by the various department heads, the opportunity should be provided for the loaning of these books to any employee desiring same for study. By encouraging the workmen to take a greater interest in the technical features of their daily labors, it would not only increase their productive efficiency but also their earning power; and at the same time provide a means of developing trained men that would take a keener interest in the work they are doing. The returns from a reference library of this nature should more than repay the expense entailed by installation and maintenance.

EFFICIENCY THROUGH CO-OPERATION

APPARENTLY, the keynote of successful manufacture of the present day is based on the principle of efficiency, yet the fact that this efficiency must vary to a great extent in every individual and likewise every industry, makes it the more difficult to understand and also to define. From the dictionary we learn that the meaning is resolved into the ratio of the work performed to the energy expended, and while this applies more in the terms of mechanical work, the same is applicable to achievement of any or every kind. Individual efficiency, however, is the striving to accomplish what is required of you with the least expenditure of energy in the least possible time and with the most satisfactory results; and while this is true in the case of personal ability, the effect is the same in all lines of industrial activity, for the entire

problem is mainly one where the human factor is the chief essential. With the individual, this trait of utilizing the full power to produce can only be acquired by stirring up the latent energies of the mind and body—the latter, in many instances, does not respond readily to the activities of the former, and adapting these energies to the best possible accomplishment of the desired objective. In the case of industries, great or small, maximum efficiency is only possible by the development and maintenance of this important factor in every individual workman.

Many manufacturing plants in the past have been impressed with the idea that their efficiency has been the result of adopting certain methods in the manufacture of their product, the secret of which they have been able to withhold from others in the same business, thus being able to advance more rapidly than the other. While this may be true in some cases, such an idea of efficiency is becoming exploded by the more broad-minded one of mutual co-operation and the interchange of ideas. If the old order of things had prevailed during the past three years of abnormal activity, every manufacturer relying on his or their own ability and resources for the development of the shell industry, the success of this industry would undoubtedly have been far below what actual results have proved.

The magnitude of recent munitions activity throughout the entire Dominion has clearly shown that to attain maximum efficiency both in the individual and in the operation of the plant, it was most essential that every facility be provided for maintaining production at the highest possible figure, and in order to do this it was found advisable, in fact necessary, to have a free and unrestrained exchange of thought and ideas regarding the best methods of achieving a certain end. It therefore follows that the highest efficiency in any line of endeavor can only be attained and maintained by the mutual co-operation of every one connected with the origination, progress and achievement, of every line of thought and action.

We speak of a machine in terms of efficiency, yet it depends almost entirely upon the operator what this term really implies. When a man is kept employed on a certain machine for any length of time, his effectiveness will naturally increase in proportion to the interest he takes in his work and also the nature of that work. If, however, the nature of the work is such that monotony is a feature of its continual operation, the efficiency of the machine may remain constant, but the actual production may be lessened, due to the laxity of the man working it. This has been offset to some extent by the introduction of the piece-work system, whereby a workman is encouraged by possible additional remuneration for greater production. On the other hand, where the nature of the work calls for the closest concentration in the accomplishment of same, and where the accuracy of the work depends more on the operator than on the machine, the individual workman and eventually the shop in which he is employed, may find themselves traveling in a rut with their relative efficiency unchanged, but at the same time falling below that of the other plant which has brought itself to recognize the increased possibilities by adopting methods whereby certain operations can be improved or production increased.

Efficiency is a flexible term when applied to production; its value may change from day to day as a result of many causes or a combination of several, but it is safe to say that the chief essential in maintaining a constant and gradual increase in operating efficiency is the closer co-operation of individual activity and the freer interchange of ideas between the men in each shop and with those of other shops, the latter being made more effective through publication in the editorial columns of their trade and technical journals.

INDUSTRIAL NOTABILITIES

WILLIAM EVELYN VALLANCE, director, Carbon & Alloy Steels, Ltd., Hamilton, Ont.; director, Wood, Vallance & Leggatt, Ltd., Vancouver, B.C.; director, Wood, Vallance & Co., Ltd., Winnipeg, Man.; director, Ontario Motor League, was born in Hamilton, Jan. 27, 1884, son of William and Marie (Phelps) Vallance.

After receiving his education in private schools at Hamilton, and Trinity College School, Port Hope, Ont., Mr. Vallance began his business career with Wood, Vallance & Co., Hamilton, 1901-1916.

In the latter part of 1916 Mr. Vallance, along with Mr. H. J. Waddie, President of the Canadian Drawn Steel Co., organized Carbon & Alloy Steels,



WILLIAM EVELYN VALLANCE.

Ltd., operations at present being carried on at the Moffat Irving Steel Works, Toronto, preliminary to moving that plant to Hamilton, where the production of alloy steel castings will be engaged in.

Mr. Vallance holds a commission as Lieutenant in the 13th Royal Regiment, Hamilton. He married Arvilla Adelaide Gurney, daughter of Charles Gurney, Oct. 19, 1910, the family consisting of two sons.

His societies are: A.F. & A.M.; while he is also a member of the following clubs: Hamilton: Thistle; Hamilton Golf; Canadian; Caledon Mountain Front; Waterloo Golf & Country (Galt).

In politics he is Conservative and in religion, Presbyterian.

Mr. Vallance's residence is 228 Bay Street South, Hamilton, and his country home is "The Croft," Burlington, Ont.

Photo, Courtesy British and Colonial Press.

SELECTED MARKET QUOTATIONS

Being a record of prices current on raw and finished material entering into the manufacture of mechanical and general engineering products.

PIG IRON.

Grey forge, Pittsburgh.....	\$49 95
Lake Superior, charcoal, Chicago	50 25
Standard low phos., Philadelphia	75 00
Bessemer, Pittsburgh.....	45 95
Basic, Valley furnace.....	42 00
Montreal Toronto	
Hamilton.....	50 00
Victoria.....	50 00

FINISHED IRON AND STEEL.

Per 15. to Large Buyers Cents

Iron bars, base, Toronto.....	5 00
Steel bars, base, Toronto.....	5 25
Steel bars, 2 in. to 4 in. base	6 00
Steel bars, 4 in. and larger base	7 00
iron bars, base, Montreal ..	4 75
Steel bars, base, Montreal..	5 00
Reinforcing bars, base.....	5 25
Steel hoops, Pittsburgh.....	7 00
Bessemer bars, heavy, at mill	38 00
Steel bars, Pittsburgh.....	4 00
Tank plates, Pittsburgh.....	7 00
Beams and angles, Pittsburgh	4 00
Steel hoops, Pittsburgh.....	4 25
F.O.B., Toronto Warehouse.	
Steel bars, base.....	5 25
Small shapes.....	5 50
F.O.B. Chicago Warehouse	
Steel bars.....	4 50
Bars, 2 in. and up.....	4 65
Structural shapes.....	5 00
Plates.....	7 00

FREIGHT RATES.

Pittsburgh to Following Points	Per 100 lbs	C.L.	L.C.L.
Montreal.....	23 1	31 5	
St. John, N.B.....	35 1	45 5	
Hullfax.....	35 1	45 5	
Toronto.....	18 9	22 1	
Guelph.....	18 9	22 1	
London.....	18 9	22 1	
Windsor.....	18 9	22 1	
Winnipeg.....	64 9	85 1	

METALS.

Montreal Toronto	
Lake copper.....	\$38 50 \$37 00
Electro copper.....	38 50 37 00
Castings, copper.....	37 50 36 00
Tin.....	62 50 66 00
Spelter.....	13 50 12 00
Lead.....	13 50 14 00
Antimony.....	26 00 30 00
Aluminum.....	70 00 68 00

Prices per 100 lbs.

PLATES.

Montreal Toronto	
Plates, 1/4 to 1/2.....	\$10 00 \$10 00
eads.....	10 30 10 30
Tank plates, 3-16 in.....	10 10 10 10

WROUGHT PIPE.

Effective May 14, 1917.

Black Galvanized	
Standard Butt weld.	
Size.	Per 100 feet
1 in.....	11 73 14 88
1 1/4 in.....	15 87 20 13
1 1/2 in.....	18 98 24 06
2 in.....	25 53 32 38
2 1/2 in.....	40 95 51 77
3 in.....	53 55 67 70
3 1/2 in.....	66 24 83 25
4 in.....	78 48 98 65
4 1/2 in.....	\$ 4 50 \$ 6 00
5 in.....	4 96 7 00
5 1/2 in.....	4 96 7 00
6 in.....	6 29 7 86
6 1/2 in.....	7 94 10 05
Standard Lap weld.	
in.....	28 49 34 97

2 1/2 in.....	42 71	52 94
3 in.....	55 85	69 23
3 1/2 in.....	68 08	86 02
4 in.....	80 66	101 90
4 1/2 in.....	93 98	118 70
5 in.....	109 50	138 40
6 in.....	142 10	179 50
7 in.....	185 60	232 05
8 in.....	195 00	243 75
8 L in.....	224 60	280 80
9 in.....	269 10	336 38
10 L in.....	249 60	312 00
10 in.....	321 40	401 70

Prices—Ontario, Quebec and Maritime Provinces.

WROUGHT NIPPLES.

4" and under, 50%.	
1 1/2" and larger, 45%.	
4" and under, running thread.	
30%.	
Standard couplings, 4" and under.	
40%.	
4 1/2" and larger, 20%.	

OLD MATERIAL.

Dealers' Buying Prices.	
Montreal Toronto	
Copper, light.....	\$22 00 \$22 00
Copper, crucible.....	26 00 27 00
Copper, heavy.....	26 00 26 50
Copper wire.....	26 00 26 50
No. 1 machine com- position.....	21 50 22 00
New brass clippings.....	18 00 19 00
No. 1 brass turnings.....	16 00 16 00
Heavy melting steel.....	19 00 17 00
Steel turnings.....	8 00 8 00
Shell turnings.....	12 00 12 00
Boiler plate.....	11 00 10 50
Axles, wrought iron.....	22 00 24 00
Rails.....	19 00 18 00
No. 1 machine cast iron.....	22 00 25 00
Malleable scrap.....	17 00 20 00
Pipe, wrought.....	14 00 9 00
Scrap zinc.....	8 00 9 50
Heavy lead.....	10 50 10 75
Tea lead.....	7 50 7 00
Aluminum.....	32 00 35 00

BOLTS, NUTS AND SCREWS.

	Per Cent.
Coach and lag screws.....	25
Stove bolts.....	55
Plate washers.....	10
Machine bolts, 7-16 and over.....	net
Machine bolts, 3/8 and less..	10
Blank bolts.....	net
Bolt ends.....	net
Machine screws, fl. and rd hd., steel.....	27 1/2
Machine screws, o. and fl. hd., steel.....	10
Machine screws, fl. and rd. hd., brass.....	add 20
Machine screws, o. and fl. hd., brass.....	add 25
Nuts, square blank.....	add \$1 50
Nuts, square, tapped.....	add 1 75
Nuts, hex. blank.....	add 1 75
Nuts, hex. tapped.....	add 2 00
Copper rivets and burrs. list plus.....	30
Burrs only list plus.....	50
Iron rivets and burrs.....	17 1/2
Boiler rivets, base 3/4-in. and larger.....	\$6.65
Structural rivets, as above, 6.55	
Wood screws, flat, bright.....	.72 1/2
Wood screws, O. & R.....	.67 1/2
Wood screws, flat, brass.....	.37 1/2
Wood screws, O. & R.....	.32 1/2
Wood screws, flat, bronze.....	.27 1/2
Wood screws, O. & R. bronze.....	.25

MILLED PRODUCTS.

	Per cent.
Set screws.....	35
Sq. & Hex. Head Cap Screws	30
Rd. & Fil Head Cap Screws	10
Flat 7/8 But. Hd. Cap Screws	10
Fin. & Semi-fin. nuts up to 1 in.....	25
Fin. and semi-fin. nuts, over 1 in., up to 1 1/2 in.....	30
Fin. and semi-fin. nuts, over 1 1/2 in., up to 2 in.....	10
Studs.....	20
Taper pins.....	40
Coupling bolts, plus.....	10
Planer head bolts, without fillet, list plus.....	10
Planer head bolts, with fillet, list plus 10 and.....	10
Planer head bolt nuts, same as finished nuts.....	net
Planer bolt washers.....	net
Hollow set screws.....	list plus 20
Collar screws.....	list plus 30, 10
Thumb screws.....	20
Thumb nuts.....	65
Patch bolts.....	add 40, 10
Cold pressed nuts to 1 1/2 in.....	add \$4.50
Cold pressed nuts over 1 1/2 in.....	add \$7.00

BILLETS.

	Per gross ton
Bessemer billets.....	\$ 95 00
Open-hearth billets.....	95 00
O.H. sheet bars.....	95 00
Forging billets.....	110 00
Wire rods.....	90 00
F.o.b. Pittsburgh.	

NAILS AND SPIKES.

Wire nails.....	5 00	4 95
Cut nails.....	5 00	5 00
Miscellaneous wire nails.....	60%	
Pressed spikes, 3/4 diam., 100 lbs.....	5 30	

MISCELLANEOUS.

Solder, strictly.....	0 38
Solder, guaranteed.....	0 41
Babbitt metals.....	16 to 65
Soldering coppers, lb.....	0 53
Putty, 100-lb. drum.....	4 35
White lead, pure, cwt.....	17 50
Red dry lead, 100-lb. kegs. per cwt.....	13 87
Glue, English.....	0 38
Tarred slaters' paper, roll	0 95
Gasoline, per gal., bulk.....	0 31 1/2
Benzine, per gal., bulk.....	0 30 1/2
Pure turpentine, single bbls., gal.....	0 72
Linseed oil, raw, single, bbls.....	1 40
Linseed oil, boiled, single bbls.....	1 43
Plaster of Paris, per bbl.....	2 50
Plumbers' oakum, per cwt.....	0 00
Packing, square braided.....	0 32
Packing, No. 1 Italian.....	0 38
Packing, No. 2 Italian.....	0 30
Lead wool, per lb.....	0 15
Pure Manila rope.....	0 33 1/2
Transmission rope, Manila.....	0 43 1/2
Drilling cables, Manila.....	0 38 1/2

POLISHED DRILL ROD.

Discount off list, Montreal and Toronto.....	25%
---	-----

CARBON DRILLS AND REAMERS.

	Per Cent.
S.S. drills, wire sizes up to 52	40
S.S. drills, wire sizes, No. 53 to 80.....	25
Standard drills to 1 1/4 in.....	40
Standard drills, over 1 1/4 in.....	15
3-fluted drills, plus.....	10
Jobbers' and letter sizes.....	40
Bit stock.....	40
Ratchet drills.....	15
S.S. drills for wood.....	40
Wood boring brace drills.....	25
Electricians' bits.....	30
Sockets.....	40

Sleeves.....	40
Taper pin reamers.....	20
Drills and countersinks.....	list plus 30
Bridge reamers.....	45
Centre reamers.....	10
Chucking reamers.....	10
Hand reamers.....	15

COLD ROLLED SHAFTING.

At mill.....	list plus 40%
At warehouse.....	list plus 50%
Discounts off new list. Ware- house price at Montreal and Toronto.	

IRON PIPE FITTINGS.

Canadian malleable, A, add 10%; B and C, 10%; cast iron, 35%; standard bushings, 50%; headers, 60%; flanged unions, 40%; malleable bushings, 50%; nipples, 55%; malleable lipped unions, 50
--

SHEETS.

Montreal Toronto	
Sheets, Black, No. 28.....	\$10 00 \$10 00
Sheets, Black, No. 10, 9 50	9 50
Canada plates, dull, 52 sheets.....	8 50
Canada plates, all bright.....	9 50
Apollo brand, 10 3/4 oz.....	9 75 9 75
galvanized.....	9 75 9 75
Queen's Head, 28 B. W.G.....	10 75 10 75
Fleur-de-Lis, 28 B.W. G.....	10 75 10 75
Gal's Best, No. 28 10 25	10 25
Colborne Crown, No. 28.....	10 00 10 00
Premier, No. 28 U.S.....	8 30 9 70
Premier, 10 3/4 oz.....	8 60 10 00

PROOF COIL CHAIN.

B	
1/4 in.....	\$10 75
5-16 in.....	10 40
3/8 in.....	10 25
7-16 in.....	10 00
1/2 in.....	9 90
9-16 in.....	9 90
5/8 in.....	9 75
3/4 in.....	9 50
7/8 in.....	9 40
1 inch.....	9 25
Extra for B.B. Chain.....	1 20
Extra for B.B.P. Chain.....	1 40

ELECTRIC WELD COIL CHAIN B.B.

1/4 in.....	\$15 50
3-16 in.....	11 70
1/2 in.....	8 40
5-16 in.....	7 40
3/8 in.....	6 35
7-16 in.....	6 35
1/2 in.....	6 35
5/8 in.....	6 35
3/4 in.....	6 35

Prices per 100 lbs.

FILES AND RASPS.

	Per Cent.
Great Western, American.....	55
Kearney & Foot, Arcade.....	55
J. Barton Smith, Eagle.....	55
McClelland, Globe.....	55
Whitman & Barnes.....	55
Black Diamond.....	45
Delta Files.....	40, 5
Nicholson.....	45
Globe.....	55
Vulcan.....	55
Disston.....	55

COAL AND COKE.

Solvay Foundry Coke.....	\$10 90
Connellsville Foundry Coke.....	8 50
Steam Lump Coal.....	8 50
Best Slack.....	8 05
Net ton f.o.b. Toronto	

BOILER TUBES.

Size.	Seamless	Lap-welded
1 in.	\$30 00	
1 1/4 in.	33 00	
1 1/2 in.	35 00	31 00
1 3/4 in.	34 00	30 00
2 in.	40 00	35 00
2 1/2 in.	38 00	30 00
3 in.	46 00	36 00
3 1/2 in.	52 00	42 00
4 in.	58 00	48 00
4 1/2 in.	62 00	52 00
5 in.	70 00	65 00

Prices per 100 feet. Montreal and Toronto.

OILS AND COMPOUNDS

Castor oil, per lb.	35
Royalite, per gal., bulk	15
Palacine	19
Machine oil, per gal.	26 1/2
Black oil, per gal.	13
Cylinder oil, Capital	45 1/2
Cylinder oil, Acme	36 1/2
Standard cutting compound, per lb.	6 15
Lard oil, per gal.	1 45
Cuon thread cutting oil antiseptic	68
Acme cutting oil, antiseptic	37 1/2
Imperial quenching oil	39 1/2
Petroleum fuel oil	11

BELTING—NO. 1 OAK TANNED.

Extra heavy, single and double	30-5%
Standard	40%
Cut leather lacing, No. 1	1 50
Leather in sides	1 35

TAPES.

Chesterman Metallic, 50 ft.	\$2 00
Lufkin Metallic, 603, 50 ft.	2 00
Admiral Steel Tape, 50 ft.	2 75
Admiral Steel Tape, 100 ft.	4 45
Major Jun. Steel Tape, 50 ft.	3 50
Rival Steel Tape, 50 ft.	2 75
Rival Steel Tape, 100 ft.	4 45
Reliable Jun. Steel Tape, 50 ft.	3 50

WASTE.

White	Cents per lb.
XXX Extra	20
Peerless	20
Grand	19
Superior	19
N L C R	18
Atlas	18
N Empire	18
Ideal	17
X press	16

COLORED.

Lion	14 1/2
Standard	13
No. 1	13
Popular	11 3/4
Keen	10 1/2

WOOL PACKING.

Arrow	25
Axle	20
Anvil	15
Anchor	11

WASHED WIPERS.

Select White	12
Mixed-colored	10
Dark colored	09

This list subject to trade discount for quantity.

RUBBER BELTING.

Standard	40%
Best grades	20%

ANODES.

Nickel	.50 to .54
Cobalt	1.75 to 2.00
Copper	.44 to .46
Tin	.49 to .56
Zinc	.23 to .25

Prices Per Lb.

COPPER SHEETS.

	Montreal	Toronto
Bars, 1 1/2 to 2 in.	55 00	53 00
Plain sheets, 14 oz.		
14x28 in., 14x60 in.	55 00	53 50
Copper sheet, tinned, 14x60, 14 oz.	60 00	54 25
Copper sheet, plain, 14x60 base.	64 00	60 00
Braziers', in sheets, 6x4 base	55 00	52 00

BRASS.

Brass rods, base 1 1/2 in to 1 in rd.	0 55
Brass sheets, 8 in. wide, 20 oz.	0 60
Brass tubing, seamless	0 57
Copper tubing, seamless	0 58

PLATING SUPPLIES.

Polishing wheels, felt.	2 50
Polishing wheels, bull-neck	1 35
Emery in kegs, American	06
Pumice, ground	04
Emery glue	15 to 20
Tripoli composition	04 to 06
Crocus composition	07 to 08
Emery composition	08 to 09
Rouge, silver	35 to 50
Rouge, powder	30 to 35

Prices Per Lb.

LEAD SHEETS.

	Montreal	Toronto
Sheets, 3 lbs. sq. ft.	\$18 00	\$18 00

Sheets, 3 1/2 lbs. sq. ft.	18 00	18 00
Sheets, 4 to 6 lbs. sq. ft.	17 50	17 50
Cut sheets, 1/2c per lb. extra		
Cut sheets to size, 1c per lb extra.		

PLATING CHEMICALS.

Acid, boracic	\$.15
Acid, hydrochloric	.06
Acid, hydrofluoric	.14 1/2
Acid, nitric	.10
Acid, sulphuric	.05
Ammonia, aqua	.08
Ammonium carbonate	.15
Ammonium chloride	.11
Ammonium hydrosulphuret	.40
Ammonium sulphate	.07
Arsenic, white	.12
Copper, carbonate, anhyd.	.35
Copper, sulphate	.17
Cobalt sulphate	.70
Iron perchloride	.20
Lead acetate	.18
Nickel ammonium sulphate	.12
Nickel carbonate	.35
Nickel sulphate	.15
Potassium carbonate	.75
Potassium sulphide (substitute)	.20
Silver chloride (per oz.)	.65
Silver nitrate (per oz.)	.55
Sodium bisulphite	.10
Sodium carbonate crystals	.65
Sodium cyanide, 127-130%	.41
Sodium hydrate	.04
Sodium hyposulphite, per 100 lbs.	5.00
Sodium phosphate	.14
Tin chloride	.60
Zinc chloride	.60
Zinc sulphate	.09

Prices Per Lb. Unless Otherwise Stated.

The General Market Condition and Tendency

THE steady increase in cost of raw materials, particularly iron and steel, continues to be an important factor in the industrial situation. The increase in cost of production is reflected in the price of the finished article which is having a tendency to restrict sales and reduce profits. This unfavorable feature is unavoidable under prevailing conditions, but nevertheless creates an unsatisfactory situation for the manufacturer to contend with. The demand for steel is becoming more insistent and is considerably greater than the capacity of the mills. Deliveries consequently are getting more backward to the despair of the private consumer. Prices of iron and steel continue to climb and a sharp advance on sheets and plates is expected very shortly. The plate situation is very tight and some mills are refusing business. Prices of domestic foundry pig-iron have been withdrawn, owing to the sold-up condition of the furnaces, there being practically no iron available for delivery this year. The scrap metal market is firmer with prices maintained on the basis of last year's schedule. The non-ferrous metal markets are not very active, but prices are firm with the single exception of tin, which has declined. Copper, although quiet, is firm, while the lead market is unusually strong. The demand for machine tools is fairly active, being principally for equipment for general purposes.

Montreal, Que., June 2, 1917.—The curtailment in the manufacture of the heavier shells has enabled the labor situation to be somewhat relieved, but should conscription become an active factor in the mobilization of men for further war effects, the industrial situation will probably be faced with another problem in the maintaining of present activity in many manufacturing lines. Added to this will be the additional men that will be required for the

shipbuilding program anticipated by this and other governments; this latter feature being one of the most essential of all.

Steel

War requirements are now taking precedence over all other industrial activities, and developments in the States are making it almost imperative for private enterprises to withdraw from the market, not only through the high cost of all classes of material, but also

because of the practical inability to obtain it in face of rising conditions. It is anticipated that the steel demands of the American Government will be considerably greater than at first contemplated and producers are looking forward to the necessity of putting additional pressure on the mills to meet the additional requirements. This situation is more pronounced in sheets, and manufacturers of automobiles to a certain degree, are endeavoring to co-operate with the government in the curtailment of production of pleasure cars; this however will be more than balanced by the increased output of heavy motor trucks for use by the United States Government. The American shipbuilding programme has not been definitely settled and the probability is that much more steel tonnage will be placed under construction than at first supposed. Plate mills are working hand in hand with the authorities for the adequate supply of the necessary material and with the increased facilities that are being rushed to completion, the progress of building ships will be advanced as rapidly as possible.

The action of the American government in organizing for war activity has added to the difficulties of obtaining delivery of semi-finished and finished materials, as the authorities are securing preference for the transportation of ores and coal for the production of steel and iron requirements. The heavy demand for billets and sheet bars continues, more particularly for rolling and forging billets, and Pittsburgh quotations have been advanced \$5 per ton, the prices being \$95 and \$115 per ton res-

pectively. Increased demand has been noticed in structural steel, much of this being for enlarging the capacity of steel mills in various sections of the country. The position in plates is of most interest owing to shipbuilding needs, and the early future may develop conditions that will make it increasingly hard for domestic consumers to secure material. The local situation has become more acute with deliveries more backward; dealers have again revised prices, the advance noted this week being \$20 per ton, the current quotations being \$10 for $\frac{1}{4}$ inch to $\frac{1}{2}$ inch plates, \$10.30 for heads, and \$10.10 for 3-16 in. tank plates. The tin plate interests are exceptionally busy and have been so ever since the declaration of war, as the requirements for tin plate to be manufactured into cans is exceedingly heavy. The same condition prevails in the case of sheets of every description for the making of various equipment for army and other needs. Higher prices are the undertone of the market; nominal quotations by local dealers have been revised, these having been somewhat stationary for some time. Black sheets 28 gauge, are now \$10 and No. 10 is quoted \$9.50 per hundred. Apollo brand, 10 $\frac{3}{4}$ oz. is now \$9.75; Queen's Head, \$10.75, the same price applying to Fleur-de-Lis. Colborne Crown No. 28 is quoted at 10 cents per pound. Wire products are in very heavy demand and a stronger market is not unlikely. Heavier business is reported in shafting and deliveries are being extended. The new list price on proof coil chains has been placed into effect by local dealers, the revised prices ranging from \$10.75 for $\frac{1}{4}$ in. to \$9.25 for 1 in.

High Speed Steel

The situation in high speed steel remains comparatively unchanged, although the total volume of business has declined a little owing to the curtailment in the production of the heavier types of shells. The demand for high speed steel however, shows no falling off in proportion to the requirements of the smaller shells and the encouraging increase noted from other sources. The price is well maintained, the quotation ranging around \$2.50 to \$2.90 per lb.

Metals

The general tone of the metal market is one of comparative quiet with a touch of uncertainty owing to the delayed action of the American government. An optimistic feeling seems to prevail however, and all the metals are firm with several showing a stronger tendency. Copper is quiet but quite firm. Tin is inclined to be easier on increased available supply. Spelter is not active but the strength is maintained by the reluctant attitude of the producers. Lead continues strong in spite of decreased demand. Antimony demand is normal with an easier price tendency. Aluminum remains firm and unchanged.

Copper.—The market is still influenced by the uncertain attitude of the government in defining the war policy and the

copper requirements for early future operations. Despite the rumor that were current a week ago, regarding the production costs of copper smelting, the market has retained its strength, but has fallen off in activity and may continue so until more settled conditions offer a basis for future buying. The New York market shows a decline of $\frac{1}{2}$ c on lake and a similar advance on electrolytic, the quotations being 32c and 33c respectively. Dealers here continue to ask 38 $\frac{1}{2}$ c for lake and electro, and 37 $\frac{1}{2}$ c for castings.

Tin.—Considerable arrival of tin has created an easier market and prices have shown a slight decline. A feature of the situation, and one that tends to maintain an unsettled market, is the action of the American government in circulating forms upon which information is to be gathered to enable the committee to secure reliable data regarding the tin available for manufacturing purposes, and also the needs of the trade in connection with future requirements. The American market has developed an easier tendency and prices have declined one cent per pound, the current quotation being 64c. The local market is firm and unchanged at 62 $\frac{1}{2}$ per lb.

Spelter.—The spelter market is in a very unsettled condition and in all probability will remain so until developments indicate the actual trend of affairs. Producers are reluctant to hook future business, and prefer to accept spot or early positions at slight concessions on current quotations. Some producers are thought to have curtailed their output, preferring to await developments upon which to base their future operations. Producers declare that it is unprofitable to smelt the metal at the present prices and under existing conditions. The New York market has fluctuated a little during the week but the present quotation of 95 $\frac{1}{2}$ is the same as last week. Dealers here are asking 13 $\frac{1}{2}$ c on a steady but easier market.

Lead.—The situation in this metal continues to be one of exceptional strength, and while the quotations would appear as being made by the large producers, the actual conditions are to the contrary. The New York quotations both by the Trust and the independent producers, are those at which certain sales can be, and in fact are, made on the open market, and while these large producers realize that this is true, they are nevertheless supplying their regular customers at prices lower than that prevailing in the open market. New York nominal quotations are 10c and 11 $\frac{1}{2}$ c for Trust and outside respectively. The situation locally is very firm on an active market, the price quoted being 13 $\frac{1}{2}$ c per lb.

Antimony.—This metal has taken on an easier tone owing to the recent dullness and prices show a weaker tendency. New York quotations show a decline of 1 $\frac{1}{2}$ c during the week, the present price being 23 $\frac{1}{2}$ c per lb. The local market is quiet and one cent lower, the price asked being 26c per lb.

Machine Tools and Supplies

No important change has taken place in the machine tool situation and conditions are about as usual. The American market is a little unsettled but quite active, and this condition will likely continue until the war policy is finally defined, when additional activity may mark the situation. What might be termed a regular feature of the market is the gradual but certain upward trend to higher price levels, a factor that must naturally follow the general developments of war conditions. Supplies are still in good demand and showing a heavier tendency, with prices inclining upwards.

Scrap

The market in old materials continues very active, the demand for steel and wrought iron scrap being very heavy. A feature of the situation is the apparent scarcity of cars, and all dealers, more particularly in the United States, are requested to see that cars are fully loaded when shipping to facilitate the handling of tonnage with the available equipment. All scraps are very strong, with steel and coppers developing a better undertone.

Toronto, Ont., June 5. — The outlook for manufacturers does not improve in spite of the fact that the volume of trade continues to increase. The shortage of raw materials, particularly iron and steel, is more pronounced and is causing serious inconvenience, as work is being held up. The situation as regards labor is not at all satisfactory. There is a decided scarcity of skilled help and the question of wages seems likely to cause trouble in the near future. The price of coal shows no indication of declining and radical measures will have to be adopted to prevent a serious situation this coming winter.

Steel

The situation in the steel trade is steadily becoming tighter and more complex. Deliveries are so far behind that private consumers are obliged to hold up all kinds of work because of the lack of steel. In this regard conditions are getting more acute owing to the tonnage of steel required for war purposes. Canadian consumers are feeling, more than ever, the effect of conditions in the United States. The American Government will require an enormous volume of steel which will curtail the available tonnage for Canadian consumers. Owing to the pressing demand for steel for munitions and war materials, Canadian mills cannot supply the domestic market. Because of the urgent need for steel rails in Canada, the Imperial Munitions Board has decided to release 25,000 tons of steel which will be manufactured into rails. It is understood that 15,000 tons will be supplied by the Algoma Steel Corporation and 10,000 tons by the Dominion Steel Corporation. With regard to the production of steel, the reports of the Dominion Steel Corporation furnishes some interesting figures. It shows a marked increase in tonnage for the year

ending March, 1917, over the preceding twelve months.

Prices of all steel products are very firm and a number of important advances are expected very shortly affecting black and blue annealed sheets, and plates. It is likely that the next advance will be equivalent to one cent a pound. The plate situation is getting more acute. In view of the American Government's shipbuilding programme, the need of steel plates for this purpose will be very heavy and private consumers will find that deliveries will get worse rather than better. Owing to the rush of orders for plate, some mills are refusing the business. There is no change in the boiler tube situation and prices are holding firm. Wrought pipe is also very firm at unchanged quotations.

A large number of manufacturers of black sheets have withdrawn from the market because of the American Government requirements. The Government orders for sheets so far have been heavy and its requirements will likely be much larger than anticipated. The sheet mills believe that they will be able to take care of their ordinary trade fairly well but there will likely be serious delays in deliveries. Under the circumstances prices are bound to go higher and an advance is expected very shortly on both black and blue annealed sheets.

The steel market in the States is naturally very strong as the Government's requirements for steel are very heavy and will eventually involve an enormous tonnage. The situation as regards deliveries of nearly every form of finished material is tightening as the demand is increasing all the time and is far beyond the capacity of the mills. Prices continue to advance. Tank plates are now 7c. at Pittsburgh. Bessemer and O. H. billets are higher, being now quoted at \$95; O. H. sheet bars are also \$95 Pittsburgh. Wire rods have advanced and are now quoted at \$90 Pittsburgh.

Pig Iron

Prices of domestic foundry pig iron have again been withdrawn as the furnace operating on this grade of iron is booked up for this year. At Buffalo the market is steady yet, although the general trend of prices is upward, no material change has been made from the quotations reported last week. It is understood that the Canada Cement Co. is producing about 50 tons a day of high grade low phosphorus pig iron with the electric furnaces previously used for turning out shell steel.

Scrap

The scrap market is reasonably firm, but there is no very great demand. The buying movement reported a week ago lasted for a few days and then became quieter. Prices are unchanged but are generally firm and, if anything, have a higher tendency.

Machine Tools

There has been a slight revival of munitions activity in the form of light tools for fuse work, the equipment being purchased to increase production. A return to more normal conditions continues to be

the principal feature in the machine tool market. Some nice business has been closed during the week by local machinery houses for equipment for general purposes. Developments in the trade in the States continue to be of a war-like nature and considerable activity is indicated.

Supplies

There have been no price changes of particular importance made during the week, but all quotations are holding firm. Advances were made in gasoline prices in the States in several districts during the past week which may be reflected locally. The crude oil shortage is growing more acute and prices on some grades have advanced.

Metals

Although the metal markets have not been particularly active during the week, prices are firm and have been maintained at last week's levels with the exception of tin, which has declined. The copper market is firm with prices still nominal. Spelter although unchanged has a firmer undertone, while lead continues in a strong position with a higher tendency. Both antimony and aluminum are quiet and situation unchanged. Metals in New York continue to be affected by prospec-

position of lead. The market remains strong owing to the fact that no lead can be had from the leading producers who have consistently remained out of the market for several weeks. There is some hope, however, that increased production during the next month or two will enable the producers to offer lead for sale. Local quotation firm at 14c. per pound.

Antimony.—The market is easier owing to lack of interest on the part of consumers, but quotations are unchanged at 30c. per pound.

Aluminum.—The situation is unchanged and the market remains steady at 68c. per pound.

Pittsburgh, Pa., June 2.—The average price of pig iron in the United States, f.o.b. furnace, on June 1, 1917, was about \$43.75, against an average of \$12 to \$12.25 during the last two months of 1914 and the first six months of 1915. The average price of finished steel products, Pittsburgh, was about 4.59c., Pittsburgh, on the first of this month, against a low point in December, 1914, of about 1.42c. Thus pig iron is selling at nearly four prices and finished steel at more than three prices. Previous rises in 1912, 1909, and 1905-7, carried prices upwards only by from 25 to 40 per cent.

These extremely high prices were not due directly to war demand, but rather to the unsettlement caused by the war. It was not the ordinary case of demand and supply, as after a certain point was reached in the advances, production or supply was not further stimulated. There was no collusion among sellers, the case being simply one of buyers bidding the market upon themselves, actuated by fear that if they did not buy ahead they would be unable to secure material. The advances were made by the buyers rather than by the sellers. The individual seller would have simply placed himself at a disadvantage if he had refused to advance prices when higher prices were so readily obtainable.

Outbreak of War Depressed Prices

The first result of the inception of the war was to depress prices, already at a very low level. Finished steel prices began recovering at the beginning of 1915, while pig iron did not start upwards until July of that year. Until June, 1915, scarcely anyone seemed to realize that the American steel industry could become genuinely prosperous as long as the war lasted, but suddenly, by the end of August, it was realized that the steel mills were filled with orders and were operating practically at capacity. Then forward buying began on a large scale by all classes of consumers. By the end of 1915 steel prices had reached the top level attained in 1907, the highest reached since 1902. Then it was that the run-away began. There was a lull in buying and in price advancing towards the middle of the year, but, in August, advances began again and buying was correspondingly stimulated.

Upon the declaration of German unrestricted submarine destruction on February 1, the common appraisal by leading

CANADIAN GOVERNMENT PURCHASING COMMISSION

The following gentlemen constitute the Commission appointed to make all purchases under the Dominion \$100,000,000 war appropriation:—George F. Galt, Winnipeg; Hormidas Laporte, Montreal; A. E. Kemp, Toronto. Thomas Hilliard is secretary, and the Commission headquarters are at Ottawa.

tive Government buying, which is still somewhat indefinite, and is tending to restrict business and depress the market.

Copper.—Comparatively little interest is being shown in copper at the present time and the market is dull. The position of copper, however, continues strong and prices firm. Present high prices are bringing out small resale lots from consumers, but there is no great amount of copper offered by first hands before August. Local quotations are unchanged and are as follows. Lake and electrolytic 38c., and casting copper 37c. per pound.

Tin.—A decline in the price of tin in London has been followed by declines locally and also in New York. The reason for the decline on this side is said to be due to lack of interest in the market and fairly heavy arrivals of tin recently. Tin has declined 2c. locally and is quoted at 66c. per pound.

Spelter.—The market is dull and unchanged, but the zinc ore situation is strong, which indicates that a decline in spelter is unlikely. The market has a firmer undertone and prices might advance if the demand improved. Local price 12c. per pound.

Lead.—There is no change in the

business men was that war for the United States would result. The pace of price advances became somewhat more rapid, and the pace was continued in April, after the actual declaration of war. During May the advance in steel products gradually tapered off, while the advance in pig iron, if anything, became a trifle more rapid.

The production of pig iron and steel in 1915 was approximately the same as in 1912 and 1913, the two years of heaviest production before the war. Production in 1916 showed an increase of approximately one-third, pig iron rising to 39,400,000 gross tons, steel ingots and castings to 42,800,000 tons, rolled steel to 30,500,000 tons and rolled iron to 1,800,000 tons. Production is now at the rate of more than 40,000,000 tons a year in pig iron, nearly if not quite 45,000,000 tons in steel ingots and castings, and about 32,000,000 tons in rolled steel.

Steel involved in exports, direct and indirect, amounted in 1916 to a trifle less than 8,000,000 tons, or not over about 25 per cent. of the output, so that the strictly domestic consumption of steel was materially greater than in any previous year.

Steel Prices Peak Reached

Evidences have been multiplying in the past two or three weeks that the advance in steel prices has practically come to an end. While somewhat stiffer premiums are ruling here and there on prompt deliveries than was the case two or three weeks ago, there have been no important price advances in the period.

There is a change in the attitude of buyers, who are reflecting that it is quite impossible to determine what will be the actual consumption of steel in the United States six or nine months hence, when the activities of the country will have been turned over completely to the prosecution of war. The rank and file of the people, who have been the consumers of steel in the past two years more than is usually the case, do not yet fully realize what the war means. As to investment buying, that has been relatively light during the war. The monthly reports of the Bridge Builders' and Structural Society have been showing fabricated steel lettings equal to only about two-thirds of the fabricating capacity. The car shops have been operating at only about one-half their capacity. The present attitude of jobbers and manufacturing consumers is that they should go slow in the matter of buying for forward deliveries, and if steel prices remain stationary as they have been lately there will be all the more occasion to follow this policy, as it is traditional that really heavy buying occurs only when prices are advancing.

Steel Prices Largely Nominal

Steel prices are largely nominal as the large mills are sold up very far ahead and to continue to take care of their regular trade they must refrain from quoting in the open market, while the smaller mills, able to make earlier deliveries, are quoting various premiums according to tonnage and delivery. Merchant steel bars for forward delivery are usually quoted at about 3.75c. to 4c. The Steel

Corporation's official price is 3.50c., but even to its own customers it is selling only in a very limited way. Structural shapes are 4c. to 4.25c. What used to be the official price on tank plate is 4.50c., but even the Steel Corporation has sold at above that figure, and early deliveries have been bringing up to 7c., while ship plates to Lloyds' specifications bring 8c. or possibly 9c. for anything like early shipment. Sheets are 7c. to 7.50c. for blue annealed and black for forward delivery, if a seller can be found at all, with premiums for prompt shipment. The official price of the American Steel & Wire Co. on nails is \$3.20, but if this price is named at all it is only to regular customers, and the independents, who advanced to \$3.50 on April 23, are understood to be securing even higher prices than that.

In nearly all cases export prices are quoted higher than domestic and on much export enquiry there are no quotations obtainable at all.

Steel for Government

Practically no information is available as to prices on steel for the Government. Not a great deal of steel has been definitely placed, apart from that required for the 1917 naval program, some 450,000 tons, placed about the close of March, at 2.90c. for the plates and 2.50c. for the shapes and bars. It is not expected that subsequent purchasers will be at as low a level. There is a theory in some quarters that some of the steel manufacturers would prefer to see the whole steel market established at a lower level than the present one, which is not an established level—it simply exists—and that perhaps the fixing of prices for Government steel might tend to bring the market down to a basis which would have some possibility of permanence.

The present program of the Shipping Board is to build as many wooden ships as can be built, perhaps a few hundred instead of the 1,000 about which there has been so much talk in the past three months and so little performance, and steel vessels of about 3,000 000 gross tonnage. For this there would be required about 1,000,000 tons of ship plates and about 300,000 tons of structural shapes. The present output of plates of size suitable for shipbuilding is close to 150,000 tons a month, a considerable part of this being for shipbuilding already under way, which must not be disturbed, and if shipyard capacity can be found or created for the new program there will not be much plate tonnage of this description available for the ordinary consumer. As there is production at the rate of 175,000 or 200 000 tons a month of light plates, narrow plates, etc., some consumers will be able to get along by modifying their plans, building smaller tanks and more of them, and so on.

The sheet requirements of the Government are being formulated and the tonnage is to be distributed among all the mills in proportion to their capacity, at prices well under the current market. The existing scarcity of sheets may not be accentuated as much as was feared recently, as general consumption may decrease. It is reported that some of the

automobile makers have already expressed a desire that their shipments be curtailed.

Pig Iron Continues Advance

While the advance in steel products appears to have come to a halt, nothing of the sort is apparent in the case of pig iron. The theory is that steel making capacity has been increasing right along, while blast furnace capacity has undergone scarcely any increase, and so the blast furnace is to become the "thin neck of the bottle" instead of the steel-making department. If so, there is no occasion for billets to sell at \$90 to \$100 and pig iron at \$40 to \$50. If there is not enough pig iron to keep all the steel-making capacity in operation, the steel works will pay for pig iron the market price of steel, less the cost of conversion, rather than curtail output. Then there is the fact that scrap is scarce, the production of industrial scrap not being heavy, while with the decreased output of shell steel, with its heavy discards, the steel works are not making as much scrap as formerly.

Ten days ago Bessemer pig iron was quotable on the basis of previous sales at \$45 valley furnace for ordinary lots, with small lots \$46 or thereabouts. Without any sales of consequence at intermediate prices there have been sales in the past few days at \$50, one lot of 10,000 tons and another lot of 9,000 tons. Basic, which had been at \$42 valley, for several weeks, suddenly brought \$45 in the case of purchases by one steel mill amounting to 12,000 tons, and sellers now assert no quotations are being made below \$48. Foundry iron is \$43 to \$45 valley, and malleable \$44 to \$45, according to delivery, but the number of sellers is quite restricted.



HYDRO-ELECTRIC BUYS OUT ONTARIO POWER CO.

SIR ADAM BECK announced last week that the Hydro-Electric Power Commission of Ontario has acquired the assets of the Ontario Power Co. for \$22,669,000 on the following terms:—

The company agrees to deliver all its Canadian properties, along with all its physical assets and contracts for the delivery of power, in return for which the commission agrees to pay in its own debentures to the extent of \$8,000,000 for the \$10,000,000 of stock now held by the company, and to assume the bond liability of \$14,669,000 secured by a first mortgage on the property. The company is to receive the current assets and to assume the current liabilities.

The Hydro-Electric Commission will take possession of the property on the first of August. The municipalities will get their power at nine dollars per horsepower, and even selling power at that low figure it is estimated the plant would pay for itself in twenty-five years.

The principal owner of the Ontario Power Company was John Joseph Albright, of Buffalo, N.Y., who agreed to sell to the Hydro-Electric Commission ninety thousand shares of the company's stock at \$80 per share. The shares have a par value of \$100 each, and Mr. Al-

bright has undertaken to accept as payment Hydro-Electric four per cent. forty-year bonds. There is now invested in Hydro property in this province practically seventy million dollars, including money put in by the municipalities.

Estimates made by the Hydro-Electric Commission's technical advisers, headed by Fred Gaby, chief engineer of the commission, show that the estimated revenue per annum from the sale of power is \$2,396,277; the operating expenses, rentals, taxes, etc., will be \$804,718; the fixed charges, interest on bonds, sinking fund, etc., will be \$990,550; the total operating expenses, \$1,795,268, leaving a balance of \$601,009 for the year. From that will have to be deducted interest and sinking fund on the \$8,000,000 worth of Hydro bonds, which will amount to \$400,000, leaving a balance for depreciation of \$201,009.



INSTRUCTIONS TO LAKE MARINERS

UNDER authority of law and of regulations prescribed by the Secretary of War to govern in case of obstructions in St. Mary's River, the following notice and instructions to mariners are issued by Lieut.-Col. Burgess, engineer officer in charge of river improvements:—

The Lighthouse Bureau has marked with two red spar buoys, carrying red lights at night, the channel bank of Pipe Island, opposite and above the wrecks of the steamers Pentecost, Mitchell, and Saxona. The wrecks lie about 1,500 feet south by west of Pipe Island light, with stacks and spars showing above water, and are marked at night by lights maintained by the owners. The available channel between the wrecks and Pipe Island bank, measured at right angles to the sailing line, has a clear width of only about five hundred feet, of which width about four hundred feet is on the easterly side and one hundred feet is on the western side of the chart vessel course. Masters are warned that vessels must not meet or pass each other in the immediate vicinity of the wrecks.

The Coastguard Service has designated the small tug Minto K. as a special patrol vessel to oversee the passage of vessels in accordance with St. Mary's River rules. The patrol tug displays by day a United States coastguard flag and by night a vertical hoist of a red light above a white light. Masters are requested to co-operate with the patrol tug in keeping the channel clear and are notified that failure to comply with signals from that vessel will be punishable by penalty prescribed by law.



COKE FUEL FOR POWER STATIONS

By T. J.

THE Highways Committee of the London County Council has placed an order for eight coke-burning mechanical stokers for use under steam boilers at the Greenwich generating station. The use of mechanical stokers for firing boilers with coke fuel has passed the experimental stage in more than one power station,

but the London County Council will no doubt regard the present installation as more or less experimental so far as they are concerned. It is calculated that the first set of stokers now contemplated will, if worked to their full capacity, consume 100 tons of coke per 24 hours; and having regard to the relatively high cost of coal, as well as the relatively greater degree of efficiency attained in burning coke, every effort will no doubt be made to use the new stokers to their full capacity. The present total coal consumption at the power station has been estimated at 165,000 tons per annum, and according to a figure recently published, the present price is approximately \$8 per ton. Having in mind the huge surplus of coke available in London before the war, the financial advantages which should accrue to the Council by equipping their boilers with stokers which open the door to this alternative source of fuel supply should be considerable.

From a national point of view, the advantages accruing from the policy of using coke in lieu of raw coal to the extent indicated are no less important and far-reaching in their incidence, in view of the abnormal and increasing cost of imported raw materials used in the manufacture of carburetted water gas, a commodity which however desirable and useful in normal times is now regarded as expensive from more than one point of view. Based upon the total yearly consumption which is by no means the largest of any individual power station in London, the valuable residuals which would be recovered by diverting this quantity of coal through the gas works would include 1,650 tons of sulphate of ammonia, 300 tons of high explosive material, and 1,650,000 gallons of coal tar.



SHIP SEIZED IN HARBOR

ACTING on authority of the Superior Court issued by Mr. Justice Allard, in the Practice Division, J. M. Ferguson, K.C., seized the steamship Steelton, in Montreal harbor, belonging to the Matthews Transportation Co., of Toronto, as security in the action taken by a seaman named Charles A. McCarthy against the company for damages under the Workmen's Compensation Act. The plaintiff states that in November last the mate of the ship ordered him to jump from the deck of the vessel and moor it to the St. Gabriel pier. It is alleged that no ladder or other means of descent were provided and plaintiff had to obey the order of his superior officer. In the jump of fifteen feet he was badly injured, and in his action for compensation he charges that the company is responsible for the "inexcusable fault" of their officer. Release of the ship was based on the company giving security which the Court fixed at \$5,000.



METZ

AT the point where the Moselle is joined by the Seille, and makes its way to the Rhine along sundry different arms, stands the ancient city and fortress of

Metz. It is capital of German Lorraine, in Imperial Province of Alsace-Lorraine, 99 miles northwest of Strassburg, and 176 miles due east of Paris. Recent events have rather discredited fortresses; but, says the *Christian Science Monitor*, as fortresses went before the war, Metz was regarded by many, as the strongest fortress in the world. It was always a place of great strategic importance. The Roman, who ever chose his strong places with a judgment which all the countries since have only confirmed, early fastened on Metz, or Mediomatca, as he called it, as one of his outpost cities. He fortified it with care, supplied it with water by means of the mighty aqueduct, the remains of which still exist, and, in the days of the emperors, threw out from it his great military roads to Toul, Langres, Lyons, Strassburg, Verdun, Rheims and Trier.

Under the Romans, Mediomatca flourished, as all great fortresses in those times were wont to flourish; but it was an outpost city, and as the Empire began to weaken, and the legions were withdrawn within an ever-narrowing circle, Metz, like many other great cities and strongholds, was submerged by the barbarian tide. In the Fifth century, Attila the Hun came against it with his hordes, and took it, and the Roman legions knew it no more. Later on it came into the possession of the Franks, and was made the capital of the Frankish Kingdom of Austrasia. Then, after the disruption of the great Frankish realm under the Carolingians, it was included in the Kingdom of Germany. From the beginning of the Thirteenth century it was a free imperial city.

In consequence, Metz grew in importance and prosperity. It was the see of a succession of famous bishops, who ranked amongst the great ecclesiastical princes of the Middle Ages; whilst it was from Metz in 1356, that the Emperor Charles IV. issued his famous Golden Bull, definitely settling the law of the imperial elections. One of the great episodes in the history of Metz is, of course, its heroic defence against the Emperor Charles V. by Francis, Duke of Guise, who held the city for France. Henry II., of France, had captured the city, largely through treachery, in 1552, and almost immediately it became necessary for him to hold it against the forces of the Emperor, Francis, Duke of Guise, the French general, defied all the efforts of the Emperor to regain possession of the city, and Metz thence onwards, until 1870, remained in French hands.

During the years which followed its capture by the French it declined steadily in importance. Its population dwindled from something like 60,000 to about 22,000. It, however, retained its character as a fortress, and, in the latter half of the Seventeenth century, that great fortress builder, Vauban, reconstructed all its works and brought them into line with the needs of the day. For the next 200 years Metz figured but little in French history, and then suddenly within a few weeks of the outbreak of the war, in 1870, as the Germans gradu-

Enlarged Canadian Trade Intelligence Service

Under the arrangement made by the Minister of Trade and Commerce with Sir Edward Grey in July, 1912, the Department of Trade and Commerce, Ottawa, is able to present the following list of the more important British Consulates whose officers have been instructed by the Foreign Office to answer inquiries from and give information to Canadians who wish to consult them in reference to trade matters.

BRAZIL—Bahia, British Consul. Rio de Janeiro, British Consul General.	NETHERLANDS—Amsterdam, British Consul.
CHILE — Valparaiso, British Consul General.	PANAMA—Colon, British Consul. Panama, British Vice-Consul.
COLOMBIA — Bogota, British Consul General.	PERU—Lima, British Vice-Consul.
ECUADOR—Quito, British Consul General. Guayaquil, British Consul.	PORTUGAL—Lisbon, British Consul.
EGYPT — Alexandria, British Consul General.	RUSSIA—Moscow, British Consul General. Petrograd, British Consul, Vladivostok, British Consul. Odessa, British Consul General.
FRANCE—Havre, British Consul General. Marseilles, British Consul General.	SPAIN—Barcelona, British Consul General. Madrid, British Consul.
INDIA—Calcutta, Director General of Commercial Intelligence.	SWEDEN—Stockholm, British Consul.
ITALY—Genoa, British Consul General. Milan, British Consul.	SWITZERLAND—Geneva, British Consul.
MEXICO—Mexico, British Consul General.	URUGUAY—Monte Video, British Vice-Consul.
	VENEZUELA — Caracas, British Vice-Consul.

Canadian Commercial Intelligence Service

The Department of Trade and Commerce invites correspondence from Canadian exporters or importers upon all trade matters. Canadian Trade Commissioners and Commercial Agents should be kept supplied with catalogues, price lists, discount rates, etc., and the names and addresses of trade representatives by Canadian exporters. Catalogues should state whether prices are at factory point, f.o.b. at port of shipment, or, which is preferable, c.i.f. at foreign port.

CANADIAN TRADE COMMISSIONERS.

ARGENTINE REPUBLIC—B. S. Webb, Acting Canadian Trade Commissioner, Reconquista, No. 46, Buenos Aires. Cable address, Canadian.
AUSTRALIA—D. H. Ross, Stock Exchange Building, Melbourne. Cable address, Canadian.
BRITISH WEST INDIES—E. H. S. Flood, Bridgetown, Barbadoes, agent also for the Bermudas and British Guiana. Cable address, Canadian.
CHINA—J. W. Ross, 13 Nanking Road, Shanghai. Cable address, Cancoma.
CUBA—A. T. Quilez, Acting Canadian Trade Commissioner, Lonja del Comercio, Apartado 1290, Havana. Cable address, Cantracom.
FRANCE—Phillipe Roy, Commissioner General, 17 and 19 Boulevard des Capucines, Paris. Cable address, Stadacona.
JAPAN—E. F. Crowe, Acting Canadian Trade Commissioner, P. O. Box 109, Yokohama. Cable address, Canadiao.
HOLLAND—P. H. Geleerd, Acting Canadian Trade Commissioner, Zuiddlaak, 26, Rotterdam. Cable address, Watermill.
RUSSIA—C. F. Just, Canadian Government Commercial Agent, Alexandrinskaja, Plosh 9, Petrograd. L. D. Wilgress, Canadian Government Commercial Agent, Bukhgolza Ulitza No. 4, Omsk, Siberia.
NEWFOUNDLAND—W. B. Nicholson, Bank of Montreal Building, Water Street, St. John's. Cable address, Canadian.
NEW ZEALAND—W. A. Beddoe, Union Buildings, Customs Street, Auckland. Cable address, Canadian.
SOUTH AFRICA—W. J. Egan, Norwich Union Buildings, Cape Town. Cable address, Cantracom.
UNITED KINGDOM—Harrison Watson, Sub-division E.C., 2, 73 Basinghall Street, London, E.C., England. Cable address, Sleighing, London. N. D. Johnston, Sun Building, Clare Street, Bristol. Cable address, Canadian. J. E. Ray, Central House, Birmingham. Cable address, Canadian. J. Forsyth Smith, 31 North John Street, Liverpool. Cable address, Cantracom. F. A. C. Bickerdike, 4 St. Ann's Square, Manchester. Cable address, Cantracom. J. Forsyth Smith, Acting Canadian Trade Commissioner, 87 Union Street, Glasgow, Scotland. Cable address, Cantracom.

CANADIAN COMMERCIAL AGENTS

AUSTRALIA—E. Millin, Royal Exchange Building, Sydney, N.S.W.
BRITISH WEST INDIES—Edgar Tripp, Port of Spain, Trinidad. Cable address, Canadian. R. H. Curry, Nassau, Bahamas.
NORWAY AND DENMARK—C. E. Sontum Grubbegd No. 4, Christiana, Norway. Cable address, Sontums.
SPAIN—J. F. Roberts, Care British Consulate General, Barcelona.

CANADIAN HIGH COMMISSIONER'S OFFICE

UNITED KINGDOM—W. L. Griffith, Secretary, 17 Victoria Street, London, S.W., England. Cable address, Dominion, London.

ally completed their investment of the fortress, and Marshal Bazaine and all his men were shut up within the ring of forts, all the world found itself talking about the place. Metz was invested for fifty-four days. The Prussians simply sat down before it, as they did before Paris, and waited.

On October 14, 1870, Metz capitulated—the first time in all its long history that it had fallen before an attacking force—and Marshal Bazaine and the whole army of the Rhine surrendered to the Prussian commander-in-chief, Prince Frederick Charles. The surrender has never been fully explained. Marshal Bazaine had an effective fighting force of over 100,000 men, and the surrender was so timed that it set the Prussian army free to crush the great effort then being made to relieve Paris. In 1873, after his return from captivity in Prussia, Marshal Bazaine was court martialed for dereliction of duty, and condemned to suffer degradation and the extreme penalty. This latter penalty, however, was commuted to twenty years' seclusion. He was imprisoned in the Ile St. Marguerite, but escaped in 1874 and fled to Spain. Since 1870 Metz has been immensely strengthened, and now it ranks with Strassburg as one of the great bulwarks on the western frontier of Germany.

DOMINION STEEL CORPORATION OUTPUT

THE Dominion Steel Corporation report shows that new records were made in steel products, but that coal production was less than in recent years owing to difficulties of transportation. Steel production for two years compares as follows:

	Mar., 1917	Mar., 1916
Pig iron	346,926	329,664
Steel ingots	377,079	371,086
Bloom and billets for sale, 144,051		142,252
Rails	17,495	35,197
Wire rods for sale	67,492	55,106
Bars	5,259	8,017
*Wire	35,142	36,058
Nails	20,175	19,262

* This includes wire used in manufacture of nails shown in next line.

"The distribution of shipments continues to follow the lines indicated in last year's report," comments the president. "The production of steel for munitions in the form of blanks, barbed wire, etc., has, however, advanced to the first place in importance, and preference is given to this over all other forms of steel. The next element in order of importance is the material furnished to manufacturers in Great Britain, France and Canada, engaged in the production of war materials, for which a strong demand still continues."

The total production of all the collieries was considerably below that of recent years, amounting to 4,279,772 tons, against 5,261,198 in 1916, 4,550,512 in 1915, 5,047,683 in 1914, and 5,051,603 in 1913. "The causes of this falling off," says Mr. Workman, "were beyond the control of your directors, arising for the most part from the scarcity of men consequent upon enlistment for service overseas, and also to a considerable extent from the lack of adequate transportation facilities."

Williams' Stock List

5—14" x 6-0" with taper
 2—14" x 8-0" " "
 2—16" x 6-0" " "
 1—17" x 6-0" Heavy duty
 2—17" x 8-0" " "

Le Blond Lathes

4—19" x 8-0" Heavy duty
 6—19" x 10-0" " "
 2—21" x 8-0" " "
 1—24" x 10-0" " "
 1—25" x 10-0" " "

NEW SHAPERS

2—24" Gould & Eberhardt High duty.
 3—20" Gould & Eberhardt High duty.
 1—24" MILWAUKEE B. G. Crank.
 2—20" KELLY B. G. Crank.
 1—16" KELLY B. G. Crank.
 1—16" SMITH & MILLS Plain.
 2—14" SMITH & MILLS Plain.

NEW GRINDERS

LeBLOND Universal Tool & Cutter.
 STEVENS Universal Tool & Cutter.
 WELLS No. 190 Universal Tool & Cutter.
 WILMARTH & MORMAN No. 1 Surface.
 STENO-DUPLEX with Magnetic Chucks.
 10" x 30" LANDIS No. 1½ Universal.
 10" x 30" LANDIS Plain (used).
 10" x 50" NORTON Plain (used).

NEW SCREW MACHINES

5—No. 6 Warner & Swasey G. F. H.
 2—No. 5 FOSTER G. F. H.
 1—No. 4 WARNER & SWASEY G. F. H.
 1—No. 3 STECHER G. F. H.

MILLING MACHINES

No. 2 FORD-SMITH (new).
 No. 25 BECKER (new).
 No. 22 KEMPSMITH Universal (used).
 No. 2 KEARNEY & TRECKER Universal (used).

The A. R. Williams Machinery Company, Limited

ST. JOHN, N.B.
 WINNIPEG, VANCOUVER

"If It's Machinery, Write Williams"

64 Front Street West
 TORONTO



TAPER THREADS EASILY CUT

With a Geometric Taper Threading Die Head one gets the same rapid production and superior finish that mark all Geometric threads. The chasers follow the taper of the work automatically, and release the work at the end of the cut. Head is withdrawn without touching the finished threads.

Geometric Taper Threading Die Heads are adapted to Screw Machine and Turret Lathe. When not cutting taper threads, the Head can be removed, leaving the machine free for other work. Made to order, specially suited to requirements of machine and work. Employed very generally on fuse work. Give the Geometric finish to your taper threads.

It will cost you nothing to get our quotation on your specifications. May we have them?

THE GEOMETRIC TOOL CO.

NEW HAVEN, CONN., U.S.A.

Canadian Agents: Williams & Wilson, Ltd., Montreal.
 The A. R. Williams Machinery Co., Ltd., Toronto.
 Winnipeg and St. John, N.B.

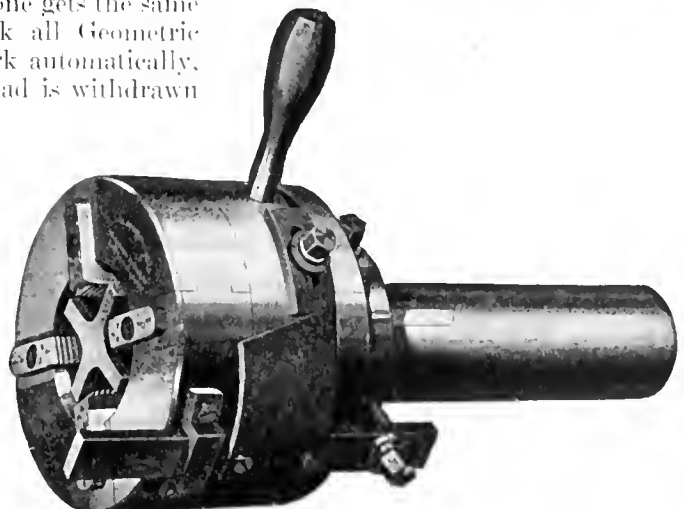

A GEOMETRIC TAPER THREADING DIE HEAD

If any advertisement interests you, tear it out now and place with letters to be answered.

INDUSTRIAL ^A_N^D CONSTRUCTION NEWS

Establishment or Enlargement of Factories, Mills, Power Plants, Etc.; Construction of Railways, Bridges, Etc.; Municipal Undertakings; Mining News

ENGINEERING

Bracebridge, Ont.—The Muskoka Foundry Co., contemplate making an extension to their plant.

New Westminster, B.C.—A builder permit has been issued to the Westminster Mill Co., for the construction of a frame boiler house, 40 by 60, at an estimated cost of \$1,000.

Brantford, Ont.—The Brantford Computing Scale Co., have purchased a site to the rear of their factory. It is understood that extensive additions will be made, including a foundry.

Port Coquitlam, B.C.—A. F. Bernstein of Vancouver, is negotiating with the City Council over a proposition to establish a smelter and steel works here. It is understood that the plant would cost \$500,000.

St. Catharines, Ont.—The St. Catharines Brass Co. are going to enlarge their plant at a cost of \$15,000 and will be exempt from taxes for ten years. This firm will manufacture plumbers supplies and brass fittings.

Peterborough, Ont.—A big transformer built for the Ontario Hydro-Electric Commission burst into flames about four o'clock Sunday morning in the transformer test department of the Canadian General Electric Co., and was seriously damaged by fire and water. E. G. Patterson, general superintendent of the plant, estimated the loss at \$10,000.

Winnipeg, Man.—The steel of the old Louise Bridge, weighing some 20,000 tons, and now housed in the city yards is to be sold by tender together with all the scrap and other old metal that can be scraped up by the various civic departments. Controller Cockburn told the Board that present opportunities of disposing of old metal would never be more favorable.

ELECTRICAL

Kingston.—The civic utilities commission was notified by the Hydro Electric Commission that hydro will be connected with this city by August 15.

Petrolia, Ont.—The Town Council has passed a by-law authorizing the issuing of 20-year debentures to the amount of \$15,000, to enable the Petrolia Hydro-Electric Commission to make extensions of the power line to various industries and pumping outfits that are asking for power.

Hamilton, Ont.—Manager Sifton, of the Hamilton Hydro Commission, has recommended to the Hydro-Electric Board that a \$12,000 electric plant be installed upon the premises of the Dominion Steel Foundry. He said that company was now demanding 600 or 700 additional

horse-power, and that the installation of a sub-station at that plant would defer the construction of the contemplated sub-station on Trolley Street about two years. The latter would cost \$35,000, he declared. The board will consider the proposition.

MUNICIPAL

Tilbury, Ont.—The Town Council contemplate installing a pumping plant. Engineer, J. J. Newman, Windsor, Ont.

Montreal, Que.—P. E. Mercier, city engineer, and Controller C. Cote, favor installing a garbage destructor plant to cost \$1,000,000.

St. Thomas, Ont.—The St. Thomas Packing Co. will have to vacate their property to make way for a sewage disposal plant.

St. Mary's, Ont.—The Town Council will likely expend \$1,500 for the purchase of a small motor-driven pump for the pumping plant.

Hamilton, Ont.—The Provincial Board of Health has granted the city's application in regard to waterworks extensions. An expenditure of \$127,000 on new pumps at the Beach station is now authorized without reference to the ratepayers.

Toronto, Ont.—The York Township Council passed a by-law authorizing the Clerk to take preliminary proceedings for the construction of a 6-inch water main to supply residents at Baby Point present between Langmuir avenue and Talbot Place.

Belleville, Ont.—By-laws to equalize the assessment of all local manufacturing establishments and to purchase Victoria Park for \$5,000 were carried by the ratepayers. The first named had a majority of 35 over the required two-thirds, and the park by-law had a majority of 277.

St. Johns, Nfld.—The Newfoundland Shipbuilding Co., whose agent Messrs. Amonsens & Strong, have been here selecting a site the past month will likely decide on Harbor Grace as the most suitable locally for their operations. The principal in the undertaking is Christopher Hannevig, of Christiania Norway, whose headquarters are at New York.

Victoria, B. C.—The Coughlan Shipyards of Vancouver have just laid the keel of the second of the fleet of six steel steamers being built by them for the Imperial Government. This vessel will be launched in December and will be ready for delivery early in the new year.

Peterborough, Ont.—The bridges by-law passed by a large majority on May 31. The purpose of the by-law is to enable the Council to construct a high-level bridge over the River Otonabee for vehicular, foot and street railway traffic

on Hunter Street, at the estimated cost of \$260,000, and also to construct a bridge for vehicular and foot traffic at London Street across the River Otonabee at an estimated cost of \$20,000. The bridges by-law was an important factor in the re-establishment in Peterboro of the Quaker Oats plant, which was destroyed by fire in December last. The company has already commenced the erection of a new plant, the cost of which will exceed \$1,000,000.

GENERAL

Goderich, Ont.—The North American Chemical Co., propose building an addition to their factory to cost about \$25,000.

St. Catharines, Ont.—The St. Catharines Silk Mills contemplate building a factory at the corner of Page and Queen Streets. The cost is estimated at \$60,000.

Quebec, Que.—Fire on June, 1, destroyed the plants of the Frazerville Chair Co., at Frazerville, county of Temiscouata. The loss is estimated at \$30,000, partly covered by insurance.

St. Catharines, Ont.—The Bonner-Heddle Co., who have a factory at Paris, Ont., propose to build within six months on their property back of Vine street. The building is to cost not less than \$30,000. This firm will handle and treat foreign and domestic wool or known as carbonizing wool process.

Gravenhurst, Ont.—The Canadian Potash Corporation have about closed negotiations with the Gravenhurst Stone Crushing Co., to lease their large plant and immediately commence the manufacture of potash. It is stated that considerable percentage of potash exists in the Felspar veins in Muskoka granite and a large deposit is available right at the mill.

CONTRACTS

Hamilton, Ont.—The Canadian General Electric Co.'s tender of \$1,420 for switch-board extensions has been accepted by the Hamilton Hydro-Electric Commission.

Toronto, Ont.—The John V. Gray Construction Co., Toronto, have been awarded a contract for the erection of a box storage building for the Swift Canadian Co., on St. Clair Ave., Toronto.

Toronto, Ont.—At a meeting of the York Township Council, the Ritchie Construction Co. were awarded the contract for the construction of a concrete road bridge on Finch avenue, at \$4,562. The contract for the construction of a culvert on Eglinton avenue, east of Fairbank, was awarded to A. Johnston, for \$900.

ILLINOIS *Special* CUTTERS

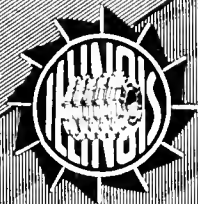
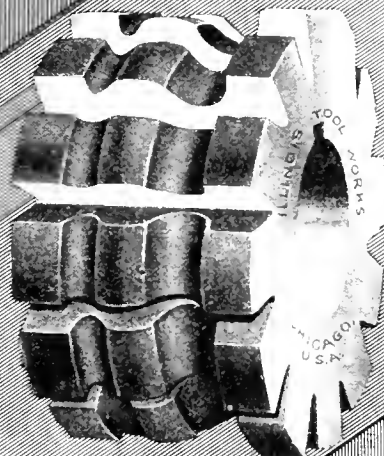
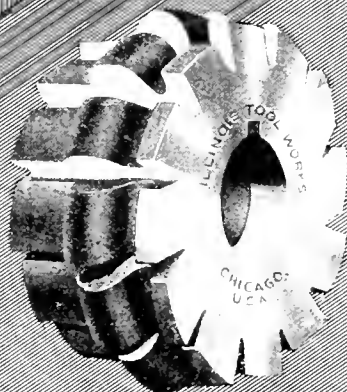
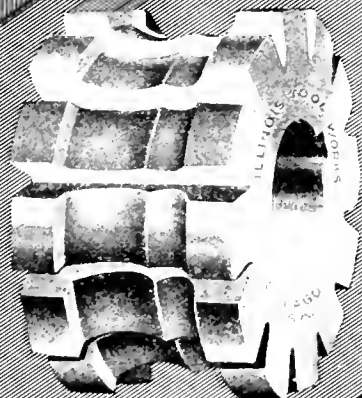

IT has been our privilege to assist many of the largest manufacturers in the country in solving intricate milling problems by supplying Cutters specially designed to meet their individual requirements. This service is under the direction of experienced engineers who design all special tools and supervise their manufacture from the selection of the high speed steel to the final testing of the finished product.

If you are confronted with difficult milling or hobbing problems, it will pay you to get in touch with us.

ILLINOIS TOOL WORKS, CHICAGO, U.S.A.

Canadian Representative: **ALLAN B. WEARING**, Canadian Pacific R.R. Bldg., Toronto, Ontario

If any advertisement interests you, tear it out now and place with letters to be answered.

PATENT ATTORNEYS

BABCOCK & SONS

ESTAB. 1877.

PATENTS-TRADE MARK-DESIGNS
IN ALL COUNTRIES

Book "Patent Protection"—free. Master of Patent Laws, Formerly Patent Office Examiner.

99 St. James St., - Montreal, Que.
Branches: Ottawa, Washington.

RESEARCH BUREAU

REPORTS BY EXPERTS ON SCIENTIFIC, TECHNICAL AND INDUSTRIAL DEVELOPMENT.

SPECIAL RESEARCHES ARRANGED.

PATENTS, TRADE MARKS, ETC.

HANBURY A. BUDDEN CABLE ADDRESS
712 DRUMMOND BLDG., MONTREAL "BREVET"

PATENTS

Fetherstonhaugh & Co.,
Patent Solicitors, Head Office,
Royal Bank Bldg., Toronto,
Ottawa Office, 5 Elgin St.
Send for our Plain Practical
Pointers. Copy of National
Progress, in which our patents
are advertised, mailed free.

PATENTS PROMPTLY SECURED

In all countries. Ask for our Investor's Adviser,
which will be sent free.

MARION & MARION 364 University St.

Merchants Bank Building, corner
St. Catherine St., MONTREAL, Phone Up. 6474
and Washington, D.C., U.S.A.

MacKINNON, HOLMES & Co.

Limited
Sherbrooke Quebec

Engineers, Manu-
facturers and
Erectors of Steel
Structures]

We Specialize in
Bridges, Buildings,
Towers, Tanks, Pen-
stocks, Roof Trusses,
Columns, S m o k e
Flues and Stacks,
Coal Bins, Ore Bins,
Buckets, R e f u s e
Burners, Stills, Air
Receivers, etc.

WRITE FOR
PRICES.

Brantford, Ont.—A contract has been let to the General Supply Co., for three Electro-Bleaching-Gas. Co. liquid chlorinators.

TENDERS

Swift Current, Sask.—Tenders will be received until June 19, by the City of Swift Current, for one Mo'or-Driven Centrifugal Pump having a capacity of 800 Imperial gallons per minute against a 300 ft. head. Geo. D. Arnott, City Clerk.

Trail, B.C.—Tenders will be received up to June 13, for work in connection with the extension of the waterworks system. Plans and specifications may be seen at office of W. E. B. Monypenny, city clerk, or at office of A. L. McCulloch, consulting engineer, Nelson, B.C.

Stratford, Ont.—Tenders will be received up to June 11, for furnishing and constructing a radial brick or concrete chimney and foundation for the refuse incinerating plant on St. Patrick Street, Stratford. Specifications and forms of tender may be obtained from the office of the city engineer, A. B. Manson.

PERSONAL

George Bury, vice-president of the C. P. R. is on his way to the west on his annual inspection trip.

L. C. Fritch, who has been general manager of the Canadian Northern Railway, for four years, and who came to the road from the Chicago and Great Western Railway has been appointed general manager of the Seaboard Air Line.

Sir William D. Reid, president of the Reid-Newfoundland Railway, and J. K. L. Ross, a director of the C.P.R., have been elected directors of Dominion Steel Corporation to fill vacancies caused by the death of the Hon. Robert Mackay and Hon. David Mackeen.

B. M. W. Hanson, vice-president and works manager of the Pratt & Whitney Co., Hartford, Conn., and Dundas, Ont., has been appointed chairman of a sub-committee of the general munitions board on machine guns by the council of national defense in Washington.

H. R. Charlton Honored.—The International Jury of the Panama-Pacific Exposition announces that an award of a gold medal and diploma has been made to H. R. Charlton, General Advertising Agent of the Grand Trunk Railway System, for his work as collaborator. The Grand Trunk Pavilion and exhibit at San Francisco were among the features of the big fair.

Sir Joseph Wesley Flavelle, Bart., Chairman of the Imperial Munitions Board, has been included in the King's birthday honors, having been created a Baronet in recognition of his services to the State in the above capacity. Sir Joseph is president of the William Davies Co. and the National Trust Co. He was born near Peterborough in 1858, and his home is in Toronto.

David E. Park, one of the most prominent steel manufacturers in the Unit-

ed States, died at Pittsburg, Pa., on May 30, at the age of 68 years. Mr. Park was one of the organizers of the Crucible Steel Company and formed the Park Steel Company, a \$10,000,000 concern, which was later taken over by the Crucible Company. He also built Pittsburg's first "skyscraper."

A. G. Norris, transmission expert, with the S K F Ball Bearing Co., Hartford, Conn., will spend about three months in Canada on behalf of this concern and in co-operation with the Canadian Fairbanks-Morse Co., who are the sole agents for Canada for the S K F transmissions. Mr. Norris will work on transmissions only and divide his time between the Montreal and Toronto-territories.

James Pender, for the past twenty-five years managing director of James Pender & Co., St. John, N.B., nail and wire manufacturers, died on May 30. The late James Pender had a long connection with the trade, having commenced his business career fifty-one years ago as a clerk with T. McAvity & Sons, hardware merchants of St. John. He subsequently commenced the manufacture of horseshoe nails on his own account and later took W. O. Purdy into partnership under the present firm name. The manufacture of wire nails was added, and Mr. Pender was made managing director of the firm. He was a member of the St. John Board of Trade, and was recognized as one of the most prominent manufacturers in the district.

James Spelman, president of the John S. Metcalf Co., grain elevator engineers and builders of Montreal, London, Chicago and Melbourne, died at his home, on Cote St. Antoine Road, Westmount, Que., on May 27. He was born at Ottawa, Ont., December 10, 1860, was educated in the Ottawa Schools and was graduated from the Royal Military College, Kingston. He was employed for some time on C.P.R. construction work in the West and later went into grain elevator building, being associated with the Metcalf Company for twenty years. He was president for the past five years. He was a member of the Engineers' Club, the Canadian Society of Civil Engineers and the Western Society of Engineers.

INCORPORATIONS

Rein Drive Tractors, Ltd., has been incorporated at Ottawa with a capital of \$5,000,000 to acquire as a going concern Canadian Rein Drive, Ltd., Toronto, Etc. The incorporators are Harry M. Tandy, J. W. F. Kerr and W. A. MacFarlane all of Toronto.

Kinleith Paper Mills, Ltd., has been incorporated at Ottawa with a capital of \$400,000 to manufacture paper and pulp at St. Catherine's, Ont. The incorporators are William Bain, Robert Gowans and T. H. Simmonds all of Toronto.

Kilcon Knitting Mills of Canada, Ltd., has been incorporated at Ottawa with a capital of \$50,000 to manufacture hosiery and knit goods of all kinds at

Three Rivers, Que. The incorporators are J. W. Blair, F. T. Laverty and C. A. Hale all of Montreal.

Guelph Carpet & Worsted Spinning Mill, Ltd., has been incorporated at Ottawa with a capital of \$40,000 to manufacture rugs and carpets, etc., at Guelph, Ont. The incorporators are Robert Dodds, Roland Dodds and George McPherson all of Guelph, Ont.

The Liquid Carbonic Co., has been incorporated at Ottawa with a capital of \$10,000 to manufacture and deal in chemicals and gases of all kinds. The head office is at Toronto and the incorporators are W. A. J. Case, J. B. Taylor and W. M. Smith all of Toronto.

MARINE

Less New York Shipping.—Twenty-one ships less in April arrived at the port of New York in May. There were 428 arrivals with a total tonnage of 1,099,433, as compared with 449 ships with a total tonnage of 1,149,740 for the month of April.

Forty-five more ships sailed from New York, however, during May, with a total tonnage of 1,155,508, as compared with 383 vessels of 1,043,466 tons for the previous month.

American vessels arriving during May number 127, six more than April, while 134 American ships left port, as against 107 vessels of American registry during April.

The principal departures for May, besides American were: British, 136; French, 11; Scandinavian, 77, and Dutch, 24, as compared with British, 140; Dutch, 17; French, 9, and Scandinavian, 71, for April.

Among the ships of all other nationalities which arrived here last month were: British, 144; French, 12; Scandinavian, 94; and Dutch, 12; as compared with British, 141; French, 12; Dutch, 24, and Scandinavian, 104, for the month of April.

Victoria, B.C.—Despite rumors to the contrary, Mr. Butcher and Capt. Troup representing the Imperial Munitions Board, have placed no orders for wooden ships. They are conducting an investigation as to the possibility of developing the industry on the Coast.

New Westminster, B. C.—J. C. Shields and Capt. Robinson, ex-mayor of Kamloops, who are at the head of the Pacific Shipbuilding Co., a concern recently organized to build wooden steamers on the Fraser River, are making arrangements for the location of their plant on the south side of the river just above the bridge.

Halifax, N.S.—Mr. McGillivray, president shipbuilding commission, addressing the Board of Trade recently, stated that representatives of large steel shipbuilding interests had recently visited the city and were to return with some definite proposition and the city should be prepared to state what it was willing to do to assist in the establishment of a large enterprise.

New Lakes Vessel Puts to Sea.—Under

ECONOMY No. 40 HEAVY DUTY, the EFFICIENT SHELL SAW

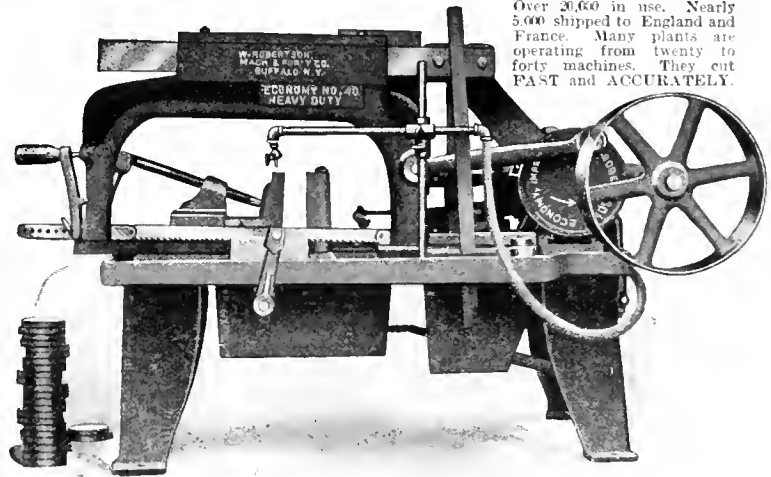

Over 20,000 in use. Nearly 5,000 shipped to England and France. Many plants are operating from twenty to forty machines. They cut FAST and ACCURATELY.

Draw Cut—Oil Compression Lift, relieving the blade on the return stroke. Frame cannot fall and break blades. Quick Acting Vise—Cut Gears—Friction Drive—Automatic Stop. Capacity 8 x 8". Takes blades from 10 to 17". This tool will give greater production at less cost than any tool in your plant. Economy Saws are built in sizes up to 8 x 18". PROMPT DELIVERIES.

W. Robertson Machine & Foundry Company, Buffalo, N.Y., U.S.A.

MORTON MANUFACTURING CO.
 PORTABLE PLANERS
 DRAW CUT SHAPERS
 SPECIAL DRAW CUT R SHAPERS
 FINISHED MACHINE KEYS
 STATIONARY & PORTABLE KEY WAY CUTTERS
 SPECIAL LOCOMOTIVE CYLINDER PLANERS
 OFFICE AND WORKS: MUSKEGON HEIGHTS U.S.A.



Tool Room Surface Grinder

Easily Adjusted, Strong, Accurate, Fast.

Has rigid grinding surface and large oil and water jet controls. Perfectly adjustable table and surface grinder. Tell us your machinery wants expert on special details. Satisfaction assured.

J. E. WING & SON, HAMILTON CANADA

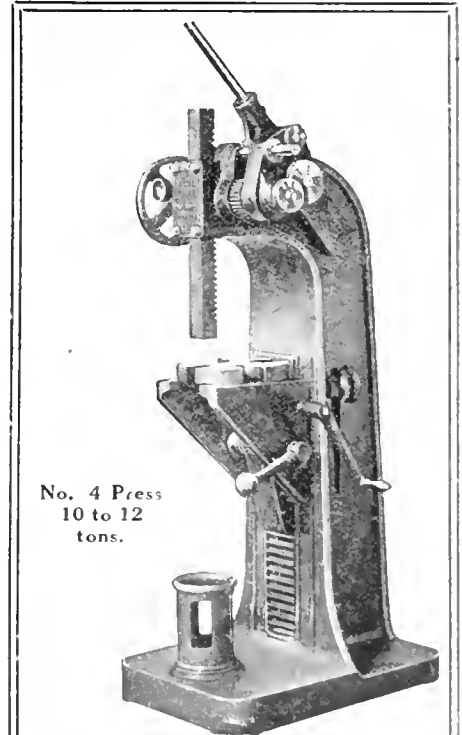

No. 4 Press 10 to 12 tons.

Write for complete information on Atlas Arbor Presses. All sizes for all purposes.

ATLAS PRESS CO.
 330 N Park St.
 Kalamazoo, Mich., U.S.A.

Cameron Babbitt Retainer

(Patented in Canada and the U.S.A.)

Not like clay or other material, as it does not stick to the work or hands. Does away with using leather or paste-board at end of box.

The only satisfactory compound for retaining molten metal and can be used over and over again for months—no deterioration.

For any metal.

For prices and samples apply to

A.S.K. Chemical Company, Elora, Ontario

"Barnes-Made" SPRINGS

are unusual in service and wear

They are the result of sixty years' experience, unsurpassed equipment and highly skilled workmanship.

A trial will convince you that "Barnes-Made" Springs are the best buy.

Established 1857.

THE WALLACE BARNES COMPANY
218 South St., Bristol, Ct., U.S.A.

Makers of "Barnes-made" Products
Springs, Screw Machine Products, Cold Rolled Steel and Wire

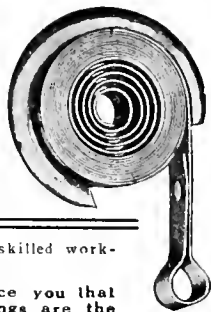

"HAWK" D CHROME VANADIUM STEEL



Will
Give You
Exceptional

Shell Forging Production

WITHOUT AN EQUAL FOR BOTH FIRST AND SECOND OPERATION PUNCHES.

Comes to you heat-treated and ready for use.

It does not stick to the work.

There are many cases where each punch has turned out over 2,000 shells.

It means more shells, per machine per day.

STEEL OF EVERY DESCRIPTION.

Hawkrige Brothers Company

303 Congress St., BOSTON, MASS.
U. S. A.

command of Captain Perry, of Cherbourg, France, and manned by a crew of Frenchmen and Chilians, the steamer Toulouse, just completed at the Superior Shipbuilding Co.'s yards, cleared from Duluth, Minn., on June 3, for the Atlantic, where she will be used in coasting and in the North Sea trade. The boat is 254 feet long, 48 feet beam and 24 feet deep and is built along ocean lines, with deckhouse amidships. The Orleans Railway of France is her owner.

Will Omit Canadian Calls.—The White Stare Line, according to the local agent at Port Huron, Mich., has decided to omit all landings at Canadian ports hereafter, and will confine the trips of its boats to the American side. This action has been brought about by the recent announcement that the Government will in future enforce the ruling of the Department of Commerce and Labor that all passenger steamers carrying freight instal a sprinkling system for fire protection.

Big Shipping Profits.—The report of the Oceanic Navigation Co., White Star, for last year, shows a profit of £2,402,758 after providing for excess profits taxation. The profit represents an increase of £434,473 over 1915, which is more than double that of 1914. Dividends of £750,000, equivalent to 20 per cent., have been paid, leaving a balance of £300,636 to be carried forward, compared with £156,768 in 1915. Dividends of 35 and 30 per cent. were paid in the previous year. Last August the capital of the company was increased by £750,000; £375,000 of the White Star consists of 33 vessels and the capital of the company is owned by the International Mercantile Marine.

Reid Wrecking Co. Sold.—The business of the Reid Wrecking Co., with its fleet of tugs and wrecking apparatus, has been sold to the Reid Towing & Wrecking Co., a corporation headed by Roy Wolvin, of Duluth, according to a statement given out on June 1, by Captain J. T. Reid. Mr. Reid and his brother, Wm. H. Reid, are associated with the new company. It is expected that J. T. Reid will be manager. The Reid drydock at Port Huron is not included in the transaction, but will continue under the present management. The tugs transferred are the S. M. Fischer, James Reid, Sarnia City, Smith, Diver and Manistique. It is probable that the Port Huron and Sarnia offices will be continued as at present.

Tusket, N.S.—The Tusket Shipbuilding Co., Tusket, N.S., expect to lay the keel of their first ship some time in July, as the moulds are being made and the company's timberman is now at work acquiring timber. It is intended to build 4-masters of about 500 or 600 tons, with auxiliary engine space. The vessels will be standardized as far as possible to facilitate and expedite construction. Robie McLeod of Liverpool, N.S., who has built some 70 wood sailing craft during the past 30 years will be master shipbuilder. It is proposed to have two shifts at work in the period from dawn to dusk, in which case from 30 to 40 hands will be employed. All communications relating to the enterprise should meantime be addressed to Louis N. Fuller, 163 Hollis Street, Halifax, N.S.

Steam Barge Burned.—The steam barge Sand King, owned by W. Fraser, of Montreal, and in charge of H. F. Cumming, of Cornwall, was badly damaged in the St. Regis river near the Indian village of St. Regis, on the morning of June 1, by a fire which broke out near the boiler room. The Sand King was anchored in the river the night previous, preparatory to commencing loading operations the following morning. On the boat, besides Mr. Cumming, were Louis Hence, of Summertown, the mate, and Frank Garvin, of Farran's Point, engineer. The cabin and sleeping quarters, cooking utensils, shovels, and everything about the deck, were completely destroyed. The boat was beached in five feet of water, which saved the greater part of the hull. The loss is partially covered by insurance. Mr. Hence had his hands badly burned and Mr. Cumming also had one hand slightly burned.

TRADE GOSSIP

The Canadian Fairbanks-Morse Co., Montreal, have subscribed \$3,000 towards the Y.M.C.A. Overseas Fund.

Big Locomotive Order.—It is reported in New York financial circles that Russia has placed an order with American manufacturers for 500 locomotives to cost approximately \$25,000,000, and 10,000 cars at \$15,000,000. Contracts have not yet been signed, but all preliminary arrangements, it is understood, have been completed. This is said to be the largest single order for railroad equipment received in this country.

Customs Revenue for May.—The Dominion customs revenue for May amounted to \$17,144,368, the largest monthly return in the history of the country. The revenue increased by \$4,089,987, as compared with the corresponding month last year. For the two months of the fiscal year which have now elapsed the total customs revenue was \$31,293,525, as compared with \$23,400,953 for the corresponding period during the past fiscal year.

Smoking Prohibited Where Explosives Are.—An Order-in-Council has been passed at Ottawa prohibiting persons employed on docks, vessels, vehicles or in stores where ammunition, explosives or inflammable substance required for the manufacture of explosives are stored from smoking or having any smoking materials in their possession while in the vicinity of such places. Persons in a state of intoxication are forbidden to enter the places mentioned. A fine of \$5,000 or imprisonment for five years, or both, may be imposed for contravention of the order.

Copper Output Expands.—The four leading porphyry copper companies, Utah, Ray Consolidated and Chino, produced 38,230,302 pounds of the metal in April, an increase of 1,645,267 pounds over March. The natural deduction to be made from these figures is that improved weather conditions marked the April operations, while labor was probably in better supply. Utah's output increased 1,718,836 pounds over March and 2,674,230 pounds over April, 1916. Chino beat its March total by 168,023 pounds and

surpassed April last year by 1,872,604 pounds. The others fell behind March slightly, but Ray Consolidated topped the total of April, 1916, by 608,491 pounds. Together the companies exceeded the production of the preceding April by 5,166,616 pounds.

The Canada Cement Co., is understood to be turning out at Longue Pointe, Que., about 50 tons a day of high-grade low phosphorous iron, which is selling to-day at a phenomenal price, about \$70 to \$75 a ton. With the shell orders nearly completed the management decided some time ago to make use of the electric process and take some advantage of the existing great scarcity of pig iron.

New Type of Tractor to Haul Guns.—A Washington, D.C., despatch states that a new type of tractor combining power, speed and ability to turn within its own length, has been developed by army engineers for hauling guns of medium calibre. It is believed the tractor will result in the elimination of artillery horses almost entirely. "The new creeping or self track laying type of small or medium size developed by the American army," says the announcement, "is built without steering arrangement in front, and while possessing relatively as much power as the type now used in France, is capable of turning within its own length by simply reversing or stopping one of the creeper drivers while the other side continues to move." Eventually, it is believed, horses will be used only for the lightest artillery required to move rapidly over bad ground.

Montreal and Lachine Ry. Anniversary.—Wednesday, May 30th was the 60th Anniversary of the Montreal and Lachine Railway Co., opened in 1847, and which the Grand Trunk, when that newly formed company came on the scene, in 1852, took over, as it took over other small pieces of road, in those far-off pioneer days. It was the first railway in the country, on this side of the St. Lawrence; but there was in 1836 a bit of line called the Champlain and St. Lawrence Railway and which operated more or less erratically between Laprairie on the South Shore and St. Johns—a line whose ultimate objective, between rail and boat, was Kingston, via Prescott. In the building of the Montreal and Lachine Railway, an engine disappeared in the "bog" as the district traversed might be called and was never heard of afterwards. The anniversary has an interest for railway people, and for others, too, for that was the beginning of railway life and activity in the country—new and undeveloped, and which was opened up by the Grand Trunk which now serves the most populous portions of the Dominion in Quebec and Ontario.

Will Roll Steel Rails.—Owing to the urgent need of the Canadian railroads for steel rails, it is announced that the Imperial Munitions Board has decided to release 25,000 tons of steel which will be manufactured into rails at the Soo plant and so cover immediate needs in this connection. It is understood that 15,000 tons will be supplied by the Al-

Subscriptions Invited From Friends Abroad

Canadian Machinery and Manufacturing News is published weekly. Representing, as it does, the industrial life and activities of Canada, it should prove of very considerable value to those who wish to buy Canadian products, and to those who may wish to sell in Canada.

As a technical journal it compares very favorably, we think, with any other high class publication, and will be found to be well worth the subscription price, and more.

If you are favorably impressed with this number, we think you will find other issues equally interesting. *Canadian Machinery* contains from one hundred and twelve to one hundred and seventy-eight pages—fifty-two issues in the year. We invite subscriptions from our friends abroad, and attach a coupon for the sake of convenience.

Subscription Order Form

To the Publishers,
CANADIAN MACHINERY,
143 University Ave.,
Toronto, Canada.

Gentlemen,—

You may enter our subscription to CANADIAN MACHINERY for one year, and until ordered discontinued, to be sent to address below. We enclose money order covering same.

Yours truly,

Name

Full address

City County.....

The subscription price to Great Britain and her colonies is 12s. 6d. United States, \$3.50, other countries 16/- per year.

"PURO - FY"

(MADE IN CANADA)

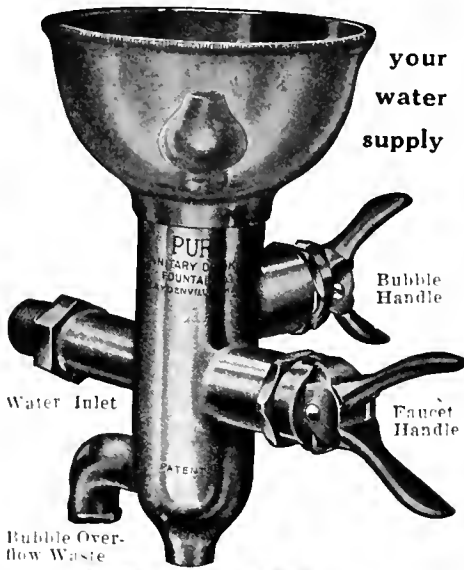

goma Steel Corporation, to the C.P.R., G.T.R. and T. & N. O. railways, while the Dominion Steel Corporation will supply their portion 10,000 tons, to the Intercolonial Railway. The former company will be occupied on the manufacture of these rails for about two weeks, and the latter company about ten days. These concerns are practically the only two Canadian companies which have rail plants ready for use, although for some long time past these works have been making shell steel for the Munitions Board. Following the completion of the above orders, it is stated that the plants will be turned back to the munitions business.

Steel for Shipbuilding.—In the United States steel trade the time is believed not far distant when the public will realize that tremendous sources are being centred on the output of material for ships. The Sparrow's Point plant of the Bethlehem organization is understood to be concentrating on ship steel to the exclusion of much structural goods. Its own shipyard will absorb a great deal of the supplies fabricated on the spot, but it is probable that other yards will draw upon the product of the mills, too. Three million tons of shipping included in the Shipping Board's plan will require approximately 1,000,000 tons of plates, shapes, etc. In view of the fact that the country's capacity for rolling and fabricating steel is in the neighborhood of 35,000,000 tons per year, the Government program would require no more than five or six weeks for the steel to be produced if all factors were co-ordinated on the task. This is from the theoretical point of view. The full capacity of the plants naturally could not be completely centred upon the task, for the steel trade as a whole would be badly disorganized. But steel makers, it is known, are speeding up the output of Government ship material, and deliveries are looked for as rapidly as the ship-builders can handle the steel.

The policy as outlined by Messrs. Butchert and Troup was heartily approved by the meeting and a committee consisting of Messrs. G. Giles, Vancouver Engineering Works; H. Schaake of the Schaake Company and W. T. Fraser of the Vancouver Machinery Depot with Mr. Bushby as an ex-officio member, was appointed to co-operate with the representatives of the board and to assist them in procuring the machinery and equipment required for the vessels.

Will Fight Pine Blister Disease.—The white pine of Canada is valued roughly at \$200,000,000. At the recent annual meetings of the Commission of Conservation, Canadian Forestry Association, Canadian Society of Forest Engineers and Canadian Lumbermen's Association, urgent resolutions were adopted favoring the appropriation by the Dominion Government of \$50,000, to provide for supplementing the work which will be done by the Provinces of Ontario and Quebec in locating and eradicating the pine blister disease, and for making a general survey of the situation throughout Canada. Scouting is necessary in New Brunswick and Nova Scotia to determine whether the disease has yet become established in those Provinces; and attention must also be given the forests of western white pine in southern British Columbia.

THE American Museum of Safety conferred a Gold Medal Award upon the Puro Sanitary Drinking Fountain at the First International Exposition of Safety and Sanitation. The Puro Sanitary Drinking Fountain won because it deserved to win—Puro had merits that made it stand head and shoulders above any other drinking apparatus.

Safe SANITARY Quickly Attached
Simple Economical

These are the qualities that forced the leading safety and sanitary engineers to pick Puro in preference to all others. No device can be as efficient that does not contain all these qualifications; and Puro was not tried for first place; Puro was first. Don't be satisfied with half-way goodness, or makeshift drinking arrangements for your employees. If the men in your factory must drink, give them a clean drink. Puro is clean—it does not rust or corrode. Puro is economical. It allows just the proper amount of cool, clean, fresh water to come through the bubbler. No spurring, no overflowing, no loss. Puro regulates itself. You can attach it in five minutes. Tell us how many men in your factory and your water pressure in pounds—We'll tell you just what it will cost to "PUROFY" YOUR WATER SUPPLY.

PURO SANITARY DRINKING FOUNTAIN

TRADE MARK
147 University Ave. TORONTO, ONT.

CATALOGUES

Vaughan Flow Meter.—A bulletin issued by the Spray Engineering Co., Boston, Mass., illustrating and describing the Vaughan flow meter which is a simple and efficient instrument for indicating the flow of liquids in pipes.

Shop Furniture.—The New Britain Machine Co., New Britain, Conn., have issued a binder contract containing a number of bulletins and price list dealing with an interesting line of steel shop furniture. The product consists principally of shop stools, racks, bench legs, portable work stands, vise stands, tote boxes, etc. Each type is illustrated and fully described, together with specifications giving the principal dimensions, etc. Other lines illustrated and described include buffing and polishing machines, lathe racks and machine guards, etc. The binder is substantial and of attractive appearance.

Progress in Water Works Pumps is the title of a catalogue issued by the De Laval Steam Turbine Co., Trenton, N.S., and compiled from the company's records. The catalogue contains a great deal of interesting information relative to development and advantages of steam turbine driven centrifugal pumps for city water supply covering the chief requirements for such installations and the suitability of these pumps for this class of work. An interesting feature of the catalogue consists of a number of brief descriptions of important municipal installations in Canada and the United States, together with half-tones showing the layout of each plant. Copies of this

B.C. to Supply Machinery for Wooden Ships.—At the meeting of the B. C. Metal Trades Association held recently in the offices of the association in the Pacific Building for the purpose of meeting Messrs. Butchert and Troup, who are representing the Munitions Board in connection with the placing of orders for wooden steamers, Capt Troup explained the proposed programme of the board and what machinery and equipment would be installed in the vessels. G. G. Bushby, manager of B. C. Marine, Limited, and Knox Walkem, president of the Vancouver Machinery Depot, addressed the two representatives of the Munitions Board and pointed out to them that the association represented 95 per cent. of the engineering and machinery plants of British Columbia and that the present plants could build the engines and machinery required for the vessels and if the necessary raw materials could be provided, the boilers also. Mr. Butchert stated that all orders for machinery and engineering work would be placed locally, provided the work could be handled.

THE IRON WORKS

LIMITED

(Successors to)
Owen Sound Iron Works

Owen Sound, Ont.

Engineers

Boiler-makers

Founders

Machinists

Tank Work
Smoke Stacks,
Grey Iron and
Brass Castings,
Special
Machinery
Made to
Order

catalogue may be obtained on application from the Turbine Equipment Co., Toronto, Ontario.

Commercial Gear Cutting.—This is the fifth edition, revised and enlarged, of a treatise on commercial gear cutting and dealing more particularly with the commercial production of spur, helical and internal gears. The booklet has been compiled and issued by the Fellows Gear Shaper Co. of Springfield, Vt. The book deals almost exclusively with the gear shaper method of cutting gears, although for the sake of comparison brief reference is made to the formed cutter process and hobbing process. The book contains ten chapters dealing with various phases of the subject and includes principally descriptions covering the method of operating a gear shaper cutter, generating a cutter and the generated cutter at work. There are also full descriptions of the No. 5 "Fellows" gear shaper, the No. 65 helical gear shaper and other different sizes of gear shapers. The concluding chapter deals with the application of the gear shaper to other work than gears and shows a number of examples of work cut on the gear shaper. The information in this chapter will be of value to manufacturers in general. This is an interesting publication containing considerable information of value for cutting gears. There are 64 excellent illustrations, while the catalog contains 94 pages and is gotten up in an attractive manner.

BOOK REVIEW

The Embrittling Action of Sodium Hydroxide on Soft Steel.—In certain districts where feed water for boilers contains sodium hydroxide many boiler troubles have appeared which have given no little concern to boiler users and makers. Such water is found in the central Eastern part of Illinois, in the Fox River valley in the northern part of the same state, and in portions of other states. The Engineering Experiment Station of the University of Illinois has just completed an investigation of this source of boiler distress, and the results are published in bulletin 94 by S. W. Parr. It was noted that boilers using feed water containing sodium hydroxide often developed fine cracks radiating from rivet holes or extending from hole to hole. The experiments showed that the effect upon the metal is to cause brittleness which makes it less capable of withstanding steam pressure and temperature changes. Among the remedies suggested is the addition of a salt having properties which cause it to react with the alkali and yield a harmless product. Copies of bulletin No. 94 may be obtained gratis by addressing C. R. Richards, Director, Urbana, Ill.

Brought Her Husband.—In Saskatchewan recently, there was a political convention at which women were delegates for the first time, and on one of the hotel registers there appeared the registration, "Mrs. Alfred Smith and husband."



Steel Shell Forgings or Billets of any size or weight will move any distance or about curves upon our specially constructed Gravity Carriers and Incline or Horizontal power devices. No labor required.

Canadian Mathews Gravity Carrier Co., Toronto, Ont.

**TRY HAMILTON
BABBITTS**
We Make Nothing Else
GEO. E. JOBBORN, Hamilton, Ont.

OVENS
Enameling and Varnishing Ovens heated by Gas, Electricity, Steam or Coal. Write for Booklet.
Brantford Oven & Rack Co., Ltd.
Brantford, Canada.

A PRICE PYROMETER makes it certain
Get a Record of Working Temperatures
Uncertainty is a time and effort waster—to be sure at a glance means efficiency. There is no "doubt," when you have a Price Pyrometer.
See that there is a Price Indicating Instrument within sight of every furnace in your heat-treating department. And have a Price Recording Pyrometer in your office to get a record of working temperature.

Let us send you our catalogue and full particulars — How you can make it certain.

METAL STAMPINGS

We are manufacturers of stamped parts for other manufacturers.

We do any kind of sheet metal stamping that you require. Our improved presses and plating plant enable us to produce the finest quality of work in a surprisingly short time

We can finish steel stamping in Nickel, Brass or Copper.

Send us a sample order.

W. H. BANFIELD & SONS
372 Pape Avenue, Toronto, Can.

THE PRICE ELECTRIC CO.
12368 Euclid Avenue, CLEVELAND, OHIO

CLASSIFIED ADVERTISING

Rates (payable in advance): Two cents per word first insertion; one cent per word subsequent insertions. Count five words when box number is required. Each figure counts as one word. Minimum order \$1.00. Display rates on application.

SECTION

FOR SALE

FOR SALE—1 HOLDEN-MORGAN BASE milling machine, 3-inch shell. Manitoba Bridge & Iron Works, Winnipeg.

FOR SALE—ONE LEWIS TYPE ENGINE built by Waterous Engine Works, 240 H.P., flywheel 73" x 18", automatic governor, a bargain. One steam pump, 4½" x 2¾" x 4". Write Box 217, Moncton, N.B. c24m

ONE—50 K.W., 220 VOLT, D.C. PEERLESS Self-oiling, Automatic Engine, with Switch-board complete. Two, 10 H.P., D.C., 220 volts motor; one 20 H.P., D.C., 220 volts motor; one feed-water heater and purifier 36" x 12".—The American Motor Sales, Chatham, Ont. c24m

TWO NEW BOILERS, 66" x 16", FOR SALE, immediate shipment. One smoke stack, 54" x 80", also one C.G.E. generator, 62.5 K.V.A. with exciter and switchboard. Box 312, Canadian Machinery. (c24m)

ONE LATHE 16" x 4½" BACK-GEARED—Built by P. P. Silk Machine & Tool Co., Cincinnati, Ohio. One lathe 18" x 3', back-geared. Built by the Bradford Mill Co., Cincinnati, Ohio. Four Murchey collapsible dies, Capacity 1½" to 2½". Box 272, Canadian Machinery. ctmf

FOR SALE—STEEL WATER TOWER WITH-out tank, 94 feet high. Will support tank holding 13,000 gallons. Cost new \$1,600.00. Will sell for \$400.00 f.o.b. cars. Northern Aluminum Company, Limited, Shawinigan Falls, P.Q. c22m

FOR SALE 132 PIECES VITRIFIED SEWER pipe, 15 of which have small pieces chipped off flange. Size 36 inches diameter, 30 inches long, 2¾-inch wall. Make us an offer. Northern Aluminum Company, Limited, Shawinigan Falls, P.Q. c22m

FOR SALE—TWO 16x6 REED PRENTICE Automatic Lathes. One Bertram Cap Lathe, 48 x 10, Four No. 10 Heavy Duty Baker Drills. One No. 2D Colburne Drill. One Heavy Duty Reliance Machine Co. Turret Lathe for inside boring of 6" shells.—Canadian Blower & Forge Co., Kitchener, Ont. c24m

I—ROBB HORIZONTAL STEAM ENGINE, 10 x 12, 35 h.p. Just overhauled by makers. Price \$300.00. 1—Heavy Duty Rockford Drill, Suitable for shells or heavy work. Weight of drill 3,600 lbs. Good as new. Write for specification. 1—Jones & Lamson 2 x 24 Turret Lathe, 2¼" hole in spindle, 16" swing, cone drive, collet chucks for bars up to 2" diameter. Or lathe can be fitted with standard universal chuck. Flat turret 16" diameter. Good condition. Price \$400.00. 1—Warner & Swasey Turret Lathe. Round turret, diameter 8", hand cross feed for turret. Swing 14". Fairly good condition. Price \$200.00. 1—Bertram 2-spindle Thread Miller. Made by makers for threading 18-pdr. shells. Now used for threading sockets. Good condition. Steel Furnishing Co., Ltd., New Glasgow, Nova Scotia. c2m

FOR SALE

THE NATIONAL MANUFACTURING COM-pany, Limited, Ottawa, have the following machine tools for sale:—1 25-ft. Westinghouse Air Compressor, with Receiver; 1 20" Drill Press; 1 4-spindle 12" Drill Press, Cincinnati Pulley & Machine Co.; 1 Canadian Blower & Forge Co., 21" Drill Press; 2 Racine Power Hack Saws; 1 McKechnie Bertram Planer, 36" x 36" x 10' 0" bed; 1 Wagner Motor, 10 H.P., 2-Phase, 60 Cycles, 440 Volts, 1140 R.P.M., complete with starting base; 1 Barnes 21" Drill Press; 5 Simplex Lathes, never used; 2 Ford-Smith Grinders, suitable for 18-pdr. Shrapnel Shell; 2 Thread Millers for 18-pdr. Shrapnel, in need of repairs; 3 Shrapnel Furnaces; 1 Turret Lathe. c23m

SPECIAL MACHINERY

MANUFACTURERS—WE CAN UNDERTAKE work to any specification—munition production equipment or otherwise. Write W. H. Sumbling Machinery Co., 7 St. Mary St., Toronto.

S. VESSOT & CO., GENERAL MACHINE SHOP and Grey Iron Foundry. We can undertake at present time light machining and grey iron castings, at reasonable prices. Address Joliette, Que. c1m

AGENCIES WANTED

AGENTS HAVING CONNECTION WITH large workshops factories in mechanical construction business and dealing in tools and tool outputs, wish to represent in France a good house manufacturing especially Lathes, Drills, Files, Vises, Tinware, Machinery, Tool Outputs, etc. Good references. Address Hoon & Barronnet, 11 Rue Bichet, Paris. c24m

BUSINESS CHANCES

FOR SALE—MACHINE SHOP AND FOUNDRY—good business location; good manufacturing district for general repairs. Near two railroads and Welland canal for transportation. Cheap electric power. Owner desires to retire. For further information write Box 314, Canadian Machinery. c22m

FOR SALE—A MEDIUM-SIZED TWO-STORY brick factory situated in the best small city in Ontario. Buildings in good condition, suitable for either metal or wood-working; shipping facilities unexcelled. Two trunk lines; direct connections east, west, north and south. Educational advantages the very best. Plant will be sold at a bargain and on easy terms of payment, if desired. Apply Box 294, Canadian Machinery. c2m

SITUATIONS WANTED

HIGH-GRADE MAN, EXPERIENCED IN GEN-eral construction, manufacturing, machine shop work and heavy shells, is open for a good offer only. Box 315, Canadian Machinery. c25m

STEEL FOUNDRY EXECUTIVE, CANADIAN, with fifteen years' experience with most up-to-date plants in United States, seeks similar position in Canada. Thoroughly conversant with sales, operation and business management. Box 306, Canadian Machinery. c22m

PRACTICAL WORKS MANAGER AND ME-chanical expert with years of experience in United States and Canada, a specialist in munition work, open for engagement. Best of references. Apply Box 304, Canadian Machinery. c4m

ELECTRICAL ENGINEER—COLLEGE GRADU-ate, five years' practical experience; now employed in large industrial plant, electric-driven; responsible position desired; money not sole object; recommendations. Box 305, Canadian Machinery. c26m

SITUATIONS VACANT

WANTED—TOOL MAKERS TO WORK ON munitions. Apply at once, Wallaceburg Brass & Iron Mfg. Co., Ltd., Wallaceburg, Ontario. c25m

MECHANICAL ENGINEER WANTED—FIRST-class opportunity for the right party. Must be energetic, ambitious, sober and have some knowledge of French. Apply Box 286, Canadian Machinery. ctmf

WANTED—SALESMEN TO SELL BABBITT metals on commission as side line. Good commission. Give full particulars as to firms represented and territory covered. Box 303, Canadian Machinery. c21m

WANTED—EXPERIENCED MECHANICAL draftsman, one who has had some experience on machine design and factory layout preferred. Apply, stating experience and salary desired, to the Goodyear Tire & Rubber Company of Canada, Ltd., Bowmanville, Ont. c23m

6" SHELL FOREMAN WANTED WITH SPE-cial qualifications to get production from shop at Peterborough, Ont., which has been running on 6" shell for eighteen months. Tooling and shop inspection separately organized. Foreman to give his whole attention to obtaining maximum production. Give full particulars in first application as to previous experience, references, and salary required, otherwise application will not be considered. Apply to Box 316, Canadian Machinery. c25m

One Advertiser Said To Us—

"One insertion of this ad will do"—when sending in copy for a condensed ad. This firm sends in from three to four ads a month, so they ought to know.

While two or three insertions give your proposition more chance to be considered, still this incident shows just what advertisers know this section will do for them. Use its service now—every time you need it.

Canadian Machinery

Classified Advertising Section

143 University Ave., Toronto, Ont.

CANADIAN MACHINERY AND MANUFACTURING NEWS

A weekly newspaper devoted to the machinery and manufacturing interests.

Vol. XVII.

TORONTO, JUNE 14, 1917

No. 24

EDITORIAL CONTENTS

Manufacturing Aspect of Machine Shop Organization	615-617
General	617
Zeebrugge.	
Editorial Correspondence	618-620
Appearances Good and Bad...A Kink in Refitting Lathe Boxes...Paste for Oil Light Joints...Babbitt Metal Gibs...Handy Chart for Solving Fabric Belts in Plies...Babbitt Wisdom...Rasp for Soft Metal...Factors Governing Cost of Power.	
"Spokes" in Industry's Wheel	621-622
A. F. White.	
General	622-623
Machine Shop Lighting...Canadian Manufacturers' Association Annual...Order- ing Commutator Brushes.	
The "Alquist" Transmission Gearing for Ship Propulsion	624-627
Contemporary War Articles	628-632
British Machine Gun Factory...Recovery of a Wrecked Submarine...Origin of Tonnage Measurement Systems...Canada's Trade Statistics...Brush Holders for Slip Rings.	
Progress in New Equipment	633-634
Universal Angle Plate...High Speed Ball Bearing Sensitive Drill...Thread Mill- ing Fixture for Shells...Electric Grinding Motor.	
Editorial	635
Present Influences on Machine Tool Activity...More Publicity Concerning Our Shipbuilding Effort.	
Selected Market Quotations	636-637
The General Market Conditions and Tendencies	637-640
Summary...Montreal Letter...Toronto Letter...Sydney Letter...Pittsburgh Letter.	
Industrial and Construction News	62-67

THE MACLEAN PUBLISHING COMPANY, LIMITED

JOHN BAYNE MACLEAN, Pres. H. T. HUNTER, Vice-pres. H. V. TYRRELL, Gen. Man.

Publishers of Hardware and Metal, The Financial Post, MacLean's Magazine, Farmer's Magazine,
Canadian Grocer, Dry Goods Review, Men's Wear Review, Printer and Publisher, Bookseller and
Stationer, Canadian Machinery and Manufacturing News, The Power House, The Sanitary Engineer,
Canadian Foundryman, Marine Marine Engineering of Canada.

Cable Address: Macpubco, Toronto; Atabek, London, Eng.

ESTABLISHED 1887

CANADIAN MACHINERY AND MANUFACTURING NEWS

PETER BAIN, M.E., Editor. B. G. NEWTON, Manager.
Associate Editors: A. G. WEBSTER, J. M. WILSON, J. H. RODGERS.

CHIEF OFFICES:

CANADA Montreal, Southam Building, 128 Bleury Street, Telephone 1004; Toronto, 113-153 University Ave.
Telephone Main 7324; Winnipeg, 22 Royal Bank Building, Telephone Garry 2313.

GREAT BRITAIN LONDON, The MacLean Company of Great Britain, Limited, 88 Fleet Street E.C., E. J. Doll,
Director. Telephone Central 12960. Cable Address: Atabek, London, England.

UNITED STATES New York, R. R. Huestis, Room 620, 111 Broadway, N.Y., Telephone Rector 8971; Boston, C. L.
Morton, Room 733, Old South Building, Telephone Main 1294; A. H. Byrne, 1104-5-6-7 Fort Dearborn Bldg.,
105 W. Monroe St., Chicago, Telephone Randolph 3234.

SUBSCRIPTION PRICE Canada, Great Britain, South Africa and the West Indies, \$3.00 a year, United States,
\$3.50 a year, other countries, \$4.00 a year. Single Copies, 15 cents. Invariably in advance.

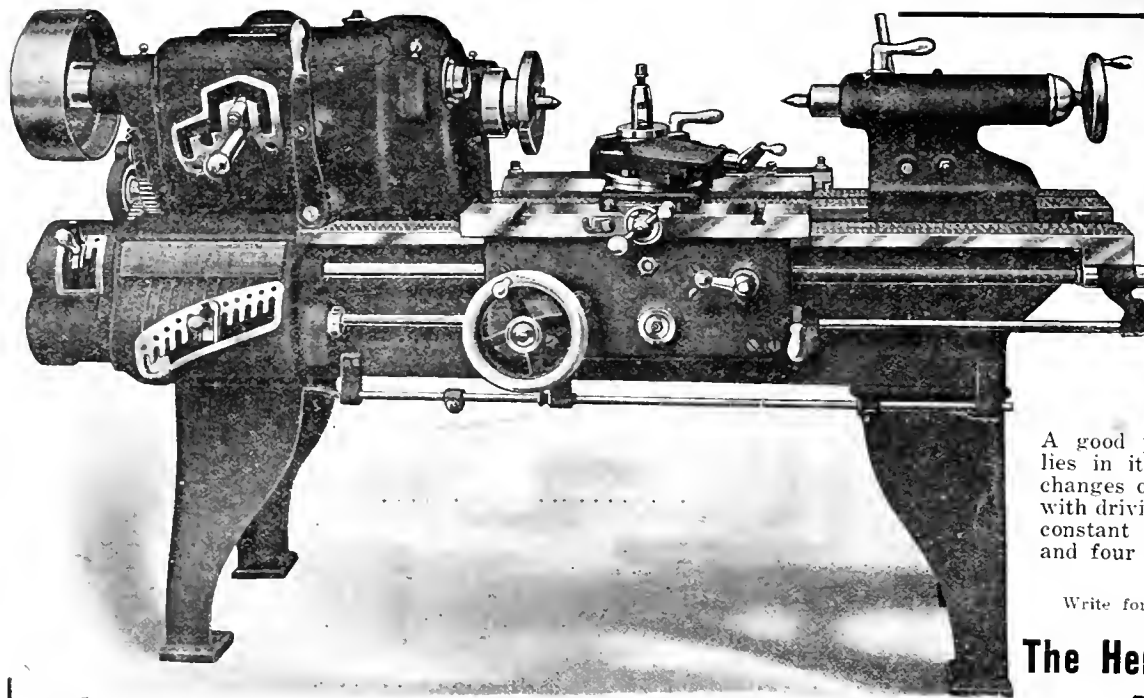

Henhey 18-inch Geared Head Lathe

A good point in this lathe lies in its eight mechanical changes of speed for spindle with driving shaft running at constant speed—four direct and four through back.

Write for descriptive circular.

The Henhey Machine Company Torrington, Conn.

Canadian Agents: A. R. Williams Machinery Co., Toronto, Ont.; A. R. Williams Machinery Co., 260 Princess St., Winnipeg; A. R. Williams Machinery Co., Vancouver; A. R. Williams Machinery Co., St. John, N.B.; Williams & Wilson, Montreal.

SPEED, ACCURACY, ADAPTABILITY

Thirty-six different threads and feeds are had through mounted change gearing, each change being quickly made through controlling handles in gear boxes.

Lathe has automatic stop for stopping carriage in either direction when feeding or screw-cutting—invaluable for internal work to shoulders and for duplicating pieces.

INDEX TO ADVERTISERS

A		D		L		S	
Adams, Ogden R.	94	Davis Bourneville Co.	91	L'Air Liquide Society	27	Rockwell Co., W. S.	92
Aikenhead Hardware Co.	63	Davis, W. F., Machine Tool Co.	75	Lauris Machine Co.	90	Robinson Machine & Tool Co.	15
Armstrong Bros. Tool Co.	91	DeLoro Smelting & Refining Co.	11	Lathro Electric Steel Co.	12	Roper & Co., C. F.	82
Armstrong, Whitworth of Canada	5	De Mooy Mach. Co.	11	London Bolt & Hinge Co.	67	T	
A. S. K. Chemical Co.	77	Dominion Iron & Working Co.	24	Lynd-Fargular Co.	68	Sebastian Latho Co.	92
Atkins, Wm., & Co., Ltd.	11	Dominion Machinery Co.	29	M		Sheltons, Ltd.	92
Aurora Tool Works	13	Dunay Co., H. A.	12	MacNab Machy, Co., The John.	20	Shuster Co., F. B.	90
B		E		Magnolia Metal Co.	94	Shore Instrument & Mfg. Co.	91
Balcock & Sons	63	Eastern Machine Sewing Equip.	57	Manufacturers' Equipment Co.	86	Silver Mfg. Co.	92
Baird Machine Co.	94	Elmes, Chas. F.	22	Marsh & Henthorn, Ltd.	50	Skimmer Mach. Co.	70
Bainfield, E. J.	14	Eric Fanny Co.	22	Matthews, Jas. H., & Co., Inc.	33	Skinner Chuck Co.	91
Bainfield, W. H., & Sons	66	F		McAvity & Sons, T.	70	Sleeper & Hartley, Inc.	82
Barnes, W. F., & John.	13	Fethorstonburgh & Co.	65	McCabe, J. J.	18	Smart-Turner Mach. Co., Ltd.	93
Barnes, Wallace, Co.	69	Fitzevald, W. H. J.	72	McClay-Branit Machy, Co.	73	Smith Mfg. Co., Philip	78
Bath, Cyril J.	72	Foss & Hill Machy, Co.	81	McDongall Co., R.	75	Standard Alloys Co.	9
Beatty & Sons, M.	73	G		McLaren, J. C., Belting Co.	93	Starr's Co., L. S.	3
Beatty & Co., Inc.	81	Galt Mach. Sewing Co.	77	Mechanical Engineering Co.	105	Steel Co. of Canada	3
Bennett, W. P.	94	Gardner Machine Co.	93	Metal Mfg. Service	76	Stephens, John, Co.	107
Bertram, John, & Sons Co., Ltd.	1	Gardner-Walker Machy, Co.	75	Metalwood Mfg. Co.	25	Stocker-Rumley-Wachs Co.	75
Front cover and page	1	Garym Machine Co.	74	Monarch Brass Mfg. Co.	77	Stow Mfg. Co.	93
Bertram's, Limited	97	Geometric Tool Co.	64	Montreal Machy, & Supplies	99	Strong, Kennard & Nutt Co.	92
Bilton Machine Tool Co.	15	Gilb Instrument Co.	67	Morton Mfg. Co.	153	Swedish Steel & Importing Co.	7
Bliss, E. W.	23	Gilbert & Backer Mfg. Co.	103	Match & Menyweather Machy, Co.	71	Swedish Gage Co., Inc.	79
Bramford Owen & Bask Co.	67	Gooley & Edlund, Inc.	25	Munchley Machine & Tool Co.	88	N	
Bridgford Mach. Tool Works	3	Grant Gear Works, Inc.	92	Napier Saw Works	92	National Machine Tool Co.	93
Bridford Company	91	Grant Mfg. & Machine Co.	1	New York Machinery Exchange	74	Nicholson File Co.	81
Brownell Machy, Co.	60	Greenfield Machine Co.	61	Noble & Westbrook Mfg. Co.	91	Niles-Bement-Pond, Inc.	91
Brown's Copper & Brass Rolling Mills	85	H		Northern Crane Works	92	Northern Crane Works	91
Brown & Sharpe Mfg. Co.	97	Hamilton Gear & Machine Co.	82	Norton, A. O.	92	Norton Co.	93
Buden, Hansbury A.	65	Hamilton Machin. Tool Works	19	Nova Scotia Steel & Coal Co.	10	O	
Burfield & Co.	89	Hanna & Co., M. A.	40	Oven Equipment & Mfg. Co.	107	P	
C		Hankins Bros.	67	Oshorn (Canada), Ltd., Sam'l.	14	Q	
Canada Machinery Corporation	108	Henley Machine Co.	112	R		W	
Canada Metal Co., Ltd.	25	Hendman, John T.	17	Parmer & Bulloch Co.	92	Valeau Crucible Steel Co.	12
Canada Wire & Iron Goods Co.	15	Hunt Mach. Co.	16	Parry, Wm. R.	23	Walcott Latho Co.	16
Can. B. K. Mason Co.	21	Homer & Wilson	77	Patric, H. W., Ltd.	69	Walton Co.	47
Can. Bond Hardware & Coaline Co.	81	Best Metal Co.	91	Patric of Montreal, Ltd., H. W.	69	Wells Bros. Co. of Canada	82
Can. Blower & Pump Co.	11	Hunter Saw Machine Co.	65	Port Hope File Mfg. Co.	69	West The Setter Co.	102
Can. Fairbanks-Morse Co.	23	Hunterford Brass & Copper Co.	84	Positive Clutch & Pulley Works	91	Wilkinson & Compass	94
Can. Bridge Co., Ltd.	83	Houlton Rogers Machinery Co.	82	Patt & Whitney, Inside front cover	31	Whitcomb-Blasich Mach. & Tool Co.	21
Can. Desmond Stephen Mfg. Co.	73	Hyde Engineering Works	36	Patric, R. E., Ltd.	31	Whiting Foundry Equipment Co.	24
Can. Drayon Steel Co.	91	I		Pape Sanitary Drinking Fountain Co.	67	Williams, A. R., Machinery Co.	61
Can. Economic Lubricants Co.	81	Heal Tool & Mfg. Co.	88	S		Williams, J. H., & Co.	98
Can. Inspection & Testing Laboratories, Ltd.	91	Independent Pneumatic Tool Co.	31	Steeple, John, Co.	107	Willson & Co., T. A.	92
Can. Metal Foundries, Ltd.	77	Iron Works, The	66	Standard Alloys Co.	9	Williams Tool Co.	91
Can. Steel Foundries, Ltd.	77	J		Winnipeg Mach. & Tool Works	29	Willmarth & Morgan Co.	89
Can. S. K. F. Co., Ltd.	72	Jacobs Mfg. Co.	87	Winnipeg Gear & Engineering Co.	76	Z	
Carlyle Johnson Mach. Co.	81	Janline Co., A. B.	74	Zenith Coal & Steel Products Co.	91	R	
Chapman Double Ball Bearing Co.	81	Jencks Mach. Co.	70	F		R	
Cincinnati Pulley Machy, Co.	90	Johnson, Geo. E.	67	Radco Tool & Machine Co.	27	Richmond Mfg. Co.	87
Consolidated Press Co.	119	Johnson Mach. Co., Carlyle	87	Richmond Machy, Depot	69	Rivett Latho & Grinder Co.	110
Cook, Asa S.	92	Joyer Co., Geo. A.	92	Front cover and	110	Rockford Drilling Mach. Co.	97
Corbet Foundry & Mach. Co.	17	K		F		R	
Coulter Machy, Co., C. W.	72	Kearney & Clark, Ltd.	10	Rockwell Co., W. S.	92	R	
Curtis & Curtis Co.	36	Keeler & Co.	10	Robinson Machine & Tool Co.	15	R	
Cushman Chuck Co.	97	Keeler & Co.	10	Roper & Co., C. F.	82	R	

afternoon, and an occasional Sunday for a time, looking into every corner and cubby-hole. The number of points that can be brought out in a survey of this kind will surprise one who has never tried it. All this is a mere matter of getting acquainted with the job, and it goes without saying that if this point is neglected all future work will rest on an insecure foundation.

The location of the headquarters of the new works manager should be open to all shop employees and the men encouraged to come in. It should, therefore, be in the place most accessible to the works, and it should also be perfectly plain in its appointments. The business to be transacted with the shop can be carried on over common oak desks and bare floors with a far better feeling than it can over mahogany furniture and Oriental rugs. The average workman does not care to come with his greasy shoes, soiled clothes and dirty face into an elegantly appointed office to talk about the things the manager ought to know about, and when he does, he is self-conscious and ill at ease, and goes away without half stating his case and irritated because of a feeling that he has been put at a disadvantage.

Unit Subdivision of Plant

Now, when the works manager has learned to find his way around without a guide, and the men in the shop have learned to take his presence as a matter of course, let him start the first forward move by analyzing his shop conditions and personnel, and laying down a definite organization. Of course, any organization that he may plan in the start will be changed in minor details many times, but there is no reason why the main structure should not remain practically the same as originally planned.

It is understood of course that what one is seeking for in this move is to subdivide the entire plant into a number of different units, placing a definite responsibility upon the head of each unit, and it is understood that the heads of these units will be respected in the positions they hold, or, in other words, there must be no splitting of authority or going over one's head with orders of any sort. For instance, the giving of orders directly to a workman by a general foreman or anyone else higher in authority is a serious breach of discipline, as it soon weakens the foreman's standing with the men to such an extent that he soon becomes useless as an executive. The same thing holds good, in a much greater degree, in the relationship of the owners to the head of their manufacturing operations. This may seem an insignificant point to bring out in a paper that is only touching the high spots, but I believe that many shops in need of reorganization owe 90 per cent. of their troubles to the failure to fix definite responsibility and live up to it.

This sub-division of the shop is readily visualized by means of an organization chart which will give the layout of responsibility as well as the physical layout. In making up this organization chart, I have found that the easiest way is to use round metal-bound cardboard tags distributed on a large drawing board (see Fig. 1).

The first tags made out should contain the names of the main departments. The average typical shop should have the following departments: Works Office, Engineering Department, Pattern Shop, Tool Design and Storage, Tool Making and Repair, Plant Engineering and Power, Machinery, and Erection.

This division of the shop is merely typical, and it must be understood that all sorts of variations are necessary, due to the varying factor of the personnel from which the organization has to be made. I might say here that I am a very strong believer in using the personal material at hand rather than replacing the old employee by new help.

The next step is to add to each department tag the name of the man who is selected to have charge of that department. With these tags spread out on the drawing board, with two more tags for the Works Manager and an Assistant Works Manager, and a number of smaller tags for the subdivisions of the major departments, the general shop organization begins to take shape.

I want to insert here that the Assistant Works Manager should be capable of assuming the work of the works manager in the latter's absence from the plant, and both the works manager and the assistant should have as few routine duties as possible. Their time should be spent in planning improvement and in bolstering up the weak points in the organization. A great many men get the idea that organization once done is done forever. On the contrary, the only organization that is final or complete is a dead one. I have cleaned up two plants after several firms of so-called efficiency engineers had had a shot at them. They had gone away after a time, leaving a mass of charts, forms and card indexes which were supposed to have accomplished a complete reorganization. Even if this reorganization was sufficient for the needs of these plants at the time they left, which it was not, it would be foolish to suppose that it would automatically administer affairs for an indefinite period. The business that is managed by live men is always subject to profitable changes.

Analysis of Departments

The balance of this paper can be covered by an analysis of these departments. First, the Works Office. This, to my mind, is the most important division of all; if I had to choose between a poorly equipped shop with a good works office and the best equipped shop in the world with a poor works office, I would choose the former. The head of this department should be an understudy of the assistant works manager.

The greatest fault in choosing a man for the head of the works office is getting a man who is too one-sided. Often an accountant is chosen, and he fails to appreciate the true relationship of the office to the shop; if a man of purely shop experience is chosen, he fails to understand the importance of records. He should therefore have some accounting as well as shop and engineering experience. He should have an imaginative and inventive mind to originate new forms and apply mechanical devices

which insure greater accuracy and reduce the amount of labor. In this short paper it is impossible to go into details as to the possibilities of this position, but I have in mind a case where a man of this sort, through clever adaption of methods to the needs of his office, in two years' time reduced a working force from thirty-five to twenty men.

Works Office Subdivisions

The Works Office is divided into four divisions: first, Time and Employment; second, Cost and Inventory; third, Stock Control and Receiving; and fourth, Planning and Tracing.

The Time and Employment Department takes care of hiring men, application files, changes in wage rates, etc., and making up the payroll. This section also has charge of the department time-keepers maintained for the sake of accuracy of records and efficiency of foremen. The workman or foreman is never allowed to handle his own time records. In conjunction with the employment department, I have found it a benefit to the shop at large to employ a medical man and instal equipment to take care of all injuries and illness that may occur in the shop.

The Cost and Inventory Department should be able to show the cost of any job at any stage of operation, and the exact profit from the complete job. It should further be able to analyze any of the figures into direct wage, burden, material, etc., and also its records should show by comparison all previous jobs of the same sort, and, without being called upon, it should call the attention of the works manager to any unusual discrepancies in these comparisons. There should be the same type of comparison of the various accounts of indirect expenditure.

The Stock-Control Department should have charge of issuing shop orders, ordering from purchasing agent all raw material and finished material in proper quantities and in sufficient time to get the finished product on a specified date, receiving raw and finished stock, as well as storage of parts finished in the shop. Special effort must be made to secure accurate accounting of all material, as this is just as essential to the right operation of a shop as the cash balance is to a bank.

The Planning and Tracing Department establishes the order of progress of work through the shop. This department must be able to show the location of every job in the shop within a half-hour of its movement from one operation to another. It is possible to accomplish this by very simple methods. Two or three men following these records and kicking loose the dead ends, were able in one shop to lessen the number of jobs in the shop at one time from over 25,000 to less than 7,000, in addition practically eliminating the shortage of finished parts at the point of erection. When the time is ripe for time study and the establishing of standard times, this will be one of the functions of the planning department.

Engineering Department

In the Engineering Department all engineering information regarding specification has its beginning. The best arrangement is to separate the Chief Engineer who is responsible for design entirely from that section which issues the specifications to the shop. The chief engineer then has charge of the design and improvement of the product, including action on all changes suggested from any source.

The specification section takes on the work of detailing, tracing, checking, indexing, filing, making blueprints and parts lists, making bills of materials and issuing them to departments requiring them. Standard sizes should be established for all drawings and the straight numerical system identification used. For detail work one piece only should be shown on a sheet. Details should be drawn to scale, close measurements expressed in decimals and the working limits stated on each drawing. Dimensions should be so complete that the machinist does not have to do any figuring in order to find any measurement.

Assembly drawings must be furnished for each assembled unit. The assembly drawing must show the piece number of the details that go to make up the assembly, but without any dimensions of these parts being shown. I have found that showing several details on one sheet or working from dimensioned assembly drawings is bad practice. They will slow up the work in the shop and are the cause of a great deal of scrapped work.

New designs should be gone over by the chief engineer, chief draftsman, works manager and his assistant before being detailed, and the details should be criticized again before going to the planning department. It is much easier to rub out mistakes on the drawing than it is on a casting in the shop.

The Pattern Shop has the making of new patterns and the repairing of old ones, also the pattern storage and location records of patterns in the works and at the various foundries. I wish to make a point of the equipment in the pattern shop, which should be the best obtainable. There is no profit in working high-priced men on weak-kneed tools. If patterns are to be used for quantity production, ease of molding and long life should be considered in building them, but where a limited number of castings are to be made, no more time should be put on them than absolutely necessary. Lack of attention to either one of these details has caused large losses to many concerns.

Tool Design and Storage Department

The Tool Design and Storage Department takes up its work at the point where the drawings for parts to be manufactured leave the planning section of the works office. Any new jigs or fixtures required for the sake of interchangeability or economical manufacturing are designed and ordered by this department. This department is also responsible for storage, indexing and

checking of jigs and smaller tools in the tool cribs in the shop, and requisitioning the purchase of small tools—taps, cutters, drills, emery wheels and so forth. The Tool-Making Department will build all new jigs and keep up repairs on old ones. The sharpening of all small tools, milling cutters and reamers must be done in this department, and under no consideration by the workman using them.

Plant Engineer

The Plant Engineer in conjunction with the power plant is an arrangement seldom found in any shop. By a plant engineer is not meant a steam or electrical engineer, but a man with mechanical-engineering training who is responsible for the physical upkeep and improvement of the plant and the use of power. The opportunity which a man in this position has for saving money and increasing output is very great. The locating of all machinery, shop furniture, line shafting, piping and wiring, must pass through his hands. In one shop the writer had charge of, the load on the power plant was rapidly going beyond its capacity and steps had already been taken to install new equipment that would cost many thousands of dollars. By installing ball bearings and rearranging shafting, the plant engineer was able to reduce the load over 40 per cent. at a cost of 15 per cent. of the cost of a new power plant. There was also the saving in the cost of operation which the new power plant would have entailed.

The Plant-Foreman's Department is answerable to the plant engineer. The work that the plant engineer performs is usually taken on in a more or less slipshod manner by the heads of various other departments. He should have charge of the millwrights, oilers, belt men, pipe fitters, electricians, carpenters, crane operators, hookers, laborers, watchmen, janitors and shippers, and is responsible for the cleanliness of the plant, both inside and out.

Inspection, Machining and Erection Departments

The Inspection Department must be answerable to the works manager or his assistant only. In no case should the inspectors take instructions from any of the machine or erection-department heads. They must pass judgment on all work in process as well as the finished product. The inspection may be carried out either directly on the floor or in a centrally located inspection room. This depends more or less on the nature of the product.

The Machining Department may have one general foreman, with his assistants in charge of the subdivisions. These assistants have instructors under them whose duties comprise seeing that jobs are properly set up, tools properly selected, and proper feeds and speeds are used. There should be about one instructor for every ten men. Supervision of the machine work must be entirely

separate from the erecting department.

The writer is a firm believer in placing machines of a kind together; that is, lathes in one section, drilling machines in another, and so on. It keeps down the amount of the investment. It makes a better balanced condition, and the work goes to a foreman who knows more about that particular operation than an all-round man can ever hope to know.

The possibility of improvement in the various operations of the machine shop is never-ending, and the changes in machine tools are continuous, which is a fact that the works manager and his assistant should never lose sight of. Any new tool that promises more economic production should be thoroughly tried out and, if satisfactory, the old tool should be immediately disposed of, as it is cheaper to scrap a tool than to operate at decreased efficiency.

The Erection Department should have a general foreman, with the various units of assembly placed under his assistants, as, for instance, in a lathe shop there would be a head and tailstock department, carriage and apron department, etc., and a final erecting department of the sub-assemblies into the complete machine.

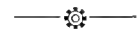

ZEEBRUGGE

ZEEBRUGGE is the seaport of Bruges, which derives its name from the fact that more than fifty bridges (Flemish "brugge") cross the many canals in and around the capital of West Flanders.

Zeebrugge is eight miles north of Bruges by rail, and six miles by way of the Canal Maritime, a modern waterway 230 feet wide, accommodating seagoing vessels with a draft of twenty-five feet. This canal terminates in the inner basin at Zeebrugge. The latter is protected from violent northwest winds by a crescent-shaped mole of concrete and masonry, a mile and a quarter in length. Crowning the land side of the mole are extensive warehouses, elevators and railway tracks. These elaborate harbor improvements were begun in 1895 and were under construction for twelve years, the cost exceeding \$8,000,000.

Zeebrugge was the outgrowth of the reviving prosperity of Bruges. Before the war this one great mart of the Lowlands had begun to take on a new lease of life, with its thriving market gardens, its ceramic factory and its extensive lace works employing 6,000 hands. It would probably never have achieved the size and prosperity of its thirteenth century fame, when it is said to have had a population of 200,000, but it numbered more than 50,000 thrifty people in 1914, including a colony of nearly 3,000 English.

Zeebrugge is fifteen miles northwest of Ostend and sixty miles northwest of Brussels. One mile south of the harbor, on the road to Bruges, is an enormous old barn with great oaken beams, dating from 1280, the only relic of the once wealthy and famous abbey of Ter Doest.

EDITORIAL CORRESPONDENCE

Embracing the Further Discussion of Previously Published Articles, Inquiries for General Information, Observations and Suggestions—Your Co-operation is Invited

APPEARANCES, GOOD AND BAD By A. L. Haas.

HERE is a proverb which states that appearance is apt to be deceitful. Be that as it may, so long as human nature remains unchanged, externals will continue to challenge criticism and exert an influence which may or may not be beyond their real worth.

National characteristics affect the matter; certain traditions have sprung up and these have a sub-stratum of fact. Solidity and durability are apt to be overlooked, if the less important finish is absent.

First Impressions Lasting

From a commercial, no less than a human viewpoint, first sight represents a great deal. Suitability to intended purpose is a prime consideration, but attention is first attracted and the eye of a customer focused by external finish even where this is not a solid asset or is bound to disappear in use. It is commonly assumed, and the assumption is warranted by fact, that real finish is a certificate of careful work not apparent, and great pains are taken to ensure attractive externals by firms who are proud of their product.

In a human sense any individual whose looks are smart has an asset of value, though we are all familiar with the man who can obtain job after job, but fails to hold any post for more than a brief period of time. The art of making a good impression is perhaps a gift but the acquisition of sufficient manners to avoid misapprehension is not difficult. We shopmen do not need the graces of the ambassador of commerce, but this is no excuse for lack of common politeness, whether to a superior or inferior. In fact, in daily contact the power of getting willing in place of grudging assistance from above or below is dependent upon a cheerful and mannerly spirit. In brief, it pays to be polite even to the most churlish. That tact, which avoids all cause of offence by sensing the other man's mind, is among the rarest of virtues and is a natural gift, but sufficient for daily use need involve no strenuous study.

The bird of passage who drifts from shop to shop obtains experience denied to the sticker who is in most instances the better man. The experience meant is that of interviewing prospective employers successfully. It is an art in which some men shine. From past interviews he knows very nearly what questions will be put and what answers to give. It is a most difficult thing sometimes to extract the needed facts from a really good man, who is deficient in such experience. It is like a boilermaker at home trying to explain a job to a friend—words fail—the fire shovel and a piece

of French chalk say more in half a dozen lines than an hour's description.

Technicalities and Sales

From similar reasons the practical technician fails rightly to apprehend the question of sales. The more familiar he is with the details of manufacturing, the worse missionary he is likely to make in pushing their merits. It is a little curious, but none the less true, that the majority of those having the power of purchase are either non-technical or else more in a different field of effort. As a consequence, it is often those very elementary facts regarded as childish by the practical man which are required. Another matter is that the technician fails to perceive that his specialized knowledge was obtained over a term of years by slow degrees. His fault is often that he expects those totally unfamiliar with his wares to take in right away the whole of their merits.

If the advertising expert be watched, it will be seen that in place of crowding his space with all the merits and reasons, he confines his attention to one or two only. Later he uses up the other reasons singly or in pairs, varying his matter but never confusing the casual reader by making him study, or compelling him to use a magnifying glass to assort all the labels and pointers. The reasons must be sufficient, adequate and pointed, the ad must be arresting, he does not attempt to make a convert of his reader by a single explosion; on the contrary, he stimulates his interest by repetition and variation. Advertising is a matter of appearance, but of selective appearance. Salesmanship is, of necessity, of a more intimate complexion, dependent most often upon the reaction between native and nature.

No salesman may give way to exasperation, and argument is one of the worst methods of gaining an order. It is not words, lectures, speeches, or exposition which tells, but a growing conviction in the customer's mind, dependent upon the whole salesman, not necessarily upon his tongue. If the reader will cast his mind's eye backward he will realize that it is less words than quite another quality which persuaded.

Confidence a Keystone

Commerce is confidence, the entire business world hangs upon credit, upon credibility, upon faith justified by past facts.

From the retail shop to the largest manufacturing concern, the appearance cultivated is that of confidence.

The biggest advert of the lot in the appearance of the goods on delivery and subsequent satisfaction in their use. Repeat orders and the establishment of what commercially is termed good-will

is worth many sacrifices in the initial stages, many things legally enforceable are suffered that relations be not disturbed. Customers who silently suffer are not friends, the man to encourage is the man who complains; it is worth spending a little time to get him pleased. Treated otherwise, he becomes often an active enemy and a missionary for a rival firm; placate him, reason with him, convince him, and another good-will link in the chain of business is established.

Mechanics and Beauty

The mechanical sections of the universe are blamed for their neglect of beauty; it is strange to the engineer to hear the artistic value of mechanical products traduced. The fact is that those who complain lack the knowledge necessary to appreciate. A power unit, a bridge, a machine, a boiler—all have artistic possibilities rightly viewed. The ancient Greeks had one word meaning both artistic and fitting and any thing correctly designed must have one merit, proportion which lies at the base of all artistic work. Art so-called concerns itself with appearance, largely with external decoration; strength and rigidity, power to resist stress are not an artist's province.

The utilitarian aspect of a machine or hardest shelled of practical men can find beauty in the products of his craft—proportion, line, and fitness find in him a qualified judge. To him such things make an instantaneous because an educated appeal. He knows and knowing can afford to smile at the criticism that he sins against art by mechanical effort. One thing certain is that the craftsman in every age has been the man upon whom the work of that age has rested, and that craftsmen of past ages would be the first to appreciate the craft of to-day.

Appearance Suggests Merits

The appearance of the finished goods has a commercial value, their design satisfies fitness to a destined end, their workmanship reveals itself by the finished look to a trained eye. Care and skill are manifest externally, near enough is not good enough. It is worth effort to attain good looks, they are a passport to favor. Moreover, that concern taking pains for appearance sake helps to cultivate a feeling of proper pride in the staff, which, insensibly and without addition raises in its turn that invaluable internal asset inside the firm—reputation. Than which it is safe to say nothing is worth more to a maker, whether his produce be implements, machines, or aught else. Reputation inside the firm and outside, along with good-will among its customers, depends in the main upon appearances which need not be deceitful after all.

A KINK IN REFITTING LATHE BOXES

By H. D.

IN fitting up half boxes for lathe headstocks it takes a good deal of time to make the brasses a perfect fit on the spindle, and at the same time have the two halves tight together. It is not considered good practice to use liners between the halves (though this is done on most all other high-class work), nor is a gap permissible. One concern that did rebuilding and turned out an average of a lathe a week followed the practice of planing the boxes off, so that when they were finally fitted (scraped) to the spindle, there was from .003 in. to .006 in. space between the halves. The face of the brasses was then tinned over, and this solder filed down until the fit desired was obtained all around. The solder filed easier and quicker than bronze, and the coating made it easier to fit up when the round part became so worn in service that refitting was necessary. No reason was ever found to condemn this method.

and at the end of that time an examination showed (of course) less wear from the babbitt gib, and the gib itself had worn only a few thousandths in what was the equivalent of a year's running.

So the babbitted gib was adopted and a substantial saving resulted. With this soft metal construction, a greater thickness of gib was adopted, the thickness being 11-16 in. The saddles as cast came with the gib side cored to the 60 deg. bevel, so that no planing was needed on this side, effecting a further saving. In babbitting, the table was C-clamped in place and saddle and table then turned up on edge, so that the space to be filled was most accessible. The set screws were put in and left projecting about 1/4 in. on the inside so that their pockets were cast right around them. Caps were put across the ends, and the piece was ready to be poured. Owing to the ample space, easy to pour into, no failures resulted. Old type metal was used. This makes a splendid bearing, and can be procured at an attractive price.

per minute is necessary to transmit 20 horsepower?

Connect the 2,000 (column A) with the 20 (column B), and locate the intersection with column C, then from that point of intersection run over to the 4-ply mark (column E), and the intersection with column D will give the answer as 8 inches.

Again, if we had known the width and wanted to determine the ply, the method would have been about the same. It is so simple that I am sure any reader will understand by merely inspecting the chart.

This chart is applicable to the well known belts made up in plies such as stitched canvas, rubber and Balata, and the range, it will be noted, is wide enough to care for any ordinary condition.

BABBITT WISDOM

By D. A. Hampson.

TO be successful in babbitting—

Avoid moisture and wear goggles.

Have the metal hot enough, but not too hot—the only right temperature is that when the babbitt will just light a pine stick—less than this is too cold to pour, more than this burns out the tin and injures the flowing and wearing qualities of the metal.

Heat more metal than you need—there will be less drop in temperature and no danger of the mould being only part filled.

Have the work as near the source of heat as possible—there is not the loss of temperature and of time and the danger

PASTE FOR OIL TIGHT JOINTS

By D. A. Hampson.

AN oil tight joint between metal parts which can not be conveniently packed or fused can be made by using a paste made of glycerine and litharge (oxide of lead). The powder is stirred in the glycerine until the consistency is like very heavy cream, and is preferably applied to the parts before assembling and the parts drawn together, squeezing out the paste as they are tightened up. If this cannot be done, the paste can be worked in at the edge of the joint, applying with a putty knife. It takes about two days for this mixture to harden ready for use. In one instance some sheet iron troughs, 15 feet long, were to be filled with oil and various shafts run in that oil. The ends of the troughs had to be castings set inside and held with screws. No satisfactory way of keeping these castings tight was found until the glycerine and litharge paste was used.

HANDY CHART FOR SOLVING FABRIC BELTS IN PLYS

By N. G. Near.

INASMUCH as charts are rare on the subject of power transmitted by fabric belts, the writer has taken it upon himself to produce something that doesn't mention the word "leather" at all. Usually we are told that a 4-ply stitched canvas belt is equivalent to a single leather

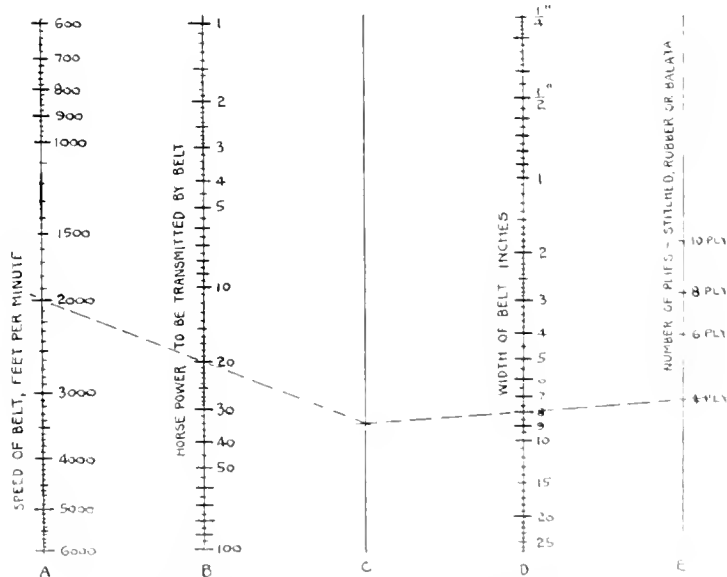

HORSE-POWER WIDTH CHART FOR FABRIC BELTS

BABBITT METAL GIBS

By H. Middleton.

BABBITT metal makes a satisfactory gib for tables, slides, etc., when conditions can be arranged for it. During the recent call for special machines, several hundred single purpose machines were built which had a sliding table similar to that of a milling machine. The work was such that there was little strain on the gib side of the table vee and the gib merely served to always keep the table up in perfect adjustment. The sides of the vees were of the common 60 deg. bevel, and the planing of the gibs was an item worth considering.

A scheme for a babbitt gib was conceived, and looked so good that two tables were tested out—one with babbitt and the other with the usual steel gib. The saddles were clamped on the planer, side by side, with the tables in place and the tables connected to the cross rail, so they could not move—while the saddles did. The planer was run a week this way

belt and then we are supposed to know the rest, but we usually have to hunt around in our handbooks for formulae on leather belts, the whole thing is thus highly unsatisfactory. With this chart you simply lay a straight-edge across twice, and the answer is found without difficulty. Knowing any three of the functions—speed, power, width and ply, we can easily determine the missing one.

For example, what width of 4-ply Balata belt running at a speed of 2,000 feet

of accidents with molten metal is reduced.

Don't try to use too much old lead if you "mix your own."

Make sure that the weight of babbitt is not going to break loose the caps or dams—it is always a good plan to have a helper ready to clap a bunch of waste over a dam that seems to be giving way.

Make a good big pouring hole, or more than one hole—a 1/4-in. hole is the smallest that anyone should attempt to use.

Drill as many holes to vent the mould as may be needed, remembering that air and babbitt cannot occupy the same space at the same time.

Pour the metal at the highest rate possible, spilling a little if necessary to get the speed—the faster it is poured the less it will cool and the farther it will run.

Coat the shaft with graphite or oil, or even paint so it can be readily removed after pouring.

Wrap the shaft with one or more thicknesses of paper when the work is not exact, and where reamers are not obtainable—it makes the shaft a running fit without scraping—the paper can be stuck on with shellac.

Heat the casting and the shaft with a blow torch or otherwise before pouring—the babbitt will be tighter in the box and the shaft will come out easier because the relative shrinkages are less.

Build up a good high dam or riser around the pouring hole and keep this filled—there won't be so many moulds "that didn't fill up" if this is done.

Get the shaft out of the babbitt as soon as can be after the babbitt has set.

Provide $\frac{1}{4}$ in. or more of space to be filled all around the shaft.

Use genuine babbitt when the metal has to run in very thin places.

An old carpenter's plane is good to cut down an overflow of metal where the surface is broad.

Study the condition of each job, and, applying the above, become one of the "only eight men in the country who know how to pour babbitt."

Avoid any moisture, and always wear goggles.



RASP FOR SOFT METAL

By H. Coomber.

THE rasp shown in the accompanying sketch will be found very useful in cutting down aluminum, solder and other soft metals, as it does not clog up and cuts very quickly; metal-pattern makers will find it very handy in trimming of solder on gated work. It is easily made; a file of suitable shape is softened, and then the teeth are filed to the dimensions given, a six-inch half-round file being used for this purpose. It is best to leave the rasp soft, as it keeps the edge for quite a satisfactory length of time, and can be quickly filed up sharp again.

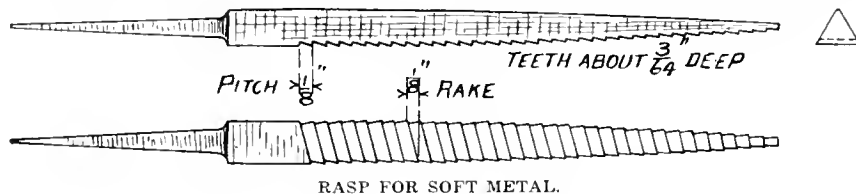

RASP FOR SOFT METAL.

This tool is best made from three-cornered, square and half-round files; the half-round and round will be found very useful in getting around a radius. The file may be bent, if desired, about two inches from the point, which facilitates getting at sunken portions of the work.

FACTORS GOVERNING COST OF POWER*

By George P. Roux

THE important question of cost of power is one that arises daily, and in making comparative estimates of cost of manufactured and purchased power, the engineer and the business man very generally omit a number of tangible economical factors, which inadvertently excluded give little or no value to the estimated figures intended to be used—and very unfortunately often depended upon—in deciding between manufacturing power on the premises or purchasing it from a central station.

A comparison, to be of any value, must be complete, true and accurate. All the facts must be laid bare, each one analyzed, and then weighed into a scale from which the verdict will be read.

Failure to follow this process will inevitably bring to the power user costly disillusion, otherwise called "experience," with no other remedies but to suffer the loss, or to adopt corrective measures.

Of the two propositions to be considered and compared, one, the manufactured power, requires in almost every case a complicated elaboration of data to arrive at the cost; the other is more scientifically defined by a few figures for specific electrical units.

Manufactured Power

Commonly, it is the practice to estimate the cost of manufactured power on the basis of cost of production, including operation and maintenance expenses. To this cost is added an item intended to cover the fixed charges in which are included interest on the investment, insurance and taxes, depreciation and obsolescence, all estimated with various degrees of accuracy.

Other important factors are very seldom given any consideration, and more generally entirely ignored, such as floor space rental or real estate, increase in assessment of property, stand-by or reserve generating capacity and the profit productive capacity of the investment in power plant compared with the same amount of capital invested in the regular business, as well as other minor items which we propose to review in detail.

In case of an existing isolated plant there are, as a rule, more or less complete information and data which per-

mit to arrive at a cost of production reliable only when the records have been kept accurately and properly over a period long enough to represent average normal operating conditions.

*Paper read before the Penn. Central Section, National Electric Light Association.

When a new plant is under consideration the task of the engineer is more complicated, and a complete knowledge of the power requirements followed by a thorough study of the situation peculiar to each case, is necessary in order to formulate an estimate of the cost of power.

After all the elements having a bearing on the cost of power, either directly or indirectly, have been carefully investigated and analyzed, and with the results in sight, the cost of power is to be determined in two parts: Cost of production, and fixed charges. To each one of these items must be charged all legitimate expenses without which the power plant could not be operated properly and continuously. The power plant should be treated as an industry within another industry, that is, all by itself.



MISCELLANEOUS

Steel and Iron.—Reaumur discovered the direct process of making steel in 1722 or thereabouts by immersing malleable iron in a bath of cast iron. A steel manufactory is said to have been set up by Benjamin Huntsman near Sheffield in 1740. It was about 1800, however, before steel fairly became the fashion. The greatest boost to the trade came from Bessemer in 1850.

IN preparing graphite for pencil-making, it is ground very fine, mixed with water, and passed through tanks to allow the heavier particles to fall, the finer particles passing onto five or six successive tanks, when, the necessary degree of fineness having been obtained, it is mixed with suitable clay which has been washed in the same manner. The mixture is submitted to further grinding, squeezed in bags to remove superfluous water, and forced through tubes to produce strips of the required shape and sizes, which when dried and baked, are ready for casing in wood.

Sunset at 12 o'clock.—The habit of counting 12 o'clock at sunset is very ancient. The Turks, Greeks, and most other people in the Levant have almost always counted 12 o'clock from sunset and to this day the common people cannot understand that their clocks have to be changed every day and not ours. The Turks have officially adopted meridian time, but only since the Young Turks came into power—that is, since 1908. The change was even then not made immediately. It encountered a great deal of opposition on religious grounds because the Mohammedan hours of prayer are regulated by the sun. And the common people still stick to the old system. Only in Constantinople and Smyrna are there many Turks who keep the official meridian time, and the great majority of people, throughout the Turkish dominions still count 12 o'clock as their ancestors have from time immemorial, at sunset.

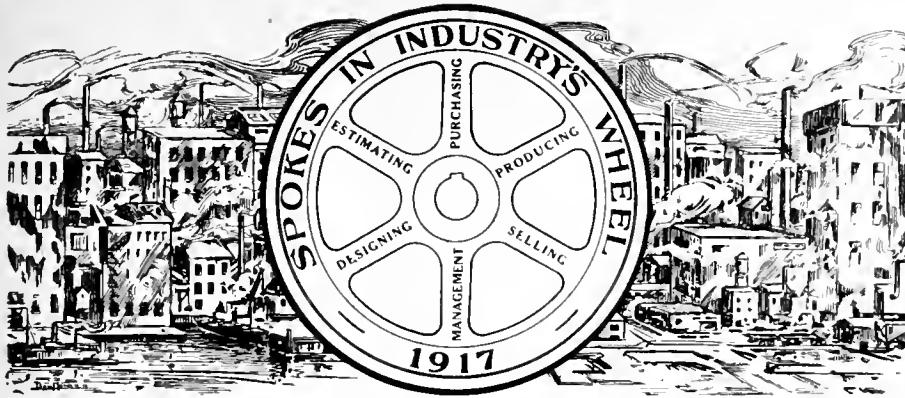

The constitution of industrial enterprise is largely departmental—"spokes in a wheel." This series of articles has for its object the featuring in a racy, interesting and instructive fashion, the training, experience and achievement of those who to-day are transmitting, effectively, energy in their capacity as "spokes in the wheels" of our metal-working establishments.

A. F. WHITE

NONE but the brave deserve the fair" is a time-honored saying, with a degree of truth in it which commends itself to most people. Similarly it can with truth be said that none but the industrious deserve the reward; and, happily, it can be said with all sincerity that in Canada, more than any other country, responsibility is merited by its holders. Not only so, but instances where world-wide experience has contributed to the success of individual careers are so numerous that one is almost justified in considering the rest of the world as a training ground for Canadian industry.

The travels and adventures of A. F. White may well be an incentive, not only to young engineers who may think of their duties only as duties, but to many ambitious and erstwhile restless spirits who realize the fact that engineering careers consist of a great deal more than sitting at a drawing-board or walking around a machine shop in brass-buttoned overalls. The village of Cam, in Gloucestershire, England, was the birthplace of our "Spoke," son of a building contractor. Bereft of his father's care and guidance at the early age of three years, the future engineer's boyhood was such as to develop a spirit of self-reliance and ambition, which were later to be reflected in his varied activities and accomplishments. When aged 13½ years, with a public school education behind him and a three-year scholarship to his credit, he deliberately sacrificed the scholarship to satisfy his desire to enter the engineering trade, and despite the wishes of his mother that the scholarship should be accepted, young White "got a job" with R. A. Lister & Co., Ltd., whose works at Dursley were two miles distant from his home. Here the youthful tradesman worked for eighteen months in the erecting department, receiving wages of one dollar per week, starting work at 6.00 a.m., stopping at 6.00 p.m., and walking each way. These conditions were deliberately accepted in spite of the knowledge that the regular apprenticeship of

six years could not be started until the applicant was 15 years old, this preliminary period, therefore, actually making the ultimate apprenticeship equal to 7½ years.

Agricultural engineering was the principal line of the Lister Co. at that time, and as it did not appeal particularly to our "Spoke," he became apprenticed in due course to the Dudbridge Iron Works,



A. F. WHITE.

Ltd., of Stroud, a premium being paid and agreement signed, with remuneration increasing from a dollar and a quarter per week the first year to three and a half dollars per week at the end of the term. Steam and gas engines, hydraulic and pumping machinery, etc., of high-grade design and workmanship were produced at Stroud and during four years of apprenticeship evening classes at Stroud Technical School were attended three

nights per week, followed later by a post-graduate course of mechanical engineering. Outside jobs possess a peculiar fascination for apprentices, not only on account of the change from shop routine, but because of the added prestige enjoyed by the lucky youth. It was significant of Mr. White's ability that at this time he was sent out in charge of some "fair-sized propositions," and to this day he considers this to have been the best part of his training,—being thrown on one's own resources and placed in various difficult positions at an early stage.

His work in this direction received full recognition at the Paris Exhibition in 1900, when his work in erecting and fitting up the firm's exhibit of gas engines won for him a bronze medal and diploma from the authorities, a silver medal being awarded the firm.

At the age of 24, the position of assistant general foreman was reached and held for three years, followed by a year and a half in charge of the mechanical engineering department of W. G. Aston Co., London, when the position of general foreman with the old firm at Stroud was accepted. The manufacture of gas and oil engines had now been gone into almost exclusively by the Dudbridge Iron Works and experimental work formed a large part of Mr. White's duties, resulting in many improvements, two of which, the White flexible magneto and ignition lighter were used extensively for a number of years by English and French engine builders, a handsome royalty being received through his employers on account of these patents.

A special adaptability for trouble jobs and outside work resulted in Mr. White making visits to every country in Europe, much of the work being for continental governments, some of whom are now our enemies. Turkey was the scene of several visits, one job being the supervision of a semi-Diesel installation in the First Turkish Arsenal at Salonica for the the Young Turk government. A producer gas engine plant was also installed at Macri, on the Asia Minor coast, which was the first and only engine of any kind within a radius of 200 miles. The oil fields of Baku in South Russia were also visited, several large gas engines being installed here, while Algeria was also the scene of further efforts.

A desire to see the Western Hemisphere was the not unnatural outcome of this travel, and a visit to the States resulted in joining the Foss Gas Engine Co., Springfield, O., where he successfully filled the positions of draftsman, chief tester and experimenter, trouble correspondent, sales engineer and assistant chief engineer. Canada, however, as in the case of many other Britishers, was to be his ultimate destination, the Canada Foundry Co., Toronto, securing his services as chief of gas engineering department; his two years stay with this concern being featured by the design of a complete line of gas producers.

Shortly before the war started, Mr. White became general superintendent for Marsh & Henthorn, Ltd., Belleville, Ont., and like most other plant executives in

this country has been actively engaged in the manufacture of munitions and the building of equipment. Numerous opportunities have arisen for the exercise of his inventive resources, resulting in a complete line of munition tools. Practically every machine at present in use on shell work by his firm has been built by them, and many of his mechanical ideas have received notice from the technical press.

Mr. White is married and has one daughter who, with her mother, shares her father's fondness for such relaxations and pastimes as motoring, fishing and boating, all of which can be enjoyed to advantage in the locality of Belleville. In the matter of religion Mr. White is Anglican, but at present is not prepared to subscribe to any particular political creed. His views on matters military are quite pronounced, however, as evidenced by his holding a commission in the 15th Argyle Light Infantry of Belleville. His advice to young men is short and concise with the full merit of personal experience behind it—"Work hard and study, stick to engineering right from the start, and read every periodical and text book available. Make up your mind, keep it made up, persevere, and success will come."



MACHINE SHOP LIGHTING

NOTWITHSTANDING individual beliefs to the contrary, most of us are creatures of habit to such an extent that we are daily guilty of gross inconsistency. A shining example of this, says the *Travelers' Standard*, is the persistence with which machine-shop owners cling to the use of local lighting units for artificial illumination. It is true that some managers are aware that a system of this kind handicaps the workmen with regard to both safety and production; yet, against their own better judgment, they often yield to the demands of the workmen for local lighting units affixed close to the working points, and in all too many cases of this kind no reflector equipment is used to protect the eyes. Wire guards are often provided to prevent lamp breakage, but these afford no protection whatever to the eyes. From this it might be almost inferred that the breakage of an inexpensive lamp is considered more important than an injury to the workmen's eyes—organs that are irreplaceable at any price, and that are the greatest protection against accidents that mankind possesses.

Unshaded Local Lights

It is important for the machine-shop owner to realize that unshaded local lights are inefficient and harmful, and that they must be scrapped in the same way that obsolete equipment of other kinds is scrapped. Every machine shop that is equipped with a lighting system of this kind is losing money through two channels—first, through a low production rate attended by a high spoilage percentage, and second, through a high accident hazard and therefore a needlessly high accident rate. A simple experiment

will illustrate the truth of these statements. Take a needle in each hand, grasping one near its eye and the other near its point, and with a strong unshaded light source (say, a 40-watt Mazda lamp) suspended 12 or 15 inches in front of the eyes, try to place the point of one needle in the eye of the other—the light source being maintained in position between the hands and the eyes, and as nearly in the line of vision as practicable. Next, interpose a piece of cardboard between the lamp and the eyes, so that the light rays are effectively screened from the eyes, and again place the point of one needle in the eye of the other. It will be found that this can be done quicker and with fewer pricks from the needle when the eyes are shaded. The same work is to be done in either case, and the greater time consumed in accomplishing it with the unshielded light illustrates the difference in the rate of production, while the greater number of needle pricks illustrates the increased accident hazard.

Specular Reflection

The evils of poorly-designed machine-shop lighting are not confined to unshaded lamps. Lighting units may be equipped with suitable reflectors, but may cause "specular reflection" on account of improper suspension height with respect to the work and the workman. "Specular reflection" is the kind of reflection that occurs at a mirror or at a polished metallic surface—the term being used to distinguish reflection of this kind from the diffuse, irregular reflection that takes place at the surface of every object that we can see. Specular reflection is particularly objectionable because it produces the same kind of effect upon the eye that is caused by placing a source of illumination immediately in front of the eye.

A person may look into a mirror, for example, and see a lighting unit behind him, in all its brightness and detail, just as well as if he were directly facing it. This kind of thing often occurs in a machine shop, particularly when work is being done on a brightly polished surface. Such surfaces act as mirrors and care must be taken with regard to the horizontal location and the vertical suspension-height of the lamps, to prevent specular reflection from the work from reaching the workman's eyes while he is in his usual working position.

A particularly annoying, yet typical, violation of this principle consists in placing a lighting unit, with a proper reflector equipment, over a milling machine, in such a position that when a fine cut is being made the bright metallic surface will reflect the light into the workman's eye. The effect is exactly the same as if the man were lying on his back and looking directly into the reflector. His vision is affected adversely and as he is quite likely to think that the remedy consists in providing a supplementary local light, he usually asks for one and often receives it—perhaps without any reflector equipment whatever. This in no sense cures the ill, but rather intensifies it, because while formerly he

had one unit causing specular reflection, he will now have two, and in addition one of them will shine directly into his eyes. It is doubtful if his ability to perform his work efficiently has been increased. The chances are that it has been reduced, instead; and the likelihood of his receiving an injury has certainly been augmented.

The conditions suggested in the foregoing paragraphs are to be found in the majority of machine shops to-day, notwithstanding the fact that improved methods of illumination are at hand, and well within the means of every shop. The remedy consists in employing a lighting expert, and equipping the building with lighting units in accordance with his specifications. A competent lighting authority will see that the lighting units are installed in such a way that there will be no serious eye-irritation, either from direct rays from the lamps, or from specular reflection; and the cost of making the changes will be negligible in comparison with the benefits obtained. These benefits are commercial as well as humanitarian. For example, a workman may be enabled to centre a drill exactly, with proper illumination, in half the time required with unsuitable lighting. Moreover, he will know that the work is being done correctly, and this is something he cannot be sure of with poor lighting, except at a considerable time-expense.

Localized General Illumination

Wherever illuminating engineers have been called to study the lighting conditions of machine shops, we find that in the main they have recommended localized general illumination systems as best adapted to satisfy the conditions. A system of this kind, as applied to a machine shop, provides for an evenly distributed, well diffused illumination of medium intensity, glare and specular reflection being eliminated by the use of suitable reflector equipment and by the installation of the lighting units at a proper suspension height. In addition to this, local lighting units are installed as near to the work as may be necessary. These units are likewise properly equipped with reflectors, and are so placed with respect to the work that they fulfil their function of providing light to see by, instead of shining directly into the eyes. It should be noted, here, that while these local units are not, as a rule, rigidly secured, yet they are arranged so that the workmen cannot change the position of them to any great extent. They are not to be confused with portable lights which are necessary for certain special machine-shop operations, such as boring and reaming, and which should be handled just as any other tool in the shop—that is, a portable light should be charged against the workman who asks for it, and when returned it should be carefully examined for defects in the insulation.

The system of lighting outlined is particularly efficient as a method of varying the illumination intensity to make it suitable for different classes of work in a machine shop. The intensity re-

quired in a modern machine shop may be as low as two foot-candles for buffing, grinding, sawing, drilling, and rough bench work; three to five foot-candles may be necessary for erecting, inspecting, assembling, planing, milling, shaping, and lathe work; and a maximum of ten foot-candles is often employed for fine bench work and for drawing. If the general illumination intensity is about one foot-candle throughout the shop, it is a simple matter to select lamps and reflectors of the proper size to provide the additional intensity required for any of the foregoing classes of work. Thus we avoid that accident-creating condition of sharp shadows and contrast, which is characteristic of a shop where purely local illumination is employed. The success of a localized general system of illumination depends on proper location of the outlets, suitable suspension height of the lighting units, and non-interference with these arrangements on the part of the employees.

Lighting Maintenance

After the system is installed it is essential that it be kept at its most efficient state by proper care and maintenance. The lamps and reflectors soon become coated with oil-laden dust, or become soiled from handling. They should therefore be cleaned frequently, and in order that the expense involved may be kept at a minimum, porcelain-enameled reflectors are to be preferred. A finish of this kind does not collect dirt readily, and it is easily cleaned.

Just a word regarding the question of natural light for bench work. In continuance of a long-established practice the work-benches are almost invariably placed parallel with a wall, though there does not seem to be any sufficient reason for such an arrangement. When the benches are set close to the wall all of the workmen face the strong, natural light from the windows; and if the benches are set out from the wall a short distance so that the men can work on both sides of them, the men on the side next to the windows will cast shadows over their own work, and to some extent over the work on the opposite side of the bench as well, and then men on the other side of the benches must still face the light. There may be well-founded objections to the use of short benches placed at right angles to the walls, but so far no machinist has advanced them to us.

With such an arrangement, just as much light will fall on the working point as with the usual layout, and, moreover, a workman facing at right angles to the incoming light will be in a much better position to observe his work than one who is facing the window directly. The aisle space need not be encroached upon by disposing the benches in this way, and since the workmen are out of the passageways they are less likely to be injured by trucks or by material that is being moved about by hand. New artificial lighting units can readily be installed, or existing ones relocated to suit the changed conditions. On the whole, the suggested arrangement appears to be worth consideration.

ORDERING COMMUTATOR BRUSHES
UNLESS the style, type, size and shunt equipment of a brush can be definitely given when brushes are ordered, the following information should be furnished the brushmaker, or the manufacturer of the machine, when an order for brushes is placed:—

1—Size of brush, in the following order:—Length, width, thickness.

2—Bare or copper-coated.

3—Brush angle; also if corners are square or chamfered.

4—State whether rotation is against toe or heel of brush.

5—If to be drilled for shunts, or countersunk, or both, give full particulars.

6—If to be equipped with brush-lifting devices, give full particulars.

7—State whether for one, two or more shunts, giving length of flexibles and styles of flexible terminals.

8—Specify if shunts or brush-lifting devices, or both, are to be either attached or supplied.

9—Give all information on the name-plate of the machine.

10—Give diameter of commutator (or rings).

11—State whether or not mica is undercut.

12—Give maximum number of bars touched by the brushes.

13—Give number of segments between centre of positive and centre of negative brushes.

14—Give number of poles (or brush arms) and number of brushes per arm.

15—State if machine is of commutating-pole or non-commutating-pole type.

16—Give style or type of holder.

17—If brushes in use have not proven satisfactory, state in what respect they have failed.

18—If convenient, forward a used sample of the brushes in service. It frequently happens that a more suitable brush can be prescribed and that an examination of the original brush will not only suggest a substitute having superior characteristics, but at the same time eliminate possible errors in brush dimensions, shunt applications and brush-lifting mountings.

19—Bear in mind that brushholders differ greatly in detail and that the application of shunts for either direct or alternating-current service must be specified; otherwise the shunts might interfere with the pressure springs and a set of brushes be rendered useless.

20—It is also well to furnish a sketch of the brush.

21—If for "try-out" purposes, state what service the machine is doing; hours of service; minimum, average and maximum loads, with duration of each; also if machine is subjected to gas or acid fumes, and what, if any troubles have been experienced.

From the above it must be concluded that if what is wanted is expected it must be made clear what is wanted. Even then it may not be available. Brush requirements are in no sense stable. It is wise, therefore, to encourage a receptive

disposition and to be ready for such advances in the art as may seem worth while.



CANADIAN MANUFACTURERS' ASSOCIATION ANNUAL

THE 46th annual general meeting of the Canadian Manufacturers' Association is being held during the present week—June 12 to 14 inclusive, in the Fort Garry Hotel, Winnipeg. The official programme is as follows:—

Tuesday, June 12

10.30 a.m.—Report of secretary; report of treasurer; president's address; report of Membership Committee.

2.15 p.m.—Report of Executive Committee; report of Insurance Committee.

8.30 p.m.—Reception and smoker.

Wednesday, June 13

10.30 a.m.—Report of Legislation Committee; report of Tariff Committee.

2.30 p.m.—Report of Transportation Committee.

3.15 p.m.—Motor drive for ladies.

Thursday, June 14

10.30 a.m.—Amendments to by-laws; election of officers and committees; resolutions.

2.30 p.m.—Boat trip.

8.00 p.m.—Annual convention banquet. The reception and smoker will be tendered visiting delegates by Winnipeg members of the Canadian Manufacturers' Association. Brief addresses of welcome will be delivered by his Worship, Mayor R. D. Waugh, of Winnipeg; Honorable T. C. Norris, Premier of Manitoba; and Mr. W. R. Ingram, chairman of the Prairie Provinces Branch. Replies will be made by Colonel Thomas Cantley, president; S. R. Parsons, first vice-president; and W. J. Bulman, second vice-president of the Canadian Manufacturers' Association. Entertainment of an informal character will follow.

The motor drive for ladies will be through the city parks to the St. Charles Country Club, where afternoon tea will be served.

The boat trip will be by S.S. "Kenora," down the Red River, through St. Andrew's Locks, to historic Lower Fort Garry, the site of the early Selkirk settlers. This fort, the property of the Hudson Bay Company, is retained in its original state, and is leased to the Winnipeg Motor Country Club, who have kindly extended courtesies for the afternoon.

The banquet speakers will include Sir James Aikins, Lieutenant-Governor of Manitoba; W. B. Lanigan, of the Canadian Pacific Railway Co., and H. W. Wood, president of the United Farmers of Alberta. It will also be made the occasion of the inaugural address of the incoming president.

The privileges of the St. Charles Country Club, the Pine Ridge Golf Club, the Bird's Hill Golf Club, the Fort Rouge Lawn Bowling Club and the Assiniboine Lawn Bowling Club will be placed at the disposal of visiting delegates.

The Winnipeg Industrial Bureau has arranged a business men's tour through the Province of Manitoba, leaving Winnipeg on the morning of Friday, June 15, and lasting for five days.

The "Alquist" Transmission Gearing for Ship Propulsion*

By W. L. R. Emmet**

The feature of the Alquist gear that renders it specially suitable for the transmission of large amounts of power is its flexibility, which permits it to yield at points under excessive pressure. This flexibility is secured by building the gear of plates between which there is a small clearance, this clearance allowing a slight lateral movement of the periphery which relieves the stress on the helical teeth. Some results secured in ship propulsion are appended.

THE designs described in this paper are based upon the inventions of Karl Alquist, an accomplished engineer formerly connected with the Turbine Department of the English branch of the General Electric Co.—the British Thomson-Houston Co. His gear inventions were first brought to the attention of the writer early in the year 1911. For some time previous Mr. Alquist had en-

gearing. The importance of high-speed gearing in connection with turbine and electrical applications is obvious and the General Electric Co. was working with a view to a development of the best standards.

of this character has been applied to about seventy-two sets where steam turbines drive electric generators of various types. Contracts have been closed for machinery for the propulsion of seventy ships aggregating 215,200 horse

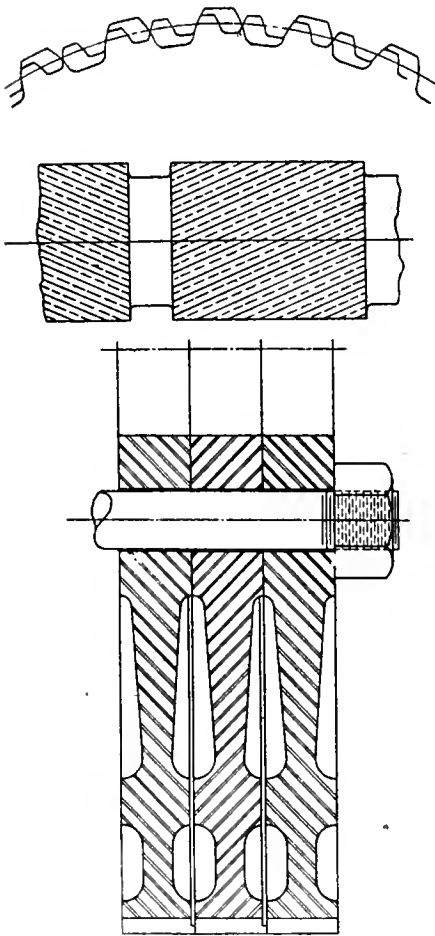

FIG. 1. CONSTRUCTION OF "ALQUIST" FLEXIBLE REDUCTION GEAR.

deavored to arouse interest in his methods in England and on the Continent but had accomplished nothing. At that time the General Electric Co. had not begun the commercial manufacture of high-speed spiral gears, but had for some time been conducting experiments to determine the limits of speed, pressure, etc., which were practicable with such

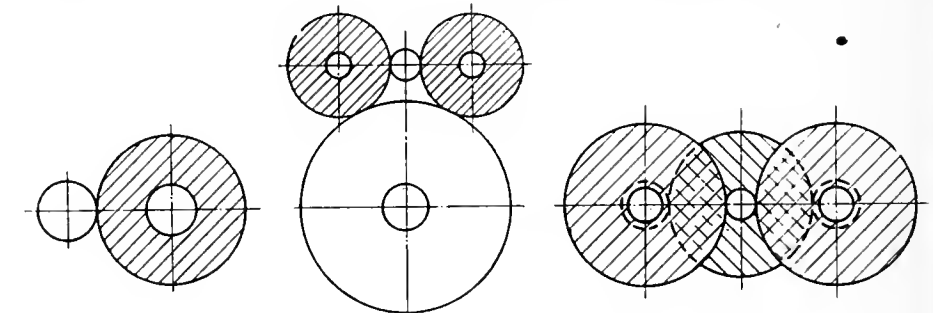

FIG. 2. VARIOUS ARRANGEMENTS OF PINIONS AND GEARS.

Certain features of Mr. Alquist's proposals appealed strongly to the writer, and arrangements were made with Mr. Alquist to come to America and assist in experimental developments along the line of his inventions.

The result of this undertaking has been that many sets of gearing have been built and experimented with exhaustively under a variety of conditions, and by these experiments certain standards of practicability have been established and extensive commercial developments have been undertaken. Gearing

power. Some of these electric generating sets have been in service one and one-half years and about seven of the ship sets are in service, some of them having made many long voyages. Among these are high-pressure cruising units for the battleship "Nevada" which have been in service for some time and shown very fine results. Among the ship equipments not yet completed are included the propelling machinery for Destroyer No. 69, built at Mare Island, and new propelling machinery for the scout cruiser "Salem." In all of this practical

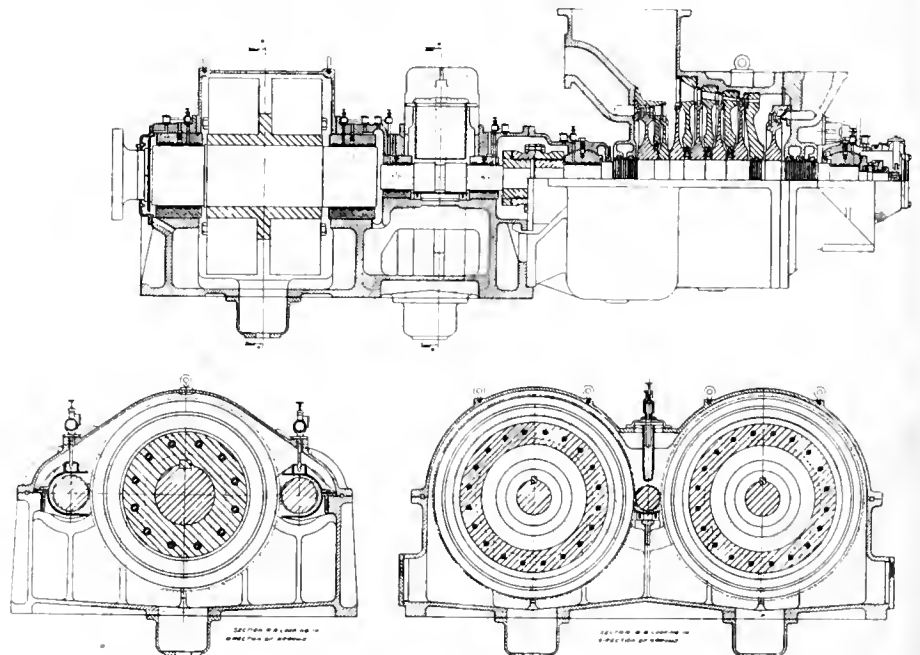

FIG. 4. SECTIONAL VIEWS OF TURBINES AND REDUCTION GEARS FOR SHIP PROPULSION.

**Consulting Engineer, General Electric Co., Schenectady, N.Y.

*From paper read before the American Society of Naval Architects.

experience no case of trouble with gearing has developed and no appreciable deterioration of gears has been observed.

One of the important reasons for adopting this type of gearing was that its design tended to afford a distribution of strains and means by which excessive strains would not be imposed upon any part through slight imperfections, distortions, or inaccuracies. The uniform success which has been accomplished with an entirely new product shows that this expectation has been amply justified. Some of the gears which have been used have been very imperfect, both in matter of material and workmanship, and have been used under extremely trying conditions. That they have not failed has afforded the strongest evidence of the general reliability of the method.

Character of Construction

The character of construction used in this gearing is shown by one of the drawings, Fig. 1. The gear is built up of a number of plates machined to a form which gives them the desired degree of lateral flexibility. These plates are put together, engaging solidly at the hub and also engaging on a narrow edge at the periphery. When so built together they form a solid cylinder which can be spirally cut in the ordinary manner. After cutting, the edge engagements are relieved with a small dividing tool so that each disk operates independently and is free to deflect laterally under the side pressure which results from its diagonal engagement with the pinion.

The parts are so proportioned that this lateral deflection can at no time involve fiber strains which could possibly cause destructive fatigue. A very small amount of this lateral deflection is sufficient to afford the desired distribution of load, and this amount can easily be given

torsional deflection of the pinion. There is also a tendency to inequality of strain on different parts of the surface through the lateral deflection of the pinion under load. These inequalities can be partially compensated by elevating the bearings or evening the pressure on them, but

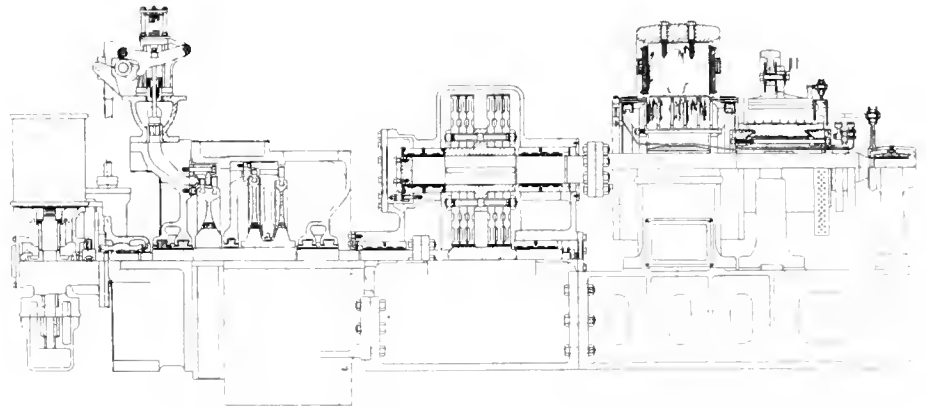

FIG. 5. CURTIS' 300 K.W. TURBINE GEARED TO GENERATOR 5,000 TO 1,000 R.P.M.

without approaching dangerous periodic strains.

Value of Flexibility and Load Distribution

To appreciate the value of this flexibility and load distribution, various peculiarities of solid and spiral gearing must be considered. In the first place, where gears are inflexible, there must always be a tendency to increase strain at the loaded end of the pinion through

this compensation can only be partial because the correction applies only to the two ends and not to the middle. Furthermore, the momentary and periodic strains on different points of solid spiral gearing may be seriously affected by vibrations of supporting structures, irregularities of machine work or gear cutting, and other causes. If for any reason such conditions cause any tooth or part of a tooth to receive periodically

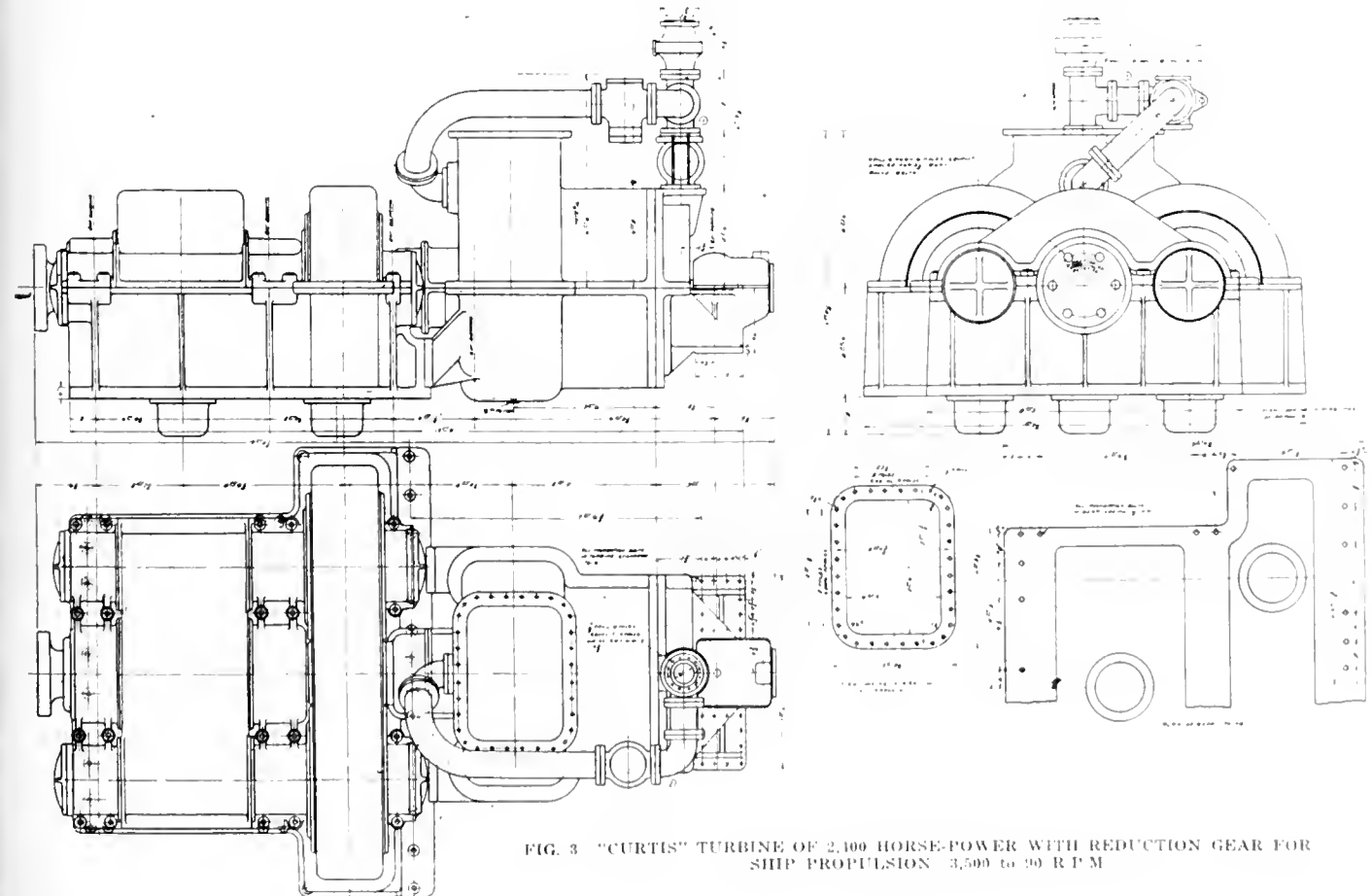

FIG. 3 "CURTIS" TURBINE OF 2,100 HORSE-POWER WITH REDUCTION GEAR FOR SHIP PROPULSION 3,500 to 90 R.P.M.

excessive strains, fatigue may result and a broken tooth may destroy the whole gear.

To obviate the possibility of breakage under such conditions, it is often desir-

With gearing of the Alquist type we can use very small teeth without any danger of incurring excessive strains on individual teeth, which might involve risk of the development of fatigue

cracks. In this connection it should be borne in mind that experiments have shown that the strongest steel, if subjected to periodic deflections, will break after a fibre strain of 20,000 pounds per square inch has been applied a million or more times.

Gear Applications

In the work which is now being done by the General Electric Co. gears of the type described are applied in three ways. First, a single reduction has been accomplished by engaging one solid pinion with a flexible gear of this type; second, by engaging a solid pinion with two flexible idlers, which idlers in turn engage with a solid large gear; and third, in a double reduction where a solid, high-speed pinion engages flexible gears on two countershafts, these countershafts carrying solid pinions, both of which engage a flexible gear on the same low-speed shaft. In these two latter applications the flexibility of the gears serves to equalize the loads between all of the driving points, and the use of a plurality of driving points on the large gear

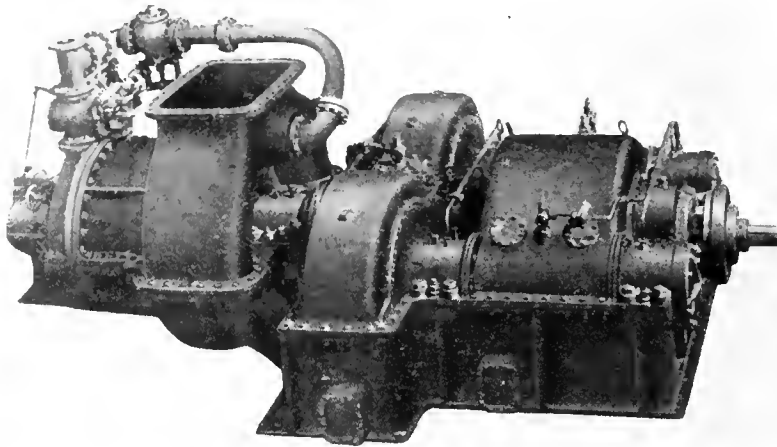

FIG. 6. "CURTIS" TURBINE AND ONE PLANE FLEXIBLE TYPE SPEED REDUCTION GEAR FOR SHIP PROPULSION.

able in solid gearing to use relatively large teeth in order that these possible irregular strains on teeth or parts of teeth will not involve danger of breakage. For other reasons, however, the use of large teeth is distinctly undesirable in spiral gearing. Spiral gears tend to engage by point contacts at or near the pitch line, and the ability of these point contacts to bear pressure without fatigue of the surface metal is governed largely by flatness of the surfaces engaging rather than by the size of the teeth carrying these surfaces. The flatness of the surface is a function of the pinion diameter and not of the pitch. If we double the number of teeth in a spiral gear we have twice the number of driving points in action, and the flatness of all of these points is the same in both cases if the pitch diameters are the same. These matters are illustrated in the sketches in Fig. 1.

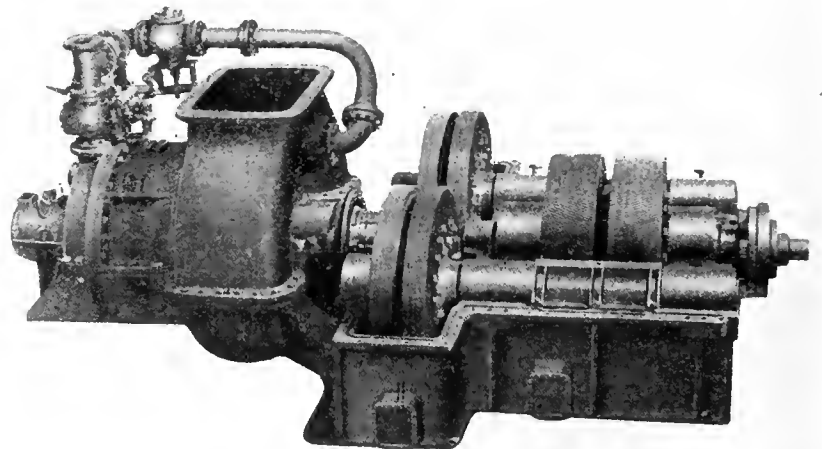

FIG. 7. "CURTIS" TURBINE AND ONE PLANE FLEXIBLE TYPE SPEED REDUCTION GEAR FOR SHIP PROPULSION, SHOWING CONTROL.

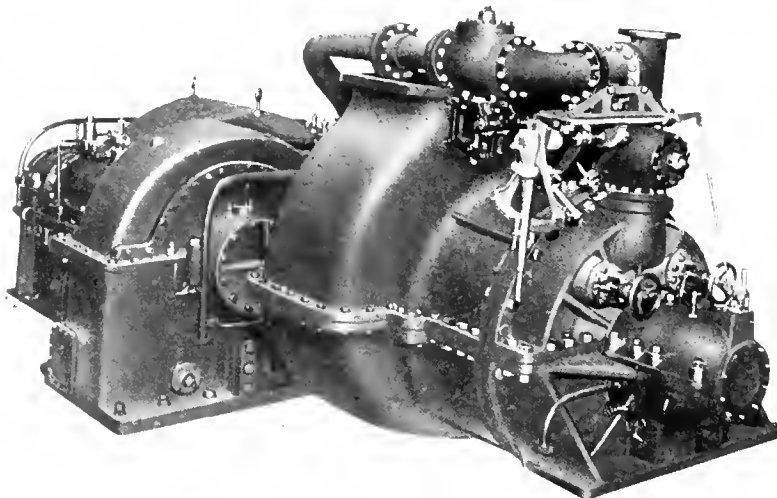

FIG. 8. "CURTIS" TURBINE AND ONE PLANE FLEXIBLE TYPE SPEED REDUCTION GEAR FOR SHIP PROPULSION, TOP HALF OF GEAR HOUSING REMOVED.

reduces the length of face necessary on that gear. These different methods of application are illustrated by diagrams in Fig. 2, and are also shown by the photographs and drawings of actual machines which are attached to this paper.

In both of these cases where a single high-speed pinion drives two flexible gears, other very positive advantages are accomplished. The pinion is relieved of bending strains, and pressure on the high-speed bearings is avoided.

Experiments have been made in Schenectady which carefully analyze the losses of high-speed gears under various conditions of load and pressure, and these experiments have indicated that low peripheral speeds are more efficient than high speeds. With solid gears, low speeds involve difficulties because they diminish pinion diameters and increase pinion lengths, thus complicating the troubles which may arise through deflection and torsion of pinions and pres-

sure upon pinion bearings. Since the flexibility of Alquist gears enables us to compensate easily for all possible degrees of torsional yield in the pinion, we can with such gears safely reduce peripheral speeds by making the gears longer and of smaller diameter. Such reduc-

oil in the same boilers under similar conditions. The "La Brea" is fitted with geared turbine equipment, and the "Los Angeles" is fitted with triple expansion engines of the best type. The "Los Angeles" is equipped with steam-driven oil-handling pumps of the ordinary type,

"La Brea" propeller operating at 90 revolutions per minute and that of the "Los Angeles" at 65 revolutions per minute.

The seventeenth voyage of the "La Brea" and the sixth voyage of the "Los Angeles" were made over the same course and at nearly the same time. The relation of fuel economy of these two voyages almost exactly corresponds to that shown by the average of all the voyages and tends to verify the accuracy of the whole comparison.

Cuts and data, courtesy of the General Electric Co., Schenectady, N.Y.



THE oldest writing material appears to have been composed of very finely divided carbon in a solution of an adhesive substance, which held the carbon in suspension and fixed it to the papyrus. Ink of this sort has been found on ancient Egyptian papyri, and was no doubt also in use in China at least as early.

AT one time the graphite used for making pencils was obtained almost exclusively from the Borrowdale mines in Cumberland, being mined in compact grey-black masses, cut into thin plates, then into rectangular sticks and cased in wood. The mine was guarded by an armed force, and, to maintain the monopoly, an Act was passed restricting the working to only six weeks in the year; for the remainder it was flooded to prevent theft.

If care be not exercised when sharpening lathe or planer tools on a wet grinding wheel, it is a very easy matter to destroy the cutting qualities of the tools, and this is often done without the knowledge of the operator until the tool is again used upon the work. Excessive pressure should not be used when forcing the tool against the wheel, as the heat generated below the cooling fluid raises the thin edge to a high temperature, and the action of the water causes sudden cooling, often creating minute cracks which result in the failure of the cutting edge when the same is brought in contact with the work. Proper attention should be given to keeping the wheel free from dirt so that it will cut freely without undue pressure in removing metal.

S. S. "LA BREA"

Voyage	Date	Total Distance in Knots	Average Speed in Knots per Hour	Total Barrels Delivered	Name of Port	Total Fuel Used on Steaming on Voyage in Barrels	Total Barrels per Knot Steaming	Total Barrels Used in Port	Total Barrels per Knot Steaming in Port	Time in Port, Hours	Barrels Discharged per Hour	Cost at 80¢ per Barrel per Knot Steamed in Port (Barrel)	Shaft Horse Power Hour	Pounds of Oil per Horse Power
1	Mar. 9 to 15 1916	650	9.5	62578	Oleum	574	.883	142	1.10	36 1/2	1714	\$0.88	116000	1.67
2	Mar. 15 to 26	2037	11.33	73600	Seattle	1459	.716	152	.79	37 1/2	1962	.632	505000	9.41
3	Mar. 28 to Apr. 6	2108	11.01	64676 8462	Vancouver Seattle	1584	.751	155	.824	26 13 1/2	2487 640	.659	530000	1.01
4	Apr. 8 May 16	9254.5	10.97	52109 19045	Talatal Antopagasta	6896	.745	117	.757	33 3/4 15 1/2	1544 1228	.605	232000	1.00
5	May 17 to 23	450	11.20	77292	Oleum	321	.713	134	1.01	39	1980	.808	118000	9.11
6	May 24 to July 1st	9196.5	10.65	71824	Antopagasta	6900	.75	109	.762	25	2660	.609	2200000	1.06
7	July 1st to Aug 9	9186	10.39	71791	Port San Luis to Antopagasta Chile and Return	6875	.748	107	.76	42.3	1697	.609	2230000	1.04

Average speed, 10.9 Total pounds of oil steaming = 8270000 Total shaft horse power hours = 802900 Pounds of oil per shaft horse power = 1.03

S. S. "LOS ANGELES"

Voyage	Date	Total Distance in Knots	Average Speed in Knots per Hour	Total Barrels Delivered	Name of Port	Total Fuel Used on Steaming on Voyage in Barrels	Total Barrels per Knot Steaming	Total Barrels Used in Port	Total Barrels per Knot Steaming in Port	Time in Port, Hours	Barrels Discharged per Hour	Cost at 80¢ per Barrel per Knot Steamed in Port (Barrel)	Shaft Horse Power Hour	Pounds of Oil per Horse Power
1	Apr. 9 to 15th	423	9.4	67674	Oleum	556	1.31	164	1.70	64 1/2	1099	\$1.36	74600	2.48
2	Apr. 16 to 25	1845	10.13	74739	Vancouver	1656	.897	218	1.01	33 3/4	2214	.808	394000	1.41
3	Apr. 27 to May 25	6549	10.22	73734	Panama	5579	.851	169	.877	46 3/4	1577	.701	1420000	1.315
	May 26 to 29	220	9.1	72372	Oleum	221	1.00	123	1.56	41	1770	1.24	390000	1.88
	May 30 June 27	6348	10.6	72538	Bal-Boa	5462	.86	159	.885	35	2072	.708	1460000	1.255
	June 29 Aug. 7-16	9151	10.24	71007	Port San Luis to Antopagasta Chile and Return	8293	.906	186	.926	56.3	1261	.74	2130000	1.31

Average speed, 10.27 Total pounds of oil steaming = 7310000 Total shaft horse power = 538000 Pounds of oil per shaft horse power hour = 1.320

tions of diameter diminish weight and improve efficiency, and the fact that the Alquist method makes such reductions possible constitutes one of its important advantages.

Ship Performance Comparison

The table shows a comparison of performances for two sister ships, the "La Brea" and the "Los Angeles," operated by the Union Oil Company of Los Angeles. Both of these ships are new, carry similar cargoes, and burn the same fuel

and the "La Brea" is fitted with a new arrangement of pumps driven from the upper deck by General Electric motors. The table illustrates the superiority of the oil-handling machinery as well as that which propels the ships. The horsepower hours given in this table are calculated from the propeller and hull data given by the naval architect of the Union Iron Works who built the ships, and based upon model tank experiments which were made in Washington. The models of the ships are identical, the

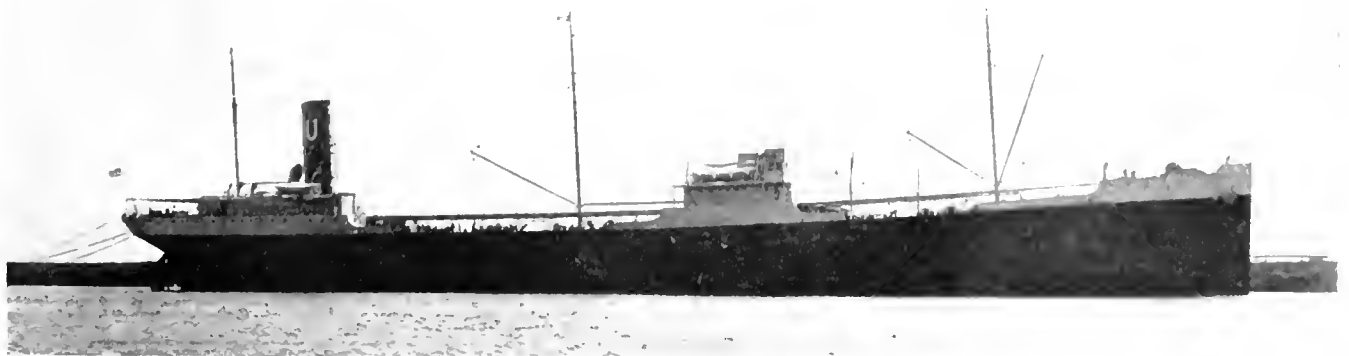

STEAMSHIP "LA BREA" PROPELLED BY 2,600 HORSE POWER "CURTIS" TURBINE DRIVING THROUGH "ALQUIST" REDUCTION GEARS.

CONTEMPORARY WAR ARTICLES

Embracing Information and Data Drawn from a Variety of Sources Relative to and Arising from the Prosecution of this Many-Sided European War

BRITISH MACHINE GUN FACTORY

THE recent slowing down of certain classes of shell production in Canada is said to be, to some extent, due to the enormous capacity of Britain's home plants which are understood to have approached well on to their maximum production. As is well known, shells have

neering, to whom we are indebted for the accompanying illustrations.

As mentioned by our contemporary, the object of publishing the matter is to demonstrate the ready response of manufacturers to meet capital commitments, the energy displayed by all concerned to ensure rapidity of construction and subsequent supply of munitions, and the

saw the entire establishment in complete working order and a steady supply of machine guns being despatched to the front. Satisfaction of an equally keen type is derived from the fact that all of the machine work in the making of these machine guns—one of the most intricate units of mechanical production—is carried out by women workers.

The rapidity with which this thoroughly substantial building was built is due in part to the suitability of the design, and in part to the organizing ability displayed by the various contractors' staffs, while an important factor was the co-operation of the Ministry of Munitions. The design was prepared by the Vickers staff with due regard to facilities for the securing of material. Only in small details was it found necessary to modify the original design.

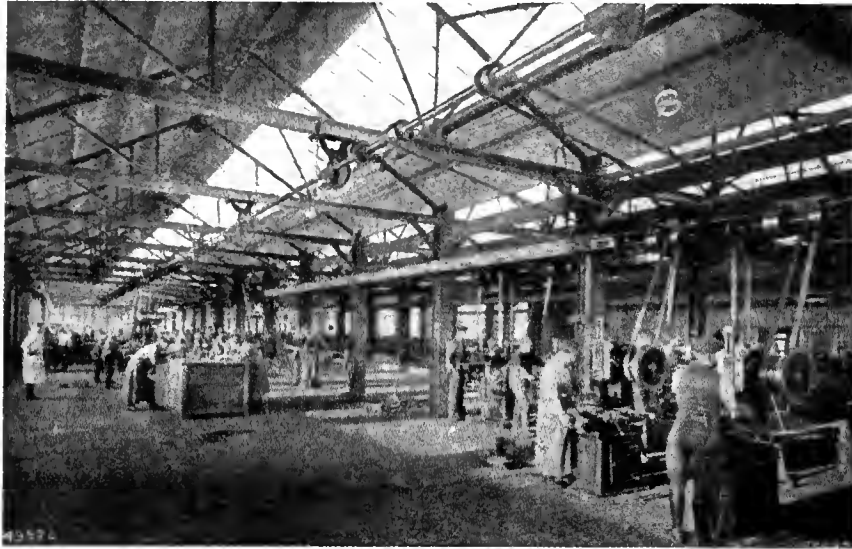

VIEW IN TOOL ROOM TEN WEEKS AFTER PLACING CONTRACT FOR ERECTION.

Main Building

The main section of the building as shown in plan view has a length of 337 ft. 6 in., with a total width of 75 ft., the spacing of the supporting columns for the upper floors dividing this into 6 bays of 12 ft. 6 in. The outside walls are of brick, with large windows having steel sash. Before the building had been advanced to any extent, it was decided to construct an annex, making the building L-shaped, as shown. The annex has a

occupied nearly all of our productive efforts in the munition line and admiration for unrestrained and successful efforts by manufacturing concerns have been limited to this work. In Britain, on the other hand, munitions and equipment of all types had to be produced in feverish haste, and after the situation was recognized and the flow of invasion stemmed, organized efforts were put forth on a scale, accomplished with a rapidity and crowned with a success of which little has become known. It is with considerable pleasure, therefore, that we are able to submit some interesting facts and data regarding one of the new Vickers machine gun shops which has recently been the subject of an article in Engi-

skill and resource to attain not only the fullest output from a given floor area, but the highest efficiency measured from the standpoint of man-power available.

Extent of Space

The floor area of the building which contains the plant, is nearly 2½ acres, and accommodates more than 1,000 machines of specialized type, driven by electric power transmitted through the medium of 6,000 ft. of line shafting and 40,000 ft. of machine belting. In spite of the immensity of the undertaking, manufacturing work was commenced within three months of the day when possession was taken of the ground—then a potato field,—while two months more

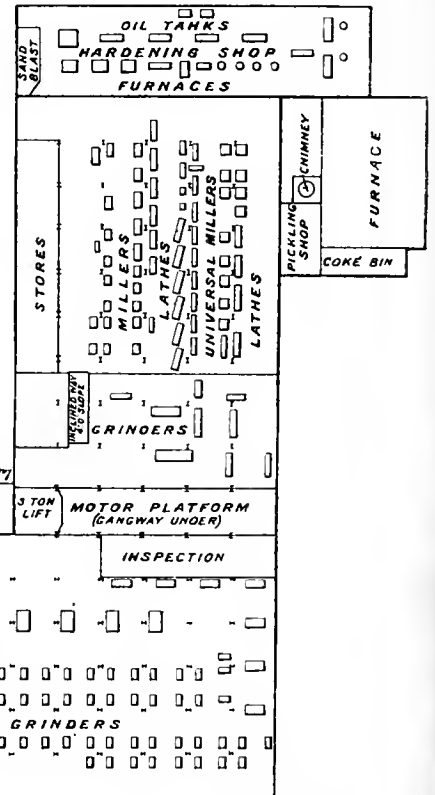

LAYOUT OF MAIN FLOOR SHOWING MACHINE GROUPING.

length of 125 feet, and a width of 75 ft.

The ground built on had a natural slope, and in order to avoid the delay

stores, etc., is shown in the plan view, which is also typical of the arrangement in the two upper floors. Fifty feet of the annex is at the same level as the

shop with furnaces and oil tanks. The middle portion of the main building is entirely a turret lathe shop, and the third portion is a mechanics' section except for the profiling work. In this latter section lathes and slotting machines are installed along with profiling machines.

On the first floor, about half the area is taken up with a large horizontal milling section, the machines being grouped in types—one block of 120 automatic millers being illustrated. The vertical milling department and the drilling department are also on this floor, which includes further a number of machines for broaching, spline milling, etc.

The top floor is a mechanics' section, half of the space being used for final assembling and the other half as tool room. The top floor of the annex is divided into a number of areas for accommodating finished parts, an inspection department, sand blasting, browning, etc. The two lower floors of the annex are used for the manufacture of small tools, and part of the top floor for the small tools store.

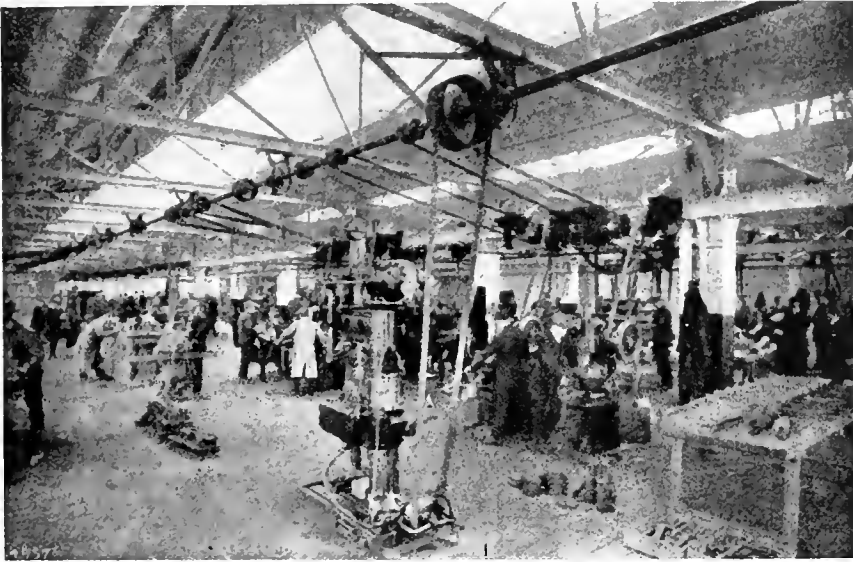

LATER VIEW IN TOOL ROOM WITH MACHINES FULLY INSTALLED.

and expense of excavation and leveling, the floor level was divided into three sections, with a drop of 4 ft. between each. The floor levels are connected by ramps or sloping alleyways 5 ft. 6 in. wide with a slope of 1 in 5.

The entire framework of the building is of structural steel, the type of construction being illustrated by the cross-sectional drawing of the building. In all, 266 built-up columns were necessary. The floors were of 3 in. timbering nailed to 10 x 4 in. timbers supported by 18 x 7 in. rolled steel joists, which extend across the building. Brackets and fastenings for countershaft beams, motor platforms, and shafting hangers were incorporated in the column design and fabricated with them at the structural yards. The roof covering is of inch boarding nailed to wooden purlins and covered with fibro-cement slates. Continuous glazing is introduced on the north side of the three bays of the roof, while swinging ventilators are fitted also.

Rapid Construction

In less than eight weeks from the date of signing the contract, the whole of the steel work for the main building amounting to 1,320 tons, was delivered and erected, while less than ten weeks saw the first machine tool under power. The tool room, as a department was actually running within three months from the start of operations. Some idea of the extent of the operations carried out in a little more than three months is given by the fact that the building involved the rolling of 6 1/4 miles of one section of channel steel. There are 248 side windows and 1,350 ft. run of roof windows, the number of panes of glass being 9,500, covering an area of three-quarters of an acre.

In the equipment of the shops with machine tools, etc., equally expeditious work was achieved. The compact arrangement of tools, benches, offices,

portion of the main building to which it connects, the remainder of the annex being 4 ft. lower and connected with sloping runway as described.

Department Layout

The higher level of the main building and of the annex is used as a grinding shop, where vertical, cylindrical, and surface grinders are installed. The remainder of the annex is given up to millers and lathes for small tool work, while at the extreme end is built a hardening

The factory is entirely electrically driven, the system being that of using an overhead central platform for taking the motors, which was introduced some ten year ago by this section of the Vickers factories. In this instance the system has been pushed a step further; high-tension current is brought into the building at 3,000 volts from the company's power station on the river bank, which is some distance away, and converted by means of Vickers rotary converters, which are placed at one end of the platform on the ground floor, into 210-volt

Driving System

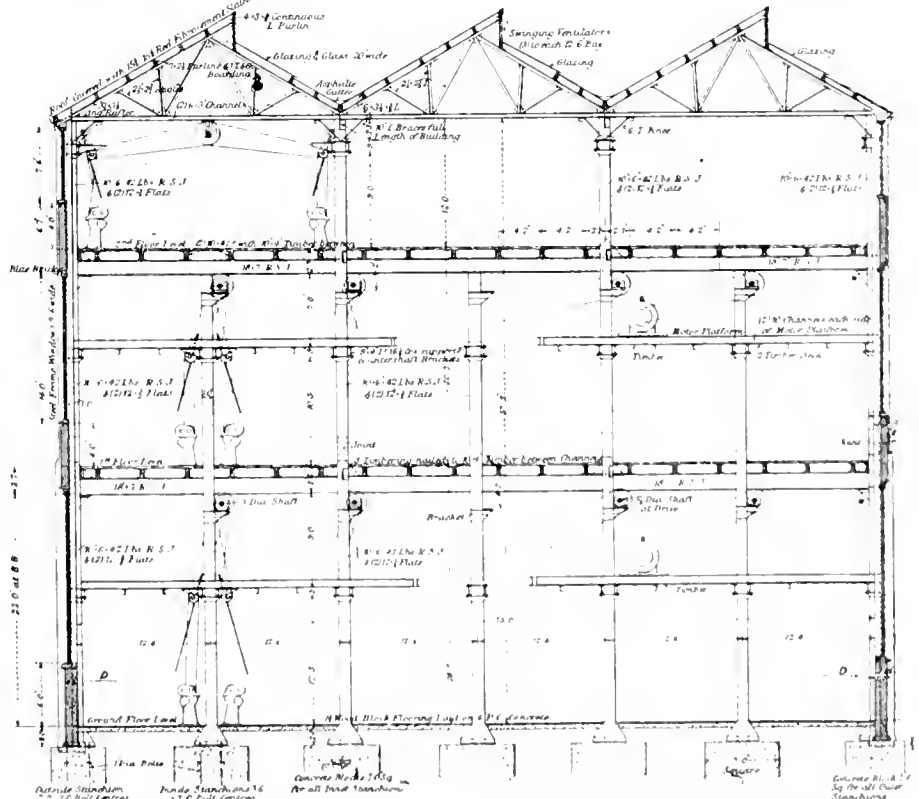

CROSS SECTION OF MAIN BUILDING, SHOWING ARRANGEMENT OF FLOORS, MOTOR DRIVES AND SHAFTING DISPOSITION

direct-current. The controlling switch-board is placed on the motor platform of the ground floor, and direct-current conductors are led direct from the switch-

Starting Operations

Equally interesting was the provision made for getting the shop under way as soon as the tools could be installed. This



BLOCK OF 120 AUTOMATIC MILLING MACHINES.

board to the motors on the platform, thus reducing the direct-current wiring to a minimum. This system has the advantage of having the whole of the motors driving the line shafting centralized and under easy observation of the attendant. The electric motors are by the Electric and Ordnance Accessories Company — a subsidiary company of Vickers, Limited — and are placed on each side of the motor platforms; they drive by belts and pulleys, as indicated on the cross-section direct to the line shafting.

The line shafting runs in "Cooper" roller bearings supported on brackets riveted to the main columns of the building. Countershaft girders are arranged midway between the machine drive and the main shaft, and the countershafts are supported by special brackets secured to the countershaft girders by hook bolts. All the fittings in connection with rigging up the countershafts are standardized, and any countershaft with the hangers supplied by the machine tool makers can be fitted up without the millwright having to drill a single hole.

The machine tools are of the lighter, accurate variety, and nearly every well-known machine tool maker, producing the type of machinery required, of England and America, is represented, careful consideration having been given to get machines best adapted to the work. In laying out the shop, however, the greatest number of machines of one type have been purchased in order to reduce spare parts.

The building is heated throughout by unit steam heaters with electrically driven fans. The top of each unit is connected by means of ducts with the outside atmosphere, so that the shop floor can be flooded with cool air in summer, or by circulating warm air in winter.

required great foresight, because female labor was to be used to the maximum extent. As a consequence considerable modification in the designs of jigs and fixings had to be made, with the object of simplifying the machining operations. Again, as it was impossible to obtain tool designers and tool makers, a number of the better educated apprentices at the works were drafted on to the re-designing of the methods of manufacture. A section of the old machine gun department was therefore allocated to the manufacture of the jigs and fixings thus designed for the new shop where female labor was to be employed. Where possible, the assistance of tool-making firms was also obtained in order to duplicate gauges and receivers to meet the additional inspection requirements for the testing of interchangeability of the gun component parts. Thus, as soon as part of the building was roofed in the top floor was taken possession of in order to instal the suitable machinery available for use exclusively on tool-making.

To begin with it was decided to concentrate machine work in the new shop on the controlling details of the gun; leaving the other details to be provided by the old shops, while at the same time work was continued to complete the whole range of tools, jigs, gauges, receivers, etc. As the new building developed the manufacture of the remaining units of the gun was added to the original machine operations in the new shop the whole of the machining in this new factory being carried out by women labor. This arrangement achieved a regular growing output without overlap and a minimum expenditure on gauges, receivers, and tools, and conduced also to specializing in the output of certain details in each department, with a conse-

quent rapid production and economy in machine setting.

It is not permissible to indicate the volume of output, but from the foregoing it will be accepted that this new factory — one of many which have been erected since the beginning of the war — once more establishes the enterprise, energy and resource of British engineering. The building is a thoroughly substantial one, and will stand long after the war is over. The machine tools within it are of highly specialized design to undertake specific operations with the exercise of the least measure of intelligence on the part of the operator. There is ensured economy in man-power, extreme accuracy — to one-thousandth part of an inch — and absolute interchangeability. Whether, when the war is over, these tools can be utilized with the same degree of efficiency for peace productions remains to be seen; but it would be a striking reversal of the policy which has enabled such highly efficient factories to be equipped for war work, if, in peace time, the same machine tools, if used for unsuitable work, failed because unsuited in design to achieve corresponding efficiency. However suitable a building, the machine tools used in future for engineering productions must, in practically all cases, be of highly specialized design. This result must be attained even at the cost of discarding otherwise suitable appliances. There can be labor substitution, but not indiscriminate utilization of any type of machine tool for special machining operations.

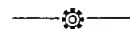

RECOVERY OF A WRECKED SUBMARINE

THE recovery of a wrecked enemy submarine by the Italian Government in the Adriatic, and its successful repair and entry into the service of the Italian navy, has been accompanied by the publication of much interesting information concerning the doings of the craft, its origin and subsequent journey overland, etc., all of which facts in the light of past events, are conclusive proof, if any were required, of treacherous conduct on the part of Germany toward Italy when their relations were still nominally on a friendly basis. The captured log book gives full particulars of her ill-fated career and other documents establish the fact that she was a unit of the German navy, manned by a purely German crew, and was engaged in active hostilities against Italy many months before that country declared war on Germany.

The UC-12 was a small submarine specially designed for laying mines. Her surface displacement is 190 tons, and when submerged is 210 tons. The approximate length is 110 ft., with a maximum diameter of 10 feet. A four-cylinder Diesel engine of 90 horse-power was installed, giving a surface speed of six knots, and a submerged speed of four knots. Six wells in the fore part of the vessel enabled twelve mines to be carried, these being released by a control in the conning tower.

The following report of the activity of



SHOWING EFFECT OF EXPLOSION ON MIDSHIPS SECTION OF HULL.

the UC-12 while in enemy hands has been published by *The Engineer*, the successful conclusion of salvage operations by the Italian authorities being noted with pleasure.

The UC-12, according to her log-book, was one of the first two mine-laying submarines which Germany placed at the disposal of Austria-Hungary for the war against Italy. She was built at the Weser yard, Bremen, all her internal fittings being stamped with the name of Siemens-Schuckert. The launch took place at the beginning of May, 1915, and a few days later the boat proceeded through the Kaiser Wilhelm Canal to Kiel, where she arrived on the 17th, and at once embarked a cargo of mines. A month later, i.e., after Italy's declaration of war on Austria, she was dismantled, divided into four sections, and placed on a train, arriving at Pola on June 24, with her crew and commander. Here she was reassembled in four days, and again took to the water, intact as at first, and, as the Italian Government observes, "Ger-

bons of the crew with the three letters B. A. K.—Bekleidungs- Abteilung, Kiel

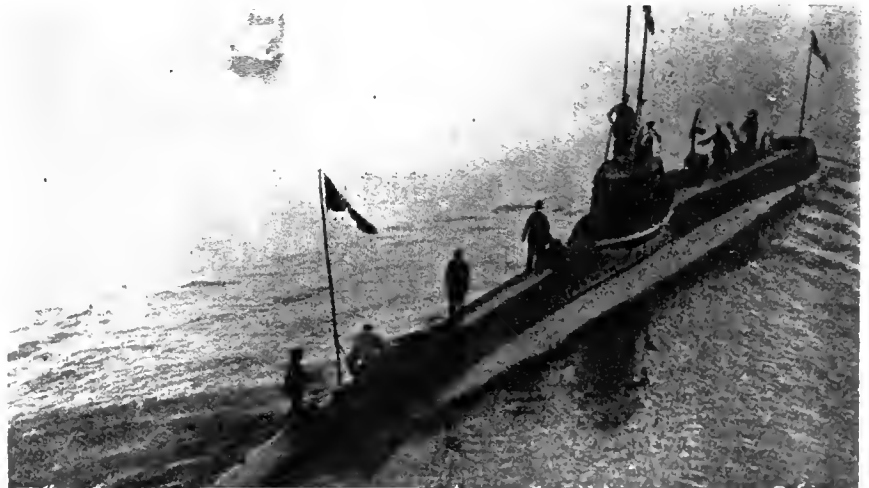

THE UC-12 AFLOAT AND IN SERVICE OF THE ITALIAN NAVY.

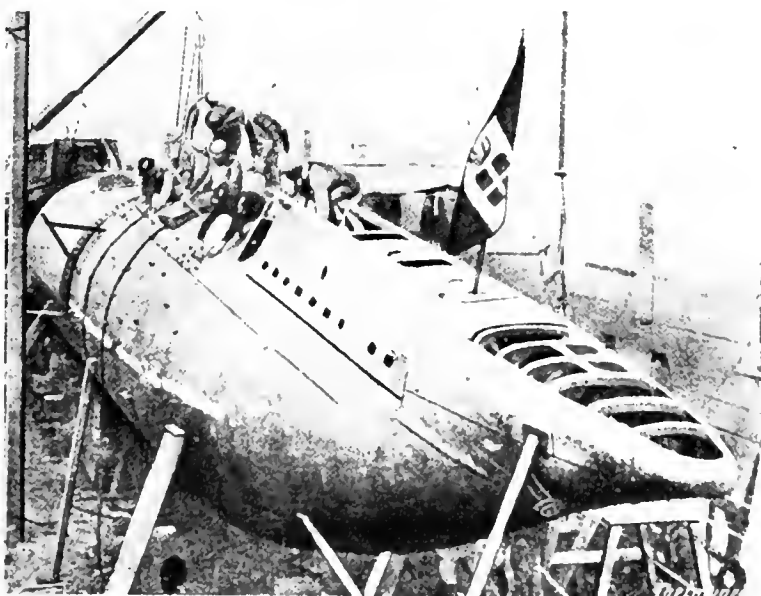

RECONSTRUCTED HULL APPROACHING COMPLETION IN DRYDOCK.

man in everything, from the imprint 'Kaiserliche Marine' on every chart to the German Imperial crown ornamenting the table service, and from the cap rib-

—to the numerous Iron Crosses found in her interior." On July 25 and August 15, she visited the neighborhood of an Italian naval base, and there laid two

barriers of mines. In the following December she was at Cattaro, taking on board a cargo of rifles and ammunition, destined for the rebellious Arabs in Lybia. These were duly landed at Baria, near Sollum, on the coast of Cyrenaica, after which she returned to the Adriatic.

At the period when there was an abnormal amount of traffic between the two shores of the Adriatic in connection with the transport of the Serbian army, its impedimenta and prisoners — an enterprise which, by the way, was carried out without the loss of a single ship—the UC-12 was cruising off Durazzo, and distributing mines liberally in the roadstead. None of these, however, claimed a victim. After this vain attempt she paid another visit to Cattaro, and then lurked about for three days at the entrance to the Italian base where she had first put in an appearance. Here, it seems, she fouled one of her own mines

or blundered into those which had been laid for the defence of the port. At all events, a dull explosion was heard, followed by an immense column of water, and the patrol vessels at once arrived to investigate the phenomenon. Divers who were sent down came upon the wreck of the submarine at a depth of nearly 100 feet. The explosion had blown her practically in two. The extremities were not much injured, but amidships the havoc was very great, as will be seen by the illustration herewith. The bodies of fourteen of the crew were found. Fragments of uniforms were discovered, together with badges, cap ribbons, and other articles, which left no doubt as to the identity of the boat and her crew. A machine gun was also recovered practically intact. The cap ribbons bore such devices as "S.M.S. Vulkan," "S.M.S. Streit," "S.M. Unterseeboot VI.," "2 Minen-Abteilung," etc.

At first sight the wreckage seemed too complete to admit of salvage, but a closer survey convinced the Italian naval engineers that the reconstruction of the boat would offer no insuperable difficulties. The wreck was accordingly raised, in itself a task of no mean order, considering the great depth of the water, and placed on a slip for repair. The mil-

ship section, which had caught the full force of the explosion, had to be entirely rebuilt, while at the bow and stern new plates were fitted, the hydroplanes and rudders replaced and the shafting repaired. It is to be presumed that the original propelling machinery was hopelessly damaged, but on this point there is no definite information. Throughout the work special care seems to have been taken to preserve the characteristic features of the design. What remained of the coming tower was skilfully repaired, and such fittings as were still serviceable were restored. The task was finally completed, and it will be readily conceded that the result, as depicted in our engraving, reflects great credit on all concerned in the work. The UC-12 is now serving as a unit of the Italian navy, thought doubtless under a new name and one less suggestive of her Teutonic origin. It is interesting to note that, according to an official Rome communique of Jan. 13, another enemy submarine, the U-12, was sunk, and has since been salvaged and placed in commission. This appears to be one of the large German-built ocean-going submarines of 1,000 tons displacement, which had been ordered by the Austrian Government in 1912, and were due to be delivered in 1915. So far as the smaller UC-12 is concerned, the Italian naval authorities are to be congratulated on the highly successful completion of a piece of salvage and repair work which obviously called for no ordinary degree of patience and technical skill.

ORIGIN OF TONNAGE MEASUREMENT SYSTEMS

THE present system of tonnage measurement, known as the Moorsom system, became law in 1854, and, though subsequently amended in detail, remains to this day the basis for the computation of tonnage in all the principal nations of the world.

According to Sir George Holmes, who is quoted by *Syren and Shipping* in the matter, an Act was passed in 1694 for measuring the tonnage of English merchant ships which contained the following rule:

$$\text{Tonnage} = \frac{L \times B \times D}{94}$$

When L = length of keel (so much as she treads on the ground).

B = breadth amidships from plank to plank, in board.

D = depth of hold, as before.

This formula was supposed to give the deadweight carrying capacity of the vessel. The product $L \times B \times D$ expressed, of course, the parallelepipedon of which the sides were the length of keel, the breadth in-board from plank to plank, and the depth of hold, and the divisor 94 meant that every 94 cub. ft. of this parallelepipedon was to be reckoned as one ton. As the true internal volume of the vessel would not exceed six-tenths of that of the parallelepipedon, it is evident that about $(94 \times .6) \doteq 56.4$ cub. ft. was reckoned as a ton, and this figure approximated fairly to the value in the

time of Henry V. An Injurious Act. The Act of 1694 was repeated two years later, and in 1720 another was passed which substituted the half-breadth for the depth of hold. Probably no Act has ever done more injury to naval architecture than the tonnage law of 1720. The half-breadth no doubt represented at the time very approximately the depth of hold; but the law offered a direct inducement to shipbuilders to augment the carrying power of their vessels, without altering the legal tonnage, by the simple expedient of increasing the depth while making no corresponding increase in the breadth, and thus a class of short, narrow, deep and utterly unseaworthy vessels came into existence.

The celebrated Tonnage Act of 1773, which remained in legal force for 62 years, and was still in use in the Royal Navy till as lately as 1872, perpetuated, Sir George goes on to say, the same error. The tonnage, as measured under this Act, was called "Builders' Old Measurement Tonnage." The length for tonnage was measured along the rabbet of the keel, from the back of the sternpost to a perpendicular dropped from the fore part of the main stern under the bowsprit. From the length thus obtained, a deduction equal to three-fifths of the breadth (measured as explained farther on) was allowed, and the difference was called the length for tonnage. If the vessel were afloat at the time of measurement, instead of taking the length along the keel, the length of waterline, or of deck was ascertained, and an allowance made by way of reduction of 3 in. for every foot of draught. This allowance was to compensate for the rake of the sternpost, and was independent of the deduction of three-fifths of the breadth.

The breadth was measured outside the planking at the widest part of the ship, but the thickness of any doubling strakes was not included. Half of this breadth was taken instead of the depth. Subject to these allowances and differences in the mode of measurement the B.O.M. tonnage law was identical with that of 1720, the divisor 94 having still been used.

Later Development

Between 1836 and 1854, what is known as the "New Measurement" system was in force. The object of it was to obtain a more accurate computation of the cubic contents of those parts of a vessel available for stowage, underneath the permanent decks. The depth was restored as an element in the calculation, but the various lengths, depths and beams were to be measured at a *very few fixed positions*, and this peculiarity of the Act offered owners many opportunities of evading the intention of the law. It is said that in some cases ships built under this Act had a volume of about one-sixth greater than their nominal capacity. The factor of division was 92.4 instead of 94, and in the case of steamships the volume of the space between the engine-room bulkheads was allowed as a deduction from the gross tonnage. The general effect of the Act was to do away with the premium which previous legislation had offered to the building of short, nar-

row, deep ships; but on account of the many opportunities which it offered for evasion, it was eventually superseded by the Moorsom system of measurement.

CANADA'S TRADE STATISTICS

THE total trade of Canada for the four months of the year, leaving aside the gold figures and exports of foreign produce, was 683 millions, against 499 millions in the corresponding period of 1916, and only 276 millions in the corresponding period of 1915, increases of approximately 40 per cent. and 155 per cent. respectively. But of the gain of 184 millions, as compared with 1916, 115 millions fell under the head of imports, against a 69-million gain in exports.

"National revenues naturally continue buoyant under the large expansion in imports, customs collections in April, for instance, being \$13,875,485, against \$9,797,365 in April, 1916," says the *Journal of Commerce*, Montreal, "but our interest obligations have increased with heavy outlays for war expenditure, and the main dependence for keeping the position steady, while the inflow of new capital for development is checked, rests in establishing and holding a favorable trade balance—in selling abroad a good deal more than we buy."

BRUSH-HOLDERS FOR SLIP RINGS

BRUSH-HOLDERS for metal graphite brushes take forms both foreign and akin to direct-current holders. With these holders the brushes require the usual multiplicity of expensive shunts, the necessity for which, with a proper holder, is at least debatable. Inasmuch as slip ring brushes may be placed indiscriminately around the rings, there is no occasion for maintaining a fixed brush relation to the rings. The ideal holder, therefore, may be in the development of the swivel type, in which the brush may be clamped in the box and the brush itself requires no shunt. The box should, however, be heavily shunted to the holder support in order to protect the swivel from possible arcing due to the current passing through the swivel joints. The brush will require occasional readjusting in the holder due to the wear of the brush reaching, from time to time, the travel limit of swivel. (This limit should not permit the holder to come in contact with the ring). This requirement, however, will not approach the work involved in trimming copper leaf brushes, or in cleaning the accumulated dust from between the brushes and holders, as is necessary with present holders.

At the present time a few slip ring motors are being fitted with a holder of the foregoing type, but the value of its general application has not been fully determined. Present holders are designed to take single brushes, or two brushes side by side, or two brushes in "tandem." The last-named holder is the least desirable for the reason previously stated. However, it has the advantage of economizing the space around the ring and to a degree precluding congestion. Its single objection can be readily overcome by using a partition between the brushes.

PROGRESS IN NEW EQUIPMENT

A Record of New and Improved Machinery and Accessories for the Machine, Pattern, Boiler and Blacksmith Shops, Planing Mill, Foundry and Power Plant

UNIVERSAL ANGLE PLATE

THE efficiency of the modern machine shop is such that the confidence of designers in the ability of most plants to produce work efficiently causes them to frequently arrange parts so that angular connections and surfaces are introduced which formerly would be studiously avoided. Many automobile parts, as well as jigs and fixture construction call for work of this nature and the device illustrated in the accompanying engravings has been developed to meet just such conditions.

The Universal angle plate consists of a semi-cylindrical casting provided with tee slots on its flat side which is the work surface. The cylindrical surface fits accurately into an angle bracket, being tongued and grooved and locked in position by two tee slots as shown. The angle bracket is arranged to swivel on a base plate which in turn is bolted to the machine table. By this arrangement work secured in position may be revolved through 360 deg. horizontally

and 90 deg. vertically. The plate can be accurately graduated with Vernier attachment permit readings to 5 min., and make it suitable for fine work. The device is built by the Boston Scale &

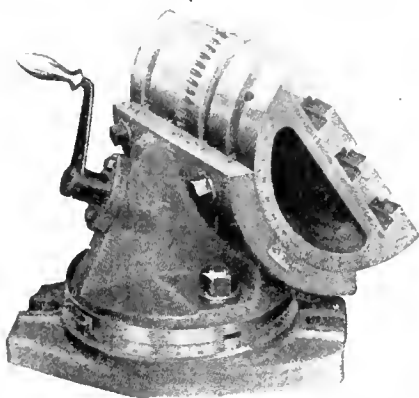

UNIVERSAL ANGLE PLATE WITH WORM ADJUSTING GEAR.

Machine Co., Boston, Mass., in four sizes, from 4 x 6 in. weighing 16 lbs. to 12 x 18 in. weighing 425 lbs. The two largest sizes have worm adjustment as shown in illustration.



HIGH SPEED BALL BEARING SENSITIVE DRILL

A HIGH speed ball bearing drilling machine with spindle speed up to 12,000 rev. per min., is now being manufactured by the De Mooy Machine Co., Cleveland, O. It is built in both bench and floor types, the latter being shown in the accompanying engraving. The high speed obtainable enables twist drills of 3/16 in. dia. and under to be operated under conditions which enable them to cut their way through material instead of being forced, as is frequently the case when run too slowly.

High grade annular ball bearings combined with properly balanced parts reduce vibration to a minimum. The spindle is 7/16 in. dia., and is of high carbon steel, heat treated. It has a spring counterbalance. Three speeds are provided, the belt cone diameters being 3, 4 1/2, and 6 in.

The idler bracket has spring take-up for maintaining constant equal tension in belt, the bracket being controlled by a rack and sector with lever, so that the belt may be instantly slackened to allow of quick speed changes. A flat, endless canvas belt possesses ample flexibility for use at the high speed employed.

A three-jawed, geared-nut chuck of the key type is fitted to spindle. The principal dimensions are: Spindle centre to column, 7 1/2 in.; vertical movement of spindle, 4 in.; ditto, table, 7 in.; ditto, table arm, 25 in.; working surface, table, 12 1/2 in. dia.; weight, 200 lbs.; height, 65 in.

THREAD MILLING FIXTURE FOR SHELLS

A FIXTURE for producing threads on shrapnel and other shells is being manufactured by the Hall Gas Engine Co., Inc., Bridesburg, Philadelphia. It is designed for attachment to a lathe or milling machine and can be employed for producing either internal or external threads on brass, aluminum, steel or other metals. In addition to being used for munitions work, the fixture is adapted for automobile, firearms, talking machine, and similar plants producing interchangeable parts. Minute accuracy of adjustment for diameter and lead is claimed, as well as elimination of loose joints and provision to insure sufficient lubrication and protection against the entrance of dust.

The fixture is used in connection with a cutter having several parallel rows of teeth so that a single revolution of the work is sufficient to finish the thread.

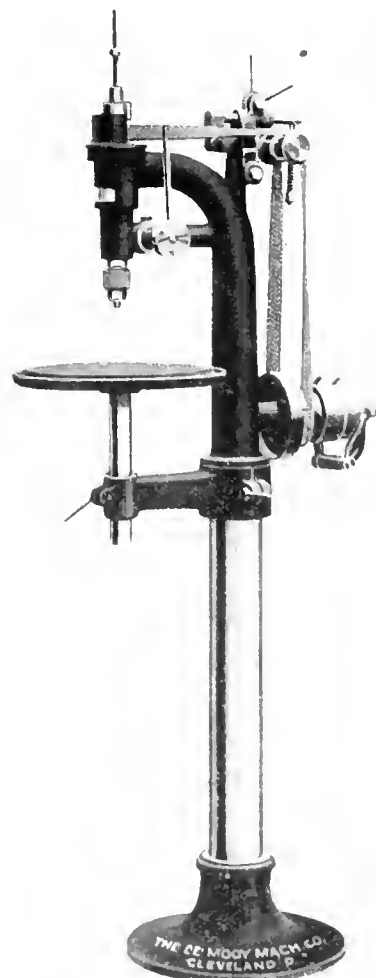

HIGH SPEED BALL BEARING SENSITIVE DRILL.

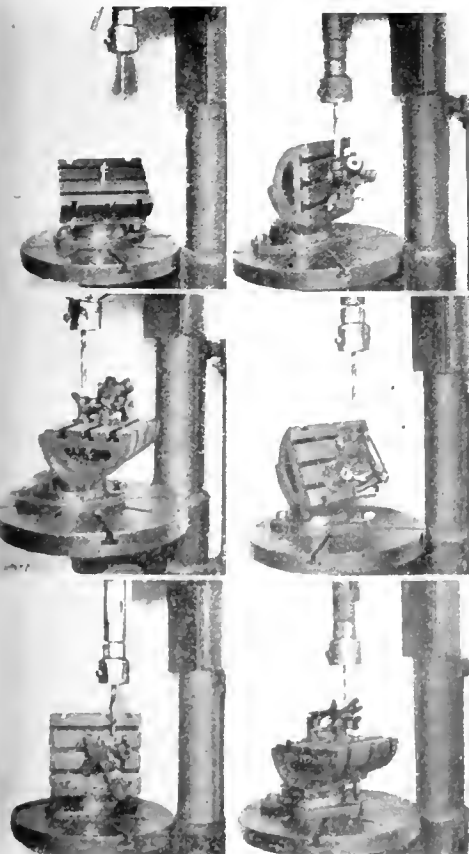

APPLICATION OF UNIVERSAL ANGLE PLATE TO DRILL PRESS WORK

be quickly adjusted to any angle without disturbing work bolted to it, the surface of the work table intersecting the horizontal axis of its rotation.

The work to be threaded is held in a collet at the left of the fixture which is revolved by a sleeve upon which the lead screw is cut. The elimination of loose

graphite, shaped under pressure. When metal graphite brushes were first introduced their carrying capacities were greatly over-estimated. Manufacturers

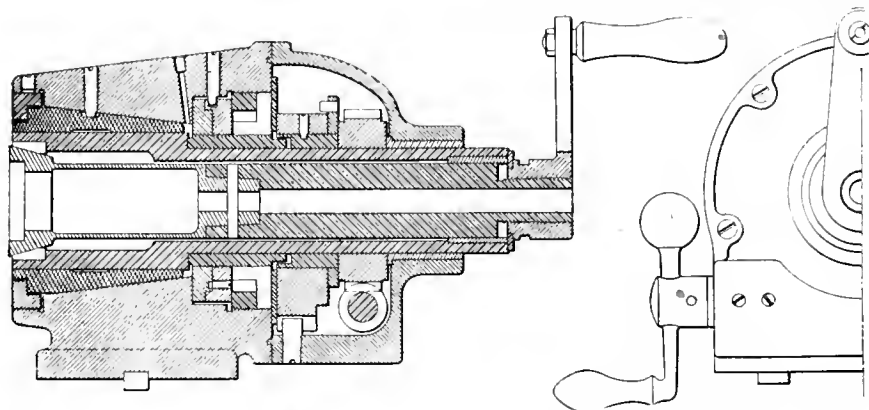

WORK TO BE THREADED IS MOUNTED IN COLLET AT LEFT, WHICH IS REVOLVED BY A SLEEVE UPON WHICH THE LEAD SCREW IS CUT.

joints and other sources of inaccuracy is claimed to reduce the error between the lead screw and the nut to less than .0001 in.



ELECTRIC GRINDING MOTOR

IN an effort to meet the demand for machines of this type, the U.S. Electrical Mfg. Co., Los Angeles, Cal., has brought out the electric grinding and buffing motor illustrated in the accompanying engraving. While essentially a low priced tool, it possesses pleasing appearance combined with smooth running and silent operation.

The spindle is carried in ball bearings mounted in special housings with sealing rings that one proof against dirt and grit. The ball bearings are of standard dimensions and easily replaced in the event of wear. The spindle is of heavy one piece construction while the motor as a whole is entirely enclosed. Tool rests, adjustable in any direction, are provided for each wheel; wheel flanges are of ample size and turned all over. Heavy guards are fitted to each wheel and a water pot is supplied which swings under the table out of the way when required.

This tool is furnished either as motor only for bench mounting—motor with pedestal—or motor with pedestal and complete equipment as shown.

Spindle speeds are 1800 and 3,600 rev. per min., and powers are $\frac{1}{2}$ and 1 horse power with 110 and 220 volt single phase current, and $\frac{1}{2}$, 1 and 2 horse power with 110, 220 and 440 volt, 2 and 3 phase current. Guards take wheels up to 10 in. x $1\frac{1}{2}$ in., length of spindle overall, 25 in., dia. of arbor, at wheels, $\frac{3}{4}$ in.



BRUSHES FOR SLIP RINGS

THE copper leaf brush for slip rings, which has been in favor since the days of incipient machines, is fast giving way to "block" or "metal graphite" brushes. Generally speaking, metal graphite brushes consist of various mixings of pulverized copper and other metals with

of electrical apparatus dropped into the error of using too few brushes, and in many instances found it necessary to increase the slip ring brush equipment as much as 50 per cent. before satisfactory results could be obtained in the field. At the present time the maximum permissible current is considerably below 150 amperes per square inch, while the safe

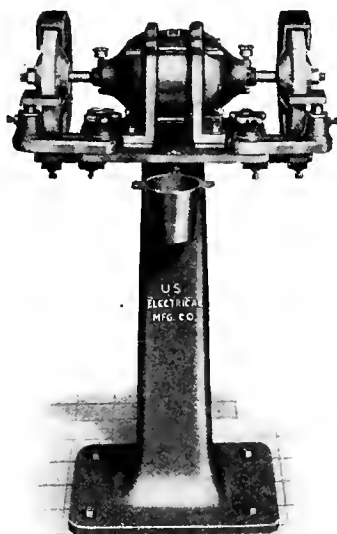

ELECTRIC GRINDING AND BUFFING MOTOR.

limit is perhaps under 125 amperes per square inch. This type of brush is also used on direct-current machines of very low voltages. Its metallic characteristics, however, are at times hard on the commutators.

As a rule, the more highly graphitized brushes have proven the more satisfactory in that they have a longer life and cut the rings less. It is contended that these brushes are self-lubricating, and to a degree this is true. However, if the rings on which they run are kept free from copper dust, and a slight amount of lubrication (light oil) is judiciously applied, the life of both brushes and rings will in most cases be prolonged. This type of brush is extremely heavy and re-

quires a brushholder of decided stability, with springs capable of pressures as high as five or more pounds per square inch. The actual pressure to be used is determined by the type of ring, speed of ring, and composition of the brush. It is, however, rarely less than three and one-half pounds per square inch, and more frequently five. When brushes of this type are allowed to spark they disintegrate rapidly and the life is greatly shortened.

In case the brush is not sufficiently granular in texture it will "roll up" or "fringe" or form "wire edges" on the sides. Obviously, such brushes are dangerous, for the reason that such edges frequently break away from the brush in full contact length, bridge to, or fall across, rings having different polarities, and flash the machine. To guard against this the brush should be slotted radially with a file, two slots to a side "V" shaped, and about one-eighth of an inch in depth. Under this condition the maximum possible length of thrown-off metal will be something less than one-third of the arc of the brush contact. This is too short to bridge or cause damage. Although a brush may be in every other way satisfactory, if it has this "fringing" characteristic it is not desirable.

Application of Slip Ring Brushes

All types of slip ring brushes should be installed so as to cover the full width of the ring, but never so as to permit the brush to overhang the ring. This is easily accomplished by properly "staggering" the brushes, all slip ring brushholders being designed for this adjustment. Metal graphite or "block" brushes are generally installed radially, and with either one or two brushes in each holder. When two brushes occupy the same holder they should be placed side by side—not in "tandem." If in "tandem," the leading brush is packed against the leading face of the holder by the lagging brush, due to the rotation resultant, and the brushes do not wear uniformly. It may be possible to overcome this by changing the brush angle, or by a change in the resultants of spring pressures. As previously stated, the pressure should be from three to five pounds per square inch.



The conductor was about to give the motorman two bells to go ahead.

"Wait!" shouted an unmistakably feminine voice, "wait till I get my clothes on."

Whereupon seven men rubbered to see a fat woman lift her basket of laundry aboard the car.

* * *

The soldier on the train was dilating on his changed life. "They took me from my home," he said, "and put me in barracks; they took away my clothes and put me in khaki; they took away my name and made me 'No. 575'; they took me to church, where I'd never been before, and they made me listen to a sermon for 40 minutes. Then the parson said, 'No. 575, art thou weary, art thou languid?' and I got seven days C.B. for shouting 'Not a dam bit.'"

The MacLean Publishing Company

LIMITED

(ESTABLISHED 1888)

JOHN BAYNE MACLEAN - - - - - President
H. T. HUNTER - - - - - Vice-President
H. V. TYRRELL - - - - - General Manager

PUBLISHERS OF

CANADIAN MACHINERY AND MANUFACTURING NEWS

A weekly newspaper devoted to the machinery and manufacturing interests.

PETER BAIN, M.E., Editor. B. G. NEWTON, Manager.

Associate Editors

A. G. WEBSTER J. M. WILSON J. H. RODGERS

Office of Publication, 143-153 University Avenue, Toronto, Ont.

Vol. XVII. JUNE 14, 1917 No. 24

MORE PUBLICITY CONCERNING OUR SHIPBUILDING EFFORT

IT is highly significant that little, if any, disposition is being shown by Canada's shipbuilding and shipping executives to take part in the daily press controversy relative to what this Dominion can or should do to help offset the meantime ship shortage emergency. That a full appreciation of all the circumstances is theirs, little doubt may be entertained, therefore, silence on their part seems golden. In the House of Commons, Ottawa, on June 1, the Hon. J. D. Hazen, in his replies to a number of queries concerning shipbuilding within our borders, gave some specific instances of the activity prevailing as regards both wood and steel construction. As was to be expected, however, the information imparted was in no sense satisfying to the exponents of the one-ship-a-day policy so firmly believed in and fondly cherished by the craft non-descripts.

Canada is doing a good deal more in the realms of shipbuilding and marine engineering than the Minister of Marine and Fisheries made public, although doubtless his immediate audience knew that such was the case and were more or less familiar with the complete detail. To continue to withhold information, however, as to the full scope of our shipyard and engine-works activities is, it seems to us, causing unnecessary apprehension on the part of our citizens generally that a capacity output is not being realized, besides tending to reflect on and in turn irritate those charged with the administration of our various plants. The restraint put upon the publication of our munitions activities when first undertaken was of brief duration, yet while the privileges later afforded were wide in scope and might easily have been abused, no awkward situations developed; rather did the publicity feature become of material benefit, stimulating as it did both effort and its result value.

Our ship and engine builders are not only working to the capacity of their plants at the present time, but their showing as regards progress and output is equally satisfactory with that of munitions. The reserve being shown

relative to plant establishment or to schemes of enlargement is logical, in view of the fact that in half a decade or even less, following the Peace Declaration, our position will be world competitive in shipbuilding, an eventuality not lightly to be overlooked. Present conditions are entirely abnormal, and to cope with same without consulting the future as some would have us do, is to ensure that much of the capacity for the abnormal would speedily become grass-grown later. We'll never be a shipbuilding nation worth-while, until we can produce the steel in its variety type and form for vessel, engine and boiler construction requirements, which leads us to say that our first duty, because it is our biggest need, is the planning and initiation of enterprise in that direction.

As it is, we are under the necessity of importing practically everything that enters into steel vessel construction, and same is true to about the same extent as regards equipment, propelling and auxiliary machinery. The delays in receipt of material are equally abnormal with the times, nor are such circumstances to be wondered at when account is taken of the fact that the United States, on whom we depend so largely for the requisite supplies has a shipbuilding programme of prodigious dimensions of its own on hand, and may readily lay claim to first call on its steel mills, blast furnaces, forges and coal mines.

With a view to allaying the misgivings and unrest arising from the lack of public knowledge as to what Canadian ship and engine builders are doing to help eliminate the shipping emergency, we suggest that permission be granted them to furnish authoritative data for publication, subject, of course, to somewhat similar and equally reasonable restrictions as have been operative in our munitions industry.

PRESENT INFLUENCES ON MACHINE TOOL ACTIVITY

SHIPBUILDING, no less than shell making, is destined to influence the tool industry of Canada. There is this difference, however. In munitions manufacture the demand for tools was so insistent and imperative that neither designs nor resources were immediately available for the production of other than standard type tools. Months passed before the combined effort and consideration of producers resulted in the flow of those special purpose machines which have changed the whole aspect of quantity machine work.

It is not expecting too much, to hope that a similar development, more rapid and timely, will occur in connection with shipyard and engine shop equipment. Many firms engaging in these lines are untrammelled by tradition or precedent, and, provided that the requisite quality of workmanship be maintained, the freer perspective enjoyed by these concerns, coupled with the example of the munitions industry, should result in innovations of considerable calculable benefit to both machine tool builders and shipbuilders.

The demands of the situation prompt the suggestion that well designed tools of the heavy portable type will prove of considerable value. By moving them around to work in various locations, the necessity for extensive handling plant will to a great extent be avoided, while their adaptability to operations of more diverse character, with greater facility than permanently located tools of stereotyped design should result in their adoption by those plants whose activity in this work is more or less temporary. Several suitable designs have been marketed during recent years, but if history repeats itself, a good deal of development in this direction is due to take place.

SELECTED MARKET QUOTATIONS

Being a record of prices current on raw and finished material entering into the manufacture of mechanical and general engineering products.

FIG IRON.

Grey forge, Pittsburgh.....	\$43 95
Lake Superior, charcoal, Chicago.....	50 00
Standard low phos., Philadelphia.....	75 00
Bessemer, Pittsburgh.....	50 95
Basic, Valley furnace.....	45 00
Montreal Toronto	
Hamilton.....	
Victoria.....	

FINISHED IRON AND STEEL.

Per lb. to Large Buyers Cents	
Iron bars, base, Toronto.....	5 00
Steel bars, base, Toronto.....	5 25
Steel bars, 2 in. to 4 in. base.....	6 00
Steel bars, 4 in. and larger base.....	7 00
iron bars, base, Montreal ..	4 75
Steel bars, base, Montreal ..	5 00
Reinforcing bars, base.....	5 25
Steel hoops.....	7 00
Bessemer rails, heavy, at mill.....	38 00
Steel bars, Pittsburgh.....	4 25
Tank plates, Pittsburgh.....	7 00
Structural shapes, Pittsburgh.....	4 25
Steel hoops, Pittsburgh.....	4 25
F.O.B. Toronto Warehouse.	
Steel bars.....	5 00
Small shapes.....	3 50
F.O.B. Chicago Warehouse	
Steel bars.....	5 00
Structural shapes.....	5 00
Plates.....	8 50

FREIGHT RATES.

Pittsburgh to Following Points	
Per 100 lbs.	
C.L. L.C.I.	
Montreal.....	23.1 31.5
St. John, N.B.....	35.1 45.5
Hullfax.....	35.1 45.5
Toronto.....	18.9 22.1
Quepb.....	18.9 22.1
London.....	18.9 22.1
Windsor.....	18.9 22.1
Winnipeg.....	64.9 85.1

METALS.

Montreal Toronto	
Lake copper.....	\$38 50 \$37 00
Electro copper.....	38 50 37 00
Castings, copper.....	37 50 36 00
Tin.....	62 50 66 00
Spelter.....	13 50 12 00
Lead.....	14 00 14 25
Antimony.....	25 00 26 00
Aluminum.....	70 00 68 00

Prices per 100 lbs.

PLATES.

Montreal Toronto	
Plates, 1/4 to 1/2.....	\$10 00 \$10 00
Heads.....	10 30 10 30
Tank plates, 3-16 in. 10 10 10 10	

WROUGHT PIPE.

Effective May 14, 1917.	
Black Galvanized	
Standard Butt weld.	
Size.	Per 100 feet
1/8 in.....	\$ 4 50 \$ 6 00
1/4 in.....	4 96 7 00
3/8 in.....	4 96 7 00
1/2 in.....	6 29 7 86
3/4 in.....	7 94 10 06
1 in.....	11 73 14 88
1 1/4 in.....	15 87 20 13
1 1/2 in.....	18 98 24 06
2 in.....	25 53 32 38
2 1/2 in.....	40 95 51 77
3 in.....	53 55 67 70
3 1/2 in.....	66 24 83 26
4 in.....	78 48 98 65
Standard Lap weld.	
2 in.....	28 49 34 97
2 1/2 in.....	42 71 52 94
3 in.....	55 85 69 23

3 1/2 in.....	68 08	86 02
4 in.....	80 66	101 90
4 1/2 in.....	93 98	118 70
5 in.....	109 50	138 40
6 in.....	142 10	179 50
7 in.....	185 60	232 05
8 L in.....	195 00	243 75
8 in.....	224 60	280 80
9 in.....	269 10	336 38
10 L in.....	249 60	312 00
10 in.....	321 40	401 70

Prices—Ontario, Quebec and Maritime Provinces.

WROUGHT NIPPLES.

4" and under, 50%.	
4 1/2" and larger, 45%.	
4" and under, running thread, 30%.	
Standard couplings, 4" and under, 40%.	
4 1/2" and larger, 20%.	

OLD MATERIAL.

Dealers' Buying Prices.	
Montreal Toronto	
Copper, light.....	\$22 00 \$22 00
Copper, crucible.....	26 00 27 00
Copper, heavy.....	26 00 26 50
Copper wire.....	26 00 26 50

No. 1 machine com-position.....	22 50	22 00
New brass clippings.....	18 00	19 00
No. 1 brass turnings.....	16 00	16 00
Heavy melting steel.....	19 00	17 00
Steel turnings.....	9 00	8 00
Shell turnings.....	12 00	12 00
Boiler plate.....	11 00	10 50
Axles, wrought iron.....	22 00	24 00
Rails.....	19 00	18 00
No. 1 machine cast iron.....	20 09	25 09
Malleable scrap.....	20 09	20 09
Pipe, wrought.....	14 00	9 00
Scrap zinc.....	8 00	9 50
Heavy lead.....	11 50	10 75
Tea lead.....	7 50	7 00
Aluminum.....	35 00	35 00

BOLTS, NUTS AND SCREWS.

Per Cent.	
Coach and lag screws.....	25
Stove bolts.....	55
Plate washers.....	net list
Machine bolts, 7-16 and over.....	net
Machine bolts, 3/8 and less.....	10
Blank bolts.....	net
Bolt ends.....	net
Elevator bolts.....	50 and 5
Machine screws, fl. and rd. hd., steel.....	27 1/2
Machine screws, o. and fil. hd., steel.....	10
Machine screws, fl. and rd. hd., brass.....	add 20
Machine screws, o. and fil. hd., brass.....	add 25
Nuts, square blank.....	add \$1 50
Nuts, square, tapped.....	add 1 75
Nuts, hex. blank.....	add 1 75
Nuts, hex. tapped.....	add 2 00
Copper rivets and burrs, list plus.....	30
Burrs only list plus.....	50
Iron rivets and burrs.....	17 1/2
Boiler rivets, base 3/4-in. and larger.....	\$6.65
Structural rivets, as above.....	6.55
Wood screws, flat, bright.....	.72 1/2
Wood screws, O. & R., bright.....	.67 1/2
Wood screws, flat, brass.....	.37 1/2
Wood screws, O. & R., brass.....	.32 1/2
Wood screws, flat, bronze.....	.27 1/2
Wood screws, O. & R., bronze.....	.25

MILLED PRODUCTS.

Per cent.	
Set screws.....	35
Sq. & Hex. Head Cap Screws.....	30
Rd. & Fil Head Cap Screws.....	10
Flat 3/8 But. Hd. Cap Screws plus.....	10
Pin. & Semi-fin. nuts up to 1 in.....	25
Pin. and semi-fin. nuts, over 1 in., up to 1 1/2 in.....	30
Pin. and semi-fin. nuts, over 1 1/2 in., up to 2 in.....	10
Studs.....	20
Taper pins.....	40
Coupling bolts, plus.....	10
Planer head bolts, without fillet, list plus.....	10
Planer head bolts, with fillet, list plus 10 and.....	10
Planer head bolt nuts, same as finished nuts.....	net
Planer bolt washers.....	net
Hollow set screws.....	list plus 20
Collar screws.....	list plus 30, 10
Thumb screws.....	20
Thumb nuts.....	65
Patch bolts.....	add 40, 10
Cold pressed nuts to 1 1/2 in.....	add \$4.50
Cold pressed nuts over 1 1/2 in.....	add \$7.00

BILLETS.

Per gross ton	
Bessemer billets.....	\$ 95 00
Open-hearth billets.....	95 00
O.H. sheet bars.....	100 00
Forging billets.....	115 00
Wire rods.....	90 00
F.o.b. Pittsburgh.	

NAILS AND SPIKES.

Wire nails.....	5 00	4 95
Cut nails.....	5 35	5 35
Miscellaneous wire nails.....	60%	
Spikes, 3/4 in. and larger.....	6 50	
Spikes, 1/4 and 5-16 in.....	7 00	

MISCELLANEOUS.

Solder, strictly.....	0 38
Solder, guaranteed.....	0 41
Babbitt metals.....	16 to 65
Soldering coppers, lb.....	0 53
Patty, 100-lb. drum.....	4 35
White lead, pure, cwt.....	17 50
Red dry lead, 100-lb. kegs, per cwt.....	13 87
Glue, English.....	0 38
Tarred slaters' paper, roll.....	0 95
Gasoline, per gal, bulk.....	0 21 1/2
Benzine, per gal, bulk.....	0 30 1/2
Pure turpentine, single bbls., gal.....	0 72
Linseed oil, raw, single bbls.....	1 40
Linseed oil, hotted, single bbls.....	1 43
Plaster of Paris, per bbl.....	2 50
Plumbers' oakum, per cwt.....	9 00
Packing, square braided.....	0 32
Packing, No. 1 Italian.....	0 38
Packing, No. 2 Italian.....	0 30
Lead wool, per lb.....	0 15
Pure Manila rope.....	0 33 1/2
Transmission rone, Manila.....	0 43 1/2
Drilling cables, Manila.....	0 38 1/2

POLISHED DRILL ROD.

Discount off list, Montreal and Toronto.....	25%
--	-----

CARBON DRILLS AND REAMERS.

Per Cent.	
S.S. drills, wire sizes up to 52.....	40
S.S. drills, wire sizes, No. 53 to 80.....	25
Standard drills to 1 1/2 in.....	40
Standard drills, over 1 1/2 in.....	15
3-fluted drills, plus.....	10
Jobbers' and letter sizes.....	40
Rit stock.....	40
Ratchet drills.....	15
S.S. drills for wood.....	40
Wood boring brace drills.....	25
Electricians' bits.....	30
Sockets.....	40

Sleeves.....	40
Taper pin reamers.....	20
Drills and countersinks.....	list plus 30
Bridge reamers.....	45
Centre reamers.....	10
Chucking reamers.....	10
Hand reamers.....	15

COLD ROLLED SHAFTING.

At mill.....	list plus 40%
At warehouse.....	list plus 50%

Discounts off new list. Warehouse price at Montreal and Toronto.

IRON PIPE FITTINGS.

Canadian malleable, A, add 10%;	B and C, 10%;	cast iron, 35%;	standard bushings, 50%;
headers, 60%;	flanged unions, 40%;	malleable bushings, 50%;	nipples, 55%;
malleable lipped unions, 50%.			

SHEETS.

Montreal Toronto	
Sheets, Black, No. 28.....	\$10 00 \$ 9 60
Sheets, Black, No. 10.....	9 50 9 25
Canada plates, dull, 52 sheets.....	8 50 8 50
Canada plates, all bright.....	9 50 9 50
Apollo brand, 10 3/4 oz. galvanized.....	9 75 9 75
Queen's Head, 28 B. W.G.....	10 75 10 75
Fleur-de-Lis, 28 B.W. G.....	10 75 10 75
Gorbals' Best, No. 28.....	10 25 10 25
Colborne Crown, No. 28.....	10 00 10 00
Premier, No. 28 U.S.....	10 90 10 70
Premier, 10 3/4 oz.....	11 10 11 09

PROOF COIL CHAIN.

B	
1/2 in.....	\$10 75
5-16 in.....	10 40
3/8 in.....	10 25
7-16 in.....	10 00
1/2 in.....	9 90
9-16 in.....	9 90
5/8 in.....	9 75
3/4 in.....	9 50
7/8 in.....	9 40
1 inch.....	9 25
Extra for B.B. Chain.....	1 20
Extra for B.B.B. Chain.....	1 80

ELECTRIC WELD COIL CHAIN B.B.

3/4 in.....	\$15 50
3-16 in.....	11 70
1/2 in.....	8 40
5-16 in.....	7 40
3/8 in.....	6 35
7-16 in.....	6 35
1/2 in.....	6 35
5/8 in.....	6 35
3/4 in.....	6 35

Prices per 100 lbs.

FILES AND RASPS.

Per Cent.	
Great Western, American.....	55
Kearney & Foot, Arcsde.....	55
J. Barton Smith, Eagle.....	55
McClelland, Globe.....	55
Whitman & Barnes.....	55
Black Diamond.....	45
Delta Files.....	40, 5
Nicholson.....	45
Globe.....	55
Vulcan.....	55
Disston.....	35

COAL AND COKE.

Solvay Foundry Coke.....	\$10 90
Cornelville Foundry Coke.....	
Steam Lump Coal.....	8 50
Best Slack.....	8 05
Net ton f.o.b. Toronto	

BOILER TUBES.			TAPES.		ANODES.		SHEETS, 3½ lbs. sq.	
Size.	Seamless	Lap-welded					ft. 14 00 18 00	
1 in.	\$30 00		Chesterman Metallic, 50 ft.	\$2 00	Nickel	.50 to .54	Sheets, 4 to 6 lbs. sq. ft. 17 50 17 50	
1½ in.	33 00		Luffkin Metallic, 603, 50 ft.	2 00	Cobalt	1.75 to 2.00	Cut sheets, ½¢ per lb. extra.	
1½ in.	35 00	31 00	Admiral Steel Tape, 50 ft.	2 75	Copper	.44 to .46	Cut sheets to size, 1¢ per lb. extra.	
1¾ in.	34 00	30 00	Major Jun. Steel Tape, 50 ft.	3 50	Tin	.49 to .56		
2 in.	38 00	30 00	Rival Steel Tape, 50 ft.	2 75	Zinc	.23 to .25		
2¼ in.	40 00	35 00	Rival Steel Tape, 100 ft.	4 45	Prices Per Lb.			
2½ in.	46 00	36 00	Reliable Jun. Steel Tape, 50 ft.	3 50	COPPER SHEETS.			
3 in.	52 00	42 00			Montreal Toronto			
3¼ in.		48 00			Bars, ½ to 2 in.	55 00 53 00		
3½ in.	62 00	52 00			Plain sheets, 14 oz.			
4 in.	70 00	65 00			14x28 in., 14x60 in.	55 00 53 50		
Prices per 100 feet, Montreal and Toronto.					14x90, 14 oz.	60 00 54 25		
OILS AND COMPOUNDS.					Copper sheet, planished, 14x60 base.	64 00 60 00		
Castor oil, per lb.	35				Braziers', in sheets, 6x4 base	55 00 52 00		
Royalite, per gal., bulk	16				BRASS.			
Palacine	19				Brass rods, base ½ in to 1 in rd.			
Machine oil, per gal.	25½				in rd. base ½ in to 1 in rd.			
Black oil, per gal.	13				oz.			
Cylinder oil, Capital	45½				Brass sheets, 8 in. wide, 20 oz.			
Cylinder oil, Acme	36½				Copper tubing, seamless.			
Standard cutting compound, per lb.	6 15				Copper tubing, seamless.			
Lard oil, per gal.	1 45				PLATING SUPPLIES.			
Union thread cutting oil antiseptic	68				Polishing wheels, felt.			
Acme cutting oil, antiseptic	37½				Polishing wheels, bull-neck			
Imperial quenching oil	39½				Emery in kegs, American			
Petroleum fuel oil	11				Pumice, ground			
BELTING—NO. 1 OAK TANNED.					Emery glue			
Extra heavy, single and double	30-5%				Tripoli composition			
Standard	40%				Crocus composition			
Cut leather lacing, No.1	1 50				Emery composition			
Leather in slides	1 35				Rouge, silver			
					Rouge, powder			
					Prices Per Lb.			
					LEAD SHEETS.			
					Montreal Toronto			
					Sheets, 3 lbs. sq. ft. \$18 00 \$18 00			
					PLATING CHEMICALS.			
					Acid, boric			
					Acid, hydrochloric			
					Acid, hydrofluoric			
					Acid, nitric			
					Acid, sulphuric			
					Ammonia, aqua			
					Ammonium carbonate			
					Ammonium chloride			
					Ammonium hydrosulphuret			
					Ammonium sulphate			
					Arsenic, white			
					Copper, carbonate, anhy.			
					Copper, sulphate			
					Cobalt sulphate			
					Iron perchloride			
					Lead acetate			
					Nickel ammonium sulphate			
					Nickel carbonate			
					Nickel sulphate			
					Potassium carbonate			
					Potassium sulphate (substitute)			
					Silver chloride (per oz.)			
					Silver nitrate (per oz.)			
					Sodium bisulphite			
					Sodium carbonate crystals			
					Sodium cyanide, 127-130%			
					Sodium hydrate			
					Sodium hyposulphite, per 100 lbs.			
					Sodium phosphate			
					Tin chloride			
					Zinc chloride			
					Zinc sulphate			
					Prices Per Lb. Unless Otherwise Stated.			

The General Market Condition and Tendency

THERE is apparently no limit to prices of pig-iron as all indications point to further advances. A price of \$50 for Bessemer iron has been established at Pittsburgh and the market consequently is in an excited condition. Quotations of domestic pig-iron are still temporarily withdrawn, due principally to the unsettled coke situation. Coke is very high in price and supplies are not coming forward from the ovens in sufficient quantities to fill requirements. The outlook as regards coke is not at all favorable, and is causing considerable anxiety. The steel market continues strong with prices very firm. Prices of a number of steel products have recently advanced in the United States, which will doubtless be reflected in Canada shortly. The requirements of steel for war purposes are increasingly heavy and consequently steel for general purposes is becoming more difficult to obtain. The outlook for the private consumer is thus becoming more serious. Coal continues high in price and a serious situation is anticipated unless a determined effort is made to increase the supply. Prices of galvanized sheets have advanced again, but black sheets are unchanged in the meantime. There is a shortage of black sheets, as the American Government is taking over a large percentage of the output of the mills, leaving a comparatively small tonnage available for the private consumers. The non-ferrous metal markets generally are firm, but business is dull. Lead is very strong and higher, due to scarcity of supplies. Antimony is weaker and lower. There is no change in the scrap metal situation this week, although it is likely that prices of cast iron scrap and heavy melting steel will advance on account of the heavy demand. Coppers are inactive and demand light, but lead scrap is firmer. The demand for machine shop supplies continues active at firm prices, with a few advances. A fair demand for machinery for general purpose features the machine tool market.

Montreal, Que., June 11, 1917.—Despite the fact that steel requirements have apparently fallen off owing to the curtailment in the manufacture of the heavy

fer shells, the scarcity of steel is more marked than ever, and the general situation is seriously menaced by the shortage of raw materials. As the demands dur-

ing the next few months are expected to increase, the outlook for the immediate future is not encouraging, although every possible facility is being adopted to give relief to the situation. The present political situation tends to keep matters in rather an unsettled condition which can only be relieved when the pending developments take tangible form. Both the labor and coal situations possess continued interest because of their vital importance to the steel industry.

Pig Iron

The pig iron market continues to advance, reflecting very emphatically the actual condition of the iron and steel situation. The American market generally has advanced over \$2 per ton, with the Pittsburgh quotations figuring in the recent rise; Bessemer has advanced during the week \$7 per ton, the current quotation being \$53.95 per ton. Basic, at \$48.95 per ton, shows an advance of \$6 on the week. A similar advance on forge has brought it also to \$48.95. Foundry and malleable has been advanced \$3, the present price being \$48.95. Canadian producers continue practically out of the market prices being withdrawn.

Steel

Another sensational week has passed in all branches of the steel situation and the markets are much stronger. The trend of future conditions is indicated in the transactions of the past week, as the developments in the Pittsburgh district are examples of what may be expected in connection with the steel industry during the coming months. The insistent and ever-increasing demand for steel of all kinds

and the evident scarcity of scrap and old metal for remelting, would indicate that the prices of the future may far outrun any that have yet been announced. The situation is fast coming to the point where any but war requirements and those closely associated with its prosecution, will of necessity, require to be indefinitely delayed, owing to high cost of all kinds of materials. The American Government is still working on war plans and the steel and other requirements that will eventually be required, large orders for which are being placed as rapidly as possible. The shipbuilding programme is probably one of the most important and it is estimated that facilities will soon be provided for rolling sufficient steel for the construction of one 3,000-ton steel vessel per day. It is this situation that is making it so difficult, if not altogether impossible, for domestic users to secure steel. The changing conditions in the States is gradually producing a labor shortage that in time may have considerable bearing in manufacturing circles. The Canadian situation in this respect, while not very serious, is, nevertheless, quite acute, but has been somewhat relieved by the decline in the production of heavy shells; some firms, however, that were engaged in this business have continued to utilize much of their old force for the production of steel for other purposes. The lowest price quoted for Bessemer sheet bars is now \$100 Pittsburgh, and early advances are not unlikely. The Pittsburgh quotation on iron and steel bars has been advanced \$5 per ton, the price quoted being \$4.25 per hundred. The present market in blue annealed and black sheets is very firm with a strong undertone tending to higher prices within a few weeks. The Pittsburgh quotation on galvanized sheets has advanced \$6 per ton, the current price being approximately 10 cents per pound. The demand for shafting continues to be quite heavy, the discount being closer than the previous week, in some instances being only 5 per cent. off list. Following the constant rise in the cost of raw materials, the quotations on wire products have again been advanced \$5 per ton; plain wire is now \$3.70, galvanized wire, \$4.40, wire nails, \$3.75 and galvanized barb wire, \$4. Local dealers have not yet revised their prices, but may do so in the very near future. Owing to the shortage of prompt furnace coke and the difficulties contingent to deliveries, the market is very strong with the spot quotation, 75c per ton higher than last week; the price now asked being \$10.25 per ton. The general situation in this district is practically unchanged and the market is very firm.

Metals

The market has been comparatively quiet during the past week, but prices have been well maintained. The situation is being influenced by pending developments in the States and unsettled conditions will likely prevail until the plans of the government are completed and the requirements definitely announced. Copper is quiet, but the market is strong. Tin is easier abroad but is firm here. Spelter is active for futures but quiet on spot.

Lead continues to remain firm with a stronger tone. Antimony is easier on better supply. Aluminum is steady and unchanged.

Copper.—The recent demand for copper has been rather quiet. The trade appears to be awaiting the decision of the American war department regarding future requirements of copper. Sales of second-hand metals for early delivery are the feature of the market, being brought about by prevailing high prices. New York prices are firm at last week's quotations, and dealers here are still quoting those of the previous week, 38½c for lake and electro, and 37½c. for castings.

Tin.—The situation has been featured by a marked decline in the prices quoted for this metal, both on the London and New York markets. The possible cause for this may be accounted for by the possibility that shipping permits from England may be more easily obtained, and the fact that the transportation risk has apparently been decreased. The sharp decline on the London market has also been a factor in the easier tone in New York; the quotation on the latter being now 61c. per lb., a decline on the week of 3c. per lb. Dealers here are quoting 62½c. on a steady market, but the undertone is weaker, especially for large quantities.

Spelter.—A peculiar situation now features the spelter market in the fact that the spot market is easier than for futures, but this condition is becoming less pronounced as the producers take a more optimistic view of the future. Operating conditions, both in the ore fields and at the smelters, are not favorable for any further decline in the price of this metal, and producers are holding out better hopes for the future when the plans of the American government are further developed. New York continues to quote 9½c. on a quiet market. Dealers here are quoting 13c. on small quantities, a decline of ½c. per lb.

Lead.—The firmness of the market is well maintained and the scarcity of the supply is one of the main factors for the strong position of this metal. Increased facilities for production in the near future afford some relief to the outlook for this metal, but at present the market is increasing in strength. A further advance has been noted on the New York market, the trust price having advanced one cent and the independents ½c. per lb.; prices quoted being 11 and 12 c. respectively. The market here is also stronger, an advance of ½c., bringing the price up to 14c. per lb.

Antimony.—Less demand and increased supply has developed a weaker market and prices have, therefore, declined. New York is quoting 21c., this being 1½c. lower than a week ago. The local market is easier and prices quoted are one cent lower than last week, the dealers asking 25c. per lb. on small lots.

Machine Tools and Supplies

No feature of special interest has developed to alter the general machine tool situation and the market continues to reflect more normal conditions in every direction. The demand for munitions ma-

chinery during the week just passed has shown slight improvement over that of the previous week, but the requirements for this purpose are now largely for those plants that are increasing their present output, or where it has been found necessary to replace old or obsolete tools. Apart from the munitions demand, however, the requirements for general purposes continue to show a marked increase, and in this connection it might be said that the trade generally would probably be considerably greater but for the higher prices that are constantly being asked for all classes of equipment, this being a necessary factor owing to the excessive cost of all raw and semi-finished materials.

Scrap

An evident scarcity has developed in pig iron and steel scrap and the market in these old metals has become stronger with the continued heavy demand. The general tone of the market has an upward tendency as the insistent requirements for steel of every description make it imperative that productive be maintained no matter at what cost. Firmness prevails in the local situation, with steel-making scrap very strong and advancing; No. 1 machine composition has been advanced 1 cent, the present quotation being 22½c. per lb. Steel turnings show a similar advance, the price quoted being 9c. per lb. Machine cast iron and malleable scrap have been advanced 3c. during the week, the current quotations being 25 and 20c. respectively. Heavy lead is one cent stronger at 11½c. per lb. Aluminum on a 3c. rise is quoted at 35c. per lb.

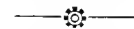

Toronto, Ont., June 12.—That a price of \$50 has been paid for Bessemer pig at Pittsburgh is a matter of considerable importance, as it shows distinctly the general trend of prices, not only of pig iron, but also of steel. Less than one year ago the same grade of iron was selling at around \$18, so that in a comparatively short time the price has been nearly trebled. In some quarters it is firmly believed that the \$75 mark will be reached, which is not at all unlikely in view of prevailing conditions. The cause of the extraordinary high prices of pig iron is due to the law of supply and demand, and not to any artificial boosting.

Steel

Notwithstanding the prevailing high range of steel prices there is no sign that the top has been reached, in fact all indications point to a continuance of the upward movement for an indefinite period. The recent advance in prices of many lines of steel products in the States will doubtless be reflected in the Canadian market shortly. The \$50 mark for Bessemer pig iron has been reached at Pittsburgh and created a situation which is bound to affect prices of steel. Higher prices on iron and steel bars and structural shapes are looked for in the near future, while an advance on wrought pipe is likely at no distant date. Pressed steel spikes have advanced and are now quoted at \$7 for ¼ in., and 5-16 in., and \$6.50

for $\frac{3}{8}$ in. and larger. Cut nails are also up, being now quoted at \$5.35 per keg base. Plate washers are now net list as against 10 per cent. off formerly. The steel plate situation continues very tight and material is more difficult to obtain than at any time before. Prices are practically nominal as it is almost impossible to quote prices on plates that are accurate, and that correctly represent the market. On nearly every sale of plates that is made, the mill takes into account whether the buyer is a regular customer, what the plates are to be used for, and the deliveries wanted. The present enormous demand is largely for ship construction and the market is practically dominated by the American Government requirements of plates for this purpose.

The shortage of steel is becoming more acute as requirements for war purposes are growing heavier. The high cost of steel and difficulty of obtaining supplies is tending to curtail the demand for ordinary purposes. Private consumers cannot obtain material in sufficient quantities and are thus in many cases severely handicapped in operating their plants. Deliveries are getting more backward all the time and the delays in getting steel, although unavoidable, create a difficult situation for the manufacturing consumer to contend with.

As Government requirements of sheets have monopolized output of the mills in the States, makers are having the greatest difficulty in providing for their ordinary customers. The demand for sheets for Government war requirements is increasing rapidly; in fact, makers are finding it more difficult to provide for tonnages as they come out. Only quite a few mills are in the market, and they are offering only limited tonnages at comparatively high prices for nearby shipment. Prices of black sheets are very firm and may advance any time. Galvanized sheets have again advanced, Premier No. 28 being quoted at \$10.70, and 10 $\frac{1}{4}$ oz., at \$11.50.

Prices of steel products in the United States have again advanced, affecting principally iron and steel bars, skelp, open-hearth sheet bars, and forging billets. The problem at the present time is to apportion the requirements of steel so as to give a fair share and to provide at the same time for the urgent needs of the American Government and the Allies. The rail market is particularly strong. Large orders for rails from Russia, Great Britain and France have recently been placed with U.S. mills. Conditions in the rail branch of the steel industry are such that there must necessarily be a long delay before orders in prospect can be filled. The earliest shipments that can be hoped for will hardly be before the second half of 1918, and the balance will run into 1919. The unfilled tonnage of the U.S. Steel Corporation on May 31 was 11,886,591 tons, being a decrease of 296,492 tons from April.

Pig Iron

The genuine scarcity of pig iron which is generally acknowledged to be serious has brought into the market many buyers

who have hesitated. There seems no doubt as to the stability of present prices notwithstanding the high level reached. There is apparently no limit to prices. The long predicted price of \$50 for Bessemer iron has been established, this being the current quotation for this grade at Pittsburgh. The steady advance in prices of pig iron is due partly to high cost of fuel and coke and continued shortage of labor, in fact the cost of everything having to do with the production of iron has gone up to extraordinary heights. The principal reason, however, for the high price of iron is the question of supply and demand. More iron is wanted than the furnaces can supply. Local prices are still temporarily withdrawn owing chiefly to the uncertain coke situation. Connellsville coke which was selling a year ago at \$2.75 is now firm at \$10 ovens. Supplies are also uncertain and causing considerable anxiety to consumers.

Scrap

The market is quiet and prices unchanged on the basis of last week's quotations. Business has been dull during the

CANADIAN GOVERNMENT PURCHASING COMMISSION

The following gentlemen constitute the Commission appointed to make all purchases under the Dominion \$100,000,000 war appropriation:—George F. Galt, Winnipeg; Hormidas Laporte, Montreal; A. E. Kemp, Toronto. Thomas Hilliard is secretary, and the Commission headquarters are at Ottawa.

week. It is possible that prices of heavy melting steel and cast iron scrap may go higher. There is a scarcity of both these materials and in view of the heavy demand it is likely that prices will advance. In the meantime quotations are firm and unchanged.

Machine Tools

Nothing of particular importance has developed in the machine tool market. Business is gradually assuming a more normal aspect and the demand for tools for general purposes is the principal feature. Canadian machine tool builders continue to be steadily employed on both domestic and export business, the situation in this respect being satisfactory.

Supplies

Business continues active at firm prices. Cast iron and malleable fittings have advanced. Machinist's and parallel bench vices have been advanced approximately 10 per cent. An advance of 10 per cent. has also been made in brass globe, angle and check vales.

Metals

Although trading in metals has not been particularly heavy during the week the markets generally have been firm and prices well held on the basis of last week's

quotations. An exception must be made, however, in regard to antimony, which has declined, while on the other hand lead has advanced. Some uncertainty prevails in the metal market as the American Government requirements have not yet been made known, but it is generally believed that the Government's buying will be heavy, and in anticipation of this the markets are firm and buoyant. Lead is the most interesting of the metals just now owing to its strong position and steady advance in price. Copper continues stationary and the market is quiet, waiting developments. The excitement in the tin market has passed off, but the market is holding steady with buyers holding off also waiting developments. Spelter is quiet and unchanged, as is also aluminum. Higher prices on solders may be looked for if lead continues to advance.

Copper.—Buyers continue to hold off pending the long-expected announcement, which is due shortly, with regard to the requirements of the American Government for copper. In the meantime the market is nominally unchanged. The earlier positions up to August are all sold up by the leading producers and can only be obtained in limited quantities through brokers and dealers. The undertone of the market continues strong. Copper is quoted locally as follows: Lake and electrolytic, 37c, and castings, 36c per lb.

Tin.—The market is steady and prices although unchanged may possibly decline in the near future on account of the easier situation in New York. This is due mainly because demand is light, arrivals have recently been fairly large and shipping permits are likely to be more readily obtainable. Advices from Washington announce that new arrangements are pending between the British and American Governments whereby there would henceforth be a more equitable allotment of tin between consumers in the United States. The benefit derived from this will be reflected in the Canadian situation. Local quotations are unchanged and nominal at 66c. per pound.

Spelter.—Business is dull but quotations are firm with indications of higher prices. The opinion is held in some quarters that a decline in prices is unlikely under present operating costs and that any improvement in demand would send prices up. Local price 12c. per pound.

Lead.—Continued strength characterizes the lead market and the price has again advanced. The "Trust" has advanced its price to 11c. New York, while "Independents" are quoting 12c. New York. The demand for lead has been very heavy and as the leading producers have offered none for sale for many weeks, consumers had to depend on independent concerns. The market at once began to stiffen and has been growing stronger and higher ever since the withdrawal of the leading producers. Lead has advanced $\frac{1}{2}$ c. locally and is now quoted at 14 $\frac{1}{2}$ c. per pound.

Antimony.—The market continues quiet with lack of demand for prompt antimony, although there is a growing demand for future shipments. The local

situation is weaker and the price has declined 4c. to 26c. per pound.

Aluminum.—The market is firm in anticipation of heavy demand for war purposes. In the meantime quotations are unchanged at 68c. per pound.

Sydney, N.S., June 9.—The Glace Bay collieries of the Dominion Coal Co. produced in May approximately 328,000 tons, comparing with 353,000 tons in May, 1916. The aggregate production for the first five months of the year shows a decline of 225,000 tons when compared with the corresponding period of last year. Indications are, therefore, that the first half of 1917 will show a reduction in production from 1916 of almost a quarter of a million tons. The rate of decline in the second half of the year will not be so marked, as the monthly tonnages will then compare with a period of 1916 when the decline in outputs had become very pronounced.

A large amount of coal is stored on the ground at Glace Bay, and stocking is still proceeding because of the lack of shipping tonnage to transport the coal to a market. It is an unprecedented circumstance to be stocking coal in June, and, of course, this procedure cannot long continue, as it would be dangerous practice to stock fresh mined coal in the hot weather. The shipping shortage is the result of admiralty requisitioning of the coal-shipping fleet.

The Mines Branch have deputed J. G. S. Hudson, of that Department, to investigate on the ground the questions of coal production and transportation in Nova Scotia. There should be very little difficulty in this investigation, because two factors only are involved, first, a shortage of mine labor, and second, a shortage of transportation facilities both by rail carriage and water freighting. The first condition is not capable of remedy during the continuance of the war. Because of the restriction of enlistments among miners, the decline in outputs has been to an appreciable extent arrested, but no increase in production is possible. The matter of transportation is capable of remedy, if suitable action is taken by the authorities in charge.

The prospects of a coal famine in Canada become daily more evident and inevitable. Conditions among coal consumers and the poor in the large cities of Canada next winter will be such as to justify the most serious apprehension among those who realize what is coming. Coal operators in the United States will not make contracts to-day, and will not in many cases even quote. A large coal dealer in the Maritime Provinces recently sent out in one day thirty-six telegraphic enquiries for coal quotations to operators in the United States. Replies refusing to quote were received from eighteen operators, and the other eighteen did not bother to reply. This is a typical case, and many others could be adduced.

In face of these conditions a coal strike in the Western collieries, and the possibility that Nova Scotian collieries may have to curtail production because of lack of transportation, seem to call for some serious thinking and definite action

by whatever powers may be in these chaotic days.

Pittsburgh, Pa., June 9.—There is no longer any buying of consequence in steel products for far forward delivery—the only delivery the large steel mills can make, as they are sold up in their various departments for an average of about ten months, some farther than that, some not so far. Evidently buyers do not care to take chances, nor mills make contracts, so far ahead. Prices formerly recognized as the regular market “for delivery at mill convenience” have, therefore, practically disappeared, and such market as exists is made by mills not completely sold up, chiefly the smaller establishments, who can arrange for some deliveries in from three to six months. For such, prices are, in many instances, higher than those of a fortnight ago.

For delivery a few months hence, prices are approximately as follows: Merchants bar, 3.75c. to 4.25c.; structural shapes, 4.25c. to 4.50c.; tank plates, 7c. to 8c.; ship plates, 9c. to 10c. or higher; wire nails, \$3.50 to \$3.75; hoops, 4.50c. to 5c.; blue annealed and black sheets, 7.50c.; galvanized sheets, 9.50c. to 10c. These prices are generally named only to domestic buyers, there being little disposition to quote on export business. There is ground for suspicion that the market is already lining itself up for a decline in prices as it has already had a decline in activity, though not, in all probability, in less than about five or six months from now.

War Steel

The present outlook is that a larger proportion of the steel output will be marshalled for war purposes than was estimated at the outset, when 20 per cent. was considered altogether an outside estimate, and 10 per cent. was regarded as possibly excessive. In the first place, the view is much more general that the war is likely to last one, two or more years still. In the second place, the amount of steel needed for transportation purposes is very much larger than anyone assumed even a few weeks ago. The information furnished by the British, French and Italian Missions is perhaps responsible for this change in appraisal, while the collapse of the wooden ship program accounts for a large quantity of steel that will be used in building small steel freighters.

For instance, while orders for 500 locomotives and 10,000 cars were arranged recently for Russia, under the auspices of the Advisory Commission of the Council of National Defense, the Commission, working through a car committee of which S. M. Vauclain is chairman, is negotiating with the car builders for a total of no less than 100,000 cars. Where these cars are to go is not stated, but it may well be assumed that they are to go chiefly to Russia and France, with probably a fair proportion to be placed on American roads, which are themselves in need of cars. There is no word of similar negotiations as to locomotives, but that will no doubt come also.

The tonnage of sheets required pro-

mises to be large, quite in excess of most recent estimates. It turns out that sheets are a particularly useful form of finished steel for war, as there are sheet requirements for tent pins, tent stoves, camp ranges, ammunition sheds, aeroplane hangars, helmets, mines, net floats, and probably various other things of which we have not yet heard. The Government buys the finished products and the factories involved buy the sheets, exhibiting the necessary documents whereby a concession in price—not stated—is granted, and a committee of sheet manufacturers is to see that the participation of the various mills is in proportion to their capacity.

The scarcity of sheets produced by the filling of these requirements may not be as severe as was expected. Automobile makers foresee a smaller demand for pleasure vehicles and some have already curtailed their specifications to mills. Hudson is going to abandon pleasure cars entirely and will make trucks only.

Pig-Iron and Scrap Famine

By far the most important development in the general iron and steel market is the famine, or prospective famine, in pig iron and scrap. There have been large increases in steel-making capacity, but scarcely any in blast furnace capacity, while on account of deficiency in coke supplies, due to car shortage in the Connellsville region, pig iron production was greatly curtailed in the winter, by close to 10 per cent., and even in the past two months the supply has not been fully adequate, as with more furnaces in blast the output has been somewhat less than in last October and November. Until recently the whole matter of production has been one of steel-making capacity, there being plenty of pig iron for the Bessemer converters and open-hearth furnaces, and plenty of rolling capacity to turn the ingots into finished products. Now the thin neck of the bottle is to be the blast furnaces instead of the steel-making departments, unless all signs fail. The production of steel the remainder of this year will be larger than in the same period last year, but the limit will be determined not by the steel-making capacity, but by the raw materials available.

One More Thing.—Pat and Bridget were being married, and the whole village was astir. Pat was resplendent in a tail coat (borrowed), patent leather boots (too tight for him), a white vest, and a bright green tie; Bridget shone glorious in most of the colors of the rainbow.

The fateful words were spoken, and the happy pair walked down the aisle and out into the street, where a great crowd greeted them with loud cheers.

At last they were safely, esconced in their cab, and Bridget sank back with a sigh of satisfaction.

“Sure, Patrick,” she said sadly, “there’s only one thing Oi regret. If we eud have stood on the pavemint and watched ourselves pass, wouldn’t it have been hivinly?”

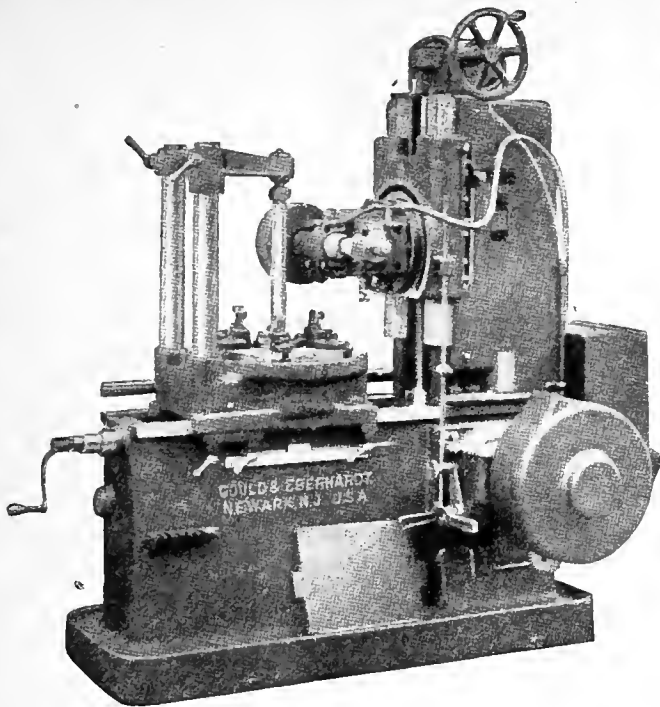

Gould & Eberhardt GEAR HOBBERS

are
Automatic therefore Economical

If you cut gears in quantities they can be cut with advantage on G. & E. Gear Cutting Machinery.

For gears up to 120" dia.

Catalogue describing full line of Gear-cutting, Hobbing and Rack-cutting machines on request.

Write for prices and deliveries

The A. R. Williams Machinery Company, Limited

ST. JOHN, N.B.
WINNIPEG, VANCOUVER

"If It's Machinery, Write Williams"

64 Front Street West,
TORONTO

The Devil

Gets into everything that is not barricaded against him.
He even gets into screw threads.

GEOMETRIC

Self-opening Die Heads and Collapsing Taps guard against deviled threads. They keep him out of a man's work as well as out of his disposition.

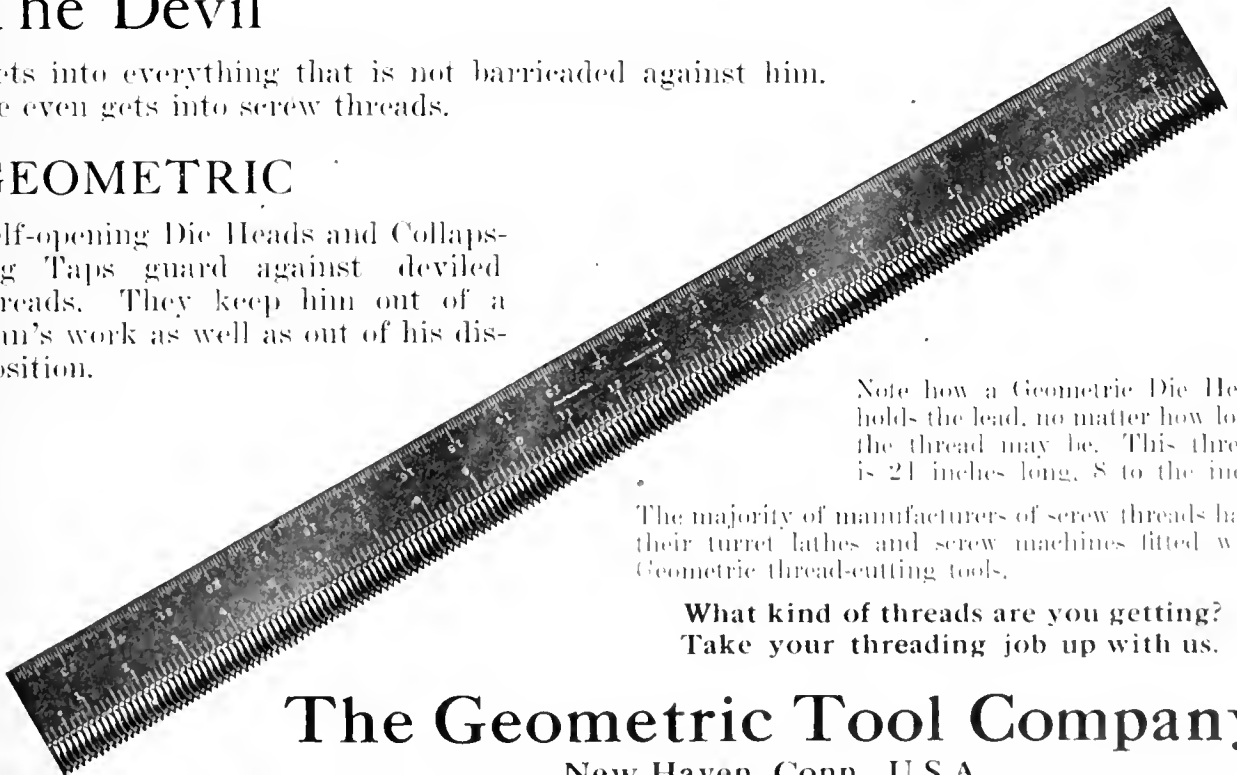

Note how a Geometric Die Head holds the lead, no matter how long the thread may be. This thread is 21 inches long, 8 to the inch.

The majority of manufacturers of screw threads have their turret lathes and screw machines fitted with Geometric thread-cutting tools.

What kind of threads are you getting?
Take your threading job up with us.

The Geometric Tool Company

New Haven, Conn., U.S.A.

CANADIAN AGENTS: Williams & Wilson, Ltd., Montreal; The A. R. Williams Machinery Co., Ltd., Toronto, Winnipeg and St. John, N.B.

If any advertisement interests you, tear it out now and place with letters to be answered.

INDUSTRIAL ^A_D CONSTRUCTION NEWS

Establishment or Enlargement of Factories, Mills, Power Plants, Etc.; Construction of Railways, Bridges, Etc.; Municipal Undertakings; Mining News

ENGINEERING

Princeton, B.C.—The British Columbia Copper Co., will install a power plant and mill shortly.

Toronto, Ont.—The Hoyt Metal Co. will build an addition to its factory on Eastern Avenue.

Prince Rupert, B.C.—It is proposed to establish a new cold storage plant here to aid the fishing industry.

Estevan, Sask.—The C. P. R. is installing a gas producer plant and a 30-h.p. Canadian Fairbanks-Morse Co.'s gas engine in their pumping station here.

Collingwood, Ont.—Electric transmission lines are being installed to carry increased power to the Wm. Kennedy Co.'s plant and the electric furnaces will be in operation shortly.

Moose Jaw, Alta.—George Harrison, managing director of the Saskatchewan Bridge & Iron Co., of this town, has invented and built a gas producing plant for burning straw as fuel.

Newcastle, N.B.—The International Shipbuilding Corporation which is erecting shipyards at Newcastle, N.B., has taken over the plant and business of the Sydney Foundry Co., Sydney, N.S.

Niagara Falls, Ont.—The Norton Co. will build this year another unit to their plant at Chippewa for making abrasives. They have installed a waterworks system recently with a mechanical filtration plant.

Owen Sound, Ont.—The Union Cement Co., which has been recently incorporated with a capital of \$1,000,000 propose making extensive alterations to their plant and installing new machinery and equipment.

Belleville, Ont.—The buildings in connection with the Cordova Mine in Marmora Township, which were recently destroyed by fire entailing a heavy loss, are being reconstructed. A new process for the treating of ore is also being installed.

Beeton, Ont.—The Hydro-Electric Commission is at present considering the advisability of bringing power from Big Chute to Cookstown, thence to Alliston. There would probably be a sub-station at Nicolston, from which a line would be run to Beeton and Tottenham. Bradford will probably obtain power from the same source.

Niagara Falls, Ont.—Forty miles of steam railway will be laid in connection with the construction of the seven mile canal which will be dug to carry water from Chippawa Creek to the Hydro Electric power Commission's proposed new power plant at Smeaton's Grove near Queenston. The purchase of the right of way for the canal has been completed. Such lands as are not needed

for canal purposes will be re-sold for industrial sites. The estimated cost of the canal is \$9,000,000; of the power house, \$6,000,000.

BUILDING

Toronto, Ont.—A building permit has been issued by the City Architect for a bank and office building at the corner of St. Clair Avenue and Vaughan Road to cost \$34,000. The Bank of Commerce will establish a branch in the building.

Hamilton, Ont.—The ratepayers of the Homedale district of Barton Township have passed a resolution to request the township council to issue debentures for \$27,000 to pay for the cost of building a four-room addition to Fairfield School.

Montreal, Que.—On the recommendation of the Works Committee, the Catholic School Commission decided to build an additional storey to St. Philomene School, in Rosemount. The cost will amount to about \$30,000, and Architects Vautrin and Bernier were instructed to draw the plans accordingly.

Montreal, Que.—At a meeting of the Catholic School Board, J. A. Durocher was awarded the contract for the building of the Lasalle Academy, for the sum of \$165,150. The tender of Ulric Boileau offering to build St. Mark's School for the sum of \$140,000 was accepted. This school will be of concrete.

MUNICIPAL

Montreal, Que.—One of the aqueduct projects provides for the construction and operation of a municipal artificial ice plant.

St. Genevieve de Batiscan, Que.—The Town Council will install a pumping plant to cost \$9,000, and is calling for tenders. Tenerede Trudel is clerk.

St. Catherines, Ont.—Three by-laws will be submitted for the approval of the ratepayers on June 25, to aid by way of a bonus and partial exemption from taxes the following concerns. The Bonner-Heddle Co., St. Catherine Brass Works and St. Catherines Silk Mills.

Winnipeg, Man.—Anticipated revenue and receipts for the city's hydro-electric system for the fiscal year 1917-1918, placed the estimated revenue at \$1,050,000 and the expenditure at \$980,179.98. The profit estimated is therefore \$70,000. The present surplus of \$173,348.71 will go towards extensions now being made at Point du Bois, the contract for which is \$185,000.

Montreal, Que.—A. Pion the contractor who undertook to complete the contract for the Lasalle bridge for \$260,000 has notified the Board of Control that he was unable to carry on the work as he could not furnish the security for

the steel work. Mr. Pion told the Board he would be quite willing to contract to do the work for the city on a commission basis of 10 per cent. of what it would cost, the city to furnish security for the steel.

Windsor, Ont.—By a vote of 214 to 7, ratepayers of Ford last Saturday approved of a by-law to grant tax exemptions to the Chalmers Motor Car Co., in return for which this concern will erect a factory in the town. This is the first industrial by-law voted on in Ford since it was incorporated as a separate municipality six years ago. The Chalmers Co. will be exempt from paying taxes, other than school and local improvements, for ten years. The factory was destroyed by fire about two months ago.

Montreal, Que.—After a conference with the consulting engineers, Messrs. Vautelet, McRae, & St. Laurent, the Board of Control resolved to instruct the chief engineer to prepare plans showing the modifications required according to the engineers in projects 2, 4 and 5 of the aqueduct. It was further resolved by the board to instruct the chief engineer to prepare specifications for the supply of electricity for pumping purposes. The board also decided to get comparative information on buying electric power for pumping by hydraulic power, with the present project modified, as suggested by the said engineers.

PERSONAL

William Dott, Liverpool, manager for the Allan Line Steamship Co., died there on June 2.

R. W. Knight has severed his connection with the Standard Steel Construction Co., Welland, Ont., and will shortly return to the United States.

Horace N. Dorling has resigned from his position of inspector for the Imperial Munitions Board to join the sales staff of the Albany Pump Co., Toronto.

H. C. Herpel engineer for the Page-Hersey Iron, Tube & Land Co., Welland, Ont., recently went to Cohoes, N.Y., where the company has purchased the Cohoes Rolling Mills.

W. R. Burge, who recently resigned as Toronto manager of the Jenckes Machine Co., is now a member of the Ontario sales organization of the Canadian Allis-Chalmers, Ltd., Toronto.

Capt. Joseph A. Tymon, one of the best known of inland water sailors, and for many years commander of a Toronto Ferry Co. steamer, passed away on June 5 at his residence, 227 Logan Avenue, Toronto, aged 50.

H. Victor Brayley, has resumed his connection with Gunn, Richards, Ltd., of Montreal and New York, and will be

Aikenhead's NEW CHUCK

After All—

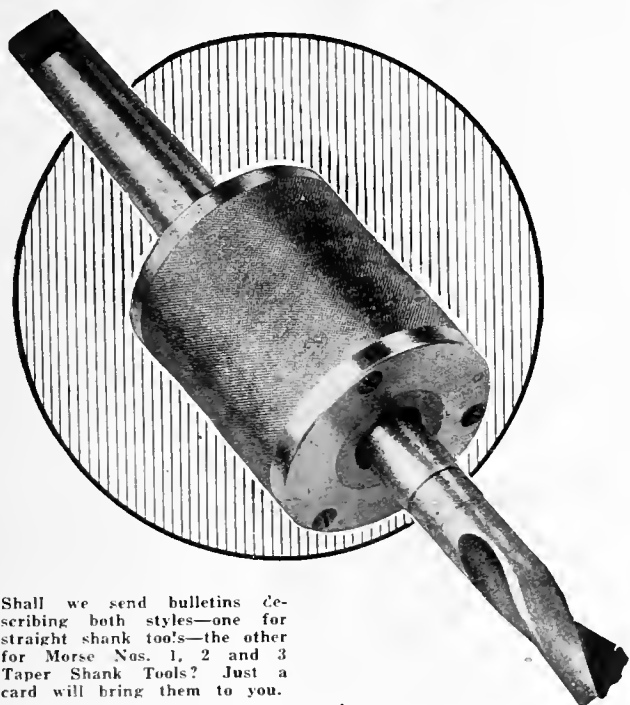

It's production that counts—and it's the simplifying or eliminating of every unnecessary step in every operation that makes for multiplied production. We have told you in their own word—how such representative firms as Pierce-Arrow, Cleveland Automatic Machine Co., and others have boosted their output in drilling, reaming, counterboring and tapping operations in a big way by using

Wahlstrom Automatic Chucks

(They reduce every unnecessary step in drilling operation—no collets—no keys—tool changes made without stopping spindle)

But—no matter how much we tell you about the time-saving possibilities of these chucks—you will never know what they will do in your shop until you've tried them out yourself.

We have a demonstration offer that you should investigate—you can put the Wahlstrom to any test you desire for ten days—if it doesn't perform every operation better and quicker than any chuck in your shop return it to us at our expense.

AIKENHEAD HARDWARE LTD.
17, 19, 21 Temperance St. Toronto, Canada

Shall we send bulletins describing both styles—one for straight shank tools—the other for Morse Nos. 1, 2 and 3 Taper Shank Tools? Just a card will bring them to you.

Aikenhead's M-6 Shell Machine

for cleaning out insides of 4.5 inch Howitzer and 6-inch shells and for retouching rough spots.

This machine has been used with immediate success in a number of large shell factories in Canada. A 14 1/2" special spindle is supplied for 4.5 shell work and a 20" spindle is used on 6" shell work. Specially adapted for cleaning the base of shells *inside*.



The Strand flexible shaft has a *metal casing* that will outwear any other now on the market and adds life to the shaft.

Does away with the trouble common to other flexible shafts. Freely flexible to a certain radius, where it automatically forms a stop, thus preventing accidental short bends.

For full particulars write

AIKENHEAD HARDWARE LIMITED
17, 19, 21 TEMPERANCE STREET, TORONTO

If any advertisement interests you, tear it out now and place with letters to be answered.

joint Canadian manager with T. Max Fyshe, Mr. Brayley resigned from Gunn, Richards, Ltd., a couple years ago.

E. P. Brady has been appointed general manager of Canadian Government Railways west of the St. Lawrence, and his headquarters will be at Cochrane, Ont. **W. A. Cowan** has been appointed as his assistant. **C. A. Hayes** will be manager of the Government railways east of the St. Lawrence River, which includes the Intercolonial Railway and its branch lines, and also the Prince Edward Island Railway.

Howard G. Kelley, has been appointed acting president of the Grand Trunk Railway in place of **E. J. Chamberlin** who has been granted three months leave of absence. Mr. Kelley was born in Philadelphia, Pa., in 1858. He came to the G. T. R. system as chief engineer, 1907-1911, and since 1911 he has been vice-president of that railway. He was president of the American Railway Engineering and Maintenance of Railway Associations in 1905 and 1906.

Sir George J. Bury, vice-president and general manager of the C. P. R., who is created a Knight, was born in Montreal in 1866, and his promotion has been rapid. At the age of twenty-one he entered the employ of the Canadian Pacific as a clerk in the office of the purchasing department. In 1894, Mr. Bury was made general superintendent of the central division of the road, with headquarters at Winnipeg, and in 1908 he became general manager of the Western lines. In 1911 he was appointed to succeed Sir William Whyte as vice-president and manager of the company's Western lines, with headquarters at Winnipeg. Two years ago he was appointed vice-president at headquarters, Montreal, and general manager of the system.

TRADE GOSSIP

Elmira, Ont.—The Elmira Transmission Co., propose building a foundry.

Toronto, Ont.—The Consumers Gas Co., will build an extension to their plant.

New Toronto, Ont.—Brown's Copper & Brass Rolling Mills, Ltd., have increased their capital stock to \$5,000,000.

Bracebridge, Ont.—The Muskoka Foundry Co., has purchased linen mill property, and will be in the market for machinery, new tools, motive and shafting, etc.

Toronto, Ont.—The Swift Canadian Co., are extending their packing house at West Toronto. The Sherwood Construction Co., of Toronto are the general contractors.

The Turbine Equipment Co., Toronto, have sold to the Midwest Refining Co., two-De Laval combination steam turbine driven boiler feed pumps, suitable for 3000 boiler h.p.

St. John, N.B.—The Power House and laundry will be built in connection with the General Hospital here. Complete equipment is required. F. Neil Brodie of St. John is the architect.

Gravenhurst, Ont.—The National Potash Corporation have now begun operations at their plant at Gravenhurst, Ont., with a battery of blast furnaces capable of reducing 200 tons of feldspar per hour.

No Coal From Alberta.—The Alberta Government has decided to insist that no fuel be shipped out of the province until the industries and citizens are equipped for the winter. This means that British Columbia, Saskatchewan and Manitoba cannot secure coal from these mines.

U.S. Steel Tonnage.—The unfilled tonnage of the United States Steel Corporation on May 31 was 11,886,591 tons, according to the report issued a few days ago, a decrease of 296,492 tons from the April 30 figures, which were the highest in the history of the corporation.

Thetford, Que.—The Regent Asbestos Corporation, which owns close to 400 acres in the asbestos district of Thetford, will resume operations owing to the improvement in the market. Orders have been given to have the pit pumped out immediately.

Hamilton, Ont.—The Steel Company of Canada have purchased the steel mill at Morrisburg, Ont., and propose removing the entire plant to Hamilton, if the city will sell some property adjoining the company's works. The Board of Control have the matter under consideration.

Allocate Pig Iron.—The American Iron and Steel Institute has been asked by the Department of Commerce, Washington to name a committee to allocate pig iron in the United States. The British Government has assured the United States that its shippers will observe any regulation by such a committee.

The Turbine Equipment Co., Toronto, have been awarded a contract by the Imperial Oil Co., Ltd., Sarnia, Ont., for two-De Laval 14 in. single stage centrifugal pumps, each having a capacity of 9 million gals. a day against 108 ft. total head. Each of them will be direct connected to Canadian Westinghouse 225 h.p. motors.

Large Copper Output.—In the first four months of this year the principal copper mines of North and South America produced a total approximating 715,000,000 pounds. Of the 715,000,000 pounds produced to date in 1917, Anaconda was responsible for nearly 114,000,000 pounds, with Phelps-Dodge Corporation properties second with a total of 64,000,000 pounds.

The International Malleable Iron Co., Guelph, Ont., have about completed an addition to their factory 216 x 100 feet, which will shortly be in operation. Another extension 90 x 60 feet is being built. New smelting furnaces and annealing ovens when installed will increase the output by 50 per cent. or 3000 tons per year. The satisfactory increase in demand for the company's product has made these extensions necessary.

Will Appoint Fuel Commission.—It is

understood that the Dominion Government will shortly appoint a fuel commission which will be given power to take over and operate the mines in the West now tied up with a strike. This will be done as a war measure, and follows the failure to effect a settlement of the difficulty.

Canal Traffic Light.—The statistical report of lake commerce through the canals at Sault Ste. Marie, Michigan and Ontario, for the month of May, 1917, show a large decrease over last year. This showing was due to the almost unprecedented ice conditions over the Great Lakes. The largest decrease is shown in iron ore, of which 5,436,467 tons were locked through, compared with 15,837,114 tons in May, 1916. Grain and wheat show a slight increase, all other items showing decreases.

Sidney, N.S.—Work has commenced on the \$3,000,000 coke oven plant for the Dominion Iron & Steel Co. for which the H. Koppers Co., of Pittsburg, Pa., are the general contractors. The plant, which will consist of 120 ovens, will take from eighteen months to two years to complete, but it is expected that the first oven will be ready for use about March, 1918. The construction will be supervised by experts of the By-Products Coke Co. of Canada, Ltd.

F. N. McClean & Sons, consulting and mechanical engineers, have equipped the top floor of the Review Building at Niagara Falls, Ont., with machinery for the manufacture of wire forming and other special automatic machines, and for the manufacture of jigs, dies, etc. Mr. McClean was formerly mechanical superintendent of the Dominion Chain Co., at Niagara Falls and also of the McKinnon Dash Co's. plant at St. Catharines.

Belleville, Ont.—The Town Council have awarded the following contracts to the Turbine Equipment Co. of Toronto. One-De Laval 6 in. 2-stage centrifugal pump, direct connected to a 150 h.p. motor, having a capacity of 225 million gals. a day against 250 ft. total head. Two-De Laval 6 in. 2-stage pumps. One to have a capacity of 1¼ million gals. a day against 250 ft. total head, and to be direct connected to 125 h.p. motor, and the other to have a capacity of 1,100,000 gals. a day, and to be direct connected to 100 h.p. motor.

Oppose Increase in Freight Rates.—Strong opposition to the application of the railway companies that the Dominion Railway Commission recommend the passage of an order in Council to advance all passenger and freight rates fifteen per cent. as a war measure was made before the Commission at its session in the Provincial House, Vancouver, B.C. The opposition came from members of the Vancouver Board of Trade and representatives of the large industries, who also opposed the proposed increase in the rail and water rates from Eastern and Western Canada.

Nickel Refinery Soon to Open.—Ambrose Monell, president of the International Nickel Co., in the annual report, says

that construction of the new refinery at Port Colborne, Ont., is proceeding at a rapid pace, in view of the difficulties in securing labor and materials, and it is expected that the plant will be in operation at the beginning of 1918. This property is located at the Lake Erie entrance of the Welland Canal. The cost of the refinery when completed is expected to be \$5,000,000. Up to the close of the fiscal year the actual expenditure on construction had been \$1,046,740.

Detachable Engines Replace Canal Horses.—The first stage of a striking experiment in inland water transport was completed with the arrival in London, England, the other day of two barges laden with coal from collieries in the north of England. The barges were propelled for 160 miles by a detachable motor. The new device consists of a four-cylinder, 17 horsepower marine engine, capable of hauling two boats with a load of 100 tons. It is mounted on the top of the cabin, and controlled from the helm. Petrol is employed for starting, and paraffin when running. The engine and attachments can be transhipped from one barge to another in a few minutes, and it is stated that its use means economy in time and money by comparison with towing by horses.

Winter Port Business at St. John, N.B.—During the winter season just ended the exports handled by the C.P.R. at West. St. John aggregated a total of 1,111,957 tons, an increase of 200,582 tons over the previous winter's total. The C.P.R. grain shipments for the winter were 9,000,000 bushels in round numbers; last year they were 13,000,000 bushels. The total of imports handled by the C.P.R. in 1916-17 amounted to 84,629 tons, an increase over last year of 19,312 tons. In addition to the traffic above mentioned, there were large shipments of exports and imports on the East Side which will swell the total of the port's business up to a very large amount. It is estimated that slightly over \$1,000,000 were paid out in wages of checkers and longshoremen during the winter.

Large Contracts for Railway Equipment.—It is estimated that the total contract prices for railroad equipment placed with the mills and shops in the United States since the first of January have aggregated \$321,200,000, of which \$143,000,000 is for cars, \$125,200,000 for locomotives, \$50,000,000 for rails, and the balance for bridges, terminal work and for track supplies. The making of this equipment has caused a draft upon the steel mills for 2,518,000 tons of steel. Of this total 1,113,000 tons will be rolled into rails, 718,000 tons into bars, plates and shapes for cars, 500,000 tons into forgings, castings and rolled shapes for locomotives, and the balance into structural shapes for bridges and into various forms for track supplies. During the corresponding period last year similar orders called for 4,000,000 tons of steel products, of which 2,733,000 tons were for rails. Aside from rails, 1,271,000 tons went into the manufacture of cars, motive power, bridges and track supplies. Rail contracts

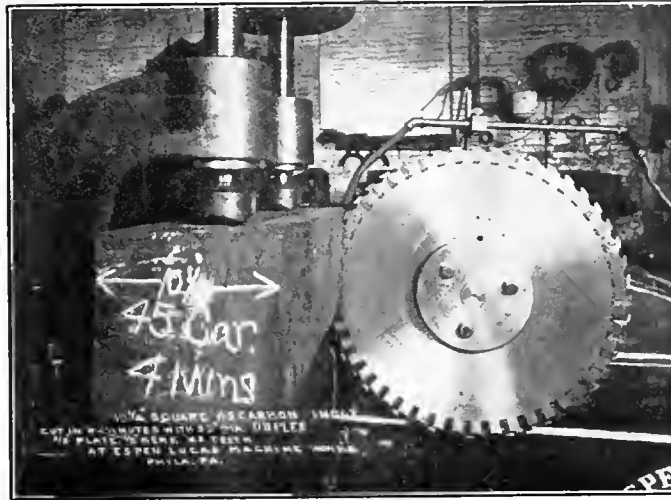

Circular Metal Cutting Saw Blades for Any Type of Machine

Let us demonstrate what a saving can be made by installing a **HUNTER "DUPLEX" Inserted Tooth Blade**

Write for information
HUNTER SAW & MACHINE CO., Pittsburgh, Pa., U.S.A.

PATENT ATTORNEYS

BABCOCK & SONS

ESTAB. 1877
PATENTS-TRADE MARK-DESIGNS
IN ALL COUNTRIES

Book "Patent Protection"—free. Master of Patent Laws, Formerly Patent Office Examiner.
99 St. James St., Montreal, Que.
Branches: Ottawa, Washington.

RESEARCH BUREAU

REPORTS BY EXPERTS ON SCIENTIFIC, TECHNICAL AND INDUSTRIAL DEVELOPMENT.

SPECIAL RESEARCHES ARRANGED.

PATENTS, TRADE MARKS, ETC.

HANBURY A. BUDDEN CABLE ADDRESS "BREVET"
712 DRUMMOND BLDG., MONTREAL

PATENTS
Fetherstonhaugh & Co.,
Patent Solicitors, Head Office,
Royal Bank Bldg., Toronto.
Ottawa Office, 5 Elgin St.
Send for our Plain Practical
Pointers. Copy of National
Progress, in which our patents
are advertised, mailed free.

PATENTS PROMPTLY SECURED

In all countries. Ask for our Investor's Adviser, which will be sent free.

MARION & MARION 364 University St.
Merchants Bank Building, corner
St. Catherine St., MONTREAL, Phone Up. 6174
and Washington, D.C., U.S.A.

MORTON MANUFACTURING CO.
PORTABLE PLANERS
DRAW CUT SHAPERS
SPECIAL DRAW CUT R SHAPERS
FINISHED MACHINE KEYS
STATIONARY & PORTABLE KEY WAY CUTTERS
SPECIAL LOCOMOTIVE CYLINDER PLANERS
OFFICE—WORKS: MUSKEGON HEIGHTS U.S.A.

The Costliness of Man-time

HOWEVER necessary it may be to employ flesh and blood salesmen to sell your merchandise to farmers, you cannot possibly overtake all your prospects by this method alone. It would bankrupt you.

You must employ the method of influence and persuasion known as Modern Advertising. By this means you can make known what you have to sell to all farmers everywhere, simultaneously.

Suppose you cannot afford to use all the farm papers, and are looking for one having national circulation. This one medium is

The FARMER'S MAGAZINE

This should impress you: The Farmer's Magazine is the best produced farm paper in Canada—3-color covers, fine illustrations, good paper, good typography and printing, and most important of all, the best edited. A sample copy will convince you.

If the farmer is your customer, use The Farmer's Magazine.

N.B.—Objectionable advertising not accepted. Both editorial and advertising columns are closely censored to keep them clean and decent.

Published by
The MacLean Publishing Co., Limited
143-153 University Avenue, Toronto, Ontario

THE IRON WORKS
LIMITED

Successors to

Owen Sound Iron Works
Owen Sound, Ont.
Engineers
Boiler-makers
Founders
Machinists

Tank Work
Smoke Stacks,
Grey Iron and
Brass Castings,
Special
Machinery
Made to
Order

 **"Barnes-made" SPRINGS**

are the result of over sixty years' experience in spring making, combined with unsurpassed equipment and the workmanship of men who have been with us, ten, twenty and in some cases thirty years.

Write for booklet No. 7-T.

Established 1852.
THE WALLACE BARNES COMPANY
218 South St., Bristol, Ct., U.S.A.
Mfrs of "Barnes-made" Products
Springs, Screw Machine Products, Cold Rolled Steel and Wire

METAL STAMPINGS

We are manufacturers of stamped parts for other manufacturers.

We do any kind of sheet metal stamping that you require. Our improved presses and plating plant enable us to produce the finest quality of work in a surprisingly short time.

We can finish steel stamping in Nickel, Brass or Copper.

Send us a sample order.

W. H. BANFIELD & SONS
372 Pape Avenue, Toronto, Can.

since January 1, this year, have been less than one-half of the orders placed in the first five months of 1916, but the 1,404,000 tonnage that went into other equipment this year was 110,000 tons greater than was needed in 1916.

TENDERS

Swift Current, Sask.—Tenders will be received until June 19, by the City of Swift Current, for one Motor-Driven Centrifugal Pump having a capacity of 800 Imperial gallons per minute against a 300 ft. head. Geo. D. Arnott, City Clerk.

Toronto, Ont.—Tenders addressed to the Secretary-Treasurer of the Board of Education, will be received until June 14, for midsummer repairs sundry schools, in the following trades:—Steam-fitting, electrical work, ash hoists, etc. Specifications may be seen and all information obtained at the office of the Superintendent of Buildings, Administration building, 155 College St.

INCORPORATIONS

The McTavish Motor Co., of Calgary, Alta., has been incorporated with a capital of \$20,000.

Winnipeg, Man.—The Waterloo Boy Kerosene Tractor of Canada, has been incorporated with a capital stock of \$20,000 by W. F. Rondabush, C. A. Sargent, E. P. Hayden and others to manufacture tractors, farm implements, tools, etc.

Beaverton Tcy Co. has been incorporated at Toronto with a capital of \$40,000 to manufacture toys, etc., at Beaverton, Ont. The provisional directors are B. Madill, Mr. Shapiro and A. Cooperman all of Beaverton, Ont.

Waterbury Chemical Co. of Canada, Ltd., has been incorporated at Toronto, with a capital of \$125,000 to manufacture chemicals and drugs etc., of all kinds at Toronto. The provisional directors are J. R. O'Connor, Allan A. Bain and L. A. Bayes all of Toronto.

Hudson Bay Knitting Co., has been incorporated at Ottawa with a capital of \$500,000 to manufacture cotton, woolen and linen goods, etc., of all kinds. Head office is at Montreal and the incorporators are T. B. Gould, F. P. Brins and A. Savard all of Montreal.

Fabri-Cord Tire Co., of Canada, Ltd., has been incorporated at Ottawa with a capital of \$1,500,000 to manufacture rubber and gutta-percha goods of all kinds. Head office is at Toronto and the incorporators are A. L. Reid, K. D. Mackenzie and A. MacBorthwick, all of Toronto.

The Foundation Co., of British Columbia, Ltd., has been incorporated at Ottawa with a capital of \$30,000 to carry on a construction business. The head office is at Montreal and the incorporators are G. W. MacDougall, W. B. Scott and J. Macnaughton all of Montreal.

Ker Woodturning Co., has been incorporated at Toronto with a capital of

\$40,000 to carry on the business of woodturning and operating in woods of all kinds. The head office is in Toronto and the provisional directors are Thomas Ker, G. H. Harper and W. J. McWaters all of Toronto.

WOODWORKING

Victoria, B.C.—Damage estimated at about \$100,000 was done in a fire which broke out on June 8 at the Cameron Lumber Co's. mills near Selkirk Water. The planing mill, box factory and cross-arm factory, together with the greater part of the machine shop are included in the damage done by the outbreak, which is traced to a hot journal-box in one of the machines. A small insurance was carried.

RAILWAYS—BRIDGES

Vancouver, B.C.—The new Great Northern and Canadian Northern Pacific union depot was thrown open to the public on June 2.

Stratford, Ont.—The Bridges and Roads Committee of the Perth County Council has recommended that all the county bridges out of order be repaired.

Simcoe, Ont.—A deputation from Port Dover asked the County Council for the rebuilding of the swinging bridge over the mouth of the Lynn River there.

Winnipeg, Man.—In a few weeks a start will be made on the construction of the new 700-foot bridge to be built over the Red river connecting Winnipeg with St. Boniface from the foot of Provencher avenue. The Dominion Bridge Co. has the contract to "deliver a completed bridge for \$241,000," with two piers that will hold the machinery for the movable spans, and which will have to be raised six feet above their present level. The cost of the structure is being borne jointly by the city of Winnipeg and St. Boniface, the city of Winnipeg to provide the electric power for the spans, machinery and lighting.

CONTRACTS

Oshawa, Ont.—The Town Council have accepted the tender of the John Ver Mehr Engineering Co., of Toronto, for the installation of a filtration plant.

Sudbury, Ont.—The Town Council has awarded a contract for a standpipe to the Chicago Bridge & Iron Co., of Bridgeburg, Ont., for \$31,065.

Oshawa, Ont.—The Town Council have awarded a contract to the Turbine Equipment Co., Toronto, for one 6-inch 2 stage, De Laval centrifugal pump, to have 1½ million gals. a day against 340 ft. total head, and to be direct connected to 150 h.p. motor.

MARINE

The Halifax Shipbuilding Co., with a capital stock of three million dollars and head offices at Halifax, N.S., has been Federally incorporated. The provisional directors are given as members of a Halifax law firm.

Halifax, N.S.—The Canadian steamer Premier, while coming out of Sambro, in a fog, on June 4, went ashore on Pólock Ledges, and is still hard and fast aground. The crew was taken off by steamers that went to her assistance. The vessel registered 275 tons, and was formerly owned in Toronto.

New Glasgow, N.S.—The first steamer to be built by the Novt Scotia Steel & Coal Co., will be ready to launch in three or four weeks. Work on the second steamer, which is 25 per cent. larger than the first, is well advanced, and as soon as the first is launched the keel of a third will be laid.

Carried Record Cargo.—When the steamer W. Grant Morden left Port Arthur, early this month, she carried the largest cargo of oats which has left the head of the lakes. There were 765,000 bushels of oats in her holds. The Morden is the largest freighter on the lakes, and was built at the Port Arthur ship-building plant.

St. Catharines, Ont.—A rather rare event occurred on June 7, when the steamer Schuykill, which for a number of years has been engaged in freight service on the Great-Lakes, passed through the Welland Canal in two parts. She was cut in two sections in a Buffalo dry dock, and will again be joined in Quebec prior to going into service on the Atlantic.

Anchor, Donaldson, Ltd.—In connection with the recent formation of Anchor, Donaldson, Ltd., announced in the Lloyd's list, the Donaldson Line management explain that the new company has acquired the steamers Letitia, Saturnia, Cassandra and Athenia. Otherwise the Donaldson Line continues as before, managed by the Donaldson Brothers, Ltd., and there is no prospect of further change.

Schooner "McClure" Torpedoed.—Private advices announce that the three-masted schooner McClure, formerly owned and sailed by Captain Isaac A. Hopkins, of Halifax, has been torpedoed in the Mediterranean. Captain Augustus Taylor and crew are safe. The McClure was sold by Captain Hopkins to G. A. Taylor, of St. John's, Nfld., and Capt. Taylor and crew came to Halifax last winter and took the vessel to St. John's with a general cargo. On this trip the McClure had a cargo of fish from St. John's. She was a vessel of 191 tons register.

Lakes All Higher in May.—Each of the Great Lakes attained a higher level in May than in April, and with the exception of Lake Ontario, each was above the average for the month in the past ten years, according to the monthly report issued by the United States Lake Survey Office at Detroit, Mich., on June 7. The stages of each of the lakes in feet above mean sea level in May, as compared with April, were:—

	April.	May.
Superior	602.28	602.38
Michigan-Huron ..	580.78	581.14
St. Clair	575.21	576.07
Erie	572.57	572.93
Ontario	246.24	246.51

**"HAWK"
CHROME
VANADIUM
STEEL**



Will
Give You
Exceptional

**Shell Forging
Production**

**WITHOUT AN EQUAL FOR
BOTH FIRST AND
SECOND OPERATION
PUNCHES.**

Comes to you heat-treated and ready for use.

It does not stick to the work.

There are many cases where each punch has turned out over 2,000 shells.

It means more shells, per machine per day.

**STEEL OF EVERY
DESCRIPTION.**

**Hawkrige Brothers
Company**

303 Congress St., BOSTON, MASS.
U. S. A.

**TRY HAMILTON
BABBITTS**

We Make Nothing Else
GEO. E. JOBBORN, Hamilton, Ont.

Cameron Babbitt Retainer

(Patented in Canada and the U.S.A.)

Not like clay or other material, as it does not stick to the work or hands. Does away with using leather or paste-board at end of box.

The only satisfactory compound for retaining molten metal and can be used over and over again for months—no deterioration.

For any metal.

For prices and samples apply to

A.S.K. Chemical Company, Elora, Ontario

I BELIEVE

*In Safety First and always.
In providing for the Health of my Fellow
Workmen.
In Light and Air and sanitary Working Con-
ditions.
In clean, fresh drinking water for everybody.
In the Safety, Economy and Man-betterment.*

PURO SANITARY
DRINKING
FOUNTAIN

(MADE IN CANADA)

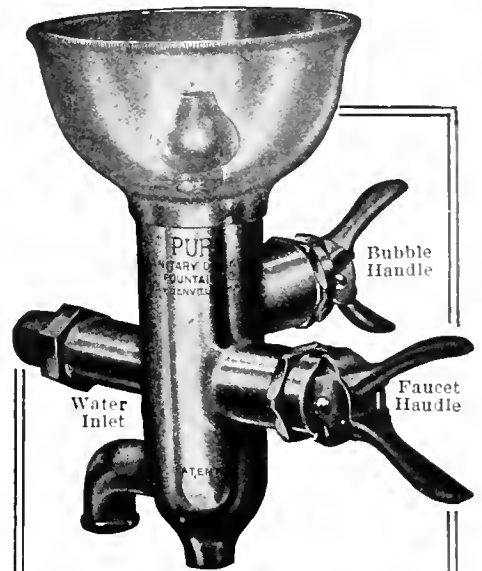

The loss of a man through impure drinking water is a crime that "the front office" must bear.

An ugly statement, isn't it? But true, absolutely.

When a man comes to work in your factory he puts his health in your keeping.

Are you willing to take chances on such a trust?

Impure drinking conditions are responsible for more tragedies than any machine ever built.

Apply the "Safety First" Principles to your water supply; don't deny your men a clean, fresh drink of water.

Conserve their health and they will improve your profits; make yourself as worthy of the name of "employer."

Install the Gold Medal winner Puro in your plant, office and shop alike.

The only Sanitary Drinking Fountain that is safe, sanitary, simple, automatic in control and easily attached.

Let us tell you just what it will cost you to

"PURO - FY"

YOUR WATER SUPPLY

Puro Sanitary Drinking Fountain Company
147 University Ave., Toronto, Canada

OVENS

Enameling and Varnishing Ovens heated by Gas, Electricity, Steam or Coal. Write for Booklet.

Brantford Oven & Rook Co., Ltd.
Brantford, Canada.

Cameron Babbitt Retainer

(Patented in Canada and the U.S.A.)

Not like clay or other material, as it does not stick to the work or hands. Does away with using leather or paste-board at end of box.

The only satisfactory compound for retaining molten metal and can be used over and over again for months—no deterioration.

For any metal.

For prices and samples apply to

A.S.K. Chemical Company, Elora, Ontario

CLASSIFIED ADVERTISING

Rates (payable in advance): Two cents per word first insertion; one cent per word subsequent insertions. Count five words when box number is required. Each figure counts as one word. Minimum order \$1.00. Display rates on application.

SECTION

FOR SALE

FOR SALE — 1 HOLDEN-MORGAN BASE milling machine, 3-inch shell, Manitoba Bridge & Iron Works, Winnipeg.

FOR SALE—ONE LEWIS TYPE ENGINE built by Waterous Engine Works, 240 H.P., flywheel 73" x 18", automatic governor, a bargain. One steam pump, 4½" x 2¾" x 4". Write Box 217, Montreal, N.B. c24m

ONE—50 K.W., 220 VOLT, D.C. PEERLESS Self-oiling, Automatic Engine, with Switch-board complete. Two, 10 H.P., D.C., 220 volts motor; one 20 H.P., D.C., 220 volts motor; one feed-water heater and purifier 36" x 12".—The American Motor Sales, Chatham, Ont. c24m

TWO NEW BOILERS, 66" x 16', FOR SALE, immediate shipment. One smoke stack, 54" x 80', also one C.G.E. generator, 62.5 K.V.A. with exciter and switchboard. Box 312, Canadian Machinery. (c24m)

ONE LATHE 16" x 4½' BACK-GEARED — Built by P. P. Silk Machine & Tool Co., Cincinnati, Ohio. One lathe 18" x 3', back-geared. Built by the Bradford Mill Co., Cincinnati, Ohio. Four Murchey collapsible dies. Capacity 1½" to 2½". Box 272, Canadian Machinery. ctmf

FOR SALE—TWO 16 x 6 REED PRENTICE Automatic Lathes. One Bertram Gap Lathe, 48 x 10. Four No. 10 Heavy Duty Baker Drills. One No. 2D Colburne Drill. One Heavy Duty Reliance Machine Co. Turret Lathe for inside boring of 6" shells. Canadian Blower & Forge Co., Kitchener, Ont. c24m

WE HAVE ON HAND AT OUR WELLAND Works, for disposal, the following new machinery:—One (1) 18" x 15 ft. Accumulator; one (1) Aldrich Triplex Hydraulic Pump, 180 gals. capacity; two (2) 350-ton B. and B. Presses. All offers will be carefully considered. Canadian Car & Foundry Co., Ltd., Transportation Building, Montreal.

THE NATIONAL MANUFACTURING COMPANY, Limited, Ottawa, have the following machine tools for sale:—1 25-ft. Westinghouse Air Compressor, with Receiver; 1 20" Drill Press; 1 4-spindle 12" Drill Press, Cincinnati Pulley & Machine Co.; 1 Canadian Blower & Forge Co., 21" Drill Press; 2 Racine Power Hack Saws; 1 McKechnie Bertram Planer, 36" x 36" x 10' 0" bed; 1 Wagner Motor, 10 H.P., 2-Phase, 60 Cycles, 440 Volts, 1140 R.P.M., complete with starting base; 1 Barnes 21" Drill Press; 5 Simplex Lathes, never used; 2 Ford-Smith Grinders, suitable for 18-pdr. Shrapnel Shell; 2 Thread Millers for 18-pdr. Shrapnel, in need of repairs; 3 Shrapnel Furnaces; 1 Turret Lathe. c23m

1—ROBB HORIZONTAL STEAM ENGINE, 10 x 12, 35 h.p. Just overhauled by makers. Price \$300.00. 1—Heavy Duty Rockford Drill, Suitable for shells or heavy work. Weight of drill 3,600 lbs. Good as new. Write for specification. 1—Jones & Lamson 2 x 24 Turret Lathe, 2¼" hole in spindle, 16" swing, cone drive, collet chucks for bars up to 2" diameter. Or lathe can be fitted with standard universal chuck. Flat turret 16" diameter. Good condition. Price \$400.00. 1—Warner & Swasey Turret Lathe. Round turret, diameter 8", hand cross feed for turret Swing 14". Fairly good condition. Price \$200.00. 1—Bertram 2-spindle Thread Miller. Made by makers for threading 18-pdr. shells. Now used for threading sockets. Good condition. Steel Furnishing Co., Ltd., New Glasgow, Nova Scotia. c2m

BUSINESS CHANCES

SHELL PLANT FOR SALE — COMPLETE plant installed since 1914, for the machining and assembling of 4.5 inch H.E. shells, situated at Dartmouth, Nova Scotia, on line of Intercolonial Railway, with siding running into the works. Will sell the equipment outright, with privilege of renting the building in event of the purchaser engaging in the same business. Starr Manufacturing Co., Limited, Dartmouth, Nova Scotia, Canada. c26m

FOR SALE—A MEDIUM-SIZED TWO-STOREY brick factory situated in the best small city in Ontario. Buildings in good condition, suitable for either metal or wood-working; shipping facilities unexcelled. Two trunk lines; direct connections east, west, north and south. Educational advantages the very best. Plant will be sold at a bargain and on easy terms of payment, if desired. Apply Box 294, Canadian Machinery. c2m

AGENCIES WANTED

AGENTS HAVING CONNECTION WITH large workshops factories in mechanical construction business and dealing in tools and tool outputs, wish to represent in France a good house manufacturing especially Lathes, Drills, Files, Vises, Tinware, Machinery, Tool Outputs, etc. Good references. Address Hoon & Barronnet, 11 Rue Bichet, Paris. c24m

SPECIAL MACHINERY

MANUFACTURERS—WE CAN UNDERTAKE work to any specification—munition production equipment or otherwise. Write W. H. Sumbling Machinery Co., 7 St. Mary St., Toronto.

S. VESSOT & CO., GENERAL MACHINE SHOP and Grey Iron Foundry. We can undertake at present time light machining and grey iron castings, at reasonable prices. Address Joliette, Que. c1m

"Moving pretty good, eh?"

After two insertions of their half-column ad on used equipment, three items were cut out. After two more several more were omitted. No wonder the advertiser said: "Moving pretty good, eh?" And they go on to say: "We feel we have been pretty successful in removing this second-hand equipment so readily." You can do the same. Let an ad in Canadian Machinery help you do it.

Canadian Machinery
Classified Advertising Section
143 University Ave., Toronto, Ont.

SITUATIONS WANTED

HIGH-GRADE MAN, EXPERIENCED IN General construction, manufacturing, machine shop work and heavy shells, is open for a good offer only. Box 315, Canadian Machinery. c25m

PRACTICAL WORKS MANAGER AND Mechanical expert with years of experience in United States and Canada, a specialist in munition work, open for engagement. Best of references. Apply Box 304, Canadian Machinery. c4m

ELECTRICAL ENGINEER—COLLEGE GRADUATE, five years' practical experience; now employed in large industrial plant, electric-driven; responsible position desired; money not sole object; recommendations. Box 305, Canadian Machinery. c26m

WANTED—POSITIONS FOR THOROUGH Mechanics, Toolmakers, Toolsetters, Grinders, Fitters, Automatic Operators, General Foremen, Chief Munition Inspectors; positions for soldiers deprived of limb, if hands whole, for table work inspecting, etc.; also for female artisans of all kinds, viz., Munition Inspectors, Operators, Superintendents, Timekeepers and Female Elevator attendants tall, age over thirty; matrons. Employers send to "Toronto Engineering Agency," 57 Queen W., Toronto, Adel. 809. c24m

SITUATIONS VACANT

WANTED—TOOL MAKERS TO WORK ON munitions. Apply at once. Wallaceburg Brass & Iron Mfg. Co., Ltd., Wallaceburg, Ontario. c25m

THOROUGHLY CAPABLE BRASS FOUNDRY Foreman to take charge of small foundry doing a general jobbing business and also munition work. Location Montreal. Address for information, "Brass Foreman," P.O. Box 1934, Montreal. c26m

WANTED—TWO EXPERIENCED BORING lathe hands to take charge on day and night shifts, of battery of boring lathes for 6" Mark III shell. Only men who can get good bores and high production need apply. Give in the first instance, experience, wages required and full particulars, otherwise application will not be considered. Box 317, Canadian Machinery. c26m

HOISTING MACHINERY SALESMAN, BETWEEN ages of 30 and 40; prefer, if possible, man having experience machine shop, drafting room, general office, as well as actual selling. Man of sound training and good judgment assured steadily increasing salary and good future. Reply giving all needful information in few words, to Box No. 318, Canadian Machinery. c25m

6" SHELL FOREMAN WANTED WITH Special qualifications to get production from shop at Peterborough, Ont., which has been running on 6" shell for eighteen months. Tooling and shop inspection separately organized. Foreman to give his whole attention to obtaining maximum production. Give full particulars in first application as to previous experience, references, and salary required, otherwise application will not be considered. Apply to Box 316, Canadian Machinery. c25m

CANADIAN MACHINERY

AND MANUFACTURING NEWS

A weekly newspaper devoted to the machinery and manufacturing interests.

Vol. XVII.

TORONTO, JUNE 21, 1917

No. 25

EDITORIAL CONTENTS

Fisheries Protection Vessels Launched at Toronto	641-644
General	644
Montreal Interests Acquire Wood Shipbuilding Plant.	
Production Methods and Devices	645-647
Special Circular Turning Tool....Pulley Turning Rig....Shell Handling Device....	
Special Patented Roller Chuck.	
Canadian Manufacturers' Association Convention	648-651
Presidential Address by Col. Thos. Cantley....Synopsis of Proceedings.	
Contemporary War Articles	652-653
Metric System, its Meaning for the Machine Shop.	
General	653-654
Dominion Steel Corporation Annual Meeting....Canadian Government Railways Statement.	
Metal Planers, and Methods of Production Employed	655-657
General	657-658
Iron and Steel in Canada, 1917....Electrical Drive for Rolling Mills....Probability of Shop Building Standardization.	
Progress in New Equipment	659
12-inch Rotary Surface Grinding Machine. Automatic Tapper and Bench Drill	
....13-inch Engine Lathe....Automatic Multiple Plunger Press.	
Editorial	662
Manning a Canadian Mercantile Marine....The Outlook.	
Industrial Notabilities	664
S. R. Parsons.	
Selected Market Quotations	664-665
The General Market Condition and Tendency	665-668
Montreal Letter....Toronto Letter....Sydney Letter....Pittsburgh Letter	
Industrial and Construction News	669-670

THE MACLEAN PUBLISHING COMPANY, LIMITED

JOHN BAYNE MACLEAN, Pres. H. T. HUNTER, Vice-pres. H. V. TYRRELL, Gen. Man.

Publishers of Hardware and Metal, The Financial Post, MacLean's Magazine, Farmer's Magazine, Canadian Grocer, Dry Goods Review, Men's Wear Review, Printer and Publisher, Bookseller and Stationer, Canadian Machinery and Manufacturing News, The Power House, The Sanitary Engineer, Canadian Foundryman, Marine Marine Engineering of Canada.

Cable Address: Macpubco, Toronto; Atabek, London, Eng.

ESTABLISHED 1887

CANADIAN MACHINERY

AND MANUFACTURING NEWS

PETER BAIN, M.E., Editor. B. G. NEWTON, Manager
Associate Editors: A. G. WEBSTER, J. M. WILSON, J. H. RODGERS.

CHIEF OFFICES:

CANADA—Montreal, Southam Building, 128 Bleury Street, Telephone 1901, Toronto, 113-153 University Ave., Telephone Main 7321; Winnipeg, 22 Royal Bank Building, Telephone Garry 2313.

GREAT BRITAIN—LONDON, The MacLean Company of Great Britain, Limited, 88 Fleet Street, E.C., E. J. Dodd, Director, Telephone Central 12960. Cable Address: Atabek, London, England.

UNITED STATES—New York, R. R. Huestis, Room 629, 111 Broadway, N.Y., Telephone Rector 8971, Boston, C. I. Morton, Room 733, Old South Building, Telephone Main 1291, A. H. Byrne, 1101-5-6-7 Fort Dearborn Bldg., 105 W. Monroe St., Chicago, Telephone Randolph 3239.

SUBSCRIPTION PRICE—Canada, Great Britain, South Africa and the West Indies, \$3.00 a year, United States, \$3.50 a year; other countries, \$4.00 a year. Single Copies, 15 cents. Invariably in advance.

Anybody Can Operate This Miller and Turn Out a Pile of Work So Simple to Operate is the "HENDEY"

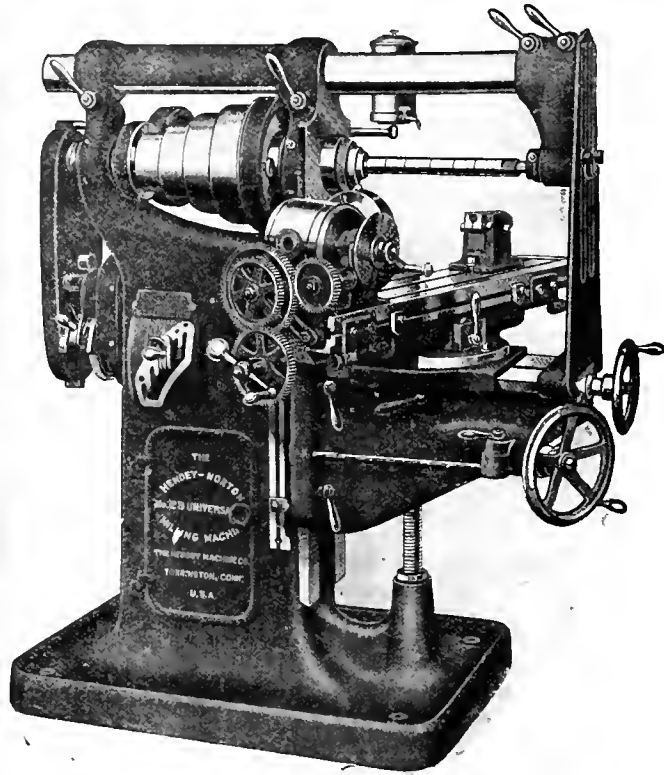

Skilled mechanics are scarce these days—but anyone can run a machine of its simplicity and turn out work accurately and fast without trouble.

All Feeds positive driven through gearings giving 18 changes.

This is the universal type—designed to handle all milling operations performed on machines of this character, either with regular equipment or by aid of attachments, which can be supplied for increasing efficiency and scope of machine.

Write for full description.

The Hendey Machine Co. Torrington, Conn., U.S.A.

Canadian Agents: A. R. Williams Machinery Co., Toronto, Ont.; A. R. Williams Machinery Co., 260 Princess St., Winnipeg; A. R. Williams Machinery Co., Vancouver; A. R. Williams Machinery Co., St. John, N.B.; Williams & Wilson, Montreal.

INDEX TO ADVERTISERS

Adams, Ogden R.	102	Deloro Smelting & Refining Co.	6	Lambie Machine Co.	13	Richmond Mfg. Co.	97
Armstrong Bros. Tool Co.	98	De Mooy Mach. Co.	12	Lanashire Dynamo & Motor Co.	83	Rover-Shafer Co.	17
Armstrong, Whitworth & Canada.	12	Diamond Saw & Stamping Works.	89	Lattone Electric Steel Co.	14	Riverside Machy. Depot.	74
Atkins, Wm., & Co., Ltd.	13	Dominion Forge & Stamping.	94	Lynn-Farquhar Co.	71	Rivett Lathie & Grier Co.	118
		Dominion Machinery Co.	73	M.		Rofelson Machine & Tool Co.	17
		Dominion Steel Foundry Co.	99	MacKinnon, Holmes & Co., Ltd.	67	Rojet & Co., C. F.	95
				M.			
Babeck & Sons	67			M.		S.	
Bald Machine Co.	132	Eastern Mach. Screw Corp.	95	Manufacturers Equipment Co.	96	Sinclair Co., E. B.	102
Balfour, E. J.	11	Elmes, Chas. F.	24	Marion & Marion	67	Sidney Tool Co.	19
Balfour, W. H., & Sons	67	Eric Foundry Co.	24	Marsh & Henthorn, Ltd.	117	Silver Mill Co.	101
Barnes, Wallace, Co.	67			Mathews, Jas. H., & Co., Inc.	30	Simmons Mach. Co.	56, 109
Bath, Cyril J.	74			McCarthy & Sons, T.	73	Skinner Chuck Co.	99
Baxter & Co., Ltd., J. R.	15	Fairley, Davidson Steel Co.	12	McGee, J. J.	22	Sheper & Hartley, Inc.	97
Beatty & Son, M.	75	Fetherstonhaugh & Co.	6	McGowan-Brandt Machy. Co.	75	Standard Alloys Co.	9
Bertram, John, & Sons Co., Ltd.	1	Fitchburg Grinding & Mach. Co.	115	McDougall Co., H.	Inside back cover	Starratt Co., L. S.	26
Bilton Mach. Tool Co.	20	Fitzgerald, W. H. J.	74	McLaren, J. C., Belting Co.	123	Steel Bending Brake Works, Ltd.	100
Blake & Johnson Co.	111	Ford-Smith Mach. Co.	21	Mechanical Engineering Co.	94	Steel Co. of Canada	3
Blount, J. G.	15	Foss & Hill Machy. Co.		Metal Manufacturers' Service	78	Steptoe, John, Co.	82
Bradford Oven & Rack Co.	66		Inside back cover	Metalwood Mfg. Co.	25	Stocker-Brimley-Wachs Co.	72
Bradford Mach. & Tool Works.	5	Francis & Co.	191	Millers Falls Co.	57	Stow Mfg. Co.	111
Bristol Company	93			Monarch Brass Mfg. Co.	79	Strong, Kennard & Nutt Co., The.	102
Brownell Machy. Co.	71	Gardner Machine Co.	113	Montreal Machy. & Supplies	139	Summervant Co. of Can., Ltd., B. F.	86
Brown, Rogers Co.	11	Garlock-Walker Machy. Co.	75	Morse Twist Drill & Mach. Co.	15	Swedish Gage Co., Inc.	81
Brown's Copper & Brass Rolling Mills.	83	Garvin Machine Co.	18	Morton Mfg. Co.	7	Swedish Steel & Importing Co.	7
Budden, Handum A.	67	Geometric Tool Co.	69	Mottel & Neuyweather	78		
		Gibb Instrument Co.	50	Murphy Machine & Tool Co.	95		
		Gilbert & Barker Mfg. Co.	50			T.	
		Grant Gen. Works, Inc.	100	Napier Saw Works, Inc.	160	Taber Mfg. Co.	161
Canada Metal Co.	92	Grant Mfg. & Machine Co.	24	National Acme Co.	18	Tate-Jones & Co., Inc.	91
Can. Bond Hanger & Coupling Co.	93	Greenfield Machine Co.	161	National Machine Tool Co.	101	Taylor Instrument Co.	91
Canada Machinery Corporation				New Britain Mach Co.	19	T.C.M. Mfg. Co.	16
				New York Machinery Exchange.	56	Toronto Iron Works	99
				Nicholson Pipe	77	Toronto Testing Lab.	102
				Niles-Barnett-Paul, Inc.	102	Toronto Tool Co.	79
Can. R. K. Morton Co.	4	Noble & Westbrook	102	Nova Scotia Steel & Coal Co.	10	Trachon Pump Co.	25
Can. Bridge Co., Ltd.	75	Norton Crane Works	99				
Can. Fairbanks-Morse Co.	31	Norton, A. O.	109			U.	
Can. Desmoulin-Stephan Mfg. Co.	89	Norton Co.	32			United Hammer Co.	160
Can. Economic Lubricant Co.	93	Norton Grinding Co.	33			United States Electrical Tool Co.	70
Can. Ingersoll-Rand Co., Ltd.	115	Nova Scotia Steel & Coal Co.	10				
Can. Inspection & Testing Laboratories, Ltd.	99					V.	
Can. Metal Products	78					Vanadium-Alloys Steel.	Front cover
Can. Montreal Mfg. Co.	81					Vanland Crucible Steel Co.	10
Can. Steel Foundries, Ltd.	7						
Can. S. K. F. Co., Ltd.	29					W.	
Carbideum Co.	117					Walcott Lath Co.	49
Carlyle Johnson Mach. Co.	8					Warner & Swasey Co.	5
Chapman Double Ball Bearing Co.	93					Wells Bros. Co. of Canada	32
Cheimatt Iron & Steel Co.	19					Whiting Foundry Equipment Co.	94
Cheimatt Pulley Machy. Co.	107					Whitman & Barnes Mfg. Co.	88
Cleveland Pneumatic Tool Co.	91					Whitney Mfg. Co.	27
Cleveland Twist Drill Co.	107					Wickers Bros.	22
Clipper Belt Lacer Co.	92					Wilkinson & Kompess	161
Commercial Acetylene Welding Co.	24					Williams, A. R., Machinery Co.	65
Consolidated Press Co.	24					Williams & Co., J. H.	109
Cook, W. S.	101					Willson & Co., T. A.	179
Cullen Machy. Co., C. W.	74					Wilmath & Morman Co.	100
Cummings & Son, Ltd., J. W.	84					Windsor Mach. & Tool Works.	96
Curtis & Curtis Co.	88					Winfield Electric Welding Mach. Co.	101
Cushman Chuck Co.	99					Winning Gear & Engineering Co.	79
						Wing & Son, J. E.	81
						Wisconsin Electric Co.	117
						Wright Mfg. Co.	145
						Z.	
Devis-Bondeville Co.	130					Zenith Coal & Steel Products Co.	160
Davis, W. F., Machine Tool Co.	72						

Fisheries Protection Vessels Launched at Toronto

By C.T.R.

Some quite appreciable evidence of the activity which now marks shipbuilding and marine engineering in Canada has been made available by the launch from the Polson Iron Works, Toronto, in one afternoon, of four trim little craft for our fisheries protection service. The choice of names by which each vessel, including two others, will be known—"Ypres," "Messines," "St. Julien," "Vimy," "St. Eloi" and "Festubert," is a happy one, paying as it does a graceful compliment to our soldiers—the dead, the wounded, and the unscathed, all of whom covered themselves with glory in the six named victories over the Germans.

At intervals of from five to six minutes, beginning promptly at noon, Saturday, June 16, four out of six Canadian Government Fisheries Protection vessels under construction by the Polson Iron Works, Toronto, were released from the ways and transferred successfully to their native element in presence of several thousand spectators. The shipyard was gaily decorated with flags and bunting for the occasion, which was unique, in view of the fact that the quadruple launching is believed to be the

first of its kind to take place on this continent, or for that matter anywhere. Tastefully flag-draped stands were erected for the accommodation of the specially invited guests, and from which the christening ceremonies were performed by Mrs. Hugh McKay and Miss Athlea Hazen, daughters of the Hon. J. D. Hazen, Minister of Marine and Fisheries, who was also present. Prominent among the builder's specially invited launching party were to be noted Admiral Kings-

mill and J. C. Desbarats, of the Department of Naval Service, Ottawa; Col. Chambers, Chief Press Censor, Ottawa, who had been attending the Canadian Press Association Annual Convention; Mayor Church, H. A. Terrault, superintendent of construction, Ottawa; J. S. Irwin, Ottawa; Holt Gurney, T. A. Russell, R. R. E. Chisholm, Ottawa; Claude Macdonell, M.P.; Sir Frederick Stupart, T. H. Navin, Joseph E. Oliver, Captain James B. Foote, James Somers, George Gouinlock, W. J. McWhinney, K.C., Capt.

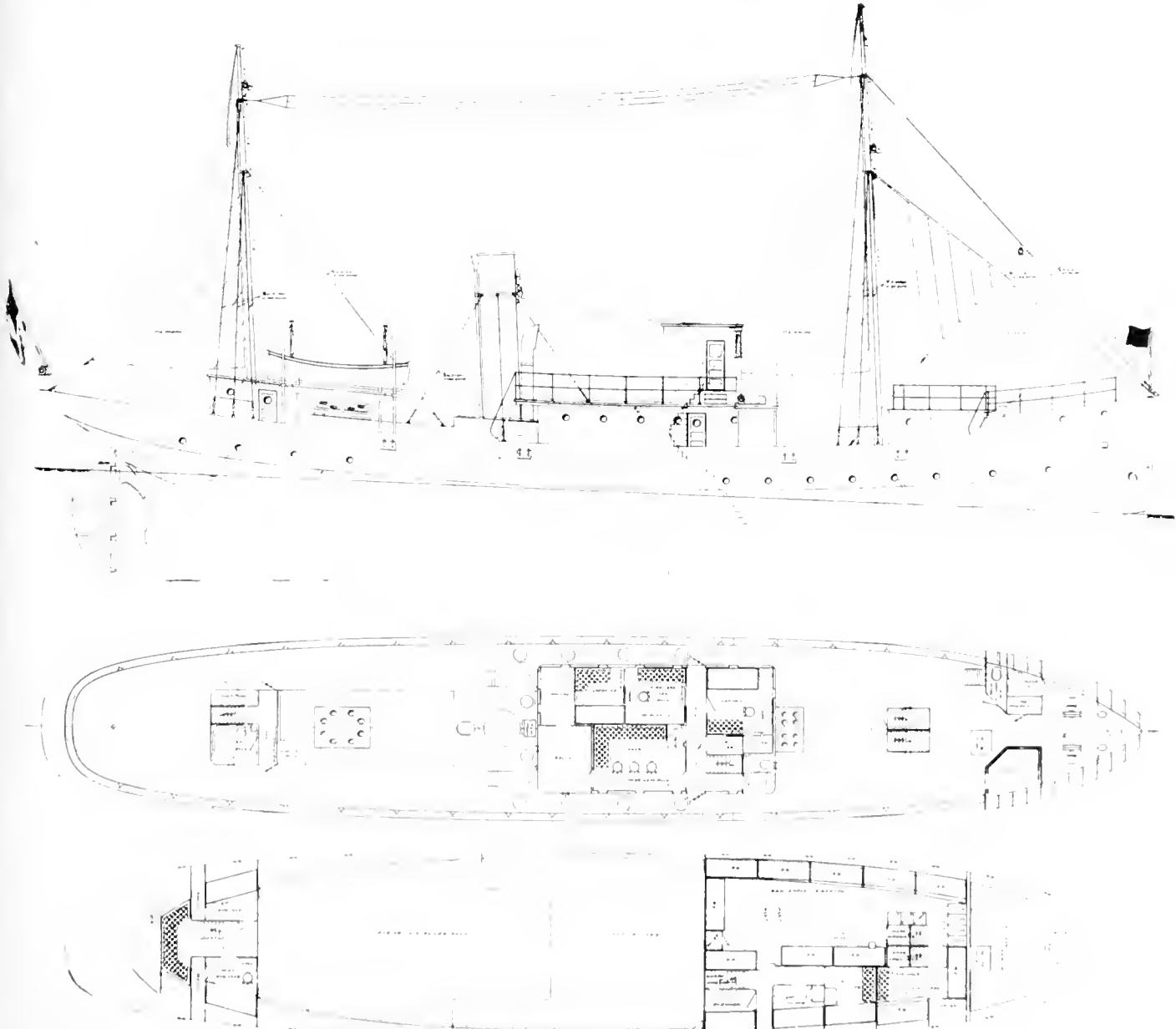

ACCOMMODATION AND RIGGING PLANS, FISHERIES PROTECTION VESSELS.

J. J. Manley, Port Arthur; Capt. E. Winthrop and Capt. Resfnes, representing Norwegian shipping interests; Lloyd Harris, Capt. Harry Miller, W. B. Tindall, Arthur Taylor, John Sharpe, Peter Bain, A. Guy Webster, and Geo. E. Pearson, of the MacLean Publishing Co.; Acton Burrows, of the Railway and Marine World, and many ladies. Mrs. McKay and Miss Hazen were each the recipient of a sheaf of roses by the firm.

Rapid Progress Made

Only some twelve weeks have elapsed since the keels of all six of the vessels were laid, and with four of them afloat—"Ypres," "Vimy," "Messines," and "St. Julien," and with the other two—"St. Eloi" and "Festubert," following suit in about fourteen days' time, it will be at once appreciated that the shipyard management, despite labor scarcity and the difficulty of procuring materials of construction promptly, are deserving of the highest commendation for their achievement. Further, when account is taken of the fact that two months of the specified time limit of completion for all six vessels has yet to run, and that the propell-

service on dates in every case ahead of requirement.

Guests and Employees Entertained

Following the launching ceremony, a buffet luncheon was served to the invited guests in a large marquee erected within the yard. At the same time refreshments and "smokes" were served to the firm's employees by the management in another section of the plant, a proceeding which was greatly enjoyed and which demonstrates the interest taken by the executive in its employees, and which the latter in turn reciprocate by whole-hearted honest effort.

Hon. J. D. Hazen's Speech

After full justice had been done to the hospitality provided, Col. J. B. Miller, president of the Polson Iron Works, introduced the Hon. Mr. Hazen, who gave a short address on the shipbuilding situation from the executive viewpoint, and from which we quote as follows:—

"The successful termination of the war will depend, to no small extent on the ability of the British Empire and our Allies to maintain sufficient shipping to carry on essential trades. The successes

that the losses to shipping, as the result of submarines and other enemy agencies, since the commencement of the war have been enormous, even although they have not nearly approximated the boastful expectations and predictions of the Germans. They have, nevertheless, been serious, totalling up to the end of April last about 5,811,100 tons. How stupendous this loss is, you will understand when I point out that the replacement value approximates, if it does not exceed, one thousand million dollars. Notwithstanding these enormous losses, there is the comforting thought that the construction of new ships has during the period of the war been well maintained, more especially by Great Britain and the United States.

Construction Combatting Destruction

"Without entering into any details, I may say that the total of the world's mercantile marine tonnage at the close of 1916 was 48,683,136 tons. Even if it so happens that the present ratio of destruction should be maintained for another year or, say, until the end of June, 1918, if we maintain the present ratio of

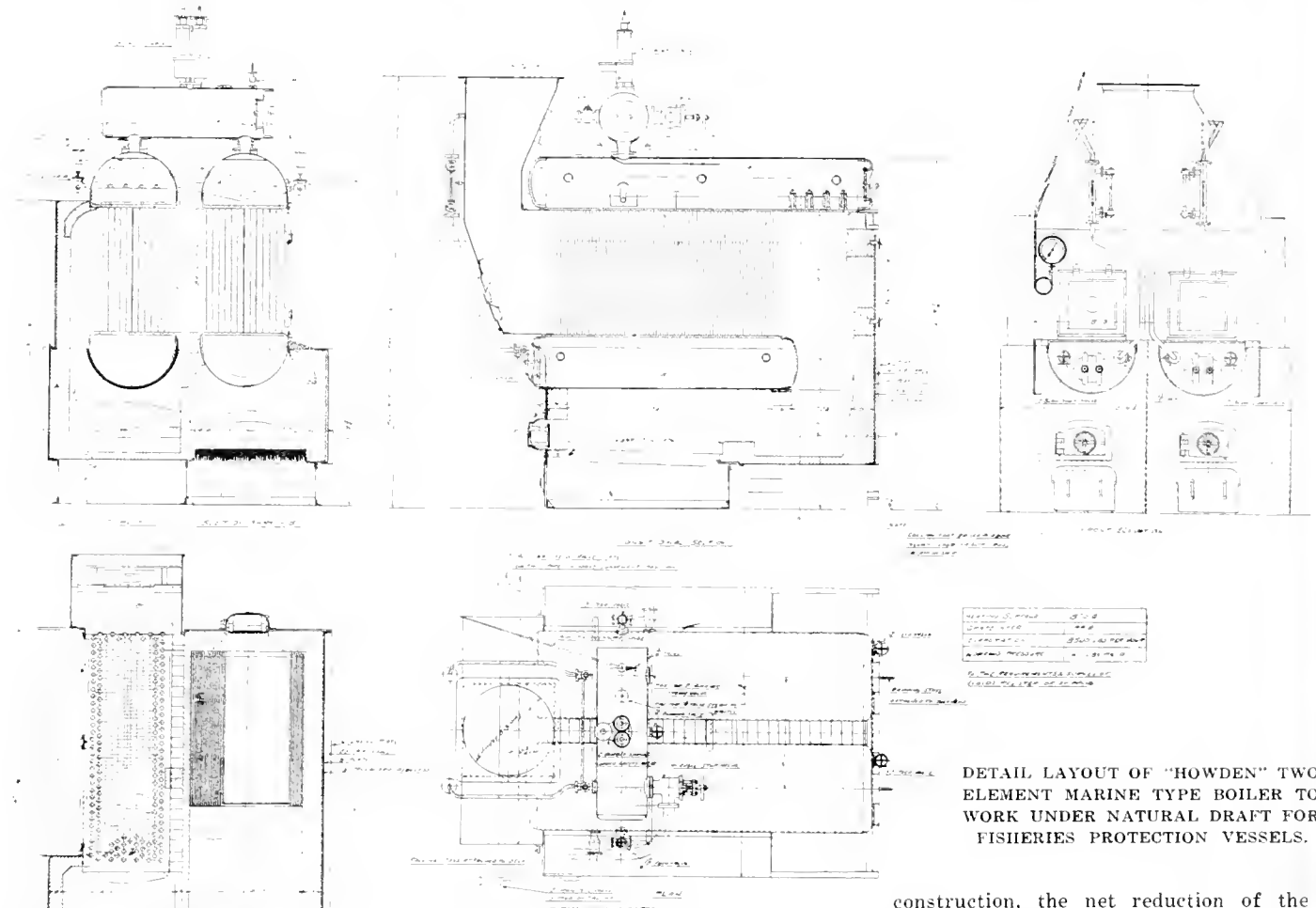

DETAIL LAYOUT OF "HOWDEN" TWO ELEMENT MARINE TYPE BOILER TO WORK UNDER NATURAL DRAFT FOR FISHERIES PROTECTION VESSELS.

ing and auxiliary machinery, together with the hull outfit equipment, are ready to instal, it may be readily forecast that every one of the little craft will be on

that we have achieved all along since the war commenced are due in no small measure to the efficiency of the British and Allied mercantile fleets.

"Lloyd George has said quite recently that one of the best ways of carrying on the war was by the production of ships and then more ships. Let me remind you

construction, the net reduction of the world's tonnage would be only about two per cent. Recent reports, however, go to show that there is no probability of the present ratio of destruction being maintained, and I ask your attention for a few moments while I submit a few facts as to what is being done in Canadian shipyards, to say nothing of the tremendous activity in ship construction in

Great Britain and the United States and in Japan, to establish that there is conclusive evidence that the ratio of construction will be more than maintained.

"There are at the present time under construction in Canadian shipyards merchant steamers totalling approximately 150,000 tons carrying capacity. The cost of producing this tonnage will be in the vicinity of \$25,000,000. In addition, there are building in various Canadian yards

there is also a bathroom and lavatory. On the main deck is located the galley with steward's and cook's room, also the officers' mess room and pantry. Above the cabin, forward, is the "Texas," embracing wheelhouse and chart room, wireless room, with operator's quarters in rear, and bridge opposite to door of the wheel house. Accomodation which includes a bath room for two engineers and second mate, is located aft below the

plate, rising 2 ft. 8 in. high above wood deck. Rolling chocks extend for a distance of 45 feet on each side of the vessel and are formed of 7 in. bulb bar, backed by 3½ by 9/20 in. angle. There are four freeing ports on each side fitted with strong hinged doors of the balanced type. Bulkheads are all of watertight construction. The two fresh water tanks are cement washed inside and have filling and air pipes, drain plug and hand

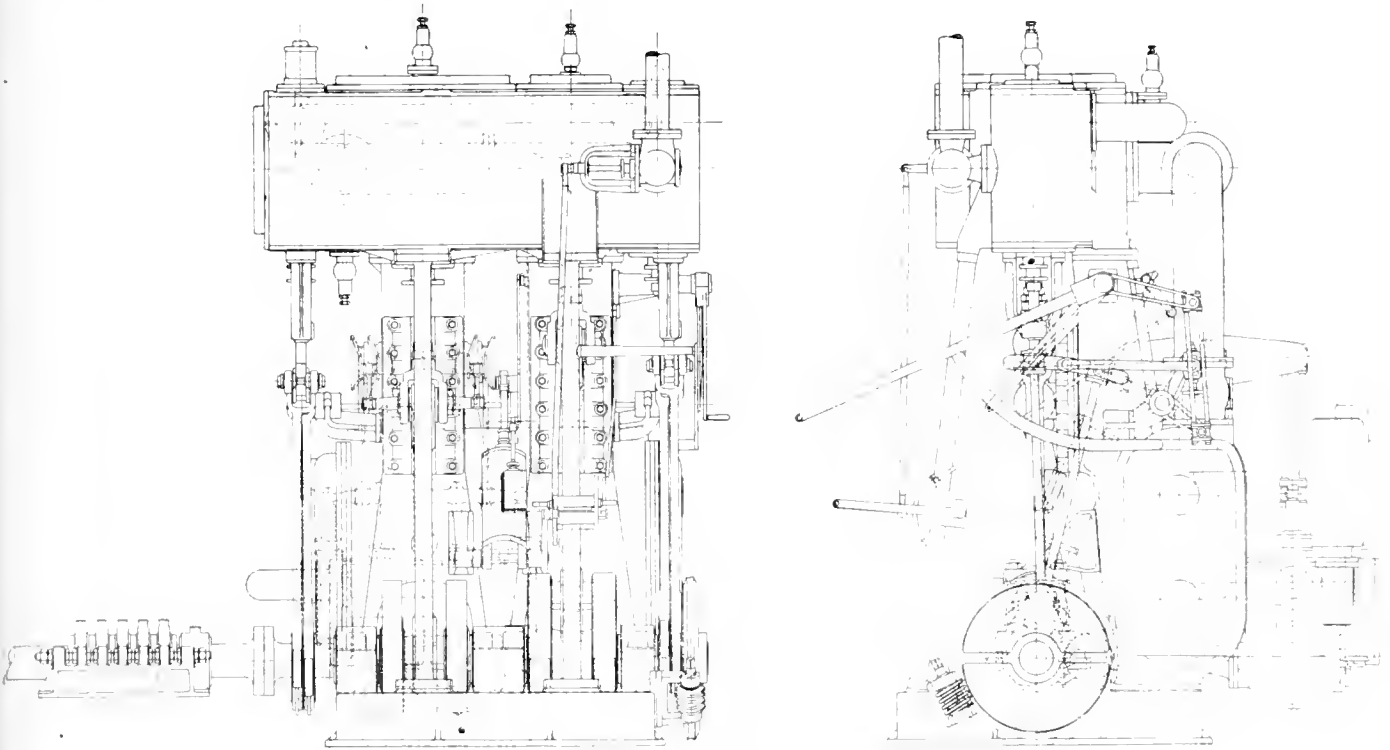

COMPOUND SURFACE CONDENSING ENGINES FOR FISHERIES PROTECTION VESSELS

wooden vessels aggregating a total carrying capacity of about 30,000 tons."

On the call of Col. Miller, three cheers were given the Minister of Marine and Fisheries for his presence and address. Mr. Hazen, in reply, called for three cheers for Col. Miller, Mr. Newman, the shipyard staff and employees generally, following which on his lead, three cheers and a tiger were given for the King.

Vessel Features

The vessels are constructed entirely of steel equal to Lloyds' requirements and have the following principal dimensions. Length between perpendiculars 135 feet; breadth extreme 23 feet 6 in.; moulded depth 13 feet 6 in., with deck beam camber of 7 inches. They are built on the deep frame system with ordinary floors throughout and have a straight stem and elliptical stern. The propelling machinery is located aft, the stokehold being at the forward end of the boiler with bunkers adjacent capable of holding 180 tons of coal. The crew's quarters as also their mess room and that for the petty officers are forward there being accomodation for eighteen men. The cabin which is situated on the main deck forward of the smoke stack, has separate state rooms for the captain, chief engineer and first mate while

main deck. Access is had from the main deck and also through a bulkhead from the engine room.

Constructional Details

The keel and stem are of mild steel 7½ in. by 1½ in., while the stern post is of cast steel equal to Lloyds' requirements. The rudder is of the single plate type, with arms shrunk and keyed on to post, and carrying four portable pintles. The top pintle is fitted with a locking device to prevent rudder from lifting. The frames are of the deep type consisting of 5 x 3 x ¾ in. angles with compensation in lieu of heel pieces. The floors are of steel plate 16 x 7 20 in. in the hold space, increased in thickness in engine and boiler space and flanged on top where required. The beams of 5½ x 3 x 10 20 in. angle on alternate frames are fitted with bracket knees of ample depth. The centre keelson is formed of channel bar. The main deck stringers are of plate 30 x 7 20 in. amidship, and are connected to shell plating by riveted angles 3 x 3 x 5 20 in.

The garboard strake is 9 20 in. thick, the sheer strake 11 20 in. thick, and the remainder of the hull plating ¾ in. thick amidship. Riveting of shell plating seams is double throughout. The bulwarks are of 5 16 in. thick steel

pump. The decks are of British Columbia fir as are also the cabin floors, etc. The equipment consists of steam and hand steering gear in the wheelhouse, and a "Dake" steam windless fitted under the turtle deck forward. The fore-mast is 13 in., and the mizzen mast 11 in. diameter. Each vessel has two Bower and one kedge anchor. A ship's boat of wood is carried fully equipped.

Machinery

The propelling machinery consists of a fore and aft compound surface condensing engine having cylinders 18 in. and 38 in. in diameter by 24 in. stroke. The high pressure cylinder is fitted with a piston valve and the low pressure with a double ported slide valve. The crank shaft 7½ in. diameter is built up, counterbalance weights being attached to the cast steel webs. The couplings are also of cast steel. A separate thrust shaft with solid forged collars is installed. The surface condenser is cast on the engine back column and contains 900 square feet of cooling surface. The air pump is of the Edwards type. The circulating pump, bed and bilge pumps are Blake-Knowles type, and are attached to the main engine and driven by levers attached to the low pressure cross-head. The propeller shaft

is fitted with bronze sleeves, while the stern-tube is of cast iron with a removable brass bush filled with lignum vitæ. The propeller is of cast steel with four blades. A feed water heater is provided.

than 12,000 B.t.u. per lb., and with .75 in. forced draught. There are two top and two bottom drums one set of two drums belonging to each element. Each element has 378 tubes of 2 ins. in diam-

tical duplex 8-5-12 in. pump is installed to draw from the sea and fresh water tank, and to discharge to deck service and boiler. The sanitary pump 5 $\frac{1}{2}$ -3 $\frac{3}{4}$ -5 in. is a horizontal duplex Blake-Knowles unit. Electric lighting for general and searchlight purposes is supplied by a 10 k.w. direct connected steam engine and generator. A complete evaporating outfit is installed having a capacity of 8 tons per day.



SHOWING THE "VIMY" TAKING THE PLUNGE.

The main steam piping is of seamless steel tubing with steel flanges, while all other pipes including the exhaust are wrought iron. The main boiler feed and blow off pipes are, however, made of copper.

Boiler Installation

The boiler is of the "Howden" combination sectional marine, two element, type. The total heating surface is 1870 sq. ft., the grate area 44 sq. ft., and the working pressure 180 lbs. per sq. inch. The evaporation available is 9,000 lbs. per hour from a combined heat absorbing surface of 1870 sq. ft., and 44 sq. ft. grate area using coal of not less

eter by 4 ft. 6 in. long between tube plates. Howden latest and improved type of forced draft equipment is fitted, an air heater being installed on the boiler front. Hot gases from the flues are utilized for this purpose. The drums of each element are connected by equalizing pipes while a steam drum connects the top elements for the main steam pipe connection. The boiler is tested by water pressure to 360 lbs. per sq. inch. The steel frame work supporting the boiler is designed and constructed to allow full freedom for any expansion that may take place.

A general service Blake-Knowles, ver-

MONTREAL INTERESTS ACQUIRE WOOD SHIPBUILDING PLANT

A GROUP of Montreal capitalists, including William Lyall, president of the P. Lyall & Sons' Construction Co.; H. W. Beauclerc, a Lyall director, and others of their associates, have acquired the wooden shipbuilding branch of the Wallace Shipbuilding Co.'s business at Vancouver, B.C., and will at once incorporate a new company to carry on the business. The company will have a Dominion charter. The negotiations were recently concluded at Vancouver by Mr. Lyall, who had been at the coast for some time going into the matter. The purchase price has already been paid over. This is a going concern, with a number of vessels now under construction.

Accompanying Mr. Lyall were two representatives of the Imperial Munitions Board, who have satisfied themselves as to the company's ability to build ships, and a contract for several vessels for the British Government has already been closed. These vessels will be of the standardized 3,000-ton type already being built on the coast. They will cost approximately \$400,000 each, and the company expects to be able to turn out a number this year. The property purchased from the Wallace Co. includes three shipbuilding slips, and three more will be constructed, so that several vessels may be building simultaneously.

The new company has an experienced staff of experts engaged for the more responsible positions.



SHOWING THE FOUR VESSELS ON THE WAYS PREVIOUS TO LAUNCHING.

PRODUCTION METHODS AND DEVICES

A Department for the Interchange and Distribution of Shop and Office Data and Ideas Evolved from Actual Practical Application and Experience

SPECIAL CIRCULAR TURNING TOOL

By J. H. R.

WHEN turning the nose profile of the various size shell, difficulty has often been experienced in maintaining a uniform contour on each; this being due more particularly to the variation in the shape of the cutting tool after each grinding or re-setting operation. Owing to the parallel advance of the cutting tool, it is obvious that the working point will gradually change as

its life, as the tool may be reversed without changing its shape or setting. The tool is used on the finish turn operation and can machine quite a number of shells before regrinding is necessary. When the edge becomes dull, the clamping screw is released and the circular tool turned about one-eighth of a revolution, thus giving 16 settings, using both sides, before regrinding is required. After the edges have been ground, however, the height of the cutting edge must be adjusted by raising the stud B to the de-

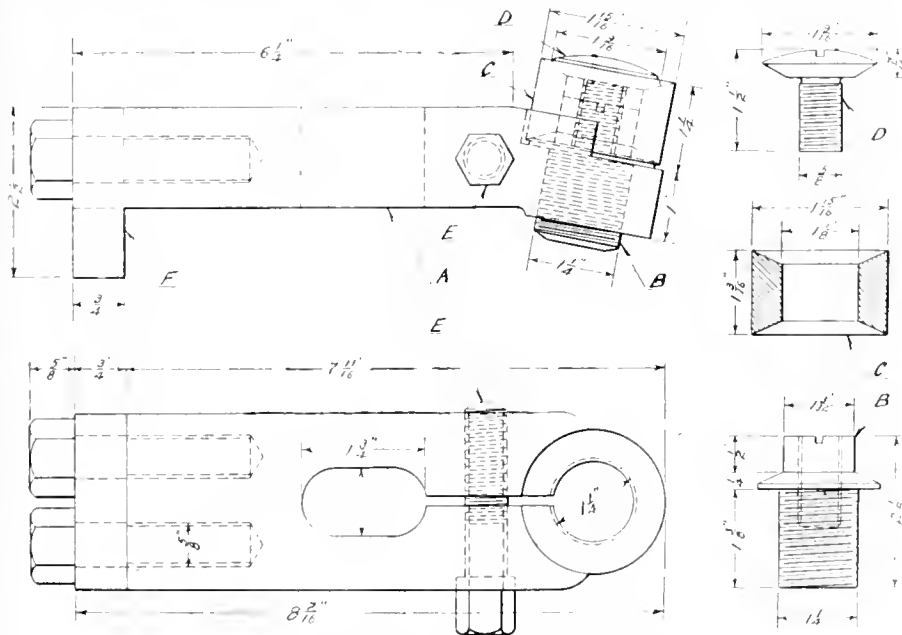

FIG. 1. SPECIAL CIRCULAR TURNING TOOL.

the tool approaches the small diameter at the nose, and for this reason it is essential that special attention be given to the shape and setting of the tool, so that a uniform profile will be turned on each shell. To eliminate as far as possible, the trouble caused by faulty grinding, the tool shown in the accompanying sketch, was designed by the Modern Tool Mfg. Co., and its efficiency has been demonstrated where it is found necessary to machine work by the cam or radius method.

The details of the tool and holder are shown in Fig. 1; the holder is made of 2 1/2 inch by 1 1/2 inch low carbon steel, the front portion being inclined at an angle and bored and threaded to receive the adjustable stud B. The upper end of this stud is turned to fit the central hole of the circular cutter C, and is drilled and tapped to receive the clamping screw D. The bevel portion on the stud B and also on the head of the bolt D, are the same so as to fit the bevels on either side of the cutter C; this facilitates the setting of the tool and increases

sired position and again clamping it firmly by means of the cross bolt E. The plate F, secured to the back end of the tool holder, provides means for adjusting the depth of cut and also preventing backing away from the work.

Fig. 2 shows a plan view of the tool in position on the tool rest, with clamping and side adjusting bolts, the latter being necessary to maintain the cutting tool in the same relative position on the shell as the roller occupies on the cam; or in the case of the radius arm, in the same radial line as the centre of the profiling link. From the sketch, Fig. 2, it is clear that the circular tool here illustrated will not have those objectionable features that are so pronounced in the ordinary type of turning tool. When the cam has been developed for a certain diameter of cutting tool, the variation of the cutting point between G and H will remain the same irrespective of how many times the circular tool is set, care being taken to have it always at the same height after regrinding.

PULLEY TURNING RIG

By J. E. McCormack

THE accompanying sketch shows the plan of a rig which I fixed up and used for turning pulleys. The size and proportion of the parts should be governed by the class of work to be done. I use this one for pulleys up to 28 in. dia., with bores of 1 1/2 to 3 in., and used 2x4 in. scantling for the pieces EE, and 1x4 in. for legs and braces, these parts being made of wood. The arbor used was 1 7/16 in. dia. and 3 1/2 feet long, and is driven by the cone pulley B.

The dotted lines at MM indicate the position of a pulley to be turned. L is a disc or face plate. D and H are supported by the side pieces and in turn support the chisel rests C, K, J. These are adjustable and removable in much the same manner as the long and short rests in wood turning lathes. D is movable to and from the arbor to accommodate differently sized pulleys.

The arbor is held from end motion by a collar just inside the frame and against the bearings. Two collars only. One could be put on each side of one bearing if preferred. The bearings are raised so that the center of the arbor is four inches above the upper surface of the pieces EE, thus allowing room for D C J K without raising them too high for convenience. A supply of bushings is kept for use in fitting pul-

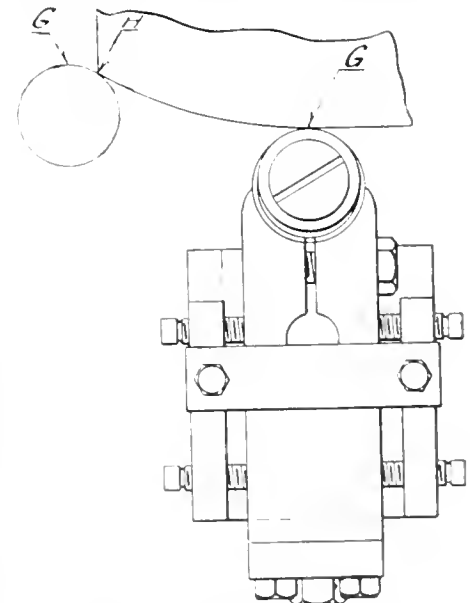

FIG. 2. SPECIAL CIRCULAR TURNING TOOL.

leys of different bores to the 1 7/16 in. arbor.

Very small pulleys are turned on the face plate, being held by a pair of wood screws passing through the disc. The

end of the arbor can be fitted with pin or screw as desired, but I did not do so, and, perhaps because of this, I found that in making small pulleys it was better for one not to bore them until after

driver. Of the three of these valves in the pump not one of them seated properly, because the leather had acquired a "set" in a shape that kept the flap sticking up, as shown in Fig. 2.

seat. After treating each valve in this manner, and priming the pump, it held water O.K., and worked satisfactorily right along although the less drastic remedies previously applied had proved unsuccessful.

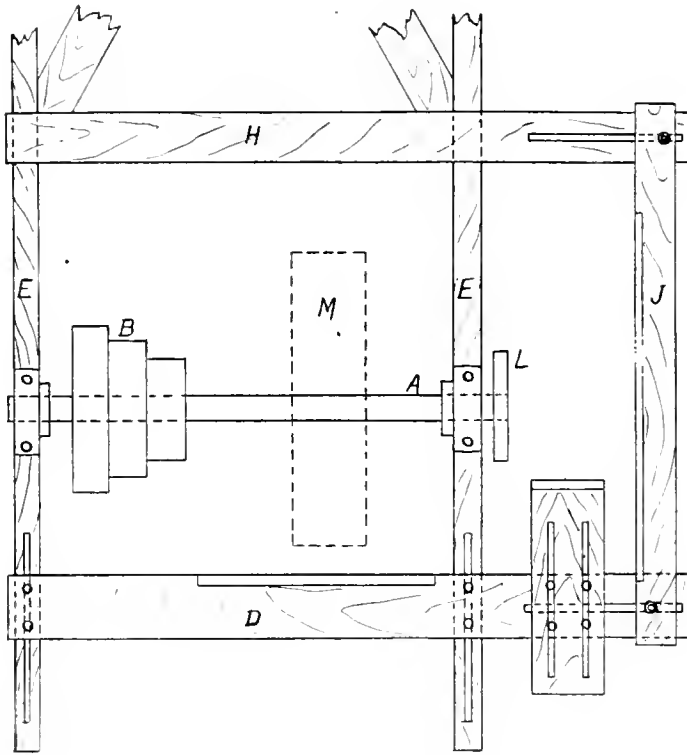

HOME-MADE PULLEY TURNING RIG.

they were turned. After finishing, I make a few circles on the side by using a pointed chisel on the rest J and these serve as a guide for centering exactly when setting up the work, and any slight shifting of the work previous to the lighter finishing cuts does not throw the finished pulley out of true when hung.

By removing the leathers from the pump, taking the screw out, and putting the plate and screw each on the opposite side of the leather from what they had been before, and then putting the

—⊗—
SPECIAL PATENTED ROLLER CHUCK
 By S. B.

AN outstanding feature in connection with the manufacture of munitions has been the great variety of chucking devices that have been designed and constructed for rapid production and economic operation. In general, the practice has been the utilization of the collet chuck, which is operated either by pneumatic power or hand appliances. Several manufacturers have however, adopted the self-acting type, where the gripping device is automatically operated, initially by the action of coil springs, and subsequently by the force of the cutting tool upon the work. The one shown in the accompanying sketches is of the latter type, and carries with it a somewhat interesting history. After constructing this special roller chuck, and demonstrating its remarkable efficiency, the designer, H. E. Bourassa, manager of the Modern Tool Mfg. Co. of Montreal, had the device patented, but not wishing to place any obstacles in the way of maximum production, the drawings were submitted to the Imperial Munitions Board, with the suggestion that any manufacturer desiring to equip their machines with these chucks would be privileged to do so, and could also secure additional drawings and further details for the construction of same. In appreciation of the patriotic spirit of the donor, the

—⊗—
FIXING A BALKY VALVE

By J. E. McCormack

SOME time ago I was asked to fix a balky hand force pump of the type in which valves are made as in Fig. 1, the same piece of leather serving both as gasket and as valve flap. On one side of the flap there was a brass plate covering most of the said flap and held in

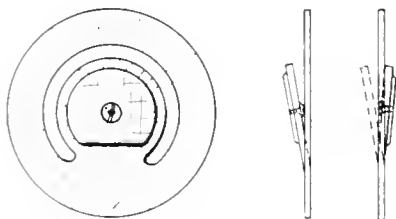

FIG. 1. OVERCOMING TROUBLE WITH HAND FORCE PUMP VALVE.

place by a screw passing through the leather and screwing into the plate. The head of this screw was broad, yet thin, and was slotted for a screw-

drivers back into the pump other side up from what they formerly were, I secured the aid of this "set" in the leather to help hold the valve to its

members of the board and other interested parties presented Mr. Bourassa with a beautiful diamond ring, a gift that has been more highly cherished than any

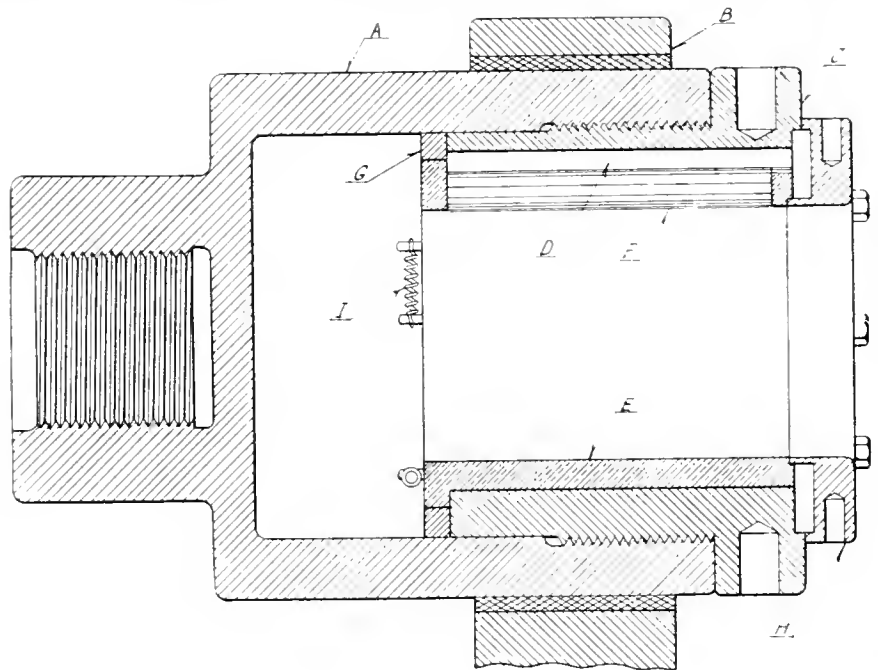

FIG. 1. ROLLER CHUCK FOR 6-INCH SHELL.

monetary consideration would have been.

The chuck here shown was developed from a previously employed collet chuck, the parts A and C being utilized for the new roller type. The piece C, formerly used for the operation of the old style, was slotted out to receive the three hardened tool steel cams D, placed equi-distant around the inner circumference.

SHELL HANDLING DEVICE

By R. Hamilton.

WHERE rollers are used for the revolving of shells while applying the varnish to the interior, it is necessary that the shell be raised a short distance in order to place it upon the rolls; and where a large number of shells are handed each

of the revolving shaft, as shown by the arrow, permits the shell to roll freely away when the centre board is moved upwards, raising the shell from the two rolls.

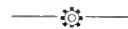

G.T.R. STRATFORD APPRENTICES' ANNUAL BANQUET

THE twelfth annual banquet of the G. T. R. Stratford shops apprentices took place on Saturday evening, June 16, in the spacious hall attached to the plant. Those occupying the head table were Master Mechanic C. Kelso, A. W. Smithers, of London, Eng., chairman of the Grand Trunk Railway Board; W. D. Robb, of Montreal, superintendent of motive power of the Grand Trunk; H. R. Safford, of Montreal, chief engineer; H. R. Semple, Toronto; D. McCuaig, master mechanic, Toronto; E. R. Battley, Portland, Me., formerly an apprentice in the local shops; G. Meldrum, Montreal, supervisor of apprentices; C. A. Mayberry, principal of the Collegiate Institute; Chas. Farquharson, president of the Board of Trade; Mayor J. D. Monteith, James Powell, H. E. Whittenburger and W. A. Booth, Toronto; R. H. Fish, superintendent, Stratford; and Robert Patterson, of Montmagny, Que., formerly master mechanic of the local shops. The large assembly hall was tastefully decorated with flags and red, white and blue electric light bulbs.

After the toast to the King had been duly honored, the chairman then called upon Ald. Chas. Farquharson, president of the Board of Trade, to propose the toast to "Our City," to which Mayor Monteith responded.

Grand Trunk Railway System Toast

C. A. Mayberry, in proposing the toast of the "Grand Trunk Railway System," simply requested the guests to arise and drink the toast, to which A. W. Smithers replied. Mr. Smithers deemed it a high honor and privilege to be present.

In referring to the war, Mr. Smithers, who came out from England about five weeks ago, assured those present that England appreciated everything Canada was doing. She realizes that it is harder to get men together over such a wide range of territory, whereas England is so compact.

The Apprenticeship System

The toast to the apprenticeship system was proposed by H. R. Safford, who said that he was convinced, after seeing the work of the boys, that the apprenticeship system in Stratford was a success and that the boys liked it. "I know by looking at the boys that they will make a success of life," said the speaker.

This toast was responded to by W. D. Robb, superintendent of motive power.

A toast was proposed to the visiting apprentices by Mr. Frame, of the local apprentices, and responded to by representatives of Montreal, Battle Creek and Ottawa shops.

After Robert Patterson, the late master mechanic, had expressed his pleasure at being present, the proceedings terminated with the singing of the National Anthem.

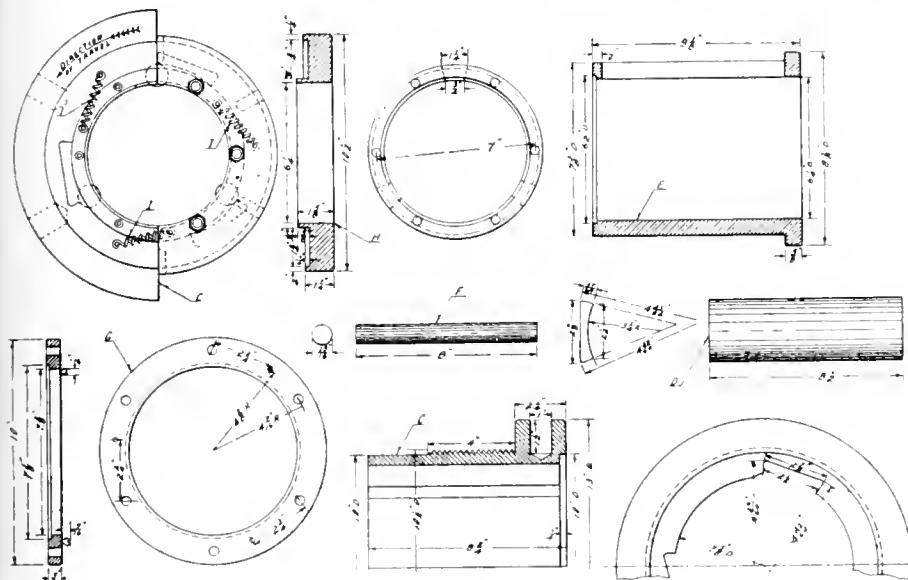
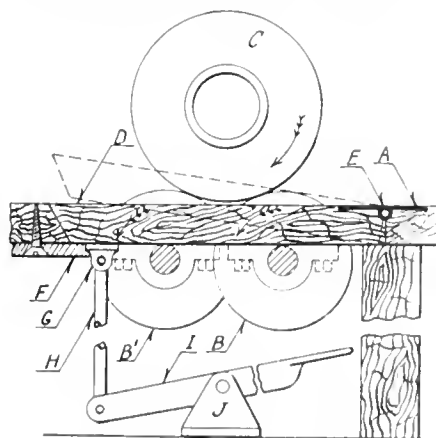

FIG. 2. ROLLER CHUCK FOR 6-INCH SHELL.

These cams are 8½ inches long and 2⅞ inches wide, the contact surface for the rollers having a width of 2½ inches. Fitted to the bore of the piece C is the brass sleeve E, having three equi-distant dovetailed slots 8 inches long to receive the hardened tool steel rollers F. The shape and position of the containing slots prevent the rollers from being dislodged when the shells are removed from the chuck, and also retain them in their relative positions of 120 degrees apart, thus insuring a uniform and concentric grip with the axis of the shell, irrespective of any slight variation of the outside diameter. Retaining rings G and H, one on either end, keep the mechanism in a permanent position, being prevented from lateral movement by their position in the piece C. The front or outside retaining ring H is made wide enough to provide for operating pin holes as shown, and the inner surface is recessed out to receive the springs I, these springs being used for placing the initial pressure upon the body of the shell.

When the parts are bolted together, the brass bush with the three rollers is free to remove through a small angle, the chord of which will not exceed 2½ inches, this being the length of the operating portion of the cam. The back retaining ring G is secured rigidly to the piece C, and one end of the springs is fastened to this fixed portion (in relation to the chuck body), while the other end is placed on studs in the ends of the brass bushing. This chuck has given the best of satisfaction, is easy to operate, and owing to the almost entire absence of friction in the parts, the wear is reduced to a minimum, consequently repairs are seldom necessary. When repairs are required, the chuck can be easily dismantled and repairs effected.

day, it entails considerable energy to place them on and off the rolls. To reduce the labor required for this operation, and at the same time facilitate the moving of the shells during the process of varnishing, one firm devised the fixture shown in the accompanying sketch. A section of the bench between the two pairs of rolls was first cut out, and the piece D fitted in, this piece being hinged at one end as shown at E, the opposite end being supported by a suitable bevel, and also the plate F, which is securely fastened to the solid portion of the bench. As the shells are rolled along the bench from left to right, the swinging piece D is pushed upwards by means of the foot treadle I and the vertical rod H, the upper end being secured to the bracket G,



SHELL HANDLING DEVICE.

and the foot treadle fulcrumed in the bracket J, this being bolted to the floor in a suitable position. The rollers are revolved by means of a small belt running on a pulley secured to the back end of one of the roller shafts. The motion

Canadian Manufacturers' Association Convention

The importance of this annual function shows an increasing tendency with each succeeding year, due, of course, in large measure, to the recognized necessity of furthering our resources and industrial development from within, so to speak, and to the end that same be done as effectively as possible, so that we both appropriate and maintain a foothold in the world markets, while at the same time strengthening our position in strictly speaking domestic markets. The convention just closed has been marked by a free and whole-hearted investigation of the many problems involved, which will not fail to react beneficially.

PRESIDENTIAL ADDRESS BY COL. THOS. CANTLEY

NOT the least interesting feature of the annual convention of the Canadian Manufacturers' Association held in Winnipeg last week was the address by the retiring president, Col. Thomas Cantley, president of the Nova Scotia Steel & Coal Co.

Referring at the outset to the industrial advancement in Western Canada, Col. Cantley said that from a manufacturing standpoint, the development of the Western Provinces has fully kept pace with their development in other directions. With characteristic enterprise, their citizens have freely utilized the resources at hand to make themselves as independent as possible of outside sources of supply. In milling, in their preparation of animal products and in similar forms of production, there is no reason why the West should not greatly excel. In the heavier lines of manufacture her growth has been retarded by the high price of coal and power, but this difficulty, I am informed, is already partially overcome by the development of hydro-electrical energy, with a good prospect that further, if indeed not complete relief may shortly be had through the utilization of the vast deposits of lignite with which the West abounds.

Problems of the Day

The various problems upon which the Canadian Manufacturers' Association has been engaged during the past year are fully discussed in the reports submitted. As these reports are presented, it will become increasingly apparent that the direction of our activities was frequently beyond our control, in the sense that it was forced by unusual conditions brought about by the war. We have been passing through times of uncertainty and stress, and we must be prepared to face greater uncertainty, and still greater strain before the Empire and our Allies have won liberty's great victory.

Labor has never been in so great demand in Canada as it is at present, and never so highly paid. Manufacturing materials of every kind have greatly advanced in value,

and are still daily becoming increasingly difficult to secure. In some instances the prohibition of their export from other countries has made it necessary for us to have recourse to inferior substitutes. For a considerable portion of our normal products there has ceased to be a demand, so that many manufacturers have had to adapt equipment to the manufacture of new products, and cultivate new markets. The movement of traffic has been attended by exasperating delays. Owing to the shortage of production and the difficulties of transportation, coal has advanced to famine prices, threatening to deprive us of both heat and power. Our expenses have been increased by the necessity of providing liberal compensation for industrial accidents. Our Legislatures, meanwhile, have added to the list of statutes that tend to interfere with—when they should facilitate—inter-provincial trade, and over and above all these troubles we have begun to feel the burden of taxation which before long must fall with even greater heaviness upon us as the war in-

debtedness of Canada becomes greater.

Association Aims

Be it remembered that the real function of the Association is to give service, to advance and protect the interests of Canadian manufacturers, to foster the growth of Canadian manufacturing industries, and to assist in the development of Canadian export trade. So long as we keep within these general limitations, we are engaging in legitimate work, and within our sphere of influence—when we exceed these bounds, we are liable to both encounter and make trouble.

So far as criticism of the Federal Administration is concerned, wisdom suggests that every such organization as ours should move slowly and circumspectly in times like the present. We never have had and never in our time will have a perfect Government. Perchance the present day may be no better than its predecessors—but it has larger problems, greater responsibilities and more difficult duties confronting it than any previous Canadian Government has been called on to face. Destructive criticism is useless. Can we show a better way? If so, express it. Do the Government courageously meet an awkward difficulty? Applaud. Are they vigilant and energetic and fair? Give them credit at least.

Manufacturers Unfairly Criticised

Perhaps this point has been unduly dwelt upon because of my unwillingness to believe that some of the criticism that has been leveled against the Government may have been quite as unfair and quite as unjustified as much of the criticism that has been leveled against the manufacturers. Man for man, the manufacturers are probably as good citizens as any other class in the community. They courageously kept the wheels of industry in motion at a time when the country was becoming panic-stricken over the prospects of unemployment. They have conscientiously applied themselves to the task of providing the materials needed for the carrying on of the war. They have worked inde-



COL. THOMAS CANTLEY.

fatigably to surmount difficulties by which many an armchair critic would have been overwhelmed. They have responded generously to every call for subscriptions to the Patriotic, Red Cross, Naval and other war funds, and have done their duty by various Canadian war loans, yet it has become the fashion from one end of Canada to the other to revile them as profiteers, trafficking in the blood of their country, mainly because a comparatively small number of them have shown large profits.

It is not accounted unpatriotic of the farmer if he is now receiving good prices for all his products. The artisan is not held up to condemnation because he now receives four to six dollars per day in payment for work he gladly did for two and a half or three dollars before the war. The pay of the British soldier is one shilling per day, and maintenance, but the Canadian soldier is not thought to be bleeding his country because he draws \$1.10 per day for similar services. Yet the manufacturer is scourged with abuse if he makes a profit on business which he accepts at a price in many cases below that paid for similar work and service to American and British manufacturers.

Taxation of Profits

The cumulative effect of this tirade of abuse is now being felt by our successful manufacturers in various ways. Notwithstanding the fact that wages are on an unprecedentedly high scale, it is being alleged that they are grinding the faces of the poor, and the demand is being made that they should pay still higher wages. Our Legislatures are scaling up the compensation allowances, and in case of permanent partial disability are saddling industry with annuities that may easily represent more than 100 per cent. of wages when the latter are reduced to a reasonable basis, as in time they must be.

In some quarters it is being suggested that the supposed enormous profits made from manufacturing would justify the Government in removing the protection of the tariff. In other quarters it is being seriously advocated that the entire expense incurred through Canada's participation in the war be met by the taxation of business profits. Last year the Federal Government saw fit to provide itself with an emergency revenue by levying a tax on business profits, and although the amount secured largely exceeded their expectations, they have recently announced that that tax is now to be very substantially increased, presumably to some extent in deference to this uninformed public opinion.

It is greatly to the credit of manufacturers as a class that in the face of so much provocation they have avoided any display of resentment. They have paid and will continue to pay their war taxation with cheerfulness, trusting to a reasonable administration to secure them fair treatment. They have done their duty by the dependants of employees who have gone to the front, and will likewise do their duty by the soldiers who return. They will come to the as-

sistance of the farmer this year, by releasing men to help him with the harvest, and they will pay high wages just as long as the condition of their business makes it possible to do so.

After the War

A time will come, gentlemen—and it may come sooner than some of us think—when the manufacturer will be unable to carry the load he is carrying to-day. Had he been asked five years ago whether he could continue to do business at a cost for labor and material such as he is paying to-day, he would have laughed the question to scorn. Yet he is in business and making a profit, but only because there are governments that still must have supplies and are prepared to pay the price. That demand will collapse with the termination of the war, and prices will immediately fall. Twenty millions, perhaps more, of the forty million men who have been withdrawn from producing and other occupations, will return to their homes and to such employment as may be offering. National borrowings of staggering proportions will have to be repaid, and the only way they can be repaid will be by the countries' increased production. A world that for three years has to some extent neglected commercial production will suddenly apply itself thereto with greater zeal than ever, with the result that we will witness an era of competition such as has never been known before. Under these circumstances all prices must tend steadily downward, and wages must do the same. The profits accruing from manufacturing will narrow in proportion until we reach a point where capital will temporarily cease to be attracted to industrial enterprise.

To all of us who have given the situation any serious thought, two facts must stand forth conspicuously. From the standpoint of production there will be gradually but surely cut off from us an export trade in war materials amounting now to perhaps \$800,000,000 a year. Manufacturers cannot immediately adapt themselves to new lines of production, nor can they immediately find new markets. With the coming of peace, there will necessarily be a period of pause, of readjustment, with delay of development until the general business situation becomes clarified sufficiently to justify the employment of capital in new ways. There will be a widespread release of men now engaged in the manufacture of munitions and military supplies, probably numbering 100,000 to 150,000. These large numbers will be steadily added to by the soldiers returning from the front, for most of whom employment will have to be found.

A Sound Fiscal Policy Desirable

It may well be borne in mind that no solution will give satisfactory and permanent results that is not based on the principle of supplying as far as possible our own wants and producing in addition thereto something exchangeable at a profit for such commodities as we do not grow or cannot produce. Such a policy will lift us out of debt and set our feet on the highway of prosperity.

In the troublous times still ahead of us this country will need all the help she can secure from men of enterprise, from men of business capacity, who, when opportunities present themselves, can quickly secure and employ the requisite capital to bring profitable industry into operation. Canada can best obtain that form of help by shaping her fiscal policy so as to create opportunities for home and foreign business, for, given opportunities, capital and enterprise will do the rest.

The wisdom of a sound fiscal policy could find no better proof than in the magnificent service rendered by our manufacturers since the outbreak of the war. During thirty-five years of moderate protection, Canada was able to build up for herself a large and varied industrial equipment of first-class efficiency. The speedy adaptation of that equipment, supplemented by very large investment in new plant, probably exceeding \$25,000,000, for the production of munitions and war supplies, not only enabled Canada to render assistance of immeasurable value to the Allied cause, but it also enabled her to keep her workmen fully employed at high wages at a time when, but for her possession of that equipment, and but for the enterprise of her manufacturers, Canadian artisans would have had to seek employment beyond her borders.

Our national policy of tariff protection never needed any justification for the results always spoke for themselves, and if it did, then surely the wonderful achievements of the past two and a half years have furnished that justification in abundant measure, and discredited the free trade propagandists who have consistently sought to belittle the importance of our manufacturing industries. These industries have done yeoman service in the cause of freedom, not the least important features of which have been the contributions they have enabled Canada to make to the army in fighting men, and to the treasury in money.

Again, these industries of ours will continue to give a good account of themselves under a policy of moderate protection, for, notwithstanding new conditions, opportunities will arise of which discerning manufacturers will be quick to take advantage.

Shipbuilding

The address next referred to the possibilities of developing a great steel shipbuilding industry, reviewed the history of the business in Canada, the natural opportunities afforded, on the Great Lakes, the St. Lawrence, and the seaboard, spoke of the experience of the United States, showed how large the amount of capital required would be, and what industrial advantages would follow, and concluded:

"A bounty that would provide sufficient encouragement would quickly stimulate the growth of shipbuilding, supply the incentive for the establishment of plate mills, and would lead to the specialization of our engineering trades. This would be followed by a two-fold advantage—first, in that it would shorten the time and cheapen the cost of con-

structing vessels and so make it possible for the industry ultimately to get along without a bounty, and second, in that it would open up a wide field for the profitable employment of our returning soldiers, and particularly of thousands of munitions workers, whose present outlook is clouded with uncertainty. Above and beyond all these reasons, however, the building up of a Canadian mercantile marine will insure that the agricultural products of this wide Dominion, as well as its export of manufactured goods, will be carried not only over Canadian railways, and internal waterways, but their transport beyond the seas will be in Canadian bottoms, and the profits resulting therefrom would accrue to the advantage of the Dominion and add to our wealth instead of enriching foreign shipowners, as at present.

Technical Education

On the subject of technical education, the address said: "Canadian workmen as a class are possessed of great adaptability and a high order of natural intelligence, and quickly become expert machine operators, but the Canadian artisan outside of the engineering class usually labors under the disadvantage of not having served an apprenticeship, and of having no opportunity to become familiar with the mathematics and the scientific principles upon which his work is based. In a young country like Canada, whose industries are in the making, there is a constant demand for men who know how things should be done, who understand why they should be done in a particular way, in the only way, and who can instruct others, and who, when things go wrong, can put them right—in brief, trained men who can be entrusted with responsibility. Neither our present factory system nor our educational system makes provisions for the training of such men. In consequence of which our industries and our workmen both fail to make the progress they should, or reap the rewards which their industry entitle them to."

In conclusion, Col. Cantley said: "To those members of the Association present or absent, whose sons have passed over to that great company of immortals, who think of lonely graves somewhere in France, I respectfully tender my admiration of the nobility of your silent suffering, and my sympathy in your sacrifice."

"Remembering what our brothers and sons have done and are doing, the valor and the sacrifice of Britain, the gallantry and endurance of France, the agony and crucifixion of Belgium, and the dreadful sufferings and losses of Serbia and the other Allies — recalling these things, it is our duty as Canadian manufacturers, as citizens living in this country—in prosperity, in comfort, no enemy yet on our coast daring to make us afraid—recalling these it seems to me that we should work as never before—for production is essential. We must pay as never before. We should do it honestly, we should do it cheerfully. We should support and encourage the Government of the country, whatever be its political

complexion, so long and so far as the members of the Government are actively and energetically engaged in prosecuting the war. Let us remember that they are human, not infallible, and generally quite as patriotic as ourselves. If we are to help as we should, and can, we must be open-handed, in some sense sentimental, and abundantly sympathetic.

"We meet under the shadow of a great war—a war beyond all historic precedent—a war for the preservation of human liberty, in which not only the Motherland, the sister Dominions, and our own country, but other Allied nations, are vitally engaged. In the titanic and deadly struggle in which your sons and mine, and those of many of our fellow-citizens throughout the Dominion, have been for many weary months engaged, thousands have daily gone down to the Gates of Death, and many have already passed its portals, having won glorious immortality, sacrificing their young lives for their country and world liberty..

"It seems to me that it befits us now for a moment to turn our thoughts to them, to recall their courage, their endurance, their valor, their gallantry — those who have given all, those yet alive, but who are daily risking their all—let us thank them, let us honor them—these gallant knights who have done so much to advance the glory, the honor of Canada, and the stability of constitutional government and freedom not only in this Dominion, not only in the Empire, but in Europe and the world."

SYNOPSIS OF PROCEEDINGS

THE forty-sixth annual general meeting of the Canadian Manufacturers' Association opened in Winnipeg on Tuesday, June 12. The various sessions were held in the Convention Hall of the Fort Garry Hotel and were attended by a large number of manufacturers from all parts of the country. On Tuesday evening a reception and smoker was tendered the visiting delegates by the Winnipeg members of the Association, brief addresses of welcome being delivered by Mayor R. D. Waugh, of Winnipeg, Hon. T. C. Norris, Premier of Manitoba, and W. R. Ingram, Chairman of the Prairie Provinces Branch of the Association. Fitting replies were made by Col. Thomas Cantley, president of the Association, S. R. Parsons, of Toronto, first vice-president, and W. J. Buman, second vice-president.

At the first business session on Tuesday morning, reports of the secretary and treasurer were read, and the presidential address delivered by Col. Cantley. The afternoon session was occupied by the reports of the executive and insurance committees. On Wednesday morning the legislation and tariff committees submitted their reports, and in the afternoon the transportation committee report was read. On Thursday morning amendments to by-laws were taken up, followed by the election of officers and committees. The feature of the meeting was the presidential address by Col. Thomas Cantley, a synopsis of which will

be found in another section of this issue. Summaries of reports of the various committees are as follows:

S. R. Parsons presented the report of the Executive Committee in which it was pointed out that the Association's revenue for 1917, \$66,623.30, was the largest it ever enjoyed. By the Trade Index a profit of \$2,242.40 was yielded, and the earnings from Industrial Canada showed an increase of \$613.33, the sum of \$376.54 being received in the way of interest on investments. However, there was a deficit on the year's operations of \$5,535.15, whereas there was a surplus last year of \$4,922.59. To offset present conditions the committee is calling for a general increase in the schedule of membership fees.

High Insurance Rate

The efforts of the Insurance Committee, according to the report presented by W. H. Shapley, chairman, have been mainly directed during the year towards protecting the manufacture in his right of free access to the market for unlicensed insurance.

Following a comprehensive resume of the insurance activities of the year, the committee reported, in reference to the tax on unlicensed insurance, as follows: "The situation meanwhile is that such a tax is operative in Western Canada, but not in Eastern Canada. Our efforts this year have been exercised in trying to protect our eastern members against something which our western members are already suffering from. To be consistent, we ought to work with equal zeal for the elimination of the tax in the West, for there can be no question but what it is responsible for unnecessarily high rates of insurance in this territory, to say nothing of the fact that the existence of such a law in any Province is always more or less of an invitation to other Provinces to follow suit."

In the report of the Legislation Committee as presented by Geo. C. Copley, chairman, mention was made of the fact that the past year has offered abundant opportunities for work. An outline was given in detail of the legislation passed affecting the association. Included in the list are the Extra-Provincial Corporation Licensing Acts, the Alberta Corporations Taxations Act, the Commission of Inland Trade and the Business Profits War Tax Act. The taxation of the profits of munition manufacturers was dealt with fully, and due attention is paid, too, to Workmen's Compensation, the Alberta Factories Act, the Minimum Wage Bill and the Bulk Sales Act.

Railway Equipment

The necessity for additional railway equipment was brought strongly before the association in the report of the Transportation Committee. Attention was called to the recommendation of A. H. Smith, president of the New York Central Railroad, in the minority report of the Railway Commission, that the Government should undertake at once to provide for an ample supply of freight cars and locomotives against immediate and

imperative needs. The committee urged that the convention should make some representations to that effect to the Government.

The valuable work done by the committee in connection with freight rates and other railway matters of prime importance to manufacturers was set out at length in the report. Commenting on the findings of the Royal Commission appointed to inquire in railways and transportation in Canada, the committee emphasized the necessary duplication of railway lines and facilities throughout the country and contended that legislation was absolutely necessary to guard against such evils in the future and to protect investment already made.

The Association closed its convention on Thursday with a discussion of between four and five hours' duration on the Canadian railway situation, and eventually passed a resolution calling upon the Government to take immediate steps toward overcoming the desperate need for equipment by providing an ample supply of cars and locomotives and turning them over to the companies under lease or contract of purchase. The motion also embodied a resolution that a board of trustees be appointed to receive all monies of these companies unable to meet their obligations, and to determine and supervise expenditures of railway companies to whom advances have to be made.

The discussion revealed a desire on the part of a number of the members for nationalization of the railways, and an amendment was introduced asking that the Government put administration of all the railways of Canada under one body with a view to co-ordinating the entire service. This amendment had a great body of support at one time, but on the representation that what was immediately wanted was an increase in railway equipment, and that the greater scheme could be deferred, the motion of the resolution of the committee was carried.

A number of other motions were carried at the forenoon session, among them being one giving hearty endorsement of the Government's proposals for conscription. The patronage system was denounced as being a controlling factor in both Federal and Provincial Governments in determining who should enjoy Government business, and a strong resolution calling for the abolition of this principle was passed unanimously.

Another resolution was passed calling for the establishment by the Government of laboratories for the solution of industrial problems, and another authorizing a delegation to approach the Provincial Government with the view of taking steps to prevent fires, which, it is estimated, caused losses annually of approximately \$20,000,000.

New Officers

S. R. Parsons, of Toronto, was elected president for the ensuing year; W. J. Bulman, Winnipeg, and T. R. Howard, Montreal, vice-presidents, and J. F. Ellis, Toronto, treasurer, in succession to Mr. Booth, who retired after over 20 years' service in that capacity, and who, it was

agreed, will be given some tangible indication from the association of its appreciation of his long and gratuitous service.

The election of members to the Executive Council and various committees was as follows:—

Executive Council, Appointive

Executive Council, appointive:—W. K. McNaught, Toronto; C. B. Gordon, Montreal; P. W. Ellis, Toronto; C. A. Birge, Hamilton; W. K. George, Toronto; C. C. Ballantyne, Montreal; H. Cockshutt, Brantford; R. Hobson, Hamilton; R. S. Gourlay, Toronto.

Executive Council, Elective

Maritime Provinces—Geo. Henderson, Montreal; C. A. Lusby, Amherst; Bruce Stewart, Charlottetown; S. E. Elkin, St. John, N.B.; Angus McLean, Bathurst village.

Montreal—G. F. Benson, Montreal; J. R. Colby, Montreal; W. A. Desbarats, Montreal; S. W. Ewing, St. John's; D. J. Fraser, St. John's; Chas. E. Frosset, Carl Riordan, S. J. B. Rollard, G. W. Sadler, Geo. A. Salter, F. W. Stewart, Ferd. Van Bruysell, Montreal.

Quebec City—Jos. Picard, J. H. Gignac, Quebec, Que.

Quebec Province—C. R. Whitehead, Three Rivers; F. J. Campbell, Windsor Mills; J. E. Alain, Victoriaville.

Sherbrooke—E. W. Gilman, Montreal.

Toronto—Geo. Bridgen, G. Frank Beer, W. C. Coulter, R. D. Fairbairn, Thos. Findley, E. J. Freyseng, S. Harris, R. L. McIntyre, J. S. McKinnon, T. F. Money-penny, J. P. Murray, W. C. Phillips, Thos. Roden, W. B. Tindall, J. Westren, Toronto.

Hamilton—H. H. Champ, H. J. Waddie, H. H. Biggert, A. F. Hatch, Geo. C. Copley, Hamilton.

Ontario — Henry Bertram, Dundas; Don. M. Campbell, Preston; Geo. H. Douglas, Hamilton; Geo. E. Forbes, Hespeler; W. G. Gartshore, London; R. O. McCulloch, Galt; R. S. McLaughlin, Oshawa; W. R. Breyfogle, Peterboro; T. E. Matthews, Peterboro; John Runsford, Clinton; Alex. Saunders, Goderich; T. J. Storey, Brockville; J. M. Taylor, Guelph; H. I. Thomas, Ottawa; H. W. Fleury, Aurora; C. H. Waterous, Brantford; C. C. L. Wilson, Ingersoll.

Prairie Provinces—W. S. Fallis, W. A. Matheson, T. R. Deacon, W. R. Ingram, M. F. Christie, F. W. Drewry, Jas. Caruthers, H. R. Eide, Winnipeg.

British Columbia — Alex. MacLaren, Barnett; A. C. Flumerfelt, Vancouver.

Members of Other Committees

Tariff Committee—E. J. Davis (Chairman), Newmarket; Geo. H. Douglas, Hamilton; Geo. W. Watts, Toronto; H. H. Champ, Hamilton; C. F. Wheaton, W. C. Phillips, C. V. Harding, L. L. McMurray, Toronto; S. J. Williams, Kitchener; Geo. Henderson, Montreal; C. H. Carlisle, Toronto; W. M. Gartshore, London.

Transportation Committee—J. A. Riordan (Chairman), Toronto; J. E. Ferguson, Woodstock; W. R. Dunn, A. F. Hatch, Hamilton; C. E. McGhie, St. Ca-

tharines; W. R. Ingram, Winnipeg; A. W. White, London; W. R. Breyfogle, Peterboro; D. A. Campbell, West Toronto; C. L. Wisner, R. P. D. Graham, E. C. S. H. Champman, F. C. Gibson, Toronto; A. H. Brittain, Ross McMaster, Montreal; M. F. Christie, Winnipeg; Henry Bertram, Dundas; A. D. Huff, B. W. Coghlin, Montreal; L. L. Anthes, Toronto.

Legislation Committee—Lloyd Harris (Chairman), Toronto; Geo. C. Copley, Hamilton; S. Harris, Toronto; H. J. Waddie, Hamilton; G. Y. Chown, Kingston; Atwell Fleming, C. B. Lowndes, J. O. Thorn, Arthur Hewitt, F. M. Kimbark, Toronto; A. W. White, London; Aemilius Jarvis, Kingston; Howard Smith, M. Hirsch, Montreal; Wm. Georgeson, Calgary; T. A. Potter, Saskatoon; Geo. D. McKinnon, Sherbrooke; H. I. Thomas, Ottawa.

Insurance Committee—W. H. Shapley (Chairman), Toronto; C. C. L. Wilson, Ingersoll; J. W. Millard, Hamilton; Thos. Roden, Toronto; A. H. Ivey, Toronto; H. W. Fleury, Aurora; Kerr, Hamilton; J. F. M. Stewart, Toronto; A. C. Ransom, Toronto; J. P. Murray, Toronto; F. J. Sleight, West Toronto; G. F. Benson, Montreal; Chas. E. Frost, Montreal; Jno. Bain, Woodstock.

Membership Committee—W. C. Laidlaw (Chairman), Toronto; J. Allan Ross, Toronto; K. Bethune, Hamilton; J. A. Seythes, Toronto; H. J. Hall, Toronto; L. L. Anthes, Toronto; W. C. Coulter, Toronto; E. G. Staunton, Toronto; Geo. Simpson, Hamilton; S. H. Chapman, Toronto; H. P. Hubbard, Hamilton; J. A. McMahon, Hamilton; A. C. Neate, Toronto; T. Boyd, Winnipeg; H. R. Eide, Winnipeg; W. H. Marsh, Hamilton; Geo. A. Sluter, Montreal.

Exhibition Representatives

Representatives to Canadian National Exhibition—R. S. McLaughlin, Oshawa; H. J. Waddie, Hamilton; J. R. Shaw, Woodstock.

To Central Canada Exhibition Association—Geo. H. Miller, Ottawa; Col. J. W. Wood, Ottawa.

To Western Fair Association—Arthur W. White, London; W. N. Manning, London.

To Edmonton Exhibition Association—Geo. C. Robson, Edmonton.

Auditors—Wilton C. Eddis & Sons, Toronto.



Customer—"Send up twenty-five cents' worth of boiled ham."

Butcher—"All right, sir. Anything else?"

Customer—"Yes. If my wife isn't at home, tell the boy to put it through the keyhole!"—Life.

"Now, boys," said the teacher, "there were two rich men; one of them had made his fortune by honesty and industry, while the other had made his by fraud and roguery. Which of these two men would you prefer to be?"

There was a moment's hesitation, then young Solomon Isaac's hand went up as he quietly enquired, "Which made the most?"

CONTEMPORARY WAR ARTICLES

Embracing Information and Data Drawn from a Variety of Sources Relative to and Arising from the Prosecution of this Many-Sided European War

METRIC SYSTEM, ITS MEANING FOR THE MACHINE SHOP

WHEN the metric system was introduced, manufacture was in its infancy, and the methods of the present had not even come to birth. Only a few people followed "handicrafts." Unification would have been an easy matter then. Later, when Whitworth attempted it in screw threads alone he was confronted with a herculean labor. To-day, the attempt to impose a new system of measurement for the vast total of engineering products in the tens of thousands of shops in England and America would result in financial disaster, and handicap their efforts for a generation to come. Theorists dream of an easy transition, a smooth changing-over from one system to the other, a substitution of dimensions in a price list or catalogue, an obliteration and a beginning anew. The best answer to such a view is to show broadly how much is involved in the present methods of manufacture.

Effect on Drawings

To those who imagine that a change over to the metric system would involve no more than is entailed in the preparation of drawings and designs to the new dimensions, and manufacturing from those drawings, the following facts may be suggested. It may be granted that in so far as the drawings themselves alone are concerned the expense might be negligible, if only all firms were beginning business with a clean slate, but they inherit a legacy and an incubus from the past. During many years of work many thousands of costly drawings representing standard products have accumulated. Made from these are thousands of tools, appliances, patterns, forging-dies, and some specialized machines, all based on the British units of measurement. The drawings are now made with immensely more elaboration than of old, and their numbers are multiplied exceedingly. Formerly only the principal dimensions were inserted, small radii and unimportant sizes being neglected. Again, large-scaled and full-sized drawings were avoided as much as possible, and before the days of cheap prints one dirty and tattered drawing would frequently go the round of several machines. Now the detail dimensions are greatly multiplied. Nothing is too minute to be figured up, drawings of detailed parts are made and printed lavishly, those to full size, or to half or quarter scales, being preferred when size limits permit, but the labor of re-dimensioning is correspondingly increased. To reconstruct, re-dimension, and replace the major portion of these would entail an increase in staff and an expense that only the wealthiest firms could contemplate. It would hinder the undertaking of new orders, and cause

confusion worse confounded than any handicap which might possibly arise from the retention of the present system. Yet this would be but the beginning of the trouble. In the machine shop it would become a real catastrophe.

Gear Cutters

The single-edged cutting tools used in lathes, planing and shaping machines and slotters would offer no difficulty, since their dimensions and outlines are not related to any basis of measurement, but nearly all tools outside these groups are so related, and would be affected by the change. As regards form gear cutters, a set of eight is provided for each separate involute diametrical pitch, the eight ranging from 12 to 14 teeth to a rack, and these must be multiplied by the smallest number of pitches which may be stocked, say, perhaps, 20, ranging from 1 to 20 d.p. When for the sake of quiet running very strict approximation to accuracy is required, these sets must be supplemented by other cutters, made exactly to the tooth shapes required. Also, where rapid production is studied, the work of the standard cutters which finish is preceded by those of another series which stock-out or gash the tooth spaces with stepped teeth that breaking up the chips, cut faster than the others.

When there is a demand for gears of circular pitch, an entirely distinct set of cutters is necessary, 24 in number, since the sectional shapes are those of double curves. For bevel gears other sets of cutters are required, thinner than those used for the spurs, to permit the cutters to pass between the small ends of the teeth. Again, as the gear cutting machines are built in different dimensions and capacities, the arbors of the heavier machines are of larger diameters than those of the smaller ones. Consequently the holes in a set of cutters made for one machine will not fit the arbors of machines of other capacities. Further, while large stocks of cutters of carbon steel have been accumulated, there are in addition ever growing stocks of those of high speed steel.

In the generating methods employed for spur gears and worm wheels, and for some worms, large numbers of hobs are used. For spurs there must be as many hobs as there are pitches, and these tools are very costly. The worm wheels vary not only in reference to pitch, but very much more so in the worm diameters, in lead, and in numbers of threads, from single to quadruple; and for every variation in each kind a distinct hob is required, so that the stock of a firm doing a large business may number some hundreds of expensive hobs. Hobs are also made tapered to be fed longitudinally. Another group of cutters is re-

quired for double helical gears of spur and bevel types, operating endwise or normally to the surface on which the teeth are produced.

The milling cutters and many of the gear mills are only a variety of the gear-cutting class—that is, they operate in precisely the same fashion, and they are form tools, although their functions are not the same. The stocks of these cutters are not inferior in numbers to the gear cutters. In many shops they would comprise a larger group, but only a moderate proportion are dimensioning tools, and these chiefly occur in the gang mills. The grooves and dove-tailed grooves in machine tools are milled with solid cutters, the dimensions of which are fixed. The cutters for sprocket wheels also are of fixed dimensions, and so are key-way cutters and those for slitting screw-heads. Where cutters are put on arbors, the bores would be affected by a change in dimensions, and those with solid shanks have standard tapers and diameters.

Drills and Reamers

In their close approximation to accuracy of dimensions, drills, reamers, and boring tools rank as high as any other tools. As in the gear cutters, the question of changing them over to metric measures can only be answered in the negative. They must be exactly to size.

Consider for a moment how enormous is the stock of drills and allied tools which a machine shop has to carry, ranging, say, from $\frac{1}{4}$ in. up to 6 in., advancing by sixteenths, and frequently by thirty-seconds in the smaller sizes. Many are required in more than one type. Of twist drills, which predominate, some must have straight parallel shanks, others shanks tapered to Morse or other standards. Some have flutes of constant angle, others with increasing twist. Many are of high-speed steel. Another large group of drills lies outside these forms. Instead of the regulation two flutes, some have three or four grooves. For brass work, straight-way drills are used rather than the twist form. There are many twist drills in use made as were the original ones by twisting a flat bar of steel. A large number of the old flat-flipped drills are still employed, in preference to the twist forms. D-bits are a large group. Tap drills are a large class, each being made for one size of hole to be tapped, and these are multiplied in sets for Whitworth, gas, and other standard threads. Finally, the lengths of drills of the same diameters vary from normal lengths, being shorter or longer for special duties.

For a large proportion of the drills, the requirements of high-class and interchangeable work can be met only when there is a corresponding reamer to finish the hole to precise size. These tools also

have parallel and tapered shanks. Many have parallel flutes, others spiral ones, with plain and rose ends. Again there is a large group of chucking reamers used in chucking machines, turret lathes, and automatics, having straight and spiral flutes. There are also floating and expanding reamers, both tapered and of shank and shell types.

Screwing Tackle

Taps, dies, and allied tools, whether used by hand or operated in machines, present another tremendous problem which manufacturers would have to solve in the event of a change in measurement. If it only involved the sets of hand-taps and dies, as in the old days, the task would be a colossal one. Yet that is a very small affair by comparison with the field now occupied by machine-cut screw threads, which embraces the solid dies and taps which are used in turret lathes and screw machines, and in the screwing machines for bolts, nuts, pipes, etc.; tools that are gripped in holders, the rotation of which is reversed after the thread has been cut; together with the opening dies and the collapsing taps which are used in ever-growing numbers in the same classes of machines, in which the holders do not reverse, but where the chasers are caused to fly open in the dies and collapse in the taps, when the end of the thread is reached. There are several designs of these, and a large range in sizes, and in systems of threads. The thread-milling cutters are another growing group.

Measuring Instruments

Appliances such as instruments of measurement and jigs and fixtures present as formidable a barrier as the tools do to the change contemplated. Instruments of measurement include all the forms of divided callipers, fitted with the vernier or with the micrometer screw, each one suited only for the system for which it is graduated. The principle of division and the graduations are applied also to measuring tools other than the callipers, as in depth and rod gauges and in the costly standard measuring machines for shop testing of tools.

There are also the fixed gauges, which total to an appalling aggregate in present-day practice. Their numbers are always increasing, and none of them would be of any value as they stand, without correction or renewal, for any system of measurement but the one they are made for. The reference or standard tool room gauges come under the same category, as, too, do all indicating tools that have graduations, and all the rules and the scales used in offices and shops.

In any machine shop of average size where interchangeable manufacture is carried through, the jigs and fixtures aggregate many thousands. A change over in measurement would condemn a large proportion of them to scrap, and if the main portion might be saved, many fittings would have to go. All bushings for drills and reamers would be incorrect, as would also be many of the minute adjustments by which tooled parts are set, and the readjustments which would have to be effected would often entail nearly

as great expenses as the making of a new jig or a new fixture.

Machine Tools

To assume that the machine tools—the plant of a shop—would not be touched by a change in measurement would indicate superficial knowledge. Main framings, shafts, spindles, broad out-lines, and arrangements, and many details would not be affected. But much more than these goes to the making of many machine tools. The lead screws of lathes would have to be changed, as would their clasp nuts, and the chasers or master screws of turret chasing lathes, and of the vast numbers of Fox lathes used by brass finishers, with their die nuts. There are also the feed screws and their nuts, and micrometer dials which now indicate advances in thousandths of an inch. Many machine tools have steel rules on faces and edges to facilitate settings of work. Costly boxes of gears provide ranges of feeds. Collet jaws grip definite sizes of rolled bars. Spindles of lathes, of boring, drilling, and milling machines, are bored and ground to receive the Morse or other standard tapers, based on the inch. Enormous numbers of turret lathe tools, many being very expensive, used on turret, cross-slide, and chasing saddle, are standardized on the basis of the inch. These would have to be re-made or discarded before a change could be completed. Grinding wheels would be a source of trouble, since their holes would not fit metric spindles and arbors. The large stock of arbors or mandrels used for grinding wheels, milling and gear-cutting machines would be incorrect, and all the solid mandrels that are stocked for chucking through bores.

Gears

Another complicated problem is presented by gears, since they are used on machine tools and on an infinity of motors and machines, in which the past, as well as the present, is involved. The old cutters must needs be retained, else worn and broken wheels could not be replaced. The cutting of gears in the present and future to module proportions would cause trouble because diameters and shaft centres would be affected—unless, indeed, approximations should be tolerated, in which case the ideal would be sacrificed. All wheels would come under the influence of these drastic changes—spur, helical, spiral, bevel, worm, and the circular and involute pitch systems.

Re-dimensioning

It has been suggested with more ingenuity than knowledge that the contemplated change might be made by retaining the present tools, gauges, drawings, etc., and re-dimensioning them in terms of the millimetre. Surely those who think thus cannot be qualified to offer an opinion on the subject that would commend itself to shop managers. Tens of thousands of tools and appliances would have to be re-measured and re-stamped in a machine shop of only average size; many hundreds of thousands of new dimensions would have to be inserted on drawings. Often it would be

cheaper to scrap tools and drawings than to take such a task in hand.

Supposing, however, this herculean labor to have been accomplished, the new system would still be but a bastard one, because the inch and metric measures are not interchangeable. A metre measures 39.37 in., and the inch equals 25.4 mm., and they are not translatable, apart from the use of tantalizing decimals. If this irreconcilable bastard system should be followed, or a true metric measurement adopted, two standards would have to be maintained for a generation or more. This would entail, in addition to the appalling expense of renewals, the doubling of storage spaces and of book-keeping, an increase in the staff and in the number of hands, and an enlargement of machine tool areas.—*Times Engineering Supplement.*



DOMINION STEEL CORPORATION ANNUAL MEETING

"WE are booked up in steel products to the end of the calendar year," President Workman told the shareholders of the Dominion Steel Corporation at the annual meeting last week, "and in addition to that our shell steel output for the first six months of 1918 has been disposed of." This was supplemented later on by the president's statement that unfilled orders at the present time were double those of a year ago and further that the business was not subject to cancellation.

Mr. Workman reviewed in some detail the improvement in the financial position of the corporation effected in the past year by the retirement of notes, etc., and the elimination from the balance sheet of the item of \$2,000,000 "discounts and premiums on securities" which involved a recurring annual charge of about \$225,000. For the current fiscal year he estimated that the annual interest charges would be about \$500,000 less than two years ago—this in addition to interest on bank loans which have been eliminated.

Plant Improvement

As to physical improvements at the plants the remodeling of the blast furnace department was making progress and two batteries of new by-product coke ovens were being installed which would result in lower coke costs, while permitting of the utilization of the company's total blast furnace capacity which is now greater than can be taken care of owing to the limited coke production. Difficulties in the coal department due to scarcity of labor and ships were dealt with in some detail, but the president indicated that the outlook for the current year was fairly satisfactory. In a general review of the present position and the after-the-war outlook, Mr. Workman had this to say:—

"While the statements now before us indicate a greatly improved condition as compared with the previous history of the corporation, it must not be forgotten that lean years have been the rule rather than the exception, and it must therefore, be my policy to exercise con-

servation in all our undertakings. I feel particularly committed to this course, having in view the keen competition that will undoubtedly arise after the war.

"Many corporations engaged in the steel industry across the border, have been able, partly through exemption until a comparatively recent date from taxation, and partly by reason of other advantages resulting from the attitude of neutrality long maintained by their Government, to accumulate large surpluses, and to practically amortize their plants. We, in Canada, have borne responsibilities of this nature for a much greater period, and it must not be lost sight of, that however gladly and willingly we have shouldered the burdens which have fallen upon us as our share in the prosecution of the war, none the less does this condition demand careful study and the exercise of rigid economy, in order that we may not be placed in a position of disadvantage as regards our competitors.

When Peace Comes

"Our chief problem, therefore, lies in the meeting of the conditions which may arise after peace terms have been signed, and I consider it good business to fortify ourselves in every possible way, so that when the time comes, we will be in such a position that the problem of meeting competition will not be insurmountable. Following out this policy, as I have stated already, our annual interest charges have been greatly reduced, and I might say that these charges for the current fiscal year will be more than half a million dollars under the figures of two years ago—this in addition to interest on bank loans, which have been eliminated.

"Many expressions of opinion have been presented at one time and another with regard to conditions which may prevail after the war, and while it is given to no man to definitely foretell the course of events, I feel, as far as the demand for materials such as we manufacture is concerned, that we may look to the future with confidence. It is inevitable that replacements and renewals, and replenishments of stocks throughout this country and abroad, which have been given second place during the urgent call for war materials, must, when conditions again become normal, culminate in a strong demand for products of all kinds. We should, however, be prepared for adjustments immediately following the declaration of peace, which may possibly result in a period of lessened industrial activity more or less extended. Nevertheless, the underlying need will seek to assert itself at the first favorable opportunity, and will sooner or later force merchants and consumers into the market.

"These problems, as I have said before, belong to the future. As for the present, I am happy to report that we are booked up in steel products to the end of the calendar year, in addition to which our shell steel output for the first six months of 1918 has been disposed of."

After the presenting of the president's address, H. Gordon Strathy asked if it were not possible for the shareholders to

have more than one statement a year. To this the president replied that he could promise a statement of the output of steel each month, but that it was rather difficult, owing to the fact that a varying amount of business was done during the different seasons of the year, to issue satisfactory quarterly or half yearly reports of earnings.

Asked if it would not be possible to pay a quarterly dividend on the subsidiaries' preferred stocks, instead of half yearly, the president replied that the right to do that would have to come from the shareholders. That and the question of earning statements would not be lost sight of, and he personally would give them serious consideration.

Most of the Montreal directors were present and among the out of town directors were Hector McGinnis, K.C., M.P., Halifax; Brig.-Gen. Sir Henry Pellatt, Toronto; Lt.-Col. the Hon. F. Nicholls, Toronto; W. D. Matthews, Toronto, and Brig.-Gen. the Hon. James Mason. Other shareholders present were: M. E. Williams, F. W. McAnulty, A. Michaud, S. L. Herman, Geo. H. Bishop, W. R. Miller, C. W. Lindsey, P. E. Brown, Thos. Tate, F. J. Lewis, A. P. Frizon, R. B. Verner, A. LaRose, J. B. Clearihue, J. J. M. Pangman, L. McIsaac Sprackman, Dr. E. E. Simard, G. D. C. Dobbin, Dr. E. M. Hill, J. Gow, J. N. Cote.

CANADIAN GOVERNMENT RAILWAYS STATEMENT

A SURPLUS of earnings over operating expenses amounting to \$1,137,713 on the Intercolonial Railway System and a deficit of \$1,966,626 on the National Transcontinental Railway during the past fiscal year, were reported by Hon. Frank Cochrane in his annual statement to the House of Commons on June 12, with reference to the operations of the Government railways. That system now comprises 4,063 miles of railway made up of the Intercolonial, 1,562 miles; Transcontinental, 2,009 miles; Prince Edward Island Railway, 275 miles; International Railway, 112; St. John Valley, 105.

The earnings of the Intercolonial, Mr. Cochrane said, were abnormally low during the four winter months because the road was engaged in hauling war materials and had to embargo many lines of freight which paid higher rates. Moreover, on that line, the operating expenses were augmented by increased materials and supplies and increased cost of coal, materials and supplies and increased wages and also by the unfavorable weather conditions and the congestion of traffic at Montreal.

Earnings amounted during the year to \$16,802,290, and operating expenses to \$15,664,577, leaving a surplus of \$1,137,713, as compared with \$1,517,295 in 1915-16. The surplus, the Minister of Railways said, would be absorbed by the equipment renewal account.

On the Transcontinental, earnings amounted to \$5,916,550, as compared with \$3,758,387 in 1915-16, and operating expenses were \$7,883,177, as compared with \$4,410,528. The deficit, Mr. Cochrane stated, was due to the comparative-

ly small amount of traffic offering for that railway, to the fact that trains not warranted by business had to be established and to the necessity for maintaining the road at the standard of other transcontinental lines.

Operating Expenses

The operating expenses of the entire Government Railways System for the fiscal year ended March 31 last, were \$24,645,433, as compared with \$17,797,061 in 1915-16; the earnings were \$23,465,565, as against \$18,373,143. The deficit for the whole system in 1916-1917 was, therefore, \$1,179,867. The total number of passengers carried on the system was 5,673,796, including 277,155 men of the military and naval forces, who traveled in 443 special trains.

The total estimated cost of the work on the Prince Edward Island car ferry terminals and railways leading thereto, is \$2,910,000, of which \$2,600,000 has been expended.

Rails have been laid on the Hudson Bay Railway to Mile 232, which is the second crossing of the Nelson River. Of the 92 miles remaining between the bridge and Port Nelson, all is graded but 11 miles. The bridge across the Nelson will be completed this summer and the rails will be laid into Nelson this year. Work has been slowed up on the Nelson harbor owing to war conditions. The estimated cost of railway and harbor work is \$26,000,000, of which \$18,175,000 has been expended—\$12,565,000 on the railway and \$5,610,000 on harbor terminal work.

The estimated expenditure on the Welland Ship Canal is \$50,000,000, and of this about \$13,000,000 has been spent. Work has been suspended on the canal owing to war conditions, but it is in such condition that no damage is anticipated during the period of suspended operation.

The Trent Valley Canal is practically completed between Lake Simcoe and Lake Ontario. The section to connect the Severn River with Georgian Bay has not yet been placed under contract.

Train Braking on Quebec Bridge.—The long suspended span of the Quebec bridge, 640 feet between pins, will be subject to a sudden movement, over the 17 in. leeway provided, when brakes are applied to a high speed train passing over it. In order to restrain this influence a traction brake is provided at the end of the cantilever arms. This brake is made up of a series of plates that slide between each other and are kept in contact by a set of car springs under a constant compression. Every alternate plate is fixed by a pin at one end to the horizontal piece of chord at the end of the cantilever arm and has a slotted hole at the other end to allow the necessary motion on the pin, which fixes the remaining sliding plates to the suspended span. These remaining plates are slotted in a similar manner, so as to allow the same amount of motion on the pin connecting the first-mentioned plates to the cantilever arm.

Metal Planers, and Methods of Production Employed*

By Charles Meier**

High-speed steel and the desire to obtain the highest possible speeds in both directions have rendered changes in planer design imperative. One of the objections to speeding up has been the difficulty encountered at the reverse. This was at first partly overcome by lightening the driving pulleys, and has now been satisfactorily met by the reversible motor drive. To eliminate fatigue of the operator and save time, rapid power traverse is now generally used. This is quite a departure from the standard construction in which the heads are hand operated. Comparatively little thought has been given to handling planer work.

THE problem of providing the increased speeds and power to develop the possibilities of high-speed steel and to meet the increasing necessity for greater production has been a comparatively simple one in such machines as lathes, drilling machines, boring mills, milling machines in which the cutting is continuous and the motion of the tool is in one direction only. In this type

drives were designed in which the pulleys were not reversed. Our experience with these drives was that they developed the objectionable features inherent to friction clutches, namely, the slippage and wear which takes place before the parts are properly engaged. The most successful of these types was the pneumatic clutch. A few planers were built which embodied heavy springs to overcome the shock at reversing. We designed one machine in which these springs were added into the driving gears, and in another machine the table rack was made floating and held in place by two heavy springs at either end. These designs did not prove satisfactory, owing to the variable pressures while under heavy or light cutting. Also the springs had very little effect at the moment of reverse.

This constant change of conditions and

drives were designed in which the pulleys were not reversed. Our experience with these drives was that they developed the objectionable features inherent to friction clutches, namely, the slippage and wear which takes place before the parts are properly engaged. The most successful of these types was the pneumatic clutch. A few planers were built which embodied heavy springs to overcome the shock at reversing. We designed one machine in which these springs were added into the driving gears, and in another machine the table rack was made floating and held in place by two heavy springs at either end. These designs did not prove satisfactory, owing to the variable pressures while under heavy or light cutting. Also the springs had very little effect at the moment of reverse.

Length of stroke, ft.	Time table was running, min.	Number of cutting strokes with c.i. pulleys, weight 56 lb.	Number of cutting strokes with aluminum pulleys weight 20 lb.	Number of strokes gained	Theoretical number of strokes	Per cent efficiency of aluminum pulleys
2	30	306	350	44	415	84.3
4	30	165	189	24	207	91.3
10	30	76	82	6	83	98.7

TABLE 1—TEST ON 30 x 30 x 14 FT. "CINCINNATI" PLANER TO SHOW GAIN IN STROKES, AND EFFICIENCY OF ALUMINUM DRIVING PULLEYS OVER CAST IRON DRIVING PULLEYS. CUTTING SPEED 40 FT. RETURN SPEED 90 FT.

of machine it has meant merely adding power and strengthening parts.

The speeding-up process introduces, however, a vastly different problem in such machines as slotters, shapers and planers, in which the cutting is not continuous and which have a return motion of the tool. The principal limitations of machines of this class, especially the planer, are twofold, first, the inertia of the moving mass at the moment or reverse; second, the speed at which the tool enters the work. The problem of overcoming these limitations has had the attention of quite a number of engineers, and while considerable progress has been made the complete solution does not seem to have been reached.

Evolution of Planing Machine

The evolution of the planing machine has followed along the lines of increased table speeds. The earlier demands were all for a higher return speed, in the belief that great savings could be effected by reducing the idle time consumed in the return of the table. It next followed that further gains could be made by increasing the cutting speed, owing to the fact that this part of the cycle consumed the greater part of the time involved. The advent of high-speed steel can be cre-

ated largely with the marked advance in this part of the development. After fairly high speeds in both directions were obtained there came the demand for variable cutting speeds. It soon became a recognized fact that to operate a planer having only one cutting speed was both wasteful and detrimental to the best methods of increased production.

Aluminum Alloy Driving Pulleys

It seemed that none of these arrangements quite met all conditions, and to overcome the difficulties in the standard belt-shifting machines experiments were conducted with lighter driving pulleys. A step which marked quite an advance in this direction was the use of an aluminum alloy for the pulleys instead of cast iron, so that a decided gain was made in the number of cutting strokes owing to the fact that less time was consumed in the reverse. Table 1 gives results of a test made on a 30 x 30 x 14-ft. planer

Amp. gear box and loose pulley	Amp. planer in direction of cut		Amp. planer in direction of return		Amp. reverse from cut to return		Amp. reverse from return to cut		Length of stroke, ft.	Remarks
	with c.i. pulley	with aluminum pulley	with c.i. pulley	with aluminum pulley	with c.i. pulley	with aluminum pulley	with c.i. pulley	with aluminum pulley		
15	20	20	27½	28½	132½	106½	91½	75	0.66	Lengthening the stroke from 8 in. to 20 ft. does not alter the result 2 superseded other way
14	22½	20	30	28½	132½	105	93½	76½	20	
16	21½	21½	30	30	130	105	95	76½	20	
15	21½	20.4	30	29½	132½	105	93½	76½	This line is average	
4.4	6.3	6	8.8	8.6	39	30.9	27½	22.4	Average hp.	

TABLE 2—TEST OF 76 x 62 x 32 FT. "CINCINNATI" PLANER WITH CAST IRON AND ALUMINUM PULLEYS

er part of the trouble was caused by heavy machine pulleys and their high speeds. Various types of magnetic, pneumatic and mechanically operated clutch

and gives good idea of the gains effected by the use of aluminum pulleys. These pulleys were also found to effect quite a saving in power. Table 2 shows a test

*From paper read at A.S.M.E. Spring Meeting, May, 1917.

**Of Cincinnati Planer Co.

made on a 76 x 62 x 32-ft. planer, in which the saving in power was about 25 per cent.

Individual Electric Motor Drive

The subject of individual electric motor drive for planers has received considerable attention in the past few years. One type of drive which has been suc-

cessful and easy control of the machine is receiving quite a lot of attention in almost every machine operation, and there is no doubt but that great possibilities in this direction exist in machine-tool construction. Power operation of heavy machine parts seems to have found a permanent place in the construction of all

throughout the day, and is a decided help to the operator as it saves him from undue exertion and fatigue.

Production

As a general rule comparatively little thought is given to the subject of handling work on the planer. If the same amount of time and study were devoted to providing jigs and fixtures for the planer that is given other machining operations, the saving in time would be astounding. In the majority of cases a careful analysis will show that the machine itself is engaged during only a small portion of the total time taken to complete the operation. The balance of this time is lost in setting the work, measuring for roughing cuts, fitting for finishing cuts, and changing and grinding tools.

In planers, as in any other machines, we depend on the operator to a large extent for the best results. Invariably the question of chucking work on a planer is left to his discretion, and he proceeds to the best of his ability with the equipment allotted him, which usually consists of an assortment of bolts, clamps and blocks instead of jigs and fixtures.

I have found innumerable cases in which the chucking time alone almost trebled the cutting or machining time. Adding to this the time lost in changing tools and measuring work, we find as an average that the total actual time required to complete a piece of work is

	Single belt drive	Double belt drive	Pneumatic clutch running at 200 r.p.m. on cut and 600 r.p.m. on return	Pneumatic clutch running at 70 r.p.m. on cut and 200 r.p.m. on return	Direct-connected electric motor having cutting-speed range of more than 2 to 1 and a total speed range of 4 to 1
Drive, hp....	25	25	25	25	25
Stroke, ft....	8	8	8	8	8
Approximate cutting load, hp	25	25	24	26	31
Peak load reverse to return, hp.	55.5	44.3	75	25	20
Peak load reverse to cut, hp.	25	55	36	15	20
Time return stroke, sec.	7.2	7.2	7.6	6.8	5.6
Time cut stroke, sec.	20	20	19.5	16	13.4
Time of cycle, sec....	27.2	27.2	27.1	22.3	19
Ft. per minute return stroke	66.6	66.6	63.2	70.5	35.7
Ft. per minute cut stroke	24	24	24.6	30	35.8
Ratio cut to return, one to ...	2.78	2.78	2.57	2.35	2.4

TABLE 3—TEST MADE BY GENERAL ELECTRIC CO. ON 60 IN. x 72 IN. PLANER.

cessful developed in the variable-speed drive. This consists of a 2 to 1 variable-speed motor coupled direct to the top driving shaft of the planer. The speed of this motor is controlled by two separate sets of resistance which are automatically operated by a master switch connected to the shifting mechanism of the planer. The cutting speed can be varied from 25 to 60 ft. per min., while the return speed may be varied if desired without affecting the cut. The controller handles are set to a predetermined speed before starting. The planer is operated in the usual manner from the tumbler, and the master switch automatically varies the speed of the motor at each reversal. This type of drive has the desirable feature of eliminating the mechanically operated speed variators and is quite simple in operation. It provides a very flexible arrangement when variable speeds are desired. This is especially true on the smaller sizes of planers.

Reversible Motor Drive

The motor is an adjustable-speed unit, having a speed range of 1 to 4, so that a large range of cutting speeds from 25 to 60 ft. per min. can be obtained. A double set of resistance is provided making it possible to vary either cutting or return speed independently of the other. This arrangement has also simplified the problem of variable speeds in connection with this drive. The operating mechanism is handled in exactly the same manner as is the standard belt-shifting-type planer, so that no complications are encountered by the operator. Two predominant features in this type of drive are the total absence of belt slippage under heavy cutting and the lower peak loads at the moment of reverse. Table 3 shows the importance of these two features over the belt drive. It can be said that the reversible motor drive as applied to-day furnishes all that can be desired of an efficient planer drive.

The study of fatigue of the operator

classes of machinery. There is an increasing demand for elimination of lost time between cuts, and this feature has also found its way into the design of planers.

Rapid power traverse is now being generally used in manipulating planer

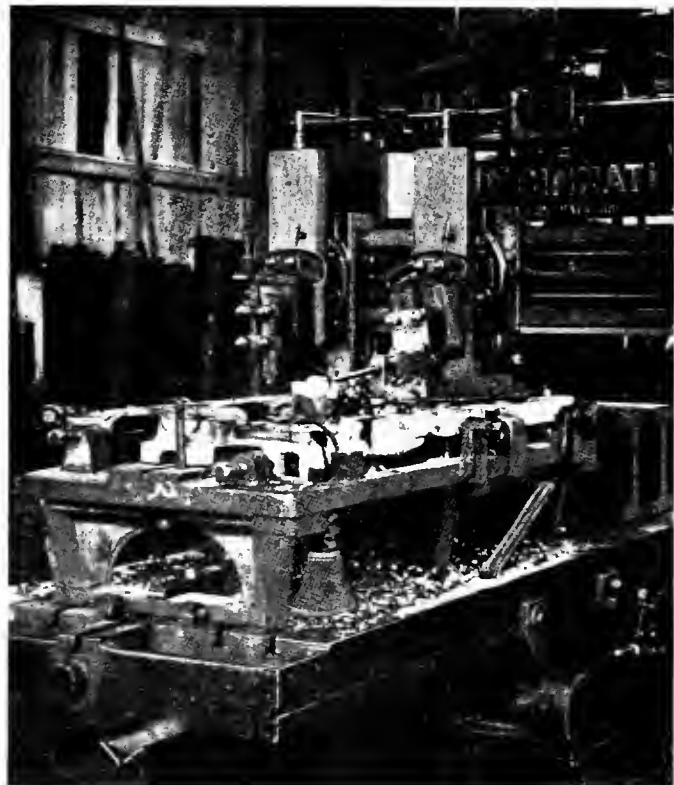

FIG. 1. EXAMPLE OF TIME-SAVING JIG ON PLANER.

heads in all directions. This is quite a departure from the standard construction in which the heads are operated entirely by hand. Experience has demonstrated that the new practice eliminates a considerable amount of wasted time

from 4 to 5 times the theoretical time necessary to plane the piece, the theoretical time being based on the number of square inches to be placed and the cutting and return speed used.

It is not surprising to find that where

time studies are conducted frequently a saving from 50 to 200 per cent. in time is effected, this through the elimination of wasted chucking and measuring time.

In the greater number of cases a holding fixture with screw adjustments can be devised so that it is only a matter of dropping the piece into this fixture and applying the clamps, which should be part of the fixture. Hardened steel plugs can also be incorporated into the jig to indicate the various heights and angles of the piece without the use of scales or referring to a drawing. These are a great help, especially in the roughing operation. Gang tools and double-end cutters also assist greatly as they save considerable time in getting correct sizes without measuring.

As an example of what this jiggling up has meant in one instance, Fig. 1 shows a shortwall coal-cutting-machine main frame being planed. For quite a while these frames were planed in the old-fashioned way by clamping and stopping them on the planer table. The average time required for planing with this method was 28 hours. Since the proper jigs and fixtures have been provided, these frames are now being planed complete in 4 hours. On this jig bosses are planed on which hardened blocks are set for setting the tools.

Another very good result obtained by time studies is the planing of locomotive cylinders complete in one setting. As a general rule these cylinders are planed one at a time and several settings are required. After a careful study, fixtures were provided which were so arranged that four surfaces could be planed at one time, using four tools for the cutting instead of only one. The saving in time on a pair of these cylinders was about 100 per cent.

The building of high-grade planers has established itself as an important factor in the machine-tool building field. Many users seldom realize that, unlike smaller machine tools, the building of a planer requires a more extensive equipment of machinery, as well as a large number of costly fixtures and measuring instruments. The planer is necessarily a large and expensive machine, and proportionately larger returns are obtainable from it than from smaller machines owing to the higher expense or burden charged against it. The planer, therefore, should receive special attention from the time-study department.



IRON AND STEEL IN CANADA, 1917
THE Mines Branch of the Department of Mines has received from the producers complete returns of the production of pig iron in Canada, and with the exception of three small plants, complete return of the production of steel ingots and castings during the first three months of 1917.

The total production of pig iron during the three months was, 276,777 short tons, or an average monthly production of 92,259 tons, as against an average monthly production throughout 1916 of 97,438 tons.

Furnaces were in blast at Sydney, and

North Sydney, Nova Scotia; Hamilton, Port Colborne, and Sault Ste. Marie, Ontario, and a small electric furnace was operated at Orillia, producing pig iron from scrap steel. The blast furnace at Deseronto was idle throughout the period.

The total production of steel ingots

and castings during the three months was 403,880 short tons, or an average monthly production of 134,627 tons, as against an average monthly production of 106,268 tons during 1916.

The monthly production, exports and imports, 1916 and 1917, are shown in the accompanying tables:—

Pig Iron in Canada

	Production		Exports		Imports	
	Tons	Tons	Tons	Tons	Tons	Tons
January	1916	1917	1916	1917	1916	1917
February	562,097	89,187	1,635	106	4,456	5,473
March	or	83,801	1,393	732	4,101	3,502
April	monthly	103,789	2,725	1,394	5,602	7,442
May	average		80		5,963	
June	of		30		6,489	
July	93,683		221		3,196	
August	92,012		394		3,773	
September	87,864		3,902		3,961	
October	102,744		1,534		5,001	
November	113,608		4,344		5,933	
December	104,436		4,055		3,310	
	106,496		2,991		6,351	
Total	1,169,257		23,304		58,130	
Monthly average	97,438		1,942		4,919	

Steel in Canada

	Production of Steel ingots and direct steel castings		Imports*	
	Tons	Tons	Tons	Tons
January	589,553	130,944	4,212	13,322
February	or	120,568	7,288	15,213
March	monthly	152,368	5,206	32,590
April	average		10,877	
May	of		8,542	
June	98,259		11,368	
July	100,817		10,742	
August	107,273		13,412	
September	113,411		10,433	
October	123,469		12,958	
November	124,431		12,723	
December	116,265		10,309	
	1,275,219		118,070	
Monthly average	106,268		9,839	

*The figures given hereunder represent the exports of steel ingots and billets from the United States to Canada and are compiled from the monthly reports of "Foreign Commerce and Navigation of the United States," Washington, D.C.

Iron and Steel in Canada, 1916

	1915	1918
	Short Tons	Short Tons
Iron Ore Shipments:		
Hematite	205,989	45,541
Magnetite	59,217	19,113
Roasted siderite and hematite	132,906	210,522
Total shipments	398,112	275,176
Sold for export	89,730	140,608
Imports (Customs record)	1,504,113	2,339,677
Charged to blast furnaces, Canadian ore	293,305	221,733
Charged to blast furnaces, imported ore	1,463,488	1,964,598
Charged to steel furnaces	74,872	55,059
Shipment from Wabana, Nfld.	868,451	1,012,060
Pig Iron Production by Provinces:		
Nova Scotia	420,275	470,055
Ontario	493,500	699,202
Production by grades:		
Basic	739,613	953,627
Bessemer	29,052	31,388
Foundry and malleable	145,110	184,242
Total production	913,775	1,169,257
Exports of pig iron	17,307	23,304
Exports of ferro-alloys	9,238	22,802
Imports of pig iron	47,182	58,130
Imports of ferro-alloys	13,758	14,777
Steel:		
Production of ingots and castings	1,020,896	1,428,249
Production of ingots by classes:		
Open hearth	962,411	1,377,387
Bessemer	19,448	1,446
Other steels	7,970	961
Electric steel		17,939
Direct castings by classes:		
Open hearth	28,384	23,496
Other castings	2,683	5,350
Electric		1,700
Electric steel, total production	5,625	5,350
Imports of steel ingots, billets and blooms from United States	58,486	118,070
Production of steel rails	232,411	90,123
Production of wire rods	124,381	179,226
Imports of tin plate	45,165	57,543
Value of total exports of iron and steel goods	\$48,248,148	\$63,837,681
Value of total imports of iron and steel goods	74,308,983	129,090,108

ELECTRICAL DRIVE FOR ROLLING MILLS

By O. C.

THE driving of rolling mills is one of the most difficult problems the electrical engineer has been called upon to solve. He has accomplished it quite successfully in a number of cases. The problem was an exceedingly difficult one even for the steam engineer; and the difficulty arises from the very quickly changing character of the load. Before the billet is entered between the rolls the only work the steam engine or the motor has to perform is the very trifling amount required to turn the rolls, along with the engine or the motor itself; immediately the rolls take hold of the billet the power rises to a maximum, which may be several hundred or several thousand horse power, according to the size of the rolls and the character of the work they have to perform. Immediately the billet emerges from the rolls on the other side, the whole of the power previously absorbed is set free, the engine or the motor now being required to furnish only the trifling power absorbed by the friction of the apparatus itself. The period of rest, however, as is well known, is very short, only sufficient to allow of the billet being re-entered between the rolls for the return pass; and immediately it is again entered and the rolls have gripped it, the power rises to a maximum, though usually not quite so high as the first pass; and this alternate no-load and full-load goes on until the billet has made all its passes; the power required being less at each pass, but being required each time for a longer period.

The first difficulty that confronted engineers in solving the problem was the question of meeting the requirements of the generating station. It is a very serious matter for any generating station to have sudden demands for very large currents, and still more for the station to be subject to the violent fluctuations of these demands. Most generating stations impose a limit upon power customers of the amount of current they may call for at any instant; and the reason is the outflow of a very large current from the generating station at any instant, lowers the pressure of the supply service for the time until the devices provided for meeting increased demand have time to operate. With the increased demand for current for power purposes, central station engineers have been gradually able to keep the lighting service free of the power service, and so they are able to allow larger calls on the power service than previously. But even where the power service is independent of the lighting service, the demand resulting from the insertion of a billet in the rolls of a large mill, would seriously lower the pressure of the service to all the other motors.

With modern methods of electric power distribution also over large areas by the aid of three phase alternating cur-

rents, heavy demands for current lead to somewhat serious induction troubles. The difficulty has been met in the same manner as with the colliery winding engine; in fact, the apparatus employed for driving rolling mills is a development of the electric winding engine. The fly-wheel again performs the useful office of absorbing the power that would be running to waste in the intervals between the different passes, and giving it out to aid the current taken from the service during the heavy starting and acceleration period. The interposition of the fly-wheel protects the electric supply service from the heavy demand that would otherwise be made upon it during the early portion of each pass. The full power released by the emergence of the billet from the rolls is not available to assist during the starting period, and therefore the economy to the user will not be so great as if he were allowed to take all the current he required directly from the service. On the other hand, if a central station did allow such an arrangement, it would be obliged to make higher charge for the current, and the cable employed to deliver the current to the rolling mills would require to be very large, or there would be a considerable lowering of the pressure at the motor, in addition to which, the drive would not run as sweetly as it does under existing arrangements.

PROBABILITY OF SHOP BUILDING STANDARDISATION

By D. Street.

SINCE the remarkable innovation of the standardisation of ships is now being seriously discussed, it seems not unreasonable to suppose that a similar improvement may yet embrace shop buildings. These may in the near future be standardised under the aegis of the economical intensive industry that must certainly follow the war. In England the way has been well prepared and smoothed by the work of the Engineering Standards Committee, who have standardised all the structural materials required. It may not be a long step from the materials to the buildings. It would merely transfer the work of design from the architect who may often have a superficial acquaintance with industrial requirements, to the people who make a speciality of such buildings. A great deal of tedious independent calculation could be saved, and calculation for a given kind of building of given proportions made for all parties. The basis of these are available in books of sections for various loadings, they would only have to be extended to the actual buildings. It would be merely an extension of the principle which is regularly utilized by builders of machine tools, cranes, automobiles, and so on.

The requirements of a firm being known, a standard design already being worked out, exactly or approximately suited to the firms requirements, could

be submitted without the delay entailed by getting out complete new plans. The work could be put in hand at once, and the building completed almost before the plan could be prepared by the general architect. Something of the kind is being done by firms who supply the steel skeletons for factories. It would only be necessary to extend it to include foundations, floors, lighting, etc. Alternative plans might be available for walls of masonry or concrete or corrugated sheet, for side windows or roof lights, for single floor buildings or storied buildings, to suit the varied requirements of firms. This kind of thing would grow, and the standard patterns multiply. Already one is aware, that when firms erect new buildings they now often adopt designs which by their similarity are pointing the way to standardisation. The extensions of existing buildings would also be greatly facilitated by such a system because it would only involve additional units already standardised. A few weeks would suffice for carrying out directions or extensions which normally occupy the same number of months. The actual cost would generally be less.

—❁—

A Rope Drive Puzzle.—In connection with rope driving the question is sometimes asked: "Why do some ropes revolve in the groove, while others do not?" In a paper on "Rope Driving," read recently by R. Edward Hart before the members of the Bradford Engineering Society, the author says this question has never been satisfactorily answered. It is reassuring, however, to learn from the paper that whether ropes revolve or not has very little to do with their longevity, as it is easy to point to both types which have worked well for many years. Some people, says the author, imagine that when a rope begins to revolve it is rapidly rubbing itself away; this is quite an erroneous view of things. As a matter of experience, the ropes which have the longest life are, in the majority of cases, quite circular in section. And when the ropes have been running for any length of time, it is always easier to tighten a round rope which has been worn evenly all over its surface than to attempt to resplice a rope which has worn V-shaped and taken all the wear on its two sides only. Some engineers prefer ropes to revolve, because they affirm that there is less frictional loss whilst leaving the groove with a round rope than with a V-shaped rope, maintaining that it partakes more of the nature of rolling friction.

—❁—

Walking through the village street one day, the widowed Lady Bountiful met old Farmer Stubbs on his way to market. Her greeting went unnoticed.

"Stubbs!" said she, indignantly. "You might at least raise your hat to me!"

"I beg your pardon, m'lady," was the reply, "but my poor wife ain't dead dead more'n two weeks, and I ain't started lookin' at the wimmen yet!"

PROGRESS IN NEW EQUIPMENT

A Record of New and Improved Machinery and Accessories for the Machine, Pattern, Boiler and Blacksmith Shops, Planing Mill, Foundry and Power Plant

12-IN. ROTARY SURFACE GRINDING MACHINE

THIS rotary surface grinding machine has been designed especially for the rapid and accurate finishing of flat surfaces, and has a capacity for work up to twelve inches in diameter, either a single piece or a number of smaller pieces as desired.

It is very compact and massive in construction, with large bearing surfaces, these features being necessary for the rapid and efficient removal of stock and the securing of surfaces with a high finish.

The design is entirely self-contained, requiring but a single belt from the main line, and thus doing away with all overhead countershafts and a multiplicity of belts.

The machines may be furnished motor driven if desired, the motor being located on a bracket at the rear, making the motor-driven machine also self-contained and providing in this way a very compact arrangement.

The grinding wheel is 12 in. dia. by 1 in. face, and is mounted in a very rigid wheel slide having two flat ways with taper gib adjustment. The bearing surfaces are unusually large and are carefully protected from grit and dirt. The belt pull on the wheel slide is downward, thereby adding to its stability. The grinding wheel spindle is large in diameter, and is furnished with a taper bearing running in a bronze bushing at the grinding wheel end and is carried in ball bearings at the rear end. The spindle, therefore, requires but one simple end-wise adjustment for the taking up of all wear.

Ample power is provided by the use

of large belts and the machine is able to remove large amounts of stock, as well as as producing a high quality of finish; the amount of stock which may be removed at one cut is only limited by the ability of the wheel to stand up under the work. In this machine the grinding is done by the periphery of the wheel, which is especially desirable if accuracy is desired, and a high quality of finish is important. Feed lines and radial scratches in the work are eliminated by using the grinding wheel in this manner.

The machine is provided with automatic feed for the wheel slide, so that the grinding wheel will automatically traverse over any portion of the chuck desired. A pilot wheel is provided for hand feed which might be preferred on certain classes of work, being disengaged at any time when the automatic feed is in use.

The machines are regularly equipped with a 12 in. Heald magnetic chuck, but they can be furnished if desired with a 10 in. or an 8 in. magnetic chuck; or if the work is not adapted to be held on magnetic chucks to the best advantage, three jaw chucks or face plates with holding fixtures can be substituted. The chuck is mounted on a vertical spindle so arranged that no adjustment for wear is required, this being automatically taken up. The chuck spindle is carried inside a sleeve which is raised or lowered by a threaded nut running on ball bearings, making it easy to adjust the chuck to any position required to suit the work being ground.

The work is fed to the wheel by means of a hand wheel with graduated dial. An automatic vertical feed is regularly furnished, as this is a desirable feature

when there is a considerable amount of stock to be removed, or when it is desirable to have one operator handle more than one machine. The chuck spindle is provided with an angular adjustment so that the machine will grind concave or convex surfaces up to an angle of five degrees. This feature is very desirable when grinding saws or cutters, and is also valuable in providing adjustment to enable the machine to grind absolutely flat surfaces even after long service.

The machine is regularly equipped with pump, tank and water guards and all connections for wet grinding. A liberal supply of water is delivered at the grinding point, and the guards are so designed as to thoroughly protect the operator and keep the water within the machine.

Particular attention might be called to the design of the gear box on the front of the machine which contains practically all of the mechanism for driving the chuck and the wheel slide at their different speeds. All the parts in this unit are easily accessible and the very simple and compact arrangement of this unit adds largely to the efficiency of the machine. Four changes of speed for the chuck and four changes of speed for the wheel slide are instantly obtained by simply turning a hand wheel; the chuck speeds and the wheel slide speeds are independent. This machine is built by the Heald Machine Co., Worcester, Mass.



AUTOMATIC TAPPER AND BENCH DRILL

AN AUTOMATIC tapping machine which also combines the functions of a bench

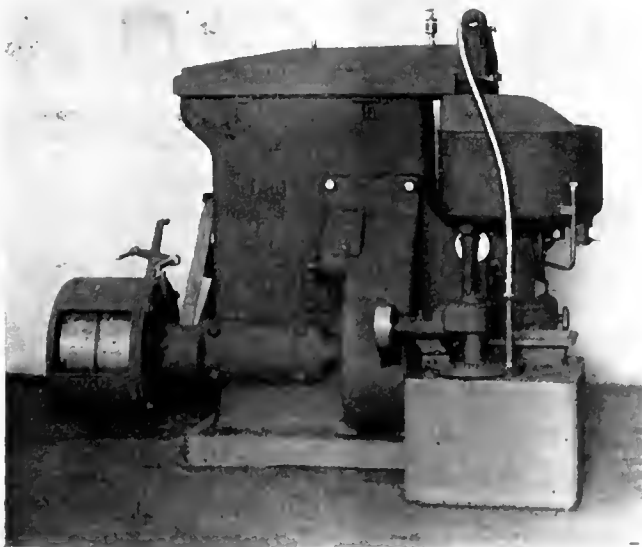

REAR SIDE OF SURFACE GRINDER, SHOWING DRIVE FROM PULLEY SHAFT TO GRINDING WHEEL SLIDE, ALSO WATER PUMP, ETC.

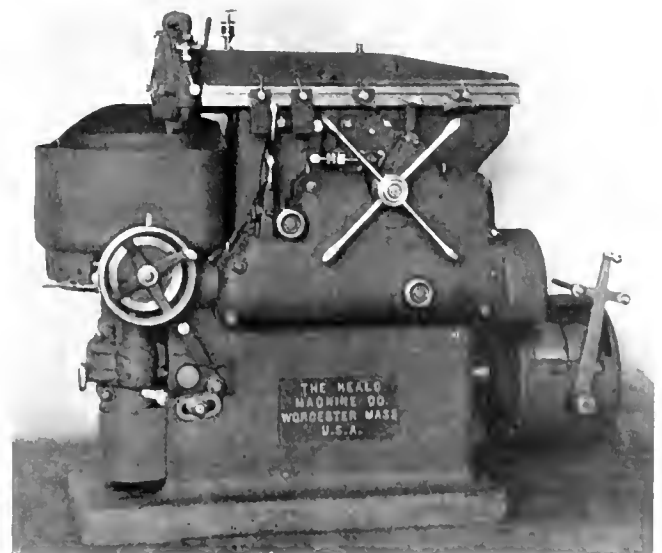

OPERATING SIDE OF SURFACE GRINDER SHOWING HAND FEED TO GRINDING WHEEL SLIDE AND VARIOUS CONTROL LEVERS

drill is shown in the accompanying engraving, being built by W. H. Simons & Co., Cincinnati, O. It is of compact and rigid design, with four-step cone pulley drive from self-contained countershaft, giving spindle speeds of 150, 250, 390, and 600 rev. per min. It drills on taps to the centre of a 12 in. circle. The maximum distance from spindle to table is 10½ in., the vertical adjustment of spindle being 3¼ in., and of the table, 5 in.

The spindle is equipped with a load for any desired pitch, 16, 18, 20, and 24 thread leads being standard equipment. The clutch and reversing mechanism can be set to run the tap to any desired depth reverse automatically, and, after the tap clears the work, the spindle stops automatically. All contact points throughout are hardened.

A belt tightening device is provided, being operated by a star grip on the side of the column, so that the cone belt can be adjusted to any tension desired. Bronze bearings are furnished throughout, and the pulleys on the lower shaft

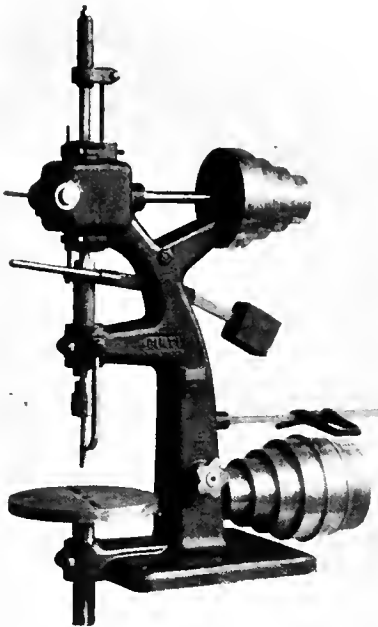

COMBINED BENCH DRILL AND AUTOMATIC TAPPER.

are bronze bushed. The tapping capacity of the machine is ¾ in. in cast iron, with a drilling capacity of ½ in. in the same material.



13 IN. ENGINE LATHE

THE lathe illustrated herewith has been placed on the market by the Philip Smith Mfg. Co., Sidney, O. It is of entirely new design and possesses ample power for the rated swing.

The headstock is of the solid full-webbed type; its rigidity and close adjustments prevent chattering on heavy cuts. The front spindle bearing is 4 x 2¾ in., and the rear, 3 x 1 13/16 in., both self-oiling, while a 1 15/16 in. hole is provided through the length of the spindle. The spindle is made of 50 point

carbon crucible steel, ground to size and fitted in phosphor bronze bearings.

The bed is wide and deep, with heavy

½ to 8 mm.; spindle speeds, 18, max., 600 min., 27 rev. per min.; net weight, 1,250 lbs.

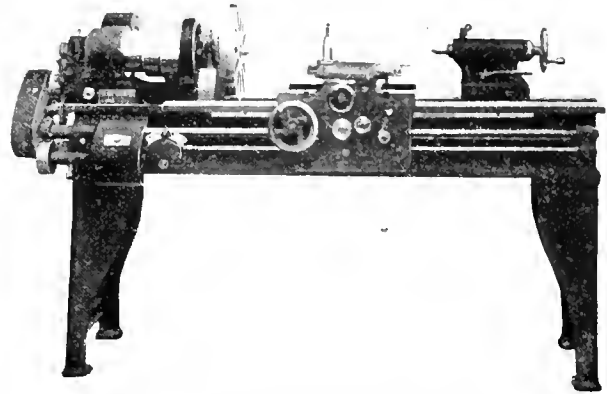

13" ENGINE LATHE WITH QUICK-CHANGE FEED AND DOUBLE BACK GEAR.

walls and large box girders. It is fitted with a carriage having a bearing 18 in. long on the vees; the bridge is 7¼ in. wide and tee slots are provided for clamping special work. The compound rest is unusually large and rigid, is provided with taper gibs, and graduated for angular work.

The apron is a one-piece casting, all bearings being integral; steel gears are used and all studs are hardened and ground. The half nuts have safety device to prevent unintentional engagement and graduated dials are on both cross-feed and compound rest. screws.

Quick change feed mechanism provides four changes of feed. All gears are guarded, one piece steel rack is fitted, all sliding surfaces scraped to a bearing and all cylindrical parts ground to size. Standard equipment consists of compound rest, follow rest, steady rest, double friction countershaft and wrenches. Special equipment includes drawn-in chucks of ⅝ and ⅞ in. capacity, taper attachments, automatic stops, chasing dial, etc., and bed lengths of 8 and 10 feet.

The machine with 6 ft. bed has speci-

AUTOMATIC MULTIPLE PLUNGER PRESS

SHEET metal work, which embraces the manufacture of such articles as eyelets, snap fasteners, pencil tips, primers, percussion caps, thimbles, buttons, ferrules, grease cups, and containers for drugs and toilet preparations, is produced successfully by the employment of multiple plunger presses of the type shown in the accompanying illustration. Rapidity of operation is a feature of these machines, the output ranging from 35,000 to 80,000 pieces per day of ten hours inclusive of time for repairs, setting up, sharpening tools, oiling, replenishing stock and other regular interruptions during running. The large variation in output covers all classes of work, the output for any particular article depending on the kind of material used, gauge, and dimensions of finished article. The actual speed varies from 65 rev. per min. to 150 rev. per min.

The type of machine illustrated will automatically cut a blank from sheet metal and carries the work along to the

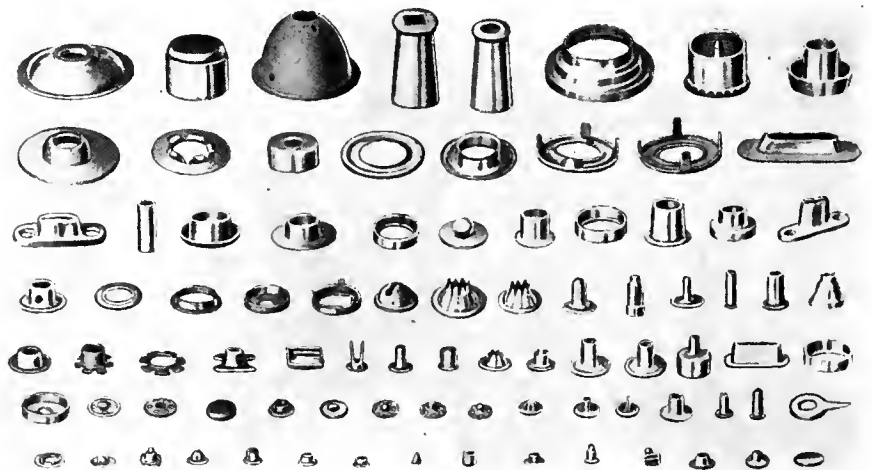

SPECIMENS OF WORK PRODUCED ON MULTIPLE PLUNGER PRESS.

fications as follows: Swing, over bed, 13¼ in.; over carriage, 8¼ in.; between centres, 35 in.; centres, Morse taper No. 3; cut threads, English, 4 to 20, metric,

successive operations under the other plungers, completing the part and performing such operations as piercing, forming, drawing, trimming, light

stamping or embossing, etc., producing complete parts automatically from the sheet stock without manual handling.

While the basic principle of the machine has been in use for many years, several improvements have been made in

but with a separate set of cams. This is done by the adjustable horizontal members shown above the cam shaft, and may be seen between the cam shaft and the upper cross member of the frame, and connected to the plungers by means of the vertical lifting rods at the back.

The machine operates as follows:—The metal which is in the strip form and coiled, is placed on the reel in front, passes through a lubricating pad and through a stripper over the blanking die to a feed roll mechanism in the back. This feed roll mechanism is operated by the intermittent ratchet, timed so as to co-ordinate with the operation of the press. While the strip stock is at rest in this position, the first plunger blanks out the piece and carries it through the die to a pocket in the transfer slide, a reel at the back reeling up the scrap stock after it leaves the feed rolls. The transfer slide moves from right to left by the action of the vertical crank shaft, this movement being equal to the center distances between the plungers. This action moves the blanked piece in the pocket in the transfer slide, along to the second plunger which carries the forming punch, and the second operation is performed by the punch in the second plunger, drawing the blanked piece through the transfer slide, and into the first forming die. The transfer slide now moves back from left to right, into its first position, so that it can move again from right to left, carrying the second blanked piece from the first plunger to the second position, and at the same time carrying the cupped piece from the second position to the third position.

This operation of carrying on to the next plunger, is repeated at each stroke of the press, until work has been carried

to the transfer slide where it drops into a pocket, by vertical ejector plungers, operated by the lower cam shaft, which is geared to operate in synchronism with the upper cam shaft, through the medium of mitre gears on the two cam shafts, and the vertical crank shaft. This will be seen in the illustration at the right of the machine. These lower plungers push the work up out of the die at the proper time, into the fingers of the transfer slide.

The transfer slide is fitted with these carriers or fingers, for each station, except the first station. These take hold of the piece like the thumb and index finger of the person's hand, and are the means of holding the parts when transferring to the succeeding operation. The machine is thus fully automatic in its operation, the attention of the attendant is only necessary to keep the stock reel supplied with stock, and to remove the boxes of finished work and small piercings, if any, replacing them with empty boxes, and one attendant can care for a dozen or more machines.

These machines are the product of the H. E. Harris Engineering Co., Bridgeport, Conn., the most general sizes being with four, six and seven plungers.

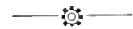

Mr. Flanagan attended a christening where the hospitality of the host knew no bounds. In the midst of the celebration Flanagan rose up and made the rounds of the company, bidding each a profound farewell.

But, Pat, man," objected the host, "you're not goin' yet, with the evening' just started?"

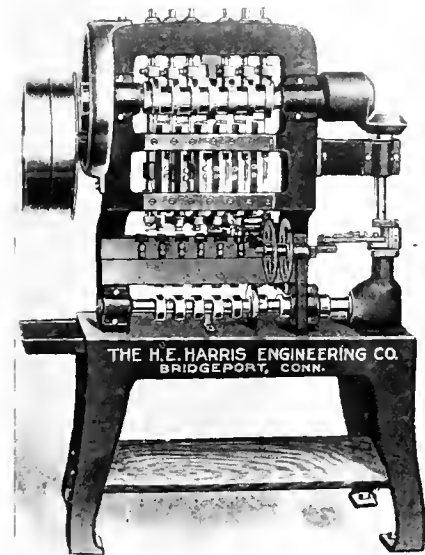

MULTIPLE PLUNGER PRESS FOR CONTINUOUS PRODUCTION OF SHEET METAL PARTS.

the last two years. The frame is off set at the left hand side, and provision is made for an extra die and for a double punch to be carried by the last plunger. In this way the press performs one more operation than the number of plungers. This is a distinctive feature, for if it becomes advisable to add an additional operation, such as stamping, a name or trade mark, or any other operation which becomes desirable after first planning, the provision for taking care of it in the machine is thus provided. All the operations are simultaneous; that is, with each revolution of the cam shaft, each one of the plungers performs an operation on the parts which are going through the press. The speed of operation and methods of performing the work do away entirely with annealing the parts between operations. The weight of the machine and the throw of the cam and other details are arranged to suit the parts to be manufactured in the press; likewise, the number of plungers are varied to suit the number of operations required to manufacture the piece.

The machine consists of a heavy main frame carrying a number of press plungers operated by a cam shaft which determines the timing and the throw of such plungers. These plungers carry the different punches for blanking, embossing, piercing, drawing, etc. The bolster fitted on the bottom part of the main frame, holds the different dies to suit the punches and carries the transfer slide.

The plungers are returned to their upward position after the operation of the punches upon the part by the same shaft,

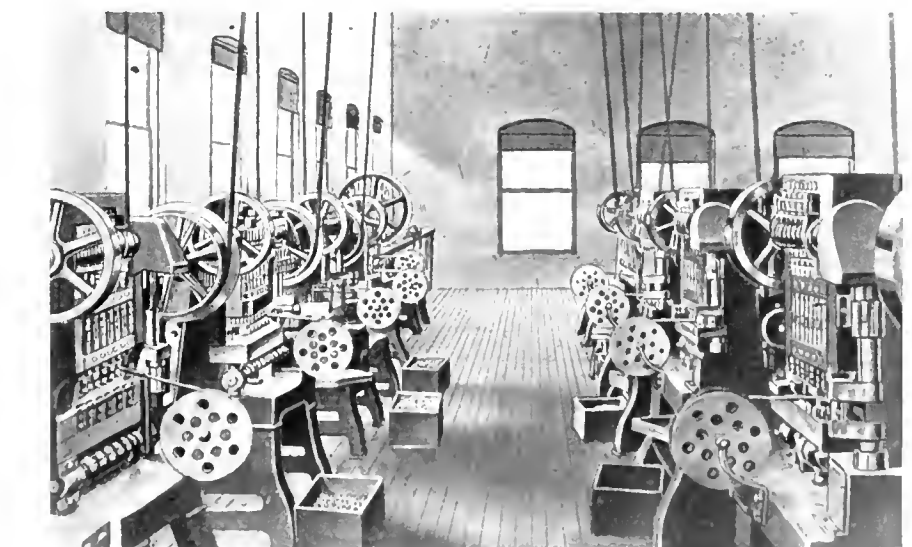

VIEW OF PRESS ROOM EQUIPPED WITH MULTIPLE PLUNGER PRESSES SLOWING REELS OF STOCK

along to the last plunger, when it is ejected and carried through a tube into a box or pan, set to receive the finished parts. The work is returned from the die, (with the exception of the first die.)

"No, said Pat, "but I'm buidin' ye good-night while I know ye all."

"Adam owned the earth at one time. His experience should be a warning to those who want it now."

The MacLean Publishing Company

LIMITED
(ESTABLISHED 1888)

JOHN BAYNE MACLEAN - - - - - President
H. T. HUNTER - - - - - Vice-President
H. V. TYRRELL - - - - - General Manager
PUBLISHERS OF

CANADIAN MACHINERY AND MANUFACTURING NEWS

A weekly newspaper devoted to the machinery and manufacturing interests.

PETER BAIN, M.E., Editor. B. G. NEWTON, Manager.
Associate Editors
A. G. WEBSTER J. M. WILSON J. H. RODGERS

Office of Publication, 143-153 University Avenue, Toronto, Ont.

Vol. XVII.

JUNE 21, 1917

No. 25

SOME FEATURES OF OUR MINERAL RESOURCES DEVELOPMENT

AS was to be expected, the pronounced manufacturing activity—metal-working and otherwise, which marked the year 1916, in Canada, was not without a parallel in her mineral recovery. The total production of marketable coal amounted to 14,461,678 short tons, valued at \$38,857,557, as against 13,267,023 short tons valued at \$32,111,182 in 1915, or an increase in quantity of 9 per cent., and in value of 21 per cent. The general industrial situation necessitated more and greater freight movement, thereby increasing the demand and stimulating production, particularly in Western Canada.

The output of oven coke during 1916 was 1,448,782 short tons, while that of 1915 was 1,200,766 short tons. The 1916 returns show a recovery of 67.9 per cent. of the total coal charged as compared with 64.7 per cent. in 1915. It should be noted that for the 1916 coke production, 1,501,835 short tons were of domestic origin, and 633,076 short tons were imported.

Pig-iron production during 1916—exclusive of ferro-alloys, amounted to 1,169,257 short tons, valued at \$16,750,903 as against 913,775 short tons valued at \$11,374,199 in 1915. The 1916 output of pig-iron established a record, the year 1913 with 1,128,967 short tons being our previous best. The value of the former as compared with the latter is naturally much higher, due to the increased price obtainable, in which connection, at the prices which have been ruling during the present year so far and likely to be well maintained during the ensuing six months, we may look for not only still further increased output, but a total value several millions of dollars higher comparatively.

Iron ore operations were almost wholly confined during 1916 to the Helen and Magpie Mines of the Algoma Steel Corporation, the total shipments being 339,600 short tons valued at \$814,044 as compared with 398,112 short tons valued at \$774,427 in 1915. Shipments of iron ore from Wabana Mines, Nfld., to Cape Breton, N.S., by the Dominion Steel Corporation, and Nova Scotia Steel & Coal Co., totalled 1,012,060 short tons. In 1915 802,128 short tons were shipped to Cape Breton and 66,323 tons to England.

The production of copper shows large increases during the past three years, due in great measure to the munitions demand. The comparative figures for Canadian ores mined in 1916 and 1915, showing returns from smelters of 119,770,814 pounds and 100,785,150 pounds respectively.

Nickel production totalled 82,958,564 pounds in 1916 as

compared with 68,308,657 pounds in 1915, or an increase of 21½ per cent. That of Cobalt amounted to 841,859 pounds as against 504,212 pounds in 1915. The recovery of lead was less during 1916 than during 1915, the comparative figures being 41,593,680 and 46,316,450 pounds respectively. The enhanced price obtained per pound made an increase of 32 per cent. value in favor of 1916, however.

With the exception of a small production in experimental work, there was no recovery of zinc spelter, or refined zinc in Canada previous to 1916. The establishment of an electrolytic zinc refinery at Trail, B.C., and of a zinc recovery plant at Shawinigan Falls, Que., has placed the metallurgy of this metal in Canada on a similar basis to that of lead and copper. In 1916 it is estimated that Canadian zinc ores produced 23,515,030 pounds of refined metal as against 12,231,439 pounds in 1915. The major portion of the refining was performed in United States smelters in the former year, and all of it in the latter, but expectations are that when the figures for 1917 come to be compiled, the bulk of the refining will be credited to Canadian smelters.

From the data given, which treats only of the more prominent minerals and their reduction to a state which admits of their easy adaptation to the needs of our metal-working and kindred industries, so to speak, it will be apparent that research into and utilization of our natural resources have made gigantic strides during this war time, and bid fair to ensure our not only being able to extract expeditiously and profitably the mineral wealth, which we possess, but so deal with it as that only in manufactured form shall it go beyond our borders.



THE OUTLOOK

AS an indication of the attitude of one of our most prominent industrial executives, the address of Col. Thomas Cantley at the recent annual convention of the Canadian Manufacturers' Association in Winnipeg, is worthy of close study and careful consideration.

The necessity of maintaining Canada's industrial organization at the highest possible level is apparent to the most casual observer of passing events and present conditions. A sudden collapse of manufacturing activity, say in Ontario alone, would be disastrous indeed, and the advocacy of a sound fiscal policy to stimulate supplying "our own wants and produce in addition something exchangeable at a profit for such commodities as we do not grow or cannot produce," is worthy of generous response.

Complementary to the development of export trade, the desirability of a future Canadian mercantile marine is daily becoming more evident. The percentage of foreign-owned bottoms which in pre-war times prevailed in the St. Lawrence, should be looked on as utterly incompatible with the free, healthy growth of our Dominion world trade. Circumstances enabled the speaker to appreciate to the full the value of such an industry as shipbuilding to this country. Apart from its intrinsic value as such, the successful establishment of shipbuilding is sure to be accompanied by much activity in subsidiary lines.

The widely varying industries of the Dominion are well exemplified by the personality of S. R. Parsons, the newly-elected President of the Association. Paper and oil are somewhat of a contrast to iron and coal, but their prominence is little, if any, less. To attain success, such as Mr. Parsons has, betrays an ability far-reaching and persistent, and under his *aegis* the Canadian Manufacturers' Association may be expected to continue its good work of solidifying the efforts of our industrial interests, extending their scope and directing their policies so that the greatest good will result for the greatest number, nationally as well as individually.

INDUSTRIAL NOTABILITIES

S. R. PARSONS, president, British American Oil Company, Ltd., Toronto, was born in Port Hope, Ont., Aug. 4, 1854, son of William and Margaret (Trick) Parsons.

He received his education at Port Hope Grammar School, and migrated to Winnipeg as a young man, engaging in the wholesale stationery business as senior partner of Parsons, Bell & Co., which ultimately became merged with the Consolidated Stationery Co., Ltd., of which he was president for some years. His residence in Winnipeg extended over sixteen years and was terminated by an illness which necessitated a change of climate, resulting in his removal to Toronto and his establishing the present business in 1906.

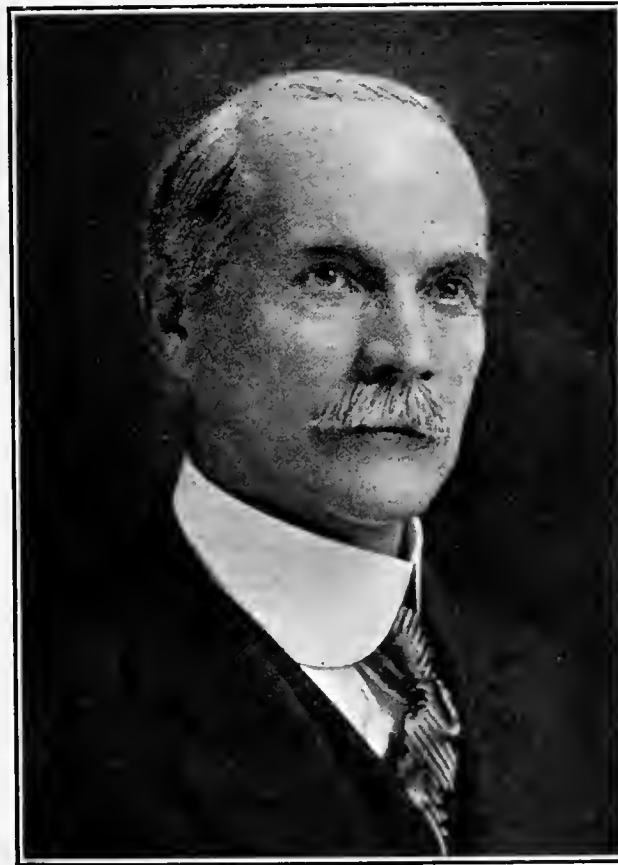

S. R. PARSONS.

Mr. Parsons has been chairman, Ontario board of directors, Canadian Fire Insurance Co., since 1900; was elected chairman of the transportation committee, Canadian Manufacturers' Association for four successive years (1911-1915); elected second vice-president of the Association, 1915; first vice-president, 1916; president, 1917. Was also director of the Riverdale Business Men's Association for several years prior to 1913, and is still a member of that organization.

He has taken much interest in social, religious and philanthropic work in Toronto and was active in recruiting with the C.M.A. during the war. The Methodist Social Union received his guidance as a director for a number of years.

In 1882, Mr. Parsons married Annie Kate Helliwell, daughter of Rev. Thomas L. Helliwell, Winnipeg, their family consisting of three daughters.

Mr. Parsons resides at 139 Crescent Road, Toronto; is Independent in political creed, and Methodist in religion.

Photo, Courtesy British and Colonial Press.

SELECTED MARKET QUOTATIONS

Being a record of prices current on raw and finished material entering into the manufacture of mechanical and general engineering products.

FIG IRON.

Grey forge, Pittsburgh.....	\$47 95
Lake Superior, charcoal, Chicago	52 00
Standard low phos., Philadelphia	80 00
Bessemer, Pittsburgh	55 95
Basic, Valley furnace	50 00
Montreal Toronto	
Hamilton	
Victoria	

FINISHED IRON AND STEEL.

Per lb. to Large Buyers Cents	
Iron bars, base, Toronto	5 00
Steel bars, base, Toronto	5 25
Steel bars, 2 in. to 4 in. base	6 00
Steel bars, 4 in. and larger base	7 00
iron bars, base, Montreal	4 75
Steel bars, base, Montreal	5 00
Reinforcing bars, base	5 25
Steel hoops	7 50
Bessemer rails, heavy, at mill	38 00
Steel bars, Pittsburgh	4 25
Tank plates, Pittsburgh	8 00
Structural shapes, Pittsburgh	4 25
Steel hoops, Pittsburgh	5 25
F.O.B. Toronto Warehouse	
Steel bars	5 00
Small shapes	5 50
F.O.B. Chicago Warehouse	
Steel bars	5 00
Structural shapes	5 00
Plates	8 50

FREIGHT RATES.

Pittsburgh to Following Points	
Per 100 lbs.	
	C.L. L.C.L.
Montreal	23.1 31.5
St. John, N.B.	35.1 45.5
Hatifax	35.1 45.5
Toronto	18.9 22.1
Guelph	18.9 22.1
Loudoo	18.9 22.1
Windsor	18.9 22.1
Winnipeg	64.9 85.1

METALS.

Montreal Toronto	
Lake copper	\$37 50 \$37 00
Electro copper	37 50 37 00
Castings, copper	36 50 36 00
Tin	62 50 66 00
Spelter	12 00 12 00
Lead	14 00 14 25
Antimony	25 00 26 00
Aluminum	70 00 68 00
Prices per 100 lbs.	

PLATES.

Montreal Toronto	
Plates, 1/4 to 1/2	\$10 00 \$10 00
Heads	10 30 10 30
Tank plates, 3-16 in.	10 10 10 10

WROUGHT PIPE.

Effective May 14, 1917.	
Black Galvanized	
Standard Buttwd.	
Size.	Per 100 feet
1/4 in.	\$ 4 50 \$ 6 00
1/2 in.	4 96 7 00
3/8 in.	4 96 7 00
1/2 in.	6 29 7 86
3/4 in.	7 94 10 06
1 in.	11 73 14 88
1 1/4 in.	15 87 20 13
1 1/2 in.	18 98 24 06
2 in.	25 53 32 38
2 1/2 in.	40 95 51 77
3 in.	53 55 67 70
3 1/2 in.	66 24 83 26
4 in.	78 48 98 65
Standard Lapweld.	
2 in.	28 49 34 97
2 1/2 in.	42 71 52 94
3 in.	55 85 69 23

3 1/2 in.	68 08	86 02
4 in.	80 66	101 90
4 1/2 in.	93 98	118 70
5 in.	109 50	138 40
6 in.	142 10	179 50
7 in.	185 60	232 05
8 L in.	195 00	243 75
8 in.	224 60	280 80
9 in.	269 10	336 38
10 L in.	249 60	312 00
10 in.	321 40	401 70

Prices—Ontario, Quebec and Maritime Provinces.

WROUGHT NIPPLES.

4" and under, 50%.	
4 1/2" and larger, 45%.	
4" and under, running thread, 30%.	
Standard couplings, 4" and under, 40%.	
4 1/2" and larger, 20%.	

OLD MATERIAL.

Dealers' Buying Prices.	
Montreal Toronto	
Copper, light	\$22 00 \$22 00
Copper, crucible	26 00 27 00
Copper, heavy	26 00 26 50
Copper wire	26 00 26 50
No. 1 machine com-	
position	22 50 22 00
New brass clippings	18 00 19 00
No. 1 brass turnings	16 00 16 00
Heavy melting steel	19 00 17 00
Steel turnings	9 00 8 00
Shell turnings	12 00 12 00
Boiler plate	15 00 10 50
Axles, wrought iron	22 00 24 00
Rails	19 00 18 00
No. 1 machine cast	
iron	24 00 25 00
Malleable scrap	29 00 20 00
Pipe, wrought	17 00 9 00
Scrap zinc	8 00 9 50
Heavy lead	11 50 10 75
Tea lead	7 50 7 00
Aluminum	35 00 35 00

BOLTS, NUTS AND SCREWS.

Per Cent.	
Coach and lag screws	25
Stove bolts	55
Plate washers	net list
Machine bolts, 7-16 and over	net
Machine bolts, 3/8 and less	10
Blank bolts	net
Bolt ends	net
Elevator bolts	50 and 5
Machine screws, fl. and rd. hd., steel	27 1/2
Machine screws, o. and fl. hd., steel	10
Machine screws, fl. and rd. hd., brass	add 20
Machine screws, o. and fl. hd., brass	add 25
Nuts, square blank	add \$1 50
Nuts, square, tapped	add 1 75
Nuts, hex. blank	add 1 75
Nuts, hex. tapped	add 2 00
Copper rivets and burrs, list plus	30
Burrs only list plus	50
Iron rivets and burrs	17 1/2
Boiler rivets, base 3/4-in. and larger	\$7 10
Structural rivets, as above	7 00
Wood screws, flat, bright	72 1/2
Wood screws, O. & R., bright	67 1/2
Wood screws, flat, brass	37 1/2
Wood screws, O. & R. brass	32 1/2
Wood screws, flat, bronze	27 1/2
Wood screws, O. & R. bronze	25

MILLED PRODUCTS.

Per cent.	
Set screws	35
Sq. & Hex. Head Cap Screws	30
Rd. & Fl. Head Cap Screws	10
Flat 3/8 But. Hd. Cap Screws plus	10
Fin. & Semi-fin. nuts up to 1 in.	25
Fin. and semi-fin. nuts, over 1 in., up to 1 1/2 in.	30
Fin. and semi-fin. nuts, over 1 1/2 in., up to 2 in.	10
Studs	20
Taper pins	40
Coupling bolts, plus	10
Planer head bolts, without fillet, list plus	10
Planer head bolts, with fillet, list plus 10 and	10
Planer head bolt nuts, same as finished nuts.	
Planer bolt washers	net
Hollow set screws	list plus 20
Collar screws	list plus 30, 10
Thumb screws	20
Thumb nuts	65
Patch bolts	add 40, 10
Cold pressed nuts to 1 1/2 in.	add \$4.50
Cold pressed nuts over 1 1/2 in.	add \$7.00

BILLETS.

Per gross ton	
Bessemer billets	\$100 00
Open-hearth billets	100 00
O.H. sheet bars	105 00
Forging billets	125 00
Wire rods	95 00
F.o.b. Pittsburgh.	

NAILS AND SPIKES.

Wire nails	5 00	4 95
Cut nails	5 35	5 35
Miscellaneous wire nails		60%
Spikes, 3/4 in. and larger	6 50	
Spikes, 1/4 and 5-16 in.	7 00	

MISCELLANEOUS.

Solder, strictly	0 38
Solder, guaranteed	0 41
Babbitt metals	16 to 65
Soldering coppers, lb.	0 53
Putty, 100-lb. drum	4 35
White lead, pure, cwt.	19 00
Red dry lead, 100-lb. kegs, per cwt.	13 87
Glue, English	0 38
Tarred slaters' paper, roll	0 93
Gasoline, per gal., bulk	0 31 1/2
Benzine, per gal., bulk	0 30 1/2
Pure turpentine, single bbls., gal.	0 65
Linseed oil, raw, single bbls.	1 40
Linseed oil, boiled, single bbls.	1 43
Plaster of Paris, per bbl.	2 50
Plumbers' oakum, per cwt.	9 00
Packing, square braided	0 32
Packing, No. 1 Italian	0 38
Packing, No. 2 Italian	0 30
Lead wool, per lb.	0 15
Pure Manila rope	0 37
Transmission rope, Manila	0 43
Drilling cables, Manila	0 39

POLISHED DRILL ROD.

Discount off list, Montreal and Toronto	25%
---	-----

CARBON DRILLS AND REAMERS.

Per Cent.	
S.S. drills, wire sizes up to 52	40
S.S. drills, wire sizes, No. 53 to 80	25
Standard drills to 1 1/2 in.	40
Standard drills, over 1 1/2 in.	15
3-fluted drills, plus	10
Jobbers' and letter sizes	40
Bit stock	40
Ratchet drills	15
S.S. drills for wood	40
Wood boring brace drills	25
Electricians' bits	30
Sockets	40

Sleeves	40
Taper pio reamers	20
Drills and countersinks	
Bridge reamers	list plus 30
Centre reamers	45
Chucking reamers	10
Hand reamers	15

COLD ROLLED SHAFTING.

At mill	list plus 40%
At warehouse	list plus 50%
Discounts off new list. Warehouse price at Montreal and Toronto.	

IRON PIPE FITTINGS.

Canadian malleable, A, add 10%; B and C, 10%; cast iron, 35%; standard bushings, 50%; headers, 60; flanged unions, 40; malleable bushings, 50; nipples, 55; malleable flpped unions, 50.	
--	--

SHEETS.

Montreal Toronto	
Sheets, Black, No. 28	\$10 00 \$ 9 60
Sheets, Black, No. 10	9 50 9 25
Canada plates, dull, 52 sheets	8 50 8 50
Canada plates, all bright	9 50 9 50
Apollo brand, 10 3/4 oz galvanized	9 75 9 75
Queen's Head, 28 B W.G.	10 75 10 75
Fleur-de-Lis, 28 B.W.	10 75 10 75
Gorbal's Best, No. 28	10 25 10 25
Colborne Crown, No. 28	10 00 10 00
Premier, No. 28 U.S.	10 90 10 70
Premier, 10 3/4 oz.	11 10 11 00

PROOF COIL CHAIN.

B	
1/4 in.	\$10 75
5-16 in.	10 40
3/8 in.	10 25
7-16 in.	10 00
1/2 in.	9 90
9-16 in.	9 90
5/8 in.	9 75
3/4 in.	9 50
7/8 in.	9 40
1 inch	9 25
Extra for B.B. Chain	1 20
Extra for B.B.B. Chain	1 80

ELECTRIC WELD COIL CHAIN B.B.

1/8 in.	\$15 50
3-16 in.	11 70
1/4 in.	8 40
5-16 in.	7 40
3/8 in.	6 35
7-16 in.	6 35
1/2 in.	6 35
5/8 in.	6 35
3/4 in.	6 35

Prices per 100 lbs.

FILES AND RASPS.

Per Cent.	
Great Western, American	55
Kearney & Foot, Arcade	55
J. Barton Smith, Eagle	55
McClelland, Globe	55
Whitman & Barnes	55
Black Diamond	45
Delta Files	40, 5
Nicholson	45
Globe	55
Vulcan	55
Disston	55

COAL AND COKE.

Solvay Foundry Coke	\$10 90
Connellsville Foundry Coke	
Steam Lump Coal	8 50
Best Slack	8 05
Net ton f.o.b. Toronto	

BOILER TUBES.

Size.	Seamless	Lap-welded
1 in.	\$33 00
1 1/4 in.	36 00
1 1/2 in.	38 00	32 00
1 3/4 in.	38 00	32 00
2 in.	45 00	33 00
2 1/4 in.	48 00	35 00
2 1/2 in.	50 00	38 00
3 in.	58 00	45 00
3 1/4 in.	53 00
3 1/2 in.	70 00	55 00
4 in.	82 00	67 00

Prices per 100 feet, Montreal and Toronto.

OILS AND COMPOUNDS.

Castor oil, per lb.	35
Royalite, per gal., bulk.	16
Palacine	19
Machine oil, per gal.	26 1/2
Black oil, per gal.	13
Cylinder oil, Capital	45 1/2
Cylinder oil, Acme	34 1/2
Standard cutting compound, per lb.	15
Lard oil, per gal.	1 45
Union thread cutting oil antiseptic	68
Acme cutting oil, antiseptic	37 1/2
Imperial quenching oil	39 1/2
Petroleum fuel oil	11

BELTING—NO. 1 OAK TANNED.

Extra heavy, single and double	30-5%
Standard	40%
Cut leather lacing, No.1	1 50
Leather in sides	1 35

TAPES.

Chesterman Metallic, 50 ft.	\$2 00
Lufkin Metallic, 603, 50 ft.	2 00
Admiral Steel Tape, 50 ft.	2 75
Admiral Steel Tape, 100 ft.	4 45
Major Jun. Steel Tape, 50 ft.	3 50
Rival Steel Tape, 50 ft.	2 75
Rival Steel Tape, 100 ft.	4 45
Reliable Jun. Steel Tape, 50 ft.	3 50

WASTE.

White	Cents per lb.
XXX Extra	20
Peerless	20
Grand	19
Superior	19
X L C R	18
Atlas	18
X Empire	18
Ideal	17
X press	16

COLORED.

Lion	14 1/2
Standard	13
No. 1	13
Popular	11 3/4
Keen	10 1/2

WOOL PACKING.

Arrow	25
Axle	20
Anvil	15
Anchor	11

WASHED WIPERS.

Select White	12
Mixed colored	10
Dark colored	09

This list subject to trade discount for quantity.

RUBBER BELTING.

Standard	40%
Best grades	20%

ANODES.

Nickel	.50 to .54
Cobalt	1.75 to 2.00
Copper	.44 to .46
Tin	.49 to .54
Zinc	.23 to .25

Prices Per Lb.

COPPER SHEETS.

Montreal Toronto	
Bars, 1/2 to 2 in.	55 00 53 00
Plain sheets, 14 oz., 14x28 in., 14x60 in.	55 00 53 50
Copper sheet, tinned, 14x60, 14 oz.	60 00 54 25
Copper sheet, plain, 14x60 base.	64 00 60 00
Braziers', in sheets, 6x4 base	55 00 52 00

BRASS.

Brass rods, base 1/2 in to 1 in rd.	0 55
Brass sheets, 8 in. wide, 20 oz.	0 60
Brass tubing, seamless	0 57
Copper tubing, seamless	0 58

PLATING SUPPLIES.

Polishing wheels, felt.	2 50
Polishing wheels, bull-neck	1 35
Emery in kegs, American	06
Pumice, ground	04
Emery glue	15 to 20
Tripoli composition	04 to 06
Crocus composition	07 to 08
Emery composition	08 to 09
Rouge, silver	35 to 50
Rouge, powder	30 to 35

Prices Per Lb.

LEAD SHEETS.

Montreal Toronto	
Sheets, 3 lbs. sq. ft.	\$18 00 \$18 00

Sheets, 3 1/2 lbs. sq. ft.	18 00	18 00
Sheets, 4 to 6 lbs. sq. ft.	17 50	17 50
Cut sheets, 1/2 lb. extra		
Cut sheets to size, 1 lb. per lb. extra.		

PLATING CHEMICALS.

Acid, boracic	\$ 15
Acid, hydrochloric	06
Acid, hydrofluoric	14 1/2
Acid, nitric	10
Acid, sulphuric	05
Ammonia, aqua	08
Ammonium carbonate	15
Ammonium chloride	11
Ammonium hydr. sulphuret	40
Ammonium sulphate	07
Araenic, white	12
Copper, carbonate, anhyd.	35
Copper, sulphate	17
Cobalt sulphate	70
Iron perchloride	20
Lead acetate	16
Nickel ammonium sulphate	12
Nickel carbonate	35
Nickel sulphate	15
Potassium carbonate	75
Potassium sulphide (substitute)	20
Silver chloride (per oz.)	65
Silver nitrate (per oz.)	55
Sodium bisulphite	10
Sodium carbonate crystals	65
Sodium cyanide, 127-130%	41
Sodium hydrate	04
Sodium hyposulphite, per 100 lbs.	5 00
Sodium phosphate	14
Tin chloride	60
Zinc chloride	60
Zinc sulphate	09

Prices Per Lb. Unless Otherwise Stated.

The General Market Condition and Tendency

THAT further advances in prices of steel products are assured is indicated by conditions prevailing in the steel market in the United States. Notwithstanding the present abnormally high level, prices continue to climb and no one knows when the present movement will stop. The shortage of steel is becoming more acute. Owing to the urgent demand for steel for war purposes, private consumers have to take material when they can get it, not when they want it. Warehouse stocks also are low, which makes the situation more difficult for the manufacturing consumer who used to rely on the warehouse for prompt delivery. The abnormal high price of pig-iron cannot help but ultimately affect prices of steel in addition to other influences. Several grades of pig-iron in the United States have now reached the \$50 mark and are still climbing. The coke situation continues to cause considerable anxiety to both the steel mills and furnaces by reason of the difficulty of obtaining sufficiently large quantities. Prices are also very high. There is no noticeable improvement at present in the coal situation, although it is hoped that conditions may become more favorable in time. The scrap metal market is dull, the only material showing any real activity being heavy melting steel. Scrap prices are unchanged on the basis of last week's quotations. The demand for scrap with the already named exception is light. Prices of non-ferrous metals are unchanged from last week, but the markets for the most part are firm, due largely to the expectation of increased demand rather than to any active buying at the present time. There is a fair demand for machine tools for general purposes, but the market is inclined to be quiet.

Montreal, Que., June 18, 1917.—Industrial conditions are again emphatically reflected in the continued advance of pig iron and steel products. In addition to the higher cost of all raw materials, there is the possibility that an early shortage may develop in certain lines when the full requirements of the

American Government are announced, which may have the resultant effect of curtailing the output that can be used for commercial purposes; this latter feature however, has shown considerable falling off during the past few months, due no doubt to the exorbitant prices asked and the enormous cost entailed

for general manufacturing purposes. The production of munitions proceeds with unabated energy but the demands for equipment are not heavy. Other lines of activity are improving, especially shipbuilding and marine accessories, many plants for the manufacture of the latter having been recently established.

Pig Iron

The problem of how to supply the demand, is the outstanding feature of the iron and steel situation, and the run-away market continues, with quotations on the various grades climbing higher and higher. Activities throughout the States in connection with the war, have greatly increased the pressure upon the producing mills and smelters, with the result that prices on all commodities have been subjected to sharp and continual advances and it is reasonably expected that further advances will follow the increasing requirements for the United States Government. American pig iron in general, has again been advanced during the week. Canadian pig is virtually off the market and quotations are withdrawn.

Steel

The uncertainty of present industrial conditions seems to feature the general situation, but the assurance of a stronger and higher market appears to be a foregone conclusion, as the supply of raw and finished material is falling below the increasing requirements of the trade. A factor that may have considerable bearing upon the early future of the steel market is the fact that material such as, plates, shapes and bars, which had been reserved for the United

States Government at a price approximately 2.9c, has been allotted to the trade for other requirements, and it is anticipated that, owing to the rapid advance in pig iron during the past several months, additional contracts entered into by the American Government will be made on a much higher basis than that originally expected. The unprecedented upward movement in basic pig can only have one result, that is, a corresponding advance in semi-finished and finished materials. The ship building program, more especially across the line, is attaining such enormous proportions that the full capacity of present mills will be inadequate to meet the full requirements of the shipping interests, without the curtailment of commercial demands upon this particular grade of steel. Dealers here advise that during the past two months, the sales for strictly commercial purposes has gradually decreased, and it is further expected that outside of actual war requirements, the demands for the immediate future respecting private enterprise will be greatly reduced if not entirely disappear. Under existing conditions, with the cost of materials rapidly advancing, the expenditure for domestic purposes will be almost prohibitive, apart from the difficulty of securing the desired material. Pittsburgh prices on unfinished steel have again been advanced, this week's quotations showing a rise of \$5 per ton. A sharp advance of about \$25 per ton has been placed on forging billets and sales have been recorded as high as \$135 per ton. Current quotations, f.o.b. Pittsburgh, are given in the selected market quotations. The market in plates is very strong owing to the heavy requirements for shipbuilding and car purposes, but some relief is expected within the next six months, as the production facilities are gradually being increased. The Pittsburgh price on black and blue annealed sheets has been advanced ½c per lb., the base quotation being approximately 8 cents per pound. Some relief has been given to the tin plate situation by the cutting off of supplies to the majority of these establishments manufacturing non-perishable goods, and reserving greater quantities for purposes where the use of tin plate is indispensable. Local dealers are looking forward to an early revision of sheet and tin plate prices. It is predicted that further advances in wire rods and wire products may be made within a short time, owing to the changing conditions of the market in raw materials. The sold up condition of the wrought iron and boiler tube mills maintains these markets in a very strong position, with the general tendency in an upward direction. The coke situation continues to be a factor in the production problem the quotation of \$11 for spot furnace, and \$12 for spot foundry is about \$1 above that of the previous week.

Metals

The market generally has been quiet and inactive, and with the exception of

lead might be said to have developed a weaker tendency. The situation is still influenced by the delayed action of the American Government, and uncertainty prevails. Copper is comparatively quiet with an easier tendency. Tin is inactive but firm, the trade awaiting the outcome of present permit negotiations. Dullness characterizes the spelter market and prices have declined. Lead is still the feature metal, the strength being reflected in another advance in price. Antimony has again weakened with a drop in price. Aluminum is firm and unchanged.

Copper.—There is no general change in the position of copper, and the American trade is awaiting the outcome of special conferences now being held by the large producers, regarding the price that should be paid by the government for future requirements. While the original understanding was that a year's supply would be arranged for at about 17c, there is a feeling that the quotation for additional copper should be closer to the present market, owing to the changed conditions and the fact that it costs small producers more to place metal on the market than the price first quoted. The London and New York markets continue firm with New York electro ¼c lower than last week. The local market is slightly easier with a one cent decline; lake and electro are quoted at 37½c, and castings at 36½c per lb.

Tin.—Interest is centered in the developments that are progressing between the Governments of the United States and Britain, to arrange for an adequate supply of tin for the future requirements of tin plate in the former country. The principal factor in this connection is the assurance that supplies of tin will not be hoarded for speculative purposes, but the requirements of the trade will be fully met, thus permitting the maximum production of essential tin supplies. A scarcity of spot metal has developed on the London market and prices for early positions have advanced but futures are easier. New York is a little stronger, an advance of one cent placing the spot price at 62c per lb. The local market is firm and unchanged at 62½c per lb.

Spelter.—The quiet market of the past week has developed into dullness and the situation has become somewhat easier, with prices on the decline. The demand is light and uncertainty prevails owing to the delayed action of the United States authorities. The New York market has declined ¼c during the week, while local dealers report a very quiet situation and quotations are marked down 1½c, the price asked being 12c per lb.

Lead.—Heavy demand and short supply have again been the cause of a slight strengthening of the lead market. The leading producers have practically been out of the market for some time and resale metal is less in evidence. Independents are quoting the nominal price of 12¼c, this being an advance over

last week of ¼c per lb. Dealers here continue to quote 14c on a strong and steady market.

Antimony.—On declining demand and plenty of metal, the market has developed further weakness and prices have become easier. The quotation of 20c on the New York market shows a decline of one cent on the week. The local situation is quiet but firm with an easier undertone.

Machine Tools and Supplies

No new features have developed in the machine tool situation and the market continues to be one of steady activity but of a more normal character. The demands for shell making equipment have shown a falling off although some business continues to be placed for single machines or additional equipment to increase the present capacity. Inquiries for second hand tools, suitable for marine work, is occupying the attention of machine tool dealers, as many plants throughout the country are contemplating the manufacture of certain incidentals necessary for boat equipment. As the shipbuilding operations become further advanced, it is expected that activities in this direction will receive additional impetus. As would be expected under existing conditions, the cost of machine tool production is constantly advancing and in order to maintain a balance, the cost of equipment to the user is constantly becoming higher; this feature of the situation being likely to become more pronounced in the early future. The demand for all classes of supplies continues heavy, but prices are constantly advancing to meet the higher costs of raw materials and manufacture.

Scrap

While no apparent change has taken place in the general situation to warrant the sharp advance recently made on the New York market, the quotations would appear to indicate a much stronger market, but this may be partly accounted for by the heavy advances noted on the quotations of steel and iron, and the expectations of some large producers of scrap who desire to receive more for their supply than would be justified by actual conditions. However, the market is undoubtedly firmer, especially in iron and steel scraps, the average advance of the past week being about 3c or 4c per lb. The Pittsburgh price for sheet bar crops is now \$48 per ton. Local price changes have been confined to boiler plate, machine cast iron and wrought iron pipe; the advances being 4c on the two former and 3c on the latter, the quotations being 15c, 24c and 17c respectively.

Toronto, Ont., June 19.—By the appointment of a fuel controller, it is hoped that the present unsatisfactory conditions in the coal trade will be eliminated. At present, prices are too high, and the shortage, although not acute, is very inconvenient, particularly to manufacturers. It is likely that the situation will have considerably improved by the

fall. The recent orders for cars placed by the Dominion Government will do much to revive the car building industry as well as relieve the transportation situation. When financial conditions become more favorable there will be important orders placed for railroad equipment of all kinds, as both locomotives and cars are badly needed.

Steel

President Mark Workman's statement regarding the affairs of the Dominion Steel Corporation, reveals a very interesting state of affairs and shows that this concern is enjoying a wonderful period of prosperity. Incidentally it reflects the activity prevailing in the steel industry in Canada, which is an encouraging feature in that the steel trade is usually considered to be the barometer of trade generally. The corporation is booked up for fifteen months, and the unfilled tonnage is almost double that for the corresponding period of last year, all of which contains a non-cancellation clause. This concern's shell steel output for the first six months of 1918 has been disposed of. The expansion in the steel industry in Canada is further indicated by a statement recently issued from Ottawa covering the first quarter of this year. The production of steel ingots and castings reached a new high level at 152,368 tons in March. The total production of 403,880 tons for the three months compares with 589,553 tons for the first six months of 1916.

High prices and backward deliveries continue to be the outstanding features in the steel trade. Although there is no indication when the upward movement in prices is likely to come to a stop, some authorities believe that this is not far distant. The situation, however, will not be affected to any great extent by the uncertainty as to what may develop as regards prices, as buying is for the most part of the hand-to-mouth order. Consumers now have to get steel when and where they can. Warehouse stocks are very low, and mill deliveries are very uncertain. Steel prices are largely nominal on account of the conditions prevailing, and fluctuations occur almost daily. Boiler tubes have taken another advance, being approximately 10 per cent. on seamless and 5 per cent. on lapwelded tubes. Current prices are, however, entirely nominal. Makers of both iron and steel tubes are sold up for a year or more ahead, but any mill that can spare tubes for reasonably prompt delivery can get any price it asks. Rivets have advanced; boiler rivets being now quoted at \$7.10 and structural at \$7 base. The demand for steel plates has been intensified by the American Government requirements for shipbuilding purposes. The market is very strong, and a further advance is expected before long. Prices of wrought pipe continue very firm, and an advance is likely in the near future. An advance in wire and wire products is expected soon.

The sheet market continues very strong and further advances are expected at an early date. The placing of tonnage for war requirements in the States is the

principal activity in the market. On this account very few sheet makers are figuring in the market, and they are offering only limited quantities at high prices. Mill capacities have been mobilized to serve the Government which is taking surplus stocks ordinarily available for nearby shipments.

The sharp advance in prices of pig iron in the United States continues, and with no abatement of the excited conditions prevailing. Prices of all steel products are also advancing and the end is not in sight. The American Government and the Allies' requirements of steel will probably range from 25 to 40 per cent. of the country's output, according to estimates. The principal advances this week include billets, sheet bars, structural shapes, steel hoops and wire rods.

Pig Iron

The pig iron market is unsettled by the extraordinary high prices now prevailing, and consumers are now in search of suitable grades to substitute for those which have become exceptionally scarce or risen beyond the means of the buyer to purchase. The coke situation is also causing considerably anxiety on account of the shortage and extraordinarily high

CANADIAN GOVERNMENT PURCHASING COMMISSION

The following gentlemen constitute the Commission appointed to make all purchases under the Dominion \$100,000,000 war appropriation:—George F. Galt, Winnipeg; Hormidas Laporte, Montreal; A. E. Kemp, Toronto. Thomas Hilliard is secretary, and the Commission headquarters are at Ottawa.

price. The steel mills as well as the furnaces are feeling the effects of the coke scarcity. Prices of domestic foundry iron are still withdrawn. Bessemer iron is now being quoted at \$55.95 in Pittsburgh, while several other grades have reached the \$50 mark.

Scrap

The scrap market is dull and featureless, with prices at the same level as last week. Heavy melting steel is the only material that is at all active, and higher prices are expected. With this exception the demand for most scrap metals is light, consumers apparently not showing much interest in the market at the present time.

Machine Tools

There is nothing of much importance to note with regard to machine tools. The market is gradually assuming a more normal condition, and the demand is generally for machinery for general purposes. The high prices of machine tools are having a tendency to restrict business. Unless the requirements are urgent, consumers are inclined to wait until prices are more favorable. In the States the market is very active, there being an unusually heavy demand for

large machine tools for shipbuilding and munitions purposes chiefly.

Supplies

The demand for a general line of machine shop supplies continues active at firm prices. Pure Manila rope has advanced 3½c, and is now quoted at 37c per pound. Differentials in certain classes of rope have been changed, which in some cases figures out as a slight net decline. Transmission rope and belt rope now carry a differential over base of 6c as compared with 8c formerly, which makes a net decline of ½c per pound. Drilling cables, however, have advanced ½c per pound by the changing of the differential over base size to 2c. White lead has advanced again, and is now quoted at \$19 per 100 lbs., in ton lots. Turpentine has declined, and now ranges in price from 62½c to 69c per Imperial gallon. Linseed oil is also lower, ranging from \$1.43 to \$1.46 for boiled oil; raw oil being 3c cheaper.

Metals

The metal markets continue firm, due principally to expectation of a large volume of business rather than to any great activity at the present time. The requirements of the American Government are not yet known, and there is still a feeling of uncertainty in the market as to what may develop. The local situation is unchanged, and the outlook generally continues favorable. Prices are firm and unchanged on the basis of last week's quotations.

Copper.—The market is quiet, but firmer, notwithstanding the comparatively small volume of business. Most of the leading producers are now out of the market for delivery before September. More interest, however, centres on later positions, and fourth quarter copper shows greater proportionate strength than the nearer positions. Prices continue nominal, lake and electrolytic being quoted at 38c and castings 37c per pound.

Tin.—The tin situation is unchanged and the market continues firm. A feeling exists in the trade that permits for shipping tin from England will in the near future be easier to obtain, which will tend to weaken prices. Tin is firm locally and quoted at 66c per pound.

Spelter.—The market is dull and demand light, although prices are holding firm at 12c per pound.

Lead.—The market is slightly easier, but quotations are unchanged. Producers continue to keep out, and are offering no new lead for sale. Increased production during the rest of this month, and in July is expected, and in this event there may be more lead for sale, which will naturally tend towards an easier market and lower prices. Local quotation unchanged at 11½c per pound.

Antimony.—The demand is light and the lack of buying interest has had its effect in an easier market, especially for prompt delivery. Demand is principally confined to the more distant positions, which are proportionately firmer than the nearby. Local price 26c per pound.

Aluminum.—There is no change in the situation. The supply is still light and prices firm at 68c per pound.

Sydney, June 15.—Meetings have been held during the week beginning June 11 between the representatives of the Provincial Workmen's Association and the United Mine Workers of Nova Scotia. It is stated that a basis of amalgamation is likely to be reached, and that a fusion of the two labor unions may be expected shortly.

The Acadia Coal Co. has granted an increase to the day laborers employed at its collieries. All day rates under \$2.67 are increased 15 cents per day, plus an increase varying between 6 per cent. and 9 per cent., applied in addition to the 6 per cent. increase given in December last. Day laborers rated at above \$2.65 per day and miners are granted an increase of 9 per cent., also applicable in addition to the 6 per cent. previously given. This latest adjustment brings the minimum wage of the common laborer to \$2.37 per day.

Sydney has had a visit from Arthur A. Cole, the president of the Canadian Mining Institute, who is acting as field officer of the Advisory Council at Ottawa, who are undertaking an inventory which it is hoped will lead to a "mobilization" of the industrial and research facilities of the Dominion. Mr. Cole also conferred with the executive of the Nova Scotia Mining Society regarding the mooted affiliation of this society with the Canadian Mining Institute.

Coal Production

Coal production is being fairly well maintained, although some slight decline is noticeable with the finer weather. Farming operations and potato planting are in advance of any previous year in the life of the mining districts. The Dominion Coal Co. itself has planted sufficient land with potatoes to yield, under ordinary weather conditions, between 6,000 to 8,000 bushels. This is in addition to the individual plots of the miners, who are being assisted by the company in every possible way. The same may be said of the Sydney district and the steel employees.

The construction of two new blocks of coke ovens for the Dominion Iron & Steel Co. at Sydney is now well in progress, and a large number of men are employed on the work.

It is said that the areas of the Mabou & Gulf Coal Co., in Inverness County, with the equipment and railway, is likely to be acquired by a strong American concern, and that active mining operations may be resumed. The property has been idle ten or twelve years, following the flooding of a development slope.

The Scottish Hero, one of the Dominion Steel Corporation boats engaged in Transatlantic trade, has been torpedoed. This is the third vessel lost in this service. The Morwenna was torpedoed last year, and the Sheba was lost, but whether she was destroyed by mine or torpedo, or otherwise, is not known.

The Storstad was torpedoed earlier in the year. This vessel was under charter to the Steel Co., and was sunk while acting as a Belgian relief ship. The captain of the Scottish Hero was also captain of the Morwenna when she was sunk. The fate of the crew of the Hero is not yet known.

Pittsburgh, Pa., June 16.—Business in the steel market has come almost to a standstill, as the large Government requirements hang over the situation, but are not expressed in actual orders, so that producers do not know where they stand, and consumers realize that placing orders with the mills would not do any good, as the latter are in no position to give any inkling as to when they would be able to ship. Steel manufacturers returning from Washington say that matters are in apparent chaos there, plans being worked upon, but not reaching the stage at which definite orders can be given. Possibly the fact that the war budget bill of \$3,340,000,000 has been passed, and was signed by the President on June 15, will release some orders, but it is somewhat doubtful whether important orders have been held up on that account.

There is no basis on which anything like a close forecast can be made as to the amount of steel the Government will eventually require for its own use or for its Allies, but it is distinctly possible that the total may reach 40 or 50 per cent. of the country's output. It is true that the purchases for account of the Entente Allies will in considerable measure be a replacement or a continuance of the orders they have hitherto been placing, but when they reduced their buying some months ago the trade was assumed to be gone, and the mills have been filling up with other orders, so that the fresh buying will have the aspect of new business.

Indications are that the programme for building steel freighters by the Emergency Fleet Corporation, General Goethals, general manager, are working out even better than expected, and that it will be possible to provide a very large shipyard capacity for consuming steel in that manner. Eventually this shipbuilding will probably consume at least 3 per cent., and perhaps up to 5 per cent., of the total steel output, this being apart from steel used in building war craft. Then there is the plan, reported a week ago, for the Government to buy 100,000 freight cars. Probably all these cars, if secured, would be used on American roads, being leased for the duration of the war, and then sold to the roads at a suitable price. Purchases for Russia and France would probably be in addition. No announcement as to locomotives has been made, except that there is a committee on locomotives similar to that on cars. The cars and locomotives together might take 5 per cent. or more of the steel production. How this would disarrange regular commercial operations is shown by the fact that car shops have lately been refusing to quote at all on inquiries from South America, stating that they cannot possibly secure any steel

from the mills for such a purpose. In case the Government ordered the cars, the steel mills would simply be asked to furnish the steel, to the delay of other orders.

All the mills and their customers can do is to wait until the Government plans are brought to a head, and it is seen how much steel can be used. It is not a case of finding steel so much as it is a case of finding shop or shipyard capacity to work it up into the desired forms. Necessarily the mills as a rule simply take the attitude that they are out of the market, except for Government requirements. Some contract business is being placed, of course, but it is simply of routine character, the mills booking additional tonnages from regular customers, to be shipped whenever present contracts are worked out.

Steel

There are no defined market prices for finished steel products. There is no longer a regular market "for shipment at mill convenience," and prices for early deliveries, say, in three to six months, vary according to circumstances. These prices still show an advancing tendency. Black and blue annealed sheets are, say, half a cent. a pound higher, at 7.50c to 8.00c, while merchant bars are up about a $\frac{1}{4}$ c, to, say, 4.25c to 4.50c. Orders can hardly be placed at all except by regular customers. Shapes are still nominally 4.25c to 4.50c.

Exports

Iron and steel exports in April amounted to 521,176 gross tons, against 606,563 tons in March, 449,107 tons in February, 608,286 tons in January, and a monthly average of 509,000 in 1916. It is recalled that last March there was a large tonnage of steel at seaboard awaiting vessels, and it is quite likely that of late the actual shipments from mills and furnaces have been at a considerably smaller rate than would be suggested by the statistics of actual exports.

Pig Iron and Scrap Rise

Furnaces continue to mark up pig iron prices, there having been an average advance of about \$2 a ton in the past week. Prices are now squarely on the basis of \$55 for Bessemer and \$50 for basic, malleable and foundry, at valley furnaces, with \$53 paid on some small lots of foundry and malleable for early shipment. The furnaces are indifferent about selling, as they have disposed of a fair fraction of their output for the first half of next year, and have little left for this year. Their attitude is a natural one, seeing that up to date they have not, on the whole, profited one cent by the advance. The majority of them are still shipping \$18 iron, sold last August, and as they have had to pay fancy prices for spot coke to eke out their insufficient contract deliveries, they frequently show a loss on the month's business.

For about a week the Carnegie Steel Company paid \$40 for all the heavy melting steel offered, raising its bid in the past few days to \$42, while dealers are now talking \$45 or even higher.

INDUSTRIAL ^A_N^D CONSTRUCTION NEWS

Establishment or Enlargement of Factories, Mills, Power Plants, Etc.; Construction of Railways, Bridges, Etc.; Municipal Undertakings; Mining News

ENGINEERING

Hamilton, Ont.—The National Machinery Co., will build a plant here.

Ottawa, Ont.—The Ottawa Car Co., has let contracts for the erection of a repair shop to cost \$60,000.

Vancouver, B.C.—The Western Iron Works will build a boiler shop to cost about \$30,000. Hodgson & King have the contract.

Three Rivers, Que.—The Three Rivers Casting Co., will build a brick foundry at a cost of \$35,000 and will be in the market for foundry equipment, lathes, etc.

Montreal, Que.—N. M. Loney, engineer, of the American Can Co., Maisonneuve, is asking for prices on two 150 h.p., 150 lb. pressure return tube boilers. Head office 120 Broadway, New York.

Chatham, Ont.—The Gray-Dort Motor Co. have purchased the plant formerly owned by the Blonde Lumber Co. They will utilize the plant for the manufacture of auto bodies.

Fort William, Ont.—It is considered likely that the Canadian Car & Foundry Co. will build a large number of cars here in connection with the order which they recently received.

Port Arthur, Ont.—The foundations for the Port Arthur Pulp & Paper Co.'s mill are practically completed and construction well under way. Most of the contracts have been let.

Prince Rupert, B.C.—An effort is being made by the City Council and Board of Trade to find some means of utilizing the drydocks and shipbuilding plant which has been practically idle since its completion about 12 months ago.

Sarnia, Ont.—With a view to branching out more extensively into brass manufacturing after the war, when the munitions business will be abandoned, the Mueller Company is laying plans for adding an extension to its present plant for the manufacture of brass rods, tubes, etc.

St. John, N.B.—A meeting of the hospital committee from the municipal council was held on June 11 at the General Public Hospital. Dr. Thomas Walker presiding, to open tenders for the work of installing boilers and other equipment in the new power house. Considerable attention was given the matter, but no decision was reached.

Wileybury, Ont.—An effort is to be made to induce the Riordon Pulp and Paper Co. to erect the large plant which has been under consideration for some time, at this place. Mayor Wright visited Montreal recently and interviewed the president of the Riordon Company in regard to the selection of Wileybury as the most suitable site in the North Country for their plant.

Edmonton, Alta.—The Edmonton Cement Co., has been reorganized and the plant at Marlboro on the G.T.R. will be put in operation by August. The capacity of the mill will be increased to 2250 barrels of cement per day. Alexander Macdonald of Winnipeg is the new president and John A. MacDougall of Edmonton is managing director.

Halifax, N.S.—A branch factory is to be established at Halifax by the L'Air Liquid Society, the Canadian headquarters of which are at Montreal, where the company has a large factory. Negotiations for the purchase of a lot have been completed by Charles Royer, the general manager, who is in Halifax this week. The factory will be located in the vicinity of the Cotton Factory siding, and will be 100 x 50. The company will manufacture acetylene cutting and welding machines.

GENERAL

Hamilton, Ont.—The National Paper Goods Co., will build an addition to its factory to cost \$10,000.

Drummondville, Que.—It is understood that the Aetna Explosives Co., will shortly close down their plant here.

Dennison Road, B.C.—The Fir Tree Lumber Co., Fraser Valley, Dennison Road, B.C., will build an electrically operated sawmill to cost \$60,000.

Winnipeg, Man.—The Stewart Sheaf Loader Co., manufacturer of agricultural implements, etc., will build a new factory. J. S. Menzies is manager.

Toronto, Ont.—The Cowan Co., 72 Sterling road, has been granted a permit to erect a one-storey brick addition to their cocoa factory at a cost of \$3,000.

Regina, Sask.—On June 11, the Regina Storage and Forwarding Co.'s plant was destroyed by fire with virtually all the contents. The building and cold storage plant, valued at \$27,000, is a total loss. It was partly covered by insurance. The contents were valued in the neighborhood of \$150,000; insurance being held by individual owners. Defective wiring is believed to have been the cause.

MUNICIPAL

Iroquois Falls, Ont.—The Abitibi Power & Paper Co. will build a new steel tower transmission line for high voltage transmission.

Cobalt, Ont.—The Town Council have definitely decided to instal a telephone system as soon as the franchise of the Timiskaming Telephone Co. expires.

Montreal, Que.—A. Pion the contractor announced recently that he had made satisfactory arrangements enabling him to undertake the construction of the La Salle bridge over the aqueduct.

St. Mary's, Ont.—A by-law will be submitted to the ratepayers on the question of a sliding scale bonus of \$5,000 to the Thames Quarry Co. If the company uses sufficient electrical energy in one year to give a \$1,000 profit to the town, one-fifth of the profit is to be returned to the company until the \$5,000 is paid out.

Wellington, Ont.—A series of meetings are being held here, called by Reeve Clarke, relative to supplying this village with hydro power in the event of its being introduced shortly into Prince Edward County. It is suggested that the village take 75 horse-power at a given rate from the commission and sell the power to consumers.

Toronto, Ont.—According to Works Commissioner Harris the new Bloor street viaduct will not be opened for traffic until the middle of next summer. The Commissioner has informed the Board of Works that while the structural work may be completed before the end of the year, it would be inadvisable to lay a pavement on the bridge during the cold weather, Commissioner Harris said that he did not intend to lay the pavement until the structural work was completed.

Winnipeg, Man.—An inventory of the machinery and scrap metal that the city owns is being made with the object of selling it. Lists that have so far reached the Board of Control from department heads, indicate that a vast amount of material has accumulated during recent years. There are numerous engines, power street rollers, constructional equipment, dismantled bridges, and tons of scrap metals. It is expected that a considerable part of the machinery can be sold to western towns or to contractors. The total value is estimated at \$50,000.

TENDERS

Pointe Claire, Que.—Tenders will be received by J. B. Martin, secretary-treasurer, up to June 27, for water filtration plant and low lift pumps. Plans and specifications may be obtained from R. S. and W. S. Lea, 809 New Birks Bldg., Montreal.

Toronto, Ont.—Tenders are now being received by the owners and sub-tenders by the Sherwood Construction Co., Mail Building, for the erection of a \$125,000 reinforced concrete packing plant for the Swift Canadian Co., West Toronto.

Toronto, Ont.—Tenders, addressed to the secretary-treasurer of the Board of Education, will be received until June 28, for electrical work, etc., required for manual training and domestic science centres in Earl Grey Public School, Jones Avenue, also midsummer repairs—sundry trades. Specifications may be seen and all information obtained at the office

of the superintendent of buildings, Administration Building, 155 College Street.

Kingston, Ont.—Tenders will be received until July 16, for the reconstruction of part of the cribwork wharves at the entrance to the Dry Dock, at Kingston, Ont. Plans and forms of contract can be seen and specification and forms of tender obtained at the Department of Public Works, Ottawa, the offices of the District Engineer, Equity Building, Toronto, Ont., and on application to the Postmaster, at Kingston, Ont.

Montreal, Que.—Tenders for the supply and installation of underground cables, street pedestals, fire alarm boxes, cable boxes and accessories for St. Lawrence Boulevard from Craig to Sherbrooke and intersecting streets, addressed to the Board of Commissioners, will be received until June 26. The specification, forms of tender and all required information may be obtained at the office of the Superintendent of Purchases and Sales, City Hall.

CONTRACTS

St. Lambert, Que.—The Town Council has awarded the contract for a centrifugal pump to Laurie & Lamb of Montreal.

Welland, Ont.—The Electro-Metals Co. have placed an order with the Storey Pump & Equipment Co., for one 8-inch "Morris" turbine pump having a daily capacity of two million gallons.

Ottawa, Ont.—A contract has been awarded by the Dominion Government to the Canadian Car & Foundry Co. for 3,000 freight cars for the Government Railway System.

Iroquois Falls, Ont.—The Abitibi Power & Paper Co. have awarded a contract to the Bawden Pump Co., Toronto, for four centrifugal pumps, each of one million gallons daily capacity.

Port Arthur, Ont.—The Port Arthur Pulp & Paper Co. have awarded a contract to the Storey Pump & Equipment Co., Toronto, for two 10 x 6 x 12-inch "Deane" duplex, end packed plunger boiler feed pumps.

BUILDING

Hamilton, Ont.—A permit has been issued to the Bell Telephone Co., for a new exchange building to be erected on Garfield avenue, at a cost of \$46,000.

Toronto, Ont.—The Canadian Dyers' Association, Liberty Street, has been granted a permit to add a one-storey brick structure to the factory at a cost of \$8,000.

TRADE GOSSIP

Montreal, Que.—The C.P.R. has 2,000 cars under construction at the present time. They will be distributed to all parts of the system. In addition, twenty-five new Decapod locomotives are being built for use on the mountain division.

The Bawden Pump Co., Toronto, have been awarded a contract by Fraser's, Ltd., Edmunston, N.B., for 14 centrifugal pumps of from one to four million Imperial gallons daily capacity, and also a

compound boiler feed pump. This equipment is for a new pulp and paper mill.

The Storey Pump & Equipment Co., Toronto, have recently been awarded the following contracts: Two 4 in. double suction Morris centrifugal pumps for the Swift Canadian Co., Toronto; two 4-stage Morris turbine pumps for Gravenhurst, Ont.; one 4 in., 4-stage Morris turbine pump for the Canadian Copper Co., Sudbury, Ont.

Loans \$10,000,000 to Munitions Board.—The C.P.R. has made a loan of \$10,000,000 to the Imperial Munitions Board, so the company stated recently. The last balance sheet of the C.P.R. of the date of December 31, 1916, showed \$57,076,018 in cash on hand, and it is from this the company is able to make the loan.

Newfoundland Pulp May Go to the U. S.—The Newfoundland Legislature, now in session, is expected to enact a law permitting export to the United States of a considerable quantity of pulpwood, cut in the colony since the outbreak of the war. The wood was intended for shipment to England and France, but because of the shortage of ships its transfer to those countries has become impossible.

Shipments of Pulp.—The increased facilities for shipping brought about through the opening of the St. Lawrence have had a beneficial effect on many Canadian industries. Recently the Riordon Pulp and Paper Company have sent a shipload of sulphite pulp to Spain, while another is to be shipped shortly to Calcutta. A quantity of pulp has been sent to Italy, but the risks attendant thereon are so great as to make trading in that direction undesirable.

Vancouver, B.C.—The Rainy River Pulp and Paper Co., whose mill is at Port Mellon, Howe Sound, has commenced the production of kraft pulp. The plant has been changed from a soda paper mill to a kraft pulp and paper plant, and that accomplished in record time. The plant was purchased by the Rainy River Pulp and Paper Co. from the previous owners on February 1, 1917. The plant is thoroughly organized and equipped for the production of kraft pulp as well as the finished paper, for which there is an unlimited demand.

Safety Equipment On Railway Cars.—An extension of time for the equipping of their cars with certain safety devices regarded as necessary for the safety of railway employes, and ordered by the Dominion Railway Board in July of 1914 has been secured by the C.P.R. and G.T.R., when their representatives appeared before the Board, and pointed out that owing to the lack of labor it has been impossible for them to equip their cars according to schedule. The period of extension will not be fixed until the return of Chief Commissioner Drayton from the West.

Start Shipping Rails to France.—Rails for the battlefield in France and Flanders are being procured from the line of the Grand Trunk Pacific through the Yellowhead Pass from Imrie to Resplendent,

a distance of 207 miles. By the use of rails from the Canadian Northern line between the two points a composite line will be laid which will serve the industries of the district and put the settlers to the minimum amount of inconvenience. The composite line will be constructed on 128 miles of C.N.R. roadbed and 77 miles of G.T.P. The first shipment of rails will be in transit to Three Rivers this week and the balance will be on the way by the end of July.

Plan New Metal Committee.—The Department of Commerce, Washington, D. C., has authorized the following statement: As a result of a meeting attended by the representatives of the tin industry, held at the office of the Bureau of Foreign and Domestic Commerce, the American Iron and Steel Institute will be asked to call a meeting to form some sort of an organization to be responsible to the bureau for the equitable allotment of pig tin in this country. It is understood by the bureau that the British Government has signified a willingness to turn over this important duty to the Department of Commerce of the United States.

Manufacturers Miss Opportunities in France.—Philippe Roy, the Canadian Commissioner-General at Paris, says that the reason why Canadian manufacturers have not been able in the past to do business more extensively in France is that they have been unable to quote prices on goods delivered at French ports. The French business man, he says, wants to pay for what he buys in France and in francs. Consequently the question of transportation and exchange must be solved by the exporter. It has been because the Hudson Bay Company was able to give satisfaction to the French Government on these two points that it has been enabled to place important orders in Canada.

Abundant Coal Promised West.—The important announcement was made on June 13 by Dr. Ruttan, of the Government's Research Council, to the Manufacturers' Association at Winnipeg, that Western Canada will have abundance of coal within a very short time at a price about two-thirds the price of anthracite. This will be secured by a process for the treatment of lignite coal lying in such vast quantities in Western Canada, and, according to figures given by Dr. Ruttan, there can be turned out from Winnipeg from 100,000 to 200,000 tons daily. The whole scheme for this undertaking is complete, and has been recommended to the Government, the preliminary cost of equipment being given at \$400,000.

Cars Ordered for Government Roads.—Contracts for the construction of 5,000 cars for the Canadian Government Railway System have been let by the Government and orders for another 2,000 will be placed in the near future. Contracts were made some weeks ago with the Eastern Car Co. and the Canadian Car & Foundry Co., under which each concern is to build 1,000 cars. Last Thursday a second contract for 3,000 additional cars was awarded the Canadian Car & Foundry Co. At the same time 50 loco-

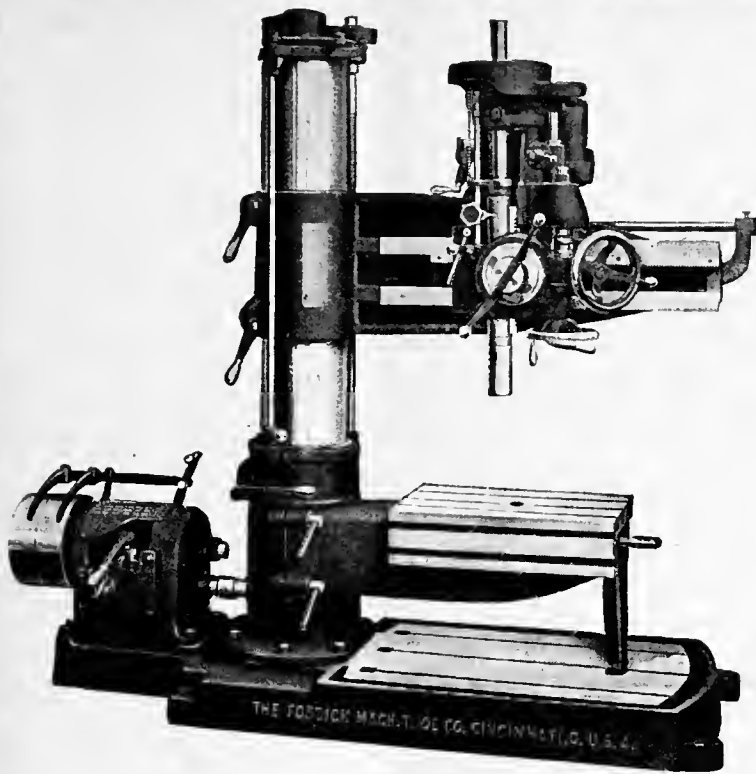

IN STOCK
3½-Foot FOSDICK

Heavy Duty Radial Drill
Single Pulley, Speed Box Drive
New

ALSO TWO
6-Foot LONDON

Plain Radials
in fine condition.

**WRITE FOR PRICES
AND PARTICULARS**

The A. R. Williams Machinery Company, Limited

ST. JOHN, N.B.
WINNIPEG, VANCOUVER

"If It's Machinery, Write Williams"

64 Front Street West,
TORONTO



There Is An Opening
In the Geometric Circle
For You

The Geometric Circle increases constantly with each new demand. It is kept open for you.

Come In

We specialize on Screw-cutting Tools. Our Self-opening Die Heads and Collapsing Taps are in use on all makes of Screw Machines and Turret Lathes. Whether your work calls for an external or internal screw thread, of whatever diameter, pitch, length or form, take the proposition up with us, and you will not regret it. Our experts will know just what features will best adapt a tool to your work.

THE GEOMETRIC TOOL COMPANY

NEW HAVEN, CONNECTICUT, U.S.A.

Canadian Agents:--WILLIAMS & WILSON, LTD., MONTREAL; THE A. R. WILLIAMS MACHINERY CO., LTD., TORONTO, WINNIPEG AND ST. JOHN, N. B.

If any advertisement interests you, tear it out now and place with letters to be answered.

OVENS
 Enameling and Varnishing Ovens heated
 by Gas, Electricity, Steam or Coal.
 Write for Booklet.
Brantford Oven & Rack Co., Ltd.
 Brantford, Canada.

**Hamilton Anti-Friction
 BABBITT**
 A Dependable Metal for
 Speed and Pressure.
Geo. E. Jobborn, Hamilton, Ont.

**"HAWK" D
 CHROME
 VANADIUM
 STEEL**



Will
 Give You
 Exceptional

**Shell Forging
 Production**

WITHOUT AN EQUAL FOR
 BOTH FIRST AND
 SECOND OPERATION
 PUNCHES.

Comes to you heat-treated
 and ready for use.

It does not stick to the
 work.

There are many cases where
 each punch has turned out
 over 2,000 shells.

It means more shells, per
 machine per day.

**STEEL OF EVERY
 DESCRIPTION.**

**Hawkrige Brothers
 Company**

303 Congress St., BOSTON, MASS.
 U. S. A.

motives for the Government Railway System are being constructed at Kingston, and a like number in Montreal. The Intercolonial and Transcontinental will thus, when the orders are all completed, have 7,000 more cars and 100 more locomotives to meet traffic requirements.

High Water Level for Lake of Woods.
 —Measures for maintaining the Lake of the Woods with a level which will, in their opinion, secure to the inhabitants of both sides of the international boundary the most advantageous use of the waters of that lake, flowing into and out of the lake, and of their shores and harbors, are recommended in a report of the International Joint Commission which has been made public simultaneously at Ottawa and Washington. The six members of the commission have recognized water power as the dominant interest of the region, and have provided for the utilization of the Lake of the Woods and the upper lakes as immense storage reservoirs for the benefit of that interest. They have considered the interests of navigation, the fisheries, agriculture, lumbering, manufacturing, mining, and tourist travel, and have recommended that the Lake of the Woods be maintained at 1061.25 sea level datum.

Canadian Electric Railway Association.
 —At the recent annual meeting of the Association held in the Windsor Hotel, Montreal, the following officers were elected for the ensuing year:—President, C. L. Wilson, assistant general manager, Toronto and York Radial Railway, Toronto; Hon. Sec-Treas., Acton Burrows, Toronto. The Executive Committee is as follows: J. D. Fraser, director and secretary-treasurer of the Ottawa Electric Railway, Ottawa; A. Gaboury, superintendent Montreal Tramways, Montreal; E. P. Coleman, Hamilton; G. Gordon Gale, vice-president and manager, Hull Electric Railway, Hull; J. S. Mackenzie, purchasing agent, Winnipeg Electric Railway, Winnipeg; H. G. Matthews, general manager, Quebec Railway, Light, Heat & Power Co., Quebec; E. L. Milliken, manager Cape Breton Electric Railway, Sydney, C.B., and Aubrey A. Burrows, Toronto.

Canadian Trade Bounties.—According to the latest report of the Department of Trade and Commerce at Ottawa, trade bounties amounting to \$21,669,965 are paid out annually. The following amounts were paid out in one year, according to the Government's statistician:

	Amount, Tons.	Bounty, Dollars.
Pig Iron.....	5,431,547	7,097,041
Puddled Iron Bars	42,812	113,674
Steel	4,448,780	6,706,990
Manufactures of Steel	499,312	2,868,122
Lead (pounds). 1,187,083,350		1,979,164
Manila Fibre (pounds) ...	108,048,641	367,962
Crude Petroleum (gals.)	169,134,123	2,537,012

Total bounties.....\$21,669,965

INCORPORATIONS

The United Brush Co. of Canada, Ltd., has been incorporated at Ottawa with a capital of \$50,000 to manufacture of brushes of all kinds at Hamilton, Ont. The incorporators are Morris Fletcher, Harry Nex and Alex. W. Brown all of Hamilton.

Holden-Morgan Thread Miller, Ltd., have been incorporated at Toronto with a capital of \$600,000 to carry on the business of mechanical engineers and manufacturers at Toronto. The provisional directors are W. A. Y. Case, J. B. Taylor and W. M. Smith all of Toronto.

The Pressed Metals Co., of Canada, Ltd., has been incorporated at Ottawa, with a capital of \$2,000,000 to manufacture and deal in iron, steel, brass and all other metals. The head office is at Toronto and the incorporators are Charles E. Calvert, H. L. Nussbaum and W. T. Fraser all of Toronto.

The Canada Iron Products Co., have been incorporated at Ottawa with a capital of \$1,000,000 to manufacture and deal in iron, steel, coke, colors, paints and chemical preparations of every description. The head office is at Montreal and the incorporators are R. E. Allan, J. P. Charbonneau and William Taylor all of Montreal.

RAILWAYS—BRIDGES

Ridgetown, Ont.—The M.C.R. contemplate erecting a water tank here.

Edmonton, Alta.—In the Lacombe district great interest is being taken in the building of the Lacombe & Blindman Valley electric railway, which is now being gradually pushed forward to completion. Steel for the line as far as the outlet has already been bought and several carloads of rails and angle bars have already arrived at Lacombe, and every few days more carloads are being shipped in. The laying of the rails has now begun.

REFRIGERATION

Windsor, Ont.—D. D. Drulard has had his meat market equipped with a 3-ton refrigerating plant, supplied by the Frick Co., Waynesboro, Pa.

Montreal, Que.—The International Manufacturing Co. has installed a 120-ton refrigerating plant, supplied by the Frick Co., Waynesboro, Pa., for cooling purposes in their munitions factory.

St. Johns, N.F.—The Reid Newfoundland Co. is erecting a cold storage and fish freezing plant near the railway station. The main building to be of concrete 200 x 99 feet, three storeys high. The cold stores are to have capacity for about 10,000,000 pounds of fish. It is planned, in addition, to build six branch plants at export stations, the first of these to be erected at Port-aux-Basques, which is to have cold storage capacity for 2,000,000 pounds of fish. The other branch houses, it is stated, will be probably at Bonavista, Lewisport, Bay-de-Verde, Placentia and Trespassey, and will be of about 500,000 pounds capacity each.

PERSONAL

W. P. Hinton, traffic manager of the G.T.R., will, it is understood, be appointed general manager.

George Beardmore, Toronto, and W. G. Ross, of Montreal, president of Asbestos Corporation of Canada, have been elected to the board of directors of the Canadian General Electric Co.

S. R. Parsons president of the British-American Oil Co., Toronto, was elected president of the Canadian Manufacturers Association at the annual meeting in Winnipeg last week.

John Wilson, of the engineering staff of the Structural Steel Co., Montreal, has joined the contracting-engineers' staff of the Dominion Bridge Co., at Lachine, P.Q.

T. A. Russell of the Russell Motor Co. and Holt Gurney of the Gurney Stove Co., Toronto, have been appointed by the Imperial Munitions Board to purchase machinery for the wooden vessels under construction in Canada.

Edward Holgate, who has been chief draftsman with the Structural Steel Co. of Montreal for the past seven years, has accepted a position as chief engineer with MacKinnon, Holmes & Co., Ltd., of Sherbrooke, Que.

Reginald H. Balfour, has been appointed sales manager of the Eugene F. Phillips Electrical Works, Ltd., Montreal. Mr. Balfour is a graduate of McGill University. He was formerly engineer for the Montreal Electrical Commission.

H. W. Hutchinson, of Winnipeg, vice-president of the John Dere Plow Co., director of the Dominion Bank, and closely identified with many other large institutions, has been elected to the directorate of the Sawyer-Massey Co., of Hamilton, Ont.

R. J. Younge, general manager of the Export Association of Canada, Montreal, who went to South Africa last March in the interests of the association and its trade relations with that country, is now at Johannesburg. He plans to sail on his return to Canada on July 6.

C. B. Gordon, president of the Dominion Textile Co. of Montreal, and a member of the Imperial Munitions Board in Canada since it was organized, will, it is understood, become purchasing agent of the British Government in the United States, so far as munitions are concerned. Mr. Gordon is at present in England.

Henry Hague Vaughan, who was recently appointed to a high executive position with the Dominion Bridge Co., has now been made general manager of the company. Mr. Duggan, the former general manager, becomes chairman of the Board of Directors, and also retains the title of chief engineer of the company.

John William Seens, general manager of the Structural Steel Co., Montreal, has joined the engineering staff of the Canadian Bridge Co., of Walkerville, Ont., the plant of the Structural Steel Co. having been taken over by the Montreal Locomotive Works.

W. Sanford Evans, chairman of the Georgian Bay Canal Commission, has been requested to accept the position of

**PATENT
ATTORNEYS**

BABCOCK & SONS
ESTAB. 1877
PATENTS-TRADE MARK-DESIGNS
IN ALL COUNTRIES

Book "Patent Protection"—free. Master of Patent Laws, Formerly Patent Office Examiner.
99 St. James St., - Montreal, Que.
Branches: Ottawa, Washington.

RESEARCH BUREAU

REPORTS BY EXPERTS ON SCIENTIFIC, TECHNICAL AND INDUSTRIAL DEVELOPMENT.
SPECIAL RESEARCHES ARRANGED.

PATENTS, TRADE MARKS, ETC.

HANBURY A. BUDDEN CABLE ADDRESS
712 DRUMMOND BLDG., MONTREAL "BREVET"

PATENTS

Fetherstonhaugh & Co.,
Patent Solicitors, Head Office,
Royal Bank Bldg., Toronto,
Ottawa Office, 5 Elgin St.
Send for our Plain Practical
Pointers. Copy of National
Progress, in which our patents
are advertised, mailed free.

**PATENTS
PROMPTLY SECURED**

In all countries. Ask for our Investor's Adviser,
which will be sent free.

MARION & MARION 364 University St.
Merchants Bank Building, corner
St. Catherine St., MONTREAL, Phone Up. 6474
and Washington, D.C., U.S.A.

**MacKinnon,
Holmes & Co.**
LIMITED
Sherbrooke,
Quebec

Builders of
**Coal Bunkers,
Oil Tanks, Water
Tanks and Receivers**

We specialize in Bridges, Buildings, Towers,
Tanks, Penstocks, Roof Trusses, Columns,
Smoke Flues and Stacks, Coal Bins,
Ore Bins, Buckets, Refuse Burners,
Stills, Air Receivers, etc.

Write for Prices



**"Barnes-made"
SPRINGS**

are the result of over sixty years' experience in spring making, combined with unsurpassed equipment and the workmanship of men who have been with us, ten, twenty and in some cases thirty years.

Write for booklet No. 7-T.

Established 1857.
THE WALLACE BARNES COMPANY
218 South St., Bristol, Ct., U.S.A.
Manfrs of "Barnes-made" Products
Springs, Screw Machine Products, Cold Rolled Steel and Wire

MORTON MANUFACTURING CO.

PORTABLE PLANERS
DRAW CUT SHAPERS
SPECIAL DRAW CUT R R SHAPERS
FINISHED MACHINE KEYS
STATIONARY & PORTABLE KEY WAY CUTTERS
SPECIAL LOCOMOTIVE CYLINDER PLANERS

OFFICE - WORKS: MUSKEGON HEIGHTS U.S.A.

ON PAGE 70

You'll find a host
of Opportunities.

TURN TO IT!

**METAL
STAMPINGS**

We are manufacturers of stamped parts for other manufacturers.

We do any kind of sheet metal stamping that you require. Our improved presses and plating plant enable us to produce the finest quality of work in a surprisingly short time.

We can finish steel stamping in Nickel Brass or Copper.

Send us a sample order.

W. H. BANFIELD & SONS
372 Pape Avenue, Toronto, Can.

"PURO - FY"

(MADE IN CANADA)

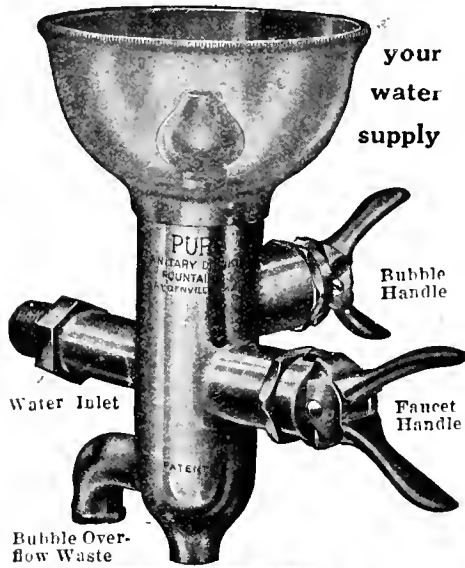

THE American Museum of Safety conferred a Gold Medal Award upon the Puro Sanitary Drinking Fountain at the First International Exposition of Safety and Sanitation. The Puro Sanitary Drinking Fountain won because it deserved to win—Puro had merits that made it stand head and shoulders above any other drinking apparatus.

Safe Simple
SANITARY Economical
Quickly Attached

These are the qualities that forced the leading safety and sanitary engineers to pick Puro in preference to all others. No device can be as efficient that does not contain all these qualifications; and Puro was not tied for first place; Puro was first. Don't be satisfied with half-way goodness, or makeshift drinking arrangements for your employees.

If the men in your factory must drink, give them a clean drink. Puro is clean—it does not rust or corrode. Puro is economical. It allows just the proper amount of cool, clean, fresh water to come through the bubbler. No spurtling, no overflowing, no loss. Puro regulates itself. You can attach it in five minutes. Tell us how many men in your factory and your water pressure in pounds—We'll tell you just what it will cost to "PURO-FY" YOUR WATER SUPPLY.

PURO SANITARY DRINKING FOUNTAIN

TRADE MARK

147 University Ave. TORONTO, ONT.

food controller for Canada during the war. The Order-in-Council defining the duties and powers of controller has been submitted to Mr. Evans, who will make any recommendations he considers necessary to ensure success to this proposal to regulate prices and distribution of food supplies.

D. W. Fraser, who for a number of years has been works manager of the Montreal Locomotive Works, has been promoted to the position of general manager and will have charge of the city office as well as that of the plant. His present activities will be divided between the plant and the head office, but with the passing of Government work and a return to the construction of locomotives, Mr. Fraser will be permanently located at the city office.

James Walter Lyon, president of the Guelph Radial Railway, is also president of the Guelph Junction Railway, vice-president of the Dominion Lumber Mills, Ltd., director of Preston Car and Coach Co., director of Sterling Rubber Co., and president of the Guelph Realty Co. Mr. Lyon was born in the United States and came to Canada in 1872. He is president of the Hydro Radial Association of Canada, which plans a system of railway lines throughout Ontario.

R. H. Parks has been appointed operating manager of the Canadian Car & Foundry Co., Montreal. Mr. Parks who will have charge of the operation of all the car plants has been identified with the car building industry for a great many years, and came to Canada from the Bettendorf Car Co. of Davenport, Ia. Coincident with this appointment, W. S. Atwood has been appointed assistant to the vice-president and managing director.

Donald Grant, builder of many railroads in the northwest, died at his home on June 13, at Faribault, Min., after a short illness. Mr. Grant was born in Glengarry, Canada, December 10, 1837. He went to Minnesota in 1863, entering into the railroad construction work. He assisted in building sections of the Chicago, Milwaukee and St. Paul, the Northern Pacific, the Great Northern, the Minneapolis and St. Louis, the Canadian Pacific and many smaller lines in the northwest.

Charles A. Magrath, who has been appointed fuel controller for Canada, is chairman of the International Joint Commission on Waterways. Mr. Magrath was born in North Augusta, Ont., fifty-seven years ago. In 1878 he went to the Canadian West and engaged in irrigation and other development work in Southern Alberta. Later he received an appointment as a member of the International Joint Commission, on which he has done excellent work. He was chairman of the temporary Commission erected in 1913 by Ontario to investigate and report on a comprehensive system of highways for that province. He will have complete power over the fuel supplies of the Dominion, their distribution and prices at the various points throughout the country. The purpose of the appointment is

to insure for the people a domestic supply during the coming winter.

Lawford Grant has been appointed manager director and treasurer of the Eugene F. Phillips Electrical Works, Ltd., Montreal. Mr. Grant came to Canada in 1907 as president and managing director of the Canadian British Insulated Co., Ltd. In 1913 he accepted a position as assistant manager of the Phillips Co., and now succeeds Geo. H. Olney, who was head of that firm for eighteen years, Mr. Olney having recently retired owing to ill-health. Mr. Grant is a civil and electrical engineer, and was formerly engineer for the British Insulated and Helsby Cables, Ltd., of England. Among the many undertakings which he carried out for the latter company was the electrification of the Government dock yard and naval base at Malta. The Phillips plant is, in size, among the first half-dozen of the insulated wire and cable works on this continent.

MARINE

Vancouver, B.C.—The Foundation Co. has been awarded contracts to build five wooden steamships for the British Government through the Imperial Munitions Board. The ground has been broken on the Songhees Reserve site, and work will be rushed to get the plant ready.

North Vancouver, B.C.—It is reported here that a deal has been completed for disposal of a portion of the Wallace shipyard interests. No authoritative statement regarding the matter is obtainable but it is reported on good authority that the western Wallace yard, that used in connection with the construction of wooden ships, is to be transferred to the Foundation Co., of Montreal.

Victoria, B.C.—The shipbuilding plant operated by the Cameron Genoa Mills Shipbuilders, Ltd., where the auxiliary schooners are now in various stages of construction, is to be enlarged for the purpose of making an immediate start on the four wooden steamers which have been awarded the concern by the Imperial Munitions Board. A new building ways is being laid down on the ground now under lease to the company.

Pier and Warehouse Collapse.—A section 150 feet long of the city pier No. 5 at West St. John collapsed at noon on June 13, with an equal stretch of warehouse and part of a grain conveyer. Three men had been in the warehouse office, but left only ten minutes before the collapse occurred. Forty men had been working in the warehouse. Too much weighty goods in the warehouse is given as the cause. Some six thousand cases of heavy goods for export were lost.

Vancouver, B.C.—Within the next three months it is expected that the first keel of the six new vessels that are to be built in Vancouver for the Imperial Munitions Board will be laid by the new concern known as the Western Canada Shipyards, Ltd. The amalgamation of three well-known companies has resulted in the formation of this concern, these companies being Grant, Smith & McDon-

THE IRON WORKS LIMITED

Successors to

Owen Sound Iron Works
Owen Sound, Ont.
Engineers
Boiler-makers
Founders
Machinists

Tank Work
Smoke Stacks,
Grey Iron and
Brass Castings,
Special
Machinery
Made to
Order

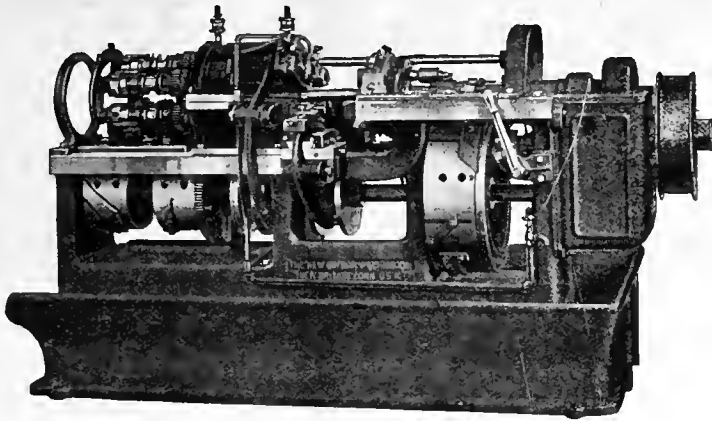

Screw Machine Queries:

IS ACCESSIBILITY A FEATURE?

IN THE CONSTRUCTION of many machine tools, access to parts requiring frequent change or adjustment often fails to receive sufficient attention.

The importance attached to this feature by the designers of the "New Britain" Six-Spindle Automatic is indicated by the many provisions for greatest convenience and economy of time in setting up and operating the machine.

A loose cover in cylinder housing permits of instant access to spindle bearing adjusting nuts.

The design of the spindle bearings—straight inside and taper outside—enables the slightest wear to be taken up without disturbance of the original alignment of spindles and tools.

Should it become necessary for any reason to remove a spindle, it may be accomplished without the removal of spindle cylinder. If, however, it is desired to take out the latter, all that is necessary is to remove the upper half of cylinder housing and withdraw drive shaft.

In effecting variations of spindle speed or feed, the "New Britain" design is exceptionally simple and convenient—the necessary gear changes being made without removal of driving pulley.

We will gladly submit production estimates for doing your work "The New Britain Way." Send us blueprints.

The New Britain Machine Company

—Automatic Screw and Chucking Machines—
New Britain, Conn., U.S.A.

STEEL STOCKS FOR EXAMPLE

Nearly every class of securities falls into some definite class, such as Steel, Milling, Transportation, Textiles, Pulp and Paper, Light and Power.

All stocks in these various classes are affected in the matter of their current market price by certain conditions, ever changing.

Hence it is of first importance to every man with investments or about to make investments to keep himself well informed, regularly, about the class or classes of securities in which he is interested.

He can do this by reading each week THE FINANCIAL POST OF CANADA.

The news and opinion concerning each of these classes of securities are provided fully each week, by writers in daily touch with their respective fields by the one man, in each case best qualified to deal with the class of security covered by him.

You can get well informed news and opinion at small cost from the POST each week and much else of value and interest.

Issued every Saturday, \$3 per year.

Write to the Publishers for sample copy.

The Financial Post of Canada, 143-153 University Ave., Toronto

nell, the Northern Construction Co., and Armstrong & Morrison. Operations have already commenced for the laying out of the site of the shipyard, on the location of the old Royal City Mills on the north side of False Creek, a lengthy lease having been obtained by the board on behalf of the company. Thus the initial measures have been taken that may mean the establishment on a permanent basis of one of the largest shipbuilding plants in the Dominion. A. R. Mann, of the Northern Construction Co., is president and managing director of the concern.

Vancouver, B.C.—R. P. Butchart and Capt. Troup representing the Imperial Munitions Board have given assurance that all the auxiliary machinery for the vessels will be built and procured here. This includes hoisting equipment and gear, and all of the hundred and one items of metal outfitting other than the engines themselves. The detailed plans for the engines are not all available so far and final decision regarding them will not be made until some further information has been received, from Ottawa. But it was represented that from twelve to fifteen engines can be built in the present British Columbia shops, including those in Vancouver, North Vancouver, Victoria, New Westminster and Prince Rupert.

CATALOGUES

Stow Grinders.—The Stow Mfg. Co., Binghamton, N.Y., have issued a bulletin featuring their line of internal grinders and flexible shaft equipments for munitions. The bulletin also illustrates Stow portable tools for various purposes.

Service Bureau Bulletin, issued by the National Founders' Association, Chicago, Ill. Bulletin No. 6 deals with various types of hand squeezers, with pattern and flask equipment, etc., particularly as to the attainment of satisfactory results and saving of time. The bulletin is fully illustrated.

Lathes.—Loose-leaf binder, containing a number of leaflets dealing with an interesting line of lathes manufactured by the Whitecomb-Blaisdell Machine Tool Co., Worcester, Mass. The various sizes of lathes are illustrated, together with a specification and principal dimensions covering each. The concluding pages of the catalogue deal with the reversible geared head lathes, with illustrations and specifications.

Planers.—The Whitecomb-Blaisdell Machine Tool Co., Worcester, Mass., have issued a catalogue illustrating and describing a line of planers which they manufacture. The catalogue contains a general description of the Whitecomb-Blaisdell second-belt drive planers, and deals with the advantages derived by the use of this type of drive. The principal features embodied in the design of these planers are illustrated and described at length, while the various sizes are also illustrated and accompanied by a specification giving the principal dimensions. This is a very attractive catalogue, and the illustrations are unusually good.

CLASSIFIED ADVERTISING

Rates (payable in advance): Two cents per word first insertion; one cent per word subsequent insertions. Count five words when box number is required. Each figure counts as one word. Minimum order \$1.00. Display rates on application.

SECTION

FOR SALE

FOR SALE — 1 HOLDEN-MORGAN BASE milling machine, 3-inch shell, Manitoba Bridge & Iron Works, Winnipeg.

FOR SALE — ONE LEWIS TYPE ENGINE built by Watrous Engine Works, 240 H.P., flywheel 73" x 18", automatic governor, a bargain. One steam pump, 4½" x 2¾" x 4". Write Box 217, Moncton, N.B. c24m

RADIAL DRILL, 4" CINCINNATI BICKFORD with single pulley drive and speed box, for sale or exchange for 6" Radial Drill; also Mitts & Merrill Keyseater, 12" stroke to cut 2" wide keyways. Boving Hydraulic & Engineering Co., Ltd., Lindsay, Ont. c26m

TWO NEW BOILERS, 66" x 16", FOR SALE, immediate shipment. One smoke stack, 54" x 50", also one C.G.E. generator, 62.5 K.V.A. with exciter and switchboard. Box 312, Canadian Machinery. (c24m)

ONE LATHE 16" x 4½" BACK-GEARED — Built by P. P. Silk Machine & Tool Co., Cincinnati, Ohio. One lathe 18" x 3", back-geared. Built by the Bradford Mill Co., Cincinnati, Ohio. Four Murehey collapsible dies. Capacity 1½" to 2½". Box 272, Canadian Machinery. ctmf

FOR SALE — TWO 15 x 6 REED PRENTICE Automatic Lathes. One Bertram Gap Lathe, 48 x 10. Four No. 10 Heavy Duty Baker Drills. One No. 2D Colburne Drill. One Heavy Duty Reliance Machine Co. Turret Lathe for inside boring of 6" shells. Canadian Blower & Forge Co., Kitchener, Ont. c24m

WE HAVE ON HAND AT OUR WELAND Works, for disposal, the following new machinery: — One (1) 18" x 15 ft. Accumulator; one (1) Aldrich Triplex Hydraulic Pump, 180 gals. capacity; two (2) 350-ton B. and B. Presses. All offers will be carefully considered. Canadian Car & Foundry Co., Ltd., Transportation Building, Montreal.

1 — ROBB HORIZONTAL STEAM ENGINE, 10 x 12, 35 h.p. Just overhauled by makers. Price \$300.00. **1** — Heavy Duty Rockford Drill. Suitable for shells or heavy work. Weight of drill 3,600 lbs. Good as new. Write for specification. **1** — Jones & Lamson 2 x 24 Turret Lathe, 2¼" hole in spindle, 16" swing, cone drive, collet chucks for bars up to 2" diameter. Or lathe can be fitted with standard universal chuck. Flat turret 16" diameter. Good condition. Price \$400.00. **1** — Warner & Swasey Turret Lathe. Round turret, diameter 8", hand cross feed for turret. Swing 11". Fairly good condition. Price \$200.00. **1** — Bertram 2-spindle Thread Miller. Made by makers for threading 18-pr. shells. Now used for threading sockets. Good condition. Steel Furnishing Co., Ltd., New Glasgow, Nova Scotia. c2m

SPECIAL MACHINERY

H. C. THOMAS, GENERAL MACHINE SHOP, tools, jigs and machine repairs. 301 King St. W., Toronto. Telephone Adelaide 3836. cfm

MANUFACTURERS — WE CAN UNDERTAKE work to any specification — munition production equipment or otherwise. Write W. H. Sumbling Machinery Co., 7 St. Mary St., Toronto.

S. VESSOT & CO., GENERAL MACHINE SHOP and Grey Iron Foundry. We can undertake at present time light machining and grey iron castings, at reasonable prices. Address Joliette, Que. c1m

BUSINESS CHANCES

SHELL PLANT FOR SALE — COMPLETE plant — installed since 1914, for the machining and assembling of 4.5 inch H.E. shells, situated at Dartmouth, Nova Scotia, on line of Intercolonial Railway, with siding running into the works. Will sell the equipment outright, with privilege of renting the building in event of the purchaser engaging in the same business. Starr Manufacturing Co., Limited, Dartmouth, Nova Scotia, Canada. c26m

FOR SALE — A MEDIUM-SIZED TWO-STOREY brick factory situated in the best small city in Ontario. Buildings in good condition, suitable for either metal or wood-working; shipping facilities unexcelled. Two trunk lines; direct connections east, west, north and south. Educational advantages the very best. Plant will be sold at a bargain and on easy terms of payment, if desired. Apply Box 294, Canadian Machinery. c2m

SITUATIONS WANTED

HIGH-GRADE MAN, EXPERIENCED IN General construction, manufacturing, machine shop work and heavy shells, is open for a good offer only. Box 315, Canadian Machinery. c25m

PRACTICAL WORKS MANAGER AND Mechanical expert with years of experience in United States and Canada, a specialist in munition work, open for engagement. Best of references. Apply Box 304, Canadian Machinery. c4m

ELECTRICAL ENGINEER — COLLEGE GRADUATE, five years' practical experience; now employed in large industrial plant, electric-driven; responsible position desired; money not sole object; recommendations. Box 305, Canadian Machinery. c26m

What have you to sell?

Have you old or used machinery or any equipment for which you have no further use, or are your services for sale?

If your proposition will interest the men or the firms we reach, the logical place for it to appear is in these columns.

Canadian Machinery
Classified Advertising Section
143 University Ave., Toronto, Ont.

WANTED

300-TON PRESS SUITABLE FOR NOSING 4.5 Howitzer Shells, complete with triple pump, accumulator, and fittings. McGregor & McIntyre, Limited, 1139 Shaw St., Toronto, Ont. c26m

WANTED — THREAD MILLER FOR NOSE OF 4.5 mark VII. shell. Must be in good order and price reasonable. J. C. Wilson & Co., Belleville, Ont. c26m

SITUATIONS VACANT

WANTED — TOOL MAKERS TO WORK ON munitions. Apply at once. Wallaceburg Brass & Iron Mfg. Co., Ltd., Wallaceburg, Ontario. c25m

ADVERTISERS DESIRE TO GET IN TOUCH with traveller calling on manufacturers, etc., to solicit work for well equipped machine, tool-making and repair shop. Good proposition to right party. Box 319, Canadian Machinery. c25m

THOROUGHLY CAPABLE BRASS FOUNDRY Foreman to take charge of small foundry doing a general jobbing business and also munition work. Location Montreal. Address for information, "Brass Foreman," P.O. Box 1934, Montreal. c26m

WANTED — TWO EXPERIENCED BORING lathe hands to take charge on day and night shifts, of battery of boring lathes for 6" Mark III shell. Only men who can get good bores and high production need apply. Give in the first instance, experience, wages required and full particulars, otherwise application will not be considered. Box 317, Canadian Machinery. c26m

HOISTING MACHINERY SALESMAN, Between ages of 30 and 40; prefer, if possible, man having experience machine shop, drafting room, general office, as well as actual selling. Man of sound training and good judgment assured steadily increasing salary and good future. Reply, giving all needful information in few words, to Box No. 318, Canadian Machinery. c25m

TECHNICAL ADVERTISING MAN — LARGE manufacturing concern near Toronto, building a general line of heavy machinery, requires a young man to take care of its advertising; must be able to prepare machine descriptions from blue prints and to write clear, concise English; advertising experience desirable, but not necessary; please state age, nationality, experience and salary desired, and send samples of your work with first letter. Box 320, Canadian Machinery. c26m

6" SHELL FOREMAN WANTED WITH Special qualifications to get production from shop at Peterborough, Ont., which has been running on 6" shell for eighteen months. Tooling and shop inspection separately organized. Foreman to give his whole attention to obtaining maximum production. Give full particulars in first application as to previous experience, references, and salary required, otherwise application will not be considered. Apply to Box 316, Canadian Machinery. c25m



BERTRAM MACHINE TOOLS

ACME BOLT CUTTERS

All Standard Sizes from
1/2-inch to 6-inch Capacity

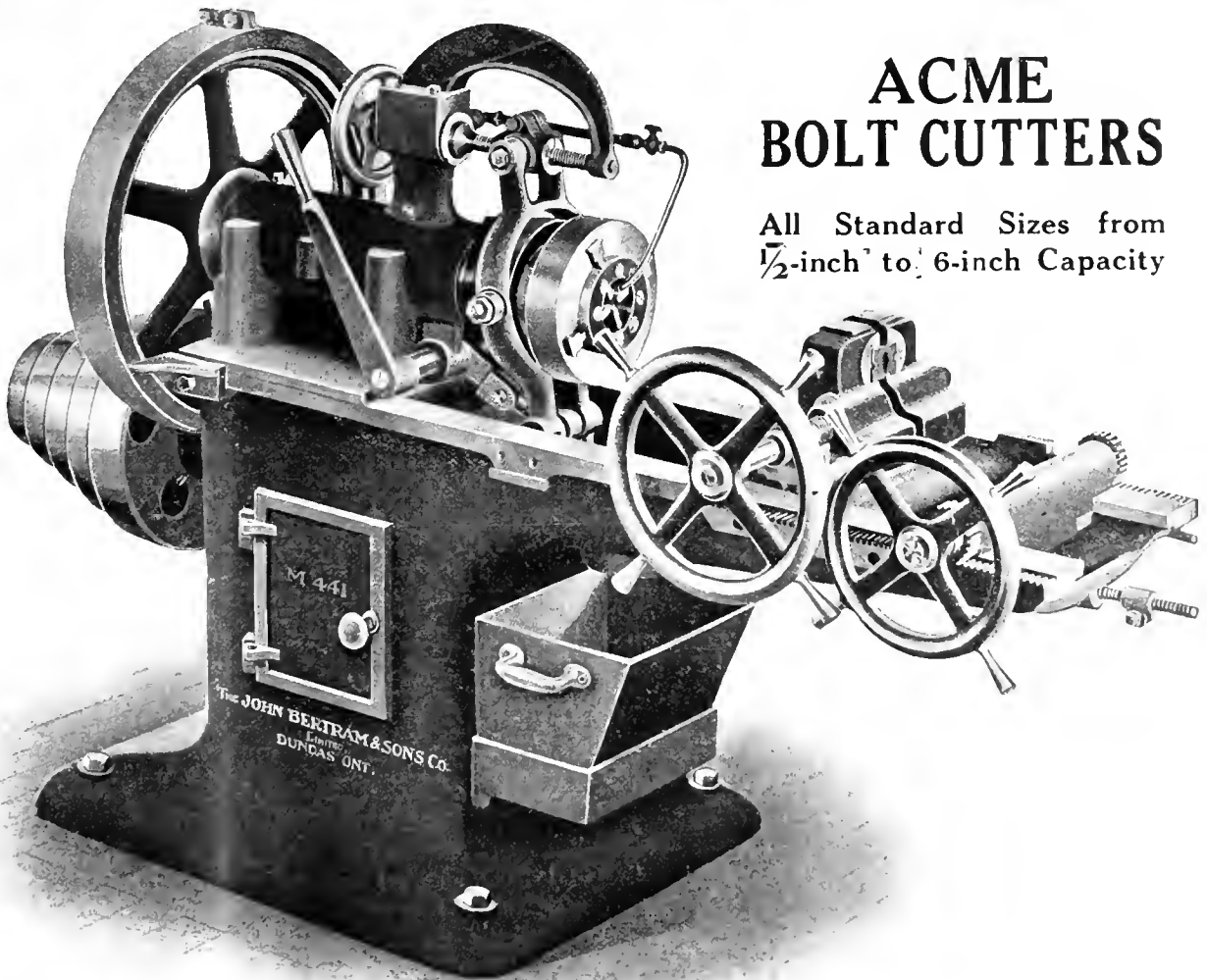

Supplied with Leadscrew Attachment for Stay Bolts or other work requiring special Accuracy of Pitch.

WRITE US FOR FULL DETAILS ON ANY MACHINE OR MACHINES IN WHICH YOU ARE INTERESTED

The John Bertram & Sons Company Limited

Dundas, Ontario, Canada

MONTREAL
723 Drummond Bldg.

TORONTO
1002 C.P.R. Bldg.

VANCOUVER
609 Bank of Ottawa Bldg.

WINNIPEG
1205 McArthur Bldg.

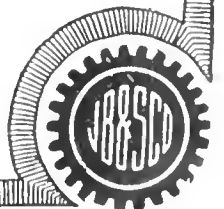

If any advertisement interests you, tear it out now and place with letters to be answered.

The Publisher's Page

TORONTO

June 28, 1917

Advertising as the Quick Rescuer in England's Crises

What It Has Done and How the Government Proved Its War Time Use.

By J. Murray Alison

Formerly Advertising Manager of the London Times, late Assistant Director of Recruiting, Royal Naval Division

MANY of the men who have enjoyed your overflowing hospitality in happier days gone by are in the trenches, the dust of many lies quiet in France, others in khaki or navy blue guard those little islands in the North Sea, many, also in uniform, are in the War Office, the Admiralty or in the Ministry of Munitions, while the rest, in the plain clothes of the civilian, still carry on their craft, a craft now devoted to the common object of us all, the winning of the war.

For, let there be no mistake, advertising plays a very important part, indeed, when war becomes, as this war has become, not merely the clash of armed forces, one against the other, but a conflict between whole peoples, a conflict between two separate and distinct theories of government, of civilization, even of existence itself. That advertising does play this important part in such a conflict as the one that has held almost the entire world in its grip for nearly three years is no theory. It is no bombastic utterance; it is plain and sober fact. It has been proved without any shadow of possible doubt, and this brings me perhaps in a roundabout way to the subject that stands against my name in to-day's programme, "What Advertising Has Done for England." What advertising has done so far may be tabulated very briefly:

It raised four million fighting men under the voluntary system.

It raised countless billions of dollars in loans floated in England.

It raised nearer \$200,000,000 than \$100,000,000 in private donations for the various war charities, the majority of which were and are still being run by advertising men.

It discovered to the authorities over a million men whose trades and their knowledge of those trades made them skilled ammunition workers.

It persuaded over a million women to offer their country the labor of their hands to release the male workers for other duties.

Advertising taught the people of Great Britain to work harder and produce more, to give up their useless luxuries when it was necessary to consume less petrol, less rubber and less food; it taught the British people the sin of waste and the glory of sacrifice.

WHAT WOULD HAVE HAPPENED WITHOUT ADVERTISING.

Now there is always a great danger in overstatement, and in case there are those who might say that I am "drawing the long bow" in making these claims for advertising, let me say straight away that I do not claim that advertising accomplished all these things by itself. The war itself is bigger than advertising, naturally, and it was the occasion, the tremendous occasion, that counted. But consider what would have happened without advertising. What would have been the position of the Allies six months after the war started? What would have been the position a year afterwards? What would have been the position to-day?

We can only come to a judgment of these questions by negative speculation. It is perhaps a clumsy method, but it is the only method available, and such as it is I propose to employ it.

You must remember that while those great advertising campaigns were in progress the Allies were on the defensive; they were just holding on. Every man, every shell, every gun, every munition worker, every woman worker counted enormously. Imagine what would have happened in that terrible year of 1915 had there been a really serious shortage in men and money, in addition to the temporary shortage of munitions.

During those fateful days of 1915 a shortage of 50,000 men on the Western front, especially at the second battle of Ypres, would have meant disaster to the British army. The British generals were short enough, God knows, but not too short to hold the line. Thanks to advertising, the men were there in sufficient numbers, and thanks to their heroism, the line was held.

Again take what the shortage of munitions meant in those same months, when every projectile was worth its weight in solid gold. What happened then? There was formed the great Ministry of Munitions. That ministry, with Lloyd George at the head of it, bought land and factories and iron and steel, but what was the good of all this material without the men to work and weld it into guns and shells? The men were there; they were in England somewhere. The problem was to find them and take them from the cycle factory, the piano works, from any place, in fact, where men were used to work in metal, and to collect them and parcel them out to man the factories that were waiting to receive them. That was no easy task. How was it accomplished?

One of the first appointments made in the new Ministry of Munitions was that of advertising director, who advertised for the men and got them, and a few months afterwards the men at the front were no longer short of munitions and never have been since. Advertising never yet made a shell or a fuse or a cap or an ounce of picric acid, but it delivered into factories easily, without friction and quickly, all or nearly all the available men who could do these things. Supposing that the government had decided not to try the advertising experiment,

supposing that the government had been forced, in those dark days when for a whole year not one solitary item of good news reached the British people, to raise the men for the front and the men for the back of the front by other means.

Imagine what would have happened had the government been forced at that time to introduce some measure of conscription of fighting men, of working men and of capital. That the country would have ultimately risen to the occasion I have, of course, not the slightest doubt, but there is also no room for doubt that such legislation would have met with the greatest opposition and the energies of the nation would have dissipated in a domestic political struggle with what result I dare not even suggest.

Without advertising there would have been volunteers in their hundreds of thousands, without advertising capital would have been forthcoming in millions, but men were needed, not in hundreds of thousands, but in millions, and money was needed, not in millions, but in billions; the people did not know what they were up against—it was the business of advertising to make them understand.

WHAT SUCCESS OF WAR LOAN MEANT.

I do not think, however, that it is necessary for me to spend any more time in proving that advertising did all, and more than all, its advocates claimed that it would do. The fact is that in England it has been employed to accomplish, easily and quickly, do not forget that last word, *quickly*, each and every purpose of the government. Perhaps, however, I may be permitted to refer to another campaign, especially as a similar campaign is now being launched in this country. I refer to the campaign conducted on behalf of the second war loan late in 1915. If I remember rightly, it was a three-billion-dollar loan. It was not the intention of the government to advertise this loan, and the usual "peace time" single-column spaces were issued to the newspapers. I remember my astonishment at seeing the old familiar column in *The Times* one morning, and you may depend upon it that I didn't waste much time in getting in touch with the official government agent. I remember, also, his alarm at my suggestion that the loan should be advertised like bags of flour or tins of tobacco. I may tell you now that in that first week the loan was a failure. It was not that the people were not patriotic, but the days were too big for the old methods, and in the crash of events at the front the old stereotyped announcement was lost.

As it was, the loan was about to be a failure, and would have been a failure had not the government taken the suggestions of the little group, the little group of willing men, who were advising on advertising generally.

Assume that the government had decided not to advertise the loan and the three billion dollars asked for had not been forthcoming, what would have happened? In the first place, the British Empire would have lost credit throughout the world, the men in the trenches across the Channel would have been disheartened, not to say disgusted, and the enemy would have every grounds for claiming that the strongest and richest member of the Entente was quitting. As it was, something quite different happened. The loan was heavily advertised and easily and *quickly*, to be precise, in fourteen days after the advertising started, the loan was over-subscribed; and, instead of being partially discredited in the eyes of her Allies and in the opinion of the world, instead of giving comfort to the enemy, Great Britain was able to encourage her soldiers, cement the alliance and deliver a blow to the powers arrayed against her.

It is needless for me to remind you that in this war political and moral considerations are almost equal to those of purely military significance, and the success of the second war loan was as great a victory to the Allies as the capture of a fortress on the Western front. As a matter of fact, it was the only positive victory that the Western Allies had that year.

It was not always easy to persuade the various departments of government to allow us to aid them. My own experience was limited to the Admiralty, and I shall never forget my first interview with the shy and retiring, though gallant, men who lurk in the dark chambers of that edifice. On that occasion I felt almost as scared as I now feel. I had elaborated my plans for increasing recruiting at some length, and when I had concluded a distinguished Admiral said, "Are we to understand, sir, that you desire to boom the navy in some manner?" to which I replied, "That, Admiral, would be my purpose." There was a short silence, then the gallant sailor replied, "You are evidently not aware, sir, that the Royal Navy is known as the silent service."

After the experience (on the second war loan), however, there was no need for us to have to persuade the authorities as to the value of advertising. As I have said, it has been employed ever since for every purpose that the government has sought to accomplish.

Extract from address before St. Louis Convention, A.A.C. of W.

Quality

Service

LIST OF PRODUCTS

“Hamilton” Pig Iron
Open Hearth Steel Billets
Steel and Iron Bars
Forgings
Railway Fastenings
Pole Line Hardware
Bolts, Nuts and Washers
Wrought Pipe
Screws, Wire
and
Wire Products
of every description

**THE
STEEL COMPANY
OF CANADA
LIMITED
HAMILTON MONTREAL**

If any advertisement interests you, tear it out now and place with letters to be answered.

In the "Iron Grip" -- But Too Hard to Hurt

SKF BALL BEARINGS



Only a dent in the vise—that's all. The Crucible Steel Balls used in S K F Ball Bearings are so hard and resilient that they will not crush under this most severe test.

If you try to crush a 1/2" S K F Ball by squeezing it in a vise, you would have to exert a pressure equal to a load of 33,000 lbs. Literally, they are a tower of strength and hardness.

When you want a bearing that is strong, wear-proof,—specify S K F. Our Engineering Service Department will gladly give you information about S K F for your machines.

CANADAIN SKF COMPANY
TORONTO LIMITED CANADA

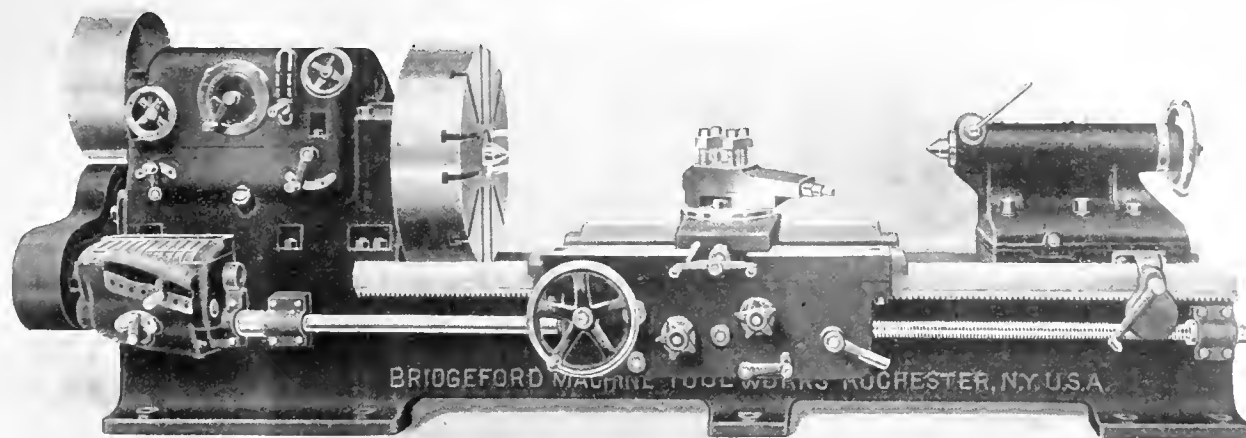

Bridgeford 36" Patent Geared Head Lathe HEAVY PATTERN

Accurate

This is one of those heavy duty "Bridgefords," celebrated for its accuracy and speed. Has ideal combination of cutting speeds and changes are made with quickness and ease. You can bank on this lathe to go through the toughest proposition in quick order where the average lathe would fall down.

All Bridgeford Lathes are built to cope with the severest requirements. Let us tell you more about them.

Bridgeford Machine Tool Works, Rochester, N.Y.

161 WINTON ROAD

DOUBLE MUSHET

High Speed Steel

Carbon Steel

Gauge Steel

Alloy Steels

SOLE MAKERS

Samuel Osborn & Co. Ltd.
SHEFFIELD



*Twist Drills and
Reamers, Milling
Cutters and Slit-
ting Saws*



Sam'l Osborn (Canada)
Limited

Head Office and Works: Montreal, P.Q.

Branch Office: Toronto, Ontario

If interested, tear out this pr it out now and place with letters to be answered.

STELLITE

IS NOT STEEL, SO DO NOT
∴ USE IT LIKE STEEL ∴

DIRECTIONS FOR GRINDING "STELLITE" TOOLS

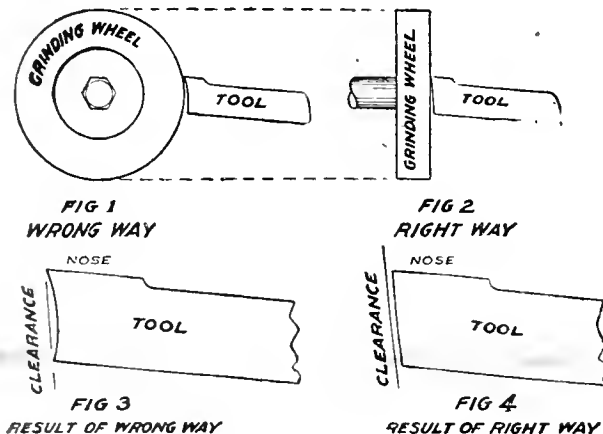
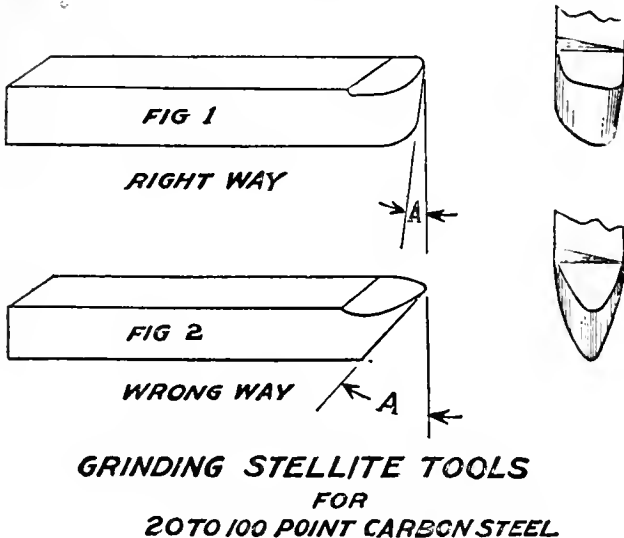
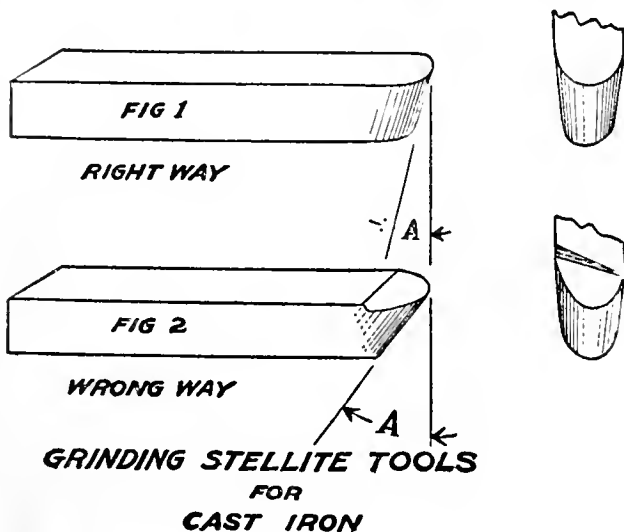

Figure 1 shows the right way to grind a Stellite tool for machining Cast Iron. Give the tool a full Round Nose, and be sure the angle (A) is just sufficient to allow the tool to clear the work. This angle should never be more than six degrees.

Whenever possible, operate the tool without top slope as shown in Figure 2, since the centre of the Stellite bar is not as hard as the outer surface.

Figure 2 shows the improper way to grind the tool. Angle A is entirely too great, and will cause the tool to crumble. This tool should have a full round nose, and the top slope as shown will reduce the cutting qualities of the tool.

Stellite tools cannot be burnt while grinding, because they have no temper. They always remain hard.

Always use No. 3 grade Stellite for turning Cast Iron.

Figure 1 shows the right way to grind Stellite tools for grinding steel. Angle A should be just sufficient to allow the tool to clear the work, and should never be more than six degrees. In turning steel it is necessary to give the tool some top slope to get the proper cutting action between tool and chip. It will be found that due to the high rate of speed at which the Stellite tools operate it requires less top slope than is generally given other tools. A top slope angle of 5 degrees is sufficient.

Figure 2 shows wrong way to grind for turning steel, as Angle A is too great and the shape of the cutting nose is too pointed. The top slope, as shown in figure 2, is too great.

Always use No. 2 grade Stellite for turning 20 to 100 point Carbon Steel.

In Figure 1 the Stellite tool is being ground on the periphery of the grinding wheel, with results as shown in Figure 3. This method is wrong, because a concave clearance is given the tool, as shown, which robs the cutting edge of its maximum support, causing crumbling and failure.

In Figure 2 the Stellite tool is being ground correctly, using the side of grinding wheel. This method gives maximum support to the cutting edge as shown in Figure 4.

Tools ground, as shown in Figure 3, will always give trouble, and are responsible for most failures with Stellite tools.

Never give Stellite tools any more clearance than absolutely necessary.

Always remove the wire edge with a carborundum or oilstone.

Stellite cuts 25% to 300% faster than the best tool steel.

CANADIAN MANUFACTURERS

Deloro Smelting & Refining Co., Limited

DELORO, ONTARIO

Branch Warehouses - TORONTO and MONTREAL.



Steel Castings

Manganese,
Vanadium,
Titanium,
Chrome,
Nickel
Castings

Made in sizes
from 1 lb.
to
50 tons

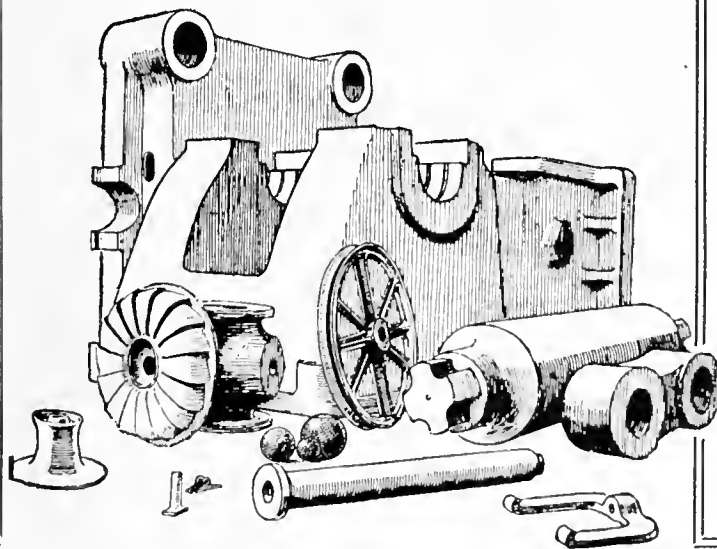

Springs

If you are in the market for springs, let us have your specifications. Our product is second to none and we are in position to deliver promptly.

Rolling Mill Rolls

Our rolling mill rolls are par excellence. It is our conviction that we can meet your requirements in a most satisfactory way.

CANADIAN STEEL FOUNDRIES.

Limited

MONTREAL

WELLAND



If any advertisement interests you, tear it out now and place with letters to be answered.

The Johnson Friction Clutch Is Being Used As A Part Of This Machine

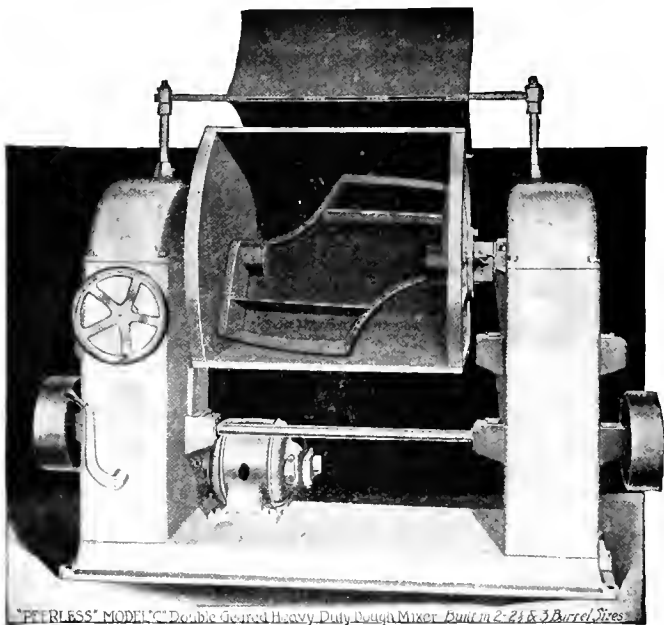

"PEERLESS" MODERN "C" Double Geared Heavy Duty Dough Mixer Built in 24 & 3 Barrel Sizes

Courtesy The Peerless Bread Machine Co., Sidney, Ohio.

For Your Own Machines—

Have you thought of incorporating clutches? You know that people are known by the company they keep. So are all other things. Have you noticed the machines the JOHNSON FRICTION CLUTCHES are associated with? Let us introduce you to clutch satisfaction. THE JOHNSON FRICTION CLUTCH, so your machines may become acquainted. Write us about your requirements to-day.

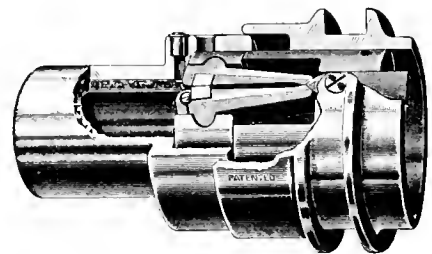

Single Clutch Interior

THE CARLYLE JOHNSON MACHINE CO.
MANCHESTER, CONN.

England—The Efadem Co., 159 Gt. Portland St., London. W., England. Sole Agents for the British Isles.
 Canada—Williams & Wilson, Ltd., 320 St. James St., Montreal. Canadian Fairbanks-Morse Co., Limited, Toronto.
 AUSTRALIA—George Wills & Co., Brisbane, Queensland.

If any advertisement interests you, tear it out now and place with letters to be answered.

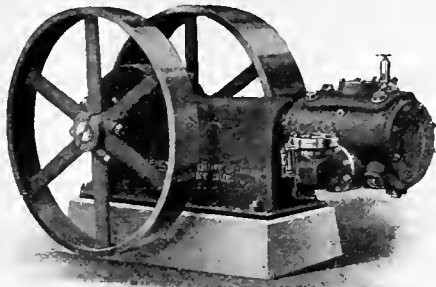

Jenckes Class CB-1 Air Compressor
Single Stage

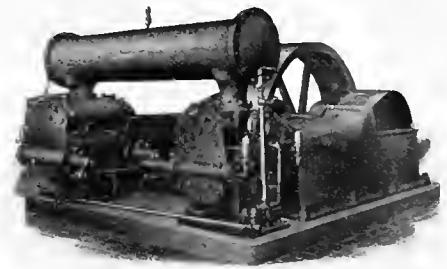

Jenckes Class DB-2 Air Compressor

Inlet valves are of the Corliss type, the outlet valves of the disc type. Lubrication is of the flood type, that is a continuous flood of oil is flowing over the bearings, crank pins, etc., all the time when the machine is in operation. Machine enclosed.
Write for full particulars.

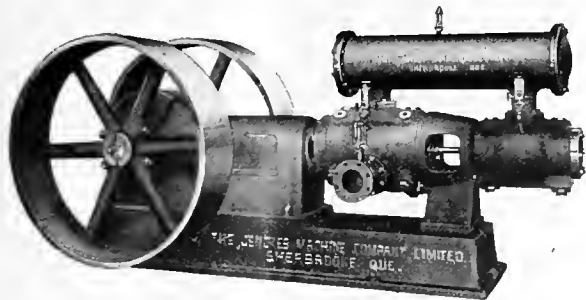

Jenckes Class CB-2 Air Compressor
Two Stage

Our CB-1 and CB-2 compressors are equipped with disc inlet and outlet valves, which gives them long life and high efficiency, and makes them noiseless running. The machines are entirely enclosed. Lubricating system is of the splash gravity type, and the bearings are extra large.

JENCKES AIR COMPRESSORS

The design and construction throughout are of the highest class, the machines being built to successfully stand severe and continuous service. A Jenckes compressor is a paying investment. Write for full descriptive matter.

OTHER LINES

Boilers, Engines, Hoists, Pulp Mill Machinery, Stamp Mills, Ore Cars and Special Machinery.

Write for complete description and deliveries.

The Jenckes Machine Company, Limited

Sherbrooke, Montreal, St. Catharines, Toronto, Cohalt, South Porcupine, Vancouver

Works: SHERBROOKE, QUE.

ST. CATHARINES, ONT.

If any advertisement interests you, tear it out now and place with letters to be answered.

TURN OUT More Shells

The Corbet Improved Heavy Turret Lathes will Help You

The "Corbet" Lathe will render you a service that will show immediate results in an increase in your output

Repeat orders from users give evidence of the valuable service these lathes are giving.

The "Corbet" Lathe has an Automatic Chuck and Large Hollow Spindle to accommodate shells up to six inches diameter.

Moderate prices. Write for particulars. **PROMPT DELIVERIES.**

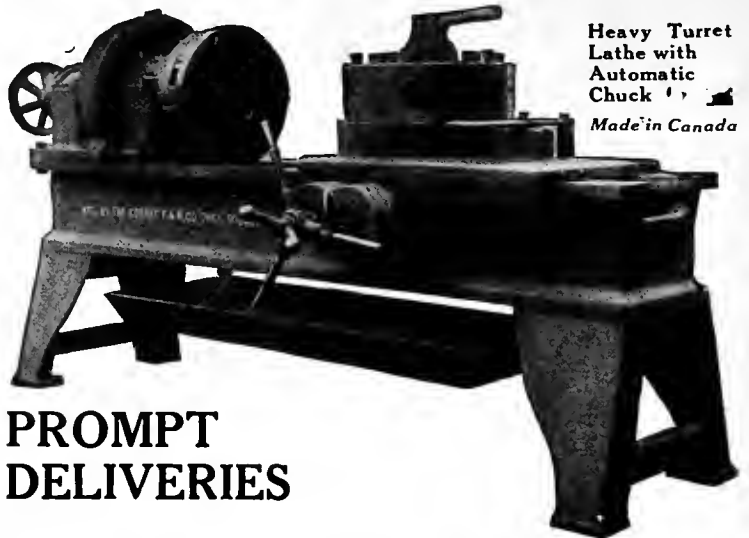

Heavy Turret Lathe with Automatic Chuck
Made in Canada

PROMPT DELIVERIES

The Corbet Automatic Steam Towing Machines for Tugs and Barges

You can soon pay for one of these machines with the money saved in not having to buy new hawsers every Spring. Steel Hawsers will last ten years whereas the Manila Hawsers lasts only one season. With a Corbet Machine you can use the Steel Hawsers. Made in four sizes to accommodate steel hawsers from 3/4" dia. up to 1 1/2" dia. Now is the time to place your order for delivery April 15th, 1917.

Write for prices and general information.

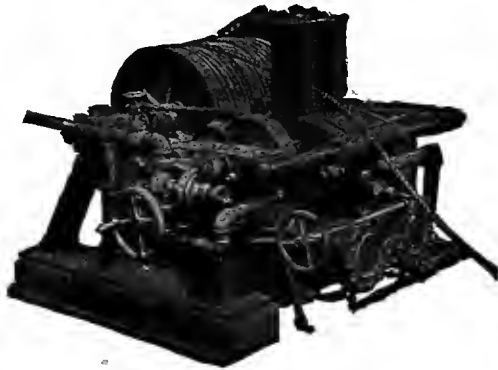

Steam Towing Machine
MADE IN CANADA

The Corbet Foundry & Machine Co., Ltd.

Owen Sound, Ontario, Canada

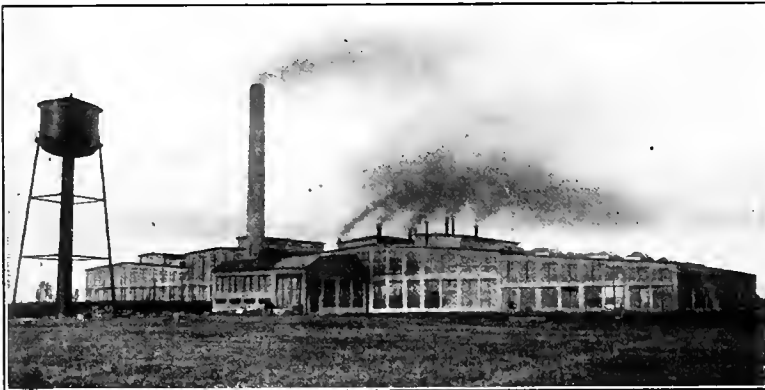

Works: LONGUEUIL, QUE.

Armstrong Whitworth

of Canada, Limited
MANUFACTURERS OF

HIGH SPEED STEEL
CARBON AND ALLOY STEEL
MISCELLANEOUS SHOP TOOLS

HEAD OFFICE: 298-300 St. James St., Montreal

Dominion Bank Bldg., TORONTO
Branches: 27 King William Street, HAMILTON
McArthur Bldg., WINNIPEG, MAN.

All Products "MADE IN CANADA"

PIG IRON

"Victoria"

Foundry and Malleable, made by The Canadian Furnace Co., Port Colborne, Ont., Canada.



M.A. HANNA & Co.

Sales Agents:

Toronto
Cleveland, Buffalo, Pittsburgh, Detroit

Sheet Metal Working Machinery of any description



NO 7 SCREW PRESS

For

Quality Efficiency
Durability Speed
they are unsurpassed.

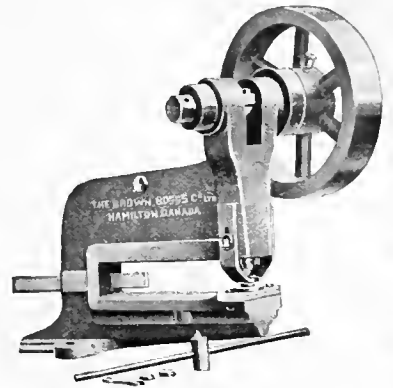

NO 100 GEARED
POWER PUNCH

The Brown, Boggs Company, Limited

Hamilton, Ont.

Manufacturers:

Tinsmiths', Heavy Sheet Metal
Working Machinery, Canners'
and Evaporating Machinery.

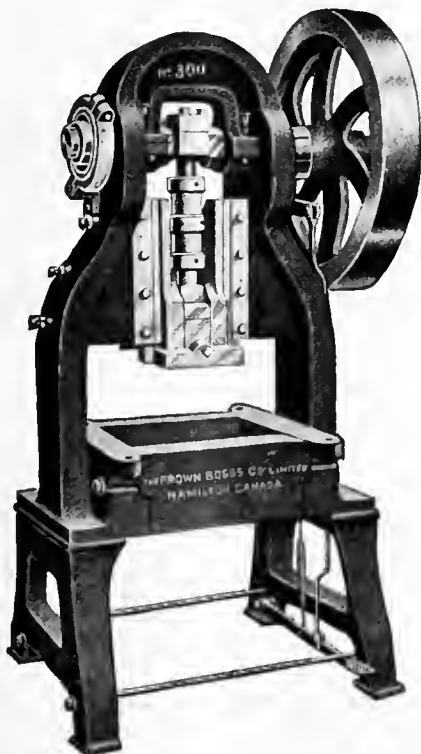

NO. 300 ARCH PRESS

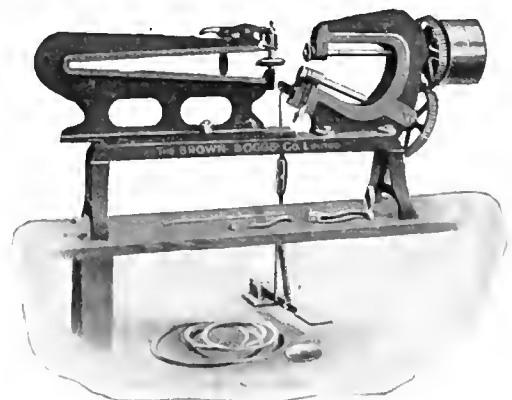

NO. 6 COMBINED
RING and CYLINDER SHEARS

If any advertisement interests you, tear it out now and place with letters to be answered.

ESTABLISHED 1870

W^{M.} ATKINS & C^{O.} L^{TD.}

TRADE MARK



Reliance Steel Works
SHEFFIELD, ENG.

TRADE MARK



TRADE MARK

*of the Famous***“WACO”**

Brand

High Speed Steel and Twist Drills**“DOUBLE WACO” Quality**

Specially Adapted for all kinds of
AMMUNITION WORK

“Turtle” Brand
High Class Tool Steel, Files, etc.
of all descriptions.

For particulars apply to our
Sole Representatives for Canada

GEO. A. MARSHALL & CO.

70 Lombard Street Toronto, Ontario



Mention this paper when writing advertisers. It will identify the proposition about which you require information.

MANUFACTURING STEEL SPECIALISTS

ANNOUNCEMENT

The Fairley-Davidson Steel Company are not merely manufacturers of steel, but steel specialists of the highest practical and technical attainment with more than twenty-six years' experience.

We guarantee to supply the correct steel at once for any purpose, thus eliminating costly experiments.

Our success has convinced our patrons we are capable of overcoming the worst difficulties. Invariably, we succeed on work called impractical and after the ordinary steel manufacturer has given up.

Our mills are equipped with the most modern machinery for the manufacture of high grade crucible and Siemen, acid steels, in billets, bars and forgings.

Our New York stock aggregates more than 300 tons of steel for the various requirements.



LARGE STOCKS carried at New York warehouse, in
Tool and Die Steel — Fondwot and Giant
High Speed Steels — Rushitoff and Xtof
Hot Working Steel — Precision
Chrome Vanadium
3½% Nickel } "Hchtemnd"
Chrome Nickel

**The FAIRLEY-DAVIDSON
STEEL COMPANY, Inc.**

Office: 124 Maiden Lane, New York City

Canadian Sales Agency:

**THE CANADIAN UTILITIES STEEL &
ENGINEERING, Limited**

151 Craig Street West

Montreal, Canada

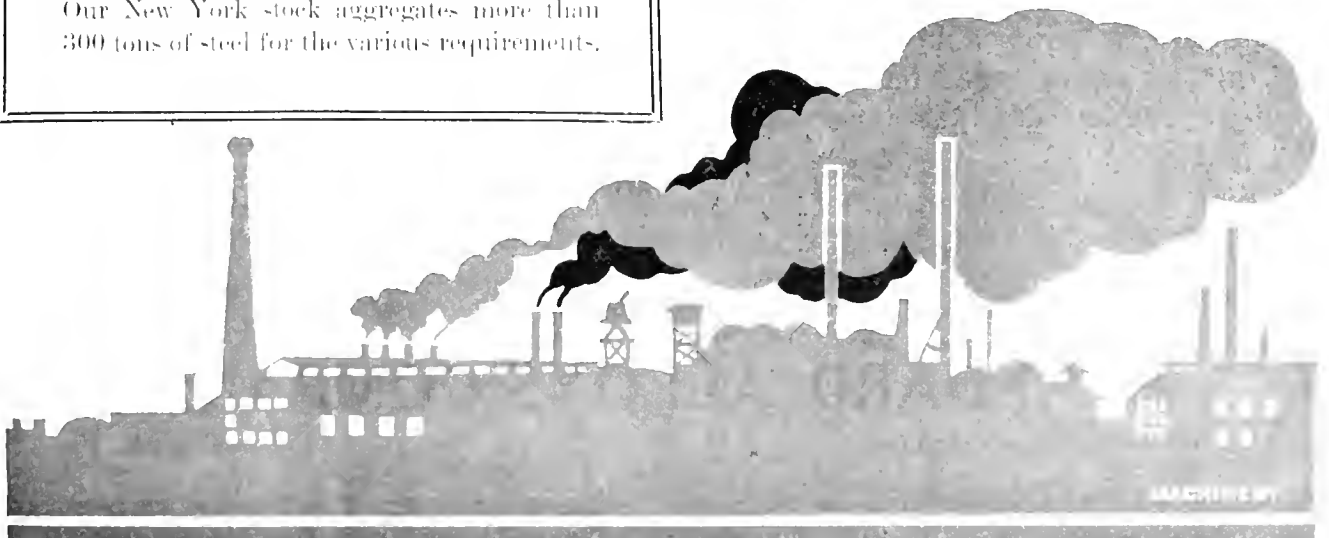

If any advertisement interests you, tear it out now and place with letters to be answered.

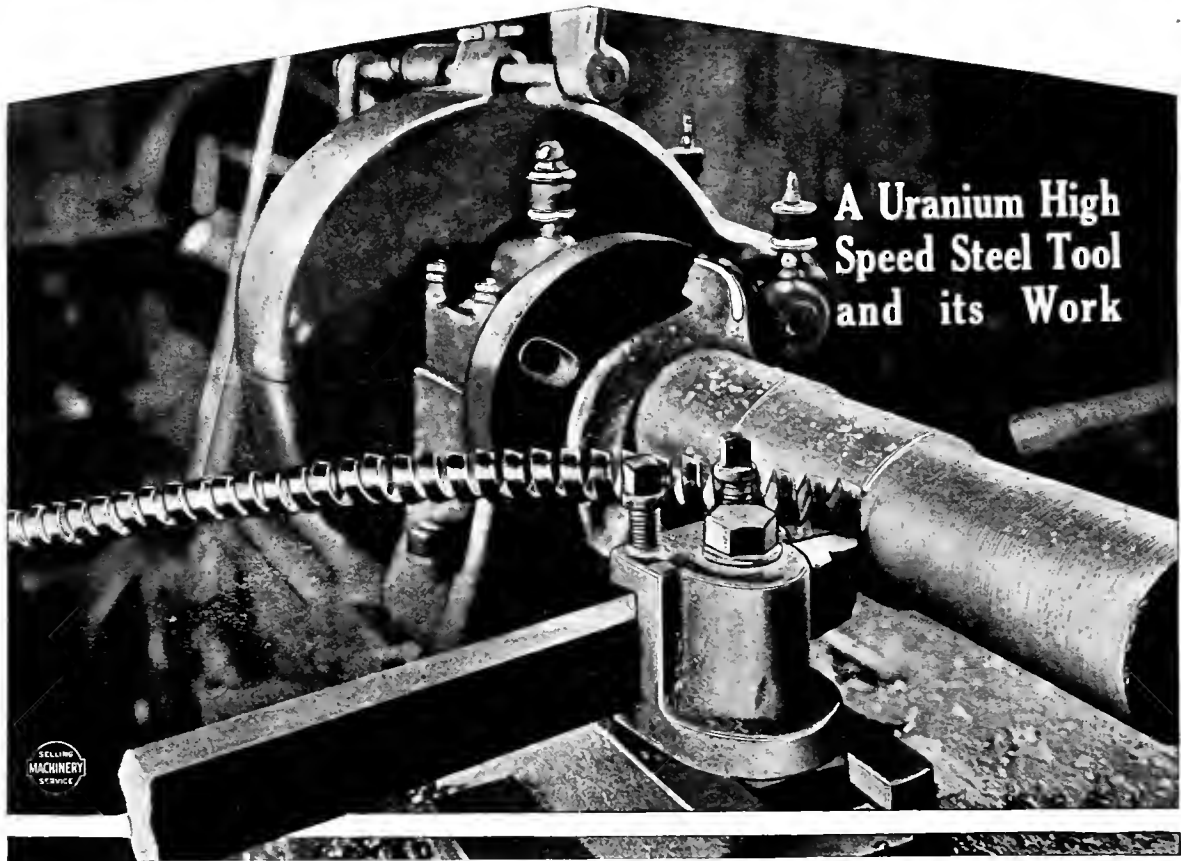

FOR BETTER TURNING TOOLS SPECIFY

URANIUM HIGH SPEED STEEL

Its use in high-speed turning tools means longer service between grinds, the ability to stand heavier cuts and coarser feeds and greater "all around" economy. The photograph shows a Uranium Steel Tool, one inch by two inches, turning a heat-treated steel shell forging 4.5" diameter, taking a quarter-inch cut at a feed of $7/32$ " per revolution. The chip coming off is so tough it can hardly be bent with the hands.

If you want better service from high-speed steel tools, regardless of the work they do, specify Uranium High-Speed Steel. Improvement will date from the first job they finish.

Consult your steel man or write us.

STANDARD ALLOYS COMPANY

Forbes and Meyran Avenues

Pittsburgh, Pa.



VULCAN

Special Vanadium Steel

In three separate runs, each of these dies drew over
50,000 brassshells **WITHOUT BEING REHARDENED**

They made

178,000 SHELLS PER DIE

After rehardening they were as good as new.

Vulcan Crucible Steel Co.

ALQUIPPA

Established 1900

PA., U.S.A.

Represented in Canada by Messrs. Norton, Callard & Company, Montreal

If any advertisement interests you, tear it out now and place with letters to be answered.

CO CO TURNING STEEL TOOL HOLDER BITS "THE BIT WITH THE GROOVE"



What CoCo is Doing on Other Jobs

"CoCo" will do the same in your shop,—will cut faster or longer than other steels. Here are some proofs:—

"CoCo" is cutting Semi-steel Castings at 100 ft. per minute, cut $\frac{1}{2}$ " deep. 30 hours continuous service between grinds.

"CoCo" is turning Cast Iron Hydrant Caps at 169 ft. per minute, feed $\frac{1}{8}$ ", cut $\frac{3}{8}$ " and turns 4 hydrants per grind where less than one per grind used to be standard.

"CoCo" is turning .40 Carbon O. H. Forged Rams at 95 ft. per minute, feed $\frac{1}{4}$ ", cut $\frac{3}{32}$ " turning 3 rams in the same time it formerly took to do one.

CAN YOU BEAT IT?

CoCo Steel does not do stunts—It does the work. It will do yours as well. Ask us.

COLONIAL STEEL COMPANY

PITTSBURGH

BOSTON

DETROIT

NEW YORK

PHILADELPHIA

ST. LOUIS

CHICAGO

If any advertisement interests you, tear it out now and place with letters to be answered.

FIRTH'S

"SPEEDICUT" HIGH SPEED STEEL

FOR MACHINING SHELLS

Also STANDARD brands of Firth's CARBON TOOL STEEL. Sold in every country where Steel is used.

We also Manufacture:

Armour-Piercing and High Explosive Projectiles; Forgings of every description for Heavy Ordnance, Propeller Shafts, Turbine and Engine Work, etc.

Nickel, Nickel-Chrome and other Alloy Steels.

Tyres, Sword and Bayonet Steel, Bullet-Proof Steel for Armoured Cars, Aeroplanes, etc.

Cutlery Steel, Stainless Steel for Cutlery, etc. (Originally discovered by our Research Dept. in 1913.)

Mining Drill Steel, Shoes and Dies, Files and Rasps, etc.

Thos. Firth & Sons, Limited

Norfolk Works and Tinsley Works
SHEFFIELD, ENGLAND

Works also at Riga, Russia; McKeesport, Pa., and Washington, D.C.

CANADIAN WAREHOUSES:

449 St. Paul St. W., MONTREAL J. A. Sherwood,
79 Adelaide St. W., TORONTO Canadian Manager



13 1/2 inches Diam.



Weight 1,400 lbs.

If any advertisement interests you, tear it out now and place with letters to be answered.

STEEL

FOR SHRAPNEL SHELLS AND SHELL BLANKS

We are the only company in Canada producing steel ingots by the "HARMET" Liquid Process, a process that makes these ingots vastly superior to the ordinary kind, improving the physical properties and reducing the waste of ingot.

We can supply forgings of all shapes and sizes made of ordinary or "HARMET" Fluid Compressed Open-Hearth Steel on the Shortest Notice.

Nova Scotia Steel and Coal Company Limited

Head Office: NEW GLASGOW, N.S.

Western Sales Office:
Room 14, Windsor Hotel, MONTREAL

"Independence" Die Steel

is produced from the purest hammered Swedish Charcoal Iron by workmen whose families have for several generations been occupied exclusively in the production of this specialty, and is a quality which has been manufactured for nearly a century and a half without change.

You get extra service from "INDEPENDENCE" DIE STEEL. A trial is convincing.

Manufactured by
**SANDERSON BROTHERS &
NEWBOULD, Limited**
SHEFFIELD, ENGLAND

H.A. DRURY COMPANY LIMITED

MONTREAL TORONTO NEW YORK

We guarantee shipment
within 24 hours of
receipt of order



"Extra"
"Special"
"High
Speed"

Tool Steels

Made in
Sweden
from selected
Dannemora Ore

We also carry in stock
Solid and Hollow Drill
Steel, Die Blocks, "SIS-
CO" Welding Wire, Drill
Rod and Swedish Iron.

Swedish Steel & Importing Co., Ltd.
MONTREAL, QUE.

High
Speed Steel
"ELECTRITE"

Made With
Uranium

By introducing Uranium into the manufacture of our High Speed Steel, we have achieved what users of High Speed Steel ere now had never even dared hope for. We have gained the greatest of metallurgical triumphs.

Electrite Uranium stands as a symbol of perfection in High Speed Steel.

Besides our different grades of High Speed Steel, we manufacture Permanent Tungsten Magnet Steel; "Select" Die Steel for hot work; "Mangano" non-Shrinkable Die Steel; "Renown" Special Die Steel for drawing dies; "Special" and "Extra" Water Hardening Carbon Steels.



Latrobe Electric Steel Company, Latrobe, Pa.

SALES OFFICES

165 Broadway, New York City
Monroe and Jefferson Streets, Chicago

40 Central Street, Boston
1st National Bank Building, Pittsburgh

1608 Jefferson Ave., Toledo
2230-2240 East Ninth Street, Cleveland

THE BANFIELD THREAD MILLER

For Milling inside and outside threads on Brass or Steel Sockets for Nose of 4.5--60 pdr., 6-in., 8-in. and 9.2-in. Howitzer Shells.

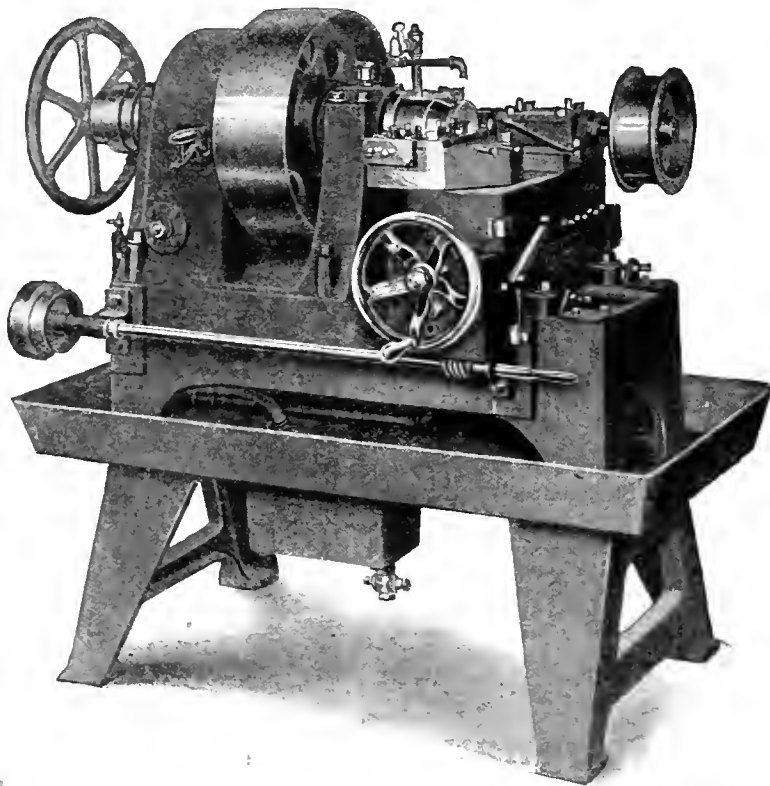
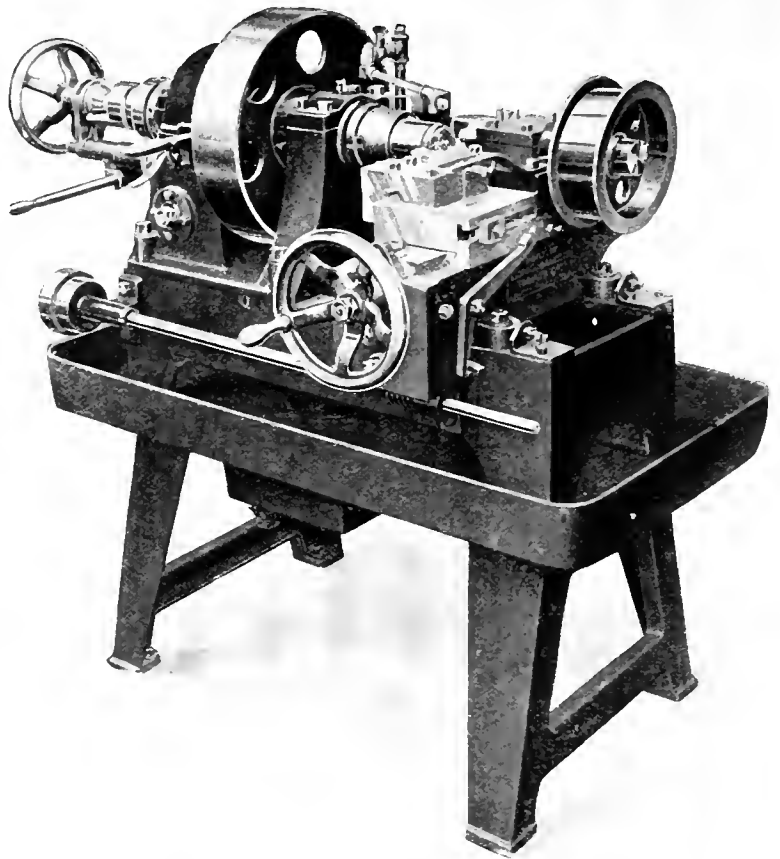

For Turning, Facing and Milling the thread on Gas
Check Plugs for 6-inch High Explosive Shells.

THE BANFIELD PLUG MILLER

Patented in Canada and United States

THIS machine is especially designed for finishing base plugs, turning the outside diameter, finishing the face with any camber desired, and milling the thread, all in one chucking, the complete plug being finished in six minutes by unskilled labor.

The machine is equipped with quick draw in collet. Drive pulley 18" x 6", with bronze bush having cut jaw clutch for turning and facing. Worm gear 100 to 1 ratio with cut jaw clutch for milling, driven by 10" x 1½" flanged pulley. The milling cutter is driven by an 8" x 2½" flanged pulley. Tool post carriage is equipped with power feed (two speeds) having automatic stop. Power feed pump with relief valve driven from worm shaft (all drives direct from main line shaft). Rigidly built, simple and economical to operate.

Weight 1,800 lbs.

For 18 pdr., 4.5 and 60 pdr. High Explosive Shells. Can furnish machines of same type, but somewhat lighter in construction. Particulars on request.

These machines are tooled up for finishing plain machined or beveled plugs, if desired.

Write for prices and deliveries.

Prompt Shipment

BUILT EXCLUSIVELY BY

Edwin J. Banfield
STAIR BUILDING, TORONTO, ONT.

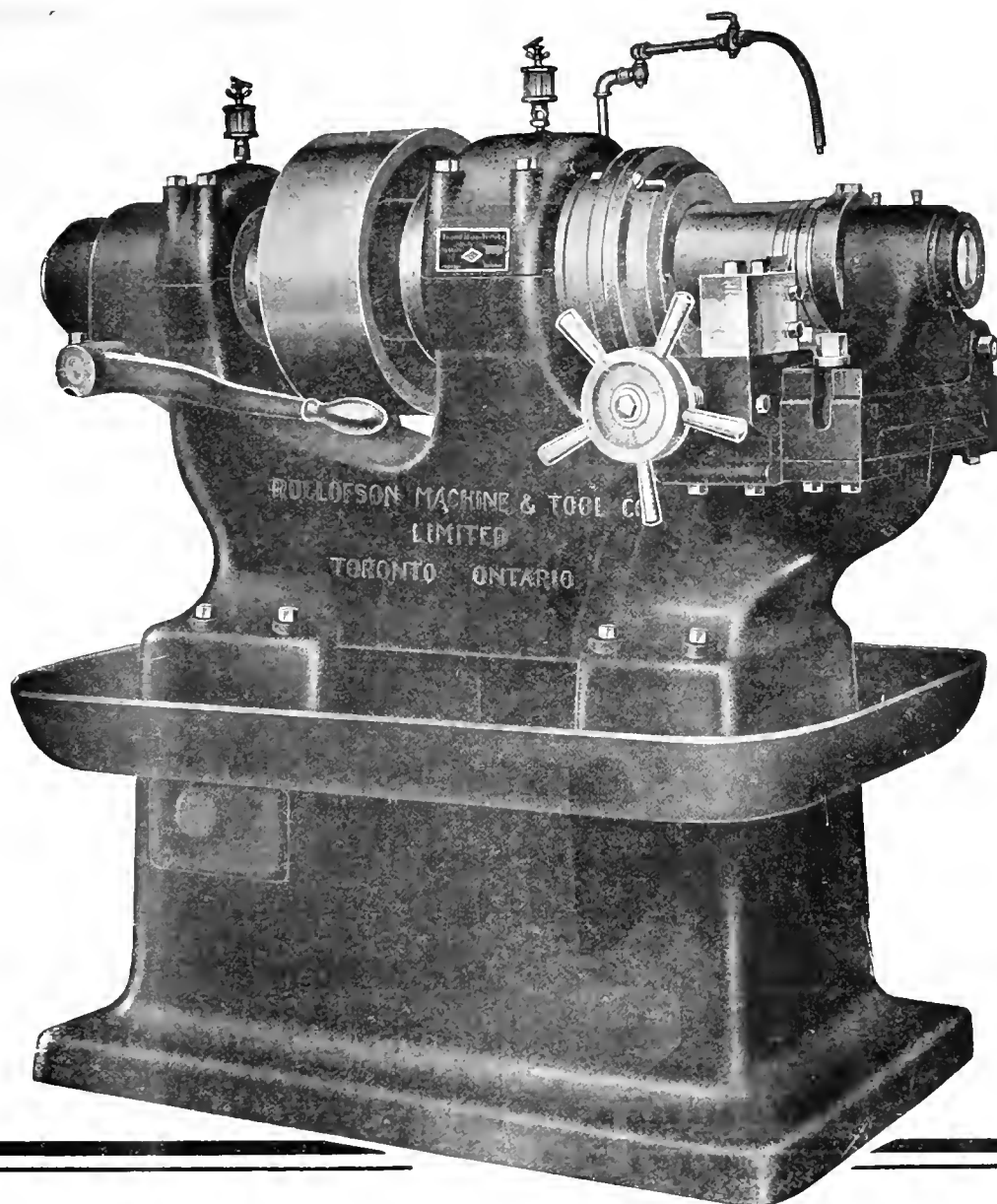

Just Now—

we have two 4.5 machines ready for immediate delivery

THIS Band Turning Machine, by its ability to perform efficiently month after month under exceptional production strains, has proved its worth to munition makers. It is being used by many Canadian munition plants, where it is giving absolute satisfaction.

A glance over some of the features will interest you.

Integral (en bloc) construction assures

perfect rigidity, permanent accuracy and desirable compactness.

Chucking with spring collet chuck insures accurate and speedy chucking.

Graduated feed dial, two cutting tools, and ample belt power insure output of accurate work in least possible time.

Machines are also built for 15, 18, 60-pdr. and 6" shells.

ROELOFSON MACHINE & TOOL COMPANY, LIMITED

Head Offices: 1501 Royal Bank Bldg., Toronto, Canada. Works: Galt, Canada

If any advertisement interests you, tear it out now and place with letters to be answered.

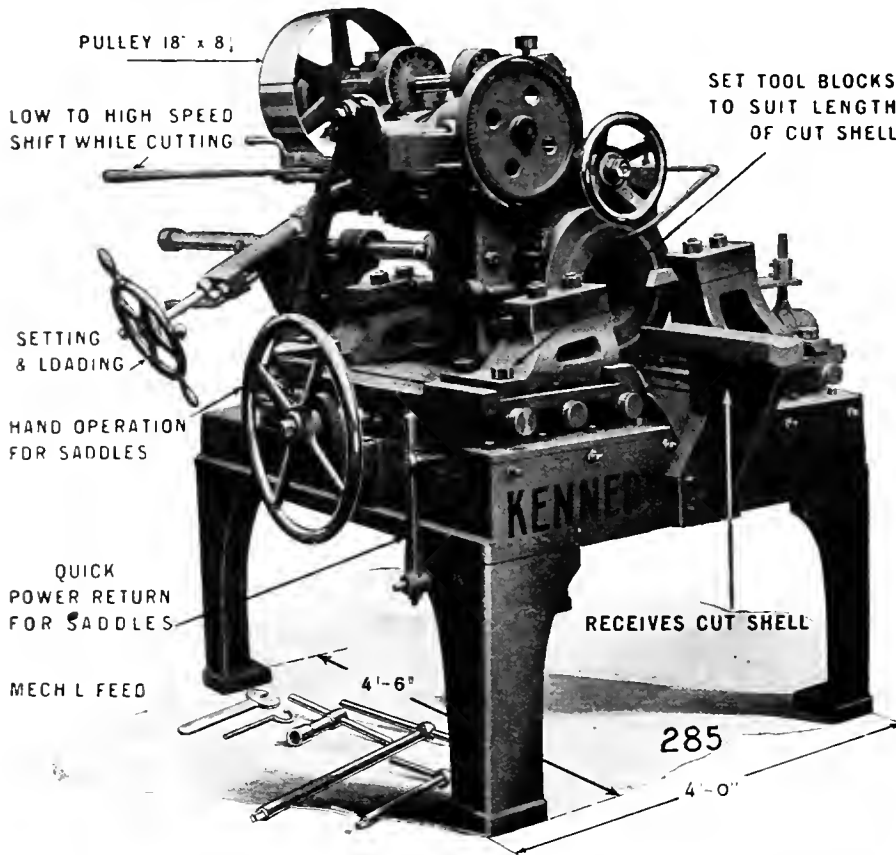

CUTTING-OFF MACHINES

Cuts both ends at once

except 8 in. and 9 in. sizes which cut one end only

Forgings load in one end and discharge out the other when cut

A Girl can operate it

New quick power return for saddles

DELIVERIES REASONABLE

The
Wm. Kennedy & Sons,
Limited
Owen Sound

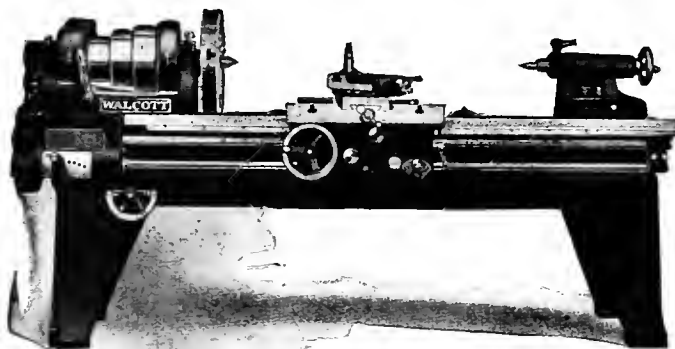

THE WALCOTT LATHE

is backed by lathe-building experience extending over 35 years

These are features of Walcott Lathes: drop-forged gears in apron; all-steel gears in gear-box; large ways on bed, all gears completely enclosed. Parts are interchangeable. Rigid headstock and tailstock.

You'll get the full story in our printed matter. Send for it surely if you are about to buy a lathe.

WALCOTT LATHE COMPANY

Successors to

Walcott & Wood Machine Tool Co., Calhoun St.,
Jackson, Michigan

The Life of a Thread Miller

Depends not upon the amount of work it does, but the ease and thoroughness with which the work is done. These Thread Millers are noted for these qualities. Its quality of work is unrivalled. Our Service Department will give you all the particulars. *Write us!*

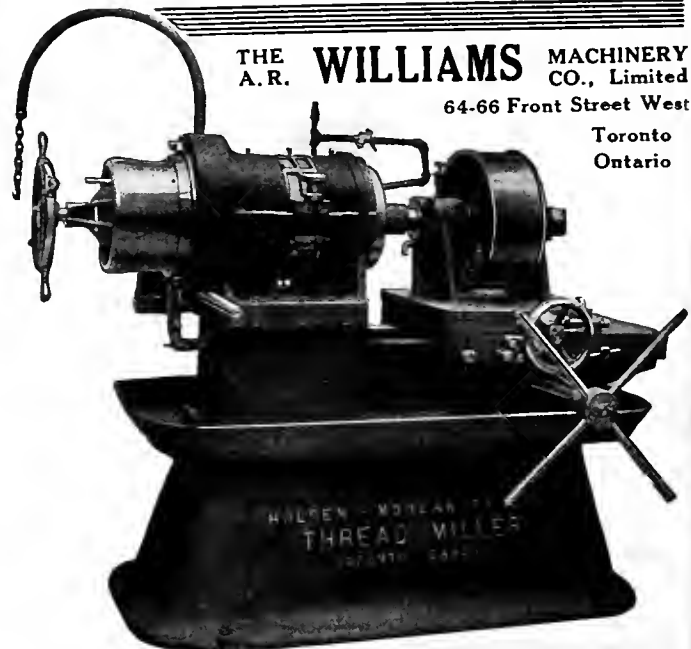

THE WILLIAMS MACHINERY CO., Limited

64-66 Front Street West

Toronto
Ontario

Mention this paper when writing advertisers. It will identify the proposition about which you require information.

Back of Every Manufactured Article is the Raw Material from which it is Made

The processes may be excellent, the workmanship superb — BUT — unless the raw material is right the finished product is defective.

The Steel from which



TRADE MARK

QUALITY FILES

is made is BEST CRUCIBLE CAST STEEL ONLY. No Open Hearth Steel is used. It is made by experts who have been specializing in File Steel for over half a century. Each run of steel has a searching chemical and physical test, which means that every bar of steel which enters into the making of P.H. Files is as near perfect as science and skill can make it.

Besides all which, P.H. Files are — “Made for Craftsmen—by Craftsmen.”

Result—FILE PERFECTION.

Port Hope File Manufacturing Company Limited - Port Hope, Ont.

ASK YOUR JOBBER

DOES IT FIT YOUR REQUIREMENTS?

A 6" Boring Lathe of exceptional strength. The strong driving gears, the convenience and speed of the tailstock and pilot wheel: these features make you stop. While stopping drop us a card for complete specifications. Our lathes comprise a very complete range. Inquire.

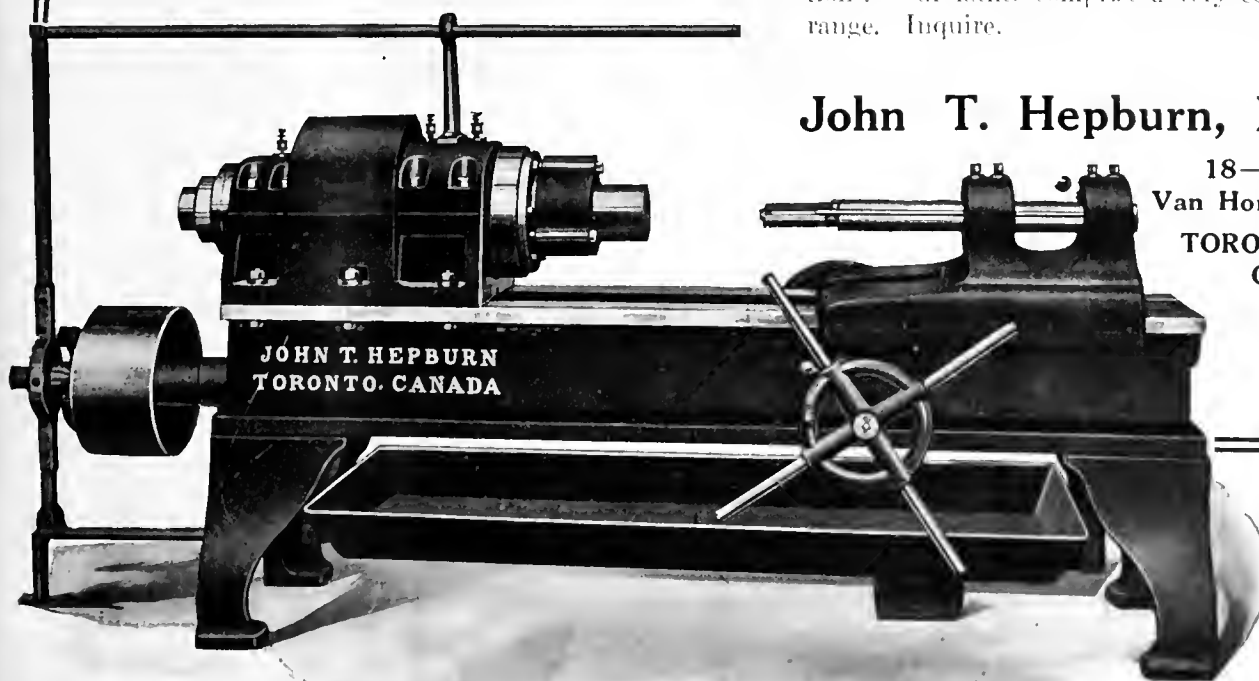

John T. Hepburn, Ltd.

18-60
Van Horne St.
TORONTO
Ontario

If any advertisement interests you, tear it out now and place with letters to be answered.

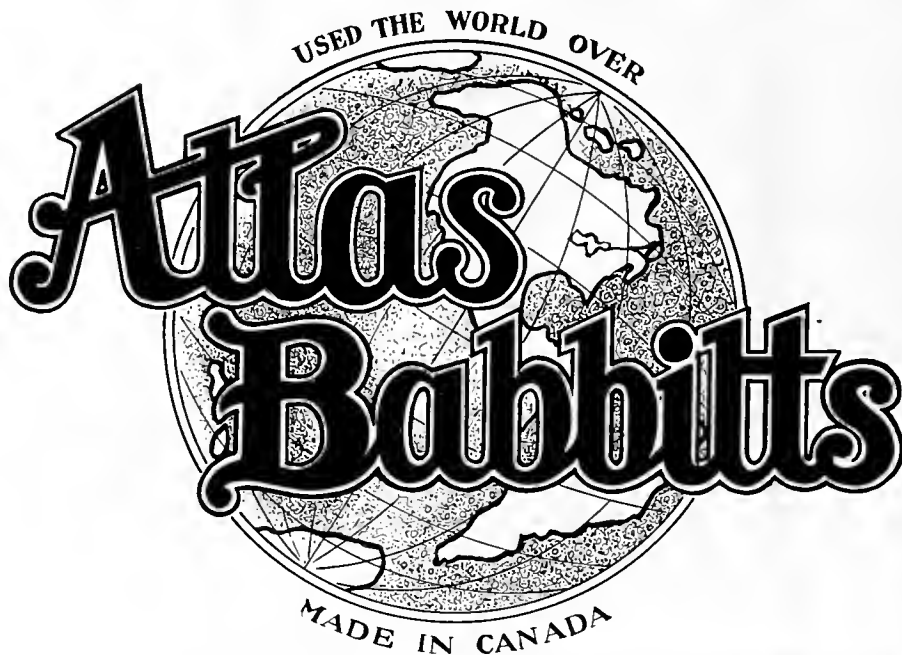
ECONOMY**UNIFORMITY**

AMACOL
 TENAXAS
 TIN TOUGHENED
 ATLAS
 MASCOT
 W. E. W. BABBITT

THIS RANGE OF
ATLAS BABBITTS
 WILL MEET ANY OF
 YOUR DEMANDS
AND **SATISFY** YOU

ATLAS METAL and ALLOYS COMPANY of CANADA, Limited
 MONTREAL

Sales Agents :

The Canadian B. K. Morton Co., Limited

MONTREAL
 49 Common Street

TORONTO
 86 Richmond Street East

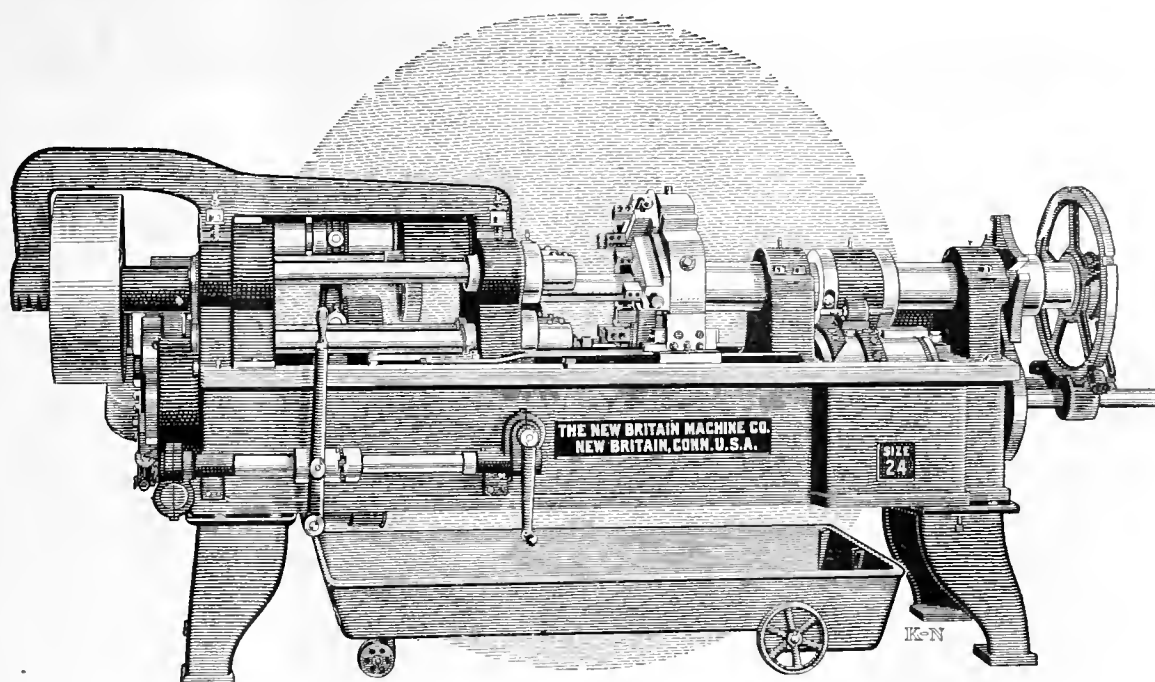

NEW BRITAIN AUTOMATICS

Is
75%
Worth
Saving?

The
NEW BRITAIN
MACHINE
COMPANY
New Britain, Conn.

TO the executive who knows that the difference between profit and loss in the conduct of his business is a matter of comparatively few per cent., such a question may appear absurd.

He is constantly seeking to reduce his costs—a little here, a little there. Each individual saving may be relatively insignificant but he realizes their aggregate will tremendously affect his balance sheet.

Yet, in spite of the apparent absurdity of this question, many manufacturers are daily suffering this loss through inefficient methods of machining castings, forgings, and second-operation screw machine work. In the "New Britain" Multiple-Spindle Automatic Chucking Machine the entire series of operations is completed in the time of a single operation, all tools cutting simultaneously.

The resulting productions are three to five times larger than those obtainable on other machines.

A skilled mechanic is not required for their successful operation—a consideration of prime importance under the present condition of the labor market.

May we submit an estimate of savings that might be effected on your chuck work? Send blue prints.

If any advertisement interests you, tear it out now and place with letters to be answered.

260 Railroad Shops Employ the Landis Die

One hundred and thirty Railroad Companies have purchased Landis Bolt Cutters and Pipe-Threading Machines, and are using them in two hundred and sixty railroad shops.

That is a significant statement. It means that the **Landis Die** is becoming the **standard thread-cutting tool** in shops where efficiency is the keynote and where the machines must be sufficiently rigid and powerful to withstand hard service.

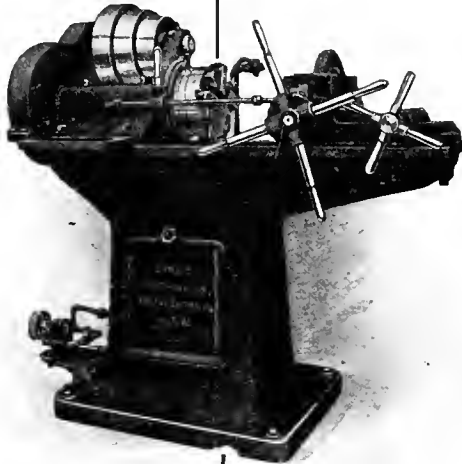

Landis Die Heads and Machines are chosen because the **chaser has a life, twenty times that of any other die**; because it can be ground at the cutting end only and never requires annealing, hobbing or retempering. Other features are, the **interchangeability of the chasers, high cutting speed, right and left hand threading with the same set of chasers** by grinding both cutting ends and using right and left hand chaser holders, etc.

The Landis Die is the very tool for your threading requirements.

Write to-day for particulars.

Landis Machine Company
Waynesboro, Pa.

Two Cuts Simultaneously

One up, the other down. This is what makes the **Hurlbut-Rogers Cutting-Off and Centering Machine** virtually double the output and reduce the cost per piece about one-half.

The Hurlbut-Rogers Machine gives you capacity of two machines at the expense and in the floor space of one machine.

We build them for hard work and the utmost in accuracy—and their **GREAT SUCCESS ON SHELLS** shows it.

Let us go into details.

HURLBUT-ROGERS MACHINERY CO., South Sudbury, Mass.

FOREIGN AGENTS—England, Chas. Churchill & Co., Ltd., London, Manchester, Glasgow and Newcastle-on-Tyne. H. W. PETRIE, TORONTO, CANADA.

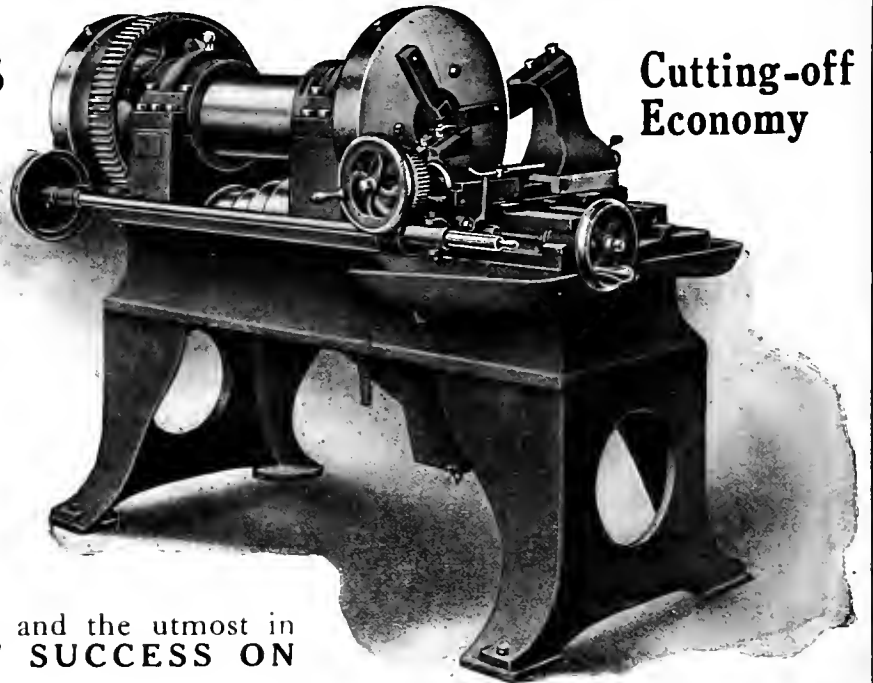

**Cutting-off
Economy**

5-inch Cone-Driven Machine

THE New McKenzie 15-inch shaper owes its origin to a long-felt want for a machine of its capabilities. It has been installed in many shops now and is "filling the bill" in every detail.

All bearings and sliding surfaces are hand scraped to surface plates and are fitted with adjustments for taking up wear. All feeds have graduated collars. Changes of feed and position of ram are made from working side.

Column is sturdy and well braced. Cross-rail and table are of proper proportions with large bearing surface. There are a dozen and one other features, too. Write for full details. They will prove interesting.

Have us send you a description of our leading lines.

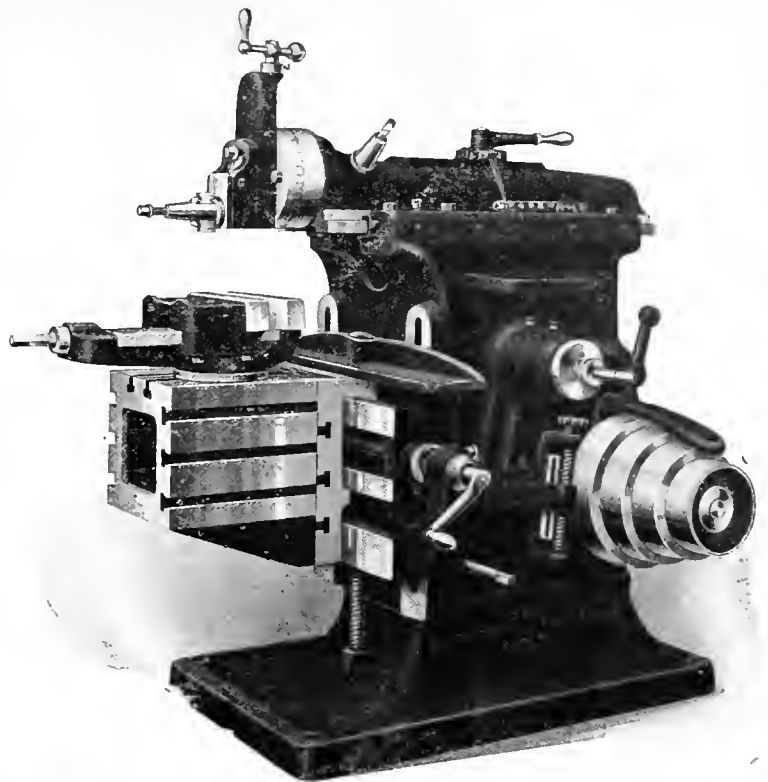

The D. McKenzie Machinery Company
GUELPH, ONTARIO

HALL

Pipe Threading Machinery and Shell Cutting-off Machines

This illustration shows the new No. 8 Hall Gear Box Driven Pipe Lathe. Regular Capacity 2½" to 8" inclusive.

The last word in Pipe Machine Construction.

Let us give you full particulars of this machine which is only one of a large number having capacity ½" to 18" pipe.

Write us for catalog and prices on:

Pipe Threading Machines
Nipple Threading Machines
Roller Pipe Cutters

or

Cutting-off Machine for shells or bar stock.
Any capacity ½" to 18".

JOHN H. HALL & SONS, LIMITED
BRANTFORD ∴ CANADA

EUROPEAN AGENTS:
Universal Machinery Corporation, Limited, London

*Made
in Canada*

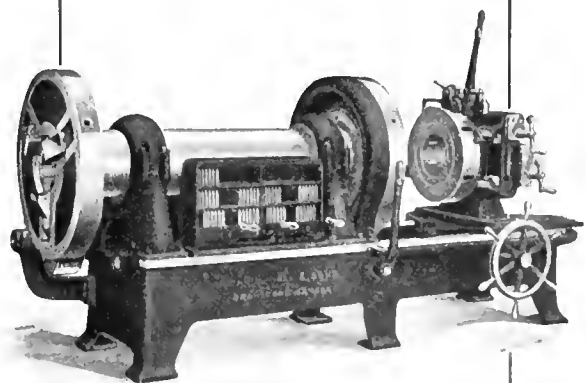

*Capacity
2½" to 8"
inclusive*

If any advertisement interests you, tear it out now and place with letters to be answered.

*Telegraph your
order at our
expense
Don't
Wait*

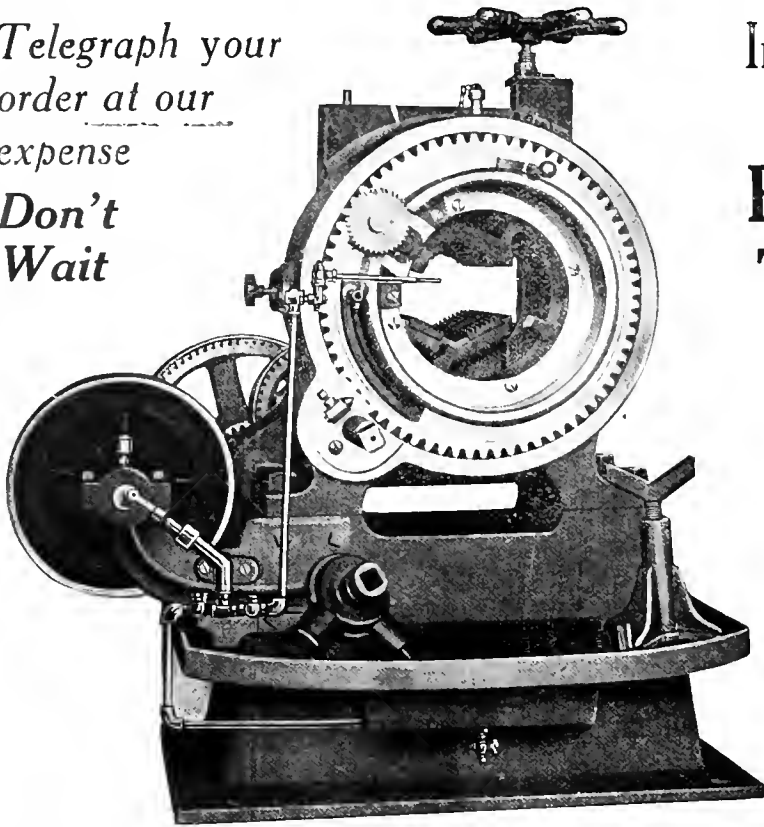

In These WAR Times If you have need of a **Pipe Cutting and Threading Machine**

You want to know three
things and in this order:

Delivery

All sizes up to 15", for either Hand, Belt or Electric drive, kept in stock for immediate shipment. No waiting.

Quality

The original FORBES. Our specialty since 1882. More than 25,000 in use.

Price

Less than any other Standard Machine on the market, and less than half of many. Our system is the reason.

THE CURTIS & CURTIS CO., 115 Garden Street, Bridgeport, Conn.

A Hunter "Duplex" on Shrapnel Stock

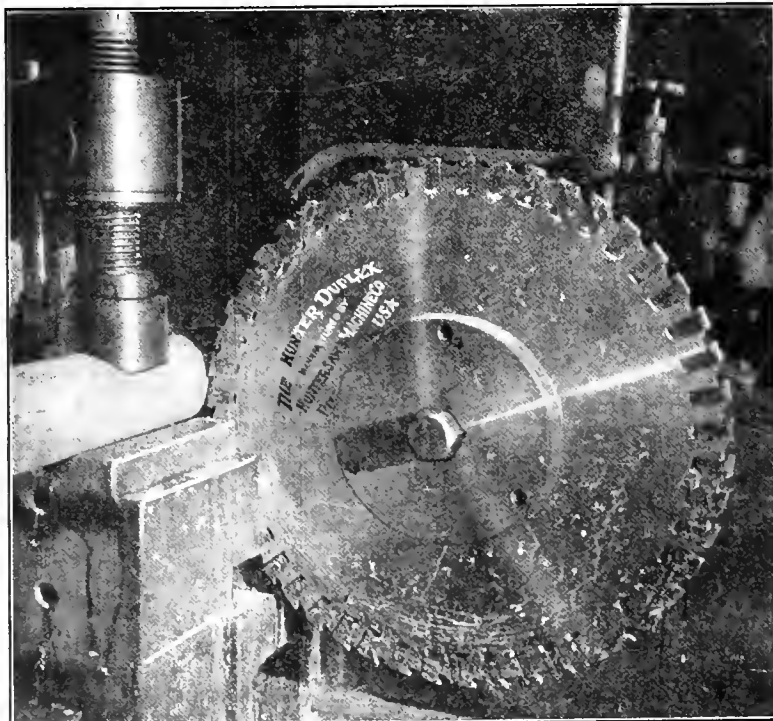

FAST GOING on Newton Machine

Through 3½" round 60
Carbon, 70 Manganese
Shrapnel Stock every

2 MINUTES

The secret of Hunter
"Duplex" Saw speed is
the method of holding the
high speed teeth.

You can use this speed
profitably—on shapnel or
any other stock.

*Let us send full
Particulars.*

HUNTER SAW & MACHINE COMPANY, Pittsburg, Pa.



**The Reason
For So Many Repeat Orders**

after comparative tests is that no magnifying glass is necessary to distinguish the increased production and the better class of work on the PEERLESS High-Speed Cutting-off Saw.

A third order just came in from one of the largest concerns in the United States, and is it not a fact after a firm has standardized on a certain make of tool that some real results must be produced in order to effect a change?

One of our customers writes: "It takes us only 1-15th of the time to cut our stock on the PEERLESS that it did on our other machine."

If you are open to conviction we have a proposition to offer that no manufacturer can afford to pass up.

PEERLESS MACHINE CO. 1607 Racine St.
RACINE, WIS., U.S.A.

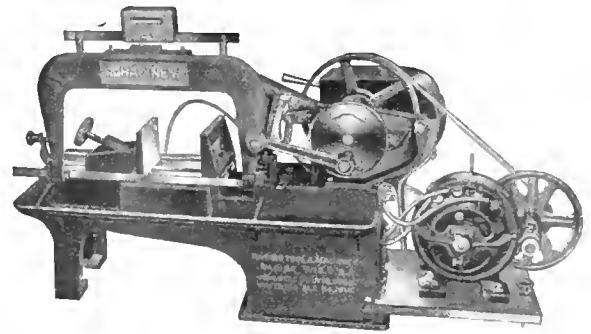

**We will send a Racine on
a Trial Basis—Why?**

The Racine machine is the only high-speed metal-cutting machine in the world that is absolutely positive in every action, and will duplicate itself in every cut during the entire life of the machine. All wearing parts are adjustable and accurately machined.

Racine Tool & Machine Co.
15 Melbourne Ave., Racine, Wis., U.S.A.

IN STOCK—FOR IMMEDIATE SHIPMENT

SUBJECT TO PRIOR SALE

H.E.W. Boring Lathes To Handle Shells Up To 6"

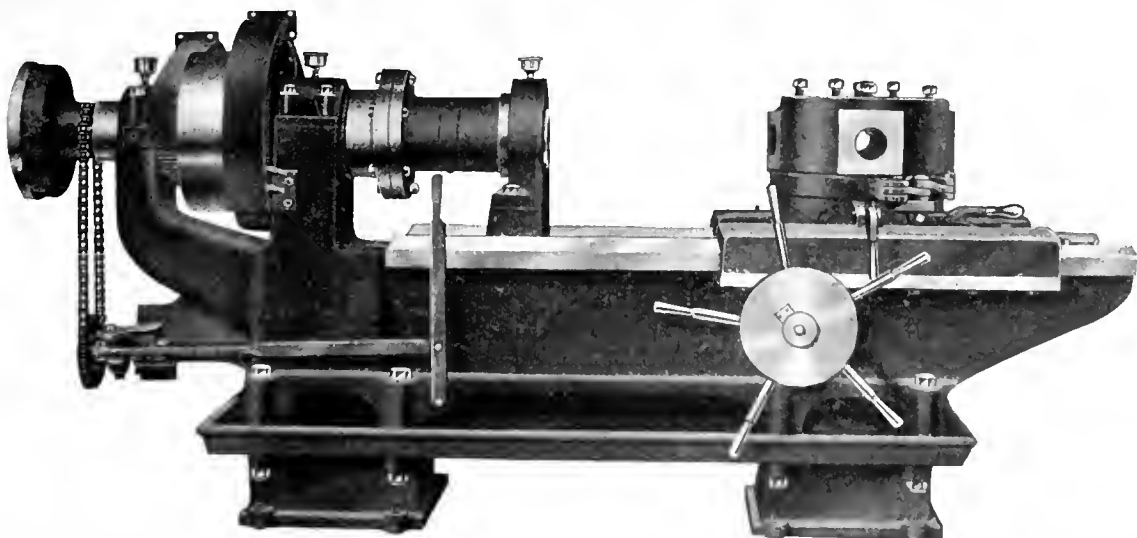

MADE IN CANADA

SPECIFICATIONS ON REQUEST

HYDE ENGINEERING WORKS

CONSULTING AND MANUFACTURING ENGINEERS

P.O. Box 1185

27 William Street, MONTREAL, P.Q.

If any advertisement interests you, tear it out now and place with letters to be answered.

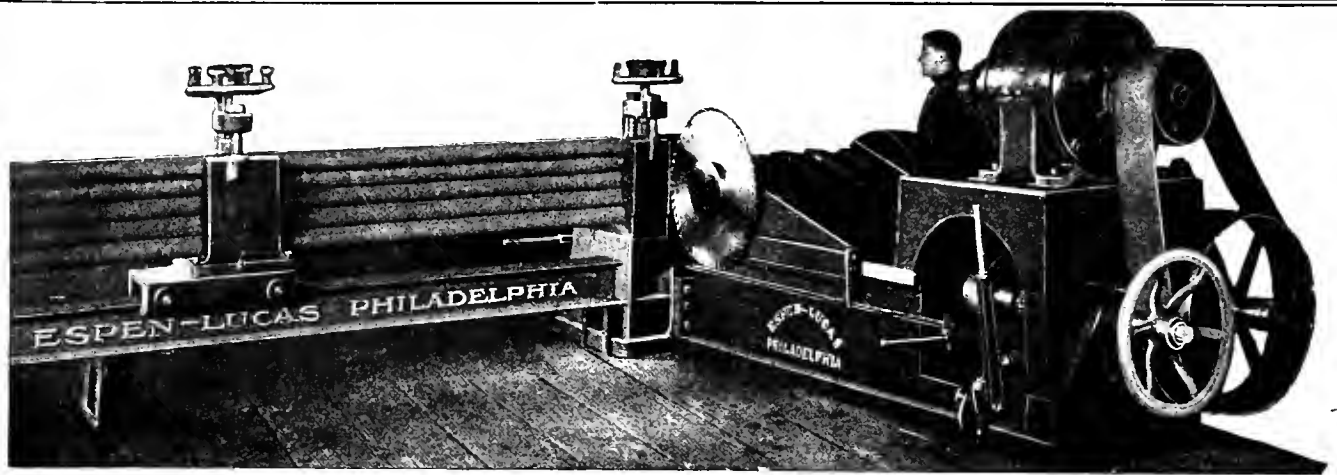

Used by all Large Shrapnel Manufacturers.

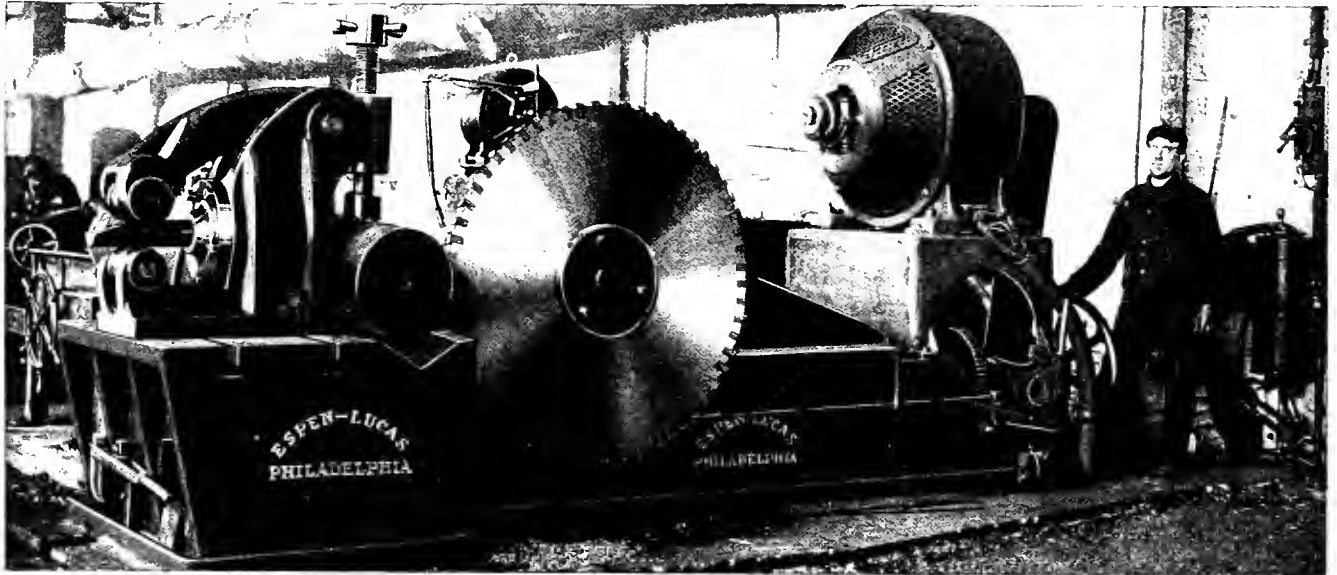

Nova Scotia Steel and Coal Co.

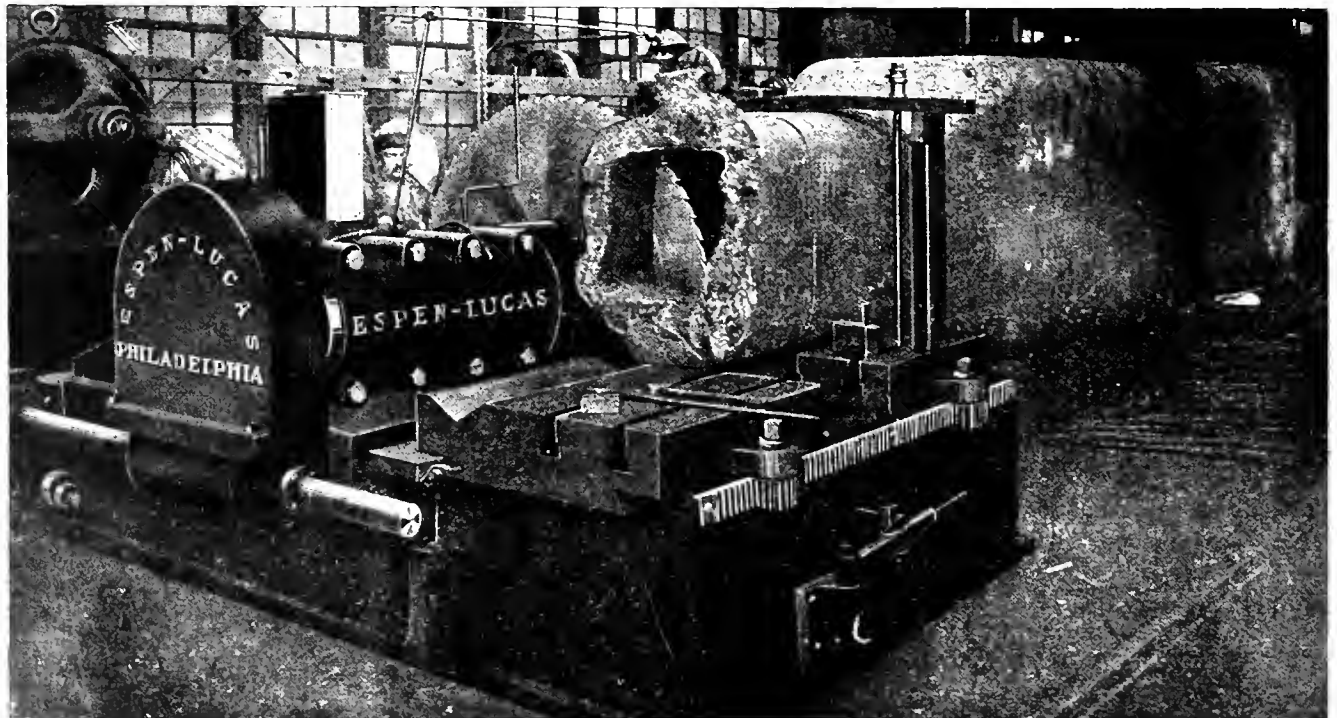

Penna. Steel Co.

THE ESPEN-LUCAS MACHINE WORKS, FRONT & GIRARD AVENUE,
 PHILADELPHIA, PENNA., U.S.A.

“STERLING”

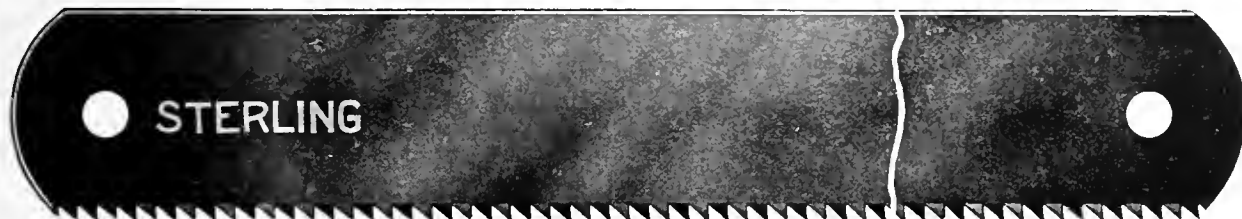

The man who knows, says this brand of Hack Saw Blade is good—he believes there are none better. The hand blades in all pitches are the best that can be made, also for power machines, they cut true, cut fast and last long. They give real value used in any first-class machine.

A combination of this blade with a “STERLING” No. 5 High Duty Power Hack Saw Machine is a real winner, and for cutting shell and shrapnel material has no superior.

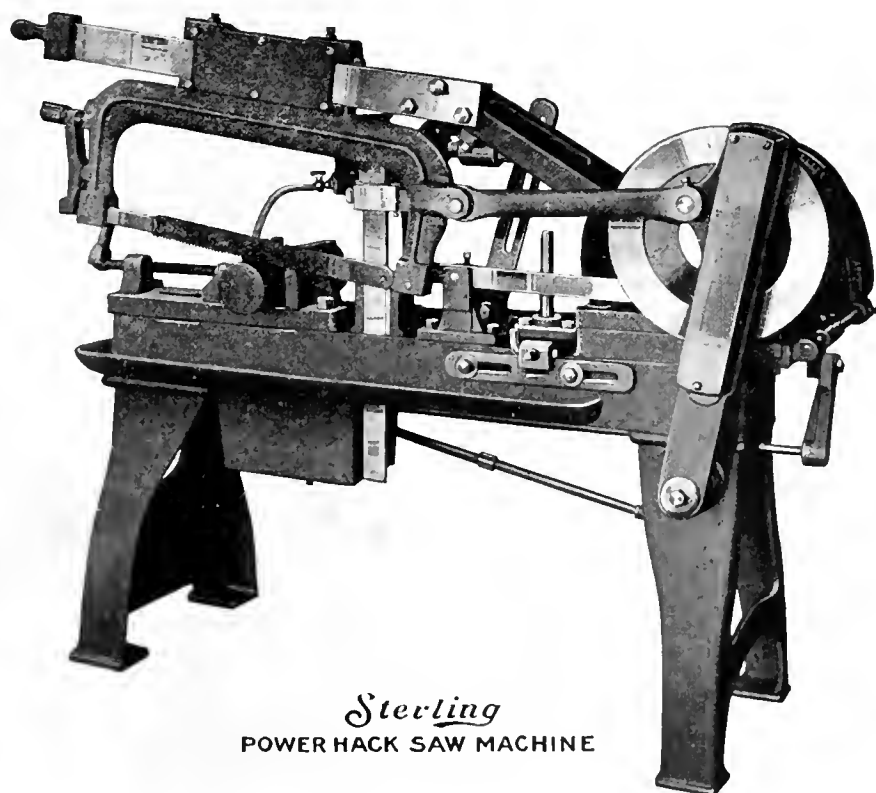

Sterling
POWER HACK SAW MACHINE

Manufactured by

DIAMOND SAW & STAMPING WORKS

357 SEVENTH STREET

BUFFALO, N. Y., U. S. A.

If any advertisement interests you, tear it out now and place with letters to be answered.

FUSE HOLE GAUGES

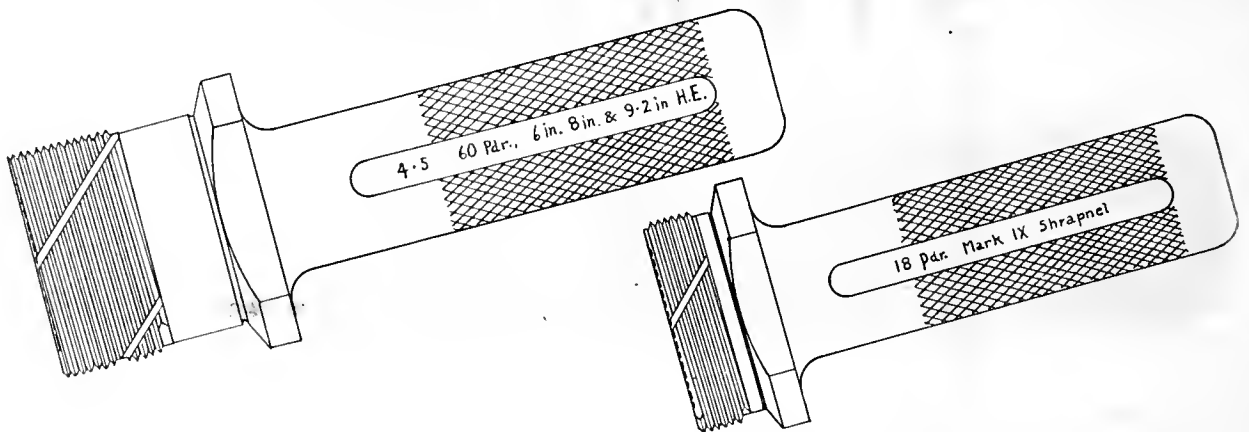

Manufacturing and inspection fuse hole gauges for all size shells. A surplus stock enables us to ship immediately.

Windsor Machine & Tool Works

Windsor, Ontario

If it is a Question of Efficiency

There are lathes that will give you all grades of efficiency. But we interpret efficiency to mean highest speed and quality of production together with lowest possible cost. These features are embodied in the making and with them are associated a range of work that registers from coarse to the very finest. Investigate. If this doesn't meet your requirements we have such a line that we can easily supply your wants.

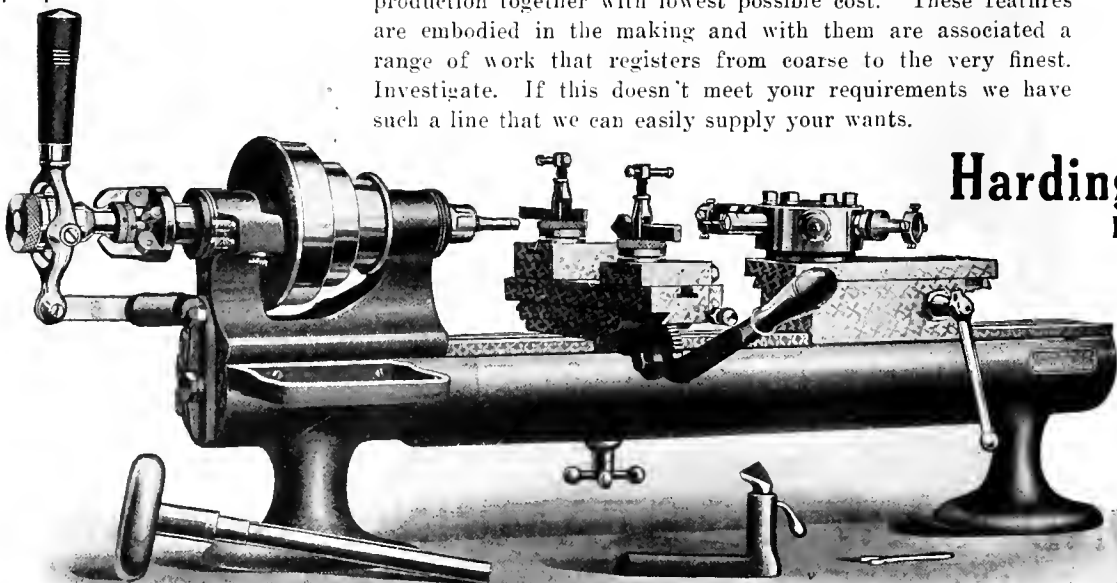

Hardinge Bros
Inc.

1770 Berteau
Avenue,
CHICAGO,
ILL., U.S.A.



Here the artist has depicted VICTORY about to welcome and crown the brave legions returning from overseas. Notice that the figure is a companion of Industry which in this case is represented by the maker of munitions.

A limited number of copies, suitable for framing and free from advertising, will be mailed without charge upon request to the makers of Red Cut Superior the Nationally Known First Quality Quick Speed Steel.



Red Cut Superior

The Nationally Known First Quality
HIGH SPEED STEEL

PROCLAIMED

By the Men Who Use It

**THE BEST FOR ALL
MACHINE WORK**

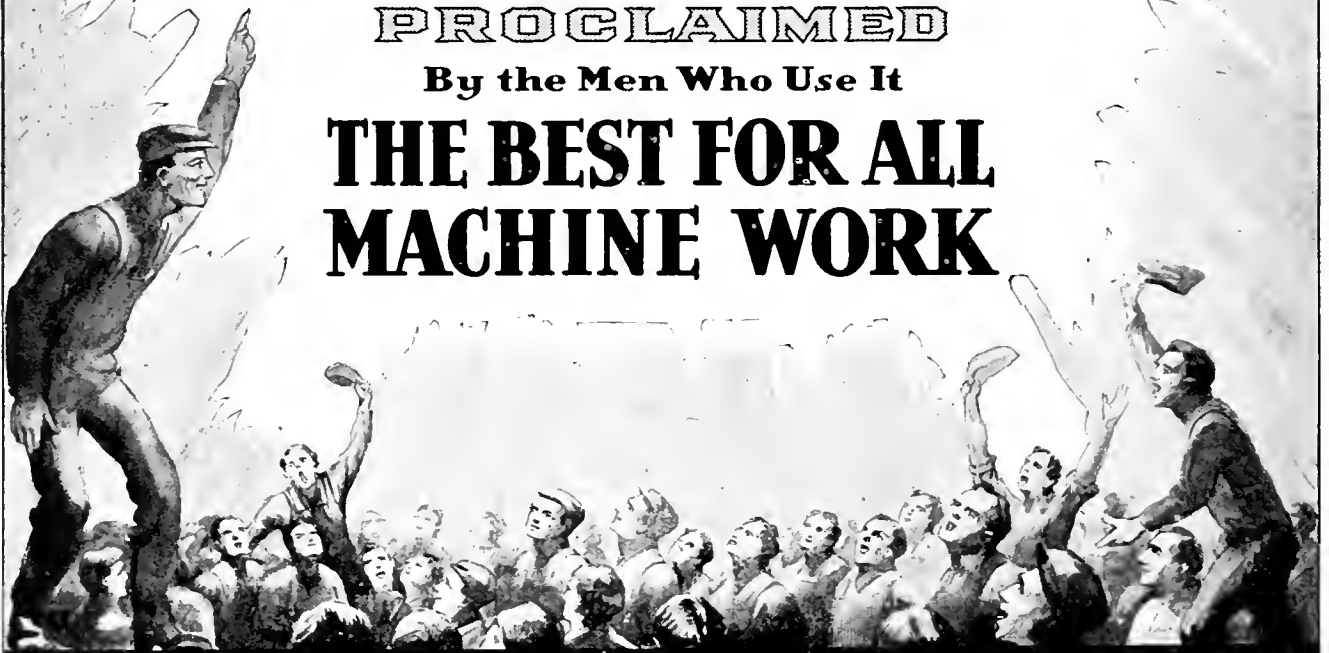

VANADIUM-ALLOYS STEEL CO.
PITTSBURGH, PA. WORKS AT LATROBE, PA.

Carried in Stock in These Warehouses:
 E.T. WARD'S SONS 44 Farnsworth St. BOSTON, Mass.
 GEO. NASH CO. 304 Hudson St. NEW YORK N.Y.
 FIELD & CO. Inc. 721 Arch St. PHILADELPHIA, Pa.
 VANADIUM-ALLOYS STEEL CO. PITTSBURGH, Pa. & LATROBE, Pa.
 GEO. NASH CO. 646 Washington Blvd. CHICAGO, Ill.

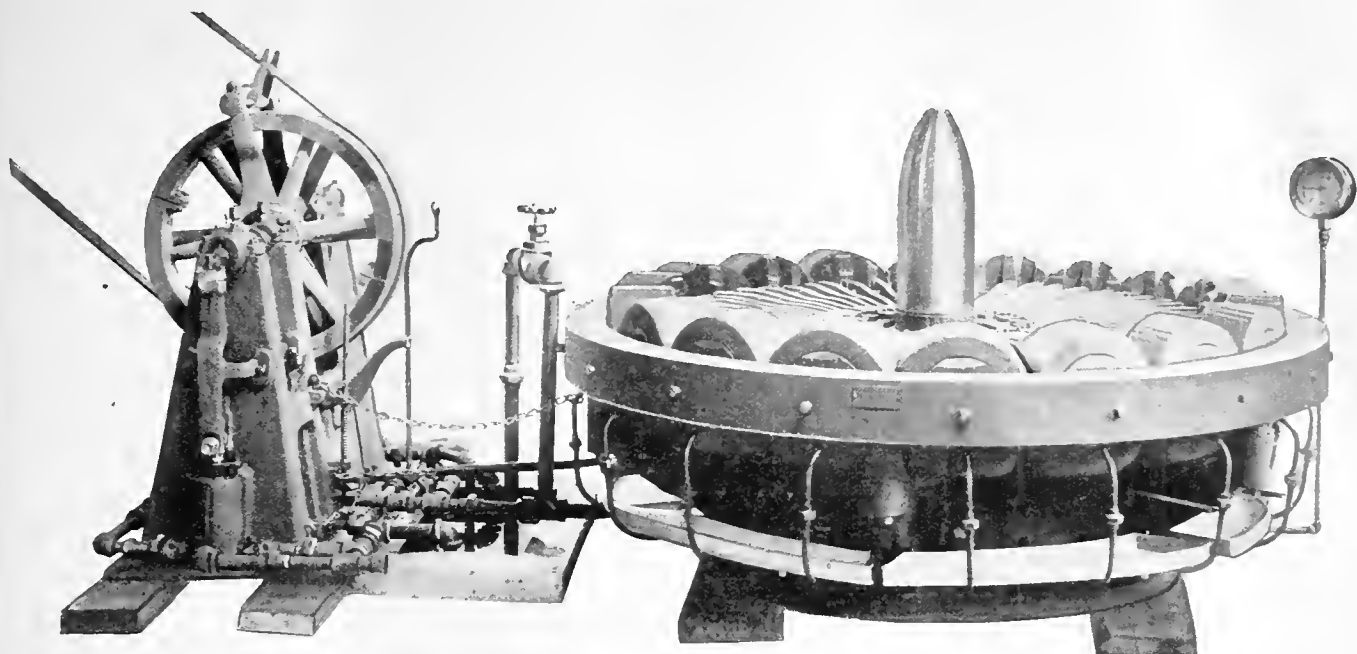

The New "West" Banding Press

for

Shells up to 12 inches

Built in smaller sizes for 18 pdr., 4.5 in. and 6 in. Howitzer

6 to 18 Cylinders; Ample Power, Ample Strength; Reasonable Price; no accumulator required. Our line of presses is very complete, consisting of five regular sizes from 3" up to 12" or 15" diameter.

Very many of our presses are now in use by large contractors in both Canada and the United States, giving satisfactory results, and turning out work that meets government requirements.

Write or wire for prices. Please specify size of shells and dimensions of bands.

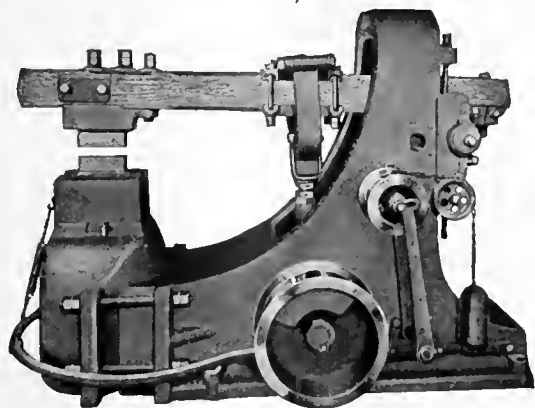

Rochester Helve Hammer

A well-built, substantial tool for welding and general forging. Made in six sizes, 25 lb. to 100 lb. heads, and two styles of frame.

Send for catalogue and give us information regarding character of your work.

The West Tire Setter Co.

ROCHESTER, N.Y. U.S.A.

If any advertisement interests you, tear it out now and place with letters to be answered.

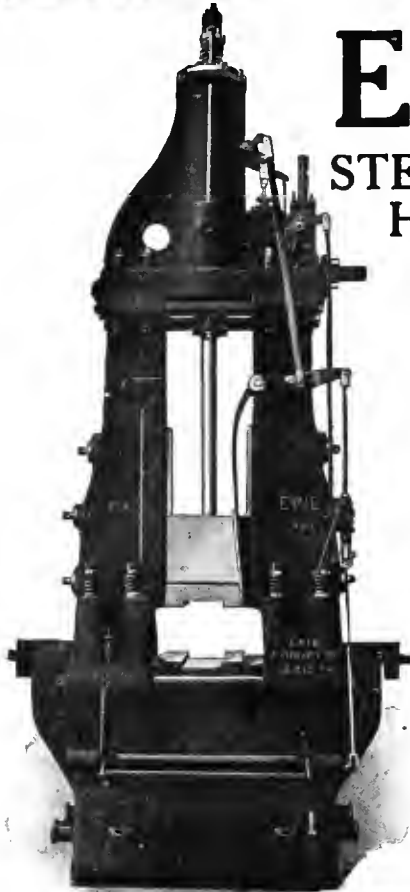

ERIE STEAM DROP HAMMER

Powerful! Massive!
Built for a wide range of big work. A leader in its class. Any desired force or rapidity of blows may be obtained; or movement may be automatic for continuous strokes. Automatic safety is a big feature of the "ERIE."

We also build Trimming Presses, Single and Double Frame Steam Forging Hammers and Tool Dressing Hammers.

Erie Foundry Co.
ERIE, PA.
U.S.A.

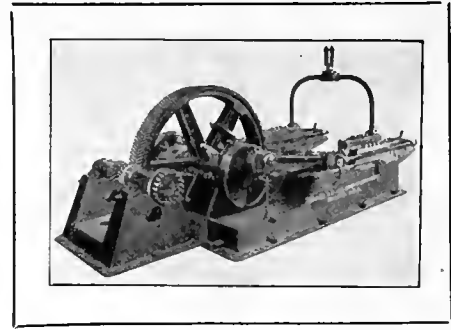

ELMES

18" Stroke Hydraulic Pump

for maximum pressures and capacities, for 250 horse-power motor—a pump designed to meet the demand for a high-pressure outfit of large capacity, and one able to withstand the severe usage of present-day practice.

Other designs for all pressures and capacities.

Charles F. Elmes Engineering Works

217 No. Morgan Street

CHICAGO, ILL.



Rivet Speed

One every second is a speed which this Grant Rivet machine will keep up indefinitely, in any degree of tightness or looseness desired. Each rivet is finished with perfectly shaped head, polished and with no hammer marks showing.

We claim this is the only machine manufactured that will accomplish this feat. Our claims are unchallenged. By writing for our catalogues you may obtain full information regarding the ability of this machine.

We are rivet machine specialists. Get in touch with us.

The Grant Mfg. & Machine Co.
Holland Ave., Bridgeport, Conn., U.S.A.

HIGH SPEED HAMMERS

For High Speed Work

FEATURES:

Economy in floor space, elimination of weight and a guaranteed saving of from 15% to 20% on any class of work. The life of the machine is practically indefinite as phosphor bronze bushings are used throughout.

No riveting too intricate for us; no riveting which our machine cannot accomplish.

Send for our High Speed Hammer Book.

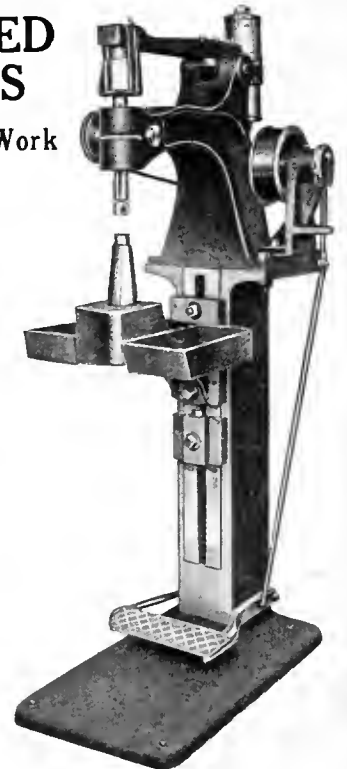

THE HIGH SPEED HAMMER CO.
Rochester, N.Y.

Sales Agents: The A. R. Williams Machinery Company, Limited, Toronto, Ontario.

The "TOLEDO" OPEN BACK PRESSES

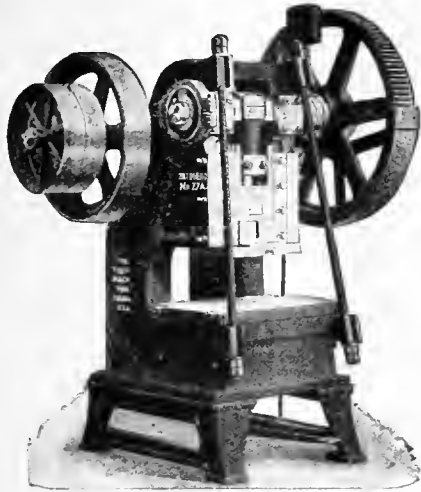

Their Quality and value recognized and performance proved in every country.

Many new features and improvements added to the rugged, sturdy construction specially adapt them to punching, shearing, perforating, bending and forming operations, to trimming drop forgings, etc.

Furnished on inclined legs with long stroke for trimming and finishing deep-stamped shells, enameled ware and similar work.

A "TOLEDO" FOR EVERY PRESS AND DIE NEED.

The Toledo Machine & Tool Co.
Toledo, Ohio

A Combination of Rigidity, Accuracy, Simplicity and Ease of Operation



Bodies are inclinable and convenient for handling dies and material. Slides are long and well gibbed.



Inclinable Power Presses

reduce the maintenance cost of both machine and tools.

BUILT IN EIGHTEEN SIZES.

Adapted for many operations in the manufacture of tin cans, pieced tinware, metal packages, brass goods, electrical goods, trimmings, etc. *Catalog 2-G, describing them, sent on request.*

E. W. Bliss Co., 20 Adams Street, Brooklyn, N.Y. U.S.A.

Chicago Office: Peoples' Gas Bldg.; Detroit Office: Dime Bank Bldg.; Cleveland Office: Union Bank Bldg. Offices in Europe: 100 Boulevard Victor Hugo, St. Ouen, Paris; Pockock St., Blackfriars Rd., London, S.E.

Triple Purpose

"METALWOOD" COMBINATION

Forcing, Broaching and Straightening Press.

Its value is in the many uses to which it is adaptable. Auxiliary tables and fixtures add greatly to its usefulness. It is not "encumbered" with a single excess part. Built for production.

**Metalwood
Mfg. Co.**

Leib & Wight Sts.,
DETROIT, MICH.
U.S.A.

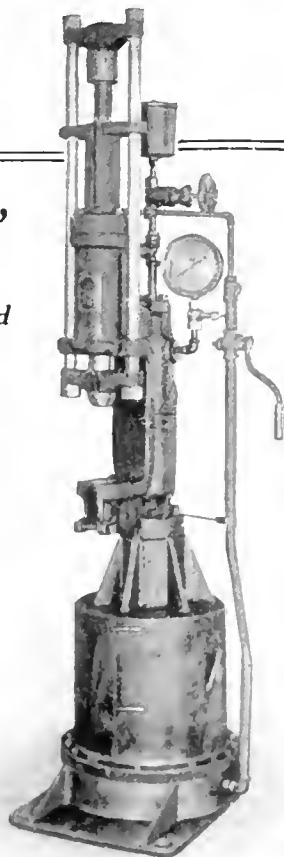

PRESSES

Pumps
and
Accumulators

FOR ALL
PURPOSES

Made in
Canada

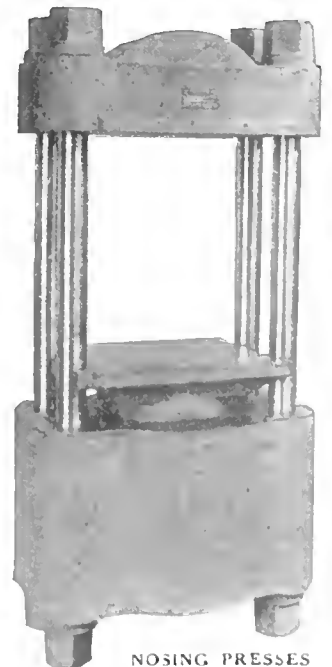

NOSING PRESSES

WILLIAM R. PERRIN, Limited
TORONTO

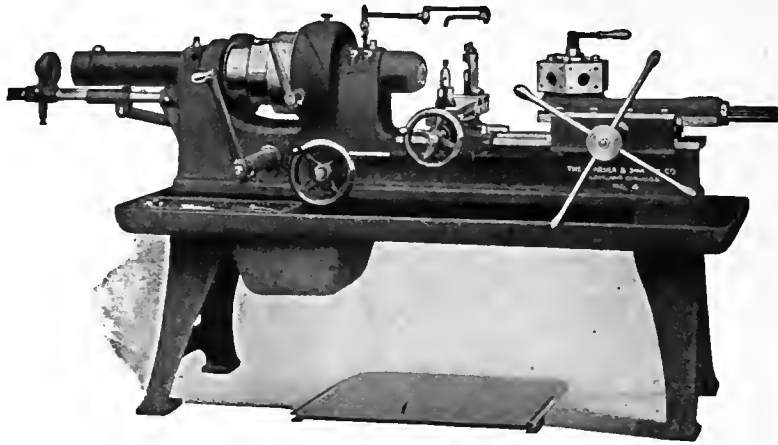

No. 4 Turret Screw Machine

TRUE ECONOMY

In these times, when labor and materials cost so much, and when it is a patriotic duty to speed up production, you can't afford to use slow, inaccurate machines. It is true economy to use the

Warner & Swasey Turret Screw Machines

They are large producers. They have the strength, the power and the conveniences to speed production to the limit.

And they are accurate. Rigidity is assured not only in the machines themselves, but also in the tools, which are strong and firmly supported.

The Universal Hollow-Hexagon Turret Lathes and the No. 4 Universal Turret Screw Machine take two cuts at one time. By means of separate feed shafts for carriage and turret saddle they face, undercut or form with the carriage while boring or turning with the hexagon turret.

Write for Descriptive Literature

THE WARNER & SWASEY COMPANY

TURRET LATHES—TURRET SCREW MACHINES—BRASS WORKING MACHINE TOOLS

CLEVELAND, OHIO, U.S.A.

Canadian Agents: A. R. Williams Machinery Co., Limited, Toronto, St. John, Winnipeg and Vancouver.
Williams & Wilson, Limited, Montreal.

English Agents: Charles Churchill & Co., Limited, London, Birmingham, Manchester, Newcastle-on-Tyne, Glasgow.
Australian Agents: Beason Brothers, Sydney and Melbourne; A. Asher Smith, Sydney.

The Second Belt Drive

Reduces Noise and Gear Chatter

To the man used to rumbling gears and shrieking belts, inseparable from the operation of old-style planers, the smooth-running, silent operation of Whitcomb-Blaisdell Planers is a revelation. The Second Belt Drive, an exclusive patented feature, is responsible for the difference. It eliminates the extended train of fast running gears which wear quickly, run noisily and waste power. The accompanying "phantom" illustration shows the arrangement of this drive. Note its extreme simplicity—only a single pair of gears are used in transmitting the power. Full driving efficiency is always available just where it is needed—at the table.

We have a new catalogue, just off the press. It contains some planer points of vital interest to the man looking for better results in planing.

Send for your Copy

**WHITCOMB-BLAISDELL
MACHINE TOOL COMPANY**

WORCESTER,

MASS.



WHITCOMB- BLAISDELL PLANERS

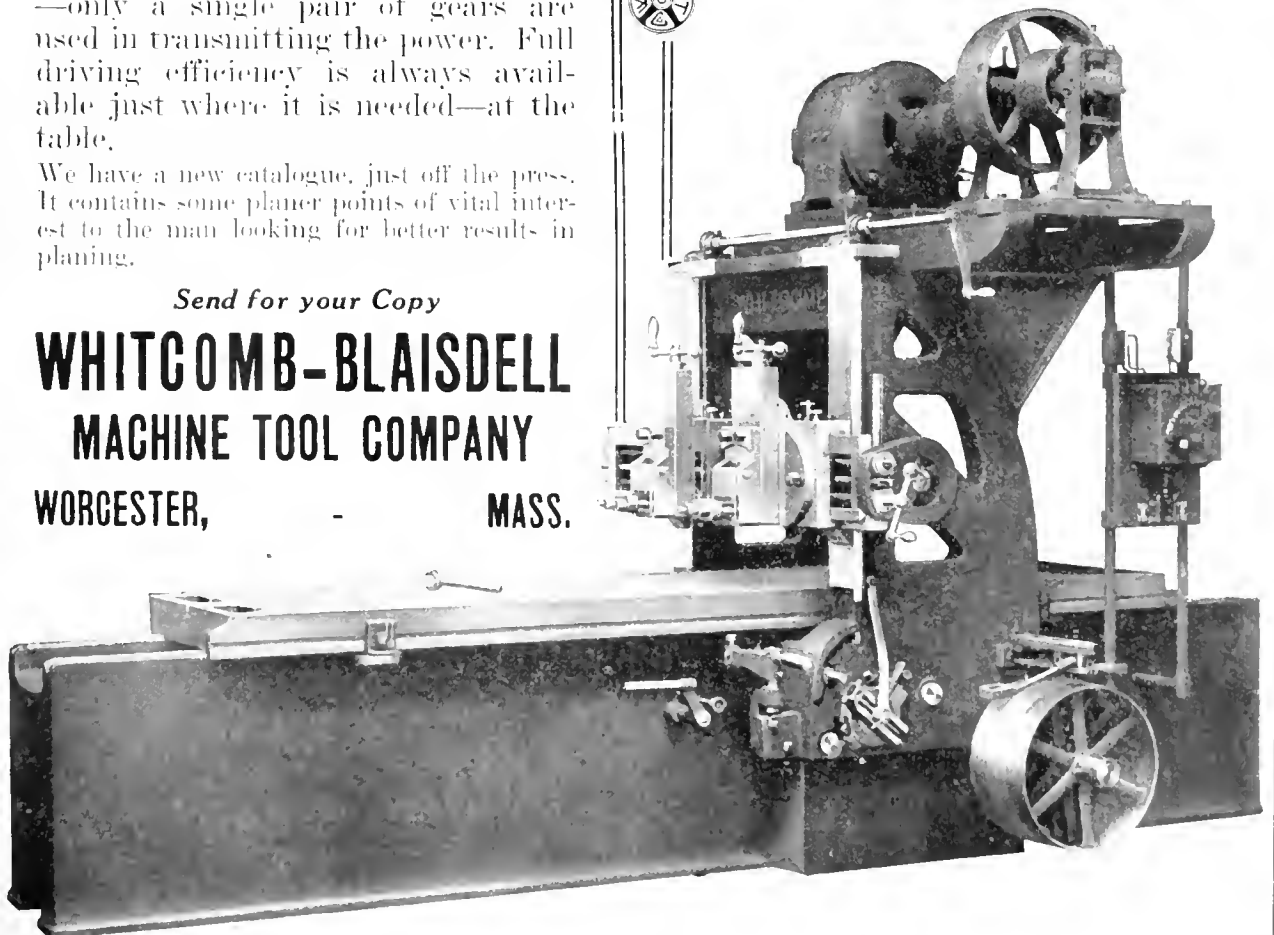

If any advertisement interests you, tear it out now and place with letters to be answered.

Established 1855

EVERYTHING IN SHEET METALS
TINPLATES
BLACK and GALVANIZED SHEETS

INGOT METALS—ANTIMONY,
COPPER, LEAD, TIN, SPELTER

Write for Monthly Stock List

M. & L. SAMUEL, BENJAMIN & CO.
KING STREET AND SPADINA AVENUE
TORONTO



Wire Cloth
of every description



We make Machinery Guards of all kinds.
Metal Lockers for Clothes
Steel Shelving for all purposes.
Drop a line for full details.
CANADA WIRE & IRON GOODS CO.
HAMILTON, ONTARIO
Eastern Representatives:
H. E. Bull, 184 Mance St.
Montreal, P.Q.



**Smooth-On
Iron Cement
No. 1**

will stop steel or water leaks in castings, boilers, pipes, etc.
Our new 144-page instruction book is free. It illustrates by photographs of actual repairs how thousands of dollars have been saved with Smooth-On. Send for your copy now.

SMOOTH-ON MFG. CO.
570-574 Communipaw Avenue
JERSEY CITY, N.J.
For Sale by Supply Houses

Mention this paper when writing advertisers. It will identify the proposition about which you require information.

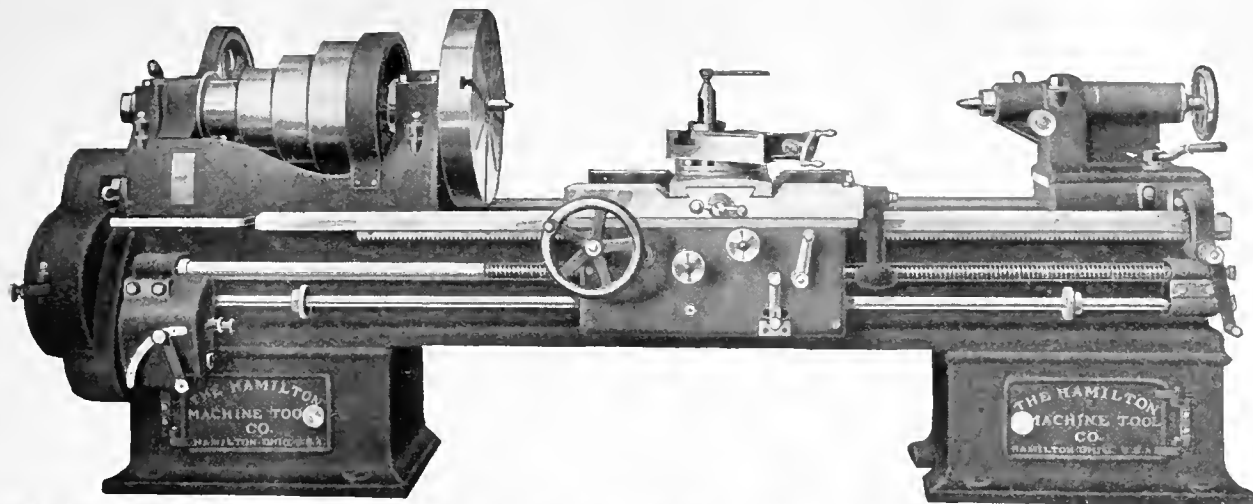

Hamilton Lathes

Is Your Cost of Production too high?

In the well-managed factory there is no greater loss of time—and therefore of money—than that resulting from the use of old style machinery.

All over the country shops are now running at top speed, and producing more for the dollar than ever before. Why? Because they are installing modern machine tools—tools built to withstand all the strain put upon them by the use of high speed tool steel.

You cannot expect to meet the competition of to-day with the methods of yesterday. To-day your equipment must be of the best, otherwise your costs will go up as your production goes down.

Investigate "HAMILTON" Lathes, put them in your factory—then watch the balance swing the other way. Speed, durability and accuracy are the points that make "HAMILTON" tools indispensable in cutting your cost of production.



For 25 Years Makers of fine Machine Tools

The Hamilton Machine Tool Co.

HAMILTON, OHIO

Sole Agents for Ontario:

H. W. Petrie, Ltd., Toronto, Ont.

Gear Service

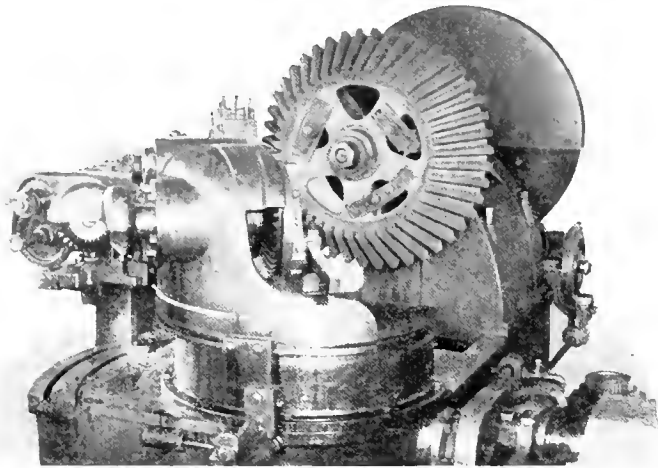

Planing teeth of large Bevel on 60-in. Gleason

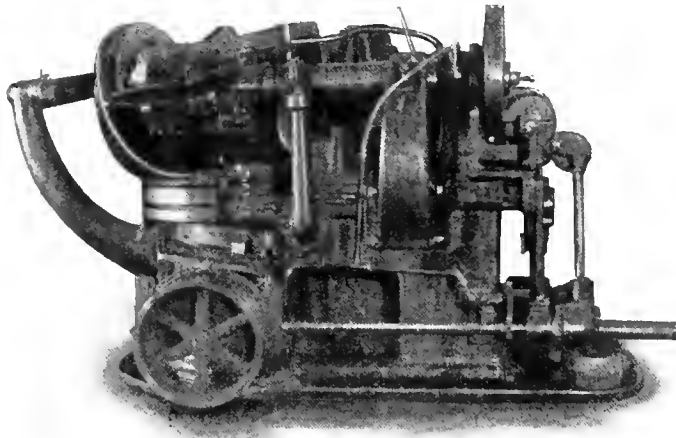

Gleason Bevel Gear Generator

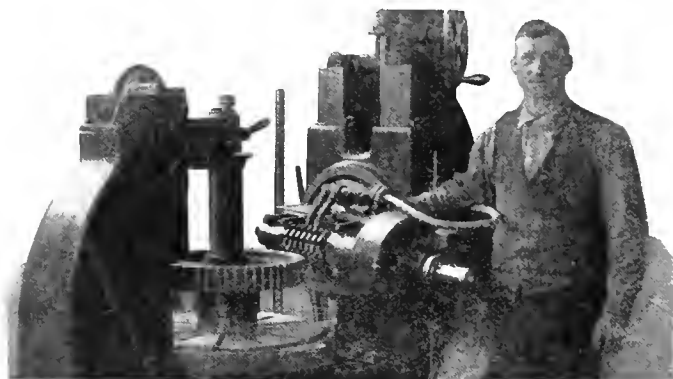

54-in. Hobber for Spur, Helical or Worm Gears

We have
a complete
and balanced
shop equipment
manned by
a force of
gear specialists
for economical
production of
cut gears

Chester B. Hamilton Jr.

B.A.Sc., Mem. Am. Soc. Mec. Eng.

The Hamilton Gear & Machine Co.
Van Horne Street, TORONTO

Mention this paper when writing advertisers. It will identify the proposition about which you require information.



Cut Gears

This Plant
is for
Your Service

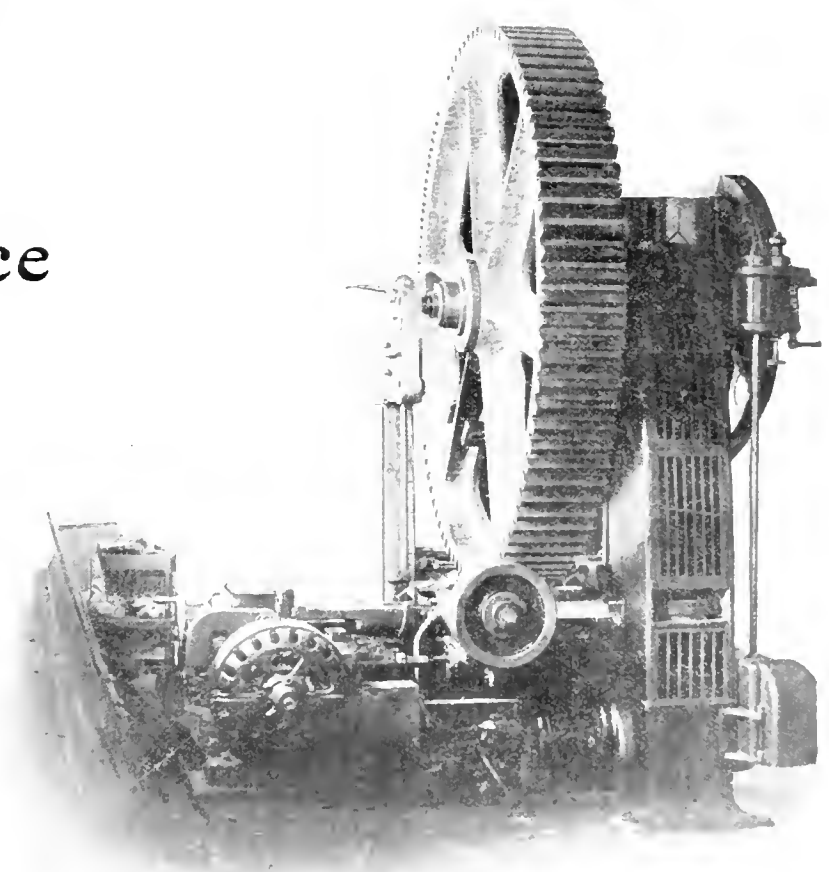

Write Us for
Quotations.

Cutting Heavy Spur Gear on 90-in. Brown & Sharpe

The Hamilton Gear & Machine Co.
Van Horne Street, TORONTO

If any advertisement interests you, tear it out now and place with letters to be answered.

General Office and Factory:
Aurora, Ont., Canada



The Positive Clutch &
Pulley Works, Limited

THE PRODUCT

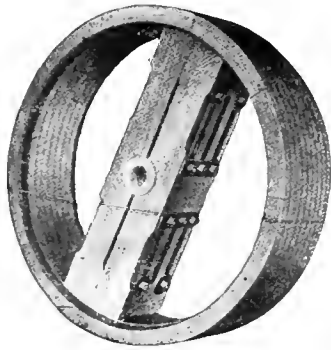

You cannot beat THE STEEL TRUST. But the Positive Wood Split Pulley will save every year \$3.00 that each metal-faced pulley costs you in belt slippage.

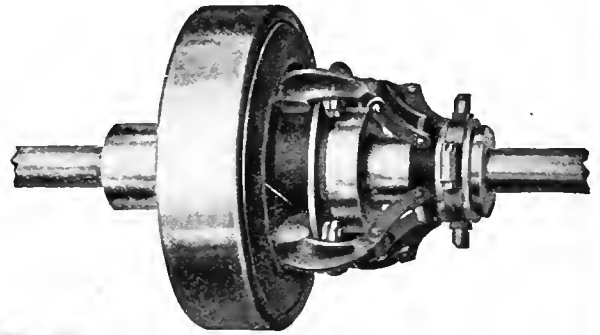

Positive Clutches

Save Belts

Save Time

Save Labor

Equip your machines with Positive Clutches in place of Tight and Loose Pulleys, which rapidly wear out and cannot be engaged quickly.

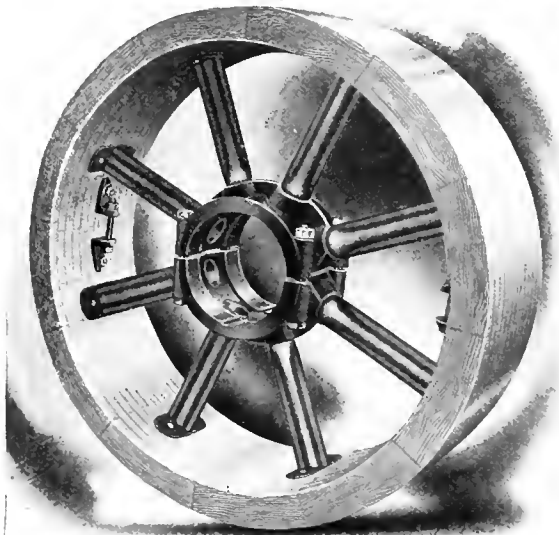

When you order Positive Wood Rim Steel Centre Pulleys you secure all that can be claimed for the Steel Pulley or the Wood Pulley, without the disadvantages of either. You will gain much by immediate action. We are now equipped and supplied ready to complete your requirements. Remember the three: "Positive Clutch," "Positive Wood Split Pulleys," "Positive Wood Rim Pulleys."

The Positive Clutch & Pulley Works, Limited

AURORA, ONTARIO, CANADA

WRITE FOR OUR CATALOGUE

Mention this paper when writing advertisers. It will identify the proposition about which you require information.

Last Call for the Diary

(of 1917)

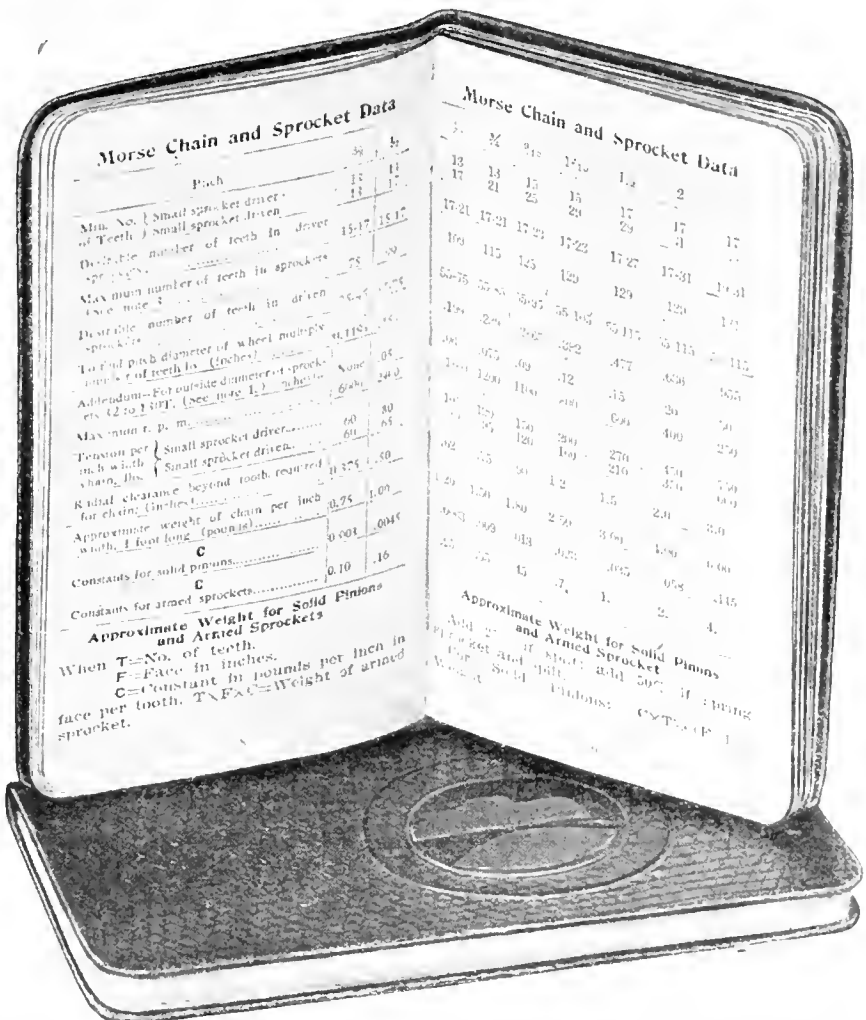

THE Morse Chain Company 1917 Diary is a diary in name only, the memorandum pages not being dated as in previous years. The book therefore does not get out of date as the year draws to a close.

Eighty 2 1/2 by 1 1/4 plain ruled pages, in addition to 48 pages of MORSE Chain Data and Illustrations, bound in genuine black leather, make a book but 3/4 inch thick and just the right size for the vest pocket.

Over 6000 of these little Memo and Data Books have so far this year been distributed to manufacturing plant men in the following positions:

- PRESIDENTS
- SUPERINTENDENTS
- MANAGERS
- MINING ENGINEERS
- VICE-PRESIDENTS
- PURCHASING AGENTS
- ELECTRICAL ENGINEERS
- AUTOMOBILE ENGINEERS
- SECRETARIES
- MASTER MECHANICS
- MECHANICAL ENGINEERS

In other words, we have given the book without charge or obligation of any kind to those to whom the data would be of value and who hold positions of authority as regards the purchase of equipment.

Only about 500 of the books are still available, and if you desire a copy we suggest filling out the coupon below and forwarding it to-day—to-morrow may be too late.

Morse Chain Company

ITHACA, N.Y., U.S.A.

Sales Offices in Many Important Cities
Manufacturers of "Rocker-Joint" Silent Chain
Power Transmission exclusively.



S-20

MORSE CHAIN CO., Ithaca, N.Y.
Please send free copy of your 1917 Vest Pocket Memo and Data Book to:

Name _____ Title _____
 Company _____
 Street _____
 City _____ State _____

Write plainly. C.M. 6-28-17

If any advertisement interests you, tear it out now and place with letters to be answered.



FOR FERTILIZER GRINDERS

AGRICULTURAL CHEMICAL WORKS

901-903 Macy Street,
Los Angeles, Calif.

10, 7, 16.

Magnolia Metal Company,

Gentlemen: Referring to your inquiry regarding Magnolia Metal would say that the same is satisfactory in every way and does all you claim for it. Since we began using this brand we have had practically no trouble with hot bearings, and can recommend it as the very best for high speed machinery.

We are running a fertilizer grinder at the rate of 1500 revolutions per minute, which at times creates considerable dust, and have had no occasion to re-babbitt the bearings since the last two years. This surely speaks for itself.

Yours truly,

AGRICULTURAL CHEMICAL WORKS,

By L. Baruch, Sec'y.

PRACTICAL ENGINEER POCKET BOOK:

Over 600 pages. A valuable reference work imported from England and sold as an advertising medium at the low price of 40c post paid.

Address Montreal Office.

SOLD BY LEADING DEALERS EVERYWHERE OR BY

MAGNOLIA METAL CO.

OFFICE AND FACTORY:

225 St. Ambrose St.

MONTREAL

CUT GEARS

Theoretically Correct

PROMPT SERVICE

ROBERT GARDNER & SON

LIMITED

52 NAZARETH ST., MONTREAL, P. Q.

RAWHIDE

OR METAL

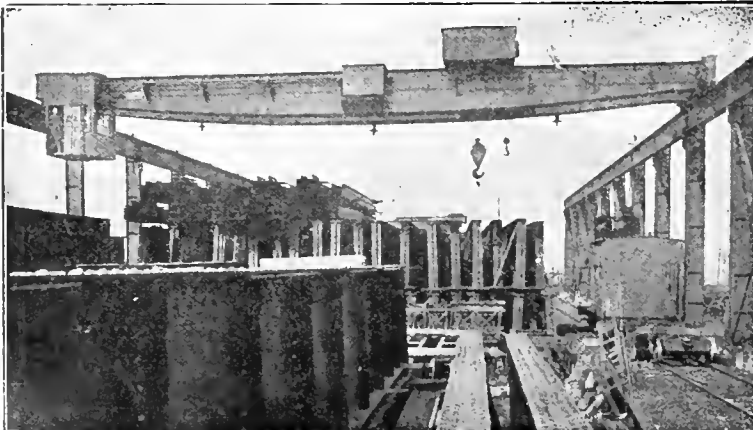

Electric Travelling Cranes

(Direct or Alternating Current)

Steam and Electric Derricks

(Stationary or Travelling)

Up-to-date design. Built for fast, continuous service.

ACCESSIBILITY—DURABILITY.

Dominion Bridge Company, Limited

MONTREAL

Mention this paper when writing advertisers. It will identify the proposition about which you require information.

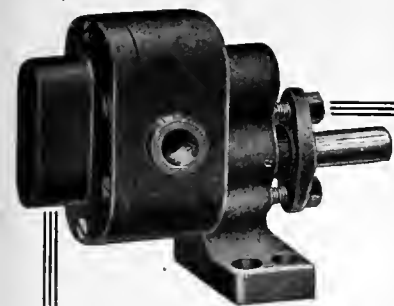

Speed Up—

You can speed up that machine to its highest capacity and rest assured that Roper's Circulating Pump will keep the machine well oiled.

The machine is so constructed that the lubricant will flow in a steady stream, no halting, pulsating movement at all. This is a feature well worthy of notice. The circular is made in 6 sizes and will adjust itself to any size machine. The pump shown is a one-way lubricator only. We make the other kind.

Inquire.

C. F. ROPER & CO.
HOPEDALE : MASS. : U.S.A.



ECONOMIC WATER OIL

SHELL MANUFACTURERS use ECONOMIC WATER OIL for METAL CUTTING of every description; it will not gum nor rust, and it SAVES TIME AND LABOR.

WE CAN SAVE YOU 50% in the COST of your CUTTING MIXTURE BECAUSE

ONE GALLON of ECONOMIC WATER OIL will mix readily with 30 to 50 gallons of WATER, making a thick, creamy emulsion, and giving you a cutting mixture which will not only be satisfactory, but, will produce very ECONOMIC RESULTS.

One TRIAL ORDER will prove our STATEMENT.

Made in Canada

Canadian Economic Lubricant Co.
LIMITED

1040-1042 Durocher St.

MONTREAL

The Whiting Type "R" Crane

is fully meeting the demands of severe service. Very accessible, very simple and very rigid in design.

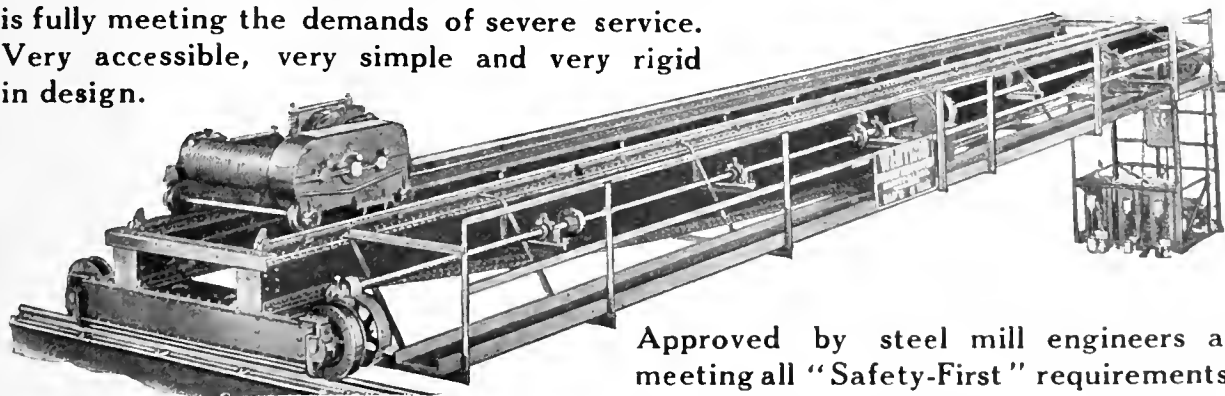

Approved by steel mill engineers as meeting all "Safety-First" requirements.

Trolleys made in standard sizes from 1 to 100 tons capacity. All gears on trolley operate in oil in dust-proof cases. Specify a Whiting Type "R" crane on your next inquiry.

New Crane Catalog on Request.

Complete Foundry Plants

Designed, equipped and put into operation

CRANES OF ALL TYPES



If any advertisement interests you, tear it out now and place with letters to be answered.

SURROUND YOUR BUSINESS WITH NEVER-FAIL BELTING

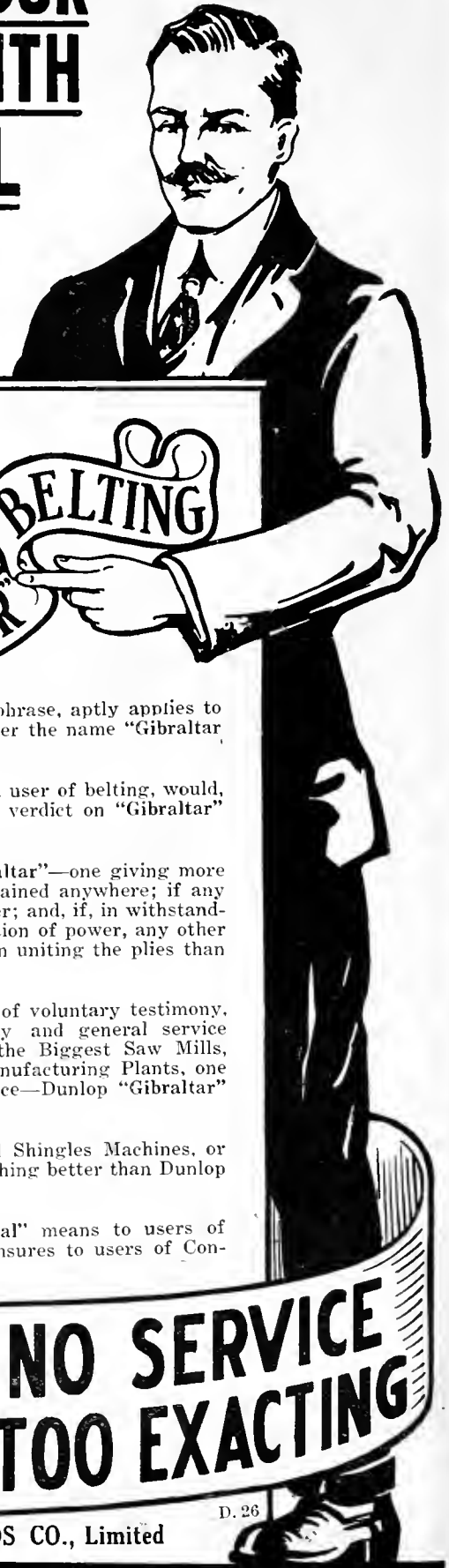

"Strength of Gibraltar," while not our phrase, aptly applies to the rubber belting made by us and sold under the name "Gibraltar Redspecial."

* * *

It would be interesting to us if you, as a user of belting, would, before making your next purchase, get a verdict on "Gibraltar" from some of your friends.

* * *

Ask them if a stronger belt than "Gibraltar"—one giving more service with less loss of power—can be obtained anywhere; if any other product will survive heavy loads better; and, if, in withstanding the jerky strains consequent on fluctuation of power, any other belt can show a higher quality of friction in uniting the plies than "Gibraltar Redspecial."

* * *

We have evidence aplenty, in the form of voluntary testimony, which shows that for strength, durability and general service "Gibraltar Redspecial" is matchless. In the Biggest Saw Mills, Biggest Pulp and Paper Mills, Biggest Manufacturing Plants, one "driving force" is nearly always in evidence—Dunlop "Gibraltar" Belting.

* * *

For Drives, Rotaries, Edgers, Lath and Shingles Machines, or any kind of Transmission work, there is nothing better than Dunlop "Gibraltar Redspecial" Belting.

* * *

And what Dunlop "Gibraltar Redspecial" means to users of Transmission Belting, Dunlop "Samson" ensures to users of Conveyor or Elevator Belting.

**NO LOAD
TOO HEAVY**

**DUNLOP
"GIBRALTAR"
BELTING**

**NO SERVICE
TOO EXACTING**

DUNLOP TIRE & RUBBER GOODS CO., Limited

D. 26

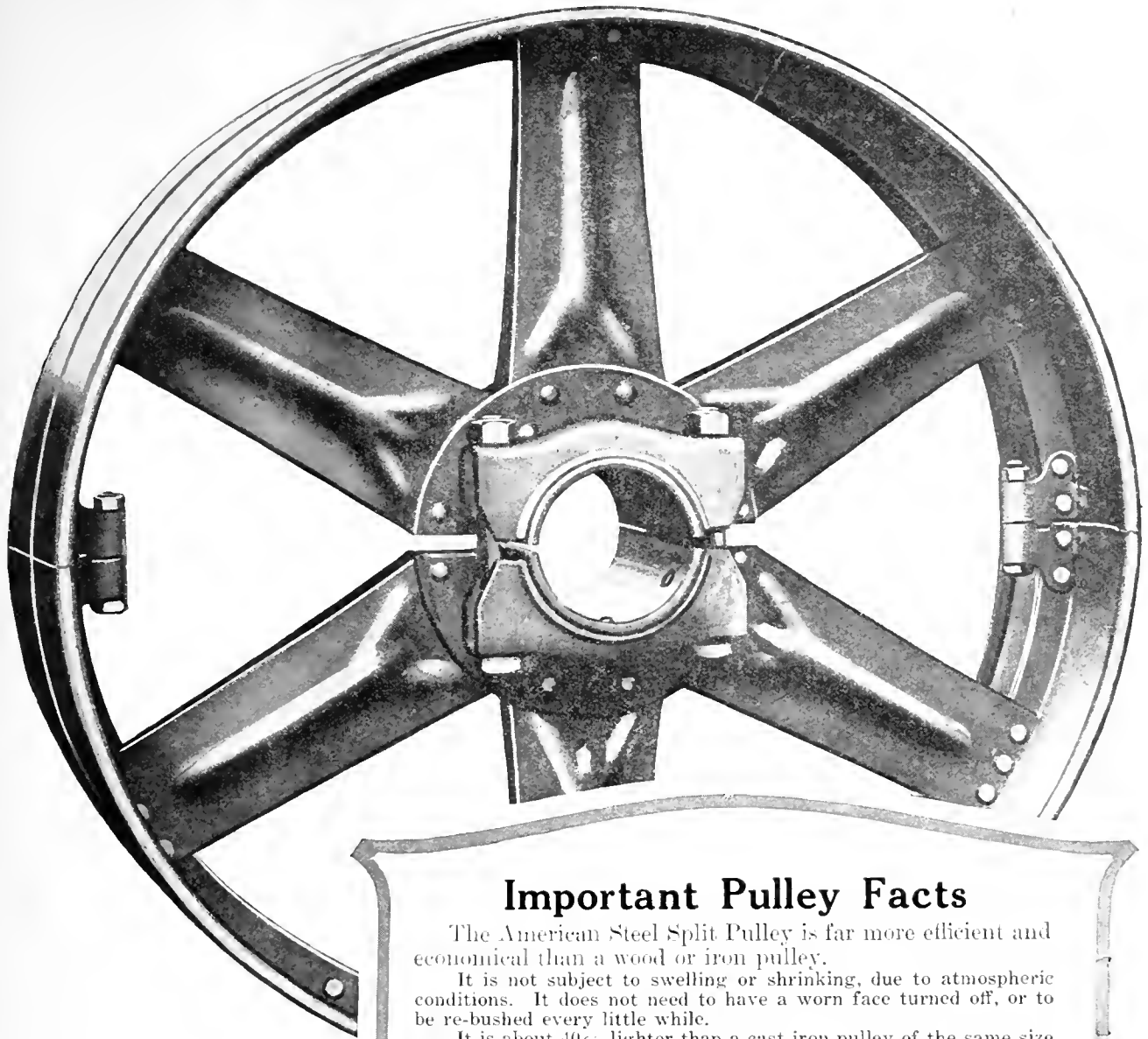

Important Pulley Facts

The American Steel Split Pulley is far more efficient and economical than a wood or iron pulley.

It is not subject to swelling or shrinking, due to atmospheric conditions. It does not need to have a worn face turned off, or to be re-bushed every little while.

It is about 40% lighter than a cast iron pulley of the same size and its steel face holds a belt with much less belt-slip than a cast iron face. This is very important, for belt-slip is a constant leak and loss of power.

AMERICAN STEEL SPLIT PULLEYS

"Americans" are guaranteed to perform double belt duty under all ordinary conditions. They will endure higher speeds than any other standard metal pulley. Their flat A-braced arms cut the air and reduce wind resistance to a minimum.

Write for the free book "Pulley Efficiency," and you will know why American Pulleys are big money-savers—why there are over three million in use—more than of any other one make.

THE AMERICAN PULLEY COMPANY
PHILADELPHIA, PA.

Canadian Distributors:

Williams & Wilson, Ltd.	- - - - -	Montreal, Quebec.
A. R. Williams Machinery Company	- - - - -	St. John's, N.B.
A. R. Williams Machinery Company	- - - - -	Toronto, Ontario.
A. R. Williams Machinery Company	- - - - -	Vancouver, B.C.
A. R. Williams Machinery Company	- - - - -	Winnipeg, Manitoba.
H. W. Petric, Ltd.	- - - - -	Toronto, Ontario.

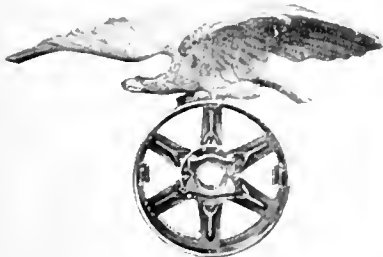

If any advertisement interests you, tear it out now and place with letters to be answered.

THE FORD TRIBLOC

Good Reading on Good Hoists

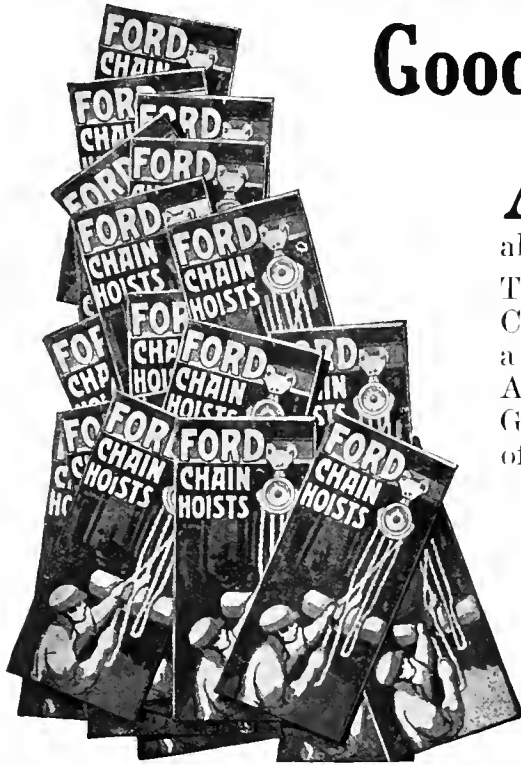

A success is always worth reading about. Especially so when it is of the Longfellow variety—the kind that attains the heights by forging ahead while others slumber.

There's a big idea behind the success of Ford Tribloc Chain Hoists. The idea of getting better service out of a hoist by putting better materials and features into it. All-steel working parts, non-gagging LOOP Hand Chain GUIDE, planetary type of spur gearing—those are some of the meritorious features of Ford construction.

They are worth reading about in detail in our new Catalog. How shall we address it?

Ford
of Philadelphia

FORD CHAIN BLOCK & MANUFACTURING CO.
139-141 Oxford St. PHILADELPHIA, PA.

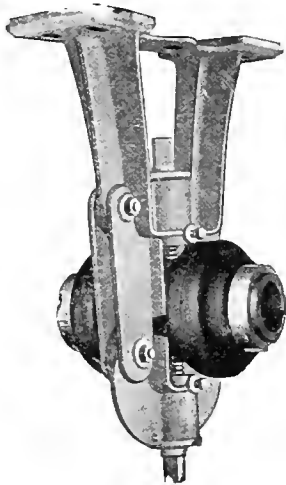

LESS FRICTION—LESS POWER LOSS

There is 75%
Less Friction
with

Chapman

Double Ball Bearings

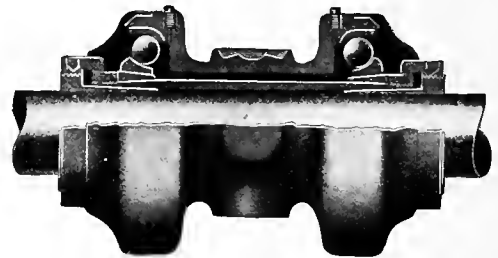

A factor of well recognized importance in a shaft hanger is Power Cost. Power cost goes up with increased friction. Friction in a well designed ball bearing is far less than in a sliding bearing. Then since Chapman Double Ball Bearings are designed solely for transmission purposes, users save 75% of friction loss in transmitting power. Use of Chapman Ball Bearings means a saving in oil, a saving in labor of oiling and general attention required in Babbitted shaftings—and they are thoroughly dust-proof.

Chapman Double Ball Bearing Company of Canada, Limited

339-351 Sorauren Avenue, Toronto, Ontario

Transmission Ball Bearing Company, 1050 Military Road, Buffalo, N.Y.

The FOSS & HILL MACHINERY Co.

305 ST. JAMES ST., MONTREAL, QUE.

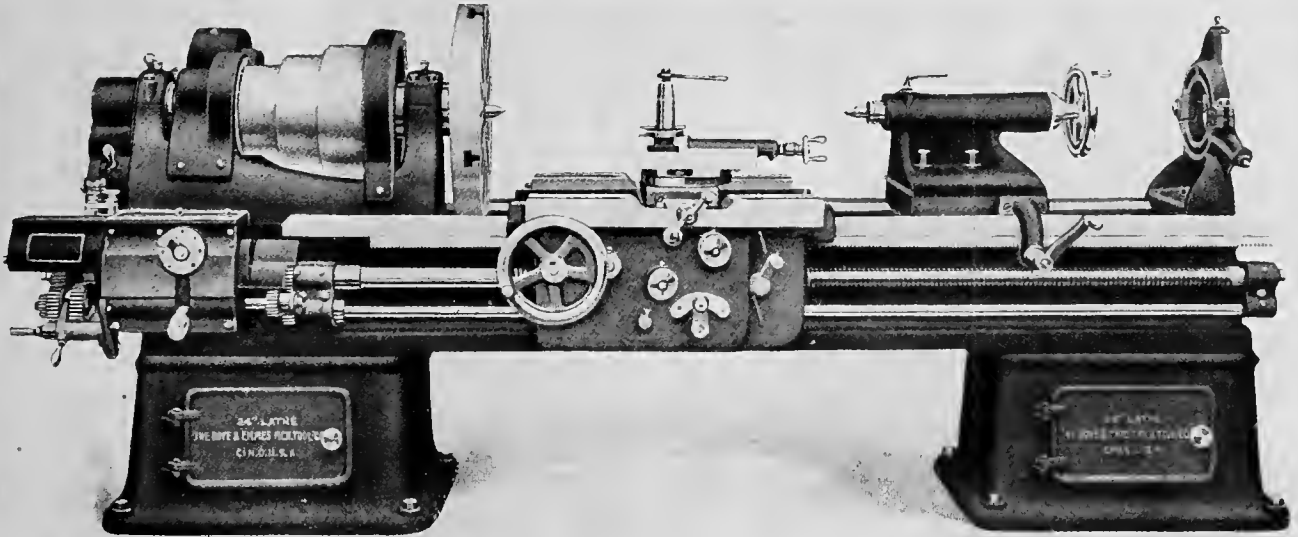

We Have a Few Boye & Emmes Lathes in Montreal for Immediate Delivery

Service is our principal and we always endeavor to give our customers the very best attention possible.

We carry a large stock of Machine Tools and Supplies of the best makes.

If you have not received one of our machinery stock lists advise us and we shall be pleased to send you one.

We solicit your inquiries.

The Foss & Hill Machinery Company

305 St. James Street, MONTREAL, QUE.

If any advertisement interests you, tear it out now and place with letters to be answered.

The FOSS & HILL MACHINERY Co.

305 ST. JAMES ST., MONTREAL, QUE.

LEATHER BELTING

All Sizes and Plies

Quality Guaranteed

COTTON BELTING "AZAK"

THE LATEST IMPROVED

SOLID WOVEN COTTON BELTING

PLIABLE, WILL NOT CRACK

VERY LITTLE STRETCH

McARTHUR BELTINGS LIMITED

Factory—Brockville, Ont.

Stock carried by FOSS & HILL MACHINERY CO., Montreal



ALLEN
Socket Cap
Screw

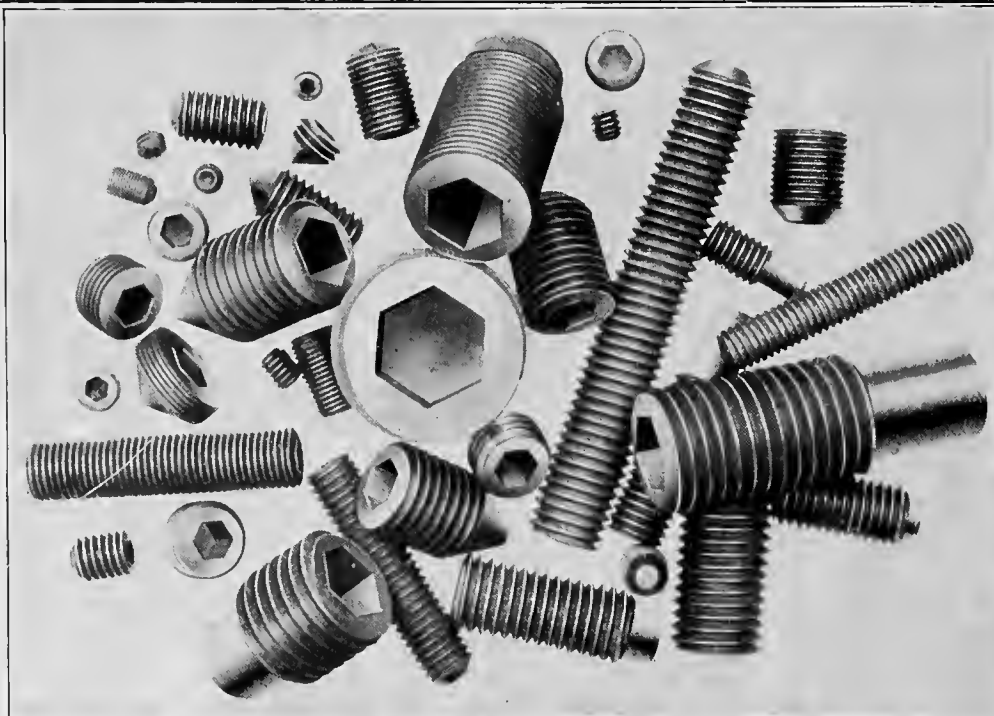

ALLEN
Socket Cap
Screw

ALLEN SAFETY SET SCREWS—EVERY DIAMETER, ALL LENGTHS

Allen Safety Set Screws are made in every diameter, every length and every shaped point for any purpose to which a safety set screw can be put. The diameters range from 1/4-inch up to 1 1/2 inches.

All "Allen" Screws are made by a Patent process which produces a clean socket and adds 30% more strength to the screw. Large assortment of V threads in stock at special Jubilee prices.

The Allen Manufacturing Company, 135 Sheldon St., Hartford, Conn., 173 Princess Street, Manchester, England

The FOSS & HILL MACHINERY Co.

305 ST. JAMES ST., MONTREAL, QUE.

Machinists' Necessities

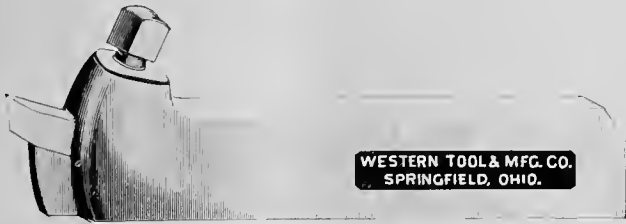

"Champion" Turning Tool



"Champion" Boring Tool

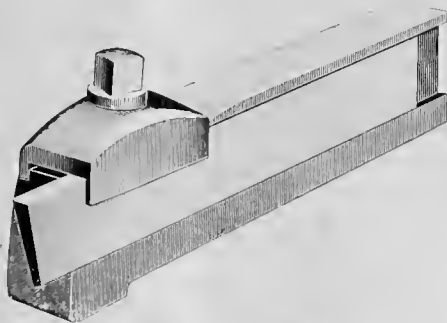

"Champion" Cutting-off Tool

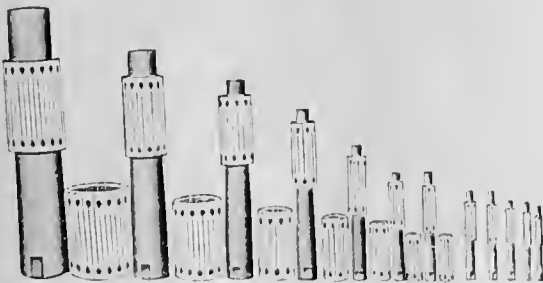

"Champion" Expanding Mandrel

CHAMPION tools are economical both as to actual cost and operation. Our expanding mandrels cost about one-sixth the price of solid arbors of equal range. When you take into consideration the time consumed in looking for an arbor and the difference in the cost, the economic feature is all one-sided. The quality of the tools are up to the "Champion" standard.

The cutting-off and turning tools are above the ordinary. They are "Champion" quality.

An inquiry would demand our immediate attention and co-operation.

Western Tool & Mfg. Co.

Springfield, Ohio, U.S.A.

If any advertisement interests you, tear it out now and place with letters to be answered.

The FOSS & HILL MACHINERY Co.

305 ST. JAMES ST., MONTREAL, QUE.

The Radial With The Stamina

IT isn't enough that a radial drill is correctly designed. Continued accuracy, speed and convenience depend much on the stamina of the material that is used in construction.

Much as the large, deep and heavily reinforced base, the stationary one-piece patented column with its four full-length webs, the large bearing surface of the arm and the rigid clamping arrangement contribute to the success of the Mueller Radial, it is to the *material* used in each one of these parts that a great deal of credit belongs.

Why the Mueller Radial is the drill with unusual stamina is *fully* explained in our catalog. Proof of unusual performance can be seen every day in the many shops where the Mueller is used.

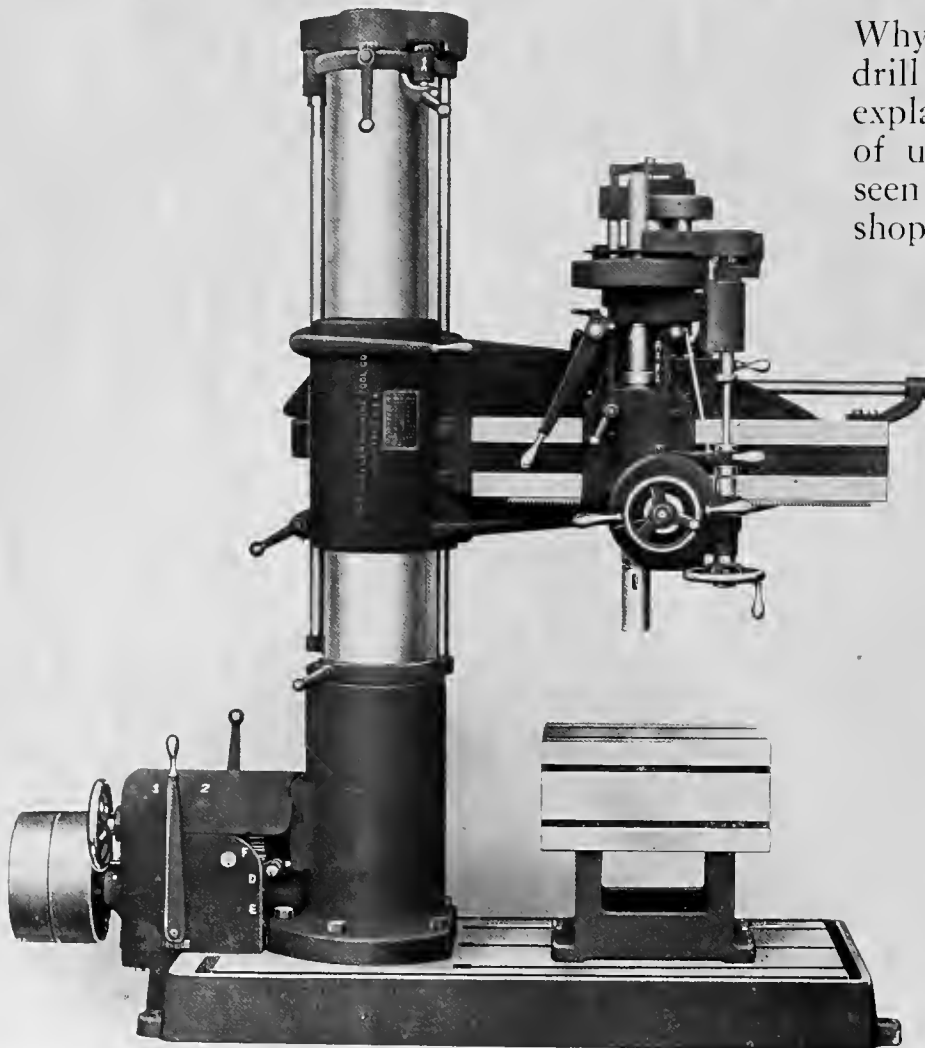

THE MUELLER MACHINE TOOL COMPANY

Radial Drills and Lathes

CINCINNATI, OHIO

Mention this paper when writing advertisers. It will identify the proposition about which you require information.

The FOSS & HILL MACHINERY Co.

305 ST. JAMES ST., MONTREAL, QUE.

The Mueller Engine Lathe 18-Inch Standard Heavy Duty Type

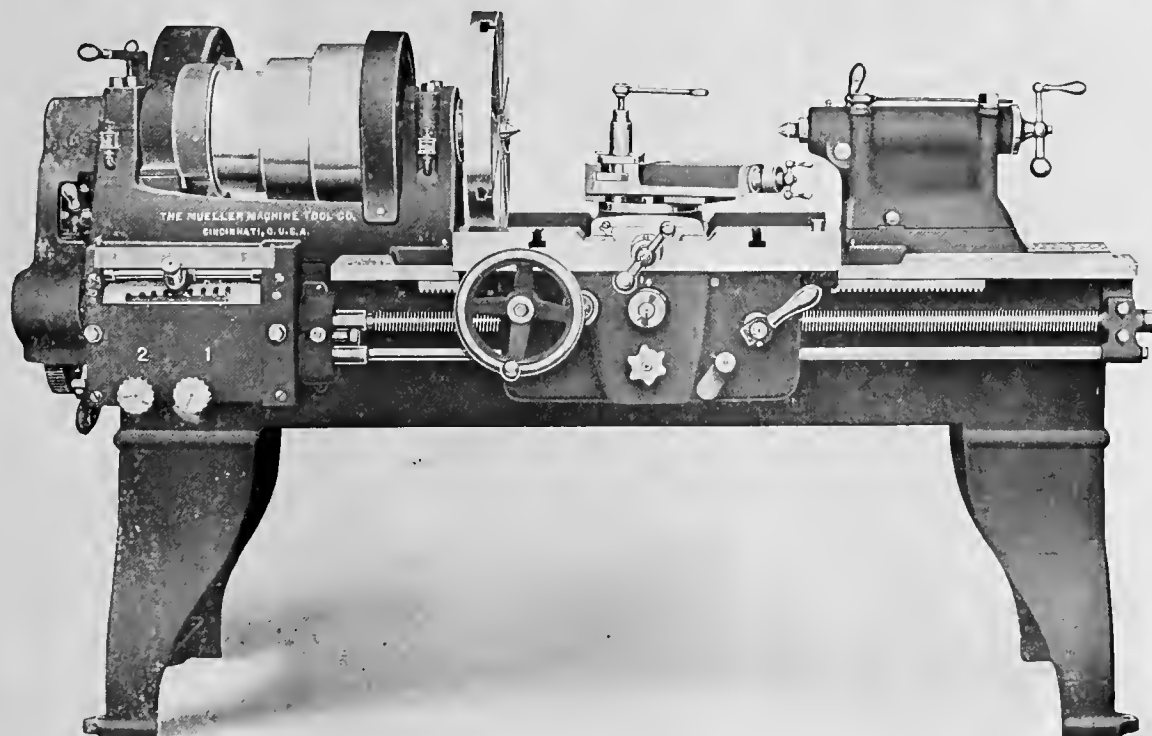

There's a growing demand for a medium size lathe that can handle manufacturing and general shop work with accuracy, speed and profit—a rapid, rigid, wide-range lathe—and to meet these requirements we offer the 18" Mueller Engine Lathe.

The keynote of Mueller construction is rigidity. It is insured by an exceptionally deep bed, stocky legs, heavy head and tail stocks, spindle provided with heavy steel thrust collars and means for taking up wear, long spindle bearings, and by a general guarding against the inroads of hard usage. On the Mueller 15 threads can be cut with changes obtained within the gear box; there are 18 spindle speeds.

The Mueller Engine Lathe is adapted for light or heavy cuts, high or low speeds, for literally ripping off stock or chasing a fine thread, and in addition, handles a wide variety of work *without special attachments*. Operation is simple, convenient and safe.

For economical reasons investigate Mueller advantages before you buy lathes.

The Mueller Machine Tool Company
CINCINNATI Radial Drills and Lathes OHIO, U.S.A.

If any advertisement interests you, tear it out now and place with letters to be answered.

The FOSS & HILL MACHINERY Co.

305 ST. JAMES ST., MONTREAL, QUE.



MOVE PRODUCTION!



**Lathes put
a strong shoulder
to the wheel!**

ASK

The
**FOSS & HILL
MACHINERY
COMPANY
MONTREAL**

Regarding
"SIDNEY" LATHES

"Sidney for Service" Lathes put a strong, intelligent shoulder to the production wheel—and send operations forging ahead. Does it ever seem that production moves too slowly? Have you tried Sidneys?

They *push* production and *hold back* costs

Naturally, there are a large number of mechanical reasons why our patrons—among whom are the finest, most efficient firms in Canada and the United States—are so thoroughly pleased with RESULTS SECURED.

Bulletin No. 30 gives some of these reasons. It's free. Get in touch with our Agents and they'll tell you all the reasons, and give you the evidence. Move your production rapidly and economically with "Sidney for Service" Lathes.

Manufactured by

THE SIDNEY TOOL COMPANY

**SIDNEY
OHIO, U.S.A**

SIDNEY

*for
Service*

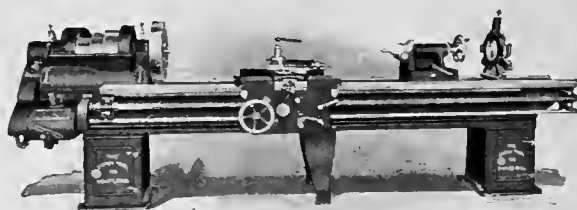

SIDNEY

*for
Service*

The FOSS & HILL MACHINERY Co.

305 ST. JAMES ST., MONTREAL, QUE.

KEMPSMITH

No. 3 PLAIN MILLER

Large diameter cone for wide double belt.

Double back gears.

All feed changes made while machine is running.

Power feed in all directions.

All feeds reversed by one lever at front of knee.

All feeds tripped and engaged by one compound lever at front of knee.

Our catalog explains these and many other features in full detail. Sent gladly on request.

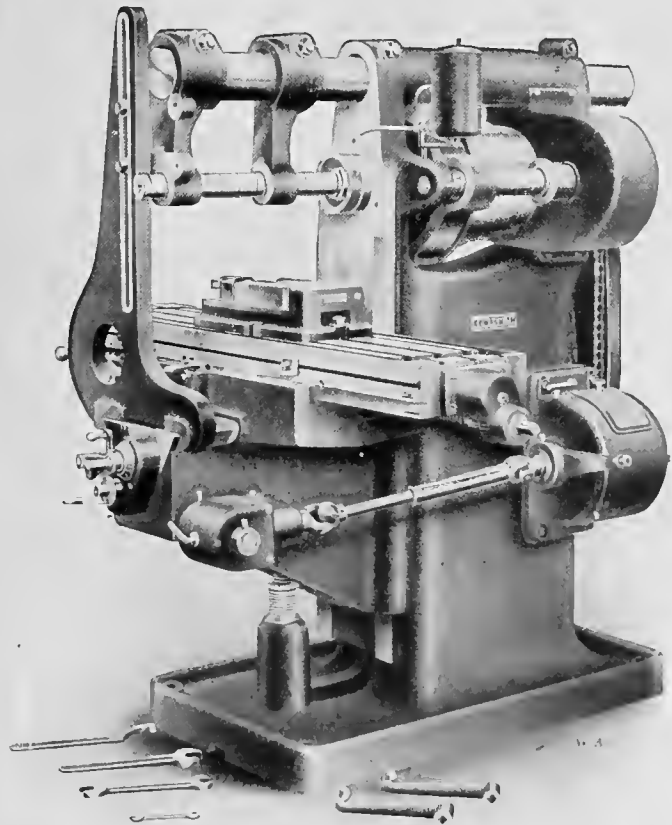

**The Kempsmith Mfg.
Company**

Milwaukee, U.S.A.

The Foss & Hill Machinery Co.
Montreal, Quebec

Agents for Quebec

If any advertisement interests you, tear it out now and place with letters to be answered.

The FOSS & HILL MACHINERY Co.

305 ST. JAMES ST., MONTREAL, QUE.

THE ONLY WAY

to get Babbitt and White Metal Products that are as good as "DO-ME-KO" is to buy

DO-ME-KO

It stands in a class by itself.



DO-ME-KO

Babbitt and White Metal Products

are especially designed to meet exacting needs of modern machinery. **EVERY POUND IS GUARANTEED.**

Prices are right. Delivery the best.

Catalogue giving valuable information mailed free upon request.

THE DOMINION METAL COMPANY, LIMITED

SHERBROOKE, QUE., CANADA

FOSS & HILL MACHINERY COMPANY 305 St. James St., Montreal, Que., Selling Agents for Montreal.

MACHINE TOOLS IN STOCK

- | | |
|--|--|
| <ul style="list-style-type: none"> 1—16" Ohio Heavy Duty Shaper 1—20" Ohio Heavy Duty Crank Shaper 1—20" Smith & Mills B.G. Crank Shaper 1—24 x 24 x 6 Gardiner Planer 1—Fraser Universal Cutter and Tool Grinder, complete with regular equipment 2—No. 3 Ohio Universal Cutter and Tool Grinders, complete with regular equipment 1—No. 2B Hendey Heavy Duty Universal Milling Machine 2—No. 25 Ohio Full Universal Heavy Duty Milling Machines. 1—No. 2 Brown & Sharpe plain Milling Machine 1—B.X. Yankee Cutter and Reamer Grinder with drill grinding attachment 1—Style B Yankee Twist Drill Grinder 1—Style F Yankee Twist Drill Grinder 1—Garvin Surface Grinder 1—450-lb. Bell Steam Hammer (used) 1—180 Brown & Boggs Inclinable Back Power Press 1—200 Brown & Boggs Inclinable Back Power Press 1—No. 2—36 x 14½ Brown & Sharpe Vertical Chucking Machine (used) 1—2" Universal Bolt Cutter | <ul style="list-style-type: none"> 1—1" Henry & Wright Class B Sensitive Drill 1—Type B.W. Sipp Back Bearing H.S. Sensitive Drill 12—20" Back Geared drill presses 3—24" Sibley sliding head drill presses 1—28" Sibley sliding head drill press 2—24" Doye & Emmes Lathes, 3 step cone, double back geared 6—26" Boye & Emmes Lathes, 3 step cone, double back geared 4—30" Boye & Emmes Lathes, 3 step cone, double back geared 5—21 x 8 Le Blond Heavy Duty Turret Lathes, O.C. gear box, air cylinder and chucks, for 4.5 shells (used) 12—21 x 8 Le Blond, Q.C.G. Automobile Turning Lathes, air cylinder and mandrels, for 4.5 shells (used) 6—18 x 8 Battle Creek Heavy Duty 4.5 Shell Turning Lathes, with air cylinder and mandrel (used) 6—19" Sidney Q.C.G. Lathes, regular equipment 1—17" Sidney Q.C.G. Lathe, regular equipment 1—19" Sidney Q.C.G. Lathe, equipped with taper attachment 1—12 x 5 Mulliner Tool Room Lathe with taper attachment, draw-in attachment and collets |
|--|--|

The Foss & Hill Machinery Company

305 ST. JAMES ST., MONTREAL, QUE.

Mention this paper when writing advertisers. It will identify the proposition about which you require information.

The FOSS & HILL MACHINERY Co.

305 ST. JAMES ST., MONTREAL, QUE.

"It would be impossible to operate my department without the MERCURY METHOD. If I used the old method under present conditions, my men would lose much time waiting in narrow aisles for others to get out of the way"

says a foreman of one of the largest plants in the country.

"THE TRACKLESS TRAIN"

Eventually every Canadian plant will be using electricity for trucking purposes. Inter-transportation is a big item of expense, and more and more manufacturers, realizing the need of efficiency in every department, are thinking seriously about the time, money and labor wasted by the hand-trucking method and of means to eliminate that waste and place his labor on the productive payroll.

There are many ways in which electricity is used to save time and money—to replace manual labor,—and it can be used most effectively in Canadian plants in solving the internal-transportation problem.

The usefulness of a

"MERCURY"

INDUSTRIAL TRACTOR

is almost unlimited. With the aid of trailers, one tractor may be made to do the trucking for various departments.



One man to operate the tractor and just a sufficient amount of common labor for loading trailers is all that is necessary with this efficient system.

A force of experienced engineers is maintained by us and one will be sent to your plant to go over conditions upon request. A complete analysis of your problem will put you to no expense or obligation.



Write to-day for descriptive catalog.

MERCURY MANUFACTURING COMPANY, 4006 South Halsted St., CHICAGO, U. S. A.

Represented by Foss & Hill Machinery Co., 321 St. James St., Montreal

Laing & Walsh, 32 Front St., W., Toronto



The FOSS & HILL MACHINERY Co.

305 ST. JAMES ST., MONTREAL, QUE.

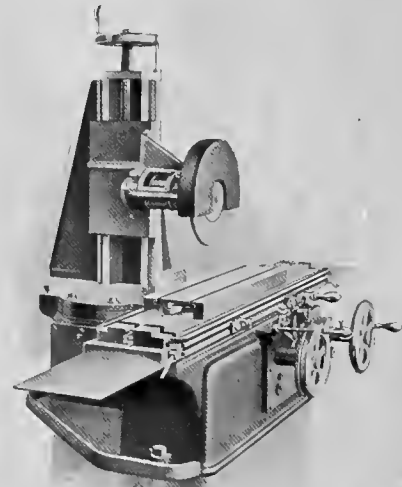
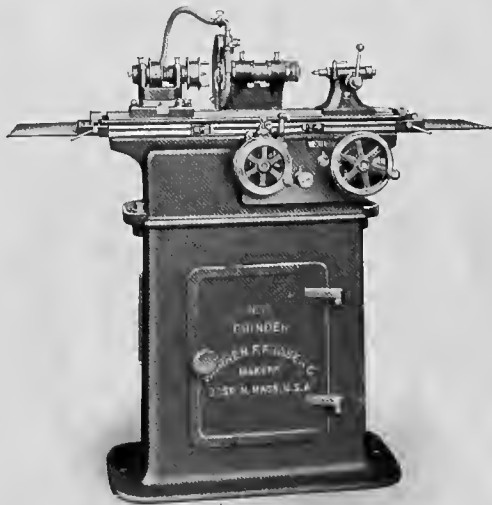

From This _____ To This Converted in a Few Moments

Machine illustrated above is set up for cylindrical grinding. The great speed attained or the variable speed desired makes this machine adaptable to many uses. Yet put in place where only one variety of work is required and it will outstrip all machines of a similar nature.

It requires only a few moments to convert this machine to the above surface grinder. Its versatility gives it an added value that constitutes a decided asset to any shop. It has an even, clean movement and gives the wheel a sharp, clean-cut motion.

SINGLE-PURPOSE or multi-purpose just as your requirements demand—so is the Fraser Universal Grinder. If for single purpose, the speed, strength and efficiency of the machine will be a constant production increaser and cost-reducer. If for multi-purpose use the convertibility of this machine to do surface, cylindrical or internal grinding will prove of great profit and benefit. The attachments for these purposes may be detached or put on in a moment or two, and you will express enthusiastic satisfaction at its efficiency in all its various operations.

The Warren F. Fraser Co.

Freeport Street

Boston, Mass., U.S.A.

Canadian Agents: Foss & Hill Machinery Co., Montreal, Que.

The FOSS & HILL MACHINERY Co.

305 ST. JAMES ST., MONTREAL, QUE.

Racine High-Speed Metal Cutting Machines

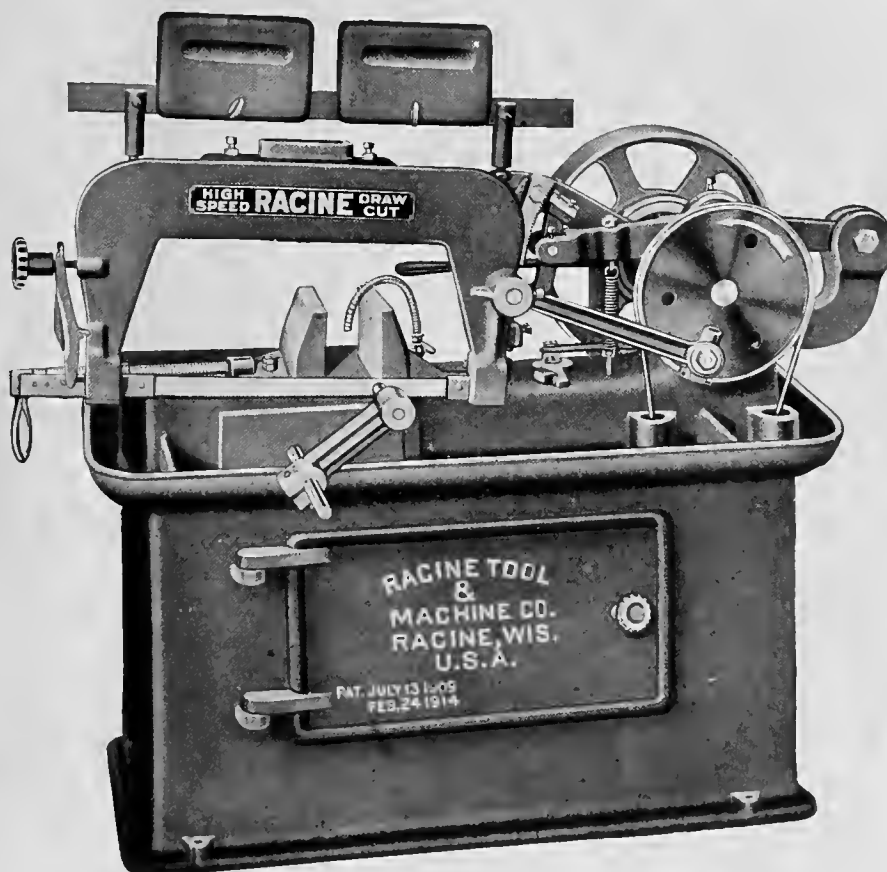

The **RACINE** is the original high-speed draw-cut metal-cutting machine noted the world over for its simplicity and rigid construction.

The **RACINE** has faithfully met all requirements for metal cutting in the past ten years throughout the world, both in regular work and in hundreds of munition factories.

The **RACINE** requires no skilled labor to operate it.

Order a **RACINE** from your dealer, understanding that we endorse any fair proposition the dealer makes you, as we fully guarantee our machines in every particular.

The **RACINE** wears the badge of honor for loyalty and faithful performance of the work allotted to it behind the trenches.

Write for Catalogue to-day.

Racine Tool & Machine Company, Racine, Wis., U.S.A.

If any advertisement interests you, tear it out now and place with letters to be answered.

The FOSS & HILL MACHINERY Co.

305 ST. JAMES ST., MONTREAL, QUE.



GARDNER MACHINE COMPANY



Two "Over-size" Gardner Grinders

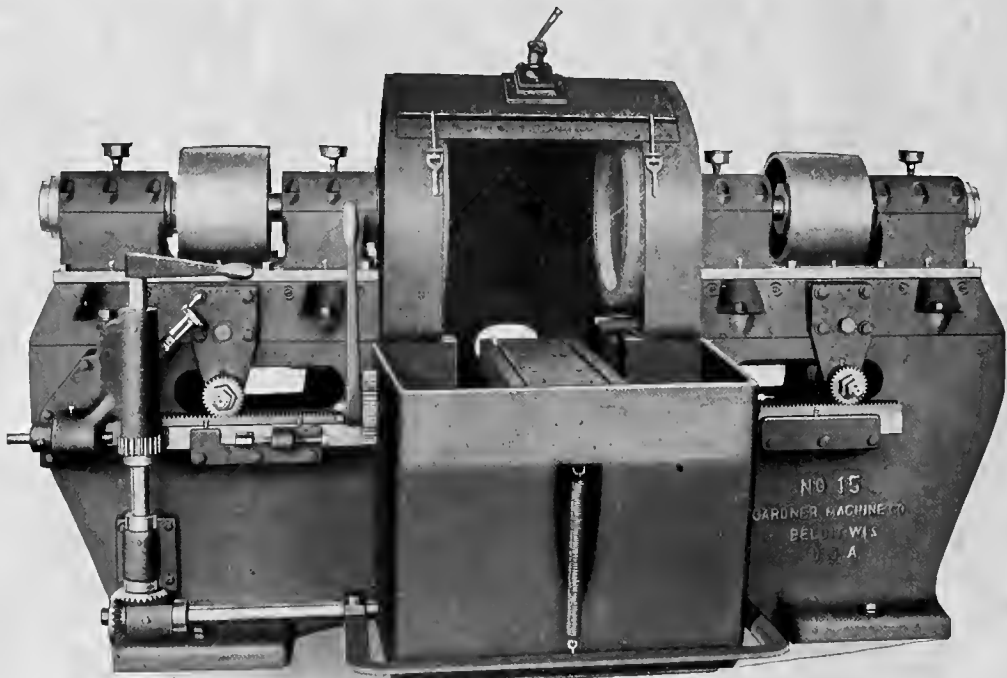

Double Spindle Grinders

The No. 15 Grinder as illustrated above is the largest and most powerful machine of this type on the market. It carries either 24-inch diameter disc wheels or 20-inch diameter ring wheels, both of which grinding members are interchangeable. The spindles are 3 inches diameter and the spindle pulleys are 12-inch diameter by 8½-inch face. The sliding cross-feed table is of rigid construction, making a powerful equipment which will handle large work on an economical scale.

Double Spindle Gardner Grinders are made in these sizes:

- No. 120 with 18-inch disc wheels or 14-inch ring wheels.
- No. 14 with 20-inch disc wheels or 16-inch ring wheels
- No. 15 with 24-inch disc wheels or 20-inch ring wheels

These machines are being used in scores of different lines of manufacture, and right now are in especial demand by up-to-the-minute builders of guns, ammunition and motor cars. If you have any parts which are adapted to finishing on this type of machine you should investigate at once. Gardner Grinders are increasing outputs over other methods from 2 to 100 times. Send us to-day your samples for a free grinding demonstration or blue prints for an estimate. TO-DAY.

We are making exceptionally good deliveries on many types and sizes

GARDNER MACHINE COMPANY, Beloit, Wisconsin



DISC GRINDING MACHINERY



The FOSS & HILL MACHINERY Co.

305 ST. JAMES ST., MONTREAL, QUE.



GARDNER MACHINE COMPANY

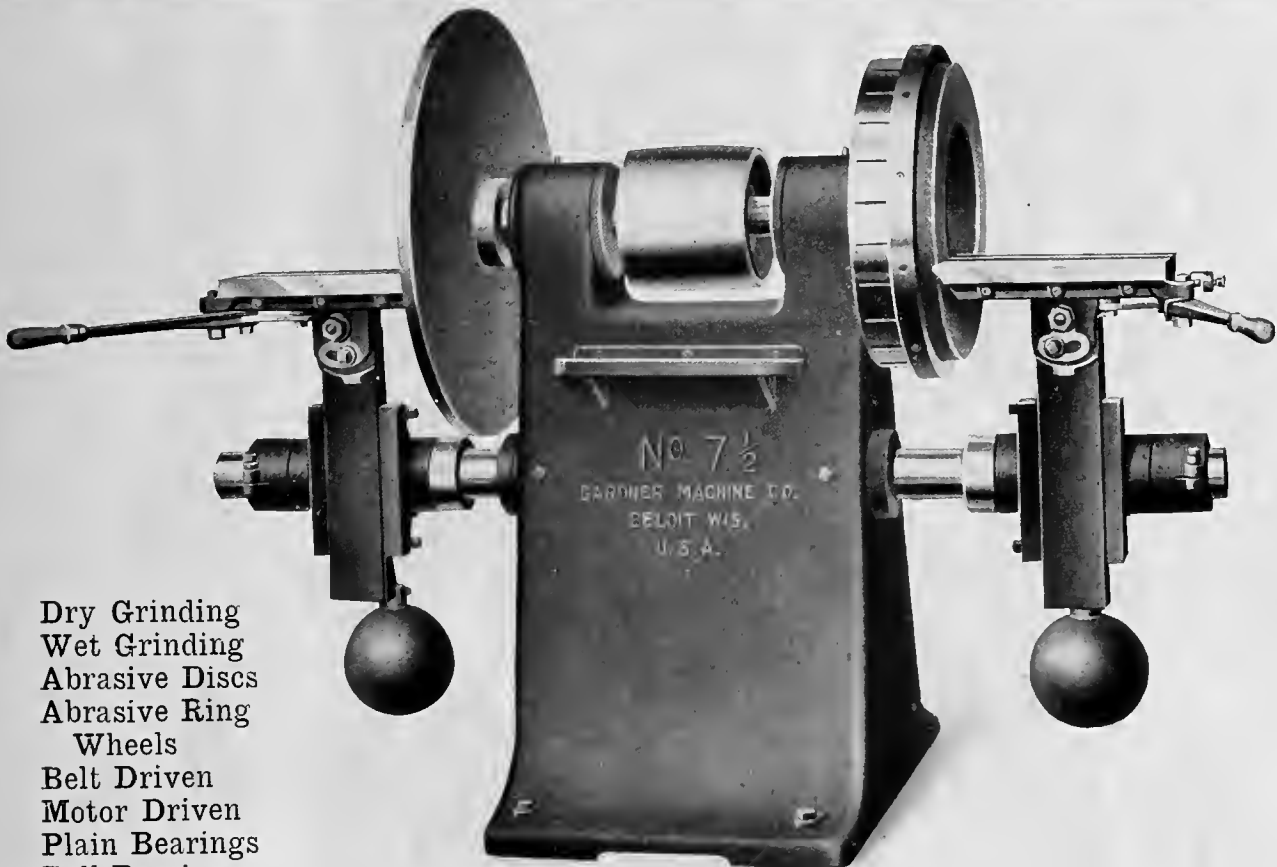

Dry Grinding
Wet Grinding
Abrasive Discs
Abrasive Ring
Wheels
Belt Driven
Motor Driven
Plain Bearings
Ball Bearings

Single Spindle Grinders

Here is our new No. 7 $\frac{1}{2}$ machine—a 30-inch disc wheel capacity grinder with unusually large dimensions throughout. The disc wheels are interchangeable with the 20-inch ring wheel chucks. The spindle is 2 $\frac{3}{4}$ inches diameter and is mounted in self-aligning radial and thrust ball bearings. The rocker-shaft is 3 $\frac{1}{2}$ inches diameter and supports two Lever Feed Tables of rigid design. Abundant belt power is provided for through the spindle pulley which is 10 inches diameter by 9 inches face.

Single spindle Gardner Grinders of this type are made in the following sizes: No. 1, 12-inch wheels; No. 2, 18-inch wheels; No. 4, 20-inch wheels; No. 6, 26-inch wheels; No. 7, 30-inch wheels; No. 7 $\frac{1}{2}$, 30-inch wheels; No. 8, 40-inch wheels.

There is a Gardner Grinder made for any possible disc grinder operation. A range of disc wheels from 12 inches to 40 inches diameter; or Perfection Ring wheel chucks from 8 inches to 24-inch.

If you have a disc or ring wheel grinder job you should take it up at once with "The Authorities" on this subject. Our Experimental Department is conducted solely to give valuable service to the trade. Use it—its free reports are interesting, intelligent and absolutely authentic. Use it—now.

We are making exceptionally good deliveries on many types and sizes

GARDNER MACHINE COMPANY, Beloit, Wisconsin



DISC GRINDING MACHINERY



The FOSS & HILL MACHINERY CO.

305 ST. JAMES ST., MONTREAL, QUE.

Sweetland Combination and Universal Trucks

Made with Three or Four Jaws

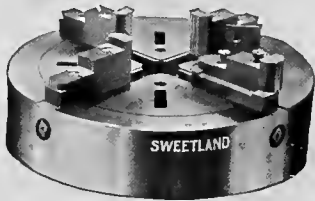

A "Combination" Chuck is one in which the Jaws can be operated either independently or universally, as desired.

On account of the simplicity and completeness of its interchangeability from the independent to the universal operation of the jaws, or *vice versa*, and the unusual strength of this Reversible Jaw, this Chuck is acknowledged by all practical mechanics as being the best Geared Screw Chuck made. Furnished also with solid jaws, non-reversible, either inside or outside bites.



We put up the same style Chucks, both Three and Four Jaws, *without the Combination Attachment*. With this exception it is practically the same chuck as our Combination, thus making a first-class *Universal* Chuck. The jaws are ground *perfectly true on face and bite, after being hardened*.

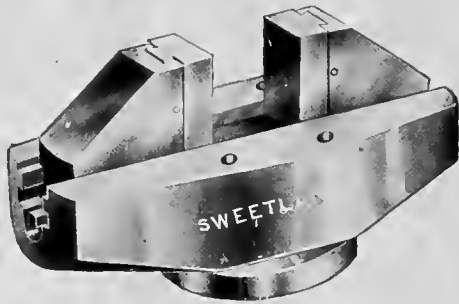

THE SWEETLAND BOX BODY CHUCKS

With Soft Steel Slip Jaws

Tool Steel and Soft Metal Slips, or Special Jaws of any kind can be furnished when required.

Furnished either as Universal or Independent as desired. In the Universal the hole through the Chuck is, of course, obstructed by the screw which operates the jaw.

HAND CUT STEEL LETTERS, FIGURES, STAMPS AND MARKING ROLLS

LETTERS AND FIGURES



The proper grade of steel is used in the construction of these hand cut steel figures and letters. A size suitable for the letter to go on it is used, and is long enough so it can be held without hitting the fingers.

HAND CUT STEEL STAMPS

Of all kinds and for all purposes. The work is all strictly hand cut, the letters being correctly shaped and the stamps properly tempered to suit the work they are to do.

THE FOSS & HILL MACHINERY COMPANY

MONTREAL

Mention this paper when writing advertisers. It will identify the proposition about which you require information.

The FOSS & HILL MACHINERY Co.

305 ST. JAMES ST., MONTREAL, QUE.

Sweetland Independent Lathe Chucks

Iron and Steel

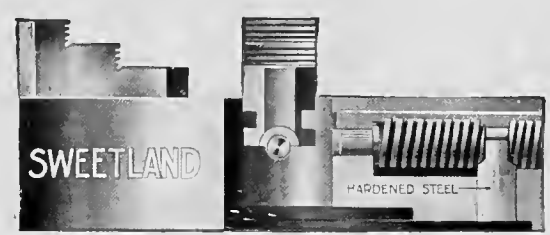
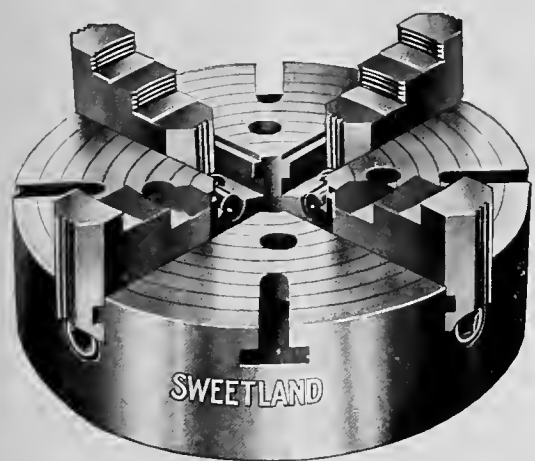

Body neatly designed, strongly built and properly balanced. Maximum strength with minimum weight. Hardened steel bearings, screws, large and well made, of a special grade of steel, flush with body of chuck.

Jaws of a good grade of steel, properly hardened. Gripping and bearing surfaces ground perfectly true, reversible.

The Sweetland Geared Scroll Chucks

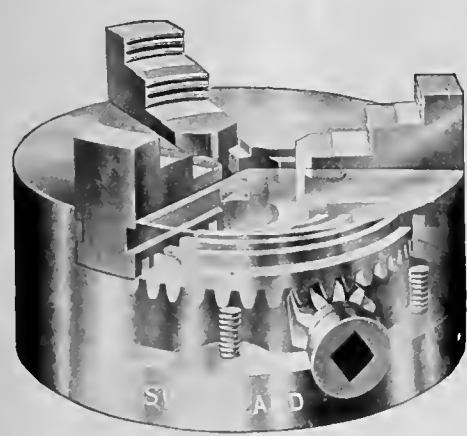

This Chuck is made in sizes 2 1/2" to 18" diam., both with Three and Four Jaws. When so ordered it is supplied with Solid Reversible Jaws, two sets in one. A unique feature in a Scroll chuck.

It is also fitted with non-reversible inside or outside Jaws, or with both sets, as may be specified. Material and workmanship throughout are of the best. The jaws are ground perfectly true on face and bite, after being hardened.

THE FOSS & HILL MACHINERY COMPANY
MONTREAL

If any advertisement interests you, tear it out now and place with letters to be answered.

The FOSS & HILL MACHINERY Co.

305 ST. JAMES ST., MONTREAL, QUE.

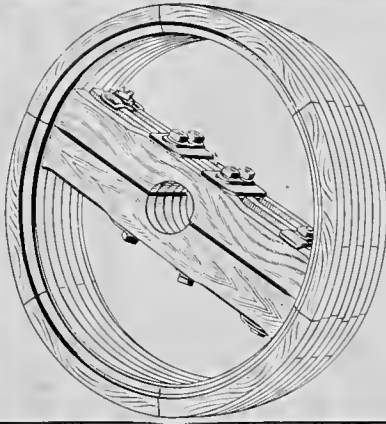

Selling Fast on Its Merits—

This pulley was but recently placed on the market, and we are receiving repeat orders galore. Its popularity proves that we are not alone in the conviction the Bernard Wood Split Pulley lead in quality, appearance and finish.

Give it a trial, it's sure to appeal to you.
Prices and full particulars on application.

*The Bernard
Wood Split
Pulley*

The A. Bernard Industrial Company

Manufacturers of High-Grade Power Transmission Appliances
Office and Works: FORTIERVILLE, QUE., CANADA

When in the Market for MACHINE TOOLS OR SUPPLIES

Don't forget to get quotations from

THE FOSS & HILL MACHINERY COMPANY

305 St. James Street, Montreal, Que.

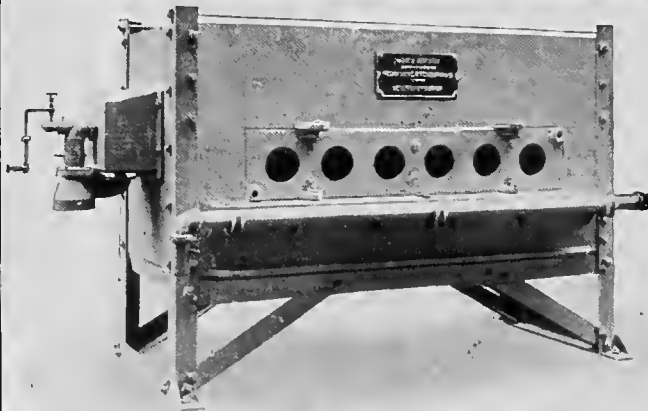

“MECOL”

6" Shell End Nosing
Furnace

*We manufacture furnaces for all
purposes to be used with
any kind of fuel*

The Mechanical Engineering Company, Ltd.

THREE RIVERS, QUE., CANADA



Figure 1850.

Plenty of Coolant at Slow Speed

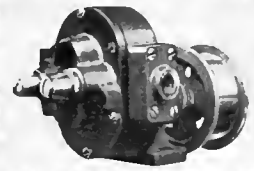

Figure 1851.

TRAHERN ROTARY GEARED PUMPS can be operated at slow speed and yet furnish the desired amount of coolant—this is not possible with a centrifugal pump, which must be run at terrific speed to supply enough lubricant to the cutting tool. This naturally shortens life of the pump. With TRAHERN positive drive you can force sufficient lubricant through discharge to reach deep bores or other work difficult to cool—an accomplishment peculiar to the geared type. These are but some of the reasons why such machine tool manufacturers as The Gleason Works, Gisholt Machine Co., etc., are equipping their machines with TRAHERN product. We want to tell you all about them.

Figure 2356.

Send this page with your address noted on it and we will.

Figure 2357.

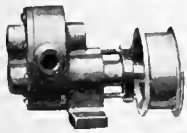

TRAHERN PUMP COMPANY, Rockford, Illinois
 Canadian Agents: **A. R. Williams Co., Toronto**

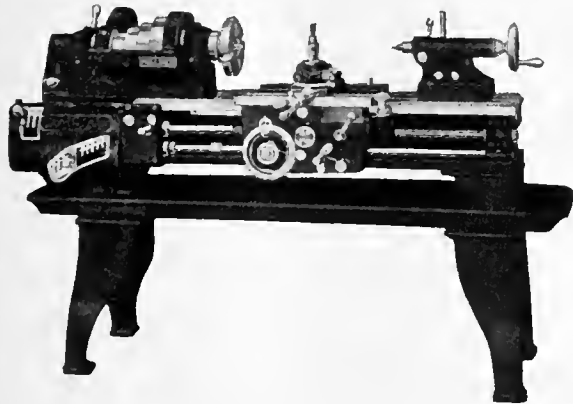
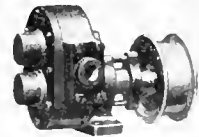

Mulliner-Enlund Tool Co.
 SYRACUSE (INC.) N.Y.

REPRESENTATIVES:

- | | | |
|-----------------------------------|---------|------------------------------|
| Carpenter & Woodward | - - - - | New York City |
| D. Nast Machinery Company | - - - - | Philadelphia, Pa. |
| Homer-Strong, Inc. | - - - - | Rochester, N.Y. |
| Lynd-Farquhar Company | - - - - | Boston, Mass. |
| Somers, Fidler & Todd Company | - - - - | Pittsburgh, Pa. |
| H. W. Petrie, Ltd. | - - - - | Toronto, Ontario |
| The Foss & Hill Machinery Company | - - - - | Montreal, Quebec |
| Richard Henriksen | - - - - | Petrograd, Russia |
| Patterson Tool & Supply Co. | - - - - | Dayton, Ohio |
| Strong, Carlisle & Hammond Co. | - - - - | Cleveland, Detroit, Michigan |

37 Threads and Feeds

This range is easily obtained by a quick change mechanism mounted on the front of the lathe, simply manipulate a sliding tumbler in connection with the compounding lever. The cone gears are cut with 20 degree pressure angle cutters forming a pointed tooth slightly rounded at the top. This permits instant engagement without clashing. Double walled apron, giving double bearings to all studs.

These are just a few of many features that go to stamp this lathe with quality.

Get in touch with our agents. We will gladly give you any desired information.

If any advertisement interests you, tear it out now and place with letters to be answered.

Copy by Photography The Quick—Cheap— Errorless Way

WITH THE

PHOTOSTAT

(TRADE MARK REGISTERED)

OFFICES use it to copy checks, vouchers, reports, cost sheets, statements and accountings. One firm uses it to copy involved sales contracts containing sketches; another to duplicate testimonial letters.

MANUFACTURERS to copy blue prints, shop orders, tracings, contracts, drawings and illustrations for salesmen; cuts and drawings for patent work; to prepare engravings for booklets and circulars.

PUBLIC SERVICE corporations are using it to copy reports for directors, trustee accountings, insurance papers, tariffs, complicated papers of every sort that heretofore involved heavy copying expense.

Railroads use it to meet the Federal Valuation Act requirements for certified copies of important papers, and for copying way bills, claims, traffic reports, conductors' sheets, and countless routine papers.

The range of work that can be done by the PHOTOSTAT is almost unlimited; it copies by photographing directly on paper or cloth, anything or everything, drawn, written or printed; also hand tools and machine parts; in a few minutes at a cost of a few cents.

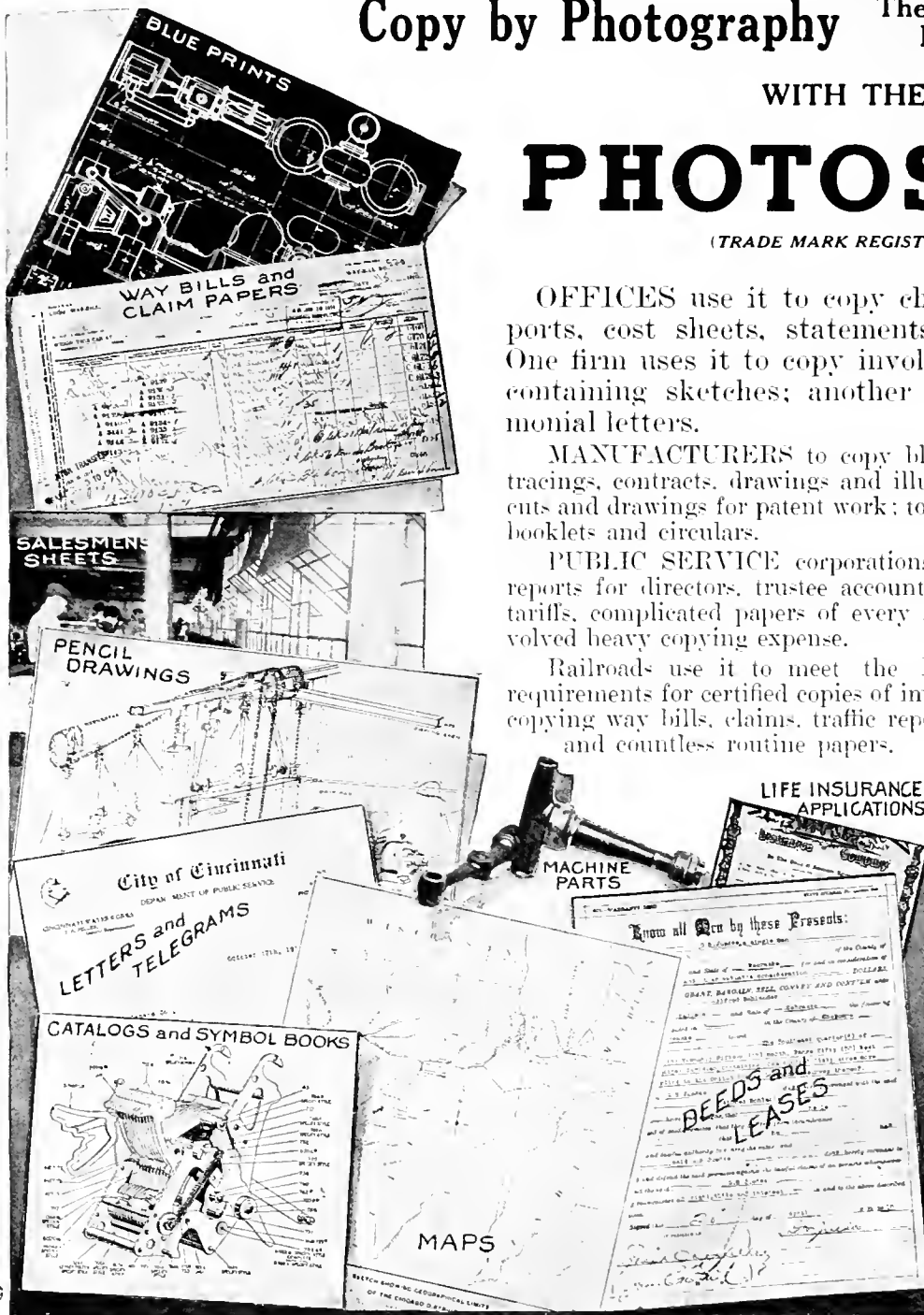

No expert knowledge required. All processes are mechanical. Hundreds of PHOTOSTATS in daily use testify to the value of the PHOTOSTAT.

Manufactured by the Eastman Kodak Co., for the

Commercial Camera Co.

343 State St., Rochester, N. Y. 325 Grosvenor Bldg., Providence, R. I.

ALBERT HERBERT, Agents, Coventry, England

Write for the PHOTOSTAT Book



The PHOTOSTAT in Operation

Mention this paper when writing advertisers. It will identify the proposition about which you require information.

The Sun Never Sets on HOYT METALS

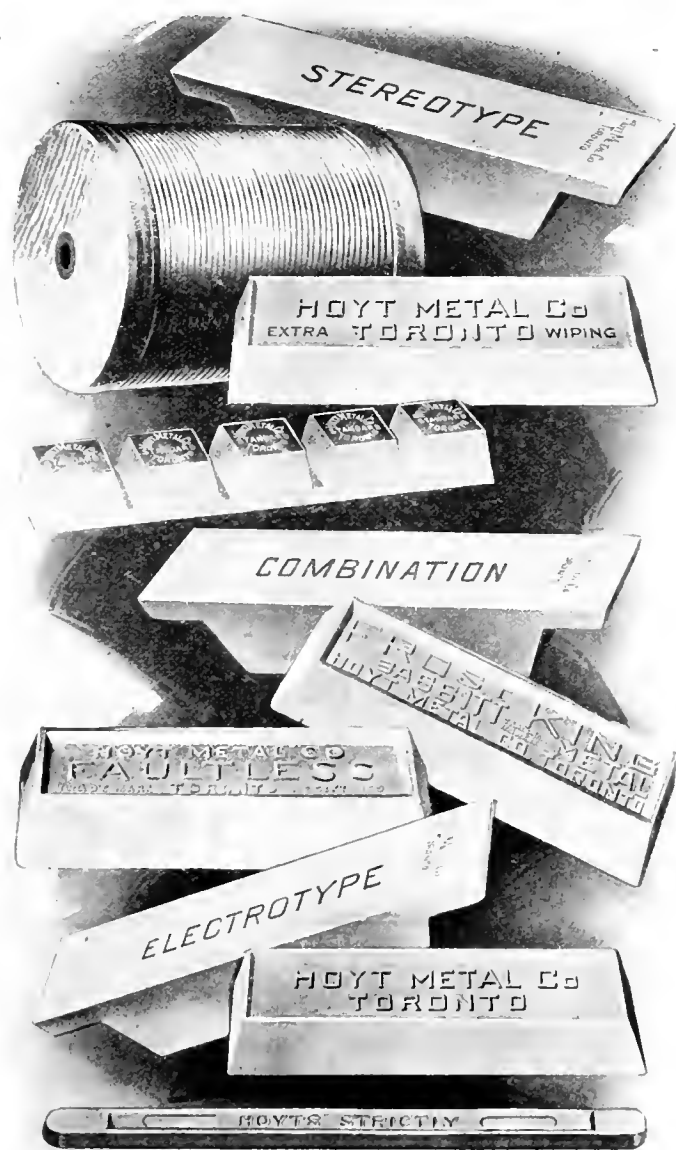

Sold all over the World on Their Merits

The fact that the Hoyt Metal Company manufactures over five million dollars' worth of mixed metals annually is conclusive argument for the superiority of Hoyt Alloys. Perfect alloys, prompt attention, and courteous service are the three reasons why our Company has developed the largest mixed metal business in the world in a little over 40 years.

Hoyt Alloys are sold all over the civilized world. If you want quality, satisfaction, and contentment in your plant, it is imperative that you use metal of our manufacture.

The Lines That Have Made
Hoyt Metals Famous

"Nickel Genuine"
"Trojan"
"Frost King"
Babbitts

Solders in Bar and Wire

Solders manufactured by us are free flowing and satisfactory in every way.

HOYT METAL COMPANY, EASTERN AVENUE and LEWIS STREET
New York, N.Y. London, Eng. Toronto, Canada St. Louis, Mo.

If any advertisement interests you, tear it out now and place with letters to be answered.

Heavy Base Facing Machine

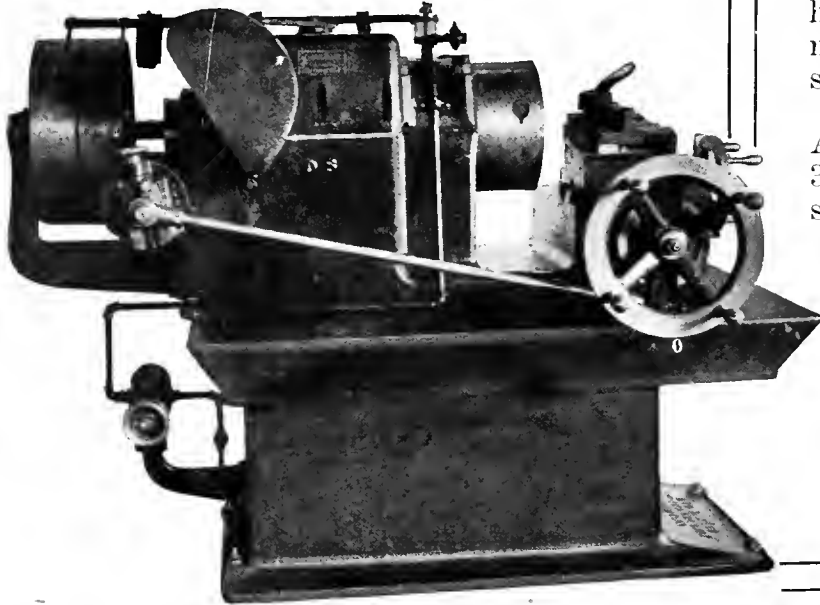

Takes Cut $1\frac{1}{4}$ Inches in
Width Off Base of
6-Inch Shell

This is one of those rapid, highly efficient shell machines that are helping the munition plants to meet the demand for accurate and speedy production.

All gears made of steel. Weight 3,600 lbs. Takes minimum floor space. No countershaft required.

We are well equipped to advise you on all shell problems.

WRITE TO-DAY.

Victoria Foundry
Company, Limited

OTTAWA

ONTARIO

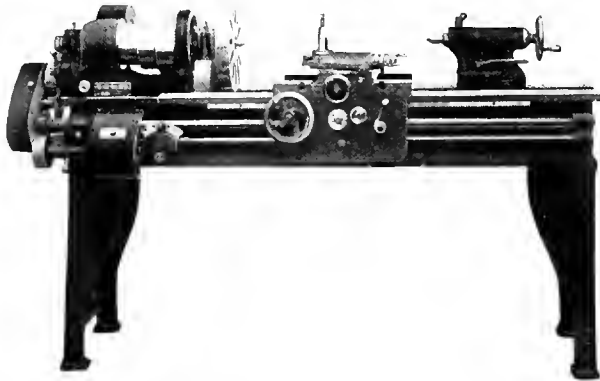

"Filsmith" 13" Lathe

A Machine whose design was specially made to make it proportionate throughout. Each individual part was made to conform to our standard, and as a result of these careful preparations we are offering an engine lathe that is decidedly individual in its quality. An inquiry will be answered speedily with specifications, etc.

The Phillip Smith Mfg. Co.
Sidney Ohio U.S.A.

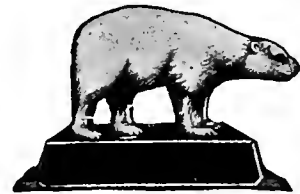

Brass, Phosphor Bronze, Copper and Aluminum CASTINGS

We have the largest Jobbing
Brass Foundry in Canada.
Can make prompt delivery.

Tallman's reputation is in the goods.

Tallman Brass & Metal Co.
HAMILTON, ONT.

CANADA



The Value of a Clean-Cut Layout

Unless work is laid out accurately at the start, many difficulties will arise as the job progresses.

A confusion of faint lines may mean lost time and perhaps throwing away a valuable piece of metal.

It is important then that the lines be distinguished quickly, no matter how much they crisscross. The clean-cut lines made with a

Starrett Surface Gage

will greatly aid machinists in preparing a clean layout on which work can be done accurately. This useful instrument may be used to scribe on all kinds of surfaces and is very handy for transferring measurements for duplicating work.

Our free catalog No. 213 will tell you more about this surface gage, also describes 2,400 sizes and styles of measuring tools. Write for it to-day.



42-661

The L. S. Starrett Co.
The World's Greatest
Toolmakers
Athol, Mass.



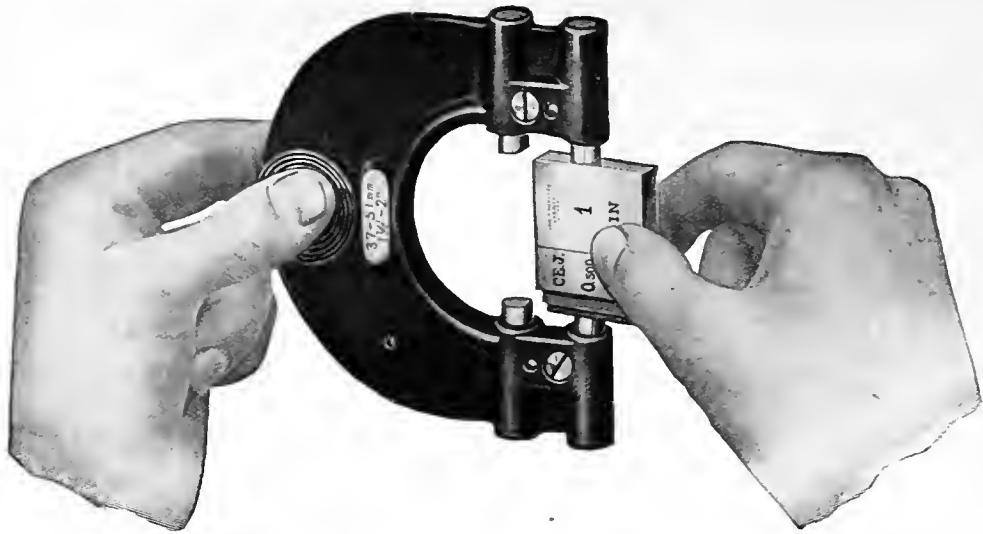

Tools That Increase Production

Two hands and ten fingers, to-day, can produce a great deal more than they could a thousand or even a hundred years ago. We all know why.

Science, taking form as machinery and tools, has multiplied the usefulness of our two hands. Modern tools and scientific methods give us greater power to help ourselves and to serve others.

A good tool appeals to the pride of every workman. It puts him on his mettle. It gives him a new sense of responsibility for first-class work.

THE JOHANSSON GAGING SYSTEM

Johansson Standard Gages are used in every civilized part of the world to originate sizes and establish limits. They are invaluable for setting and checking all kinds of gages and measuring tools. They simplify the work of laying out jigs and fixtures—thus saving valuable time. They reduce waste by preventing mistakes due to inaccuracy.

Johansson Adjustable Limit Shop Gages bring the limit system within the reach of all. With a "Johansson" limit gage, the operator

doesn't waste time *wondering* whether his work is right. He can test both limits at one touch without even turning his hand. Faster and easier work, with greater security that the product will be "just right."

Johansson Limit Gages are adjustable for wear, changing limits and different sizes. It would pay to compare the cost of "Johansson" equipment with the endless expense of making up and maintaining your own gages.

If you want to increase your production adopt Johansson Gages.

THE SWEDISH GAGE CO., Inc.

New Birks Building, MONTREAL, QUE.

Reduce Your Costs—Why Not?

Cost-cutting is Made Easy with the
30,000 R.P.M.



Portable Electric Grinder

Has a matchless combination of speed and efficiency assets and is bound to reduce cost of production wherever introduced. It is the acme of accuracy.

Armature, internal spindle, pulleys and emery wheels are dynamically balanced. No end thrust, no side play.

Motor and internal spindle are equipped with S K F and "Norma" Bearings—that's a big feature. There's no other grinder on the market as profitable as the ARO.

Write for full details.

R. E. T. Pringle, Limited
Manufacturers' Agents

OFFICES:

Tyrre'l Bldg., 95 King St. East, Toronto
809 Unity Bldg. - - - Montreal, Que.
3402 Osler Ave. - - - Vancouver, B. C.
302 Donalds Block - - - Winnipeg, Man.

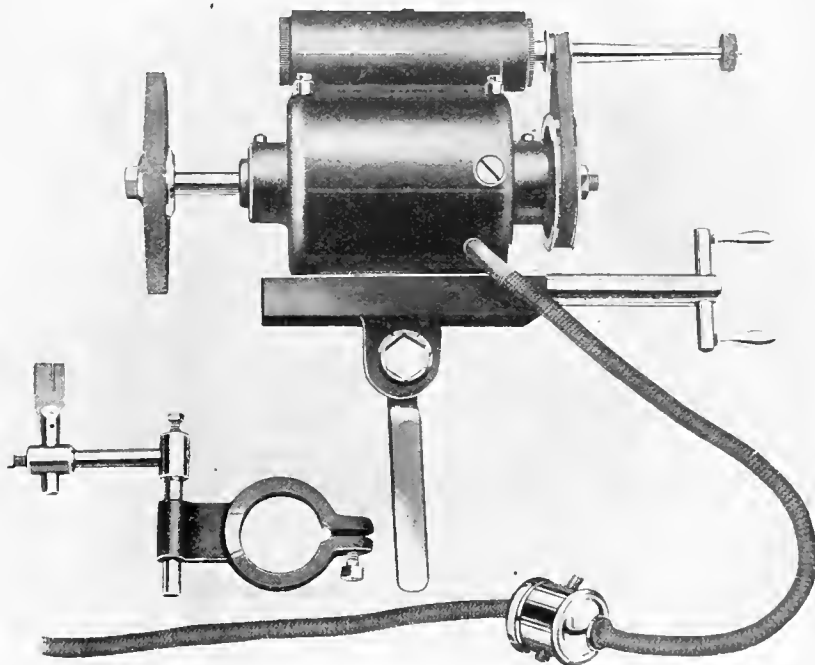

Threading Machines

Little Giant

threading machines are free from time-consuming complications. Any shop employee can set them up in a few minutes. They are very easily operated. Any length of thread can be cut with the power machines, as they are fitted with hollow spindles.

The Little Giant line includes a complete range from the power machines with Automatic Opening Die Heads to the small bench machines with Solid Die Heads.

Send for general catalog showing our complete line of Bolt Cutters, Taps, Dies, Screw Plates, Gages, Reamers, etc.

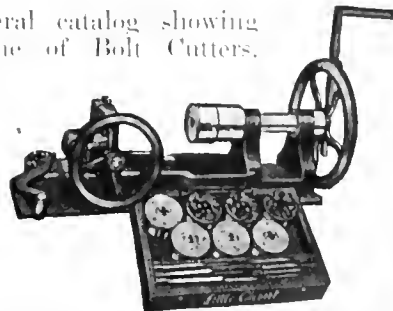
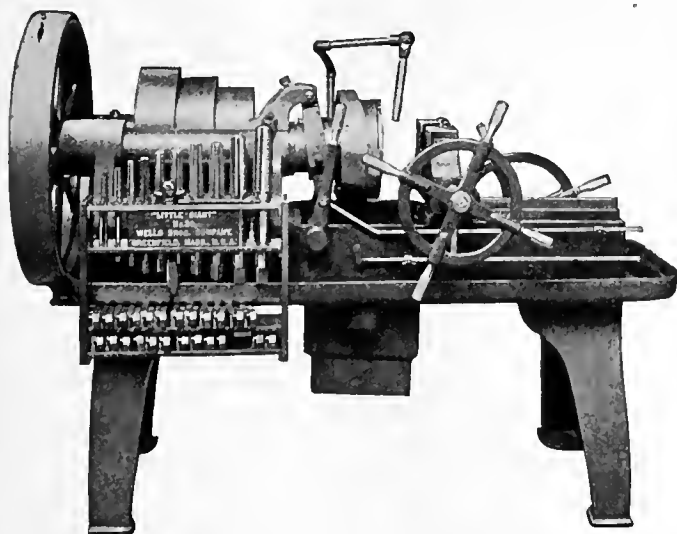

Wells Brothers Company of Canada, Limited

GALT :. ONTARIO

Sales Agents: THE CANADIAN FAIRBANKS-MORSE COMPANY, LIMITED
Montreal Toronto Vancouver Winnipeg St. John Calgary

If any advertisement interests you, tear it out now and place with letters to be answered.

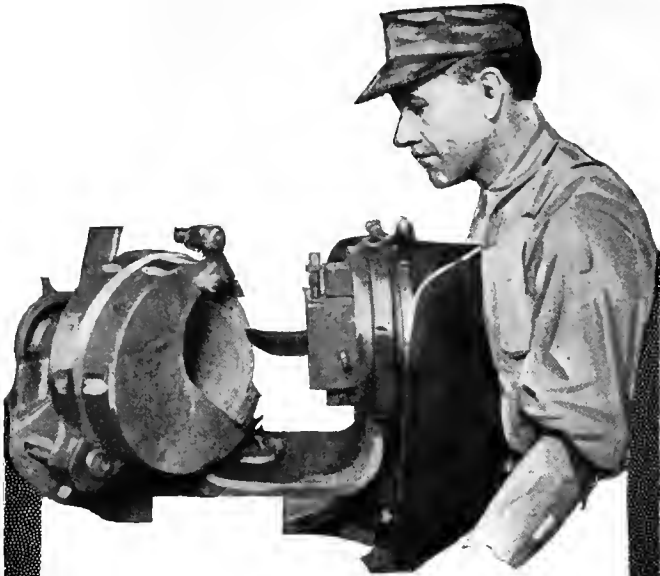

Alundum for High Speed Steel Tools

The grinding of high speed steel tools requires the use of a wide variety of wheels, each one the correct wheel for its purpose.

For offhand grinding the wheels range in grade from M to P and in grain from 20 to 80, according to the size of the wheel. The abrasive is exclusively Alundum and the process both Vitrified and Silicate.

For automatic machines, similar to that pictured above, the wheels usually supplied are listed below.

Gisholt		
20 M and N		Vitrified Alundum
Sellers No. 1		
20-24 L and M		Vitrified Alundum
20-24 L and M		Silicate Alundum
Sellers No. 2		
36 L		Vitrified Alundum
30 and 36 M		Silicate Alundum
Taylor		
24-0		Silicate Alundum



NORTON COMPANY
WORCESTER, MASS.

NEW YORK STORE
151 Chambers St.

CHICAGO STORE
11 N. Jefferson St.

Canadian Agents: The Canadian Fairbanks-Morse Co., Ltd., Montreal, Toronto, Ottawa, St. John, N.B.; Winnipeg, Calgary, Saskatoon, Vancouver, Victoria; F. H. Andrews & Son, Quebec, Que.

857 a

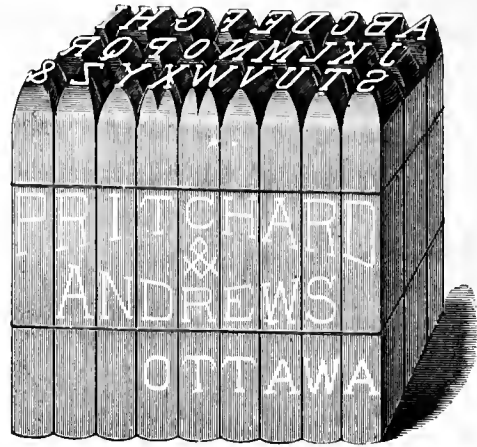

STEEL STAMPS

FOR MARKING SHELLS, ETC.

We will Give You Satisfaction on All Work of this Kind

SEND FOR PRICES

Pritchard-Andrews Co., of Ottawa

General Engravers and Die Sinkers

264 SPARKS ST.

OTTAWA, CANADA

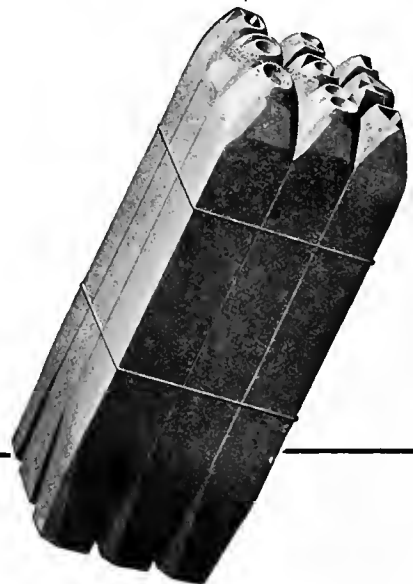

Are You Satisfied

With the Steel Stamps You Are Using?

The Pannier Bevel Hand-made Steel Stamps "Stand the Stamping," our customers tell us.

Complete Catalogue upon request.

PANNIER BROS. STAMP CO.

Pittsburgh, Pa., U. S. A.

The Finishing Touch to a Good Product is the Maker's Name or Trade Mark

Every product offered for sale is the concrete expression of character, the crystallization of the thought and labor of one man or a group of men. The more widely it is known the greater will be its success. The more clearly it is differentiated from similar products, the surer it is to maintain its eminence.

Therefore, mark what you make. Mark it so there can be no doubt as to where, or by whom it is made; mark it in order to protect the buyer as well as yourself—and let Matthews of Pittsburgh furnish the device with which to stamp it.

Matthews-made letters, figures, symbols, etc., are distinctive. They embody the best materials and the most highly skilled workmanship. They have been a specialized product for 67 years. They are used in industries of all kinds, from stamping logs in lumber camps to marking shells in munitions plants.

Matthews makes marking devices of every cost ranging from tiny rubber stamps to heavy steel lettering dies and furnishes special designs for individual requirements. Catalogue of Steel Lettering Dies and Stamps on request.

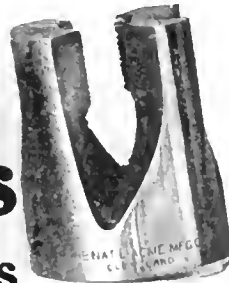
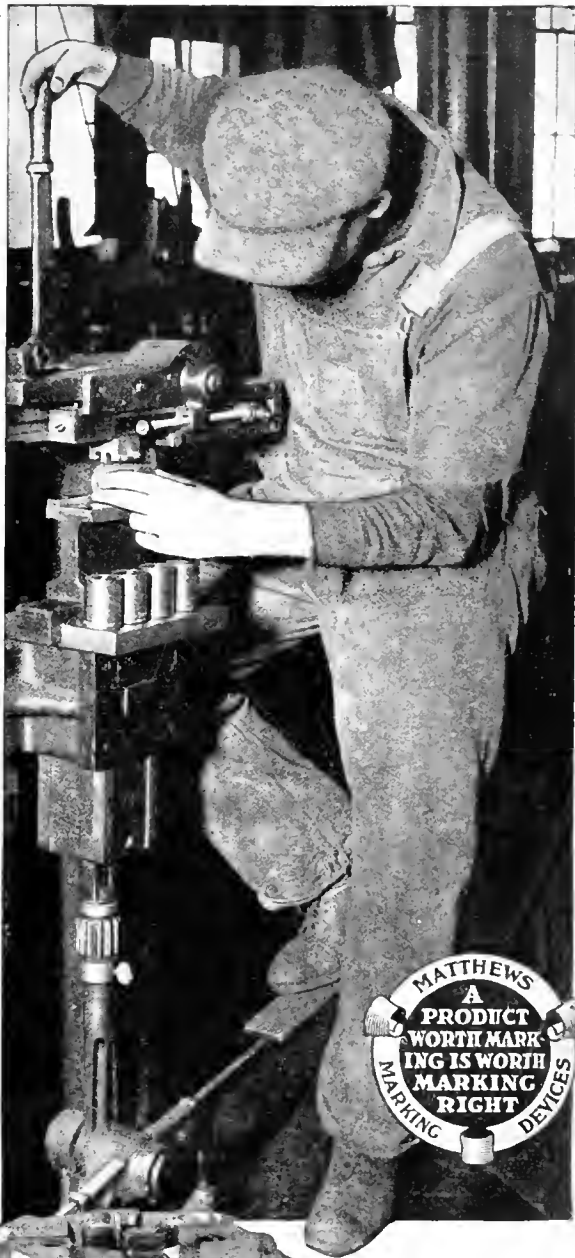

Stamped with

Matthews Marking Devices

JAS. H. MATTHEWS & COMPANY PITTSBURGH, PENNSYLVANIA 67 Years in Business

Distributors for Canada: THE CANADIAN FAIRBANKS MORSE CO.

Montreal St. John Toronto Winnipeg Calgary Vancouver Ottawa Quebec Saskatoon Victoria

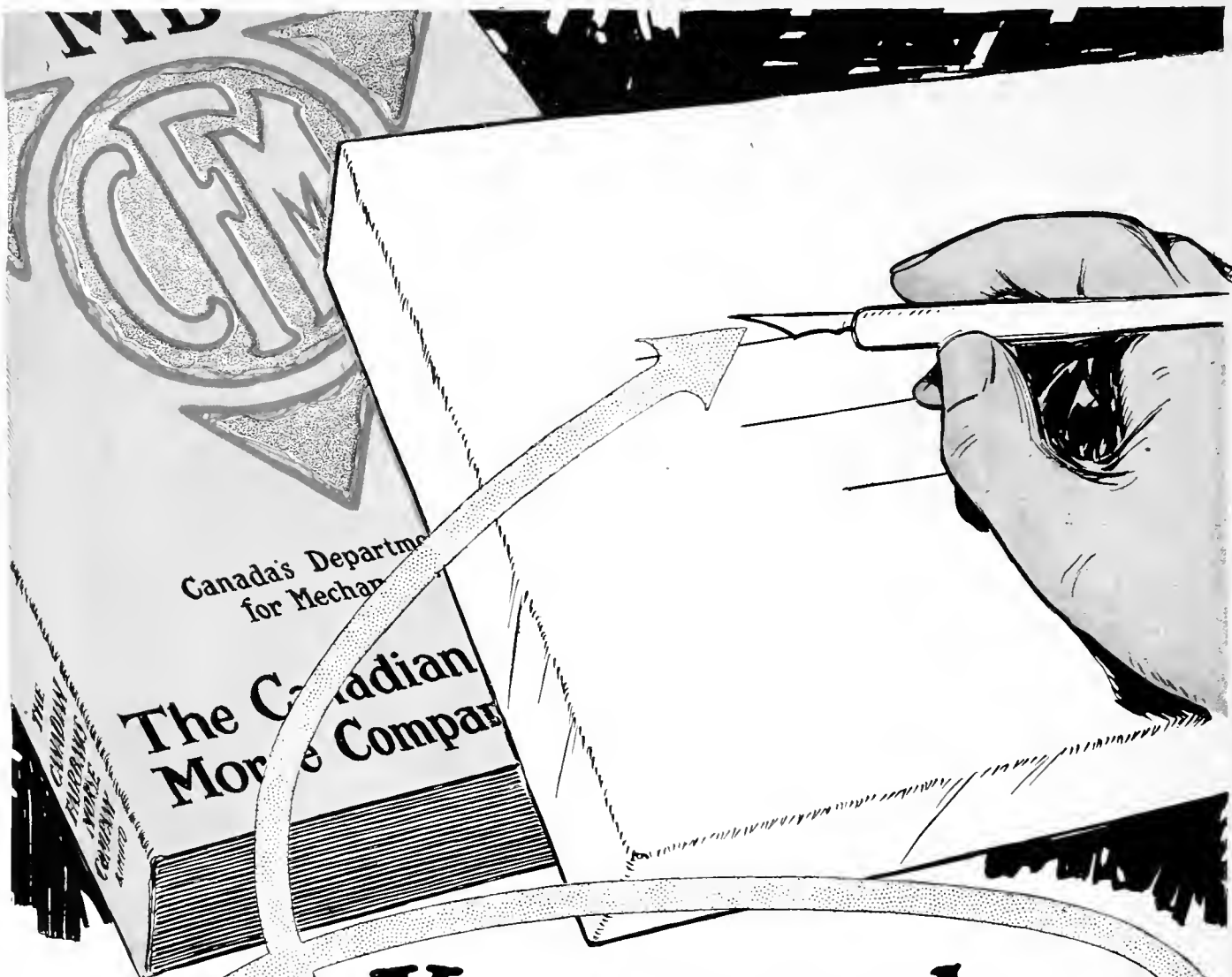

Your name here

Will bring you free a copy of our new catalogue The F.-M. Book.

A book of over—1000 pages a veritable encyclopedia of mechanical goods.

It contains a very complete line of Fairbanks Scales—Fairbanks Valves—Steam goods of all kinds—Fairbanks-Morse Oil Engines—Automobile & Motor Boat Accessories—Fairbanks-Morse Electrical Machinery—Pumps of all kinds—Machine Tools—Transmission Appliances—Railway & Contractors Supplies Small Tools & Machine Shop Supplies.

Address our nearest warehouse

The Canadian Fairbanks-Morse Co., Limited

ST. JOHN, QUEBEC, MONTREAL, OTTAWA, TORONTO, HAMILTON,
WINDSOR, WINNIPEG, SASKATOON, CAGARY,
VANCOUVER, VICTORIA.

Clip and Mail Coupon

The Canadian Fairbanks-Morse Co., LIMITED

Send me your C. F.-M. Book containing a full line of Mechanical goods.
Add my name to your permanent mailing list—free

Name _____

Street _____

City and Province _____

CANADIAN MACHINERY AND MANUFACTURING NEWS

A weekly newspaper devoted to the machinery and manufacturing interests.

Vol. XVII.

TORONTO, JUNE 28, 1917

No. 26

EDITORIAL CONTENTS

Fifty Years of Business Expansion	671-675
General	675-676
Shipbuilding in Canada....Coal Situation Improving.	
Evolution and Revolution in Machine Shop Practice	677-682
Canada's Machine Tool Industry in Retrospect	683-697
General	697
Method in Makeshifts....Open Letter to the Kaiser.	
Production Methods and Devices	698-700
Milling Twelve Sides on Large Disc....Eye-Strain Among Draftsmen....Machinists' Instruction Course —XXII.	
General	700
Foundrymen's Convention and Exhibition.	
Present Day Production of Metals and Minerals in Canada	701-703
General	703
Fire Losses Last Month....Car Shortage is Serious.	
Editorial Correspondence	704-706
Fundamentals of Efficiency....By-product Coking....The Aeroplane as a Means of Commercial Transport ..A Specific Instance of Specific Gravity....Removing Broken Set Screw.	
Design and Constructional Features of Turbine Pump	707-713
High Pressure Air Compressor Design and Application	714-719
Editorial	720
Fifty Years of Confederation....Manning Canadian-Built Merchant Ships.	
Industrial Notabilities	721
Lt.-Col. the Hon. Frederic Nicholls.	
Selected Market Quotations	722-723
The General Market Condition and Tende.....	723-724
Summary....Montreal Letter....Toronto Letter....Sydney Letter....Pittsburgh Letter.	
Industrial and Construction News	110-118

THE MACLEAN PUBLISHING COMPANY, LIMITED

JOHN BAYNE MACLEAN, Pres. H. T. HUNTER, Vice-pres. H. V. TYRRELL, Gen. Man.

Publishers of Hardware and Metal, The Financial Post, MacLean's Magazine, Farmer's Magazine, Canadian Grocer, Dry Goods Review, Men's Wear Review, Printer and Publisher, Bookseller and Stationer, Canadian Machinery and Manufacturing News, The Power House, The Sanitary Engineer, Canadian Foundryman, Marine Engineering of Canada.

Cable Address: Macpubco, Toronto; Atabek, London, Eng.

ESTABLISHED 1887

CANADIAN MACHINERY AND MANUFACTURING NEWS

PETER BAIN, M.E., Editor. B. G. NEWTON, Manager.
Associate Editors: A. G. WEBSTER, J. M. WILSON, J. H. RODGERS.

CHIEF OFFICES:

CANADA Montreal, Southam Building, 128 Bleury Street, Telephone 1004; Toronto, 143-153 University Ave., Telephone Main 7324; Winnipeg, 22 Royal Bank Building, Telephone Garry 2313.

GREAT BRITAIN LONDON, The MacLean Company of Great Britain, Limited, 88 Fleet Street, E.C., E. J. Dodd, Director, Telephone Central 12960. Cable Address: Atabek, London, England.

UNITED STATES New York, R. R. Huestis, Room 620, 111 Broadway, N.Y., Telephone Rector 8971; Boston, C. L. Morton, Room 733, Old South Building, Telephone Main 1204. A. H. Byrne, 1101-5-6-7 Fort Dearborn Bldg., 105 W. Monroe St., Chicago, Telephone Randolph 3236.

SUBSCRIPTION PRICE Canada, Great Britain, South Africa and the West Indies, \$3.00 a year, United States, \$3.50 a year; other countries, \$4.00 a year; Single Copies, 15 cents. Invariably in advance.

If there is one machine more than another where

Absolute Accuracy

is required, it is in the construction of an Experimental Lathe.

Accurate fitting, assembling, aligning of head and tailstock and carriage with lathe bed, is found without exception in the "Hendey."

Motor-driven. Besides regular equipment it has small tool cabinet for operators' fine tools—also gear closet for extra gears to cut special threads.

Let us tell you more about it.

The Hendey Machine Co.

Torrington, Conn., U.S.A.

Canadian Agents: A. R. Williams Machinery Co., Toronto, Ont.; A. R. Williams Machinery Co., 260 Princess St., Winnipeg; A. R. Williams Machinery Co., Vancouver; A. R. Williams Machinery Co., St. John, N.B.; Williams & Wilson, Montreal.



Hendey Experimental Lathe

12. Inch

INDEX TO ADVERTISERS—Continued from page 227

Montreal Machy. & Supplies	227
Morse Cham Co.	45
Morton Mfg. Co.	221
Mueller Mach. Tool Co.	54, 55
Muir, Wm., & Co.	145
Mulliner Enlund Tool Co.	73
Murphy Machine & Tool Co.	187

N

Napier Saw Works	238
National Machinery Co.	221
National Machine Tool Co.	259
New Britain Mach. Co.	25
New York Machinery Exchange	160
Nicholson File Co.	192
Niles-Bement-Pond	Inside front cover
Northern Crane Works	207
Norton, Ltd., A. O.	208
Norton Co.	80
Nova Scotia Steel & Coal Co.	18

O

Oven Equipment & Mfg. Co.	178
Osborn (Canada) Ltd., Saml.	5

P

Pannier Bros. Stamp Co.	89
Parmenter & Bulloch Co.	228
Perrin, Wm. R.	37
Peerless Machine Co.	29
Petrie, Ltd., H. W.	151
Petrie of Montreal, Ltd., H. W.	151
Philadelphia Gear Works	162
Plessisville Foundry	148
Pool Hope File Mfg. Co.	23
Positive Clutch & Pulley Works	4

Pratt & Whitney	Inside front cover
Preston Woolworking Machy. Co.	215
Pringle Ltd., R. E. T.	79
Pritchard-Andrews Co., of Ottawa	80
Puro Sanitary Drink'g Fountain Co.	147

R

Racine Tool & Machine Co.	29, 61, 187
Richmond Mfg. Co.	179
Riverside Machy. Depot	154
Rivett Lathe & Grinder Co.	228
Rockford Drilling Mach. Co.	213
Rockwell Co., W. S.	268
Rockafson Machine & Tool Co.	21
Roper & Co., C. F.	47

S

Sadler & Haworth	171
Samuel, Benjamin & Co., M. & L.	49
Scott, F. H.	221
Sheldons, Ltd.	201
Sebastian Lathe Co.	228
Shuster Co., F. B.	207
Shore Instrument & Mfg. Co.	182
Sidney Tool Co.	56
Silver Mfg. Co.	208
Simmons Mach. Co.	169, 188
Skipper Chuck Co.	210
Sleeper & Hartley Co., Inc.	191
Smooth-On Mfg. Co.	40
Smart-Turner Mach. Co., Ltd.	199
Smith Mfg. Co., Phillip	76
Smith & Mills Co.	131
Standard Alloys Co.	11

Starrett Co., L. S.	77
Steele, Ltd., James	145
Steel Co. of Canada	3
Steeple, John, Co.	196
Stirk & Sons, John	145
Stocker-Rumby-Wachs Co.	156
Stow Mfg. Co.	189
Strelinger Co., Chas.	155
Strong-Kemnal & Nutt Co.	221
Swedish Steel & Importing Co.	13
Swedish Gage Co., Inc.	78

T

Tabor Mfg. Co.	209
Tallmann Brass & Metal Co.	76
Tate-Jones & Co., Inc.	173
Taylor & Fenn Co.	132
Taylor-Forbes Co.	154
Taylor Instrument Co.	174
Thwing Instrument Co.	175
Toledo Machine & Tool Co.	37
Toomey, Inc., Frank	158
Toronto Iron Works	207
Toronto Welding Co.	114
Traham Pump Co.	73

U

Union Drawn Steel Co.	210
Union Tool Chest Works	239

V

Vanadium Alloys Steel	33, 34
Victoria Foundry Co.	75

Victor Tool Co.	179
Vulcan Crucible Steel Co.	15

W

Walcott Lathe Co.	22
Walton Co.	179
Warner & Swasey Co.	38
Wellbome & Co.	210
Welland, Corporation of	169
Wells Bros. Co. of Canada	79
West Tire Setter Co.	35
Western Tool & Mfg. Co.	53
Wheel Truing Tool Co.	191
Whittaker & Co.	219
Whiting Foundry Equipment Co.	47
Whitcomb-Blaisdell Mach. Tool Co.	39
Whiton Mach. Co., D. E.	269
Wilkinson & Kompass	210
Williams, A. R., Machy. Co.	22, 131-138
Williams & Co., J. H.	Inside back cover
Wilson & Co., T. A.	208
Williams Tool Co.	153, 250
Windsor Mach. & Tool Works	32
Willmarch & Morman Co.	209
Winfield Elect. Welding Mach. Co.	135
Winnipeg Gear & Engineering Co.	162
Wisconsin Electric Co.	193
Worth Engineering Co.	144

Z

Zenith Coal & Steel Products Co.	210
----------------------------------	-----



50 YEARS OF BUSINESS EXPANSION*

BY
W. A. CRAICK**

There is here given in racy fashion, yet evidencing in the variety detail discussed considerable painstaking and scrupulous regard for developments in the period under review, to the end that as far as possible everything embraced by the article title, wide in scope as it happens to be, should get at least a passing reference. Speaking generally, the advances made in the spheres of Industry, Finance, Transportation and Insurance are prominently featured.

CANADA'S position at the close of the fiftieth year of Confederation is imposing only in so far as present day conditions are placed in contrast with those prevailing at the dawn of the Confederation era. Progress is at best a relative term, and to appreciate to the full the extent of this country's development, one must visualize the setting in which that development was commenced.

To all intents and purposes, the whole of Western Canada, with its far-flung population, its many fine cities, its thousands of miles of railway and its enormous agricultural production, must be eliminated from the canvas. It is true that by 1867 some ten thousand people had settled in the Red River Valley; that stragglers had penetrated even farther west. It is also true that the gold rush of the late fifties had poured population into the Fraser River Valley and that Victoria was already a fair-sized town. But these widely-separated settlements, on the prairies and at the Coast, were almost as distant from Eastern Canada in those days as Australia is to-day, and further, their business associations were entirely with the neighboring sections of the United States.

Canada in 1867

The picture of Canada in 1867 narrows, therefore, to the comparatively restricted limits to the older settled portions of the country—the narrow fringe of clearing along the St. Lawrence; the lake front counties of Ontario; the coast and river settlements of New Brunswick and the scattered towns and fishing villages of Nova Scotia. The wider vision of a great and prosperous West had not yet seized upon the minds of the people and their field of possible endeavor lay

no further off than the thickly wooded concessions of the back counties.

Though fairly well populated and supplied with the modern means of communication, the older sections of Quebec and Ontario were still in a comparatively crude and undeveloped condition. Even between Montreal and Toronto, then as now, the two foremost centres of population in Canada, the appearance of the country was anything but prepossessing. There remained much uncleared land. Many of the homes of the inhabitants were at best but miserable shanties. The people were poor; the children dirty and ragged; the cattle lean. Towns, which were quite as numerous as they are to-day, and in several cases nearly as large, were suffering from the after-effects of the Grand Trunk boom, and exhibited numerous unoccupied and delapidated buildings.

From Prescott to Ottawa, then the customary route to the Capital, the railway traversed what appeared to be a continuous pine swamp, wet, dismal and depressing. The Capital itself lay hidden away in the midst of green, unbroken forests, which closed in on the log houses and small villas lying on the outskirts of the embryo city.

To the rear of the counties fronting on the St. Lawrence and Lake Ontario, settlement was just getting under way at the time Confederation came into being. Railways were being promoted to tap the resources of Peterboro, Victoria, Simcoe, Grey and Bruce Counties, and settlers were arriving from the Old Country to people their solitudes. In fact, this particular section of Canada was going through an experience which has since been duplicated many times in the West.

The Government was devoting special attention to the settlement of the free grant lands in the Muskoka District. Ad-

vertising matter of the same brand as that which later lured thousands of immigrants to the prairies, told of the prospective wealth to be derived from the cultivation of the soil in this remote part of the province. In response to the appeal, population was penetrating as far north as Parry Sound on the shore of the Georgian Bay, while Bracebridge was thronged with newcomers.

Oil and Gold Booms

It was about this period, too, that the oil boom in Enniskillen Township and the gold boom at Madoc were absorbing public attention. The former attracted the curious from all parts of the country. To reach the oil fields, visitors had to leave the Sarnia branch of the Great Western at Wyoming and drive through the woods to Oil Springs. It was a trip, as described by travelers, full of spectacular interest. The great dark forest, traversed by a narrow plank road; the constant succession of carts coming and going with their barrels of oil; the derricks, oil tanks and engines scattered through the clearings, all presented a scene of strange and outlandish character. Oil Springs itself was a village of wooden hotels, thronged with speculators and hangers-on, who by their frenzied efforts to secure paying properties increased the popular interest in the district.

The Madoc gold finds were made in the year before Confederation and the rush to the mines in the spring of 1867 was one of the events of that momentous year. Prospectors in large numbers thronged to the new gold fields, from which so much was expected, and many miners, who had participated in the California and British Columbia rushes, made their way to the new Eldorado. Five lines of stages from Belleville to Madoc

*Also in MacLean's Magazine.

**Of MacLean Publishing Co. Staff.

were for a time insufficient to accommodate the crowd who sought access to the scene of the discovery.

These events, bulking largely in the popular imagination at the time, have long since dwindled into their proper proportions. The oil wells of Enniskillen have become a commonplace; the gold strikes at Madoc have sunk into insignificance. Reference has been made to them merely to illustrate how places which fifty years ago were on the very fringe of settlement and to reach which tedious journeys had to be made, are now left far in the rear by the tide of progress. The gold of Porcupine has long since eclipsed the gold of Madoc, and in Southern Alberta the oil prospector has been finding new fields for his investigations.

Lumbering

In various other respects conditions have changed in old Ontario and Quebec. Lumbering was a far more important industry fifty years ago than it is to-day. The Great Western Railway brought down from its Sarnia branch annually large quantities of oak timber. This wood was rafted at Hamilton and towed to Quebec for export to the Old Country. The Northern Railway carried to Toronto, and the Port Hope, Lindsay and Beaverton Railway hauled to Port Hope trainload after trainload of lumber for shipment by schooner across the lake. Cordwood was one of the commonest commodities of the day, and trainloads of it were a common sight on the railroads fifty years ago. It was used not only for heating and cooking, but it formed the universal fuel for locomotives, and from the back settlements thousands of cords were shipped annually to the United States.

Early City Settlements

The extent of settlement in 1867 was reflected in the cities. To-day there are in the Dominion six cities with populations in excess of 100,000—Montreal, Toronto, Winnipeg, Ottawa, Hamilton, and Quebec—while a seventh, Vancouver,

falls little short of that figure. In the year of Confederation, however, Montreal was the only urban centre that came within 50,000 of reaching the 100,000 mark. Toronto could not boast 50,000 inhabitants. Winnipeg was a mere hamlet. Ottawa contained but 15,000 people. Hamilton just exceeded 20,000 by a narrow margin. As for those flourishing Western cities—Calgary, Edmonton, Regina, Saskatoon, Brandon, Moose

eration from a crude backwoods settlement into one of the finest cities in America. So unprepossessing was its appearance when it was selected by Queen Victoria to be the seat of government, that it was described as the Cinderella of Canadian Cities. Its intrinsic beauty was recognized, but that beauty was so hidden by uncouth and dirty surroundings that the comparison was by no means inapt.

Curious visitors who went to view the new capital during the early sixties, came away with mixed impressions. It was admitted that the site of the Parliament Buildings was a lovely one; that the surrounding forests had a wild impressiveness, and that the clear air, everlasting resounding with the noise of falling water, was exhilarating, but what were these natural attractions when everyday living conditions were so bad? The streets were rough, the houses mean and squalid, the hotel accommodation wretched, and the food poor. Lumber and sawdust littered the place until it looked like one vast timber yard.

A sister of Lord Monck, who visited the town shortly before the Governor-General moved there from Quebec, groaned over the prospects of life in such a place, describing it as "t'other end of nowhere." And it is known that civil service employees, who had to forsake the comparative loveliness of Toronto, Montreal, or Quebec, for its early crudities, bemoaned their fate, while Ministers of the Crown took the earliest opportunity to escape from its impenetrable dullness.

Of course, all this has changed. Ottawa to-day boasts the possession of every modern facility, not only for the enjoyment, but for the improvement of life. Its beautiful streets and parks, its splendid public buildings, its superior hotels—all these combine to render the contrast with the miserable, down-at-the-heel settlement of fifty years ago most striking and complete.

And what of other cities? Montreal,

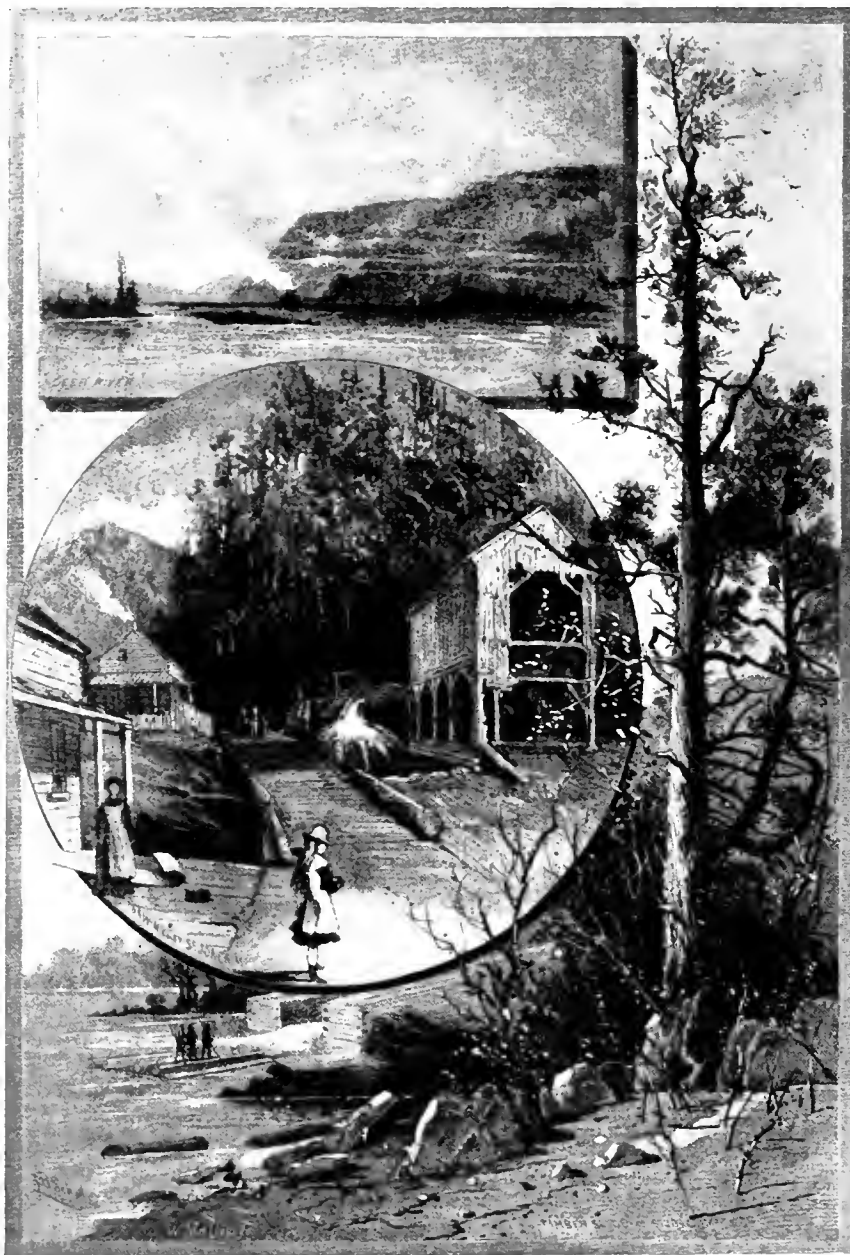

LUMBERING ON THE UPPER OTTAWA. A FLOURISHING INDUSTRY AT THE TIME OF CONFEDERATION.

Jaw, and Vancouver—they were practically all non-existent. Only conservative old burghs like Quebec, Halifax, and St. John, had populations in any way commensurable with present figures.

Our Capital City

The beautiful capital city of the Dominion, whose natural charms have been greatly enhanced by the work of the Ottawa Improvement Commission, has developed during the fifty years of Confed-

the foremost city of the Dominion with its more than 600,000 people could, in 1867, muster barely one-sixth of that number. In extent it was very considerably smaller. Its principal business thoroughfare of to-day, St. Catherine Street, lay on the outskirts of the city. Even lordly St. James Street, with its splendid financial institutions, was only just in course of construction. Business centred in Notre Dame Street; McGill College stood out in the suburbs, and it was a mile walk from the edge of the city to the mountain.

In several respects, Montreal, fifty years ago, was greatly inferior to the present city. Its streets were notoriously filthy, especially along the docks where the mud frequently lay knee-deep. The lighting even of the main thoroughfares was inadequate, gas being then the universal illuminant. The drainage was bad, and in this connection one visitor tells of having to leave the Theatre Royal one night in the middle of an amusing comedy on account of the vile odors that were wafted in through the windows. Apart from these deficiencies, however, the city seems to have been an imposing place with its solid-looking buildings, its many fine churches and its active commerce.

Our Queen City

Toronto's expansion during the fifty years has been equally, even if not more, phenomenal. When it is recalled that in 1867 Queen's Park, now in the heart of the city, was on its extreme northern edge, Trinity College was situated a mile beyond the western limits and that troops were able to go through extensive evolutions on a great common that lay between the city and Spadina Avenue, some faint conception of the physical growth of the place can be obtained. In population it has increased twelve-fold, or roughly from 40,000 to 480,000.

The cities in the east, Halifax and St. John, have probably exhibited fewer changes than their western sisters. Halifax, which has now about 50,000 inhabitants, had a population of 30,000 at the time of Confederation. St. John, which to-day contains approximately 54,000 people, was then a place of 35,000 inhabitants. In Halifax the lives of the citizens revolved around the garrison of British regulars which manned its forts and citadel. Some trading, it is true, went on with the West Indies. Fish was exported; sugar and other tropical products imported. But the military and naval interests of the place predominated and trade and commerce, while a necessary evil, were not allowed to thrust themselves too far into the foreground.

The commercial spirit was more in evidence in St. John, a city which then as now regarded its Nova Scotia contemporary with a feeling of suspicion and rivalry. St. John had been a notable shipbuilding centre for years and, not only was many a stout vessel built each year in its shipyards, but its merchants owned and outfitted numerous deep sea craft for service on the seven seas. The docks of St. John were a busy spot in those days, for ships and sailors were

numerous and there was a constant coming and going of vessels from distant ports.

Industries Feature

If cities were small fifty years ago, so also were the industries that flourished in them. Industrially, there has been a remarkable change in Canada during the past half-century. When Confederation came into being the settled sections of the country were plentifully supplied with an immense number of small steel industries. Each town, each village, had its little group of manufacturing establishments which produced the essentials of life for the people of the immediate neighborhood. A flour and grist mill, a sawmill, a tannery, a carding and fulling mill, a carriage factory and not infrequently a brewery or distillery were the possession of practically every centre of population.

The census of 1861 showed that in Ontario alone there were in operation 501 flour and grist mills, 1,164 sawmills, 271 tanneries, 185 carriage factories, and 143 breweries and distilleries. In Ontario, Quebec, New Brunswick, Nova Scotia and Prince Edward Island combined, there were 8,503 industries, of which 1,785 were flour and grist mills, 4,240 sawmills, and 710 tanneries. By 1867 all these figures had probably been considerably increased.

Few of these primitive local industries have survived the evolution of the centralized factory system. Here and there through the country there may remain some pathetic examples of these once important institutions. But, generally speaking, the economies introduced in the operation of the large factories of to-day have made it quite impossible for the small industry to exist.

Lachine Canal an Industrial Factor

Even in the sixties there were evidences of the development of large-scale manufacturing. The building of the Lachine Canal seems to have produced a considerable industrial boom in Montreal. The canal furnished four million horsepower of hydraulic energy per annum, a huge figure for those days, and, as practically all manufacturing was done by waterpower, manufacturers naturally flocked to this new source of energy.

The extent and importance of the factories along the canal filled visitors with astonishment. There were huge iron works, employing no fewer than 120 men and producing 12 tons of nail plates per day! There was a wonderful new flour mill, which could grind 500 bbls. of flour in twenty-four hours. There was a sugar refinery with a capacity adequate to manufacture seven-eighths of the sugar consumed in Canada and there was a marine works, which could produce several ships for river and lake service each season.

One may smile at the expressions of amazement with which the citizens of 1867 regarded these examples of industrial enterprise, the size and output of which have long since been eclipsed by

immensely larger establishments, but, after all, there were some industries in operation fifty years ago which would astonish even the wonder-sated folk of the twentieth century. The sawmills at Ottawa, for instance, were undoubtedly marvels. There were ten of them running night and day in an endeavor to keep pace with the efforts of the ten thousand lumbermen who were busy felling the forests along the river. One of these mills boasted eighty saws and the others were very little smaller. The ten mills together turned out 180,000,000 feet of lumber a year, while 16,000,000 cubic feet of square timber was rafted to Quebec each season for shipment across the Atlantic. In that golden age of the lumber trade, it took 800 ships, manned by 25,000 men, to carry the harvest of the Ottawa from Quebec to England.

Wood Shipbuilding

These were great and picturesque enterprises and so, too, was the wooden shipbuilding industry, which was in its heyday of prosperity when Confederation came into being. At Quebec and at many a harbor and port on the coasts of New Brunswick and Nova Scotia, fine, large wooden vessels were built and launched annually in considerable numbers. There were fifteen shipyards at Quebec alone, in which from 25 to 50 ships were turned out each year. Unfortunately, except for a forced revival of the industry at the present time, wooden shipbuilding is dead and thus an interesting chapter in Canadian industrial history is closed.

However, all industry in Canada in and about the year of Confederation was not so spectacular, though to the people of the time many of the developments seemed very wonderful. In Hamilton, for instance, where foundations for future industrial greatness were even then being laid, it was deemed a remarkable feat on the part of the local manufacturers to have installed \$100,000 worth of new machinery in a single year. The production of locomotives at Kingston was considered a work little short of marvellous. The erection in Sherbrooke in 1866 of a woollen factory five stories high was heralded as a most important event, while Victor Cote's new tannery at St. Hyacinthe, which gave employment to 90 hands, was regarded as a mammoth plant.

But if industries were small and scattered, the products of industry were by no means inferior. At the great Paris Exhibition in 1867, the goods of Canadian manufacturers showed to advantage. Furniture made by Jacques and Hay in Toronto was declared to be superior to anything on display. The wall hangings of the Stauntons compared favorably with the product of the English makers. The Barbers, of Streetsville, showed cloths and woollens of most creditable quality. Implements from the Jones plant at Gananoque and the Whiting plant at Oshawa, were highly commended, as were also the cigars exhibited by Davis, of Montreal.

Transportation Developments

Industrially, Canada has traveled far since those far-away days. All the mar-

velous expansion which the introduction of electricity has facilitated has come since then. The mammoth textile works with their electric drives; the great steel plants; the huge paper mills; all these and many more have sprung into being since 1867, and in no respect has the progress of Canada been more marked than in this department of national life.

Hand in hand with the growth of industry has gone the extension of transportation facilities and rapid means of communication. In 1867 the railway systems of the country, since expanded into transcontinental proportions, were limited in scope. This was especially true of the Maritime Provinces, where the stage coach was still an established and very necessary institution when the Confederation era dawned. Nova Scotia was served by two short lines of road, running from Halifax to Truro and from Halifax to Windsor respectively, a matter of some hundred miles of track in all. New Brunswick likewise had but two railways, one connecting St. John and Shediac and the other St. Andrew's and Woodstock. Prince Edward Island, which has now a system of 275 miles, was without any railway at all. In short, the three Maritime Provinces among them had only about 300 miles of road in operation, whereas today their mileage extends to 3,668 miles.

The Upper Provinces were somewhat better served. The Grand Trunk, then the longest railway in the world under one management, ran from Portland, in Maine, to Sarnia, in Ontario, and from Riviere du Loup, on the Lower St. Lawrence, to Richmond, P.Q. Its most formidable rival was the Great Western, running from Niagara Falls through Hamilton, to Windsor, with a branch from Hamilton to Toronto. Northward stretched lines from Prescott and Brockville to Ottawa, from Port Hope to Bea-

verton, and from Toronto to Collingwood. All the rest of the network of roads now traversing both old and New Ontario were non-existent.

Railroad Through Traffic

The idea of through traffic was only just being evolved in 1867. The Great Western, then a wide-gauge road, as were most of the railways in Canada, had laid a third rail from Windsor to Niagara Falls and built a car ferry for service across the Detroit River, in order to secure a slice of the business between

in this regard that they were receiving.

Communication between the Maritime Provinces and the Upper Provinces in those days was usually by coasting vessel from Halifax or St. John to Portland and thence by Grand Trunk to Montreal. The extension of the Halifax-Truro road to Pictou, completed in the Confederation year, gave a new summer route up the St. Lawrence to Quebec, while one of the fruits of the new political arrangements between the provinces was the establishment of a line of steamers to run from Montreal and Quebec to

Maritime Province ports. Otherwise it was possible to take a longer stage journey up the St. John valley from the railway terminus at Woodstock to Edmundston and across the height of land to Riviere du Loup, where the Grand Trunk terminated. This was the route by which the British regulars journeyed to Upper Canada at the time of the Fenian scare.

Victoria Tubular Bridge

The recent completion of the Victoria tubular bridge at Montreal was then filling the minds of visitors with awe and astonishment. It was hailed as one of the wonders of the world, a scientific achievement without a peer in the history of construction. Its three million cubic feet of masonry, its eight thousand tons of iron, its enormous length, its great cost, were dilated

upon in unmeasured terms of admiration. For the times it was indeed a remarkable engineering feat, but since then many a far more wonderful undertaking has been completed in Canada, which illustrates still further how the country has progressed.

Canada's canal system had by 1867 reached considerable proportions and comparatively speaking, traffic by water was of more importance than that it is to-day. The lakes were covered with sailing craft, while steamboats were far more numerous than they are now. Of

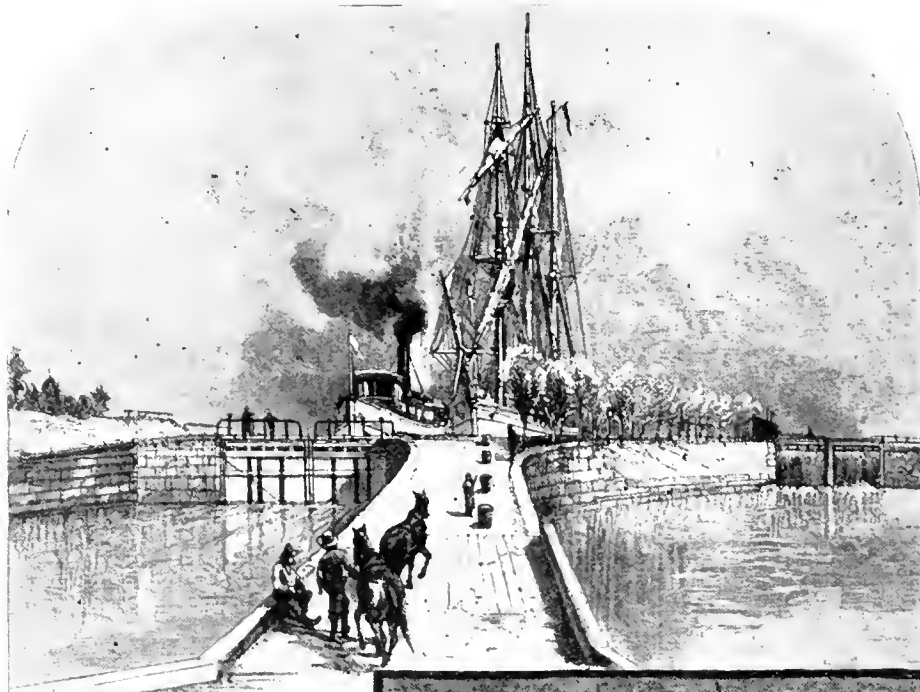

LOCK NO. 1, NEW WELLAND CANAL

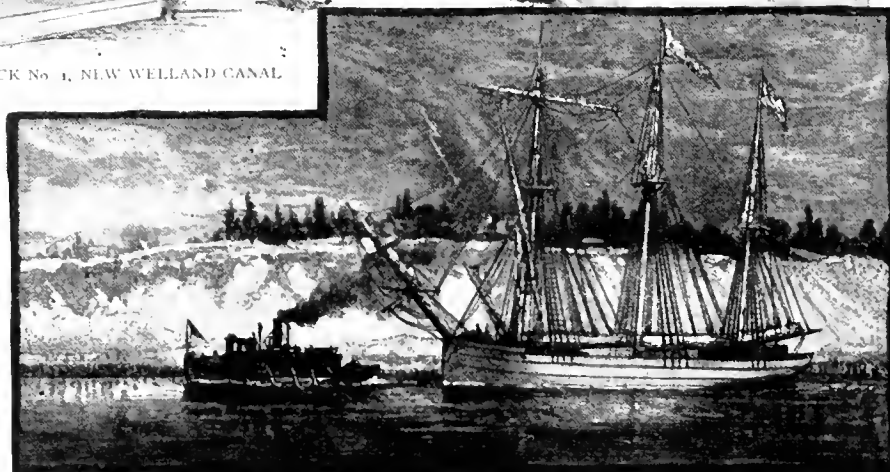

THE DEEP CUT. A VIEW OF THE WELLAND CANAL IN THE EARLY DAYS.

the newly developed settlements in the Middle West and the seaboard. The Northern Railway from Toronto to Collingwood was paying so much attention to the traffic it was receiving from the upper lakes and trans-shipping at Toronto for lower lake ports, that settlers along the line complained of the difficulty of getting their cordwood shipped to Toronto. In fact, the promoters of the Toronto & Nipissing and the Toronto, Grey & Bruce made it a point in soliciting financial aid from the municipalities that they would serve the settlers better

course, all these vessels were so much smaller than the big freighters of the twentieth century that mere numbers were insignificant. At the same time they provided a most picturesque element in the picture of Canada in 1867. The passage of fifty schooners a day through the Welland Canal was by no means an unusual experience in the year of Confederation.

The canals were much smaller than they are to-day. Those on the St. Lawrence, by means of which ships passed up from Montreal to Lake Ontario, contained but nine feet of water, while the locks were limited to 200 feet in length. Notwithstanding this, records of vessels are not uncommon which had sailed down from the upper lakes and, passing through these canals, had later crossed the Atlantic.

Conditions of Travel

Traveling conditions in the year of Confederation were none too satisfactory. As compared with the luxury of the present day, a journey even for a short distance was an arduous and uncomfortable undertaking. In the Maritime Provinces, if a traveler preferred an overland journey instead of a trip by coasting vessel, he would have to put up with the inconvenience of a wearisome ride in a big, lumbering, springless stage over rough roads, his only solace the occasional pauses for rest and refreshment at old-fashioned change houses. In the Upper Provinces, he would have to contend with the wretched service of what were referred to at the time as the most poorly conducted railways in the world.

Two trains a day in each direction were sufficient to accommodate the traffic between the two largest Canadian cities. One made the journey by day, the other by night, and the run was scheduled for something like fourteen hours. The locomotives burned wood and there were frequent stops en route to re-load the tenders. Cars were small and light, the track poorly laid and the bumping and jolting terrific. One wretched tourist who endeavored to beguile the tedium of the journey by a game of draughts found to his disgust that it was quite impossible to keep the men on the board.

Postal System

The postal system in Canada fifty years ago differed very little from the present system except that very much higher rates of postage had to be paid, and it took much longer for letters to reach their destination. The rate to points in Canada, that is, Ontario and Quebec, was five cents; to the United States, 10 cents, and to England, 12½ cents. A special weekly service to Halifax, via Portland, having been arranged, a business man in Toronto or Montreal could send a communication to Nova Scotia for the sum of 12½ cents. As for British Columbia, it cost 25 cents to forward a letter to the Pacific Coast.

Statistics for the year 1863 show that there were in the Upper Provinces, 1,974 post offices in that year and that the number of letters carried was 11,000,000.

New Brunswick had 375 post offices, in which 833,625 letters were handled, and Nova Scotia 493 post offices, with 1,467,726 letters. The year's revenue for the three provinces was \$853,778, and the expenditure, \$896,303. As an indication of the extent to which the postal service has since expanded, it may be said that in 1915, the revenue for all Canada was over thirteen million dollars and the expenditure nearly sixteen millions.

Telephones

While the telephone was unknown in 1867, the telegraph and the Atlantic cable were both in existence, and so far as telegraphic communication was concerned, Canada was well served. Indeed, in Nova Scotia the boast was made that they had more lines of telegraph per inhabitant than in any other country in the world and, what is even better, lower rates. In Ontario and Quebec, the Montreal Telegraph Company, with over 3,000 miles of wire, controlled the situation, while in the Maritime Provinces the lines, about 2,000 miles in extent, were controlled by the American Telegraph Co. As there are to-day over 200,000 miles of wire in the telegraph systems of the country, it is obvious that here again there has been vast development.

The story of the telephone is all contained within the limits of the Confederation era. There were no telephones when Confederation was born. To-day there are between six and seven hundred thousand instruments in use, with over a million and a half miles of wire connecting them.

Electrical Street Railways

Electric street railways have been another modern development. In fact, in the year of Confederation, horse cars had only just come into use. Toronto's system had been opened in 1861. It consisted of six miles of track on Queen and Yonge streets, with eleven cars and 70 horses, a total investment of only \$175,000. Montreal had also about six miles of track with similarly small equipment. Halifax was a third city with a system of horse cars at that time. The innovation was not welcomed. One critic complained that "the street railway is an institution for the benefit of those who ride, at the expense of those who drive, and is a flagrant violation of the rights of the majority. The horse railway is a permanent obstruction; it practically divides a wide street into two narrow ones and a narrow one into two lanes. It is questionable whether it will be found profitable in Canada."

In the light of this hostile attitude, it is interesting to note that the tiny systems in the three leading cities of 1867 have since developed into a vastly important series of electric lines, located in practically every city in Canada, operating upwards of 1,700 miles of track and carrying annually six hundred million passengers. The capital invested in them amounts to over \$150,000,000.

Trade and Finance

Trade and finance have shown marvelous expansion in the fifty years of Con-

federation. When it is considered that in 1868 the country's total trade only amounted to a little over \$131,000,000, of which \$57,500,000 represented exports; that the export of manufactured products in that year scarcely amounted to \$2,000,000 and agricultural products exported were under \$13,000,000 in value, then the growth becomes all the more remarkable, for, in 1916, Canada's trade amounted to nearly a billion and a half dollars; her exports of manufactured products to \$242,000,000, and her exports of agricultural products to \$250,000,000. Her mineral exports in the same period jumped from \$1,800,000 to nearly \$67,000,000, and the products of her fisheries from \$3,500,000 to over \$22,000,000.

The development of trade has been graphically reflected in the expansion of the financial institutions of the country, notably the chartered banks and the insurance companies. There were as a matter of fact, more banks doing business in 1867 than there are to-day, but the banks of the Confederation year were very much smaller and, in several cases, they were in a notoriously shaky condition. In all, there were twenty-six of them in existence, with a paid-up capital among them of approximately thirty millions, or about a quarter of the paid-up capital of the twenty-one institutions now operating under Dominion charters. There were about 120 branches doing business, the large majority of which were located in the Upper Provinces.

Since 1867, sixteen of the twenty-six chartered banks on the list in that year have disappeared, either through failure or amalgamation, leaving but ten of their number to carry on the traditions of the pre-Confederation days. The survivors, in point of age, are the Bank of Montreal, Bank of Nova Scotia, Bank of British North America, Bank of Toronto, Molson's Bank, Bank Nationale, Merchants Bank, Banque Provinciale, Union Bank, and Canadian Bank of Commerce. Eleven new banks have been established, bringing the present total up to twenty-one.

To-day Canadian banks have over 3000 branches in Canada alone, not to mention agencies in the United States, the West Indies, and elsewhere. Their assets have grown since 1867 from seventy-five millions to well over two billions; their liabilities from forty millions to over eighteen hundred millions. They have deposits of over fifteen hundred millions as compared with twenty-five millions fifty years ago, and their circulation has expanded in the half-century from nine millions to over \$132,000,000.

Insurance

Life insurance was the smallest of Canada's financial institutions in 1867. Only one Canadian company—the Canada Life, which had been organized in 1847—was operating, and the total insurance in force of all companies, including British and American, did not exceed \$30,000,000. Progress in this one business alone has been little short of phenomenal. Company after company has been organized until to-day no fewer than twenty-six domestic companies are

reporting annually to the Dominion Department of Insurance, not to speak of fifteen British and sixteen American companies.

By the end of 1916, the insurance in force on the lives of Canadians amounted to nearly a billion and a half dollars, of which nine hundred millions was carried by our own Canadian institutions. The latter, whose assets in the year of Confederation were a mere bagatelle, now show accumulated wealth approximating three hundred million dollars; their annual income runs to over sixty million dollars; while they disbursed last year to policyholders or to their beneficiaries nearly twenty-five million dollars in cash.

The business of fire insurance has enjoyed a similar expansion. Our Canadian companies, then few in number and unimportant, had at risk in 1867 about fifty million dollars, on which they were receiving premiums of somewhat less than

ever, enough has been written to give a faint idea of the Canada of fifty years ago and with this in mind it is not difficult to picture mentally the extent of development.

COAL SITUATION IMPROVING

C. A. McGRATH, controller of Canadian Fuel Supply, has returned to Ottawa from Washington, where he has been consulting with the American fuel controller, Mr. Peabody. Mr. McGrath says that the American authorities are dealing with the fuel situation in the thorough manner in which the difficult problem requires. They have opened a bureau and obtained the services of mining and transportation authorities. Mr. McGrath states that at Washington he found a friendly feeling for Canada and a disposition to deal fairly with the Dominion in the matter of fuel with which he is concerned. Mr. McGrath

SHIPBUILDING IN CANADA

By A. W. Robinson*

THE question of shipbuilding is an urgent one at the present moment. Steel vessels cannot be built promptly because the steel mills are sold out for ship plates nearly two years ahead and because skilled labor and shipyard equipment are also short and cannot be created quickly. We are therefore reviving the art of wooden shipbuilding and meeting with some success, especially on the Pacific Coast.

There are difficulties also in building wooden ships, among which are: First, skilled labor accustomed to the regular practice is scarce and not equal to the tonnage required; second, our sawmills turn out straight lumber, whereas the construction of ships, especially in their frames, requires many curved and irregular-shaped pieces, which it has been the ancient art of wooden shipbuilding to produce; third, the lumber available is unseasoned and will shrink and not make a good job when done. It seems to me, therefore, that the question should be taken up anew in the light of present conditions and requirements, and that we should not attempt to build a wooden ship on exactly the old lines or in the old manner.

Composite Construction Suggested

In making studies on the question, I have come to the conclusion that a composite construction would meet the case better than steel alone or wood alone. We can obtain steel angles and channels for the frames and also straight lumber in ordinary merchantable sizes. We can also get a certain number of handy woodmen and laborers who, though they cannot be classed as ship carpenters, could do plain work of this kind under instruction.

My suggestion is, therefore, that the vessels be built with steel frames, made of plain merchant sections, with a minimum of curved work, and that the remainder of the vessel, consisting of the beams, keelsons, deck planking and side planking, be made of wood in plain straight pieces as far as possible.

A vessel built in this way would, in my opinion, be more economical, both in first cost and in operation than an all-wooden ship, for several reasons, as follows:—

- 1—Very few curved wooden frames are required.
- 2—The work could be done largely by ordinary labor, under proper supervision.
- 3—The ship would be stronger than an all-wood ship.
- 4—It would have a greater cargo-carrying capacity as compared with the all-wood ship, on account of the reduced size and space required for the frames.
- 5—The fastenings of the woodwork to steel frames by means of screw bolts would be more secure than the old-fashioned drift bolts and spikes used with wooden frames, and could be tightened up as the wood shrinks.
- 6—The ship could be built more promptly and be a better job when done.

*The author is a well-known naval architect in Montreal.



WOOD SHIP CONSTRUCTION IN BRITISH COLUMBIA.

half a million dollars and paying losses of from a quarter to half a million dollars a year. Last year, the domestic fire companies had \$663,758,129 at risk, on which they were receiving premiums of nearly five million dollars, while they met losses during the year of over half that amount.

One might proceed and produce figures bewildering in their detail to demonstrate how far Canada has progressed in every department of business activity since 1867. The tremendous expansion of agriculture due to the opening up and settlement of the West; the development of mining, which is placing Canada in the forefront of the mineral-producing countries of the world; the growth of the fisheries; the extension of hydro-electric power in industry; these and a hundred other matters might easily be referred to as affording means of gauging the country's fifty years of progress. How-

does not think that Canada will have any great difficulty in obtaining the quantity of anthracite required, if the transportation companies are able to distribute it promptly to the points in the Dominion where it is required.

The supplying of bituminous coal presents a more difficult problem. Mr. McGrath says that he requires immediately a precise statement of bituminous requirements of Canada for the coming winter. He desires every Canadian consumer of bituminous coal immediately to write him at Ottawa, stating the quantity of coal he had been consuming and the quantity he will require during this summer and the coming winter. Total quantities and the monthly requirements should be stated. Any consumer who wants to ensure his supply is advised to state his requirements without delay and state them accurately and honestly.

Evolution and Revolution in Machine Shop Practice

By J. H. Rodgers •

Conjointly with the production of munitions came the demand for machine tools, creating a situation that required the utmost resources of the country and the greatest ability and initiative of our whole engineering profession, individual and collective. The results of such a circumstance have been reflected in attainment of hitherto undreamt-of achievement.

THE remarkable growth of metal-working industries during the past three years has undoubtedly been the outstanding feature of an otherwise abnormal period of activity, not alone in Canada, but in every other country in the world. While it is true that the primary cause of the development gives cause for regret, it has nevertheless been the means of opening the eyes and clearing the vision of communities and nations who had too long been oblivious to the gathering clouds that threatened the future peace and welfare of the entire universe; morally, socially and commercially.

During the early months of 1914 Canada had experienced a period of severe depression which became somewhat aggravated immediately before, and for a time after, the opening of hostilities. The almost universal belief that war between two great civilized countries like Eng-

land and Germany was practically impossible kept the vast majority of people in an optimistic state of mind, and we, too, it may be said, were struck with amazement when the event actually happened. The depression that had been so pronounced a few weeks before became almost a panic when the sudden entrance of Britain into the maelstrom of Europe was definitely announced, and the predominating feature throughout the entire country appeared to be the complete disorganization of every line of activity. Fortunately, however, the "stage fright" was of short duration, as we then began to realize more clearly the magnitude of the possibilities that the early future might have in store for us. The first to awake were the masses of our citizens themselves, this being reflected in the anxiety for news of European developments, hope being still strong that actual hostilities might somehow in the end be prevented. This craving for information

resulted in greatly increased activities in certain directions; telephone companies, newspaper offices and other sources of news distribution having to increase their staffs and work overtime to satisfy the urgent demands made upon them. Street railways did a flourishing business, taking people to and from the newspaper offices, where the bulletins were hourly displayed.

When, early in September, the country began to settle and prepare to assist in carrying the burden of the Empire obligations, the general impression seemed to be that Canada's principal duty would be to supply men for overseas service, and the response in this connection during the first six months of the war will ever remain a bright historical fact in the pages of the world's history. It is however along the lines of industrial activity, and more particularly in connection with what the metal-working branches have accomplished towards the

•Associate Editor, Montreal.

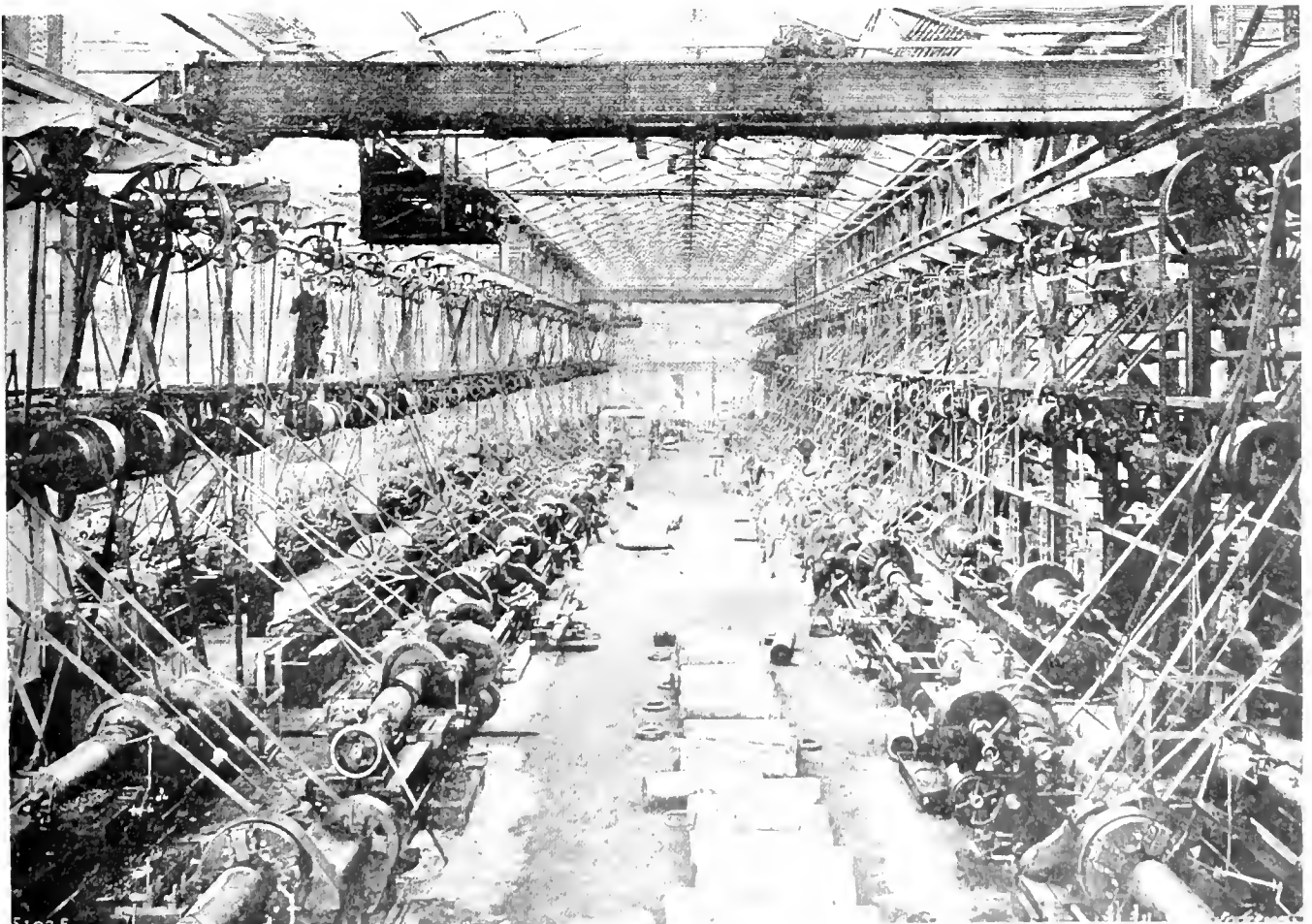

SPECIALLY BUILT AND EQUIPPED SHOP FOR MACHINING LARGE SIZE HIGH EXPLOSIVE SHELL.

successful prosecution of the war, and the achievement of our many machine shops in the manufacture of the various classes of munitions during the past three years, that this article has to deal

equipment resulted in much confusion in the progressive movement of the product through the shop; but where it was possible to previously arrange the position of the various tools, this objectionable

but that in a large measure she was able to set the pace for greater and more efficient production. The outcome of this was the renewal of orders for shrapnel and 18-pdr. high explosive shell, and the placing of substantial orders for the larger sizes. This eventuality was probably the first intimation of the magnitude of the task that the Canadian people were called upon to perform, and from that time it might be said that a new epoch had been started in the industrial development of our country. The placing of shell orders was so general and widespread that it was practically impossible to secure equipment of a suitable character for the desired purpose, and the boom that followed in the machine tool industry has never been equalled in this or any other country. Had sufficient machinery been available to meet the enormous demands of the abnormal conditions, the probability is that the methods of manufacturing shells would have still been along the lines that were the general practice during the early days of the war.

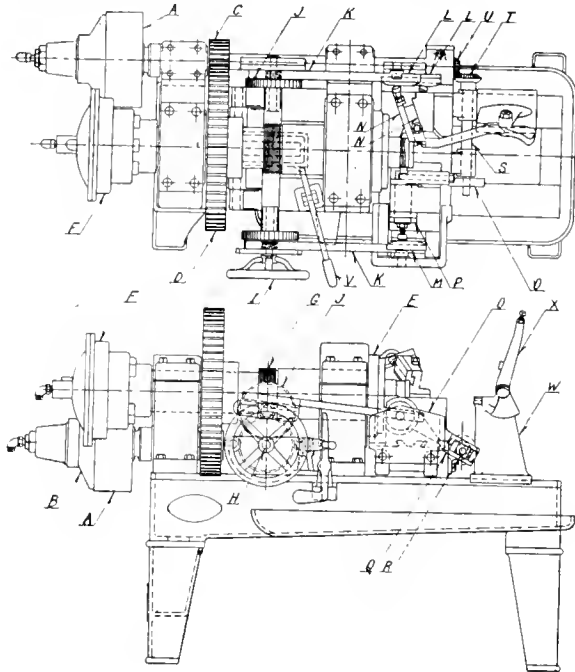

INTERESTING SHELL COPPER BAND WAVE AND GROOVE MACHINE DEVELOPMENT.

Initiation of Munitions Manufacture

It was towards the close of 1914 that rumors began to circulate that the manufacture of shells in Canada was being given careful consideration, but for some time many were dubious of undertaking such a task, accomplishment of which required knowledge and experience of such a nature that few in this country were possessed of. The lack indicated failed to dampen the enthusiasm of those of our captains of industry, who had set themselves to carry out the establishment of shell-making in this country, for, after a few preliminary negotiations, the decision to manufacture was immediately followed by actual operations. It must not be supposed, however, that the foundation of the present industry was laid with the intention of erecting the massive structure that has subsequently been raised. Optimism had not yet entirely disappeared, it being still the belief of a majority that the war would be of short duration, and the need of large quantities of ammunition would be unnecessary. Therefore, when those plants that had first undertaken the production of shrapnel shell were equipping for this purpose, they did so with the belief that the first order would probably be the last, and little provision was made for future extensions or increased production. The failure to foresee the future was one of the chief factors of the early difficulties that beset many manufacturers who were previously provided with much of the equipment suitable for making shell. Regarding manufacturing methods for successful shell production (that of performing separate operations on different machines), the early utilization of existing

feature was largely eliminated. Some difficulty was experienced during the initial stages of the shell industry in obtaining the desired machinery, it being the prevailing opinion that standard equipment of high quality was the only kind that could be used for the purpose.

Renewal and Still Larger Orders

As time passed, the growing need for more and larger shells was impressed

Plant Extensions and Developments

The realization of the urgency of the Empire's needs stimulated to action many wavering plant executives, their response being exemplified in the mushroom growth of numerous new factories and additions to existing ones. A feature of early conditions, and one that reflected unfavorably upon the chief munition authorities, is the unquestionable fact that shell manufacturers were compelled to a large extent to grope about for specific information regarding officially recognized manufacturing methods, both as regards the making of shell and their parts. In the end they had to rely upon their own initiative for the design and subsequent adoption of such devices and attachments as would facilitate production. This feature, which at the time

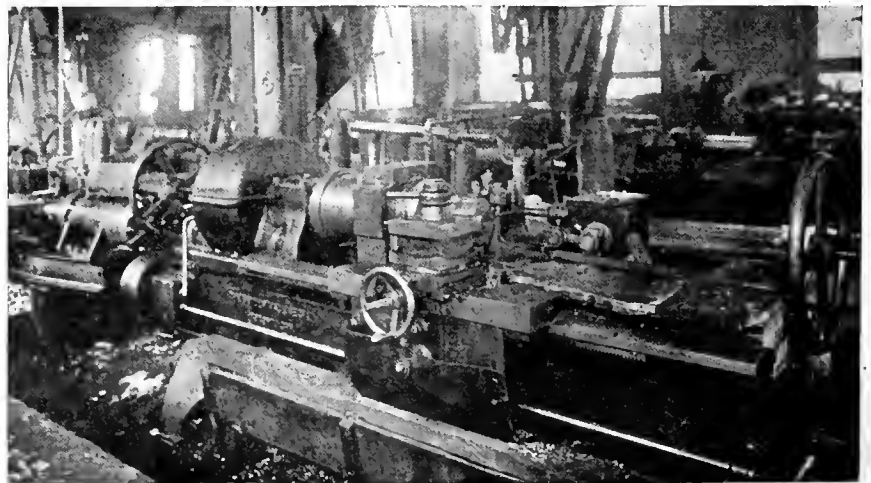

SHELL WAVING AND GROOVING FOR COPPER BANDS ON SINGLE PURPOSE LATHE WITH SPECIAL ATTACHMENT.

upon the minds of those who had inaugurated this new business line into the Dominion, and the success of the initial attempt had proven to the Shell Committee the fact that Canada was not only equal to the manufacture of munitions,

may have appeared one of the chief difficulties of the situation, has undoubtedly proven to be the essential factor in the remarkable evolution of the special purpose machine. Too much credit cannot therefore be given Canadian manufac-

turers for the voluntary mobilization of their industrial resources, both physically and mentally.

Growth of the Special Purpose Machine

When the many firms that had contemplated the production of shell were confronted with the problem of securing equipment, and the fact that the supply was far below the demand, a temporary feeling that the task was beyond them seemed to take hold of the various executives. This depression was however, short lived, and from a condition that was next to despondency arose the spirit of determination that has been characteristic of the people of Canada during nigh three years. To meet the requirements of the situation therefore, it was necessary for each individual plant to "work out its own salvation," with the result that the revolution in machine tool design, for the accomplishment of a specific purpose received a stimulus from which great things have been accomplished. Machines that had been relegated to the scrap pile, and others that had not even received a passing thought in connection with their being used for shell operations were given careful consideration with a view to their being utilized for some work in the routine of machining. As a result, not only were many of these discarded tools of good service, but not a few of them proved to be the nucleus from which the special or single purpose machine has been constructed.

The development of special attachments for the more rapid performance

it possible to manufacture munitions on a scale that would have been considered beyond all possibility at the commencement of the war. While there are at present large numbers of standard lathes

reveal the fact that attachments have been added and others removed to provide increased productive powers to each and every machine. When occasion required the replacement of a certain tool

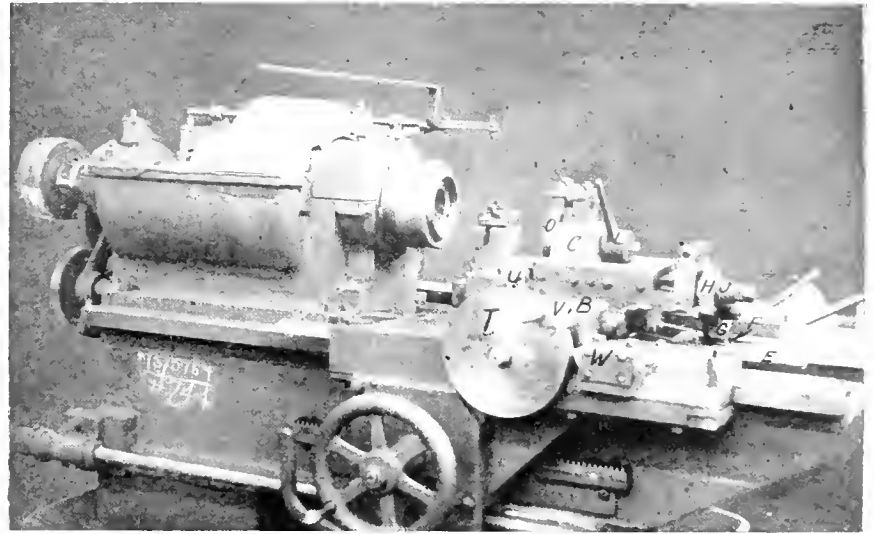

SPECIAL TURNING AND THREADING EQUIPMENT FOR 8-INCH H.E. SHELL ADAPTERS.

doing very good work in various plants throughout the country, it might be well said, and with no great stretch of imagination, that if the thing had to be done all over again, the recognized standard lathe so familiar to us all, would receive little attention in the actual machining operations of any size of

it was seldom that another of the same type was installed, owing to the rapid development that has taken place both in design and efficiency.

New Order of Things—Typical Example

While visiting a plant some few weeks ago that has been making shrapnel from the very beginning of the war, there was forcibly impressed upon the writer, the changes that have taken place in this particular shop during the past two years. With practically no addition to their floor space, this firm who two years ago were working to full capacity, turning out 700 or 800 shells per day, are now producing on an average about 5000 per day; with probably one or two exceptions every machine at present in operation is of special design and constructed on the premises. While the main portions of many of these machines are practically identical, the machining attachments are designed for a specific purpose, and the machine could not very well perform another operation than that for which it has been constructed. Under existing conditions, however, this feature has no drawbacks, as each machine can be kept constantly at its own task during the entire 24 hours of the day.

Tool Making Factor

During the past three years, with the probable exception of the first few months of disorganization, everything seems to have worked out to meet the requirements of the changing conditions. Before it was definitely learned that shells were to be made in Canada, and even afterwards, many skilled workers had joined the colors and manufacturers were wondering what could be accomplished if a scarcity of mechanics should develop and they were forced to rely upon unskilled help for the production of a product that

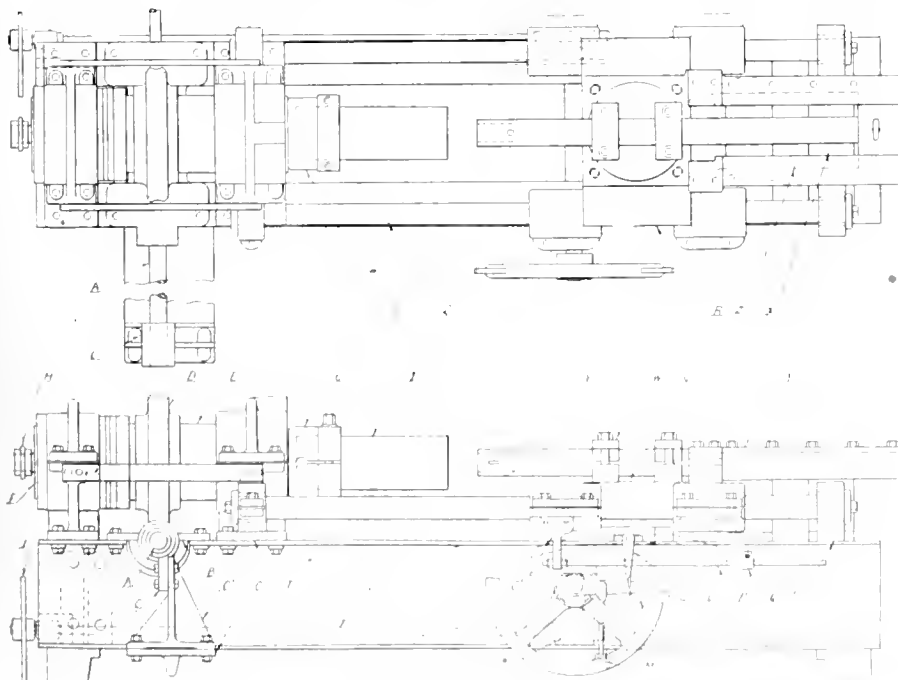

DIAGRAMMATIC REPRESENTATION OF 6-INCH SHELL BORING MACHINE.

of certain operations has also been the ground work for the design and construction of special equipment for the making of shell. From these impromptu devices have been evolved many of the single purpose machines that has made

shell. As one passes through the shell plants of to-day, it is difficult to realize the changes that have taken place since the inception of this vast industry. Where the equipment appears to be the same, close observation and inquiry will

required such accuracy in its manufacture. Under ordinary conditions, these fears might have been realized, but as events transpired, the danger did not lie so much in the lack of skilled mechanics for the machining operations on shells. Where the difficulty did arise was in the inability to obtain sufficient toolmakers to provide the necessary jigs and gauges for the maintenance of maximum production. Although previous to the inception of shell-making there was a large surplus of unemployed, it eventually proved a difficult matter to secure the men required for the capacity operation of the various plants, and it was found necessary to engage any class of help, no matter what their previous experience.

these latter being too monotonous for effective accomplishment.

Effect of High Wages

One of the factors that threatened to disrupt the operation of many plants was the scale of wages incidental to the production of munitions for which exorbitant prices were being paid; not that these were excessive under the circumstances, but so in comparison with what had been recognized as reasonable wages before the war. Here were men drafted from all departments of labor without any previous experience in machine shop practice, who after a few days of preliminary training were receiving three, four and even five times what they had ever earned before, while the mechanics and tool-makers about the shop who told these men what to do and who set the machines in order that they could serve, were forced to work at less than half the wage. Many mechanics, in con-

out of the meantime activities of the industrial world and the altered conditions that will prevail when peace is declared. Had the war been of short duration, it is reasonably fair to assert that we would have again returned to the old condition where the great majority of the people of the so-called civilized world were undoubtedly (and probably unconsciously) relying on Germany for certain classes of brains and material. The experience now so forcibly pressed upon us will not, however, permit of us again placing ourselves at the industrial, commercial or intellectual mercy of such a country as Germany, or in fact any other.

The revolutionary manufacturing methods of the war years that have just passed will make it almost impossible for things to follow along the same course as that preceding the war. Industrial developments, both scientific and practical, have been of such a character that future commercial activities will be conducted with a wider and more expert knowledge than ever in the past. The rapid and efficient progress in the manufacture of steel and the extensive experiments that have been carried out will place this industry in a much superior position, and will form a basis for still further developments in this and kindred industries.

Machine Shop Practice on New Basis

Out of the manufacture of shells will evolve a new practice in connection with machine shop development. The methods that have proved so successful in the production of munitions on such a vast scale will naturally have considerable bearing upon the future practice of plants manufacturing in large quantities. The standard type of machine will not likely be superseded by any other, but where it is possible to manufacture articles of a special nature, using the principle of the single purpose machine for separate operations, production methods will undoubtedly undergo many changes. It is generally supposed that many of the machines now engaged in the making of shells will be fit for nothing but scrap after they have served their purpose; still there will also be a great number of those special machines that will find a useful place in the work of many plants.

Copper and Brass Products

Not only has the shell activity enlarged our steel outlook for the future, but the component parts, such as copper bands and cartridge cases, have developed an industry that will undoubtedly mean much to Canada when the post-war readjustments are being made. The copper and brass requirements for the manufacture of cartridge cases and the parts in connection with the various shells have grown to such proportions that the production of these has become equally important with that of the shell bodies. Plants now established in the Dominion for the manufacture of copper products, while primarily operated in the interests of munitions, will likely take a leading position in domestic activities after the war. In many respects, the tools now engaged in the production of shell may be of little use for any other purpose, but

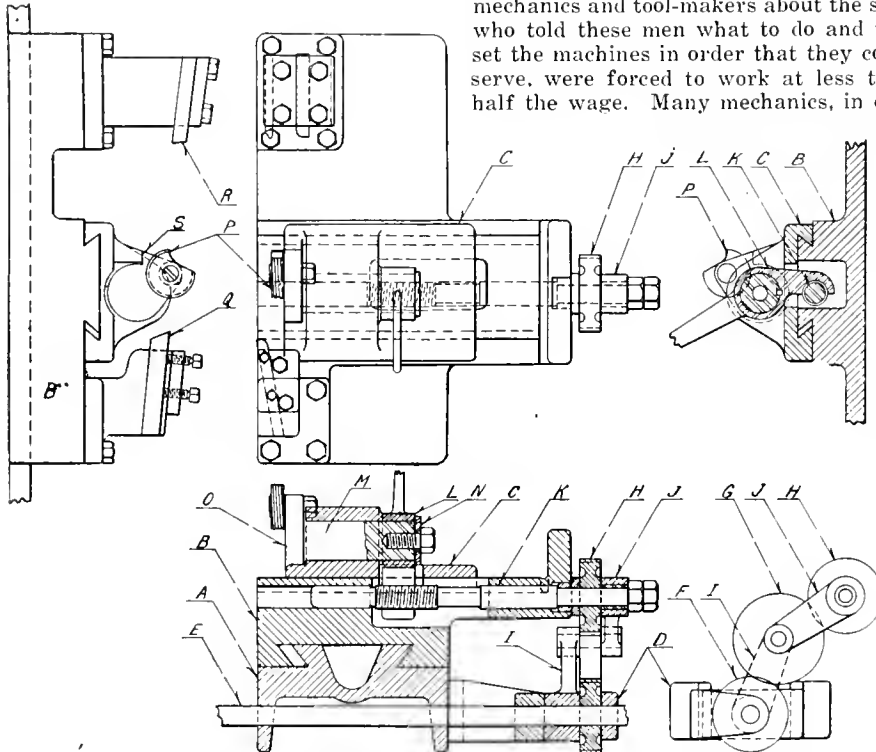

SPECIAL TURNING AND THREADING EQUIPMENT FOR 8-INCH H.E. SHELL ADAPTERS.

This at first had many drawbacks, owing to the fact that many of the men engaged had never seen the inside of a machine shop before, and these had to be taught some of the fundamentals before any progress could be made. This was particularly true where such men were placed on standard lathes or other tools that had many attachments of which they knew nothing, and which were not required for the special work they were engaged in. With the introduction of the special machines, however, the possibility of getting mixed in the operation of the mechanism was largely eliminated, and from that time it mattered little whether a new man was a mechanic, baker, barber or bootblack, as he soon became skilled in the performance of his particular duties. As a matter of fact, it was often found that men of this description could be relied upon to do more effective work than mechanics who had been accustomed to perform their work in the variety form; the repetition style of single operation to

sequence, forsook their relatively easy positions in the tool room to seek work on shell machinery where the remuneration was considerably greater. To retain the services of their tool-makers, many firms found it necessary to substantially increase the pay of mechanics in their employ, thus adding to the expense of operation, which during the first year of the war was none too light, owing to the many difficulties relative to specification requirements, and experiments incidental to the establishment of an entirely new industry.

After the War—What?

The question has often been asked as to what conditions will be after the war? It is very doubtful if anyone could, with any degree of accuracy, give a true answer to this question, but from the developments and experiences of the past three years it is probably safe to draw a few conclusions in the nature of a prediction as to some of the changes that may arise

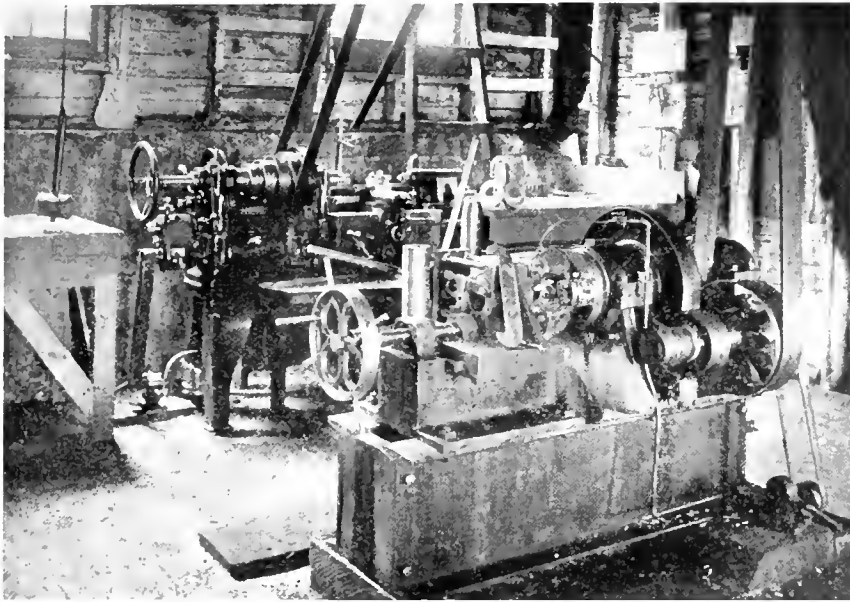

ROUGH NOSING AND PROFILING H. E. SHELL.

the machinery now used for the manufacture of brass discs and also cases will be in comparatively good condition and fit for a wide range of commercial work. The essential feature, however, will be to find sufficient work of a suitable nature to keep the large number of presses now used on cartridge cases engaged in normal times.

The time is not yet opportune to predict the actual use to which the bulk of this equipment will be put, but with what has been learned during the past few years regarding more efficient forging and drawing of copper, brass, and steel material, it may be expected that many revolutionary methods will take place in the manufacture of small parts that have formerly been made in other ways. This seems to open opportunities for the replacing of many small cast parts by similar pieces manufactured from sheet stock and pressed into the desired shape,

giving greater strength with lighter material.

Post-War Status of the Mechanic

The status of the mechanic will be one of the most serious problems after shell-making activities have been concluded. With a short war and a similar acquaintance with the operation of mechanical equipment, the possibilities of a ready return to their previous calling was more than likely, but large numbers of men and boys have virtually served an "apprenticeship," or a period of time equaling that served by the average mechanic of to-day, and it is more than probable, in fact, a certainty, that large numbers of these shell "mechanics" will desire to continue in this line of work. If certain manufacturing methods are adjusted to suit the revolutionary changes that have taken place, the situation may be relieved of much of the pressure that

would otherwise be evident. Men, who before the war, were content to work for comparatively small wages, may not be satisfied to again do so if they think they can hold a position in a machine shop where the remuneration will be almost double what they would receive at their old work. Many of these men, three years ago, did not know the difference between an eighth of an inch and a thirty-second, and many of those who did were not required to work closer than the former measurement. Their knowledge of these matters has undergone radical change, and in place of sawing a board to a line that is one-eighth of an inch wide, or cutting hair for appearance, these men are actually working to a thousandth of an inch, and have also become very apt in the manipulation of the various tools and gauges. The fact that female labor has been largely and successfully requisitioned for shell making consti-

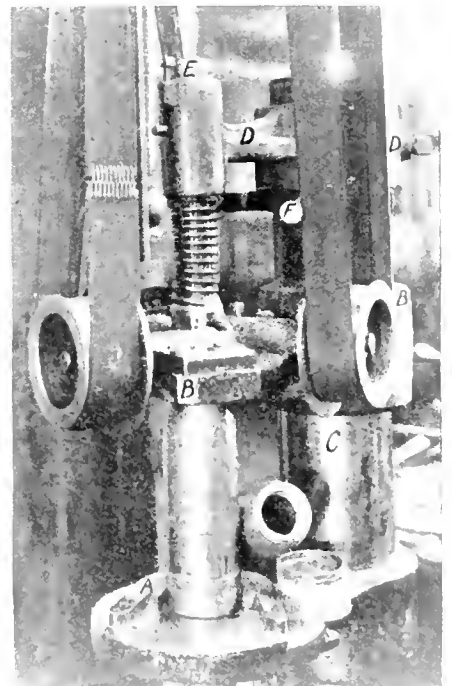

NICKING SHELL NOSES

tutes an addition to the problem of the mechanics post-war status.

Shipbuilding

From the earliest days of the war, the question of ocean tonnage has been an ever-present and pressing problem, developing in acuteness since the submarine became a contending factor in the destruction of life and property. It is unnecessary to emphasize the importance of this particular phase of modern warfare and its possible effect upon the commerce and general well-being of all nations, it being enough to say that the wastage must be replaced as rapidly as possible in order to prevent serious consequences in the matter of the food supply of various countries. How this objective is to be achieved is the question of the hour, and one also that will continue

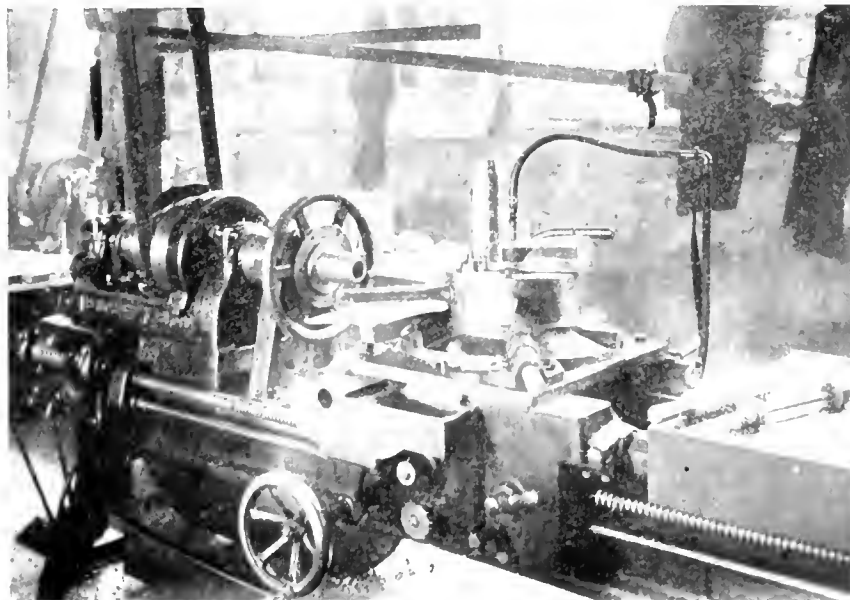

INSIDE SHELL FINISHING EQUIPMENT.

with us even after the war has terminated; in fact it may be more pronounced at that time than it is at present. As a companion activity to that of the manufacture of shell, and one that will become an essential industry for many years after the war, it would be well for Canadian manufacturers to give this matter equal consideration with that of munitions with a view of placing it on the same successful basis as that at present maintained by the latter industry. While the nature of this new obligation may not permit of the same tactics in establishing a Dominion-wide industry, it might be well to consider the possibility of nationalizing the undertaking so that the entire operations may be controlled and developed along the lines of the past three years of munitions manufacture. The difficulties that surround the actual construction of the hull and its component parts make it evident that this can only be successfully accomplished close to a permanent waterway, and by a properly constituted shipbuilding plant. In the case of internal equipment of almost every description, however, there seems to be no good reason why production could not be undertaken somewhat on the lines of shell manufacture. With the cessation of hostilities, thousands of machine tools will be idle all over the country, and with a little forethought it might be possible to utilize a large portion of these in furthering the speedy progress of vessel equipment, so that the shipyards could concentrate all their efforts on the fabrication of the main structure.

Opportunities and Responsibilities

Apart from the ravages of war, there appears to have opened up for this country possibilities that could never have taken place under any other conditions; closer co-operation between master and man, and also between the captains of industry and their various executives; intercourse between the numerous industrial plants in all parts of the country; all classes of workmen, draughtsman, tool-makers, machinists and even unskilled workers, have had to do and think things which otherwise would never have happened. The vast acquisition of additional knowledge concerning the foundry, machine, and chemical sciences, has opened the way for very material advancement, and the time appears to be ripe for Canada to pluck some of the fruits of the past three years; fruits that have matured through the perseverance of men who have sacrificed much for the greatness of Canada's future. All that is needed is capable pilots to guide the course of the new industrial ship of progress, avoiding the narrow channels of industrial strife and the sunken rocks of political prejudice.

Lest we forget, however, it might be well to call attention to the fact that eventually Canada must again receive to herself the human remnants of a devastating war, men that will return physically unfit for the duties they were accustomed to perform before the war. What the country owes to these men, God only knows, but it would be a sad day for this country, and more especially

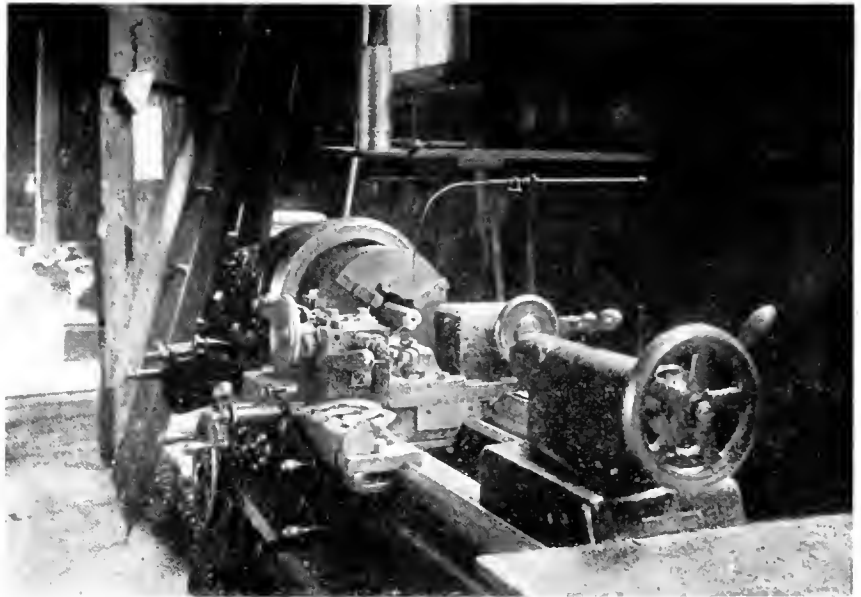

SHELL COPPER BAND RECESSING EQUIPMENT.

those interests that have reaped financial prosperity through the personal sacrifice of these very men, if some means were not provided for their permanent welfare on their return home. Steps should be taken by the various industrial heads in co-operation with the Government to establish some form of national manufacturing industry that would provide employment of a suitable character to men unable to compete in an open market. We, as a nation, are in duty bound, to provide for these men who have made it possible for our progress of the past; and our future cannot be darkened by the possibility that any of these men will regret the part they have taken in shielding this land of ours from the ravages of the murderous Hun.

It is unnatural to expect that individually controlled plants, in competition with others, will give this question the consid-

eration it deserves; not that each would be unwilling to share the burden, but as the effects of the war become less pronounced, there arises the possibility that their recognized responsibilities may not seem so great as formerly, with the result that the country would be over-run with maimed men discharged because they were unfit to perform the duties required. Under a system controlled by the government, and aided by the manufacturers in common, this contingency could be avoided, as where a man was found unfit for certain employment, other work of a suitable character could be found and, if not, it would be the duty of the Government to provide for him the same as for any other; the essential factor being that he be amply provided for. Let it be demonstrated that the industrial aspirations of the post-war period are not to be attained without first considering those to whom so much is due.

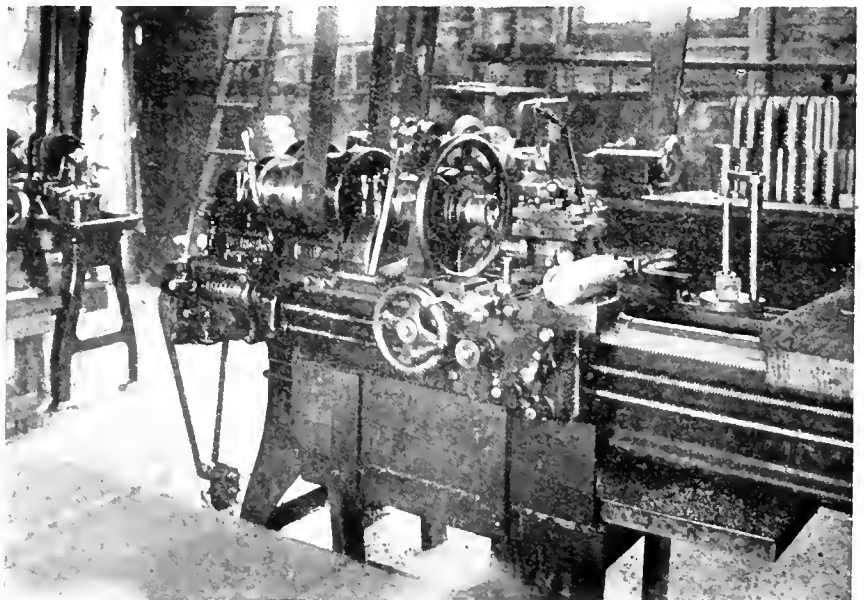

SHELL BASE RECESSING EQUIPMENT.

Canada's Machine Tool Industry in Retrospect

By the Editor

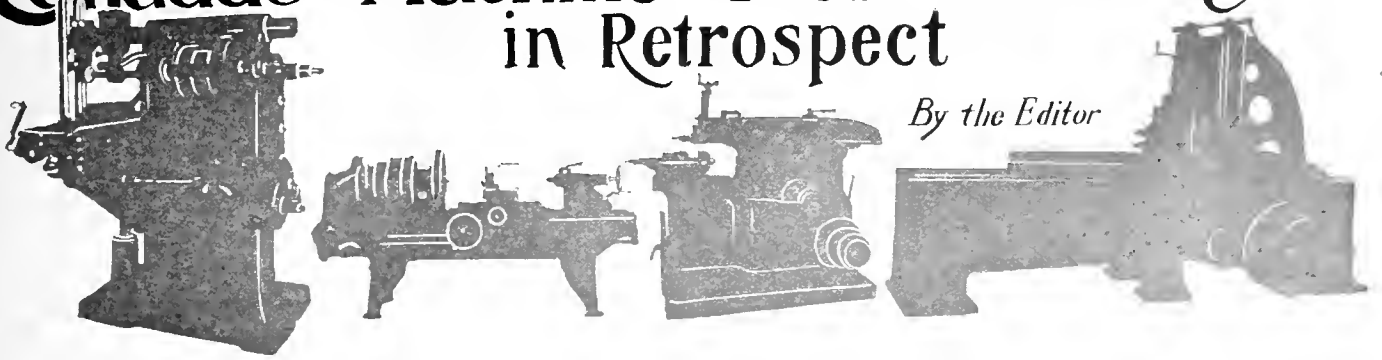

It will be readily gathered from the article text and illustrations that Canada's machine tool manufacturing achievement is no mean one, rather must it be reckoned as one of her prominent national assets. That its future development will be much more rapid than it has been in the past, goes without saying, for not only do we now have a substantial base of operations to branch out from, which the early pioneers had not, but we have through participating in munitions manufacture realized the possession of a competence in things mechanical that was either previously considered non-existent, or at best non-vital.

THE initiation of machine tool manufacture in Canada according to records available antedated Confederation by something like twenty three years. Strictly speaking, of course, the actual production of what later became known as machine tools did not then really commence, the establishment of business enterprise to that end was, however, successfully accomplished. It is worthy of note at this juncture that the chief centres of Canada's machine tool industry to-day, both wood and iron working, are still to be

the fact that the exigencies of the munitions situation during the past two years or more had the effect of adding materially to the number and territorial distribution of Canadian machine tool manufacturers in order to meet the very abnormal requirements of our shell forging, shell machining, and shell loading plants. More of this latter phase of the situation anon.

As might be expected, away back around the year 1844, settlers—for the the most part, if not wholly from the Old Country, directed their efforts, whether for an existence or a competence, to agricultural and lumbering pursuits; the latter being at one and the same time a necessity so as to provide the construction materials for a shelter and a home, and for the clearing of the land for purposes of cultivation. It is somewhat significant that the men who had braved the perils of the Atlantic, and had endured the discomforts of the then long voyage across its angry bosom on none-too-well-found ocean transports, were not in every case "sons of the soil" in their native land. Some of course could lay claim to such a title, others had been engaged in pursuits somewhat akin, while others again, were tradesmen—mechanics if you will, because more correct—nimble with hand tools, keen of perception, and brimful of ideas. Sterling integrity was, however, a marked feature in all, which taken together with nature-endowed aptitude for surmounting difficulties, enables it to be truly said of the result of their activities that "their works do follow them."

Galt, Ontario, so far as we can gather, has rightful claim to be given attention first in matters concerning the inauguration of machine tool building in Canada, for there we find that James Crombie established a foundry in the year 1844, twenty-three years previous to Confederation. In 1847, Dean Fisher

and Morris C. Lutz began a partnership in Galt as manufacturers of agricultural machinery and, as indicative of the like desire as now exists all over Canada to foster the establishment and location of industries, we find one James Dickson, owner of the township lands, leasing same at reasonable rentals, bonusing manufacturers, leasing water-powers for ever at a nominal annual rental, and building the dams accessory to the latter, etc.

Goldie & McCulloch Co., Galt, Ont.

In the year 1849, John Goldie and Hugh McCulloch, both a number of years deceased, entered into partnership and purchased from the already-mentioned

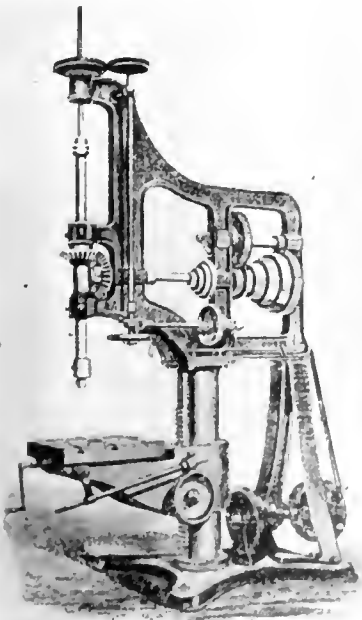

VERTICAL DRILL BUILT ABOUT THE YEAR 1869

found in the locations of its inception—Galt and Dundas, Ont., notwithstanding

This article was prepared for and is here reproduced from the Toronto "Mail and Empire" Special Confederation Number.

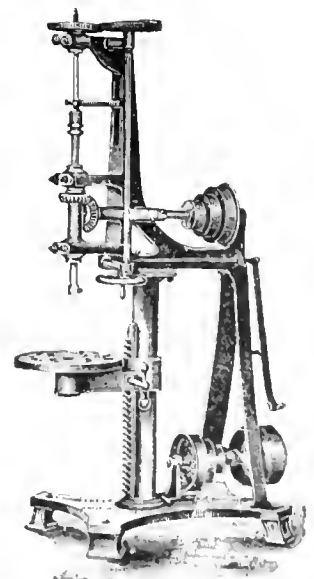

DRILL BUILT AT DUNDAS IN 1865.

James Crombie, his foundry established five years previously, and known as the Dumfries Foundry. These two Scots,

then in the prime of manhood had, in so doing a taste for the first time of the responsibilities attaching to the management and administration of a manufacturing business. Relative to the enterprise they demonstrated, it has been given us to understand that their working capital consisted chiefly of high purpose, pluck and energy, all of which qualities, as might be expected, have had their reward in the intervening years, and in the honored place which the Goldie & McCulloch Co. of Galt, Ontario, now fills in Canada's general mechanical and steam engineering activities. The plant taken over from James Crombie was quite small, the pay-roll, as a criterion, embracing only some twenty-two persons. To-day, the employees number over five hundred, which, taken in conjunction with the substantial nature and extent of what are known as the North and the South Works of the firm, gives abundant evidence of rapid yet steady growth through a period of sixty-eight years.

Originally the firm engaged in what was known then as a general foundry business, same including the manufacture of boilers, engines, and mill machinery. Woollen mill machinery and the manufacture of machine tools for wood-working services were added as opportunity offered and necessity demanded, with the result that in the latter feature something akin to pioneer effort had been successfully undertaken and a reputation established. In the course of time, around the year 1880, the Goldie & McCulloch Co., gradually withdrew from the manufacture of woodworking machine tools and general machinery, having decided to specialize in the production of fire and burglar proof safes and vaults, stationary steam boilers and engines, the latter more especially of the simple slide valve and Corliss type.

In more recent years, they have devoted attention to the manufacture of Wheelock, Goldie-Corliss, Ideal horizon-



THE LATE JAMES COWAN, A PIONEER IN WOODWORKING MACHINE TOOL BUILDING.

tal high speed, and vertical high speed engines, steam turbines, water-tube boilers, heaters, pumps, condensers, return tubular boilers, transmission and elevating machinery, safes, vaults, vault doors, etc. The North Works built about twelve years ago embraces a shop 480 ft. long by 120 ft. wide, constituting one of the largest of its kind in Canada. In these war times, not a little of the firm's activities comprise the forging and machining of shrapnel shell, as well as the building of marine engines.

Cowan & Co., of Galt, Ltd.

Getting back to the partnership of Fisher & Lutz, we find that the former retired in the early "fifties," his place as an active member of the firm being taken by Peter Cook, and the enterprise strengthened as a whole by the assumption of James Cowan as a silent partner; the undertaking was now known as Lutz, Cook & Co. Stoves, plows, and threshing machines were the particular lines manufactured. It is of interest to note here that the James Cowan above-mentioned was father and grandfather, as the case may be, to the men who to-day are the executive officers of the well-known firm of woodworking machine tool builders, Cowan & Co. of Galt, Ltd. In 1859, Peter Cook, partner, was accidentally killed while at work in the plant, his death causing the firm name to be changed to Lutz & Co. Thomas Cowan, son of James Cowan, entered the firm at this time in an active capacity. Reapers, mowers and agricultural machinery of a variety nature were next added to the already noted lines of manufacture.

In the early "seventies" Lutz & Co. sold out to Cameron & Co., the latter firm consisting of J. Cameron, J. Ballantine and J. Smith—woodworking machine tool mechanics from the plant of Goldie & McCulloch—and Thomas and James Cowan, of the defunct Lutz & Co. The silent partnership of James Cowan was maintained unbroken, we might say, all the way from his association with Lutz,

Cook & Co., until his death in 1897. The manufacture of engines, boilers and woodworking machinery occupied the attention of Cameron & Co to a large extent. Smith and Ballantine severed their connection with the company within a year or so, and at a later date when Cameron expressed a wish to retire, James Cowan bought his interest, the firm name becoming thereafter Cowan & Co. In 1902 incorporation as Cowan & Co., of Galt, Ltd., was procured. Since 1905, the manufacture of engines, boilers and miscellaneous machinery has been entirely discontinued, the whole effort and energy—administrative and operative—being concentrated on the production of high-grade woodworking machine tools of all types, and for special or general service requirements.

Of human interest is the fact that James Cowan was a shepherd in the lowlands of Scotland before coming to Canada in 1834. Further, his trip from his native to his adopted country constituted his honeymoon. That Galt has grown in the period under review may be gathered from the statement that, when Mr. Cowan and his bride claimed its hospitality, there were but fourteen houses within its borders. Mr. Cowan was member for South Waterloo in two parliaments—Upper and Lower Canada period, and was in the House when Confederation was put through. For a number of years he held the appointment of Federal Government arbitrator over the territory extending from Halifax, N.S., to Winnipeg, Man., his special duties being the adjustment and settlement of claims in which railroads, public works, lands, and individual interests were involved.

Arising out of Canada's munitions industry of the past two and a half years, and particularly in relation to the shell shipping box feature, a series of special boring machines were designed and built, the spindle capacities of which were capable of producing 1-2-4-5-12 and 18 screw holes at one operation. Other special shell box machinery designed was

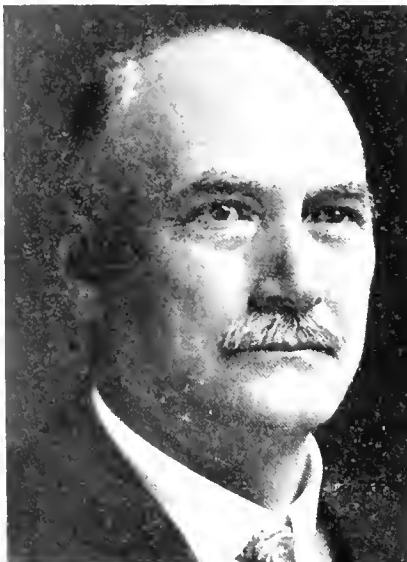

HENRY BERTRAM.
Son of John Bertram.



BRIG.-GEN. SIR ALEXANDER BERTRAM.
Son of John Bertram.

that relating to the rapid and efficient fitting of the box parts, as well as to the ease and convenience with which the latter could be taken asunder when shell were being extracted in the field.

The executive of Cowan & Co., of Galt, Ltd., at the present time consists of William Cowan, president; A. B. Cowan, vice-president; James H. Cowan, secretary-treasurer; J. L. Cowan, and J. Roy Cowan, directors. About 90 men are meantime employed, although the work on hand and in prospect is such as to warrant half as many more being on the payroll, were they available.

Canada Machinery Corporation

The establishment of what is now known as the Canada Machinery Corporation took place in 1872, some five years after Confederation had been accomplished. The original enterprise was known as Cant, Gourlay & Co., the individual members all of whom were practical mechanics, being Adam Cant, John Ross, John Gourlay, and William Laidlaw. In 1876 the personnel of the concern underwent a change, John Ross and William Laidlaw withdrawing from the partnership. The present site of the plant was built upon during the same year, the previous location occupied being on Water Street North.

In 1881, on the death of Adam Cant, R. MacGregor assumed the latter's interest, and A. G. Gourlay joined the firm. With the retirement of John Gourlay in 1886, R. MacGregor and A. G. Gourlay took over the business, the firm name being changed forthwith to that of MacGregor, Gourlay & Co. The latter was incorporated in 1895 as MacGregor, Gourlay & Co., Ltd., and continued as such until 1910, when the Canada Machinery Corporation was formed. The present officers are:—T. H. Watson, of Toronto, president; B. H. Neill, secretary-treasurer; W. Baird, sales manager, and R. M. Hamilton, general manager. The head office and parent plant are located in Galt, adjacent to the Grand Trunk Railway Depot. There, a com-

plete line of light woodworking, as well as general metal-working machine tools, are designed and built, the range and variety type covering such exacting re-

Tool Co. of Hamilton, Ont., was absorbed by the Canada Machinery Corporation, the activities of the Hamilton plant being transferred soon after to Galt, by

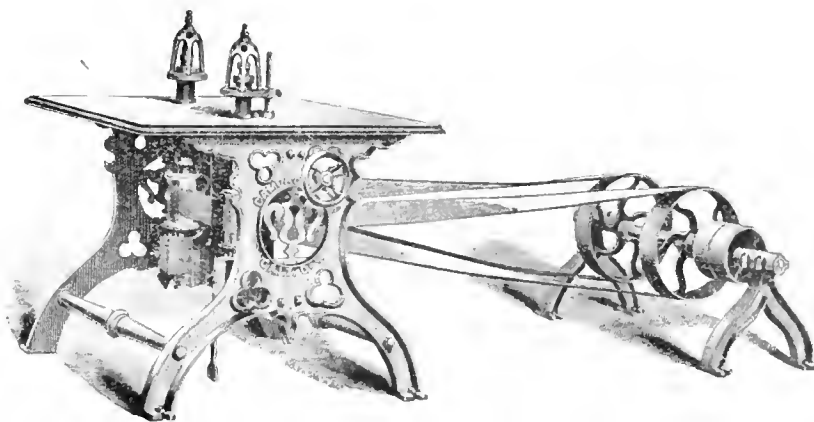

UPRIGHT SHAPING MACHINE OF EARLY CONFEDERATION PERIOD.

quirements as those of railroad locomotive and car-building shops, pattern, boiler, and machine shops, specializing or otherwise. Branch plants in operation at Preston and Hespeler, towns adjacent to Galt, are actively employed supplementing the headquarters output.

When first established, woodworking machine tools only were manufactured but with the advent of R. M. Hamilton in 1895 from the Stevens, Hamilton Co., which the MacGregor, Gourlay Co. bought out in that year, attention was given to the production of machine tools for metal-working services. Since then the two departments have gone hand-in-hand, advances made in either one appearing to pave the way for a forward step in the other, to the mutual benefit of each and the enhancement of the C. M. C. reputation. In 1911, the London Machine

removal of the equipment there, and the land and buildings in Hamilton, being sold.

R. McDougall Company

The business of the R. McDougall Co., Galt, Ont., builders of metal-working lathes, shapers, drills, pipe machines, and well pumps of a variety type and size, was established by R. Middlemass in the year 1877, ten years after Confederation, windmills, with their accessory pumps, being the particular lines undertaken. R. McDougall, who still takes an active part in the production activities of the plant which has for many years borne his name, became associated with the enterprise some two years later. From 1879 to 1895 attention was pretty well divided between the manufacture of the Claxton hot water boiler, the already-mentioned windmills with their accessory

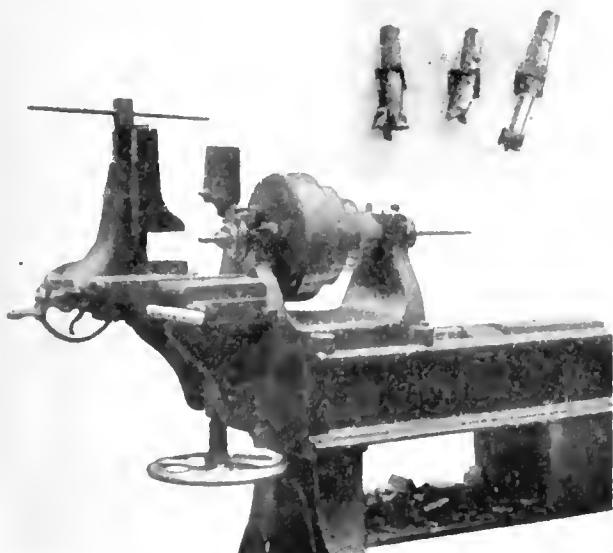

MILLING MACHINE FOR CUTTING KEYSEATS IN SHAFTS. BUILT A FEW YEARS PREVIOUS TO CONFEDERATION



RATCHET AND BRACE IN SERVICE 46 YEARS AGO.

pumps, and well pumps for hand operation. In the latter year, however, the production of metal-working machine tools was commenced, and in the interval which has elapsed success has crowned

ary. In Dundas, Ont., it was otherwise, for there the manufacture of wood and metal-working machine tools started off when the partnership between John Bertram and Robert McKechnie was

completed his apprenticeship, matrimony next engaged his attention. Miss Elizabeth Bennett, of Innerleithen, as a result became Mrs. John Bertram, and very soon after, in the year 1852, both set sail

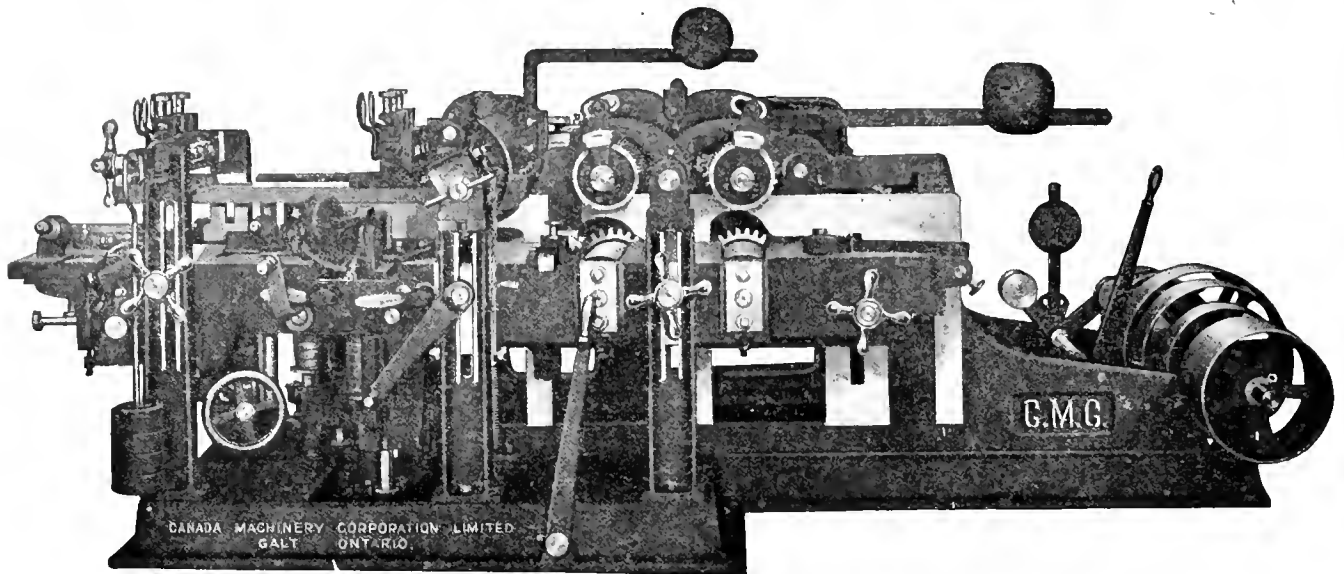

MODERN TYPE MOULDER—COMPARE WITH THAT OF EARLY WOODWORKING MACHINE TOOL PERIOD.

the departure then made. The line of engine lathes manufactured embraces from 16 in. to 26 in.; gap lathes, 26 in. to 48 in.; and shapers from 16 in. to 24 in. About 130 men are regularly employed. As in the case of all other machine tool builders, the McDougall plant has during the past two and a half years been pushed to the limit of its capacity to meet the munitions machining requirements.

formed in 1861. A small jobbing shop established by the latter had commenced operations a few months previously. McKechnie was a young patternmaker who had graduated from the Dundas foundry of the John Gartshore Co., and who had struck out for himself in a small way to carve a career in the then growing Province of Ontario.

John Bertram was born in Eldelston,

for Canada aboard the Allan Line vessel Clutha, arriving in due course at Montreal, from which they continued their journey to Toronto. When in Toronto, Mr. Bertram was advised to sail on up to Dundas by way of the then new Desjardin Canal, which he did. A noteworthy circumstance relative to the foregoing is that the whole journey from Edinburgh, Scotland, to Dundas, Ont., was made by

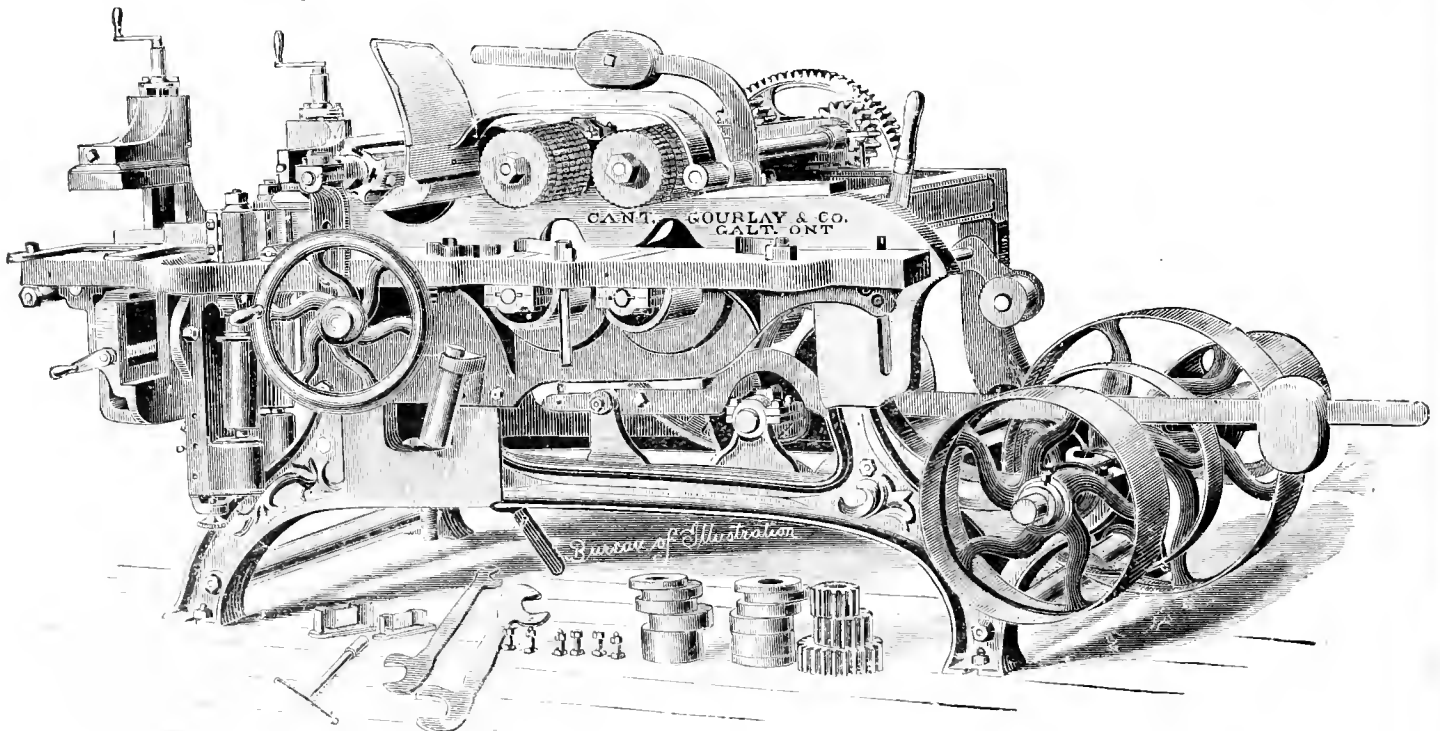

MOULDER EARLY WOODWORKING MACHINE TOOL PERIOD.

John Bertram & Sons Co., Dundas, Ont.

From what has preceded, it will be clearly evident that the initiation of Canada's machine tool industry, in so far as Galt, Ont., is concerned, was evolution-

Scotland, in the year 1829. His early education completed, he became apprentice millwright to his uncle, Thomas Aimers, manufacturer of engine and mill machinery, in Galashiels. Having

water. Having settled on terra firma again, he took a position in the shops of the Gartshore Co., who were then probably the largest manufacturers of marine engines and boilers in Western Ontario,

many of their products being installed in steamers plying on the old Desjardin Canal. Among others of the large undertakings carried out by the Gartshore Co. may be mentioned the Hamilton, Ont., waterworks, which are still in existence.

John Bertram, besides being well educated, was a skilled craftsman, and was possessed of an inventive turn of mind, as the following incident will serve to demonstrate. While employed in the Gartshore foundry, he operated a New Haven lathe which was equipped with a chain feed. This chain ran the full length of the bed, and was not accurate for thread cutting. From this lathe he designed another, but equipped with a rod and screw feed, his effort achieving what was probably the first lathe of its type to be built either in Canada or the United States, for the reason that the New Haven machines were up-to-date and most modern in style. The first of the Bertram designed lathes built had a 12-in. swing and a 6-ft. bed, and was taken when com-

Street front; later a moulding shop was built in the rear and, as business continued to increase, another two-storey building was put up, extending from the

to greater business development effort; others, also realizing that there was opportunity offering, embarked in the same line with more or less success.

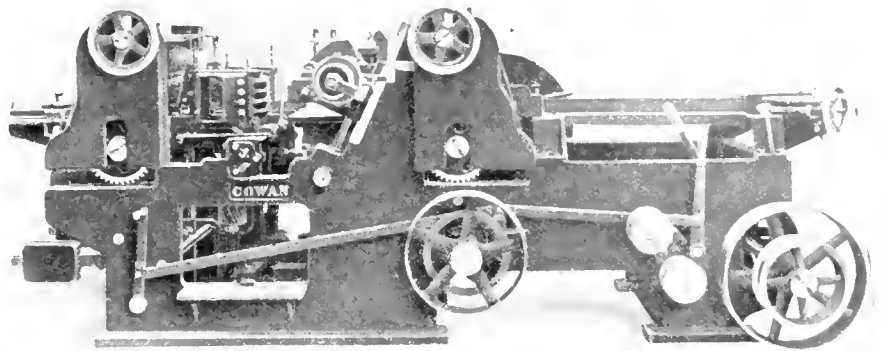

MODERN TYPE PLANER AND MATCHER.

front on Hatt Street and enclosing an area of 80 ft. by 111 ft. The firm title of McKechnie & Bertram was continued until 1886, when the partnership was dissolved. Since then the works have been operated under the firm name of the John Bertram & Sons Co., Ltd.

The difficulties under which the first Bertram lathe was built were increased because of the fact that similar shops to that of McKechnie & Bertram were like it, small, and were not possessed of the necessary equipment with which to plane the bed. A way out was found, however, at the Gartshore foundry, in which plant in use there was built in Scotland and, of course, had a table of sufficient length to plane the lathe bed without a shift. It took about six months to finish the lathe, which, by the way, weighed about 600 lbs. when complete. Much of the turning of the smaller parts was done by hand tools, as there were few self-acting lathes available, and certainly none were to be found in the Canada Tool Works. All the gears—change gears included for screw cutting—were cast from wood patterns, and all the castings entering into the construction of the lathe were made at the Gurney Foundry in Hamilton. From the modest beginning indicated, McKechnie & Bertram were encouraged

McKechnie & Bertram Planers

Following their initial achievement in lathe building, McKechnie & Bertram essayed the design and construction of planers and drills. Construction of planers was, however, beset with more or less difficulty, for the time being at least, as recourse had to be taken to the planer at the Gartshore foundry in order to have the necessary machining done. This planer, to which reference has already been made, had a 12-ft. table, and measured 3 ft. between the housings. Driving was accomplished by means of a screw. The table was so twisted, however, that the beds of the McK. & B. planer products being machined, had to be afterwards both filed and scraped. Before tracing the development of the machine tool industry—more particularly that phase of it dealing with operations on iron, steel, and metals, for, due to the rapid and steady demand for equipment of that nature, woodworking machine tool building was wholly discontinued at an early date, and the activities of the firm confined entirely to the other—it seems in order to make not only further reference to the principals of the Canada Tool Works, but also to the later activities of some of its employees.

Dundas Personalities

At about the same time as metal planer

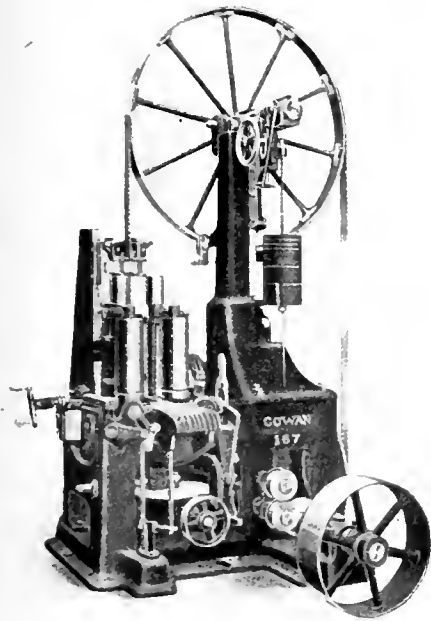

MODERN TYPE BAND RESAW. CAPACITY 3/4 IN. TO 6 IN. HORIZONTALLY, AND 26 IN. VERTICALLY.

pleted to the Hamilton Exhibition, held at that time in the old Crystal Palace. It was the only machine of its type exhibited, and of course took first prize. McQuiston & Co., who had a machine shop near the Royal Hotel, Hamilton, bought this exhibition lathe.

In 1865, two years preceding Confederation, the Canada Tool Works, by which name the plant of McKechnie & Bertram was known, consisted of a small frame building 24 ft. by 40 ft. A few years later this structure was accidentally burned down, and in its place there was immediately erected a rough cast building measuring 60 ft. long by 40 ft. wide. Continuing from this building, a brick structure, two storeys high and extending to Hatt Street, was erected in 1866. Eventually an addition of two storeys high was erected along the Hatt

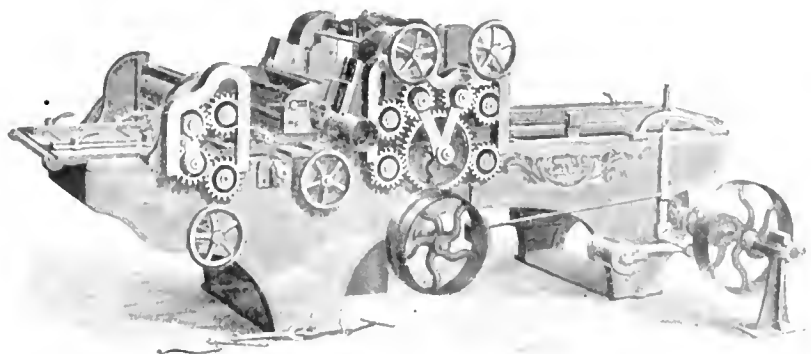

PLANER AND MATCHER OF EARLY CONFEDERATION PERIOD

production was undertaken by McKechnie & Bertram, a shop-mate of John Bertram, by the name of William Gibson. undertook the manufacture of iron tools and set up business for himself in Dundas. From the use of the expression—shop-mate, it will be quite evident that the machine shop proprietors of those

Ont., his brother going into partnership with him there, the result of which was the laying of the foundation of what afterwards was known as the London Machine Tool Co., of Hamilton, Ont. Reference has already been made to the absorption of the latter by the Canada Machinery Corporation of Galt. James

turers' Association, and with Sir John A. MacDonald, James Cowan, of Galt, Frederick Nichols, then a young man and secretary of the C. M. A., and a number

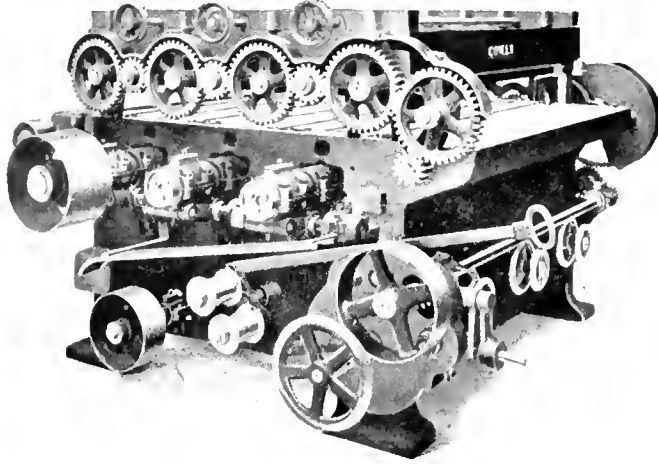

UP-TO-DATE TRIPLE DRUM SANDER.

early days took their place at the bench, at the machine, or on the erecting floor along with the regular payroll employees. Gibson completed a planing machine, but his Dundas venture was not, generally speaking, a success. From Dundas he moved to Oshawa, and later to Mitchell,

Littler and John Maw, also employees of the firm, started out for themselves and achieved considerable success for a number of years; they, however, finally sold out, and took up other lines of effort.

Robert McKechnie was one of the first presidents of the Canadian Manufac-

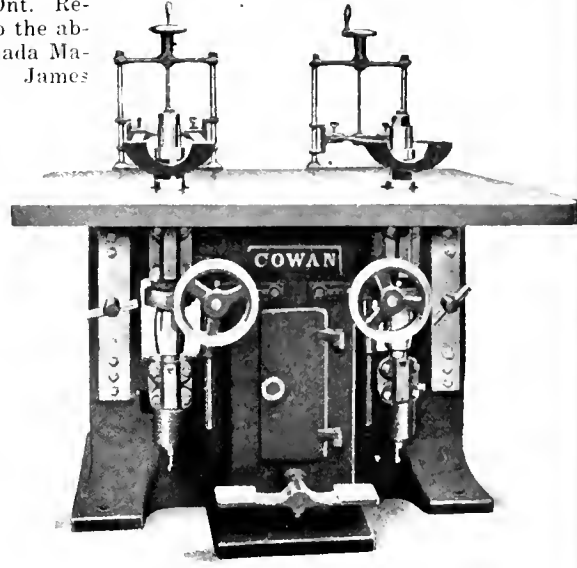

UP-TO-DATE HEAVY DUTY SHAPER.

of others, was instrumental in framing what is known as the National Policy of the Association.

In the political and commercial life of Canada, the district around Dundas furnished not a few men who later came into considerable prominence, among whom

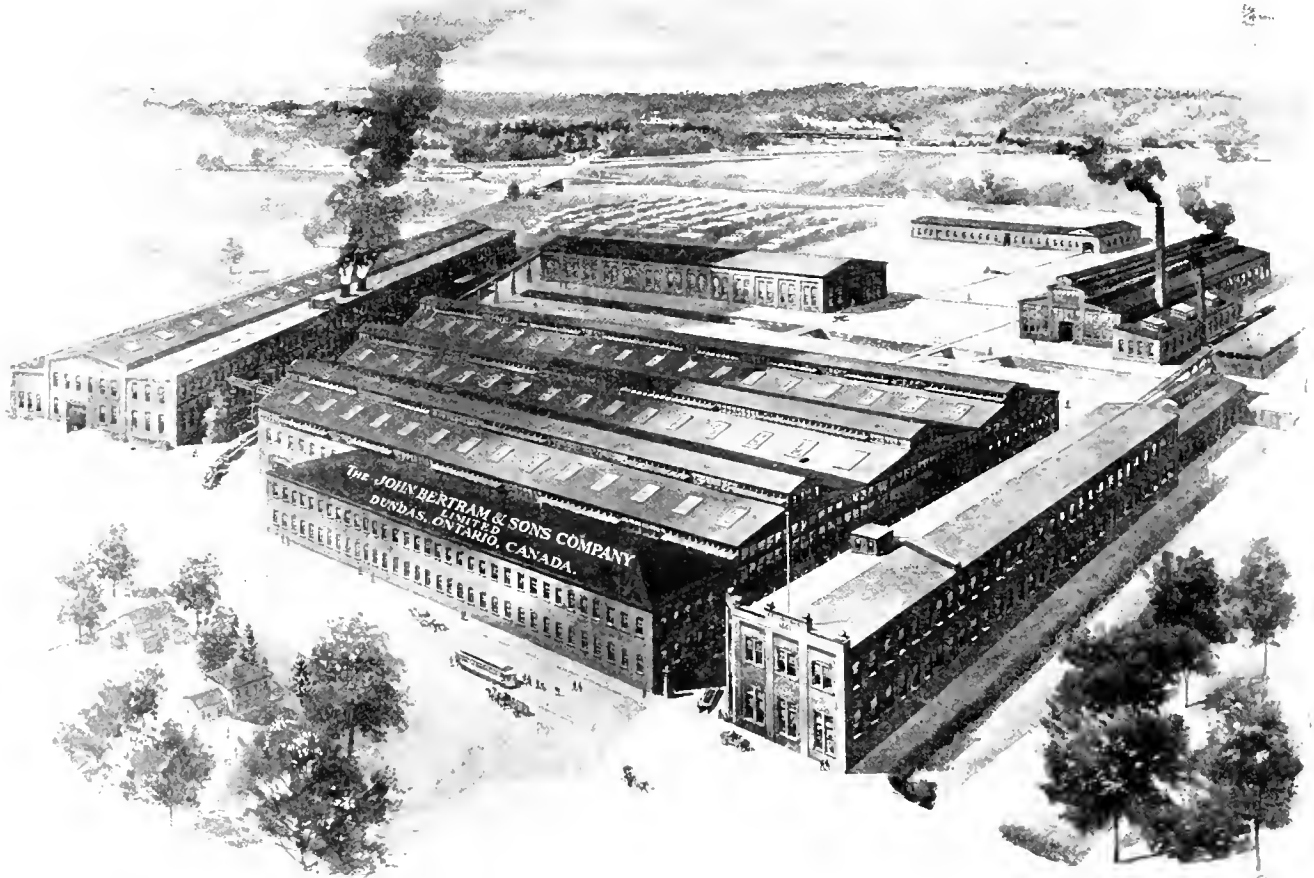

PLANT OF THE JOHN BERTRAM & SONS CO., DUNDAS, AS IT APPEARS TO-DAY.

may be cited the Hon. Robert Spence, first Postmaster-General of Canada; the Hon. William Notman, who was known as the "Orator of the West"; the Hon. Adam Crooks, the Osler and McMahon

change of firm name to that of the John Bertram & Sons Co., has been largely that of the development of Canada's metal-working machine tool industry, hence the more specific references in

ing plug and ring gauges for such services as sizing the bore of wheels and pulleys, and the turning of shafts. He also saw the necessity of employing cut gears, to which end he designed and

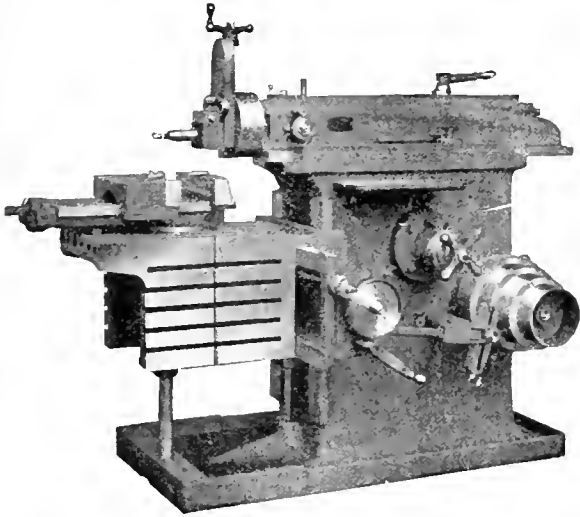

24 x 30 CRANK SHAPER

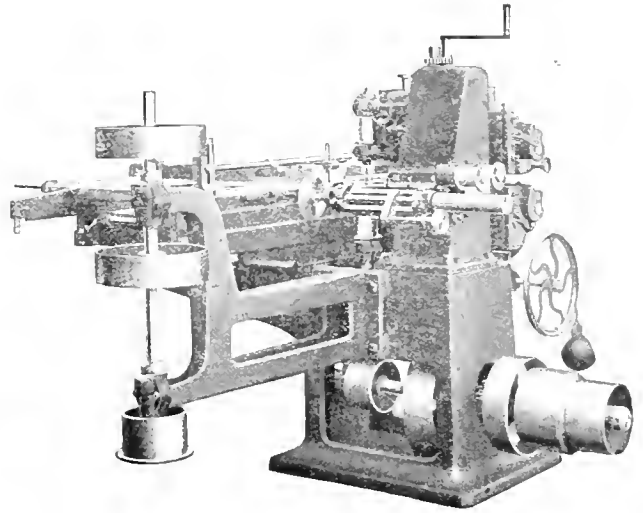

TENONING MACHINE.

families, Brig.-Gen. Sir Alexander Bertram, etc. To John Bertram was the organization and establishment of the Dundas Mechanics' Institute due, which quite early in its career became famous for its debating club and kindred activities.

Metal-Working Machine Tool Development Features

In the development of Canada's metal-

what follows to the Bertram product.

Being a mechanic with advanced ideas as regards achievement, John Bertram was apparently never satisfied with things as they were, being always at work on improved designs of product and looking to greater efficiency of plant organization and operation. It is interesting to note that quite early in his business career he set about the introduction

built a gear cutter. This machine was of quite simple get-up, consisting of a bracket bolted to the shop wall, and carrying a mandrel and dividing plate. A man was trained to feed the cutter slide up and down, but it is recorded that he often made a slip and spoiled the gear as a result.

All keyways in the early days of the Bertram plant were cut by hand, and we

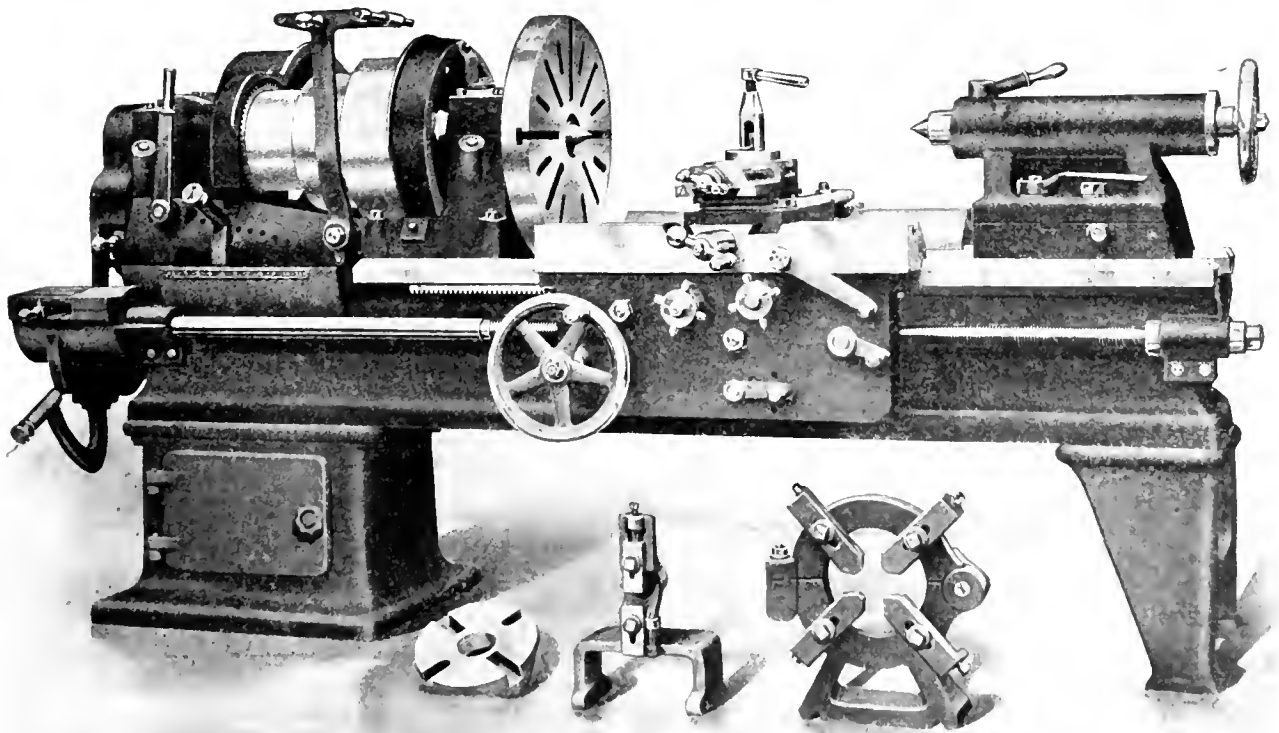

STANDARD LATHE FOR SHELL MAKING AND GENERAL MACHINE SHOP WORK

working machine tool industry, the progress record of the McKechnie & Bertram partnership—followed later by the

of such aids to shop practice as Whitworth standard threads for taps and dies, besides recognizing the utility of employ-

are informed that not only was the quality of the work performed of remarkable precision and neatness, but the time

taken in cutting small keyways compares very favorably with present-day methods, when account is taken of the setting-up and machine preparation re-

quired to do the work. For duplicating keyways in change gears for screw cutting, a broaching tool was employed, the broach being driven through after the keyway had been roughed by hand, thus producing a standard finish which at least served the purpose. A milling machine for cutting keyways in shafts, and in which the various movements were hand controlled, may be said to constitute the next development of importance.

given, and have improvements been more numerous and far-reaching, since the early "sixties." Then, we understand, it was considered quite satisfactory to furnish a 24-in. lathe with a flat shear bed, having single ribs connecting the ways together, a headstock having a four-step cone, a 2½-in. belt, and a gear ratio of something like 5 to 1. The spindle front bearing was 1¾ in. in diameter and ran in cast iron bearings; cast teeth were common to all the gears; the carriage or saddle had no power cross feed; the front apron was fitted with running gears of the most simple type; the lead screw nut

constitutes the now extensive group of metal-working machine tools.

A type of lathe built until about the year 1885 was known to the trade as the flat shear engine lathe, the top of the ways of the bed having a flat surface. The carriage or saddle containing the tool block was gibbed at both front and rear to the ways of the bed on which it had its bearing. The ways were planed to an angle of 55 degrees. The swing

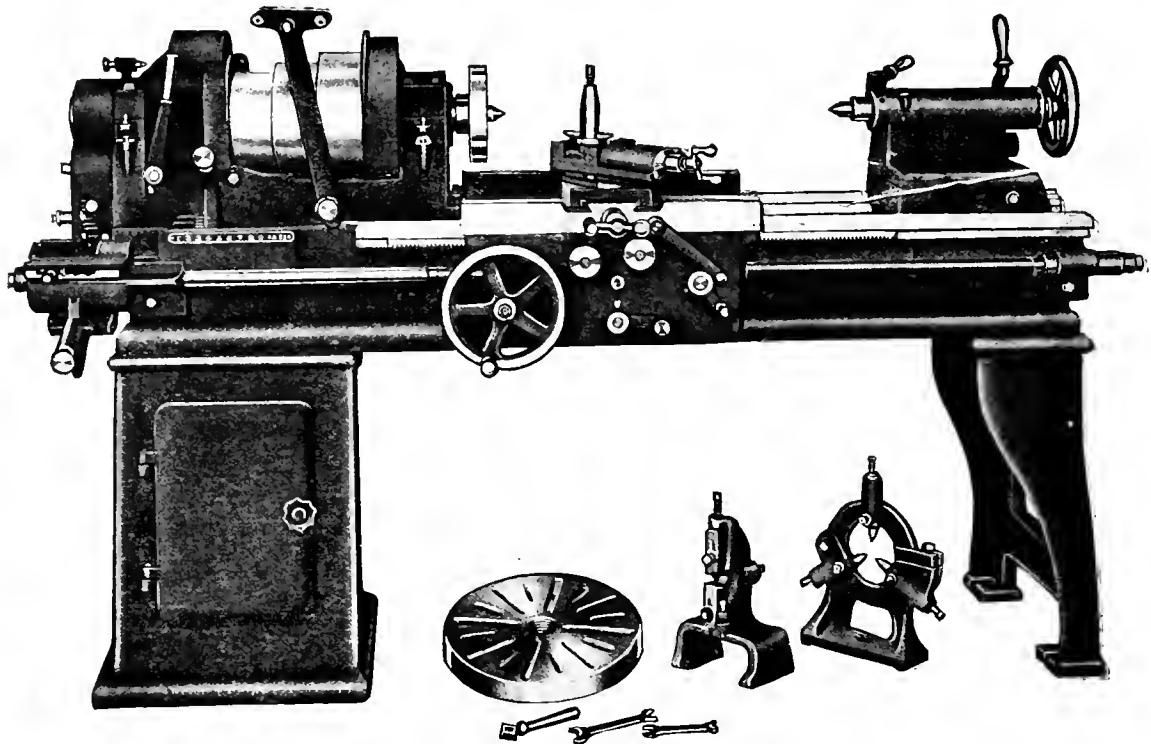

16-INCH QUICK-CHANGE, DOUBLE BACK-GEARED ENGINE LATHE.

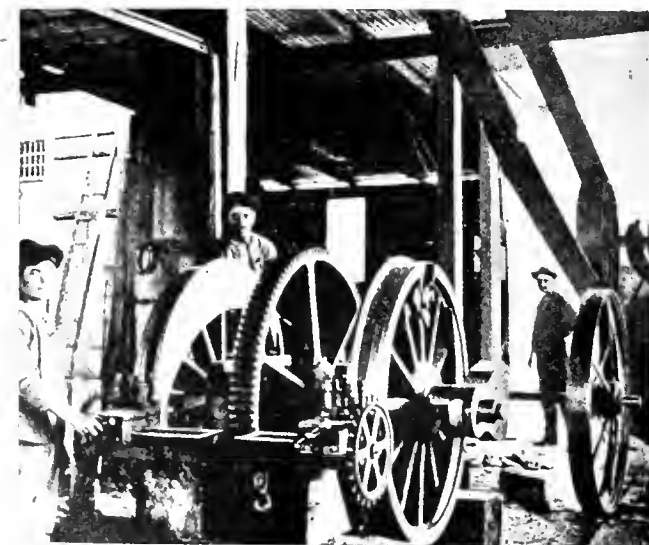

CURIOSITY IN WHEEL LATHES USED ON A BRANCH RAILROAD IN MEXICO.

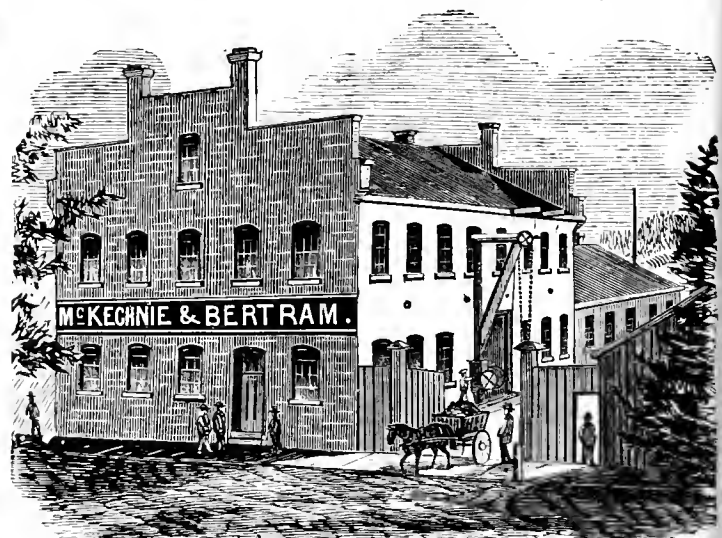

A CANADIAN MACHINE TOOL PLANT IN 1867.

Turning Lathe Development
To the turning lathe, perhaps more than to any other unit of machine tool equipment, has special attention been

was of babbitt, and the tailstock was fitted between flat ways. From the immediately foregoing sentences, and in the light of present-day achievement, it will

capacity was equal to 24 inches in diameter. The cone and gear power were limited, however, when compared with the high speed machines of to-day.

In the early "seventies," two types of lathe head construction were freely discussed by machine tool mechanics in Canada. The conical or solid bearing appealed to many by reason of its easy adjustment for wear; however, one

immediately follows, a few of the advantages are enumerated.

Employment of the motor drive does away with the overhead line shaft and its maintenance, and since belting and the line shaft need not be considered,

advantage as compared with changing the belt on the steps of a cone driven lathe. Again, in this as in all motor

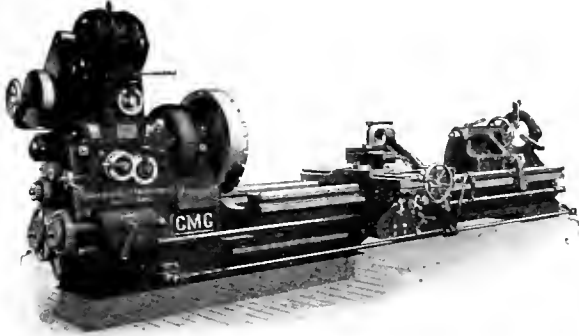

MOTOR-DRIVEN 36-INCH TRIPLE-GEARED ENGINE LATHE.

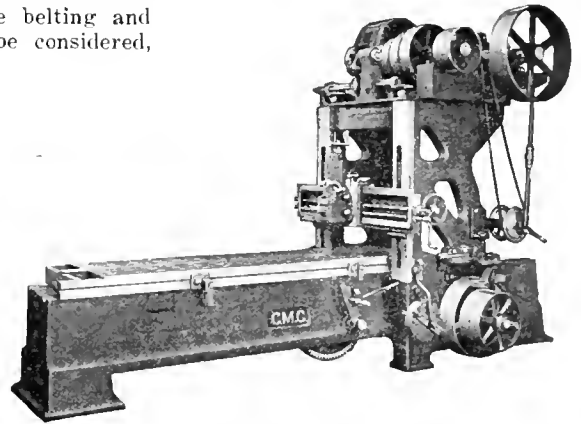

MOTOR-DRIVEN METAL PLANER.

element seemed to have been overlooked by those so impressed, and that was the matter of the expansion and contraction of the spindle under varying temperatures. This feature decided the fate of the conical bearing as constructed at that time, for although a number of English lathe builders hardened and ground both the spindle and the bearing, such procedure did not overcome the tendency to seizure, therefore the parallel front and back bearing in lathe head construction was later adopted by practically all builders.

Motor Driven Lathes

The introduction of the motor drive for lathes led to a classification which was known as the "convertible" type, the constructional features being such that a machine could be converted from belt to motor, or vice-versa as required, the gear and cone ratio permitting the use of standard motors of variable speed. When so arranged with motor drive attached to the running gear, the lathe head lost all resemblance to that of the original machine. The tendency, however, was for it to begin to supersede the cone driven lathe, and more particularly

the machine may be placed to greater advantage in the shop and space thereby be economized. The range of speeds which are obtained by variable speed motors through drum type controllers enables the operator to arrange the cut-

driven machines, the cutting speeds and feeds are materially increased, the power delivered at the cut by the motor being from 50 to 100 per cent. greater than the power obtainable in a belt driven machine; also, the absence of belt pull on

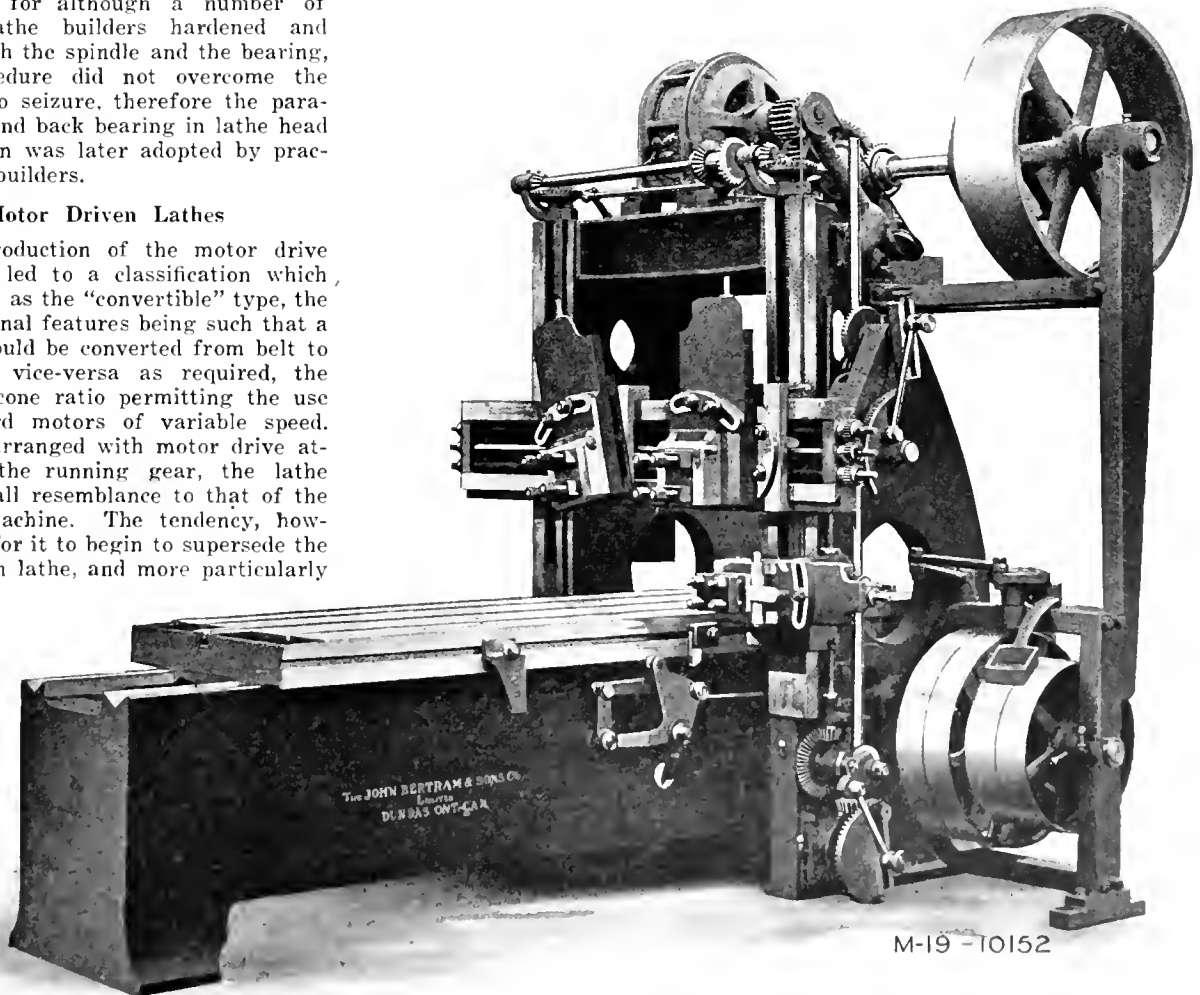

36" x 36" STANDARD MOTOR DRIVEN IRON PLANING MACHINE

in sizes running from a swing of 30 inches and upwards. Of course it is but reasonable to assume that some manner of gain was to be derived from the employment of motor drive, and in what

ting speeds to suit the material being machined. The speed variation is accomplished on the part of the operator by simply moving a handle which is conveniently located, a readily appreciated

the cone gives greater accuracy to the work being produced. The introduction of high speed tool steel has been responsible for increasing the output of motor driven lathes all the way from 30 to 50

per cent. and due to the latter feature, development has been in the direction of making all parts of these tools proportionately heavier.

(2)—The compound rests which carry the cutting tools are mounted on the bed and are held by four bolts in T-slots; in this way any springing tend-

motor directly attached. As already stated, the original machine was capable of turning out six pairs of tires per day, but upon motor drive being added, the power was increased to 20 horse power, and the output increased from six to eight pairs of wheels per day, with one man as operator and one man as helper to roll the wheels in and out of the machine. For a number of years this was considered a standard day's work, but soon the energetic shop managers of the leading railroad companies increased the horse power to thirty, with the result that the output was increased to twelve pairs of wheels per day, this necessitating an additional helper to roll the wheels in and out of the machine. Not content with this progress, however, the power was further increased to from thirty-five to forty horse power, the output thereafter averaging 14 pairs of wheels per day, with two operators and two helpers. This while demonstrating the possibilities of the machine, also demonstrated to its manufacturers the fact that labor-saving devices must be added, the output having reached the limit of human endurance.

The first step in the direction indicated consisted of a new design of tool block



PLANT OF CANADA MACHINERY CORPORATION.

Motor Driven "All-Geared" Type Lathe

Tracing still further the progress record of engine lathe construction, that of the motor driven "all-geared," warrants some attention. The drive in its case was by constant speed motor or single pulley drive by countershaft. All changes of speed are effected by clutches, no changes of belt as on a cone being necessary. The construction was such as to commend it to users of lathes of very large size, although the number of gears necessary. The construction was such as furnished the groundwork of an argument unfavorable to its installation.

Locomotive and Coach Wheel Turning Lathes

Railroad progress and development may be said to have been responsible for the introduction of the locomotive and coach wheel turning lathe, the original design of which we are given to understand was to the credit of the Pond Tool Co., Plainfield, N.J. As first built, it was belt driven of about 9 horse power, and capable of an output of six pairs of wheels per day of ten hours. The special features of this are as follows:—

(1)—The central drive feature known as the worm drive. The power is transmitted direct from the cone shaft or, as the machine is built to-day from the motor to a worm and a worm wheel, which is mounted on the end of the driving shaft. The end of this main driving shaft embraces a worm which in turn engages a large worm wheel in the centre of the machine. Both worms and wheels run in oil tight cases, which ensures perfect lubrication. In this way the power reaches the machine midway between the wheels, and, in addition to securing uniform power, the central drive makes it possible to support the wheels on both sides, the latter being accomplished by means of self-centering chucks which grasp or grip the axle journals, while chuck jaws engage the tires.

ency is prevented, and in consequence the heaviest cuts can be carried. The machine has undergone radical changes,

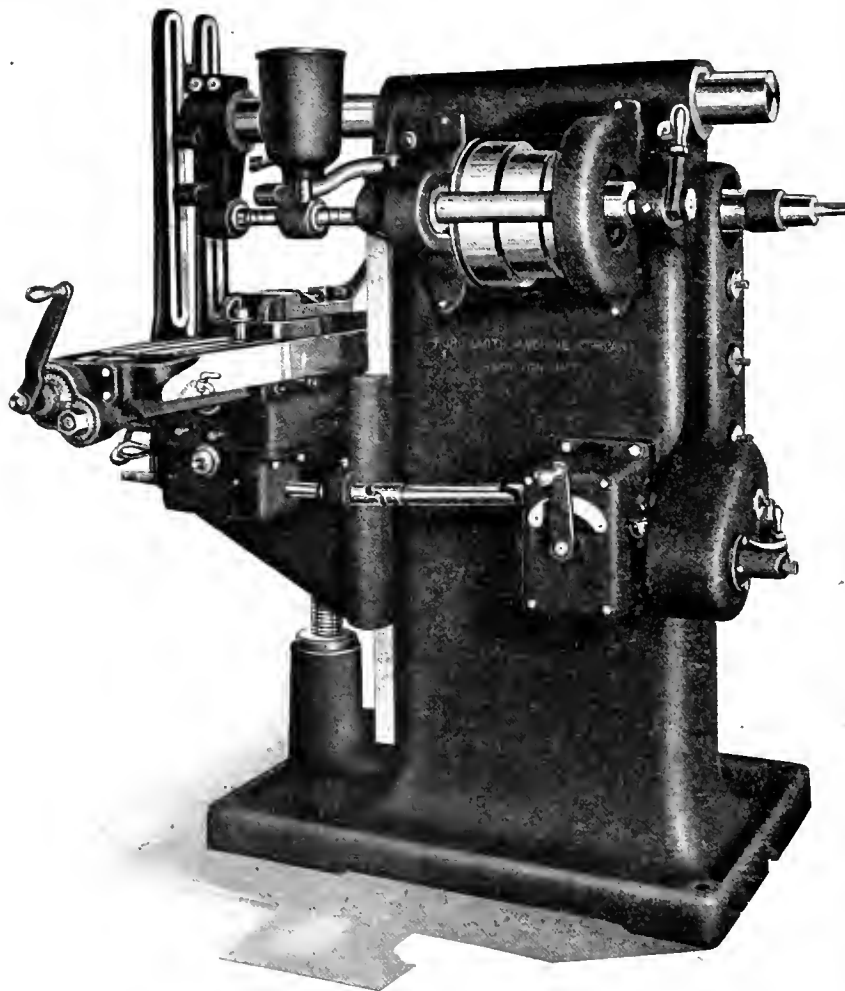

RECENTLY DEVELOPED CANADIAN DESIGNED AND BUILT MILLING MACHINE.

these having been brought about by the introduction of high speed steel and the use, for driving power, of an electric

clamping device for holding the tool, same being operated by compressed air to facilitate the work of the operator.

Power was also applied for both moving and clamping the heads on the bed. Next a segment in the central driving gear, which opens, closes, and locks auto-

the use of improved drivers, which hold the wheels perfectly rigid, the heaviest cuts can be carried with little or no vibration.

while, under special test, 10 pairs of driving wheels were turned out in just over 9 hours. One of our illustrations shows a cutting taken in the test referred to.



SAMPLE CUTTING FROM DRIVING WHEEL LATHE. WHEN 10 PAIRS OF DRIVING WHEELS WERE TURNED IN JUST OVER SIX HOURS.

matically as the wheels are rolled in and out, was added. Labor-saving devices embracing those indicated and others not referred to have so perfected this machine that the output has steadily increased, until something like 40 pairs of wheels per 10 hour day are now turned out.

The wheel lathe originally designed for turning the tires of locomotive driving wheels was light in its various parts, particularly in the head and face plates. The power was limited, owing to the narrow belt by which the machine was driven, and the output was consequently limited to 1½ to 2 pairs of wheels per day. The top of the bed was a flat surface, and in consequence the pedestal carrying the tool blocks had to be of sufficient height to carry the tools to the center. Owing to their length in a lathe of 80 inches, this was an extremely weak feature, as it was scarcely practicable to make them of sufficient size and strength to prevent springing. This, together with the weakness of the driving plates and the primitive method of holding and driving the wheels, accounts very largely for the small output obtained.

The more modern 90 inch driving wheel lathe has been designed throughout with a view to obtaining the greatest rigidity at the point where the greatest strain is imposed; permitting of the use of very short and stiff tool posts. The back web of the bed, not being subject to so great a strain, is low; this facilitates the handling of wheels in and out. The tool blocks are equipped with a tool-holder, which renders easier the setting of the cutting tools; the operator being thus relieved of opening and closing four nuts each time the tools are set. The feeds are positive, being operated by connecting rods attached directly to the tool block feed shaft. The head is equipped with a 50 horse-power motor; the power is transmitted through a train of gears on a 7 in. shaft to the internal gears on the face plates. As the internal gears form wide flanges on the face plates, the plates are given great rigidity, and by

In order to fully realize the improvement in the machine, it need only be stated that while the output of the

Another illustration shows a wheel lathe from a photograph taken of one in service some years ago on a branch rail-

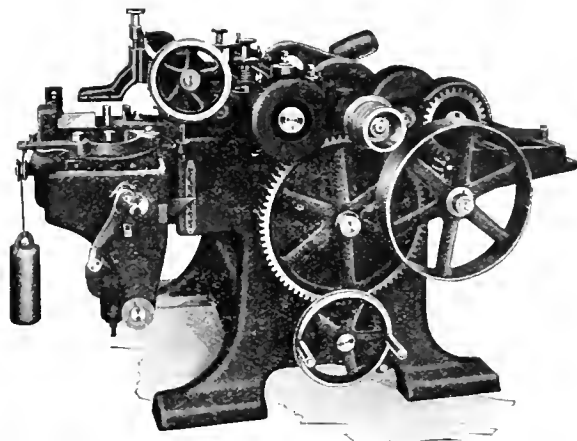

SURFACE PLANER WOODWORKING.

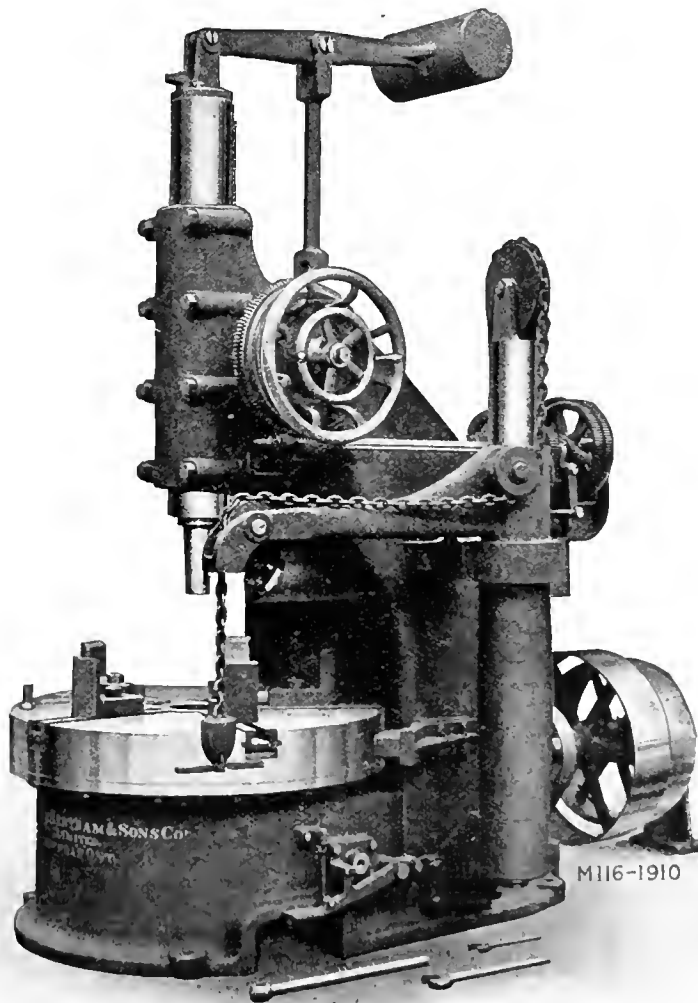

42-INCH CAR WHEEL BORER EQUIPPED WITH AIR CRANE FOR WHEELS.

earlier product was from 1½ to 2 pairs of wheels per day, the average output is now at least 6 pairs of wheels per day

road in Mexico. The bed consisted of square timbers, a main gear in halves clamped to the axle at its centre, the

wheels and axle running in their own journal. Claim was made that a pair of wheels were turned in one week, an output, however, that would hardly fill the requirements of our present day Canadian railroads.

at any time in its career has undertaken to manufacture what is generally known as a full line of metal-working machine

and the employment of high speed steel cutting tools. Speed change gear boxes, and back gears, constitute other additions to the utility of shapers in more recent years.

Few machines which have to do with the production of the modern locomotive have undergone such changes in size, weight, and power, as the frame slotting machine, nor is this to be wondered at when the increased size and weight of the locomotive of to-day is compared with that of even only a decade or so ago. Naturally there was a corresponding increase in the size of the frame to be slotted. Previous to the year 1898, locomotive frame slotting machines built in Canada had a yoke opening of 34 inches wide by 12 inches high, and a bed length of 36 feet. The slotting of one pair of forged frames in 60 hours was the capacity rating. Since then, triple head slotters have been built here, and installation is to be found in our various railroad shops. Mention may be made of those in operation in the shops of the C.P.R., and Montreal Locomotive Co., Montreal. In the case of the first named, the yoke is 48 inches wide by 26 inches high, and the length of bed, 40 feet, giving capacity to slot four largest size locomotive frames in from 32 to 34 hours.

That installed at the Montreal Locomotive Co. plant has a yoke opening of 61 inches by 34 inches, a 50 ft. length of bed, with 32 inches maximum stroke of cutter bars. This machine capacity is the slotting of six locomotive frames simultaneously. The method of driving the slotter underwent a change for the better by the introduction of the electric motor. In the triple head machines, each head is driven by a 20 horse power motor, from which the cutting bars are driven through powerful friction clutches, permitting the operators to have convenient control of the bars at all times. This improved method of drive supersedes the long shaft which ran the entire length of the bed in the earlier machines. General purpose slotters, or as they may be classed—vertical shapers, constitute also a Canadian machine tool product, and in the case of their design, smooth running and rapid and convenient handling of the work have been kept in view.

Drilling Machines

As regards drilling machines of Canadian manufacture, it may truthfully be said that if not meantime, then at some time or other during the past sixty years, standard as well as many special types have been built, ranging from the common ratchet and drill brace, one of which is illustrated, having been in service here some fifty years ago, to the highest grade pedestal, horizontal, full universal radial, and gang drill presses, belt and motor driven. Drill press manufacture in Canada has perhaps been more widely practised than has any other form of machine tool product, many firms whose work has been of the most general nature, taking a hand in some feature of this wide-range specialty from

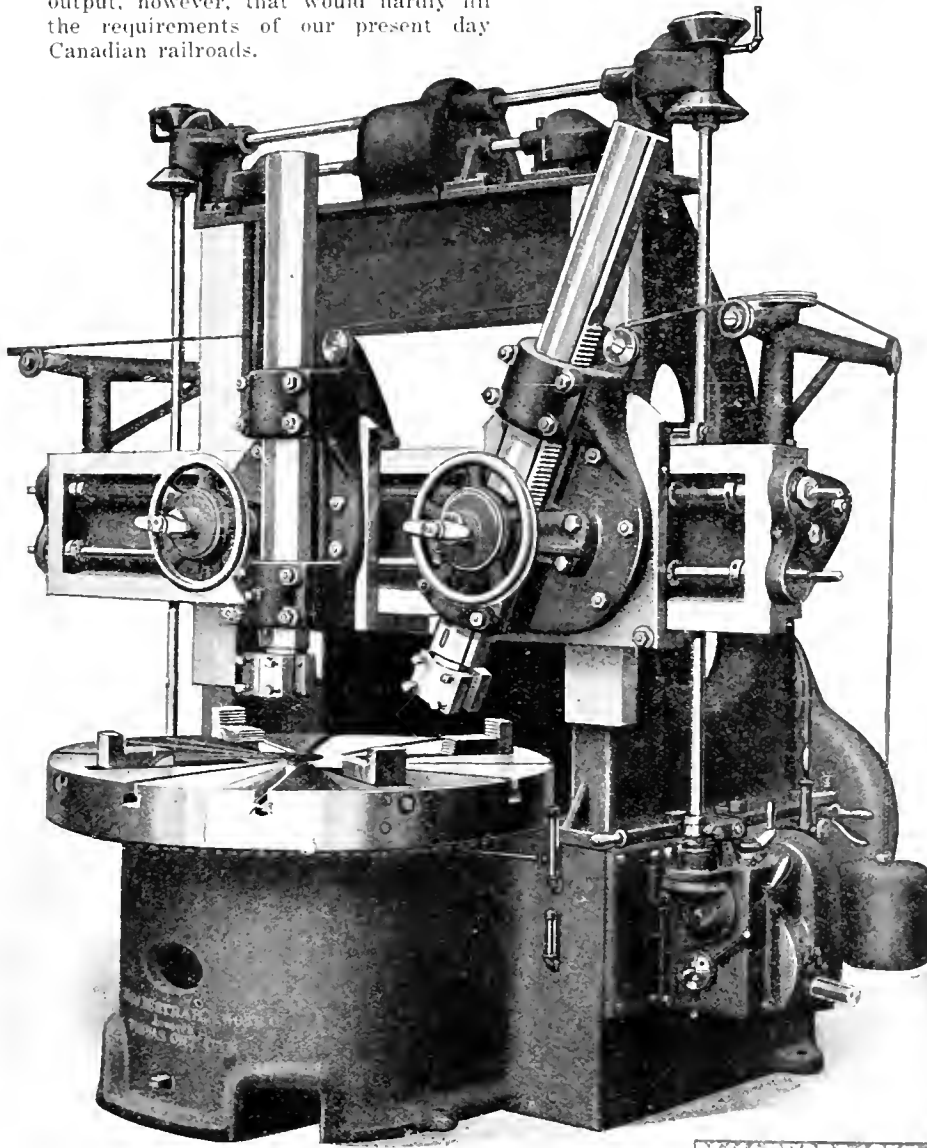

42-INCH VERTICAL BORING AND TURNING MILL.

Turret, screwcutting, and tool room lathes, also single purpose lathes as a war time product of a myriad Canadian plants, and of wide variety design and scope, may be mentioned in passing as having participated in the lathe feature of our machine tool development.

Boring and Turning Mills

Boring and turning mills, another form of lathe construction, arranged to admit of easy chucking of work pieces to the faceplate, have shared to a large extent, in a variety feature, the labor and time saving attention given, and success achieved by the different type lathes discussed. Needless to say, the tendency as in that of lathes has been also in the direction of more rigid and substantial general and detail part design and construction to meet the heavier duty requirements. It should perhaps be mentioned here that no Canadian firm

tools, nor are we aware of effort being directed to the like end elsewhere. It is highly probable, however, that the Bertram works most nearly approach that condition.

Shapers and Slotters

The shaper is a straight line cutter of the planer type and is capable of performing a large number of operations formerly done by hand. The work is held stationary and the tool given a reciprocating cutting motion. The feed motion of shapers may be given either to the cutting tool or to the work. When the feed is given to the cutting tool, the machine is known as a travel head shaper. Crank type shapers may be said to embrace the line made in the past in Canada, and in their case as with all other metal-working machine tools, progress in design and weight of parts became necessary with introduction of motor driving

the tiny bench or column drill upwards.

Metal Planers

It may not be generally known that planers belong to antiquity, nevertheless, on excellent authority we learn that little was accomplished as regards their development between the year 1694, and early in the year 1800. The planer at the Gartshore foundry already referred to had a cutting speed of 10 feet per minute, and the rack had a double section, the teeth of which were staggered to give a smooth and uniform motion to the table. One of the first metal planers built in Canada belongs to the year 1867, Confederation Year. The power was delivered to the table by a single 3 inch belt running at a velocity of 512 feet per minute, with a gear ratio of 6.25 to 1, giving an effective pull on the table of 3,750 pounds, and a cutting speed of table of 20 feet per minute. Later a 36 inch planer was built, the drive being by means of two 3 inch belts, one of which took care of the forward or cutting motion, and the other, that of the reverse motion. A belt velocity of 1,000 feet per minute, and a gear ratio of 13.4 to 1, delivered an effective pull on the table of 8,180 pounds at a cutting speed of 20 feet per minute.

From the foregoing, some idea will be had of the development of metal planers. As the years went by, modern construction demanded economy in space and a more convenient layout, which led to the adoption of individual drives by electric motor, and for a time the mounting of the motor on top of the planer housing was followed. This arrangement proved more or less faulty, due to the liability of the machine producing defective work by reason of the vibration caused by the motor location. To minimize or possibly eliminate the trouble,

production has been a comparatively simple one in such machines as lathes, drilling machines, boring mills, milling machines, etc., in which the cutting is continuous and the motion of the tool is in one direction only. In these types of machine, it has merely meant adding power, and strengthening parts. The speeding-up process introduces a vastly different problem in such machines as slotters, shapers, and planers, in which the cutting is not continuous and which have a return motion of the tool. The principal limitations of machines of this class, especially the planer, are twofold, there being first the inertia of the moving mass at the moment of reverse, and second, the speed at which the tool enters the work. The problem of overcoming these limitations has had the atten-

Grinding Machines

Grinding machines have proven to be well adapted for producing accurate work, and not only have they been found to be economical in the manufacture of machinery and tools, general and special but for duplicating parts on the interchangeable system, they are altogether unexcelled. Experience goes to show that it costs less to finish and fit work by grinding than by the old method on a lathe. Development of grinders in Canada compares very favorably both as to variety of product and its efficiency with what has been accomplished elsewhere, a circumstance which is highly complimentary to our different firms who have taken up manufacture in a specialised sense, thereby placing grinding machines, external and internal, on an equal footing with lathes, drills, planers, shapers, etc., in our metal-working industries. The attention being given to the investigation and manufacture of the abrasive constituent of the grinding wheels, and degree of success that has been achieved in these particulars, have contributed materially to the substantial nature of the different machine designs, and consequently to the accuracy and

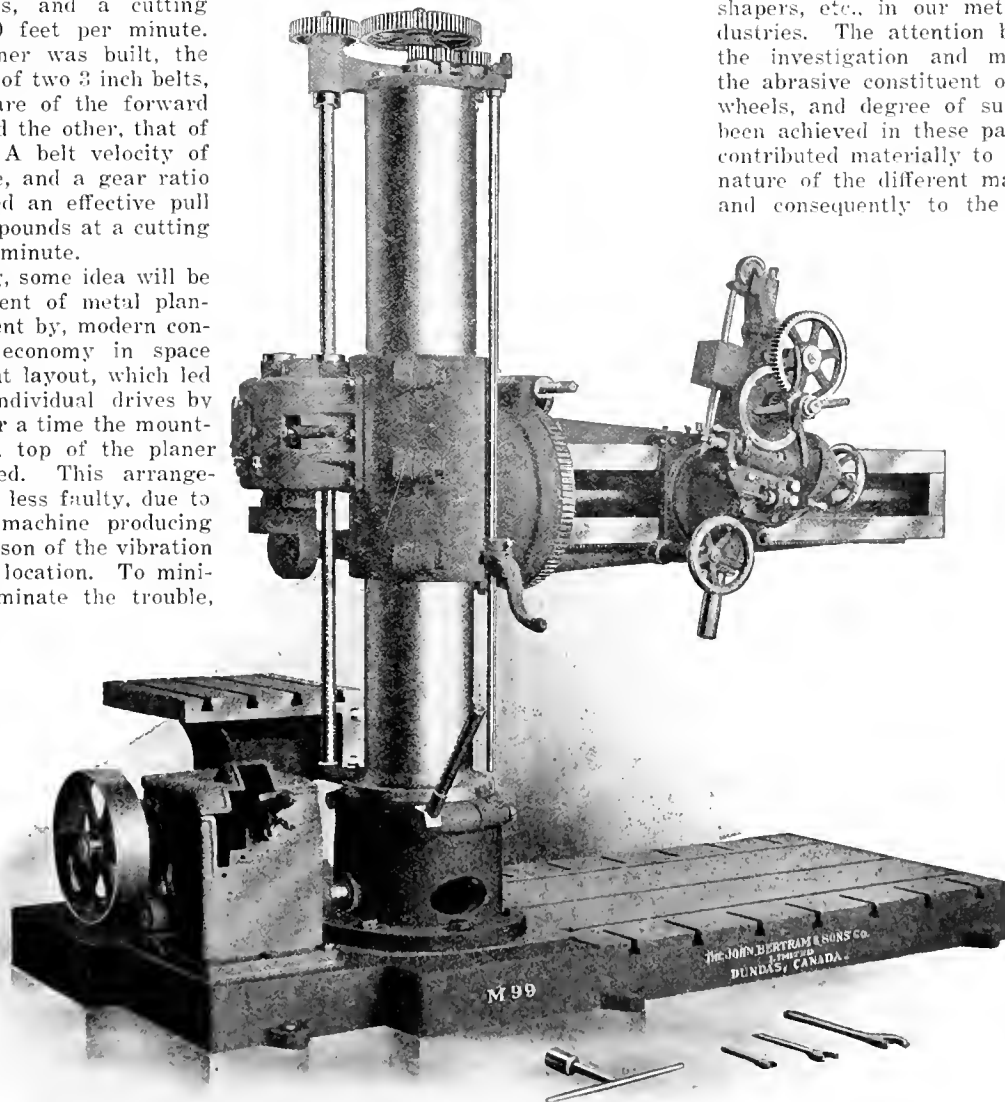

6-FT. UNIVERSAL DRILLING MACHINE.

pneumatic clutches were introduced, and the motor drive placed at the base of the housings. The problem of providing the increased speeds and power to develop the possibilities of high speed steel, and to meet the necessity for greater

quality of the work produced. As in the case of the machines already noted, so with the manufacture of abrasive materials for grinding wheels, Canada can lay claim to having several plants in active operation.

tion of quite a number of machine tool experts, and while considerable progress has been made, the complete solution does not appear to have been reached. The evolution of the planer has followed along the lines of increased table speeds.

Milling Machines

It may be taken for granted that no machine shop having pretensions to the name of seeking to keep abreast of the

ments of the twin industry. While such essentials as punches, shears, plate rolls and planers, etc., have been in the past produced here, same has been on a quite

deserved prominence, by so doing there will be given evidence that equal achievement belongs to it as does to its twin-brother—that of metal-working.

An important adjunct to the development of machine tool manufacture, whether the products be wood or metal-working, is that of the institution known as machinery selling agencies. By means of these the manufacturer is relieved both of the maintenance of a sales organization and in not a few instances of the necessity of finding work for his plant. Canada has been well served, we might say through the activities of selling agencies separate from her plant organizations, and that the agencies have maintained themselves from a date more or less well back into the Confederation Period, speaks volumes for the future welfare of the industry in its every aspect.

Before the advent of the lead screw on the early engine lathes, it was the practice, when small screws were required, to place the shafts between the lathe centers and by means of a hand tool and

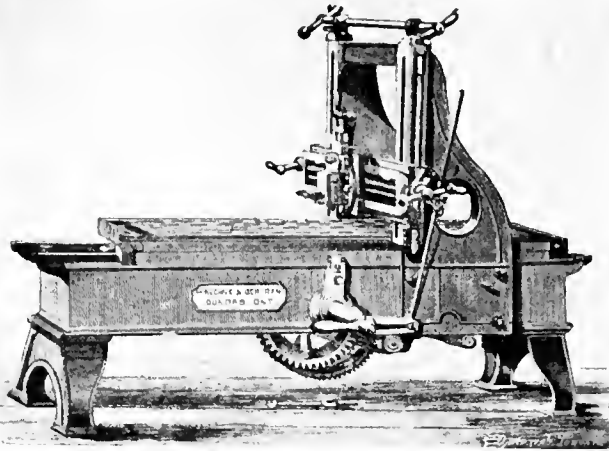

METAL PLANER BUILT IN 1867.

times is or should be without a milling machine as part of its feature equipment. An equally wide range of designs exists as in the case of the tools already mentioned, and naturally the variety of work that can be performed is commensurate. Milling machine manufacture in Canada dates well back into the Confederation period, but no very serious attempt appears to have been made by any one firm in particular to specialise until probably quite recent years. In the United States the milling machine has been highly developed, with the result that by far the greater number of those installed in our Canadian machine shops have come from there. One effect of the new vision of our manufacturing capacity that the machining of shells has produced is that we are competitively able to do what others have done or are doing; as an example, and directly relative to this milling machine feature, it may here be stated that one Canadian concern that less than a year ago started to specialize has now met with such success that milling machines are now their chief line, their output not only finding a ready market at home but abroad, shipping as they are into the United States against the tariff, also to Great Britain, Italy, India, France, Japan, Russia, etc.

limited scale, particularly as the demand has been largely to meet the needs of structural steel, tank, and boiler plants. Shipyard tools are for the most part distinct from machine tools as commonly understood, less refinement being connected with their operation. Wood as well as steel shipbuilding is being prosecuted within our borders to an extent only a little less in degree as between the former and the latter. Already steps have been taken by at least one Canadian plant to cater to the needs of wood ship construction in the shape of a ship band saw being placed on the market and, as the opportunities are many for the employment of both wood and metal-working machine tools, it will be a very short time before a full line of each to meet the situation will be developed and made readily available.

General and Personal

It is of course impossible within the scope of an article such as this to even refer in passing to the many other units of metal-working equipment, attachments, and fixtures, not only found in our machine shops generally, but of Canadian manufacture in addition. Further, although some reference has been made

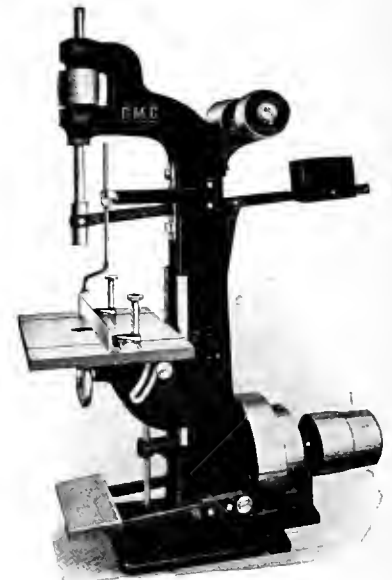

VERTICAL BORING MACHINE.

(good judgment), make a slight impression of the required pitch over the surface; when this was accomplished, the

Machine Tools for Shipbuilding

The impetus given to shipbuilding and

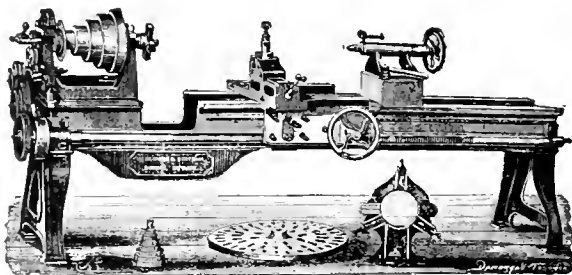

36-INCH GAP LATHE BUILT AT DUNDAS IN 1868.

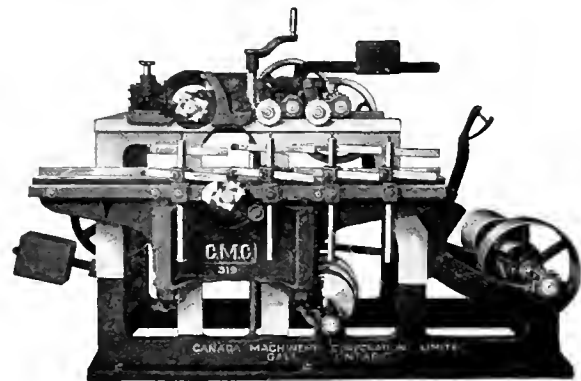

SASH STICKER.

marine engineering in Canada, due to the submarine activities of Germany on the high seas, has naturally had the tendency to direct attention to the tool require-

to woodworking machine tool production in Canada, the fringe of it has merely been stirred, however, on some other occasion its detail progress may be given

shaft was taken to the bench and a helical groove chipped by means of a chisel to conform roughly with the desired thread, after which it was again placed

in the lathe and the screw finished by using a flat chaser. Accuracy, so-called, was more of a human factor than it is now, the modern machine, irrespective of class or type being the acme of perfection, so to speak. In the early period of machine tool building, the achievement of accuracy was in the nature of an art. Many machine tools, both wood and metal-working built and installed away back as far as Confederation year are still in operation and doing good work comparatively, which indicates that they were suitably designed and constructed to give both long and efficient service.

There were boom and dull times in the early days of machine tool building just as there has been since, although due to township or district isolation, arising from the lack of railroad facilities, it often happened that the "hunger or the burst" was locational. That this was so on one occasion at any rate, and that the Canadian winters were a good deal more severe than they are now, is borne out by the story that follows:—New construction was more or less at a standstill in one of our pioneer plants, so with a view to keeping the rising generation of mechanics out of mischief, a disposition towards which had already become apparent, as also to keep them in touch with their work, arrangements were made to have them sent out individually to various firms who had been having tools built, and were themselves too busy to undertake their erection. Hot water, hot air (all kinds), and steam heat, were then unknown in Canadian hotels, as a consequence, sleeping quarters were unattractive to the extent that it is recorded of some of the "boys" that they did not undress for the period of one whole winter, and that on the occasion of a church social which no doubt had reactions common to the experience of most of us, the special dressing up meant simply the addition of a white shirt on top of the black working shirt.

The majority of the pioneers of the machine tool industry have gone to their rest, large numbers of the youths they grounded in the essentials of the craft are however still with us, and it goes without saying that their presence, and the positions they now occupy, furnish the incentive to the youth of this generation to go in and win as they have.



METHOD IN MAKESHIFTS

By J. E. McCormack

IN one instance, in the replacing of water gauge fittings after renewal of adjacent parts, the squaring up of the replaced gauge parts was done by using a carpenter's square having a sixteen-inch tongue, which, by the way, was longer than the water glass used.

When the fittings were apparently true, a glass was inserted and in a few days the third glass had been put in, the former two having broken. The fact that this number of glasses had not been broken during the two previous years altogether proved that the fittings were

out of line. Being an isolated plant, there was no proper try-square at hand. A man who had been working in a plant a few miles away called in and seeing one corner of a broken window pane lying on a box, picked it up, examined it on the carpenter's square, then with it he tested the fittings without removing the gauge glass. Through checking his observations by reversing the piece of pane frequently he detected the errors in alignment. The water glass was removed, the alignment adjusted by using the piece of window pane for a try-square, and the water glass replaced. During the following twelve months only one glass broke, and then only to the extent of a hole in one side and caused by a foreign substance of low

would have been time saved and the breakage and replacing of two extra glasses would have been avoided.



OPEN LETTER TO THE KAISER

A CORRESPONDENT of the New York Times writes the following open letter to the Kaiser, describing for his edification the advantages of the simple life on the Isle of St. Helena with its memories of other shattered dreams of world conquest.

You may go to St. Helena soon, I understand, but you are probably too busy fighting for your existence now to find much time for general reading. So I will tell you about St. Helena.

St. Helena is a pretty eight by ten island in the South Atlantic. The nearest land is Ascension Island, 700 miles away, and the nearest mainland Africa, 1,200 miles east. The best way to reach St. Helena is by boat. A battleship could drop you there and call back again once a month to see if you were all right.

The cliffs of St. Helena rise to the height of 1,000 feet, and the view from the top must be entrancing to a man who yearns as passionately for a free ocean as you do. You could stand up there and look at a free ocean for miles in any direction. As far as your eye could reach you would never see a submarine blowing up a passenger ship. The seas around St. Helena are probably the freest in the known world, and I hope you may be spared to enjoy the sight of them.

One of the nicest things about St. Helena is that it lies 4,477 miles away from England. While visiting the island you would not need to worry all the time for fear of being attacked by the soft, cowardly, rabbit-hearted English. You would not need to sleep in your spurs, with a gun under your pillow and your sword hanging on the foot of the bed, because England and Belgium would be too far off to jump on you without warning as they did so treacherously in 1914. After you had been at St. Helena a few years perhaps you would feel so safe that you could venture out in the yard without your weapons. There's no place like an island for a militarist with nerves.

St. Helena is really the lid of a volcano, but you have sat on the lid of a volcano for thirty years, so you wouldn't mind that. The climate is temperate and salubrious. The Hotel Longwood, where Napoleon stayed, is still standing. Queen Victoria presented it to the people of France some years ago, but doubtless it could be rented from the French nation. You need a good rest after your hard fight for the freedom of the seas, and I'm sure there is no place where you could get rest better than at St. Helena. The island was settled originally by pirates and about 3,500 of their descendants remain to this day, so you would have just enough congenial society without being overrun with it. Now I must close and take a run down to the bulletin boards to see if your brave little U-boats have made the seas any freer than they were yesterday.

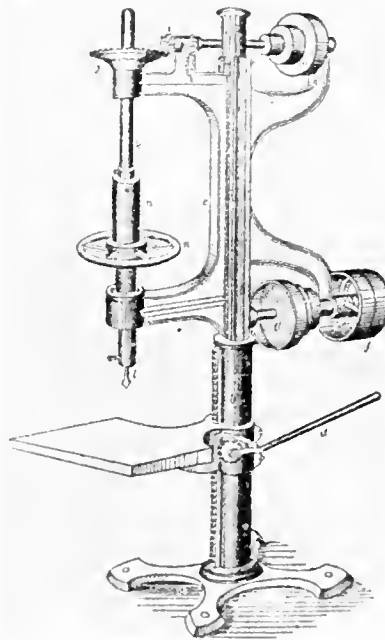

VERY OLD ILLUSTRATION OF AMERICAN-BUILT DRILL.

temperature coming against the said glass at this point.

The hint involved is, that in lining up articles for which a small try square is required but not at hand, it is sometimes possible to substitute some simple commonplace article and secure better results than could be obtained by the use of a square which though true is really too large for the amount of working room available.

By all means let us when possible have high grade tools—tools of a class designed for the purposes for which we require to use them but when we must substitute let us do so with an eye as to what can be quickly adapted to serve our purpose to the best advantage and without too much regard to actual market value so long as nothing is rendered useless for another time.

Resourcefulness counts when properly directed. Had a proper sized try square been quickly available, it would have been used in the first occasion mentioned above. The price of window pane had no market value but nevertheless it was more convenient than the square used and if it had been used at first there

PRODUCTION METHODS AND DEVICES

A Department for the Interchange and Distribution of Shop and Office Data
and Ideas Evolved from Actual Practical Application and Experience

MILLING TWELVE SIDES ON LARGE DISC

By F. Scriber.

A FIXTURE of simple design for milling flats on a large disc is illustrated by sketch, Fig. 1. The work itself is shown by Fig. 2, from which it will be noticed the disc is 27 in. in diameter.

In this instance it was necessary to make the fixture cheaply, and in conse-

quence a large angle plate A was used as a base from which to work. This angle plate bolts on to the table of the milling machine in the usual manner. On the beveled rib in the centre two machine steel blocks B were placed, these being held in place by screws and dowels as shown. The reason for putting these plates on is to build up sufficient metal for tapping into for the stud C.

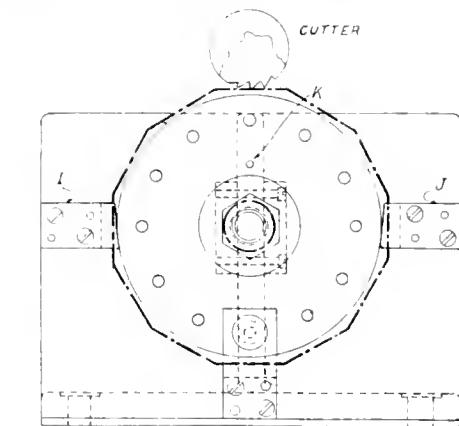

FIG. 1.

quence a large angle plate A was used as a base from which to work. This angle plate bolts on to the table of the milling machine in the usual manner. On the beveled rib in the centre two machine steel blocks B were placed, these being held in place by screws and dowels as shown. The reason for putting these plates on is to build up sufficient metal for tapping into for the stud C.

To the lower portion of the angle plate a block D is placed; this block carries an indexing plunger E. A circular plate F is used for indexing, while a nut and washer G and H are used for clamping the work in position, two blocks, I and J, at each side of the large plate F being used as braces, while the large plate F and the work are doweled together by means of a pin K.

Operation of Jig

In operating this jig the large plate is first doweled to the work, and is dropped into the position shown in the fixture where the index pin E is forced into one hole in the large plate. While this is being done, the stud C, Fig. 3, is out of the fixture. The stud is now put into position, and with the nut G a couple of turns back, the stud is securely tightened into position by means of the squared end X. This stud forms an axis upon which the work may be turned for the successive stages of milling, as will be evident from the following.

After milling one flat in the usual manner with the cutter shown above, the nut G is loosened, but the stud remains tight. Then pull out pin E and turn the

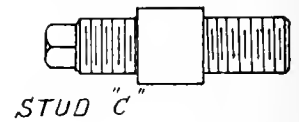
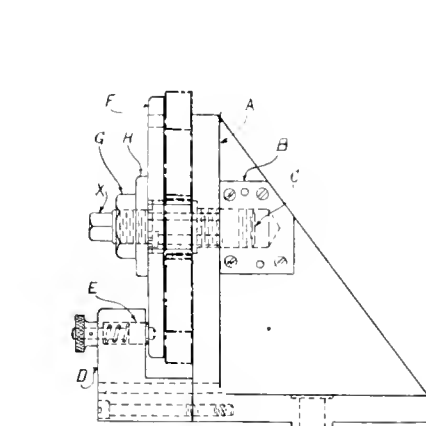

FIG. 3.

and we proceed to mill this piece in the same manner.

In further regard to the two blocks I and J, these bear against the periphery

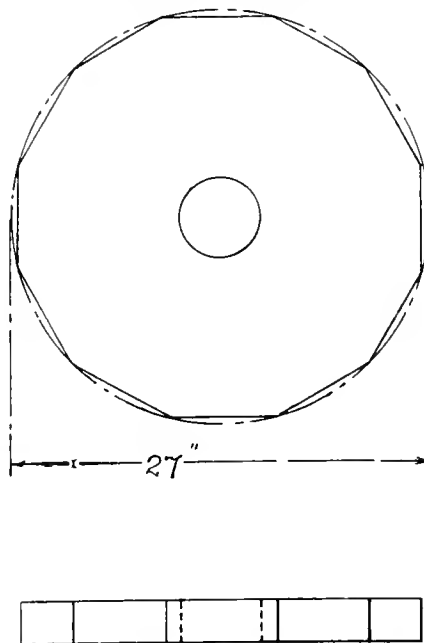

FIG. 2.

of the indexing plate, thus acting as braces to help to support the work while the cut is being taken.

One big advantage in having this fixture built up as shown is that the vari-

ous members may all be removed from the angle plate when the job is done, after which the angle plate may be again used for any purpose for which an angle plate is suited.

EYE-STRAIN AMONG DRAFTSMEN

By E. V. A.

EYE-STRAIN is a common complaint among draftsmen. It is a common fallacy that the constant use of the eyes in making drawings tends to weaken them. Experience and study has shown that there are other causes, more or less

due to carelessness and thoughtlessness, which contribute to a considerable extent in weakening the eye-sight.

First of these is, working in a too glaring or inadequate light, this latter especially on stormy or cloudy days. Using lead pencils that are too hard, and which produce only light faint lines on the drawing. Using drawing paper that is too dark, making it difficult to observe the pencil-lines through cloth or paper when tracing.

While draftsmen may sometimes exercise no choice in the selection of paper and degree of hardness in pencils, it is necessary that those in charge of purchasing materials should be really careful to select only white drawing paper if tracings are to be made from it, or, if the penciling is to be taken directly from the board for use in the shop, the paper should be the lightest drab-color. Also pencils of various degrees of hardness should be kept on hand.

Pencils Should Suit Paper

The point to be emphasized is, that when paper of a drab-color is used, a lead pencil marked 3-H, or 4-H, should be used. Drawings that are to be traced should never be made with pencils of extreme hardness. The lead in a compass should always be one or two degrees softer than the pencil used, for the reason that one cannot bear down with sufficient weight with the compass to make arcs and circles equal in heaviness to the pencil used.

Modern drafting-room practice should not tolerate fine light lines on drawings. The day of fancy drawings made with web-like hair lines is passed. A blunt point on a pencil is far more serviceable—produces real "seeable" drawings—than the fine needle awl-like points that are commonly used. When inking a tracing, the lines should be made as

heavy as possible. Figures and lettering, the most important part of a drawing, should be made large and "readable." Blueprints made from such tracings are much more appreciated by workmen who use them. Since no two persons' eye-sight is alike, it is readily seen that when the lines, figures and letters on blueprints or drawings show "big" the person with the weakest sight will be able to read them.

Another point that should be given careful attention is, that after a drawing is checked up particular notice should be taken to see that all lines, figures, etc., are sufficiently heavy, and where any are not, they should be returned and retraced for this purpose. Absolute plainness and simplicity should be the rule in making drawings. No drawing should be marked "approved" unless the points as described have been thoroughly examined to see if these have been properly rendered.

MACHINISTS' INSTRUCTION COURSE—XXII.

By J. Davies.

THE sector is a device for correctly dividing or measuring off a certain number of holes and is used in connection with the index plate. It is a labor saving device, and is designed to prevent any mistake in counting the holes. The sector consists of two radial arms, so constructed that they can be set at any distance from each other and locked in position. Fig. 82 shows how the sector is used; to avoid any confusion the index plate in illustration only shows one row of holes.

We will suppose that the index crank has been adjusted and the circle of holes shown is the one selected. The latch pin is brought into the right position for a start, and put into one of the holes. Next

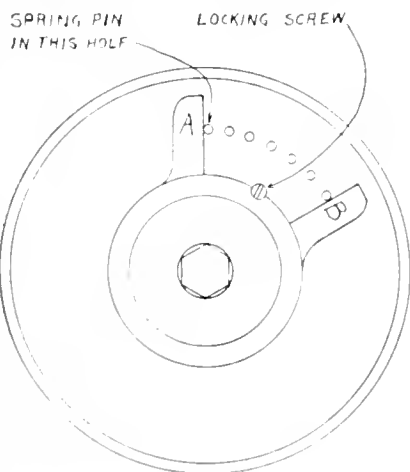

FIG. 82.

bring the arm A against the left side of the pin, then move the arm B forward the requisite number of holes and lock it in position. The illustration shows that the arm B of the sector has been moved forward 6 holes. Suppose it is required to use one whole turn plus 6 holes, referring to Fig. 82, the spring pin is withdrawn from the hole next to arm A,

which is the starting place, and the whole revolution brings it to A again, the six additional holes bringing it round to arm B, arm B having been already adjusted and locked in position. Now put the spring pin into this hole next to arm B, and turn the sector round until the arm A is again up against the spring pin, after which the operation is repeated for every division required.

Compound Index

The use of a compound index makes it possible to obtain divisions that would be impossible with an index table used in the ordinary way, and it involves the use of two circles of holes instead of one. In one circle, the index crank and spring pin is used in the ordinary way; in the other circle the stop pin is used as an indica-

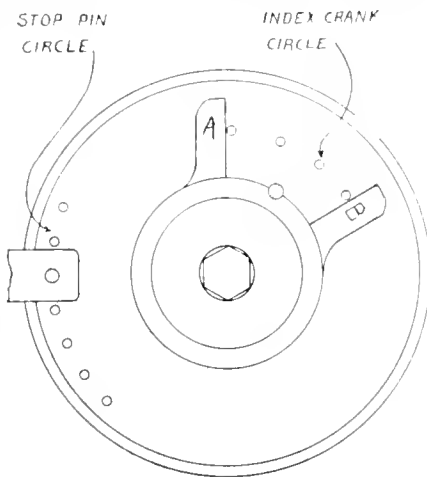

FIG. 83.

tor. In making the movements, after the necessary calculations have been made, first the index crank is turned round and put in position at the required number of holes, then the stop pin is loosed and the whole index plate turned back or forward a certain number of holes in this circle. The movement resulting from these two moves will be either their sum or difference. (See Fig. 83.)

For illustration, suppose circle No. 1 has been chosen with 40 holes, to be spaced off by the index crank, and circle No. 2 contains 39 holes, to be spaced off by the stop pin, if we move the index crank one hole we have obtained 1/40th of a turn. Now if we move the plate forward one hole on the 39 circle, using the stop pin as an indicator, the net result is that we have moved the index plate forward $1/40 + 1/39$, or $79/1560$ of a turn, a result that would be manifestly impossible to obtain by simple indexing.

Compound Index Calculations

Rule for calculating the moves in compound indexing:

- 1—Put down the number of divisions required and find all the factors the number contains.
- 2—Select for trial two circles of holes, subtract the number of holes in one circle from the number in the other, and find all of the factors for the number which represents the difference between the two circles.
- Draw a horizontal line under these factors.

3—Find factors of the number of turns of the crank for one turn of the index head spindle and put them down under the horizontal line.

4—Factor the number of holes in the two chosen circles.

5—Cancel all equal figures above and below the line.

If all the figures above the line cancel out, the two trial circles can be used.

6—Multiply all the remaining figures below the line. This will give the number of holes to be used in each circle.

If all the figures above the line do not cancel out, other circles must be chosen for trial until suitable circles are found, or the combinations exhausted.

Applying the Rules

Example: Find circles and number of holes to be used to divide a job into 77 equal divisions by compound indexing; following the rules given above.

- 1—Number of divisions, 77, factors = 7×11 .
- 2—Chosen circles, 49—44, difference = $5 \cdot 1$.
- 3—Number of turns of crank, 40, factors = $2 \times 2 \times 2 \times 5$.
- 4—Factor chosen circles, $49 = 7 \times 7$
 $44 = 2 \times 2 \times 11$

5—Cancel all equal figures above and below the line.

6—Multiply all remaining figures below the line to find number of holes to be used — $2 \times 2 \times 2 \times 7 \cdot 2 \times 2 = 224$ holes.

224 holes in 44 circle—224 holes in 49 circle or

224	44	49
-----	----	----

224	44	49
44		
224		
49		

— 5 turns plus 4 holes.

— 4 turns plus 28 holes.

Deducting an equal number of full turns from each side will not alter the



FIG. 84.

relative value, so that we have, after deducting 4 turns from each side, $1 = \frac{28}{49}$

Now if we had done this job by simple indexing—that is, assuming it was possible—our fraction would have been $\frac{28}{77}$

so that if our compound index calculations are correct

4	28	40
44	49	77
4	48	48
28	28	40
1	—	—
44	44	44
44	49	77
	12	4
	84	44
By cancelling we get	—	—
40	11	7
77	77	77

— Ans.

It is sometimes necessary to do a job that cannot be calculated absolutely by the index plates available. Such a case came under the writer's notice recently. A milling machine operator had a job calling for 81 divisions, so he cut 27 first (see heavy lines on Fig. 84), and then very carefully sub-divided, one division into 3 by direct measurement. Then he set his cutter to fit the measured division and went round again another 27 divisions, and repeated the operation the third time to complete the job.



FOUNDRYMEN'S CONVENTION AND EXHIBITION

WITH the total number of applications for space in the Mechanics' Building already in excess of the number of exhibitors at Atlantic City two years ago, and with the approximate floor area reserved considerably in excess of that occupied during that show, the success of the exhibition of foundry equipment, machine tools and accessories, to be held at Boston, September 25 to 28, is assured. Indications now point to the greatest show of this kind ever held, and it is probable that in number of exhibitors all records will be broken.

Manufacturers who have reserved space now are making preparations to ship their exhibits at an early date to avoid delays in delivery due to the congested condition of the railroads. As soon as delivered, all equipment will be stored in Mechanics' Building until the date of the opening of the show. An added feature of the exhibit will be the display of motor trucks. Manufacturers of these vehicles have been extended an invitation by the exhibition committee of the American Foundrymen's Association to display their products and a representative number of types undoubtedly will be displayed.

Technical Programme

That the technical features of this great gathering of foundrymen have not been neglected is reflected by the 44 papers that already have been secured, and to these must be added a large number of committee reports. The Boston meeting will be opened on Tuesday morning, September 25, in place of Monday afternoon, as at Cleveland last year, and morning sessions only will be held, closing Friday, September 28. Simultaneous sessions for the consideration of papers on gray iron, steel and malleable iron will be necessary to dispose of the lengthy programme that has been prepared. Registration will open at the Copley-Plaza on Monday morning, but on Tuesday the headquarters will be trans-

ferred to Mechanics' Building, where they will be continued throughout the remainder of the week.

General Topics

Symposium on "Military Stores":

"Making Shells in Permanent Molds," by Edgar A. Custer, Philadelphia.

Paper on Military Stores, by Dr. F. C. Langenberg, Watertown Arsenal, Watertown, Mass.

"Small Steel Castings for Ordnance Purposes," by Major C. M. Wesson, Watertown Arsenal, Watertown, Mass.

Symposium on "Refractories":

"Refractory Materials Employed in the Metallurgical Industries," by H. C. Arnold, University of Illinois, Urbana, Ill.

"Cupola Refractories," by G. E. Jones, Whiting Foundry Equipment Co., Harvey, Ill.

"Factors Contributing to the Economical Use of Grinding Wheels in the Foundry," by Wallace T. Montague, Norton Co., Worcester, Mass.

"Results of Tests in Blending and Mixing Sand by Means of Mullers," by R. F. Harrington, Hunt-Spiller Mfg. Corp., Boston.

"Experiences with Sand Mullers from their Conception to their Final Application to the Foundry Industry," by P. L. Simpson, National Engineering Co., Chicago.

"Fillet-Sizes," by Frank R. Jones, University of Kansas, Lawrence, Kans.

"Sand Blasting," by H. L. Wadsworth, Sand Mixing Machine Co., Cleveland.

"Efficiency in the Foundry," by Jas. A. Fitzgerald, Reno, Pa.

"The Metals of Technology," by John Ritchie, Jr., Mass. Institute of Technology, Boston.

"Welfare Work in Southern Foundries," by J. F. Kent, American Cast Iron Pipe Co., Birmingham.

"Co-operative Shop Training," by W. B. Hunter, Industrial Department, Fitchburg High School, Fitchburg, Mass.

"Scientific Selection of Men," by Wm. Judson Kibby, Cleveland.

"Co-operation," by Chicago Foundrymen's Club.

"The Labor Situation as Relating to Co-operation Between the Employer and the Employee," by G. E. MacIlwain, Babson's Statistical Organization, Wellesley, Mass.

"The Relationship of the Engineering Department to the Pattern Shop and Foundry," by F. J. McGrail, Struthers-Wells Co., Warren, Pa.

Gray Iron

"Seasoning Gray Iron Castings," by L. M. Sherwin, Brown & Sharpe Mfg. Co., Providence, R.I.

"The Foundry from the Viewpoint of the Sales Engineer," by H. R. Atwater, Osborn Mfg. Co., Cleveland.

"The Effect of High Sulphur in Agricultural Machinery Castings," by T. Mauland, International Harvester Co., Chicago.

"The Use of the Microscope in the Foundry," by R. J. Anderson, Cleveland Metal Products Co., Cleveland.

"Modern Centrifugal Cupola Blowers," by J. W. Shugg, General Electric Co., Schenectady, N.Y.

"Making Small Cores Under Economical Conditions," by R. E. Kennedy, University of Illinois, Urbana, Ill.

"Effect of Cupola Practice on the Quality of Iron," by G. S. Evans, Lenoir City, Tenn.

"Briquetting Foundry Borings," by A. L. Stillman, General Briquetting Co., New York.

"Effect of the Presence of Iron Oxide in Molding Sand," by W. R. Bean, Naugatuck Malleable Iron Co., Naugatuck, Conn.

"Machine Made Cores," by Lewis G. Blunt, Romeo Foundry Co., Port Huron, Mich.

Malleable Iron

"Waste Heat Boilers as Applied to the Malleable Melting Furnace," by A. W. Pratt, Babcock & Wilcox, New York.

"The Application of Pulverized Coal to the Malleable Melting and Annealing Furnace," by Jos. Harrington, Chicago, Ill.

"Application of Waste Heat Boilers to the Malleable Melting Furnace," by C. D. Townsend, Danville Malleable Iron Co., Danville, Ill.

"Strength of Malleable Iron," by Prof. Enrique Touceda, Albany, N.Y.

"Application of Pulverized Coal to the Malleable Melting Furnace," by W. R. Bean, Naugatuck Malleable Iron Works, Naugatuck, Conn.

"Malleable Iron Annealing; Comparative Carbon Losses, Muffle vs. Pot Oven," by J. B. Deisher, T. H. Symington Co., Rochester, N.Y.

"Troubles Encountered in Machining Malleable Iron; Causes and Remedies," by A. T. Jeffery, Dayton Malleable Iron Co., Dayton, Ohio.

Steel

"Molding and Casting Large Slag Pots," by C. J. McMahon, Illinois Steel Co., Chicago.

"Recent Progress in the Application of the Electric Furnace to the Melting Problem," by C. H. Booth, Snyder Electric Furnace Co., Chicago.

"Discussion of Electric Furnace from Central Station Standpoint, with discussion of Power Rates and Measuring Power on a Maximum Demand Basis," by E. L. Crosby, Detroit Edison Co., Detroit.

"Data on Treatment of Cast Iron in the Electric Furnace," by Jos. L. Dixon, John A. Crowley Co., Detroit.

"Description of a Small Open-hearth Furnace," by David McLain, Milwaukee, Wis.

"Welding," by M. Stuart Plumley, Davis-Bourneville Co., Boston.

"The Use of Vanadium in Steel Castings," by J. Lloyd Uhler, Union Steel Castings Co., Pittsburgh.

"Report of Committee on Steel Foundry Standards," by W. A. Janssen, chairman, Bettendorf Co., Davenport, Iowa.

"Comparison of Electric Furnace and Steel Converter for the Manufacture of Small Steel Castings," by C. R. Messinger, Sivyer Steel Casting Co., Milwaukee, Wis.

"A New System of Burning Crude Oil," by W. A. Janssen, Bettendorf Co., Davenport, Iowa.

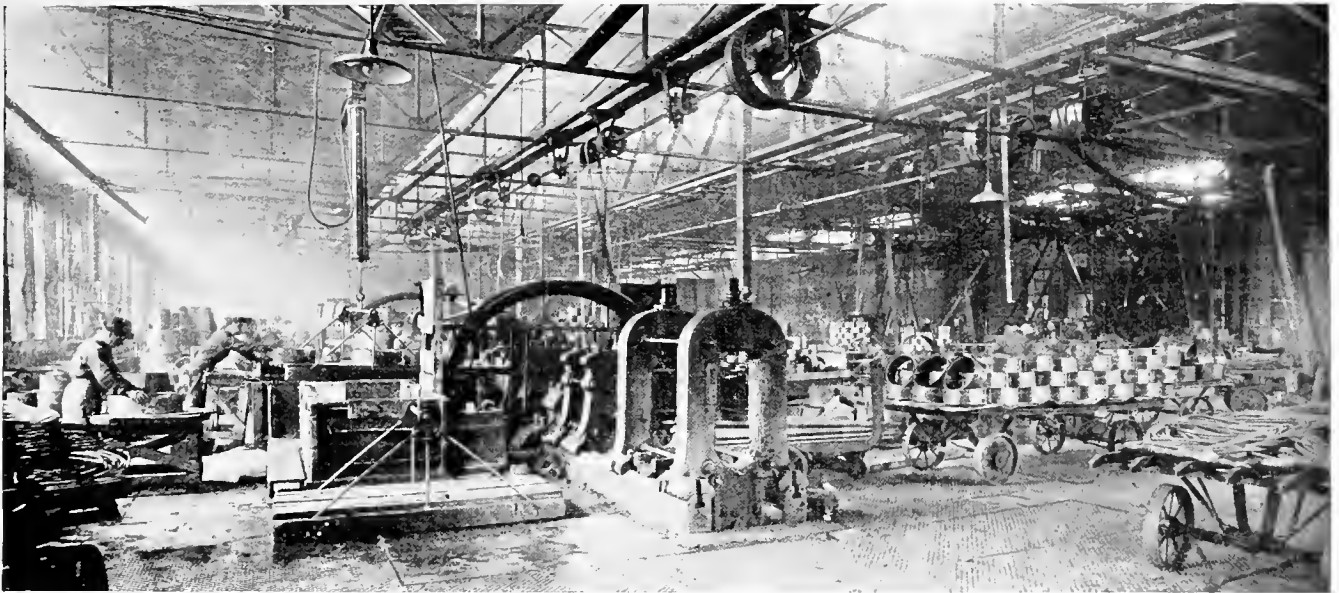

ROLLING BRASS SHEETS IN A LARGE CANADIAN METAL WORKING PLANT.

Present Day Production of Metals and Minerals in Canada

By J. M. Wilson*

Despite restrictions of output and reductions in operating efficiency the mining industry of Canada has maintained its position well and in some respects where subject to war stimulation, its efforts have been greatly extended and widened. Metallic magnesium, metallic arsenic, ferro-molybdenum, Cobalt alloys, nickel refineries, all testify to the capacity and ability of the mining industry, presaging a future continuance of its present prosperity.

ABOUT a century and a half before Confederation, early French settlers carried on the mining and smelting of iron ore near Three Rivers in Quebec Province under a grant from Louis XIV. In 1915, there were 22 blast furnaces located in 12 separate plants, which in 1916 produced 1,169,257 short tons of pig iron valued at \$16,750,903 the previous highest production having been in 1913, when 1,128,967 short tons were produced.

Despite its antiquity, and its present important dimensions, the growth of the iron and coal industry in Canada has been of comparatively recent date, the third quarter of the last century having seen numerous vicissitudes and successes in various parts of the country. The present day, however, sees the sister industries supporting the country in time of stress and, with numerous dependent activities, achieving an undreamed of development when compared with the proportions existing at Confederation.

Relative Importance

While the present state of activity will be subject to modification when normal conditions return, the mineral and manufacturing resources of the Dominion have greatly altered their relative positions in the country's trade, and in so doing have betrayed a welcome wealth of material which under other circumstances might easily have remained more or less dormant. A glance at the accom-

panying table shows that manufactures have advanced from fifth place to second place, increasing thirty-eight fold, and mineral produce now occupies fourth place instead of sixth, its increase being twenty-nine fold.

VALUE OF CANADIAN EXPORTS.

	1868-70	1915	Ratio
	\$	\$	
Agricul. produce, millions..	123 $\frac{1}{4}$	134 $\frac{3}{4}$	10.5
Animals and their produce.	9 $\frac{1}{4}$	74 $\frac{1}{4}$	8
Fisheries produce	3 $\frac{1}{2}$	19 $\frac{1}{2}$	5.5
Forest products	204 $\frac{1}{4}$	421 $\frac{1}{2}$	1.9
Manufactured products	2 $\frac{1}{4}$	85 $\frac{1}{2}$	38
Mineral products	1 $\frac{3}{4}$	51 $\frac{3}{4}$	29

The extent to which nearly all manufacturing industries are dependent on iron and coal for their existence lends additional interest to the value of manufactured exports, a value which reflects itself back through machines, chemicals, equipment, and power, to the earthly twins, iron and coal.

While not of such great value, the mineral produce is of particular interest, in that rare and commonly occurring materials are here found in more or less abundance, the variety being profuse indeed, and, with the exception of radium, vanadium, uranium, and platinum, including nearly every other mineral and metal found in any other country. Many of the products mined to-day were comparatively unknown to the world of science in 1867, yet at this moment are produced in large quantities, to play their part as essential substances in the

world war, and later as mainstays of the Dominion's commercial life—nickel, copper, silver, gold, asbestos, and aluminum to mention a few only.

Coal and Iron Inseparable

Apart from their individual values to civilization, the interdependence of iron and coal is such that a review of either without the other would be incomplete, yet it is a peculiar feature that the greater part of the raw material used is imported; for instance, in 1914, 94 per cent. of ore, 50 per cent. of coke and 56 per cent. of limestone necessary for pig iron production was imported. In the early days, however, both ore and fuel were produced at or near the scene of operations, largely because of the undeveloped state of transportation, and for this reason we find the province of Nova Scotia early occupying the premier place amongst Canadian provinces as a producer of iron and coal.

As far back as the year 1601, the discovery of iron ore in Nova Scotia by one of the French governors of Acadia is recorded, but no real development took place until during the first half of the nineteenth century, during which several discoveries of ore were made until in 1880, iron ores were known to occur in fifteen of the eighteen counties of the province. The earliest record of coal in Nova Scotia is said to be in 1672, but apart from sundry efforts, no organized development took place until the year 1825, when a company known as the

*Associate Editor, Toronto.

General Mining Association, Ltd., of London, Eng., acquired all known and unknown minerals, except those previously granted. Circumstances subsequently enabled the company to secure control of all mines and minerals and insured the continuance of coal mining at the well known seams of Stellarton, on the mainland, and Sydney Mines, in Cape Breton.

Nova Scotia Districts

Mineralogical features and transportation facilities early combined to divide the Province of Nova Scotia into three districts known as Pictou, Cumberland, and Cape Breton, and up till the decade preceding Confederation, more or less intermittent efforts were made with varying success. In 1825 the Annapolis Iron & Mining Co. erected a 35 ft. stack at Clementsport, but after two years' operation closed down due to political influences, being stopped till 1860. Again in 1862, it shut down for ten years, resuming operations in 1872, when 600 tons of ore from a local mine were smelted, the resulting yield of 163 tons of pig iron going to Boston. White birch charcoal made locally, was the fuel, and fluxes were imported from St. John, N.B. This last effort only extended six weeks.

In 1828 an abortive effort was made by the General Mining Association to manufacture pig iron in Pictou county, but the first attempt which accomplished really tangible results over a term of years was that which resulted in the formation in 1874 of the Steel Company of Canada, with a capital of £500,000. This was one of the high water marks of a business which had its inception in a Catalan forge in 1850, followed by a smelting furnace with water power and charcoal fuel, producing seven tons of pig iron per day. The year 1860 saw a rolling mill added to the plant on the west branch of Great Village River; in 1862, a puddling furnace was added, the bars from which were shipped to Sheffield, and in 1867 a wheel foundry was installed. A subsequent reorganization, in 1887, due to market conditions, saw a million dollar company, the Londonderry Iron and Mining Co., to take control, but the depression of the early "nineties" was the beginning of the end, and only a pipe foundry remains of this extended but fruitless effort.

Concerns of To-day

The two concerns which now represent the iron and coal industry in Nova Scotia are the Nova Scotia Steel & Coal Co., and the Dominion Iron & Steel Co., the former operating plants at Sydney Mines and New Glasgow, and the latter at Sydney. The success of both concerns is largely due to one fact, viz., the availability of high grade ore from the Wabana mine in Newfoundland, but their histories vary much. In 1872, the town of New Glasgow saw the start of the Hope Iron Works near the scene of an unsuccessful attempt by the General Mining Association to smelt pig iron in 1828. By 1885 the business had developed to a point where the Nova Scotia Steel Co. was formed by the principal shareholders, with \$160,000 capital and

a 15-ton acid line open hearth furnace installed along with a 26 in. cogging mill and a 16 in. merchant bar mill. Here the first steel ingots in Canada were produced on a commercial basis, although basic open-hearth practice was adopted five years later, and the Duplex process more recently.

Up to 1889 imported pig iron had been used, but the formation of the New Glasgow Iron, Coal and Railway Co., in 1899 gave access to ore properties which were successfully utilized. In 1894, the Wabana ore fields of Bell Island, Newfoundland, were acquired, and since then the record has been one of continued progress, the present name of the company being assumed in 1900 after purchasing the coal and other properties of the General Mining Association in Cape Breton. Thus one of the most successful of the pioneer bodies was finally taken up by a later and much vaster organization, forming an interesting link with early times and imparting that touch of struggle and failure combined with ultimate success, which adds so indefinitely to the prestige of old established yet modern concerns.

The production of coal from Sydney mines is an important feature, the annual production rising from 250,000 tons in 1900 to 840,000 tons in 1912, one third of this being used in iron and steel manufacture.

From Coal to Steel

The earliest development in this field however, was by the Dominion Coal Co., which in 1893 began active development of the most important coal areas here. It was due to a peculiar combination of circumstances that it was compelled to enter the iron and steel industry, the Dominion Iron and Steel, with a capital of \$30,000,000 being formed in 1899.

The original plant was laid down for the production of blooms, billets and slabs, but was subsequently extended to produce steel in more finished forms. The Co. secured by purchase a portion of the Wabana ore deposits, this material when used with Sydney coal yielding satisfactory results.

Subsidiary enterprises utilize the by-products, over 5,000,000 gallons of tar from the six hundred odd coke ovens being handled, together with cement and fertilizer products from slag. From a production of 950,000 tons of coal in 1893, the output has risen to 4,500,000 in 1912.

Quebec Efforts

In Quebec province the blast furnace industry is almost extinct although intermittent efforts were made dating from the year 1737 mentioned at the beginning of this article. In 1867, Moise was the scene of an attempt to smelt iron on a commercial scale, likewise St. Urhan in 1873 and Hull in 1872 and 1887, all of which were unsuccessful. At Radnor and Drummondville, however, furnaces were operated continuously from 1887 to 1912 on local ore, with locally-made charcoal as fuel, an average output of 8,000 tons per annum being maintained. The present industry

consists of steel production in small open-hearth furnaces and electric furnaces, also the manufacture of special steels the tonnage of which is relatively small.

Ontario a Success

Operations in the Ontario iron and steel industry are unique in the fact that all fuel used together with the greater part of the ore used is imported. Geographical features have divided the plants into two groups the Ontario, and the Lake Superior. Numerous deposits of ore have been found in Eastern Ontario and many of these in Mayo township are shippers.

The early efforts to establish the iron industry date from 1800 when an attempt was made in Leeds county. Normandale was also the scene of a failure a few years later which, however, was more or less redeemed between the years 1832 and 1847 during which time it was successfully operated on bog ores of the vicinity with charcoal fuel. Other efforts were the Marmora furnace 1820-1875, Madoc, Houghton and Burnt River being also the scenes of ultimately abandoned efforts.

In 1892 the province of Ontario was without a single blast furnace, but from 1894 when smelting was started in Hamilton, followed later by the Lake Superior activities, the growth of the industry has been steady. The Ontario district now contains seven blast furnaces, the Steel Company of Canada, in 1913 producing 180,000 tons of pig iron, 157,000 tons of steel ingots, and 192,000 tons of finished merchant bar.

Western Developments

The Lake Superior district contains four blast furnaces, three of which are operated by the Algoma Steel Corporation, Sault Ste. Marie. An idea of the extent of the development at this point will be gathered from its output figures for 1913, pig iron made, 308,000 tons; coke made from American coal, 411,000 tons; steel ingots made, 438,000 tons; steel billets made, 20,000 tons; rails made, 320,000 tons; merchant mill product, 19,000 tons. A considerable amount of native ore is mined in this district, the Helen mine in the Michipicoten range being the largest producer in Canada, with 1,000 tons per day, other shippers are the Helen and Magpie mines, northwest of Sault Ste. Marie, while the Moose Mountain range contains an important deposit of magnetite.

The amount of iron ore mined in Canada in 1913 is not insignificant despite the troubles of pioneer efforts. In that year, 307,000 tons were produced but since then, New Brunswick and Nova Scotia have ceased. Ontario produced 195,000 tons of that amount. Helen and Magpie mines shipping 22,000 tons and Moose Mountain 3,300 tons. In 1914, 244,000 tons were produced in Ontario of which 184,000 tons were shipped to Canadian furnaces and 60,000 tons to the United States.

Mineral Developments

Canada was a gold producer of some

importance at the time of Confederation, the output for the five preceding years being 882,947 ozs., valued at \$18,252,143. British Columbia produced more than seven-eighths of this amount, Nova Scotia supplying the balance. Quebec became a producer in 1877, Yukon in 1885, Alberta in 1886 and Ontario in 1891. In these the Yukon has the record for any one year, 1,077,553 oz. in 1900, valued at \$22,275,000. By 1914, Ontario had secured premier annual place with 268,305 oz. valued at \$5,546,356.

Ontario has a well established lead in silver since 1906, till now she is seven times as productive as British Columbia the figures in 1914 being 24,215,926 oz. and 3,212,111 oz. respectively. in copper, the positions are reversed, British Columbia producing 41,221,628 lb. against Ontario's 28,948,211 lb.

The history of nickel has been recapitulated so frequently of late that further emphasis on its value as a national asset seems impossible in these columns.

Unique Source

Talc, graphite, gypsum, feldspar, mica, corundum, molybdenite, asbestos, and manganite are some of the minerals now produced commercially throughout the Dominion. The world's chief source of asbestos is in Quebec, and with the exception of Ceylon, Canada is the only source of supply of amber mica, the United States securing its supply of this very necessary material for electrical work almost wholly from the Dominion.

Adding to these the existance of petroleum and natural gas on a considerable scale in certain localities, the variety of our natural resources becomes more evident, and when modern developments in water power utilization are taken in consideration, the whole industrial complexion assumes a wonderful aspect in comparison with fifty years ago, a surpassing rosetateness dimmed only by the world cloud of struoele but ever holding forth promise of future brightness and greatness which in other fifty years may well outshine the present, even as the present outshines the past.

FIRE LOSSES LAST MONTH

LOSSES by fire in the United States and Canada last month reached the stupendous total of \$24,968,000 just \$9,000,000 more than the corresponding month of last year.

In these figures are included the values of many expensive Canadian factories and industrial concerns. The rapid growth of the monthly fire loss is causing grave concern. In these days when the country is straining every effort to reach a maximum production, the loss of a single factory is felt, and it is urged that a campaign for great fire prevention be immediately launched.

Losses So Far

The losses in the United States and Canada, according to The New York Journal of Commerce, for the first five

months of 1917 reach the unusually large aggregate of \$129,108,455, as compared with 113,528,920 for the same months in 1916. The following table gives a comparison of the losses for May of this year with those of the two preceeding years, together with the losses by months for the balance of 1916 and 1915:

	1915	1916	1917
Jan.	\$20,060,600	\$ 21,423,350	\$ 36,131,770
Feb.	13,081,250	24,770,770	29,587,669
March	18,786,400	38,880,250	17,523,000
April	18,180,350	12,841,050	18,597,225
May	14,388,450	15,973,500	24,968,800
Total 5 mo.	\$81,497,050	\$113,528,920	\$129,108,455
June	\$ 10,893,950	12,247,500
July	9,005,896	23,013,800
Aug.	10,067,109	19,745,099
Sept.	14,823,590	12,244,625
Oct.	11,165,850	17,701,375
Nov.	21,201,850	19,898,450
Dec.	20,877,100	22,063,325
Ttl. for yr.	\$182,836,200	\$231,442,995

Big Fires in May

There were some 261 fires during May each of which caused an estimated property damage of \$10,000 or over. This compares with 244 such fires in April, 270 in March, 381 in February and 303 in January, making a total of 1,459 fires since the first of the year, which caused a loss of \$10,000 or over. The May fires classified according to their destructiveness, show the following results:

Estimated Loss—	No. of Fires
\$ 10 000 to \$ 20 000	71
20 000 to 30 000	53
30 000 to 50 000	41
50 000 to 75 000	31
75 000 to 100 000	19
100 000 to 200 000	25
200,000 and over	20
Total	261

Of the twenty large fires during May which each caused a loss of \$200,000 or over, the following are worthy of special notice:

Location—Description—	Amount.
Columbus, Ohio, department store	\$ 300,000
Pocatello, Idaho, garage and 200 autos	340,000
Toronto, Ont., ammunition factory	350,000
Sioux Falls, S. D., grain warehouse	1,000,000
Macon, Mo., railroad station, etc.	550,000
Lexington, Ky., several business houses	600,000
Atlantic, Ga., dwelling section of city	5,000,000
Fort William, Ont., stove Works	500,000
Bowie, La., lumber yards and dwellings	1,000,000
Greenwich, Conn., dwelling	300,000

Practically all of the important fires in May involved well insured property, and the fire underwriters, who had suffered severely in the first quarter of 1917, are now much worse off.

Ontario Figures

The summary of fire losses in Ontario during the first four months of the year is as follows:

	No. of Fires	Loss	Insurance Loss	Loss not covered by Insur.
Jan.	738	\$ 808,418	\$ 566,589	\$ 241,830
Feb.	1,020	1,369,139	1,105,039	264,109
March	765	1,144,373	886,126	258,247
April	666	1,201,361	998,384	202,977
Total ...	3,249	\$4,523,292	\$3,556,138	\$967,154

While the aggregate amount of the April loss (\$1,201,361) is in excess, it is gratifying that the number of fires in the province in the month of April is less by nearly one hundred than in the preceding month, declares the report of the Ontario Fire Marshal. Unfortunately, the aggregate of the fire loss is due almost entirely to two large fires, both of which are under investigation. In Hastings county, Graham & Company's evaporator at Belleville was burned, involving a loss of about \$185,000. In Norfolk county, the loss is almost exclusively caused by the fire in the premises of the Dominion Cannery at Simcoe. It has not yet been ascertained what the exact amount of the loss by this fire is, and we are consequently estimating it at the figures furnished in the official Fire Chief's report, namely, \$23,000 on the building and \$500,000 on the contents. This may be very far astray, but it is the official estimate and when the loss is determined, it will be adjusted in the subsequent month's return.



CAR SHORTAGE IS SERIOUS

Representatives of the various Boards of Trade and the railway companies are to meet in Ottawa on July 3rd, to outline a plan for revising the existing car demurrage rules. If an agreement can be reached the Railway Commission will be asked to ratify the new regulations immediately. It is felt that if the present rules are not changed car shortage will become more acute month by month.

"The public should have a clear realization of what is aimed at in the revision of these demurrage rules," said J. E. Dalrymple, vice-president of the Grand Trunk, recently.

"The situation is unprecedented. In every territory on the continent there is a demand for cars that cannot be fully met. It is useless to look to the car builders for relief. They have more work now than they can handle. If the situation is to be improved, or at least prevented from becoming more serious, there must be the greatest possible co-operation between the shippers, the consignees and the railways. Every car available must be kept moving and every car must be loaded to its capacity. That is without doubt the only way out of the present difficulties. Any measures that may be adopted to prevent the undue holding of cars for loading and unloading will, therefore, be of national advantage. Rules that were probably equitable under normal conditions are to-day hampering the efficiency of transportation."

EDITORIAL CORRESPONDENCE

Embracing the Further Discussion of Previously Published Articles, Inquiries for General Information, Observations and Suggestions—Your Co-operation is Invited

FUNDAMENTALS OF EFFICIENCY

By J. E. C.

AN efficiency system, as generally understood in the machine industry, means a system or plan, designated by such terms as scientific management, industrial management, etc., installed for the purpose of increasing production. Under these captions are included, motion-study, time-waste, and other expressions too well known to need mentioning.

Efficiency in its broadest sense is something that has to be developed, and relates to several conditions and things, each separate in themselves, each subject to close scrutiny and observation—finding out where their particular waste and inconvenience lie, and improving these according to their needs. By this particular method do we arrive at the point where efficiency is to begin, or to state it more clearly, where a saving is to be had, where production can be increased, and where that which is now a wasteful method, is overcome.

Expense Origination

When a factory whistle blows, or the power starts up, it may be said the factory expense begins, at least its heaviest item, the wage expense. If the workman is precisely there on the moment to start his machine, and continues steadily at his work until the power shuts down again, it may be said there is no loss or time-waste taking place so far as his labor account is concerned.

While it is quite impossible for anyone to work without a certain amount of relaxation, nevertheless this describes the point exactly, whether there is or is not a loss. In other words, it may be said that efficiency means a gain, inefficiency means a loss.

It is through the overcoming of these losses that gains or savings are made. Getting as much out of the workman, compatible with what is reasonable and humane, from the time he enters the factory till he leaves it, is what counts in profit or loss of any machine concern. Whatever he does, whatever he handles, whatever is convenient or inconvenient to him, in the way of tools and accessories, are all a part of this given study. It makes little difference how much has been done, or is being done, in the way of improving methods, or, more properly speaking, what follow-up system is used in eliminating waste, reducing time in operations, the principal part is the state of activity in which workmen perform their labors, the amount and kind of "exertiveness" they display while doing their several tasks. Now a workman can pick up a wrench quickly or slowly. He may move as one always ready on the minute, or be slovenly disposed in what he is doing.

Workmen's Dispositions

No two workmen are alike in their movements in any factory. And because of this it can be pointed out how far short production fails in its accomplishment. And yet this is the precise point, that needs mostly to be looked into. There is a certain rhythm and steadiness that can be followed and practised in any occupation which will result in a considerable saving in time. It must not be construed that this is what is called grinding down or squeezing the utmost out of workmen—far from this. It means simply developing in him a taste for healthy energetic activity. It is working out a firmness, a preciseness in every effort he makes, even in every step he takes, moving swiftly and surely, or to state its fullest meaning, being always sure-footed, exact, prompt, free from any hesitation, always on the alert.

These are the fundamentals of efficiency work. They mean something more even than being dexterous or being possessed of an aptitude for doing certain classes of work.

The word "exertiveness," mentioned above, specifically states the effective sense and meaning of cultivating increasing efficiency along any line of manufacturing.

It spells power, a combination of physical and mental force that acts energetically in whatever employment one is engaged in. One may ask, can a workman be all these things, and constantly so, throughout the course of one day even? Would this not be a harmful proceeding? Would it not result in a physical breakdown? To this it may be answered, that no one ever did overwork, or felt any harmful effects therefrom. As much, even if not more, harm has come from being shiftless, lazy, and lacking interest in one's work, because this leads to or is being inefficient.

Any one of these things stagnates the human frame. A physical break-down is seldom if ever the result of overwork. History records no instance of any great man—and most every great man has been a worker, being carried off by overwork. On the contrary, the greatest loads have been carried, the most tremendous tasks have been accomplished, leaving the worker still ready and alert to tackle something still greater.

An Incentive Necessary

It is possible to train workmen to be exertive. Behind this lies the main principle which attaches to itself the real importance for effective efficiency. In doing this, of course, one must look at the main purpose. What is the main purpose? From the workmen's point of view increased activity must mean something more besides increased activity. It must mean increased compensation. In-

creased compensation means awakened interest. And it is interest, interest alone, that awakens the blood, sets moving faster and making richer the red corpuscles that circulate in the veins and arteries of the human body.

Interest, then, is the secret of efficiency, exertiveness follows as a matter of course. On the other hand, the principal thing is to keep interest alive. How to do this need not be gone into here. If it is necessary to give workmen intervals of fifteen minutes' rest twice a day it should be done. If it is necessary to shorten their hours of labor it should be done. Where interest lags or becomes deadened, efficiency follows suit; it begins to drag; the wheels of industry become clogged in their bearings. Beyond and above all is interest.

A case in point may be cited in regard to ammunition workers. The complaint has been called forth that the production in shells is nowhere near the amount possible. Why? Because they have already made so many that they have become deadened to the work. And yet, what are they making shells for? Is it not for themselves? Are they not working for the same ends as those who are firing them? This fact has been emphasized, been bought home to them time and again, yet has it resulted in any noticeable speeding up on their part? Very little. Their failure may be laid to the fact that the thing most lacking is exertiveness. They have not been trained to exert themselves; trained to set their pace so as to be producing to capacity every moment they are engaged. In their particular case they should be "doing their bit" and a little bit more, for in this they are as much heroes as those engaged with the enemy—their work is heroic action. Each represents so much man-power per unit in the present world's great conflict.

Key to Efficiency

To sum up, exertiveness is the key to efficiency, the mainspring to productive activity. The direct opposite of being listless. It is the direct line in which good and efficient workers are made. The creation of this man-power is applicable to industrial work, and will develop a class of workmen vastly superior to those who at present move in a monotonous routine or are left to act on their own initiative. To enthrone workmen by some incentive has always been the outstanding mark towards which employers must incessantly strive. But aside from personal profit and financial gain the constant exercise of exertiveness on the part of a worker will greatly tend to increase his efficiency; smooth away his rough edges; from being slow gaited, he will become lively-stepping; will concentrate his mind on what he is doing, on the mo-

tions he makes; and by so doing will increase his worth and value, both to himself and his employer.



BY-PRODUCT COKING

By T. J.

AMONG many branches of development in modern scientific industry there is probably none of which less is known to the general public than that of by-product coking—that is to say, of the manufacture of coke on a large scale for use in the blast furnace and the foundry, and of the contingent recovery of valuable by-products from the coal used. Formerly all coke for use in the metallurgical industries was made in "beehive" ovens—a considerable portion of it being yet made by this primitive process, in which a considerable portion of the carbon, as well as the volatile elements given off under the influence of heat are consumed to keep up the temperature of the oven. The only product of this system, therefore, is a remainder in the form of coke, amounting usually to about 60 per cent. by weight of the coal put into the oven.

About thirty years ago the by-product oven was introduced, and more recently it has made such progress concurrently with improved methods of recovering and treating the by-products that at the present time the larger proportion of the coke production of Britain is made under by-product recovery conditions. The essential difference between the two systems is that while the older one is a burning process (with necessary limitations as to the amount of air admitted to the oven), the newer one is purely a distillation process involving external heating and the total absence of air; and whereas the product of the one consists of coke only, that of the other, besides a larger quantity of coke from a given weight of coal, includes also, in some cases, a large volume of surplus gas, in all cases valuable residuals in the form of coal tar and ammonia, or ammonia compounds, and in many cases benzol which is the principal "intermediate" of some of our most powerful high explosives, and of many varieties of coal tar dyes.

Among other things, little known to the public, is the large part which is being played by the by-product coking industry both in helping the Allied nations to win the war and in keeping going many of our most important industries under war conditions.

By-Product Ovens Surpass Gas Works

The popular idea is that the principal source of ammonia and toluol, for example is the gas works of the country. In point of fact, the by-product of coke ovens, and certain closely allied processes yield more both of coal tar and ammonia than all the gas works of the country combined, and much more of benzol and toluol, which they are able to recover from their gas more systematically and thoroughly than the gas works can from theirs. Altogether, there are now about 120 by-product coking plants in Great

Britain, comprising about 8,000 ovens, each carbonizing a coal charge of from eight to ten tons in from 30 to 36 hours, or approximately five charges per week. As the operation of the plants is continuous the potential yield of metallurgical coke per oven per year, allowing liberally for all contingencies, and for occasional repairs, may be taken at from 1,200 to 1,500 tons, so that the aggregate output may be put at approximately 10,000,000 tons.

In some cases the ovens have regenerators; in some they have not. In the latter case the greater part of the gas given off in the process of carbonization is used for heating the oven flues—in the former only about half is required for this purpose, so that there is a large volume of gas available for consumption under steam boilers (thus again saving coal), for use in gas engines, or for sale. In several cases the surplus gas is cheaply sold to power companies, and raises steam for the generation of electricity; in others it is transmitted to iron and steel works for heating purposes, in others, again, it is sold to the statutory gas authority of the locality for the town lighting.

The town of Middlesbrough is now wholly lit by gas from the coke ovens of Messrs. Samuelson & Son, Port Clarence Works, and the supply of the City of Leeds is partly derived from the coke ovens at Middleton Colliery some miles away. Generally speaking also, each ton of coal distilled in the by-product oven yields from 7 to 9 gallons of tar, from 24 to 32 lbs. of sulphate of ammonia, and in the majority of cases now, from 1½ to 2½ gallons of benzol, which is sometimes sold to chemical works in crude form, and sometimes fractionated on the spot to commercial benzol, toluol, xylol, and solvent naphtha. Some of the plants have also their own distillery, and some recover naphthalene or ammonium chloride.

No actual figures can be readily given, but it may be affirmed with confidence that the by-products thus recovered on modern coking plants in England, Wales and Scotland, represent an annual value of \$10,000,000 (all of which would have been lost in the "Beehive" oven process). There is also the consideration that to produce the same weight of coke under the old system at least a million tons of coal would have been required, an important consideration at this time, when the supply of coal is unequal to the demand.



THE AEROPLANE AS A MEANS OF COMMERCIAL TRANSPORT

By L. E.

RECENT developments in aeroplanes, both as regards engine power and improved construction, have caused many to wonder whether this generation or the next will see fleets of aeroplanes acting in the capacity of commercial transporters. Will developments which the war has produced in aeronautics, enable the industry to contemplate any other market for its wares than naval and

military? Developments prior to the outbreak of the war clearly showed that the tendency was to concentrate on evolving a satisfactory instrument of war, and in the odd leisure moments left to manufacturers since war broke out, they have doubtless contemplated the use of the aeroplane in new directions, but it is certain they have not had time to go into the matter closely. Perhaps in a few months' time they will have more leisure for this subject—perhaps they may not.

In the case of the immense Russian Sikorsky biplane, there is promise of a machine more especially designed for peace than war and in the institution of an official aerial service for mails in 1913 by the French Minister of Commerce between Paris and Nice, there was another attempt to employ the aeroplane in the utilitarian rather than a military way. Apart from these few efforts made in those days before the war, the fact remains to-day that the aeroplane is not yet an instrument of commerce.

Progress in science is always going on, but at present it has been directed to the ends of war, and until the war comes within measurable signs of finishing the demand will be more and more insistent; nevertheless, it is interesting to enquire why there has not been some attempt made to make the commercial aeroplane possible.

What Limits Progress?

Some investigations were made in the year 1913 and the result was bluntly announced that the aeroplane could never be a commercial vehicle of motion for either passengers or goods, but no enquiry has yet been made as to the actual source of hindrance. No one has yet touched the spot where progress in this direction is retarded. Yet even scientists in Germany are proposing to use airships rather than aeroplanes for their much vaunted service between Germany and the United States. It would be interesting to know why they have decided against the aeroplane. Let us see what we can find out as to the causes of hindrance up to the present.

Until recently the difference between the ideally constructed aeroplane and what was turned out of the shops was very great. The realization of the ideal would be for each one part of the machine to have one, and only one, function to perform. The wings of a flying machine are primarily a means of obtaining lift, but in the majority of machines the rolling of the machine is controlled by warping the wings—a really crude way of relieving the designer's ideas. True, the designer is restricted by what the constructive department can do, and they again are restricted by the materials in hand. All questions of improvement resolve themselves into one of the material, and if all the secrets of existing new materials could be revealed, it would probably be found that there is now a light strong alloy which makes possible the construction of the wings and their entire covering of metal.

Further, there is the question of motive power. The evolution of the light

powered motor, occupying a small space, has been fairly successful, but better ones will be turned out in the future when the experience gained in our army and navy has been collected and distributed. But efficiency is only one side of the question. The total power consumption is even more important. With an improvement in the construction of the body and wings of the machine, a certain lessening of the horse-power required will follow automatically, and this, with the improved efficiency of the engine itself, should perceptibly decrease the running charges—really the greatest bar at present to the use of the aeroplane commercially, for this expense is quite out of proportion to its dividend earning capacity.

Minimum Power Record

According to some investigations into aeroplane records, the lowest power used on an aeroplane was 9 horse-power, with which Mr. A. V. Rowe actually accomplished, in 1907, some flights with his triplane. No one in his senses would dream of repeating the experiment, for it is only at high speeds that there is any approach to safety, so that it is even rare to find a horse-power nowadays under 50, or even 70.

The aeroplane, to be commercially successful, must yield the small cost of the 9 horse-power machine per passenger, or per hundred weight of goods carried. For example, instead of carrying 1½ cwt., or 80 kilos, the 100 horse-power Doute machine on the Paris-Nice mail service would have to have its load increased to 15 cwt., and the Silkorsky biplane would carry about 150 passengers instead of 15 with a horse-power of 400—but at the sacrifice of speed.

Because of the manifest impossibility of considering that point at all, the acceleration of the mails between Paris and Nice has a financial value that cannot be estimated at all for there is no data to go upon. On the other hand, it might be regarded as just to neglect the speed factor, for it is only possible for the aeroplane to travel at high rates of speed with safety; the inability to move slowly may be as much on the debit side of the account as the rapidity of motion on the credit side. Nearly all the machines at present in use are undoubtedly stronger and safer than those used in the early years of the present decade, and presently an entirely new principle of obtaining sustentation may be evolved or some method of further developing and applying the propulsive power. The high costs of running, increased for the moment by the cost of oil, petrol and labor, may limit the aeroplane, for the present, to those uses and duties in which high and speedy flight is required for itself alone, but there is no reason to doubt its use as a commercial means of transport in the not far distant future.

The speed of an aeroplane is, of course, vastly superior to other modes of travel; though its arrivals and departures are liable to be affected by weather conditions, and whilst its motion might be easier for the human body, its special

qualities will be available for many branches of commercial work. In the future we may see regular fleets of airships and aeroplanes in practically daily use, and then we shall wonder why we never used them earlier.



A SPECIFIC INSTANCE OF SPECIFIC GRAVITY

By J. E. McCormack.

WHEN the writer tells anyone that he has seen solid pieces of iron actually floating on liquid—yes, solid pieces of iron actually floating on liquid” — he takes grave risks of having his word doubted, but the story is really true. Not expecting to see such a thing at the time, he poked with a stick to make sure if what he saw was foreign matter, and floating. He then removed one of the pieces to ascertain its nature, and, upon finding it to be iron, put it back into to liquid again to make sure if it did float, and float it certainly did. A little common sense readily explains the phenomenon, but occasionally a fellow may not happen to be thinking of common sense when first looking at exceptionally uncommon occurrences. We are so accustomed to seeing iron sink that we do not expect solid pieces of it to float of their own accord under any circumstances and this fact might lead some one to sometimes quite innocently make the same experiment that procured for the writer the privilege of seeing iron floating.

The paper frictions of a certain machine needed re-filling and for this purpose were sent to a machine shop in another town. When they were returned one of them was too large to allow its shaft to go down into the bearings properly. Its neighboring friction wheel worked below it and therefore the remedy adopted was to re-babbitt the bearings, but with the shaft lined up an inch or more higher than before, the caps of the bearings being shimmered, or packed up accordingly. As this left a large space to be filled a couple of pieces of old sleigh-shoeing were put in the bottom of each box to help fill up the space and thus save babbitt. The scheme happened to work all right. Probably some of the blocking that supported the shaft was resting on these irons instead of the shaft having been supported by independent blocking placed outside of the bearings.

Some year later, when the frictions had become worn down considerably, the writer undertook to re-babbitt those same bearings, putting the shaft down to near its proper place again. The old babbitt was dug out and melted again for re-use (the shaft being one that ran at only a moderate speed), and as the specific gravity of the babbitt was greater than that of iron those long forgotten pieces of old shoeing floated. I wonder by just how much (or little) one or more of them escaped rising up against the shaft while the melted babbitt was flowing around them. If anyone doubt the possibility he is at liberty to drop some spikes or some chunks of iron into a ladle of melted

lead or babbitt some time and see for himself if the iron comes to the top or not.

The moral intended is: If anyone has an exceptionally large space to fill with babbitt, don't attempt to fill part of it with old iron without making sure to block it well away from the shaft itself for keeps, whether above or below, lest he afterwards finds that in places he has an iron to iron contact in his newly poured bearing.

Had it not been for the above experience, he would probably even yet have expected that iron placed in the bottom of a space about to be filled with babbitt would remain there even if depending only on its own weight to hold it down. He would probably not have mentally compared the specific gravity of the two metals.

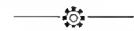

REMOVING BROKEN SET SCREWS

THE quickest removal of a broken set screw ever witnessed by the writer was accomplished by a special tool made from an overgrown three-cornered file. About two-fifths the length of the body of the file had been broken off its smaller end, and the newly broken end on the larger piece ground down to a pyramid shape. Most of the tang was also removed. This tool had been made some time before and for this class of work. The other tools used were, a drill, a lever, and a wrench. The diameter of the drill used was possibly half, but not more than that, of the screw to be removed.

A hole was first drilled in the centre of the broken screw, deep enough to give the special tool a chance to work without its point coming in contact with the bottom of the said hole. This special tool was then placed with its sharp end in the hole and the lever placed inside the frame of the machine and across the tang of the tool, then pressure applied to force the tool into the hole. The tool was then turned backwards with a wrench. At first it acted like a counter-sinking tool, but soon got hold of enough metal to enable it to give the broken screw a turn and the job was soon finished.

On paper the job looks bigger than it really is. A large three-cornered or square can be easily made into one of these tools and if a size strong enough for the work, will last indefinitely. The drill, wrench and lever are invariably on hand in any plant. The depth of the hole required is very much less than where a square tool with parallel edges is used for turning the screw.

These columns have already given us some kinks on which a screw clamp is useful and I believe that in connection with the above scheme a screw clamp could be used sometimes more conveniently than, and instead of, the lever. It would be advisable to select one having a depression in one of its bearing surfaces into which the tang of the tool could bear while in use. With both clamp and lever to hand, the one best adapted to the construction of the affected part and the neighboring members could be used.

Design and Constructional Features of Turbine Pumps *

By A. E. L. Chorlton

There are milestones in the history of the evolution of the centrifugal pump, yet the wide extent of its successful application in turbine form is due to the overcoming of practical difficulties, both mechanical and hydraulic. This work has only been accomplished after prolonged experience, and success has only been reached after tedious and careful study and improvement of small details. In what follows, there is described and traced the development of some of the methods of successfully overcoming the difficulties referred to, while attention is drawn to points in design which are the result of the author's experience, the latter extending back to the infancy of the Turbine Pump Principle in engineering achievement.

THE turbine has become so highly successful as a pumping engine for duties of all description, that no apology is needed for offering a few practical notes on the design and construction of its detailed parts. It will be convenient to consider the subject under the headings of the various component parts of a pump. These are:—

I.—The stator, which consists of (I a) the casing or housing, and (I. b) the guide vanes or appliance for converting velocity energy into pressure energy.

II.—The impeller (considered separately).

III.—The balancing appliance—hydraulic or mechanical.

IV.—The rotor, considered as a whole, and including the spindle with its projecting sleeves, impellers, and in most cases the balancing appliance.

V.—The bed, and other details, bearings, stuffing boxes.

Of these components III., IV., and V., broadly speaking, are the factors governing reliability and resistance to wear, and I. b, and II. are those determining the efficiency.

It is proposed to deal at greater length with III. and IV., for the reason that they have probably been less discussed than the others, also their practical importance is of the greatest moment, but the whole subject cannot be adequately treated within the confines of a paper written during the present time. The chief points only of items I., II. and V. will be briefly reviewed:—

I.—The Casing

The individual impellers of a turbine-pump revolve in chambers or cells containing the outward flow guide-passages and the return conduits for the water; these chambers may be part of a whole in which the outer body is cast in one piece, or, an aggregation of a number of distinct cells without any outside envelope. There are, therefore, two main types:—

1—The Osborne-Reynolds or divided type, and sometimes called the "ring-type."

2—The Sulzer, integral or one-piece type, sometimes called the "cylindrical" type. Recent American practice provides a variation of this type with the housing in halves divided on the horizontal centre line.

The two main types are diagrammatic-

ally illustrated by Fig. 1 (a and b) and Fig. 2 (a and b), with variations in Figs. 3 and 4.

The Osborne-Reynolds pump and its evolution was dealt with by the author in collaboration with Dr. E. Hopkinson, in some detail in a paper read before the Institution of Mechanical Engineers in January, 1912. This type was followed at a later date by the integral one of Sulzer, which had, for a period, a considerable vogue. An examination of the present-day practice of various makers will prove, however, that the ring-type has ultimately proved the preferred one.

turn water-passages back to the centre for conduction to the next impeller; a complete housing is a collection of such cells.

Obviously, in the design, commercial considerations must have a material guidance on theoretical claims. Against the requirements for best theoretical conversion of kinetic energy must be matched the allowable limits of dimensions conformable with commercial possibilities, and, in the interests of efficiency, special attention must be paid to the arrangement and dimensions of the divergent channels or guide-passages. As is

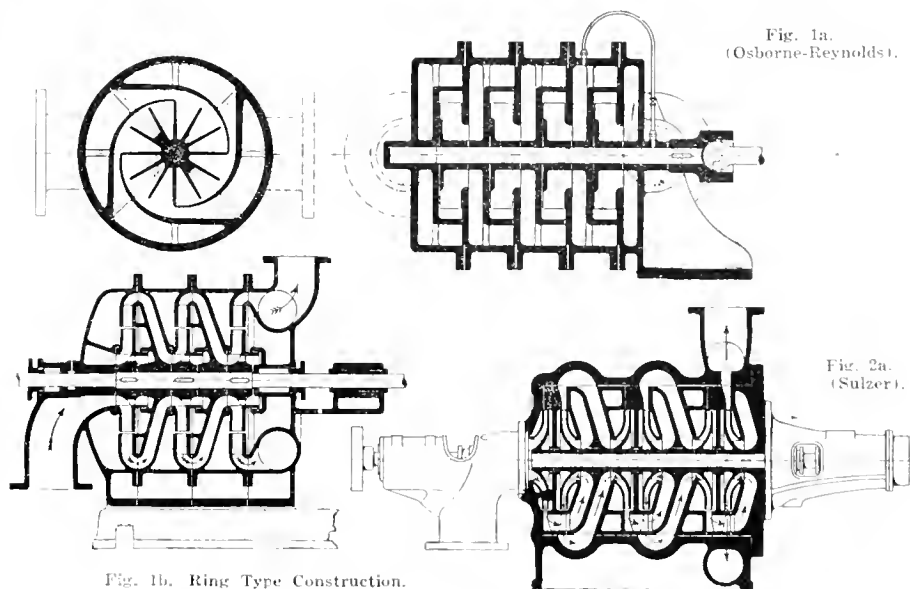

Fig. 1a. (Osborne-Reynolds).

Fig. 2a. (Sulzer).

Fig. 1b. Ring Type Construction.

SECTIONS SHOWING TYPES OF TURBINE PUMP CASINGS.

The Reynolds pump has always used a separate cell for each impeller, and it is therefore correct to say that the ring-type of pump owes its inception to Great Britain. The continental form of the series turbine-pump is due to Sulzer (first pump 1896); in this type a monoblock housing was used for all the chambers or cells, the guide-vanes being inserted from the end.

Before dealing with either type or variations arising out of them, it is advantageous to consider the essential functions of the chamber or housing of a turbine-pump. Primarily, each cell consists of (1) the outward flow guide-passages in which the kinetic energy of discharge from the turbine-impeller is converted into static head, and (2) the re-

well known, the form for guide-passages is represented diagrammatically by Fig. 5, and this passage must be disposed in some form to lie conveniently in the desired casing. The general character will be either a simple outward flow type in one plane, Fig. 6, or a mixed type outward and axial in two planes, see Fig. 7 (a and b) and Fig. 8.

The divergent angle of guide-vane, Fig. 5, for best efficiency was shown by Professor Gibson to be 10° to 11°. In many cases such a small divergent angle leads to a large overall diameter guide-vane in order to give a sufficiently reduced speed of water to permit reversing its radial direction, and the result is a very heavy casing in consequence. For this reason divergent angles of 15° are

*From a paper read before the Institution of Mechanical Engineers.

commonly found in practice. Evidently a more efficient pump will sometimes be heavier and more expensive than one less efficient, and commercial considerations must provide the final deciding factor between efficiency and weight. There is, of

considered to be greater than with the "ring" type, though this is, to a certain extent, a matter of opinion. A great drawback to casings containing separate cells is that, on account of the sliding fit

or bronze, as iron does not preserve a sufficiently good surface for high velocity conditions. Common practice is to provide only three sides of the guide passage in bronze, Fig. 13, but this can only be defended on grounds of cheaper first cost. For best results a bronze-plate should be provided to box-in the passage, the plate being attached to the guide-vane casting or dowelled to the casing. Guide-vanes are sometimes cast completely boxed in, and this method necessitates hand finishing of the passage by file and scraper; open vanes, however, lend themselves better to cleaning out and accurately finishing either by hand or by machining. A good smooth surface is essential for the best results and will always justify the increased cost. The method adopted of securing guide-vanes from rotation and vibration must be a thoroughly sound one or trouble will result.

II.—Impellers

Impellers are either single entrant, or double entrant. The first is almost universally in use for multicellular pumps, and the second almost exclusively for single-chamber pumps; it is only proposed to deal with the single entrant form. Multicellular pumps use the single-eye wheel in three forms:—

- (a)—Unbalanced, unequal side area, one rubbing shoulder, Fig. 14.
- (b)—Unbalanced, equal side areas, two rubbing shoulders, Fig. 15.
- (c)—Balanced—on paper, Figs. 16 and 17.

There are other types, mixed flow, radial and axial, etc., but these are not used to a sufficient extent to be worth including in this paper.

Type (a) may be said to be the one now generally used, that is, the preferable design.

Fig. 2b. Continental pump—cylindrical casing construction.

Fig. 4. Combination of cylindrical and ring features.

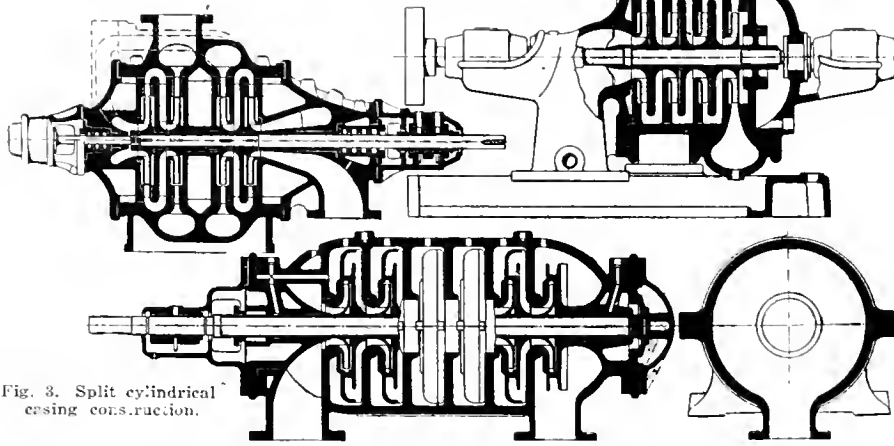

Fig. 3. Split cylindrical casing construction.

SECTIONS SHOWING TYPES OF TURBINE PUMP CASINGS.

course, a school of design which believes in dealing with a proportion of the velocity conversion in the wheel itself, thus leaving less to be dealt with in the guide-passage; the extent, however, to which this method can be used for weight saving is very small, if any. The various assemblies of passages may clearly be grouped into:

- A—Tangential and radial with return radial (see Fig. 6 and Fig. 1, b).
- B—Tangential and spiral (see Fig. 7 (a and b) and Fig. 8).
- C—Combinations (see Figs. 9, 10 and 11).

The Osborne-Reynolds pump (1887 and 1875 type) employed an early form of the B assembly, and has adhered to this type up to the present day, various improvements being embodied from time to time, in some of which the author was concerned. On the Continent of Europe, Messrs. Sulzer introduced in 1896 design A, and the author believes they have made little departure from the type beyond a considerable simplification of their early arrangement of passages. Fig. 2 a Speaking generally, combination designs C are not so efficient as the simpler types A and B, owing probably to the hydraulic loss through changing the radial direction of the water at high speed.

From a works construction point of view, "ring casings," Fig. 1 (a and b), are the most economical, and in practice give high efficiency. In the form similar to that shown in Fig. 12, the author some years ago was able to mould and cast ring-casings without cores, machine moulding being adopted, and the cost per chamber coming out at a very low rate.

For "cylindrical" casings, Fig 2 (a and b), a complete pattern is required for each size and variation in number of chambers. Its accessibility, however, and ease of dismantling is sometimes

between the intermediate pieces and casing, an unknown amount of leakage constantly takes place between the cells. With a "ring" type of pump, leakage is instantly detected and can be remedied. As a commercial proposition the author unhesitatingly favors the divided or "ring" type of casing, and when properly carried out, has met no difficulty with it in practice.

Finish of Guide Passage Surfaces

Before leaving this part of the subject, a word about the finish of guide-passage

Fig. 5. Form of Guide Passage—Throat Only.

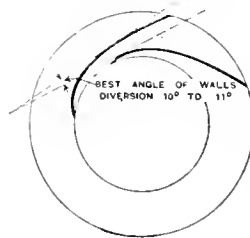
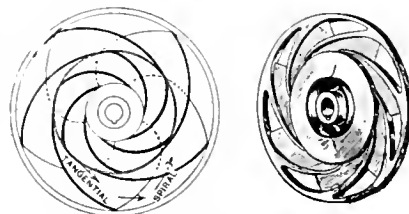
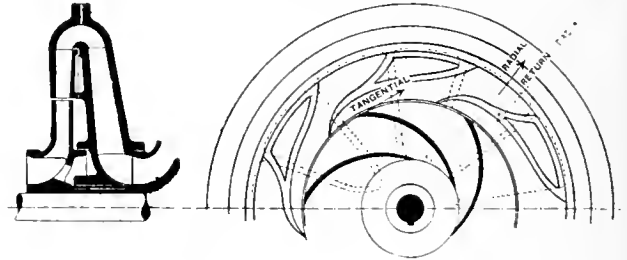

Fig. 6. "Stage" or Cell." Flow Tangential and Radial: Return Radial.



a—Flat. b—Perspective. Fig. 7. Flow Tangential and Spiral.

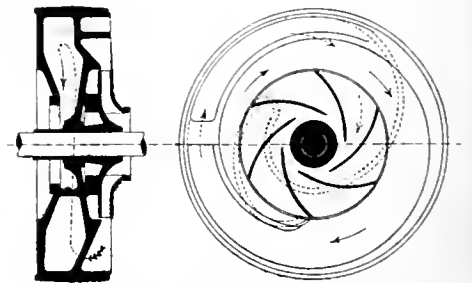

Fig. 8. Single "Cell," Single Passage Only.

SECTIONS SHOWING TYPES OF TURBINE PUMP GUIDE VANES.

surfaces is necessary. For best efficiency the throat of the passage at least, if not the entire passage, should be gun-metal

Type (b) has certain advantages for machining, etc., but probably requires a stiffer shaft. Also, having no central sup-

ports, it tends to rotate the suction water of the next impeller and may be attended by greater stage leakage due to the increased annular running clearance.

Type (c) has the paper advantage of being in balance; actually it is a poor approximation to a balance. Disturbing factors are set up by: differences in side pressure on the impeller due to differences in volume and surface-form of the water contained on the two sides of the impeller, Fig. 18; difference of quantitative leakage through the two shoulders; and high-pressure leakage into one-side of the impeller from the stage above, and leakage from the other side of the impeller to next low pressure stage below. Therefore, in practice, it is necessary to provide an additional end balancing device of the hydraulic type, or a mechanically positioning fitting such as a thrust-collar or ball-bearing; a method, especially for mine usage, not to be recommended.

The internal design of all impellers is governed by the same controlling features:—

power and size of motor, the combination will generally come out cheaper.

The maker who elects to change his impellers and diffusers to suit the de-

the inlet tip itself, and it usually varies between 15 degs. and 30 degs. If we select to use always 15 degs. we might suffer in some cases to the extent of 3

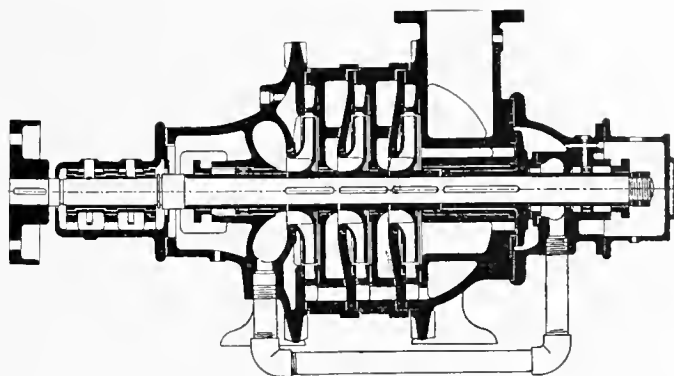

FIG. 12. MODERN FORM OF TURBINE PUMP (MATHER & PLATT).

Fig. 9. (Marchand).

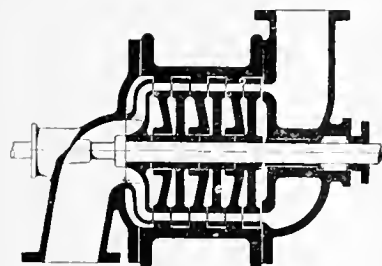
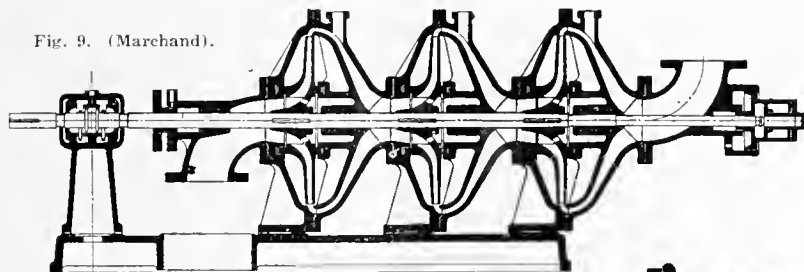

Fig. 11. Combined Axial and Spiral Flow.

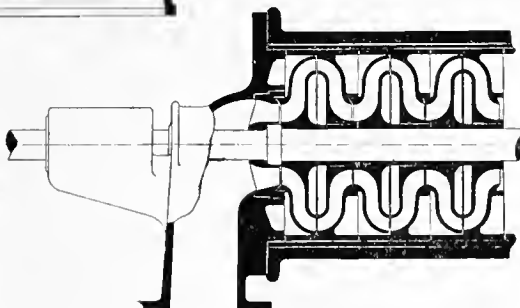

Fig. 10. Combination of Tangential Axial and Radial Flow (Escher Wyss).

SECTIONS OF TURBINE PUMPS SHOWING COMBINATION PASSAGE ASSEMBLIES.

- 1.—The entrance or inlet angle of vane.
- 2.—The delivery or exit angle of vane.

The entire design must, while based on these considerations, consult the convenience of the workshop to the utmost degree possible without departing from required dimensional accuracy. The standing difficulty with turbine-pumps, from the manufacturing point of view, is their constant variation to meet the infinite number of conditions of varying head, speed, and quantity encountered in practice. Whatever efforts are made, it seems impossible to keep to a small number of standard impellers if the highest efficiency is to be reasonably well reached each time. Efficiency, it should be noted, is really the prime factor in design and not apparent first cost, for the pump is very often driven by an electric motor of greater value. If, therefore, by the use of a pump of higher efficiency, a reduction is effected in the necessary

though the latter may have reduced costs by making in large quantity. In considering if in any way it is possible to meet the designer's requirements without losing all the advantages of repetition manufacture, we may first take the in-

per cent. or 4 per cent. If we take two sizes, 15 degs. and 25 degs., and make a liberal provision of inlet width, or, as some designers phrase it, make an adequate allowance for "weir coefficient" at entrance, we shall only drop perhaps 1 per cent. in exceptional cases; so it seems possible to do something in the way of standardizing the inlet angle.

Current Ideas Concerning Inlet Angle

One might refer, in passing, to some of the current ideas concerning the inlet angle and the condition of the water at entry to the impeller. Some designers have maintained that very great accuracy of the inlet angle is vital to high efficiency, in spite of the fact that in the ordinary unobstructed eye it is impossible to say what the absolute velocity and direction of the incoming water is, and therefore, to estimate precisely what the correct inlet angle should be is impossible. Further, the behaviour of the incoming water varies with every rate of flow, and the only way to foretell its condition would be to insert inlet guide-vanes; this, however, in such experiments as the author is aware of, has proved an objectionable practice and only introduces further losses in the pump. Another school holds that it is an advantage purposely to introduce a forward whirl in the water at the eye with the object of helping the water into the impeller. If such an initial whirl is used, the work necessary to create it is necessarily done

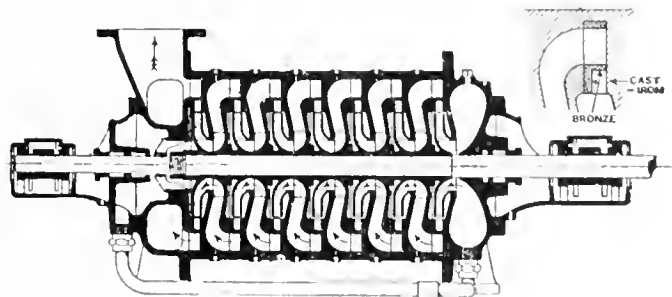

FIG. 13. (FARCOT).

let angle. This depends on the resultant of the (supposed) radial flow of the entering water and the peripheral speed of

by the pump itself, and it is, therefore, questionable if this does not entirely overweigh any possible gain.

The discharge angle depends on the resultant of the peripheral speed of the wheel and the radial out-flow, the varia-

side and out, play an important part in the efficiency of a turbine-pump. The smoother the outside surface the less the

Unequal side area. One rubbing shoulder.



Equal side areas. Two rubbing shoulders.



FIGS. 14 AND 15. IMPELLERS UNBALANCED.

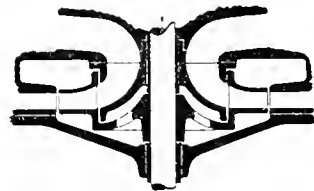
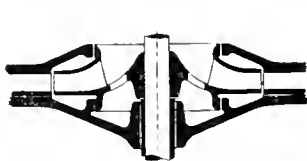

FIGS. 16 AND 17. IMPELLERS BALANCED.

tion of which is so great it seems impossible to devise any standardization. To meet quantity variation two widths of impeller may be used, and to meet required speeds of revolution it is usual to allow a small percentage variation in the impeller diameter to suit special demands; this latter, however, is conveniently done without pattern or casting alterations.

The foregoing considerations lead to the conclusion that nothing less than a special core-box will be required for each case, and it is quite usual to meet the difficulty in this way. Evidently, however, a most valuable appliance would be a special form of core-box, which in itself was more of a standard and could be adopted for manufacture in quantity; this result might be effected by fitting in vanes of a flexible nature, so that the necessary alteration and adjustment would not be great, and the whole outfit would come out cheaper than if a pattern-maker had to build a fresh box and fittings for each new demand. As the accuracy and smoothness of the impeller is of great importance, the author has always looked to machine moulding, and to a special machine like a wheel-moulding machine, for the purpose; he has not,

power lost in disk friction, and the less the power wasted in revolving idle "dead-water." An interesting point to note is that the greater the speed of revolution

sages of the impeller, it is usual practice to clean up the surfaces as well as possible with file and scraper. Impellers have been built up with one loose side so as to permit of machining or more effectively cleaning the interior; and it is evident that with individual impellers producing high heads the results would well repay the extra cost. Objections to this practice are the difficulty of making attachment of the two parts and the extra weight necessary to provide attachments.

III.—Balancing Appliance

The experienced designer knows, from practical knowledge, that even if a group of impellers, or even a single impeller, is theoretically balanced by equivalent areas subject to pressure, it will not in actual practice be free from all end thrust. Apart from variable leakage at the two sides of an impeller, which, by the way, is the principal cause of end thrust, we often have variable side surface both of the impeller and the cell chamber. If the conditions of capacity or surface of the two clearance-chambers vary, the resulting pressures will vary and an axial

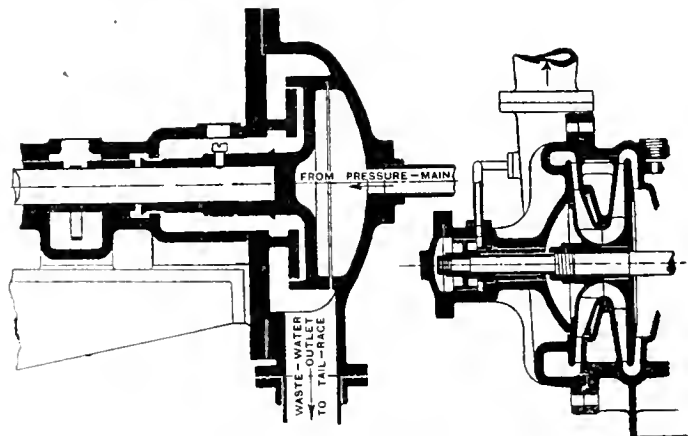

FIG. 19. HYDRAULIC AXIAL BALANCING DEVICE (FRANCIS).

FIG. 20. PUMP (RATEAU) SHOWING HYDRAULIC COMPENSATOR.

of the "dead-water" (that is, the greater the power absorbed in this way), the less the leakage from the periphery of the impeller; but a little consideration

thrust is set up. Professor Gibson has investigated the effects on efficiency (power lost) due to varying the side clearance of the impeller, and he took readings of circumferential pressures set up by revolving disks, but he apparently did not plot out the resultant effect in end-pressure. This interesting problem is discussed in a paper by F. Zur Nedden, where use is made of the results from both Professor Gibson's and Professor Unwin's revolving disk experiments. The general effect of the gyrotory pressures set up is indicated in Fig. 18. It is seen that the speed of the revolving "dead" water at the two impeller sides sets up pressure in opposition to the leakage pressure from the impeller-tip, as already pointed out; the faster the water revolves the greater the resistance to leakage, and the less the resultant pressure due to that leakage. It can readily be seen, therefore, that the effect of the chamber at one side of a wheel having greater capacity than the other, or having more obstructions in the way of ribs, pockets, or exceptional roughness, etc., plays some part in the determination of end-thrust.

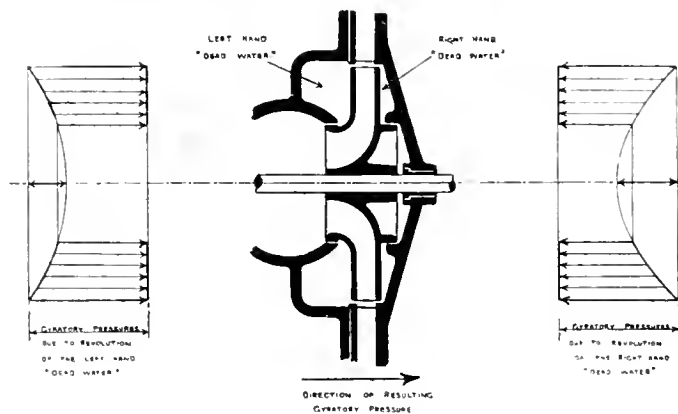

FIG. 18. EFFECTS OF GYROTORY PRESSURE ON END THRUST.

however, as yet, arrived at the final design for such.

Impeller Surfaces

The surfaces of the impeller, both in-

will show that greater overall economy is gained by reducing the wasted power in idle revolution to a minimum. As regards the internal smoothness of the pas-

All the earlier turbine-pumps employed some form of thrust bearing, either of the collar or the ball type, to keep the impellers in correct alignment with the guide passages, and it was not until much trouble had been experienced with these that hydraulic control was ultimately adopted. Experience showed that much higher end pressures were set up than were ever anticipated, but for a period

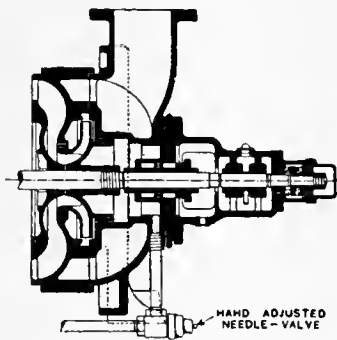

FIG. 21. HAND ADJUSTED BALANCER.

spindle itself and actuated by the same means. Further reference to the final balancing appliance (diagrammatically shown in Fig. 23) will be made shortly.

In 1906, Messrs. Sulzer brought out their device for relieving thrust shown in Fig. 24, and the principle used has been followed by many other makers and introduced with many variations. The action of the Sulzer device is simple; it

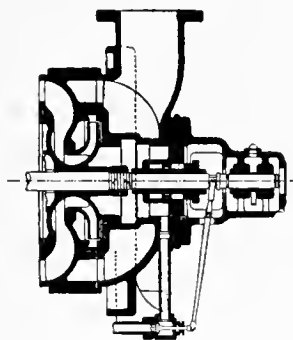

FIG. 22. MECHANICALLY ADJUSTED BALANCER.

mechanical devices were persisted in, improvements being made attempting to withstand the excessive loads, and scant notice, it would appear, being taken of water-turbine practice where for many years it had been the custom to relieve axial thrust hydraulically. Fig. 19 illustrates an hydraulic balancing device in use on Francis turbines, and which, if properly proportioned, is automatic, and thus embodies all the essential points of many present turbine-pump balancers. One should bear in mind that the relation between the calculable axial thrust and the thrust realized in a water-turbine is much closer than in a centrifugal pump of the multi-stage type, the reason of this being that the disturbing factor in a high-lift pump is the leakage from stage to stage.

The well-known application of turbine-pumps to high lifts by Messrs. Sulzer at Horeajo Mines in 1898, was carried out with back-to-back impellers, and a ball thrust-bearing was provided to take the end-thrust (in one direction only), which is inseparable from this arrangement of impellers. In 1901, Professor Rateau was manufacturing pumps with end-thrust approximately eliminated hydraulically by his well known method of shroud reduction, and provided with a balancing piston, Fig. 20. This method was not automatic, and the pressure on the piston could only be adjusted by means of a hand-operated throttle-valve. However, this was the first step, and the automatic control of the necessary pressure on the balancing device and determined by the end movement of the spindle followed as a matter of course. The development of the differential type of balancer carried out under the author's direction in 1913, extended over several years, progressing step by step from a hand-adjusted needle-valve, Fig. 21, regulated to produce the required balancing pressure, to a mechanically-operated needle-valve, Fig. 22, actuated by the axial movement of the spindle, and then through several forms of rotating throttle-valve disposed on the

comprises a single plate with a throttling device, through which the pressure water has access to the plate. The area of the plate is sufficient when acted on by a somewhat throttled delivery-pressure to overcome the tendency of the rotor to travel in the opposite direction. As the pressure gradually rises before the plate, its increased power carries the rotor to the right until further motion is arrested by the escape of the increased pressure through a widening annular space between the plate and its facing seat. An ultimate running position is reached when the leakage through the clearance between valve and seat is suf-

ficient to say that the devices adopted resolve themselves into two basic forms:—

(a) Single acting (simple), of which the Sulzer, Fig. 24, is the general type.

(b) Double acting (differential), of which Fig. 23 is the type, and Fig. 13 a modification.

Other single-plate forms are shown in Figs. 25 and 26. In the first of these the throttling agent, a small nipple, is removed to the discharge side of the plate, thus giving, in a measure, a double action to the plate; the quick action and limited travel due to the second face of the differential type is not obtained, however, and there is a possible disadvantage in the small aperture when dealing with impure water. The second example combines some of the points of both forms of balancer, but as the pressure in the spent-water chamber is always augmented by high-pressure leakage into the low-pressure side of the plate, the device is, obviously, relatively extravagant in leakage water, and must therefore be considered inefficient.

The general effect of wear on single-plate balancers is increased leakage, the outcome of which is further end-movement in one direction until finally the impeller discharges do not match their guide-vane entrances, but become off-set. This tendency in hydraulic balancers led the author to devise form "b," or the double-action control with which such difficulties are overcome.

Fig. 23 (also in Fig. 12), finally shows the present standard double-plate or compound differential balance arrangement. The balance-piston and regulating valve are combined, and form a balance-disk with two active throttling surfaces floating between two fixed seatings with

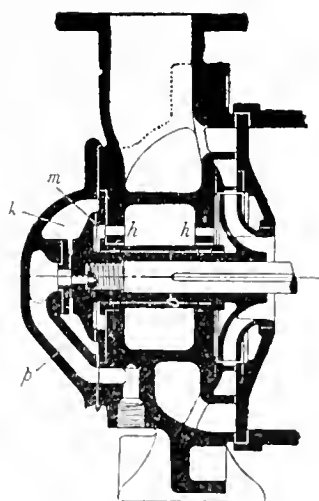

FIG. 23. DIFFERENTIAL HYDRAULIC BALANCER.

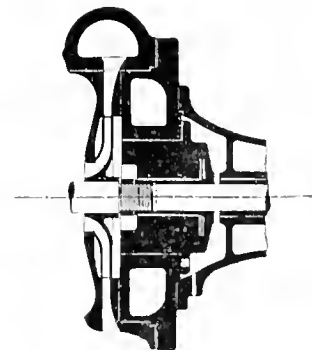

FIG. 24. SINGLE PLATE BALANCER (SULZER).

ficient to maintain a pressure at the back of the plate, equal to the set of the rotor in the opposite direction. It will be seen that the balance is quite automatic in its control, end-movement in either direction taking place until stability is reached.

Without going further into the detailed evolution of automatic control of the hydraulic end-balance of the turbine, it

a minimum clearance. All the working faces are arranged vertically so as to be independent of possible vibrations of the rotary system. The pressure-water, escaping from the rim of the last impeller, passes through the holes h, into the pressure chamber m, from which it escapes along the throttling surface of the balance-valve into the regulating pressure-chamber k, and from there, past the

small throttling surface into the escape-pipe p, leading preferably to an open drain, or, back into the suction-chamber of the pump. The double-plate balance appears to be the most sensitive automatic balancing device in practical use, for by it, closing up of the plate on the

of close-running, so that the appliance can be readily repaired after wear has taken place. As regards the best material to be used for the renewable part, some considerable experience is needed before a decision can be made. Gun-metal was probably the first material to

provided at the end of the suction-pipe, the whole rotor is forced towards the suction-end of the pump as soon as the foot-valve closes and the head pressure comes on. The reason for this is that the area of the balances on the outlet side is greater than on the inlet side by an amount equal to the diameter of the spindle. For this reason, the waste water from a balancer should not be connected to the suction-pipe of a pump, or means should be taken in the pump to equalize the areas subject to the static hydraulic pressure (Fig. 12).

IV.—The Rotor

As is well known, the internal design of a multi-stage turbine-pump involves a rotor comprising a number of impellers keyed on to a shaft, the shoulders or bosses of which abut on each other and are secured and maintained together by double nuts or the like at, or near, the ends of the shaft. Such portions of the shaft as are not covered by the impellers, but are subject to the action of the pumped liquid, are protected by sleeves which fit up to the impeller bosses and thus make a complete sheath outside the shaft itself, Fig. 1 (b), and Fig. 2 (a and b), etc.

This rotor revolves within the guide-chamber and housing, each impeller running at some points in the closest proximity to the partitions dividing the pressure-stages and return-guides.

These so-called running joints or neck-rings must be so maintained by design and construction as to secure in continued service the smallest possible hydraulic leakage-back from stage to stage, or mechanical loss by rubbing friction, both of which effect the efficiency and wear and tear of the pump. As a question of practical importance, the design of this combination probably follows next to that of the successful automatic hydraulic balancing of the axial end-thrust. We have in it the question of the deflection of the pump-shaft; the reinforcing effect of the surrounding impellers; the support afforded by the bushes, if any, between each stage, and the loss by bush friction (wear); the form of neck ring to reduce leakage; and the effect of keyways and keys, etc., all independent of each other and affecting the whole.

The ideal condition is that of a rotor supported in lubricated bearings with a shaft of such sufficient stiffness between supports that the deflection, under all possible running conditions, is less than the clearance allowed at the neck rings and intermediate bushes, so that no contact takes place between the rotating and the fixed members, this clearance at the neck-rings and intermediate bushes being kept down to the smallest possible limit. It will be seen that it is impossible to present mathematically, the exact conditions with such a number of ineluctable factors to take into account.

For instance, it may be thought that a not inconsiderable reinforcing effect is obtained by the combination of the impellers outside the shaft as a whole. In practice, however, it is not advisable to lock up the impellers together shoulder to shoulder against each other by the

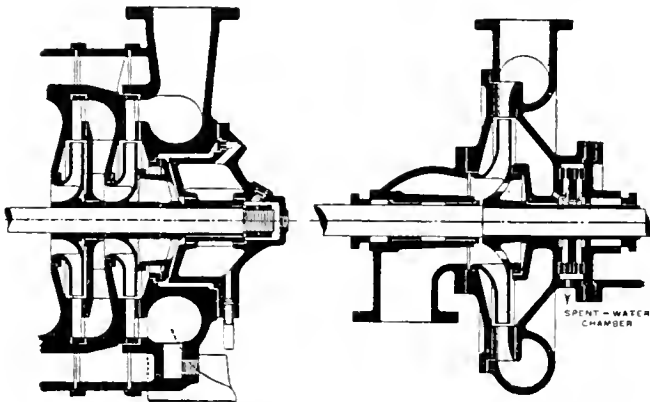

FIG. 25. (MILLINGTON)

FIG. 26. (SCHEURMANN).

SINGLE PLATE BALANCERS.

large throttling face causes an opening out on the small one, thus multiplying the balancing effect; a movement of a thousandth part, or so, of an inch being all that is required to counterbalance the most extreme and sudden changes of the hydraulic equilibrium of the pump. The other and most important feature of this auto-plate balance is that it always maintains the central position of the impellers, even if the throttling surfaces become worn, as is invariably the case when pumps are working on gritty water.

A continental form arising out of this type is shown in Fig. 27, and it is obvious that the same remarks concerning extravagance in leakage water apply to this example as to Fig. 26. The arrangement of the balancer at the end of the spindle outside the external bearings is not a good one, for the reason that a high-pressure gland at the delivery end of the pump is still required, and an additional gland also for the balancer-housing. A single-plate balance made by the same firm as the above is shown in Fig.

be used, but cast-iron, cast-steel, and hard bronze have all been tried, the present practice usually being to fit hard bronze. The ideal material is one which is hard and "short," and has a very low coefficient of friction when working in water; a material which "drags" is quite unsuitable, and apparently an incorrodible iron, one containing a high percentage of silicon or a nickel steel, seems to best fit the requirements. Non-metallic substances, such as red-fibre, woodite or dexine, have been considered, but any material which becomes slightly absorbent after long immersion is useless.

Sometimes difficulty is experienced in starting up large turbine pumps on account of the large diameter balancer-rings being held together in metallic contact instead of being apart in their usual running position; the result is an abnormally high starting torque for the motor and probable damage to the faces of the balancing device. When a turbine-pump with differential balancer is "stopped," the rotor will always take up a

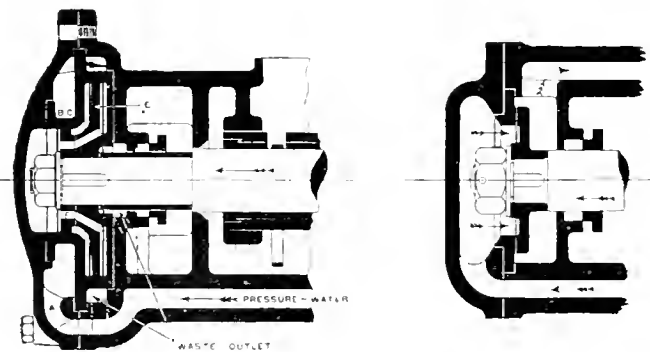

FIG. 27. DIFFERENTIAL.

FIG. 28. SINGLE PLATE.

CONTINENTAL HYDRAULIC BALANCERS.

28, and this, too, is open to the same objection as regards disposition on the spindle.

It is usual to make hydraulic balancers with renewable faces at the points

position with the balancing faces apart if the waste-water outlet (Fig. 29), is taken to an open drain; however, if the spent water is led back to the suction pipe of the pump and a foot-valve is

end-nuts in order to get the advantage of the reinforcing effect; because, due to, amongst other things, the slight inaccuracies of manufacture in squaring the shoulders of the impellers, sleeves, etc., the result would be to throw the combination out of truth, that is, to distort the shaft.

It might be contended that this need not be so, but even then provision must be made for dismantling in a mine or similar place, with its obvious attendant disadvantages, and the possibility of rough treatment taking place; furthermore, as a safeguard against heating up and consequent expansion of the outside combination (bronze) against the internal (steel) shaft due to accidental contact with the intermediate bushes, running, perhaps, when the pump is empty, suitable expansion should be allowed for, and the impellers, to ensure this, must not be locked tight against each other.

The supporting effect of the bushes on the shaft, in passing through the diaphragm intermediate between the impel-

with the fact that we are practically dependent on the shaft itself for the necessary strength and stiffness to allow of fine internal clearance, and the importance of a good design which will economically give the minimum deflection of spindle at once becomes apparent. The factors affecting the deflection of a turbine-pump spindle are:—

Static

- (a)—The weight of spindle and distribution of diameter change;
- (b)—The weight and distribution of impellers, balancer, and parts;
- (c)—The number and span of supporting bearings; and

Dynamic

- (d)—In the dynamic condition, other incalculable forces entering into the account, such as, centrifugal forces due to the out-of-balance masses, and finally certain hydraulic disturbances.

- (a)—Should be as light as possible consistent with the necessary stiffness;

passing the guide vane. It is usual to reduce the intensity of this disturbance by arranging an odd number of vanes in the impeller relative to the guide vane, and by setting successive impellers on the shaft in such a way that the point of passing-vanes is progressive throughout the series, i.e., a "lead" is given. The resultant of these arrangements is to produce a vibrating influence, which may be torsional or combined torsional and transverse, of very high frequency and effectual intensity and which, when properly carried out, is free from practical disadvantage. The damping effect of the water film in neck bushes is appreciable in overcoming slight vibrations, as is conclusively shown by the different behaviour of a spindle when running a pump dry and when running it filled with water. In order for a shaft to oscillate, it must force liquid out of one side of a neck-ring, and the retardation offered by this action has a noticeable effect. For this reason, quite apart from the lubricating effect gained, it is always a wise pre-

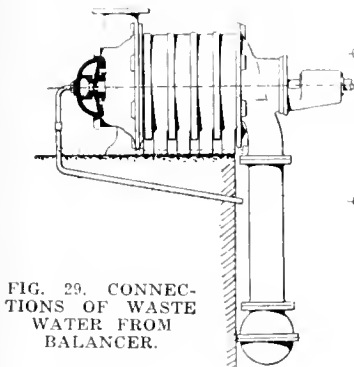

FIG. 29. CONNECTIONS OF WASTE WATER FROM BALANCER.

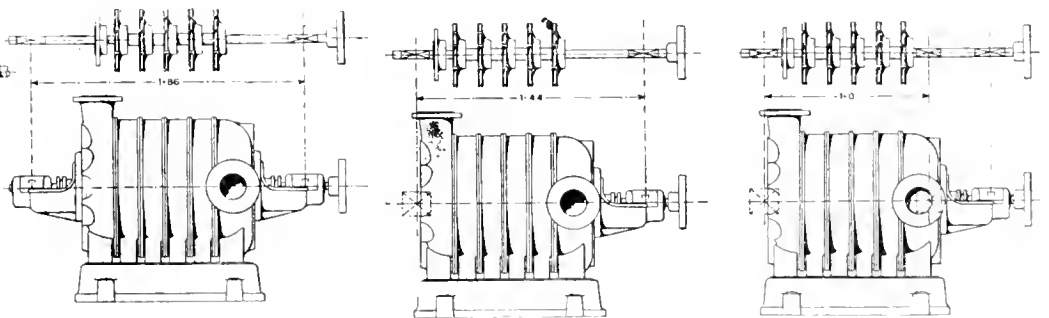

FIG. 30b. FIG. 30a. FIG. 30c. SPAN OF BEARINGS THREE ARRANGEMENTS.

lers, is very difficult to exactly allow for; it may be that the bushes will decrease the deflection of the shaft by a material amount, but it must not be assumed for one moment that they are bearings of such a nature as lubricated bearings. Intermediate bushes can only, in some cases, be considered as water-lubricated supports which will act as such so long as a certain low surface pressure on them is not exceeded; if too great pressure comes on, heating takes place on account of the high speed of rotation. The effect of wear has also to be taken into account for the hydraulic pressures at the two ends of these bushes are different and there is, therefore, always a flow taking place through them, carrying with it any sedimentary or foreign cutting matter which may be in the water. This state of things causes the supports to wear more or less rapidly so as to become almost useless, the pump eventually arriving at a condition worse than if a suitable clearance had been allowed at the first.

The author believes that too much use is made of these intermediate supports in turbine-pump design. It is found in practice that an internal bearing to be successful must have the same water pressure at both ends, and must be properly lubricated with good grease, it then gives excellent results. We are thus left

in common practice spindles are practically parallel the whole length.

(b)—Impellers and balancer should be grouped together as closely as possible, only allowing sufficient space for the water passages between the stages; also, the entire weight should be brought as close to the supporting bearings as possible.

(c)—The span of supporting bearings plays such an extremely important part in the durability of the pump; in the possibility and preservation of fine clearances; in the whirling of the shaft, and in the determination of the most economical size of spindle, that special notice will be taken of it.

(d)—A loaded shaft supported horizontally between two bearings will "sag," and when rotated must suffer bending at every revolution. Also, there are bound to be certain out-of-balance masses in the rotor due to keys, heterogeneous composition of material, and the unavoidable variation in thickness of castings, etc. In addition, a shaft has vibrational periods due to its length and diameter, the whole question of vibration being intensely complicated by the loading and supports.

In addition to the disturbing factors mentioned above, vibrations are set up from the reaction of the impeller vane

caution to fill a pump with water before running it, otherwise if the shaft is not a stiff one seizing-up will probably occur. The remedy for spindle vibration due to any cause whatever is always a stiff shaft.

The whole matter of whirling shafts has been examined by several investigators, prominent among whom is Professor Dunkerley, but it is not proposed to discuss the matter further than to refer to the general proportions affecting the critical speeding of whirling. We find that the length (l) of span of bearings, and the diameter (d) of the spindle have an effect varying as:—

$$\frac{d^4}{l}$$

Turbine-pumps do not usually run at speeds approaching the critical speed, but the maximum safe speed for any rotor will bear a direct relation to the critical speed, in the sense that it will be an equal factor for equal safety. The above relation shows then, that for a fixed critical speed a reduction in the span of the bearings results in a material reduction in the necessary shaft diameter. The effect of axial thrust—always present in a turbine-pump—in lowering the critical speed of a spindle should always be borne in mind

High Pressure Air Compressor Design and Application*

By Joseph M. Ford

Compressed air at high pressure is becoming an increasingly important medium in modern engineering practice and in naval warfare. The accompanying paper deals with the machines which produce high pressure air, leaving on one side the question of power transmission by compressed air. In passing, the principal advantages of this system are referred to, and will be seen to be of considerable value. They consist of the facility with which energy can be stored; the unlimited rate at which accumulated energy may be converted into useful work; and, apart from loss of efficiency, leakage cannot cause any awkward consequences.

THROTTLING

IN a compressor which has its suction throttled, the volumes dealt with by the stages are of course reduced, which naturally involves a decrease in stage pressures. In a compressor with no cylinder clearances there would be no limit to the possible compression ratio in any cylinder; that is, the initial pressure in, say, the high-pressure cylinder could be very low and yet the machine would deliver air. In a cylinder with a large clearance, however, there is obviously a definite limit to the ratio of compression if air is to be delivered. If this ratio were exceeded, the air would simply be compressed into the clearance space and re-expanded. In other words, in order that the compressor shall deliver air, the intermediate-pressure delivery pressure must attain a definite figure, so that the total work is still divided between the stages, although not necessarily in correct proportion. The theoretical minimum initial pressure from which a cylinder can compress and just deliver (assuming no leakage) can be obtained from the equation:—

$$c \left[\left(\frac{P_1}{P_2} \right)^n - 1 \right] = 1$$

where

- c is the clearance ratio,
- P_1 is the delivery pressure (lb. per sq. in. absolute),
- P_2 is the minimum initial pressure (lb. per sq. in. absolute),

and

n is the exponent in $P V^n = \text{constant}$.

The above expression shows that P_2 increases as c is increased, and that with large clearances the compression ratio in any stage when the compressor is running throttled can be kept within limits, whereas in a machine having very small clearances the high-pressure compression ratio, with excessive throttling, might reach an abnormal figure, resulting in excessive temperatures in that cylinder. The foregoing would tend to show that a compressor with good clearance volumes is preferable to one with small clearances, and for some Diesel engines — especially those of the marine type, where the conditions under which the compressor works may vary between fairly wide limits—this is the case.

As previously mentioned, clearance results in a reduction in the effective capa-

city of a cylinder, so that larger cylinders must be fitted than would be necessary with no clearance volume. The direct result is an increase in the piston loads. For example, a compressor of 300 cub. ft. per minute displacement at 350 r.p.m., having stage pressures of 45 and 300 lb. per square inch, when working at 900 lb. per square inch delivery pressure, and cylinder clearances for low pressure, intermediate pressure and high pressure of 4, 5 and 10 per cent. respectively, has a maximum air load on the high-pressure piston of about 7,900 lb., whilst the maximum intermediate pressure piston load is 14,300 lb. In a similar machine having, however, low pressure, intermediate pressure and high pressure clearances of 4, 15 and 30 per cent. respectively, the high-pressure piston load is increased to 12,100 lb. and the intermediate pressure load to 22,800 lb. Figs. 12 and 13 give for various clearance ratios the maximum piston loads for compressors of the above capacity and stage pressures.

and 13. Inspection of the diagrams super-imposed shows that as the clearance is increased the commencement of delivery and the commencement of suction, in both the intermediate-pressure and high-pressure cylinders, occur later in the stroke. With a large clearance, therefore, the maximum cylinder load is not attained until the crank is at a somewhat smaller angle from the dead centre than would be the case in a machine with no clearances, due to the fact that the actual compression takes place during a longer portion of the stroke, and further, the re-expansion of the greater volume of clearance air occupies a larger portion of the stroke, so that the pressure acting on the piston does work on the crank through a greater angle than it would were the cylinder clearances small. The crosshead load (neglecting inertia and weights of parts) at any point in the stroke, for the particular type of machine under consideration, is the difference between the intermediate-pressure piston load acting upwards and the low-

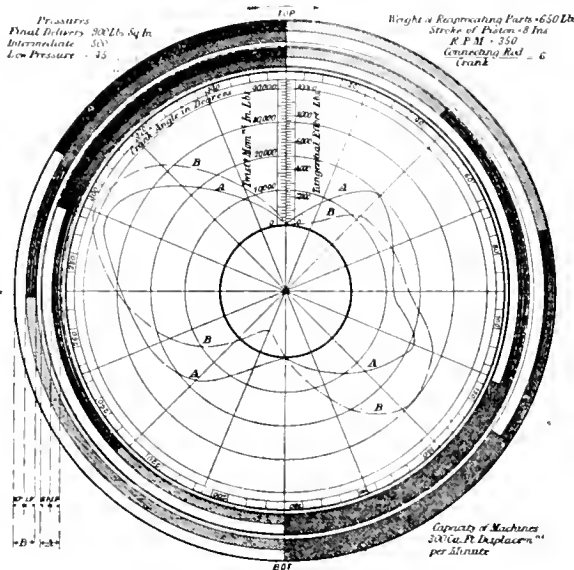

FIG. 15.

Diagram of twisting movements and crank angles for various events of the cycle. A—For a machine with clearance volumes—L.P. 4 per cent., I.P. 5 per cent., H.P. 10 per cent. of volume swept. B—For a machine with clearance volumes—L.P. 4 per cent., I.P. 15 per cent., H.P. 30 per cent. of volume swept. Final delivery period, black; re-expansion of clearance air, single hatching; suction from intercoolers, circular hatching; transfer periods, cross hatching; compression periods, blank. The diagram from the L.P. points will be practically identical for the two machines, and is therefore not given.

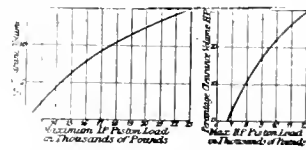

FIG. 12. FIG. 13. Diagram showing effect of clearances on piston loads for a given output at a given pressure.

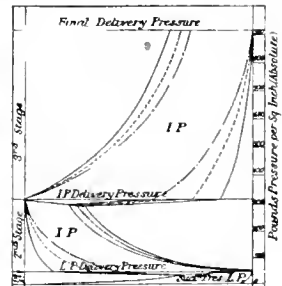

FIG. 14. Combined diagrams for three machines designed for same output and stage pressures. For a machine with clearance volumes—L.P. 4 per cent., I.P. 5 per cent., H.P. 10 per cent. of volume swept by piston. For a machine with clearance volumes—L.P. 4 per cent., I.P. 10 per cent., H.P. 20 per cent. of volume swept by piston. For a machine with clearance volumes—L.P. 4 per cent., I.P. 15 per cent., H.P. 30 per cent. of volume swept by piston.

Fig. 14 shows the combined indicator diagrams for three machines, whose pressure characteristics are shown in Figs. 12

and 13. Inspection of the diagrams super-imposed shows that as the clearance is increased the commencement of delivery and the commencement of suction, in both the intermediate-pressure and high-pressure cylinders, occur later in the stroke. With a large clearance, therefore, the maximum cylinder load is not attained until the crank is at a somewhat smaller angle from the dead centre than would be the case in a machine with no clearances, due to the fact that the actual compression takes place during a longer portion of the stroke, and further, the re-expansion of the greater volume of clearance air occupies a larger portion of the stroke, so that the pressure acting on the piston does work on the crank through a greater angle than it would were the cylinder clearances small. The crosshead load (neglecting inertia and weights of parts) at any point in the stroke, for the particular type of machine under consideration, is the difference between the intermediate-pressure piston load acting upwards and the low-

*Part II. of a paper read before the Greenock (Scotland) Association of Shipbuilders and Engineers.

pressure and intermediate-pressure cylinders tend to balance one another to some extent. The result of this is that although the actual piston loads are considerably increased with large clearances, yet the maximum turning moment is augmented to a much less extent.

Fig. 15 gives the turning moment diagrams for two of the three compressors previously mentioned, namely, that with the 10 per cent. high-pressure clearance and that with the 30 per cent. high-pressure clearance. It will be seen that the maximum value occurs in this case when the crank is about 65 deg. from top centre. The comparatively small increase in maximum turning moment with the larger clearance, compared with the increase in the actual piston loads, is to be noted. The effect of the increased clearance volumes on the crank angles at which the various events of the cycle occur is also clearly seen.

Fixing of Stage Proportions

When a machine is required to deliver a given quantity of air at a given pressure, one of the first decisions concerns the number of stages in which the compression should be effected. The main factors are: the initial cost of the machine, reliability and economy in operation, and safety in operation.

The initial outlay increases as the stages are multiplied. With a small machine the gain in economy and safety in operation due to increasing the number of stages is of less importance than in a large one. Cooling will be more effective due to the smaller cylinders, and the castings will probably be more reliable, thus lessening the chances of breakdowns. In addition, piston leakage in a small two-stage machine will probably be much less than in a three-stage machine of similar capacity, because in the former there will only be leakage past two sets of rings, whereas in the latter there are three sets. Moreover, the high-pressure piston in the two-stage compressor will obviously be larger than that of the three-stage one, so that the piston rings are much more likely to be airtight. It is a recognized fact that in practice small rings, in spite of the smaller circumference, are more difficult to make tight than large ones.

The necessity for reliability demands, for reasons previously mentioned, that the temperatures in the cylinders be kept as low as possible, which in large machines, where the cooling is comparatively poor, demands division of the compression into several stages.

An important point in the computation of stage proportions is to arrange as far as possible for equal temperatures in each stage, for then the highest temperature is a minimum. Theoretically, this can be attained by dividing the work equally between the stages—which also results in the minimum of work required per unit of air compressed. In practice this is only true when the cooling effect is the same for all stages and the intercooling perfect.

Fig. 16 shows the theoretical theta-phi diagram for a three-stage compressor de-

livering air at 900 lb. per square inch gauge pressure. With equal division of work between the stages and intercooling down to the initial atmospheric temperature, the heat equivalent of the work required per lb. of air is represented by the area under ABHMPGR down to the line of absolute zero temperature (diagonal shading). The cooling effect is assumed to be the same for all stages, and as a result it will be seen that the maximum temperatures attained are the same for each stage of compression., 260 deg. F. The distance a, b, and c are, of course, equal, since the compression ratios of the stages are identical.

Supposing that, owing to restricted water supply, climatic conditions, or circumstances connected with the design of the machine, it is found that in the first stage intercooler the air can only be reduced in temperature to 90 deg., and in the second stage intercooler to 120 deg., then the diagram is modified as shown by the dotted lines. The heat equivalent of the work required per lb. of air will then be represented by the area under ADJLOGR down to the line of absolute zero temperature, the excess over the previous case being represented by the horizontally shaded portions. The temperatures attained in the stages are no longer equal, but increase towards the final delivery. In this case they are: low pressure = 260 deg., intermediate pressure = 300 deg., high pressure = 340 deg. The compression ratios of the stages are, however, still equal.

With the poor intercooling, even, the maximum temperature of the cycle can be reduced by changing the distribution of work between the stages.

If the compression ratios in the various stages are made in the proportion $x : y : z$ (see Fig. 16), then the stage temperatures will be the same, and consequently a minimum, although the intercooling is bad and the work distribution unequal.

The modification to the temperature-entropy diagram for these latter conditions is indicated by the chain-dotted lines, and the work in this case is the area under ACFKNER down to the absolute zero of temperature line. This is found to be slightly less than that required for the previous case, in which the compression ratios were equal. In some cases, therefore, better results are obtained from an unequal distribution of work than would be the case were each stage given an equal share, and also it may be pointed out that probably more valve trouble results from excessive temperature than from any other cause.

The design of certain machines is such that the cooling in some stages is likely to be very much better than that in others, in which case the work in the well cooled stages can be increased, and thereby relieve to some extent the stages with inefficient cooling.

Fig. 17 shows approximately the entropy diagram which would be obtained from a test on one of the machines previously referred to, namely, that with the low-pressure clearance 4 per cent., intermediate-pressure 15 per cent., and

high-pressure 30 per cent. of the piston displacement.

It is not proposed to enter into the question of the application of the theta-phi diagram to air compression. The peculiar shape of the lines representing the change from the initial condition to the final condition at end of compression is due to the transfer of heat from the cylinder walls after compression has commenced and to the heat added to the air as a result of piston friction. The deviation to the right of the vertical indicates that the air temperature is rising even faster than with adiabatic compression as a result of the addition of the said heat. Later on in the stroke cooling sets in and the compression becomes further removed from the adiabatic, shown by the line bending over to the left.

The atmospheric temperature is assumed to be 60 deg. F. The point "X" represents the initial condition of the air in the low-pressure cylinder just before compression begins, and it will be observed that the temperature has been increased by the amount Δt_1 (in this case 20 deg.), the increase being due to the fact that the air on its way to the cylinder has become heated through contact with hot valves, etc. In this particular case, with a mechanically controlled suction valve, the initial pressure is seen to be very slightly above 14.7 lb. per square inch, due to the inertia of the moving column of air in the suction pipe.

The first stage compression is carried to 59.7 lb. per square inch absolute and the temperature rises to 320 deg. F., the large rise being due to the fact that cooling is rather bad in this stage, partly as a result of a large portion of the "cover" being occupied by the high-pressure cylinder and the rest by large delivery valves, so that cooling cannot well be applied to this part. From the diagram it will be seen that the resultant compression is almost adiabatic.

After the first stage of compression the air is cooled in the intercooler to 80 deg. F., but on entering the second stage cylinder it again increases in temperature Δt_2 due to the hot piston, passages, etc., and also as a result of mixing with the re-expanded clearance air. The restriction in the intercooler tubes and in the valves results in a pressure drop, so that the initial second stage pressure is somewhat lower than the low pressure delivery pressure.

The total effect, then, of the above is that the initial condition in the second stage cylinder is represented by point "Y" instead of point "J," as would be expected.

It is assumed that the large clearance space in the intermediate-pressure cylinder is well cooled, and this, together with the good packing effect, results in the compression being further removed from the adiabatic than it is in the low-pressure cylinder, so that in spite of the considerably greater share of the work done by the intermediate-pressure, the temperature of compression is not very much in excess of that in the previous stage. A similar sequence of events takes place in the high-pressure cylinder, where, again,

owing to the large well-cooled clearance, compression is within the adiabatic. This, together with the fact that the high-pressure stage has the smallest share of the work to do, results in the comparatively low final temperature of 240 deg. F.

Even with a poor distribution of work, as in this case, the temperatures need not necessarily be excessive. There are, however, other aspects of the problem of determining stage proportions. Consider the case of a high-speed Diesel engine compressor, where it is desirable that the balance and twisting moment diagram of the machine should be as good as practicable, in order as far as possible to eliminate vibration.

With a machine of a certain type, it will be obvious that the crosshead load at the top centre will be due to both the low-pressure and high-pressure delivery pressures on their respective pistons, whilst at the bottom centre the load is only that due to the intermediate-pressure pressure. The maximum upwards load is then about twice the maximum

In the remarks on clearance this question was mentioned, and the advantages of large clearances in this connection were enumerated.

The loads to which large clearances give rise (Figs. 12 and 13) might be inadmissible for various reasons, whilst the increased cost due to the larger cylinders might be a disadvantage, so that the constant proportional division of work between the stages, almost always approximately possible of attainment by choosing suitable clearances, would not in this case be secured.

If the machine runs at a pressure above its normal the division of work will be upset, and the high-pressure stage will take a considerably increased share of the total load, which may result, among other things, in an undue rise of final delivery temperature. If this latter is reasonably low when the machine is working at normal pressure, the rise due to the increased pressure will not be of such great consequence. To meet these conditions it is usual to arrange that the high-pressure stage shall, under normal

pily is very rare, due, among other things, to the attention given to the selection of the oil itself.

Volumetric Efficiency

One other point which arises in connection with the determination of stage proportions is the question of the volumetric efficiency of the low-pressure cylinder. If the low pressure stage is given a large share of the work, the effective capacity of the machine will be less than it would be with a lower first stage delivery pressure for reasons explained in the notes on the effect of clearance.

From the above it will be seen that multistage compressor design is to a large extent a matter of compromise. Each case should be treated by itself according to the duty of the machine and conditions under which it is to be run, and the best combination under the circumstances of loads, balance, and temperatures should be found, whilst the behaviour when throttler or running at various pressures must also be considered.

The question of cost should not be forgotten, for in some cases the advantages gained by, say, adding clearance, and thereby increasing cylinder sizes, may not warrant the additional expenditure.

Cylinder Proportions

Fig. 18 shows the stage pressures adopted in some of the very latest three-stage compressors for Diesel engines, by four different British and Continental builders, and bears out the remarks regarding the compromise in design of compressor.

Having decided on the stage pressures and cylinder clearance ratios, the actual determination of main dimensions is relatively simple.

When fixing the cylinder sizes, the low-pressure cylinder is settled first, as in a steam engine. A low-pressure delivery pressure is assumed—basing the assumption on previous practice if available—and from this pressure and the clearance volume in the cylinder (depending largely upon the type of valves used) the indicated volumetric efficiency is calculated. The dimensions of the cylinder are chosen such that, after the clearance air has re-expanded, the cylinder can draw in the required amount of air, plus an allowance for leakage through the compressor. Regard should also be paid to the fact that the air on its way to the cylinder, through contact with hot valves, passages, etc., becomes heated—which reduces the actual weight of air dealt with.

Where the workmanship is of the first order, about 85 to 90 per cent. of the air actually taken into the compressor will be delivered when compressing to 1,000 lb. per square inch in three stages.

The second stage cylinder is proportioned so that after its clearance air has expanded it can contain the whole of the air delivered by the low pressure at the low-pressure delivery pressure, and at the temperature resultant upon the mixing of the incoming and the clearance air. Attention should again be given to the effect of the hot cylinder cover, piston,

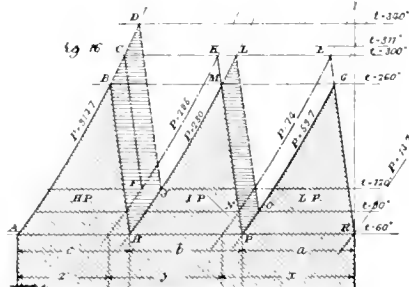

FIG. 16.

This chart may also be used to determine the ideal stage pressure (i.e. equal compressions per stage for compression to pressures up to 1,000 lbs. per sq. inch in 2 or 3 stages. For 3 stages of compression a line from the zero point to the intersection of the delivery pressure line and vertical H.P. cuts the other verticals in the ideal

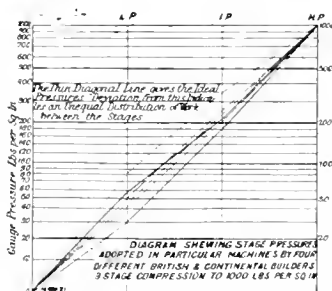

FIG. 17.

conditions, take rather less than its proper share of the total work. The temperature in the other stages will be somewhat increased, but the rise in these temperatures due to the small increase in pressures as a result of the greater delivery pressure is inconsiderable.

If the machine has to run throttled in order to reduce the volume delivered, then it is again desirable, if possible, to arrange that the high-pressure stage shall under normal conditions take the smallest share of the work, since throttling reduces the stage pressures without altering the delivery pressure, thereby resulting in an increased high-pressure delivery temperature.

The importance of keeping the high-pressure temperatures low may again be emphasized. Burning and explosion of the lubricating oil here is of great violence when it does occur, which hap-

FIG. 18. pressures. Example:—3-stage compression to 500 lbs. per sq. inch gives—L.P. pressure = 33 lbs. per sq. inch, and I.P. pressure = 142 lbs. per sq. inch gauge. For 2-stage compression join zero point to intersection of delivery pressure line and vertical I.P. The L.P. pressure can then be read off as before.

downwards load, which would not conduce to the best running.

There are two ways of bettering conditions, one of which is to retain the stage pressures and adjust the intermediate pressure clearance until the load approximates to that desired (see Figs. 12 and 13), and the other is to choose the stage pressures so that the upload is reduced and the down load increased. Increased down loads necessitate larger connecting rod bolts, which in some cases, on account of the restricted space available, might not be easily accommodated.

Provision for Variable Delivery Pressures and Volumes

Another consideration when fixing stage proportions is the possibility of the machine being run at delivery pressures higher than normal.

etc. The other stages are similarly treated.

Experience is an important factor in the settling of cylinder proportions, as in the higher stages, at any rate, it is essential that allowance be made for leakage. For example, in a four-stage machine compressing to 3,500 lb. per square inch, possibly not more than 80 per cent. of the air taken in ever reaches the high-pressure cylinder. If this cylinder is made big enough to deal with the whole of the air aspired by the machine, it would actually take considerably more than its intended share of the load.

One method of finding the volumes of the various cylinders is the "constant weight" method, which depends on the fact that (neglecting leakage) the weight of air in all the cylinders at the end of the suction stroke is the same, correction for leakage being made afterwards. Another method, which can be used graphically, is the "equivalent cylinder" method. Here the volumes of the ideal cylinders with no clearance are found, assuming the compression isothermal, and an adjustment is then made for the effect of clearance air and temperature rises.

When the cylinder sizes have been determined, the size, location and number of valves may be fixed, determining to a great extent the way in which the necessary clearance volume is made up.

Small deviations are often made from the theoretical figures for reasons of manufacture. Supposing that the calculated high-pressure cylinder diameter was 3 $\frac{3}{8}$ in., for convenience of manufacture this dimension might possibly be made the more even figure of 3 $\frac{1}{2}$ in., en-

Modern Multi-Stage Compressor Practice

Comparison with Steam Engines.—The care and consideration which must be given to the question of proportioning a compressor is probably of more importance than that required for, say, steam engine design, in addition to which the engineering practice for the successful construction of compressors must be of the highest order. In the case of a triple marine engine, the cylinder clearance volumes are of comparatively small importance, and the arrangement of the engine need not be altered to suit the clearances. Should the distribution of work be less even than as designed, it is only necessary to alter the cut-off in the different cylinders. The work done by the high-pressure cylinder can readily be reduced by cutting off earlier in the medium-pressure cylinder, but in an air compressor reduction of the high-pressure work entails the addition of clearance volume to the high-pressure cylinder, which addition it is usually almost impossible to effect.

Small errors in the calculation of steam engine design have sometimes been corrected by the introduction of packing pieces, or stepped keys in the valve gear, but with a compressor it is rarely possible to correct mistakes. The workmanship must be of the highest class, especially with such details as valves and high-pressure plungers. Piston rings and cylinder bores also call for particular attention.

A noteworthy difference between steam engine and compressor design is that, whereas with the great majority of steam engines the cylinders are double-acting,

of differential pistons, which are rarely met with in steam engines. These points give rise to a large number of possible arrangements of compressor cylinders, a few of which are shown diagrammatically in Figs. 19 to 29.

Cylinder Arrangements — Fig. 19 shows the most common arrangement of a three-stage compressor. On the down stroke air is drawn into the space marked low pressure through the suction valve, having previously passed through a silencer. On the up stroke this air is compressed, and delivered through the first stage intercooler to the annular space marked intermediate pressure, where, on the next down stroke, the second stage of compression is effected. The air is again cooled in an intercooler before passing to the high-pressure cylinder, where the final compression is carried out. Before the air is delivered to the storage bottles it is customary to pass it through an aftercooler (consisting usually of a submerged pipe), in order that the air in bottles shall not become unduly heated. This compressor arrangement is largely adopted on Diesel engines, as well as for independent plants on account of its comparative simplicity and compactness, but it has several disadvantages.

To examine or renew new-pressure or intermediate-pressure piston rings, it is generally necessary to lift the whole piston and connecting rod up through the cylinders before the gudgeon pin can be removed, which in some cases, such as in submarine engines, is an undesirable feature on account of the limited head-room usually available. It may also be noted that the low-pressure and intermediate-

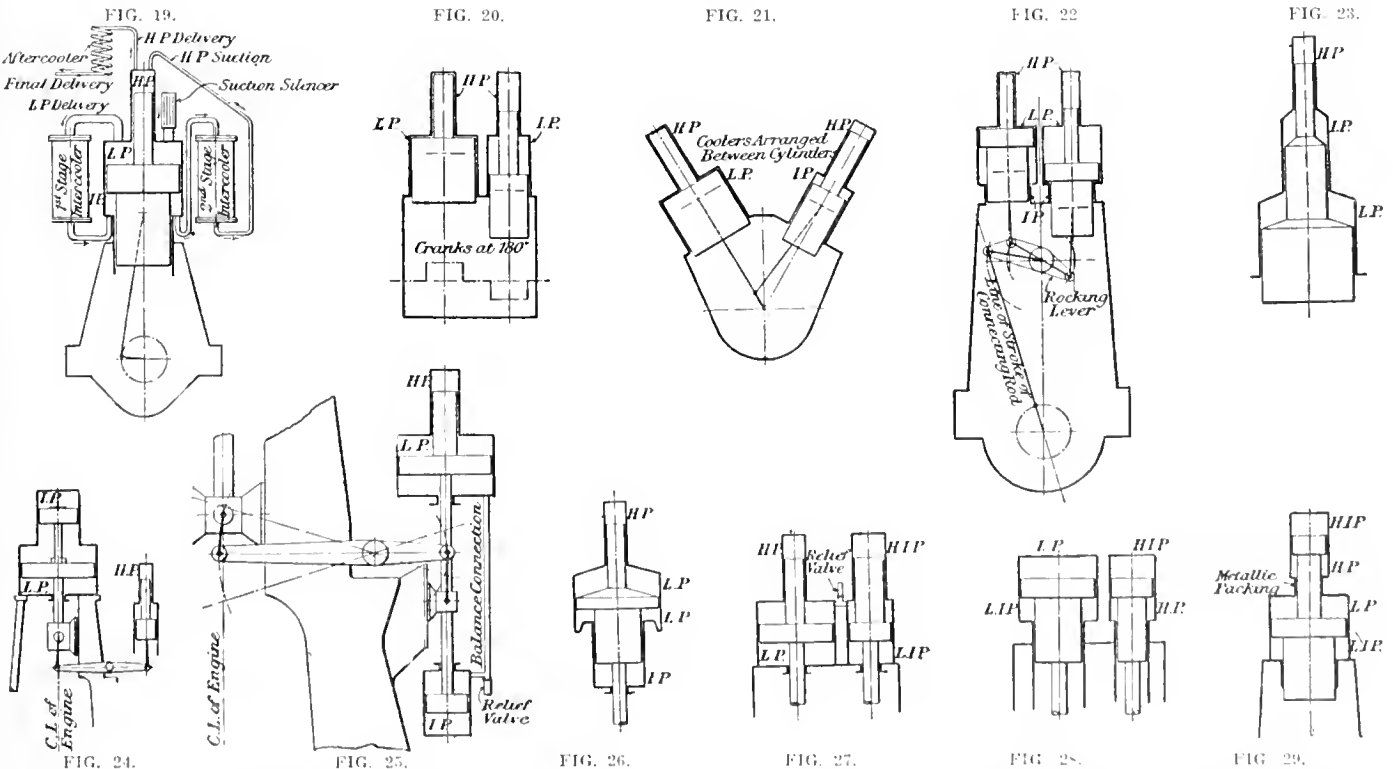

tailoring, however, an increase of 7 $\frac{1}{2}$ per cent. in the volume. Some builders, however, work to sixteenths of an inch in cylinder diameters.

in high-pressure compressor work they are invariably single-acting in the generally accepted sense of the term. Another difference is the very frequent use

pressure work is all done in the same cylinder, as it were, so that more heat has to pass through the cylinder walls to the jacket than would be the case were an

entirely separate cylinder devoted to each stage of compression. This, however, in practice is not of much moment.

Fig. 20 shows a small two-crank machine suitable for a motor-driven plant. With this type of machine the working parts are in constant thrust. A modification of this last arrangement is shown in Fig. 21, where both lines are driven by the same crank. This "V" compressor has been used on several marine Diesel engines, where the effect of the uneven turning moment resulting from this design is of but slight importance. It may be added that the angle of the "V" is usually somewhat less than that shown diagrammatically in the figure.

A curious adaptation of the type shown in Fig. 19 is given in Fig. 22. This arrangement, although expensive, has been used on some of the largest high-speed Diesel engines yet constructed, and is very satisfactory in operation. Instead of employing a single compressor, two entirely separate small machines are used, actuated from the ends of a rocking lever driven from the crank shaft by means of a single connecting rod.

A great advantage gained is a reduction in the size of cylinders necessary, which results in a marked improvement in the cooling and reliability. In addition, the turning moment of the combination is good, whilst the side thrust on the pistons resulting from the obliquity of the connecting rod in the usual design is, in this case, almost entirely absent. Another minor point to which attention may be directed is, that if a compressor valve breaks on, say, the starboard engine in a ship with this arrangement, only 25 per cent. of the main engine air supply is stopped, instead of half, as would be the case were each main engine fitted with a single compressor. As a result, it is quite likely that it would be found possible to carry on without running a big auxiliary compressor, which in many cases, being motor driven, entails the operation of a large generator set. Fig. 23 shows the arrangement occasionally adopted for Diesel engine work. Its obvious feature is its simplicity.

An arrangement which has been employed in one or two instances is shown diagrammatically in Fig. 24. Here the high-pressure stage is entirely separate from the other cylinders, and is driven by means of rocking levers. Accessibility is a feature of this design. To remove the intermediate-pressure piston it is only necessary to lift the intermediate-pressure cylinder cover and take off the nut securing the piston to the rod. By lifting the intermediate-pressure cylinder a little, it will now be a simple matter to withdraw the low-pressure piston. The high-pressure piston is easily withdrawn by putting the crank on top centre and uncoupling the link between the levers and piston. Note that the first stage of compression is effected on the under side of the low-pressure piston. This means that the heat from the intermediate pressure is well removed from the heat of the low pressure, so that the cooling is more efficient. The air in the space between the low-pressure and intermediate-pressure pistons is simply

compressed on the up stroke, and re-expands on the down stroke—a relief valve being provided to guard against excessive pressure due to piston ring leakage.

Fig. 25 gives another arrangement of compressor suitable for a Diesel engine, where the air displaced by the idle side of the low-pressure piston is passed to the idle side of the intermediate-pressure piston in a similar manner to the previous case.

In the arrangement shown in Fig. 26 each side of the large piston does a part of the first stage of compression, whilst the second stage is effected in a cylinder at the bottom, as shown. This necessitates the use of a gland subjected to a pressure of perhaps 300 lbs. per square inch as well as a high temperature, but this is of minor importance. The up and down loads are more nearly equal than is the case with the usual arrangement, and, in addition, the maximum crosshead load for a given capacity is reduced as a result of the decreased low-pressure piston diameter. It may be mentioned that this arrangement is adopted in one of the largest compressors yet built for Diesel engine work.

Figs. 27 and 28 show arrangements of four-stage compressors, suitable for torpedo air compressors. The former design necessitates glands, but permits of rather better cooling than the latter, which, however, has an advantage in that crossheads may be dispensed with if required.

A single-line four-stage arrangement is shown in Fig. 29, but this suffers somewhat from lack of accessibility, although the loads up and down can be equalized, as two stages of compression are carried out on each stroke. There are other arrangements to suit various conditions as to accessibility, compactness, balance, etc.

Cylinders and Piston Packing

The conditions under which compressor pistons run are different from those in a steam cylinder, where there is generally a certain amount of condensation and the water so formed acts as packing in an effective manner. In a compressor a little moisture from the atmosphere is present, but this is generally insufficient to permit of using, for instance, solid piston valves, as sometimes met with in steam practice. Special attention should be given to the question of piston packing, which, however perfect, is useless unless the cylinder bore is machined to within extremely fine limits, the required accuracy being greater the higher the pressure which has to be withstood. In the case of high-pressure cylinders opinion is divided as to the best means of producing the nearest approximation to the perfect bore. Some builders finish the bore by an elaborate system of reamers, and the accuracy and uniformity of the bore so produced leave little to be desired. Other manufacturers pin their faith to grinding methods, and in many cases the bore is lapped out to size. The packing used on high-pressure pistons is varied. For machines such as those used for torpedo charging, which only run intermittently, leather or some patent packing of a similar nature is used.

Any slight unevenness in the bore or lack of alignment is taken up easily, and the leakage is very small. The question of temperature should not be overlooked, for if these are too high, burning of the packing will result, and in some cases, to reduce the possibility of this as far as possible, cylinder lubrication is effected by means of a comparatively copious supply of soap-water, oil being used but sparingly.

In compressors for pressures above 2,500 lbs. per square inch it is almost universal to find leather or similar high-pressure packing, and very frequently arrangements are made for introducing a certain amount of distilled water with the suction air. There are two ways of fixing the packing, one of which is to carry it on the piston, in the same way as piston rings, and the other is to use it in a similar method to that usually adopted with hydraulic machinery—the particular method adopted depending on the arrangement of the compressor.

For a Diesel engine compressor, or any machine which has to run at full load for long periods at a time, leather is not sufficiently durable, and recourse is made to metallic packing, consisting generally of piston rings. These rings are usually made of selected cast iron, and may be of the ordinary "Ramsbottom" or other types. Some builders adopt rather elaborate packing systems for high-pressure pistons which have special properties, such as being adjustable for axial wear and being self-aligning, whilst others use plain cast-iron rings with almost equally good results.

One point in this connection which may be mentioned is that "air packing" should never be adopted with high-pressure pistons, since the high-pressure air forces out the ring against the cylinder wall, and whilst giving a splendid result as far as air-tightness is concerned, increases the wear of the cylinder. Occasionally metallic packing is used in a type of gland, with, in some cases, satisfactory results. The packing may be of the manufactured ring form, or may be shredded white metal and graphite.

Regarding the other cylinders of the compressor, equal attention should be paid to the bores as with the high-pressure cylinder. The piston packing adopted consists usually of cast-iron rings, although some manufacturers fit leather or similar packing throughout the machine. For glands under air pressure, metallic packing is preferable, as the majority of the usual packings quickly deteriorate under the dry heat to which they are subjected.

Valves

The question of the design of valves for an air compressor is one which demands careful thought and attention, for no other part is so vital to the proper working of the machine. The type of valve used in all high-pressure compressors is the automatic valve, which depends for its action on a difference of pressure above and below it, and is not actuated by any external means. This appears in countless forms, but of few can it be said that they are entirely satisfactory.

Automatic valves are essentially of a more or less delicate construction, and the conditions under which they operate are usually severe. The delivery valves have to pass air at very high temperatures, and the heat, unlike that in a steam engine, is a dry heat; whilst in a high-speed machine running at, say, 450 r.p.m., the valves have to lift and seat themselves in a very short space of time.

For example, in a low-pressure cylinder in which compression is carried to 80 lb. per square inch gauge, at 450 r.p.m. the delivery valves have to open, pass the air, and completely seat themselves again in a period which is actually less than one-sixtieth part of a second. In order that this operation shall be successfully accomplished, either a powerful spring must be used to reseat the valve, or else the lift must be exceedingly small. The result of using a strong spring is that the pressure required to open the valve is excessive, and the hammering of the valve on its seat under the influence of the spring results in very rapid wear. The alternative, namely, the adoption of a small lift, means that the diameter of the seat must be large in order to obtain the requisite area through the valve for the flow of air. It may be stated that velocities in practice through the valve may be 130 ft. per second for low-pressure valves, and may be 250 ft. per second for high-pressure valves. If the diameter of the seat is increased over that sufficient with a larger lift, the leakage is increased, owing to the larger circumference of the contact circle; and, moreover, since a large valve is more liable to heat distortion than a small one, the possibilities of leakage are still greater.

Whatever the diameter of the valve, the weight should in every case be brought to the minimum. This reduces the inertia forces, and thereby the spring strength. Consequently the wear due to hammering and excess pressure required to open the valve is decreased. The type of valve usually employed for high-pressure work is the thimble valve, which can be used either for suction or delivery, two or more being used per cylinder to obtain the necessary area of flow. The valves proper are usually of nickel steel, and the seats of best quality bronze or gun-metal, although one Diesel engine builder used to fit valves in small compressors with seats of ebony or lignum vitae. The actual seat should be as narrow as possible, in order that the unbalanced load may be reduced to a minimum.

For moderately high pressures small valves of the well-known plate type are frequently used. The plate is usually of special steel and the seat of bronze. It has been found in practice that this type of valve, at any rate in the larger sizes, is liable to fracture if the lift is too great, so that, in order to obtain sufficient area for the passage of the air and at the same time keep down the diameter, it is necessary to adopt multiple seats and to cut ports in the valve for the exit of a part of the air. Given suitable conditions, this type of valve when

properly designed and made is superior to the thimble or poppet type, especially for the low-pressure stage, but the plates are somewhat unreliable when the temperature is excessive. One advantage over the other type is that carbonisation has very little effect on the working.

A type of valve to which one prominent Continental firm have pinned their faith is the "Gntermuth" valve, which consists essentially of a strip of steel wrapped round a spindle in a similar manner to a clock spring. This has been used with great success in all the stages of Diesel engine compressors up to quite large sizes.

In high-pressure compressor work the valves must be kept in thoroughly good condition, as otherwise a leakage may take place from any stage to a lower one, thus increasing the pressure and temperature attained in the latter. This would upset the balance, and in extreme cases cause a serious breakdown by adding, perhaps, 250 per cent. to the load on the connecting rod bolts. To guard against such contingencies it is of the utmost importance that ample relief valves be fitted to all stages, and however reliable a machine may appear to be, it is dangerous to run with the relief valves out of action.

It is not proposed to deal with mechanically moved valves, as their application to high-pressure compressor work is limited, usually to the low-pressure suction, with perhaps the addition of the intermediate-pressure suction. The great advantage of a mechanical suction valve for the low pressure is that one can ensure that the cylinder is filled with air at atmospheric pressure, instead of at a lower pressure due to the attenuation consequent upon a spring-loaded suction valve. If this mechanical valve is arranged in the piston itself, as is done in some designs, the cylinder clearance volume can be appreciably reduced. The delivery valves are invariably automatic. A valve gear which would adapt itself to the varying point of delivery with different pressures would obviously be somewhat complex. In high pressure work the necessity for this refinement is rather doubtful.

Regarding the disposition of valves, these are usually arranged in the cover of low-pressure cylinders in order to reduce clearance as far as possible, thereby seriously detracting from the cooling surface. Suction valves in the piston are not without disadvantages, since at the end of the suction stroke the inertia of the valve tends to seat it too soon and the cylinder is not fully filled with air. In some cases this arrangement necessitates the suction air being drawn through the crank case. It is argued that this tends to keep the running parts cool, but this is a doubtful advantage when it is remembered that the low-pressure compression starts with air which has been already heated, and is probably charged with oil vapor.

Cooling Arrangements

The importance of keeping low the temperature within a compressor has al-

ready been emphasized. High temperatures are detrimental to the satisfactory operation of the machine, and in addition result in an increase in the work required. Special attention should be given to cooling arrangements. The best time to effect the cooling is during the actual compression, as this tends to keep the compression low near the isothermal. There are two methods of cooling during compression, namely, jacketing the cylinder and injecting water into the compressor. Regarding the latter, it is necessary to use fresh or distilled water, as any deposit would have harmful results on the cylinder bores, valves, etc.

Jacketing.—This method, although efficacious to a certain point, is only used in a few isolated cases, and the majority of machines are fitted with water jackets, which act in exactly the same way as the jackets on internal combustion engines. In high-speed machines, however, jacketing is of comparatively little value on account of the rate at which heat is generated, and as a result the compression law approximates to the adiabatic. The conditions are sometimes aggravated by a bad arrangement of valves, or thick liner flanges just where the cooling is most wanted, and these points, coupled with bad jacket circulation caused by air locks resulting from faulty design, render the cooling on some machines practically valueless as far as the work done, etc., is concerned. On the other hand, in machines designed with large clearance volumes (the low-pressure cylinder, of course, excepted) the cooling can be considerably improved by using a submerged pipe to conduct the air between the cylinder proper and the valves. This means that there is an increase in the cooling surface, and, moreover, the cooling here can be effected under the best conditions as to conductivity of the walls, etc. Not only is the air cooled during compression, but it also loses heat during re-expansion, so that the incoming air meets with comparatively cool clearance air, which condition assists in keeping low the initial compression temperature, and thereby reducing the maximum cylinder temperature.

Intercoolers.—In practice, however, as is impossible to deliver the air directly from one stage to the next in a cool condition, it becomes necessary to resort to intercooling. Between the stages the air is passed over a suitable cooling surface, which abstracts the remaining heat resulting from the compression in the lower stage, and the air enters the next stage cylinder in a cool state, the necessity for which has been previously explained. Intercoolers may consist of a simple coiled pipe, or may be of the multitubular type—similar to a surface condenser. The coiled pipe type takes up far more space per square foot of cooling surface than the multitubular variety, unless the construction of the machine permits of the coil being placed in the jacket round the cylinders, in which case a very compact arrangement is obtained at little cost.

The MacLean Publishing Company

LIMITED

(ESTABLISHED 1888)

JOHN BAYNE MACLEAN - - - - - President

H. T. HUNTER - - - - - Vice-President

H. V. TYRRELL - - - - - General Manager

PUBLISHERS OF

CANADIAN MACHINERY AND MANUFACTURING NEWS

A weekly newspaper devoted to the machinery and manufacturing interests.

PETER BAIN, M.E., Editor. B. G. NEWTON, Manager.
Associate Editors

A. G. WEBSTER J. M. WILSON J. H. RODGERS

Office of Publication, 143-153 University Avenue, Toronto, Ont.

Vol. XVII.

JUNE 28, 1917

No. 26

FIFTY YEARS OF CONFEDERATION

UNLESS all signs fail, printers' ink, during the present and following weeks will be lavished with a free hand for the purpose of marking the completion of fifty years of Confederation of the individual provinces of this Dominion of Canada, the consummation of which on July 1, 1867, has contributed so materially to her development and progress in almost every direction during the elapsed period. That we have progressed and are still doing so, goes without saying, although when we look back—far or not so very far, is it surprising that we have reached our present status? When account is taken of the grit and dogged perseverance of the men from the Motherland who in the early days "blazed the trail," and with their immediate successors in many instances, made roads, built bridges, harnessed waterpowers, dug canals, pinned ribbons of steel to the soil and stretched it across a whole continent, initiated agricultural and mineral development, established manufacturing, built ships and sailed them on our lakes, rivers and ocean coasts, we in these later years must perforce admit that ours is a goodly heritage, not only to be cherished and retained intact, but to be developed in manner worthy of those from whom it has been received.

In the half century that has elapsed, much to be nationally proud of has been accomplished and, as might be expected, there has been and still is in evidence, much to the contrary. We are at war, and have been so for nigh three long years, and just what the new half century on which we are about to enter has in store is largely matter of conjecture. At war, yes, and in diverse ways we have been made to realize it. We are prosperous, yes, but there is an uncanniness about it that bids us take heed. We are progressing, but is the overwhelming tendency in the right direction? We are confident to the point of self-sufficiency, but is it all justifiable? While we have played a part, and a most worthy one up to the present, comparatively our vision, and consequently our activities, have been "cramped, cabined and confined." In a word, we have been poor "mixers." A new era in every phase of our national life has already been ushered in as a result of this world-war and, as a consequence, the trend of our past half century of progress is likely to evidence many offshoots if we would not only maintain our present position, but occupy those others that meantime are offering, and the possession of which will unfold a myriad others.

The omens are in every respect favorable to not only

an unbroken continuance of the progress record of advancement of the past fifty years, but to its being stimulated in every sphere of our national life. Whether, in this war-time, we have done all we might or should have done, may be considered a moot point, everything considered. We have, however, not done badly, pharisaical even though the statement may seem; but much more is required and, needless to say, it is going to be forthcoming. We have a world-duty to perform, in the doing of which, our native or adopted country, as the case may be, will, as sure as night follows day, be a beneficiary. These are days when liberty—individual and national alike, are being strenuously assailed by tyranny of the foulest dye on the part of a sister nation, and to ensure that the part we have already played in the discomfiture of her tyranny may end in nothing short of her being completely squelched, if for no other reason, although there are others equally good, let the last fit man and the last, however hard-earned dollar, be spent.

In this issue features articles will be found covering specifically Canada's progress in a general sense, also that relating more particularly to the initiation and development of her machine tool and steel industries; supplemented by some detailed information covering her achievement in munitions manufacture, with conclusions drawn therefrom. In our July 5 issue the subjects of our railroad and general engineering progress will be given treatment relative to the elapsed period since Confederation.

MANNING CANADIAN BUILT MERCHANT SHIPS

RELATIVE to the shipbuilding and marine engineering activity now in evidence within our borders, and which is almost certain to extend well into the next decade, there is, in spite of the generally widespread appreciation of the fact that the meantime situation and outlook are so promising, apparently little, if any, thought being given to the matter of personnel wherewith to operate the large number of ships which will be produced on this continent in the coming months and years.

That it requires time—years indeed—to produce a marine engineer who can be entrusted with sole charge of a modern ship's machinery is evidenced by the requirements of the British Board of Trade in granting certificates, while the curricula prescribed is certainly such that few ordinary machine shop mechanics could at the moment approach with any degree of success. The necessity for additions to the supply of available marine engineers, however, is more than obvious to those most directly interested, and the certainty of an insistent demand in the near future for men capable of developing rapidly into high grade and efficient operators, is such that steps might very well be taken now to afford opportunity for the acquirement of the necessary knowledge.

No one will suggest for a moment that because a farm hand, who looked after agricultural machinery and had a mechanical bent, could run a lathe and do simple munitions operations, therefrom he became *ipso facto* a machinist. However, many machinists, tired of shop routine and repetitive operations, may well see in marine engineering an occupation for which they could quickly fit themselves so far as present general requirements are concerned, and which, when normal conditions return, would offer them possibilities for advancement and continuity of employment for two or three decades.

Present participation no doubt is accompanied by risks, but the latter have been taken by many others for the benefit of those yet to come, and the fact that present conditions have been brought about by the acceptance of these risks should act as a stimulant towards emulation.

INDUSTRIAL NOTABILITIES

LT.-COL. THE HON. FREDERIC NICHOLLS, president, Canadian General Electric Co., Toronto; president, Canada Foundry Co.; president, Canadian Allis-Chalmers, Ltd.; vice-president, Dominion Steel Corporation; president, Canadian Sunbeam Lamp Co.; president, Toronto & Hamilton Railway Co.; vice-president, Canadian Northern Quebec Railway Co.; vice-president, Dominion Coal Co.; vice-president, Dominion Iron & Steel Co.; vice-president, Electrical Development Co. of Ontario; vice-president, Sao Paulo Tramway, Light & Power Co.; vice-president, Toronto & Niagara Power Co.; vice-president, Toronto Power Co.; vice-president, Toronto Railway Co.; vice-president, Toronto & York Radial Railway Co.; director, British America Assurance Co.; director, Canadian Northern Railway Co.; director, Canadian Lake & Ocean Navigation Co.; director, Confederation Life Association; director, Imperial Rolling Stock Co.; director, Niagara, St. Catharines & Toronto Railway Co.; director, Toronto Electric Light Co.; director, Toronto Suburban Railway Co.; director, Toronto & Mimico Electric Railway; director, Western Assurance Co.; director, Great North Western Telegraph Co., was born in England, Nov. 23, 1856. He was educated at Stuttgart, Wurtemberg, Germany, and came to Canada, 1874.

The Senator has been prominently identified with the development of electricity, having organized the first company in Canada, the Toronto Incandescent Electric Light Co., which later adopted the underground system of electric distribution. He is a past-president, the National Electric Light Association of



LT.-COL. THE HON. FREDERIC NICHOLLS.

America, being the only Canadian who has held that position. This was in 1896. He is now an honorary member.

For seven years he was secretary of the Canadian Manufacturers' Association, founding its then official journal, and combining the dual role of editor and proprietor until 1893. He is Consul for Portugal; was president, the Toronto Press Club, 1890; president, the Athenaeum Club, 1893; is life member, Toronto Board of Trade; an honorary member, the Canadian Press Association; member of executive committee, the Canadian Manufacturers' Association; was made a J.P. and F.R.C.L. in 1911, and gazetted an Honorary Lieut.-Colonel, October, 1911. Appointment to the Senate came in January of this year.

During this war time the Senator occupies the following honorary positions: Member of the Executive Committee of the General Council of the Canadian Patriotic Fund; vice-president and chairman, Executive Committee, Toronto Branch Canadian Red Cross Society; president, Toronto Municipal Loan Association, a society formed to relieve distress.

He married Florence Graburn, daughter of Commander Graburn, in 1875 (deceased April, 1909).

His clubs are: Bankers' of America, N.Y.; York, Toronto, Toronto Hunt, Albany, Engineers', Ontario Jockey, Rosedale Golf, Toronto Golf, Scarborough Golf and Country, Hamilton Golf and Country, Royal Canadian Yacht, Mount Royal (Montreal); Rideau (Ottawa); Manitoba (Winnipeg); Mohawk (Schenectady, N.Y.). His recreations are hunting, fishing, motoring, yachting, golf. In politics he is Conservative, and in religious creed, Anglican.

His residences are 79 St. George St., Toronto, Ont., and "Parklands," Shanty Bay, Ont.

Photo, Courtesy British and Colonial Press.

SELECTED MARKET QUOTATIONS

Being a record of prices current on raw and finished material entering into the manufacture of mechanical and general engineering products.

PIG IRON.

Grey forge, Pittsburgh.....	\$47 95
Lake Superior, charcoal, Chicago.....	52 00
Standard low phos., Philadelphia.....	82 00
Bessemer, Pittsburgh.....	55 95
Basic, Valley furnace.....	50 00
Montreal Toronto	
Hamilton.....	
Victoria.....	

FINISHED IRON AND STEEL.

Per lb. to Large Buyers. Cents

Iron bars, base, Toronto.....	5 25
Steel bars, base, Toronto.....	5 50
Steel bars, 2 in. to 4 in. base.....	6 00
Steel bars, 4 in. and larger base.....	7 00
Iron bars, base, Montreal.....	5 25
Steel bars, base, Montreal.....	5 50
Reinforcing bars, base.....	5 25
Steel hoops.....	7 50
Band steel, No. 10 gauge.....	5 75
Chequered floor plate, 3-16 in.....	12 10
Chequered floor plate, 1/4 in.....	12 00
Staybolt iron.....	8 50
Bessemer mills.....	4 00
Steel bars, Pittsburgh.....	4 50
Tank plates, Pittsburgh.....	8 00
Structural shapes, Pittsburgh.....	4 50
Steel hoops, Pittsburgh.....	5 25

F.O.B. Toronto Warehouse

Steel bars.....	5 50
Small shapes.....	5 75

F.O.B. Chicago Warehouse

Steel bars.....	5 00
Structural shapes.....	5 00
Plates.....	8 50

FREIGHT RATES.

Pittsburgh to Following Points

	Per 100 lbs.	C.L.	L.C.L.
Montreal.....	23.1	31.5	
St. John, N.B.....	35.1	45.5	
Halifax.....	35.1	45.5	
Toronto.....	18.9	22.1	
Guelph.....	18.9	22.1	
London.....	18.9	22.1	
Windsor.....	18.9	22.1	
Winnipeg.....	64.9	85.1	

METALS.

	Montreal	Toronto
Lake copper.....	\$37 50	\$37 00
Electro copper.....	37 50	37 00
Castings, copper.....	36 50	36 00
Tin.....	63 00	66 00
Spelter.....	12 00	12 00
Lead.....	14 75	14 25
Antimony.....	25 00	26 00
Aluminum.....	70 00	68 00

Prices per 100 lbs.

PLATES.

	Montreal	Toronto
Plates, 1/4 to 1/2.....	\$10 00	\$11 00
Heads.....	10 30	11 30
Tank plates, 3-16 in.....	10 10	11 16

WROUGHT PIPE.

Effective May 14, 1917.

	Black	Galvanized
	Standard	Buttweld.
Size.	Per 100 feet	
1/4 in.....	\$ 4 50	\$ 6 00
1/2 in.....	4 96	7 00
3/4 in.....	4 96	7 00
1 in.....	6 29	7 86
1 1/4 in.....	7 94	10 06
1 1/2 in.....	11 73	14 88
2 in.....	15 87	20 13
2 1/2 in.....	18 98	24 06
3 in.....	25 53	32 88
3 1/2 in.....	40 95	51 77
4 in.....	53 55	67 70
4 1/2 in.....	66 24	83 26
5 in.....	78 48	98 65

Standard Lapweld.

2 in.....	28 49	34 97
2 1/2 in.....	42 71	52 94
3 in.....	55 85	69 28

3 1/2 in.....	68 08	86 02
4 in.....	80 66	101 90
4 1/2 in.....	93 98	118 70
5 in.....	109 50	138 40
6 in.....	142 10	179 50
7 in.....	185 60	232 05
8 L in.....	195 00	243 75
8 in.....	224 60	280 80
9 in.....	269 10	336 38
10 L in.....	249 60	312 00
10 in.....	321 40	401 70

Prices—Ontario, Quebec and Maritime Provinces.

WROUGHT NIPPLES.

4" and under, 50%.	
4 1/2" and larger, 45%.	
4" and under, running thread, 30%.	
Standard couplings, 4" and under, 40%.	
4 1/2" and larger, 20%.	

OLD MATERIAL.

Dealers' Buying Prices.

	Montreal	Toronto
Copper, light.....	\$22 00	\$22 00
Copper, crucible.....	25 00	27 00
Copper, heavy.....	26 00	26 50
Copper wire.....	26 00	26 50
No. 1 machine com-position.....	22 50	22 00
New brass clippings.....	18 00	19 00
No. 1 brass turnings.....	16 00	16 00
Heavy melting steel.....	20 00	17 00
Steel turnings.....	9 00	8 00
Shell turnings.....	12 00	12 00
Boiler plate.....	15 00	10 50
Axles, wrought iron.....	23 00	24 00
Rails.....	19 00	18 00
No. 1 machine cast iron.....	25 00	25 00
Malleable scrap.....	20 00	20 00
Pipe, wrought.....	17 00	9 00
Scrap zinc.....	8 00	9 50
Heavy lead.....	11 50	10 75
Tea lead.....	7 50	7 00
Aluminum.....	35 00	35 00

BOLTS, NUTS AND SCREWS.

	Per Cent.
Coach and lag screws.....	25
Stove bolts.....	55
Plate washers.....	net list
Machine bolts, 7-16 and over.....	net
Machine bolts, 3/8 and less.....	10
Blank bolts.....	net
Bolt ends.....	net
Elevator bolts.....	50 and 5
Machine screws, fl. and rd. hd., steel.....	27 1/2
Machine screws, o. and fl. hd., steel.....	10
Machine screws, fl. and rd. hd., brass.....	add 20
Machine screws, o. and fl. hd., brass.....	add 25
Nuts, square blank.....	add \$1 50
Nuts, square, tapped.....	add 1 75
Nuts, hex. blank.....	add 1 75
Nuts, hex. tapped.....	add 2 00
Copper rivets and burrs, list plus.....	30
Burrs only list plus.....	50
Iron rivets and burrs.....	17 1/2
Boiler rivets, base 3/4 in. and larger.....	\$7 10
Structural rivets, as above.....	7 00
Wood screws, flat, bright.....	.72 1/2
Wood screws, O. & R., bright.....	.67 1/2
Wood screws, flat, brass.....	.37 1/2
Wood screws, O. & R., brass.....	.32 1/2
Wood screws, flat, bronze.....	.27 1/2
Wood screws, O. & R., bronze.....	.25

MILLED PRODUCTS.

	Per cent.
Set screws.....	35
Sq. & Hex. Head Cap Screws.....	30
Rd. & Fil Head Cap Screws.....	10
Flat 7/8 But. Hd. Cap Screws.....	10
plus.....	10
Fin. & Semi-fin. nuts up to 1 in.....	25
Fin. and semi-fin. nuts, over 1 in., up to 1 1/2 in.....	30
Fin. and semi-fin. nuts, over 1 1/2 in., up to 2 in.....	10
Studs.....	20
Taper plus.....	40
Coupling bolts, plus.....	10
Planer head bolts, without fillet, list plus.....	10
Planer head bolts, with fillet, list plus 10 and.....	10
Planer head bolt nuts, same as finished nuts.....	10
Planer bolt washers.....	net
Hollow set screws.....	list plus 20
Collar screws.....	list plus 30, 10
Thumb screws.....	20
Thumb nuts.....	65
Patc bolts.....	add 40, 10
Cold pressed nuts to 1 1/2 in.....	add \$4.50
Cold pressed nuts over 1 1/2 in.....	add \$7.00

BILLETS.

	Per gross ton
Bessemer billets.....	\$100 00
Open-hearth billets.....	100 00
O.H. sheet bars.....	105 00
Forging billets.....	125 00
Wire rods.....	95 00

F.o.b. Pittsburgh.

NAILS AND SPIKES.

Wire nails.....	5 50	5 45
Cut nails.....	5 35	5 35
Miscellaneous wire nails.....	60%	
Spikes, 3/4 in. and larger.....	6 50	
Spikes, 1/4 and 5-16 in.....	7 00	

MISCELLANEOUS.

Solder, strictly.....	0 38
Solder, guaranteed.....	0 41
Babbitt metals.....	16 to 65
Soldering coppers, lb.....	0 53
Putty, 100-lb. drum.....	4 35
White lead, pure, cwt.....	19 00
Red dry lead, 100-lb. kegs, per cwt.....	13 87
Glue, English.....	0 38
Tarred slaters' paper, roll.....	0 95
Gasoline, per gal., bulk.....	0 31 1/4
Benzine, per gal., bulk.....	0 30 1/2
Pure turpentine, single bbls., gal.....	0 62 1/2
Linseed oil, raw, single, bbls.....	1 27
Linseed oil, boiled, single bbls.....	1 30
Plaster of Paris, per bbl.....	2 50
Plumbers' vacuum, per cwt.....	9 00
Packing, square braided.....	0 31
Packing, No. 1 Italian.....	0 10
Packing, No. 2 Italian.....	0 32
Lead wool, per lb.....	0 15
Pure Manila rope.....	0 37
Transmission rope, Manila.....	0 43
Drilling cables, Manila.....	0 39

POLISHED DRILL ROD.

Discount off list, Montreal and Toronto.....	25%
--	-----

CARBON DRILLS AND REAMERS.

	Per Cent.
S.S. drills, wire sizes up to 52.....	40
S.S. drills, wire sizes, No. 53 to 80.....	25
Standard drills to 1 1/2 in.....	40
Standard drills, over 1 1/2 in.....	15
3-fluted drills, plus.....	10
Jobbers' and letter sizes.....	40
Bit stock.....	40
Ratchet drills.....	15
S.S. drills for wood.....	40
Wood boring brace drills.....	25
Electricians' bits.....	30
Sockets.....	40

Sleeves.....	40
Taper pin reamers.....	20
Drills and countersinks.....	list plus 30
Bridge reamers.....	43
Centre reamers.....	10
Chucking reamers.....	10
Hand reamers.....	15

COLD ROLLED SHAFITING.

At mill..... list plus 40%

At warehouse..... list plus 50%

Discounts off new list. Warehouse price at Montreal and Toronto.

IRON PIPE FITTINGS.

Canadian malleable, A, add 10%; B and C, 10%; cast iron, 35%; standard bushings, 50%; headers, 60; flanged unions, 40; malleable bushings, 50; nipples, 55; malleable lipped unions, 50.
--

SHEETS.

	Montreal	Toronto
Sheets, Black, No. 28.....	\$10 00	\$10 00
Sheets, Black, No. 10.....	9 50	10 50
Canada plates, dull, 52 sheets.....	11 00	11 00
Canada plates, all bright.....	12 50	12 50
Apollo brand, 10 3/4 oz. galvanized.....	9 75	9 75
Queen's Head, 28 B, W.G.....	10 75	10 75
Fleur-de-Lis, 28 B.W.....	10 75	10 75
G.....	10 75	10 75
Gorbals Best, No. 28.....	10 25	10 25
Colborne Crown, No. 28.....	10 00	10 00
Premier, No. 28 U.S.....	10 90	11 70
Premier, 10 3/4 oz.....	11 10	12 00

PROOF COIL CHAIN.

B

1/4 in.....	\$10 75
5-16 in.....	10 40
3/8 in.....	10 25
7-16 in.....	10 00
1/2 in.....	9 90
9-16 in.....	9 90
5/8 in.....	9 75
3/4 in.....	9 50
1 inch.....	9 25
Extra for B.B. Chain.....	1 20
Extra for B.B.B. Chain.....	1 80

ELECTRIC WELD COIL CHAIN B.B.

1/4 in.....	\$15 50
3-16 in.....	11 70
1/2 in.....	8 40
5-16 in.....	7 40
3/8 in.....	6 35
7-16 in.....	6 35
1/2 in.....	6 35
5/8 in.....	6 35
3/4 in.....	6 35

FILES AND RASPS.

	Per Cent.
Great Western, American.....	55
Kearney & Foot, Arcade.....	55
J. Barton Smith, Eagle.....	55
McClelland, Globe.....	55
Whitman & Barnes.....	55
Black Diamond.....	45
Delta Files.....	40, 5
Nicholsen.....	45
Globe.....	55
Vulcan.....	55
Disston.....	55

COAL AND COKE.

Solvay Foundry Coke.....	\$10 90
Connellsville Foundry Coke.....	8 50
Steam Lump Coal.....	8 05
Best Slack.....	8 05

Net ton f.o.b. Toronto

BOILER TUBES.		
Size.	Seamless	Lap-welded
1 in.\$33 00
1 1/4 in. 36 00
1 1/2 in. 38 00	32 00
1 3/4 in. 38 00	32 00
2 in. 45 00	33 00
2 1/4 in. 48 00	35 00
2 1/2 in. 50 00	38 00
3 in. 58 00	45 00
3 1/4 in.	53 00
3 1/2 in. 70 00	55 00
4 in. 82 00	67 00

Prices per 100 feet, Montreal and Toronto.

OILS AND COMPOUNDS.	
Castor oil, per lb. 38
Royalite, per gal., bulk 16
Palacine 19
Machine oil, per gal. 26 1/2
Black oil, per gal. 13
Cylinder oil, Capital 45 1/2
Cylinder oil, Acme 36 1/2
Standard cutting compound, per lb. 6 15
Lard oil, per gal. 1 50
Union thread cutting oil antiseptic 68
Acme cutting oil, antiseptic 37 1/2
Imperial quenching oil 39 1/2
Petroleum fuel oil 11

BELTING—NO. 1 OAK TANNED.

Extra heavy, single and double30-5%
Standard 40%
Cut leather lacing, No.1 1 60
Leather in sides 1 35

TAPES.	
Chesterman Metallic, 50 ft.\$2 00
Luffin Metallic, 608, 50 ft. 2 00
Admiral Steel Tape, 50 ft. 2 75
Admiral Steel Tape, 100 ft. 4 45
Major Jun. Steel Tape, 50 ft. 3 50
Rival Steel Tape, 50 ft. 2 75
Rival Steel Tape, 100 ft. 4 45
Reliable Jun. Steel Tape, 50 ft. 3 50

WASTE.

White	Cents per lb.
XXX Extra 20
Peerless 20
Grand 19
Superior 19
N L C R 18
Atlas 18
X Empire 18
Ideal 17
X press 16

COLORED.

Lion 14 1/2
Standard 13
No. 1 13
Popular 11 1/4
Keen 10 1/4

WOOL PACKING.

Arrow 25
Axle 20
Anvil 15
Anchor 11

WASHED WIPERS.

Select White 12
Mixed colored 10
Dark colored 09

This list subject to trade discount for quantity.

RUBBER BELTING.

Standard 40%
Best grades 20%

ANODES.	
Nickel 50 to .54
Cobalt 1.75 to 2.00
Copper44 to .46
Tin49 to .56
Zinc23 to .25

Prices Per Lb.

COPPER SHEETS.

Montreal Toronto	
Bars, 1/2 to 2 in. 55 00 53 00
Plain sheets, 14 oz.
14x28 in., 14x60 in. 55 00 53 50
Copper sheet, tinned, 14x60, 14 oz. 60 00 54 25
Copper sheet, planished, 14x60 base. 64 00 60 00
Braziers', in sheets, 6x4 base 55 00 52 00

BRASS.

Brass rods, base 1/2 in to 1 in rd. 0 55
Brass sheets, 8 in. wide, 20 oz. 0 60
Brass tubing, seamless 0 57
Copper tubing, seamless 0 58

PLATING SUPPLIES.

Polishing wheels, felt. 2 50
Polishing wheels, bull-neck 1 35
Emery in kegs, American 06
Pumice, ground 04
Emery glue 15 to 20
Tripoli composition 04 to 06
Crocus composition 07 to 08
Emery composition 08 to 09
Rouge, silver 35 to 50
Rouge, powder 30 to 35

Prices Per Lb.

LEAD SHEETS.

Montreal Toronto	
Sheets, 3 lbs. sq. ft.\$18 00 \$18 00

Sheets, 3 1/2 lbs. sq. ft. 18 00	18 00
Sheets, 4 to 6 lbs. sq. ft. 17 50	17 50
Cut sheets, 1/2 c per lb. extra		
Cut sheets to size, 1 c per lb. extra.		

PLATING CHEMICALS.

Acid, boracic\$.15
Acid, hydrochloric05
Acid, hydrofluoric14 1/2
Acid, nitric10
Acid, sulphuric05
Ammonia, aqua08
Ammonium carbonate15
Ammonium chloride11
Ammonium hydrosulphuret40
Ammonium sulphate07
Arsenic, white12
Copper, carbonate, anhy.35
Copper, sulphate17
Cobalt sulphate70
Iron perchloride20
Lead acetate16
Nickel ammonium sulphate12
Nickel carbonate35
Nickel sulphate15
Potassium carbonate75
Potassium sulphide (substitute)20
Silver chloride (per oz.)65
Silver nitrate (per oz.)65
Sodium bisulphite10
Sodium carbonate crystals65
Sodium cyanide, 127-130%41
Sodium hydrate04
Sodium hyposulphite, per 100 lbs. 5.00
Sodium phosphate14
Tin chloride60
Zinc chloride60
Zinc sulphate09

Prices Per Lb. Unless Otherwise Stated.

The General Market Condition and Tendency

THE abnormal conditions in the steel industry in the States continue to be reflected in Canada. As predicted last week, prices of a number of steel products have advanced, including iron and steel bars, plates, shapes, black, blue-annealed and galvanized sheets, Canada plates, wire and wire products. Consumers, anxious to obtain steel, are paying fancy prices and are thus assisting materially in the upward movement. The shortage of steel is becoming more acute, causing considerable inconvenience to consumers who are getting behind in their work, owing to their inability to get material on time. The Canadian mills are booked up for at least six months and their output is largely being absorbed for war purposes, thus private consumers have to rely on United States mills for a considerable proportion of their requirements. Extraordinary prices are being paid for ship plates and shapes, and some mills are refusing business, so heavy is the demand. Domestic foundry pig-irons are still off the market and no prices are being quoted. In the States pig-iron prices are still climbing and the end is not in sight. The situation in the market is unsatisfactory owing to the heavy demand and scarcity of pig-iron. Prices of coke are also advancing and production does not increase, although the demand is heavier. There is no change in the coal situation, but the outlook is improving. Prices of non-ferrous metals are unchanged from last week. The markets are dull with business practically at a standstill, as both producers and consumers are awaiting developments pending definite action on the part of the American Government. The scrap metal market is also dull and featureless. Consumers are staying out of the market hoping for lower prices which does not appear probable, owing to the scarcity of scrap and tendency to higher prices for all metals. The situation in the machine tool market is much the same as last week. Prices continue to advance and deliveries are getting more backward.

Montreal, Que., June 25, 1917.—While production of shells continues without any apparent signs of abatement, interest at the present time seems to be

centered in the increasing activity in the ship building industry. In addition to the large number that are now actively engaged in the construction of various

sizes of wood and steel vessels, indications point to a considerable increase to the plants that are already established. Wooden vessels will continue to be the chief feature of this reconstructed industry as long as the heavy requirements of the steel trade absorb the bulk of the supply of steel; even when the war ceases, it is improbable that immediate relief will come owing to the fact that plate facilities will still be inadequate to meet the demand that will continue for a long time after.

Pig Iron

Existing conditions would seem to indicate that the apex of the market is far from being attained as price advances are now so regular that a week's passage without a rise is more of a surprise than a sharp advance. The supplying of sufficient pig iron to meet the requirements of the steel industry is becoming the problem of the day, and the situation is expected to take on a further serious aspect in the early future. The average advance on pig in the Pittsburgh during the week has been 2 1/2 dollars per ton, bessemer being now quoted at \$58.95 and basic at \$53.95 per ton. Relatively the same increase has taken place on other grades with the result that the composite price of pig iron is practically \$50 per ton. With Canadian producers virtually out of the market, dealers here refuse to quote on this grade of pig iron.

Steel

Prices continue to climb to dizzy heights. The activity has shown slight decrease during the past week but the early prospects are for still heavier buy-

ing. The American government is still endeavoring to establish order out of chaos regarding the point of fixing prices that will be paid for various classes of material. This condition tends to maintain the market in a somewhat unsettled state but apparently has had no effect upon the sharp advances that are constantly taking place. The requirements of the United States Government are gradually attaining larger proportions, creating a situation where it is practically impossible for domestic consumers to secure material. Where the pressure is the greatest and where it will continue to be, is in the increasing requirements of the ship building industry; this activity being an essential factor in the many problems confronting the steel situation at the present time. In view of the prevailing conditions all quotations on steel materials are of a nominal character, owing to the daily uncertainty of political and industrial developments. The American situation is reflected in further upward bounds in price quotations: The Pittsburgh price on forging billets has been advanced \$5 per ton, the current quotation being \$125 per ton. Rolling billets quoted at \$110 show an advance of \$10 per ton. The urgency of ship construction has placed such a pressure on the plate mills that price advances are now a thing to be looked for overnight; during the week \$20 per ton has been added to the American quotation on plates, the Pittsburgh base being now 9 cents per pound. Grooved and sheared steel skelp, which have been selling at 4 and 6 cents respectively, are now quoted at the nominal base of 8 cents per pound. Black and tin mill sheets, Pittsburgh, are now 9 cents, the week's advance corresponding to \$20 per ton. The American market has again experienced a \$10 per ton advance on wire products, the base on wire nails being now \$4.00 per hundred. The local market has developed no new features and general conditions remain unchanged; much difficulty is still experienced in the securing of material and the domestic demand for general commercial purposes is fast becoming a negative quality. Dealers here anticipate a further advance on plates and other steel products in the very near future.

Metals

No important developments have taken place to disturb the general tone of the metal situation. The entire market seems to be awaiting the outcome of what the United States Government intend to do regarding the placing of contracts and the regulation of prices. Copper is quiet and slightly easier. Tin is uncertain owing to lack of English information. Spelter is not active but retains its strength. Lead has shown a slight falling off. Antimony is quiet with weak undertone. Aluminum is firm and unchanged.

Copper.—The position of this metal is well maintained, but uncertainty surrounds the general situation. The un-

settled condition is the result of the delay on the part of the American Government regarding their requirements for their war program. Until this policy is definitely announced the market must necessarily be influenced by what might happen, and not by actual conditions. In the face of a quiet market New York quotations have shown a slight decline, $\frac{1}{2}c$ on lake and castings, and $\frac{1}{4}c$ on electro; the current quotations being $31\frac{1}{2}c$, $30\frac{1}{2}c$ and $32\frac{1}{2}c$ respectively. Local prices are firm and unchanged.

Tin.—While the market has fluctuated the situation at present is stronger than last week, due largely to the fact that information regarding conditions in England has not been forthcoming. The activities of submarines may have had something to do with this, but nothing definite has transpired to throw light on the actual cause. Conditions in the States are also tending to unsettle the market, as the attitude of the Government is of such a character as to retain the market in a state of nervousness. The situation this week shows an advance on the New York market of $1\frac{1}{2}c$, the quotation being $63\frac{1}{2}c$ per pound. Dealers here are asking $63c$, an advance over last week of $\frac{1}{2}c$ per lb.

Spelter.—Despite dullness the spelter market continues firm. The demand is very light for spot metal but the future positions are slightly more active. High production cost is the main factor in the steady strength of the market. A feature that may have some influence on future conditions is the efforts that are being put forth to find new uses for zinc, which in face of the high cost of other metals, may result in applying this particular metal to other useful purposes. Another decline of $\frac{1}{8}c$ has resulted on the New York market. The local situation remains quiet and quotations are unchanged at $12c$ per lb.

Lead.—Producers are taking a little more interest in the market and the situation this week has shown some relief over that of last week. In addition to this the output has materially increased and an easier undertone seem to be developing. A slight decline is noted in independent quotations on the New York market; the nominal outside price being now $12c$ per lb., a fall of $\frac{1}{4}c$ per lb. Activity on the local market has developed further strength and dealers are asking $14\frac{3}{4}c$, this being an advance of $\frac{3}{4}c$ per lb.

Antimony.—With the exception of futures, which are fairly active, the market remains quiet. Owing to the poor demand and the good supply the market has shown a weaker tendency with the New York market $\frac{1}{2}c$ easier than last week. Local dealers continue to quote $25c$.

Machine Tools and Supplies

The demand for machine tools continues quiet more especially as regards the requirements of munition plants. Inquiry for this class of equipment is now almost confined to the replacing of worn out machinery with a few addi-

tional tools here and there to permit of balancing up on the various operations to meet increased output. General equipment seems to be again in fair demand, this apparently being to the increased activity in marine circles and the possibility of additional accessories being required to equip the many boats on the shipbuilding program. With new companies being formed and old ones developing the prospects for increased business for general equipment for machine shops seems more than likely. This latter activity is more pronounced in the United States where the building of boats of every description has become one of the essential industries of the present day. Both as regards machine tools and also supplies, the condition of the market in raw and semi-finished materials is an influencing factor on price quotations, the importance of which is a feature that requires much consideration on the part of the user of machine tools.

Scrap

On a comparatively quiet market prices have remained unchanged with the exception of a few grades of steel and iron scrap. A factor that appears to be influencing conditions generally is the feeling that some sort of readjustment is inevitable, either through the developments pending in the States or as the outcome of trade conditions. This uncertainty has resulted in unsettling the market and dealers are cautious regarding the purchase and stocking of material, as definite delivery to consumers hinges on the action of the railroads and the cars available for transportation. Local changes are confined to some of the heavier scraps, heavy melting steel, is now \$20, wrought iron axles \$23, and machine cast iron \$25 per ton; advances on each being approximately \$1 per ton.

Toronto, Ont., June 26.—The outstanding feature in industrial circles is the increasing shortage and high cost of all raw materials. The situation confronting the manufacturer is getting more serious and almost impossible to adjust, as the circumstances responsible for this condition are beyond his control. The delay in getting deliveries of raw materials hinders production, while the steady rise in costs makes it difficult to fix selling prices. Indications point to conditions becoming worse, as the war demand is increasing and all other considerations have to take second place. In spite of these handicaps the volume of trade continues to increase, and the country was never more prosperous in all its history. Canada has become an important factor in the commercial world, and in this respect has made big strides during the past two years. The number of factories, variety of product and the official trade returns are ample evidence of this. Foundations have been laid for greater activity in the future.

Steel

Steel prices continue to advance in a

The A.R. Williams Machinery

— ■ Company

64-66 Front St. West,
Toronto



— ■ Limited

St. John, N.B., Winnipeg,
Vancouver

CANADA

For nearly forty years we have been intimately connected with the growth and development of the Machine Tool Industry in Canada. From our Head Office at Toronto we have reached out on either hand to the Pacific and Atlantic coasts with a chain of well-organized branches at Vancouver, B.C., Winnipeg, Man., and St. John, N.B.

During this period we have built up a connection with the leading and most up-to-date Machinery Manufacturers on this continent. Below we list a few of the most prominent of our agencies.

The W. F. & John Barnes Co., Rockford, Ill.
The Consolidated Press Co., Hastings, Mich.
The Davis Boring Tool Co., St. Louis, Mo.
Hendey Machine Co., Torrington, Conn.
Wilworth & Newman, Grand Rapids, Mich.
Harrifin Co., Chicago, Ill.
Taylor & Fenn, Hartford, Conn.
Beaudry & Co., Boston, Mass.
Fay & Scott Co., Dexter, Maine.
Diamond Machine Co., Providence, R.I.
Geometric Tool Co., New Haven, Conn.
Francis Reed Co., Worcester, Mass.
The Burke Machine Co., Conneaut, Ohio.
Bary Compressor Co., Erie, Pa.
Foote Burt Co., Cleveland.
Baker Bros., Toledo, Ohio.
Cincinnati Iron & Steel Co., Cincinnati, Ohio.
Smith & Mills Co., Cincinnati, Ohio.
National Automatic Tool Co., Richmond, Ind.
Warner & Swasey Co., Cleveland, Ohio.

Williams Tool Co., Erie, Pa.
Hisey Wolf Machine Co., Cincinnati, Ohio.
Fosdick Machine Tool Co., Cincinnati, Ohio.
Le Blond Machine Tool Co., Cincinnati, Ohio.
High Speed Hammer Co., Rochester, N.Y.
Bridgeford Machine Tool Co., Rochester, N.Y.
Diamond Saw & Stamping Works, Buffalo, N.Y.
American Pulley Co., Philadelphia.
Hyatt Roller Bearing Co., Newark, N.J.
Gould & Eberhardt, Newark, N.J.
Landis Machine Co., Waynesboro, Pa.
Landis Tool Co., Waynesboro, Pa.
Blanchard Machine Co., Cambridge, Mass.
National Electric Welder Co., Warren, O.
Leland Gifford Co., Worcester, Mass.
Buffalo Foundry & Machine Co., Buffalo, N.Y.
(Bell Hammers)
Cleveland Automatic Tool Co., Cleveland.
Woodward & Powell (Planers), Worcester, Mass.

If it's Machinery write "Williams"

The A. R. Williams Machinery Co., Limited

64-66 Front Street West, TORONTO, ONT.

If any advertisement interests you, tear it out now and place with letters to be answered.

CANADA'S LEADING
MACHINERY
HOUSE

ST. JOHN, N. B.
WINNIPEG
VANCOUVER

The A.R. WILLIAMS Company Limited

64-66 Front Street W Toronto, Canada

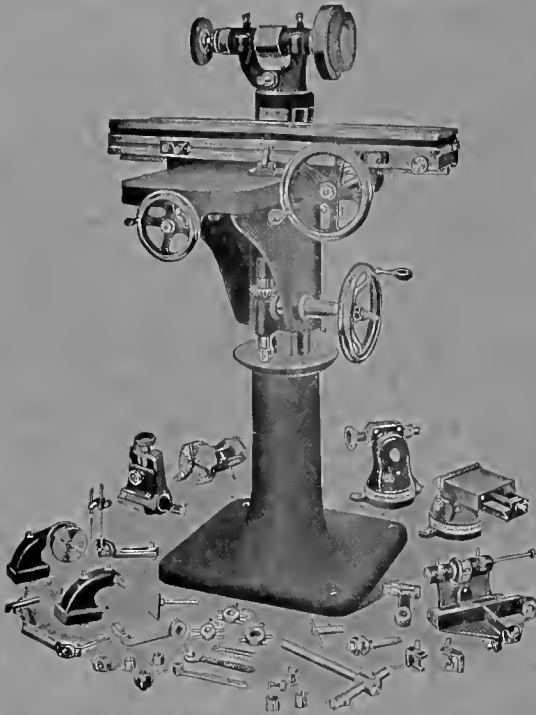

Speed, Accuracy and Versatility

put a new low mark on tool room grinding work. The greater the variety of the work the more the need for a

Greenfield

It is for that exact purpose - variety - that this machine was developed. There are no troublesome changes and adjustments necessary on the Attachments. All are complete in themselves, perfectly adapted for the work for which they are designed, and 100 per cent. convenient in operation.

Be sure to investigate this grinder before buying.

Greenfield Machine Company

Greenfield, Mass., U. S. A.

UNITS of EFFICIENCY

STRENGTH, endurance, power and flexibility are all embodied in the Taylor & Fenn system of interchangeable drilling machine heads. With this system a wide range of usefulness is covered. Heads are arranged for independent lever feed, simultaneous lever feed, automatic power feed, high speed (spindle driven), and reverse motion for special tapping operations.

Any type drilling head may be used, with any other on the same base, only a few seconds being required to place or replace them.

The combination of gears and silent chain (see illustration) furnishes a positive drive with abundance of power, and eliminates costly and troublesome belts and the care and adjustment of idler pulleys.

Our catalogue gives full information. May we send it?

The Taylor & Fenn Co., HARTFORD, CONN., U.S.A.

Manufacturers of Light Sensitive Drilling Machines, Spring Foot Presses, and the Whitney Water Tool Grinder

Foreign Agents:

- The A. R. Williams Machinery Co., Ltd., Toronto, Ontario, Canada
- Burton, Griffiths & Co., Ltd., London, E.C., England
- R. S. Stolvis & Zonen, Ltd., Rotterdam, Holland
- Fenwick Freres & Co., Paris, France
- G. Schinz, Petrograd, Russia
- H. P. Gregory & Co., Sydney, N.S.W., Australia

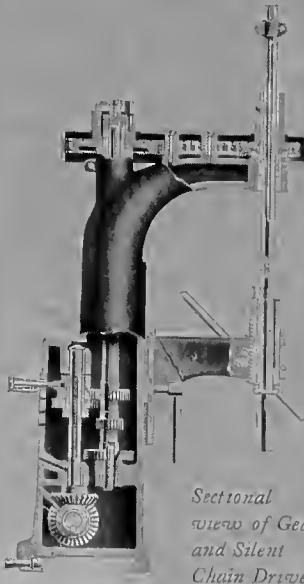

Sectional views of Gear and Silent Chain Drive

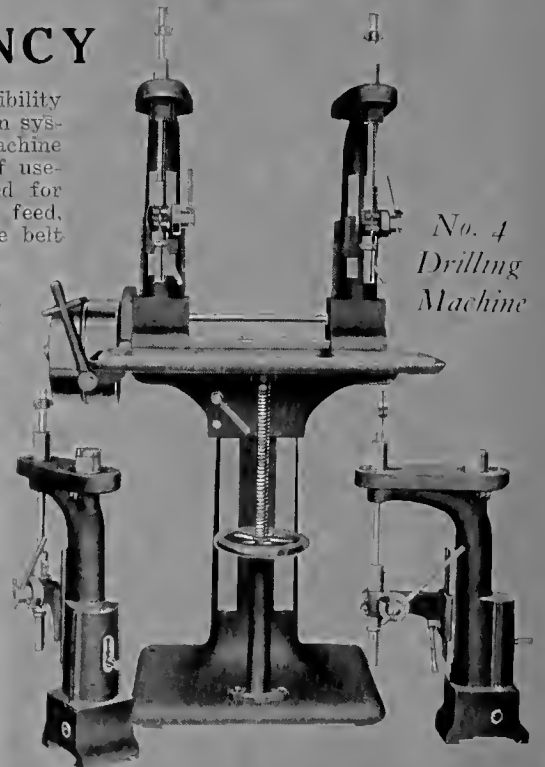

CANADA'S LEADING
MACHINERY
HOUSE

ST. JOHN, N. B.
WINNIPEG
VANCOUVER

The A. R. WILLIAMS Machinery Company Limited

64-66 Front Street W Toronto, Canada

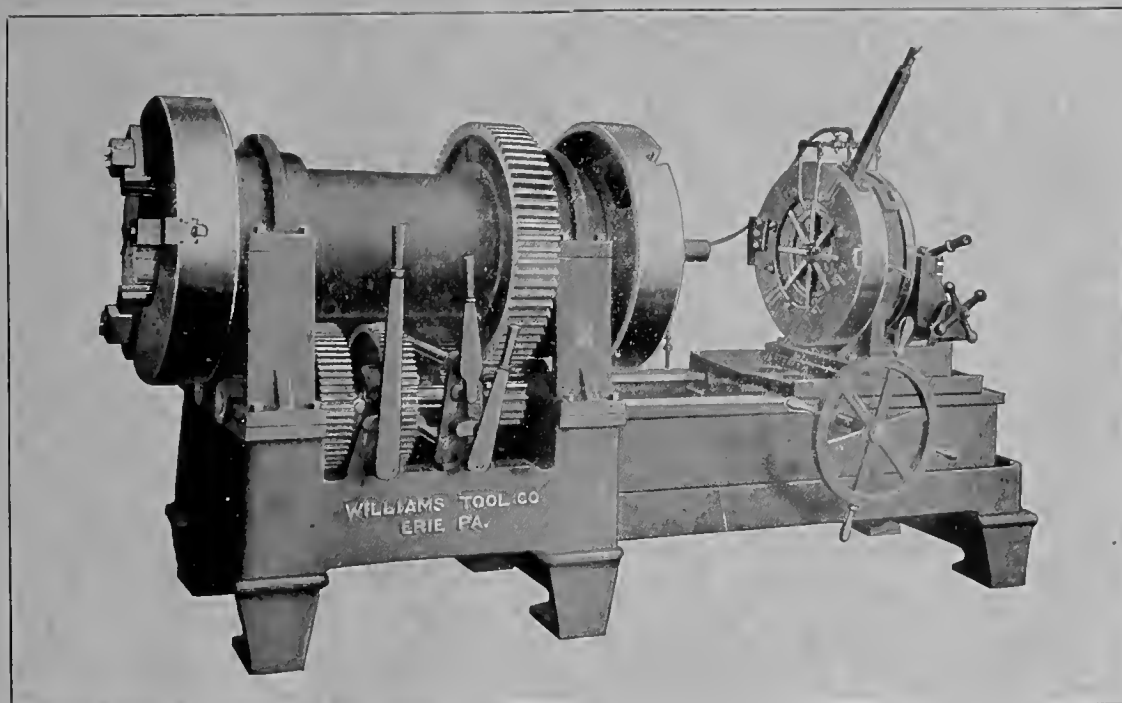

Williams Lead in Exhibition and in Actual Practice

The range of a machine such as Williams Pipe Threader will make it a valuable asset to any shop. Any size from $\frac{1}{4}$ " to 18" dia. there is a Williams to take care of it. Each machine includes 8 to 10 consecutive sizes. By carrying off the highest honors at the Panama Exposition these machines established themselves as distinctly the leaders in their line. In Europe, Canada and United States these machines have been favorably installed and have proven their value.

Get into communication with us. We will give you our co-operation and the value of our experience.

Williams Tool Company
Erie, Pa., U.S.A.

The A. R. Williams Machinery Company, Limited, Toronto, Agents

If interested, tear out this print out now and place with letters to be answered.

CANADA'S LEADING
MACHINERY
HOUSE

ST. JOHN, N. B.
WINNIPEG
VANCOUVER

The A·R·WILLIAMS Company Limited

64-66 Front Street W Toronto, Canada

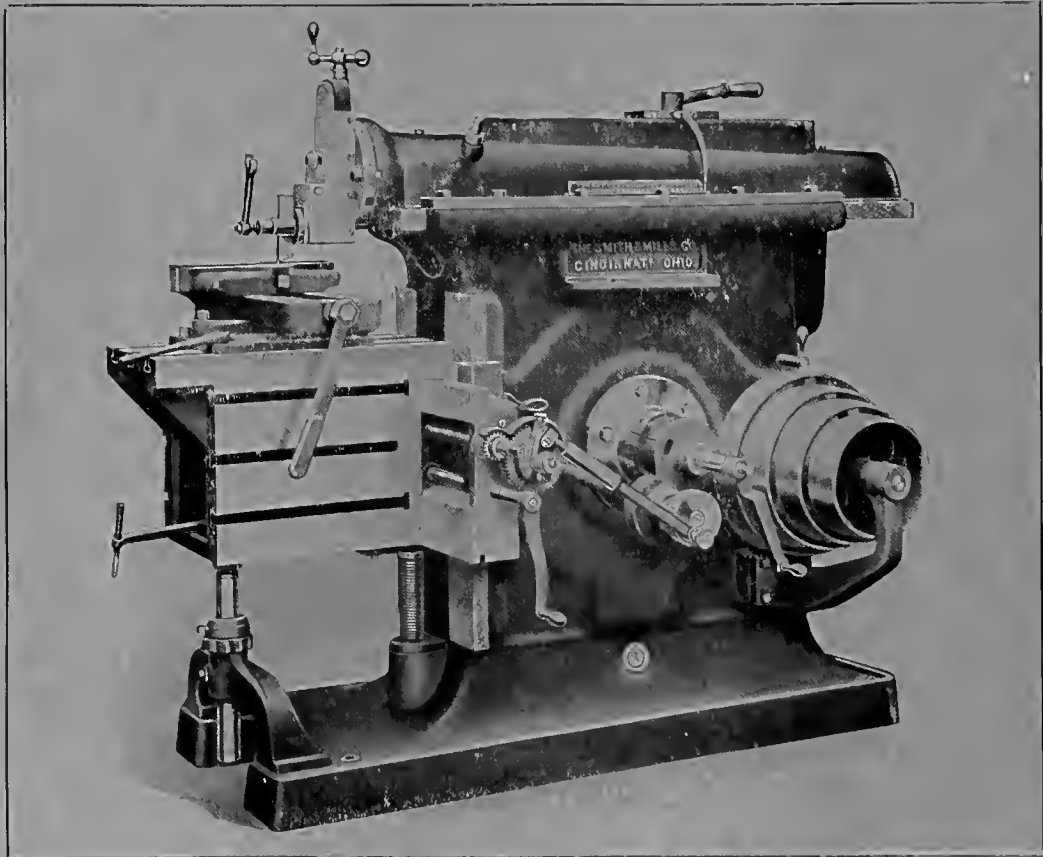

SHAPERS exclusively and exclusive shapers. Through concentrating all our energies, our experience, and benefiting by outside criticisms, we are capable of presenting for your inspection a machine whose quality is unequalled. It is exclusive. Others think so. We would be delighted to send you full particulars also.

Smith & Mills Company

Cincinnati

Ohio

U.S.A.

CANADA'S LEADING
MACHINERY
HOUSE

ST. JOHN, N. B.
WINNIPEG
VANCOUVER

The A·R·WILLIAMS Machinery Company Limited

64-66 Front Street W Toronto, Canada

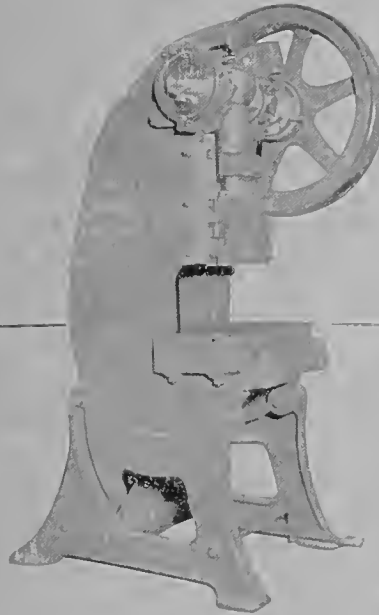
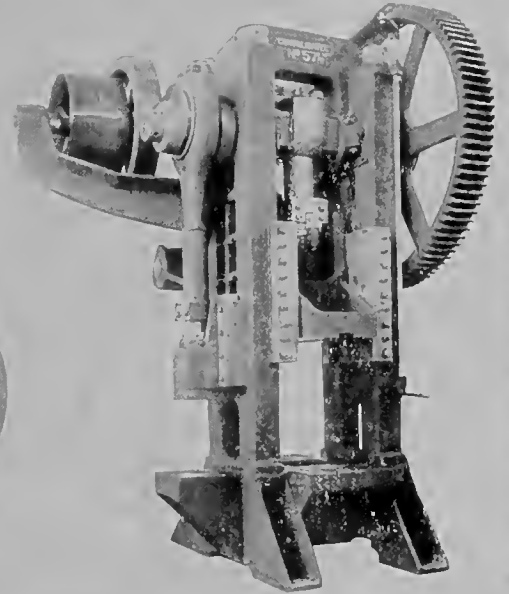
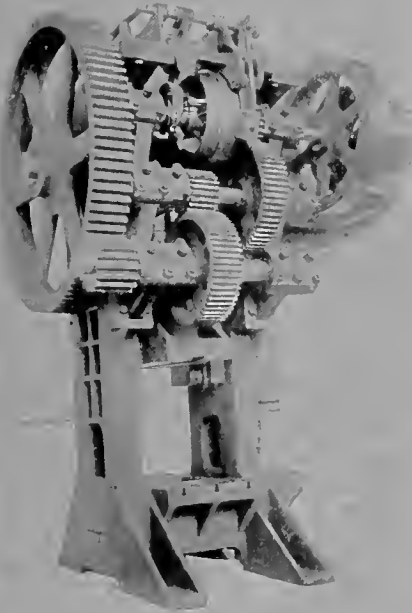

A "Consolidated" will solve pressing needs

For marking Fuses, Fuse Bodies, for Blanking, Cupping and Drawing Cartridge Cases. These among any use to which a press may be subject is included in the Consolidated line.

"Consolidated" have a reputation of the highest standard to maintain in their machine. Exclusive features, including three locking points in the hubs of all fly wheels, thus giving 20% more production.

Our catalogue will explain in detail. Write for it.

Williams' carry a complete line in stock in Toronto.

THE CONSOLIDATED PRESS & TOOL CO., Hastings, Michigan, U.S.A.

If any advertisement interests you, tear it out now and place with letters to be answered.

CANADA'S LEADING
MACHINERY
HOUSE

ST. JOHN, N. B.
WINNIPEG
VANCOUVER

The A.R. WILLIAMS Company Limited

MACHINERY

64-66 Front Street W Toronto, Canada

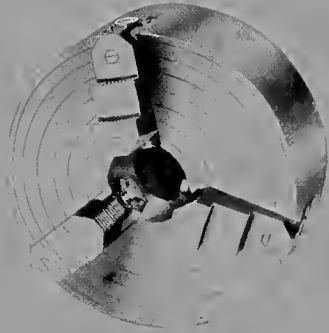

Air Operated Three-Jaw
Universal Chuck



Air Operated Two-Jaw
Universal Chuck

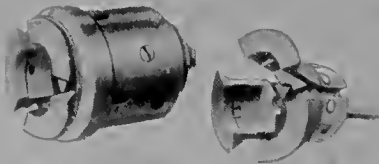

Master Hinge Collet Chuck

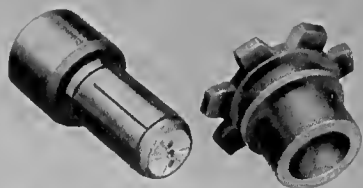

Air Operated Expanding Mandrel

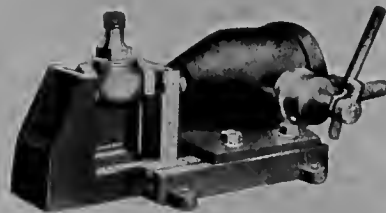

Air Operated Vise

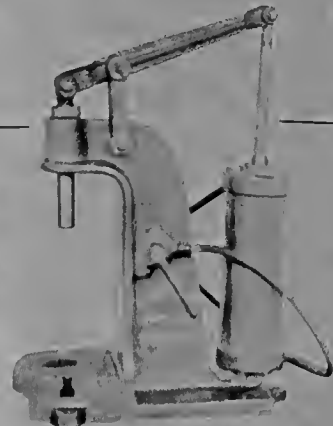

Air Operated Arbor Press

AERO CHUCKS

- Air Operated Chucks
- Air Operated Expanding Mandrels
- Air Operated Jigs and Clamping Devices
- Air Operated Countershafts
- Air Operated Vises
- Air Operated Arbor Presses
- Air Operated Chucks for Fuse Parts
- Air Operated Chucks for All Size
Shells as Large as 9.2 inch.

We can furnish anything in air operated chucking and clamping fixtures. Send us blue prints of your work and we will submit designs.

Send for our 1916 catalog.

Hannifin Mfg. Co.

CHICAGO, ILL.
U.S.A.

CANADA'S LEADING
MACHINERY
HOUSE

ST. JOHN, N. B.
WINNIPEG
VANCOUVER

The A. R. WILLIAMS Machinery Company Limited

64-66 Front Street W Toronto, Canada

WHY CISCO IS THE LATHE WITH THE PULL

Designed and constructed upon absolutely uniform and correct lines; eliminating all unnecessary features, levers, intricate parts; with broad bearings, generous dimensions and each part fitting into the other as though implanted there; with a rigid semi-steel bed, heavy headstock, broad carriage with the strength just where it is needed (on the upward pull), double supported apron and a tailstock that with only half its regular bearing will support any strain; with the change gears and apron gears all steel and the powerful worm drive, which by its arrangement not only gives power, but is the most economical apron built to-day, it is a Lathe which will

SURVIVE ANY TEST.

Ask a Cisco user how many dollars he has spent for repairs.
Ask a Cisco buyer what is the simplest lathe to run in his shop.
Ask a Cisco lathe runner what the machine will show in accurate turning or boring.

Then be real obstinate, and, because "Dad" or "Uncle Zeke" used another make, spite yourself by not

BUYING A CISCO.

No, we believe you are too broad-minded to do that.

CISCOS FOR CANADA

Sold in Canada by

**The A. R. Williams Machinery
Company, Limited**

The Most Progressive Agents
in Canada

Made in 14", 16", 18", 24" by

The Cincinnati Iron & Steel Co.
CINCINNATI, U.S.A.

MAKERS OF

THE LATHE WITH THE PULL

If any advertisement interests you, tear it out now and place with letters to be answered.

THE A.R. WILLIAMS MACHINERY COMPANY LIMITED
TORONTO CANADA

Our Perfect Tool Room Equipment. Ask Your Foreman

Westinghouse Motor

LeBlond Tool and Cutter Grinder

No. 2 Hendey Universal Miller

Hyatt Roller Bearing

American Gas Oven Furnace

Gould & Eberhardt 16 Shaper

Hendey 14 x 6 Lathe

Brown & Sharpe Milling Cutters

Racine Hack Saw

La Salle Automatic Surface Grinder

20" Barnes Drill

American Steel Pulley

Mention this paper when writing advertisers. It will identify the proposition about which you require information.

remarkable manner, hardly a day passes without some change in the price situation. A number of price changes predicted last week are now in effect, and all indications point to further advances in the near future. The local situation in the steel trade reflects conditions in the market in the United States. The advances this week include bars, plates, shapes, black and galvanized sheets, wire and wire products. The situation in the plate market is unprecedented, and extraordinary prices are being paid for ship material, some quotations being as high as 16c at Pittsburgh. Inquiries for thousands of tons of plates have again been turned down on account of the sold-up condition of the mills. The mills report that the output is practically normal, and they have all they can do for a year ahead without booking any additional tonnage. The new quotations for ¼-in. plate and larger is \$11, heads \$11.30, and tank plate \$11.10. These prices, however, are largely nominal, as it is practically impossible to name a firm quotation. Iron bars are now quoted at 5.25c, steel bars 5.50c, and small shapes 5.75c base. Band steel is now 5.75c, chequered floor plate 3-16 in., 12.10c, and staybolt iron, 8.50c base. The new price on smooth steel wire, No. 0-9 gauge, is \$6.50 per 100 lbs. base, while wire products have advanced in proportion, that is 25c per 100 lbs.

The position of the private consumer is becoming more difficult owing to the steady increase in war demand for steel. The American Government requirements of steel, which are the dominating factor in the trade in the U. S. at the present time, are affecting the situation in Canada to such an extent that material is very difficult to obtain in addition to the extraordinary high prices. Canadian consumers have now to rely upon American mills to a greater extent than in normal times, as domestic mills are filled up with war business. On this account the situation will get worse as the American Government requirements get heavier.

Prices of black and galvanized sheets have again advanced. Black No. 28 gauge is now \$10, and No. 10 gauge \$10.50. Premier No. 28 is \$11.70 and 10% ozs. \$12. Canada plates dull, \$11, and bright, \$12.50 per 100 lbs. These prices are higher, due to advances in the U. S. market. The American Government requirements continue to receive practically the entire attention of sheet manufacturers who are not making full deliveries even to old customers. Few sheet makers now feel in a position to make any sales because of the heavy calls for material by the Government.

Steel prices in the U. S. continue to climb with the average of leading products now about \$115 a ton, as compared with \$98 a ton two weeks ago. The demand for steel is acute, as many customers are months behind in their work owing to delays in getting deliveries of steel ordered long ago. The Government has not as yet definitely fixed prices on iron and steel products, and the situation is becoming more difficult to handle, as the cost of material is rapidly increasing. Consumers are so anxious to get steel that they are paying almost any price,

and the market is more or less out of control. Iron and steel bars and shapes have advanced, as have also open-hearth billets.

Pig Iron

The market continues very strong with prices still climbing. Domestic foundry irons are still off the market, and consequently no prices are obtainable. The situation is acute owing to the steadily increasing demand, scarcity of iron and high prices. Prices are climbing so steadily that it is impossible to place much confidence in quotations more than a day old. Lake Superior charcoal iron has reached a maximum of \$62 delivered Chicago. Pittsburgh dealers are quoting \$60 Valley for basic iron, while low phosphorous is quoted at \$82.50 Pittsburgh. Connellsville furnace coke is quoted at \$12.50 ovens, with no improvement in production.

Scrap

The scrap market continues dull at unchanged quotations. Consumers appear to be waiting for lower prices, but in this they may be disappointed, as indications point to higher levels, particularly in the event of a buying movement developing. There is at the present time a decided scarcity of practically all old materials, which is naturally tending to keep prices up. Then, again, the increase in price of all new metals enhances the value of scrap.

Machine Tools

The sale during the week of some machine tools for making "gaines" has brightened up the munitions end of the business somewhat, but the demand for tools for ordinary purposes continues to be the chief feature in the trade. The renewed activity in the machine tool trade in the States is beginning to affect the Canadian market. Prices are still advancing, and deliveries are more backward, while it is highly probable that considerable trouble may be experienced in importing machine tools from the U. S. unless they are for munitions purposes. Government work is occupying the attention of the machine tool trade in the States to the exclusion of almost all other business. Canadian machine tool builders continue well employed.

Supplies

Prices of all machine shop and mill supplies continue very firm, with an upward tendency in some cases, particularly in iron, steel or brass goods. Castor oil is up 5c, being now quoted at 40c per lb. Lard oil has advanced 5c to \$1.50 a gallon. Linseed oil is weaker, and prices have declined to \$1.27 for raw and \$1.30 for boiled oil. Turpentine is also lower, and is now 62½c per gallon.

Metals

The metal markets in New York have relapsed into a quiet condition, due to the uncertainty regarding the American Government requirements and probable prices. Under the circumstances producers and consumers are not inclined to do business preferring to wait developments. This situation is reflected locally and prices generally are unchanged, but holding steady. News of an interesting

development in the metal situation comes to hand to the effect that some members of the zinc industry are engaged in trying to discover new uses for zinc. With the scarcity of some other metals and the comparative cheapness of zinc their efforts may very likely be successful. Lead may also come under examination, as the extremely high price of this metal has resulted in investigations being started to discover whether there are not some uses for which a cheaper substitute can be found.

Copper.—No new features have developed in the copper situation, the market being inactive, pending a decision regarding the price of American Government purchases. In the absence of actual business the nominal market quotations are unchanged. The strong feature of the market lies in the fact that the Allies copper contracts expire this month, and it is expected that a call will be made for a further supply. This, however, is somewhat offset by probable price concessions. Lake and electrolytic copper are quoted at 37c and castings at 36c per pound.

Tin.—With the market reacting in London, the local situation has become somewhat unsettled. Prices, however, are in the meantime unchanged, although a lower tendency is discernible. The tin market in New York continues quiet, with buyers uncertain as to what course to pursue pending a more definite information as to the intention of the Government in regard to prices. Local tin prices are unchanged and nominal at 66c per pound.

Spelter.—There is little change in the spelter situation. The market remains quiet, and is not even sustained by the high cost of production. It is understood that negotiations are nearing completion at Washington by which the Government will purchase its next spelter requirements. Local price unchanged at 12c per pound.

Lead.—The American Government has agreed to purchase 8,000 tons of lead between now and August 1 at a price of 8c St. Louis. This decision has cleared the air somewhat, but the quantity is less than had been estimated. As a consequence the market is slightly easier, but quotations are unchanged. The "Trust" is quoting 11c, but independents are higher at 11.75c to 12c New York. Lead is quoted locally at 11½c per lb.

Antimony.—The demand has fallen off during the last few days, though there is a fair amount of business going through for future delivery. Spot antimony is dull. Local quotations unchanged at 26c per pound.

Aluminum.—The situation is unchanged and demand is light. The market is weaker, but quotations are unchanged at 68c per pound.

Sydney, N.S., June 23.—Fusion of the Provincial Workmen's Association and the United Mine Works of Nova Scotia is now an accomplished fact under the new title of the Amalgamated Mine Workers of Nova Scotia. The new officers represent an equal number from the two

amalgamating unions. With the absorption of the Provincial Workmen's Association into the new union there passes out of provincial affairs one of the oldest, if not the oldest, trade union in Canada. It has always been a purely provincial organization, as its name implies, and its record is in line with the best traditions of trades unionism. The passing of this old-established labor combination is a sign of the times, as it marks the passing of the conservative and extremely self-reliant and independent miner that was typical of the earlier days of the coal industry in Nova Scotia, and is a sign of the increasing influence and dominance of men of more advanced views. The fusion of the two unions is an indirect result of the war, and the ability of the more advanced labor advocates to make their influence felt because of the reluctance of the more conservative men to adopt a provocative attitude during the critical days of war times.

Weekly pays have been substituted for fortnightly pays at the Nova Scotian collieries since May 1. The result has been a lesser disturbance of working conditions on the days following the pay-day, but it is yet too soon to state what the cumulative effect will be. Some lessening of the disorganization after pay-days is also due to the great stringency of the enforcement of the prohibition laws that have supposedly been in operation in Nova Scotia for many years past. It is an undoubted fact that the Sydney district and the mining towns are "drier" than they have ever been before. The distinction is still comparative, however, and absolute prohibition has not yet been brought about.

Coal production is being steadily maintained. No great progress has been made in lifting the coal storage banks at Glace Bay. Bunker business continues very brisk.

The Dominion Iron & Steel Co. has undertaken to roll a limited tonnage of rails for the Canadian Government Railways. These will be the first rails that have been rolled for several years at its plant.

Pittsburgh, Pa., June 23.—The steel market is still more difficult to locate, as there is but little tonnage moving in the open market and each transaction is a law to itself. In a general way the market seems to be quotable about as follows, all Pittsburgh:

Tank plates	8.00—9.00
Blue annealed sheets ..	7.50—8.50
Black sheets	8.00—9.00
Steel bars	4.50—4.75
Refined iron bars.....	4.75
Shapes	4.50—4.75
Wire nails	4.00

Generally speaking the deliveries would be in from three to six months. What makes the market so difficult to quote is that there is no regular forward delivery market. That has dropped out of sight, by common consent. The large buyers would not care to do business for the indefinite deliveries the large mills could make. Some do not see that they will need material after the country is

fully in the war and others have a great deal of tonnage due them on which deliveries are very uncertain by reason of the precedence given to Government orders placed or to be placed. It is probable that in exceptional cases some mills are taking care of regular customers at prices less than those quoted as the market, but on the other hand they often refuse to quote at all, and if they quote for export it is generally at still higher prices.

Decreases in Requirements

At a time when the large mills are filled with business equal to six to ten months' production and are in line to receive much more from the Government in addition, the trend is towards a much smaller commercial consumption of steel. Large building operations are not being undertaken, except in rare instances. The fabricated steel jobs taken by members of the Bridge Builders' and Structural Society represented only 56½ per cent. of a month's capacity, rated at about 180,000 tons, and this month will show much smaller bookings. The railroads are practically wholly out of the market. The only commodity they might buy is rails, and they are given no opportunity. The rails they receive this year are costing them \$28 for Bessemer and \$30 for open-hearth, while the two \$5 advances last year make the present nominal prices \$38 and \$40. The railroads can secure about \$45 for old rails for remelting, say \$50 for re-rollers, and up to \$80 for relayers. Naturally the railroads would buy rails if they could.

In the automobile trade the slowing down is more noticeable each week, but it is not uniform among different makers. Some, like Ford, have heavier requirements than expected, but in general the automobile factories are specifying less against their contracts than formerly, and a much greater slowing down is to be expected in the next two months.

U.S. Government Requirements

The U.S. Government has distributed orders for 81,000 tons of shell steel rounds for making 3-inch shrapnel and high explosive shell, at 3.75c., a price considerably lower than prices the Entente Allies have been paying for a twelve-month or thereabouts, some of the steel of which is still to be delivered. There is no further news as to the plans considered for the Government to buy 100,000 freight cars or more, together with some locomotives,

to lease to the railroads for the duration of the war. A considerable tonnage of sheets has been distributed by the committee of three sheet manufacturers but prices, if already fixed, have not been announced. Nothing has been heard lately of the hangar program, which will involve a large tonnage of steel, as eventually the number will run well into the thousands.

Coke

Coke shipments from the Connellsville region have continued to prove insufficient for the blast furnaces tributary, on account of car shortage. Following representations made by blast furnace interests the Commission on Car Service at Washington promptly issued an order to the railroads under date of June 19, that the supplies to the region be increased 80 per cent. Next day the railway officials concerned held a meeting in Pittsburgh and expressed the opinion that they would be able to comply. The majority of coke producers are dubious, while the blast furnaces are hopeful. Spot furnace coke remains at about \$12 per net ton at ovens, and on account of the uncertainties, operators will not make contracts for second half.

Pig Iron

Pig iron continues to rise, but hardly in as spectacular fashion as in May or early this month. Striking an average, the advance now seems to be at the rate of about \$2 per ton per week. Minimum prices at valley furnaces (95 cents higher delivered Pittsburgh), are \$50 for basic, \$53 for malleable and foundry, and \$55 for Bessemer, but slightly higher prices are being asked. It is beyond question that pig iron is scarce relative to the requirements of the steel works and foundries, and the common view among producers is that there will be further advances. Inasmuch, however, as nearly all the iron to be produced this year has been sold, and the chief market is for the first half of next year, there are other things to be considered, whether consumers will require as much iron nine months hence and whether production may not be greater, provided there is a better coke supply and furnaces now being built are completed. The by-product coke plants have had no serious difficulty and the Steel Corporation expects to have a part of its very large by-product plant at Clairton, near Pittsburgh, completed and in operation next September.

Industrial and Construction News

ENGINEERING

Windsor, Ont.—The Lake Erie Coal Co. propose to rebuild their plant which was recently damaged.

Vancouver, B.C.—It is understood that the aerodromes for the Lulu Island aviation field will be constructed by the contracting firm headed by Col. Lowe.

Toronto, Ont.—The Russell Motor Co. will build an addition to their plant on

Dufferin street. The extension includes a machine shop, lunch and wash rooms, etc.

Hamilton, Ont.—The Provincial Government are building a power house at the Asylum here. Tenders are now being called for the reinforced concrete work.

Matheson, Ont.—Quite a large portion of the machinery for the new mill at the Croesus Mine, in Munro Township, has

Daylight Saving

with a

GEOMETRIC

That is what it amounts to. Time is not the only thing saved, either. Geometrics are a saving proposition all around.

This Geometric Collapsing Tap is specially arranged for deep tapping in Projectile Caps.

All classes of thread tapping above $\frac{3}{4}$ -inch diameter are taken care of by Geometric Collapsing Taps.

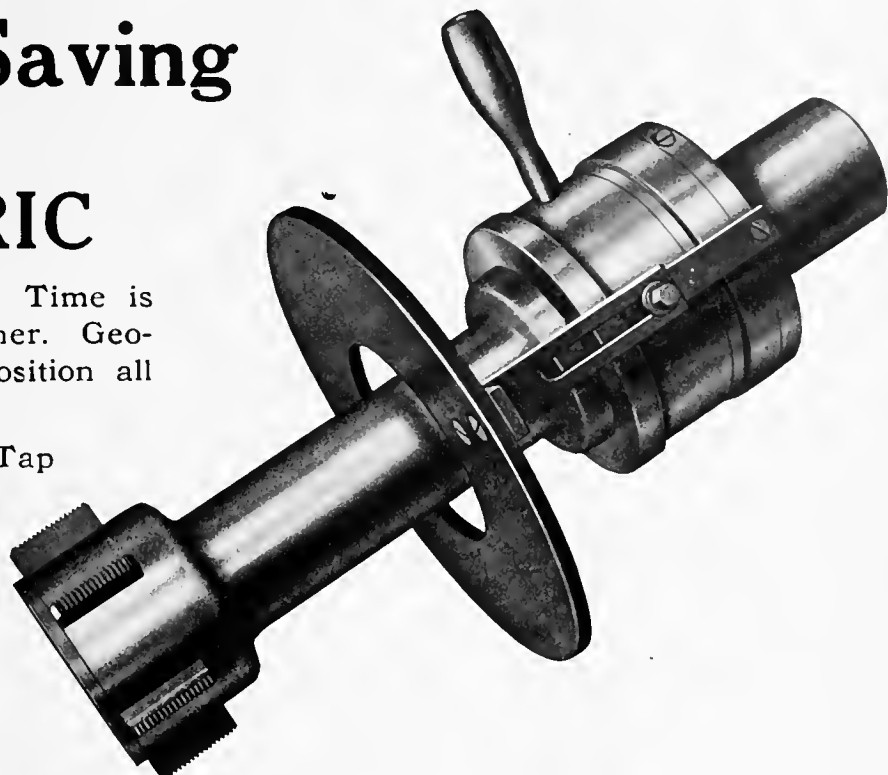

Twenty-five years of specializing in Screw Thread Cutting Tools has made the name GEOMETRIC stand for all that could be asked in Screw Thread Production.

When it is an outside thread, Geometric Die Heads cut every style from 1-16-inch size up to greatest required diameter.

A U.S. Navy Yard is using this $4\frac{1}{2}$ -inch size Style "D" Geometric Die Head. United States Navy Yards accept no second quality.

Do your Screw Machines and Turret Lathes swing Geometrics?

You have as much right to Geometric benefits as any other manufacturer.

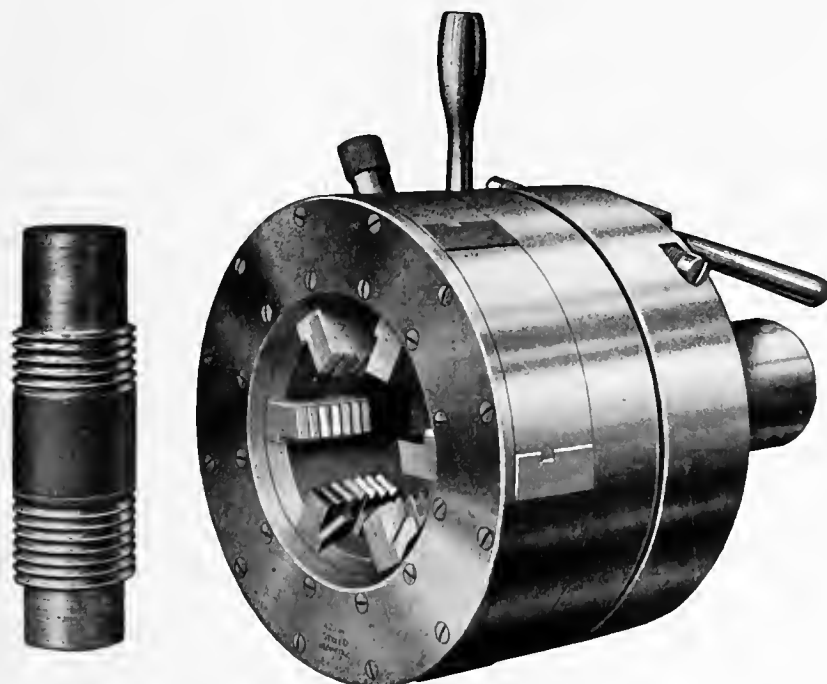

The Geometric Tool Company, New Haven, Conn., U.S.A.

Canadian Agents:

Williams & Wilson, Ltd., Montreal. The A. R. Williams Machinery Co., Ltd., Toronto, Winnipeg, St. John, N. B.

If any advertisement interests you, tear it out now and place with letters to be answered.

The "Delta" makes the stock fly



We have made exhaustive working tests of the Delta File against other files and it has shown increased output in given time and much greater durability of cutting edge.

The Delta is the only line of files from 3 to 24 inches—made absolutely of crucible steel.

Make the acquaintance of the Delta service now through a trial order. You have nothing to lose, for your money goes back promptly if not convinced that Delta Files are all that is claimed for them.

Write your dealer.



DELTA FILE WORKS

PHILADELPHIA, PA. U.S.A.

CANADIAN AGENTS:

H. S. Howland, Sons & Co., Toronto
 Starke, Seybold, Montreal
 Wm. Stairs, Son & Morrow, Halifax
 Merrick-Anderson Co., Winnipeg
 ALL LEADING JOBBERS



now been installed, and it is expected the mill will be in operation before fall.

Brantford, Ont.—Fire on Sunday damaged part of Gould, Shapley & Muir's factory. The fire occurred in a frame building adjoining the main plant, and was prevented from spreading by the sprinkler system.

Fort William, Ont.—Crib work and foundation work on the new Eastern Terminal Elevator Co. new plant at Current river, Port Arthur, is now well under way, according to Superintendent R. D. Morgan, it is hoped that the elevator will be ready for operation by January 1st of next year. The tank foundations of the Saskatchewan Co-operative Elevator Co.'s buildings are being constructed.

Toronto, Ont.—The Polson Iron Works, Ltd., have had plans prepared for a new boiler shop, 250 ft. by 90 ft. wide. It will be of steel and concrete construction. The equipment will be the latest type, and will include an overhead electric travelling crane. The present boiler shop will be overhauled and re-fitted for an extension to the machine shop and engineering department. A new gantry crane, 65 ft. wide by 50 ft. high, of 10 tons capacity, is being erected on the east side of the dock. Other extensions include a lumber storage and auxiliary store house.

Port Coquitlam, B.C.—An agreement has been entered into between A. F. Bernstein and the Corporation of Port Coquitlam, B.C., to provide for the erection of an electrical smelting plant here consisting of four 25-ton per day units. The plant is also to be provided with a rolling mill, having an output of 75 tons per day. The company must produce 15,000 tons of pig iron per annum. The plant is designed to treat the magnetite ores of B.C. and construction will commence shortly. A by-law will be submitted to the electors shortly to authorize assistance by way of a bonus of \$200,000, payable upon completion of the plant. Manso, Ramsay & Co., of Vancouver, B.C., are the consulting engineers to whom communications may be addressed.

MUNICIPAL

Peterboro, Ont.—The City Council have decided to purchase a combination chemical and hose wagon from the American La France Co., at \$8,800.

Hamilton, Ont.—City Engineer E. R. Gray is preparing specifications for the additional steam and electrical equipment which will be installed at the pumping station. The cost is estimated at \$127,000.

Oshawa, Ont.—The Town Council have given the first and second reading on a by-law to authorize an expenditure of \$38,000 on a filtration plant. The John Ver Mehr Co., of Toronto, have already been awarded a provisional contract.

Hamilton, Ont.—The Board of Control have refused to accept any of the tenders submitted for a building to house the new civic weigh scales and its operator at a cost of \$3,500, and instead will

erect a chalet for the weigh scales, leaving the house for the operator in abeyance until next year.

Toronto, Ont.—A by-law will be submitted to the City Council to authorize an issue of bonds for \$4,000,000 for harbor improvement work, and \$720,000 for hydro-electric extensions. In the latter amount is included \$350,000 for a sub-station and fixtures for the supplies of power to the steel plant on Ashbridges' Bay.

Chatham, Ont.—A movement has been inaugurated to instal a cold storage plant in connection with local Hydro station, making it possible for the committee to purchase butter, eggs, fish, and other perishable commodities in large quantities. The Public Utilities Commission is considering the matter, and it is possible that a recommendation will be made to carry out the proposal.

Hull, Que.—At the meeting of the City Council recently, the aldermen displayed much interest in a letter from Russell Blackburn, of the Ottawa and Hull Power and Manufacturing Co., asking for a fixed assessment on a plant it is proposed to construct at a cost of \$400,000 on a dam adjoining the E. B. Eddy Co.'s mills. Nothing definite was done in regard to the application, but it was evident that the aldermen are anxious to have the plant erected.

GENERAL

London, Ont.—The London & Petroleum Barrel Co., will extend their plant here.

Toronto, Ont.—Willard's Chocolate, Ltd., will build an extension to their factory.

Hamilton, Ont.—The Canadian Shovel & Tool Co., will shortly commence the construction of an extension to their plant, to cost about \$35,000.

Hamilton, Ont.—The Canadian Cotton Co., will build an addition to their factory at a cost of \$60,000.

Hamilton, Ont.—Work on the new addition to the factory of the Proctor-Gamble Co., contemplated some months ago, will be begun immediately. A permit for the addition has been issued, the cost being estimated at \$8,000.

Lanark, Ont.—The Clyde Woollen Mills, operated by the Boyd-Caldwell Co., here, were completely destroyed by fire last Thursday night. The loss is estimated at \$150,000. W. C. Caldwell is the principal owner.

Sorel, Que.—Fire on June 19, practically wiped out the whole waterfront doing damage estimated at \$250,000. The principal losses will be incurred by the Canada Steamship Lines, the Metropolitan Insurance Co., the Sorel Newspaper Co., the Bell Telephone Co., and the Dominion Government. Most of the damage was covered by insurance.

MARINE

Sault Ste. Marie, Ont.—A down-bound boat on June 21 reported passing through a field of ice 30 miles in length on Lake Superior.

Aikenhead's New Chuck

Don't Throw Away Broken Tang Drills

Perhaps you are about to discard some taper shank drills because the tangs are broken off—DON'T DO IT—they are worth their weight in gold. You can use them just as they are with a

Wahlstrom Automatic Chuck

One chuck holds drills from 1/16" to 1 1/4"

and you won't have to take time from your production to repair them.

Tool changes are made in two seconds—Just grasp the shell of the chuck with one hand and put in or remove the tool with the other—no collets—no lost time, for the spindle never stops. The jaws grip NOT BY THE TANG, BUT ON THE SIDE OF THE TAPER—there's no chance for slippage—a Wahlstrom won't even mar the shanks.

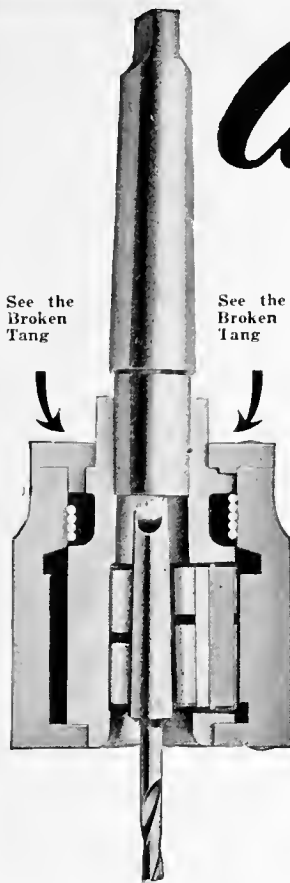

AIKENHEAD HARDWARE LIMITED

17, 19, 21 Temperance Street - Toronto, Canada

Aikenhead's MOTORS

Self-Starting Induction Motors



Continuous Service. Single Phase.
For 110 Volts. 25 Cycles.

H.P.	Speed Synch R.P.M.	Frame No.	Code	Shipping Weight
1.50	1500	A-00	Sar	25
1.30	1500	A-0	Sen	26
1.15	1500	A-1	Sul	26
1.10	1500	A-2	Tic	38
1.6	1500	A-3	Tup	45
1.3	1500	A-4	Cure	62
1.2	1500	A-4		

For 220 volt add "LY" to code.

Prices for any Voltage upon request.

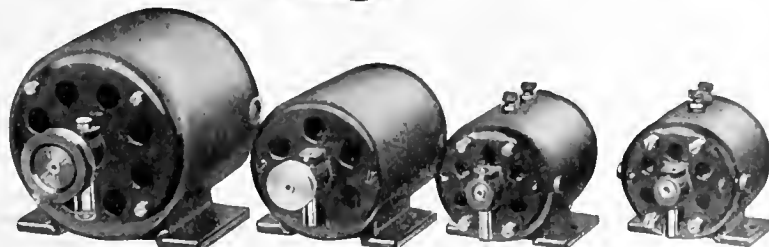

Aikenhead Hardware, Ltd.

17, 19, 21 Temperance St.
TORONTO - - CANADA

If any advertisement interests you, tear it out now and place with letters to be answered.

GAUGES

DIES, TOOLS AND REPAIRS
OXY-ACETYLENE WELDING

WORTH ENGINEERING CO.

163 Spadina Ave., Toronto, Ont.

Phone Adel. 3734

B. H. AYLSWORTH A. E. HACKWORTH

Oxy-Acetylene Welding

We can give the best of service in all kinds of welding repair jobs. We have successfully repaired the most difficult jobs. Our work is high-class and our prices moderate.

Send us your work or write us regard ne. it.

TORONTO WELDING CO.

26 Pearl St., TORONTO

ON PAGE 150

You'll find a host
of Opportunities.

TURN TO IT!

METAL STAMPINGS

We are manufacturers of stamped parts for other manufacturers.

We do any kind of sheet metal stamping that you require. Our improved presses and plating plant enable us to produce the finest quality of work in a surprisingly short time.

We can finish steel stamping in Nickel, Brass or Copper.

Send us a sample order.

W. H. BANFIELD & SONS

372 Pape Avenue, Toronto, Can.

Vancouver, B.C.—The wooden vessels which the Western Canada Shipyards, Ltd., will build will be 2,800 gross tons, 280 feet long and 44 feet beam.

Draft Marked Up on Lakes. — The draft for the American lock at the Soo has been marked up two inches, and at the Canadian lock one inch. The draft for boats loading between Lake Superior and Ohio ports has been increased two inches, and boats running between Lake Michigan and Ohio ports can load four inches deeper.

Buoys in Operation Again.—It is announced that the submarine bell at Whitefish Point light station, Lake Superior, which was reported not ringing, was restored to commission June 17, and that North Point gas and bell buoy No. 1, Lake Huron, which was reported not burning, was re-lighted June 16.

New Westminster, B.C.—Preliminary to building four of the wooden steamers ordered by the Imperial Munitions Board, the New Westminster Construction & Engineering Co. is clearing the site for its shipyard on Poplar Island. The vessels will be 250 feet long by 44 feet beam, and will have a capacity of over a million and a half feet of lumber.

New Westminster, B.C.—A request for exemption from taxation for eight or ten years in consideration of the establishment of a wooden shipbuilding plant at Queensborough was laid before the City Council in committee recently by Messrs. Van Syckle and Macdonald, of Vancouver. The cost of the plant they propose to establish will be from \$50,000 to \$100,000.

Fort William, Ont.—The work of excavation has been started at the plant of the Great Lakes Dredging Co., on island number two, for the ways for the keel blocks of the first wooden ship to be built in Fort William. As soon as it is possible to get this done, the work of construction on the first of the wooden ships will be started.

Vancouver, B.C.—The little steamer Eva Maria, which piled up on a reef near Helmcken Island recently may be a total loss. Information received, states that the vessel is heeled over on the starboard side 140 degrees, practically capsized. The hull is badly twisted and the vessel is resting on the bilge and guard. All the seams have opened up and the boiler has shifted.

Vancouver, B.C.—Word has been received locally to the effect that T. A. Russell and R. E. Chisholm, of the Imperial Munitions Board of Toronto, will be here shortly with authority to let contracts for machinery for the vessels now being built for the board in British Columbia. It is understood that they are to make an inspection of the plants in British Columbia and if in their opinion the plants are able to take on the work they have authority to let contracts for a certain portion. The committee appointed to represent the British Columbia Metal Trades Association is keeping in close touch with R. P. Butchart and Capt. Troup in connection with the building of engines and auxiliary machinery of the ships to be built here.

CONTRACTS

Montreal, P.Q.—The Harbor Commission have awarded contract to the Cement-Gun Co., Toronto, for one G. L. N. type cement-gun.

Montreal, Que.—The Imperial Tobacco Co. have let a number of contracts in connection with the addition to the factory at St. Henri. The total cost will be about \$100,000.

Sudbury, Ont.—The Town Council have awarded a contract for a steel standpipe to the Chicago Bridge & Iron Works, Bridgeburg, Ont., for \$31,000.

Toronto, Ont.—McGregor & McIntyre have been awarded the structural steel contract for the new boiler shop for the Polson Iron Works.

INCORPORATIONS

Slater & Barton, Ltd., have been incorporated at Ottawa with a capital of \$1,000,000. This concern is an amalgamation of the Allith Manufacturing Co. and the Acme Stamp & Tool Co., of Hamilton, Ont.

Electric Steel & Engineering, Ltd., has been incorporated at Ottawa with a capital of \$2,000,000 to manufacture steel and carry on the business of engineers and smelters etc., at Welland, Ont. The incorporators are J. S. Lovell, C. D. Magee and W. Bain all of Toronto.

Calgary Petrol Ltd., has been incorporated with a capital of \$250,000 at Ottawa to manufacture and operate methods and apparatus for treating natural gas, petroleum etc., at Calgary, Alta. The incorporators are H. E. Foster, A. W. Dingman and C. W. Coale all of Calgary.

WOODWORKING

Vancouver, B.C.—The Dewar Shingle Co., contemplate building a shingle factory.

Owen Sound, Ont.—The Keenan Wood-ware Co. will shortly commence building their factory here.

Port Arthur, Ont.—The Pigeon River Lumber Co., will start up their saw mill shortly, for the season.

Vancouver, B.C.—The Cameron Lumber Co. mills, near Selkirk Water, B.C., together with the larger part of the machine shop, were destroyed by fire with a loss of \$100,000.

TENDERS

Strathroy, Ont.—Town Council will call for tenders about July 1 for water-works improvements, costing \$10,000. Engineers, Kerry & Chase, Toronto.

Outremont, Que.—Tenders will be received up to July 18, for the construction of an incinerator. Specifications may be obtained from J. A. Duchastel, city engineer, City Hall.

Point Claire, Que.—Tenders will be received until June 27, for constructing filtration plant and installing pumps for the town council. Plans and specifications at office of the engineers, W. S. & R. S. Lea, 809 New Birks Bldg., Montreal.

Kingston, Ont.—Tenders will be received until July 16 for the reconstruction of part of the cribwork wharves at the entrance to the Dry Dock, at Kingston, Ont. Plans and forms of contract can be seen and specifications and forms of tender obtained at the Department of Public Works, Ottawa, the offices of the District Engineer, Equity Building, Toronto, Ont., and on application to the postmaster, at Kingston, Ont.

RAILWAYS—BRIDGES

Toronto, Ont.—Approval of the agreement between the city and the C.P.R. for the construction of a reinforced concrete structure to carry the railway tracks across the reservoir ravine to replace the present track bridge, was given by the Board of Control when submitted by Works Commissioner Harris a few days ago.

ELECTRICAL

St. Thomas, Ont.—The Town Council contemplate purchasing electrical equipment.

TRADE GOSSIP

Scarcity of Tungsten.—The demand for tungsten is heavier than the market can supply conveniently and prices are firm at current quotations, which range between \$20 and \$22 New York for high-grade material.

The Federal Engineering Co. have vacated their premises at Spadina avenue and have moved to more commodious and convenient quarters at 172 John street, Toronto. All friends attending the C. A. S. E. convention in July are requested to call and inspect the new offices.

P. & O. Amalgamate With Union S.S. Co.—The Peninsular & Oriental Steam Navigation Co. has amalgamated with the Union Steamship Co. of New Zealand, opening the Canadian-Australian line from Vancouver to Honolulu and Sydney, it was announced at Vancouver recently.

The Eastern Car Co. has opened an office in New York City, and Messrs. Gordon M. Graham and Joseph Eaton, of New Glasgow, N.S., will look after the interests of the firm there. Their duties will be largely in connection with the export of material used in the manufacture of cars for foreign orders.

Australian Scheme to Develop Industries.—The Melbourne Age says that the Federal Ministers are considering a scheme for providing for the expenditure, over a term of years, of at least £10,000,000, on the establishment of certain factories under joint private and Government supervision. The scheme includes the creation of a national industrial department in close contact with the Commonwealth banks.

Exports Mostly to Britain.—The Minister of Finance stated recently in the House of Commons, Ottawa, that the total merchandise exported to foreign countries from August 1, 1914, to March

WM. MUIR & CO., LIMITED
Manchester, England.
Machine Tool Makers.
Specialties: Patent Puncher Slotting Machines, Milling Machines, Boring Machines.
Agents: Messrs. Peacock Bros., 68 Beaver Hall Hill, Montreal.
Send for catalogue.

JOHN STIRK & SONS, Limited
HALIFAX, ENG.
MACHINE TOOLS
Agents—The A. R. Williams Mcy. Co., Ltd.
Toronto, Winnipeg, Vancouver, St. John. N.B.

BERTRAMS LIMITED
Engineers
Sciennes, EDINBURGH
PAPER MILL MACHINERY
and
MACHINE TOOLS FOR IRON WORKERS
Catalogues offered to Purchasers.

WIRE SPRINGS
OF ALL KINDS
Machine Springs, Valve Springs, Automobile Cushion Springs, etc., of a quality that defies competition. Tell us your requirements. Send sample or specification for price.
JAMES STEELE, LIMITED
GUELPH, ONTARIO

Quality is Highest—Not the Price
Dickow's Guaranteed 10-Inch Universal Index Centers
You save from \$50 to \$125 on first cost, and many times that because of their simple construction and great ease of operation. They embody the maximum of accuracy, simplicity and durability.

Get the Original—Beware of imitators
Sold by all dealers. Write to-day for particulars
Fred. C. Dickow, 35 So. Desplaines St., Chicago, Ill., U.S.A.

Oil Tempered Steel Springs
—for every purpose and the best for each use.
Special styles of all kind to order.
THE CLEVELAND WIRE SPRING COMPANY
Cleveland, Ohio
U.S.A.

BOLTS
Our large stock of Machine Bolts, Rivets and Washers assures quickly filled orders and prompt shipment. One quality only—The Best.
Send a trial order.
LONDON BOLT & NUT WORKS
London Ontario

Special Machinery
MADE TO ORDER
Mill Machinery, Engine Work
Grey Iron and Brass Castings
TRY US FOR GENERAL REPAIRS
ALEXANDER FLECK, LIMITED
(Vulcan Iron Works) OTTAWA, ONT.

We Know
you are anxious to buy
Canadian Made
goods.
The Imperial

Chuck
is manufactured by
Ker & Goodwin
Brantford, Canada

PATENT ATTORNEYS

BABCOCK & SONS

ESTAB. 1877

PATENTS-TRADE MARK-DESIGNS
 IN ALL COUNTRIES

Book "Patent Protection"—Free. Master of Patent Laws, Formerly Patent Office Examiner.

 99 St. James St., - Montreal, Que.
 Branches: Ottawa, Washington.

RESEARCH BUREAU

REPORTS BY EXPERTS ON SCIENTIFIC, TECHNICAL AND INDUSTRIAL DEVELOPMENT.

SPECIAL RESEARCHES ARRANGED.

PATENTS, TRADE MARKS, ETC.

 HANBURY A. BUDDEN CABLE ADDRESS
 712 DRUMMOND BLDG., MONTREAL "BREVET"

PATENTS

Fetherstonhaugh & Co.,
 Patent Solicitors, Head Office,
 Royal Bank Bldg., Toronto,
 Ottawa Office, 5 Elgin St.
 Send for our Plain Practical
 Pointers. Copy of National
 Progress, in which our patents
 are advertised, mailed free.

PATENTS PROMPTLY SECURED

In all countries. Ask for our Investor's Adviser, which will be sent free.

MARION & MARION 364 University St.
 Merchants Bank Building, corner
 St. Catherine St., MONTREAL, Phone Up. 6474
 and Washington, D.C., U.S.A.

MORTON MANUFACTURING CO.

PORTABLE PLANERS
 DRAW CUT SHAPERS
 SPECIAL DRAW CUT R.R. SHAPERS
 FINISHED MACHINE KEYS
 STATIONARY & PORTABLE KEY WAY CUTTERS
 SPECIAL LOCOMOTIVE CYLINDER PLANERS

OFFICE AND WORKS: MUSKEGON HEIGHTS U.S.A.

MAPLE LEAF

STITCHED COTTON DUCK

BELTING

DOMINION BELTING CO. LTD.

HAMILTON CANADA

31, 1917, amounted to \$2,287,557,612. Of this amount \$1,380,253,928 went to Great Britain and \$634,741,601 to the United States. Merchandise to the value of \$2,675 was loaded for Germany prior to the outbreak of war. The Government, however, has no record of shipments to Hamburg, Germany.

The Storey Pump & Equipment Co., Toronto, have supplied two 3 in. four stage Morris turbine pumps to the Ontario Hydro-Electric Commission for the Chippewa Creek development.

Dominion Bridge May Build Ships.—Dominion Bridge officials are reticent as to future plans of the company in regard to the shipbuilding business, but there is a rumor that the company is about to enter that field. General Manager Duggan has had several visits to Halifax and Sydney of late, where he has conferred with the Beardmore and English interests. It is reported from the East that tentative arrangements have been made with one of the big steel companies for the erection of mills for the rolling of steel plates.

Government Ready to Operate Mines.—Replying to a question in the House of Commons, Ottawa, on June 21, about the Western coal mine situation, Hon. T. W. Crothers, Minister of Labor, stated that the mines would be in operation within a few days under the guidance of the Government, unless the operators and miners got together. The only point in dispute was the penalty clause, which the operators insisted upon putting into the contract. Both sides were willing to accept the scale of wages proposed by the Government special commissioner, R. F. Green, M.P.

Steel Price Inquiry.—The United States Government inquiry into steel making costs, in the opinion of manufacturers may develop facts likely to reduce the bickering reported from Washington. It will show, for one thing, that one company's expense in making plates, steel bars, structural forms, etc., is by no means the same as the expenses of another concern. It is pointed out that while the Steel Corporation might show good profits on ship plates, say, at a certain price, a competing concern, with a smaller output, would not make any money at all at the same figure. In the steel trade the uncertainty over prices for Government work is reported to be making the price situation in commercial lines more confused than it has been before in this exceptional year.

Toronto Hydro Has Good Year.—The Toronto Hydro-Electric System during the year ending 31st December, 1916, has made a surplus of \$18,397. This sum would have been \$200,000 had the rates not been reduced, according to the sixth annual report, just issued. The gross income for the year totalled \$1,706,177. The cost for electric power and expenses, etc., amounted to \$1,072,134, while \$615,646 went in interest, sinking fund and depreciation, leaving a balance of \$18,396. The report shows that last year between 20,000 h.p. and 30,000 h.p. has

been supplied to munition factories. This amount will probably be greatly increased this year. The report states further that by strict economy the expenses for operation have again been put below the figures for the preceding year.

Oil Tanker Reginolite Launched.—On June 21, at the yards of the Collingwood shipbuilding Co., the fourth oil tank steamer which the company is building for the Imperial Oil Co., was successfully launched. There was no ceremony and comparatively few spectators. The new boat, which will bear the name Reginolite, is intended for ocean service. It is 250 feet over all, 43 feet 9 inches beam, and 25 feet deep to the upper deck. The motive power consists of a set of triple expansion engines, supplied with steam by two Scotch boilers, 13-6 by 11 feet, working at 180 pounds pressure. The construction of the steamer is in accord with Lloyds registry for ocean-going boats. The fifth boat of the Imperial Oil Company's order will be launched shortly, and will be named Talaroite.

Commercial Steel Outlook.—Comment heard in the steel trade in the United States shows an expectation of a decreased commercial consumption when the Government buying campaign gets under way. The shrinkage, in the opinion of steel makers, should be gradual, responsive to the rate of inflow of Government orders. There is no way of estimating the extent of steel mill capacity to be devoted to Government business this year. Buying will not mean that the orders placed are to be filled at once, although in certain lines, as ship plates and forms for ships, all haste will undoubtedly be made to fill contracts. The Government presumably will figure on requirements many months ahead and, with the pressure of manufacturing spread over a long period, no serious derangement to existing mill schedules is looked for.

Commission Will Fix Steel Prices.—At the request of Secretary Daniels and Chairman Denman of the United States Shipping Board the Federal Trade Commission will undertake an investigation looking to the fixing of an equitable price for steel. The Commission will be aided by James A. Farrell, President of the U.S. Steel Corporation and the Munitions Board of the Council of National Defence. Not only will a price be fixed for steel, but also for all materials, including coal and coke, entering into the manufacture of steel. The prices fixed by the Commission will not be arbitrarily imposed. The manufacturers will be invited to co-operate with the Government to the extent of furnishing the material for food ships and naval construction at a price the Commission considers just. Failing in its efforts at voluntary co-operation, the Commission will make a report to Congress similar to its report on coal and transportation two days ago, in which it will recommend the pooling of the steel interests of the country to be operated by a Government agency on Government account.

PERSONAL

Hon. W. J. Hanna, of the Imperial Oil Co., Toronto, has been appointed food controller by the Dominion Government.

H. R. Storey, purser of the steamer Hamonic of the Northern Navigation Co., has resigned and accepted the management of a line of steamers on Georgian Bay.

A. W. Heath, of Hamilton, Ont., executive treasurer of the C. A. S. E., after undergoing a serious operation, has left the hospital, and is now well on the way to recovery.

Frederick S. Viney, formerly with Westinghouse, Church, Kerr & Co., New York City, has assumed charge of the electrical department of F. R. J. MacPherson Co., Peterboro, Ont.

W. H. Armstrong, of Vancouver, B.C., has been appointed by the Dominion Government Director of Coal Mining Operations in south-eastern British Columbia and south-western Alberta.

Charles Newton Candee, president of the Gutta Percha and Rubber Co., has been appointed a director of the Canadian Bank of Commerce. Mr. Candee has been connected with the rubber industry for several years.

A. P. Broadhead, Superintendent of the Southern Canada Power Co., at St. Johns, Que., is leaving, on or about July 1 to assume a similar position, though with wider powers and more territory, with the same company at Granby, Que.

Frank H. Crockard, vice-president and general manager of the Tennessee Coal, Iron & Ry. Co., Birmingham, Ala., has been appointed president of the Nova Scotia Steel & Coal Co., to succeed Col. Thomas Cantley, Chairman of the Board of Directors.

Col. Thomas Cantley has resigned from the presidency of the Nova Scotia Steel & Coal Co., to assume the position of chairman of the Board of Directors. Col. Cantley has been with the company 32 years, of which 16 were spent as general manager and two as president.

J. P. Henry, who held an important position with the National Cash Register Co., of Dayton, Ohio, has taken over his duties as factory manager of the new plant of the Canada Cycle and Motor Co. at Weston, Ont. Mr. Henry is a native of Scotland.

Samuel King, of London, Ont., has been appointed managing-director of the National Steel Car Co., of Hamilton, Ont., in place of Basil Magor, who recently resigned. T. O. Scott, formerly secretary of the Canadian Tungsten Lamo Co., of Hamilton, has been appointed secretary-treasurer.

T. S. Dickson, of William Beardmore & Co., shipbuilders, Glasgow, is in this country for the purpose of selecting a site for an extensive steel shipbuilding and dry dock plant. It has been definitely settled that a plant will be built in Canada. In company with A. D. Swan, consulting engineer, Montreal, Mr. Dickson has inspected sites at Montreal, Que.; Halifax, N.S., and St. John, N.B.

OVENS

Enameling and Varnishing Ovens heated by Gas, Electricity, Steam or Coal.
Write for Booklet.

Brantford Oven & Rack Co., Ltd.
Brantford, Canada.

Hamilton Anti-Friction

BABBITT

A Dependable Metal for Speed and Pressure.

Geo. E. Jobborn, Hamilton, Ont.

"HAWK" D

CHROME

VANADIUM

STEEL



Will
Give You
Exceptional

**Shell Forging
Production**

WITHOUT AN EQUAL FOR BOTH FIRST AND SECOND OPERATION PUNCHES.

Comes to you heat-treated and ready for use.

It does not stick to the work.

There are many cases where each punch has turned out over 2,000 shells.

It means more shells, per machine per day.

STEEL OF EVERY DESCRIPTION.

**Hawkrige Brothers
Company**
303 Congress St., BOSTON, MASS.
U. S. A.

PURO

(MADE IN CANADA.)

Saves Dollars

Why let that old-fashioned faucet go on year after year wasting water—MONEY? Why more drinkery—lost, broken or carried away? Puro Sanitary Drinking Fountain stops all this needless waste. Puro saves you 35% on the water bill alone. Puro saves you all that money you spend for cups. YET Puro is always ready with a clear, cool drink with dollars in the bank.

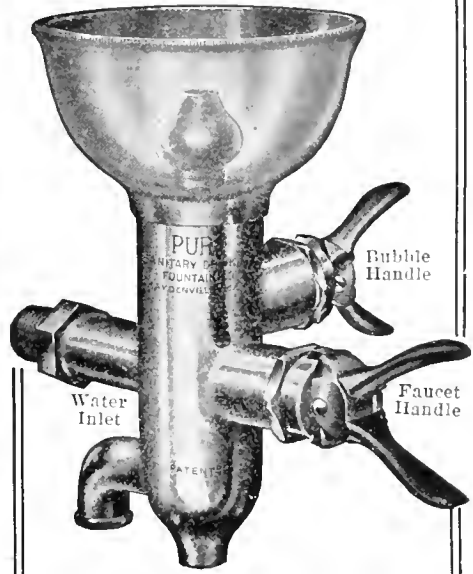

Puro Pays for Itself

You don't have to wait years to get back the small investment you have tied up in Puro equipment— You start cashing in at once—not only on your water bill saving, but on the increased efficiency of your work as well. Men like Puro—it's clean. No danger of deadly germs lurking in its sparkling bubble. Write us—tell how many men, how many departments, and we'll tell you how much the cost will be to

"PURO - FY"

YOUR WATER SUPPLY

Puro Sanitary Drinking Fountain Company
147 University Ave., Toronto, Canada

Help Wanted

An ad for help in the Classified Advertising Section will bring the right kind of replies.

Try It Out.

Canadian Machinery
Classified Advertising Section
143-153 University Ave., Toronto

THE IRON WORKS
LIMITED
Successors to
Owen Sound Iron Works
Owen Sound, Ont.
Engineers
Boiler-makers
Founders
Machinists

**Tank Work
Smoke Stacks,
Grey Iron and
Brass Castings,
Special
Machinery
Made to
Order**

George A. Morrow, president of the Imperial Life Association, Toronto, has been appointed Director of Aviation in Canada by the Dominion Government. Mr. Morrow succeeds Frank W. Baillie, who as president of the Canadian Aero-planes Ltd., Toronto will be enabled to devote more time to this concern. Both are serving without remuneration.

President Mark Workman of the Dominion Steel Corporation has left Montreal for the company's properties in the East. He will be away about two weeks. During that time he will first inspect the new blast furnaces and by-product ovens being installed at Sydney. From Sydney he will cross to Wabana, Nfld., where work has been started on the improvements planned in connection with an increased output of iron ore.

Sir Alexander R. Binnie, the well-known engineer, died at his home in Devonshire, England, in May. He carried out many important public works and was president of the Institute of Civil Engineers in 1905-6. Sir Alexander investigated the Ottawa water supply a few years ago and recommended a scheme which was afterwards abandoned on account of the heavy cost.

James R. Phillips, of the firm of J. G. Greey, mill machinery engineers, Toronto, died in the General Hospital last Friday, as the result of burning injuries sustained at the works. The late Mr. Phillips was born in the Township of Vaughan 63 years ago. On coming to Toronto he joined the John Abell Co., and later became superintendent for the Pease Foundry Co., a position which he held for 24 years. Fifteen months ago he became associated with J. G. Greey Co.

Capt. T. E. Ryder, who has recently been promoted for distinguished conduct, is manager of the Canadian Fairbanks-Morse Co., St. John, N.B., on leave of absence for active service. Capt. Ryder has also been awarded the Military Cross, and on more than one occasion mentioned in despatches. He was, previous to the war, an officer in the St. John Battery. When war broke out he immediately enlisted for active service, and was attached to the Ammunition Column, Heavy Battery.

CATALOGUES

Rubber Belting.—Booklet issued by the Goodyear Tire & Rubber Co., Toronto, containing a standard rubber belting price list and a list of firms using this concern's goods.

Air Compressors.—The Canadian Ingersoll-Rand Co., Montreal, have issued a new bulletin describing their class FL-1 steam-driven, single stage, straight line, air compressors. The construction and principal features of this machine are described fully, accompanied by detail illustrations and general views.

Air Compressors.—Bulletin K-302, 16 pages 6 x 9 in. illustrating a line of steam driven, straight line, single stage air compressors manufactured by the Canadian Ingersoll-Rand Co., Ltd., of Montreal. The type of machine described is designed to cover the field of those

requiring compact, self-contained units of small and medium size for service in shop, foundry, mill or electrical plant, etc. Automatic splash lubrication, dust-proof construction. "Circo" silent leaf valves and quick convertibility to melt drive are among the leading features of the design dwelt upon in this publication.

Pipe Threading Machinery, made by the Landis Machine Co., Waynesboro, Pa., is the title of catalogue No. 23, just off the press. This catalogue illustrates and describes in detail the Landis stationary pipe die head, pipe threading and cutting machines, pipe and nipple threading die heads, pipe and nipple threading machines, and the Landis chaser grinders. The catalogue sets forth the distinctive features of the Landis product, and also contains specifications covering the various types of machinery described. A detailed list of parts is also included.

The Stroh Steel Hardening Process Co., Pittsburgh, Pa., have issued an attractive-looking catalogue describing the Stroh process for making steel castings. The catalogue states what the Stroh process is and the theory of it. A number of steel castings, made by this process, are illustrated, showing the suitability of this method, particularly for making castings for certain purposes, such as gear wheels, pinions and car wheels, etc., where the service is exceptionally severe. The including pages trace the history of steel castings from pre-historic times until the present day featuring the Stroh process.

BOOK REVIEW

"The Driving of Machine Tools," by Thos. R. Shaw, is the title of an engineering handbook recently published by Scott, Greenwood and Son, of London E.C. Price \$1 net. In the compilation of this work it has not been the aim of the author to go extensively into the fundamental details of design, involving the use of intricate formulae and calculations, but rather to deal with the subject of machine tool drives in a general way, illustrating the various methods now in use and their application to the different tools, with a view of instructing, and possibly advising, mechanics and designers in the adaptation of certain principles, in order to attain the highest efficiency in the transmission of power to machine tools. The book is of convenient size for ready reference, being 5 by 7 inches, 220 pages, with 139 illustrations and 37 tables. The text is divided into eight chapters and an appendix, covering durability and accessibility; cone pulleys and gearing; application of care pulleys; the all gear drive; application of motor drive; planing machine drive; drives for various machines, and miscellanies. The concluding chapter of the book describes a number of auxiliary details incidental to general machine operation, such as the use of ball bearings, spiral gearing, belt drives, rules, tables, etc. This work should commend itself to any connected with the design of machine tools, or the application of drives for the operation of the same.

"Barnes-made" SPRINGS



are the result of over sixty years' experience in spring making, combined with unsurpassed equipment and the workmanship of men who have been with us, ten, twenty and in some cases thirty years.

Write for booklet No. 7-T.

Established 1857.
THE WALLACE BARNES COMPANY
218 South St., Bristol, Ct., U.S.A.
Manfrs of "Barnes-made" Products
Springs, Screw Machine Products, Cold Rolled Steel and Wire

The "Dupont" PATENT Power Hammer

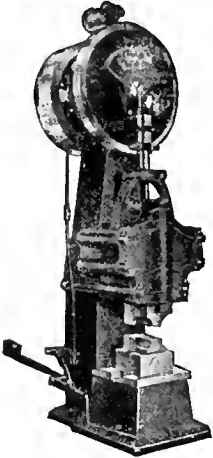

The strength, durability, economy of power and simplicity of adjustment of the Dupont Power Hammer make it a decidedly superior tool.

Made carefully from carefully selected, high-class materials.

Positively Guaranteed

Seven sizes.
With rams from 35 to 300 lbs.

Write for full details.

THE PLESSISVILLE FOUNDRY
Plessisville, Que.

Ontario and Western Agents:
The General Supply Co. of Canada Ltd
Ottawa Toronto Winnipeg



Lloyd George said:—

“We may lose some battles, but there is one battle we shall win—the last.”

But always—win or lose—behind our allied lines, *fighting* to turn out the infinite and intricate mechanism of victory, you will find



DRILLS

THE
**CLEVELAND TWIST DRILL
 COMPANY**

NEW YORK

CLEVELAND

CHICAGO

If any advertisement interests you, tear it out now and place with letters to be answered.

CLASSIFIED ADVERTISING

Rates (payable in advance): Two cents per word first insertion; one cent per word subsequent insertions. Count five words when box number is required. Each figure counts as one word. Minimum order \$1.00. Display rates on application.

SECTION

SPECIAL MACHINERY

H. C. THOMAS, GENERAL MACHINE SHOP, tools, jigs and machine repairs. 301 King St. W., Toronto. Telephone Adelaide 3836. c1m

MANUFACTURERS—WE CAN UNDERTAKE work to any specification—munition production equipment or otherwise. Write **W. H. Sumbling Machinery Co.,** 7 St. Mary St., Toronto.

S. VESSERT & CO., GENERAL MACHINE SHOP and Grey Iron Foundry. We can undertake at present time light machining and grey iron castings, at reasonable prices. Address Joliette, Que. c1m

FOR SALE

FOR SALE — 1 HOLDEN-MORGAN BASE milling machine. 3-inch shell. Manitoba Bridge & Iron Works, Winnipeg.

1 24" CONRADSON TURRET LATHE. APPLY **McGregor, McIntyre, Limited,** Toronto, Ont. c3m

FOR SALE—ONE LEWIS TYPE ENGINE built by Waterous Engine Works, 240 H.P., flywheel 73" x 18", automatic governor, a bargain. One steam pump, 4½" x 2¾" x 4". Write Box 217, Moncton, N.B. c24m

RADIAL DRILL, 4' CINCINNATI BICKFORD with single pulley drive and speed box, for sale or exchange for 6" Radial Drill; also Mitts & Merrill Keyseater, 12" stroke to cut 2" wide keyways. Boving Hydraulic & Engineering Co., Ltd., Lindsay, Ont. c26m

FOR SALE—TWO 16 x 6 REED PRENTICE Automatic Lathes. One Bertram Gap Lathe, 48 x 10. Four No. 10 Heavy Duty Baker Drills. One No. 2D Colburne Drill. One Heavy Duty Reliance Machine Co. Turret Lathe for inside boring of 6" shells. Canadian Blower & Forge Co., Kitchener, Ont. c24m

WE HAVE ON HAND AT OUR WELLAND Works, for disposal, the following new machinery:—One (1) 18" x 15 ft. Accumulator; one (1) Aldrich Triplex Hydraulic Pump, 180 gals. capacity; two (2) 350-ton B. and B. Presses. All offers will be carefully considered. Canadian Car & Foundry Co., Ltd., Transportation Building, Montreal.

1—ROBB HORIZONTAL STEAM ENGINE, 10 x 12, 35 h.p. Just overhauled by makers. Price \$300.00. **1—Heavy Duty Rockford Drill,** Suitable for shells or heavy work. Weight of drill 3,600 lbs. Good as new. Write for specification. **1—Jones & Lamson 2 x 24 Turret Lathe,** 2¼" hole in spindle, 16" swing, cone drive, collet chucks for bars up to 2" diameter. Or lathe can be fitted with standard universal chuck. Flat turret 16" diameter. Good condition. Price \$400.00. **1—Warner & Swasey Turret Lathe,** Round turret, diameter 8", hand cross feed for turret. Swing 14". Fairly good condition. Price \$200.00. **1—Bertram 2-spindle Thread Miller,** Made by makers for threading 18-pdr. shells. Now used for threading sockets. Good condition. Steel Furnishing Co., Ltd., New Glasgow, Nova Scotia. c2m

BUSINESS CHANCES

SHELL PLANT FOR SALE — COMPLETE plant—installed since 1914, for the machining and assembling of 4.5 inch H.E. shells, situated at Dartmouth, Nova Scotia, on line of Intercolonial Railway, with siding running into the works. Will sell the equipment outright, with privilege of renting the building in event of the purchaser engaging in the same business. Starr Manufacturing Co., Limited, Dartmouth, Nova Scotia, Canada. c26m

FOR SALE—A MEDIUM-SIZED TWO-STOREY brick factory situated in the best small city in Ontario. Buildings in good condition, suitable for either metal or wood-working; shipping facilities unexcelled. Two trunk lines; direct connections east, west, north and south. Educational advantages the very best. Plant will be sold at a bargain and on easy terms of payment, if desired. Apply Box 294, Canadian Machinery. c2m

WANTED

WANTED—THREE GOOD SECOND-HAND air hoists 3" diameter by 4' lift. McKinnon Dash Company, St. Catharines, Ont. c26m

300-TON PRESS SUITABLE FOR NOSING 4.5 Howitzer Shells, complete with triple pump, accumulator, and fittings. **McGregor & McIntyre, Limited,** 1139 Shaw St., Toronto, Ont. c26m

WANTED—THREAD MILLER FOR NOSE OF 4.5 mark VII shell. Must be in good order and price reasonable. **J. C. Wilson & Co.,** Belleville, Ont. c26m

FOR SALE

20" Bullard Projectile Lathe
21" Gisholt Turret Lathe
20" x 6" Florence Turret Chucking Lathe
16" x 7' Oliver Engine Lathe, new
18" x 10' Rahn-Larmon Engine Lathe, new
18" x 12' Rahn-Larmon Engine Lathe, new
3 x 36" Jones & Lamson Flat Turret Lathe, Chucking
3¼ x 36" Cincinnati Acme Flat Turret Lathe, Chucking (4)
Ford-Smith Grinders for 3" shells (12)

Allis-Chalmers Banding and Wavering Machines (10)
Copper Band Turning Machine
Greenlee Gang Boring Machine
Holden-Morgan Thread Miller

Brownell Machinery Co.
Providence, R. I.

SITUATIONS WANTED

PRACTICAL WORKS MANAGER AND ME-chanical expert with years of experience in United States and Canada, a specialist in munition work, open for engagement. Best of references. Apply Box 304, Canadian Machinery. c4m

ELECTRICAL ENGINEER—COLLEGE GRADU-ate, five years' practical experience; now employed in large industrial plant, electric-driven; responsible position desired; money not sole object; recommendations. Box 305, Canadian Machinery. c26m

TORONTO ENGINEERING AGENCY WANTS positions for thorough mechanics, toolmakers, toolsetters, grinders, borers, automatic operators, general foremen, chief munition inspectors, and men to work on marine copper piping; also for female artisans of all kinds, viz., munition inspectors, operators, superintendents, timekeepers and female elevator attendants, tall, age over thirty; matrons. Employers send to 57 Queen W., Toronto, Adel. 809. c26m

SITUATIONS VACANT

THOROUGHLY CAPABLE BRASS FOUNDRY Foreman to take charge of small foundry doing a general jobbing business and also munition work. Location Montreal. Address for information, "Brass Foreman," P.O. Box 1934, Montreal. c26m

WANTED—TWO EXPERIENCED BORING lathe hands to take charge on day and night shifts, of battery of boring lathes for 6" Mark III shell. Only men who can get good bores and high production need apply. Give in the first instance, experience, wages required and full particulars, otherwise application will not be considered. Box 317, Canadian Machinery. c26m

WANTED—ASSISTANT SUPERINTENDENT for six-inch shell factory. Must be capable of getting maximum production from an established plant and have good mechanical experience. Duties to consist chiefly in supervising production. Give full particulars in writing of previous experience, age, references, and salary required, to Henry Hope & Sons of Canada, Ltd., Peterboro. All information will be treated in the strictest confidence. c5m

TECHNICAL ADVERTISING MAN — LARGE manufacturing concern near Toronto, building a general line of heavy machinery, requires a young man to take care of its advertising; must be able to prepare machine descriptions from blue prints and to write clear, concise English; advertising experience desirable, but not necessary; please state age, nationality, experience and salary desired, and send samples of your work with first letter. Box 320, Canadian Machinery. c26m

6" SHELL FOREMAN WANTED WITH SPE-cial qualifications to get production from shop at Peterborough, Ont., which has been running on 6" shell for eighteen months. Tooling and shop inspection separately organized. Foreman to give his whole attention to obtaining maximum production. Give full particulars in first application as to previous experience, references, and salary required, otherwise application will not be considered. Apply to Box 316, Canadian Machinery. c25m

FOR SALE

Equipment used for making
18-pr. Shells.

- 1—Warner & Swasey Turret Lathe, 2" x 24", with attachments.
- 1—Linderman Double Spindle Boring Machine, with attachments for finish boring shrapnel and nose turning H.E.
- 1—Flather & Co. 14" x 5' 0" Lathe, with chuck and countershaft.
- 1—Fosdick 16" x 6' 0" Lathe, with collet chuck and countershaft.
- 1—Braopose 16" x 6' 0" Lathe, collet chuck and taper attachment.
- 1—Goldie & McCulloch Nosing Press with Dies.
- 1—Beatty Accumulator.
- 1—Lees-Bradner Thread Miller, with attachments and countershaft.
- 1—Jones & Lamson Turret Lathe, 2" x 24".
- 1—4-gallon Bowser Tank and Pump; good as new.
- 1—Cold Saw, with variable speed motor, 60 cycle, 220 volt, cuts up to 3" stock, complete with three saws.
- 1—4-Connection Pyrometer with Rheostat, made by Taylor Instrument Co.
- 1—Thermo Couples, 39" long, bent 12 1/2" from nose.
- 1—Thermo Couples, 39" long, straight.
- 1—One-Connection Tyco's Pyrometer, made by Taylor Co.
- 1—Bertram Band Turning Attachment, for 24" Lathe, Ball-bearing Centre.

All the above located at Welland. Prices, Delivery and full particulars gladly furnished.

M. Beatty & Sons, Limited
Welland, Ont.

For Sale

8" Shell Machinery

1—Jenekes Band-turning Lathe, for turning bands on 8" B.L. High Explosive Shells. This is a new machine of the latest model, and has never been used.

2—Used Smalley-General Co.'s Thread Milling Machines for milling base end of 8" B. L. High Explosive Shells. Machines equipped complete with chucks, hobs and fixtures.

THE
CANADIAN BRIDGE
CO., LTD.
Walkerville Ontario
c26m

H. W. PETRIE of MONTREAL Limited Montreal, Que.

LIST OF NEW AND USED
MACHINERY IN STOCK
FOR
IMMEDIATE SHIPMENT

ENGINE LATHES

- New 13" x 5' Lancaster Sgl. B.G., Geared Feed.
- New 15" x 6' South Bend, Sgl. B.G., Stan. Change Gears.
- S.H. 15" x 6' South Bend, Sgl. B.G., Stan. Change Gears.
- New 16" x 6' South Bend, Sgl. B.G., Stan. Change Gears.
- New 15" x 7' Oliver Dbl. B.G., Q.C. Gear, Oil Pump and Pan.
- New 16" x 24" x 10' South Bend Gap Sgl. B.G., Stan. Change Gears.
- S.H. 17" x 8' Greaves Klusman Sgl. B.G., Geared Feed.
- New, 18" x 8' Greaves Klusman Dbl. B.G., Geared Feed.
- New 18" x 8' Giddings & Lewis Dbl. B.G., Geared Feed.
- New 18" x 8' Stevens Sgl. B.G., Standard Change Gears.
- New 18" x 8' South Bend Sgl. B.G., Stand. Change Gears.
- S.H. 18" x 10' Muller Sgl. B.G., Standard Change Gears.
- New 18" x 12' South Bend Sgl. B.G., Stand. Change Gears.
- S.H. 20" x 10' Flather Sgl. B.G., Standard Change Gears.
- S.H. 30" x 10' Fay & Scott Sgl. B.G., Stand. Change Gears.

HEAVY DUTY MANUFACTURING LATHES

- New 20" x 8' Petrie Heavy Duty Manufacturing Lathes.

TURRET, SPEED AND BRASS LATHES SCREW MACHINES

- New 12" x 7' Putnam Speed Lathe.
- S.H. 15" x 5' 6" Fox Brass Lathe with Chasing Attachment.
- S.H. 30" x 10' Vilter Lathe, Friction B.G., Geared Feed with 18" Hex. Power Feed Turret.
- New No. 0 Foster Plain Head Screw Machine, with wire feed and automatic chuck.

DRILLS

- New 3' Dresses Plain Radial, Gear Box Drive.
- New 20" Excelsior, Back Geared Wheel Lever, Power Feed.
- New 20" Silver, Back Geared Wheel Lever, Power Feed.
- New 14" Leland Gifford Single Spindle Sensitive.
- S.H. 14" Avey Spindle Spindle Sensitive.
- S.H. 14" Poote-Turf Fonn.
- New No. 1 Emco Bench Single.

HACK SAW MACHINES

- New Peerless High Speed.
- New No. 1 Atkins Kwit-Kut.

GRINDING AND BUFFING MACHINES

- New 20" Ford Smith Water Tool Grinder.
- New 18" Ford Smith S.O. General Purpose Pedestal Grinder.
- New 16" Ford Smith S.O. General Purpose Pedestal Grinder.
- New 12" Ford Smith S.O. General Purpose Pedestal Grinder.
- New 12" Ford Smith S.O. Combination Grinder and Buffer.
- New 12" Ford Smith S.O. Buffing Machine.
- New Style B. Point Yankee Twist Drill Grinder.

MISCELLANEOUS

- S.H. No. 22 Garvin Vertical Milling Machine.
- S.H. No. 9 Burke Hand Milling Machine.
- New 14" National Bolt Cutter with Lead Screw Attachment.
- New No. 1 Grabo Metal Saw Table.
- New D4 Rock River Slitting Shear.
- New No. 4 Chicago Steel Bending Brake.

Telegraph, Phone or Write for Prices and Further Particulars

H. W. PETRIE of MONTREAL
LIMITED
MONTREAL, QUEBEC

PETRIE'S LIST

Of New and Used Machine Tools Stock
for IMMEDIATE DELIVERY

TURRET LATHES AND SCREW MACHINES

- 15" x 5 1/2' American, fox.
- 16" x 6' Pratt & Whitney, turret.
- 18" x 6' Prentice, high speed.
- 22" x 8' Pratt & Whitney.
- 24" x 8' Lodge & Shipley.
- 26" x 8' Fay & Scott, B.G.
- 32" x 18" Lodge & Shipley, pulley.
- 1 1/2" x 9" Acme screw machine.
- No. 2 Warner & Swasey, plain head.
- No. 6 Warner & Swasey, friction head.

ENGINE LATHES

- 15" x 6' London, back geared.
- 16" x 8 1/2' Cincinnati, D.B.G.
- 17" x 8' Blaisdell, back-geared.
- 18" x 6' New Haven.
- 18" x 10' Putnam, back-geared.
- 20" x 8' Ffield, back geared.
- 21" x 9' back-geared, single purpose (4).
- 22" x 8' Bawden.
- 24" x 11' Pond, back-geared.
- 26" x 14' Gleason, D.B.G.
- 30" x 10' Ames, back geared.
- 18" x 32" x 12' C.M.G. gap.
- 20" x 38" x 16' double back gear, gap.
- 24" x 44" x 20' C.M.C., gap.

UPRIGHT DRILLS

- 13" Perfect, 3-spindle.
- 14" Excelsior, sensitive.
- 16" Avey, 4-spindle sensitive.
- 18" Buffalo, post drill.
- 20" Perfect, lever feed.
- 22" Barnes, back-geared.
- 24" Kerkhoff, sliding head.
- 25" Prentice.
- 64" Canedy-Otto, wall radial.
- No. 10a Baush, 16-spindle.
- No. 1/2 Avey, ball-bearing, bench.

GRINDERS

- No. 1 Wilmarth & Morman.
- No. 1 Cincinnati, universal tool.
- No. 2 Landis.
- No. 2 Sellers, universal.
- No. 3 Modern, universal.
- No. 14 Besly.
- 26" Gardner, disk.

IRON PLANERS

- 20" x 20" x 5' Bertram.
- 24" x 24" x 6 1/2' Bertram.
- 24" x 34" x 8' Cincinnati, 2 heads.
- 25" x 25" x 12' Lodge & Davis.
- 36" x 36" x 10' Sellers, 4 heads.
- 40" x 40" x 12' New Haven, power feed.

MILLING MACHINES

- Nos. 0 and 1 Burke, hand feed.
- Bertram, plain.
- Brown & Sharpe, power feed, plain.
- Fitchburg, geared, plain.
- Monarch, vertical.
- Loudon, universal.

SHAPERS.

- 16" Hendey.
- 16" Queen City, back geared.
- 20" Cincinnati, back geared.
- 24" Gould & Eberhardt.
- 30" Morton, draw cut.

MISCELLANEOUS

- 6" and 8" Racine Hack Saws.
- 4" and 6" Robertson Hack Saws.
- 6" Kennedy Cutting-off Machine.
- 12" Hall Pipe Machine.
- No. 2 Colburn Keysetter.
- No. 4A High Speed, Riveting Hammer.
- Nos. 1 and 1 Greenard Arbor Presses.
- No. 2 West Fire Hydraulic Press.
- Brown-Boges Punching Press.
- Bertram Single-end Punch and Shear.
- No. 3 Dundas Double-end Punch and Shear.
- 7' Geared Bending Rolls.
- 1500-lb. Toledo Drop Hammer.
- 450-lb. Williams Drop Hammer.

H. W. PETRIE, LTD.
FRONT STREET WEST, TORONTO

The Best Shrapnel Heat Treating Plant In Canada

HEALY'S FOUNTAIN DESIGN

For Sale at Half Cost of Installation. Capacity 1500 per 10 Hours

Economy, Quality and Quantity Absolutely Guaranteed

6—Oil Burning, Hardening and Annealing Furnaces.

4—Quenching Tanks with about 700 gallons Houghton's Oil.

Complete Pyrometer Equipment.

5—Oil Pumps for Fuel and Quenching Oil.

1—Root Blower, with motor.

1—Compression Oil Tank.

2—Extra Large Cooling Coils, pipe design.

Complete system oil piping and air piping.

This complete heat treating plant was not damaged by our recent fire and is ready now for operation.

TOOLS FOR 18 LB. SHRAPNEL

2—11 $\frac{1}{2}$ " Davis Cutting Off Machines.

2—End Centering Machines.

2—Symington Rough Turn Machines.

1—Ballard Turret Lathe, 20-inch.

1—24" Niles Engine Lathe.

1—20" Bawden Engine Lathe.

1—20" Lodge & Shipley Turret Lathe.

3—Symington Nose Tapping Lathes.

5—Symington Body Grinders.

2—Symington Finish Turn Lathes.

1—Symington Band Recess Lathe.

2—Symington Undercut and Waive Lathes.

2—18" Perkins Profile Engine Lathes.

1—18" Lodge & Shipley Engine Lathe.

1—18" Lodge & Davis Engine Lathe.

1—18" Putnam Engine Lathe.

1—20" Simplex Engine Lathe.

2—24" Davis Turret Lathes.

1—18" Essley Engine Lathe.

1—18" Rhan-Maybr Engine Lathe.

1—18" Reed Engine Lathe.

1—West Banding Press, 4, 5" size and pump.

1—Jenckes Band Turning Lathe.

2—Filing Lathes.

Assorted lots of tools, gauges, high speed steel, shafting, etc.

Above machinery is in very good working condition, slightly damaged by fire. Prices very low.

CLUFF AMMUNITION COMPANY

911 C. P. R. BUILDING

TORONTO, ONTARIO

"New York's Greatest Clearing House—New York's Lowest Prices—J. J. McCabe"

Several Large Machines Hard to secure now-a-days for immediate shipment

TURRET LATHE—Semi-Automatic, 40-in. Swing, 6 ft. 9 in. between Chuck and Turret; Hollow Spindle, 3¾-in. hole; Turret 48 in. diam., carries 5 tools on main turret and four tools on supplementary turret. Weight 22,500 lbs. Used only slightly in one of the best Tool-shops in the country.

MILLING MACHINE—"Planer type," 45 in. x 45 in. x 14 ft. "Newton."

MILLING MACHINE—"Planer type," 24 in. x 24 in. x 12 ft. "Bement-Miles."

MILLING MACHINE—"Planer type," 24 in. x 24 in. x 8 ft. "Bement-Miles."

MILLING MACHINE—Vertical, 60 in., heavy, "Bement-Miles."

MILLING MACHINE—Vertical, 42 in., heavy, "Bement-Miles."

RADIAL DRILL—6-ft. Arm, heavy, plain, "Pond Mch. Tool Co."

RADIAL DRILL—5-ft. Arm, Full Universal, swivel arm, swivel head, heavy.

RADIAL DRILL—5-ft. Arm, Half Universal, swivel head, "Miles Tool Works."

MULTIPLE DRILL—18 spindles, capacity 1-in. holes, speed box, "Baush."

SLOTTER AND KEY SEATER—30-in. stroke, "Baker Bros."

SLOTTER—12-in. stroke, "Bement."

GEAR SHAPER—For Gears up to 36 in., with Cutters, "Fellows."

CRANK SHAPER—32-in. Stroke, Single Pulley Drive, Speed Box, Smith & M.

STEAM HAMMER—2,500 lbs. Single Frame, "Bement-Miles."

NEW TOOLS FOR IMMEDIATE SHIPMENT

The very machines the market has been short of—perhaps the machines you wanted, and couldn't get.

RADIAL DRILLS—2 2½-ft. Arm, Speed Box, Single Pulley Dr., Tapping att.

RADIAL DRILLS—3 3½-ft. Arm, Speed Box, Single Pulley Dr., Tapping att.

RADIAL DRILLS—1 4-ft. Arm, Speed Box, Single Pulley Dr., Tapping att.

SHAPERS—2 16-in. Stroke, Back-geared.

SHAPERS—3 20-in. Stroke, Back-geared.

SHAPERS—2 25-in. Stroke, Back-geared.

SHAPERS—1 28-in. Stroke, Back-geared, Speed Box.

SHAPERS—2 32-in. Stroke, Back-geared, Speed Box.

PLANERS.

21"x21"x6' Gray, 1 head.
30"x30"x8' Pond, 1 head.
36"x36"x8' Putnam, 1 head.
36"x36"x11½' Sellers, 1 head.
60"x10' Bement, 3 heads.

SHAPERS.

28" Triple-grd. Smith & Mills.
24" Crank, Gould & Eber, bk.-grd.
20" Crank, Gould & Eber., bk.-grd.
16" Crank, Cinefatti, bk.-grd.
12" Traveling hd., Sellers.

TURRET LATHES.

21" Swing, gap 32", Gisholt.
2x24" Flat Turret, Slid. Hd., J. & L.
20" Swing (2), Full-Auto, Potter & J.

LATHES.

16" Swg., 6' Bed, Reed.
18" Swg., 8' Bed, Heavy, Seneca Falls.
Qk. ch. Taper, Draw-in att. Cks.
18" Swg., 8' Bed, LeBlond.
18" Swg., 10' Bed, Porter.
18" Swg., 10' Bed, Draper.
20" Swg., 11' Bed, Hamilton.
22" Swg., 10' Bed, Porter.
24" Swg., 15' Bed, Bement.
36" Swg., 16' Bed, Putnam.
26-48" Swing, 16' Bed, McCabe.
Dble.-spindle, Grd. Plate, Ck.-Jaws.
26" Swg., 15' Bed, Dble.-hd., Bridgeford
Axle Lathe.

PUNCHES AND SHEARS.

30" throat, Wm. Sellers & Co.
30" throat, Lenox Rotary Splitting Sh.
14" throat, Single-end Punch.

HAMMERS.

2500-lb., Single-frame, Bement-Miles.
1000-lb., Single-frame, Miles.
600-lb., Single-frame, Miles.
300-lb., Single-frame, Miles.
1200-lb., Belt-drop, Miner & Peck.
900-lb., Belt-drop, Williams & White.
50-lb., (2), Helve, Bradley.

NEW LATHES—IN STOCK.

7 McCabe Heavy Pattern, latest double-spindle, 26" and 18" swing, 12' beds, 6' between centers, triple-geared, hollow-spindles, 2½" holes, C-shaft, etc. Heavy deep bed and other "new features."
1 Heavy 24" x 18" semi-qn.-ch., 3-step cone, dble. bk.-gd.
3 Heavy 24" x 14", semi-qn.-ch., 3-step cone, dble. bk.-gd.
4 Heavy, 21" x 12", semi-qn.-ch., 3-step cone, dble. bk.-gd.
5 Heavy, 21" x 12", quick-change, 3-step cone, dble. bk.-gd.
4 Heavy, 21" x 10", quick-change, 3-step cone, dble. bk.-gd.
8 Heavy, 18" x 12", quick-change, 3-step cone, dble. bk.-gd.

5- Heavy, 18" x 10", quick-change, 3-step cone, dble. bk.-gd.
5- Heavy, 18" x 8", quick-change, 3-step cone, dble. bk.-gd.
2 Heavy, 16" x 8", quick-change, 3-step cone, dble. bk.-gd.
2 Standard, 16" x 6", semi-quick-change, single bk.-gd.

MISCELLANEOUS.

Boring Mill, 36" swing, turret-head, Brown & Sharpe.
Nut Tapper, six-spindle, Acme.
Lincoln Millers, tables 27" x 6".
Lincoln Miller, table 39" x 8".
Bolt Cutter, 1½", Putnam, with new dies.
Upright Drills, 20" swing, Barnes.
Hydraulic Wheel Press, 150 tons capacity, double-acting pump.
No. 2 Die-sinker, Pratt & Whitney.
Steam Riveter, 10 gap, Sellers.
Bending Rolls, 13" 3" between housings, top roll 16" diam., lower rolls 14" diam.
Cutting-off and Centering Machine, 9" double-end, Bement-Miles.
Radial Drill, 21½" arm, heavy, Bement-Miles.
Saw Filing Machine
Wolf Portable Grinder, with Motor

J. J. McCABE—149 Broadway—NEW YORK

RIVERSIDE'S Machinery List

We Own Every Tool Offered

ENGINE LATHES

- 1-28 x 10 Hamilton Standard Engine Lathe, with turret.
- 1-28 x 15 Putman Standard Engine Lathe.
- 1-22 x 14 Putman Standard Engine Lathe.
- 3-New 18 x 8 Springfield Engine Lathes.
- 1-New 16 x 8 Springfield Engine Lathe.
- 1-New 14 x 6 Springfield Engine Lathe.
- 2-16 x 8 Davis Engine Lathes, taper attachment.
- 1-18 x 6 Jones & Lamson Standard Engine Lathe.
- 1-16 x 8 Porter Standard Engine Lathe.
- 2-16 x 8 Reed Std. Lathes.
- 1-14 x 6 Lodge & Shipley Engine Lathe.
- 1-14 x 6 Springfield Engine Lathe.
- 1-14 x 6 Prentiss Engine Lathe.
- 1-14 x 6 Hamilton Engine Lathe.
- 1-14 x 6 Sebastian Engine Lathe.

TURRET AND SCREW MACHINES.

- 1-34 x 36 Jones & Lamson Flat Turret Lathe, S.G.II.
- 1-24 x 24 Jones & Lamson Flat Turret Lathe, S.G.II.
- 1-2 x 24 Jones & Lamson Flat Turret Lathe, cone head.
- 4-No. 4 Foster F.G.H. Hand Screw Machines.
- 1-No. 3 Foster F.G.H. Hand Screw Machines.
- 1-No. 5 Pierson F.G.H. Hand Screw Machine.
- 1-No. 4 Smuir & Kamen Hand Screw Machine.
- 4-New 11" Pierce Turret Lathes.
- 2-New 1 x 8 Pierce Hand Screw Machines.
- 2-2" Cleveland Automatic Screw Machines, jigger feed.

MILLING MACHINES AND PLANERS.

- 5-No. 1½ Knight Milling and Drilling Machines.
- 2-No. 13 Pratt & Whitney Lincoln Type Milling Machines.
- 1-No. 1 Cincinnati Plain Milling Machine.
- 3-Fox Hand Milling Machines.
- 1-Garvin Hand Miller.
- 1-27 x 27 x 7" Cincinnati Planer.
- 1-22 x 22 x 5" New Haven Planer.
- 1-29 x 29 x 3" New Haven Planer.

DRILL PRESSES.

- 1-24" Baker Heavy Duty High Speed Drill.
- 1-3-spindle 8" overhang Henry & Wright High Speed Drill.
- 3-12" Leland & Gifford High Speed Bench Drills.
- 5-23" Buffalo Plain Drill Presses.
- 4-6-spindle Fox High Speed Drill Presses.
- 2-4-spindle Fox High Speed Drill Presses.
- 1-3" Mueller Plain Radial Drill.
- 1-6" Mueller Plain Radial Drill.

SHAPERS AND SLOTTERS.

- 1-24" New Barker Crank Shaper.
- 1-24" Lodge & Davis Geared Shaper.
- 1-18" Hendey Geared Shaper.
- 1-16" Hendey Geared Shaper.
- 1-16" Garvin Shaper.
- 1-16" Ohio Crank Shaper.
- 1-16" Smith & Mills B.G. Crank Shaper.
- 2-16" New Springfield B.G. Crank Shapers.
- 1-24" Niles Geared Type Slotter.

PRESSES AND HAMMERS.

- 1-Waterbury Parrell Straight-sided Geared Press with double cam knock-out.
- 5-No. 2-W Bliss Wiring Presses.
- 1-800 lb. B. & S. Roll Board Hammer.
- 1-800 lb. Pratt & Whitney Roll Board Hammer.
- 1-50 lb. Scranton Belt Hammer.
- 1-21 lb. Bradley Helve Hammer.

AIR COMPRESSORS.

- 1-8 x 6 Westinghouse Steam Air Compressor.
- 1-16 x 18 x 12 Union Steam Pump Co. Steam Driven Air Compressor.
- 1-10 x 10 Ingersoll Sargent Belt-driven Air Compressor.
- 1-10 x 10 Clayton Belt-driven Air Compressor.
- 1-9 x 8 Ingersoll-Rand Belt-driven Air Compressor.
- 1-8 x 8 Fairbanks-Morse Electrical-driven Air Compressor.
- 1-8 x 8 Gardner Single Belt-driven Air Compressor.
- 1-8 x 8 Union Steam Pump Co.'s Belt Air Compressor.
- 1-7½ x 6 Chicago Pneumatic Tool Co. Belt-driven Air Compressor.
- 1-6 x 6 Chicago Pneumatic Tool Co. Belt-driven Air Compressor.

We also carry a large stock of Steam Engines, Steam Pumps, and Electrical Equipment of all kinds.

We are in the market to purchase machine tools, both large and small.

**RIVERSIDE MACHINERY
DEPOT**
17-29 St. Aubin Avenue
DETROIT, MICH.

Brand New Machine Tools

- No. 4 Le Blond Universal Miller, \$3350.
- No. 3 Modern Universal Grinders, \$2050.
- No. 2 Ott Universal Grinders, \$1550.
- No. 2 Farwell Gear Hobber, \$1550.
- 16" Cincinnati plain crank Shapers, \$625.
- No. 0 Steptoe plain Millers, \$500.
- 20" Niles back geared Shapers, \$850.
- 28" Smith & Mills Shaper, double back geared, single pulley drive, \$1500.
- 18" x 8' Ryerson Lathes, quick change gears, \$800.
- No. 2 Kemp Smith Universal Miller, \$2000.
- 15" Sebastian gap Lathes, \$600.
- No. 2 Woods Universal Grinders, \$600.
- Le Blond Universal Grinders, \$975.
- No. 2A Becker vertical Miller, \$1050.
- No. 3 Becker vertical Miller, \$1100.
- Many others. Send your inquiry.
- Big Quantity Carbon Millimeter Twist Drills at List less 35%.

M. BLUMENTHAL
517 West 159th St., New York
Telephone: 3150 Audubon

FOR IMMEDIATE DELIVERY

- No. 28—17" x 96" Brown & Sharpe Plain Grinder.
- Pratt & Whitney Vertical Surface Grinder, 36" Table.
- No. 1½ Bath Universal Grinder, complete tool room equipment.
- No. 1½ Landis Universal Grinder, for Internal and External Grinding.
- 36 ft. Niles Plate Planer.

Lynd-Farquhar Co.

Boston, Massachusetts

One Inch Space
\$2.00 Per Issue
on Yearly Order.

FOR SALE

1—Goldie & McCulloch—210 H.P. Wheelock Coreless Tandem Combined Engines—10" x 18" x 28" Stroke—10 ft. diameter—7 groove—Fly Wheel for 2" Rope. (We find 1½" Rope is the correct size to use.) \$3000.00.

1—Northey 10" x 14" x 18" Jet Condensing Pump for use with the Engines—\$500.00.

1—Canadian General Electric—100 K.W. Alternating Current Generator—Type A.T.B. Class 8/100/900 from P. 96 .5 Amp. Speed 900 volts—full load 600 volts—Cost \$1716.80—Sale price—40% Discount.

1—Canadian General Electric—4½ K.W. Direct Current Generator—Type I.B. Class 2—.4 .5 .1100—Form H—Volts no load 155—full load 125—Amp. .36—Speed 1100—used as an Exciter for large Generator. Cost \$221.50—Sale price—40% Discount.

TAYLOR-FORBES CO., Limited
GUELPH, ONTARIO

**A
MAN**

was wanted as Tool-room Foreman. He was found by a condensed ad. in

CANADIAN MACHINERY
Classified Advertising Section
143-153 University Ave., Toronto

GOOD USED EQUIPMENT

ELECTRIC TRAVELING CRANES.

- 50-Ton Niles, 61' 7" span, fish belly type, four motor, 580 volts D.C., with 10-ton auxiliary hoist.
- 20-Ton Alfred Box, 50' 0" span, fish belly type, four motor, 230 volts D.C., with 5-ton auxiliary hoist.
- Hand Cranes, 2 to 7½ Ton, 22' span, (13).

BRAKE AND PRESSES.

- 13' 6" Garrison Brake or Press, double back-gear, capacity ¼" plate full width, weight about 156,000 lbs.; condition like new.
- No. 11 Perkins (Trimming), 4" stroke, 15,500 lbs.
- No. 225 Adriance (Punch), 2" stroke, 7,000 lbs.
- No. 65 Toledo (Cam Drawing), B.G., 13,000 lbs.

PUNCHES AND SHEARS.

- Punch and Shear, cap. 3" x 1¼, throat 48".
- Punch and Shear, 17" throat, capacity 1 1-16" x 1".
- Punch and Shear, No. 5-B New Doty (hand), capacity ¾ x ½".
- Punch, Ohl (Hand), cap. ¼" x ¼".
- Punch and Shear, for elliptic spring work, capacity shear 3 x ¼", spring steel.
- Rotary Bevel Shear, Lennox, cap. ½" plate.
- Rotary Splitting, Lennox, 39", cap. ¼" plate.
- Aliquot Shear, No. 2 Farrell, cap. 1" squares.
- Guillotine Shear, No. 6 Perkins, cap. 2¼" squares, weight about 16,500 lbs.

UPSETTING AND FORGING MACHINE.

- 3½" Ajax Universal Type Upsetting and Forging Machine; excellent condition.

McCoy-Brandt Machinery Co.

Office and Warehouse:

216-218 Penn Ave., Pittsburgh, Pa.

FOR SALE USED MACHINERY In First Class Condition

- 1—LeBlond Engine Lathe, 20' x 8', swings 21½", quick-change gears, compound rest, 1¾" hollow spindle, back geared, fitted with 15" 4-jaw chuck.
- 1—Lodge & Davis Engine Lathe, 24' x 8', back geared, compound rest, power cross feed, with raising blocks to swing 32".
- 8—No. 26 Becker Plain Horizontal Milling Machines, practically new.
- 4—No. 4 Improved Lincoln Millers, manufactured by the Hendey Machine Co., Torrington, Conn., change gear box, A1 condition.
- 14—Hartford Automatic Screw Machines, manufactured by Pratt & Whitney Co., Hartford, Conn., ranging in capacity from 1" to 2½". These machines are in good used condition, and can be offered at attractive prices.
- 3—No. 7 Late Model Becker-Brainerd Lincoln Type Milling Machines.
- 1—24" Cincinnati Upright Drill, automatic feed, automatic stop, with tapping attachment.
- 1—28" Hoefler Upright Drill, with sliding head, positive geared feeds.
- 4—(New) 1½" x 9 Cincinnati Acme Hand Screw Machines, with friction back geared head, wire feed.
- 50—Lincoln Type Millers, consisting of No. 7 Becker-Brainerd, and other makes of similar size.

PRICES ON APPLICATION.

W. H. J. FITZGERALD & COMPANY

8 Oliver St. BOSTON 141 Milk St.

Machine Tools

IN CLEVELAND STOCK

LARGE PRESSES

- 76½ Bliss Straight Side Press, single crank, the 101 frame, double geared, friction clutch, 18" stroke, 12" die space, 7" shaft.
- 77½ Bliss Straight Side Press, single crank, the 101 frame, double geared, friction clutch, 18" stroke, 17" die space, 8" shaft.
- 78½ Bliss Straight Side Press, single crank, the 101 frame, double geared, friction clutch, 18" stroke, 24" die space, 10" shaft.
- 155½ Toledo Single Crank Toggle Drawing Press, capacity up to 25" blanks, 19" punch, will draw and lift out up to 9½".

ALSO IN STOCK.

- 2-spindle Foote-Burt Cylinder Boring Machine, spindles adj. from 4" centers to 1" centers, has 10" table feed, 3-step cone drive for 1" belt, spindles worm driven from shaft; all in excellent shape.
- 4-spindle Foote-Burt vertical cylinder boring machine, worm drive to spindles, table feed, in excellent shape.
- 3' Bickford plan radial drill, swinging square table on round column, cone drive, very good condition.
- 20" Prentice upright stationary head drill, power and hand feed, round swivel table and square base, also with hand feed only.
- 24" Barnes back-gear, power feed, stationary head drill press, round swivel table and planed base, belt feed, cone drive for 3½" belt; very good.
- 24" Amora sliding head, back gears, power feed, belt drive, 3" belt, very good.
- 14x6 LeBlond compound rest, taper att., very good.
- 14x6 LeBlond plan rest, plain turning engine lathe, back-gear, 4-step cone, hollow spindle, belt feed, power cross feed, all equipment, good condition.
- 14x6 Davis compound rest lathe, late model, good.
- 18x10 American gear, cone drive; A1.
- 2' P. & J. 7 x 14 automatic turret chucking machine, good condition.
- 24" x 14" Paul Machine Works, compound lathe, very good.
- 24" x 24" Pond lathe, arranged for shaft turning with taper att., turning rest, full of gear, good for plan and screw cutting work, very good condition.
- No. 1 Linds toll universal grinder, capacity 10" x 20" for external, internal and face grinding; machine has belt feed, overhead counter shaft; very good, \$50.00.
- 14x6 G and L Thorndike spring gear cutting machine type.
- 12" Bennett M.C. shaper, 14" table, 3" table, all power feeds, cone drive for 3" belt, 10" on cast iron table, and 1" on 10" table.
- 7½ lb. and 15 lb. Bradley upright helve hammers, good.
- 14x14 L. & S. 4 roller spring roller, 14" x 14" on spindle, 14" x 14" box, good condition.
- Pratt & Whitney 150-lb. Upright Strap, 150-lb. helve, 75-lb. Upright Strap Hammers.
- Detroit Japanning Ovens, 8' 10" x 8' x 152".
- Gisholt 28" Turret Lathe, taper attachment, M.D.
- Pratt & Whitney 48" Gap Lathe.
- Hanna No. 1262 30-ton Riveter.
- Pangborn Sand Blast, 81" rotary table, M.D.
- No. 5 Becker Vertical Milling Machine 22" round table.
- 3 800-ton G.E. Hydraulic Double Action Presses.
- 1 Toledo Toggle Press, No. 165½.
- 1 Ferracute Press, Dagg 66 Bliss Presses.
- 3 No. 60½ Rack and Pinion.
- 1 No. 77½.
- 1 No. 87 Special Geared.

CYRIL J. BATH & CO.

Offices Warehouse

128 Leader-News Bldg 1031 West Front St.

CLEVELAND, O.

ZEW MACHINE TOOLS FOR IMMEDIATE DELIVERY

- LATHES.
 - 9" x 4' Sonca Falls Bench Lathe with cone round rest and countershaft.
 - 11" x 6' Monarch Quick-change Lathes, with eye, rest.
 - 17" x 8' Sulby Quick-change Lathe, with 3-step cone and double back gear.
 - 12" x 7' Oliver Quick-change Lathe, with 3-step cone, double back gear, pan and pump.
 - 24" x 14' Wickes Standard Lathe, with 3-step cone and double back gear.
 - 24" x 12' Wickes Standard Lathe, with 3-step cone and turret tool post.
 - GRINDERS.
 - No. 2 Cincinnati 12 x 30 Plain Grinder.
 - Six-Fifteen Fitchburg Plain Grinder (Hand Feed).
 - Six-Fifteen Fitchburg Grinder (Automatic Feed).
 - No. 2 B. B. Universal Grinder (Box & 2" top up cut).
 - No. 24" Bath Universal Grinder (14 x 30" top up cut).
 - No. 3 Wilmarth & Moman Surface Grinder (18 x 24).
 - No. 2 Hammond Automatic Surface Grinder (12 x 24).
 - No. 2 Deschlein Universal Cutter and Tool Grinder.
 - No. 3 La Salle Plain Surface Grinder.
 - Capitol Internal Grinder.
 - DRILLS.
 - No. 1 S. Gaym P. G. Duplex H. Drill.
 - MILLERS.
 - No. 1 American Lincoln Type Miller.
 - No. 6 Whitney Hand Milling Machine.
 - No. 12 Valley C. B. G. Planer-Mill Machine.
 - POWER PRESSES.
 - No. 3 Niagara O-B-I Power Press.
 - No. 5 Niagara O-B-I Power Press.
 - No. 6 Niagara O-B-I Power Press.
 - No. 5 Toledo General O-B-I Power Press.
 - MISCELLANEOUS.
 - 12" Deesse Friction Drill S.C.C. Machine Power Feed to Turret.
 - No. 15 Leo Simplex Cold Metal Saw.
 - No. 18 Leo Simplex Cold Metal Saw.
 - 5" Geometric Threading Machine.
- THIS IS ONLY PART OF THE LIST SEND US YOUR INQUIRIES
- Also Working Machinery Shop Tools and Supplies.
- Address: Machinery Dept., Chas. A. Strelinger Co., Detroit, Mich

C. W. CULLEN MACHINERY CO.

LEADER-NEWS BUILDING CLEVELAND, OHIO

- American 5' Plain Radial Drill, 3" spindle, box table, h.g., tapping attachment, M.D.
- Bickford 4' Plain Radial Drill, cone drive, La Pointe Broaching Machine.
- Toledo No. 201 Spc. Double Crank Press.
- Toledo 100-lb. Board Drop Hammer.
- 2' P. & W. No. 2 Cutting-off Machines.
- Niles 48" and Industrial 36" Car Wheel Boreers.
- National Acme No. 4-D Four-spindle Drills.
- Bement-Miles & Co. 7½" Spindle Vert Drilling and Boring Mill.
- 2 No. 6 Rivett Grinders.
- Gardner No. 21 Belt-driven Disc Grinders.
- Bradley 150-lb. Upright Strap, 150-lb. helve, 75-lb. Upright Strap Hammers.
- Detroit Japanning Ovens, 8' 10" x 8' x 152".
- Gisholt 28" Turret Lathe, taper attachment, M.D.
- Pratt & Whitney 48" Gap Lathe.
- Hanna No. 1262 30-ton Riveter.
- Pangborn Sand Blast, 81" rotary table, M.D.
- No. 5 Becker Vertical Milling Machine 22" round table.
- 3 800-ton G.E. Hydraulic Double Action Presses.
- 1 Toledo Toggle Press, No. 165½.
- 1 Ferracute Press, Dagg 66 Bliss Presses.
- 3 No. 60½ Rack and Pinion.
- 1 No. 77½.
- 1 No. 87 Special Geared.

If any advertisement interests you, tear it out now and place with letters to be answered.

IMMEDIATE DELIVERY

DRILLING MACHINES

Leland H.S.B.B., Bench type.
No. 1 $\frac{1}{2}$ Knight Driller and Miller.
14" Rockford Sensitive.
20" Kern, b.g.
22" Barnes, s.h., b.g., p.f., tapping attach.
No. 25 Foote-Burt 24" Drill (new).
32" Hamilton s.h., b.g., p.f.
34" W. F. & J. Barnes, S.H., B.G., P.F.
12-spindle Multiple P. and W.
No. 30-C Bausch, 12-spindle.
20" W. F. & J. Barnes, 4-spindle.

GEAR CUTTERS

Reynolds Hobber.
No. 11 B. & S. Automatic.
30" x 9" G. & E. Auto. for spur and bevel.
24" x 7" G. & E. for spur.
No. 3 26" B. & S. for spur.
36" Walcott for spur.

GRINDERS

Yankee Drill.
Leland Universal, with power feed.
No. 23 B. & S. Gear Cutter.
8" x 30" Modern Plain (new).
14" x 20" B. & S. Plain
Garvin Hole Grinder.
Gisholt Tool Grinder.
No. 5 Diamond Water Tool.
No. 16 Gardner Disc Grinder.

LATHES

No. 3 $\frac{1}{2}$ Rivet.
No. 3 Cataract.

No. 5 Cataract.
13" x 5' P. & W. c.r. taper.
14" x 6' Davis, p.r.
14" x 6' Fairbanks, c.r. taper.
16" x 6' Prentice, c.r.
16" x 6' Bradford, c.r., q.c.g.
18" x 8' L. & S., pat. head, c.r. taper.
18" x 10' Fitchburg, c.r.
18" x 12' Barker, c.r.
20" x 14' Blaisdell, c.r.
21" x 12' New Haven, c.r.
24" x 13' New Haven, c.r.
32" x 16' Blaisdell, c.r.
36" x 20' American, t.b.g.
3 $\frac{1}{2}$ " x 60" Fitchburg Lo-Swing.

PLANERS.

30" x 30" x 8' Lodge & Davis, one head.
36" x 36" x 12' Powell, single head, arranged for two.
36" x 36" x 16' Sellers, one head.
36" x 36" x 12' Chandler, two heads, one side head.
40" x 38" x 14' Putnam, one head.
40" x 40" x 12' New Haven, one head, one side head.

SCREW MACHINES.

1" B. & S., Plain.
16" P. & W., Plain.
No. 2 Foster, Plain Head.
No. 2 Costello, Plain Head.
No. 2 P. & W., Friction Head.
No. 3 Foster, Geared Head.
No. 4 Pearson, Geared Head.

No. 3 Bardons & Oliver, Plain Head.
No. 12 $\frac{1}{2}$ Garvin, Friction Head.
No. 2-G B. & S. Automatic.
2" Cleveland Automatic.
7 $\frac{1}{2}$ " Cleveland Automatic.
2 $\frac{1}{4}$ " x 11" Acme (41).
No. 6 Warner & Swasey (3).

TURRET LATHES.

16" Garvin Friction Head, a.e. and w.f.
16" Lodge & Shipley.
25' Niles.
No. 2 Warner & Swasey, Hollow Hexagon.
2" x 24" Jones & Lamson.
3" x 36" Jones & Lamson, chucking equipment.
3" x 36" Jones & Lamson, bar equipment.
3" x 36" Jones & Lamson, Double Spindle.
21" Gisholt, with taper.
2-24" Gisholt Turret Lathes, taper attach.

MISCELLANEOUS.

3 $\frac{1}{2}$ " Acme Forging Machine.
52" Niles Car Wheel Boring Mill.
No. 1 Davis Keyseater.
No. 2 M. & M. Keyseater.
No. 3 M. & M. Keyseater.
3" Stover Pipe Machine.
6" x 14" P. & W. Thread Miller.
No. 3A La Point Broacher.
No. 1 American Air Tempering Furnace.
Belt Lacing Machine.
3-Ton Yale Duplex Hoist.
3-Ton Yale Triplex Hoist.

Stocker-Rumely-Wachs Company, 117 N. Jefferson St., CHICAGO, ILL.

IMMEDIATE DELIVERY

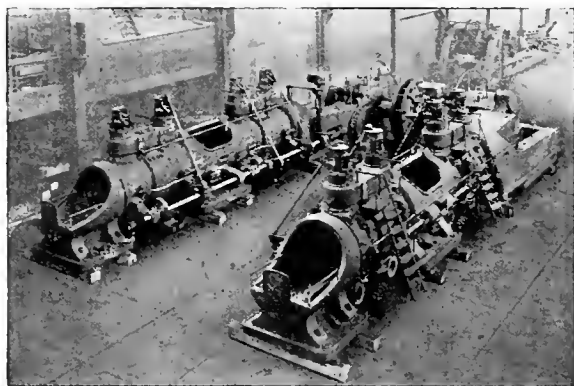

Engine on erecting floor.

One

Mesta 28" x 36" Twin Tandem

HORIZONTAL GAS ENGINE

Direct Connected to

1750 K.V.A. 60 Cycle Generator

Important and Distinctive Features:

High Mechanical and Thermal Efficiency. Positive and Correct Regulation by simplest means. Low Cost of Attendance, Depreciation and Repairs.

Write for Complete Information.

MESTA MACHINE COMPANY
P. O. BOX 1124
PITTSBURGH, PA., U.S.A.

Mention this paper when writing advertisers. It will identify the proposition about which you require information

FOR SALE

- BORING MACHINE—VERTICAL.**
 1—30" Colburn, 1 turret head.
 1—New 30" Gisholt, one turret head, Sept. delivery.
 1—34"-42" New Colburn, one turret head, Aug. delivery.
 1—34" Rogers, one turret head, Sept. delivery.
 1—36" N-B-P, one plain and one swivel head.
 2—36" B. & S., one turret head.
 1—53" N-B-P, two swivel heads.
 1—72" Niles, two swivel heads.

- BORING MACHINES—HORIZONTAL.**
 1—Lucas, 2 1/4" bar.
 1—New No. 1 Cleveland, 2 1/2" bar.
 1—Hoefler Horizontal Driller and Borer with 1 11-16" spindle, vertical adjustment 40", horizontal adjustment 46", size of table 33" x 48".
 1—No. 4 Beaman & Smith Floor Type, 5" bar, also 10" boring bar and 2 facing heads; also boring heads, with floor plate 8" x 11".
 1—Special Floor and Cylinder Borer, with 12" bar, 15 1/2" swing, vertical travel on column, but no cross travel, size floor plate 20" x 14".

- BULLDOZERS.**
 1—New No. 4 Garrison, same specification as No. 4 Williams & White.
 1—No. 7 Ajax, 20" stroke.
 1—No. 7 High-speed Ajax, 16" stroke.

- COMPRESSORS—AIR.**
 1—8" x 8" Curtis, belt-driven.
 1—10" x 10" x 10" Single Cylinder Smith-Vaile, steam driven.
 1—10" x 12" Chicago Pneumatic, belt driven.
 1—12" x 12" American, belt driven.
 1—16" x 12" Chicago Pneumatic, Duplex, belt driven.
 1—10"-16 1/2" x 13" Peerless, cross compound, steam driven.
 1—22"-13" x 16" Ingersoll-Rand, motor driven.

- CUTTING-OFF MACHINES.**
 2—No. 0 Brown & Sharpe.
 1—2" capacity Warner & Swasey.
 2—3" Curtis & Curtis.
 3—4" Curtis & Curtis.

- CRANES—ELECTRIC.**
 1—5-ton P. & W., 4-motor, 10' span, 25' lift 220 v., D.C., with one ton auxiliary hoist.
 1—8-ton Phoenix, 35' 10" span, 220 v., D.C.

- DRILLING MACHINES—RADIAT.**
 1—New 3' Mueller plain speed box drive.
 1—36" Bickford, plain, speed box drive.
 1—New 3 1/2' Mueller, cone drive, July delivery.
 1—New 3 1/2' Carlton, cone pulley drive.
 1—New 3 1/2' Western, July delivery.
 2—4' Mueller plain, speed box drive.
 1—5' Bickford, plain, speed box drive.
 1—5' American, plain, motor driven.
 5—5' Special, 2 1/2" spindle, arm does not raise and lower, hand feed.
 1—New 6' Fosdick, speed box drive, July delivery.

- DRILLING MACHINES—HEAVY DUTY.**
 2—No. 26 Foote-Burt, 44" swing, 3 1/2" capacity in solid steel.
 3—No. 14 Colburn, 24" swing, capacity 2" in solid steel.

- DRILLING MACHINES—MULTIPLE SPINDLE.**
 1—30C Baush 12-spindle, capacity 1 1/8" holes, 30" circle.
 1—Gardam, 12-spindle, capacity 3/4" holes, 14" square.
 1—No. 5 Fox, 12-spindle, rectangular head 20" x 30", capacity 1" holes, tapping attachment, speed box drive.
 1—14-spindle Baush, capacity 1" holes, 36" circle.

- GEAR CUTTING MACHINES.**
 1—16" Bilgram Bevel Gear Generator.
 1—12" G. & E. Gear Hobber.
 1—12" Gleason Bevel Gear Planer.
 1—15" Gleason Bevel Gear Planer.
 1—20" Grant-Les Gear Hobber.
 1—No. 1 20" Schuchardt & Schutte Gear Hobber.
 1—22" x 8" Gear Cutter for Spur and Bevel.

- 1—24" Fellows Gear Shaper.
 1—24" x 8" G. & E. for spur and bevel.
 1—26" x 10" Cincinnati, spur gears only.
 1—No. 3 26" B. & S., spur gears only.
 1—New 30" Flather, spur gears only.
 3—36" Fellows Gear Shapers.
 1—No. 4 36" B. & S., spur gears only.
 1—50" x 11" G. & E., spur gears only.
 1—96" Gleason, for spur and bevel gears.

- GRINDERS—UNIVERSAL—FOR CUTTERS, DRILLS, REAMERS, ETC.**
 1—New Norton, No. 1.
 1—New Wilmarth & Morman, style BX.
 1—No. 1 Cincinnati.
 1—New Walker No. 2, outfit K (capacity 9" x 26").
 4—No. 190 Wells.

- GRINDING MACHINES—CYLINDRICAL—PLAIN.**
 1—No. 11 (6 x 30") Brown & Sharpe.
 1—6" x 48" Pratt & Whitney.
 1—No. 16 (10" x 72") Brown & Sharpe.
 1—New No. 12 (8" x 26") Brown & Sharpe.
 6—12" x 24" Modern, self-contained.
 6—12" x 36" Modern, self-contained, motor driven.
 6—12" x 48" Modern, self-contained, motor driven.

- 1—10" x 50" Norton.
 1—10" x 60" Landis.
 1—16" x 66" Landis, with crank grinding attachment.
 1—14" x 72" Queen City.
 1—18" x 96" Brown & Sharpe.

- GRINDING MACHINES—CYLINDRICAL—UNIVERSAL.**
 1—No. 1 P-aser, with surface grinding attachment.
 1—No. 1 1/2 (10" x 30") Landis.
 1—No. 2 (12" x 30") Brown & Sharpe.
 1—New No. 2 Bath.
 1—No. 2 1/2 (10" x 36") Bath.
 1—10" x 42" Modern.
 1—No. 3 (12" x 40") Brown & Sharpe.
 1—12" x 42" Landis.

- GRINDING MACHINES—INTERNAL.**
 1—No. 1 1/2 Landis.
 1—No. 75 Heald.
 1—No. 6 (6" x 6") Rivett.

- GRINDERS—CYLINDER.**
 1—No. 60 Heald, single pulley drive.
 1—No. 27 Brown & Sharpe.

- GRINDERS—DISC.**
 1—No. 14 Resley.
 1—New No. 17 Gardner (Pattern Makers).
 1—No. 41 Oliver (Pattern Makers).

- GRINDING MACHINES—RING.**
 1—No. 200 Heald.
GRINDING MACHINES—EDGE.
 1—No. 374 Safety Emery Wheel Co.

- GRINDING MACHINES—SURFACE.**
 4—New No. 2 Reid (same as B. & S.).
 1—No. 1 Diamond, cap. 12" x 12" x 24", automatic.
 1—New No. 2 Wilmarth & Morman.
 1—New No. 3 Wilmarth & Morman.
 1—22" x 12" x 60" Springfield, planer type, automatic.

- GRINDING MACHINES—DUPLEX.**
 1—No. 5 Bath suitable for grinding cylinders, pistons, piston rings, etc., 16" feed, swivel table, water pump.

- GRINDING MACHINES—FACE.**
 1—Diamond Free Grinder, 1' travel, 11" wheels.

- HAMMERS—POWER—FORGING.**
 1—40-lb. Bradley Helye.
 1—150-lb. Bradley Helye upright.

- HAMMERS—BOARD LIFT—DROP.**
 1—200-lb. (no name).
 1—400-lb. Hibbins & Spencer.
 1—400-lb. Toledo.
 1—400-lb. Zeh & Bahemann.

- HAMMERS—STEAM—FORGING.**
 1—New 600-lb. Bell.
 1—New 3,000-lb. Bell September delivery.

- KEYSEATERS.**
 1—Mitts & Merrill motor driven.
 2—No. 0 Mitts & Merrill.
 1—No. 60 Baker Bros.
 1—60" stroke Compton Knowles Breacher.

- LATHES—ENGINE.**
 1—11" x 6" Bradford, taper attachment.

- 2—16" x 6" LeBlond, pan bed, quick-change gears, taper attachment.
 1—16" x 6" LeBlond, quick-change gears.
 1—New 17" x 8" National, taper attachment.
 1—18" x 8" L. & S., geared head, taper.
 1—New 19" x 8" LeBlond, heavy duty.
 3—18" x 9" Chard.
 9—18" x 8" American, geared head.
 1—20" x 16" Graves-Klusman, taper attachment.

- 3—22" x 10' Davis.
 9—23" x 10' Putnam, oil pan, turrets.
 4—24" x 10' Reed.
 2—24" x 12' S. & B.
 1—24" x 14' Lodge & Shipley, patent head.
 4—24" x 14' American, quick-change.
 1—24" x 24' Perkins.
 3—New 26" x 12' Boye & Emes.
 1—26" x 24' New Haven.
 4—New 28" x 12' Boye & Emes.
 1—28" x 18" S. & B.
 5—New 30" x 14' Boye & Emes.
 3—New 32" x 12' Fitchburg pattern.
 1—36" x 15' Fifield.
 2—New 36" x 18" Putnam, triple geared.
 12—New 36" x 24' Putnam, triple geared.
 1—25"-15" x 22" McCabe, double spindle.
 1—71" x 20" Fifield, triple geared.

- LATHES — MANUFACTURING — NOT REED WCUTTING.**

- 13—No. 3X Reed-Prentice, semi-automatic.
 2—No. 2X Reed-Prentice, semi-automatic.
 6—No. 11 Amal metal, for machining and profiling 5" shells.
 3—18" Reed Grooving and Undercutting.
 3—No. 1X Reed-Prentice, semi-automatic.
 5—20" x 10' Hindman, high duty.
 18—3 1/2" x 60" Fitchburg, Lo-swing.
 60—14" x 6' Reed, Stud and Bolt.
 5—16" x 8" Fairbanks-Morse, heavy duty.
 22—18" x 8" Bottle Creek, heavy duty.
 5—20" x 8" Merschon.
 12—21" x 8" LeBlond, quick-change with attachment for grooving and facing both ends of shells with air cylinders and mandrels for 5" shells.

- 70—New Simplex, 16" x 8".

- MILLING MACHINES—KNEE TYPE—UNIVERSAL.**

- 2—New No. 1 Kempsmith.
 1—No. 1 1/2 Garvin.
 1—No. 2A Kearney & Trecker, single pulley drive.
 3—No. 2 1/2 LeBlond, Sept. delivery.
 2—No. 3H LeBlond, Sept. delivery.

- 1—No. 3 Cincinnati, single pulley drive, higher power, vertical attachment.

- MILLING MACHINES—KNEE TYPE—PLAIN.**

- 1—No. 14 Garvin.
 1—No. 0 Pratt & Whitney.
 1—No. 21 Garvin.
 3—New No. 1 Rockford.
 2—New No. 1 Kempsmith.
 1—New No. 2 Rockford.
 1—New No. 3 Kempsmith.
 1—No. 3 LeBlond.
 1—No. 3 Hendey Norton.
 1—No. 4 Brown & Sharpe.

- MILLING MACHINES—VERTICAL.**

- 3—New Bristol, 10" x 28" table, 21" power feed.
 1—New No. 4B Becker.
 2—No. 5 Becker.

- MILLING MACHINES—PLANER TYPE.**

- 1—No. 1 Beaman & Smith, two vertical spindles, working surface of table 72" x 14".
 1—No. 1 Beaman & Smith, combined vertical and horizontal, working surface of table 72" x 18".
 1—Beaman & Smith Slab Miller and Shaft Keyseater, with vertical routing attachment, working surface of table 96" x 17".
 2—Ingersoll Slab Millers, working surface of table 60" x 20".
 2—No. 1 Beaman & Smith, vertical spindle, open side, working surface of table 120" x 21", removable housing on one side.
 1—Ingersoll Single Spindle, side head, motor driven, table 96" x 30", cutter head 30" in diameter.

W. F. DAVIS MACHINE TOOL COMPANY

CHICAGO, ILL.
 32 N. Clinton St.

CINCINNATI, OHIO
 1018 Union Central Life Bldg.

CLEVELAND, OHIO
 508 Leader News Bldg.

NEW YORK CITY
 Singer Bldg.

If any advertisement interests you, tear it out now and place with letters to be answered.



GARLOCK-WALKER MACHINERY CO. LIMITED

32 FRONT ST. WEST,

TORONTO

TELEPHONE MAIN 5346

FOR IMMEDIATE SHIPMENT

- | | |
|---|--|
| <ul style="list-style-type: none"> 2—18" x 8' Standard Engine Lathes, D.B.G., Q.C. Feed. New. 1—24" x 10' Lodge & Shipley Engine Lathe, D.B.G. and Q.C.G. New. 1—24" x 12' Used Bertram Engine Lathe. 1—30" x 30" x 8' C.M.C. Planer, two heads on rail, slightly used. 1—12" Radial Drill with gear box complete, perfect condition. 1—Brown & Sharpe Universal Miller, with Dividing Heads, Used. 1—15" Pratt & Whitney Single Gear Crank Shaper, good condition. 1—Ford-Smith Shell Grinder, used for Shrapnel. Excellent condition. | <ul style="list-style-type: none"> 1—Symington 6" Cut-off Machine, tooled for British H.E. Mark III Shells. New. 1—6' Bauseh Plain Radial Drill, cone drive, No. 5 taper, good as new. 1—10' to 16' Extension Betts Vertical Boring Mill with two swivel heads. 9' table, belt driven, excellent condition. 1—Step toe 20" Back Geared Shaper. New. <p>THOR Electric Drills, Pneumatic Hammers and Drills.</p> <p>2½', 3', 3½' or 4' Carlton Radial Drills.</p> <p>Leisy-Patton Turret Screw Machines.</p> <p>Shell Machinery, Electric Motors, etc.</p> |
|---|--|

METAL and WOODWORKING MACHINERY of all Kinds



Guaranteed Tools Re-Manufactured

When writing ask about our special term plan.

- 1—16 x 7 New Oliver Tool-room Lathe, with oil pan and pump and taper attachment.
- 1—15 x 5 New Champion Tool-room Lathe.
- 1—New 6" Shell Rounding Hertenles Lathe.
- 1—Used 24 x 10 Mettison Fairlay Lathe, hollow spindle, compound rest, cabinet legs; fine condition.
- 2—18 x 8 Used Rahn-Lamson Engine Lathes, quick-change gear, double back gear, cabinet legs; in fine condition.
- 1—No. 4 Windsor Turret Lathe, automatic chuck, friction geared head.
- 2—New 15 x 5 Carroll-Jamieson Lathes, quick-change gear, oil pan and pump and taper attachment.
- 1—3 x 26 Double Spindle Jones & Lamson Lathe; good as new.

OUR SPECIAL BARGAIN—1—16" Plain Shaper with vise and countershaft.

- 1—4-sei. 26 x 26 x 8 Powell Planer, one head.
- 1—10" Back-geared Canada Machinery Corporation Shaper, first-class condition.
- 1—20" Bertram Heavy Duty Shaper.
- 1—Heavy Straight Side Press with 1" stroke, back-geared.
- 1—20" Bertram Drill Press.
- 1—24" Sliding Head Barnes Drill Press; fine condition.
- 6—New Excelsior Sensitive Drill Presses, with square and round table.
- 1—Nearly new No. 6 Hall Cut-off Machine.
- 1—Dominion Universal Grinder.
- 1—Used Wells Universal Grinder.

DOMINION MACHINERY COMPANY

Office, 110 Church Street Toronto, Ontario, Canada
Warehouse, 14 Darling Ave Phone Main 6519

MACHINE TOOLS IN STOCK

- 13' x 7' 6" NEW Carroll-Jamieson.
- 15' x 8' NEW Carroll-Jamieson.
- 12—17" x 8' NEW National, quick change.
- 18" x 10' Rahn Mayer H.S., C.R., T.A.
- 17" x 8' NEW Sidney, D.B.G., quick change.
- 6—19" x 8' NEW Sidney, D.B.G., quick change.
- 20" x 8' Prentice, H.S., C.R., T.A.
- 26"-48" x 14' NEW style, McCabe, double spindle, heavy pattern, new lathes.
- No. 3 Cincinnati high power Universal Miller.
- 3—No. 1½ NEW American plain Millers.
- No. 1 NEW Hendey Universal Miller.
- No. 0 Steptoe New hand Millers.
- 14" NEW Steptoe Shaper.
- 16" NEW Steptoe B.G. Shaper.
- 15" Bement traveling head Shaper.
- 20" NEW Steptoe B.G. Shaper.
- 24" Flather, B.G. Shaper.
- No. 3 B.&S. Universal Grinder.
- Bath Universal Grinder, 10" x 25".
- 50" x 11" Gould & Eberhardt Gear Cutter.
- 28" NEW Superior sliding head Drill.
- 3—25" NEW Superior sliding head Drills.
- D4 Colburn high duty Drills.
- 3—20" Rockford high duty drills.
- 4 Harrington Radial Drill.

FRANK TOOMEY, INC.

127-131 North Third St., PHILADELPHIA, PA., U.S.A.

NEW MACHINE TOOL EQUIPMENT

MILLING MACHINES

Gooley & Edlund "Briggs" Type "A", No. 12 Pratt & Whitney "Lincoln," built by Taylor & Fenn Co.
Sellers "Lincoln"; working surface of table 8' x 27"; cutter space 16"; automatic quick return feed on table; three-step cone drive; tight and loose pulley.
Becker large Hand Millers with complete equipment.
Van Norman No. 1 Hand Miller; regular equipment.
Pratt & Whitney No. 2 Hand Millers; regular equipment.
Garvin No. 3 Hand Millers.

PROFILERS

Garvin No. 1 Profilers.
Betts Machine Co.'s equivalent of Pratt & Whitney No. 2.
Detrick & Harvey's equivalent of Pratt & Whitney No. 2.
Newton Machine Tool Works' equivalent of Pratt & Whitney No. 2.

DRILL PRESSES

Henry & Wright Six-spindle Sensitive Drills.

MISCELLANEOUS

14" x 5' Flather Lathe with taper attachment, relieving attachment; regular equipment.
No. 2 Townsend Riveters, 1/4" capacity.
Almond 5" Geared Scroll Chucks, two sets of jaws, three-jaw.
Almond 6" Geared Scroll Chucks, sets of jaws, three-jaw.

USED MACHINERY

AUTOMATICS

Gridley 4 1/2" Single Spindle.
Potter & Johnson No. 5-A.
Potter & Johnson 5 1/2" x 10 1/2" (Semi-Automatics) old style.

DRILLS

Baker No. 310 High Duty.
Moline No. 117 "Hole-Hogs."
Foote-Burt No. 25-24" High Duty.
Colburn D-1 High Duty.
Colburn D-2 High Duty.
Rockford 12" Sensitive.
Rockford 14" Sensitive.
Washburn 14" Sensitive.
Baker 18" Sensitive.

Henry & Wright 4-spindle Sensitive.
Henry & Wright 6-spindle Sensitive.
Henry & Wright 8-spindle Sensitive.
Taylor & Fenn 2-spindle Sensitive,—old style.
Taylor & Fenn 3-spindle Sensitive,—old style.
Sprague Horizontal Bench Drills, High Speed, 1/2" capacity.

GRINDERS

Modern 12" x 24" Plain,—New style
Modern 12" x 36" Plain,—New style.
Landis 10" x 30" Plain.
Bath No. 2 1/2 Universal 10" x 36".
Cooper 3" Shell Grinders.
Gardner No. 4 Double Ring Wheel Grinders.
Greenfield Tool & Cutter Grinder.
Norton No. 1 Tool and Cutter Grinder.

GROOVING AND WAVING MACHINES

Booth-Page Specials.
Thurlof Grooving and Undercutting Machines.

LATHES

Robbins 18" x 6'.
Perkins 16" x 8'.
Lodge & Davis 20" x 8'.
Rahn-Carpenter 16" x 6' Gap.
So-Swing 3 1/2" x 60".
Ames 16" x 6'.
Sebastian 16" x 6'.
Canedy-Otto 18" x 6'.
Bradford 16" x 6'.
Myers 11" x 5'.
Seneca Falls 11" x 5' Star.
Fay & Scott 32"—50" x 12' Gap.
Mann 12" x 5'.
Reed 14" x 6'.

MILLERS

No. 1 Van Norman Hand.
Gooley & Edlund Type "A".
Pratt & Whitney No. 12 "Lincoln."
Becker No. 7 Lincoln.
Sellers Lincoln 8" x 27".
Reed Lincoln.

SCREW MACHINES

Smurr & Kamen No. 4.
Pratt & Whitney No. 3.
Hartford No. 3.
Barnes & Oliver No. 4.
Foster No. 2.

THREAD MILLERS.

Pratt & Whitney 14" Internal Thread Miller,—old style.

Lees-Bradner No. 3, capacity 4 1/2 .
Lees-Bradner No. 3-C.
Taft-Pierce for 6" shells.
Holden-Morgan 3".
Morse-Thompson No. 3-B Double Head.

TURRET LATHES

20" Steinle.

MISCELLANEOUS

Davis No. 2 Keyseater.
Whiton 2-spindle 5" Centering Machine.
Diamond 12' Cutting-Off Saw.
West Tire No. 2 Banding Presses.
Toledo No. 261—125 lb. Rope Lift Drop Hammer.
Cochran-Bly No. 2-B Cutting-Off Saw.
Standard 6" Automatic Gear Cutter.
Dwight Slate Marking Machines.
Williamson Metal Band Saws.
American No. 64-A Gas Furnace.
American No. 2 Gas Furnace.
American No. 4 Gas Furnace
Special Machines for Backing Off Cutters.
G. E. Co. Air Compressor, Set No. 141.
Frankfort Oil System with Pump.
Tapalog 1800 Degr. Fahr.
P. T. Record.
Oil Quenching Outfits.
Quigley Furnaces 21" x 18" x 22".
Deane Duplex Pump. Style 1693.
Root Pressure Blowers No. 4.
Gould 1" Rotary Oil Pump.
10" Exhaust.
National No. 3 Oil Separators.
Eastern Machine Screw Co.'s Bench Threaders.
Defiance Machine Works' Fly Wheel Balancer.
14" Exhaust Blowers.
Birdsboro Belt Lacer.
40" Buffalo Forge Blower.
Style 1-E Washburn Drill Grinder.

SPECIAL SHELL MACHINES

Special Shell Boring Lathes. 6 1/4" Hollow Spindle.
26" x 6" Riter-Conley Lathes.
18" x 32" Heavy Turning Lathes.
Jenkes No. 15 Band Turning Lathe.
Warren Hydraulic Lathes.
Allis-Chalmers Band Turning Machines 3".

INTER-CONTINENTAL MACHINERY CORPORATION

165 BROADWAY, NEW YORK

If any advertisement interests you, tear it out now and place with letters to be answered.

New York's Greatest Stock

(Partial List)

HAMMERS

- 10,000 lb. Sellers double leg Steam
- 5,000 lb. Sellers double leg Steam
- 5,000 lb. Bement double leg Steam (2)
- 2,000 lb. Morgan Steam Drop
- 1,800 lb. Billings & Spencer Board Drop
- 1,600 lb. Bement single leg Steam (2)
- 1,200 lb. Billings & Spencer Board Drop (3)
- 1,100 lb. Miles-Bement single leg Steam
- 1,000 lb. Pratt & Whitney Board Drop
- 800 lb. Pratt & Whitney Board Drop Forging
- 750 lb. Toledo Rope Drop
- 600 lb. Niles-Bement-Pond single frame Steam (2)
- 400 lb. Bement Steam (new)
- 200 lb. Bradley Upright Strap
- 200 lb. Bradley Upright Compact
- 100 lb. Niles-Bement-Pond Hand Drop
- 60 lb. Bradley Cushioned Helve (2)
- 40 lb. Bradley Cushioned Helve
- 40 lb. Gould & Eberhardt Hand Rope Drop (4)

PLATE PLANER

- 16' Dunkirk

MILLING MACHINES

- No. 4B Brown & Sharpe Plain
- No. 4 Brown & Sharpe Plain
- No. 4 Cincinnati Plain
- No. 2 Hendey-Norton Universal
- No. 2 Cincinnati Universal
- No. 2 Cincinnati Plain
- New No. 1½ American Improved Plain
- No. 1 Kempsmith Plain
- No. 1 Pratt & Whitney Plain
- No. 3½ Garvin Plain, table 12" x 36"
- Beaman & Smith 2 spindle Vertical Slab, table 24" x 48"

RADIAL DRILLS

- 6' Niles-Bement-Pond Plain, heavy duty, tapping attachment, motor driven (2)
- 3½' Niles Plain
- 3½' Prentice Plain
- 3½' Gang Plain
- 2½' Gardam Semi-Universal

**New York Machinery
Exchange, Inc.**
50 Church Street . . . New York City

We Have for Immediate Delivery the Following Second-hand Machinery in Good Oper- ative Condition

- 1 Landis No. 3 Universal Grinder 12" x 42", complete equipment, less internal grinding attachment. . \$1,500
- 1 Gisholt Turret Lathe, 21", complete with boring bar equipment and countershaft \$2,200
- 1 Gisholt Turret Lathe, 21", complete with boring bar equipment and countershaft \$1,800

These machines are particularly good value, and may be seen at our works.

A. B. JARDINE & COMPANY
HESPELER, ONT.

Rebuilt Machines For Sale

PLANERS

- 10—Sellers 25 x 25 x 6".
- 2—Sellers 25 x 25 x 8".
- 1—Putnam 24 x 24 x 8' 6".
- 1—Putnam 25 x 25 x 10".
- 1—Pond 52 x 52 x 10', three hds.
- 1—Lathe Morse 24 x 24 x 5' 6".
- 1—New Haven 24 x 24 x 7".
- 1—Wood Light 30 x 30 x 8".
- 1—Putnam 42 x 40 x 12' 6".
- 1—Wheeler Heavy, 30 x 30 x 8' 6".
- 3—16 x 8 Putnam, C. R., taper.
- 6—18 x 8 Porter, C. R., semi-quick, taper.
- 2—18 x 8 Davis, C. R., pan, pump, taper.
- 10—16 x 8 Graves-Klusman, C.R., pan, pump.
- 1—28 x 10 Niles, C. R.
- 9—20 x 6 Perkins Plain Turning, pan, pump.
- 1—14 x 6 Porter, C. R.
- 1—20 x 8 LeBlond, C. R.
- 1—13 x 5 Seneca Falls, C. R., pan.

SLOTTERS

- 1—9" Industrial Works.
- 1—12" Sellers.
- 1—16" Sellers.

AUTOMATICS

- 10—Gridley 3¼" Single Spindle.
- 1—Nat. Acme 1", four spindle.
- 2—Nat. Acme No. 54, four spin.
- 3—Cleveland 2".
- 1—Cleveland 2¼".
- 2—Gridley 2¼" single spindle motors.
- 1—Gridley 3¼" single spindle motor.
- 1—1" National Acme, double belt type.
- 1—1½" National Acme, double belt type.
- 1—No. 55 National Acme.

LATHES

- 1—30 x 8' Fitchburg, C.R., P.C.F.

MISCELLANEOUS

- 1—No. 1 Landis Universal Grinder.
- 1—No. 3 Landis Universal Grinder.
- 1—24" Aurora Sliding Head Back-Geared Drill.
- 1—Dresses 6" Plain Radial Drill.
- 3—Rockford 6-Spindle Drills, P.F.
- 1—24" Cincinnati Back-geared Shaper.
- 1—Brown & Sharpe No. 4 Plain Miller.
- 2—No. 6X Diamond Double Disc Grinders.
- 1—Ford Smith Plain Grinder.
- 3—Prentice 24" Sliding Head Drills.
- 2—Industrial 40" Drills.
- 1—36" Aurora Drill.
- 1—4½' Niles Semi-Universal.
- 1—12" Bement Traveling Head Shaper.
- 1—12" Juengst Crank Shaper.
- 1—97" Putnam Wheel Lathe, double quartering.
- 1—Sellers Slab Miller, 24x21x12".
- 1—No. 21 Lee-Simplex Saw.

This is only partial list—Send for full list

Simmons Machine Company, Inc.

NEW YORK, 1001 Singer Bldg., Telephone Cortlandt 6575
ALBANY, N. Y., 985 Broadway, Telephone 4876 Main

YOU HAVE HEARD OF THEM BEFORE

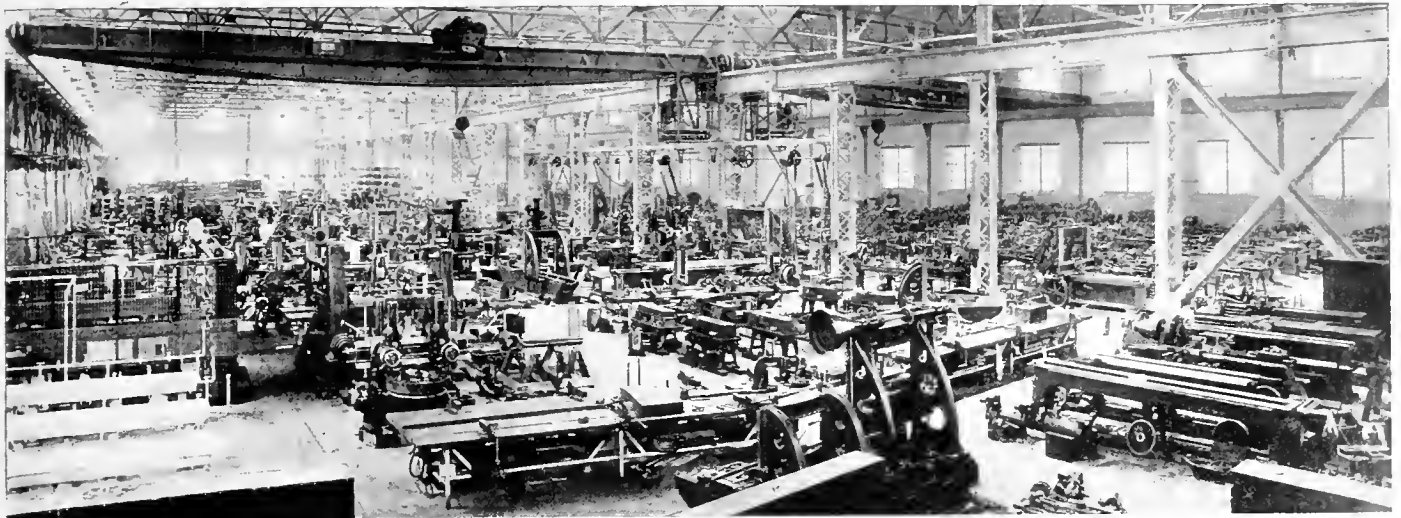

ReMANUFACTURED - (ORIGINATED BY US) - MACHINE TOOLS

IN STOCK IN CHICAGO - THE GREAT MACHINERY CENTER

HORIZONTAL BORING MACHINES.

- 1—Lucas, 3" bar.
- 1—Binsse, 3" bar.
- 1—Newark, 3" bar.
- 1—Betts, 2 7/8" bar.
- 1—Bement, 2 7/8" bar.
- 1—Binsse, 2 1/2" bar.
- 1—Beaman & Smith, 2 1/4" bar.
- 1—No. 4 Newton, 2-spindle.
- 1—Beaman & Smith 2-Spindle Cylinder Borer.
- 1—Hilles & Jones Vertical.

MILLING MACHINES.

- 1—No. 3 Kearney & Trecker, S.P.D.
- 1—No. 3 Cincinnati Univ., S.P.D.
- 1—No. 3 Hendey.
- 1—No. 2 Cincinnati Univ.
- 1—No. 20 Osterlein.
- 1 No. 5 Schuchardt & Schutte.
- 1 No. 25 Becker.
- 1—No. 0-Y Brown & Sharpe.
- 1—60" x 51" x 8' Ingersol Slab.
- 1—92" x 72" x 15' Beaman & Smith Slab.
- 1—No. 2 Beaman & Smith Horiz. and Vert.

PLANERS.

- 1—40" x 30" x 6' Gray, Spiral Geared.
- 1—36" x 36" x 10' Gray.
- 1—31" x 26" x 8' American.
- 1—32" x 32" x 10' Gray.
- 1—32" x 32" x 8' Gray.
- 1—30" x 30" x 10' Powell.
- 1—26" x 26" x 6' American.
- 1—24" x 24" x 10' Lodge & Davis.

- 1—24" x 24" x 6' Cincinnati.
- 1—24" x 24" x 6' Gray.
- 1—24" x 24" x 5' Gray.
- 1—24" x 24" x 4' Gray.
- 1—23" x 23" x 5' Flather.
- 1—22" x 22" x 6' American.

LARGE LATHES.

- 1—42" x 18' Draper.
- 11—40" x 16' Pittsburgh.
- 1—36" x 16' Springfield.
- 1—32" x 14' New Haven.
- 1—31" x 14' Pond.
- 1—31" x 12' Pond.
- 3—30" x 16' Lodge & Shipley.
- 5—28" x 14' Lodge & Shipley.
- 10—28" x 10' Pond.
- 28—26" x 12' Putnam.
- 1—26" x 12' Schumacher & Boye.
- 2—26" x 12' Wickes.
- 13—26" x 10' American.
- 1—26" x 10' Prentice.
- 1—24" x 14' Blaisdell.
- 1—24" x 12' New Haven.
- 1—24" x 12' Draper.
- 1—24" x 10' New Haven.
- 16—24" x 10' Lodge & Shipley.
- 1—22" x 16' Flather.
- 1—22" x 10' Schumacher & Boye.
- 1—22" x 10' Reed.
- 20—22" x 10' Davis.
- 38—22" x 8' Hamilton.
- 4—22" x 8' Davenport.
- 1—22" x 8' Lodge & Shipley.

LARGE TURRET LATHES.

- 4 No. 3-A Warner & Swasey.
- 99—21" Gisholt.
- 52—21" Gisholt.
- 1—22" Libby.
- 1 No. 6 Bardons & Oliver.
- 1—No. 6 Foster.
- 3—2" Gridley.
- 1—2" x 26" Pratt & Whitney G. H.
- 1—3" x 36" Pratt & Whitney.
- 2—2 1/2" x 26" Greenlee.
- 2—2" x 24" Jones & Lamson G. H.
- 3—2" x 21" Jones & Lamson Cone.

RADIAL DRILLS.

- 3—5" Niles Semi-Univ.
- 1—5" Western.
- 1—4" Niles Full Univ.
- 1—3 1/2" Gang.
- 1—3" Prentice.
- 1—3" Mueller.
- 1—2 1/2" Dreses.
- 4—2 1/2" Fosdick.
- 2—2 1/2" Mueller.

MISCELLANEOUS.

- 3—8" Nutter Barnes Cold Saws.
- 2—72" Bickford Vertical Boring Mills.
- 1—42" Betts Car Wheel Borer.
- 1—84" Poole Vertical Boring Mill.
- 3 No. 73 1/2 Bliss Presses.
- 1 No. 23 1/2-B Niagara Toggle Press.
- 1—36" Gleason Sour and Bevel Gear Former.
- 1—1 1/2" Morton Keyseater.
- 1—10" Bement Slotter.
- 2 No. 11 Brown & Sharpe Plain Grinders.

SEND FOR GREEN LIST & PICTURE BOOK.

HILL, CLARKE & CO. OF CHICAGO

625 WASHINGTON BLVD., & 125 N. CANAL ST.

SPECIAL MACHINERY

Special Machinery, Jigs, Fixtures, Punches and Dies, Small Tools, Screw Machine Products, Gauges, Forgings, Etc.

CONTRACT WORK

MANUFACTURERS OF

MARINE ENGINES POWER TOOLS

SPECIAL MACHINERY FIXTURES

GAUGES, ETC.

that desire tenders for good work, with a delivery to suit requirements, are requested to send particulars to us at once.

Several plants of large capacity and new equipment of power tools are asking us for work.

METAL MANUFACTURERS SERVICE

75 Sun Life Building

Phone Main 7777

TORONTO, CANADA

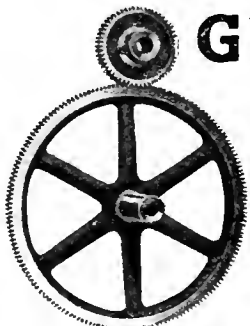

GEAR

Wheels
Cutting

of every
description

Matchless Raw-
hide Pinions in
24 hours.

PHILADELPHIA, GEAR WORKS

Vine Street, Philadelphia, Pa.

CUT GEARS

Rawhide — Steel — Brass — Cast
Iron — Spur — Bevel — Mitre.

Try our W-G Rawhide Silent
Gear. The only exclusive
gear-cutting plant in the
West.

Winnipeg Gear & Engineering Co.
197-199 Princess St., Winnipeg, Man.

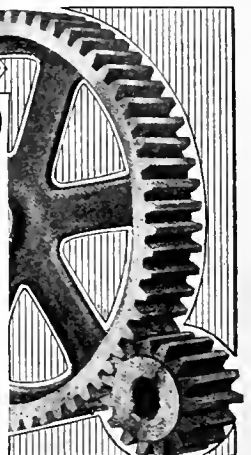

Mention this paper when writing advertisers. It will identify the proposition about which you require information.

SPECIAL MACHINERY

Special Machinery, Gears, Jigs, Fixtures, Punches and Dies,
Small Tools, Screw Machine Products, Gauges, Etc.

CONTRACT WORK

GAUGES AND TOOLS

OUR SPECIALTY

How is This?

No. 28 THREAD GAUGE FOR NOSE OF SHELL

ONLY \$35.00

CAN DELIVER FROM STOCK.

THE MONARCH BRASS MFG. COMPANY, LIMITED

71 Browns Ave., Toronto

Homer & Wilson Stamping & Tool Works

WE MAKE THE TOOLS
AND
PRODUCE THE STAMPINGS

Let us quote on your requirements.



1-3-5 Lancaster Street
Hamilton, Ontario



HIGH CARBON STRUCTURAL STEEL TUBING

BUTTED & BRAZED
BENDS & SHAPES

SHEET METAL STAMPINGS

CANADIAN METAL PRODUCTS, Limited,
GUELPH, ONTARIO

ACCURACY

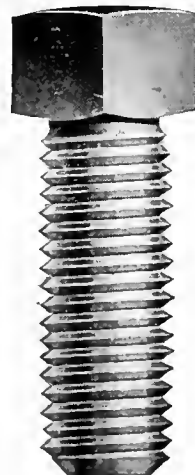

The discriminating buyer is the one we like to meet—the one who insists on accurate product. He will eventually buy "GALT" Cap and Set Screws because they measure up to his standard.

Your rush orders for S. F. Hex. nuts taken prompt care of. Better finished nuts—try a sample.

THE
GALT MACHINE SCREW CO.,
LIMITED

GALT, ONTARIO

Eastern Representatives: The Canadian B. K. Morton Company,
Limited, 49 Common St., Montreal, Que.

If any advertisement interests you, tear it out now and place with letters to be answered.

We Want Good Men

WE want a live wire representative in every good sized shop in Canada. We are willing to pay liberally for a little spare time. The work, moreover, is congenial, and whoever undertakes it will have the satisfaction of knowing that he has done his co-workers a good turn.

One of our representatives recently made \$10.00 in his spare time in one week. This is worth investigating, Mr. Foreman, Mr. Tool-maker, Mr. Timekeeper, Mr. Draughtsman, Mr. Machinist. Won't you let us send you full particulars?

COUPON

SEND US YOUR NAME

CANADIAN MACHINERY

153 University Ave., Toronto

Gentlemen:

Please send me full particulars of your proposition re representatives.

NAME.....

Street Address.....

Town.....

Where Employed.....

Position.....



Light Type Floor Grinders

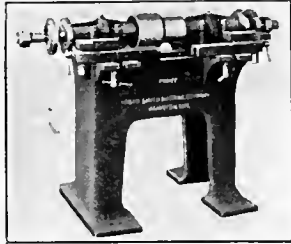

Heavy Type Floor Grinders

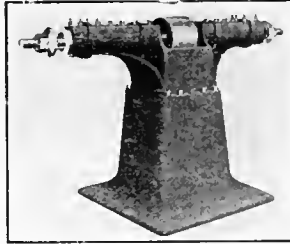

Plow Grinders



Water Tool Grinders

Ford-Smith Grinders

We can deliver quickly, and in numerous sizes, any of the Grinders illustrated.

These Highest Grade Grinders are standardized equipment in up-to-date foundries and machine shops.

Have you a copy of our latest Catalog.

The Ford-Smith Machine Co.
LIMITED

HAMILTON, CANADA

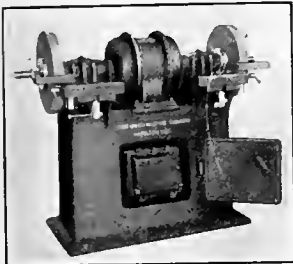

Motor-Driven Grinders

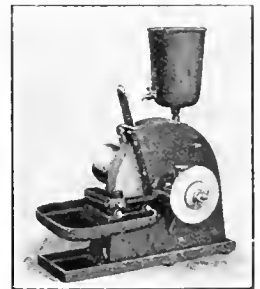

Bench Water Tool Grinders

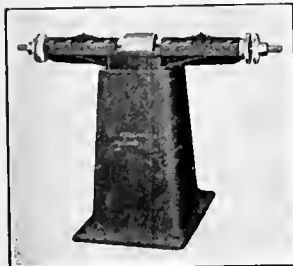

Heavy Type Polishers

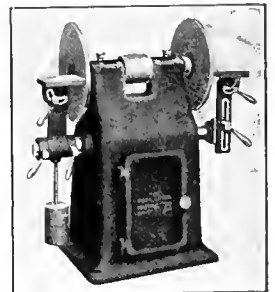

Disc Grinders



6" and 30" Double End Grinders

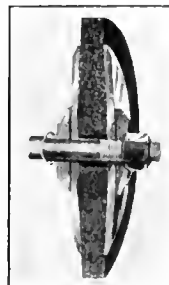

Safety Collars

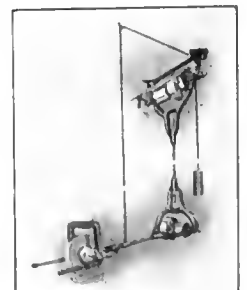

Swing Grinders

Mystic

Cutting Compound

**A Lubricant
that Operators
Appreciate**

**Far more efficient
than oil**

**Used on every operation for
Turning, Boring and Thread-
ing Shells.**

It keeps tools in the proper trim and enables them to work at their maximum efficiency.

Test at our expense. May we have the opportunity to demonstrate the merits of "Mystic" in your plant, free of cost, in order to prove our claims?

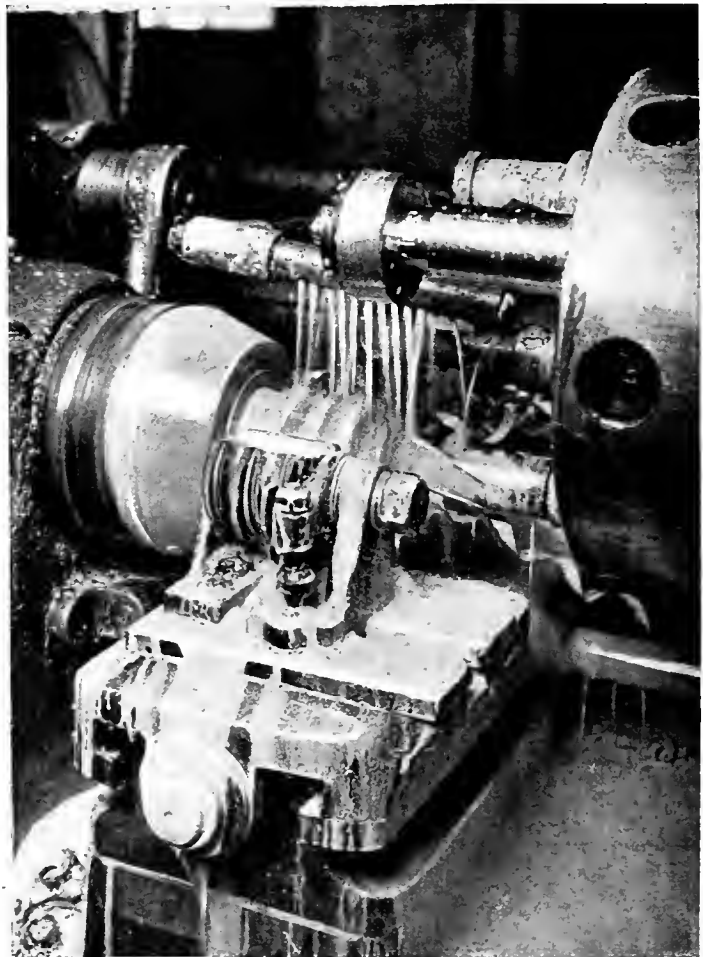

**Cataract Refining Co.
Limited**

TORONTO

CANADA

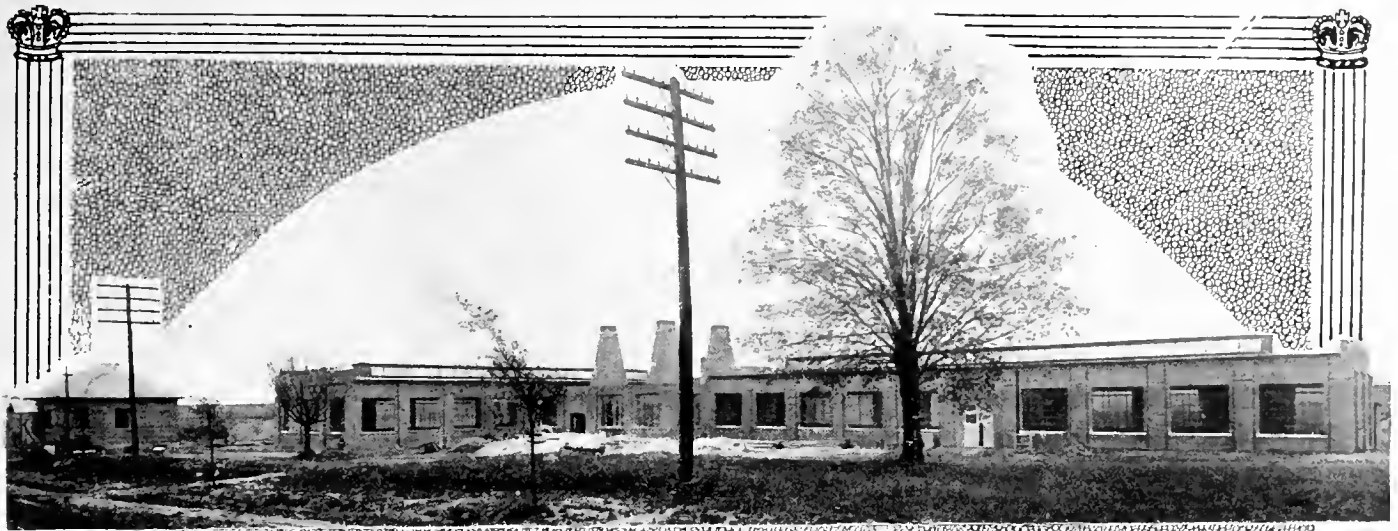

Photo shows our new plant just being completed.



DOMINION Grinding Wheels

EXOLITE (Artificial Corundum)
Wheels for Tool Room Work,
Precision and General Grinding

CARBOLOX (Carbide of Silicon) Wheels for
materials of low tensile strength such as Cast
Iron, Chilled Iron, Brass, Marble and Granite.

Produced in a new and modern plant,
just finished at Mimico, Ontario.

Manufactured by

DOMINION ABRASIVE WHEEL CO., Ltd.

MIMICO, ONTARIO, CANADA

If any advertisement interests you, tear it out now and place with letters to be answered.



If you need Hobs or
Special Cutters and ap-
preciate quality com-
bined with prompt de-
livery, write or wire

GODDARD TOOLS

**GODDARD
TOOL
COMPANY**

CHICAGO and
DETROIT

OPPORTUNITY

BECKONS YOU TO

WELLAND WELLAND

The Growing Industrial Centre Offers Great Inducements to Manufacturers

Welland is an unrivalled point for the location of industrial enterprises of all kinds. It is a natural centre for the location of manufacturers and is conceded by the captains of industry to be blessed with a Chicago-like future.

Railroad Advantages

On account of close proximity to the border, Welland is in the Buffalo switching group and takes the Buffalo rate from the East and South and enjoys quick delivery on all raw material imported from the United States.

Seven Railroads

Grand Trunk — Michigan Central — Toronto, Hamilton & Buffalo — Canadian Northern — Pere Marquette — Canadian Pacific — Wabash.

Switches or spurs are constructed on the basis of cost, the manufacturing firm paying the cost price and the railroads refunding a fixed sum for every car switched over the spur until the full amount is rebated. This rule prevails throughout the entire Dominion of Canada.

Rates from Welland to the North-West and Pacific Coast, all rail, are the same as from all other manufacturing points in Eastern Canada lying between the Detroit River and Montreal.

Ship Canal Will Carry More Vessels and Tonnage Than the Panama Canal

Welland is situated on the Welland Canal, the great Marine highway, between tide water and the Canadian North-West with daily freight service both ways.

The Canal carries boats of fourteen-foot draft, but work has now begun on canal enlargement to the amount of fifty-million dollars to provide for a twenty-five foot draft.

Distinct Advantages

In these days of keen competition water transportation has become an absolute necessity to manufacturers, and Welland holds the distinct position of being the only municipality in the entire Dominion of Canada, owning and operating its own municipal wharf, accessible by all shippers and steamboat lines alike, without charges of any kind.

Welland is a port of entry for all upper lake lines of steamers giving low rates and quick dispatch, the advantages of which are enormous.

Not even the World renowned Panama will carry the number of ships and same amount of tonnage as the Welland Canal.

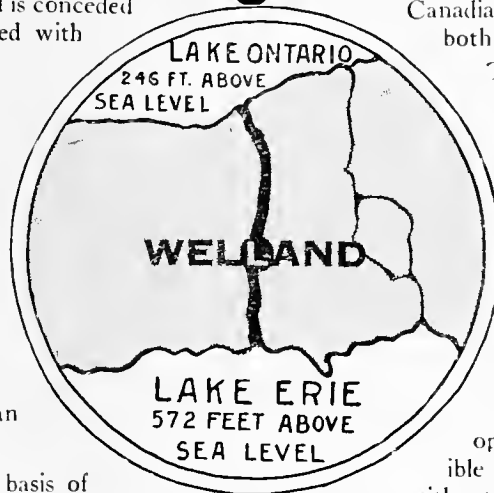

CHEAPEST POWER IN CANADA

Welland Uses More Hydro Power Than Any Ontario City

Welland is the industrial hub of the Niagara Peninsula, where an unlimited amount of electric power is available and sold at competitive prices, owing to the numerous power companies represented there.

Every factory in Welland is driven by electric power supplied by the Ontario Power Co. of Niagara Falls, which is about twelve miles east of Welland, or from the Dominion Power Co. of De Cew Falls, which is about twelve miles north of Welland. The fact that we have competitive companies operating in this district gives us competitive prices on power.

The average price per horse power per year for twenty-four hour service is about fifteen dollars. The price depends entirely upon the quantity of power used and the load factor. For ten hour service one class of meter will be installed and the power will be sold on a kilowatt basis. Our present concerns pay an average of about three-quarters of a cent per kilowatt hour. The large plants that use twenty-four hour power are securing a rate of about \$3.50 per H.P. per annum.

Welland has strong combination of advantages. Send for booklet

LOUIS BLAKE DUFF

Industrial Commissioner

WELLAND, CAN.

Welland's Present Hydro Consumption is Over 83,000 H.P.

Welland's Pay Roll Grows Bigger Even in War Time

If any advertisement interests you, tear it out now and place with letters to be answered.

MacLean's Magazine

FOR JULY

The Smugglers were Caught

THE true and complete story of a huge smuggling conspiracy which robbed the Canadian and United States Customs Departments of hundreds of thousands of dollars, and which was finally exposed by a Canadian Customs officer, is well told in the July MACLEAN'S. The parties concerned settled by handing over a huge check to the Canadian Government and not a word of the story has ever before been in print. The man who writes the article, J. D. Ronald, was personally concerned in the investigation, and he tells the whole case from first to last, merely changing the names of some of the central figures. This is one of the most striking special features that MACLEAN'S has ever had.

Confederation

the dominant theme of July MACLEAN'S

THE Jubilee of Confederation has led the Editor to make the July MACLEAN'S retrospective and interpretive of Confederation in the character of its main contents—this to meet the certain need and desire of the Canadian people. Note the fine provision of special Confederation article and features:

"THE MEETING OF MACDONALD AND BROWN."

By C. W. Jefferys, a frontispiece painted for MACLEAN'S.

"THE STORY OF CONFEDERATION."

By Thomas Bertram. A colorful narrative of the bringing about of the union of provinces.

"FIFTY YEARS OF BUSINESS EXPANSION."

By W. A. Craiek, covering all phases of business—banking, insurance, manufacturing, agriculture, transportation, etc.

"THE BUILDING OF THE C.P.R."

By C. H. Mackintosh, former Lieutenant-Governor of the North West Territories, and an ex-editor of the Ottawa Citizen.

"CONFEDERATION AND AFTERWARDS."

By Agnes C. Laut. An article on Confederation and the taking over of the North West Territories from the Hudson Bay Company.

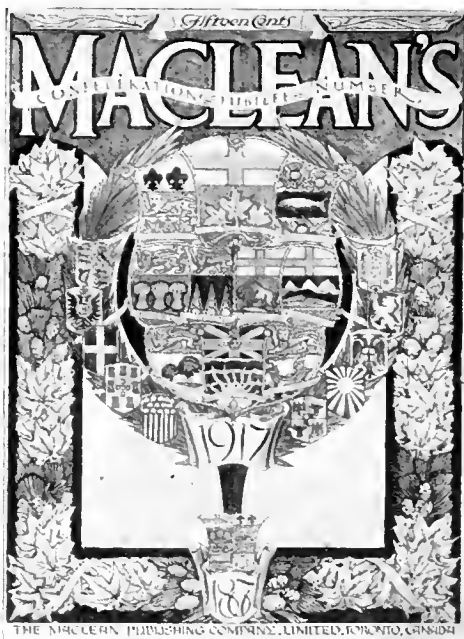

Look for this symbolic cover design in three colors at book stores and news-stands. It is a fine bit of work, and worth preserving.

"SOME CANADIAN CONTRASTS."

By Frank Yeigh. A sketchy article showing some of the most picturesque ways in which Canada has advanced during the last fifteen years.

"THE DRAFT."

By A. C. Allenson. A story of the part which Canadians took in the American Civil War.

MESSAGES ON CONFEDERATION

appear from the Premiers of many of the Provinces of Canada.

Billy Sunday Contributes:

"WHAT I THINK OF CANADA."

A brief article in the crisp, epigrammatic style of the famous evangelist, illustrated by some of his most recent photographs taken in action in New York.

The Fiction Features:

"THE GUN BRAND."

By James B. Hendryx. An interesting instalment of this exciting serial.

"THE OUTLAW BOAR."

By Clark E. Locke. A short story.

"PUTTING IT OVER."

By Hastings Webling. A golf story.

"THE CAPTAIN OF THE SUSAN DREW."

By Jack London. The first instalment of a two-part story—one of the last that London wrote.

The Best Number of MACLEAN'S

THAT has ever been put out is this July issue. It will be bigger, the articles are by long odds stronger, the stories more entertaining, and the illustrations more varied. Stephen Leacock's "Sunshine in Mariposa" is continued in this issue; also the regular Departments, Records of Success, Review of Reviews, The Business Outlook, and Information for Investors.

At All News-Dealers
15c.

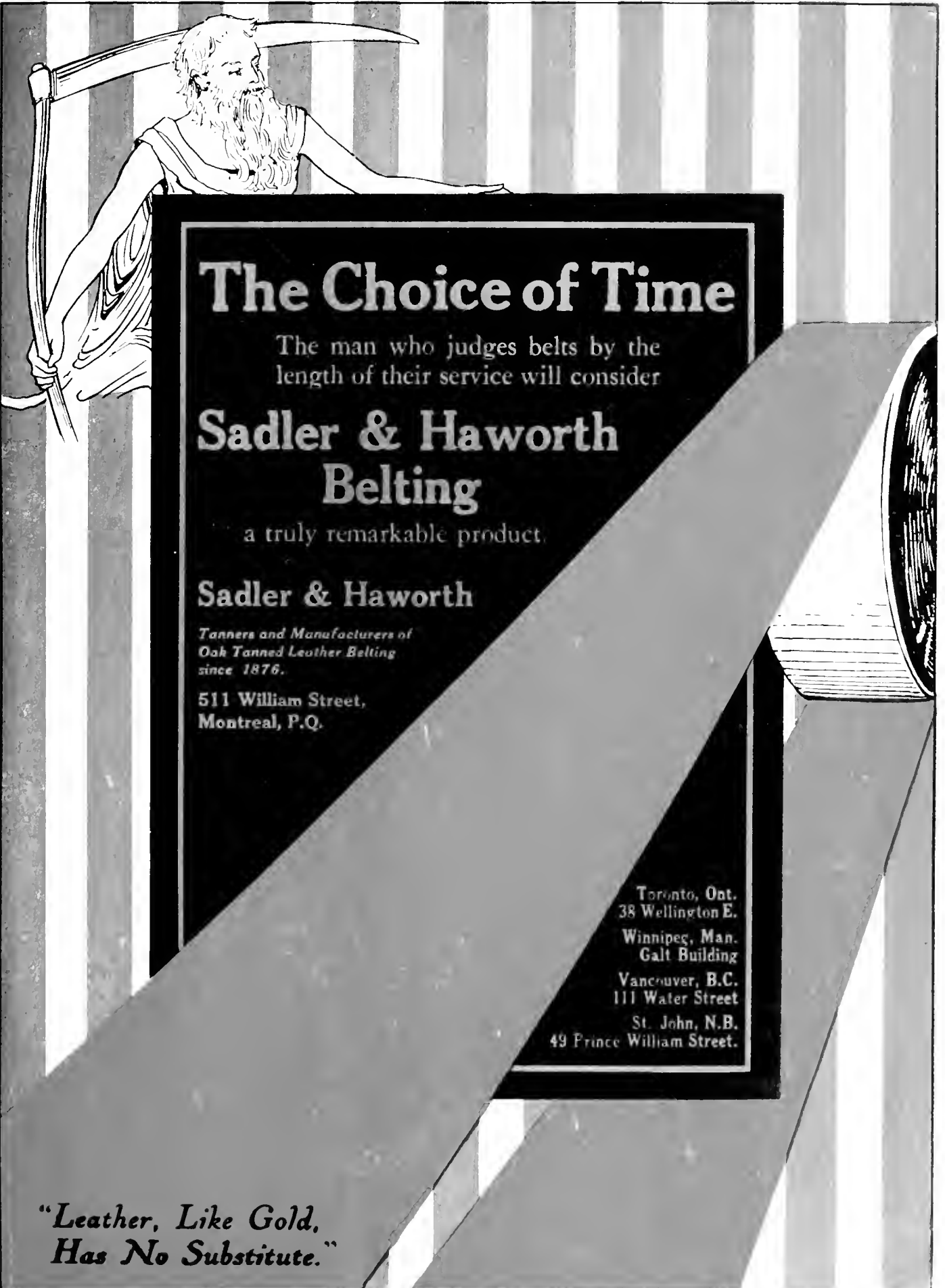

The Choice of Time

The man who judges belts by the length of their service will consider

Sadler & Haworth Belting

a truly remarkable product.

Sadler & Haworth

*Tanners and Manufacturers of
Oak Tanned Leather Belting
since 1876.*

511 William Street,
Montreal, P.Q.

Toronto, Ont.
38 Wellington E.

Winnipeg, Man.
Galt Building

Vancouver, B.C.
111 Water Street

St. John, N.B.
49 Prince William Street.

*"Leather, Like Gold,
Has No Substitute."*



WE CELEBRATE WITH
CANADA

A Business Built on a Foundation of Truth and Merit

*"To thine own self be true,
And it must follow as the night the day,
Thou canst not then be false to any man."*—Shakespeare.

The Semi-Centennial of Canada's Confederation is a fitting time to exploit the unequalled growth achieved by one of Canada's foremost metal manufacturers.

Following Shakespeare's advice "To thine own self be true, etc.," the Canada Metal Co., from a very modest beginning in 1887 has developed into a Dominion-wide industry.

A STANDARD POLICY

No Metal ever leaves our factory which we are not conscientiously satisfied is of *A-1 Harris quality through and through.*

SCIENTIFICALLY PREPARED

Modern appliances for manufacturing and a well-equipped laboratory in charge of skilled metallurgical chemists put beyond the pale of chance any inconsistency in the high quality of our alloys. The policy of honest effort to maintain our meritorious products accounts for our 30 years of success.

Harris "Heavy Pressure" is the Leading Babbitt

And is known as the Babbitt Metal "without a fault." It is best for all general machinery bearings.

Harris Heavy Pressure is a meritorious achievement of Made-in-Canada products which will bear emphasis at this time.

There's a "Canada Metal" Babbitt for every purpose and they are all reliable. Write for complete list. And remember, we guarantee our Babbitt Metals to give excellent service.

The Canada Metal Company, Limited

TORONTO

Hamilton

Montreal

Winnipeg

Vancouver



Mention this paper when writing advertisers. It will identify the proposition about which you require information.

Tate-Jones
HEAT-TREATING
Furnaces

FOR ANNEALING,
 HARDENING and
 TEMPERING of STEEL,
 and all HEAT-TREATING
 OPERATIONS.

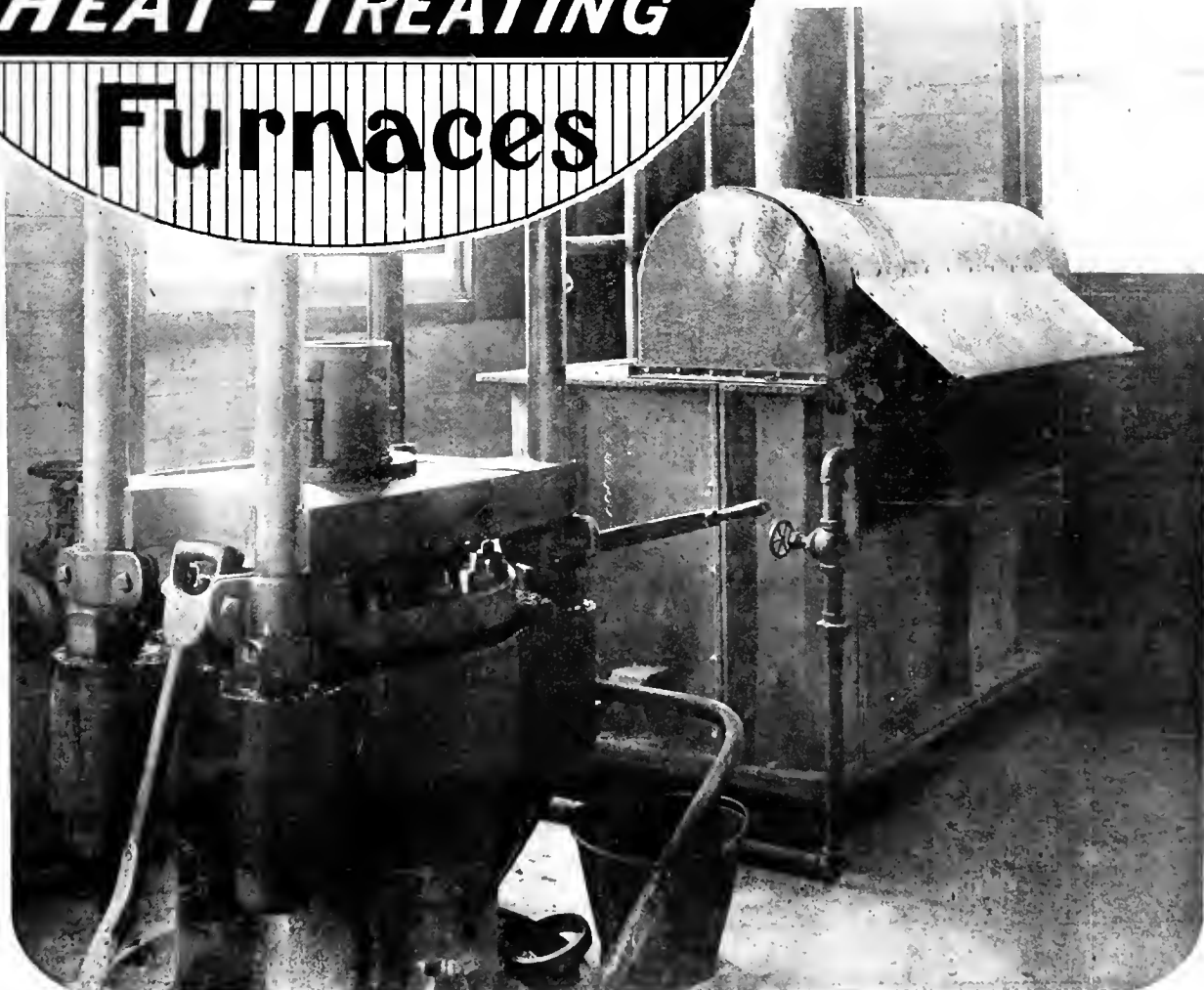

The illustration shows a Tate-Jones Furnace for the nosing-in operation on shells. Furnaces to successfully withstand the constant high temperature must be correctly designed and constructed of proper materials.

Tate-Jones gas and oil-fired furnaces have given complete satisfaction in numerous Canadian Muniton Plants.

There's a Tate-Jones furnace for every purpose—and Tate-Jones Furnaces defy comparison.

Write for circular 148-C

Tate-Jones & Company, Inc., Pittsburgh, Pa., U.S.A.
FURNACE ENGINEERS

If any advertisement interests you, tear it out now and place with letters to be answered.



BEFORE YOU BUY A PYROMETER

You may be about to buy a pyrometer. If so, you should first know all about the old-reliable Hoskins with its rugged high-torque meter, its very durable special alloy thermo-couple, the long-lived Chromel protecting tube and many other important features that have made the Hoskins Pyrometer the best in its field.

To help you select the best pyrometer for your particular requirements we have written a 48-page booklet which is not only fully descriptive of Hoskins Pyrometers but is also an instructive and interesting treatise on pyrometers in general. The attached coupon is for your convenience. Mail it to-day.

GET THIS BOOKLET

Can. Hoskins, Ltd.,
Walkerville, Ont.

Without obligating us in any way you may send us your 48-page Pyrometer Bulletin. We are interested in a

portable stationary pyrometer for use in..... recording

.....

Max. Temp. Min. Temp. Degrees C. or F.

Company

Individual

Address

512

HOSKINS

PYROMETERS

PORTABLE, STATIONARY AND RECORDING

ACCURATE DURABLE

MADE BY Canadian Hoskins, Limited

Electric, Gas and Oil Furnaces and Pyrometers

Factory and General Office: Walkerville, Ont. Eastern Office: 112 St. James St., Montreal

Tycos

VERY RADIATION PYROMETERS

Eliminate Guess-work from the Manufacture of All Products requiring extremely high Temperatures * * * *

We Manufacture - Thermometers and Instruments covering every Temperature requirement in Metallurgy and Chemistry

Canadian Office
201 Royal Bank Bldg. TORONTO

A Catalog
Cheerfully Sent
Upon Application

The Taylor-Cambridge Division
Taylor Instrument Companies
Rochester, N.Y.







Convenience

This wrench will conveniently get at that nut "just around the corner" or in other inconvenient places where a straight handled wrench would be awkward. Easily operated and handled by one hand. We can give you service and good prices.

BEMIS & CALL

Hardware & Tool Company
Springfield Mass., U.S.A.

Do These Advantages Appeal To Your Sense of Economy and Efficiency?

It's economy — requires one-half the space; costs less than half; no chimneys or flues required; instantaneous and perfect control of temperature; higher temperature obtained; no coal or ash handlers required; no coal or ash piles; less waste of fuel, because it is shut off instantly; requires much less time to get the required heat. *Can you afford to lose the Advantages of this oil Furnace?*

OIL FURNACE
VERSUS
COAL FURNACE

Write To-day for Full Particulars.

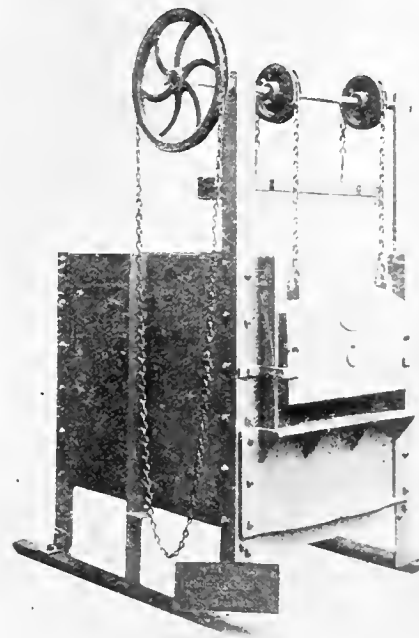

Mechanical Engineering Company, Limited

55 Cote Street

Montreal, Que.

Canada

Phone Main 3585

Cable Address: "Mecol"

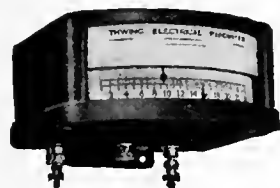

**Exact
Temperature
Measurement**

In all heat-treatment operations, Thwing Pyrometers fill every requirement. Accurate to a high degree, they still have all the rugged durability to withstand the hard usage of the tool-room, the steel mill and similar places.

Thwing Instruments are built in both the Indicating and Recording Type, giving up to 12 readings on a single recorder.

Catalog No. 8 describes the entire line. Write for your copy.

Thwing Instrument Co.
34th St. & Lancaster Ave., Philadelphia, Pa.

Canadian Representative: Mr. James DeVon
227 Davenport Rd., Toronto, Ont.

**High Speed Steel
Treated at 1750**
by pack hardening in HeTzy

a scientifically compounded and thoroughly tested preparation. Yes, and further, you will find that you

1. keep down H S steel scrap pile,
2. turn out tools with 30 per cent. more production.
3. eliminate distortion, breaking and pitting.

Prove this at our risk.

Send for 100 lb. container and try it for 30 days. If it doesn't do what we say, return the balance and you owe us nothing.

If still in doubt write for our circular and partial list of 200 representative concerns using HeTzy on all H S treatment.

Gibb Instrument Co.
5716 Euclid Ave., CLEVELAND, OHIO.

If any advertisement interests you, tear it out now and place with letters to be answered.

52 YEARS

WHERE EXPERIENCE COUNTS

There is something new to be learned about the intricate problem of heat treating every day. Over half a century's experience in burning liquid and gaseous fuels for treatment of metals has resulted in the present perfected type of G. & B. Furnaces.



TYPE E-4 FURNACE

These are the Days of Economy

Prices of labor and prices of raw material are making the cost of production hit the high spots. So economy is being shouted from the house tops! How about your heat treating? Are you getting the best results at minimum cost?

Gilbert and Barker furnaces installed in your heat treating department gives you assurance of the most efficient and economical method of production in existence.

G. & B. Furnaces are designed for convenience and ease of control, they give the right degree of heat, properly applied, with lowest possible fuel costs.

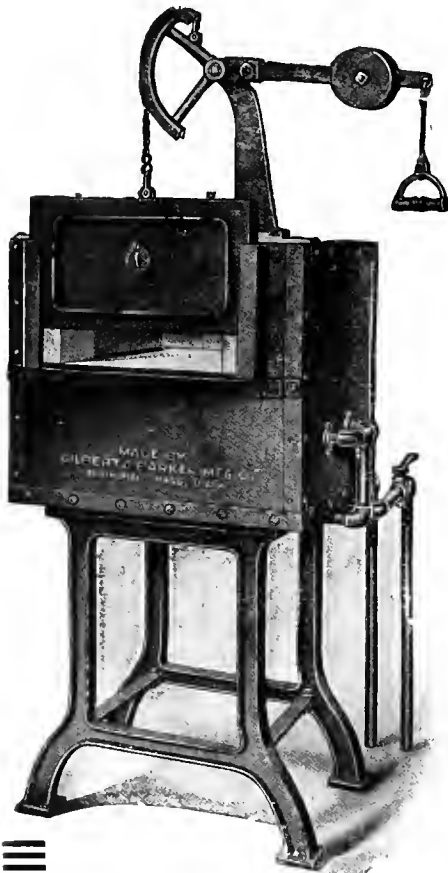

SMALL TYPE C FURNACE

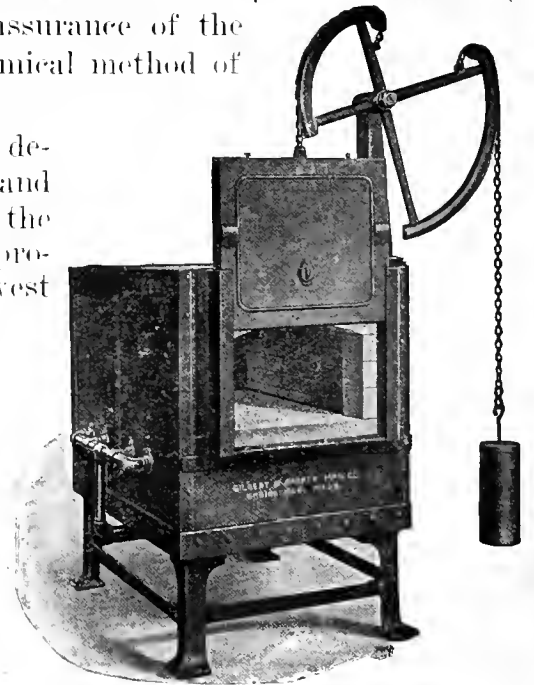

TYPE C-15

The benefit of long experience is at your service—Let us solve your heat treating problems for you. Drop a line now—delay may mean a good deal of lost money to you.

Gilbert & Barker Mfg. Co.

WEST SPRINGFIELD,
MASS.

Canadian Agents:
Williams & Wilson, Ltd., Montreal, Que.
J. DeVon, 227 Davenport Rd., Toronto, Ont.

Mention this paper when writing advertisers. It will identify the proposition about which you require information.

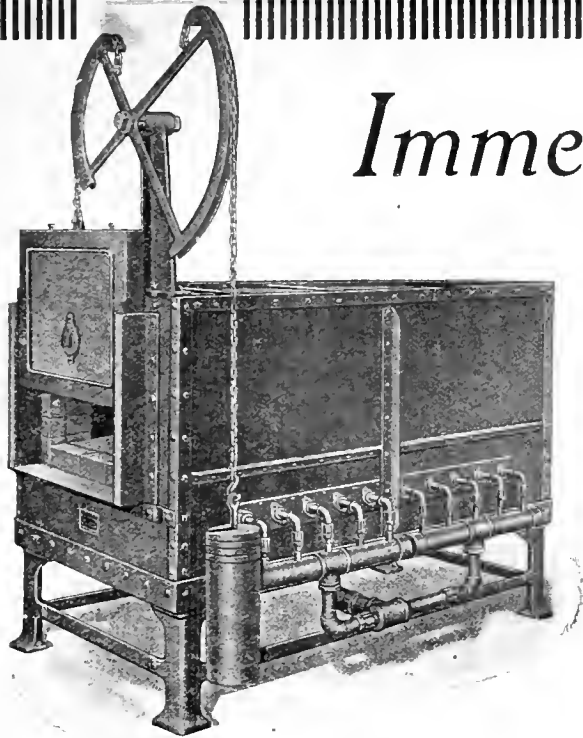

TYPE C-25 FURNACE

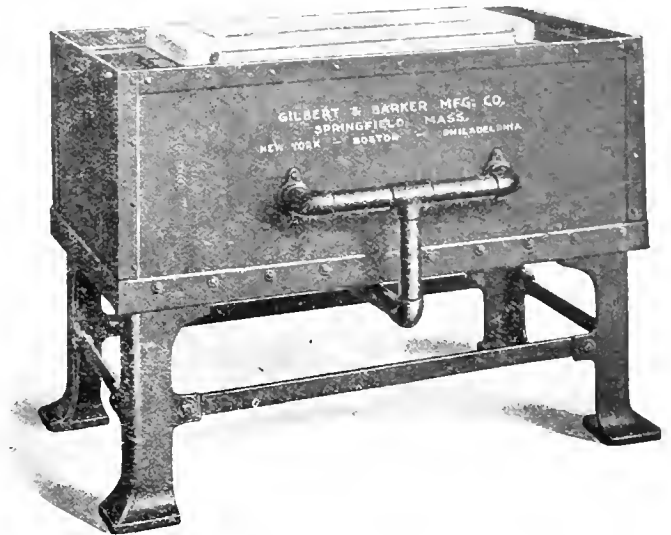

TYPE F-8 FURNACE

Immediate Deliveries

Look for Leaks in Your Heat Treating Department and Stop Them with Gilbert & Barker Furnaces

There is a Gilbert & Barker Furnace for every purpose—made in over 100 types and sizes. We are able to make immediate deliveries on nearly all types.

Look over your heat-treating department carefully for leaks. You are almost sure to discover where you can save money on a G. & B. instalment. Take this tip seriously — you'll find it worth while.

Every piece of heat-treated steel you use in your plant should come from your heat-treating department in perfect condition — to absolutely guarantee this G. & B. furnaces should be used.

Our 52 years' experience should be worth something. Put your heat-treating problems up to us.

Write To-day for Stock List 24.

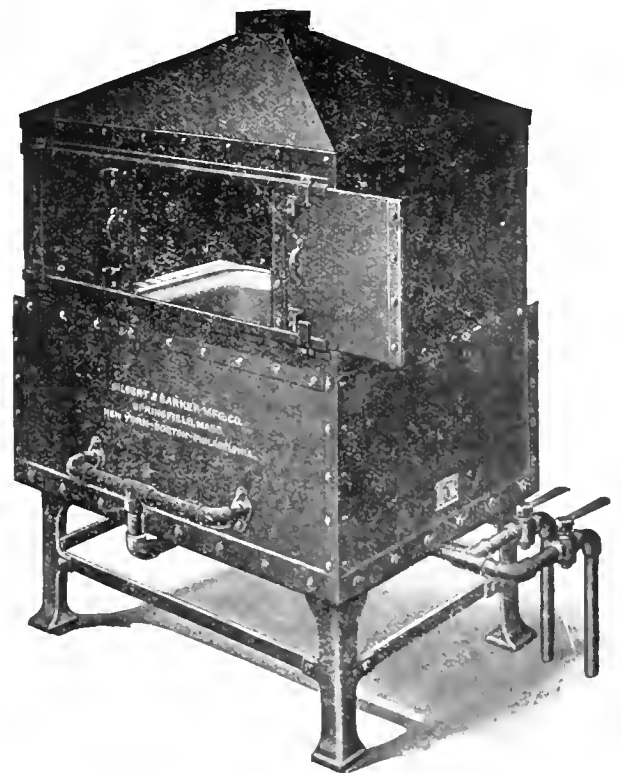

TYPE F-4 FURNACE WITH HOOD



Gilbert & Barker
 Manufacturing Co.
 WEST SPRINGFIELD, MASS.

Canadian Agents:
 Williams & Wilson, Ltd., Montreal, Que.
 Jas. DeVon, 227 Davenport Rd., Toronto, Ont.

If any advertisement interests you, tear it out now and place with letters to be answered.

Jacobs

IMPROVED

Drill Chuck

A Winner By Sheer Merit

Jacobs Improved Drill Chucks are recognized as the STANDARD the world over. Once tried—always used.

Try them and see for yourself.

MADE BY
The Jacobs
Manufacturing Co.
Hartford, Conn., U.S.A.

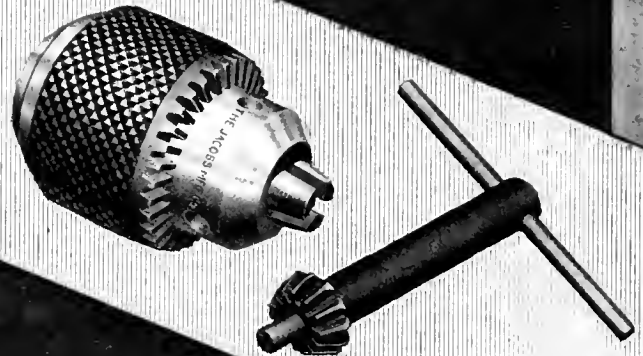

The Oven Equipment & Manufacturing Company

NEW HAVEN, CONN.

"CRAWFORD SECTIONAL" OVENS

Heated with our Enclosed Flame Gas Burners, or Electricity
FOR BAKING JAPANS AND OTHER FINISHES ON METAL.

Ovens carried in stock and built to meet requirements of manufacturers.

Builders of All-Steel Oven Trucks with Roller Bearings.

Canadian Representatives: The A. R. WILLIAMS MACHINERY COMPANY, Ltd.

ST. JOHN, N.B. TORONTO WINNIPEG VANCOUVER

How Many of Your Shells Are Being Rejected ?



Water Jacket for Nosing Furnace

This STEEL jacket holds a large amount of water, which keeps the body of shell cold, and permits of proper heating of the nose for nosing operations.

Being made of steel, it stands contraction and expansion—not possible with cast iron.

It is indestructible and fool-proof. Made for all sizes of shells.

We can make this jacket to any special dimensions, with any desired attachments. No patterns are required—specifications all that are necessary.

Tested and Guaranteed
IMMEDIATE DELIVERY.

Canadian Welding Works, Ltd., 51 Montfort Street, **Montreal, P.Q.**

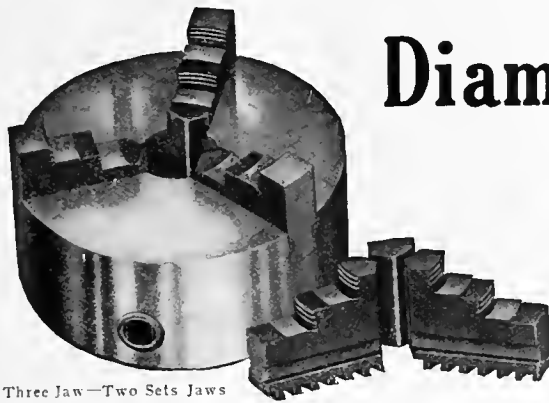

Three Jaw—Two Sets Jaws

Diamond Chucks

GEARED SCROLL TYPE

MADE BY

Richmond Manufacturing Co.

183-185 George Street, Toronto, Canada.

For Positive Accuracy—

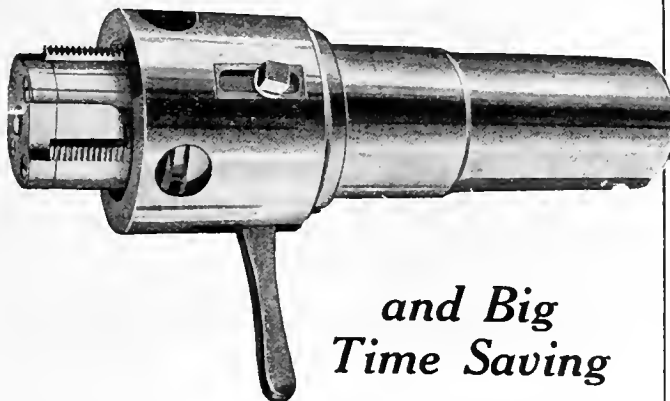

*and Big
Time Saving*

"Victor" Collapsible Taps are simple in construction; the few parts can be made large and strong; the body is machine steel, and the chasers are high-speed; screw adjustment from front end makes it easy to maintain close accuracy; trip is automatic; reset by means of lever. The above features—and others—make the "Victor" a time and money saver for severe service. It is being used by many shell manufacturers.

VICTOR Collapsible TAPS

Victor Tool Company
Waynesboro, Pa., U.S.A.

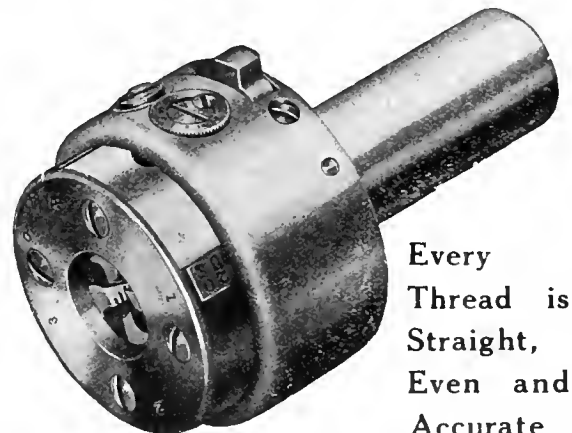

Every
Thread is
Straight,
Even and
Accurate

The Chasers in an *H & G Automatic, Self-Opening Die Head* are set and held in place by a steel cam. That cam once adjusted, locks: there is no stoppage or changing in size.

The quick release not only issues the cutting of the thread to a given point every time, but permits cutting right up to a shoulder when required.

Simple, Strong and Compact.

Our booklet tells more.

Drop a card for it.

Eastern Machine Screw Corp.
New Haven, Conn.



Here's a nasty situation!

A rush job when every minute counts, a snap and your tap has broken off close to the surface of the job.

HOW WILL YOU HANDLE IT?

Will you fuss around for half an hour or so trying to get hold of the broken piece?

Will you lose your temper and finish the job too late?

Not if you have a Walton Tap Extractor.

With this handy little device you can extract the broken piece in a jiffy and go on with your work.

The crucible steel fingers grip the flutes, a twist of your wrench and the piece is out. Investigate this further. The Walton is reasonable in price.

The Walton Company

Hartford, Conn.

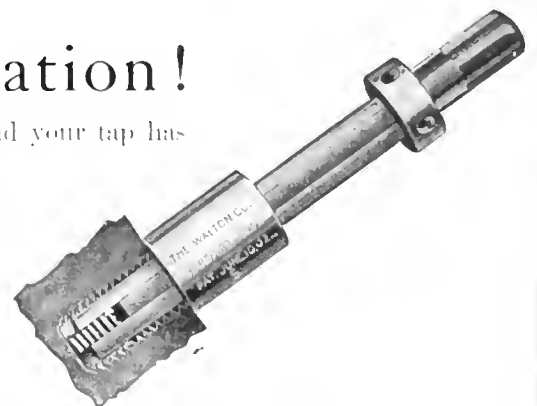

If any advertisement interests you, tear it out now and place with letters to be answered.

IDEAL DIES

Are big time savers. They make it possible for you to obtain clean, straight, absolutely accurate threads at a fast rate of production. Fineness of workmanship, quality of results and durability—all "IDEAL."

Try us.

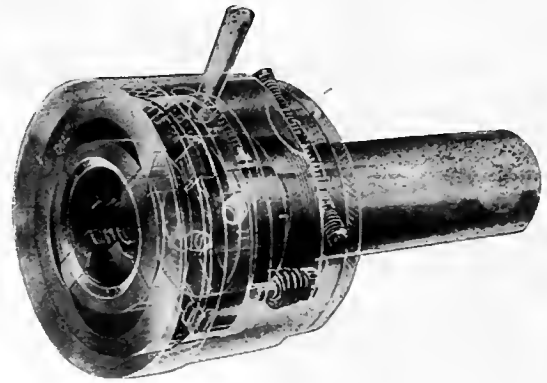
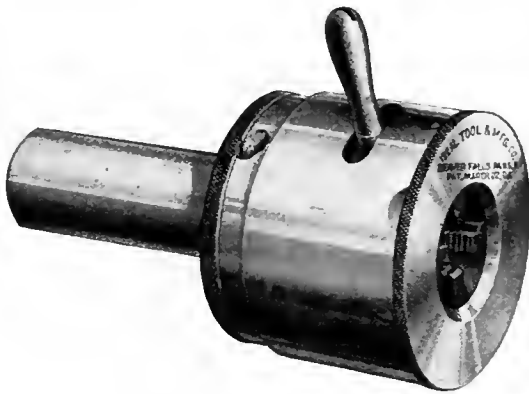

The Ideal Self-Opening Die is simple in construction, has fewer parts than any similar tool; can be quickly and easily taken apart; cuts either right or left hand threads.

Our Catalog on request.

Ideal Tool & Manufacturing Co.
BEAVER FALLS, PA.

A. M. Ellicott Co., Montreal, Quebec.
Leon Chapuis, 36 Boulevard De Meganta, Paris.
Wih. Sonesson, Malmo, Sweden.
Walter Homberger & Co., Sampierdarina, Italy.

Rapid Delivery

*Users of Murchey
Tools Get Chasers
Without Delay*

Lightning deliveries—that is a big advantage of using Murchey Tools. No work held up for chasers. We get your order, fill it, and it's on the way back to you just as quickly as the most rapid means of transportation can bring it to you.

There is no service like the Murchey service, and there are no tools like the Murchey Tools. Send blueprints for estimates.



MURCHEY TAPS are accurate and simple and can be worked with great speed. On 4.5 Mark VII shells Murchey tapping time is just ONE MINUTE.

Murchey Machine & Tool Company
75 PORTER STREET - - DETROIT, MICHIGAN

The Coats Machine Tool Company, Ltd., Caxton House, Westminster, London, S.W., England, Glasgow, Newcastle-on-Tyne, and Fenwick Freres & Company, 15 Rue Fenelon, Paris, France.

Mention this paper when writing advertisers. It will identify the proposition about which you require information.



“Little David” Tools for Shipbuilders

In wooden shipbuilding the Wood Borer shown in the cut does splendid work. It is made in three sizes, boring holes from one to four inches in diameter.

“Little David” Riveters are widely used for driving wooden trenails, short drift bolts and spikes. They are also adapted for all operations in driving oakum, “horsing,” etc.

Our CC-101 Drift Bolt Driver is a powerful and time-saving tool. With 100 lbs. air pressure, two men with this Driver can drive $1\frac{3}{8}$ " dia. bolts, 5 ft. long, 1-16" drift, full length in 25 seconds. It can be used in any position and at any angle.

For Steel Shipbuilding, our “Little David” Riveters, Chippers, Drills, Grinders, etc., will be found the most powerful and economical. Our bulletins will show you why.

We shall be glad to advise as to types and sizes of tools best suited to your work.

Your inquiries will be appreciated.

**The Canadian Ingersoll-Rand
Company, Limited**

31 Commercial Union Bldg., Montreal

FOR HARDNESS TESTING

of Shells and Other Munition Materials

THE STANDARD SCLEROSCOPE

is now universally used. It is direct reading as a thermometer and makes 5,000 tests a day. It does not leave marks on the finished work and can be operated by unskilled labor. Send for 80-page booklet free.

THE PYROSCOPE FOR HEAT TREATMENT

Is the common-sense heat measuring instrument that makes straight for results without fuss. Costs least of all; burns simple kerosene; never varies. It is the one available trusty in the grimy hands of furnace men, hardeners, carburizers, and is also being universally adopted by colleges owing to the correctness of the principle utilized. Our best customers are those who have tried all other means of heat measuring.



The
Pyroscope
in use.

Send for Our Free Circular P.

SHORE INSTRUMENT & MFG. CO., INC.

555-557 West 22nd St. New York
Agents in all Foreign Countries.

Sole Agents:
The A. R. Williams Machinery Co., Limited
Toronto, Canada



M.E.C. Products

are living up to the
Industrial Slogan—

“Efficiency and
Greater Production”

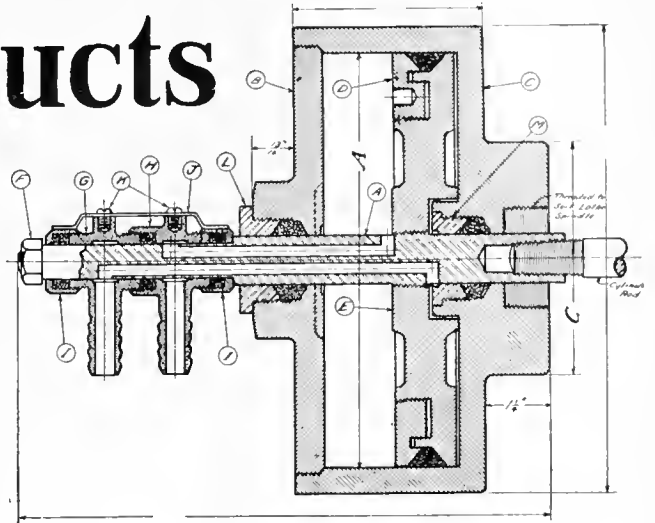

There is a well-justified demand for labor-saving equipment—and the demand will increase as the weeks go by, therefore—Now is the right time to place your orders for M.E.C. Labor-saving Equipment.

The M.E.C. Air Cylinder, for instance, speeds up production materially, improves its quality—and creates a greater manufacturing economy. That is why it is popular with every munition plant, automobile factory, gas engine builder, and wherever a greater and more economical production is the serious problem. The M.E.C. Air Cylinder is the very essence of simplicity.

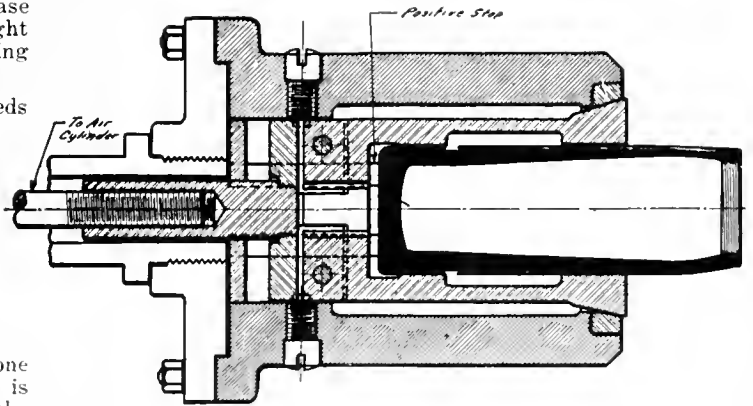

In Style “D” shown herewith—an absolutely perfect metal to metal seat is effected because the head is screwed in as one solid piece. Adjusting packing ring or piston is only a few minutes’ job—operator unscrews the head—gives the piston ring one or two turns—puts back and screws in the head in a second or two and he is ready for further operation—nothing could be simpler or quicker.

It is especially adapted for special chucks or fixtures requiring operation in either direction.

M.E.C. Air Operated Hinged Collet Chucks Are Recommended By The Leading Chuck Users Everywhere.

They grip uniformly and instantly and do not mar the work in the slightest degree. It does away with the wrench and all its attending lost motion. A turn of the air valve operates jaws. It has the record of increasing output from 50 to 90 per cent. Get our catalog on full line of M.E.C. Labor-Saving Devices: two-jaw and three-jaw chucks, air operated expanding mandrels and collapsible taps. Fill in coupon and send to-day.



Manufacturers Equipment Co.

175-177 N. Jefferson St., Chicago, Ill.

New York Office: 30 Church Street

Agents for Central and Eastern States and Canada: J. R. Stone Tool & Supply Co., Goebel Bldg., Detroit, Mich.

Foreign Agents: C. W. Burton, Griffiths & Co., Ludgate, Ludgate Square, London, England

Gentlemen:—Please send me copy of your catalog entitled “Labor Saving Devices,” according to your advertisement in Canadian Machinery.

Name

Address

Position

With

If any advertisement interests you, tear it out now and place with letters to be answered.

The Munitions Worker's Grinder



The cut illustrates our No. 7 "LITTLE DAVID" Grinder, fitted with 21" Extension Shaft, housing and outer bearing. The grinding wheel is 6" x 1", of composition suited to the work, and its free speed is 3,000 r.p.m. Weight, 24 lbs.

This style of Grinder is just what you need for grinding the insides of High Explosive Shells, or any work where grinding, buffing, or touching up is to be done.

They are widely used in munitions plants, because they are **convenient**, **efficient** and **time-saving**. We use them in our own munitions work, and can tell you how to apply them to the best advantage. Ask our nearest branch for information and prices.

CANADIAN INGERSOLL-RAND CO., LIMITED

COMMERCIAL UNION BUILDING - MONTREAL, CANADA

SYDNEY TORONTO COBALT TIMMINS WINNIPEG NELSON VANCOUVER

Works: Sherbrooke, Que.

Barkey

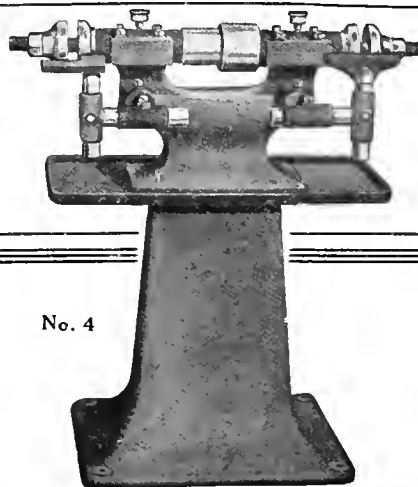

Grinders

No. 4



No. 1

Strength, durability and speed describe these machines. Strength right where it is needed—in the spindle and bearings. The knowledge of years of experience has gone right into the making and our many clients throughout the country will testify as to their value.

No. 1 is an Emery Column Grinder very popular where speed and quality are desired. It can be fitted up with our special skate attachment which adds to its usefulness.

No. 4 Emery Grinder is built to meet the requirements of car, foundry, machine and plow shop uses. Its speed makes it a valuable asset wherever installed.

The economic operation of your shop will be made more economic by the installation of "Barkey Grinders." Inquiries will be promptly attend to.

Barkey Bros.

STOUFFVILLE, ONT.



“REXITE”

(CORUNDUM) *كروندوم*

“Rexite” Wheels for Grinding Shrapnel and High Explosive Shells

“Rexite” is an electric furnace product, and is produced from Bauxite which mineral is the purest form of Alumina found in Nature. Analysis shows about 96% Alumina.

CRESOLITE

For Grinding Gray Iron Castings, Chilled Iron, Brass, Marble, Granite and Pearl

We have adopted a material called Cresolite, which is Carbide of Silicon in crystalline form. Hardness and brittleness is a characteristic feature.

Our wheels are made under the guidance of over thirty five years' experience. You'll find them invaluable because they INCREASE PRODUCTION AND LOWER COSTS.

CANADIAN HART WHEELS, Ltd.

Manufacturers of Grinding Wheels and Machinery

Hamilton, Canada

Write our service department for information concerning your grinding needs

If any advertisement interests you, tear it out now and place with letters to be answered.

*A Page From a
Carborundum
Service Man's
Note Book says:*

*"Our Customer Considers
this an Extraordinarily
Good Performance"*

The job is grinding, rough from the sand, chilled iron rolls on a Landis special grinder. The rolls are 32 inches long, $16\frac{7}{16}$ inches in diameter and $\frac{7}{16}$ stock is removed. It takes the Carborundum Wheel, 24 grit, L grade, G 3 + bond just $4\frac{3}{4}$ hours to do the work.

☞ The finish is uniform, the wheel cuts clean and it loses but $\frac{1}{15}$ of an inch.

☞ It is the unbeatable grinding combination that gets these results. —The right wheel, Carborundum service and a good grinding machine.

What can this service do for you?



THE CARBORUNDUM COMPANY
NIAGARA FALLS, N. Y.

NEW YORK CHICAGO PHILADELPHIA CLEVELAND CINCINNATI BOSTON PITTSBURGH
MILWAUKEE GRAND RAPIDS

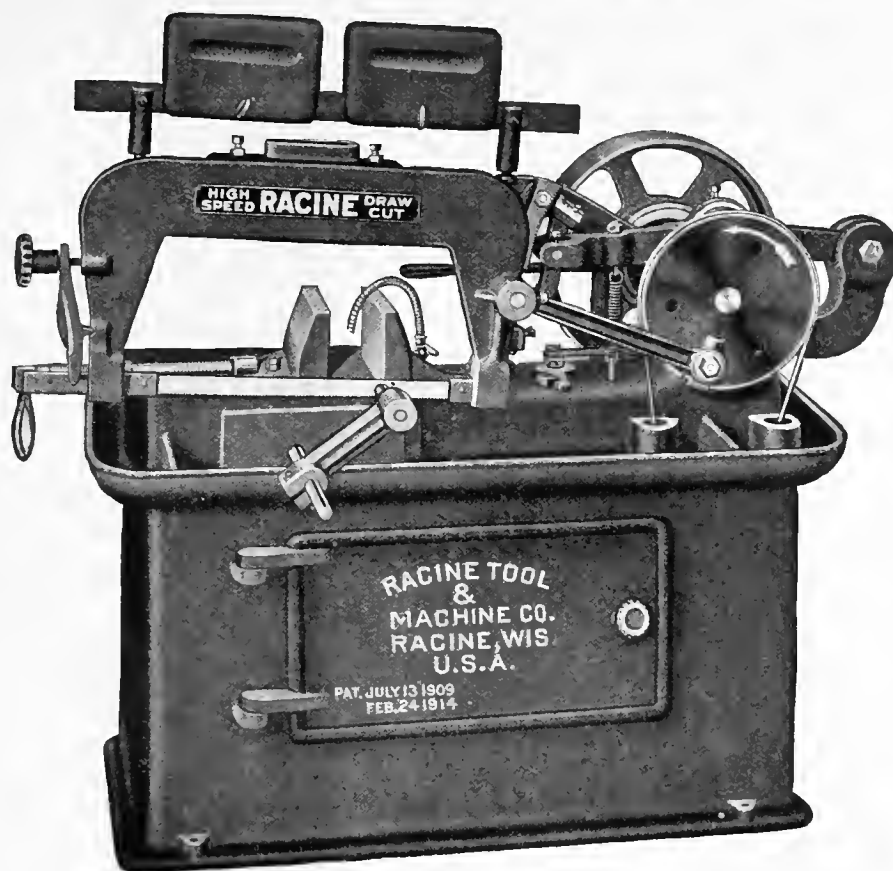

RACINE High-Speed Metal Cutting Machines

The **RACINE** is the original high-speed draw-cut metal-cutting machine, noted the world over for its simplicity and rigid construction.

The **RACINE** has faithfully met all requirements for metal cutting in the past ten years throughout the world, both in regular work and in hundreds of munition factories.

The **RACINE** requires no skilled labor to operate it.

Order a **RACINE** from your dealer, understanding that we endorse any fair proposition the dealer makes you, as we fully guarantee our machines in every particular.

The **RACINE** wears the badge of honor for loyalty and faithful performance of the work allotted to it behind the trenches.

Write for Catalogue to-day.

Racine Tool & Machine Company
RACINE, WIS., U.S.A.

SMOOTH AS GLASS

That's the kind of grinding you want
That's the kind you get

WITH THE
Dominion Universal Grinder

ADD TO THIS

Ease of Operation, Stability and Solidity
of the Machine makes it a
Master Grinder

Try One and See. You may pay more,
but you cannot get a better grinder

LET US TELL YOU

MORE
ABOUT IT

**Dominion
Machinery
Company**

110 Church St.
TORONTO, ONT.
CANADA

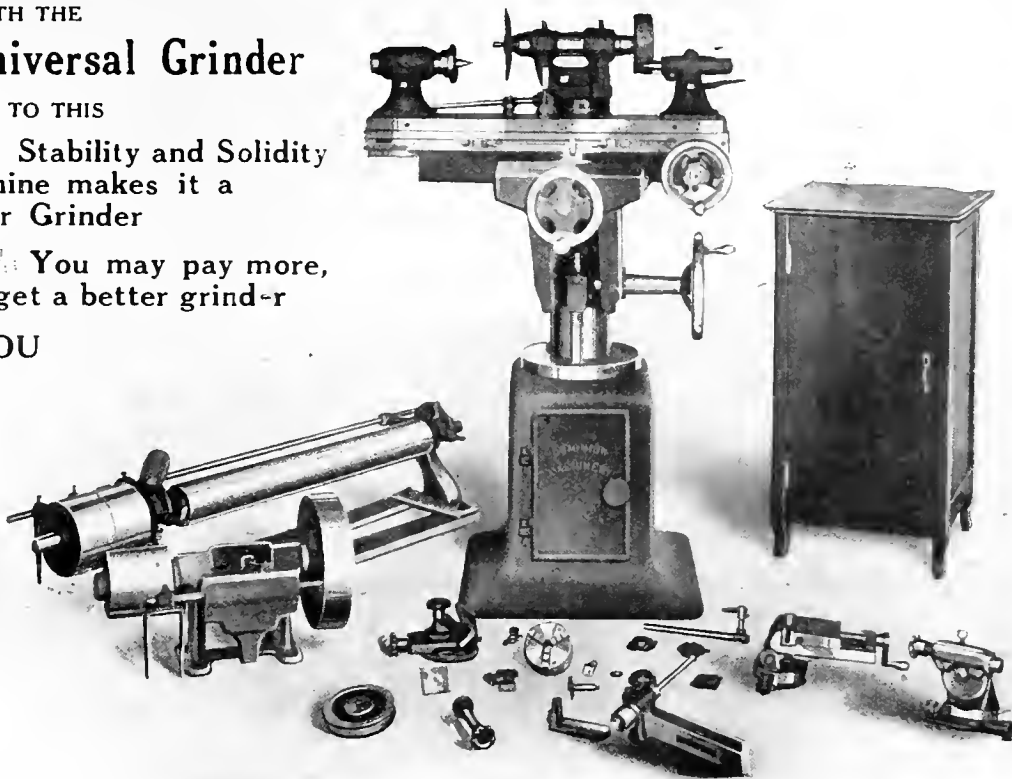

Stow Shell Grinders Increase Production



Suspended
Pedestal
Mounted
on Truck

Any Size
Any Current

Immediate
Shipment

Stow Manufacturing Co.

Binghamton, New York, U.S.A.

Oldest Portable Tool Manufacturers in America



UNIVERSAL Electric Drills

Licensed Under Burke
Universal Motor Patent

The only Portable Electric Tools made
that are equipped throughout with ball
and roller bearings. Made with aluminum
cylinder, insuring extreme lightness and a
powerful specially constructed motor result-
ing in increased capacity. Can be furn-
ished with Universal, Alternating or
Direct current motor 110 or 220 volts.

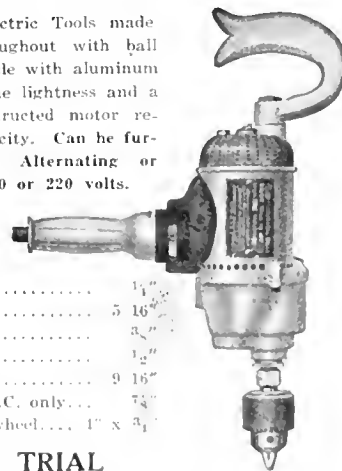

000 Drilling Capacity	1 1/4"
00 " "	5 16"
0 " "	3/4"
01 " "	1 1/2"
1 " "	9 16"
2 " "	D.C. only	7/8"
No. 6 Electric Grinder, wheel	1" x 3/4"

SHIPPED ON TRIAL

**Independent Pneumatic Tool
Company**

Office: 334 St. James Street, MONTREAL, QUE.

Toronto: 32 Front St. W. Winnipeg: 123 Bannatyne Ave., E.
Vancouver: 1142 Homer Street

If any advertisement interests you, tear it out now and place with letters to be answered.

Your Grinding Concerns You Only

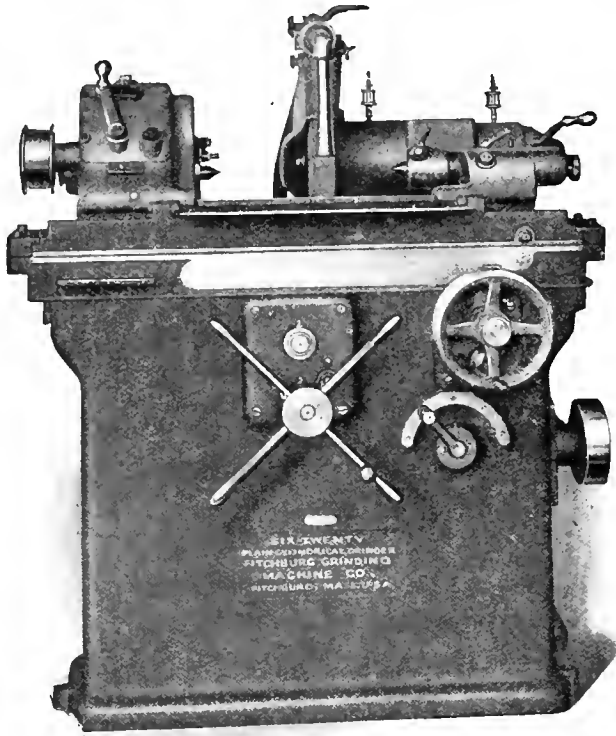

MODEL B

Examples of the wonderful results obtained by our users would not benefit you. Your difficulties may be entirely different, and it is these "different" problems that the Fitchburg shows to advantage.

Model "B" shown here is thoroughly efficient—and the large pilot wheel on the traverse table is especially convenient and allows for greater speed. It is made for grinding short, cylindrical pieces. Your work may not be of this nature. Write us and secure our co-operation.

If Quality is Concerned—so is "Fitchburg"

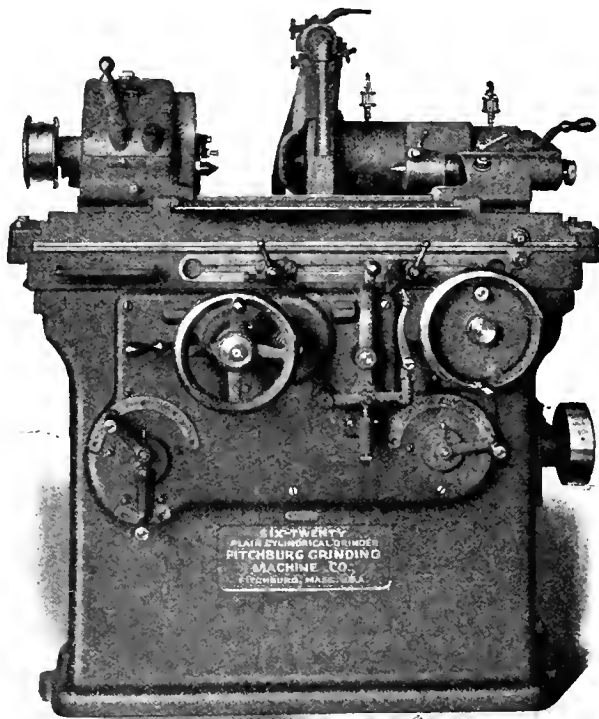

MODEL A

Both Models are equipped for straight or taper shaft grinding and the difference in the machine is that the Model A is arranged with power feeds and the Model B is hand operated.

Constructed on the unit system, each unit may easily be removed from the machines. Lubricating features reduce wear and friction to a minimum.

Specifications and full information gladly furnished.

Fitchburg Grinding Machine Company

FITCHBURG, MASS., U.S.A.

WHY TOLERATE

TROUBLE

in YOUR Grinding Department ?

Eliminate all difficulties by using High-Grade Selected

DIAMONDS

Direct from the South African Diamond Fields. All sizes at your command, either unmounted or mounted in any style holder, **MADE IN CANADA.**

Try our **CAST STEEL** mounting for complete satisfaction of performance.

Wheel Trueing Tool Company

88 West Pitt Street

WINDSOR, ONTARIO



Pliers, Structural Wrenches, Track Wrenches, Machine Wrenches, Eye Bolts, Lathe Dogs, Journal Box Wedges, Etc.

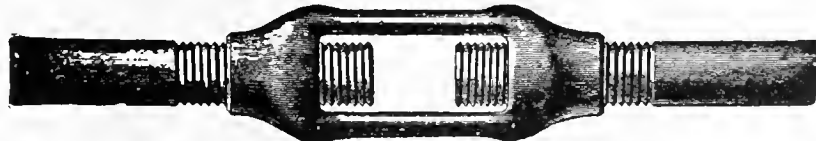

All Kinds Of Special Drop Forgings

Send Models or Blue Prints for Estimates

WRITE FOR CATALOG

Canadian Billings & Spencer, Limited, Welland, Ontario

MAKE NAILS! NOT NOISE!

We offer the trade new types of

WIRE NAIL MACHINES

QUIET IN OPERATION; WITH VERY HIGH OUTPUT; ALL PARTS ACCESSIBLE; DECREASED MAINTENANCE COSTS; GREAT CAPACITY; OCCUPYING SMALL FLOOR SPACE.

Smoothly running machines, with balanced mechanical motions and no rotating cams. Built in 5 sizes, handling wire from No. 17 to 3/4" diam.

PRACTICALLY NOISELESS IN OPERATION

Sleeper & Hartley, Inc., Worcester, Mass.

CANADIAN BRANCH, COATICOOK, P.Q.

London, England, F. A. Perry, 63 Queen Victoria Street, E.C. 4. Paris, France, Edgar Bloxham, 12 Rue du Delta.

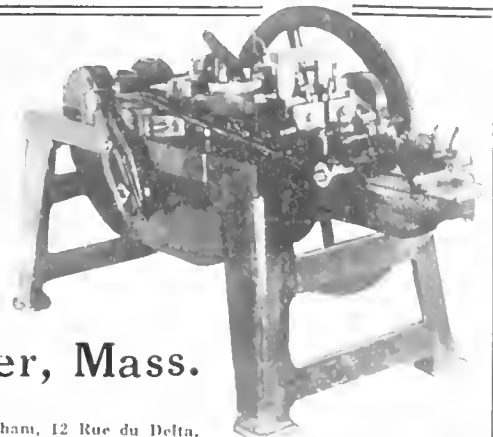

The Only Grand Prize for TOOL HOLDERS

Awarded separately and independent of other
lines exhibited at the
PANAMA-PACIFIC EXPOSITION
WAS WON BY

ARMSTRONG TOOL HOLDERS

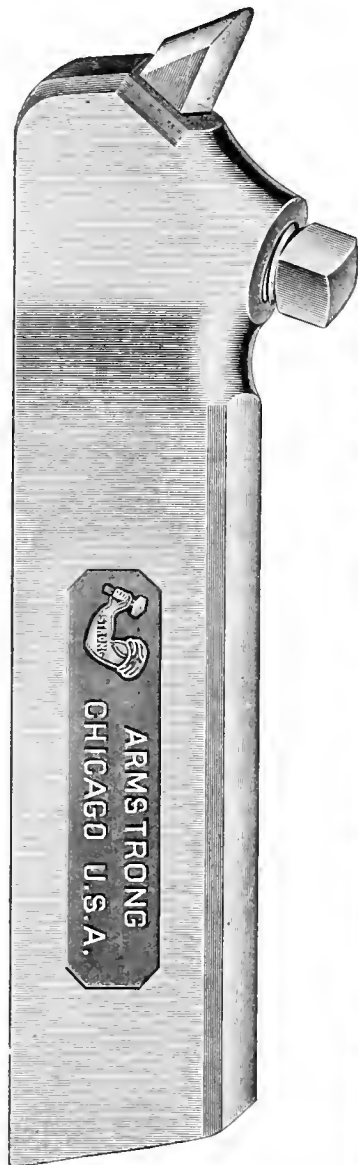

HIGHEST AWARD

at 4 World's Exposition
Paris - - - 1900
St. Louis - - 1904
Liege - - - 1905
San Francisco 1915

THEY ALWAYS
MAKE GOOD



They Are Saving Millions of
Dollars in High Speed Steel

CATALOG FREE



Armstrong Bros. Tool Co.
"The Tool Holder People"
306 N. Francisco Ave., CHICAGO, U.S.A.

The Panama-Pacific MEDAL OF HONOR was also won by
ARMSTRONG Drop Forged Wrenches, Ratchets,
Clamps, Lathe Dogs, Etc.

LOOK AT YOUR FILES

Test the balance of them.
See how hard they are. Run
your finger over the teeth
and note their sharpness and
regularity.

These qualities of the
"Famous Five" Files were
not arrived at by accident.

They are the result of expert
knowledge of the exact needs
of every trade. This know-
ledge has helped us to
standardize the merits of
"Famous Five" Files in the
minds of every user.

*Specify them when
ordering*

They are:

**KEARNEY & FOOT
GREAT WESTERN
AMERICAN
ARCADE
GLOBE**

Made in Canada by



NICHOLSON FILE CO.
PORT HOPE
ONTARIO

DUMORE

**PORTABLE
ELECTRIC**

GRINDERS



Short-cuts count these days—it doesn't pay to use inefficient equipment and wasteful methods in handling your grinding jobs. Check up this work and see how much time you spend in grinding gauges. Two or three hours on a job in many cases—jobs that the DUMORE Grinder would handle in twenty or thirty minutes. No need to lap out your gauges when you use the DUMORE—it turns out finished work. Its exceptional speed prevents the wheels from breaking down and insures extreme accuracy, free from chatter marks. Used by hundreds of manufacturers for grinding gauges, tools and dies. Operates on either direct or alternating current. Specify which equipment you need and we will ship on approval. State voltage of your current. Literature on request.

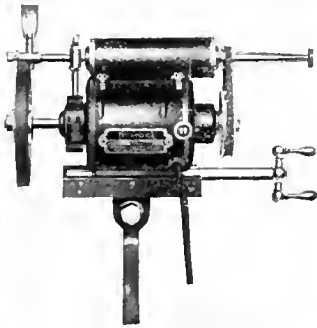

Equipment A

Includes High Speed Internal Spindle A. Reach 3". Speed, 30,000 R.P.M. Motor spindle speed, 10,000 R.P.M. Set of seven wheels, 3/8", 7/16", 9/16", 11/16", 13/16" (for internal work), 2 1/2" and 4" (for external work). Six Rubber Belts. Cutter Grinder Rest. Cross Feed Lever. Cord and Plug. Hardwood Carrying Case. Net weight, 17 lbs. Shipping weight, 30 lbs.

FOR AVERAGE TOOL ROOM USE

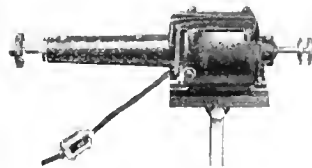

Equipment B

Includes Extension Arm B. Reach 10". Speed, 10,000 R.P.M. The Extension Arm B is interchangeable with Internal Spindle shown on Equipment A. Two Elastic Wheels, 2 1/2" and 4". Cutter Grinder Rest. Cross Feed Lever. Cord and Plug. Hardwood Carrying Case. Net weight, 19 lbs. Shipping weight, 32 lbs.

FOR DEEP INTERNAL WORK

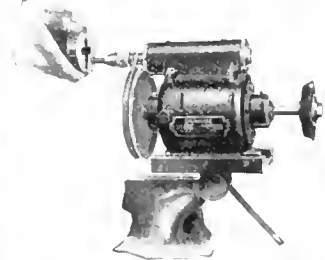

Equipment C

Grinder complete with special spindle and chuck for grinding button dies. Speed, 50,000 R. P. M. This special spindle can be furnished to manufacturers who already have Equipment A or B. Outfit also includes 3/8" Rd. Emery Pencil, 2 1/2" and 4" Elastic Wheels. Cutter Grinder Rest. Cross Feed Lever. Cord and plug packed in substantial carrying case. Net weight 17 lbs. Shipping weight, 30 lbs.

BUTTON DIE GRINDER, 50000 R.P.M.

Wisconsin Electric Co., 1712 Dumore Bldg., Racine, Wis.

Sold in England by **CANADIAN-AMERICAN CO., LTD., 8 Bouverie St., London, E.C., Eng.**

If any advertisement interests you, tear it out now and place with letters to be answered.



Quality Quantity

Guaranteed

Write US About Your
Acetylene Supply

Commercial Acetylene Welding Co., Inc.

ATLANTA, GA.
AURORA, ILL.
BOSTON, MASS.
BOUND BROOK, N.J.
EAST DEERFIELD, MASS.

103 Bay Street, Toronto

TORONTO, ONT.
SAN FRANCISCO, CALIF.
MOBERLY, MO.
W. BERKELEY, CALIF.

Main Office
80 Broadway, New York

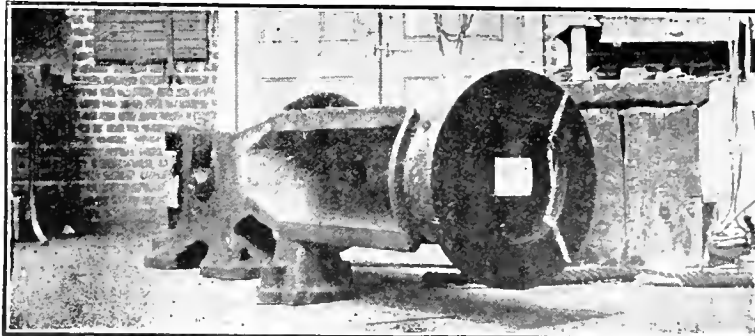

Broken Engine Cylinder—PERFECTLY RECLAIMED by WELDING
in short time and at low cost. (See white line.)

Oxy-Acetylene Welding and Cutting Plants
will save and make you money in repairs or
manufacturing. They have done it for
others.

Oxygen—pure, efficient, safe, low-priced.
Pure Dissolved Acetylene.

Ask for more information—DO IT NOW— →
Use THIS COUPON, please

A Big Loss Prevented

The cost of a new cylinder was
saved by the use of

**OXY-ACETYLENE
WELDING Process**

L'AIR LIQUIDE SOCIETY

—Three Canadian Distributing Stations—
30 Boler St. Maisonneuve 325 William Ave.
WEST TORONTO MONTREAL WINNIPEG
—Branches the World Over—

L'Air Liquide Society, Maisonneuve,
MONTREAL, P.Q.

Gentlemen,—Will you please send, without obligation
to me, postpaid, your New Booklet?

Name

Address

Province Date

Business

C.M.

Mention this paper when writing advertisers. It will identify the proposition about which you require information.

Not since the British North America Act created the Dominion of Canada, has any process or invention so reduced the cost of manufacturing sheet metal articles as the process of

Electric Spot Welding

We manufacture a full line of machines for every purpose. Send us a sample or a sketch of your work, get our report and recommendations. The figures will startle you, and you will want to install a machine to increase your output and profit.

The Winfield Electric
Welding Machine Co.

WARREN, OHIO

- U.S.A.

GARVIN

NO. 12 PLAIN MILLING MACHINE FOR ALL LIGHT MANUFACTURING

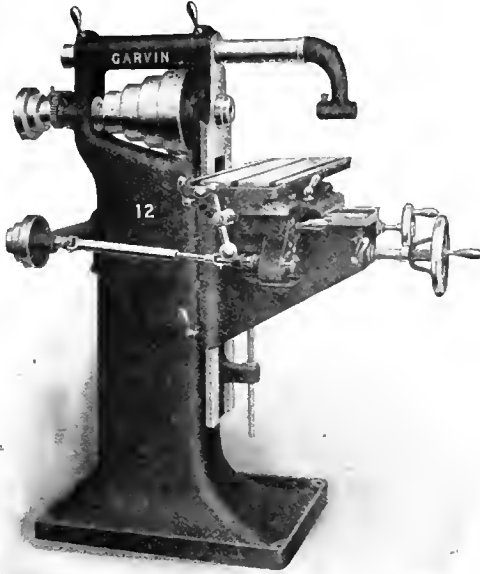

This machine is built especially strong and substantial for a tool of its capacity, and has many valuable features worthy of special mention. The slide is fitted with a quick pitch screw, giving one inch per turn. This combines the rapidity of a rack feed with the steadiness of the screw feed. The table has an oil pan all around it, with finished edges—automatic feed, trip and reverse—adjustable nut on the feed screw to take wear—the Feed Screw is hardened.

Adjustments.....18 x 6 x 15 in.

For Further Information { ASK YOUR DEALER
or WRITE US DIRECT

IMMEDIATE DELIVERIES

Send for Complete Catalog

No. 12 Plain Milling Machine—Use Code Abrade

Manufactured by

THE GARVIN MACHINE COMPANY
Spring and Varick Streets (Visitors Welcome) 50 Years New York City

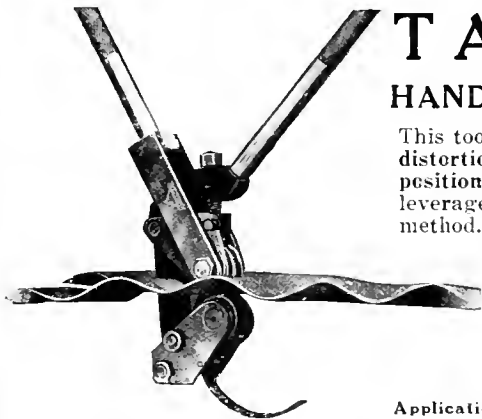

TANGENT Self-Feeding, Non-Distorting HAND TOOL FOR CUTTING CORRUGATED SHEETS

This tool will cut sheets on any angle, limited curves and through the centre with no distortion of cut edges. Sheets can be cut to required shape when being fixed in position on the job. Made in two styles, for 20 swg. (weight 5 lbs.), with compound leverage for 18 swg. (weight 6½ lbs.). Cuts 100% faster than any other hand method.

Write for Illustrated Pamphlet and Prices.

Montgomery, Smith & Co., Limited

Patentees and Manufacturers

Tangent Works, Keynsham, Somerset, England

Applications for selling agencies or rights to manufacture under license will be considered.

Don't Crowd Your Large Machines

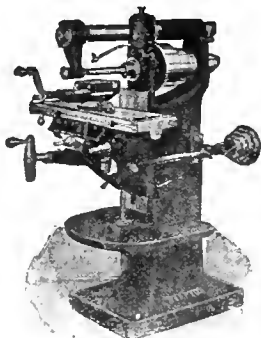

You cannot manufacture small parts economically on a large machine. Steptoe Small Power Feed Millers and Hand Millers are especially adapted for that kind of work, a stiff, heavy tool that can be quickly handled and crowded to the limit. That is the machine to buy for small parts.

If your Planers are crowded take the small jobs and put them on a Steptoe Shaper and you will do them quicker and you will have less money invested in equipment.

STEPTOE SHAPERS "Just a Little Better."

CIRCULAR ON REQUEST.

John Steptoe Co., Cumminsville, Cincinnati, Ohio, U.S.A.

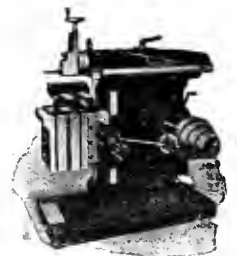



The Ford-Smith Miller

Two Sizes, all Gear Feeds { No. 2—24" x 7½" x 19"
 No. 3—34" x 10" x 20"

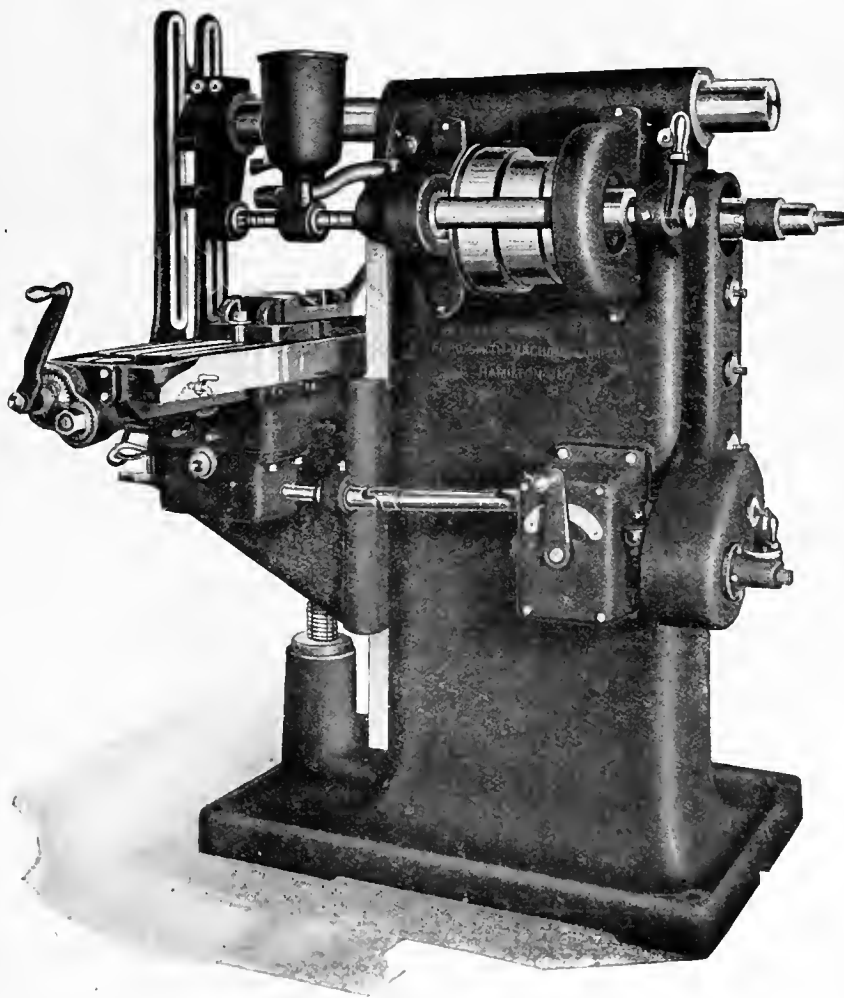

These machines are designed for easy operation, built of the very best materials, and the workmanship is of the highest grade throughout.

The whole organization of this firm, including most of our men, are machine tool men only, and we are producing Milling Machines that mark a higher notch in Canadian Machine Tool Manufacture.

We want to keep you posted in our advances along these lines. Will you send us your name to-day, not with the idea of bothering you with letters, but so that we can see that the literature we get out from time to time, is mailed to you.

The Ford-Smith Machine Company, Limited
 HAMILTON, CANADA

If any advertisement interests you, tear it out now and place with letters to be answered.

You can multiply
your
Threading Production
with a
**Chicago
Semi-Auto
Threader**

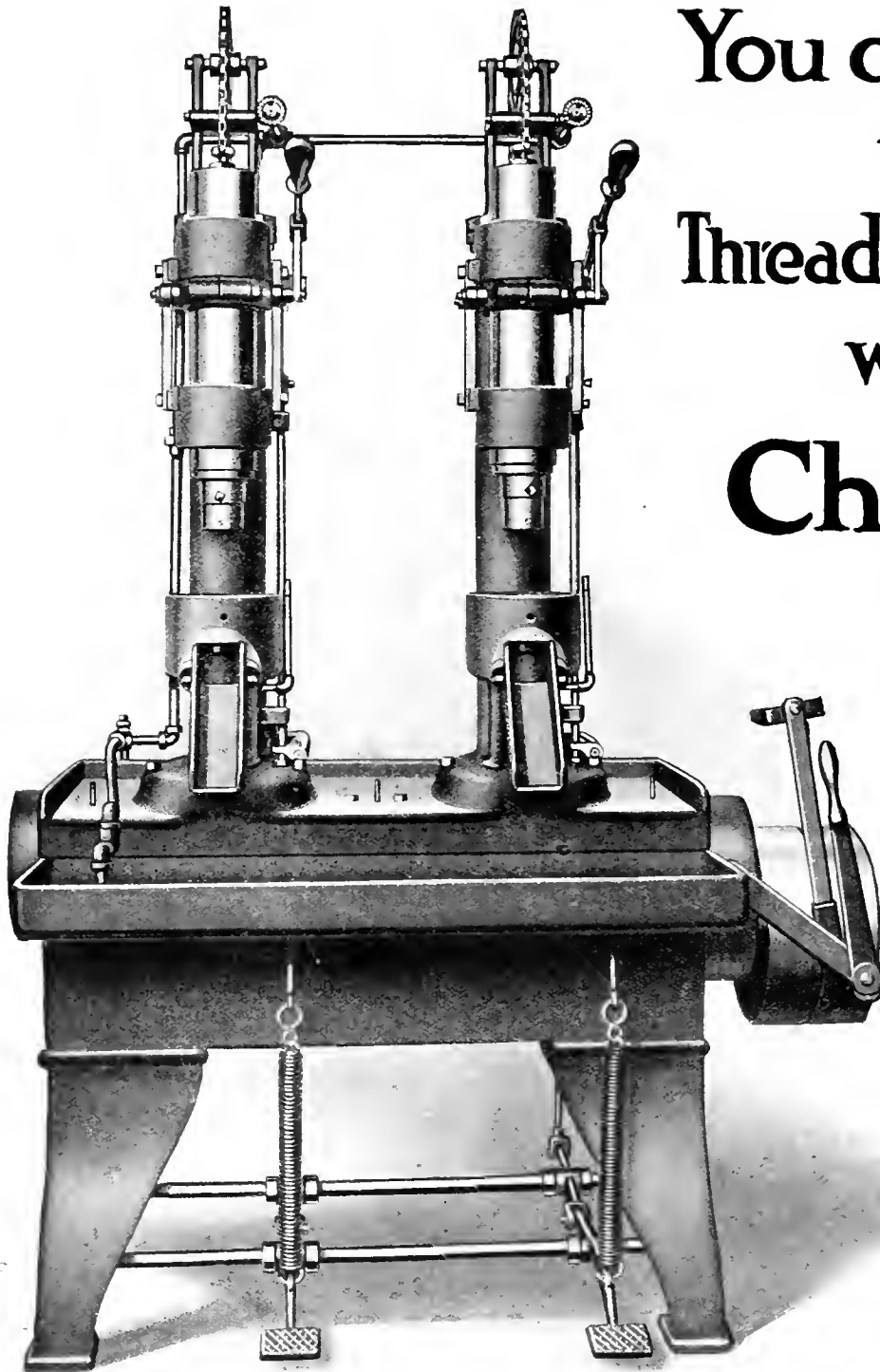

THE threading of studs, screws, spark plugs and work of similar character can be produced better and faster on Chicago Semi-Automatic Threaders. Here's why. The basic principle—vertical spindles and stationery dies used on this machine permit higher cutting speeds, perfect lubrication and more accurate counter balancing to prevent marring and tearing of threads.

The holders with sockets cut to carry work with irregular shaped ends are used, instead of chucks—eliminating

the time usually required to properly secure the work. The lubrication system is most efficient. Oil is carried, directly down in volumes through the heads and the dies themselves—keeping the tools cooler than otherwise possible and at the same time carrying away all chips.

Its capacity is from $\frac{1}{4}$ in. to $\frac{3}{4}$ in. U.S.S., and up to 5 in. in length.

Write us to-day for bulletin No. 4, which describes the machine completely.

John Macnab Machinery Company
90 West Street, New York City

Mention this paper when writing advertisers. It will identify the proposition about which you require information.

Bilton Automatic Gear Millers—Spur or Bevel Gears

CAPACITY

- No. 1 - - 14 Pitch
- No. 2 - - 10 Pitch
- No. 3 - - 8 Pitch

The Bilton Machine Tool Company

Succeeding The Standard Mfg. Company
 Housatonic Ave., Bridgeport,
 Conn., U.S.A.

Also Manufacturers of —
 Plain Horizontal Millers
 Automatic Millers
 Plain and Ball Bearing
 Bench and Column Drills
 Riveting Machines
 Milling Cutters

Catalog 30 on request.

Foreign Agents:

Alfred Herbert, Limited
 M. Mett Engineering Company
 Chas. Churchill Company, Limited

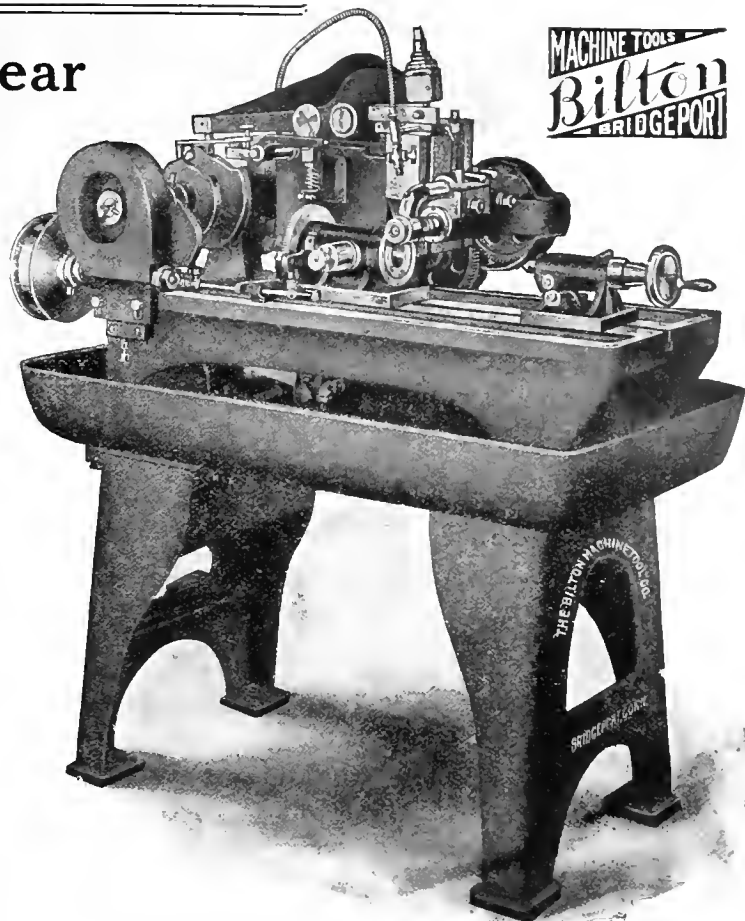

For Rapid Production and Accurate Work

USE THE "BRIGGS"

The Briggs Miller handles work no other machine of its size can touch. It is a manufacturing machine. On account of its rigid construction it will produce accurate work when running at a high rate of speed and feed.

The Base Tank and Large Gear Pump is the latest addition to its many advantages. Tank holds 20 gallons of cutting lubricant

Pump never requires priming and will deliver ten gallons per minute to the cutters, keeping them cool when run at very high speed.

Our booklet describes fully. Drop a card for it.

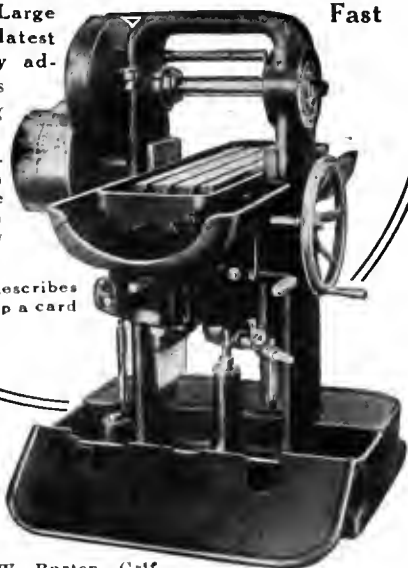

Gooley & Edlund
 Inc.
 Cortland, N.Y., U.S.A

Foreign Agents: Allied America, France, Belgium, Italy, Switzerland, Machinery Company of Russia, Scandinavia, C. W. Burton, Griffiths & Co., London, Manchester and Glasgow, Barandiaran, Mettler, Gazeau & Cie, San Sebastian, Spain.

Did you know that every part of every SMART-TURNER PUMP is Made-in-Canada?

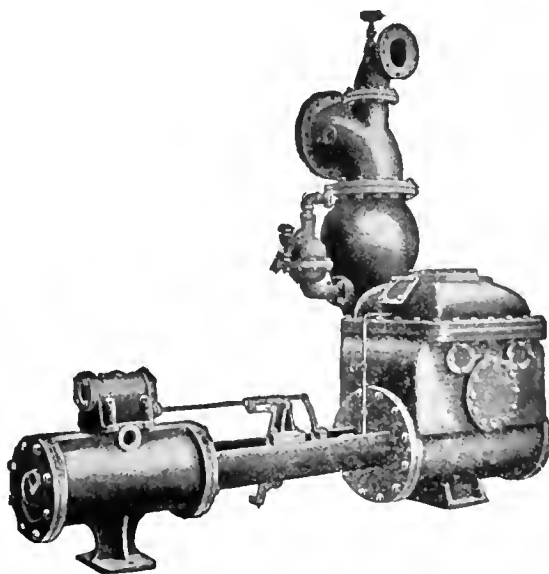

KEEP YOUR DOLLARS AT HOME.
 The Smart-Turner Machine Co., Limited
 HAMILTON, CANADA

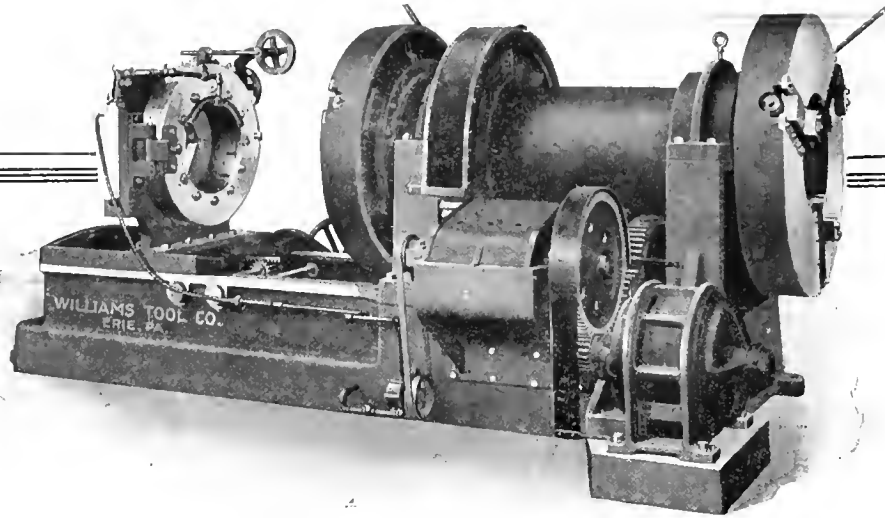

To Obtain Quality Use "Williams" Pipe Cutting and Threading Machine

Williams Tool Company

Erie Penn. U.S.A.

Canadian Agents:
The A. R. Williams Machinery Company, Limited
Toronto, Canada

Foreign Agents:
Universal Machinery Corp., London, England

Whether on exposition or in practical use, this machine will always prove its superiority. At the Panama Exposition the Williams carried off the highest honors. That was the final decree of men who knew machinery from different angles—quantity of production, quality of production, greatest economy and convenience. Think that over. We don't charge you for winning those honors. Let us send you full information.

Scrap Metals

Scrap Iron, Steel and Metals

No undertaking is too large for us. We are Scrap Metal Specialists, and can co-operate with you in the dismantling of railway equipment, bridges, plants, steamers, mills and will take your rails and machinery.

Shell Makers. We can take care of all your scrap materials, at highest prices.

Give us particulars and we will relieve you of all worry.

Dominion Iron & Wrecking Co.

Transportation Bldg.

General Offices:

Quebec, Que.

LIMITED
Montreal, Quebec

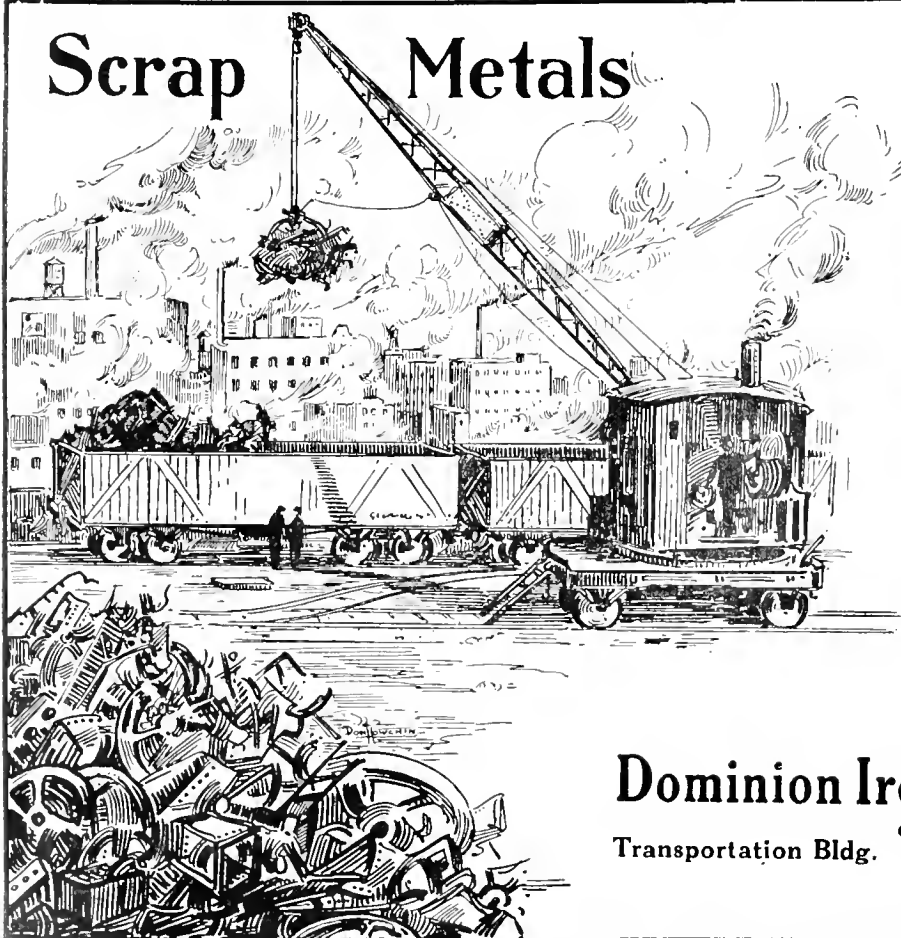

Mention this paper when writing advertisers. It will identify the proposition about which you require information.



Heating, Ventilating, Drying

Winnipeg Office:
Messrs. Walkers
Limited
259 Stanley Street.

Calgary and Edmonton
Offices:
Messrs. Gorman,
Clancey & Grindley,
Limited

Montreal Office:
412 St. James St.

After severe and thorough tests Keith fans have been adopted by the British Admiralty for ventilating and forced draft purposes for its fighting ships. United States and other naval powers also use Keith fans. Why? Because they are the most efficient and most rigidly built fan that can be obtained.

The blades are so shaped and formed as to admit of the handling of the largest volumes of air at uniform pressure over the entire width of the fan wheel.

Superior workmanship and material form the foundation of our success.

Catalogues sent on request.

Sheldons Limited
Galt Ontario

Vancouver Office:
Robt. Hamilton &
Company
Bank of Ottawa
Building

Toronto Office:
505 Kent Building

If any advertisement interests you, tear it out now and place with letters to be answered.

Read the Descriptions—Study the Illustrations

**Then Consult us --
We will Co-operate
with you.**

To us that would be an ideal situation—co-operating with you. We can give you such service that our co-operation would help us both.

The Cataract Quick Change Precision Lathe

Length of Bed 52"
Total Length of Lathe 65"
Distance Between Centres 28"
Swing 9" and 15"
Swing over Carriage... 5½" and 11½"
Diameter of Lead Screw... 1" x 6 pitch
Diameter of Front Cover..... 2 1-32"
1 Diameter of Rear Bearing..... 1¼"
Length of Spindle 15"
Hole through Spindle 1¼"
Draw-in Chuck Cap..... 1" maximum

From the above specifications you will observe that it is ideally designed for ordinary or specially fine work. Study the illustration and then write us for further information.

Cataract Tool Post Lathe

An ideal machine for fine work. Especially adapted for optical work or any series of work where operations such as turning, boring and recessing, also internal and external threading, must be done in one setting.

Six tools in turret independently adjustable.

Additional tailstock, turret or other standard attachments allowable.

Will take round stock ½", ¾", 1", 1½" and 1 11-16". In ordering kindly mention chuck capacity desired.

One horse-power required. Supplied with or without motor drive.

Catalogue No. 15 is ready to mail to you to-day. Write for it to-day.

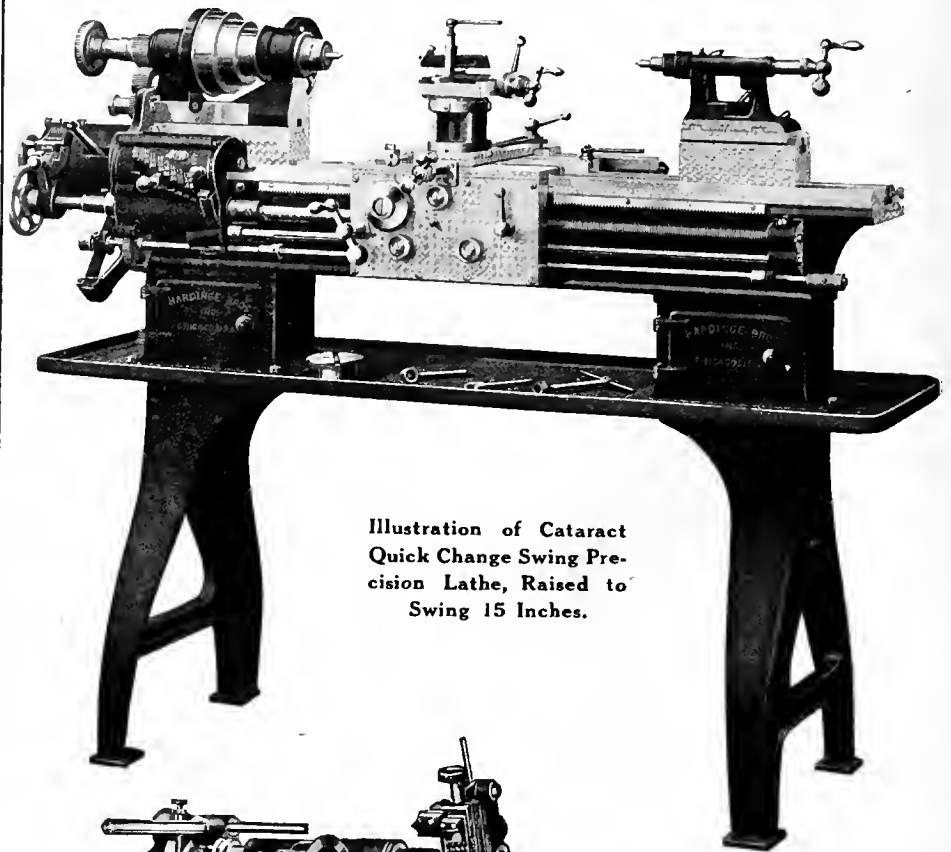

Illustration of Cataract
Quick Change Swing Pre-
cision Lathe, Raised to
Swing 15 Inches.



Cataract Turret
Tool Post Lathe.

Hardinge Bros.

1770 Berteau Ave., Chicago, Ill., U.S.A.

THREAD MILLERS

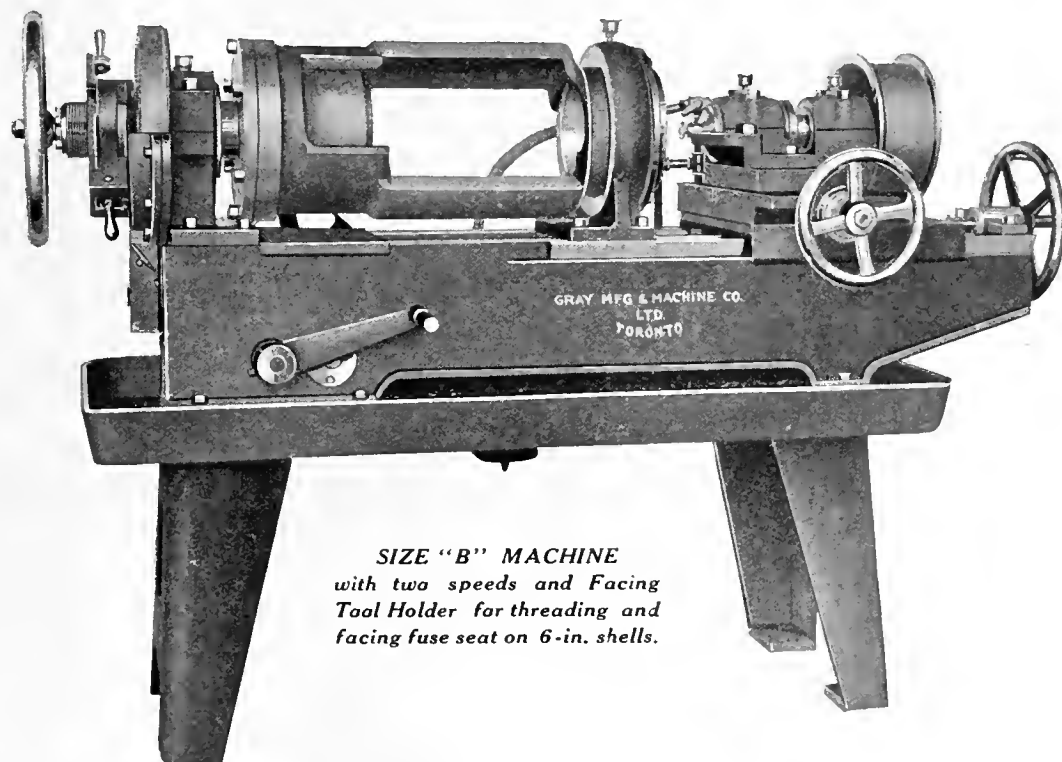

*SIZE "B" MACHINE
with two speeds and Facing
Tool Holder for threading and
facing fuse seat on 6-in. shells.*

Gray's Guarantee

that their **THREAD MILLERS** will **MILL THREADS** to **SIZE**, and **TRUE UP FUSE SEAT**, thus eliminating hand tapping and hand seating, and also guarantee a stated production.

Size "A" Machine handles Shells from 3-in. to 5-in.

Size "C" Machine handles 8-in. and 9.2 in. Shells and Adapters.

Thread Millers for Fuses and any line of manufacturing work.

PROMPT DELIVERIES

THE GRAY MFG. & MACHINE CO., LIMITED
686-692 St. Clarens Avenue
TORONTO, CANADA

If any advertisement interests you, tear it out now and place with letters to be answered.



IN STOCK READY TO SHIP
"STAR BRAND"
SEAMLESS BRASS
CONDENSER TUBES

TINNED INSIDE AND OUTSIDE

$\frac{5}{8}$ and $\frac{3}{4}$ inch O.D., No. 18 Stubs Gauge—12, 14, 16, 18 and 20 foot lengths

—AND—

"STAR BRAND" BRASS CONDENSER TUBE FERRULES

Standard 14 Thread for $\frac{5}{8}$ and $\frac{3}{4}$ in. Tubes

OUR STOCK ON HAND READY FOR IMMEDIATE SHIPMENT ALSO INCLUDES A FULL LINE OF REGULAR STOCK SIZES AND SHAPES OF THE FOLLOWING

"STAR BRAND" SPECIALTIES

Seamless Brass and Copper Pipe and Tubing, Brass Fittings, Sheet Copper, Copper Bar, Rods and Wire, Copper Nails, Sheet Brass, Brass Rods, Tobin Bronze Rods, Copper Rivets and Burs AND OTHER PRODUCTS IN BRASS, COPPER, PHOSPHOR BRONZE, ARCHITECTURAL BRONZE, ETC., ETC.

U. T. HUNGERFORD BRASS & COPPER CO.

BRANCHES:
 BOSTON
 BALTIMORE
 PHILADELPHIA
 SAN FRANCISCO

HUNGERFORD BUILDING
 Lafayette, White and Franklin Sts.
 NEW YORK, U.S.A.

KINDLY ADDRESS
 INQUIRIES
 FOR ATTENTION OF
 DEPARTMENT D.



Convenience
Quality=====

Keystone tools bear the stamp of quality that makes them to be desired because they are made in the most convenient shapes and give the maximum in service and economy.

Our ratchets and adjustable wrench illustrated here are samples of our line. The Keystone brand are carried by the best houses. Inquire of your dealer.

The Keystone Mfg. Co.
 BUFFALO N. Y. U. S. A.



BROWN'S

**Brass,
Bronze,
Gilding Metal**

*In Sheets, Rolls, Plates
and Rods*

**Brown's Copper & Brass Rolling
Mills, Limited**

General Offices and Works,
New Toronto, Ontario, Canada



If any advertisement interests you, let us hear from you by mail or telephone.

D. K. McLaren's

GENUINE BRITISH-OAK TANNED

LEATHER

BELTING

TRADE

MARK

More for Your Money

D. K. McLAREN'S BELTING has "made good" in so many instances that it is pretty safe to say that it gives you more for your money than the belting you are now using.

If you are noticeably losing time through slippage and breakage it is not probable, but CERTAIN, that D. K. McLAREN'S BELTING will give you more for your money; for this **GENUINE BRITISH OAK-TANNED PRODUCT** gives all the efficiency within the range of possibility, or, in other words, all belts must slip a little and break sooner or later, BUT McLaren's is a minimum slipper and a minimum breaker.

Our time-tested British Oak tanning process assures strength, durability and pliability to all our belts.

Let us put you in touch with some users of our belts.
Write to-day.

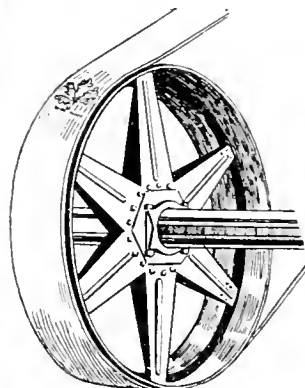

D. K. McLAREN
LIMITED



HEAD OFFICE AND FACTORY:
351 ST. JAMES STREET, MONTREAL, P.Q., CAN.

TORONTO, ONT.
194 King St. West

ST. JOHN, N.B.
90 Germain St.

VANCOUVER, B.C.
847 Beatty St.

HINTS TO BUYERS



Eliminate Danger

Accidents break down the efficiency of your organization, lead to legal troubles, loss of time and money.

TRADE MARK

BRISTO

REG. U. S. PAT. OFFICE

SAFETY SET SCREWS

insure safety. They also protect themselves because of their patented construction. The dove-tailed design of wrench and screw contracts the metal under pressure. The harder you twist the wrench the more the metal of the screw is compressed.

Write for BULLETIN 1-809

THE BRISTOL COMPANY
Waterbury, Conn., U.S.A.

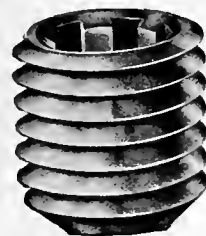

THOUSANDS of Dollars are saved every year by our clients, because we have experts who are trained to make exhaustive tests of all the material you are purchasing, whether raw material or finished products.

CANADIAN INSPECTION AND TESTING LABORATORIES, LIMITED

Head Office and Main Laboratories—MONTREAL

Branch Offices and Laboratories:

TORONTO, WINNIPEG, EDMONTON, VANCOUVER, NEW GLASGOW.

VIKING

WATERPROOF CEMENT LEATHER BELTS

Will Save You Much Money, Time, Trouble and Worry

"Viking" Belts are just in their element when in wet places and under adverse conditions.

A trial will convince you that they are all-round savers.

Write for particulars.

J. C. McLaren Belting Co., Limited, Canada
MONTREAL TORONTO WINNIPEG

STEEL CASTINGS

We are well equipped to make all kinds of steel castings, 100 lbs. to 50,000 lbs.

Dominion Steel Foundry Co.

Hamilton

LIMITED

Ontario



IS YOUR RIVETING PROFITABLY DONE?

Our Elastic Rotary Blow Riveting Machine does profitable work, because one machine will do the work of several hand riveters, and do it better.

Every head is perfectly formed, any shape, round, flat, oval, rectangular, etc.

Catalogue C tells more about it.

The F. B. SHUSTER COMPANY
New Haven, Conn.

Formerly John Adt & Son. Established 1866.
Also makers of Wire Straighteners and Cutter, Cotter Pin Machines, etc.

RIVETED STEEL TANKS FOR EVERY PURPOSE



OIL STORAGE - GASOLINE TANKS - AIR RECEIVERS
PNEUMATIC WATER SUPPLY TANKS - SMOKE STACKS
BOILER BREACHING - RIVETED STEEL PIPE - BINS & HOPPERS

NORTHERN CRANE WORKS, Limited
WALKERVILLE, ONT.

BUY IN CANADA!



NORTHERN CRANES

ELECTRIC AND HAND POWER
ALL SIZES, CAPACITIES AND TYPES.
ALSO ELECTRIC AND AIR HOISTS
Foundry Equipment—Cupolas, Ladles, Etc.



SILVER DRILLS

Increase the Output

Wherever these 20-inch drills have been introduced there has always followed a greater production of work. They are fast and sure. Four styles made. Either round or square base. Also made in gangs of 2, 3 and 4 spindles. Many other features—let us fully explain them.

Write to-day. Quick Deliveries.

Silver Manufacturing Co.
290 Broadway, Salem, Ohio

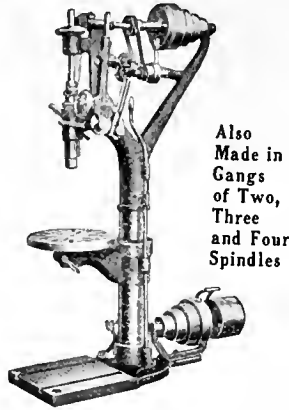

Also Made in Gangs of Two, Three and Four Spindles

NEW AIR-TIGHT BLAST GATE FOR LOW PRESSURE AIR

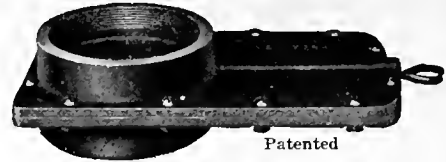

Patented

Save that air (money) you are now losing through leaky blast gates. Our NEW AIR-TIGHT BLAST GATE stops this loss.

Circular 123-B explains its many advantages. Copy on request.

W. S. ROCKWELL COMPANY
FURNACE ENGINEERS AND CONTRACTORS
50 Church Street Hudson Terminal Building New York

FERALUM
THE ULTIMATE IN DIAMOND SETTING
IT IS GUARANTEED

Finest Diamonds and Diamond Tools
THE GENERAL SUPPLY CO.
of Canada, Limited

OTTAWA TORONTO MONTREAL WINNIPEG
366 Sparks St., 125 Adelaide St. W., 408 McGill Bldg., 85 Water St.

Sole Canadian Agents for
GEO. A. JOYCE CO., Ltd.
NEW YORK LONDON

Our Ballas Diamonds Give Excellent Service

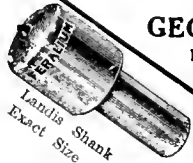

NORTON JACKS

FOR ALL KINDS OF HEAVY LIFTING
Send for complete catalogue showing 50 styles 10 to 100 tons capacity.

Made only by
A. O. NORTON, LIMITED
Coaticook, Prov. Quebec Canada

Every Tooth Cuts on Every *Quality* SAW
They cut straighter. They last longer.
NAPIER-SAW WORKS, Inc., Springfield, Mass., U. S. A.



GEARS AND GEAR CUTTING SPROCKETS AND CHAINS

In stock and to order any size from one-quarter inch to six-foot in diameter, any material. Estimates and gear advice cheerfully furnished.

Grant Gear Works, Inc. 151 Pearl St. Boston, Mass. U.S.A.
G. B. GRANT



Eye Protectors For All Work

Standard designs for chippers, machinists, grinders, furnacemen, etc. Can be worn over other glasses. Full particulars for the asking.

T. A. WILLSON & CO., INC.
23 Scott Street, Toronto, Ontario

9 Hatton Garden, London. Head Bldg., San Francisco. Mollers Bldg., Chicago.
Factory and Main Offices: **READING, Pa., U. S. A.**

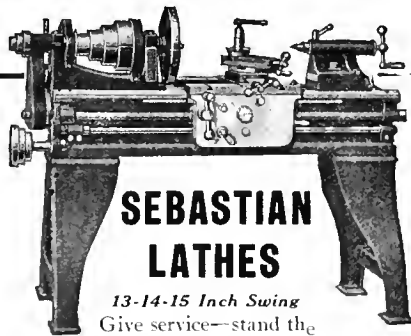

SEBASTIAN LATHES

13-14-15 Inch Swing
Give service—stand the

test of time. The first Sebastian Lathe built over 30 years ago. Send for catalog.

The Sebastian Lathe Co. 158 Culvert Street Cincinnati, O., U.S.A.

The Asa S. Cook Company HARTFORD, CONN.

Rivet Machines

WITH Absolutely Accurate Automatic Feed

In sizes to work blanks up to 6 inches long, 7/16 in. diameter stock. Capacity from 80 to 200 rivets per minute, according to size.

WRITE FOR COMPLETE PARTICULARS.



WE MANUFACTURE RIVETS of every description, 1/2 inch. dia. and smaller

PARMENTER & BULLOCH CO., LTD.
GANANOQUE, ONT.



End View

FRANCIS

Diamond Grinder Tools

for truing emery and carborundum wheels are giving great satisfaction everywhere because of the hard and high quality diamonds used. They will keep your abrasive wheels in good cutting condition.

Ask for descriptive circular and let us send you an assortment for selection.

FRANCIS & COMPANY

50 State St., Hartford, Conn., U. S. A.

Established in 1799

First National Bank Bldg.



End View



UNION Tool Chests

Mean Great Saving of Tools

Style D—3 Sizes.

Selected plain or quartered oak or leatherette covered.

Compact, roomy, a place for every tool. You know immediately if one is mislaid or borrowed. Drawers strong and perfectly fitted, some lined with felt. Keeps tools safe, clean and free from moisture.

WRITE FOR OUR CATALOG AND PRICES.

If dealer near you does not carry "UNIONS" in stock, get our special offer.

UNION TOOL CHEST WORKS 28 Railroad Street Rochester - N.Y.

YOURS IS READY TO MAIL YOUR WHAT?

YOUR CIRCULAR regarding Surface Grinders, New Yankee Drill Grinders, Universal Grinders.

Manufactured by

WILMARTH & MORMAN COMPANY

1200 Monroe Ave. N.W. Grand Rapids, Mich.

SEND FOR YOUR CIRCULAR NOW

PRESSES—ALL TYPES

Press Attachments, Automatic. Metal and Wire Forming Machines. Tumblers—Large Line. Burnishing Machines, Grinders. Special Machines.

Baird Machine Co., Bridgeport, Conn. U.S.A.



Taylor-Newbold Milling Cutters

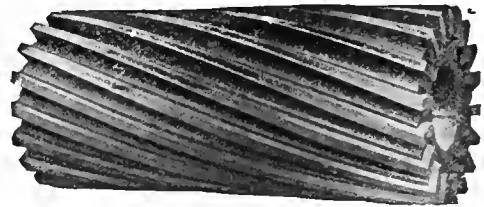

Continuous Helical Cutting Edges with constant clearance and rake angle throughout their length. Made in 4 in. diameter for general machine shop use.

Send for Bulletin R. P. and 30-day trial offer

THE TABOR MANUFACTURING COMPANY PHILADELPHIA, PA., U.S.A.

Cushman Chucks

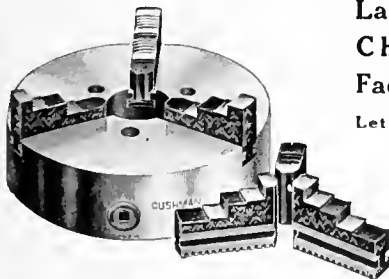

Lathe Chucks, Drill Chucks, Portable Face Plate Jaws.

Let us send you our catalog.

The Cushman Chuck Co.

Hartford, Conn., U.S.A.

22"

LENGTH KEYSEATS

Write for Catalog C

National Machine Tool Co.

2272 Spring Grove Ave., Cincinnati, Ohio, U. S. A.



THE DAVIS MILLING ATTACHMENT and Compound Table

For the Die Maker, Repair Shop, Pattern Maker or Garage; will perform more than 90% of the jobs that come up.

For any Drill Press 14" to 42" swing. Big Economy—Big convenience—Small Price. It relieves your large millers, comes in handy spotting castings, milling ends of bosses and many other odd jobs. Cuts all kinds of keyseats perfectly; mills deep grooves, slots and cans. We also make cylinder reamers for reboring Ford car, and a reliable air compressor—all at special factory prices. Write for circulars to-day.

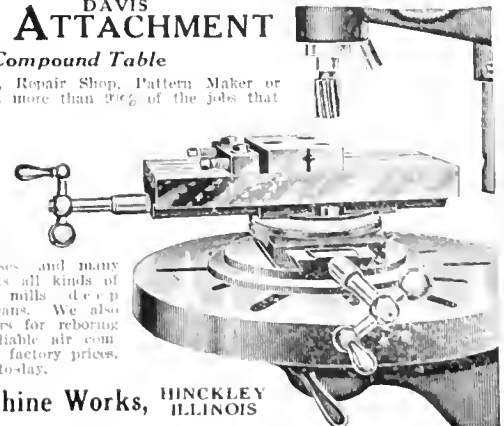

Hinckley Machine Works, HINCKLEY ILLINOIS

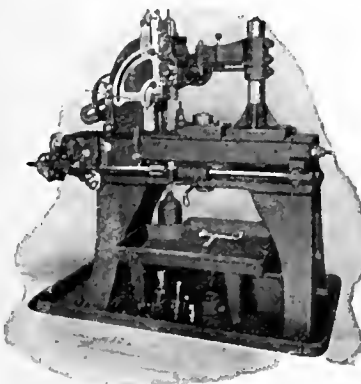

The Whiton **AUTOMATIC Gear Cutting Machine**

Do you want Catalog?

The D. E. Whiton Machine Co.

NEW LONDON, - CONN.

If any advertisement interests you, tear it out now and place with letters to be answered.

UNION DRAWN STEEL CO. LTD.

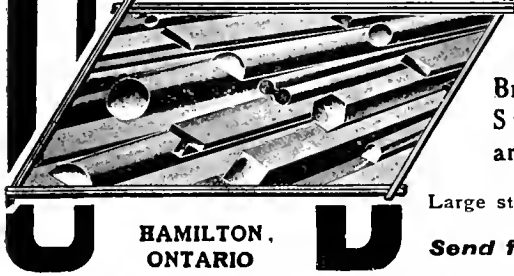

Manufacturers of
**Bright Finished
Steel Shafting
and Shapes.**

Large stock of all sizes.
Send for Price List

**HAMILTON,
ONTARIO**

SKINNER DRILL PRESS WISE

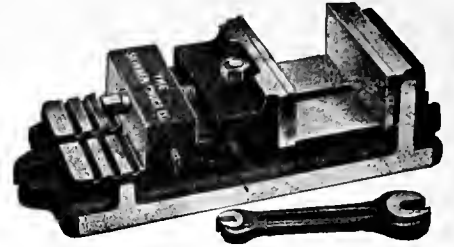

A substantial, durable tool which will pay for itself in short order in any machine shop. Four sizes to accommodate a wide range of work. Try one and you'll buy more.

Printed matter promptly mailed on request.

THE SKINNER CHUCK COMPANY

New York Office, London Office San Francisco Office
94 Reade Street 149 Queen Victoria St. Rialto Bldg.
Factory and Main Office, New Britain, Conn., U.S.A.

**VICES,
CHUCKS,
TWIST DRILLS,
and OTHER SMALL TOOLS,
and MACHINE TOOLS**

IN STOCK

Send us details of your requirements.

WELBORNE & CO.
Southferry Bldg.
NEW YORK
U.S.A.

WILKINSON & KOMPASS

TORONTO HAMILTON WINNIPEG

IRON AND STEEL

HEAVY HARDWARE
MILL SUPPLIES
AUTOMOBILE ACCESSORIES

WE SHIP PROMPTLY

Trade Mark Reg. U. S. Pat. Office

A universal grinder. A grinder with all attachments. A grinder that will handle all kinds of tool-sharpening as well as cylindrical, internal and surface grinding. An all-around machine for your tool-room.

Catalog No. 6.

Greenfield Machine Co.

Greenfield, Mass., U.S.A.

Zenith Coal & Steel Products Limited

COAL COKE HACK SAW BLADES
CARBON STEEL MACHINERY STEEL
HIGH SPEED STEEL

Royal Bank Bldg., Toronto; McGill Bldg., Montreal, Que.

Oxy-Acetylene Welding and Cutting Apparatus

Carter Welding Co., General Toronto
For Davis-Bournonville Oxy-Acetylene Apparatus
General Office and Factory, Jersey City, N.J.
Canadian Factory, Niagara Falls, Ont.
Sales Offices: New York, Boston, Philadelphia, Pittsburgh, Cleveland, Cincinnati, Chicago, Detroit, St. Louis, San Francisco, Seattle.

Beaudry Hammers

FOR GENERAL FORGING

Save Fuel, Time and Labor. Cut Forging Costs in two.

BELT OR MOTOR DRIVEN

BEAUDRY & COMPANY, Inc.

141 Milk Street, Boston, Mass.
Alfred Herbert, Ltd., Coventry, England, London, Paris, Calcutta, Yokohama.

SHAFTING

Cold Drawn, Turned and Polished Steel, Rounds, Squares, Hexagons and Flats, Steel Piston Rods, Pump Rods.

Special facilities for Keyseating up to 6 in. diameter.

THE Canadian Drawn Steel Co.

HAMILTON Limited CANADA

Mention this paper when writing advertisers. It will identify the proposition about which you require information.

Canadian Machinery BUYERS DIRECTORY

If what you want is not listed here write us, and we will tell you where to get it. Let us suggest that you consult also the advertisers' index facing the inside back cover, after having secured advertisers' names from this directory. The information you desire may be found in the advertising pages. This department is maintained for the benefit and convenience of our readers. The insertion of our advertisers' names under proper headings is gladly undertaken, but does not become part of an advertising contract.

ABRASIVE MATERIALS

Aikenhead Hardware Co., Toronto, Ont.
 Baxter Co., Ltd., J. R., Montreal, Que.
 Canadian Fairbanks-Morse Co., Montreal.
 Can. Hart Wheels, Ltd., Hamilton, Ont.
 Can. B. K. Morton, Montreal, Que.
 Carborundum Co., Niagara Falls, N.Y.
 Dominion Abrasive Wheel Co., New Toronto, Ontario.
 Foss & Hill Machy, Co., Montreal.
 Ford-Smith Mach. Co., Hamilton, Ont.
 Gardner Machine Co., Beloit, Wis.
 Norton Co., Worcester, Mass.
 H. W. Petrie, Toronto.
 H. W. Petrie, of Montreal, Ltd., Montreal.

ACETYLENE

Carter Welding Co., Toronto, Ont.
 Commercial Acetylene Welding Co., Inc., Toronto,
 L'Air Liquide Society, Montreal, Toronto.
 Prest-O-Lite Co., Inc., Toronto, Ont.

ACETYLENE GENERATORS

Commercial Acetylene Welding Co., Inc., Toronto,
 L'Air Liquide Society, Montreal, Toronto.
 Prest-O-Lite Co., Inc., Toronto, Ont.

ACCUMULATORS, HYDRAULIC

Canadian Fairbanks-Morse Co., Montreal.
 Charles F. Elmes Eng. Works, Chicago.
 Garlock-Walker Machinery Co., Toronto, Ont.
 Niles-Bement-Pond Co., New York.
 Smart-Turner Mach. Co., Hamilton, Ont.
 William B. Perrin, Ltd., Toronto.

AIR RECEIVERS

Can. Ingersoll-Rand Co., Sherbrooke, Que.
 The Jencks Mach. Co., Ltd., Sherbrooke, Que.
 MacKinnon, Holmes Co., Sherbrooke, Que.

AIR WASHERS

Can. Blower & Forge Co., Kitchener, Ont.
 Sheldons, Ltd., Galt, Ont.

ALUMINUM

Canada Metal Co., Toronto.
 Tallman Brass & Metal Co., Hamilton.

ALLOY, STEEL

Can. B. K. Morton, Toronto, Montreal.
 Comstedt, Josef F. A., 120 Broadway, New York.
 H. A. Drury Co., Ltd., Montreal.
 Firth & Sons, Thos., Montreal, Que.
 Hawkrige Bros. Co., Boston, Mass.
 Michigan Steel Exchange, Inc., Detroit, Mich.
 Osborn (Canada), Ltd., Sam'l, Montreal, Que.
 Standard Alloys Company, Pittsburgh, Ont.
 Vanadium Alloys Steel Co., Pittsburg, Pa.
 Vulcan Crucible Steel Co., Aliquippa, Pa.

ARBORS

Canadian Fairbanks-Morse Co., Montreal.
 Cleveland Twist Drill Co., Cleveland.
 Garlock-Walker Machinery Co., Toronto, Ont.
 Morse Twist Drill & Mach. Co., New Bedford, Mass.
 H. W. Petrie, Toronto.
 H. W. Petrie, Ltd., Montreal.
 Pratt & Whitney Co., Dundas, Ont.

AUTOGENOUS WELDING AND CUTTING PLANTS

Carter Welding Co., Toronto, Ont.
 L'Air Liquide Society, Montreal, Toronto.
 Prest-O-Lite Co., Inc., Toronto, Ont.

AUTOMATIC MACHINERY

Baird Machine Co., Bridgeport, Conn.
 Cook, Asa S., Hartford, Conn.
 Dominion Machinery Co., Toronto.
 Garlock-Walker Machinery Co., Toronto, Ont.
 Gardner, Robt., & Son, Montreal.
 McClean & Son, F. W., Niagara Falls, Ont.
 Riverside Machinery Depot, Detroit, Mich.
 H. W. Petrie, Toronto.
 H. W. Petrie, Ltd., Montreal.
 Pratt & Whitney Co., Dundas, Ont.
 Rodefson Machine & Tool Co., Toronto, Ont.
 A. R. Williams Machy. Co., Toronto.

AUTOMATIC WOOD SCREW MACHINES

Cook, Asa S., Hartford, Conn.

BABBITT METAL

Aikenhead Hardware Co., Toronto, Ont.
 Baxter Co., Ltd., J. R., Montreal, Que.
 Canadian Fairbanks-Morse Co., Montreal.
 Canada Metal Co., Ltd., Toronto.
 Can. B. K. Morton, Toronto, Montreal.
 Dominion Metal Co., Sherbrooke, Que.
 Foss & Hill Machy, Co., Montreal.
 Hart Metal Co., Toronto.
 Hungerford Brass & Copper Co., U. T., New York.
 Johnson, Geo. A., Hamilton, Ont.
 Magnolia Metal Co., Montreal.
 H. W. Petrie, Toronto.
 Tallman Brass & Metal Co., Hamilton.

BALL BEARINGS

Canadian Fairbanks-Morse Co., Montreal.
 Can. S. K. F. Co., Toronto, Ont.
 Chapman Double Ball Bearing Company, Toronto.
 Lyman Tube & Supply Co., Montreal, Que.
 R. E. T. Pringle, Ltd., Toronto, Ont.

BARRELS, STEEL SHOP

Baird Machine Co., Bridgeport, Conn.
 Cleveland Wire Spring Co., Cleveland.

BASE FACING MACHINES

Rollins Engine Works, Nashua, N.H.
 Victoria Foundry Co., Ottawa, Ont.

BABBITT RETAINER

A. S. K. Chemical Co., Elora, Ont.

BAR, BORING

Charles F. Elmes Eng. Works, Chicago, Ill.
 Monarch Brass Mfg. Co., Toronto, Ont.
 Niles-Bement-Pond Co., New York.
 Webber Bros. Mach. Co., Toronto, Ont.

BELLS, MARINE

Ontario Specialties, Ltd., Ottawa, Can.

BELT LACERS

Clipper Belt Lacer Co., Grand Rapids, Mich.

BELT DRESSING AND CEMENT

Baxter Co., Ltd., J. R., Montreal, Que.

BELT LACING LEATHER

Aikenhead Hardware Co., Toronto, Ont.
 Foss & Hill Machy, Co., Montreal.
 Graton & Knight Mfg. Co., Worcester, Mass.

BELTING, BALATA

Baxter Co., Ltd., J. R., Montreal, Que.
 Can. B. K. Morton, Toronto, Montreal.

BELTING, CHAIN

Canadian Fairbanks-Morse Co., Montreal.
 Jones & Glasco, Montreal, Que.
 Morse Chain Co., Ithaca, N.Y.
 H. W. Petrie, Toronto.
 H. W. Petrie, Ltd., Montreal.
 Whitney Mfg. Co., Hartford, Conn.

BELTING, CONVEYOR

Dunlop Tire & Rubber Goods Co., Ltd., Toronto, Ont.
 Goodyear Tire & Rubber Co., Toronto, Ont.

BELTING, LEATHER

Canadian Fairbanks-Morse Co., Montreal.
 Can. B. K. Morton, Montreal, Que.
 Dominion Machinery Co., Toronto.
 Graton & Knight Mfg. Co., Worcester, Mass.
 Goodyear Tire & Rubber Co., Toronto, Ont.
 McArthur Belting Co., Brockville, Ont.
 McLaren, Ltd., D. K., Montreal, Que.
 McLaren, J. C., Belting Co., Montreal, Que.
 Montreal Machy. & Supplies, Ltd., Montreal, Que.
 Morse Chain Co., Ithaca, N.Y.
 H. W. Petrie, Ltd., Montreal.
 Sadler & Howarth, Montreal, Que.

BELTING, STITCHED COTTON DUCK

Baxter Co., Ltd., J. R., Montreal, Que.
 Bennett, W. P., 51 Montford St., Montreal, Que.
 Dominion Belting Co., Hamilton, Ont.
 McArthur Belting Co., Brockville, Ont.
 H. W. Petrie, Ltd., Montreal.
 H. W. Petrie, Toronto.

BENCH LEGS, STEEL

New Britain Mach. Co., New Britain, Conn.

BENCH DRAWERS, FRICTIONLESS

New Britain Mach. Co., New Britain, Conn.

BENDING MACHINERY

John Bertram & Sons Co., Dundas.
 Bertrams, Limited, Edinburgh, Scotland.
 Bliss, E. W., Co., Brooklyn, N.Y.
 Brown Boggs Co., Ltd., Hamilton, Can.
 Can. Blower & Forge Co., Kitchener, Canada.
 Dominion Machinery Co., Toronto.
 Garlock-Walker Machinery Co., Toronto, Ont.
 Charles F. Elmes Eng. Works, Chicago.
 Jardine, A. R., & Co., Hopseler Ont.
 National Machinery Co., Tiffin, Ohio.
 Niles-Bement-Pond Co., New York.
 H. W. Petrie, Ltd., Montreal.
 H. W. Petrie, Toronto.
 Steel Bending Brake Works, Chatham, Ont.
 Toledo Machine & Tool Co., Toledo O.

BULLET MARKERS

Matthews, Jas. H., & Co., Pittsburgh, Pa.

BUNS, STEEL

The Jencks Mach. Co., Ltd., Sherbrooke, Que.
 MacKinnon, Holmes Co., Sherbrooke, Que.

BLASTING MACHINES, SHOT AND STEEL GRIT

Gray Mfg. & Mach. Co., Toronto, Ont.

BLOWERS

Can. Blower & Forge Co., Kitchener, Ont.
 Sheldons, Ltd., Galt, Ont.
 Garlock-Walker Machinery Co., Toronto, Ont.
 H. W. Petrie, Ltd., Montreal.
 R. E. T. Pringle, Ltd., Toronto, Ont.
 Riverside Machinery Depot, Detroit, Mich.
 Sturtevant Co., E. F., Galt, Ont.

BLOW PIPES AND REGULATORS

Carter Welding Co., Toronto, Ont.
 L'Air Liquide Society, Montreal, Toronto.
 Prest-O-Lite Co., Inc., Toronto, Ont.

BLUE PRINTS

Wickes Bros., Saginaw, Mich.

BLUE PRINTING MACHINERY

Commercial Camera Co., Providence, R.I.
 Mulliner-Enlund Tool Co., Syracuse, N.Y.

Wickes Bros., Saginaw, Mich.

BOARZZ

Francis & Co., Hartford, Conn.
 Geo. A. Joyce Co., Ltd., New York, N.Y.

Wheel Trueing Tool Co., Windsor, Ont.

BOILERS

The Jencks Mach. Co., Ltd., Sherbrooke, Que.
 MacKinnon, Holmes Co., Sherbrooke.
 H. W. Petrie, Ltd., Montreal.
 H. W. Petrie, Toronto.
 Riverside Machinery Depot, Detroit, Mich.
 Wickes Bros., Saginaw, Mich.

BOLT CUTTERS AND NUT TAPERS

Aikenhead Hardware Co., Toronto, Ont.
 Canada Machinery Corp., Galt, Ont.

Wells Brothers Co. of Canada, Galt, Ont.

BOLTS

Aikenhead Hardware Co., Toronto, Ont.
 Cumming & Son, J. W., New Glasgow, Canada.
 Galt Machine Screw Co., Galt, Ont.
 London Bolt & Hinge Works, London, Ont.
 Steel Co. of Canada, Ltd., Hamilton, Ont.

BOLT AND NUT MACHINERY

John Bertram & Sons Co., Dundas.
 Canada Machinery Corp., Galt, Ont.
 Dominion Machy. Co., Toronto, Ont.
 Garlock-Walker Machinery Co., Toronto, Ont.
 Gardner, Robt., & Son, Montreal.
 Landis Machine Co., Waynesboro, Pa.
 National Machinery Co., Tiffin, O.
 H. W. Petrie, Ltd., Montreal.
 H. W. Petrie, Toronto.
 Riverside Machinery Depot, Detroit, Mich.
 A. R. Williams Machinery Co., Toronto.

BOLTS AND NUTS, BRASS, COPPER AND BRONZE

Hungerford Brass & Copper Co., New York, N.Y.

BOLT THREADING MACHINERY

Cook, Asa S., Co., Hartford, Conn.
 Victor Tool Co., Waynesboro, Pa.

BOOKS, TECHNICAL

Maclean Publishing Co., Toronto.
 Whittaker & Co., London, (Eng.), E.C.

BORING MACHINES, PNEUMATIC CYLINDER

Cleveland Pneumatic Tool Co. of Canada, Toronto.
 Canadian Fairbanks-Morse Co., Ltd., Montreal.
 Can. Ingersoll-Rand Co., Sherbrooke, Que.
 Garlock-Walker Machinery Co., Toronto, Ont.
 H. W. Petrie, Ltd., Montreal.
 H. W. Petrie, Toronto.
 Stow Mfg. Co., Binghamton, N.Y.

BORING MACHINES, UPRIGHT AND HORIZONTAL

John Bertram & Sons Co., Dundas.
 Canada Machinery Corp., Galt, Ont.
 Dominion Machinery Co., Toronto.
 Garlock-Walker Machinery Co., Toronto, Ont.
 Niles-Bement-Pond Co., New York.
 H. W. Petrie, Ltd., Montreal.
 Rodefson Machine & Tool Co., Toronto, Ont.
 Riverside Machinery Depot, Detroit, Mich.
 Stow Mfg. Co., Binghamton, N.Y.

BORING MACHINES, STOVE AND COAL

Cumming & Son, J. W., New Glasgow, Canada.

BORING AND TURNING MILLS

John Bertram & Sons Co., Dundas.
 Canada Machinery Corp., Galt, Ont.
 Foss & Hill Machy, Co., Montreal.
 Niles-Bement-Pond Co., New York.
 H. W. Petrie, Ltd., Montreal.
 H. W. Petrie, Toronto.
 R. E. T. Pringle, Ltd., Toronto, Ont.

BOXES, STEEL SHOP AND TOTE

Cleveland Wire Spring Co., Cleveland.
 New Britain Mach. Co., New Britain, Conn.

BRACKS

Brown, Boggs & Co., Hamilton, Can.
 Steel Bending Brake Wks., Ltd., Chatham, Ont.

BRASS AND COPPER BARS, RODS AND SHEETS

Brown's Copper & Brass Rolling Mills, New Toronto.

BRASS WORKING MACHINERY

Dominion Machy. Co., Toronto, Ont.
 Firth Machine Co., Elkhart, Ind.
 Garlock-Walker Machinery Co., Toronto, Ont.
 Warner & Swasey Co., Cleveland.
 Niles-Bement-Pond Co., New York.
 H. W. Petrie, Ltd., Montreal.
 H. W. Petrie, Toronto.
 Prest-O-Lite Co., Inc., Toronto, Ont.
 Riverside Machinery Depot, Detroit, Mich.
 A. R. Williams Machy. Co., Toronto.

BRIDGES, RAILWAY AND HIGHWAY

Corbet Eddy & Mach. Co., Ltd., Owen Sound, Ont.
 The Jencks Mach. Co., Ltd., Sherbrooke, Que.
 MacKinnon, Holmes Co., Sherbrooke, Que.

BRONZE RODS AND SHEETS

Brown's Copper & Brass Rolling Mills, New Toronto.

Hungerford Brass & Copper Co., U. T., New York.

BIBBLERS

Puro Sanitary Drinking Fountain Co., Haydenville, Mass.

BUCKETS, CLAM SHELL, CRAB, DUMP

Northern Crane Works, Ltd., Walkerville, Ont.

Whiting Foundry Equipment Co., Harvey, Ill.

BUFFING AND POLISHING MACH.

Ford-Smith Mach. Co., Hamilton, Ont.

Foss & Hill Machy. Co., Montreal.

Garlock-Walker Machinery Co., Toronto, Ont.

New Britain Machine Co., New Britain, Conn.

H. W. Petrie, Ltd., Montreal.

R. E. T. Pringle, Ltd., Toronto, Ont.

BUCKETS, ELEVATING AND HOISTING

Banfield, Edwin J., Toronto.

BULLDOZERS

John Bertram & Sons Co., Dundas.

E. W. Bliss Co., Brooklyn, N.Y.

Canada Machinery Corp., Galt, Ont.

BURNERS, OIL AND NATURAL GAS

Bellevue Industrial Furnace Co., Detroit, Mich.

Gray Mfg. & Mach. Co., Toronto, Ont.

Northern Crane Works, Ltd., Walkerville, Ont.

Oven Equipment & Mfg. Co., New Haven, Conn.

BURRING REAMERS

Wells Bros. Co. of Canada, Galt, Ont.

BURRS, IRON AND COPPER

Hungerford Brass & Copper Co., New York, N.Y.

Parmenter & Bulloch Co., Gananoque.

BUTTERISERS

Wells Bros. Co. of Canada, Galt, Ont.

CANNERS' MACHINERY

Bliss, E. W., Co., Brooklyn, N.Y.

Brown, Boggs & Co., Hamilton, Can.

Prest-O-Lite Co., Inc., Toronto, Ont.

CARS, INDUSTRIAL

Corbet Fdry. & Mach. Co., Ltd., Owen Sound, Ont.

Can. Blower & Forge Co., Kitchener, Can.

Canadian Fairbanks-Morse Co., Ltd., Montreal.

Cumming & Son, J. W., New Glasgow, Canada.

The Jencks Mach. Co., Ltd., Sherbrooke, Que.

Marsh & Henthorn, Belleville, Ont.

Mercury Mfg. Co., Chicago, Ill.

Sheldons, Limited, Galt, Ont.

Whiting Foundry Equipment Co., Harvey, Ill.

CAR MOVERS

Dillon Mfg. Co., Oshawa, Ont.

CARTRIDGE MAKING MACHINERY

Blackhall, Fred. S., Woolworth Tower, New York.

Prest-O-Lite Co., Inc., Toronto, Ont.

CASTINGS, ALUMINUM, BRASS,**BRONZE, COPPER**

Corbet Fdry. & Mach. Co., Ltd., Owen Sound, Ont.

Cumming & Son, J. W., New Glasgow, Canada.

Alexander Fleck, Ltd., Ottawa.

Hungerford Brass & Copper Co., New York, N.Y.

The Jencks Mach. Co., Ltd., Sherbrooke, Que.

Ontario Specialties, Ltd., Ottawa, Can.

Tallman Brass & Metal Co., Hamilton.

CASTINGS, GRAY IRON

Bernard Industrial Co., The A., Fortierville, Que.

Brown, Boggs Co., Ltd., Hamilton, Canada.

Can. Steel Foundries, Ltd., Montreal, Que.

Alexander Fleck, Ltd., Ottawa.

Gardner, Robt., & Son, Montreal.

Hull Iron & Steel Foundries, Ltd., Hull, Quebec.

The Jencks Mach. Co., Ltd., Sherbrooke, Que.

Wm. Kennedy & Sons, Ltd., Owen Sound.

Plessisville Foundry Co., Plessisville, Que.

Sheldons, Limited, Galt, Ont.

CASTINGS, STEEL CHROME**AND MANGANESE STEEL**

Can. Steel Foundries, Ltd., Montreal, Que.

Dominion Steel Foundry Co., Ltd., Hamilton, Ont.

Hull Iron & Steel Foundries, Ltd., Hull, Quebec.

Wm. Kennedy & Sons, Ltd., Owen Sound.

Mackintosh, Hemphill & Co., Pittsburgh, Pa.

Ontario Specialties, Ltd., Ottawa, Can.

CASTINGS, MALLEABLE

Can. Steel Foundries, Ltd., Montreal, Que.

Cumming & Son, J. W., New Glasgow, Canada.

CASTINGS, NICKEL STEEL

Hull Iron & Steel Foundries, Ltd., Hull, Quebec.

Mackintosh, Hemphill & Co., Pittsburgh, Pa.

CEMENT MACHINERY

Canadian Fairbanks-Morse Co., Ltd., Montreal.

Gardner, Robt., & Son, Montreal.

H. W. Petrie, Toronto.

CENTERING MACHINES

Victoria Foundry Co., Ottawa, Ont.

CENTRE REAMERS

Wells Brothers Co., Greenfield, Mass.

John Bertram & Sons Co., Dundas.

Gardner, Robt., & Son, Montreal.

Hurlbut, Rogers Machy. Co., South Sudbury, Mass.

Niles-Bement-Pond Co., New York.

Pratt & Whitney Co., Dundas, Ont.

CHAIN BLOCKS

Aikenhead Hardware Co., Toronto, Ont.

Canadian Fairbanks-Morse Co., Ltd., Montreal.

Ford Chain Block & Mfg. Co., Philadelphia, Pa.

Foss & Hill Machy. Co., Montreal.

Garlock-Walker Machinery Co., Toronto, Ont.

Lyman Tube & Supply Co., Montreal, Que.

H. W. Petrie, Ltd., Montreal.

H. W. Petrie, Toronto.

CHEMISTS

Can. Inspection & Testing Lab., Montreal, Que.

The Jencks Mach. Co., Ltd., Sherbrooke, Que.

Toronto Testing Laboratory, Ltd., Toronto.

CHESTS, TOOL

Union Tool Chest Works, Rochester, N.Y.

CHUCKS, AERO, AUTOMATIC

Garrin Machine Co., New York.

Hannifin Mfg. Co., Chicago, Ill.

Hyve Engineering Works, Montreal.

CHUCKS, AIR

Manufacturers Equip. Co., Chicago, Ill.

CHUCKS, COLLET

Hannifin Mfg. Co., Chicago, Ill.

CHUCKS, DRILL, LATHE AND UNIVERSAL

Aikenhead Hardware Co., Toronto, Ont.

John Bertram & Sons Co., Dundas, Ont.

Can. Blower & Forge Co., Kitchener, Canada.

Canadian Fairbanks-Morse Co., Ltd., Montreal.

Cushman Chuck Co., Hartford, Conn.

Detroit Pneumatic Chuck Co., Detroit, Mich.

Foss & Hill Machy. Co., Montreal.

Gardner, Robt., & Son, Montreal.

Garlock-Walker Machinery Co., Toronto, Ont.

Hannifin Mfg. Co., Chicago, Ill.

Latting Bros., Chicago, Ill.

Hogson & Pettis Mfg. Co., New Haven, Conn.

Jacobs Mfg. Co., Hartford, Conn.

Jersey City Machine Co., Jersey City, N.J.

Ker & Goodwin, Brantford.

Manufacturers Equipment Co., Chicago, Ill.

Millers Falls Co., Millers Falls, Mass.

Modern Tool Co., Erie, Pa.

Morse Twist Drill & Machine Co., New Bedford.

Richmond Mfg. Co., Toronto, Ont.

H. W. Petrie, Ltd., Montreal.

H. W. Petrie, Toronto.

Skinner Chuck Co., New Britain, Conn.

Thomas Elevator Co., Chicago, Ill.

Welborne & Co., New York, N.Y.

D. E. Whiton Machine Co., New London, Conn.

CHUCKS, DRILL, AUTOMATIC AND KEYLESS

Aikenhead Hardware Co., Toronto, Ont.

Corbet Fdry. & Mach. Co., Ltd., Owen Sound, Ont.

Can. Blower & Forge Co., Kitchener, Canada.

Whitney Mfg. Co., Hartford, Conn.

Richmond Mfg. Co., Toronto, Ont.

CHUCKS, FRICTION AND TAP

Victor Tool Co., Waynesboro, Pa.

Wells Bros. Co. of Canada, Galt, Ont.

CHUCKS, GEARED SCROLL

Hogson & Pettis Mfg. Co., New Haven, Conn.

Richmond Mfg. Co., Toronto, Ont.

CHUCKS, KING WHEEL

Ford-Smith Mach. Co., Hamilton, Ont.

Gardner Machine Co., Beloit, Wis.

CHUCKS, SPLIT

Rivet Lathe & Grinder Co., Brighton, Mass.

CHUCKING MACHINES

Garrin Machine Co., New York.

New Britain Machine Co., New Britain, Conn.

Niles-Bement-Pond Co., New York.

Roelofson Machine & Tool Co., Toronto, Ont.

Warner & Swasey Co., Cleveland, O.

CLUTCHES, FRICTION AND PULLEY

Bernard Industrial Co., A., Fortierville, Que.

Johnson Machine Co., Carlyle, Manchester, Conn.

Positive Clutch & Pulley Works, Ltd., Toronto.

COAL HANDLING MACHINERY

Mackinnon, Holmes & Co., Sherbrooke, Que.

Northern Crane Works, Ltd., Walkerville, Ont.

Whiting Foundry Equipment Co., Harvey, Ill.

COKE AND COAL

Hanna & Co., M. A., Cleveland, O.

Zenith Steel & Coal Products, Montreal, Que.

COLLARS

Can. Bond Hanger & Cplg. Co., Alexandria, Ont.

COLLECTORS, PNEUMATIC

Can. Blower & Forge Co., Kitchener, Ont.

Sheldons, Limited, Galt, Ont.

Stratvean Co., B. F., Galt, Ont.

COLLETS

Hyve Engineering Works, Montreal.

Manufacturers' Equipment Co., Chicago, Ill.

Rivet Lathe & Grinder Co., Boston, Mass.

Stone Tool & Supply Co., J. R., Detroit, Mich.

COMPRESSORS, AIR

Can. Ingersoll-Rand Co., Sherbrooke, Que.

Cleveland Pneumatic Tool Co. of Canada, Toronto.

Curtis Pneumatic Tool Co., St. Louis, Mo.

Garlock-Walker Machinery Co., Toronto, Ont.

The Jencks Mach. Co., Ltd., Sherbrooke, Que.

H. W. Petrie, Ltd., Montreal.

H. W. Petrie, Toronto.

Reversible Machinery Depot, Detroit, Mich.

Smart-Turner Machine Co., Hamilton, Ont.

Taylor Instrument Cos., Rochester, N.Y.

Wickes Brothers, Saginaw, Mich.

CONDENSER TUBES AND FERRULES, PRESS

Hungerford Brass & Copper Co., New York, N.Y.

CONTROLLERS AND STARTERS, ELECTRIC MOTORS

Dominion Machy. Co., Toronto, Ont.

H. W. Petrie, Toronto.

R. E. T. Pringle, Ltd., Toronto, Ont.

A. R. Williams Machy. Co., Toronto.

CONTROLLING INSTRUMENTS

Taylor Instrument Cos., Rochester, N.Y.

CONVERTERS, STEEL SLIDE-BLOW

Whiting Foundry Equipment Co., Harvey, Ill.

COPING MACHINES

Can. Blower & Forge Co., Kitchener, Ont.

John Bertram & Sons Co., Dundas.

Niles-Bement-Pond Co., New York.

COUNTERBORES AND COUNTERSINKS

Aikenhead Hardware Co., Toronto, Ont.

Cleveland Twist Drill Co., Cleveland.

Morse Twist Drill & Machine Co., New Bedford.

Pratt & Whitney Co., Dundas, Ont.

COUNTERSHAFTS

Baird Machine Co., Bridgeport, Conn.

Corbet Fdry. & Mach. Co., Ltd., Owen Sound, Ont.

Foster Machine Co., Elkhart, Ind.

Webber Bros. Mach. Co., Toronto, Ont.

COUPLINGS, FRICTION

Bernard Industrial Co., The A., Fortierville, Que.

COUPLINGS, PLAIN AND FLEXIBLE

Can. Bond Hanger & Cplg. Co., Alexandria, Ont.

Corbet Fdry. & Mach. Co., Ltd., Owen Sound, Ont.

Cleveland Pneumatic Tool Co. of Canada, Toronto.

Gardner, Robt., & Son, Montreal.

Independent Pneumatic Tool Co., Chicago, Ill.

CRANES, LOCOMOTIVE

Northern Crane Works, Walkerville.

CRANES, GANTRY

Northern Crane Works, Walkerville.

Smart-Turner Machine Co., Hamilton, Ont.

Whiting Foundry Equipment Co., Harvey, Ill.

CRANES, GOLIATH AND PNEUMATIC

Northern Crane Works, Walkerville.

Whiting Foundry Equipment Co., Harvey, Ill.

CRANES, PORTABLE

Aikenhead Hardware Co., Toronto, Ont.

Northern Crane Works, Walkerville.

Whiting Foundry Equipment Co., Harvey, Ill.

CRANES, TRAVELLING, ELECTRIC AND HAND POWER

Curtis Pneumatic Machy. Co., St. Louis, Mo.

Dominion Bridge Co., Montreal.

Heppner, John T., Ltd., Toronto, Ont.

Niles-Bement-Pond Co., New York.

Northern Crane Works, Walkerville.

CRIMPING, LEATHER

Graton & Knight Mfg. Co., Worcester, Mass.

CUPOLAS

Can. Blower & Forge Co., Kitchener, Ont.

Northern Crane Works, Walkerville.

H. W. Petrie, Toronto.</

“ACCURACY—The First Requirement of Every Brown & Sharpe Product”

We Could Build Them Quicker But *Not* Better

We could build our milling machines faster at the sacrifice of Brown & Sharpe standards. They would look very much the same even to the smaller details—but

BROWN & SHARPE MACHINES MUST BE ACCURATE

and to get permanent accuracy, careful workmanship must enter into every important step in their manufacture. The great care used, however, does not mean that unnecessary time is consumed in building the parts or assembling them—just long enough to insure maintenance of Brown & Sharpe standards for accuracy that have been world-known for years.

You will find satisfaction and profit in an installation of

Brown & Sharpe Heavy Service Milling Machines

Brown & Sharpe Mfg. Co., Providence, R.I., U.S.A.

Canadian Representative:—CANADIAN FAIRBANKS-MORSE CO., LIMITED

Toronto

Montreal

Vancouver

Winnipeg

Calgary

St. John

Saskatoon

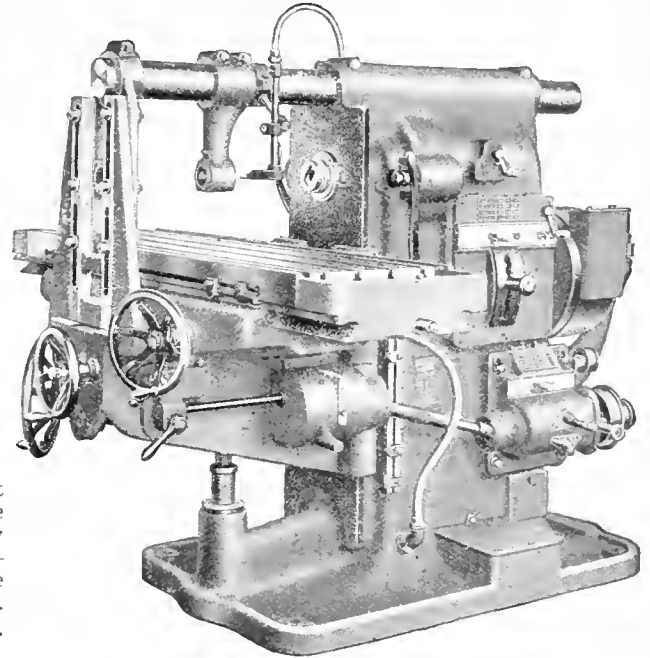

Cuts Costs
Increases
Production

— it is a *Rockford Machine*

This powerful machine is made to drive high-speed drills up to 3" diameter, for drilling and boring tools up to 8" in diameter for boring out cored holes in cast iron.

It has a lateral and vertical adjustment of the head that permits the spindle to operate anywhere on a surface 18" high by 36" wide.

Sufficiently accurate for the finest jig work.

Investigate now. Write us for full particulars and specifications.

Used for
the finest
of Jig
Work.

Rockford Drilling Machine Co.

Rockford, Ill., U.S.A.

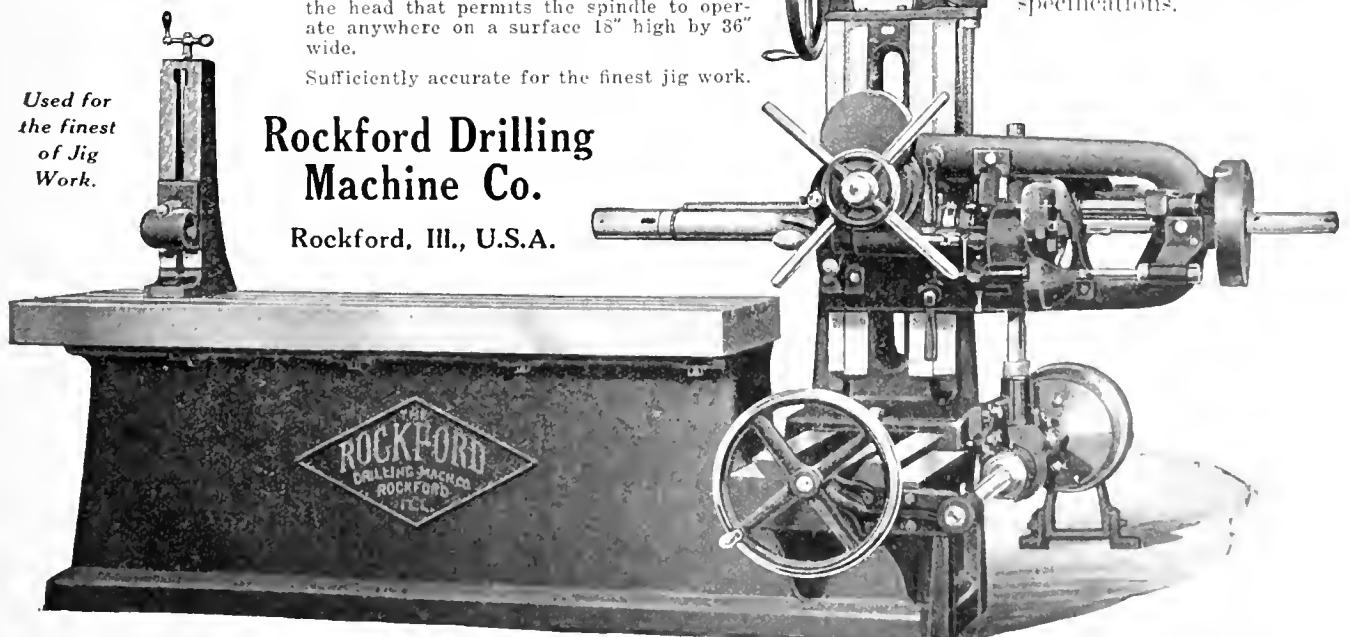

If any advertisement interests you, tear it out now and place with letters to be answered.

DIES FOR BIT BRACE USE

Wells Brothers of Canada, Galt, Ont.

DIES, NOSING

Marsh & Henthorn, Ltd., Belleville, Ont.

DIES, PIPE-THREADING

Ideal Tool & Mfg. Co., Beaver Falls, Pa.

DIE SINKERS

Cook, Asa S., Co., Hartford, Conn.

Garvin Machine Co., New York

H. W. Petrie, Ltd., Montreal

DIES FOR MACHINES

Aikenhead Hardware Co., Toronto, Ont.

Wells Brothers Co. of Canada, Galt, Ont.

DIE SINKING PRESSES, HYDRAULIC

Charles F. Elmes Eng. Works, Chicago.

DIES, SELF-OPENING

Eastern Mach. Sewing Corp., New Haven, Conn.

Geometric Tool Co., New Haven.

Ideal Tool & Mfg. Co., Beaver Falls, Pa.

Landis Machine Co., Waynesboro, Pa.

Modern Tool Co., Erie, Pa.

Murphy Machine & Tool Co., Detroit, Mich.

Wells Brothers Co. of Canada, Galt, Ont.

DIES FOR SCREW PLATES

Wells Brothers Co. of Canada, Galt, Ont.

DIES, SHEET METAL WORKING

E. W. Bliss Co., Brooklyn, N.Y.

Brown, Boggs & Co., Hamilton, Canada.

Worth Engineering Co., Toronto, Ont.

DISCS, LEATHER

Graton & Knight Mfg. Co., Worcester, Mass.

DIES, SCREWS AND THREAD

Landis Machine Co., Waynesboro, Pa.

Modern Tool Co., Erie, Pa.

Murphy Machine & Tool Co., Detroit, Mich.

National-Acme Co., Cleveland, Ohio.

Wells Brothers Co. of Canada, Galt, Ont.

DRAFT, MECHANICAL

W. H. Banfield & Sons, Toronto.

Butterfield & Co., Rock Island, Que.

Can. Blower & Forge Co., Kitchener, Ont.

A. B. Jardine & Co., Hespeler, Ont.

Pratt & Whitney Co., Dundas, Ont.

Sheldons, Ltd., Galt, Ont.

DISCS, LEATHER

Graton & Knight Mfg. Co., Montreal.

DRESSERS, GRINDING AND EMERY WHEEL

Can. Desmond-Stephan Mfg. Co., Hamilton, Ont.

Ford-Smith Mach. Co., Hamilton, Ont.

DRILL PRESSES

Adams, O. R., 159 St. Paul St. Rochester, N.Y.

Aurora Tool Works, Aurora, Ind.

W. F. & John Barnes Co., Rockford, Ill.

Can. Blower & Forge Co., Kitchener, Ont.

Canada Machinery Corp., Galt, Ont.

Dominion Machy. Co., Toronto, Ont.

Foss & Hill Machy. Co., Montreal.

Garlock-Walker Machinery Co., Toronto, Ont.

Garvin Machine Co., New York.

Montreal Machy. & Supplies, Ltd., Montreal, Que.

Niles-Bement-Pond Co., New York.

Petrie of Montreal, Ltd., H. W., Montreal, Que.

H. W. Petrie, Toronto.

R. E. T. Pringle, Ltd., Toronto, Ont.

Riverside Machinery Depot, Detroit, Mich.

United States Mach. Tool Co., Cincinnati, Ohio.

A. R. Williams Machinery Co., Toronto.

DRILLING MACHINES, BENCH

Bilton Mach. Tool Co., Bridgeport, Conn.

Martin Machine Co., Greenfield, Mass.

DRILLING MACHINES, GANG

Barnes, W. F. & John, Co., Rockford, Ill.

Bilton Mach. Tool Co., Bridgeport, Conn.

Canada Machinery Corp., Galt, Ont.

Silver Mfg. Co., Salem, Ohio.

DRILLING MACHINES, LOCOMOTIVE AND MULTIPLE SPINDLE

John Bertram & Sons Co., Dundas.

Bilton Mach. Tool Co., Bridgeport, Conn.

Can. Blower & Forge Co., Kitchener, Ont.

Canada Machinery Corp., Galt, Ont.

Canadian Fairbanks-Morse Co., Montreal.

Cincinnati Pulley Machy. Co., Cincinnati, Ohio.

Dominion Machy. Co., Toronto, Ont.

Foss & Hill Machy. Co., Montreal.

Fox Machine Co., Jackson, Mich.

Garlock-Walker Machinery Co., Toronto, Ont.

Garvin Machine Co., New York.

A. B. Jardine & Co., Hespeler, Ont.

National-Acme Co., Cleveland, Ohio.

Niles-Bement-Pond Co., New York.

Petrie of Montreal, Ltd., H. W., Montreal, Que.

H. W. Petrie, Toronto.

Rockford Drilling Mach. Co., Rockford, Ill.

DRILLING MACHINES, RADIAL AND TURRET

John Bertram & Sons Co., Dundas.

Canadian Fairbanks-Morse Co., Montreal.

Canada Machinery Corp., Galt, Ont.

Dominion Machy. Co., Toronto, Ont.

Garlock-Walker Machinery Co., Toronto, Ont.

Henry & Wright Mfg. Co., Hartford, Conn.

Mueller Mach. Tool Co., Cincinnati, Ohio.

Niles-Bement-Pond Co., New York.

H. W. Petrie, Toronto.

DRILLING MACHINES, SENSITIVE

Aikenhead Hardware Co., Toronto, Ont.

Bilton Mach. Tool Co., Bridgeport, Conn.

W. F. & John Barnes Co., Rockford, Ill.

Canadian Fairbanks-Morse Co., Montreal.

Canada Machinery Corp., Galt, Ont.

De Mooy Machine Co., Cleveland, Ohio.

Foss & Hill Machy. Co., Montreal.

Garlock-Walker Machinery Co., Toronto, Ont.

Henry & Wright Mfg. Co., Hartford, Conn.

D. McKenzie Machinery Co., Guelph, Ont.

Niles-Bement-Pond Co., New York.

R. E. T. Pringle, Ltd., Toronto, Ont.

Taylor & Feun Co., Hartford, Conn.

United States Mach. Tool Co., Cincinnati, Ohio.

DRILLING MACHINES, UPRIGHT AND HORIZONTAL

Aurora Tool Works, Aurora, Ind.

John Bertram & Sons Co., Dundas.

Can. Blower & Forge Co., Kitchener, Ont.

Canada Machinery Corp., Galt, Ont.

Cincinnati Pulley Machy. Co., Cincinnati, Ohio.

Dominion Machy. Co., Toronto, Ont.

Garlock-Walker Machinery Co., Toronto, Ont.

A. B. Jardine & Co., Hespeler, Ont.

R. McDonald Co., Galt.

Niles-Bement-Pond Co., New York.

Petrie of Montreal, Ltd., H. W., Montreal, Que.

H. W. Petrie, Toronto.

Rockford Drilling Mach. Co., Rockford, Ill.

Silver Mfg. Co., Salem, Ohio.

A. R. Williams Machinery Co., Toronto.

DRILLING POSTS

Aikenhead Hardware Co., Toronto, Ont.

Keystone Mfg. Co., Buffalo, N.Y.

Silver Mfg. Co., Salem, Ohio.

DRILLS, BENCH

Aikenhead Hardware Co., Toronto, Ont.

W. F. & John Barnes Co., Rockford, Ill.

Can. Blower & Forge Co., Kitchener, Ont.

Canadian Fairbanks-Morse Co., Montreal.

Cincinnati Pulley Machy. Co., Cincinnati, Ohio.

Foss & Hill Machy. Co., Montreal.

Garlock-Walker Machinery Co., Toronto, Ont.

Millers Falls Co., Millers Falls, Mass.

H. W. Petrie, Ltd., Montreal.

Pratt & Whitney Co., Dundas, Ont.

R. E. T. Pringle, Ltd., Toronto, Ont.

United States Electrical Tool Co., Cincinnati.

DRILLS, BLACKSMITH AND BIT STOCK

Aikenhead Hardware Co., Toronto, Ont.

Can. Blower & Forge Co., Kitchener, Ont.

Cleveland Twist Drill Co., Cleveland.

Foss & Hill Machy. Co., Montreal.

A. B. Jardine & Co., Hespeler, Ont.

Morse Twist Drill & Machine Co., New Bedford.

Petrie of Montreal, Ltd., H. W., Montreal, Que.

H. W. Petrie, Toronto.

DRILLS, CENTRE

Aikenhead Hardware Co., Toronto, Ont.

Clark Equipment Co., Buchanan, Mich.

Cleveland Twist Drill Co., Cleveland.

Morse Twist Drill & Machine Co., New Bedford.

DRILLS, CORNER (PNEUMATIC)

Can. Ingersoll-Rand Co., Sherbrooke, Que.

Cleveland Pneumatic Tool Co. of Canada, Toronto.

Garlock-Walker Machinery Co., Toronto, Ont.

DRILLS, ELECTRIC AND PORTABLE

Aikenhead Hardware Co., Toronto, Ont.

Can. Blower & Forge Co., Kitchener, Ont.

Dominion Machy. Co., Toronto, Ont.

Foss & Hill Machy. Co., Montreal.

Independent Pneumatic Tool Co., Chicago.

Niles-Bement-Pond Co., New York.

H. W. Petrie, Ltd., Montreal.

H. W. Petrie, Toronto.

Prest-O-Lite Co., Inc., Toronto, Ont.

R. E. T. Pringle, Ltd., Toronto, Ont.

Standard Electrical Tool Co., Cincinnati, Ohio.

Stow Mfg. Co., Binghamton, N.Y.

United States Electrical Tool Co., Cincinnati.

A. R. Williams Machy. Co., Toronto.

DRILLS, HIGH SPEED

Aikenhead Hardware Co., Toronto, Ont.

Atkins & Co., Wm., Sheffield, Eng.

Cleveland Twist Drill Co., Cleveland.

Canadian Fairbanks-Morse Co., Montreal.

Can. B. K. Morton, Toronto, Montreal.

H. A. Dmyr Co., Montreal.

Foss & Hill Machy. Co., Montreal.

Marshall, Geo. A., 70 Lombard St., Toronto.

McKenna Brothers, Pittsburgh, Pa.

Montreal Machy. & Supplies, Ltd., Montreal, Que.

Morse Twist Drill & Mach. Co., New Bedford, Mass.

Osborn (Canada), Ltd., Sam'l, Montreal, Que.

W. F. & John Barnes Co., Rockford, Ill.

H. W. Petrie, Toronto.

Wilt Twist Drill Co., Walkerville, Ont.

Pratt & Whitney Co., Dundas, Ont.

DRILLS, MULTIPLE SPINDLE

Henry & Wright Mfg. Co., Hartford, Conn.

Niles-Bement-Pond Co., New York.

H. W. Petrie, Ltd., Montreal.

Garlock-Walker Machinery Co., Toronto, Ont.

Pratt & Whitney Co., Dundas, Ont.

DRILLS, OIL TUBE

Cleveland Twist Drill Co., Cleveland.

Morse Twist Drill & Mach. Co., New Bedford.

DRILLS, PNEUMATIC

Can. Ingersoll-Rand Co., Sherbrooke, Que.

Cleveland Pneumatic Tool Co. of Canada, Toronto.

Independent Pneumatic Tool Co., Chicago, Ill.

The Jenckes Mach. Co., Ltd., Sherbrooke, Que.

Niles-Bement-Pond Co., New York.

R. E. T. Pringle, Ltd., Toronto, Ont.

DRILLS, PNEUMATIC CORNER

Independent Pneumatic Tool Co., Chicago, Ill.

DRILLS, RATCHET AND HAND

Aikenhead Hardware Co., Toronto, Ont.

Armstrong Bros. Tool Co., Chicago.

Can. Blower & Forge Co., Kitchener, Ont.

Canadian Fairbanks-Morse Co., Montreal.

Cleveland Twist Drill Co., Cleveland.

Garlock-Walker Machinery Co., Toronto, Ont.

A. B. Jardine & Co., Hespeler, Ont.

Millers Falls Co., Millers Falls, Mass.

Morse Twist Drill & Mach. Co., New Bedford.

H. W. Petrie, Ltd., Montreal.

H. W. Petrie, Toronto.

Pratt & Whitney Co., Dundas, Ont.

DRILLS, ROCK

Can. Ingersoll-Rand Co., Sherbrooke, Que.

Cleveland Pneumatic Tool Co. of Canada, Toronto.

Dominion Machy. Co., Toronto.

Foss & Hill Machy. Co., Montreal.

The Jenckes Mach. Co., Ltd., Sherbrooke, Que.

A. R. Williams Machy. Co., Toronto.

DRILLS, TRACK

Cleveland Twist Drill Co., Cleveland.

Foss & Hill Machy. Co., Montreal.

Morse Twist Drill & Mach. Co., New Bedford.

DRILLS, TWIST

Atkins & Co., Wm., Sheffield, Eng.

Aikenhead Hardware Co., Toronto, Ont.

Armstrong, Whitworth of Canada, Ltd., Montreal.

Canadian Fairbanks-Morse Co., Montreal.

Can. B. K. Morton, Toronto, Montreal.

Clark Equipment Co., Buchanan, Mich.

Cleveland Twist Drill Co., Cleveland.

Morse Twist Drill & Mach. Co., New Bedford.

Osborn (Canada), Ltd., Sam'l, Montreal, Que.

H. W. Petrie, Toronto.

Pratt & Whitney Co., Dundas, Ont.

Welborne & Co., New York, N.Y.

Whitman & Barnes Mfg. Co., St. Catharines, Ont.

Wilt Twist Drill Co., Walkerville, Ont.

DRINKING FOUNTAINS

Puro Sanitary Drinking Fountain Co., Haydenville, Mass.

DRYING APPLIANCES

Baird Machine Co., Bridgeport, Conn.

Corbet Fairbanks & Mach. Co., Ltd., Owen Sound, Ont.

Sheldons, Ltd., Galt, Ont.

R. E. T. Pringle, Ltd., Toronto, Ont.

DUMP CARS

Canadian Fairbanks-Morse Co., Montreal.

The Jenckes Mach. Co., Ltd., Sherbrooke, Que.

MacKinnon, Holmes & Co., Sherbrooke, Que.

DUST SEPARATORS

Can. Blower & Forge Co., Kitchener, Canada.

Sheldons, Ltd., Galt, Ont.

DUST ARRESTERS (FOR TUMBLING MILLS)

Northern Crane Works, Walkerville.

Sheldons, Ltd., Galt, Ont.

Sturtevant Co., B. F., Galt, Ont.

Whiting Foundry Equipment Co., Harvey, Ill.

DYNAMOS AND ELECTRICAL SUPPLIES

Canadian Fairbanks-Morse Co., Montreal.

Dominion Machy. Co., Toronto, Ont.

Lancashire Dynamo & Motor Co., Ltd., Toronto.

Montreal Machy. & Supplies, Ltd., Montreal, Que.

Petrie of Montreal, Ltd., H. W., Montreal, Que.

H. W. Petrie, Toronto.

A. R. Williams Machy. Co., Toronto.

Pratt & Whitney Co., Dundas, Ont.

ELEVATOR ENCLOSURES

Canada Wire & Iron Goods Co., Hamilton, Ont.

Dennis Wire & Iron Works, London, Ont.

ELEVATORS AND BUCKETS

Curtis Pneumatic Machy. Co., St. Louis, Mo.

Whiting Foundry Equipment Co., Harvey, Ill.

ELEVATING AND CONVEYING MACHINERY

Banfield, Edwin J., Toronto.

Can. Matthews Gravity Carrier Co., Toronto, Ont.

EMERY GRINDERS (PNEUMATIC)

Cleveland Pneumatic Tool Co. of Canada, Toronto.

Stow Mfg. Co., Binghamton, N.Y.

EMERY AND EMERY WHEELS

Foss & Hill Machy. Co., Montreal.

Garvin Machine Co., New

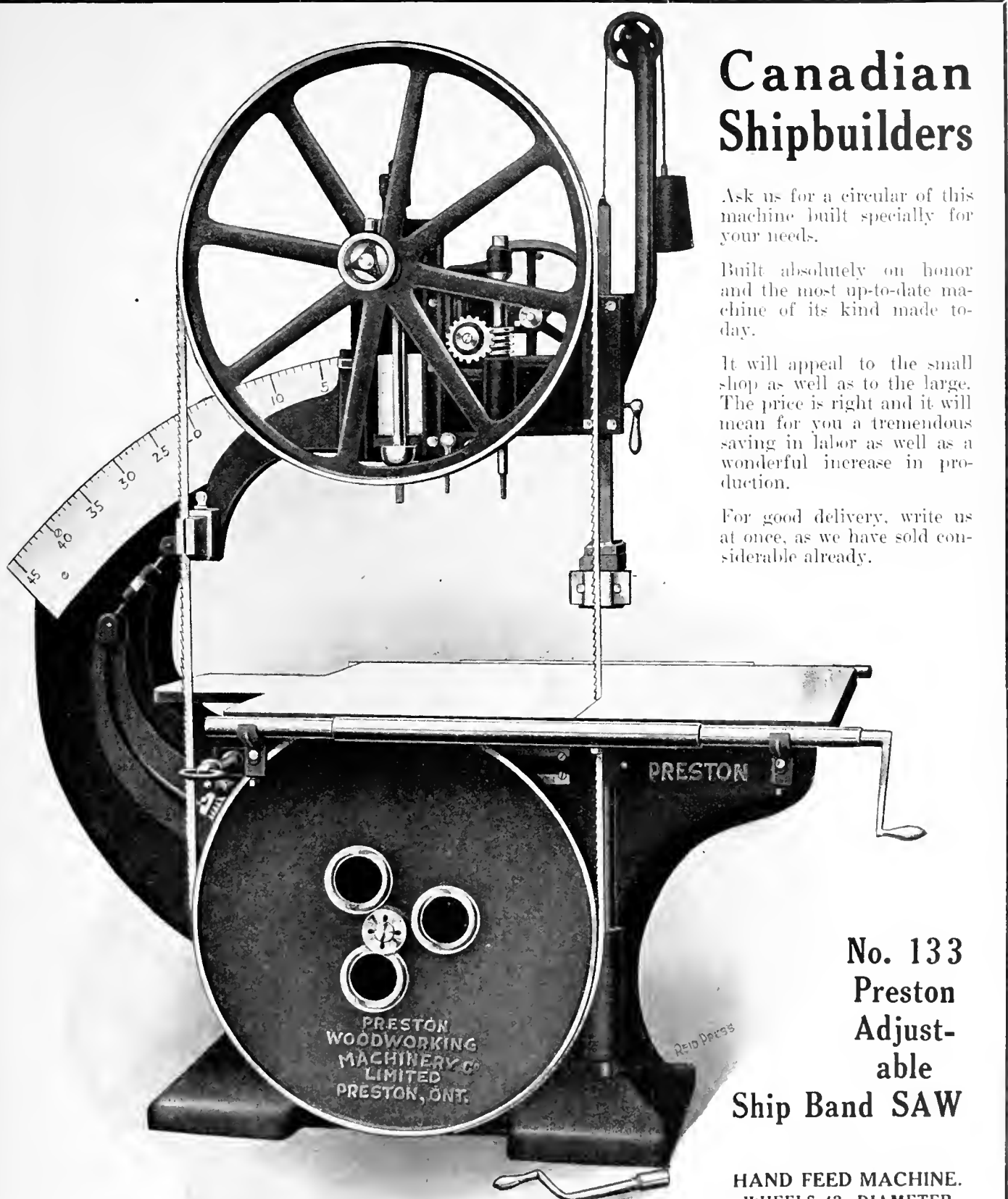

Canadian Shipbuilders

Ask us for a circular of this machine built specially for your needs.

Built absolutely on honor and the most up-to-date machine of its kind made to-day.

It will appeal to the small shop as well as to the large. The price is right and it will mean for you a tremendous saving in labor as well as a wonderful increase in production.

For good delivery, write us at once, as we have sold considerable already.

**No. 133
Preston
Adjust-
able
Ship Band SAW**

**HAND FEED MACHINE.
WHEELS 42 DIAMETER
ANGLES 45° TO LEFT AND
10° TO RIGHT.**

FOR POWER FEED MACHINE, SEE CIRCULAR NO. 134

The Preston Woodworking Machinery Co., Limited, Preston, Ont.

SALES AGENTS: A. R. WILLIAMS MACHINERY COMPANY, ST. JOHN, VANCOUVER AND TORONTO

If any advertisement interests you, tear it out now and place with letters to be answered.

FILES

Aikenhead Hardware Co., Toronto, Ont.
 Atkins & Co., Wm., Sheffield, Eng.
 Can. B. K. Morton Co., Toronto, Ont.
 Delta File Works, Philadelphia, Pa.
 Marshall, Geo. A., 70 Lombard St., Toronto.
 Montreal Machy. & Supplies, Ltd., Montreal, Que.
 Nicholson File Co., Port Hope, Ont.
 Osborn (Canada), Ltd., Sam'l, Montreal, Que.
 Port Hope File Mfg. Co., Port Hope, Ont.

FILING MACHINES

Noble & Westbrook Mfg. Co., Hartford, Conn.

FILTERS, WATER

W. B. Scaife & Sons, Pittsburgh, Pa.

FIRE ESCAPES

Canada Wire & Iron Goods Co., Hamilton, Ont.
 Corbet Fdry. & Mach. Co. Ltd., Owen Sound, Ont.

FIRE EXTINGUISHERS

Strong, Kennard & Nutt Co., Cleveland, Ohio.

FIRST AID CABINETS

Strong, Kennard & Nutt Co., Cleveland, Ohio.

FISH PLATES

Can. Steel Foundries, Ltd., Montreal, Que.

FIXTURES

Goddard Tool Co., Chicago, Ill.
 Monarch Brass Mfg. Co., Toronto, Ont.
 Slocum, Avram & Slocum, Inc., New York.

FLEXIBLE SHAFTS

R. E. T. Pringle, Ltd., Toronto, Ont.
 Stow Mfg. Co., Binghamton, N.Y.

FORGES, HAND, PORTABLE

Aikenhead Hardware Co., Toronto, Ont.
 Can. Blower & Forge Co., Kitchener, Canada
 Sheldons, Ltd., Galt, Ont.

FORGINGS, DROP, AUTOMOBILE**AND LOCOMOTIVE**

Bliss, E. W., Co., Brooklyn, N.Y.
 Can. Billings & Spencer, Ltd., Welland, Ont.
 Cumming & Son, J. W., New Glasgow, Canada.
 Dom. Forge & Stg. Co., Walkerville, Ont.
 Steel Co. of Canada, Ltd., Hamilton, Ont.
 Whitman & Barnes Mfg. Co., St. Catharines, Ont.
 J. H. Williams & Co., Brooklyn, N.Y.

FORGING HAMMERS, BELT-DRIVEN

Bliss, E. W., Co., Brooklyn, N.Y.
 J. H. Williams & Co., Brooklyn, N.Y.

FORGING HAMMERS, STEAM OR AIR

Erie Foundry Co., Erie, Pa.

FORGING MACHINERY

John Bertram & Sons Co., Dundas.
 Bliss, E. W., Co., Brooklyn, N.Y.
 Brown, Bross Co., Ltd., Hamilton, Canada.
 Erie Foundry Co., Erie, Pa.
 Garlock-Walker Machinery Co., Toronto, Ont.
 National Machinery Co., Tiffin, Ohio.
 Petrie of Montreal, Ltd., H. W., Montreal, Que.
 H. W. Petrie, Toronto.

FUEL OIL SYSTEMS

Gilbert & Barker Mfg. Co., Springfield, Mass.

FRICTION LEATHERS

Graton & Knight Mfg. Co., Montreal.

FURNACES, ANNEALING, ETC.

Can. Hoskins, Ltd., Walkerville, Ont.
 Gilbert & Barker Mfg. Co., Springfield, Mass.
 Mechanical Engineering Co., Montreal.
 Rockwell Co., W. S., New York, N.Y.
 Tate-Jones & Co., Leesdale, Pa.
 Whiting & Co., Harvey, Ill.

FURNACE, RAST

Toronto Iron Works, Ltd., Toronto.

FURNACES, BRASS, MALLEABLE

Whiting Foundry Equipment Co., Harvey, Ill.

FURNACES, HEAT TREATING

Can. Hoskins, Ltd., Walkerville, Ont.

HARDENING AND TEMPERING

Gilbert & Barker Mfg. Co., Springfield, Mass.

Tate-Jones & Co., Leesdale, Pa.

Montreal Machy. & Supplies, Ltd., Montreal, Que.

FURNACES, FORGING

Can. Hoskins, Ltd., Walkerville, Ont.

Gilbert & Barker Mfg. Co., Springfield, Mass.

FURNACES FOR BAKING, BLUING,

DRYING, ENAMELING, JAPANING

AND LACQUERING

Can. Hoskins, Ltd., Walkerville, Ont.

Oven Equipment & Mfg. Co., New Haven, Conn.

FUSE BOXES, STEEL

Dom. Forge & Stg. Co., Walkerville, Ont.

FUSE CAP MACHINERY

Noble & Westbrook Mfg. Co., Hartford, Conn.

GALVANIZING MACHINERY

Erie Foundry Co., Erie, Pa.

GANG PLANNER TOOLS

Armstrong Bros. Tool Co., Chicago.

GASKETS, LEATHER, ETC.

Graton & Knight Mfg. Co., Montreal.

GASKETS, COPPER

Hungerford Brass & Copper Co., New York, N.Y.

GAS BLOWERS AND EXHAUSTERS

Can. Blower & Forge Co., Kitchener, Ont.

Sheldons, Limited, Galt.

GAUGES, MERCURY COLUMN, DRAFT

Charles F. Elmes Eng. Works, Chicago.

GAUGES, HYDRAULIC

Taylor Instrument Co., Rochester, N.Y.

GAUGES, STANDARD

Can. Fairbanks-Morse Co., Montreal.

Cleveland Twist Drill Co., Cleveland.

Garvin Machine Co., New York.

Illinois Tool Works, Chicago, Ill.

Goddard Tool Co., Chicago, Ill.

Morse Twist Drill & Machine Co., New Bedford.

Osborn (Canada), Ltd., Sam'l, Montreal, Que.

Pratt & Whitney Co., Hartford, Conn.

Slocum, Avram & Slocum, Inc., New York.

Swedish Gage Co., Montreal, Que.

Toronto Tool Works, Toronto, Ont.

Wells Brothers Co. of Canada, Galt, Ont.

Worth Engineering Co., Toronto, Ont.

GEAR BLANKS

Can. Steel Foundries, Ltd., Montreal, Que.
 Lyman Tube & Supply Co., Montreal, Que.
 Webber Bros. Mach. Co., Toronto, Ont.

GEAR-CUTTING MACHINERY

Bilton Mach. Tool Co., Bridgeport, Conn.
 Dominion Machinery Co., Toronto.
 Garlock-Walker Machinery Co., Toronto, Ont.
 Hamilton Gear & Machine Co., Toronto.
 H. W. Petrie, Ltd., Montreal.
 H. W. Petrie, Toronto.

The Smart-Turner Machine Co., Hamilton.

D. E. Whiton Machine Co., New London, Conn.

A. R. Williams Machy. Co., Toronto.

GEAR TURNING MACHINES, BEND

Bridgeford Mach. Tool Works, Rochester, N.Y.

GEARS, CUT, MORTISE, ANGLE, WORM

Baxter Co., Ltd., J. R., Montreal, Que.
 Corbet Fdry. & Mach. Co., Ltd., Owen Sound, Ont.
 Gardner, Robt., & Son, Montreal.
 Grant Gear Works, Boston, Mass.
 Hamilton Gear & Machine Co., Toronto.
 Hull Iron & Steel Foundries, Ltd., Hull, Que.
 The Jencks Mach. Co., Ltd., Sherbrooke, Que.
 Wm. K. Kennedy & Sons, Ltd., Owen Sound, Ont.
 Philadelphia Gear Works, Philadelphia, Pa.
 The Smart-Turner Machine Co., Hamilton.
 Winnipeg Gear & Engr. Co., Winnipeg, Man.

GEARS, RAWHIDE

Hamilton Gear & Machine Co., Toronto.
 Gardner, Robt., & Son, Montreal.
 Grant Gear Works, Boston, Mass.
 Philadelphia Gear Works, Philadelphia, Pa.
 A. R. Williams Machy. Co., Toronto.
 Winnipeg Gear & Engr. Co., Winnipeg, Man.

GENERATORS, ELECTRIC

Can. Fairbanks-Morse Co., Montreal.
 Dominion Machinery Co., Toronto, Ont.
 Lancashire Dynamo & Motor Co., Toronto.
 H. W. Petrie, Ltd., Montreal.
 H. W. Petrie, Toronto.
 S. Ormiston Co., B. F., Galt, Ont.
 Wilson's Brothers, Saginaw, Mich.
 A. R. Williams Machy. Co., Toronto.

GLASSES, SAFETY

Strong, Kennard & Nutt Co., Cleveland, Ohio.
 Willson & Co., Inc., T. A., Reading, Pa.

GRAIN POLISHING

Norton Co., Worcester, Mass.

GRAPHITE

Aikenhead Hardware Co., Toronto, Ont.
 Montreal Machy. & Supplies, Ltd., Montreal, Que.

GLOVES, LEATHER AND RUBBER

Strong, Kennard & Nutt Co., Cleveland, Ohio.

GLOVES, STEEL, GRIP

Hickory Steel Grip Glove Co., Chicago, Ill.

GRAVITY CARRIERS

Can. Mathews Gravity Carrier Co., Toronto, Ont.

GREASES (SEE LUBRICANTS)

GRINDER ATTACHMENTS
 Bayett Lathe & Grinder Co., Boston, Mass.
 Wilmarth & Morman, Grand Rapids, Mich.

GRINDERS, AUTOMATIC KNIFE

W. H. Banfield & Son, Toronto.
 Canada Machinery Corp., Galt, Ont.
 Foss & Hill Machy. Co., Montreal.
 Garlock-Walker Machinery Co., Toronto, Ont.

GRINDERS, CENTRE, PEDESTAL

AND BENCH
 Parkey Brothers, Stouffville, Ont.
 Blake & Johnson Co., Waterbury, Conn.
 Can. Bond Hanger & Cplg. Co., Alexandria, Ont.
 Canada Machinery Corp., Galt, Ont.
 Cleveland Pneumatic Tool Co. of Canada, Toronto.
 Dominion Machy. Co., Toronto, Ont.
 Ford-Smith Mach. Co., Hamilton, Ont.
 Foss & Hill Machy. Co., Montreal.
 Garlock-Walker Machinery Co., Toronto, Ont.
 Niles-Bement-Pond Co., New York.
 Modern Tool Co., Erie, Pa.
 Morse Twist Drill & Machine Co., New Bedford.
 New Britain Machine Co., New Britain, Conn.
 H. W. Petrie, Ltd., Montreal.
 H. W. Petrie, Toronto.
 R. E. T. Pringle, Ltd., Toronto, Ont.
 Slocum, Avram & Slocum, Inc., New York.
 Standard Electrical Tool Co., Cincinnati, Ohio.
 Stow Mfg. Co., Binghamton, N.Y.
 United States Electrical Tool Co., Cincinnati, O.

GRINDERS, COLUMN

Parkey Brothers, Stouffville, Ont.

GRINDERS, CUTTER

Brown & Sharpe Mfg. Co., Providence, R.I.
 Foss & Hill Machy. Co., Montreal.
 Greenfield Machine Co., Greenfield, Mass.
 LeBlond Mach. Tool Co., R. K., Cincinnati, O.
 Norton Grinding Co., Worcester, Mass.
 Pratt & Whitney Co., Dundas, Ont.
 Wilmarth & Morman, Grand Rapids, Mich.

GRINDERS, DIE AND CHASER

Landis Machine Co., Waynesboro, Pa.
 Modern Tool Co., Erie, Pa.
 National-Acme Co., Cleveland, Ohio.

GRINDERS, DISK

Armstrong Bros. Tool Co., Chicago, Ill.
 Ford-Smith Mach. Co., Hamilton, Ont.
 Gardner Machine Co., Beloit, Wis.

GRINDERS, DRILL

Aikenhead Hardware Co., Toronto, Ont.
 Foss & Hill Machy. Co., Montreal.
 Garvin Machine Co., New York.

Standard Electrical Co., Cincinnati, Ohio.
 United States Electrical Tool Co., Cincinnati, O.
 Wilmarth & Morman, Grand Rapids, Mich.

GRINDERS, CYLINDER, INTERNAL

Brown & Sharpe Mfg. Co., Providence, R.I.
 Fitchburg Grinding Mach. Co., Fitchburg, Mass.
 Foss & Hill Machy. Co., Montreal.
 Fraser Co., Warren, Mass., Boston, Mass.
 Greenfield Machine Co., Greenfield, Mass.
 Modern Tool Co., Erie, Pa.
 Norton Grinding Co., Worcester, Mass.

R. E. T. Pringle, Ltd., Toronto, Ont.
 Bayett Lathe & Grinder Co., Brighton, Mass.

Standard Electrical Tool Co., Cincinnati, Ohio.

GRINDERS, PNEUMATIC

Can. Ingersoll-Rand Co., Sherbrooke, Que.
 Cleveland Pneumatic Tool Co. of Canada, Toronto.
 Garlock-Walker Machinery Co., Toronto, Ont.
 Independent Pneumatic Tool Co., Chicago, Ill.

GRINDERS, PRECISION

Slocum, Avram & Slocum, Inc., New York.

GRINDERS, PORTABLE, ELECTRIC,

HAND, TOOL POST, FLOOR AND BENCH
 Baird Machine Co., Bridgeport, Conn.
 Brown & Sharpe Mfg. Co., Providence, R.I.
 Can. Bond Hanger & Cplg. Co., Alexandria, Ont.
 Dominion Machy. Co., Toronto, Ont.
 Ford-Smith Mach. Co., Hamilton, Ont.
 Foss & Hill Machy. Co., Montreal.
 Grant Mfg. & Machine Co., Bridgeport, Conn.
 Garlock-Walker Machinery Co., Toronto, Ont.
 Greenfield Machine Co., Greenfield, Mass.
 Independent Pneumatic Tool Co., Chicago.
 Norton Co., Worcester, Mass.
 Petrie of Montreal, Ltd., H. W., Montreal, Que.
 H. W. Petrie, Toronto.
 R. E. T. Pringle, Ltd., Toronto, Ont.
 Standard Electrical Tool Co., Cincinnati, Ohio.
 United States Electrical Tool Co., Cincinnati, O.
 A. R. Williams Machy. Co., Toronto.

GRINDERS, RADIAL

Bayett Lathe & Grinder Co., Brighton, Mass.

GRINDERS, TOOL AND HOLDER

Armstrong Bros. Tool Co., Chicago.
 W. F. & John Barnes Co., Rockford, Ill.
 Blake & Johnson Co., Waterbury, Conn.
 Blount, J. G., & Co., Everett, Mass.
 Brown & Sharpe Mfg. Co., Providence, R.I.
 Taylor & Fenn Co., Hartford, Conn.
 Greenfield Machine Co., Greenfield, Mass.
 National-Acme Co., Cleveland, Ohio.
 H. W. Petrie, Ltd., Montreal.
 Talor Mfg. Co., Philadelphia, Pa.
 Wing & Son, J. E., Hamilton, Ont.

GRINDERS, UNIVERSAL, PLAIN

Fitchburg Grinding Machine Co., Fitchburg, Mass.
 Fraser Co., Warren, Mass., Boston, Mass.
 Modern Tool Co., Erie, Pa.
 Wilmarth & Morman, Grand Rapids, Mich.

GRINDERS, VERTICAL SURFACE
 Brown & Sharpe Mfg. Co., Providence, R.I.
 Can. Fairbanks-Morse Co., Montreal.
 Fraser Co., Warren, Mass., Boston, Mass.
 Pratt & Whitney Co., Dundas, Ont.
 Wilmarth & Morman, Grand Rapids, Mich.
 Wing & Son, J. E., Hamilton, Ont.

GRINDING AND POLISHING
MACHINES, PORTABLE, PNEUMATIC
AND SPRING FRAME
 Can. Fairbanks-Morse Co., Montreal.
 Ford-Smith Mach. Co., Hamilton, Ont.
 Gardner, Robt., & Son, Montreal.
 Garvin Machine Co., New York.
 Garlock-Walker Machinery Co., Toronto, Ont.
 Greenfield Machine Co., Greenfield, Mass.
 Hall & Sons, John H., Brantford.
 LeBlond Mach. Tool Co., R. K., Cincinnati.
 Niles-Bement-Pond Co., New York.
 Petrie of Montreal, Ltd., H. W., Montreal, Que.
 H. W. Petrie, Toronto.
 Wilmarth & Morman, Grand Rapids, Mich.
 Stow Mfg. Co., Binghamton, N.Y.

GRINDING WHEELS
 Aikenhead Hardware Co., Toronto, Ont.
 Baxter Co., Ltd., J. R., Montreal, Que.
 Can. Hart Wheels, Ltd., Hamilton, Ont.
 Can. Fairbanks-Morse Co., Montreal.
 Can. B. K. Morton, Toronto, Montreal.
 Carborundum Co., Niagara Falls.
 Dominion Abrasive Wheel Co., New Toronto, Ont.
 Ford-Smith Mach. Co., Hamilton, Ont.
 Foss & Hill Machy. Co., Montreal.
 Francis & Co., Hartford, Conn.
 Norton Co., Worcester, Mass.
 H. W. Petrie, Toronto.

GUARDS WINDOW AND MACHINE
 Canada Wire & Iron Goods Co., Hamilton, Ont.
 New Britain Mach. Co., New Britain, Conn.

HACK SAW BLADES
 Aikenhead Hardware Co., Toronto, Ont.
 Baxter Co., Ltd., J. R., Montreal, Que.
 Diamond Saw & Stamping Works, Buffalo, N.Y.
 Foss & Hill Machy. Co., Montreal.
 Gould-Pratt, Greenfield, Mass.
 Millers Falls Co., Millers Falls, Mass.
 Montreal Machy. & Supplies, Ltd., Montreal, Que.
 Osborn (Canada), Ltd., Sam'l, Montreal, Que.
 H. W. Petrie, Ltd., Montreal.
 Racine Tool & Machine Co., Racine, Wis.
 L. S. Starrett Co., Athol, Mass.
 Venth Saw Works, Ltd., Hamilton, Canada.
 Zurich Tool & Steel Products, Montreal, Que.

HACK SAW FRAMES
 Aikenhead Hardware Co., Toronto, Ont.
 Garvin Machine Co., New York City.
 Gould-Pratt, Greenfield, Mass.
 Millers Falls Co., Millers Falls, Mass.

HAMMERS, AIR
 Erie Foundry Co., Erie, Pa.

HAMMERS, COPPER
 Hungerford Brass & Copper Co., New York, N.Y.

HAMMERS, DROP AND BELT-DRIVEN
 Beauty & Co., Boston, Mass.
 Bliss, E. W., Co., Brooklyn, N.Y.
 Brown, Bross Co., Ltd., Hamilton, Canada.
 Canadian Billings & Spencer, Ltd., Welland.
 Canada Machinery Corp., Galt, Ont.
 Erie Foundry Co., Erie, Pa.
 High Speed Hammer Co., Rochester, N.Y.
 A. B. Jardine & Co., Hespeler, Ont.
 Niles-Bement-Pond Co., New York.
 Plessisville Foundry Co., Plessisville, Que.
 Toledo Machine & Tool Co., Toledo.
 United Hammer Co., Boston, Mass.

MACKINTOSH, HEMPHILL & CO.

PITTSBURGH, PA., U.S.A.

DESIGNERS AND BUILDERS OF

Heavy Rolling Mills

Steel and Manganite Rolls

Engines and Steel Work Equipment

The

B
A
R
N
E
S



D
R
I
L
L
S

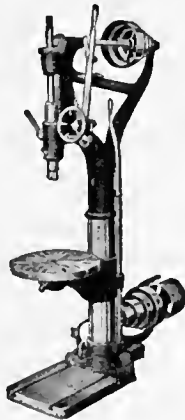

Complete line. 8-inch to 50-inch swing
Gang Drills.—Horizontal Drills.

SEND FOR CATALOG.

W. F. & JOHN BARNES CO.

104 Ruby Street - ROCKFORD, ILL.

Canadian Agents—A. R. WILLIAMS MACHINERY CO.

Toronto, Winnipeg, Vancouver, and St. John, N.B.

WILLIAMS & WILSON, Montreal

Production of Rare Quality at Lowest Labor Costs

There is unusual strength,
accuracy, speed, conven-
ience and range in

AURORA Drilling Machines

You can use them
to great advant-
age on **HIGH
EXPLOSIVE
SHELLS** or any
work in your shop
that's suitable for
a machine tool of
this kind. The
operating is easy
and the labor cost
comparatively
low.



Drop a line for full particulars and specifications.

Stationary Head Sizes 20"—21"

Sliding Head Sizes 22"—44"

The Aurora Tool Works Aurora, Indiana

If any advertisement interests you, tear it out now and place with letters to be answered.

- HAMMERS, HELVE POWER**
Canada Machinery Corp., Galt, Ont.
West Tire Setter Co., Rochester, N.Y.
- HAMMERS, POWER**
Beandry & Co., Boston, Mass.
Eric Foundry Co., Erie, Pa.
United Hammer Co., Boston, Mass.
- HAMMERS, CHIPPING, CAULKING, PNEUMATIC**
Can. Ingersoll-Rand Co., Sherbrooke, Que.
Cleveland Pneumatic Tool Co. of Canada, Toronto.
Garlock-Walker Machinery Co., Toronto, Ont.
Independent Pneumatic Tool Co., Chicago, Ill.
R. E. T. Pringle, Ltd., Toronto, Ont.
- HAMMERS, MARKING**
Matthews, Jas. H. & Co., Pittsburgh, Pa.
Pamier Bros. Stamp Co., Pittsburgh, Pa.
- HAMMERS, MOTOR-DRIVEN**
Beandry & Co., Boston, Mass.
United Hammer Co., Boston, Mass.
- HAMMERS, NAIL MACHINES**
Whitman & Barnes Mfg. Co., St. Catharines, Ont.
- HAMMERS, STEAM**
John Bertram & Sons Co., Dundas.
Canada Machinery Corp., Galt, Ont.
Eric Foundry Co., Erie, Pa.
Niles-Bement-Pond Co., New York.
- HAND LEATHERS OR PADS**
Graton & Knight Mfg. Co., Montreal.
- HANGERS, SHAFT**
Baird Machine Co., Bridgeport, Conn.
Can. Bond Hanger & Cnlg. Co., Alexandria, Ont.
Can. S K F Co., Toronto, Ont.
Gardner, Robt. & Son, Montreal.
Petrie of Montreal, Ltd., H. W., Montreal, Que.
H. W. Petrie, Toronto.
Standard Pressed Steel Co., Philadelphia, Pa.
- HARDENING AND TEMPERING**
Osborn (Canada), Ltd., Sam'l, Montreal, Que.
- HARDNESS TESTING INSTRUMENTS**
Shore Instrument & Mfg. Co., New York.
- HEATERS AND PURIFIERS**
Scaife & Sons Co., Wm. B., Pittsburgh, Pa.
- HEATING AND VENTILATING ENGINEERS**
Can. Blower & Forge Co., Kitchener, Ont.
Sheldons, Ltd., Galt, Ont.
- HEAT GAUGES, HARDENING AND ANNEALING**
Shore Instrument & Mfg. Co., New York.
- HIGH SPEED TOOL METAL**
DeLoro Smelting & Refining Co., Toronto, Ont.
- HINGE MACHINERY**
Baird Machine Co., Bridgeport, Conn.
- HINGES**
London Bolt & Hinge Works, London, Ont.
- HOBBS**
Illinois Tool Works, Chicago, Ill.
Goddard Tool Co., Chicago, Ill.
Osborn (Canada, Ltd., Sam'l), Montreal, Que.
- HOISTING AND CONVEYING MACHINERY**
Can. Matthews Gravity Carrier Co., Toronto, Ont.
Jenckes Mach. Co., Sherbrooke, Que.
Marsh & Henthorn, Belleville, Ont.
Northern Crane Works, Walkerville, Ont.
Petrie of Montreal, Ltd., H. W., Montreal, Que.
Whiting Foundry Equipment Co., Harvey, Ill.
- HOISTS, CHAIN, ELECTRIC AND PNEUMATIC**
Can. Ingersoll-Rand Co., Sherbrooke, Que.
Garlock-Walker Machinery Co., Toronto, Ont.
Ford Chain Block & Mfg., Philadelphia, Pa.
Independent Pneumatic Tool Co., Chicago, Ill.
Jenckes Mach. Co., Sherbrooke, Que.
Marsh & Henthorn, Belleville, Ont.
Northern Crane Works, Walkerville, Ont.
Whiting Foundry Equipment Co., Harvey, Ill.
- HOISTS, ELECTRIC**
The Jenckes Mach. Co., Ltd., Sherbrooke, Que.
Kennedy & Sons, Owen Sound, Ont.
Northern Crane Works, Walkerville, Ont.
Winnipeg Gear & Engrg. Co., Winnipeg, Man.
Wright Mfg. Co., Lishon, Ohio.
- HOLDERS, STEEL DIE FOR MARKING**
Matthews, Jas. H. & Co., Pittsburgh, Pa.
- HOPPERS**
The Jenckes Mach. Co., Ltd., Sherbrooke, Que.
Toronto Iron Works, Ltd., Toronto, Ont.
- HOSE, PNEUMATIC**
Cleveland Pneumatic Tool Co. of Canada, Toronto.
Garlock-Walker Machinery Co., Toronto, Ont.
Dunlop Tire & Rubber Goods Co., Ltd., Toronto, Ont.
Goodyear Tire & Rubber Co., Toronto, Ont.
Independent Pneumatic Tool Co., Chicago, Ill.
Wells Bros. Co. of Canada, Galt, Ont.
- HOLDERS FOR DIES AND DRILLS**
- HYDRAULIC MACHINERY**
Dominion Machinery Co., Toronto.
Charles F. Elmes Eng. Works, Chicago.
Garlock-Walker Machinery Co., Toronto, Ont.
Niles-Bement-Pond Co., New York.
William B. Perrin, Ltd., Toronto.
H. W. Petrie, Toronto.
West Tire Setter Co., Rochester, N.Y.
- IMPELLERS**
Ontario Specialties, Ltd., Ottawa, Ont.
- INDICATORS, SPEED**
Aikenhead Hardware Co., Toronto, Ont.
Brown & Sharpe Mfg. Co., Providence, R.I.
Goodell Pratt, Greenfield, Mass.
L. S. Starrett Co., Athol, Mass.
- INDEX CENTRES**
Fred C. Dickow, Chicago, Ill.
Garvin Machine Co., New York.
- INDICATING INSTRUMENTS**
Taylor Instrument Co., Rochester, N.Y.
- INGOT METALS**
Samuel, Benjamin & Co., M. L., Toronto, Ont.
- IRON ORE**
Hanna & Co., M. A., Cleveland, O.
- JACKS**
Aikenhead Hardware Co., Toronto, Ont.
Can. Fairbanks-Morse Co., Montreal.
Northern Crane Works, Walkerville, Ont.
Norton, A. O., Coaticook, Que.
Petrie, H. W., Toronto, Ont.
- JACKS, HYDRAULIC**
Charles F. Elmes Eng. Works, Chicago.
- JACKS, PNEUMATIC**
Northern Crane Works, Walkerville, Ont.
- JACKS, PIT AND TRACK**
Can. Fairbanks-Morse Co., Montreal.
Northern Crane Works, Walkerville, Ont.
- JAWS, FACE PLATE**
Cushman Chuck Co., Hartford, Conn.
Skinner Chuck Co., New Britain, Conn.
- JIGS, TOOLS, ETC.**
Goddard Tool Co., Chicago, Ill.
Homer & Wilson, Hamilton, Ont.
Osborn (Canada), Ltd., Sam'l, Montreal, Que.
Toronto Tool Co., Toronto, Ont.
Stocum, Avram & Stocum, Inc., New York.
- KEY SEATERS**
Garlock-Walker Machinery Co., Toronto, Ont.
Garvin Machine Co., New York.
Merton Mfg. Co., Muskegon Heights, Mich.
National Mach. Tool Co., Cincinnati, Ohio.
A. R. Williams Machy. Co., Toronto.
- KEYS, MACHINE**
Whitney Mfg. Co., Hartford, Conn.
- KILNS**
Caa Blower & Forge Co., Kitchener, Ont.
The Jenckes Mach. Co., Ltd., Sherbrooke, Que.
Sheldons, Limited, Galt, Ont.
- LABELS AND TAGS**
Matthews, Jas. H. & Co., Pittsburgh, Pa.
- LABORATORIES, INSPECTION AND TESTING (SEE CHEMISTS)**
- LADLES, FOUNDRY**
Northern Crane Works, Walkerville, Ont.
Whiting Foundry Equipment Co., Harvey, Ill.
- LAG SCREW GIMLET POINTERS**
National Machy. Co., Tiffin, Ohio.
- LATHES, CHUCKING**
Acme Machine Tool Co., Cincinnati, Ohio.
Hyde Engineering Works, Montreal.
- LATHE CHUCKS (SEE CHUCKS)**
- LATHE DOGS AND ATTACHMENTS**
Armstrong Bros. Tool Co., Chicago.
Curtis & Curtis Co., Bridgeport, Conn.
Hendey Machine Co., Torrington, Conn.
Rivett Lathe & Grinder Co., Boston, Mass.
J. H. Williams & Co., Brooklyn, N.Y.
Winnipeg Gear & Engrg. Co., Winnipeg, Man.
- LATHES, AXLE**
Bridgeford Mach. Tool Works, Rochester, N.Y.
- LATHES, PRECISION, BENCH**
W. F. & John Barnes Co., Rockford.
Rieuni, J. G., & Co., Everett, Mass.
Can. Fairbanks-Morse Co., Montreal.
Foss & Hill Machy. Co., Montreal.
Garlock-Walker Machinery Co., Toronto, Ont.
Hardinge Bros., Chicago, Ill.
New Britain Mach. Co., New Britain, Conn.
Petrie & Whitney Co., Dundas, Ont.
Rivett Lathe & Grinder Co., Brighton, Mass.
Walcott Lathe Co., Jackson, Mich.
- LATHES, BAND TURNING**
The Jenckes Mach. Co., Ltd., Sherbrooke, Que.
Reelston Machine & Tool Co., Toronto, Ont.
Warden King Co., Montreal, Que.
- LATHES, BRASS**
Acme Machine Tool Co., Cincinnati, Ohio.
- LATHES, ENGINE**
Acme Machine Tool Co., Cincinnati, Ohio.
Adams, O. R., 159 St. Paul St. Rochester, N.Y.
John Bertram & Sons Co., Dundas.
Bridgeford Mach. Tool Works, Rochester, N.Y.
Canada Machinery Corp., Galt, Ont.
Can. Fairbanks-Morse Co., Montreal.
Cincinnati Iron & Steel Co., Cincinnati, Ohio.
Dominion Machinery Co., Toronto.
Foss & Hill Machy. Co., Montreal.
Garlock-Walker Machinery Co., Toronto, Ont.
Garvin Machine Co., New York.
Hamilton Mach. Tool Co., Hamilton, Ohio.
Hendey Machine Co., Torrington, Conn.
Trifford Machine Co., New York.
Houston, Stanwood & Gamble Co., Cincinnati, O.
Hyde Engineering Works, Montreal.
McCabe, J. J., New York, N.Y.
P. McDougall Co., Galt.
Montreal Machy. & Supplies Ltd., Montreal, Que.
Muller Mach. Tool Co., Cincinnati, Ohio.
Niles-Bement-Pond Co., New York.
Oliver Machinery Co., Grand Rapids, Mich.
H. W. Petrie, Toronto.
Preston Woodworking Machy. Co., Preston, Ont.
Rivett Lathe & Grinder Co., Boston, Mass.
Riverside Machinery Depot, Detroit, Mich.
Walcott Lathe Co., Jackson, Mich.
Whitcomb-Blaisdell Mach. Tool Co., Worcester, Mass.
Sebastian Lathe Co., Cincinnati, Ohio.
Wickes Bros., Saginaw, Mich.
A. R. Williams Machy. Co., Toronto.
- LATHES, JOURNAL TRUEING**
Bridgeford Mach. Tool Works, Rochester, N.Y.
McCabe, J. J., New York, N.Y.
- LATHES, PATTERNMAKERS'**
J. G. Blount Co., Everett, Mass.
Canada Machinery Corp., Galt, Ont.
Foss & Hill Machy. Co., Montreal.
Garlock-Walker Machy. Co., Toronto, Ont.
Jenckes Mach. Co., Sherbrooke, Que.
McCabe, J. J., New York, N.Y.
H. W. Petrie, Ltd., Montreal.
H. W. Petrie, Toronto.
- LATHES, SINGLE PURPOSE**
Bertram, John, & Sons Co., Dundas, Ont.
Canada Machinery Corp., Galt, Ont.
Can. Fairbanks-Morse Co., Montreal, Que.
Garlock-Walker Machinery Co., Toronto, Ont.
Gray Mfg. & Mach. Co., Toronto, Ont.
Hepburn, John T., Ltd., Toronto, Ont.
Hindof Machine Co., Inc., New York, N.Y.
The Jenckes Mach. Co., Ltd., Sherbrooke, Que.
McCabe, J. J., New York, N.Y.
Reelston Mach. & Tool Co., Toronto, Can.
Walcott Lathe Co., Jackson, Mich.
- LATHES, SCREW CUTTING**
John Bertram & Sons Co., Dundas.
Canada Machinery Corp., Galt, Ont.
Dominion Machinery Co., Toronto.
Foss & Hill Machy. Co., Montreal.
Foster Machine Co., Elkhart, Ind.
Garlock-Walker Machinery Co., Toronto, Ont.
Hepburn, John T., Ltd., Toronto, Ont.
McCabe, J. J., New York, N.Y.
Niles-Bement-Pond Co., New York.
H. W. Petrie, Toronto.
Rivett Lathe & Grinder Co., Boston, Mass.
Riverside Machinery Depot, Detroit, Mich.
Whitcomb-Blaisdell Mach. Tool Co., Worcester, Mass.
A. R. Williams Machy. Co., Toronto.
- LATHES, SPINNING**
Bliss, E. W., Co., Brooklyn, N.Y.
McCabe, J. J., New York, N.Y.
- LATHES, TURRET AND HAND**
Acme Machine Tool Co., Cincinnati, Ohio.
John Bertram & Sons Co., Dundas.
Blount, J. G., & Co., Everett, Mass.
Brown & Sharpe Mfg. Co., Providence, R.I.
Can. Fairbanks-Morse Co., Montreal.
Canada Machinery Corp., Galt, Ont.
Corbet Fdry. & Mach. Co., Ltd., Owen Sound, Ont.
Foss & Hill Machy. Co., Montreal.
Foster Machine Co., Elkhart, Ind.
Garlock-Walker Machy. Co., Toronto, Ont.
Hepburn, John T., Ltd., Toronto, Ont.
The Jenckes Mach. Co., Ltd., Sherbrooke, Que.
H. K. LeBlond Mach. Tool Co., Cincinnati, Ohio.
McCabe, J. J., New York, N.Y.
Montreal Machy. & Supplies, Ltd., Montreal, Que.
Mulliner-Enlund Tool Co., Syracuse, N.Y.
National-Acme Co., Cleveland, Ohio.
New Britain Machine Co., New Britain, Conn.
Niles-Bement-Pond Co., New York.
Oliver Machinery Co., Grand Rapids, Mich.
H. W. Petrie, Toronto.
Rivett Lathe & Grinder Co., Boston, Mass.
Riverside Machinery Depot, Detroit, Mich.
Steinle Turret Mach. Co., Madison, Wis.
Warner & Swasey Co., Cleveland, O.
A. R. Williams Machy. Co., Toronto.
- LEATHER STRAPPING**
Graton & Knight Mfg. Co., Worcester, Mass.
- LIFTS, PNEUMATIC**
Whiting Foundry Equipment Co., Harvey, Ill.
- LINK BELTING**
Can. Fairbanks-Morse Co., Montreal.
Jones & Glasco, Montreal, Que.
Morse Chain Co., Ithaca, N.Y.
- LINOLEUM MILL MACHINERY**
Reitmans, Ltd., Edinburgh, Scotland.
- LIQUID AIR**
Carter Welding Co., Toronto, Ont. —
L'Air Liquide Society, Montreal, Toronto.
Prest-O-Lite Co., Inc., Toronto, Ont.
Lynman Tube & Supply Co., Montreal, Que.
- LOCKERS, STEEL WARDROBE AND STEEL MATERIAL**
Canada Wire & Iron Goods Co., Hamilton, Ont.
- LUBRICANTS**
Can. Economic Lubricant Co., Montreal.
Cataract Refining & Mfg. Co., Toronto.
- LUBRICATORS**
Rorer, C. F. & Co., Hopedale, Mass.
Trahern Pump Co., Rockford, Ill.
- MACHINERY DEALERS**
Baird Machy. Co., W. J., Detroit, Mich.
Bath & Co., Cyril J., Cleveland, Ohio.
Can. Fairbanks-Morse Co., Montreal.
Dickow, Fred C., Chicago, Ill.
Dominion Machy. Co., Toronto, Ont.
Garlock-Walker Machinery, Toronto.
Foss & Hill Machy. Co., Montreal.
Montreal Machy. & Supplies, Ltd., Montreal, Que.
H. W. Petrie, Ltd., Montreal.
H. W. Petrie, Toronto.
R. E. T. Pringle, Ltd., Toronto, Ont.
A. R. Williams Machy. Co., Toronto.
- MACHINERY, COILING (WIRE AND SPRING)**
Sleeper & Hartley, Inc., Worcester, Mass.
- MACHINERY, FLEXIBLE COILED CASING**
Sleeper & Hartley, Inc., Worcester, Mass.
- MACHINERY, FLEXIBLE METAL TUBE**
Sleeper & Hartley, Inc., Worcester, Mass.
- MACHINERY, FLEXIBLE SHAFT COILING**
Sleeper & Hartley, Inc., Worcester, Mass.
- MACHINERY GUARDS (SEE GUARDS)**
- MACHINERY REPAIRS**
Prest-O-Lite Co., Inc., Toronto, Ont.
Sumbling Mach. Co., W. H. S., Toronto, Ont.
- MACHINISTS' SCALES, SMALL TOOLS AND SUPPLIES**
Can. Fairbanks-Morse Co., Montreal.
Frank H. Scott, Montreal.
J. H. Williams & Co., Brooklyn, N.Y.

WHITTAKER'S BOOKS

A Complete Catalogue of Engineering Works published by us will be sent post free on application.

JUDGE.—High Speed Internal Combustion Engines.. By A. W. Judge. A.R.C.S., A.M.I.A.E. 360 pages. Medium 8vo. With 208 Illustrations, and 38 Tables. 15s. net (postage 6d.; abroad 1s.).

—The Properties of Aerofoils and Resistance of Aerodynamic Bodies. 300 pp. Medium 8vo. Cloth. With 150 Figures. 15s. net (postage 6d.; abroad 8d.).

DOVER.—Electric Traction: A Treatise on the Application of Electric Power to Electric Traction on Railways and Tramways. By A. T. Dover, A.M.I.E.E., Assoc. Amer. I.E.E., Lecturer in Electric Traction at the Battersea Polytechnique, London. With 518 Illustrations, 33 Tables, 5 Folding Plates. 688+xx pp. Medium 8vo., cloth, 18s. net (postage 7d., abroad 1s.).

DOVER.—Power Wiring Diagrams: A Handbook of Connection Diagrams of Control and Protective Systems for Industrial C.C. and A.C. Machines and Apparatus. With 254 Illustrations. Pocket size (6½" x 4"). F'cap 8vo., cloth, 6s. net (Rounded edges).

PULL.—Modern Milling. A Practical Manual on Milling Machines, Milling Accessories, and Milling Operations, for the use of Engineers, Milling Operators, Practical Mechanics and Engineering Students. By Ernest Pull, A.M.I. Mech.E., M.I.Mar.E. With 188 Illustrations and many Tables. Demy 8vo., cloth, 7s. 6d. net (postage, 5d.; abroad 6d.).

MAYCOCK.—Electric Wiring, Fittings, Switches and Lamps (Circuits). A Practical Book for Electric Light Engineers and Contractors, Consulting Engineers, Architects, Builders, Wiremen, and Students. Fifth Edition, Revised. With 620 Illustrations. Crown 8vo. 7s. d. net (postage 6d.; abroad 10d.).

WHITTAKER & COMPANY

2, White Hart Street, Paternoster Square
LONDON, E.C. 4, ENGLAND

A Good, Hard and Fast Worker

*Superior
Distinctive
Design*

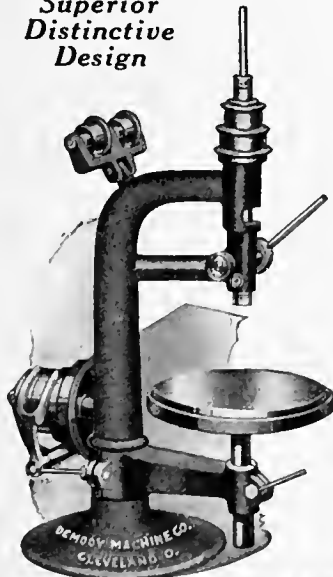

The DE MOOY IMPROVED SENSITIVE DRILLS

are built in two sizes; No. 1 has capacity from 0 to 5-16"; No. 2 from 0 to ½"; No. 2 is built in two types, either as Bench or Floor drill.

The machines are built sturdy; compact; convenient; economical and dependable for small accurate drilling.

Write for specifications.

The De Mooy Machine Co.
CLEVELAND, OHIO

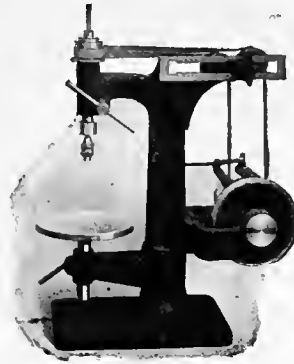

From the
SMALLEST
to the
LARGEST
in Ball Bearing
Sensitive Drilling
Machines

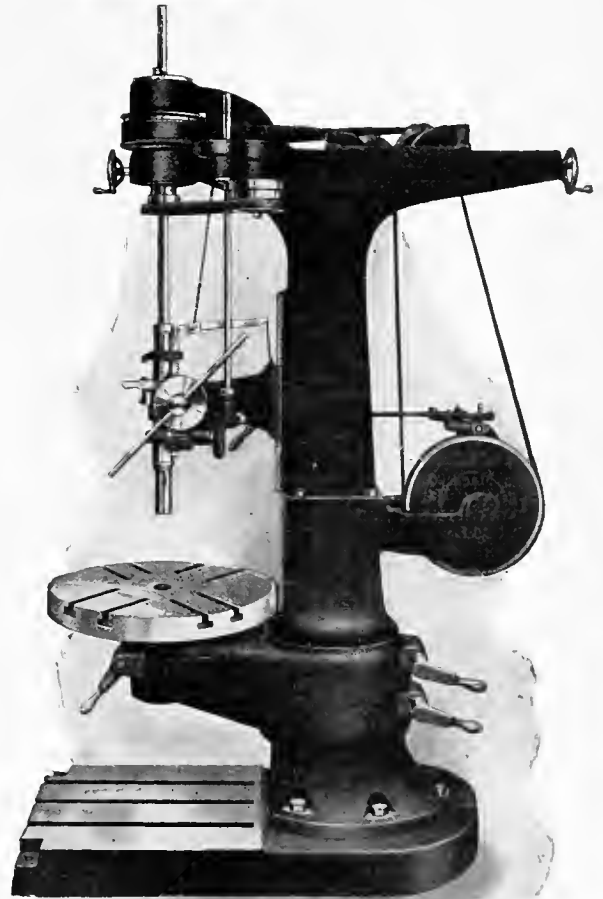

WHATEVER YOUR REQUIREMENTS as to size, if you want to get the machine most suitable to your work, get the

Avel

The widest line in sizes,—the greatest variety in styles,—higher speeds, together with extreme simplicity and convenience, enable you to specialize to best advantage.

GOOD DELIVERIES

WRITE US AT ONCE

THE CINCINNATI PULLEY MACHINERY CO.
CINCINNATI, OHIO, U.S.A.

If any advertisement interests you, tear it out now and place with letters to be answered.

MANDRELS

Can. Fairbanks-Morse Co., Montreal.
Cleveland Twist Drill Co., Cleveland.
Hannifin Mfg. Co., Chicago, Ill.
A. B. Jardine & Co., Hespeler, Ont.
Manufacturers Equip. Co., Chicago, Ill.
Monarch Brass Mfg. Co., Toronto, Ont.
Morse Twist Drill & Mach. Co., New Bedford, Mass.
H. W. Petrie, Ltd., Montreal.
H. W. Petrie, Toronto.
Pratt & Whitney Co., Dundas, Ont.
Stone Tool & Supply Co., J. R., Detroit, Mich.
Western Tool & Mfg. Co., Springfield, Ohio.

MARKING DEVICES

Hogson & Pettis Mfg. Co., New Haven, Conn.
Pritchard-Andrews Co. of Canada, Ottawa, Ont.
Matthews, Jas. H., & Co., Pittsburg, Pa.

MARKING MACHINERY

Brown, Boggs Co., Hamilton, Ont.
Foss & Hill Machy. Co., Montreal.
Martin Machine Co., Greenfield, Mass.
Noble & Westbrook Mfg. Co., Hartford, Conn.
Perrin, Wm. R., Toronto.

MEASURING TAPES AND RULES

James Chesterman & Co., Ltd., Sheffield, Eng.
METALLURGISTS
Can. Inspection & Testing Lab., Montreal, Que.
Toronto Testing Laboratory, Ltd., Toronto.

METALS

Can. B. K. Morton, Toronto, Montreal.
Dom. Iron & Wrecking Co., Ltd., Montreal, Que.
Montreal Machy. & Supplies, Ltd., Montreal, Ont.
Samuel, Benjamin & Co., M. & L., Toronto, Ont.

MILL MACHINERY

Alexander Fleck, Ltd., Ottawa.

MILLING MACHINES, AUTOMATIC

Adams, O. R., 159 St. Paul St. Rochester, N.Y.
Bilton Mach. Tool Co., Bridgeport, Conn.

MILLING ATTACHMENTS

John Bertram & Sons Co., Dundas.
Brown & Sharpe Mfg. Co., Providence.
Canada Machinery Corp., Galt, Ont.
Cincinnati Milling Machine Co., Cincinnati.
Cleveland Milling Mach. Co., Cleveland, Ohio.
Ford-Smith Mach. Co., Hamilton, Ont.
Fox Machine Co., Jackson, Mich.
Hendey Mach. Co., Torrington, Conn.
KempSmith Mfg. Co., Milwaukee, Wis.
Huckley Machine Works, Hockley, Ill.
Niles-Bement-Pond Co., New York.
H. W. Petrie, Ltd., Montreal.
Pratt & Whitney Co., Dundas, Ont.

MILLING MACHINES, HAND

United States Mach. Tool Co., Cincinnati, Ohio.
Whitney Mfg. Co., Hartford, Conn.

MILLING MACHINES, HORIZONTAL AND VERTICAL

Brown & Sharpe Mfg. Co., Providence.
John Bertram & Sons Co., Dundas.
Cleveland Milling Machine Co., Cleveland, Ohio.
Garlock-Walker Machinery Co., Toronto, Ont.
Canada Machinery Corp., Galt, Ont.
Ford-Smith Mach. Co., Hamilton, Ont.
Foss & Hill Machy. Co., Montreal.
Fox Machine Co., Jackson, Mich.
Gooley & Edlund, Cortland, N.Y.
KempSmith Mfg. Co., Milwaukee, Wis.
R. K. LeBlond Mach. Tool Co., Cincinnati, Ohio.
Niles-Bement-Pond Co., New York.
H. W. Petrie, Ltd., Montreal.
H. W. Petrie, Toronto.
Pratt & Whitney Co., Dundas, Ont.
Riverside Machinery Depot, Detroit, Mich.
Stephens, The John Co., Cincinnati, Ohio.
United States Mach. Tool Co., Cincinnati, Ohio.
Whitney Mfg. Co., Hartford, Conn.
A. R. Williams Machy. Co., Toronto.

MILLING MACHINES, PLAIN, BENCH AND UNIVERSAL

Bilton Mach. Tool Co., Bridgeport, Conn.
Brown & Sharpe Mfg. Co., Providence.
Canada Machinery Corp., Galt, Ont.
Cincinnati Milling Machine Co., Cincinnati.
Foss & Hill Machy. Co., Montreal.
Fox Machine Co., Jackson, Mich.
Garlock-Walker Machinery Co., Toronto, Ont.
Garrin Machine Co., New York.
Gooley & Edlund, Cortland, N.Y.
Harding Bros., Chicago, Ill.
Hendey Machine Co., Torrington, Conn.
KempSmith Mfg. Co., Milwaukee, Wis.
LeBlond Mach. Tool Co., R. K., Cincinnati.
Niles-Bement-Pond Co., New York.
H. W. Petrie, Toronto.
Pratt & Whitney Co., Dundas, Ont.
Stephens, The John Co., Cincinnati, Ohio.
A. R. Williams Machy. Co., Toronto.

MILLING MACHINES, PROFILE

Brown & Sharpe Mfg. Co., Providence.
Can. Fairbanks-Morse Co., Montreal.
Cook, Asa S., Co., Hartford, Conn.
Foss & Hill Machy. Co., Montreal.
Garlock-Walker Machinery Co., Toronto, Ont.
Garrin Machine Co., New York.
H. W. Petrie, Toronto.
Pratt & Whitney Co., Dundas, Ont.
Riverside Machinery Depot, Detroit, Mich.

MILLING TOOLS

Aikenhead Hardware Co., Toronto, Ont.
Brown & Sharpe Mfg. Co., Providence.
Ford-Smith Mach. Co., Hamilton, Ont.
Geometric Tool Co., New Haven, Conn.
KempSmith Mfg. Co., Milwaukee, Wis.
Tabor Mfg. Co., Philadelphia, Pa.

MINE CARS

Can. Fairbanks-Morse Co., Montreal.
Cumming & Son, J. W., New Glasgow, Canada.
Jenckes Mach. Co., Sherbrooke, Que.

MacKinnon, Holmes Co., Sherbrooke.

Mirch & Heathorn, Belleville, Ont.
Modern Tool Co., Erie, Pa.
Pratt & Whitney Co., Dundas, Ont.
Sheldons, Ltd., Galt, Ont.

MINING MACHINERY

Can. Fairbanks-Morse Co., Montreal.
Cleveland Pneumatic Tool Co. of Canada, Toronto.
Jenckes Mach. Co., Sherbrooke, Que.
H. W. Petrie, Ltd., Montreal.
H. W. Petrie, Toronto.
A. R. Williams Machy. Co., Toronto.

MORTISING MACHINES

Canada Machinery Corp., Galt, Ont.
Garlock-Walker Machinery Co., Toronto, Ont.
New Britain Mach. Co., New Britain, Conn.

MOTORS, ELECTRIC

Can. Fairbanks-Morse Co., Montreal.
Dominion Machinery Co., Toronto.
Garlock-Walker Machinery Co., Toronto, Ont.
Lancashire Dynamo & Motor Co., Ltd., Toronto.
H. W. Petrie, Ltd., Montreal.
R. E. T. Pringle, Ltd., Toronto, Ont.
Wickes Brothers, Saginaw, Mich.
A. R. Williams Machy. Co., Toronto.

MOTORS, PNEUMATIC

Cleveland Pneumatic Tool Co. of Canada, Toronto.
Garlock-Walker Machinery Co., Toronto, Ont.

MULTIPLE INDEX CENTRES

Garrin Machine Co., New York.

NAILS, COPPER AND YELLOW METAL

Hungerford Brass & Copper Co., New York, N.Y.

NAME PLATES, BRONZE, ETCHED AND STAMPED

Matthews, Jas. H. & Co., Pittsburg, Pa.
Pritchard-Andrews Co., Ottawa, Can.

NIPPLE HOLDERS

Curtis & Curtis Co., Bridgeport, Conn.

NOBLE THREADING MACHINES

John H. Hall & Sons, Ltd., Brantford, Ont.
Lanthe Machine Co., Waynesboro, Pa.

NITROGEN

Carter Welding Co., Toronto, Ont.
L'Air Liquide Society, Montreal, Toronto.

NUTS, SEMI-FINISH AND FINISHED

Can. B. K. Morton, Toronto, Montreal.
Galt Machine Screw Co., Galt, Ont.
National-Acme Co., Cleveland, Ohio.

NUT BURRING MACHINES

National Machy. Co., Tiffin, O.
Petrie of Montreal, Ltd., H. W., Montreal, Que.

NUT MACHINES (HOT)

National Machy. Co., Tiffin, O.
Petrie of Montreal, Ltd., H. W., Montreal, Que.

NUT FACING AND BOLT**SHAVING MACHINES**

Garrin Machine Co., New York.
National Machy. Co., Tiffin, O.
Petrie of Montreal, Ltd., H. W., Montreal, Que.
Victor Tool Co., Waynesboro, Pa.

NUT TAPPERS

John Bertram & Sons Co., Dundas.
Canada Machinery Corp., Galt, Ont.
Garrin Machine Co., New York.
Greenfield Tap & Die Corp., Greenfield, Mass.
Hall, J. H., & Son, Brantford, Ont.
A. B. Jardine & Co., Hespeler.
Lanthe Machine Co., Waynesboro, Pa.
National Machy. Co., Tiffin, O.
Petrie of Montreal, Ltd., H. W., Montreal, Que.

OIL GROOVING MACHINES

National Mach. Tool Co., Cincinnati, O.

OIL SEPARATORS

Can. Fairbanks-Morse Co., Montreal.
Sheldons, Ltd., Galt, Ont.
Smart-Turner Machine Co., The, Hamilton.

OLT STONES

Aikenhead Hardware Co., Toronto, Ont.
Carborundum Co., Niagara Falls, N.Y.
Norton Co., Worcester, Mass.

OSCILLATING VALVE GRINDERS (PNEUMATIC)

Cleveland Pneumatic Tool Co. of Canada, Toronto.

OVENS FOR BAKING, BLUING, DRYING, ENAMELING, JAPANING AND LACQUERING

Brantford Oven & Rack Co., Brantford, Ont.
Oven Equipment & Mfg. Co., New Haven, Conn.
Whiting Foundry Equipment Co., Harvey, Ill.

OVEN TRUCKS, STEEL

Brantford Oven & Rack Co., Brantford, Ont.
MacKinnon, Holmes & Co., Sherbrooke, Que.
Oven Equipment & Mfg. Co., New Haven, Conn.
Whiting Foundry Equipment Co., Harvey, Ill.

OVENS FOR DRYING, TEMPER AND UNDER TRUCKS

Brantford Oven & Rack Co., Brantford, Ont.
Oven Equipment & Mfg. Co., New Haven, Conn.

OXY-ACETYLENE WELDING AND CUTTING

Can. Welding Works, Montreal, Que.
Carter Welding Co., Toronto.
Prest-O-Lite Co., Inc., Toronto, Ont.
Toronto Welding Co., Toronto, Ont.

OXY-ACETYLENE WELDING AND CUTTING PLANTS

Carter Welding Co., Toronto.
L'Air Liquide Society, Montreal, Toronto.
Prest-O-Lite Co., Inc., Toronto, Ont.

OXYGEN (SEE ACETYLENE)

PACKINGS, ASBESTOS
Bennett, W. P., 51 Montford St., Montreal, Que.
Cleveland Wire Spring Co., Cleveland.
New Britain Mach. Co., New Britain, Conn.

PACKINGS, LEATHER, HYDRAULIC, ETC.
Grafton & Knight Mfg. Co., Worcester, Mass.
William R. Perrin, Ltd., Toronto.
H. W. Petrie, Toronto.

PACKING, RUBBER

Denlop Tire & Rubber Goods Co., Ltd., Toronto, Ont.

PAPER MILL MACHINERY

Bertrams, Ltd., Edinburgh, Scotland.
MacKinnon, Holmes & Co., Sherbrooke, Que.

PATTERN SHOP EQUIPMENT

Canada Machinery Corp., Galt, Ont.
Fox Machine Co., Jackson, Mich.
Garlock-Walker Machinery Corp., Toronto, Ont.
Oliver Machy. Co., Grand Rapids, Mich.

PATENT SOLICITORS

Babeock & Sons, Montreal.
Budden, Hanbury, A., Montreal.
Fetherstonhaugh & Co., Ottawa.
Marion & Marion, Montreal.
Bidout & Meybee, Toronto.

PATTERNS

Winnipeg Gear & Engr. Co., Winnipeg, Man.

PERFORATED METALS AND ORNAMENTAL IRON GOODS

Canada Wire & Iron Goods Co., Hamilton.

PHOTOSTATS

Commercial Camera Co., Providence, R.I.

PIG IRON

Hanna & Co., M. A., Cleveland, O.
Steel Co. of Canada, Ltd., Hamilton, Ont.

PIPE CUTTING AND THREADING MACHINES

Butterfield & Co., Rock Island, Que.
Can. Fairbanks-Morse Co., Montreal.
Curtis & Curtis Co., Bridgeport, Conn.
Dominion Machy. Co., Toronto, Ont.
Foss & Hill Machy. Co., Montreal.
Fox Machine Co., Jackson, Mich.
Garlock-Walker Machinery Co., Toronto, Ont.
Garrin Machine Co., New York.
John H. Hall & Sons, Brantford.
A. B. Jardine & Co., Hespeler, Ont.
Lanthe Machine Co., Waynesboro, Pa.
R. McDougall Co., Galt.
H. W. Petrie, Toronto.
Wells Brothers Co. of Canada, Galt, Ont.
Williams Tool Co., Erie, Pa.
A. R. Williams Machy. Co., Toronto.

PIPE CUTTERS, ROLLING

Curtis & Curtis Co., Bridgeport, Conn.
John H. Hall & Sons, Ltd., Brantford, Ont.
H. W. Petrie, Ltd., Montreal.

PIPE, RIVETED STEEL

The Jenckes Mach. Co., Ltd., Sherbrooke, Que.
Toronto Iron Works, Ltd., Toronto.

PLANNER JACKS

Armstrong Bros. Tool Co., Chicago.

PLANERS, STANDARD AND ROTARY

John Bertram & Sons Co., Dundas.
Canada Machinery Corp., Galt, Ont.
Can. Fairbanks-Morse Co., Montreal.
Dominion Machinery Co., Toronto.
Foss & Hill Machy. Co., Montreal.
Gardner, Robt., & Son, Montreal.
Garlock-Walker Machinery Co., Toronto, Ont.
Garrin Machine Co., New York.
Hamilton Machine Tool Co., Hamilton, Ohio.
Mortco Mfg. Co., Muskegon Heights, Mich.
Niles-Bement-Pond Co., New York.
Oliver Machy. Co., Grand Rapids, Mich.
Petrie of Montreal, Ltd., H. W., Montreal, Que.
H. W. Petrie, Toronto.
Whitecomb-Blaisdell Mach. Tool Co., Worcester, Mass.

PLANING AND SHAPING MACHINERY

Canada Machinery Corp., Galt, Ont.
Can. Fairbanks-Morse Co., Montreal.
Foss & Hill Machy. Co., Montreal.
Garlock-Walker Machinery Co., Toronto, Ont.
Garrin Machine Co., New York.
Hamilton Machine Tool Co., Hamilton, Ohio.
Niles-Bement-Pond Co., New York.
Petrie of Montreal, Ltd., H. W., Montreal, Que.
H. W. Petrie, Toronto.
Preston Woodworking Machy. Co., Preston, Ont.
Riverside Machinery Depot, Detroit, Mich.
Stephens, The John Co., Cincinnati, Ohio.
A. R. Williams Machy. Co., Toronto.

PLANING MILL EXHAUSTERS

Can. Blower & Forge Co., Kitchener, Ont.
Sheldons, Ltd., Galt, Ont.
Niles-Bement-Pond Co., New York.

PLIERS

Aikenhead Hardware Co., Toronto, Ont.
Canadian Billings & Spencer, Ltd., Welland.

PLUG MILLERS

Ranfield, Edwin J., Toronto.

POLISH, METAL

A. S. K. Chemical Co., Elora, Ont.

PRESSES, ARBOR

Atlas Press Co., Kalamazoo, Mich.
Hannifin Mfg. Co., Chicago, Ill.
Metalwood Mfg. Co., Detroit, Mich.

PRESSES, BROACHING, FORGING AND FLANGING

Atlas Press Co., Kalamazoo, Mich.
E. W. Bliss Co., Brooklyn, N.Y.
Metalwood Mfg. Co., Detroit, Mich.
Toledo Machine & Tool Co., Toledo.

PRESSES, CAM, TOGGLE, EYELET

Baird Machine Co., Bridgeport, Conn.
Consolidated Press Co., Hastings, Mich.
Toledo Machine & Tool Co., Toledo, O.

PRESSES FOR SHEETS

Atlas Press Co., Kalamazoo, Mich.
Charles F. Elmes Eng. Works, Chicago.
Dominion Machinery Co., Toronto.
Foss & Hill Machy. Co., Montreal.
Garlock-Walker Machinery Co., Toronto, Ont.
Metalwood Mfg. Co., Detroit, Mich.
William R. Perrin, Ltd., Toronto.
Petrie of Montreal, Ltd., H. W., Montreal, Que.
H. W. Petrie, Toronto.
West Tire Setter Co., Rochester, N.Y.

PRESSES, FILTER

Wm. R. Perrin, Ltd., Toronto.

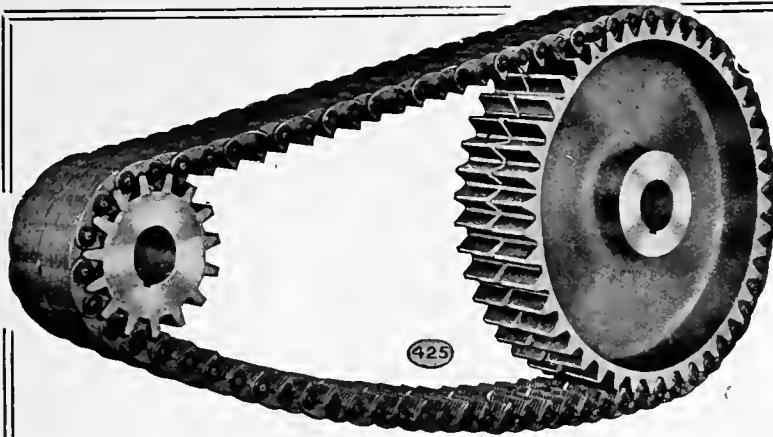

RENOLD CHAINS

The proven efficient form of Power Transmission.

PATENT SILENT

Equally suitable for main shaft or machine drives. Save space and power, increase output and ensure durability.

Chain and Parts Carried in Stock.

Sole Canadian Agents

Jones & Glassco. (Reg'd)

Branch Office: ENGINEERS St. Nicholas Bldg.
TORONTO, ONT. MONTREAL, P.Q.



Adjustoglas
TRADE MARK REGISTERED

Goggles are gladly worn, you don't have to make men wear them.

THE STRONG, KENNARD & NUTT COMPANY
2042 E. 9th Street Cleveland, Ohio

Long Distance is Calling!

Telegrams and Long Distance Telephone Messages are not uncommon among the replies to ads in our Classified Advertising Section.

METAL WORKING MACHINERY

Call on our Rochester stock for 25" Sliding Drill Presses, 10" Shapers, Power Feed Milling Machines, Screw Machines, Engine Lathes, No. 6 Rivett Internal Grinder.

OGDEN R. ADAMS
149 ST. PAUL STREET
ROCHESTER, N.Y.



BOLT, NUT, FORGING AND WIRE NAIL MACHINERY

"National" Bolt Cutters, "Wedge Grip" Bolt and Rivet Headers, Forging Machines, Nut Machines, Roll Threaders and Wire Nail Machines are used by leading Railroads and Industrials.



CANADIAN AGENT:
H. W. PETRIE, Ltd.
TORONTO, ONT.
MONTREAL, QUE.
VANCOUVER, B. C.

Measuring Tapes, Steel Rules, Straight Edges, Surveyors' Band Chains, Engineers' Tools

MANUFACTURED BY

JAMES CHESTERMAN & CO., Limited

SHEFFIELD, ENGLAND

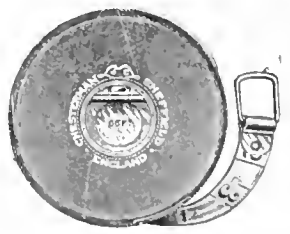

Chesterman tools are the highest standard of accuracy in the British Empire, and the quality of steel and substantial build guarantee a maximum of service and economy.



Steel Depth Gauge

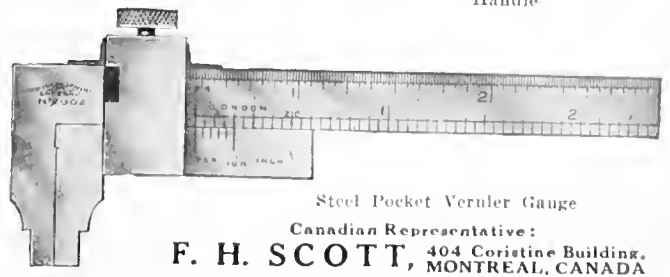

Steel Pocket Vernier Gauge

Wind-up Measures, Steel, Linen and Metallic. With Improved Patent Flush Handle

Canadian Representative:
F. H. SCOTT, 404 Coristine Building, MONTREAL, CANADA

If any advertisement interests you, tear it out now and place with letters to be answered.

PRESSES, DROP AND FORGING

W. H. Banfield & Son, Toronto.
E. W. Bliss Co., Brooklyn, N.Y.
Brown, Boggs Co., Ltd., Hamilton, Canada.
Charles F. Elmes Eng. Works, Chicago, Ill.
Cau. Fairbanks-Morse Co., Montreal.
Erie Foundry Co., Erie, Pa.
Niles-Bement-Pond Co., New York.
Wm. R. Perrin, Ltd., Toronto.
Petrie of Montreal, Ltd., H. W., Montreal, Que.
H. W. Petrie, Toronto.
Toledo Machine & Tool Co., Toledo.

PRESSES, HYDRAULIC

John Bertram & Sons Co., Dundas.
Charles F. Elmes Eng. Works, Chicago, Ill.
Dominion Machy. Co., Toronto, Ont.
Mackintosh, Hemphill & Co., Pittsburgh, Pa.
Metalwood Mfg. Co., Detroit, Mich.
Niles-Bement-Pond Co., New York.
William R. Perrin, Ltd., Toronto.
Petrie of Montreal, Ltd., H. W., Montreal, Que.
H. W. Petrie, Toronto.
Toledo Machine & Tool Co., Toledo.
West Tire Setter Co., Rochester, N.Y.
A. R. Williams Machy. Co., Toronto.

PRESSES, HYDRAULIC DIE STAMPING

Montreal Machy. & Snipples Ltd., Montreal, Que.

PRESSES, PNEUMATIC

Metalwood Mfg. Co., Detroit, Mich.
Toledo Machine & Tool Co., Toledo.

PRESSES, POWER

Baird Machine Co., Bridgeport, Conn.
E. W. Bliss Co., Brooklyn, N.Y.
Brown, Boggs & Co., Hamilton, Can.
Canada Machinery Corp., Galt, Ont.
Can. Fairbanks-Morse Co., Montreal.
Consolidated Press Co., Hastings, Mich.
Charles F. Elmes Eng. Works, Chicago, Ill.
Garlock-Walker Machinery Co., Toronto, Ont.
William R. Perrin, Ltd., Toronto.
Petrie of Montreal, Ltd., H. W., Montreal, Que.
H. W. Petrie, Toronto.
Riverside Machinery Depot, Detroit, Mich.
Toledo Machine & Tool Co., Toledo.
A. R. Williams Machy. Co., Toronto.

PRESSES, BALING

William R. Perrin, Ltd., Toronto.

PRESSES, SPRING FOOT

Brown, Boggs & Co., Hamilton, Can.
Consolidated Press Co., Hastings, Mich.
Taylor & Fern Co., Hartford, Conn.
Toledo Machine & Tool Co., Toledo.

PRESSES, SCREW

Barnes, W. F. & John, Co., Rockford, Ill.
Wm. R. Perrin, Ltd., Toronto.

PRESSES, TRIMMING

Erie Foundry Co., Erie, Pa.
Consolidated Press Co., Hastings, Mich.

PROPELLERS

Kennedy & Sons, Wm., Owen Sound, Ont.
Ontarin Specialties, Ltd., Ottawa, Can.

PULLEYS

American Pulley Co., Philadelphia.
Baird Machine Co., Bridgeport, Conn.
Bernard Industrial Co., Fortierville, Que.
Brown & Sharpe Mfg. Co., Providence, R.I.
Can. Bond Hanger & Cplg. Co., Alexandria, Ont.
Can. Fairbanks-Morse Co., Montreal.
Dominion Machy. Co., Toronto, Ont.
The Jencks Mach. Co., Ltd., Sherbrooke, Que.
Wm. Kennedy & Sons, Ltd., Owen Sound, Ont.
Montreal Machy. & Supplies, Ltd., Montreal, Que.
Petrie of Montreal, Ltd., H. W., Montreal, Que.
H. W. Petrie, Toronto.

Positive Clutch & Pulley Works, Lbs., Toronto.

The Smart-Turner Mach. Co., Hamilton.
A. R. Williams Machy. Co., Toronto.

PULLEYS, FRICTION CLUTCH.

American Pulley Co., Philadelphia, Pa.
Baird Machine Co., Bridgeport, Conn.
Petrie of Montreal, Ltd., H. W., Montreal, Que.
H. W. Petrie, Toronto.

Positive Clutch & Pulley Works, Toronto.**Bernard Industrial Co., A., Fortierville, Que.****PULLEY MACHINERY,**

DRILLING AND TAPPING
Can. Fairbanks-Morse Co., Montreal.
Cincinnati Pulley Mch. Co., Cincinnati, Ohio.
Wells Bros. Co. of Canada, Galt, Ont.

PUMPS, AIR

The Jencks Mach. Co., Ltd., Sherbrooke, Que.
Smart-Turner Mach. Co., Hamilton.

PUMPS, CENTRIFUGAL

Can. Blower & Forge Co., Kitchener, Ont.
Can. Ingersoll-Rand Co., Sherbrooke, Que.
H. W. Petrie, Toronto.
Pratt & Whitney Co., Dundas, Ont.
Sheldons, Ltd., Galt, Ont.
Smart-Turner Machine Co., Hamilton, Ont.

PUMPS, FUEL OIL

Trabem Pump Co., Rockford, Ill.

PUMPS, HIGH PRESSURE

Blake Pump & Condenser Co., Fitchburg, Mass.
Charles F. Elmes Eng. Works, Chicago, Ill.
William R. Perrin, Ltd., Toronto.
Smart-Turner Mach. Co., Hamilton.

PUMPS, ALL KINDS

Blake Pump & Condenser Co., Fitchburg, Mass.
Can. Blower & Forge Co., Kitchener, Ont.
Charles F. Elmes Eng. Works, Chicago, Ill.
William R. Perrin, Ltd., Toronto.
H. W. Petrie, Toronto.
The Smart-Turner Mach. Co., Hamilton.
A. R. Williams Machy. Co., Toronto.

PUMPS, HYDRAULIC

Blake Pump & Condenser Co., Fitchburg, Mass.
Charles F. Elmes Eng. Works, Chicago, Ill.
Metalwood Mfg. Co., Detroit, Mich.
Smart-Turner Mach. Co., Hamilton.
Wm. R. Perrin, Ltd., Toronto.

PUMPS, LUBRICANT AND OIL

Bellevue Industrial Furnace Co., Detroit, Mich.
Cincinnati Lubricant Pump Co., Cincinnati, Ohio.
Roper, C. F. Co., Hopedale, Mass.
Trabem Pump Co., Rockford, Ill.

PUMP LEATHERS

Can. B. K. Morton, Toronto, Montreal.
Graton & Knight Mfg. Co., Worcester, Mass.

PUMPS, ROTARY, POWER DRIVEN

Trabem Pump Co., Rockford, Ill.

PUNCHES AND DIES

W. H. Banfield & Sons, Toronto.
E. W. Bliss Co., Brooklyn, N.Y.
Brown, Boggs Co., Ltd., Hamilton, Canada.
Can. Blower & Forge Co., Kitchener, Ont.
Can. Fairbanks-Morse Co., Montreal.
Gardner, Robt. & Son, Montreal.
A. B. Jardine & Co., Hespeler, Ont.
Mulliner-Enlund Tool Co., Syracuse, N.Y.
Petrie of Montreal, Ltd., H. W., Montreal, Que.
H. W. Petrie, Toronto.
Pratt & Whitney Co., Dundas, Ont.
Toledo Machine & Tool Co., Toledo, O.

PUNCHES, POWER

John Bertram & Sons Co., Dundas.
Bliss, E. W. Co., Brooklyn, N.Y.
Brown, Boggs Co., Ltd., Hamilton, Canada.
Canada Machinery Corp., Galt, Ont.
Consolidated Press Co., Hastings, Mich.
Mackintosh, Hemphill & Co., Pittsburgh, Pa.
Niles-Bement-Pond Co., New York.

PUNCHES, PNEUMATIC

Corbet Fdry. & Mach. Co., Ltd., Owen Sound, Ont.

PUNCHING MACHINES, HORIZONTAL

Bertrams, Ltd., Edinburgh, Scotland.
John Bertram & Sons Co., Dundas.
Canada Machinery Corp., Galt, Ont.
Bliss, E. W. Co., Brooklyn, N.Y.
Brown, Boggs Co., Ltd., Hamilton, Canada.
Niles-Bement-Pond Co., New York.
Wicks Brothers Saginaw, Mich.
W. A. Whitney Mfg. Co., Rockford, Ill.

PURIFYING AND SOFTENING

APPARATUS
Seafie & Sons Co., Wm. B., Pittsburgh, Pa.

PYROMETERS

Bath & Co., Cyril J., Cleveland, Ohio.
Bellevue Industrial Furnace Co., Detroit, Mich.
Cdn. Hoskins, Ltd., Walkerville, Ont.
Cdn. Instrument Co., Pittsburgh, Pa.
Shore Instrument & Mfg. Co., New York City.
Price Electric Co., Cleveland, Ohio.
Taylor Instrument Co., Rochester, N.Y.
Thwing Instrument Co., Philadelphia, Pa.

QUARTERING MACHINES

John Bertram & Sons Co., Dundas.
Niles-Bement-Pond Co., New York.

RAILING, IRON AND BRASS**(SEE GUARDS)****RAIL BENDERS**

Niles-Bement-Pond Co., New York.

RAILROAD TOOLS

Can. Fairbanks-Morse Co., Montreal.
Cumming & Son, J. W., New Glasgow, Canada.
Niles-Bement-Pond Co., New York.

RAILS, STEEL

Cumming & Son, J. W., New Glasgow, Canada.

RAILING, BRASS

Hungerford Brass & Copper Co., New York, N.Y.

RATCHETS

Keystone Mfg. Co., Buffalo, N.Y.

RAW HIDE PINIONS (SEE GEARS)**REAMER FLUTING MACHINES**

Garrin Machine Co., New York.

REAMERS, ADJUSTABLE

Can. Fairbanks-Morse Co., Montreal.
Cleveland Twist Drill Co., Cleveland.
Montreal Machy. & Supplies, Ltd., Montreal, Que.
Morse Twist Drill & Machine Co., New Bedford, Osborn (Canada), Ltd., Sam'l, Montreal, Que.
Pratt & Whitney Co., Dundas, Ont.
Whitman & Barnes Mfg. Co., St. Catharines, Ont.

REAMERS, BRIDGE, EXPANDING**AND HIGH SPEED**

Aikenhead Hardware Co., Toronto, Ont.
Butterfield & Co., Rock Island, Que.
Can. Fairbanks-Morse Co., Montreal.
Cleveland Twist Drill Co., Cleveland.
Illinois Tool Works, Chicago, Ill.
McKenna Brothers, Pittsburgh, Pa.
Osborn (Canada), Ltd., Sam'l, Montreal, Que.
R. E. T. Pringle, Ltd., Toronto, Ont.

REAMERS, PIPE, CYLINDER

Morse Twist Drill & Machine Co., New Bedford.
H. W. Petrie, Toronto.

REAMERS, STEEL TAPER

Pratt & Whitney Co., Dundas, Ont.

AND LOCOMOTIVE

Butterfield & Co., Rock Island, Que.
Can. Fairbanks-Morse Co., Montreal.
Cleveland Twist Drill Co., Cleveland.
Morse Twist Drill & Machine Co., New Bedford.
Pratt & Whitney Co., Dundas, Ont.

REAMERS, SELF-FEEDING

Butterfield & Co., Rock Island, Que.
Can. Fairbanks-Morse Co., Montreal.
Clark Equipment Co., Buchanan, Mich.
Cleveland Twist Drill Co., Cleveland.
Illinois Tool Works, Chicago, Ill.
A. B. Jardine & Co., Hespeler, Ont.
Morse Twist Drill & Machine Co., New Bedford.
H. W. Petrie, Toronto.
Pratt & Whitney Co., Dundas, Ont.

REAMING MACHINES, PNEUMATIC

Cleveland Pneumatic Tool Co. of Canada Toronto.
Garlock-Walker Machinery Co., Toronto, Ont.

RECORDING INSTRUMENTS

Bristol Co., Waterbury, Conn.
Taylor Instrument Co., Rochester, N.Y.

REGULATORS, PRESSURE,

TEMPERATURE
Can. Fairbanks-Morse Co., Montreal.
Taylor Instrument Cos., Rochester, N.Y.

RESPIRATORS

Strong, Kennard & Nutt Co., Cleveland, Ohio.

SAW MACHINES

Bilton Mach. Tool Co., Bridgeport, Conn.
Can. Blower & Forge Co., Kitchener, Ont.
Cook, Asa S., Co., Hartford, Conn.
Grant Mfg. & Mach. Co., Bridgeport, Conn.
National Machinery Co., Tiffin, O.
H. W. Petrie, Ltd., Montreal.

RIVETS, TUBULAR, BIFURCATED

Hungerford Brass & Copper Co., U. T., New York.
Parmenter & Bulloch Co., Gananoque.
Steel Co. of Canada, Ltd., Hamilton, Ont.

RIVETS, IRON, COPPER AND BRASS

Aikenhead Hardware Co., Toronto, Ont.
Hungerford Brass & Copper Co., U. T., New York.
Parmenter & Bulloch Co., Gananoque.
Steel Co. of Canada, Ltd., Hamilton, Ont.

RIVETERS, PNEUMATIC, HYDRAULIC,

HAMMER, COMPRESSION
Can. Fairbanks-Morse Co., Montreal.
Can. Ingersoll-Rand Co., Sherbrooke, Que.
Cleveland Pneumatic Tool Co. of Canada, Toronto.
Garlock-Walker Machy. Co., Ltd., Toronto, Ont.
Independent Pneumatic Tool Co., Chicago, Ill.
Niles-Bement-Pond Co., New York.
H. W. Petrie, Toronto.
R. E. T. Pringle, Ltd., Toronto, Ont.

RIVETING MACHINES, ELASTIC

ROTARY BLOW
Grant Mfg. & Machine Co., Bridgeport, Conn.
High-Speed Hammer Co., Rochester, N.Y.
Hungerford Brass & Copper Co., U. T., New York.
F. B. Shuster Co., New Haven, Conn.

ROLLS, BENDING AND

STRAIGHTENING
John Bertram & Sons Co., Dundas.
Brown, Boggs Co., Ltd., Hamilton, Canada.
Canada Machinery Corp., Galt, Ont.
Niles-Bement-Pond Co., New York.
Toledo Machine & Tool Co., Toledo.
Wicks Brothers, Saginaw, Mich.

ROLLS, CRUSHING

The Jencks Mach. Co., Ltd., Sherbrooke, Que.

RUBBER MILL MACHINERY

Bertrams, Ltd., Edinburgh, Scotland.

RULES

Brown & Sharpe Mfg. Co., Providence.
James Chesterman & Co., Ltd., Sheffield, Eng.
L. S. Starratt Co., Athol, Mass.

SAFETY APPLIANCES

Strong, Kennard & Nutt Co., Cleveland, Ohio.

SAND BLASTS

Curtis Pneumatic Machinery Co., St. Louis, Mo.
The Jencks Mach. Co., Ltd., Sherbrooke, Que.

SANDING MACHINES

Canada Machinery Corp., Galt, Ont.
Oliver Machy. Co., Grand Rapids, Mich.

SAW MILL MACHINERY

Can. Fairbanks-Morse Co., Montreal.
Canada Machinery Corp., Galt, Ont.
Dominion Machy. Co., Toronto, Ont.
Gardner, Robt. & Son, Montreal.
Curtis Pneumatic Machy. Co., St. Louis, Mo.
H. W. Petrie, Ltd., Montreal.
H. W. Petrie, Toronto.
Preston Woodworking Machy. Co., Preston, Ont.
Wicks Brothers, Saginaw, Mich.
A. R. Williams Machy. Co., Toronto.

SAWS, CIRCULAR METAL

Espen-Lucas Mach. Works, Philadelphia, Pa.
Hunter Saw & Machine Co., Pittsburg, Pa.
Napier Saw Works, Springfield, Mass.
Tabor Mfg. Co., Philadelphia, Pa.

SAWS, HACK (SEE HACK SAWS)

SAWS, INSERTED TOOTH
Espen-Lucas Mach. Works, Philadelphia, Pa.
Hunter Saw & Mach. Co., Pittsburg, Pa.
Napier Saw Works, Springfield, Mass.
Tabor Mfg. Co., Philadelphia, Pa.

SAW MACHINES

Napier Saw Works, Springfield, Mass.
SAWS, BAND AND COPING
Napier Saw Works, Springfield, Mass.

SCLEROSCOPES

Shore Instrument & Mfg. Co., New York City.

SCREW MACHINE PARTS

Johnson Mach. Co., Carlyle, Manchester, Conn.

SCREW MACHINE PRODUCTS

Galt Machine Screw Co., Galt, Ont.
Eastern Mach. Screw Corp., New Haven, Conn.

SCREW MACHINES, HAND, AUTOMATIC

Adams, O. R., 159 St. Paul St., Rochester, N.Y.
Brown & Sharpe Mfg. Co., Providence, R.I.
Can. Fairbanks-Morse Co., Montreal.
Foster Machine Co., Elkhart, Ind.
Garlock-Walker Machy. Co., Ltd., Toronto, Ont.
Garrin Machine Co., New York.
A. B. Jardine & Co., Hespeler.
New Britain Machine Co., New Britain, Conn.
Petrie of Montreal, Ltd., H. W., Montreal, Que.
H. W. Petrie, Toronto.

SCREW MACHINES, MULTIPLE SPINDLE

New Britain Machine Co., New Britain, Conn.
Riverside Machinery Depot, Detroit, Mich.

SCREWS

Can. B. K. Morton, Toronto, Montreal.
Galt Machine Screw Co., Galt, Ont.
National-Acme Co., Cleveland, Ohio.
Steel Co. of Canada, Ltd., Hamilton, Ont.

SCREW PLATES

Butterfield & Co., Rock Island, Que.
A. B. Jardine & Co., Hespeler.
Morse Twist Drill & Machine Co., New Bedford.
Wells Bros. Co. of Canada, Galt, Ont.



For Rapid and Accurate Cutting of Small Gears

such as those used in typewriters, meters, adding machines, magnetos, speedometers, etc., use

The New Hercules Gear Hobber

Construction throughout is heavy and all parts are well supported to prevent vibration and assure long service. The drive is simple, powerful and smooth; all movements are gear operated and no chains are used in transmission.

Spur, worm, or spiral gears up to 8-inch diameter and 8-inch face can be handled at maximum speed—steel gears up to 10 pitch, cast iron gears up to 8 pitch—on the No. 1 machine.

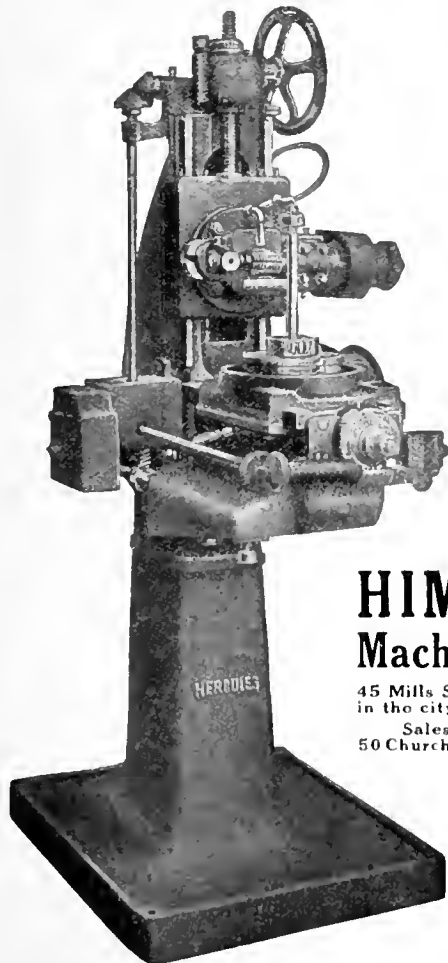

HIMOFF Machine Co.

45 Mills Street, Astoria in the city of New York
Sales Offices:
50 Church St., New York

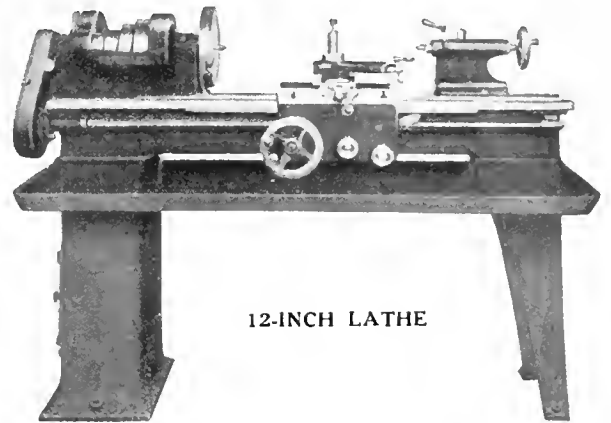

12-INCH LATHE

HERCULES LATHES

It isn't what you do—it's how you do it. Any lathe may do your work, but how will it do it? That is the basis of the Himoff Lathes. They have "Herculean" strength and are strictly modern in design. Rigidity and accuracy guaranteed. Detailed specifications on request.

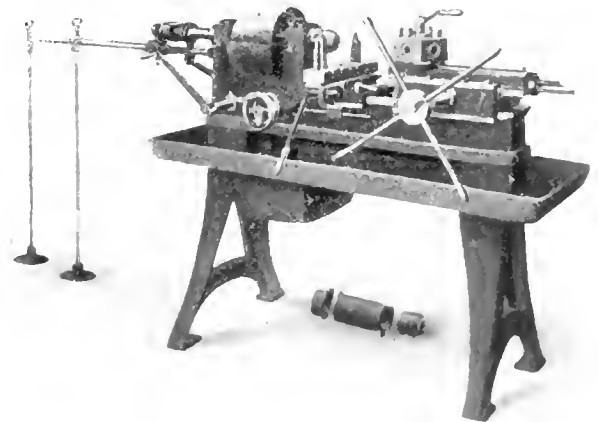

Hercules Screw Machines

are built with $\frac{3}{4}$ -inch, 1-inch and 1 $\frac{1}{2}$ -inch chuck capacities. They are rugged, powerful, handy machines; capable of continuous high production over a wide range of work.

Himoff Machine Company

45 Mills Street
Astoria, City of New York, N.Y.

If any advertisement interests you, tear it out now and place with letters to be answered.

SHANKS, STRAIGHT AND TAPER

Jacobs Mfg. Co., Hartford, Conn.

SHAPERS

John Bertram & Sons Co., Dundas.
 Can. Fairbanks-Morse Co., Montreal.
 Canada Machinery Corp., Galt, Ont.
 Foss & Hill Machy. Co., Montreal.
 Gardner, Robt., & Son, Montreal.
 Hendley Machine Co., Torrington, Conn.
 Hamilton Mach. Tool Co., Hamilton, Ohio.
 Petrie of Montreal, Ltd., H. W., Montreal, Que.
 H. W. Petrie, Toronto.
 Preston Woodworking Mach. Co., Preston, Ont.
 Rhodes Mfg. Co., Hartford, Conn.
 Smith & Mills, Cincinnati, Ohio.
 Steptoe Co., John, Cincinnati, Ohio.

SHAFTING

Can. Bond Hanger & Coupling Co., Alexandria, Ont.
 Can. Fairbanks-Morse Co., Montreal.
 Can. Drawn Steel Co., Hamilton, Ont.
 Garlock-Walker Machy. Co., Ltd., Toronto, Ont.
 The Jenckes Mach. Co., Ltd., Sherbrooke, Que.
 Niles-Bement-Pond Co., New York.
 H. W. Petrie, Toronto.
 Pratt & Whitney Co., Dundas, Ont.
 Strelinger Co., Chas. A., Detroit, Mich.
 A. R. Williams Machy. Co., Toronto.

SHARPENING STONES

Carborundum Co., Niagara Falls, N.Y.
 Norton Co., Worcester, Mass.

SHAVINGS, SEPARATORS

Can. Blower & Forge Co., Kitchener, Ont.
 Sheldons, Ltd., Galt, Ont.

SHEARING MACHINES, ANGLE IRON.**BAR AND GATE**

John Bertram & Sons Co., Dundas.
 Bertrams, Ltd., Edinburgh, Scotland.
 Canada Machinery Corp., Galt, Ont.
 A. R. Jardine & Co., Hespeler.
 Montgomery, Smith & Co., Keynham, Somerset, Eng.

Niles-Bement-Pond Co., New York.
 Toledo Machine & Tool Co., Toledo.
 Wickes Brothers, Saginaw, Mich.

SHEARS, POWER

John Bertram & Sons Co., Dundas.
 Bliss, E. W., Co., Brooklyn, N.Y.
 Brown, Boggs Co., Ltd., Hamilton, Canada.
 Can. Blower & Forge Co., Kitchener, Ont.
 Canada Machinery Corp., Galt, Ont.
 Mackintosh, Humphill & Co., Pittsburgh, Pa.
 National Machy. Co., Tiffin, Ohio.
 Niles-Bement-Pond Co., New York.
 H. W. Petrie, Ltd., Montreal.
 H. W. Petrie, Toronto.
 Toledo Machine & Tool Co., Toledo.

SHEARS, PNEUMATIC

Toledo Machine & Tool Co., Toledo, Ohio.

SHEARS, SQUARING

Brown, Boggs & Co., Hamilton, Canada.

SHEET METAL, GALVANIZED

Samuel, Benjamin & Co., M. & L., Toronto, Ont.

SHEET METAL WORKING TOOLS

Baird Machine Co., Bridgeport, Conn.
 Bliss, E. W., Co., Brooklyn, N.Y.
 Brown, Boggs & Co., Hamilton, Can.
 Peck, Stow & Wilcox, Cleveland, O.
 Steel Bending Brake Works, Ltd., Chatham, Ont.

SHEET METAL STAMPINGS

Dominion Forge & Stpg. Co., Walkerville, Ont.

SHELL BANDING MACHINES,**HYDRAULIC**

Chapman Double Ball-Bearing Co., Toronto, Ont.
 Garlock-Walker Machy. Co., Ltd., Toronto, Ont.
 The Jenckes Mach. Co., Ltd., Sherbrooke, Que.
 Metalwood Mfg. Co., Detroit, Mich.
 Perrin, Ltd., W. R., Toronto, Ont.
 West Tire Setter Co., Rochester, N.Y.

SHELL PAINTING MACHINE

Can. Blower & Forge Co., Kitchener, Ont.
 Sheldons, Ltd., Galt, Ont.

SHELL RIVETERS

Grant Mfg. & Machine Co., Bridgeport, Conn.
 High Speed Hammer Co., Rochester, N.Y.

SHELL WASHER

Can. Economic Lubricant Co., Montreal, Que.

SHRAPNEL SHELL MARKER

Brown-Boggs Co., Hamilton, Ont.
 Noble & Westbrook Mfg. Co., Hartford, Conn.

SIDE TOOLS

Armstrong Bros. Tool Co., Chicago.
 Baxter & Co., Ltd., J. R., Montreal, Que.
 Can. B. K. Morton, Toronto, Montreal.

SIGNS, ENAMEL

Strong, Kennard & Nutt Co., Cleveland, Ohio.

SILVER SOLDER

Hungerford Brass & Copper Co., U. T., New York.
 Geo. H. Lees & Co., Hamilton, Ont.

SKATE SHARPENERS

Raukey Brothers, Stouffville, Ont.
 Can. Bond Hanger & Cplg. Co., Alexandria, Ont.

SLEDGES

Aikenhead Hardware Co., Toronto, Ont.
 Whitman & Barnes Mfg. Co., St. Catharines, Ont.

SLOTTERS

Garrin Machine Co., New York.
 National Acme Co., Cleveland, Ohio.
 Niles-Bement-Pond Co., New York.
 Rhodes Mfg. Co., Hartford, Conn.

SMOKESTACKS.

Corbet Fdry. & Mach. Co., Ltd., Owen Sound, Ont.
 The Jenckes Mach. Co., Ltd., Sherbrooke, Que.
 MacKinnon, Holmes Co., Sherbrooke, Que.

SOCKETS

Brown & Sharpe Mfg. Co., Providence.
 Cleveland Twist Drill Co., Cleveland.

Keystone Mfg. Co., Buffalo, N.Y.
 Modern Tool Co., Erie, Pa.
 Morse Twist Drill & Machine Co., New Bedford.
 J. H. Williams & Co., Brooklyn, N.Y.

SOLDERING IRONS

Aikenhead Hardware Co., Toronto, Ont.
 Prest-O-Lite Co., Inc., Toronto, Ont.
 Brown, Boggs & Co., Hamilton, Can.

SOLDERS

Aikenhead Hardware Co., Toronto, Ont.
 Hungerford Brass & Copper Co., U. T., New York.
 Tallman Brass & Metal Co., Hamilton.

SPELTER

Samuel, Benjamin & Co., M. & L., Toronto, Ont.

SPIKE MACHINES

The Smart-Turner Machine Co., Hamilton.

SPECIAL MACHINERY

Baird Machine Co., Bridgeport, Conn.
 Banfield, Edwin J., Toronto.
 Banfield, W. H., & Sons, Toronto.
 Bertram, John, & Sons Co., Dundas.
 Bliss, E. W., Co., Brooklyn, N.Y.
 Brown, Boggs & Co., Hamilton, Can.
 Can. Fairbanks-Morse Co., Montreal.
 Charles F. Elmes Eng. Works, Chicago.
 Garlock-Walker Machy. Co., Ltd., Toronto, Ont.
 Garrin Machine Co., New York.
 Gooley & Edlund, Inc., Courtland, N.Y.
 Corbet Fdry. & Mach. Co., Ltd., Owen Sound, Ont.
 Grant Mfg. & Machy. Co., Bridgeport, Conn.
 John H. Hall & Sons, Brantford.
 Gray Mfg. & Mach. Co., Toronto, Ont.
 Hidoff Machine Co., New York, N.Y.
 Hyde Engineering Works, Montreal, Que.
 Jardine, A. B., & Co., Hespeler.
 The Jenckes Mach. Co., Ltd., Sherbrooke, Que.
 McClean & Son, F. W., Niagara Falls, Ont.
 National-Acme Co., Cleveland, Ohio.
 D. McKenzie Machinery Co., Guelph, Ont.
 Mulliner & Enlund Tool Co., Syracuse, N.Y.
 Prest-O-Lite Co., Inc., Toronto, Ont.
 Rhodes Mfg. Co., Hartford, Conn.
 Riverside Machinery Depot, Detroit, Mich.
 Smart-Turner Machine Co., Hamilton, Ont.
 T. C. M. Mfg. Co., Harrison, N.J.
 Victoria Foundry Co., Ottawa, Ont.
 Wehber Bros. Mach. Co., Toronto, Ont.
 William R. Perrin, Ltd., Toronto.
 Winnipeg Gear & Engr. Co., Winnipeg, Man.

SPRINGS, MACHINERY

Barnes, Wallace, Co., Bristol, Conn.
 Can. Steel Foundries, Ltd., Montreal, Que.
 Cleveland Wire Spring Co., Cleveland.
 Jas. Steele, Ltd., Guelph, Ont.

SPRING COILING AND WINDING**MACHINERY**

Baird Machine Co., Bridgeport, Conn.
 Garrin Machine Co., New York.
 Sleeper & Hartley, Inc., Worcester, Mass.

SPRING MAKING MACHINERY**(AUTOMATIC)**

Baird Machine Co., Bridgeport, Conn.
 Sleeper & Hartley, Inc., Worcester, Mass.

SPIRAL CONVEYORS

Can. Matthews Gravity Carrier Co., Toronto, Ont.

SPROCKETS, CHAIN

Grant Gear Works, Boston, Mass.
 Morse Chain Co., Ithaca, N.Y.
 Philadelphia Gear Works, Philadelphia, Pa.

SCREW SLOTTERS

Cook, Asa S., Co., Hartford, Conn.
 Garrin Machine Co., New York.
 Pratt & Whitney Co., Dundas, Ont.

SECOND-HAND MACHINERY

Bath & Co., Cyril J., Cleveland, Ohio.
 Davis Machine Tool Co., W. P., New York.
 Dominion Machinery Co., Toronto.
 Inter-Continental Machy. Corp., New York.
 Foss & Hill Machy. Co., Montreal.
 McCabe, J. J., New York, N.Y.
 New York Machinery Exchange, New York.
 H. W. Petrie, Toronto.
 Riverside Machy. Depot, Detroit, Mich.
 Strelinger Co., Chas. A., Detroit, Mich.
 Stoeker-Rumely-Wachs, Chicago, Ill.

SET SCREWS, SAFETY

Aikenhead Hardware Co., Toronto, Ont.
 Allen Mfg. Co., Hartford, Conn.

SOLDER

Jobborn, Geo. A., Hamilton, Ont.

SPROCKET WHEELS, CAST

Perrin, Wm. R., Toronto.

STAIRS, IRON

Canada Wire & Iron Goods Co., Hamilton, Ont.
 Dennis Wire & Iron Works, London, Canada.

STAMPINGS

Pillon Mfg. Co., Oshawa, Ont.
 Dom. Forge & Stpg. Co., Walkerville, Ont.
 Homer & Wilson, Hamilton, Ont.

STAMPING MACHINERY

Brown, Boggs & Co., Hamilton, Can.
 Canada Machinery Corp., Galt, Ont.
 Noble & Westbrook Mfg. Co., Hartford, Conn.
 Matthews, Jas. H. & Co., Pittsburgh, Pa.
 Noble & Westbrook Mfg. Co., Hartford, Conn.
 Pannier Bros. Stamp Co., Pittsburgh, Pa.
 Pritchard-Andrews Co., Ottawa, Can.

STAPLE MACHINES

Sleeper & Hartley, Inc., Worcester, Mass.

STEAM SEPARATORS AND TRAPS

Can. Fairbanks-Morse Co., Montreal.
 Can. Morehead Mfg. Co., Woodstock, Ont.
 H. W. Petrie, Toronto.
 Sheldons, Ltd., Galt, Ont.

The Smart-Turner Machine Co., Hamilton.

STEEL ALLOY (SEE ALLOY STEEL)**STEEL BENDING BRAKES**

Steel Bending Brake Works, Ltd., Chatham, Ont.

STEEL FOR AXES, PLOWS, SAWS,**DRILLS, ETC.**

Colonial Steel Co., Pittsburgh, Pa.
STEEL, CARBON, FERRO-TUNGSTEN
 Can. B. K. Morton, Toronto, Montreal.
 Colonial Steel Co., Pittsburgh, Pa.
 Comstedt, Josef F. A., 120 Broadway, N.Y.
 Latrobe Electric Steel Co., Latrobe, Pa.
 Michigan Steel Exchange, Inc., Detroit, Mich.
 Osborn (Canada), Ltd., Sam'l, Montreal, Que.
 Firth & Sons, Thos., Montreal, Que.
 Vanadium-Alloy Steel Co., Pittsburgh, Pa.
 Vulcan Crucible Steel Co., Aliquippa, Pa.
 Zenith Coal & Steel Products, Montreal, Que.

STEEL, COLD ROLLED

Can. Drawn Steel Co., Hamilton, Ont.

STEEL DIES

Pannier Bros. Stamp Co., Pittsburgh, Pa.

STEEL DRUMS

Smart-Turner Machine Co., Hamilton, Ont.

STEEL PRESSURE BLOWERS

Can. Blower & Forge Co., Kitchener, Ont.

Can. Fairbanks-Morse Co., Montreal.
 Sheldons, Ltd., Galt, Ont.

STEEL, HIGH SPEED

Armstrong Whitworth of Canada, Ltd., Montreal.
 Can. Fairbanks-Morse Co., Montreal.
 Can. B. K. Morton, Toronto, Montreal.
 Colonial Steel Co., Pittsburgh, Pa.
 Comstedt, Josef F. A., 120 Broadway, N.Y.
 H. A. Drury Co., Ltd., Montreal.
 Firth & Sons, Thos., Montreal, Que.
 Hawkridge Bros. Co., Boston, Mass.
 Latrobe Electric Steel Co., Latrobe, Pa.
 Marshall, Geo. A., 70 Lombard, Toronto.
 Michigan Steel Exchange, Inc., Detroit, Mich.
 Osborn (Canada), Ltd., Sam'l, Montreal, Que.
 H. W. Petrie, Toronto.
 Standard Alloys Company, Pittsburgh, Pa.
 Vanadium Alloys Steel Co., Pittsburgh, Pa.
 Vulcan Crucible Steel Co., Aliquippa, Pa.: represented in Canada by Norton, Callard & Co., Montreal, Que.
 Zenith Coal & Steel Products, Montreal, Que.

STEEL VANADIUM

Comstedt, Josef F. A., 120 Broadway, N.Y.
 Drury, H. A., Co., Montreal, Que.
 Michigan Steel Exchange, Inc., Detroit, Mich.
 Vanadium Alloys Co., Pittsburgh, Pa.
 Vulcan Crucible Steel Co., Aliquippa, Pa.

STELLITE, HIGH-SPEED TOOL METAL

Can. B. K. Morton Co., Montreal, Que.
 Deloro Smelting & Refining Co., Toronto, Ont.

STOCK RACKS FOR BARS,**PIPING, ETC.**

New Britain Machine Co., New Britain, Conn.

STOCKS FOR DIES

Wells Bros. Co. of Canada, Galt, Ont.

STOCKS, PIPE

Butterfield & Co., Rock Island, Que.

STOOLS, STEEL, SHOP

Dennis Wire & Iron Works, London, Canada.

New Britain Mach. Co., New Britain, Conn.

STRAIGHTENING MACHINERY

Baird Machine Co., Bridgeport, Conn.

Bertrams, Ltd., Edinburgh, Scotland.

SWITCHES, RAILWAY

Can. Steel Foundries, Ltd., Montreal.

TACK (DOUBLE POINT) MACHINES

Sleeper & Hartley, Inc., Worcester, Mass.

TANKS, GASOLINE AND OIL

Dominion Forge & Stpg. Co., Walkerville, Ont.

The Jenckes Mach. Co., Ltd., Sherbrooke, Que.

MacKinnon, Holmes & Co., Sherbrooke, Que.

TANKS, STEEL, WATER PRESSURE

Can. Welding Works, Montreal, Que.

Jenckes Mach. Co., Sherbrooke, Que.

MacKinnon, Holmes Co., Sherbrooke, Toronto Iron Works, Ltd., Toronto.

TANK WAGONS

Jenckes Mach. Co., Sherbrooke, Que.
 MacKinnon, Holmes Co., Sherbrooke, Toronto Iron Works Ltd., Toronto.

TAPES, MEASURING

James Chesterman & Co., Ltd., Sheffield, Eng.

TAPPING MACHINES (PNEUMATIC)

Cleveland Pneumatic Tool Co. of Canada, Toronto.
 Greenfield Tap & Die Corp., Greenfield, Mass.

TAPPING MACHINES AND**ATTACHMENTS**

John Bertram & Sons Co., Dundas.
 Canada Machinery Corp., Galt, Ont.
 Garrin Machine Co., New York.
 The Geometric Tool Co., New Haven.
 J. H. Hall & Sons, Brantford, Ont.
 A. B. Jardine & Co., Hespeler.
 Landis Machine Co., Waynesboro, Pa.
 Manufacturers Equipment Co., Chicago, Ill.
 Modern Tool Co., Erie, Pa.
 Murchey Machine & Tool Co., Detroit.
 Niles-Bement-Pond Co., New York.
 Petrie of Montreal, Ltd., H. W., Montreal, Que.
 H. W. Petrie, Toronto.
 Ricker-Shafer Co., Erie, Pa.
 S. Starrett Co., Athol, Mass.
 Whitney Mfg. Co., Hartford, Conn.

TAPS, ADJUSTABLE

Baxter Co., Ltd., J. R., Montreal, Que.
 Geometric Tool Co., New Haven.
 Manufacturers Equipment Co., Chicago, Ill.
 Murchey Machine & Tool Co., Detroit.
 National-Acme Co., Cleveland, Ohio.
 Osborn (Canada), Ltd., Sam'l, Montreal, Que.

TAPS, COLLAPSIBLE

Geometric Tool Co., New Haven, Conn.
 Manufacturers Equipment Co., Chicago, Ill.
 Modern Tool Co., Erie, Pa.
 Murchey Machine & Tool Co., Detroit, Mich.
 Osborn (Canada), Ltd., Sam'l, Montreal, Que.
 Victor Tool Co., Waynesboro, Pa.

Equip YOUR Men with STEEL GRIP GLOVES

Munition makers and foundrymen in Canada, United States and England find them indispensable to Better Work—Safer Work.

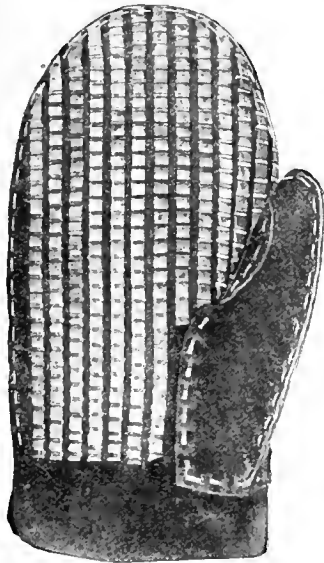

No. 62—This illustrates a mitt made of chrome tanned leather, reinforced with steel, over added strips of tough Napa leather. The thumb is reinforced with extra leather patch and steel ribbons on wearing surfaces. No cotton thread used—every seam sewed closed with steel thread. Price per dozen, \$10.50.



No. 65—This is a short glove; palm and fingers reinforced with steel ribbons; palm doubly protected with wide leather patch, tape fastener at wrist. This glove is made exceptionally strong and will stand the roughest sort of work. Price per dozen pairs (for all lefts or rights), \$9.00.

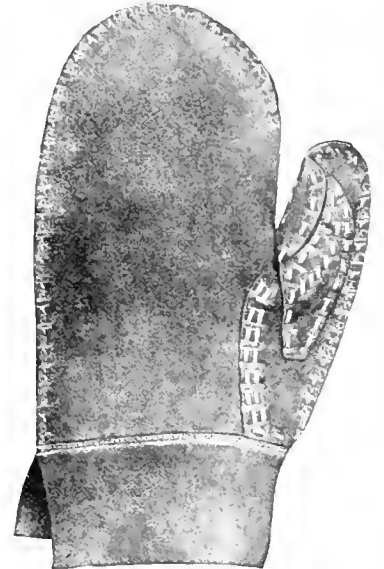

No. 678—A double service mitt that can be worn on either hand. No reinforcement on palm, but thumb protected and all seams sewed with steel thread. An ideal mitt for unloading light metal sheets, bars, etc. Per dozen, \$7.50.

Protection for the Workman in the Shop is as Necessary to Win the War as Protection for Our Men in the Trenches.

A Partial List of Users:

- American Steel Foundries.
- American Car & Foundry Co.
- E. W. Bliss Co.
- General Electric Co.
- International Harvester Co.
- U.S. Navy Yard at Portsmouth.
- Western Electric Co.
- White Sewing Machine Co. of Canada.
- The Pease Foundry Co. of Canada.
- Jenkins Bros., Limited.
- The Williams Manufacturing Co., Ltd., of Montreal.
- English Agent: R. E. Boulton, Leigh, Westbury, Wilts.

LET US SERVE YOU. WRITE

Sole Manufacturers

Hickory Steel-Grip Glove Company

Box B-6 CHICAGO, ILL.

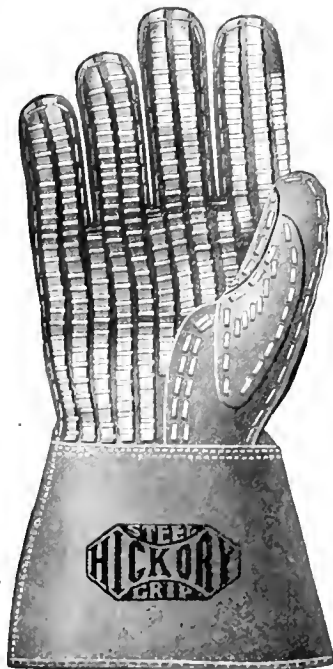

No. 64—Our gauntlet especially designed for sand blast work. Plain leather hand and cuff. Palm reinforced with steel over added strips of tough Napa leather. All seams sewed with steel. Price per dozen (for all rights or all lefts), \$12.50.



No. 64—Our gauntlet especially designed for sand blast work. Plain leather hand and cuff. Palm reinforced with steel over added strips of tough Napa leather. All seams sewed with steel. Price per dozen (for all rights or all lefts), \$12.50.

If any advertisement interests you, tear it out now and place with letters to be answered.

FAPS, DIES AND WRENCHES

Butterfield & Co., Rock Island, Que.
 Can. Fairbanks-Morse Co., Montreal
 Cleveland Twist Drill Co., Cleveland
 Foss & Hill Machy. Co., Montreal
 Geometric Tool Co., New Haven, Conn.
 A. B. Jardine & Co., Hespeler.
 Morse Twist Drill & Machine Co., New Bedford.
 Murchey Machine & Tool Co., Detroit.
 Osborn (Canada, Ltd.), Sam'l, Montreal, Que.
 Petrie of Montreal, Ltd., H. W., Montreal, Que.
 H. W. Petrie, Toronto.
 Pratt & Whitney Co., Dundas, Ont.
 L. S. Starrett Co., Athol, Mass.
 Wells Bros. Co. of Canada, Galt, Ont.

TESTING INSTRUMENTS**METALLURGICAL**

Holz, Herman A., 50 Church St., New York.
 Shore Instrument & Mfg. Co., New York City.

THERMOMETERS, ALL KINDS

Taylor Instrument Co., Rochester, N.Y.
 Bellevue Industrial Pharmace Co., Detroit, Mich.

TESTING LABORATORIES

Can. Inspection & Testing Lab., Montreal, Que.
 Toronto Testing Laboratory, Toronto.

THREAD-CUTTING MACHINES

Can. Fairbanks-Morse Co., Montreal.
 Curtis & Curtis Co., Bridgeport, Conn.
 Garlock-Walker Machinery Co., Toronto, Ont.
 Geometric Tool Co., New Haven, Conn.
 Lands Machine Co., Waynesboro, Pa.
 National-Acme Co., Cleveland, Ohio.
 National Machy. Co., Tiffin, Ohio.
 H. W. Petrie, Ltd., Toronto, Ont.
 Pratt & Whitney Co., Dundas, Ont.
 Wells Bros. Co. of Canada, Galt, Ont.

THREADING TOOLS

Rivett Lathe & Grinder Co., Brighton, Mass.

THREAD MILLERS

Gray Mfg. & Mach. Co., Toronto, Ont.
 T. C. M. Mfg. Co., Harrison, N.J.

TINSMITHS' TOOLS

Brown, Boggs & Co., Hamilton, Can.
 Steel Beading Brake Works, Ltd., Chatham, Ont.
 Peck, Stow & Wilcox, Cleveland, Ohio.

TIRE SETTING MACHINES, HYDRAULIC

William R. Perrio, Ltd., Toronto.
 West Tire Setter Co., Rochester, N.Y.

TOOL CASES

Union Tool Chest Works, Rochester, N.Y.

TOOL HOLDERS

Aikenhead Hardware Co., Toronto, Ont.
 Armstrong Bros. Tool Co., Chicago.
 Cleveland Twist Drill Co., Cleveland.
 Can. B. K. Morton, Toronto, Montreal.
 Deloro Smelting & Refining Co., Toronto, Ont.
 Modern Tool Co., Erie, Pa.
 Pratt & Whitney Co., Dundas, Ont.
 J. H. Williams Co., Brooklyn, N.Y.

TOOL POSTS, LATHE

Armstrong Bros. Tool Co., Chicago.

TOOL ROOM PARTITIONS

Canada Wire & Iron Goods Co., Hamilton.

TOOL STEEL

Atkins & Co., Wm., Sheffield, Eng.
 Armstrong, Whitworth, Ltd. of Canada, Montreal.
 Can. Fairbanks-Morse Co., Montreal.
 Can. B. K. Morton, Toronto, Montreal.
 Colonial Steel Co., Pittsburgh, Pa.
 Deloro Smelting & Refining Co., Toronto, Ont.
 H. A. Drury Co., Montreal.
 Firth & Sons, Thos., Montreal, Que.
 Hawkridge Bros. Co., Boston, Mass.
 Latrobe Electric Steel Co., Latrobe, Pa.
 Marshall, Geo. A., 70 Lombard, Toronto.
 Michigan Steel Exchange, Inc., Detroit, Mich.
 Osborn (Canada, Ltd.), Sam'l, Montreal, Que.
 H. W. Petrie, Ltd., Toronto, Ont.
 Swedish Steel & Imprioting Co., Montreal, Que.
 Vanadium-Alloys Steel Co., Pittsburgh, Pa.
 Vulcan Crucible Steel Co., Aliquippa, Pa.

TOOLS, BORING

Western Tool & Mfg. Co., Springfield, Ohio.

TOOLS, CUTTING OFF

Western Tool & Mfg. Co., Springfield, Ohio.

TOOLS, ELECTRIC

Independent Pneumatic Tool Co., Chicago, Ill.
 H. W. Petrie, Ltd., Montreal.
 R. E. T. Pringle, Ltd., Toronto, Ont.
 Standard Electrical Tool Co., Cincinnati, Ohio.
 Stow Mfg. Co., Binghamton, N.Y.
 A. R. Williams Machy. Co., Toronto.
 United States Elec. Tool Co., Cincinnati, O.

TOOLS, LATHE, PLANER, SLOTTER

Armstrong Bros. Tool Co., Chicago.

TOOLS, PNEUMATIC

Can. Ingersoll-Rand Co., Sherbrooke, Que.
 Cleveland Pneumatic Tool Co. of Canada, Toronto.
 Curtis Pneumatic Machinery Co., St. Louis, Mo.
 Garlock-Walker Machinery Co., Toronto, Ont.
 Independent Pneumatic Tool Co., Chicago, Ill.

TOOLS, SCREW MACHINE

Foster Machine Tool Co., Elkhart, Ind.

TOOLS, TURNING

Western Tool & Mfg. Co., Springfield, Ohio.

TORCHES, STEEL

Armstrong, Whitworth of Canada, Ltd., Montreal.
 Prest-O-Lite Co., Inc., Toronto, Ont.

TRACK SYSTEMS

Dillon Mfg. Co., Oshawa, Ont.
 Northern Crae Works, Walkerville.
 Whiting Foundry Equipment Co., Harvey, Ill.

TRAINS, TRACKLESS FACTORY

Mercury Mfg. Co., Chicago, Ill.

TRANSMISSION MACHINERY

American Pulley Co., Philadelphia, Pa.
 A. R. Williams Machy. Co., Toronto.
 Can. Bond Hanger & Cplg. Co., Alexandria, Ont.
 Can. Fairbanks-Morse Co., Montreal.
 Can. Drawn Steel Co., Hamilton, Ont.
 Hamilton Gear & Mach. Co., Toronto.
 Lyman Tube & Supply Co., Montreal, Que.
 Main Belting Co., Montreal.
 Morse Chain Co., Ithaca, N.Y.
 H. W. Petrie, Ltd., Toronto, Ont.
 The Smart-Turner Machine Co., Hamilton.

TRANSMISSION TOWERS

Curtis Pneumatic Machinery Co., St. Louis, Mo.
 Northern Crane Works, Walkerville.
 Tallman Brass & Metal Co., Hamilton.

TRUCKS, FACTORY, FREIGHT, ETC.

Canada Machinery Corp., Galt, Ont.
 Chapman Double Ball Bearing Co., Toronto.
 Mercury Mfg. Co., Chicago, Ill.
 Whiting Foundry Equipment Co., Harvey, Ill.

TRUCKS, LUMBER AND KILN

Sheldons, Ltd., Galt, Ont.
 Northern Crane Works, Walkerville.

TUBING, SEAMLESS, BRASS & COPPER

Hungerford Brass & Copper Co., New York, N.Y.
 Lyman Tube & Supply Co., Montreal, Que.
 Standard Tube & Fence Co., Woodstock, Ont.

TUMBLING BARRELS

Haird Machine Co., Bridgeport, Conn.
 Northern Crane Works, Walkerville.
 Whiting Foundry Equipment Co., Harvey, Ill.

TUNGSTEN FILAMENT COILING**MACHINERY**

Sleeper & Hartley, Inc., Worcester, Mass.

TAKENBUCKLES

Canadian Billings & Spencer, Ltd., Welland.

TURNABLES

Whiting Foundry Equipment Co., Harvey, Ill.

TURRET MACHINES

Brown & Sharpe Mfg. Co., Providence, R.I.
 Garlock-Walker Machinery Co., Toronto, Ont.
 New Britain Machine Co., New Britain, Conn.
 H. W. Petrie, Toronto.

PRATT & WHITNEY, HARTFORD, CONN.

Riverside Machinery Depot, Detroit, Mich.
 Warner & Swaser, Cleveland, O.
 Garvin Machine Co., New York.

TURBINE WATER WHEELS

Kenney Mach. Co., Sherbrooke, Que.

Wm. Kennedy & Sons, Ltd., Owen Sound, Ont.

UPSETTING AND BENDING**MACHINERY**

John Bertram & Sons Co., Dundas.
 Brown, Boggs Co., Ltd., Hamilton, Canada.
 Cook, Asa S., Co., Hartford, Conn.
 A. B. Jardine & Co., Hespeler.
 National Machy. Co., Tiffin, O.
 Canada Machinery Corp., Galt, Ont.
 Niles-Bement-Pond Co., New York.
 The Jenckes Mach. Co., Ltd., Sherbrooke, Que.
 Petrie of Montreal, Ltd., H. W., Montreal, Que.
 H. W. Petrie, Ltd., Toronto, Ont.
 A. R. Williams Machy. Co., Toronto.

VACUUM PUMPS

Can. Blower & Forge Co., Kitchener, Ont.
 Smart-Turner Machine Co., Hamilton, Ont.

VALVE LEATHERS

Can. B. K. Morton, Toronto, Montreal.
 Graton & Knight Mfg. Co., Montreal.

VALVE GRINDERS (PNEUMATIC)

Cleveland Pneumatic Tool Co. of Canada, Toronto

VALVES, FOOT

Smart-Turner Mach. Co., Hamilton.

VALVES, HYDRAULIC

Charles F. Elmes Eng. Works, Chicago, Ill.
 Metalwood Mfg. Co., Detroit, Mich.

VALVES, BACK PRESSURE, STEAM

Sheldons, Limited, Galt, Ont.

VENTILATING APPARATUS

Brantford Oven & Back Co., Brantford, Ont.
 Can. Blower & Forge Co., Kitchener, Ont.
 Sheldons, Limited, Galt.
 H. W. Petrie, Toronto.
 A. R. Williams Machy. Co., Toronto.

VICES, AIR OPERATED

Hannibal Mfg. Co., Chicago, Ill.

VICE STANDS, PORTABLE

New Britain Mach. Co., New Britain, Conn.

VICES, BENCH

Aikenhead Hardware Co., Toronto, Ont.
 Foss & Hill Machy. Co., Montreal.
 New Britain Machine Co., New Britain, Conn.
 H. W. Petrie, Ltd., Montreal.
 H. W. Petrie, Toronto.
 Welborne & Co., New York, N.Y.

VICES, PIPE

Aikenhead Hardware Co., Toronto, Ont.
 Butterfield & Co., Rock Island, Que.
 J. H. Williams & Co., Brooklyn, N.Y.

VICES, PLANER AND SHAPER

Aikenhead Hardware Co., Toronto, Ont.
 Skianer Chuck Co., New Britain, Conn.

WASHER MACHINES

National Machy. Co., Tiffin, Ohio.

WASHERS

Barnes, Wallace, Co., Bristol, Conn.
 Dillon Mfg. Co., Oshawa, Ont.
 Graton & Knight Mfg. Co., Worcester, Mass.
 Hungerford Brass & Copper Co., New York, N.Y.
 London Bolt & Hinge Works, London, Ont.
 Steel Co. of Canada, Ltd., Hamilton, Ont.

WATCHES, TIME STUDY

Silberberg, M. J., Chicago, Ill.

WATER PURIFYING AND SOFTENING APPARATUS

Wm. B. Scaife & Sons Co., Pittsburgh, Pa.

WATER CINDER MILLS

Whiting Foundry Equipment Co., Harvey, Ill.

WATER JACKETS

Can. Welding Works, Montreal, Que.

WATER TOWERS

The Jenckes Mach. Co., Ltd., Sherbrooke, Que.
 Toronto Iron Works, Ltd., Toronto.

WATER WHEELS

The Jenckes Mach. Co., Ltd., Sherbrooke, Que.
 Wm. Kennedy & Sons, Ltd., Owen Sound, Ont.
 Sleeper & Hartley, Inc., Worcester, Mass.

WAVING AND UNDERCUTTING

MACHINES AND ATTACHMENTS
 Gray Mfg. & Mach. Co., Toronto, Ont.

WELDING MASKS

Strong, Kennard & Nutt Co., Cleveland, Ohio.

WELDERS, ELECTRIC, SPOT,**BUTT, ETC.**

National Electric Welder Co., Warren, O.
 Tabor Mfg. Co., Philadelphia, Pa.
 Winfield Electric Welder Co., Warren, Ohio.

WELDING, WORK AND SUPPLIES

(Autogenous and Oxy-Acetylene). SEE OXY-ACETYLENE

WINCHES

John H. Hall & Sons, Brantford.
 Kennedy & Son, Wm., Owen Sound, Ont.
 Northern Crane Works, Walkerville.

WIRE COILING AND POINTING**MACHINERY**

Baird Machine Co., Bridgeport, Conn.
 F. B. Shuster Co., New Haven, Conn.
 Sleeper & Hartley, Inc., Worcester, Mass.

WIRE CLOTH AND PERFORATED**METALS**

Canada Wire & Iron Goods Co., Hamilton
 Hungerford Brass & Copper Co., U. T., New York

WIRE FORMING AND**STAMPING MACHINERY**

Baird Machine Co., Bridgeport, Conn.
 Brown, Boggs Co., Ltd., Hamilton, Canada.
 McClean & Son, F. W., Niagara Falls, Ont.
 F. B. Shuster Co., New Haven, Conn.

WIRE NAILS

Parmenter & Bulloch Co., Gaaanoque.
 Steel Co. of Canada, Ltd., Hamilton, Ont.

WIRE NAIL MACHINERY

National Machy. Co., Tiffin, Ohio
 Sleeper & Hartley, Inc., Worcester, Mass.
 A. R. Williams Machy. Co., Toronto.

WIRE SOLDER

Hungerford Brass & Copper Co., U. T., New York.

WIRE, STEEL, BRASS, COPPER,**BRONZE**

Hungerford Brass & Copper Co., U. T., New York
 Steel Co. of Canada, Ltd., Hamilton, Ont.

WOOD BORING MACHINES

Canada Machinery Corp., Galt, Ont.
 Cleveland Pneumatic Tool Co. of Canada, Toronto.
 Garlock-Walker Machinery Co., Toronto.
 Petrie of Montreal, Ltd., H. W., Montreal, Que.
 H. W. Petrie, Toronto.

WIRE STRAIGHTENERS AND CUTTERS

Baird Machine Co., Bridgeport, Conn.
 Brown, Boggs Co., Ltd., Hamilton, Canada.
 F. B. Shuster Co., New Haven, Conn.

WOODWORKING MACHINERY

Canada Machinery Corp., Galt, Ont.
 Can. Fairbanks-Morse Co., Montreal.
 Can. Ingersoll-Rand Co., Sherbrooke, Que.
 Garlock-Walker Machinery Co., Toronto.
 New Britain Machine Co., New Britain, Conn.
 Oliver Machy. Co., Grand Rapids, Mich.
 H. W. Petrie, Toronto.
 Petrie of Montreal, Ltd., H. W., Montreal, Que.
 Preston Woodworking Machy. Co., Preston, Ont.
 R. E. T. Pringle, Ltd., Toronto, Ont.
 Silver Mfg. Co., Salem, Ohio.
 A. R. Williams Machy. Co., Toronto

WOOD LATHES

Canada Machinery Corp., Galt, Ont.
 Garlock-Walker Machinery Co., Toronto, Ont.
 Oliver Machy. Co., Grand Rapids, Mich.

WOOD TRIMMERS.

Garlock-Walker Machinery Co., Toronto, Ont.
 Oliver Machy. Co., Grand Rapids, Mich.

WORKS STANDS, PORTABLE

New Britain Mach. Co., New Britain, Conn.

WRENCHES

Armstrong Bros. Tool Co., Chicago, Ill.
 Butterfield & Co., Rock Island, Que.
 Canadian Billings & Spencer, Ltd., Welland.
 Keystone Mfg. Co., Buffalo, N.Y.
 Wells Bros. Co. of Canada, Galt, Ont.
 Whitman & Barnes Mfg. Co., St. Catharines, Ont.
 Williams & Co., J. H., Brooklyn, N.Y.

WRENCHES, AUTOMOBILE NARROW**JAW AND MONKEY**

Bemis & Call Hdwe. & Tool Co., Springfield, Mass.
 Whitman & Barnes Mfg. Co., St. Catharines, Ont.

WRENCHES, PIPE, MONKEY, TAP

Aikenhead Hardware Co., Toronto, Ont.
 Bemis & Call Hdwe. & Tool Co., Springfield, Mass.
 Wells Bros. Co. of Canada, Galt, Ont.
 Whitman & Barnes Mfg. Co., St. Catharines, Ont.

WRENCHES, RATCHET AND BASIN

Bemis & Call Hdwe. & Tool Co., Springfield, Mass.
 Keystone Mfg. Co., Buffalo, N.Y.
 Whitman & Barnes Mfg. Co., St. Catharines, Ont.

WIRE STRAIGHTENING AND CUTTING**MACHINERY (AUTOMATIC)**

Sleeper & Hartley, Inc., Worcester, Mass.

FORGED—Not Milled

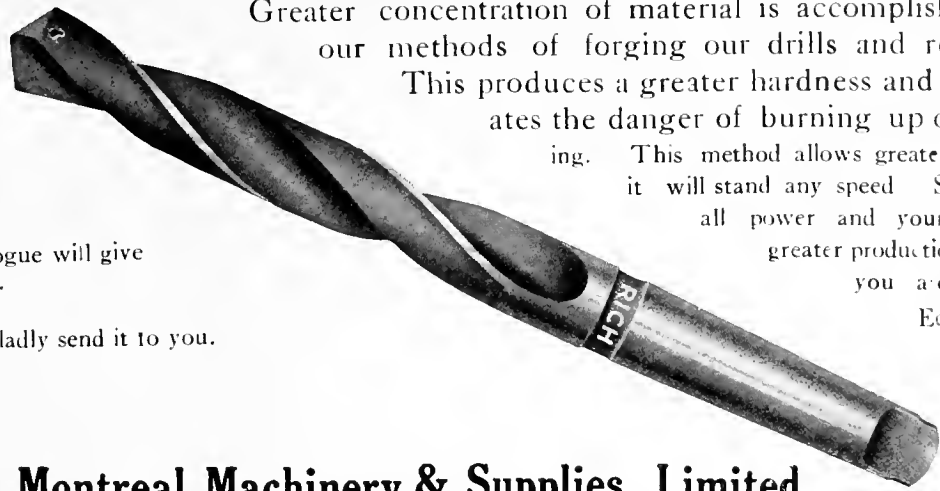

Greater concentration of material is accomplished by our methods of forging our drills and reamers.

This produces a greater hardness and eliminates the danger of burning up or binding.

This method allows greater speed—it will stand any speed. So put on all power and yours is for greater production when you are "Rich Equipped".

Our catalogue will give full details.

We will gladly send it to you.

Montreal Machinery & Supplies, Limited

260 ST. JAMES ST., MONTREAL

WESTERN REPRESENTATIVES:
Taylor & Arnold, McArthur Bldg.,
Winnipeg; R. F. Mather,
1050 Hamilton Street, Vancouver.

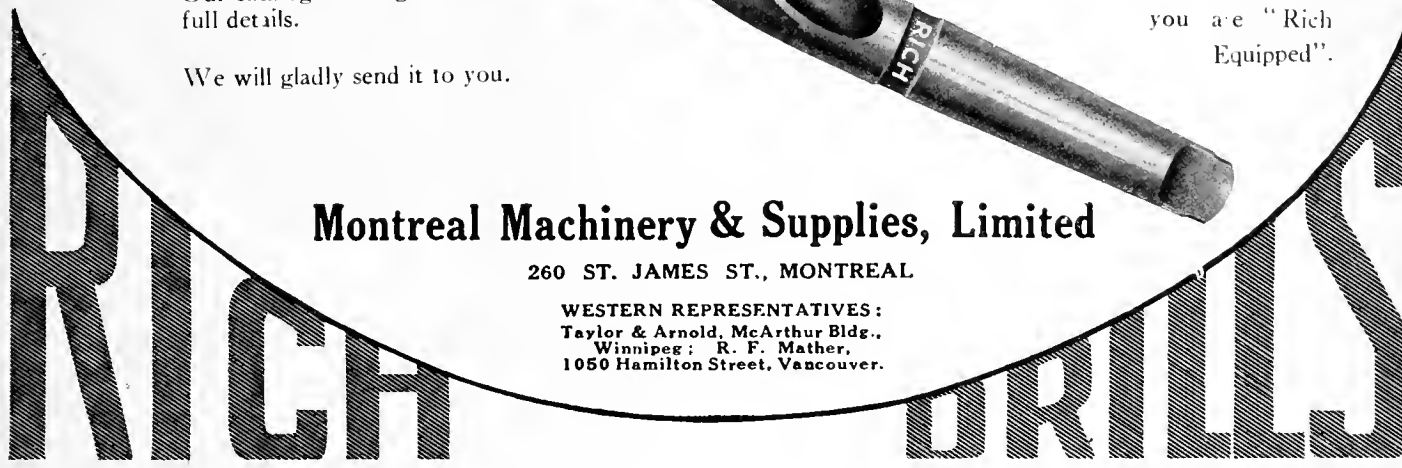

INDEX TO ADVERTISERS

A	
Adams, Ogden R.	221
Aikenhead Hardware Co.	143
Allen Mfg. Co.	62
American Pulley Co.	19
Armstrong Bros. Tool Co.	192
Armstrong, Whitworth of Canada.	10
Atkins & Co., Ltd., Wm.	12
Aurora Tool Works	217
B	
Babeock & Sons	146
Baird Machine Co.	209
Bainfield, E. J.	20
Bainfield, W. H., & Sons	144
Barkey Bros.	184
Barnes, W. P., & John	217
Barnes, Wallace, Co.	648
Bath & Co., Cyril J.	155
Beatty & Sons, M.	151
Beaudry & Co., Inc.	219
Bemis & Call Hardware & Tool Co.	174
Bernard Industrial Co., A.	65
Bertram & Sons Co., Ltd., John	205
Front cover and page 1	
Bertram's, Limited	145
Bilton Machine Tool Co.	199
Bliss Co., E. W.	37
Bloenthal, M.	154
Brantford Oven & Rack Co.	157
Bridgford Mach. Tool Works.	5
Bristol Company	207
Brownell Machy. Co.	179
Brown & Sharpe Mfg. Co.	213
Brown, Roggs Co., Ltd.	11
Brown's Copper & Brass Rolling Mills	205
Budden, Hanbury A.	146
Bullenfield & Co., Inc.	181
C	
Canada Machinery Corporation	Outside back cover
Canada Metal Co., Ltd.	172
Canada Wire & Iron Goods Co.	49
Can. B. K. Morton Co.	24
Can. Fairbanks-Morse Co.	82
Can. Billings & Spencer	191
Can. Bridge Co., Ltd.	151
Can. Desmond-Stephan Mfg. Co.	218
Can. Drawn Steel Co.	190
Can. Economic Lubricant Co.	47
Can. Harl Wheels, Ltd.	185

Can. Hoskins, Ltd.	174
Can. Ingersoll-Rand Co.	182, 184
Can. Inspection & Testing Laboratories, Ltd.	207
Can. Metal Products	163
Can. Steel Foundries, Ltd.	7
Can. S. K. F. Co., Ltd.	4
Can. Welding Works	178
Carborundum Co.	186
Catlyle Johnson Mach. Co.	8
Cataract Refining Co.	156
Chapman Double Ball Bearing Co.	50
Chesterman & Co., Ltd., Jas.	221
Cincinnati Iron & Steel Co.	157
Cincinnati Pulley Machy. Co.	219
Cleveland Twist Drill Co.	149
Cleveland Wire Spring Co.	145
Cliff Ammunition Co.	152
Colonial Steel Co.	16
Commercial Acetylene Welding Co.	191
Commercial Camera Co.	74
Consolidated Press Co.	135
Cook, Asa S.	208
Corbet Foundry & Mach. Co.	10
Cullen Machy. Co., C. W.	145
Curtis & Curtis Co.	28
Cushman Chuck Co.	209
D	
Davis-Bourneville Co.	210
Davis Machine Tool Co., W. F.	157
Deloro Smelting & Refining Co.	5
Delta File Works	112
De Mooy Mach. Co.	219
Diamond Saw & Stamping Works.	31
Duckow, Fred C.	115
Dominion Abrasive Wheel Co.	97
Dominion Belling Co., Ltd.	146
Dominion Bridge Co.	16
Dominion Iron & Wrecking Co.	39
Dominion Machinery Co.	158, 140
Dominion Metal Co.	58
Dominion Steel Foundry Co.	27
Drury Co., H. A.	18
Dunlop Tire & Rubber Goods Co., Ltd.	18
E	
Eaden Machine Screw Corp.	159
Elmes, Chas. F.	36
Eric Foundry Co.	26
Espan-Lucas Mach. Works	20

F	
Fairley-Davidson Steel Co., Inc.	13
Fetherstonhaugh & Co.	146
Firth & Sons, Ltd., Thos.	17
Fitzburg Grinding Mach. Co.	199
Fitzgerald & Co., W. H. J.	155
Fleck, Alexander, Limited	155
Ford-Smith Mach. Co., Ltd.	165, 197
Foss & Hill Machinery Co.	51, 66
Francis & Co.	209
Fraser Co., Warren F.	60
G	
Galt Mach. Screw Co.	163
Gardner Machine Co.	62, 63
Gardner & Sons, Robt.	46
Gardner-Walker Machy. Co.	168
Garvin Machine Co.	141
Geometric Tool Co.	141
Gibb Instrument Co.	175
Gilbert & Barker Mfg. Co.	156, 177
Goldard Tool Co.	168
Gooley & Ellum, Inc.	129
Grant Gear Works, Inc.	208
Grant Mfg. & Machine Co.	36
Gray Mfg. & Machine Co.	253
Greenfield Machine Co.	132, 210
H	
Hall & Sons, J. H.	27
Hamilton Gear & Machine Co.	4, 13
Hamilton Machine Tool Works.	41
Hanna & Co., M. A.	10
Hannifin Mfg. Co.	136
Harding Bros.	202, 202
Hawbridge Bros.	37
Hendley Machine Co.	130
Hepburn, Ltd., John T.	23
Hickox Steel Grip Glove Co.	225
High Speed Hammer Co.	16
Hill, Clarke & Co. of Chicago.	161
Hoyt Mach. Co.	223
Hockley Mach. Works.	60
Homer & Wilson	165
Hogson & Pettis Mfg. Co.	64, 65
Hoyt Metal Co.	75
Hunter Saw & Machine Co.	78
Hunter Saw & Machine Co.	28
Hunterford Brass & Copper Co.	24
Hurlbut Rogers Machinery Co.	76
Hyde Engineering Works.	29

I	
Ideal Tool & Mfg. Co.	180
Independent Pneumatic Tool Co.	189
Inter-Continental Machy. Co.	159
Iron Works, The	148
J	
Jacobs Mfg. Co.	178
Jardine Co., A. B.	169
Jencks Mach. Co.	9
Jobson, Geo. E.	147
Johnson Mach. Co., Catlyle	8
Joyce Co., Geo. A.	208
Jones & Glasco	221
K	
Kennedy & Sons, Wm.	22
Ker & Goodwin	145
Keystone Mfg. Co.	24
Keupsmith Mfg. Co.	57
L	
L'Air Liquide Society	191
Lambis Machine Co.	25
Lathro Electric Steel Co.	19
London Bolt & Nuge Co.	146
Lund-Fatigah Co.	151
M	
Mackintosh, Hemphill & Co.	17
MacNab Machy. Co., The John.	198
Magnoha Metal Co.	146
Marion & Marion	187
Manufacturers Equipment Co.	185
Marsh & Heathorn, Ltd.	188
Mathews & Co., Inc., Jas. H.	81
McAfee, J. J.	153
McArthur Reftms., Ltd.	52
McGow Bran It Machy. Co.	155
McDonald Co., H.	Inside back cover
McKenzie Machy. Co., D. K.	27
McLaren, Ltd., D. K.	206
McLaren Belling Co., J. C.	50
Mechanical Engineering Co.	175
Mechy Mfg. Co.	50
Mesta Mach. Co.	156
Metal Mfg. Service Co.	162
Metal-oid Mfg. Co.	47
Monarch Brass Mfg. Co.	162
Montgomery Smith & Co.	197

Here's a Masterpiece in Mechanical Construction

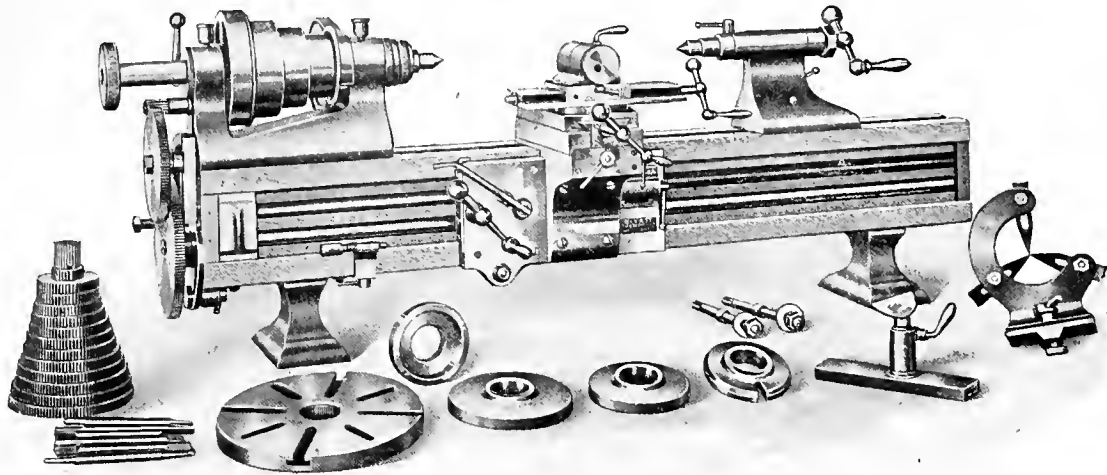

RIVETT PRECISION LATHES

Our 608

Illustration shows type No. 608, Back-Geared Precision Lathe. A Lathe of exceptional accuracy and highest grade finish, suitable for fine tool room, experimental and model work, and a wide range of light manufacturing. Equipped with compound Slide Rest and thread-cutting equipment. Designed for bench mounting, but may be furnished with combination stand and oil pan or oak cabinet and installed as an independent unit.

There are twelve tests of alignment made by experts on all Rivett Lathes, each test being conducted with minute care to ensure exactness without exception in any case. Then there is a close inspection of the completed machine, and when you buy it you may rest assured of getting a product that has all the Rivett excellence in quality and ability to produce.

Rivett Lathes are models of a model mechanical institution. We are keeping up with the spirit of the age in producing quality tools with profit-making speed.

Write for literature covering our products.

THE RIVETT LATHE & GRINDER CO.

BRIGHTON DISTRICT OF BOSTON

MASS., U.S.A.

Builders of Highest Grade Precision Tools

Mention this paper when writing advertisers. It willr it out now and place with letters to be answered.

