

*Hubert*

REPAIR, EVALUATION, MAINTENANCE, AND  
REHABILITATION RESEARCH PROGRAM

TECHNICAL REPORT NUMBER 013

# CASE HISTORIES OF CORPS BREAKWATER AND JETTY STRUCTURES

Report 3

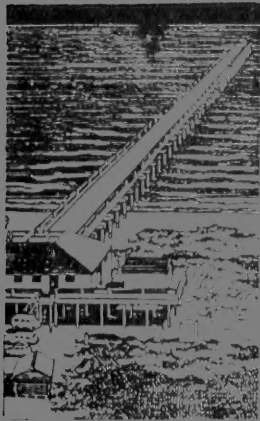
NORTH CENTRAL DIVISION

by

Robert R. Bottin, Jr.

Coastal Engineering Research Center

DEPARTMENT OF THE ARMY  
Waterways Experiment Station, Corps of Engineers  
PO Box 631, Vicksburg, Mississippi 39180-0631



June 1988

Report 3 of a Series

Approved For Public Release; Distribution Unlimited



Prepared for: DEPARTMENT OF THE ARMY  
US Army Corps of Engineers  
Washington, DC 20314-1000

Case Work Order 41001-32278 and Work Order 31,709

1. The first part of the document is a title page, which includes the title, author, and publication information.

2. The second part of the document is the abstract, which provides a brief summary of the main findings and conclusions of the study.

3. The third part of the document is the introduction, which sets the context for the study and outlines the research objectives.

4. The fourth part of the document is the methodology, which describes the research design, data collection methods, and statistical analysis.

5. The fifth part of the document is the results, which presents the findings of the study in a clear and concise manner.

6. The sixth part of the document is the discussion, which interprets the results and discusses their implications for the field.

7. The final part of the document is the conclusion, which summarizes the key findings and provides recommendations for future research.



REPORT DOCUMENTATION PAGE

1a REPORT SECURITY CLASSIFICATION <b>Unclassified</b>			1b RESTRICTIVE MARKINGS			
2a SECURITY CLASSIFICATION AUTHORITY			3 DISTRIBUTION / AVAILABILITY OF REPORT <b>Approved for public release; distribution unlimited</b>			
2b DECLASSIFICATION / DOWNGRADING SCHEDULE			5 MONITORING ORGANIZATION REPORT NUMBER(S)			
4 PERFORMING ORGANIZATION REPORT NUMBER(S) <b>Technical Report REMR-CO-3</b>			7a. NAME OF MONITORING ORGANIZATION			
6a. NAME OF PERFORMING ORGANIZATION <b>USAEWES, Coastal Engineering Research Center</b>		6b. OFFICE SYMBOL <i>(if applicable)</i>	7b. ADDRESS (City, State, and ZIP Code)			
6c. ADDRESS (City, State, and ZIP Code) <b>PO Box 631 Vicksburg, MS 39180-0631</b>			9. PROCUREMENT INSTRUMENT IDENTIFICATION NUMBER			
8a. NAME OF FUNDING / SPONSORING ORGANIZATION <b>US Army Corps of Engineers</b>		8b. OFFICE SYMBOL <i>(if applicable)</i>	10. SOURCE OF FUNDING NUMBERS <b>See reverse.</b>			
8c. ADDRESS (City, State, and ZIP Code) <b>Washington, DC 20314-1000</b>			PROGRAM ELEMENT NO.	PROJECT NO.	TASK NO.	WORK UNIT ACCESSION NO.
11. TITLE (Include Security Classification) <b>Case Histories of Corps Breakwater and Jetty Structures; Report 3: North Central Division</b>						
12. PERSONAL AUTHOR(S) <b>Bottin, Robert R, Jr.</b>						
13a. TYPE OF REPORT <b>Report 3 of a series</b>		13b. TIME COVERED <b>FROM Apr 85 TO Jan 87</b>		14. DATE OF REPORT (Year, Month, Day) <b>June 1988</b>		15. PAGE COUNT <b>437</b>
16. SUPPLEMENTARY NOTATION <b>Available from National Technical Information Service, 5285 Port Royal Road, Springfield, VA 22161.</b>						
17. COSATI CODES			18. SUBJECT TERMS (Continue on reverse if necessary and identify by block number)			
FIELD	GROUP	SUB-GROUP	Breakwater <b>REMR (Repair, Evaluation, Concrete armor units Maintenance, and Rehabilitation) Jetty Rubble-Mound structures</b>			
19. ABSTRACT (Continue on reverse if necessary and identify by block number)			<p>This report is third in a series of case histories of US Army Corps of Engineers (Corps) breakwater and jetty structures at nine Corps divisions. Case histories are presented for 107 projects which include jetty structures located within US Army Engineer Division, North Central (NCD), which encompasses the Great Lakes region. Presently there are approximately 481,570 lin ft of breakwater and jetty structures managed by NCD. These structures consist of timber crib, stone, sheet-pile, and concrete construction. Many have undergone repair and/or modification during their lifetime. A variety of repair methods have been utilized, including replacement of wooden structures, addition of stone, use of concrete and concrete caps, and placement of concrete armor units.</p>			
20 DISTRIBUTION / AVAILABILITY OF ABSTRACT <input checked="" type="checkbox"/> UNCLASSIFIED/UNLIMITED <input type="checkbox"/> SAME AS RPT. <input type="checkbox"/> DTIC USERS			21 ABSTRACT SECURITY CLASSIFICATION <b>Unclassified</b>			
22a. NAME OF RESPONSIBLE INDIVIDUAL			22b. TELEPHONE (Include Area Code)		22c. OFFICE SYMBOL	

Unclassified

**SECURITY CLASSIFICATION OF THIS PAGE**

10. SOURCE OF FUNDING NUMBERS (Continued).

Work Unit 32278 and Work Unit 31269.

Unclassified

**SECURITY CLASSIFICATION OF THIS PAGE**



## PREFACE

This report was prepared as part of the Coastal Problem Area of the Repair, Evaluation, Maintenance, and Rehabilitation (REMR) Research Program. The work was carried out jointly under Work Unit 32278, "Rehabilitation of Rubble-Mound Structure Toes," of the REMR Program and Work Unit 31269, "Stability of Breakwaters," of the Civil Works Coastal Area Program. For the REMR Program, Problem Area Monitor is Mr. John H. Lockhart, Jr., Office, Chief of Engineers (OCE), US Army Corps of Engineers (Corps). REMR Program Manager is Mr. William F. McCleese of the US Army Engineer Waterways Experiment Station's (WES's) Structures Laboratory, and Coastal Problem Area Leader is Mr. D. D. Davidson of WES's Coastal Engineering Research Center (CERC). Messrs. John G. Housley and Lockhart, OCE, are Technical Monitors of the Civil Works Coastal Program and Dr. Linwood C. Vincent is CERC Program Manager.

This report is third in a series of case histories of Corps breakwater and jetty structures at nine Corps divisions. The case histories contained herein were extracted from information obtained from several sources (where available) which included inspection reports, conferences, telephone conversations, project plans and specifications, project files and correspondence, design memorandums, literature reviews, model studies, surveys (bathymetric and topographic), survey reports, annual reports to the Chief of Engineers, House and Senate documents, and general and aerial photography. Unless otherwise noted, only prominent changes to the prototype structures subsequent to March 1986 are included in this report.

This work was conducted at WES during the period April 1985 - January 1987 under general direction of Dr. James R. Houston, Chief, CERC, and Mr. Charles C. Calhoun, Jr., Assistant Chief, CERC; and under direct supervision of Mr. C. Eugene Chatham, Jr., Chief, Wave Dynamics Division (CW), and Mr. D. D. Davidson, Wave Research Branch (CW-R), CW. This report was prepared by Mr. Robert R. Bottin, Jr., CW. Messrs. Robert D. Carver, Dennis G. Markle, R. Clay Baumgartner, C. Ray Herrington, and Willie G. Dubose, CW-R, conducted site inspections and collected much of the data contained herein. This report was typed by Ms. Myra E. Willis, CW-R, and edited by Ms. Shirley A. J. Hanshaw, Information Products Division, Information Technology Laboratory, WES.

COL Dwayne G. Lee, CE, was Commander and Director of WES during the publication of this report. Dr. Robert W. Whalin was Technical Director.

CONTENTS

	<u>Page</u>
PREFACE .....	1
CONVERSION FACTORS, NON-SI TO SI (METRIC) UNITS OF MEASUREMENT.....	3
PART I: INTRODUCTION.....	4
Background.....	4
Purpose.....	4
PART II: SUMMARY OF CORPS BREAKWATERS AND JETTY STRUCTURES IN NCD.....	6
REFERENCES.....	432

CONVERSION FACTORS, NON-SI TO SI (METRIC)  
UNITS OF MEASUREMENT

Non-SI units of measurement used in this report can be converted to SI (metric) units as follows:

<u>Multiply</u>	<u>By</u>	<u>To Obtain</u>
feet	0.3048	metres
inches	2.54	centimetres
miles (US statute)	1.609347	kilometres
pounds (mass)	0.4535924	kilograms
tons (2,000 pounds, mass)	907.1847	kilograms

CASE HISTORIES OF CORPS BREAKWATER AND JETTY STRUCTURES  
NORTH CENTRAL DIVISION

PART I: INTRODUCTION

Background

1. The Corps of Engineers (Corps) is responsible for a wide variety of coastal structures located along the Atlantic and Pacific Oceans, the gulf coast, the Great Lakes, the Hawaiian Islands, other islands, and inland waterways. Coastal improvements such as breakwaters and/or jetties are necessary to provide harbor protection and the safe passage of vessels. These structures are usually constructed on movable-bed materials and are continuously subjected to wave and current forces. Under these conditions, structural deterioration may occur and, in time, maintenance may be required when the structure fails to serve the needs of the project. Some projects have been maintained for 150 years or more. Methods of construction (and repair) have varied significantly during this time principally because of a better understanding of coastal processes, availability of construction materials, existing wave climates, regional construction practices, and economic considerations.

Purpose

2. The purposes of this report are to lend insight into the scope, magnitude, and history of coastal breakwaters and jetties under Corps jurisdiction; to determine their maintenance and repair history; to determine their methods of construction; to make this information available to Corps personnel; and to address objectives of the Repair, Evaluation, Maintenance, and Rehabilitation (REMR) Research Program. To this end, case histories of Corps breakwater and jetty structures have been developed to quantify past and present problem areas (if any), steps taken to rectify these problems, and subsequent evaluation of the remedial measures. General design guidance can be obtained from the solutions that have been most successful. Information in this report should be of particular value to Corps personnel in the US Army

Engineer Division, North Central (NCD), and its coastal districts and possibly to non-Corps personnel. Further research is being conducted to address problems where adequate solutions are lacking or where specific guidance is required (i.e. general armor stability, toe protection, localized damage, use of dissimilar armor, wave runup, and overtopping).

## PART II: SUMMARY OF CORPS BREAKWATER AND JETTY STRUCTURES IN NCD

3. NCD has a total of 107 projects located in the Great Lakes region which include breakwater and/or jetty structures. NCD refers to many structures as piers which actually function as jetties. Therefore, the term "pier" used in this report will carry the same meaning as the term "jetty." Seventy of the projects are within US Army Engineer District, Detroit's (NCE's), area of responsibility; six are located within US Army Engineer District, Chicago's (NCC's) boundaries; and thirty-one are under the jurisdiction of US Army Engineer District, Buffalo (NCB). Figures 1-3 show the locations of these projects along the Great Lakes. Overall, there is a total of about 481,570 lin ft\* of breakwater and/or jetty structures in NCD. Breakwaters account for approximately 69 percent of this total, and jetty structures account for the remaining 31 percent. Construction materials used for these structures include stone, concrete, steel sheetpiling, woodpiling, timber, and concrete armor units (dolosse used at Cleveland Harbor, Ohio).

4. Twenty-one projects are located on the United States shoreline of Lake Superior, thirty-eight on the Lake Michigan shoreline, fifteen on the Lake Huron shoreline, one on the Lake St. Clair shoreline (small lake between Lake Huron and Lake Michigan), twenty-two on the southern shore of Lake Erie, and ten on the Lake Ontario shoreline. Structures within NCD have experienced problems in all four major REMR problem areas (runup and overtopping, localized damage, toe stability, and use of dissimilar armor). Many of NCD's projects have deteriorated and have been repaired or modified since construction.

5. Breakwaters and jetties in NCD have been constructed on top of existing sediments (usually fine to coarse sand) in water depths ranging from 8 to 70 ft. These structures have crest elevations (el) ranging from 4 to 18 ft and crest widths ranging from 1 to about 60 ft. Side slopes of stone structures range from 1V:1.25H to 1V:2H. Design guidance for breakwater cross-sections (stone sizes, crest height, width, etc.) is provided by the Shore Protection Manual (SPM) (1984) or other appropriate Corps engineering manuals. Several of NCD's projects have been model tested at the US Army Engineer Waterways Experiment Station.

---

\* A table of factors for converting non-SI units of measurement to SI (metric) units is presented on page 3.

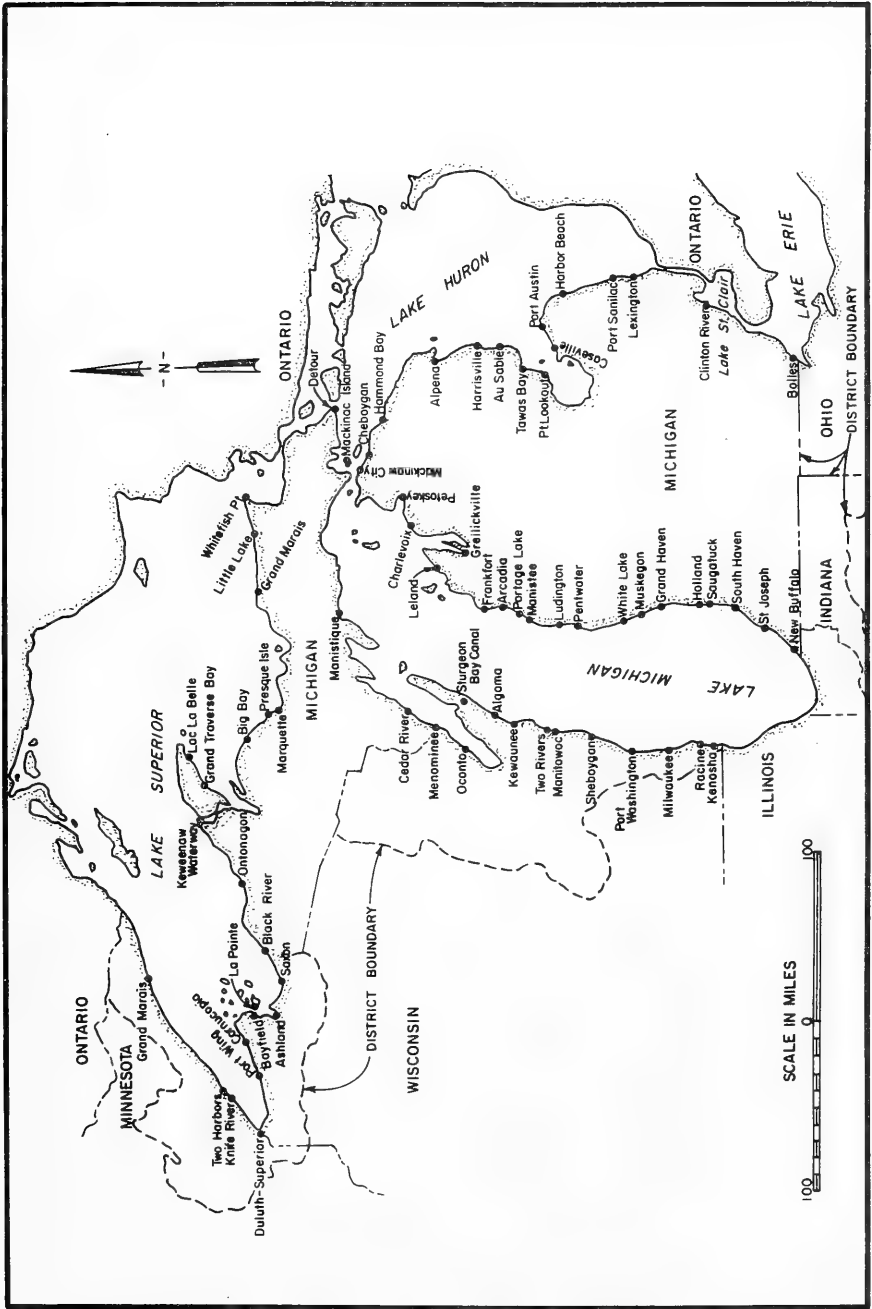


Figure 1. Location of NCE's breakwater and jetty projects

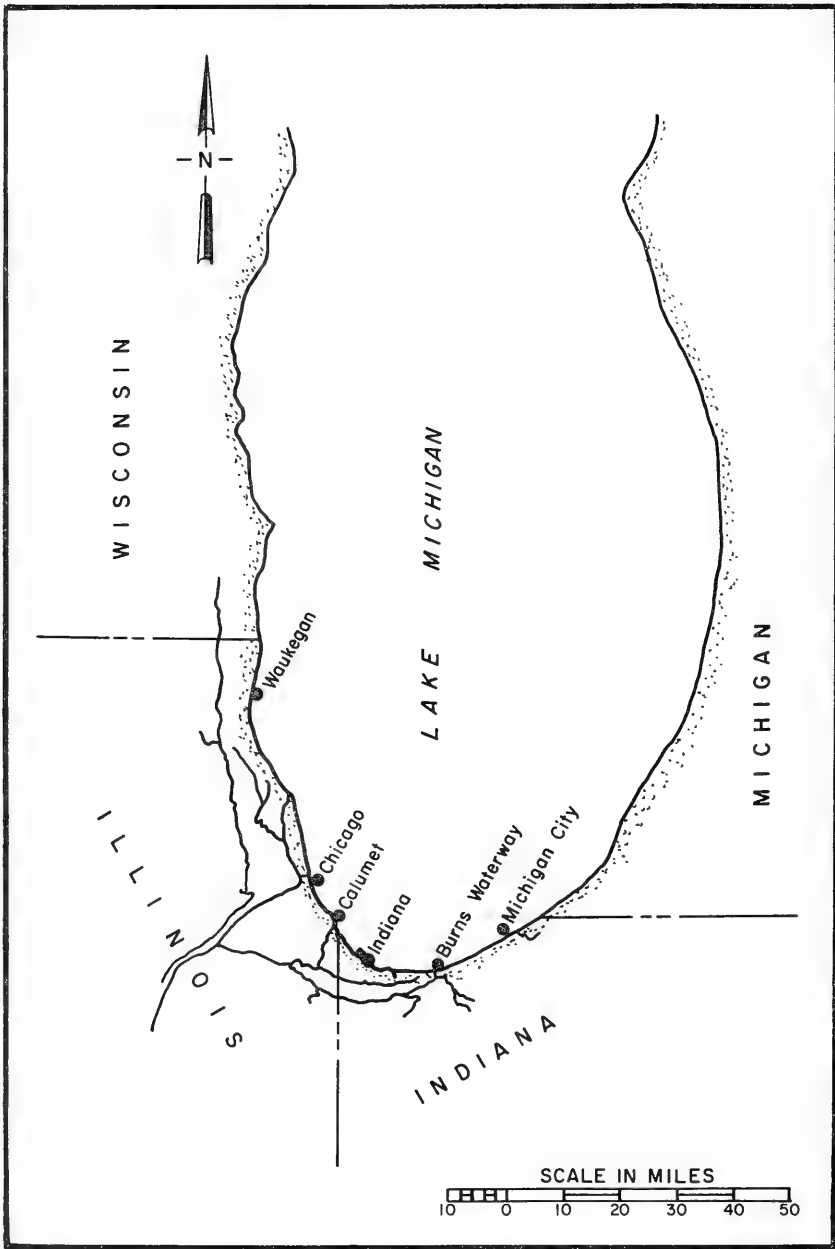


Figure 2. Location of NCC's breakwater and jetty projects



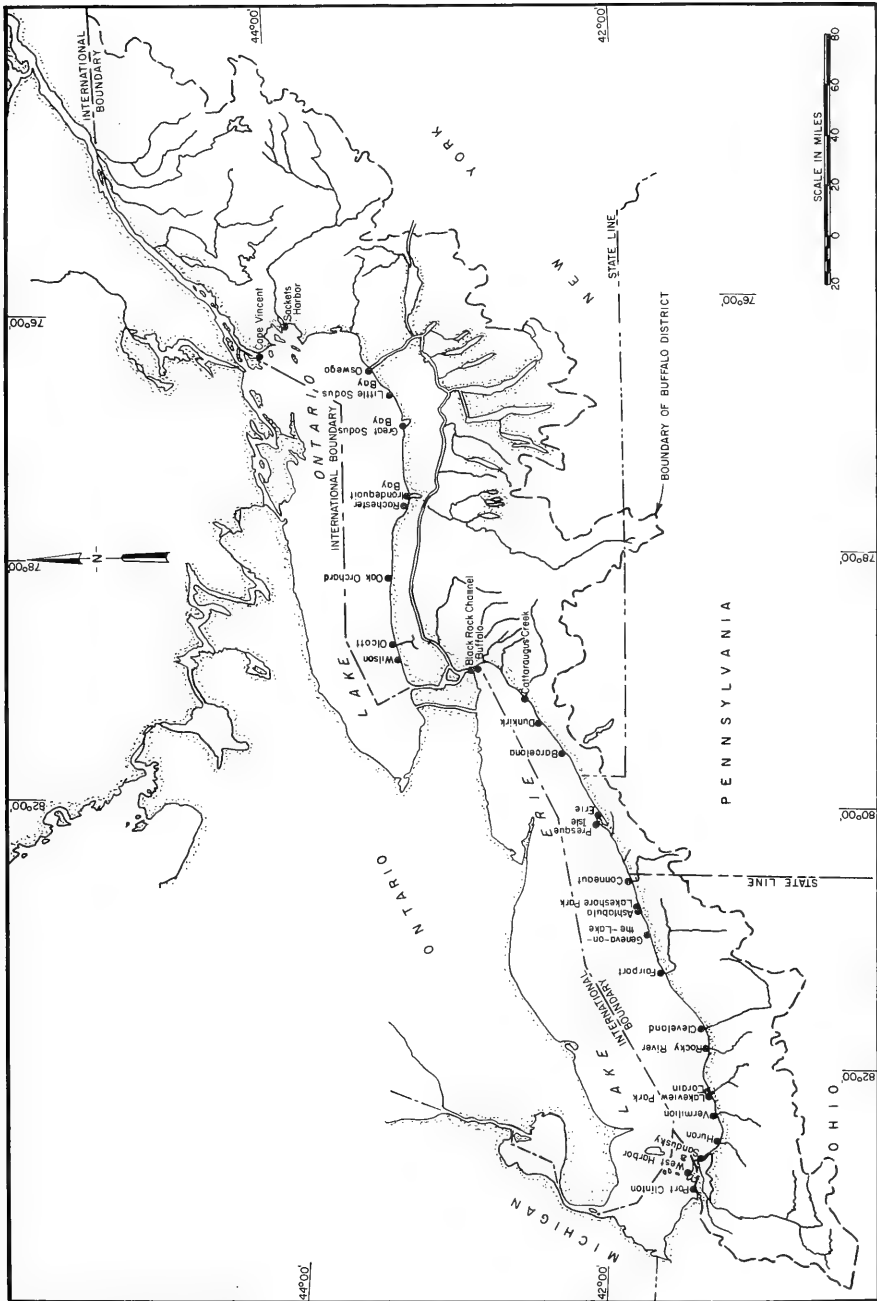


Figure 3. Location of NCB's breakwater and jetty projects

6. The elevations of various structures and depths on the Great Lakes are based on low water datum (lwd) which is referenced to mean water level (mwl) at Father Point, Quebec, according to the International Great Lakes Datum (IGLD) of 1955. Figure 4 shows a profile of the Great Lakes region. Horizontal and vertical distances have been distorted somewhat to convey visual impression.

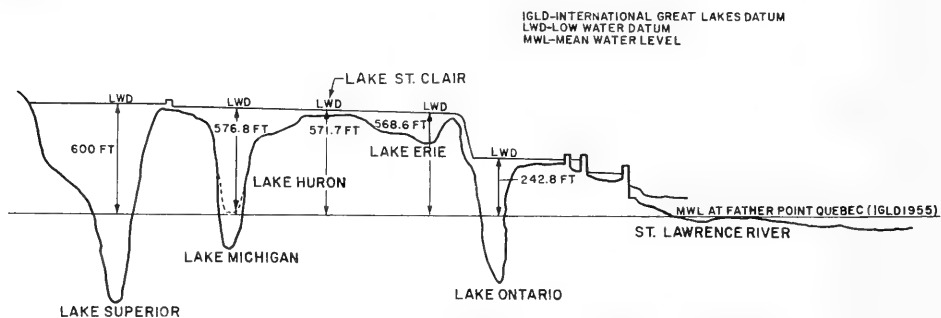


Figure 4. Profile of the Great Lakes region (lwd referenced to mwl at Father Point, Quebec according to IGLD of 1955)

7. Case histories for NCD's breakwater and jetty structures are presented in Tables 1-107. Figures depicting structure alignments, cross sections, and aerial photographs for some sites accompany the various tables. Sites are presented in the order of west to east and counterclockwise along the lake shoreline (i.e., the first site being presented on the northwest end of Lake Superior and the last on the east coast of Lake Ontario). General characteristics of the structures at the various sites are shown in the following tabulation:

Table	Location	Structure Type & No.*	Construction Materials**	Structure Length ft	Date of Origin	Improve- ment†
<u>Lake Superior</u>						
1	Grand Marais Harbor, Minn.	B(3)	TC,S,C,CC	1,719	1883	M
2	Two Harbors, Minn.	B(2)	TC,S,CC	2,528	1893	M
3	Knife River Harbor, Minn.	B(2)	TC,S,TD	245	1957	M
4	Duluth-Superior Harbor, Minn. and Wis.	B(2) P(4)	TC,S,C,CC,SSP	13,650	1898	R
5	Port Wing Harbor, Wis.	P(2)	WP,S,CC,SSP	1,806	1903	R
6	Cornucopia Harbor, Wis.	P(2)	WP,SSP,S,CSSP	1,468	1957	N
7	Bayfield Harbor, Wis.	B(2)	CSSP,S	242	1936	N
8	La Pointe Harbor, Wis.	B(1)	CSSP,S,SSP	200	1967	N
9	Ashland Harbor, Wis.	B(1)	TC,S,CC	8,000	1889	N
10	Saxon Harbor, Wis.	B(2)	S,SSP,CSSP	1,033	1965	N
11	Black River Harbor, Mich.	B(2)	S	1,380	1957	N
12	Ontonagon Harbor, Mich.	P(2)	TC,S,WP,SSP, C,CC	4,782	1868	N

(Continued)

\* Type (B - breakwater, J - jetty, and P - pier) and number of structures (i.e., B(3) indicates 3 breakwaters).

\*\* C - concrete, CC - concrete cap, S - stone, TD - timber deck, TC - timber crib, WP - wood piling, CSSP - cellular steel sheet pile, SSP - steel sheet pile.

† M - modification, R - rehabilitation, N - none, D - dolosse, Z-W - Z-wall, G - Gabion, SP - Sta-pod.

(Sheet 1 of 8)

<u>Table</u>	<u>Location</u>	<u>Structure Type &amp; No.</u>	<u>Construction Materials</u>	<u>Structure Length ft</u>	<u>Date of Origin</u>	<u>Improve- ment</u>
<u>Lake Superior (Continued)</u>						
13	Keweenaw Waterway, Mich.	B(3)	TC,S,SSP,C, CC	8,844	1860	N
14	Lac La Belle Harbor, Mich.	B(2)	SSP,CSSP,S	1,179	1959	N
15	Grand Traverse Bay Harbor, Mich.	P(2)	SSP,CSSP,S, CC	1,618	1949	M
16	Big Bay Harbor, Mich.	B(2)	S,SSP,CSSP	1,258	1960	R
17	Presque Isle Harbor, Mich.	B(1)	TC,S,C	2,816	1897	R
18	Marquette Harbor, Mich.	B(1)	TC,S,CC	4,510	1867	R
19	Grand Marais Harbor, Mich.	P(2)	TC,S,CC,WP, CSSP	4,409	1883	R
20	Little Lake Harbor, Mich.	B(2)	S,CSSP	1,270	1964	N
21	Whitefish Point Harbor, Mich.	B(3)	CSSP,SSP,S, CC	1,364	1968	N
<u>Lake Michigan</u>						
22	Manistique Harbor, Mich.	B(2) P(1)	TC,S,CC,WP	4,046	1887	M,R
23	Cedar River Harbor, Mich.	P(2)	WP,S	1,100	1883	M
24	Memominee Harbor, Mich.	P(2)	WP,S,C,CC,SSP	3,912	1871	R
25	Oconto Harbor, Wis.	P(1)	WP,S,CSSP,CC	2,144	1883	R
26	Sturgeon Bay Canal, Wis.	B(2)	TC,CC,S,WP	2,688	1873	N

(Continued)

(Sheet 2 of 8)

<u>Table</u>	<u>Location</u>	<u>Structure Type &amp; No.</u>	<u>Construction Materials</u>	<u>Structure Length ft</u>	<u>Date of Origin</u>	<u>Improve- ment</u>
<u>Lake Michigan (Continued)</u>						
27	Algoma Harbor, Wis.	P(1) B(2)	WP,TC,CC,S	2,632	1871	N
28	Kewaunee Harbor, Wis.	P(2) B(1)	WP,SSP,S,CC	5,456	1881	R
29	Two Rivers Harbor, Wis.	P(2)	WP,TC,S,CC	3,313	1872	R
30	Manitowoc Harbor, Wis.	P(1) B(2)	WP,TC,S,C,CC	4,904	1895	R
31	Sheboygan Harbor, Wis.	P(2) B(1)	WP,TC,S,CC	6,443	1873	R
32	Port Washington Harbor, Wis.	B(3)	S,C,CSSP, SSP,WP	4,713	1934	M
33	Milwaukee Harbor, Wis.	P(2) B(2)	TC,S,C,CC, SSP,WP	22,882	1855	R
34	Racine Harbor, Wis.	P(2) B(2)	TC,S,C,CC, WP,SSP	5,509	1900	R
35	Kenosha Harbor, Wis.	P(2) B(1)	TC,C,CC,WP, SSP	3,048	1899	R
36	Waukegan Harbor, Ill.	P(2) B(1)	TC,C,CC,S, WP,SSP	6,545	1903	M,R
37	Chicago Harbor, Ill.	P(1) B(2)	TC,C,CC,SSP, S	20,351	1874	M,R
38	Calumet Harbor, Ill. and Ind.	B(2)	TC,S,CC,CSSP	11,721	1904	R
39	Indiana Harbor, Ind.	B(2)	S,C	3,645	1922	M
40	Burns Waterway Harbor, Ind.	B(1)	S	5,830	1968	R

(Continued)

(Sheet 3 of 8)

<u>Table</u>	<u>Location</u>	<u>Structure Type &amp; No.</u>	<u>Construction Materials</u>	<u>Structure Length ft</u>	<u>Date of Origin</u>	<u>Improve- ment</u>
<u>Lake Michigan (Continued)</u>						
41	Michigan City Harbor, Ind.	B(2) P(2)	TC, S, CC, SSP, WP	5,415	1884	R
42	New Buffalo Harbor, Mich.	B(2)	S, SSP	2,045	1975	R
43	Saint Joseph Harbor, Mich.	P(2)	TC, CC, SSP, WP, S	5,361	1836	R
44	South Haven Harbor, Mich.	P(2)	TC, S, CC, SSP, WP	2,395	1868	R
45	Saugatuck Harbor, Mich.	P(2)	TC, S, CC, SSP, WP	5,016	1904	R
46	Holland Harbor, Mich.	B(2) P(2)	TC, S, CC, SSP, WP	2,953	1868	R
47	Grand Haven Harbor, Mich.	P(2)	TC, S, CC, SSP, WP	2,931	1867	R
48	Muskegon Harbor, Mich.	B(2) P(2)	C, S, CC, WP, SSP	7,480	1868	M, R
49	White Lake Harbor, Mich.	P(2)	TC, S, WP, CC	1,518	1870	N
50	Pentwater Harbor, Mich.	P(2)	S, TC, WP, CC	1,421	1868	M
51	Ludington Harbor, Mich.	B(2) P(2)	S, TC, CC, WP, SSP	8,069	1866	R
52	Manistee Harbor, Mich.	B(1) P(2)	TC, WP, SSP, S, CC	4,410	1912	R
53	Portage Lake Harbor, Mich.	P(2)	TC, S, CC, WP	2,632	1883	R
54	Arcadia Harbor, Mich.	P(2)	TC, S, SSP, CC	1,410	1909	R

(Continued)

(Sheet 4 of 8)

<u>Table</u>	<u>Location</u>	<u>Structure Type &amp; No.</u>	<u>Construction Materials</u>	<u>Structure Length ft</u>	<u>Date of Origin</u>	<u>Improve- ment</u>
<u>Lake Michigan (Continued)</u>						
55	Frankfort Harbor, Mich.	P(2) B(2)	TC,C,S,WP,CC, SSP,CSSP	6,027	1868	R
56	Leland Harbor, Mich.	P(1) B(1)	S,CSSP,SSP,WP	1,675	1936	M,R
57	Greilickville Harbor, Mich.	B(3)	SSP,S,CC,CSSP	2,005	1950	M
58	Charlevoix Harbor, Mich.	P(2)	TC,S,CSSP,WP CC,SSP	1,688	1872	R
59	Petoskey Harbor, Mich.	B(1)	TC,S,CC	1,250	1895	R
<u>Lake Huron</u>						
60	Detour Harbor, Mich.	B(1)	S,CC	1,310	1982	N
61	Mackinac Island Harbor, Mich.	B(2)	S	1,860	1914	M
62	Mackinaw City Harbor, Mich.	B(2)	S,C	630	1955	N
63	Cheboygan Harbor, Mich.	B(1)	S,C	775	1968	R
64	Hammond Bay Harbor, Mich.	B(2)	S	1,905	1965	R
65	Alpena Harbor, Mich.	B(1)	S	750	1939	M
66	Harrisville Harbor, Mich.	B(2)	S	2,780	1959	M,R
67	Au Sable Harbor, Mich.	J(2)	CSSP,SSP,S,CC	2,407	1962	R
68	Tawas Bay Harbor, Mich.	B(1)	SSP,CC,S	1,564	1977	N

(Continued)

(Sheet 5 of 8)

Table	Location	Structure Type & No.	Construction Materials	Structure Length ft	Date of Origin	Improve- ment
<u>Lake Huron (Continued)</u>						
69	Point Lookout Harbor, Mich.	B(2)	S	7,800	1972	R
70	Caseville Harbor, Mich.	B(1)	S	1,780	1964	R
71	Port Austin Harbor, Mich.	B(1)	CSSP,S,CC	1,926	1959	R
72	Harbor Beach, Mich.	B(3)	TC,S,CC	7,876	1874	R
73	Port Sanilac Harbor, Mich.	B(2)	CSSP,S,CC, SSP	2,575	1951	M
74	Lexington Harbor, Mich.	B(2)	S	2,595	1976	N
<u>Lake St. Clair</u>						
75	Clinton River, Mich.	B(1)	S	1,400	1966	N
<u>Lake Erie</u>						
76	Bolles Harbor, Mich.	J(1)	S	400	1970	N
77	Port Clinton Harbor, Ohio	J(2)	S,WP,SSP,CC	3,330	1893	R
78	West Harbor, Ohio	B(2)	S,C	2,925	1982	N
79	Sandusky Harbor, Ohio	J(1)	S	6,000	1897	R
80	Huron Harbor, Ohio	P(1) B(1)	S,TC,CC,SSP, WP	4,973	1827	R
81	Vermilion Harbor, Ohio	P(2) B(1)	TC,S,CSSP,CC	2,656	1836	M,R
82	Lakeview Park, Ohio	B(3)	S	750	1977	N

(Continued)

(Sheet 6 of 8)



<u>Table</u>	<u>Location</u>	<u>Structure Type &amp; No.</u>	<u>Construction Materials</u>	<u>Structure Length ft</u>	<u>Date of Origin</u>	<u>Improve- ment</u>
<u>Lake Erie (Continued)</u>						
83	Lorain Harbor, Ohio	P(2) B(3)	TC,S,CC,CSSP	12,541	1828	M,R
84	Rocky River Harbor, Ohio	P(1)	S	900	1873	R
85	Cleveland Harbor, Ohio	P(2) B(2)	TC,S,CC,D	32,560	1875	M,R
86	Fairport Harbor, Ohio	P(2) B(2)	TC,S,CC,SSP, C,CSSP	12,105	1868	M,R
87	Geneva-on-the-Lake, Ohio	B(3)	SP,G,Z-W	270	1978	N
88	Ashtabula Harbor, Ohio	B(3)	S,TC	13,051	1897	M,R
89	Lakeshore Park, Ohio	B(3)	S	375	1983	N
90	Conneaut Harbor, Ohio	P(1) B(2)	S,CSSP,TC,CC	11,100	1894	M,R
91	Presque Isle Peninsula, Pa.	B(3)	S	375	1978	N
92	Erie Harbor, Pa.	P(2)	TC,S,CC,SSP	5,463	1825	R
93	Barcelona Harbor, N.Y.	B(2)	CSSP,CC,S, SSP	2,057	1960	M
94	Dunkirk Harbor, N.Y.	P(1) B(3)	C,S,CC	6,888	1868	M,R
95	Cattaraugus Harbor, N.Y.	B(2)	S,C	2,450	1983	N
96	Buffalo Harbor, N.Y.	B(5)	TC,S,CC	24,433	1869	M,R
97	Black Rock Channel, N.Y.	P(1)	TC,S,CC,TD	10,507	1822	M,R

(Continued)

(Sheet 7 or 8)

<u>Table</u>	<u>Location</u>	<u>Structure Type &amp; No.</u>	<u>Construction Materials</u>	<u>Structure Length ft</u>	<u>Date of Origin</u>	<u>Improve- ment</u>
<u>Lake Ontario</u>						
98	Wilson Harbor, N.Y.	P(2)	SSP,S,CC,TD, TC	1,331	1878	M,R
99	Olcott Harbor, N.Y.	P(2)	TC,SSP,S,CC, TD	1,723	1918	R
100	Oak Orchard Harbor, N.Y.	P(2) B(1)	S,CSSP,CC	2,120	1975	N
101	Rochester Harbor, N.Y.	P(2)	S,TC,SSP,CC	5,770	1835	R
102	Irondequoit Bay, N.Y.	B(1) J(1)	S	2,100	1985	N
103	Great Sodus Bay Harbor, N.Y.	P(2) B(1)	TC,S,SSP,CC	4,527	1910	R
104	Little Sodus Bay Harbor, N.Y.	P(2) B(1)	TC,S,SSP,CC	5,237	1867	R
105	Oswego Harbor, N.Y.	B(3)	TC,S,CC	10,265	1882	M,R
106	Sackets Harbor, N.Y.	J(1)	WP,S	164	1888	N
107	Cape Vincent Harbor, N.Y.	B(1)	TC,S,CC	1,381	1915	R

(Concluded)

(Sheet 8 of 8)

Table 1  
Grand Marais Harbor Breakwaters  
Grand Marais, Minnesota

Date(s)	Construction and Rehabilitation History
1883-1884	A 300-ft-long rock-filled timber-crib breakwater was constructed at the site (Figure 5, Sections E and F) during this period. The outer 48 ft of the structure (Figures 5 and 6, Section E) was built 40 ft in width, and the remaining 252 ft (Figures 5 and 6, Section F) was constructed 30 ft in width.
1901-1902	A 350-ft-long rock-filled timber crib breakwater was constructed west of the first structure during this period (Figures 5 and 6, Section D). The structure was built 24 ft wide.
1925	A concrete cap (superstructure) was constructed on the outer 48 ft of the structure built during 1883-84. The crest el was +7 ft lwd (Figure 6, Section E).
1926	A concrete cap (superstructure) was completed on the 30-ft-wide, 252-ft-long structure built during 1883-84. The crest was constructed at an el of +7 ft lwd (Figure 6, Section F).
1933	A concrete cap (superstructure) was installed on the breakwater built during 1901-02. The crest el was +7 ft lwd. Heavy riprap was placed on both sides of the structure (Figure 6, Section D). Also in 1933 a 43-ft-long concrete breakwater connecting the east breakwater to shore was constructed (Figure 5, Section G). The structure was 12 ft wide and had a crest el of +7 ft lwd (Figure 6, Section G).
1959	Construction of a 921-ft-long rubble-mound inner breakwater was completed (Figure 5, Section A). Cover stone, a minimum of 2 tons, was placed on the outer 550 ft of the structure, and 1-ton (minimum) cover stone was placed on the remaining part of the breakwater. The crest el was +6 ft lwd with an 8-ft width. The structure had side slopes of 1V:1.5H (Figure 6, Section A). The inner breakwaters were model tested (Fenwick 1941, 1944).
1972	A 65-ft-long rubble-mound breakwater connecting the shore to an island (Figure 5, Section B) and a 40-ft-long rubble-mound breakwater connecting the island to the east breakwater (Figure 5, Section C) were constructed. These structures were built with stone ranging from 5 to 20 tons and had crest els of +6 ft lwd (Figure 6, Sections B and C). Model testing of these structures was conducted (Fenwick 1941).
1981	A survey of the structures revealed spalling of the concrete at several locations, particularly on the lakeside of the east breakwater. The rubble-mound shore connection of the west breakwater required

(Continued)

Table 1 (Concluded)

Date(s)	Construction and Rehabilitation History
	additional stone to raise the el in some locations above the water level. The concrete cap of the west breakwater was noted shifting, cracking, separating, and/or tilting in some locations. Concrete spalling also was noted.
1986	The general condition of the east and west breakwaters is considered fair. The rubble-mound inner breakwater is in good condition.

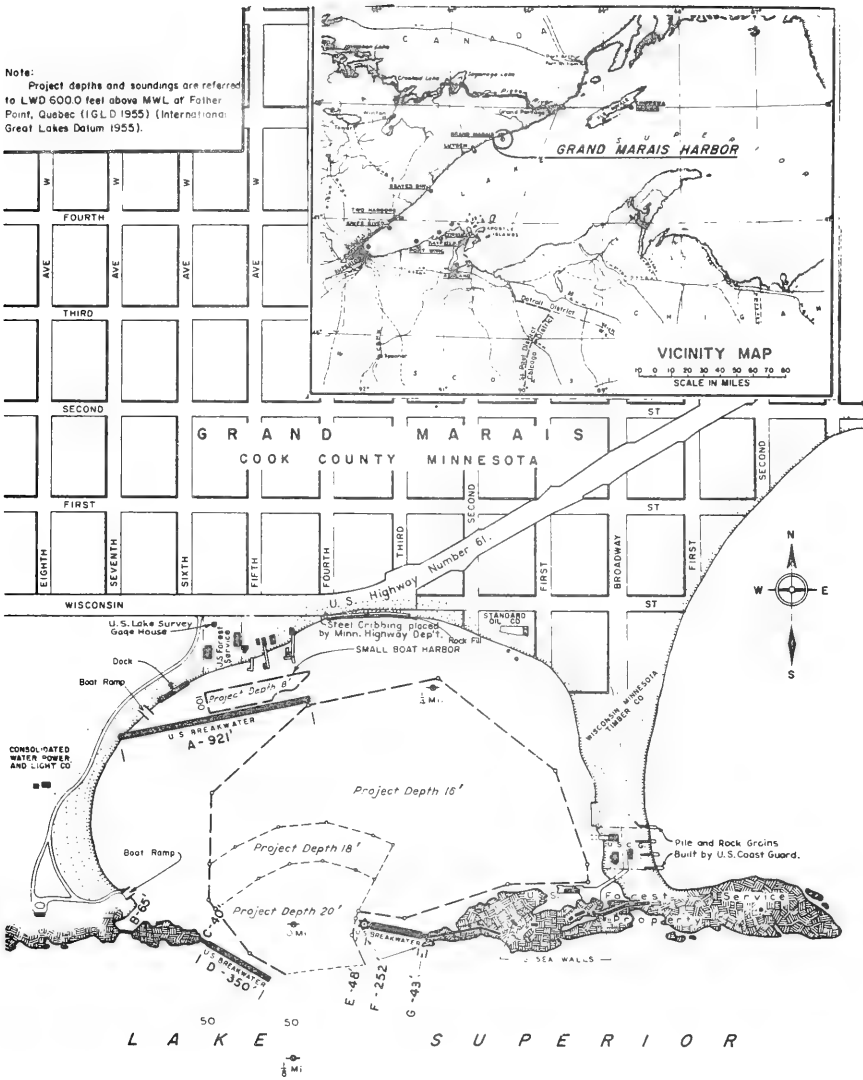


Figure 5. Grand Marais Harbor, Minnesota

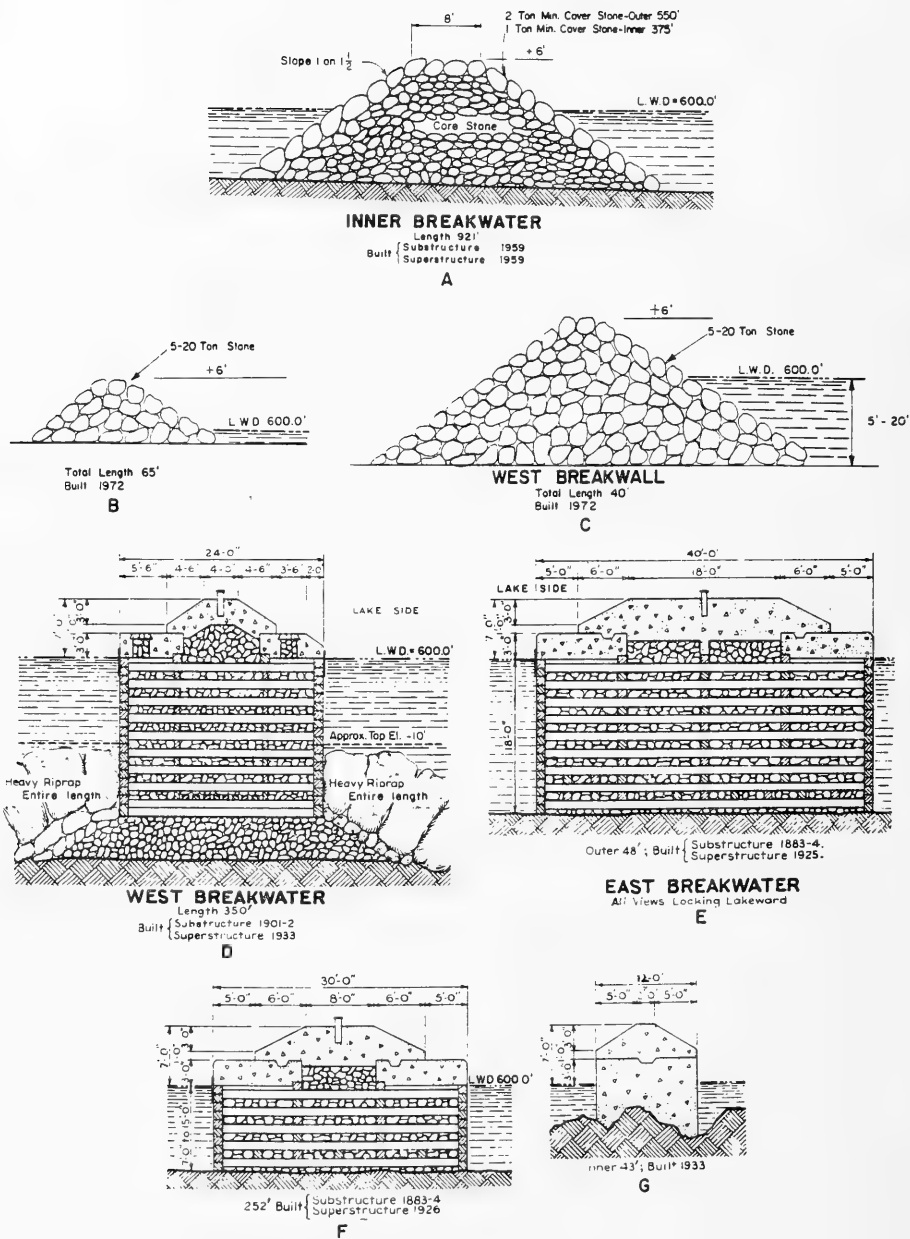
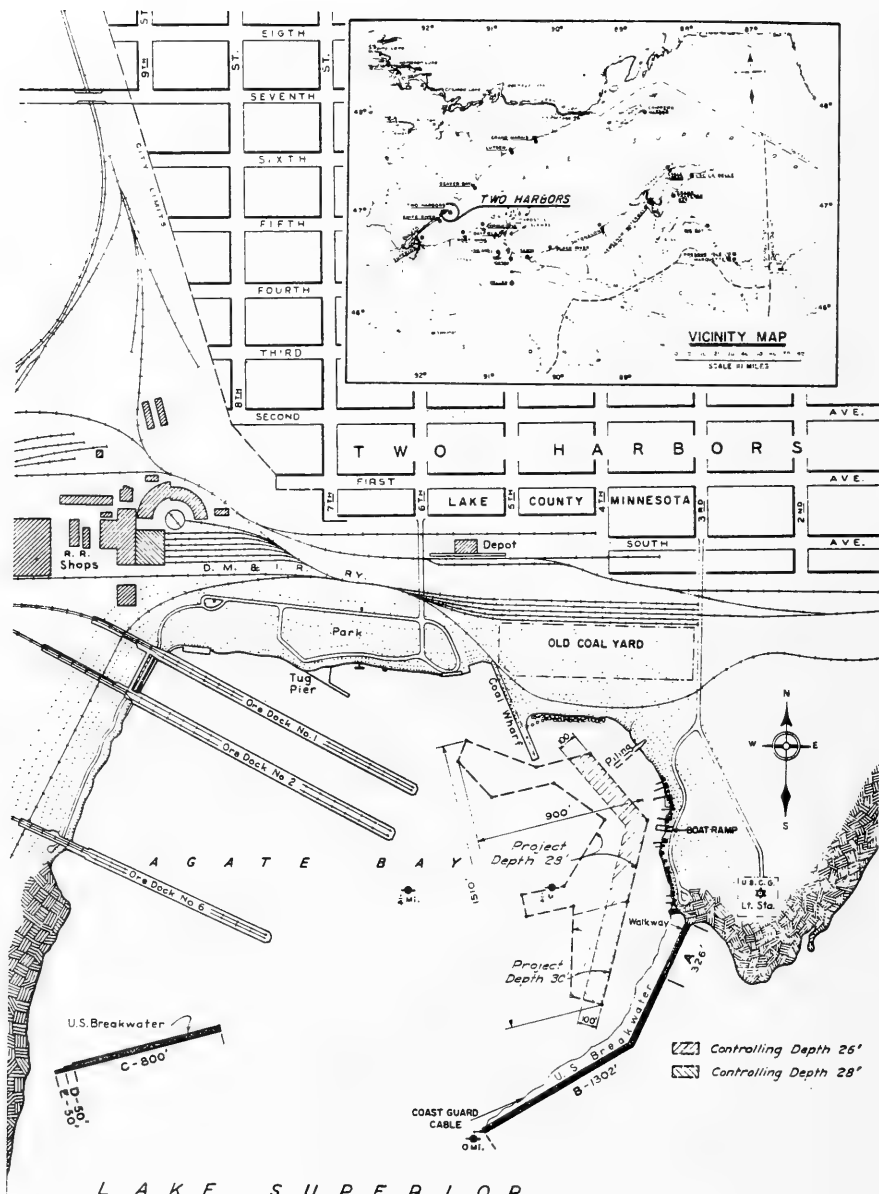


Figure 6. Typical breakwater cross sections, Grand Marais Harbor, Minnesota

Table 2  
Two Harbors Breakwaters  
Two Harbors, Minnesota

<u>Date(s)</u>	<u>Construction and Rehabilitation History</u>
1893	Construction of a 900-ft-long stone-filled timber crib breakwater (Figure 7, Sections C, D, and E) was completed at the site. The cribs were built on rubble-mound foundations. The easternmost 800 ft of the structure was 24 ft wide (Figure 8, Section C), the adjacent 50-ft portion was 20 ft wide (Figure 8, Section D), and the westernmost 50 ft of the breakwater was 16 ft wide (Figure 8, Section E).
1933- 1934	A concrete cap (superstructure) was built on the breakwater. The crest el was +7 ft lwd (Figure 8, Sections C, D, and E).
1947- 1949	A 1,302-ft-long stone-filled timber crib breakwater on a rubble-mound base was constructed (Figures 7 and 8, Section B). The structure was 30 ft wide. The rubble-mound base consisted of 5-ton cover stone on 1V:1.5H side slopes.
1948	Construction of a 326-ft-long rubble-mound shore connection of the east breakwater was completed (Figures 7 and 8, section A). The crest was 12 ft wide with a +6 ft crest el.
1948- 1950	A concrete cap (superstructure) was built on the 1,302-ft-long breakwater that was completed during 1947-49 (Figure 8, Section B). The crest el of the structure was increased to +8 ft.
1986	Since construction, records indicate that localized damage of the breakwaters has occurred and has been repaired during routine maintenance. The structures are presently in good condition.



L A K E S U P E R I O R

Figure 7: Two Harbors, Minnesota





Table 3  
Knife River Harbor Breakwater  
Knife River, Minnesota

<u>Date(s)</u>	<u>Construction and Rehabilitation History</u>
1957- 1958	Construction of a 245-ft-long breakwater occurred at the site (Figure 9) during this time frame. The shoreward 215 ft of the structure was of rubble-mound construction, and the lakeward 30 ft was a stone-filled timber crib breakwater (Figure 10). The rubble-mound portion of the breakwater had a crest width of 8 ft and an el of +8 ft lwd. Side slopes of 1V:1.5H were constructed, and armor stone ranging from 3 to 5 tons was used. The timber crib structure was 30 ft wide with a crest el of +9 ft lwd. It was constructed on a stone mattress and had a timber deck. Rock was placed around the toe of the structure comprised of cover stone ranging from 1 to 5 tons. After construction it was noted that a design deficiency existed in that the breakwater did not effectively protect the harbor entrance from adverse wave conditions from northeasterly storms.
1974	A modification to the project authorized the construction of a 451-ft-long rubble-mound breakwater with four 62.8-ft diam steel sheet-pile cells (250 ft) at its head (Figure 9). Construction of the breakwater has not been initiated.
1986	Since the original breakwater was completed, it has sustained some localized damage which was repaired during routine maintenance. The structure is presently in good condition.

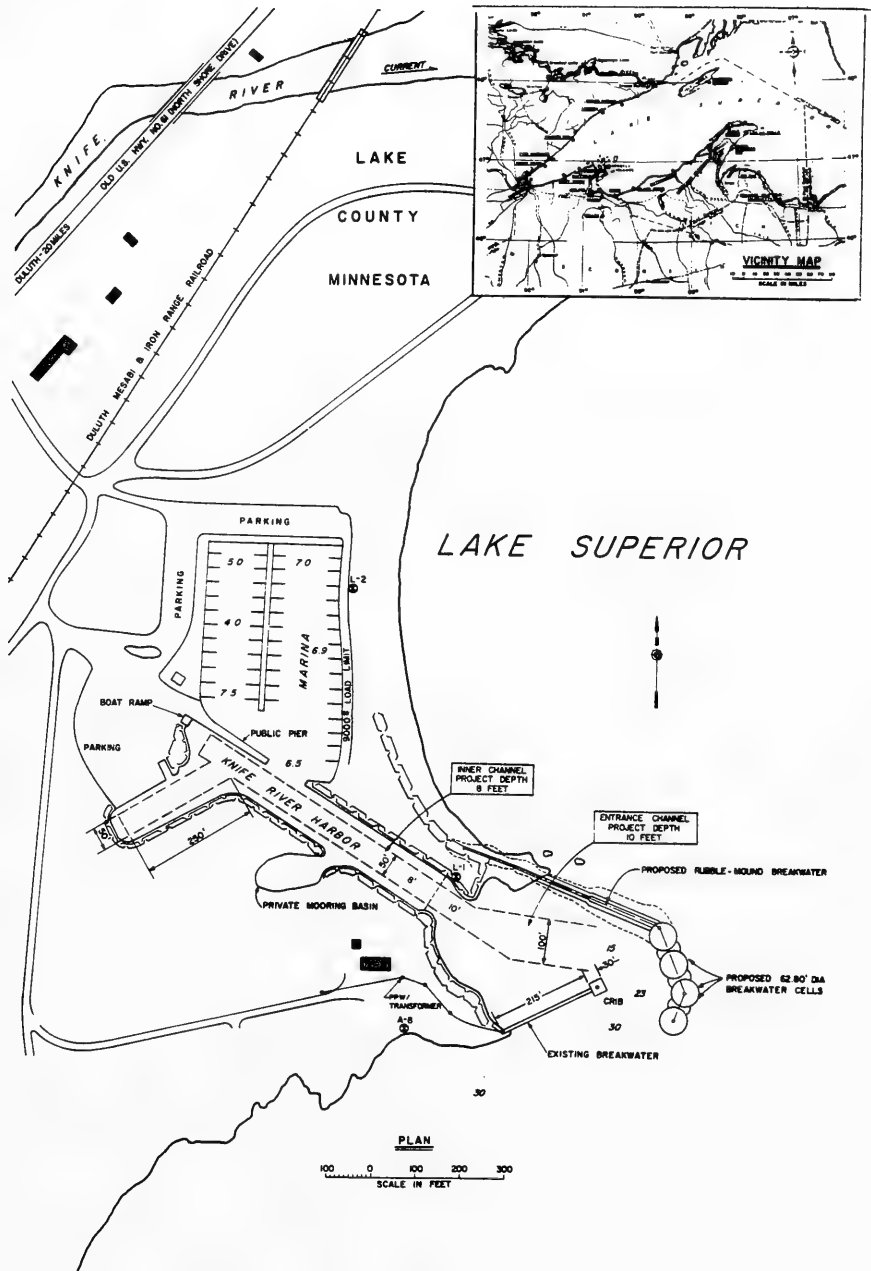
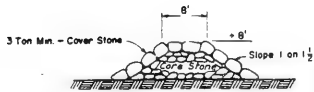
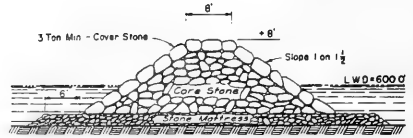


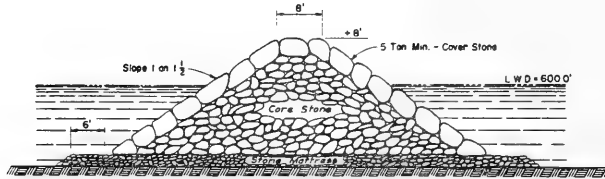
Figure 9. Knife River Harbor, Minnesota



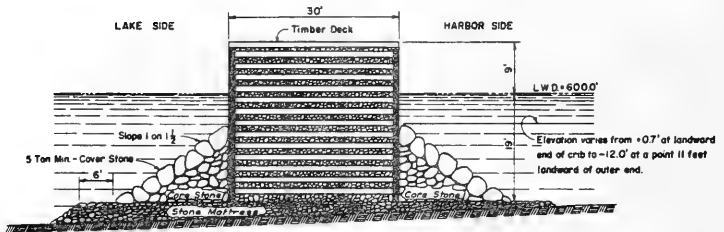
**RUBBLE MOUND**  
Landward End to L.W.D. Shore Line  
Built 1957-1958



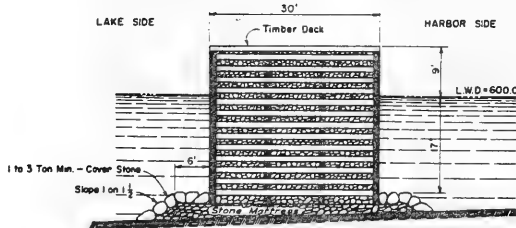
**RUBBLE MOUND**  
L.W.D. Shore Line to -10 Contour  
Built 1957-1958



**RUBBLE MOUND**  
-10 Contour to Landward End of Crib  
Built 1957-1958



**TIMBER CRIB**  
Landward 25'  
Built 1957-1958



**TIMBER CRIB**  
Landward 5'  
Built 1957-1958

Figure 10. Typical structure cross sections,  
Knife River Harbor, Minnesota

Table 4

Duluth-Superior Harbor Structures  
Duluth-Superior, Minnesota and Wisconsin

Date(s)	Construction and Rehabilitation History
1898- 1900	The construction of two 1,720-ft-long entrance piers at Duluth Ship Canal (Figure 11) occurred during this period. These were timber crib structures filled with stone and timber (oak and pine) with a concrete superstructure (monolith blocks). The el of the superstructure ranged from +10 to +18 ft lwd with widths of 24 ft to 36 ft at the structure heads (Figure 12).
1904- 1907	Construction of a 2,096-ft-long north pier and a 1,581-ft-long south pier progressed at Superior Entry (Figure 11). These structures were built with concrete. Crest widths ranged from 8 to 11 ft with els ranging from +10 to +16 ft lwd (Figure 12).
1908- 1913	During this time, a 4,137-ft-long north breakwater and a 1,866-ft-long south breakwater were constructed (Figure 11) at Superior Entry. The pierheads and breakwater heads were timber cribs filled with stone and timber. Crest els were +10 ft lwd, and widths were 40 and 31 ft, respectively, for the pierheads and breakwater heads (Figure 12). The breakwater trunks were rubble-mound structures installed at el +8 ft lwd (Figure 12) with 1V:1.5H side slopes. Ten-ton armor stone was used. The shoreward ends consisted of concrete structures installed on rubble (Figure 12). Crest widths were 12 ft, and crest els were +8 ft lwd.
1933	A 530-ft-long rubble-mound shore connection was installed on the inner end of the north breakwater at Superior Entry. It consisted of an 8-ft crest width at an el of +8 ft lwd with 1-V:1.5-H side slopes.
1949	Thirty feet of the outer south pierhead at Duluth Ship Canal was rebuilt, and 406 ft of the south pier at Superior Entry was rebuilt. These consisted of steel sheet-pile walls and concrete (Figure 12). The pierhead at Duluth Ship Canal was built with a crest width of 14 ft at an el of +13 ft lwd. The pier at Superior Entry was 8 ft wide with an el of +10 ft lwd.
1956	Longitudinal cracks on the pierhead in the middle of the superstructures were repaired at Duluth Ship Canal. The repair consisted of horizontal tie bolts through each monolith and reinforcing bars drilled and grouted through the tunnel. After the bars were in place, the tunnel was filled with concrete. No separation of the monolith has occurred since then.
1957- 1958	Twenty-six feet at the inner end of the south pierhead and 1,019 ft at the south pier at Superior Entry were rebuilt using steel sheet-pile walls and concrete (Figure 12).

(Continued)

Table 4 (Concluded)

---

<u>Date(s)</u>	<u>Construction and Rehabilitation History</u>
1960	A hydraulic model investigation (Wilson 1963) was conducted at Superior Entry to improve wave conditions in the navigation channel and at the ore docks located opposite the entry. Proposed plans involved detached breakwaters lakeward of the existing entrance. Improvements were never constructed at the site.
1977- 1978	The concrete superstructures of the north and south piers and the substructures at Duluth Ship Canal were inspected. The timber cribs, riprap, and armor protection were determined to be, generally, in good condition. Small gaps were noted along the joints of the cribs, but the timbers were still firm, and no warping was noted. Some cracks were noted in the monolith blocks, but there was no misalignment or settlement; and the joints were all tight.
1984	An inspection of the piers at Duluth Ship Canal was conducted. The north pier was in need of work both above and below the surface, and the south pier was reported in very good condition. An inspection of the Superior Entry inner piers indicated that the structures were in fair condition. In general, the structures needed maintenance, and repairs were done.
1986	In general, very little maintenance has been needed since construction of the project. Minor patching of spalling concrete has been attempted with generally poor results. The structures overall are presently in fair condition.

---







Table 5  
Port Wing Harbor Piers  
Port Wing, Wisconsin

<u>Date(s)</u>	<u>Construction and Rehabilitation History</u>
1903- 1904	The construction of an 800-ft-long east pier and a 45-ft-long pile revetment progressed at the site (Figure 13).
1906	The outer 555 ft of the west pier (Figure 13, Section A) was constructed. The structure consisted of wood piles filled with wood slabs and capped with stone. It was 11 ft wide and installed at an el of +5.5 ft lwd.
1917	The inner 224 ft of the west pier was constructed. The cross section of the structure was the same as the outer portion built in 1906.
1946	The outer portion of the west pier (45.6 ft long) was rebuilt (Figures 13 and 14, Section B). Steel sheetpiling and stone were used to increase the width of the structure to 18.7 ft. Large stone was used to cap the structure. The crest el was +5 ft lwd.
1949- 1950	The east pier and pile revetment were rebuilt. The east pier consisted of wood piles filled with stone and capped with a concrete and stone superstructure. The crest el of the structure was +5.5 ft lwd with a 19.75-ft width, and the length was decreased to 446.5 ft. Stone was placed on the lakeside of the pier (Figure 14, Section C). The pile revetment consisted of woodpiling filled with sand and capped with concrete. It was increased to 388 ft in length. The el was +4.0 ft lwd, and stone was placed on the channel side (Figure 14, Section D).
1961	Steel sheetpiling was placed on the shoreward end of the west pier for a distance of 192.4 ft (Figures 13 and 14, Section E). The structure was 1.0 ft wide at an el of +5.5 ft lwd. A rock berm was installed on each side of the structure (Figure 14, Section E). Steel sheetpiling was also placed on the channel side of the west pier for a distance of 779 ft (Figures 13 and 14, Section A).
1986	The structures presently are in good condition.

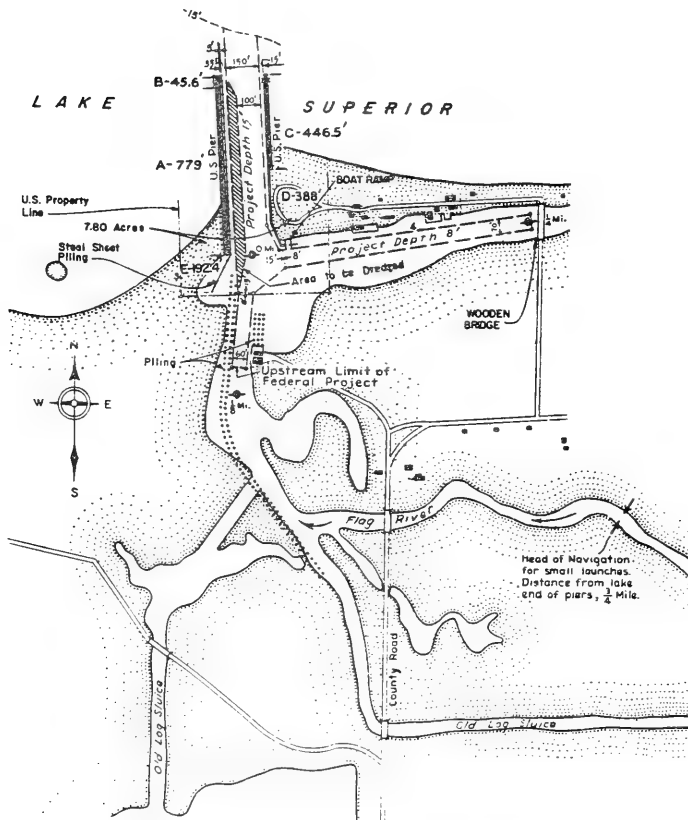
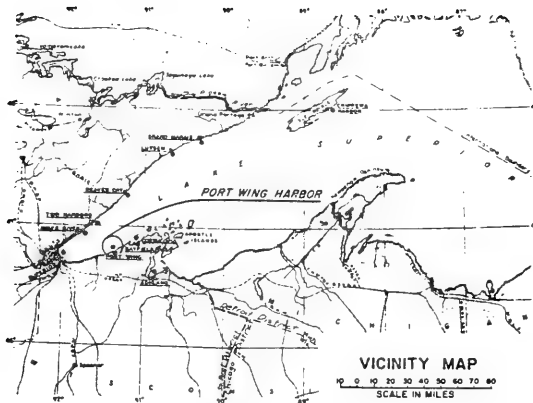


Figure 13. Port Wing Harbor, Wisconsin

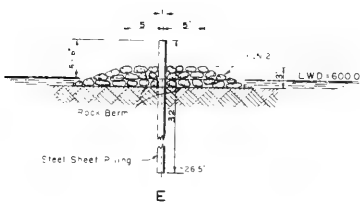
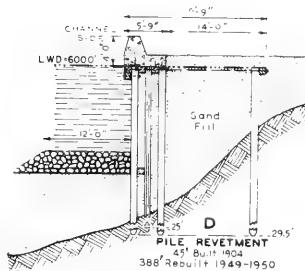
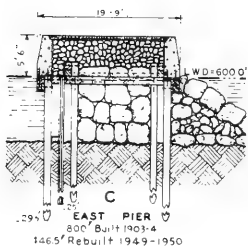
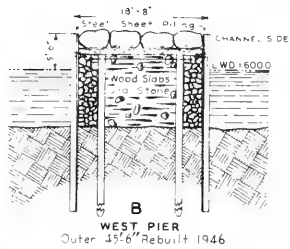
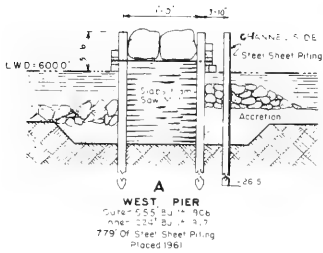


Figure 14. Typical structure cross sections,  
 Port Wing Harbor, Wisconsin

Table 6  
Cornucopia Harbor Piers  
Cornucopia, Wisconsin

<u>Date(s)</u>	<u>Construction and Rehabilitation History</u>
1957	<p>Construction of a 938-ft-long east pier and a 530-ft-long west pier was completed at the site (Figure 15). The shoreward 370 ft and 372 ft of the west and east piers, respectively (Figures 15 and 16, Section D), were constructed with woodpiling and filled with stone. Steel sheetpiling was installed also on the channel side at an el of +8 ft lwd. The remaining 160 ft of the west pier, and the next 286 ft of the east pier (Figures 15 and 16, Sections B and C) were constructed of woodpiling with sand and stone fill. Steel sheetpiling was installed on each side of the structure at a +8 ft el lwd. Stone was grouted in place to cap the structure. The west pier was 15 ft wide, and the east pier ranged from 17 to 45 ft in width. The next 100 ft of the east pier was constructed of steel sheetpiling with sand and rock fill (Figures 15 and 16, Section E). This structure was 24 ft wide with a crest el of +8 ft lwd. The outer 180 ft of the east pier was a cellular sheet-pile structure (Figures 15 and 16, Section F). The cells were filled with dredged sand or gravel and capped with 2 ft of rocks filled with grout. The diameter of the cells was 30.55 ft, and the crest el was +8 ft lwd. Rock berms were placed at the toe of the structure on both sides.</p>
1986	<p>No records of repair to the structure have been noted, and the piers presently are in good condition.</p>

LAKE SUPERIOR

SISKIWIT BAY

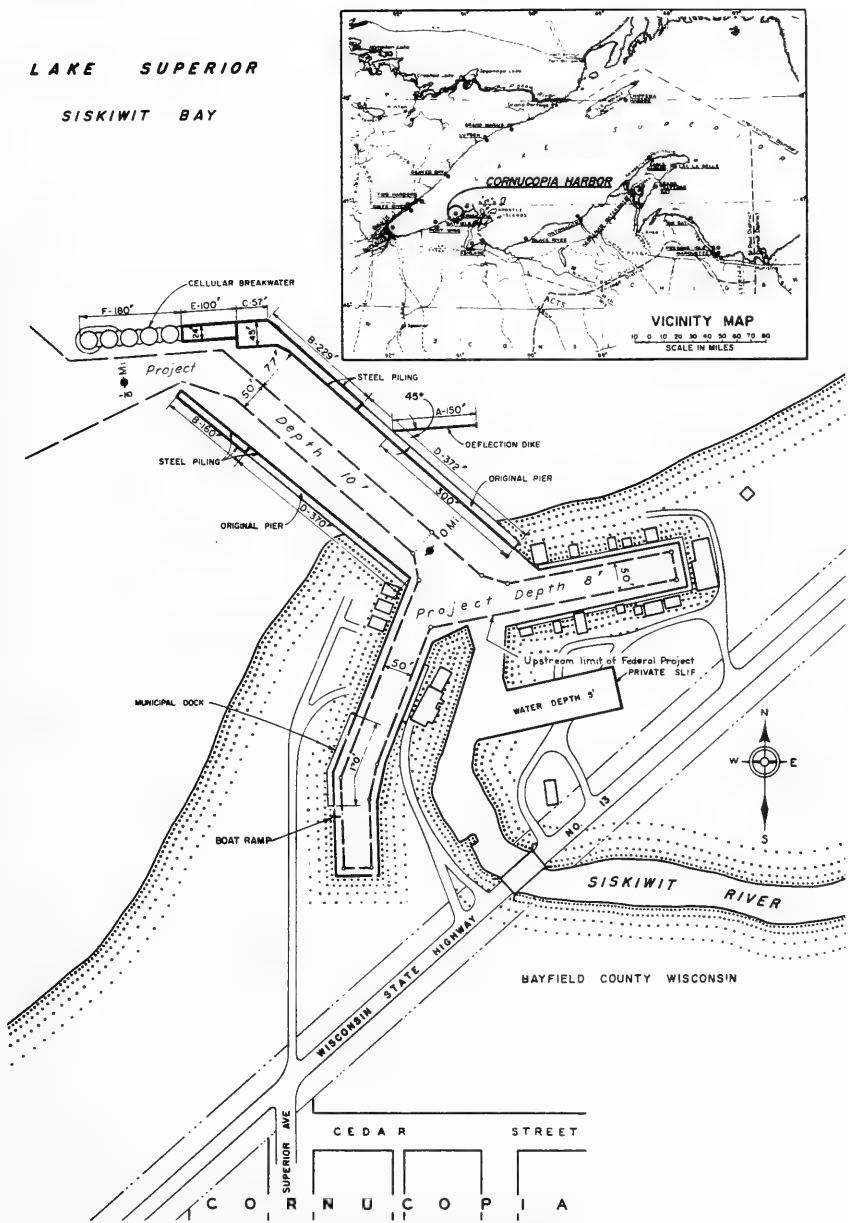


Figure 15. Cornucopia Harbor, Wisconsin

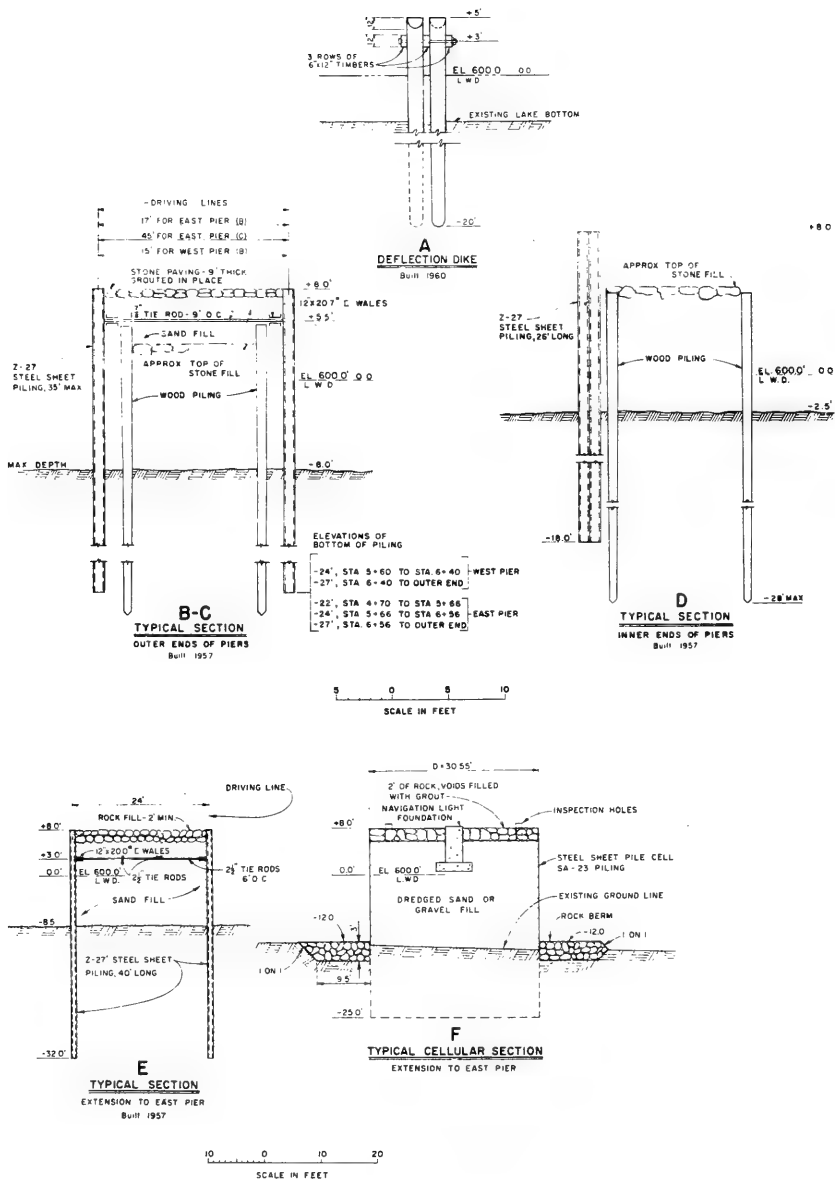


Figure 16. Typical structure cross sections, Cornucopia Harbor, Wisconsin

Table 7

Bayfield Harbor StructuresBayfield Harbor, Wisconsin

Date(s)	Construction and Rehabilitation History
1936	A 465-ft-long pier (Figure 17, Section A) was constructed by the State of Wisconsin. The pier was a rock-filled timber crib structure that was 24 ft wide and had a crest el of +4 ft lwd (Figure 18, Section A).
1941	A 200-ft-long city pier ell and a 459-ft-long city breakwater pier (Figure 17, Section B) were constructed by the State of Wisconsin. The structures had the same cross sections as the pier built in 1936.
1960	A 103-ft-long extension of the city pier ell and a 139-ft-long extension of the city breakwater pier were completed by the Corps. The extensions were of cellular sheet-pile construction. The cell diameters were 30.55 ft in width and had a +6 ft lwd crest el. They were sand filled with a grout-filled stone cap. Toe protection was provided on the lakeward side of the north extension only (Figures 17 and 18, Section C). The Corps also built a parapet wall totaling 843 ft in length on the existing piers. The crest el of the parapet was +6 ft lwd.
1986	The structures presently are in good condition.

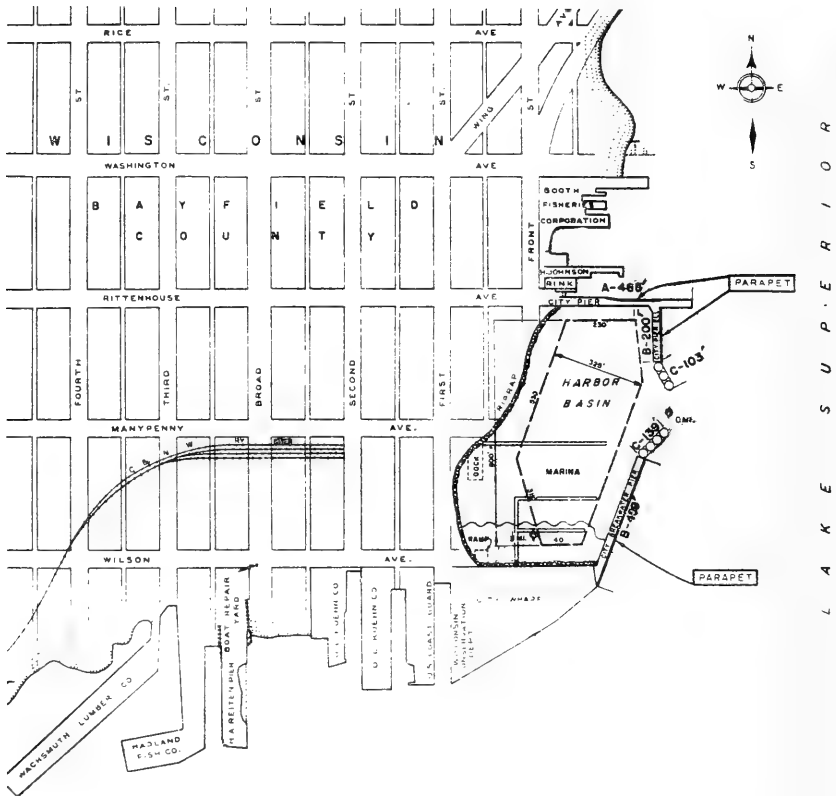
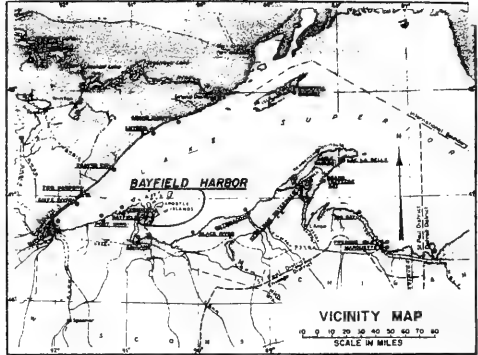
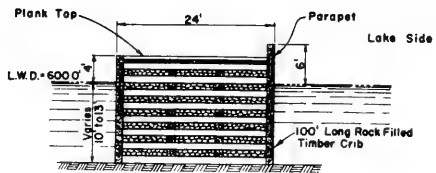


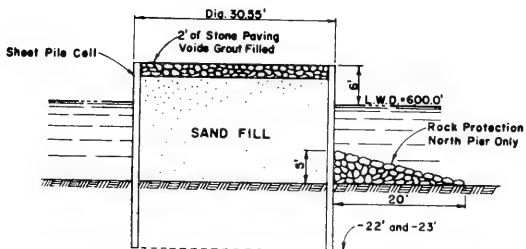
Figure 17. Bayfield Harbor, Wisconsin





**A and B**

- A. City pier 465' long built 1936 by W.P.A.  
184' of parapet added 1960
- B. City Breakwater and City Pier EII built 1941  
Superstructure rebuilt and parapet added 1960



**C**

Built 1960

Figure 18. Typical structure cross sections, Bayfield Harbor, Wisconsin

Table 8

La Pointe Harbor BreakwaterMadeline Island, Wisconsin

<u>Date(s)</u>	<u>Construction and Rehabilitation History</u>
1967	A 200-ft-long extension of an existing rock-filled timber crib breakwater was completed by the Corps (Figure 19). The existing structure was 37.3 ft wide with a crest el of +4 ft lwd. It was constructed by local interests (Figures 19 and 20, Section A). The initial 74 ft of the extension was built with steel sheetpiling that was sand filled and capped with stone (Figures 19 and 20, Section B). It was 25 ft wide with a crest el of +7 ft lwd on the lakeside and +4 ft lwd on the harbor side. The lakeward 126-ft length of extension was a cellular sheet-pile structure with cell diameters of 20.36 ft. They were sand filled and had stone caps (Figures 19 and 20, Section C). The crest el of the sheet pile was +7 ft lwd on the lakeside and ranged from +4 to +7 ft lwd on the harbor side. Riprap was placed along the toe of the cellular structure.
1986	No repairs to the structure have been noted, and it is presently in good condition.

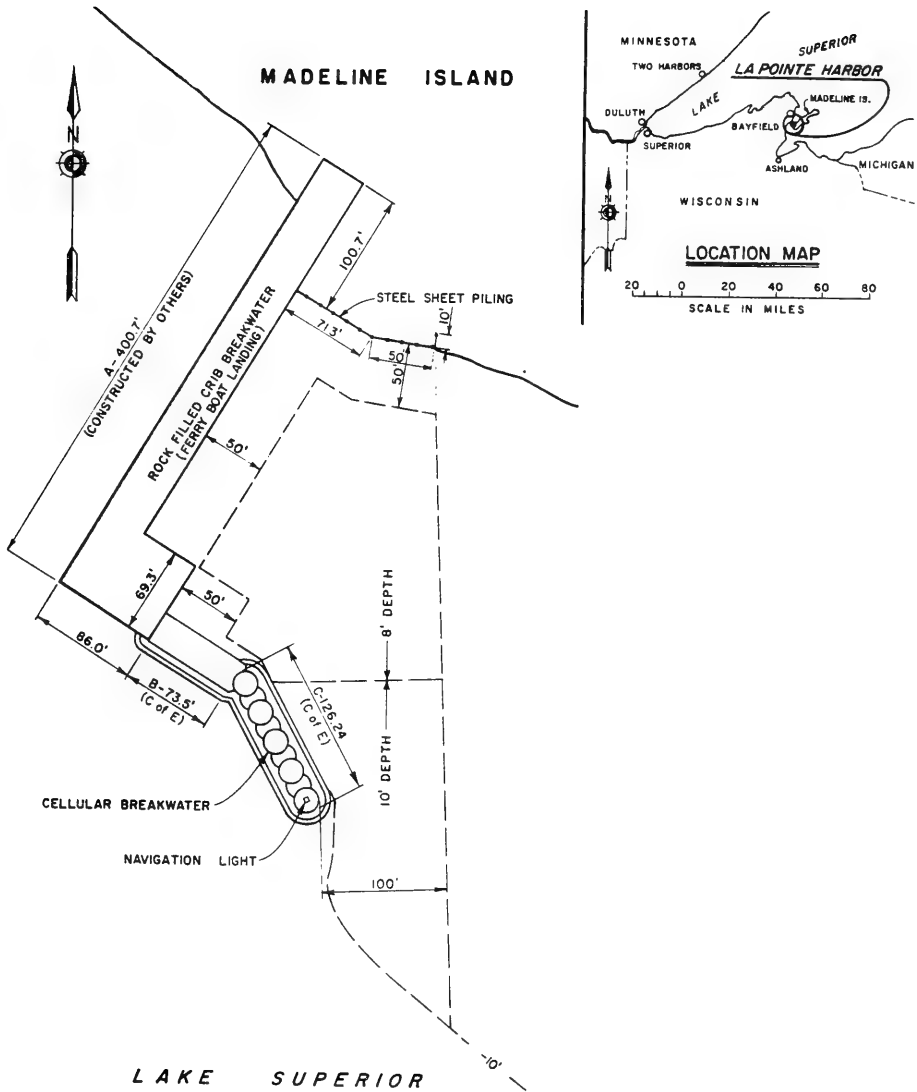
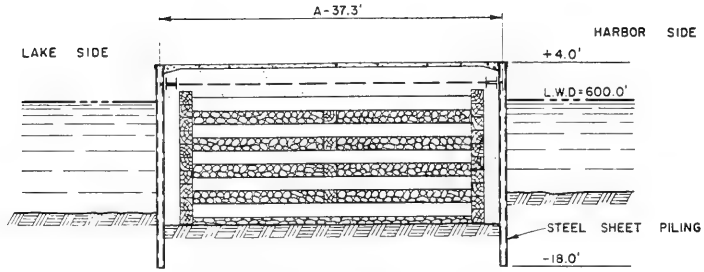
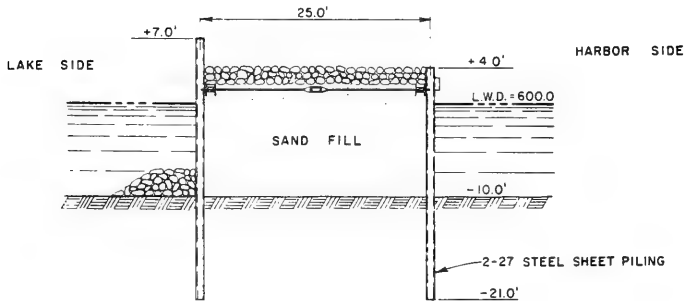


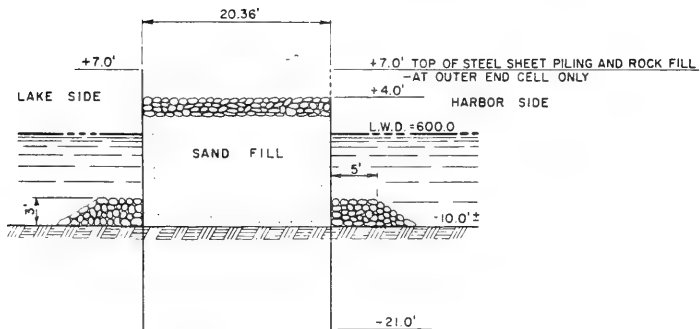
Figure 19. La Pointe Harbor, Wisconsin



**A**  
**BREAKWATER**  
 TIMBER CRIB 400.7'  
 (COMPLETED BY OTHERS)



**B**  
**BREAKWATER**  
 STEEL SHEET PILING 73.5'  
 (CORPS OF ENGINEERS)

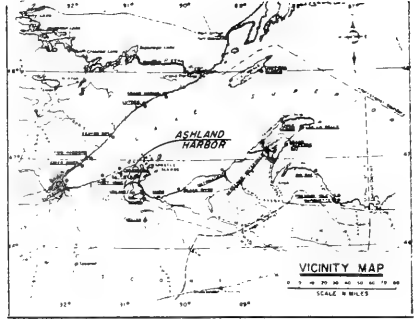


**C**  
**BREAKWATER**  
 CELLULAR 126.24'  
 (CORPS OF ENGINEERS)

Figure 20. Typical breakwater cross sections,  
 La Pointe, Wisconsin

Table 9  
Ashland Harbor Breakwater  
Ashland, Wisconsin

<u>Date(s)</u>	<u>Construction and Rehabilitation History</u>
1889- 1894	Construction of a 7,363-ft-long timber crib breakwater progressed at the site (Figures 21 and 22, Section C) during this time. The structure was filled with timber slabs and capped with stone. It had a crest width ranging from 20 to 28 ft and was installed at el +7 ft lwd.
1908- 1910	Stone reinforcement was installed on both sides of the structure (Figure 22, Section C) on a slope of 1V:1.5H.
1911	A timber crib pierhead was constructed. The structure was stone and timber filled, 32 ft wide, and 48 ft long. Riprap toe protection was included (Figures 21 and 22, Section A).
1912- 1913	A 589-ft-long rubble-mound breakwater was built during this period. The structure connected the pierhead to the original breakwater (Figure 21, Section B). It had a +7 ft lwd crest el with a 10-ft-width (Figure 22, Section B). Side slopes were approximately 1V:1H.
1913- 1914	A concrete and stone cap (superstructure) was installed on the pierhead. The el of the structure was now +6.75 ft lwd.
1986	Only routine maintenance has been performed, and the structure presently is in fair condition.



L A K E S U P E R I O R  
C H E Q U A M E G O N B A Y

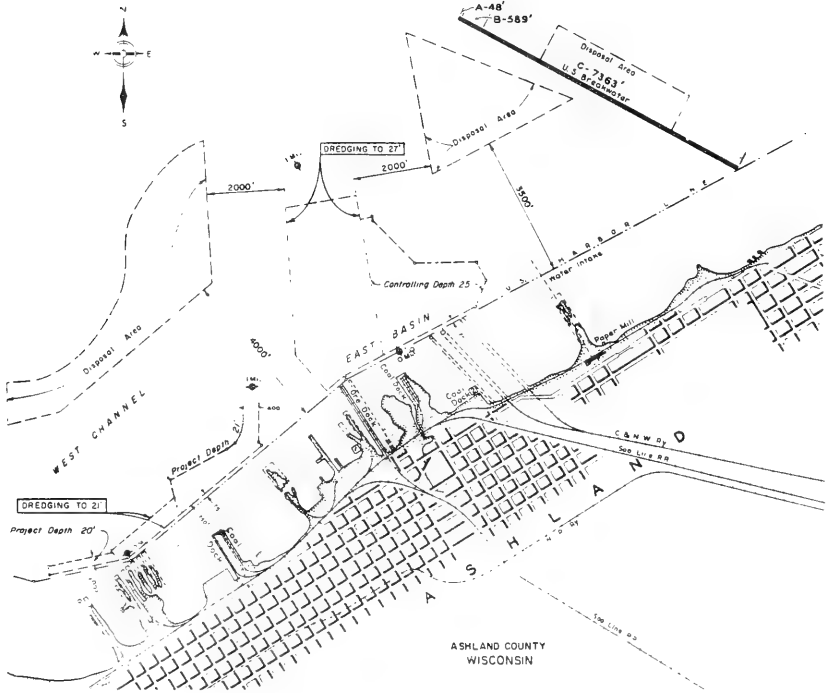
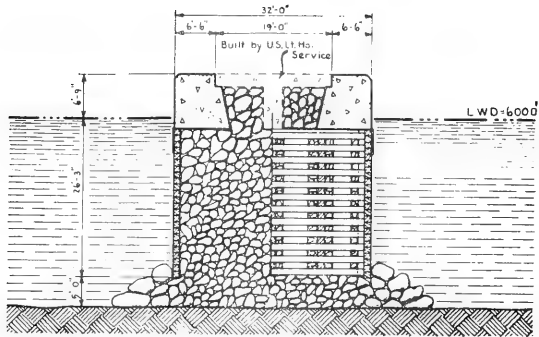
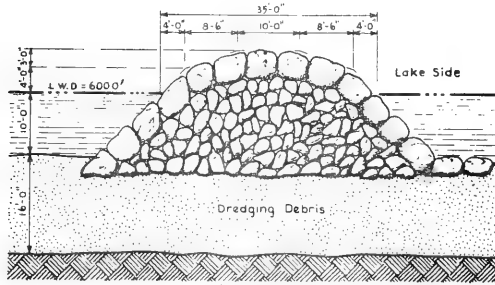


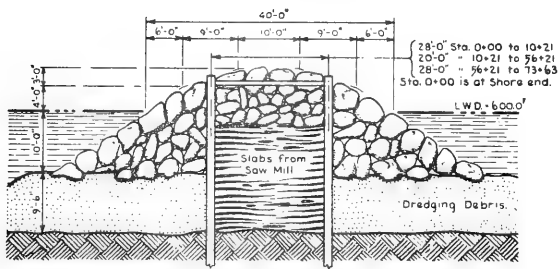
Figure 21. Ashland Harbor, Wisconsin



**PIERHEAD**  
Outer 48' Built { Substructure 1911  
Superstructure 1913-14  
**A**



589' Adjacent to Pierhead  
Built 1912-13  
**B**



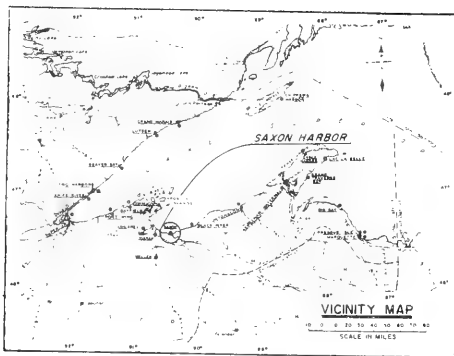
Inner 7363' Built { Timber Structure 1889-94  
Rubble Reinforcement 1908-10  
**BREAKWATER**  
**C**

Figure 22. Typical structure cross sections,  
Ashland Harbor, Wisconsin

Table 10  
Saxon Harbor Breakwaters  
Saxon, Wisconsin

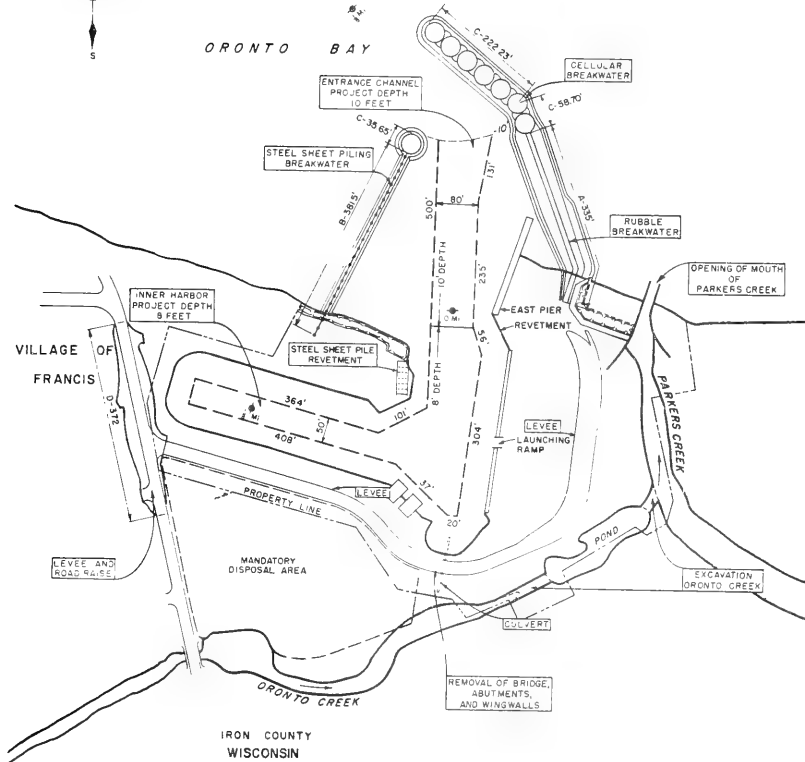
Date(s)	Construction and Rehabilitation History
1965	Construction of a 417-ft-long west breakwater and a 616-ft-long east breakwater was completed at the site (Figure 23). The shoreward 335 ft of the east breakwater was of rubble-mound construction. The crest el was +8 ft lwd with an 8-ft width, and side slopes were 1V:1.5H (Figure 24, Section A). Armor stone was approximately 6 ft thick. The shoreward 381.5 ft of the west breakwater was constructed of steel sheetpiling with rock toe protection (Figure 24, Section B). The crest el was +8 ft lwd. The lakeward ends of both structures were cellular sheet pile (Figures 23 and 24, Section C). Cells with diameters of 35.65 ft were used. They were filled with excavation fill and capped with stone (voids filled with concrete). The crest el of the cells was +8 ft lwd, and toe protection was included.
1983	An inspection made of the site indicated minor cracking of the cap of the innermost east breakwater cell. The cap of the outermost east breakwater cell was also noted cracking with a void in the center of the cap. In addition, the cap had settled as much as 8 in. in some areas.
1986	The structures have undergone only routine maintenance and presently are in good condition.





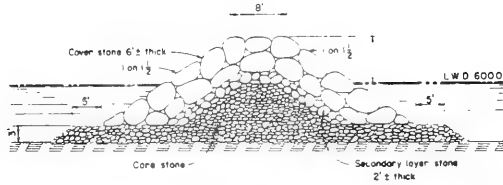
LAKE SUPERIOR

ORONTO BAY

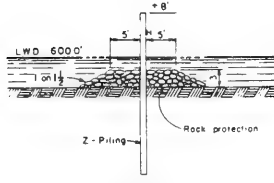


IRON COUNTY  
WISCONSIN

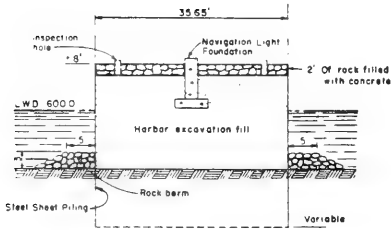
Figure 23. Saxon Harbor, Wisconsin



A  
335 East Breakwater



B  
381 1/2 West Breakwater



C  
39 65' West Breakwater  
280 93' East Breakwater

Figure 24. Typical breakwater cross sections, Saxon Harbor, Wisconsin

Table 11  
Black River Harbor Breakwaters  
Gogebic County, Michigan

<u>Date(s)</u>	<u>Construction and Rehabilitation History</u>
1957	The construction of an 825-ft-long east breakwater and a 555-ft-long west breakwater was completed at the site (Figure 25). The breakwaters were of rubble-mound construction (Figure 26) with crest elevations of +7 ft lwd and crest widths of 8 ft. Side slopes were 1V:1.5H, and 3-ton minimum armor stone was used.
1983	An inspection made of the structures revealed that both breakwaters were in good condition with the exception of several areas on each structure that needed additional core and cover stone.
1986	Since construction, the breakwaters have been repaired during routine maintenance operations. They presently are in good condition. An aerial view of Black River Harbor breakwaters is shown in Figure 27.

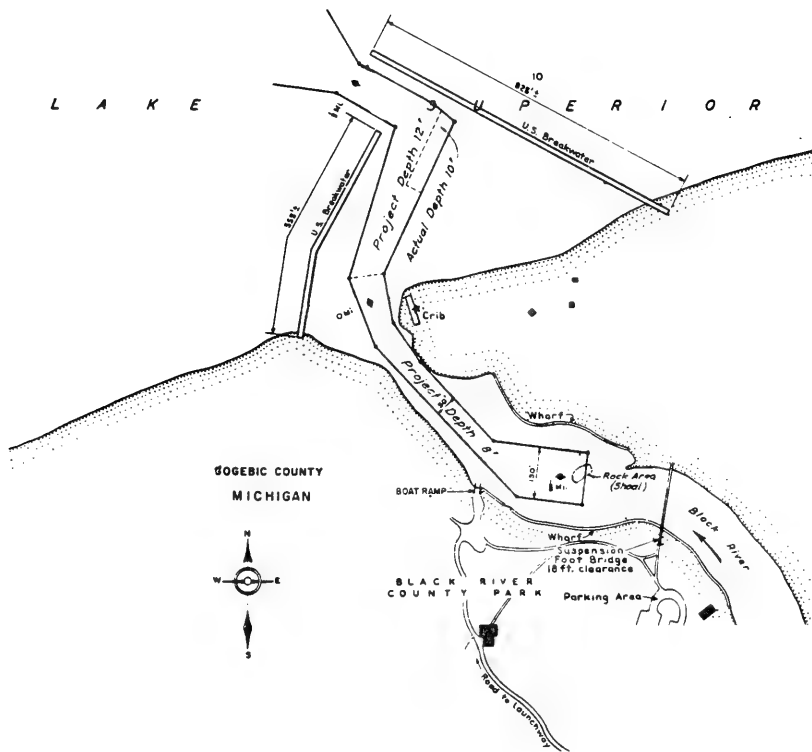
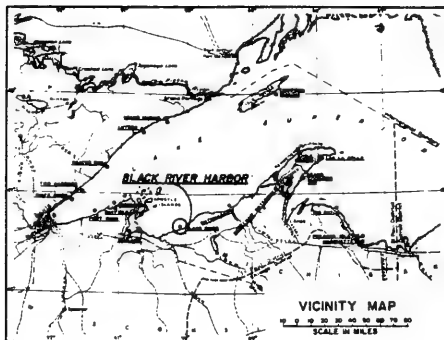
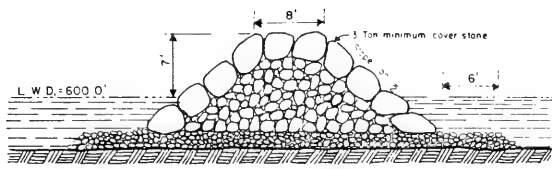
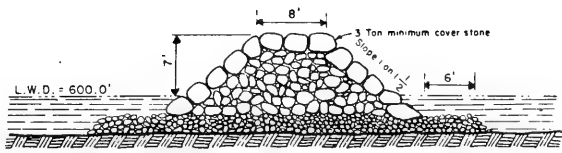


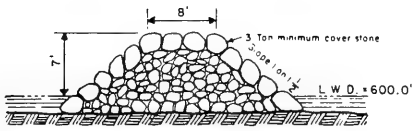
Figure 25. Black River Harbor, Michigan



Lakeward End to -5 Ft. Contour



-5 Ft. Contour to +2 Ft. Contour



+2 Ft. Contour to Landward End

**RUBBLE MOUND - BUILT 1957  
EAST AND WEST BREAKWATERS**

Total Lengths { East Breakwater - 825 Ft.  $\frac{1}{2}$   
West Breakwater - 555 Ft.  $\frac{1}{2}$

Figure 26. Typical breakwater cross sections, Black River Harbor, Michigan



Figure 27. Aerial view of Black River Harbor, Michigan

Table 12  
Ontonagon Harbor Piers  
Ontonagon, Michigan

<u>Date(s)</u>	<u>Construction and Rehabilitation History</u>
1868- 1872	Construction of the inner 1,069 ft of the west pier (Figures 28 and 29, Section E) occurred during this time. This structure consisted of woodpiling filled with stone. The pier width ranged from 8.5 to 11 ft.
1868- 1879	The outer 1,515 ft of the east pier (Figures 28 and 29, Section A) was built during this period. This was a rock-filled timber crib structure. The pier was 20 ft wide and had stone toe protection at its base.
1875- 1890	Construction of 1,398 ft of the west pier (Figures 28 and 29, Section A) progressed. The pier had the same cross section as the pier built during 1868-79.
1881- 1882	Construction of an additional 255 ft of the east pier (Figures 28 and 29, Section B) was completed. This was a 20-ft-wide stone-filled timber crib structure with stone toe protection.
1882- 1888	The inner 545 ft of the east pier (Figures 28 and 29, Section C) was built. This pier also was a stone-filled timber crib structure with a 20-ft crest width.
1920- 1935	A stone superstructure was built on 1,515 and 1,398 ft of the east and west piers, respectively (Figure 29, Section A). The el of these piers was +5 ft lwd.
1933	A concrete cap (superstructure) was constructed on the inner 1,069 ft of the west pier (Figure 29, Section E). The el of the channel side of the pier was +4 ft lwd.
1935- 1936	A stone and concrete cap (superstructure) was installed on 800 ft of the east pier (Figure 29, Sections B and C). The shoreward 545 ft of structure had a crest el of +5 ft lwd (Section C), while the remaining pier had an el of +6 ft lwd (Section B).
1947	The 96-ft-long west pierhead was rebuilt with steel sheetpiling that was stone filled. It was capped with 5-ton minimum cover stone. The pierhead was 22 ft wide with a crest el of +6 ft lwd. Riprap was installed to provide toe protection. It is not clear when the pierhead was originally constructed.
1983	A structural inspection of the piers was made. A void up to 20 ft wide was observed on the west pier, and sand was being lost through the cribbing under the superstructure. Additional stone was required

(Continued)

Table 12 (Concluded)

Date(s)	Construction and Rehabilitation History
	<p>at various locations on both piers, and it was noted that the concrete superstructure had spalled in areas. In the summer of this year, core and cover stone were placed where necessary to repair the structures.</p>
1986	<p>The piers presently are in fair condition. An aerial view of Ontonagon Harbor piers is shown in Figure 30.</p>



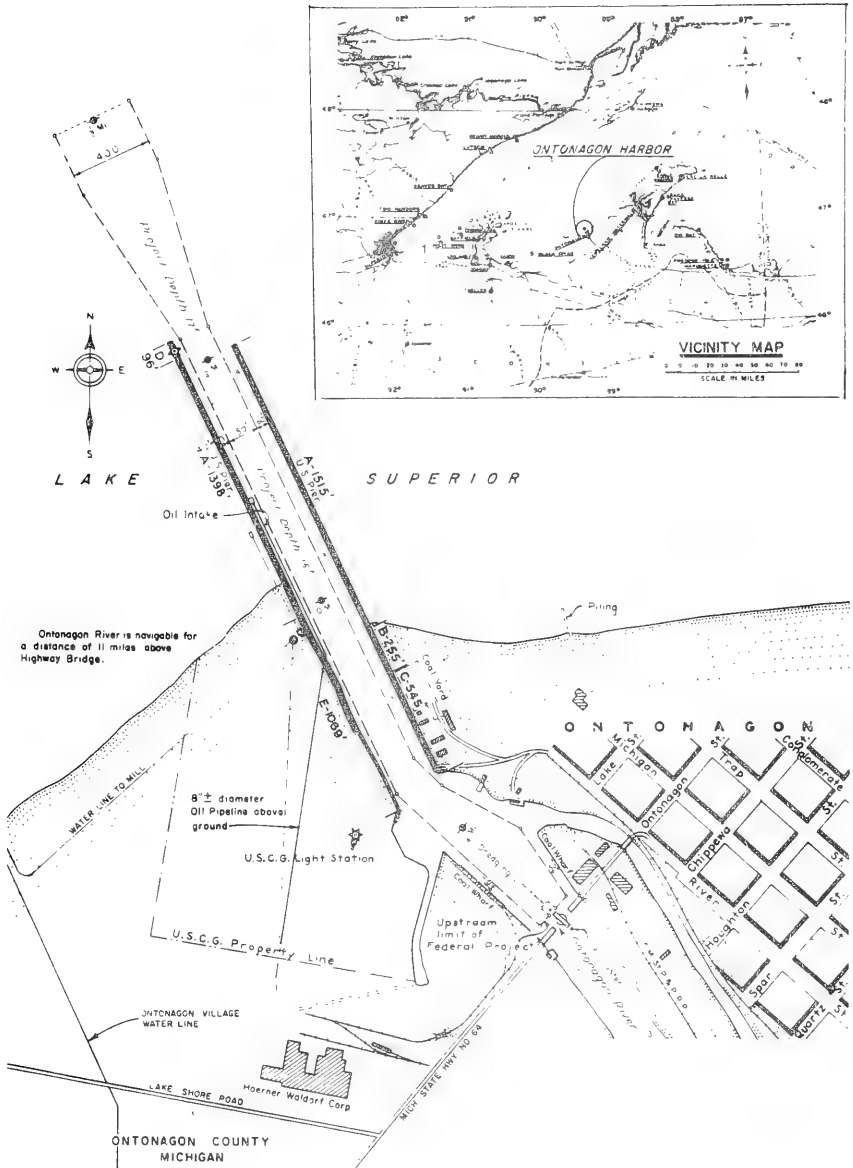


Figure 28. Ontonagon Harbor, Michigan

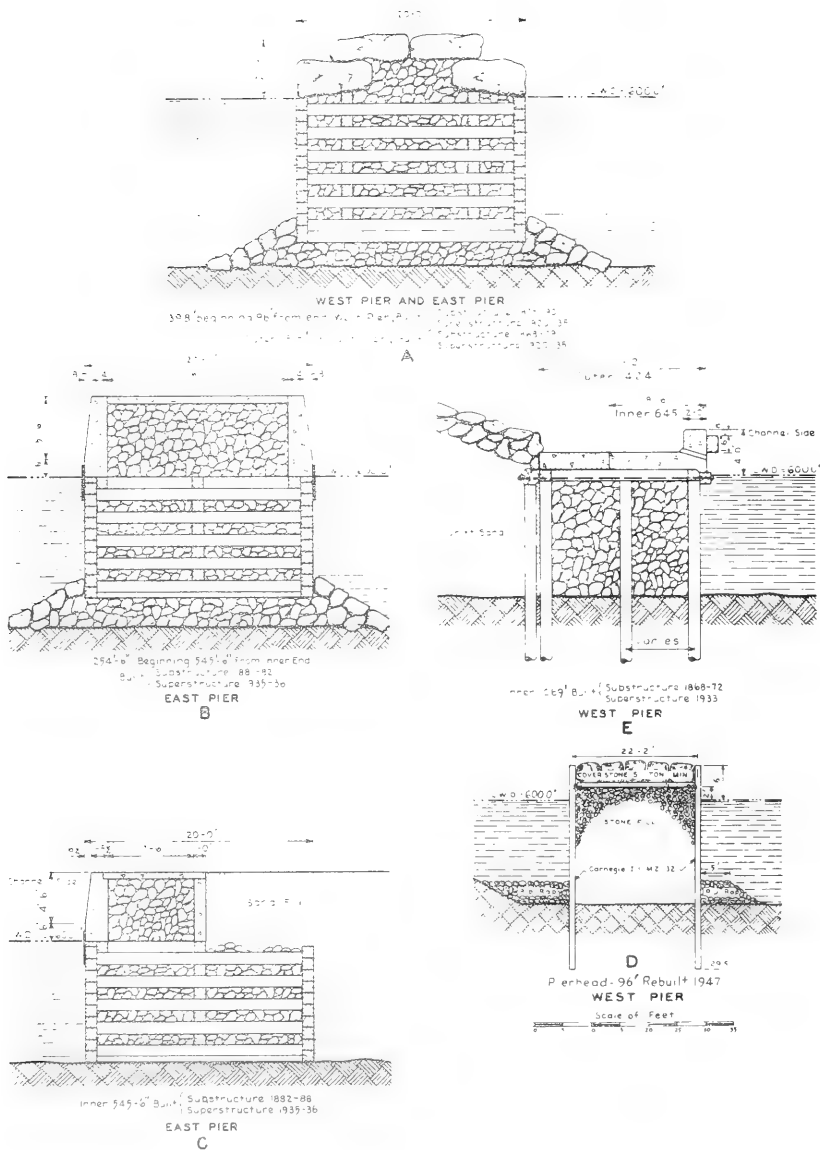


Figure 29. Typical pier cross sections, Ontonagon Harbor, Michigan



Figure 30. Aerial view of Ontonagon Harbor, Michigan

Table 13

Keweenaw Waterway StructuresKeweenaw Waterway, Michigan

<u>Date(s)</u>	<u>Construction and Rehabilitation History</u>
<u>North (Upper) Entry</u>	
1898- 1902	A 2,385-ft-long east breakwater and a 2,645-ft-long west breakwater were constructed at the north entrance during this time (Figure 31, Sections C and D). These structures were stone-filled timber crib breakwaters. The shore wings were 20 ft wide, and the main breakwaters were 30 ft wide.
1917- 1931	The main breakwaters (Figures 31 and 32, Section C) were capped with 5-ton stone. Fifteen-ton stone was placed on the channel side of the structure for stability of the cap. The el of the structure was +8 ft lwd. Rubble was placed on the lakeward side of the structure on a 1-V:1.5-H slope and capped with 10-ton stone.
1933	The inner wings of the breakwaters (Figures 31 and 32, Section D) were capped with a stone fill and concrete. The el of the structures ranged from +5 to +7 ft lwd. Rubble toe protection also was installed.
1948- 1949	Construction of the breakwater pierheads (Figures 31 and 32, Sections A and B) progressed during this period. The 50-ft-long east pierhead was built with steel sheet piles and sand, and the outer cover of the entire structure was built with concrete. The crest el of the structure was +18 ft lwd. The west pierhead was 50 ft long and constructed of concrete and steel sheet piles with a sand fill. The el of the structure was +10 ft lwd.
1986	The breakwaters at the Upper Entry have undergone routine maintenance and presently are in fair condition. Figure 33 is an aerial view of the upper entrance to Keweenaw Waterway.
<u>South (Lower) Entry</u>	
1860	Construction on the inner 950 ft of the breakwater was completed by private interests (Figure 34, Section I-L). This structure was a stone-filled timber crib breakwater. The width of the shoreward 325 ft of breakwater was 13 ft, and the remaining structure was 30 ft wide to a point 912 ft from its origin. At this point, the structure width changed to 24 ft.
1897- 1900	The outer 2,764 ft of the breakwater was built by the United States during this period (Figure 34, Sections L-N). The breakwater was a stone-filled timber crib structure with a 24-ft width, except for the lakeward 100 ft which was 30 ft wide.

(Continued)

Table 13 (Concluded)

Date(s)	Construction and Rehabilitation History
	<u>South (Lower) Entry</u>
1920	The outer 50 ft of the breakwater was capped with concrete (Figures 34 and 35, Section N). The crest el of the cap was +5.5 ft lwd, and it was 32 ft in width.
1927	The shoreward 912 ft of the structure was capped with stone and concrete (Figures 34 and 35, Sections I-K). The crest of the shoreward 325 ft of breakwater was built at an el of +4.0 ft lwd with the remaining 587 ft installed at an el of +4.5 ft lwd.
1928- 1930	During this period a 2,702-ft-long section of the breakwater was capped with stone and concrete (Figures 34 and 35, Section L). A crest el of +6 ft lwd was constructed.
1930	The superstructure of the 50-ft-long pierhead was completed (Figures 34 and 35, Section M). Concrete and stone were used for construction with a crest height of +6 ft lwd installed.
1983	An inspection of the Lower Entry breakwater indicated the structure was stable and generally in good condition. Extreme spalling of the concrete had taken place in some areas, however, and some areas of the breakwater were in need of additional stone fill.
1986	The breakwater at the Lower Entry presently is in fair to good condition.

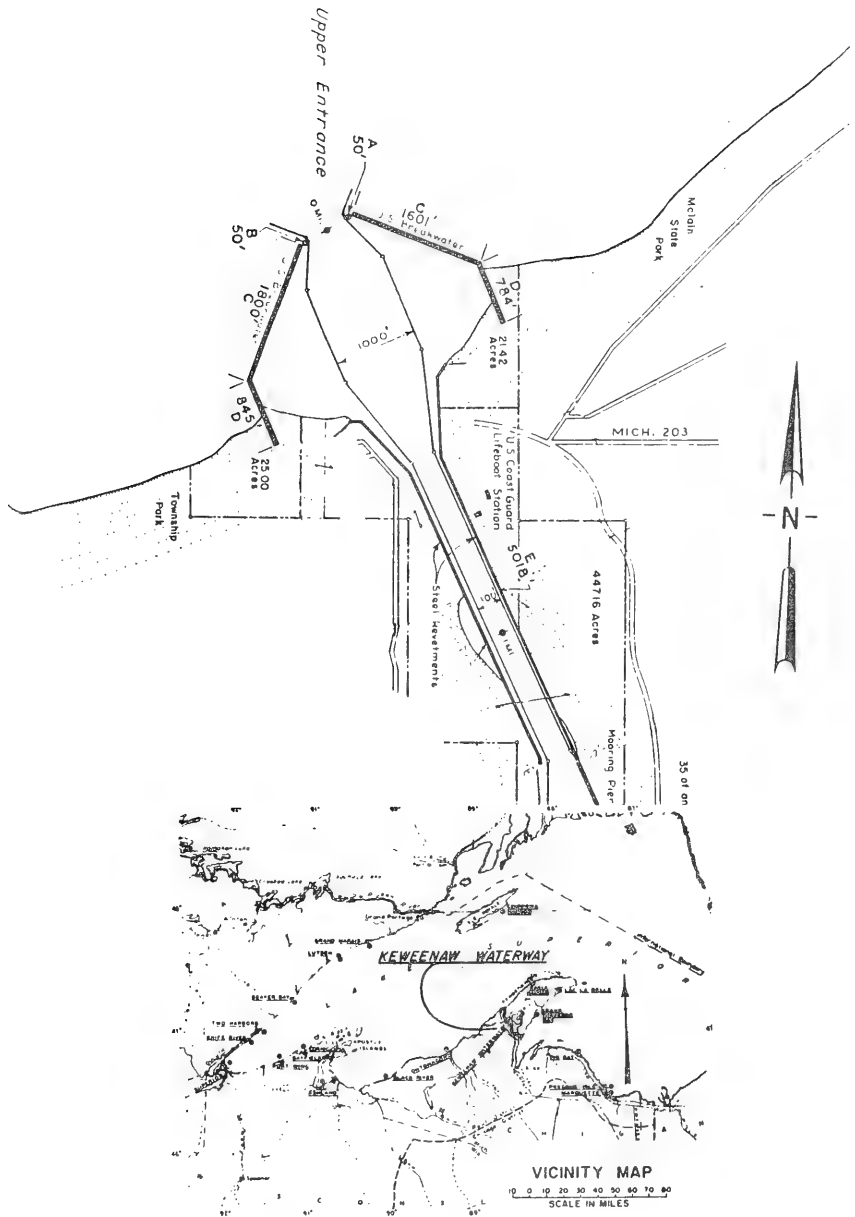
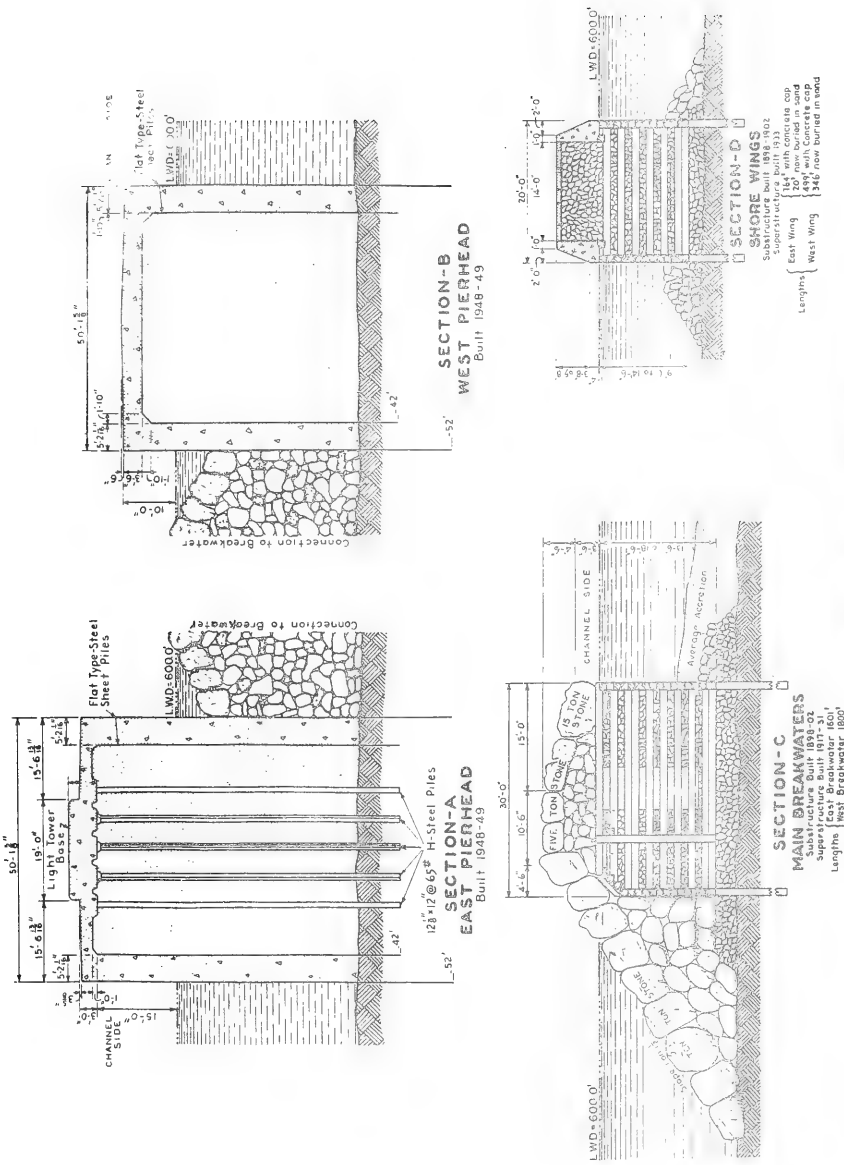


Figure 31. Upper entrance, Keweenaw Waterway, Michigan



**BREAKWATERS AT UPPER ENTRANCE**

Figure 32. Upper entrance typical structure cross sections, Keweenaw Waterway, Michigan



Figure 33. Aerial view of upper entrance to Keweenaw Waterway, Michigan





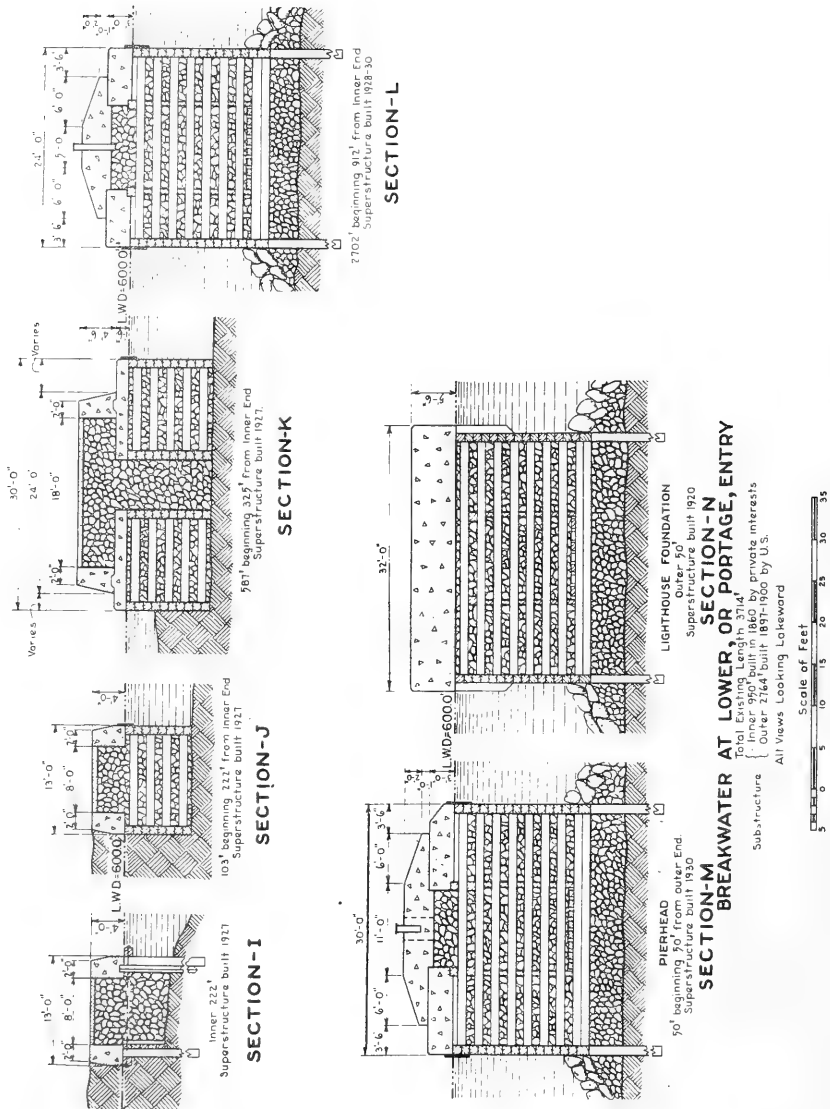


Figure 35. Lower entrance typical breakwater cross sections, Keweenaw Waterway, Michigan

Table 14

Lac La Belle Harbor BreakwatersKeweenaw County, Michigan

<u>Date(s)</u>	<u>Construction and Rehabilitation History</u>
1959	Construction of two breakwaters was completed at the site (Figure 36). Three consisted of a 490-ft-long north breakwater and a 689-ft-long south breakwater. The north breakwater consisted of a 458-ft steel Z-piling section and a 32-ft cellular steel sheet-pile head. The south breakwater had a 470.5-ft steel Z-piling section with cellular steel sheet piles on the lakeward end cumulating over 218 ft in length (Figure 36). The Z-piling and the cellular structures were both built to an el of +8 ft lwd. The cellular sheet piles were 32 ft in diameter and were sand filled with a 2-ft rock cap (Figure 37). Rock toe protection was provided on the lakeside of the outer cells on the south breakwater.
1983	An inspection of the structures revealed a tipped section toward the channel on the south breakwater about 50 ft shoreward of the cells. Subsequently, the tipped section was straightened, and stone was added on the channel side to prevent scour.
1986	The breakwaters presently are in good condition. An aerial view of Lac La Belle Harbor breakwaters is shown in Figure 38.

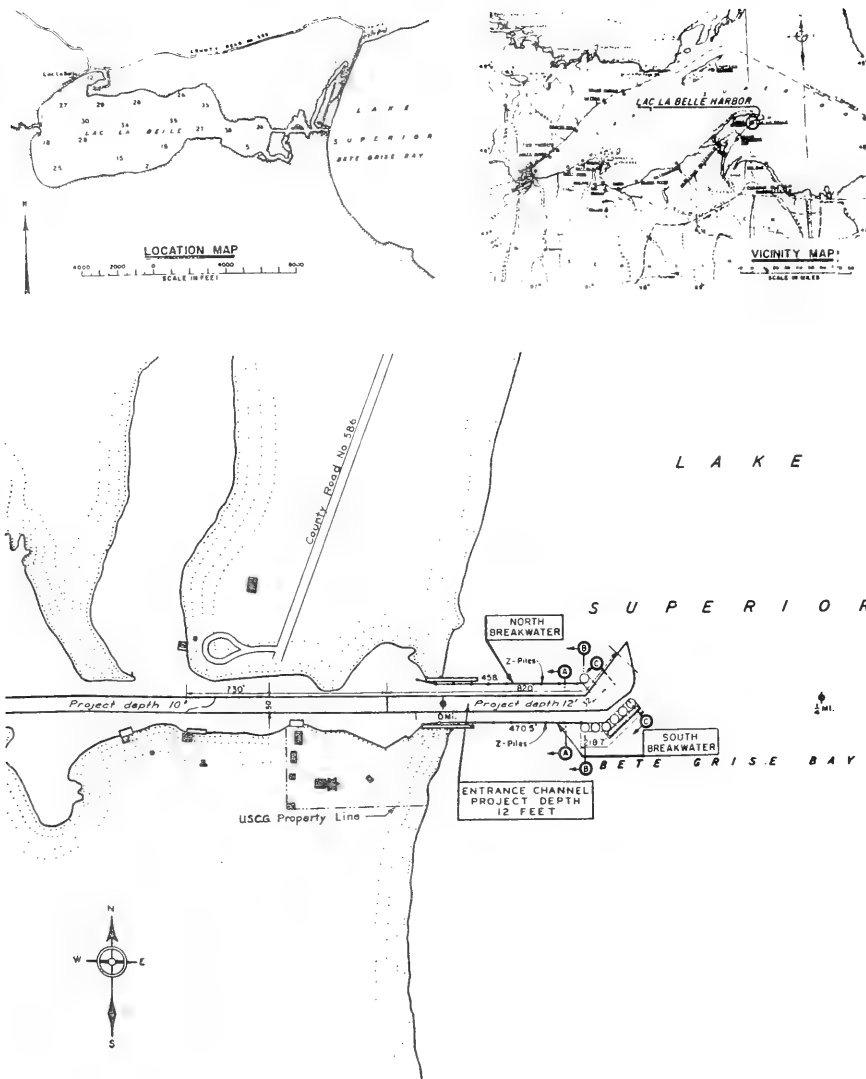
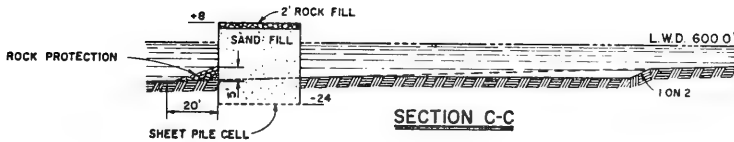
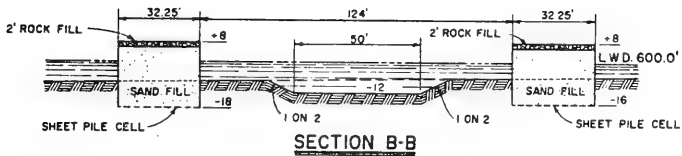
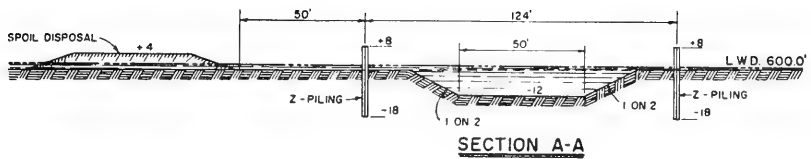


Figure 36. Lac La Belle Harbor, Michigan



NORTH Z-PILING BREAKWATER - 458.5'  
 SOUTH Z-PILING BREAKWATER - 470.5'  
 SOUTH CELL BREAKWATER - 218.7'

BUILT 1959

Figure 37. Typical structure cross sections,  
 Lac La Belle Harbor, Michigan



Figure 38. Aerial view of Lac La Belle Harbor, Michigan

Table 15  
Grand Traverse Bay Harbor Structures  
Grand Traverse Bay, Michigan

<u>Date(s)</u>	<u>Construction and Rehabilitation History</u>
1949- 1951	Construction of two piers at the site (Figure 39) progressed during this time. The north pier was 707 ft long, and the south pier was 567 ft long. The shoreward portions of the piers (Figures 39 and 40, Sections D and E) were built with steel sheet pile at an el of +6.5 ft lwd. They were backfilled with sand except at the top where a rock surface was installed. The 111-ft-long section of the north pier at the water's edge (Figures 39 and 40, Section C) was a sand-filled sheet-pile structure. It was 12 ft wide with an el of +8 ft lwd. The structure was capped with 2-ton (minimum) stone and 3-ton (minimum) stone placed on the lakeside to an el of approximately +4.5 ft lwd. A 307-ft-long section of the north pier, and the lake-ward portion of the south pier (Figures 39 and 40, Section B) were built with steel sheetpiling. The structure was sand filled with a concrete cap installed at an el of +6 ft lwd. The pier was 11.5 ft wide, and stone toe protection was included. The outer end of the north pier (Figures 39 and 40, Section A) was of similar construction except it was capped with 2-ton (minimum) stone at an el of +8 ft lwd and was 14.5 ft wide.
1964	Construction of a 164-ft-long north pier extension was completed (Figures 39 and 40, Section F). Cellular steel sheet piles with diameters of 37.3 ft were used. These cells were sand filled with 2-ft-thick rock (filled with grout) caps. The el of the cellular structures was +8 ft lwd, and stone toe protection was installed on the lakeward side.
1975	A 180-ft-long cellular sheet-pile north breakwater extension was completed (Figure 39).
1979	An inspection of the piers indicated that repairs were needed on the cap of the north pier at the intersection of the cell and Section A. Additional repairs were needed on the outer three cell caps.
1981	The north pier caps, identified in need of repair in 1979, were repaired.
1983	An inspection of the structures revealed that the cap on the south pier had settled as much as 6 in. in some areas. The outer cell of the north pier also had settled (up to 14 in.) and had several large cracks. Additional riprap stone also was required at Section C. Repairs to the structures were subsequently made.
1986	The piers presently are in good condition. An aerial view of Grand Traverse Bay Harbor structures is shown in Figure 41.

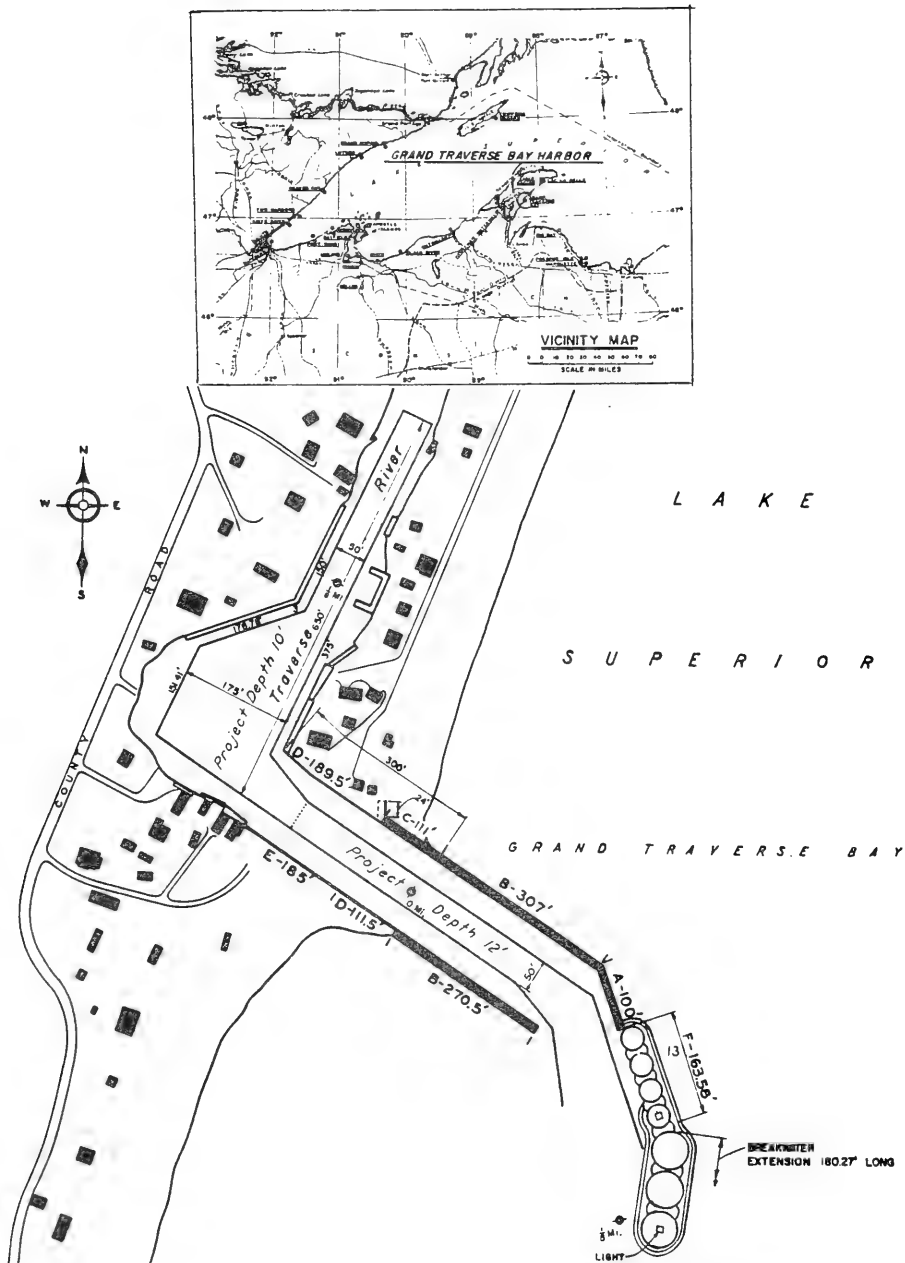


Figure 39. Grand Traverse Bay Harbor, Michigan



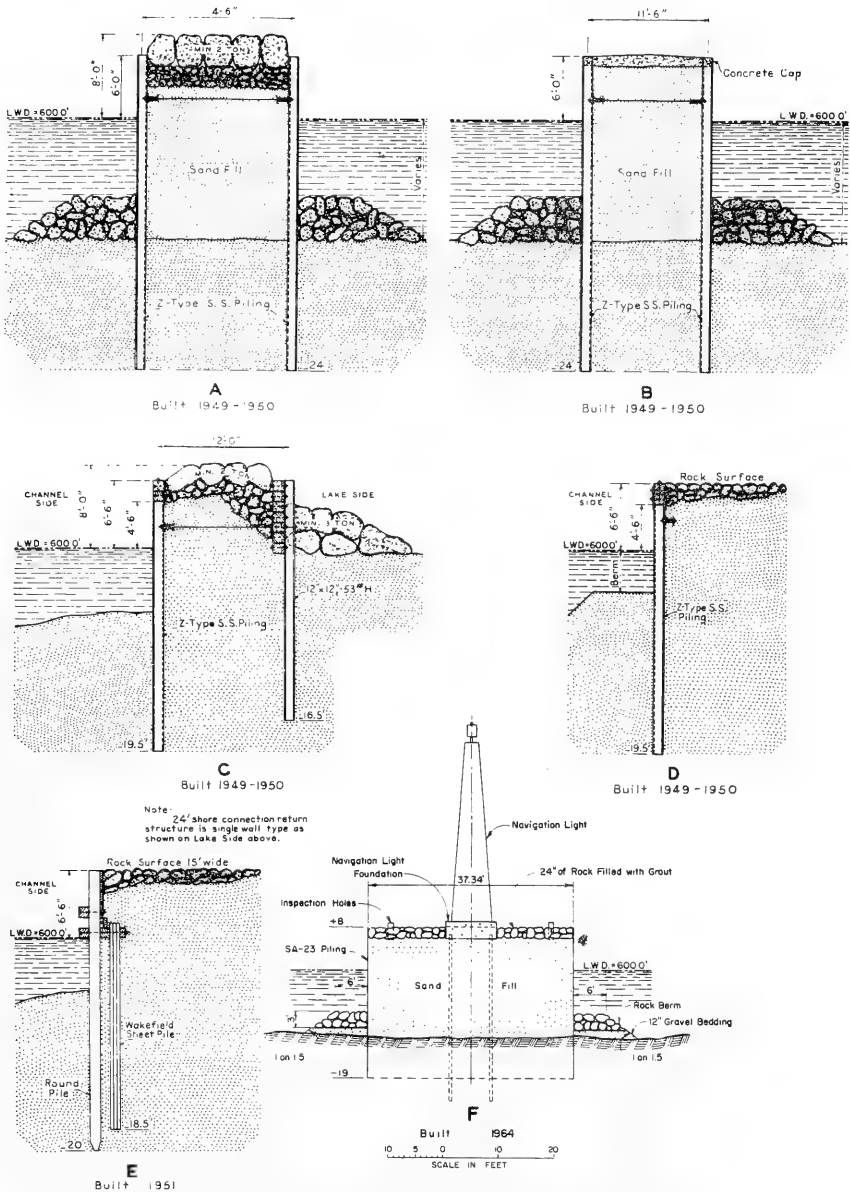


Figure 40. Typical structure cross section, Grand Traverse Bay Harbor, Michigan



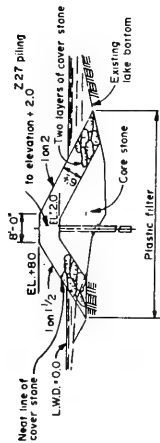
Figure 41. Aerial view of Grand Traverse Bay Harbor, Michigan

Table 16

Big Bay Harbor BreakwatersBig Bay, Michigan

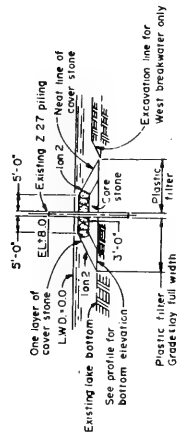
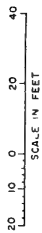
<u>Date(s)</u>	<u>Construction and Rehabilitation History</u>
1960	Construction of a 471-ft-long east breakwater and a 787-ft-long west breakwater was completed at the site (Figure 42). The shoreward 269-ft-long portion of the east breakwater was rubble-mound (Figures 42 and 43, Section A). It had an 8-ft crest width and a +8-ft lwd crest el. Slopes on the lakeside were 1V:2H, and on the harbor side they were 1V:1.5H. The structure was built around steel sheet-piling which had an el of +2 ft lwd. From this point lakeward a steel sheet-pile structure extended an additional 170 ft (Figures 42 and 43, Section B). The shoreward 547 ft of the west breakwater utilized the same structure. The sheetpiling had a crest el of +8 ft lwd with stone toe protection on each side. The head of the east breakwater consisted of a cellular sheet pile (32 ft in diameter), and the lakeward 240 ft of the west breakwater was constructed of 36-ft-diameter cellular sheetpile (Figures 42 and 43, Section C). These cells were filled with sand and capped with 2 ft of grout-filled rock. Rubble toe protection was included also.
1969	The east breakwater was rehabilitated.
1979	An inspection of the harbor structures indicated that additional rip-rap was needed on both sides of the west breakwater (Figure 43, Section B). The stone was eventually placed.
1986	The breakwaters presently are in good condition. An aerial view of Big Bay Harbor breakwaters is shown in Figure 44.





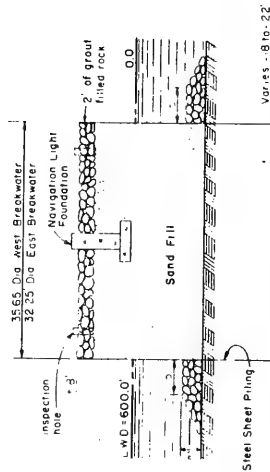
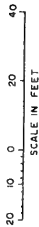
**SECTION A**

269' East Breakwater



**SECTION B**

547' West Breakwater  
170' East Breakwater



**C**

240 West Breakwater  
32 East Breakwater

Built 1960

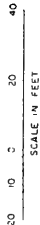


Figure 43. Typical breakwater cross sections, Big Bay Harbor, Michigan

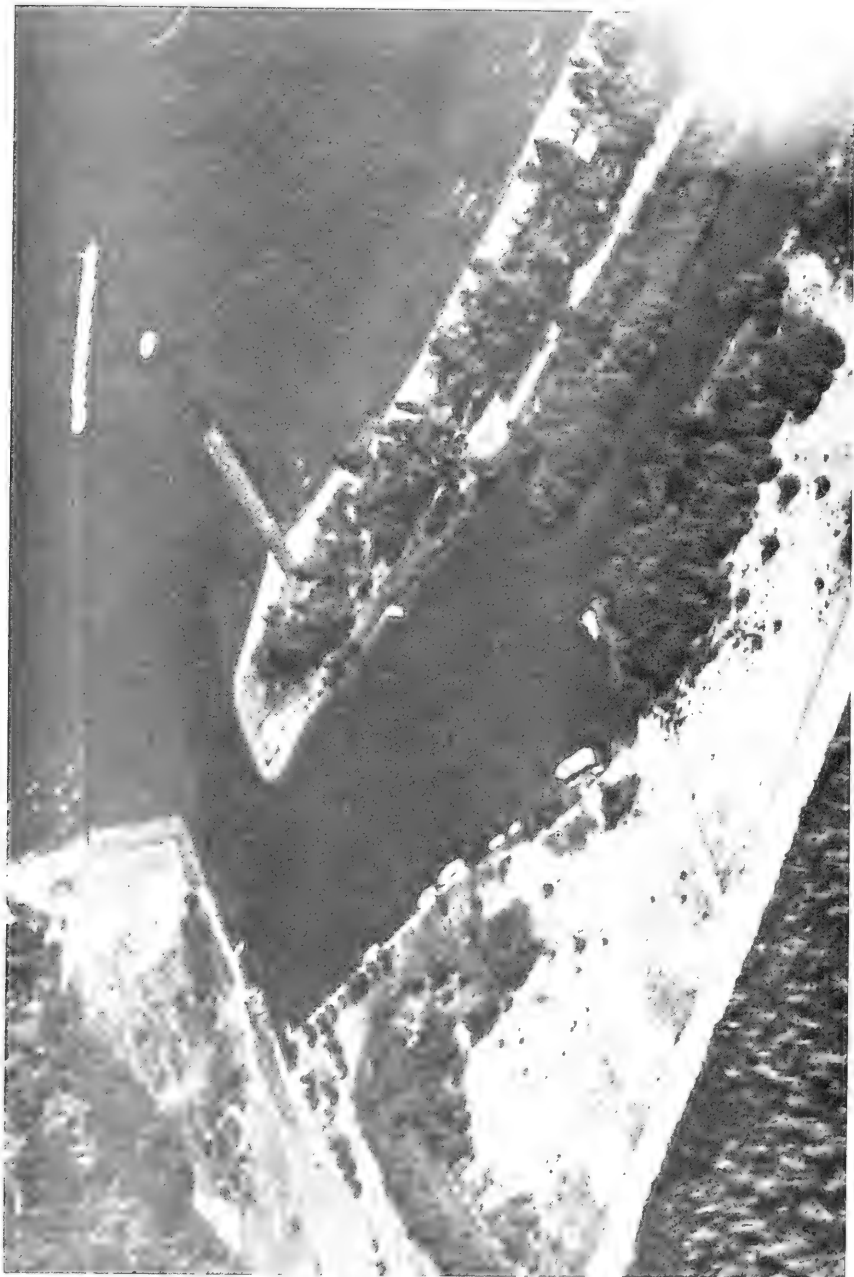


Figure 44. Aerial view of Big Bay Harbor, Michigan

Table 17

Presque Isle Harbor BreakwaterPresque Isle, Michigan

Date(s)	Construction and Rehabilitation History
1897- 1901	Construction of a 1,053-ft-long breakwater was performed during this period (Figures 45 and 46, Section B). The structure was a 24-ft-wide stone-filled timber crib breakwater with riprap toe protection.
1903	A 163-ft-long stone-filled timber crib breakwater (16 ft wide) was completed connecting the original structure to shore (Figures 45 and 46, Section A).
1927	A stone and concrete capped superstructure was built on the existing structures (Figures 45 and 46, Sections A and B). The crest el of the structure was +8 ft lwd.
1938	Construction of the breakwater head was completed. The structure was a stone-filled timber crib breakwater that was 30 ft in width (Figures 45 and 46, Section D). The stone portion of the substructure and stone placed on the lakeward side of the breakwater were installed at an el of +8 ft lwd. Armor stone on the lakeside and toe protection on the harbor side of the structure were in the 10-ton range. The concrete superstructure was built to an el of +16 ft lwd for a lighthouse.
1938- 1939	A 1,600-ft-long rubble-mound breakwater was constructed connecting the breakwater head to the existing structure (Figures 45 and 46, Section C). The crest was 12 ft wide with an el of +8 ft lwd. Ten-ton armor stone was used.
1963	Riprap cover stone (5.5 ton) was installed for a distance of 180 ft on the harbor side and 400 ft on the lakeward side of the original timber crib structure (Figure 46, Section B). The inner 1,216 ft of breakwater was rehabilitated for a cost of \$76,500.
1975	An inspection of the site indicated that the outermost portion of the rubble-mound breakwater needed some minor stone rearranging. This work was completed later in the year.
1986	The breakwater presently is in good condition. An aerial view of Presque Isle Harbor breakwater is shown in Figure 47.

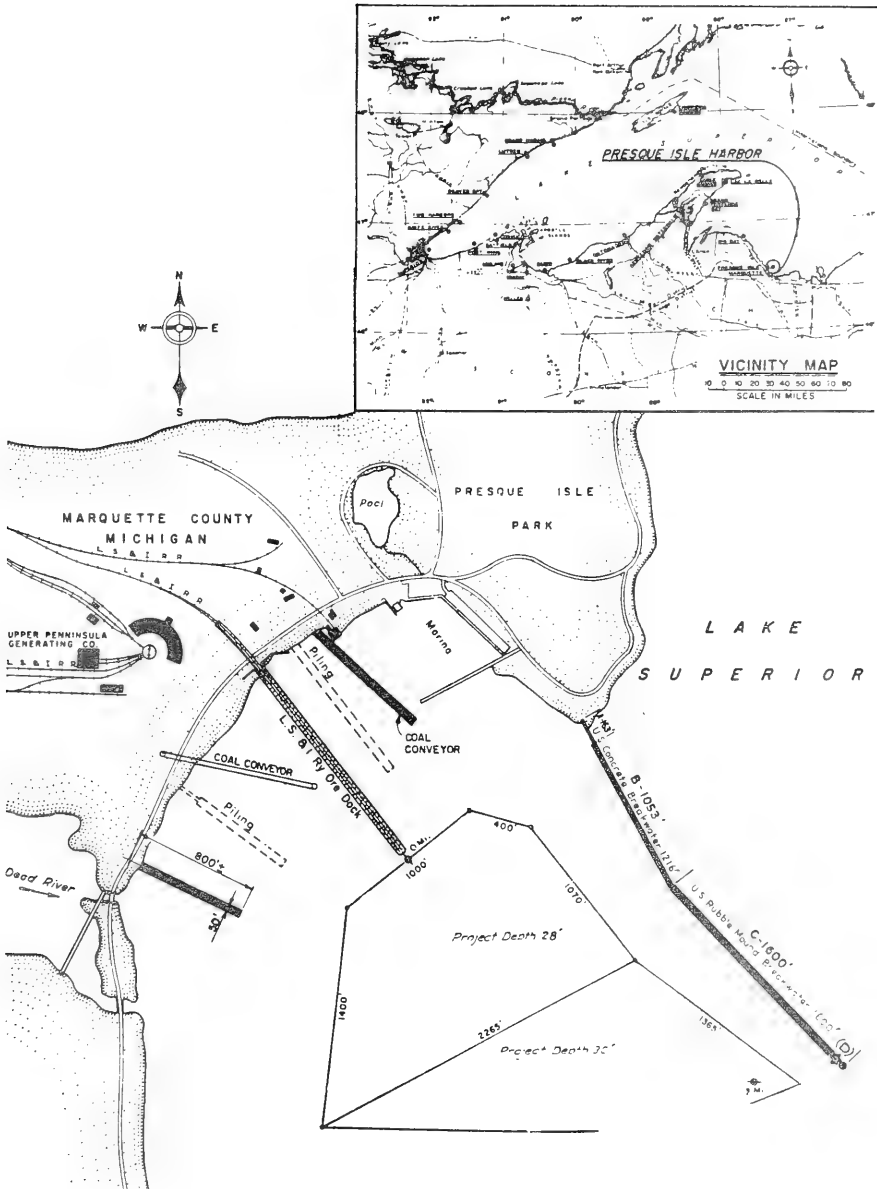
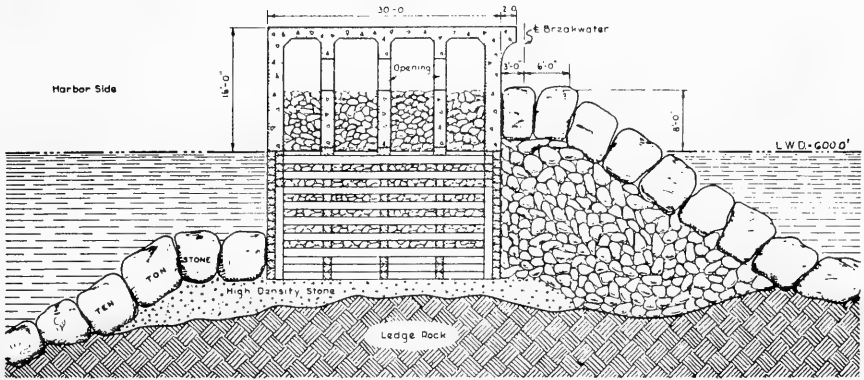
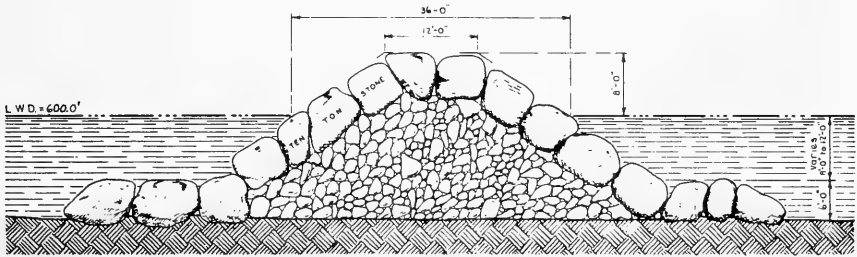


Figure 45. Presque Isle Harbor, Michigan

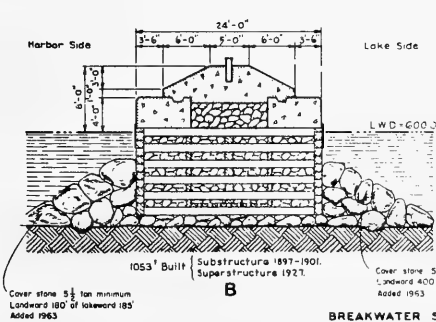




Lighthouse Foundation  
Built 1938.  
**D**



Outer 1600' Built 1938-39  
**C**

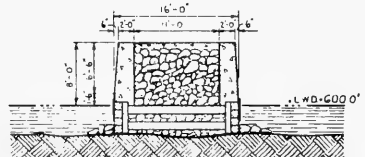


Cover stone  $\frac{5}{8}$  ton minimum  
Lansdown 180 of lotseward 185  
Added 1963

1053' Built Substructure 1897-1901.  
Superstructure 1921.

Cover stone  $\frac{5}{8}$  ton minimum  
Lansdown 400 of lotseward 630  
Added 1963

**B**



1169' 63' Built Substructure 1903  
Superstructure 1921

**A**

**BREAKWATER SECTIONS**

Figure 46. Typical breakwater cross sections,  
Presque Isle Harbor, Michigan



Figure 47. Aerial view of Presque Isle Harbor, Michigan

Table 18  
Marquette Harbor Breakwater  
Marquette, Michigan

Date(s)	Construction and Rehabilitation History
1867	Construction of the inner 410 ft of the breakwater was completed (Figures 48 and 49, Sections A and B). The structure was a stone-filled timber crib breakwater. The inner 260 ft was 20 ft wide, and the remaining 150 ft was 25 ft wide.
1868- 1874	An additional 1,600 ft of breakwater was built during this time. It also was a stone-filled timber crib structure and was 30 ft wide (Figures 48 and 49, Section C).
1889- 1894	During this period the breakwater was extended an additional 1,000 ft (Figures 48 and 49, Sections D, E, F, and G). The structure was a stone-filled timber crib breakwater and was 24 ft wide. It was built on a stone base and included riprap toe protection.
1896- 1904	A concrete cap (superstructure) was added to the 1,600-ft-long breakwater built during 1868-74 (Figures 48 and 49, Section C). The crest el of the structure was +10 ft lwd.
1897- 1905	A concrete cap (superstructure) was installed on the remaining portion of the breakwater (Figures 48 and 49, Sections A, B, D, E, F, and G). The superstructure was built to an el of about +10 ft lwd. Stone was added on the lakeside of the inner 410 ft (Sections A and B), and on both sides of the 123-ft-long section designated as G (Figures 48 and 49).
1912- 1918	The breakwater was extended an additional 1,500 ft during this period. The extension consisted of a rubble-mound structure (Figures 48 and 49, Section H). The shoreward 500 ft of structure was installed at an el of +8 ft lwd, and the outer 1,000 ft was constructed to a +10 ft lwd el. The breakwater was constructed of 10-ton armor stone.
1920- 1923	Riprap was placed on the lakeside of the 1,600-ft-long breakwater originally constructed from 1868-74 (Figure 49, Section C).
1965	Rehabilitation of the inner 3,010 ft of the breakwater was completed for a cost of \$465,747.
1979	Stone placement along a 500-ft section of the breakwater (sta 22+50 to 27+50) was completed. Also the placement of riprap stabilizing stone at the lakeward structure toe was completed.
1986	The breakwater presently is in very good condition. An aerial view of Marquette Harbor breakwater is shown in Figure 50.

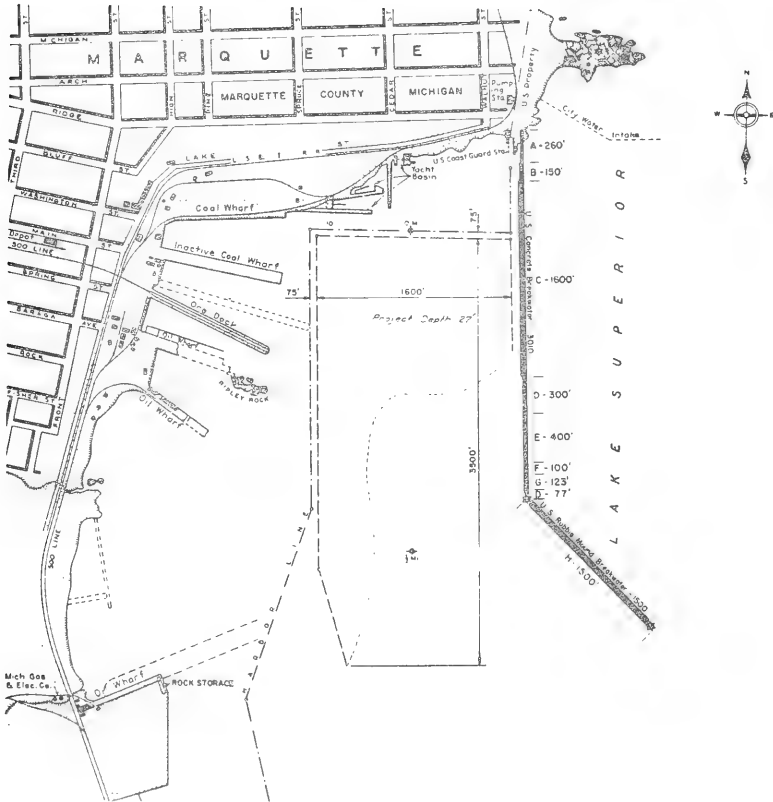
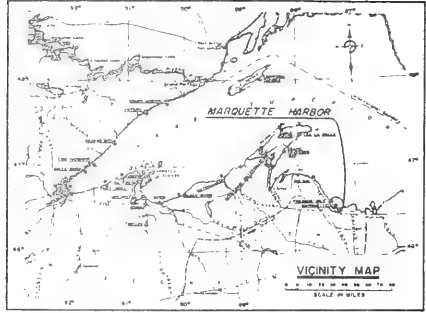


Figure 48. Marquette Harbor, Michigan

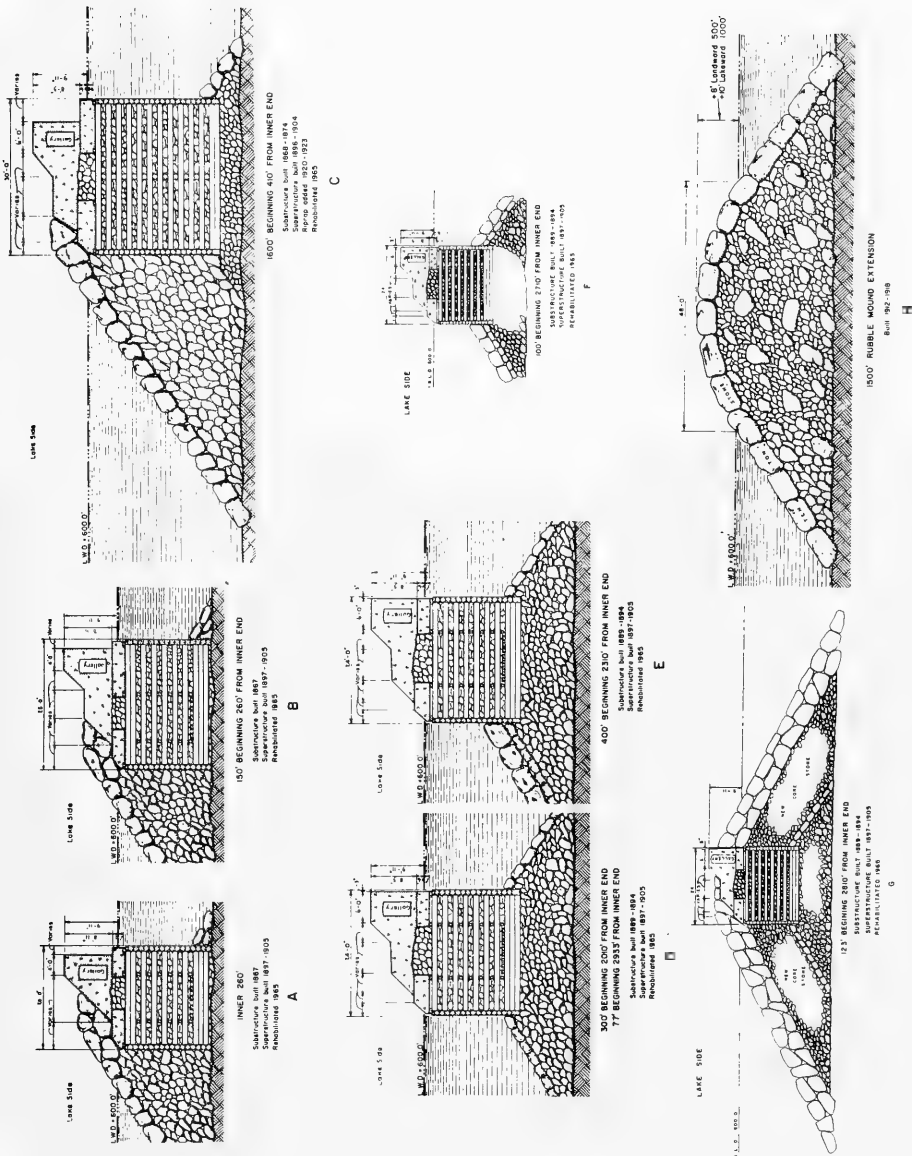


Figure 49. Typical breakwater cross sections, Marquette Harbor, Michigan



Figure 50. Aerial view of Marquette Harbor, Michigan

Table 19  
Grand Marais Harbor Piers  
Grand Marais, Michigan

Date(s)	Construction and Rehabilitation History
1883- 1885	Construction of 700-ft-long portions of the east and west piers progressed during this time (Figures 51 and 52, Section B). It was a timber crib structure with a 20.5-ft width and was built on a stone blanket. Stone protection also was included in construction.
1885- 1903	A 1,112-ft-long portion of the west pier (a timber crib structure) was constructed during this period (Figures 51 and 52, Section A). It was 24.5 ft wide. The structure was built on a stone mattress, and riprap was placed along the sides for toe protection.
1892	The inner 250-ft-long portion of the east pier and 100-ft-long portion of the west pier were completed (Figures 51 and 52, Section C). These were wood-pile structures filled with sand and stone. They were 12.5 ft wide with crest els of +6 ft lwd. Stone was placed on the channel side of the structures.
1893- 1903	The outer 745-ft-long portion of the east pier (Figures 51 and 52, Section E) was constructed during this period. This was a 24-ft-wide stone-filled timber crib structure. It was built on stone, and riprap was placed on each side of the structure.
1895- 1898	A 5,770-ft-long timber-pile dike (Figures 51 and 52, Section D) was constructed during this time. It was installed at an el of +4 ft lwd.
1905- 1907	Stone reinforcement was added along the timber-pile dike built during 1895-98. The stone crest was 10 ft wide at an el of +4 ft lwd.
1914	Timber crib structures on the west pier (Figures 51 and 52, Section A) were repaired. Crib walls were repaired with tie rods, and 425 tons of crib-fill stone was installed in the outer 500-ft portion of the pier.
1936- 1942	Repairs were made to the east and west piers (Figures 51 and 52, Section B). These included replacing decaying, broken, or missing deck planking and replenishing crib-fill stone.
1950- 1951	A concrete cap (superstructure) was installed on the east pier (Figures 51 and 52, Section E). The cap extended to an el of +6 ft lwd.
1960	Construction of an 802-ft-long cellular sheet-pile breakwater extension was completed at the lakeward end of the west pier (Figures 51 and 52). The lakeward 307 ft of the structure was constructed with 58.9-ft diameter cells, and the remaining portion was built with

(Continued)

Table 19 (Concluded)

Date(s)	Construction and Rehabilitation History
	46.1-ft diameter cells. The cells were filled with dredged fill material and capped with 3-ton (minimum) cover stone. The crest el of the structure was +8 ft lwd. Riprap stone was placed around the toe of the cells.
1971	Portions of the east and west piers (Figures 51 and 52, Sections A and B) were capped with concrete. The new superstructures extended to els of +7 ft lwd.
1986	The east and west piers have undergone additional maintenance and presently are in fair condition. The pile dike, which is not included in the present project, is badly deteriorated and in ruins. An aerial view of Grand Marais Harbor piers is shown in Figure 53.





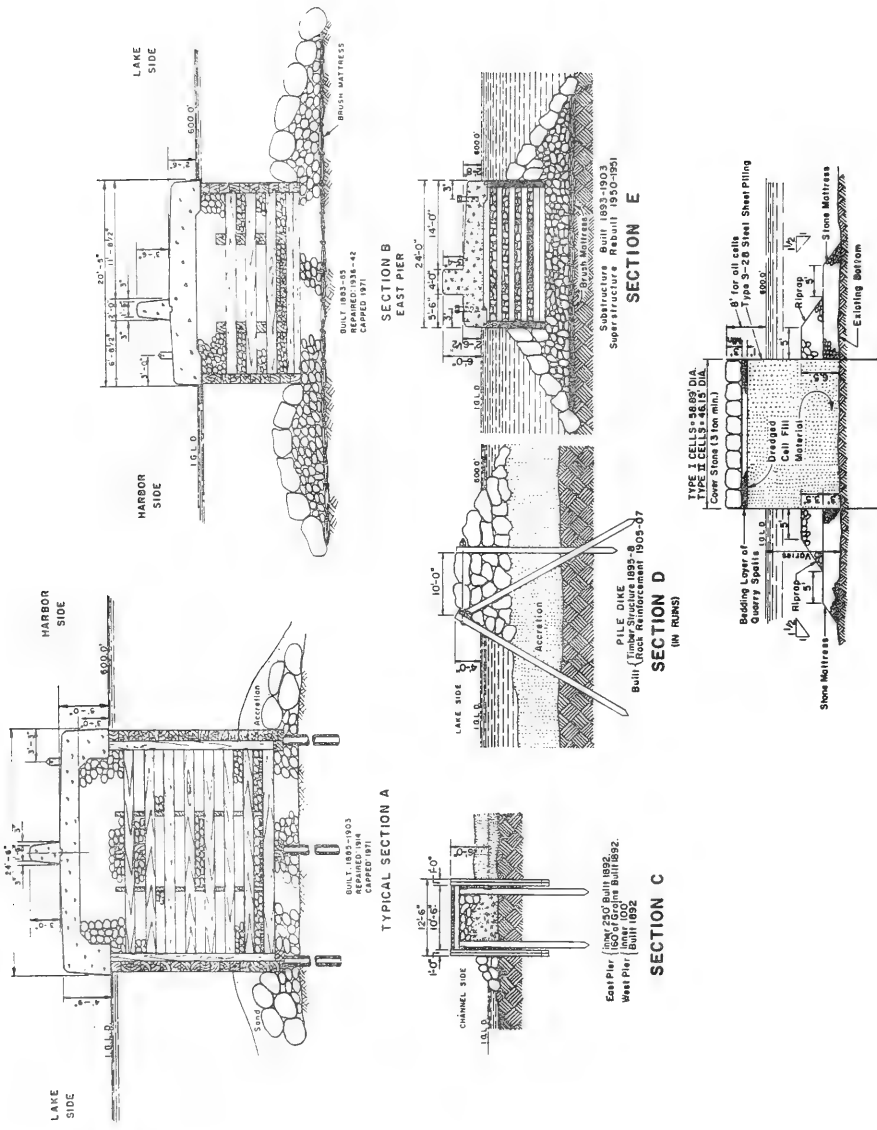


Figure 52. Typical structure cross sections, Grand Marais Harbor, Michigan



Figure 53. Aerial view of Grand Marais Harbor, Michigan

Table 20

Little Lake Harbor BreakwatersLittle Lake, Michigan

<u>Date(s)</u>	<u>Construction and Rehabilitation History</u>
1964	<p>Construction of a 270-ft-long east breakwater and a 1,000-ft-long west breakwater was completed at the site (Figure 54). These were rubble-mound structures with cellular steel sheet-pile heads. The east breakwater included 3-ton (minimum) cover stone and an 8-ft-wide crest width. The side slopes were 1V:1.75H and 1V:1.5H on the lake-side and harbor side, respectively. The elevation of the structure was +8 ft lwd from the -6 ft contour lakeward and +6 ft lwd shoreward. Stone of 5 tons (minimum) was also used (Figure 55). A 20.7-ft diameter cellular steel sheet-pile breakwater head was built on the lakeward end. The cell was sand filled and capped with asphalt. Its crest el was +8 ft lwd, and stone riprap was installed around the structure (Figure 55). The west breakwater consisted of the same cross section as the east structure (Figures 54 and 55), except portions of the breakwater were constructed of 5-ton (minimum) cover stone and 7-ton (minimum) toe stone. The west breakwater head consisted of two 36.6-ft-diameter cellular steel sheet-pile structures. The cells were sand filled and capped with 3-ton (minimum) cover stone. Their crest el was +8 ft lwd, and riprap was installed around the structures (Figure 55).</p>
1986	<p>The condition of the breakwaters is very good at present. The project provides protection for recreational craft; however, entrance into Little Lake during periods of storms is still hazardous because of the scattered shoals in the channel entrance. Maintenance dredging is required annually. A model study was conducted to aid in the development of the most economical plan to minimize shoaling without adversely impacting navigation (Seabergh and McCoy 1982). Construction improvements have not been performed, however.</p>

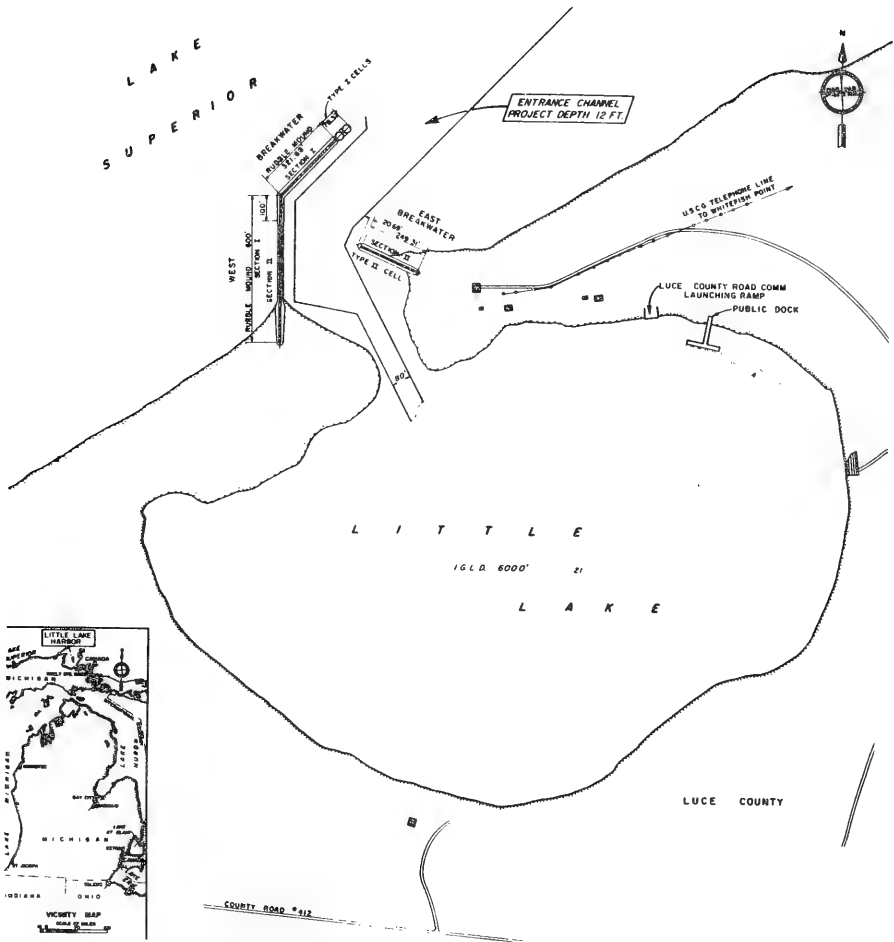
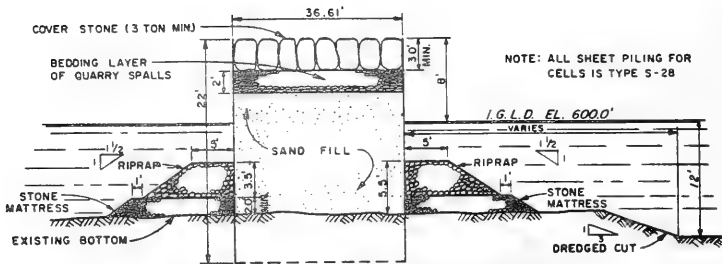
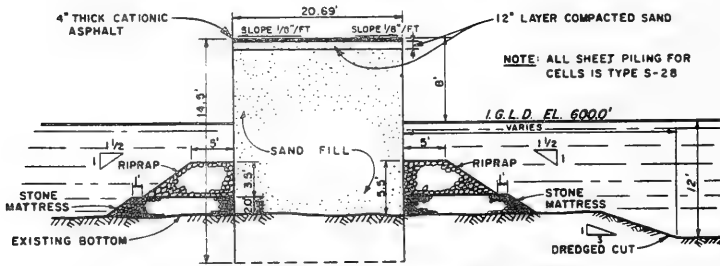


Figure 54. Little Lake Harbor, Michigan



TYPICAL CROSS SECTION—TYPE I CELLULAR BREAKWATER  
NO SCALE



TYPICAL CROSS SECTION—TYPE II CELLULAR BREAKWATER  
NO SCALE

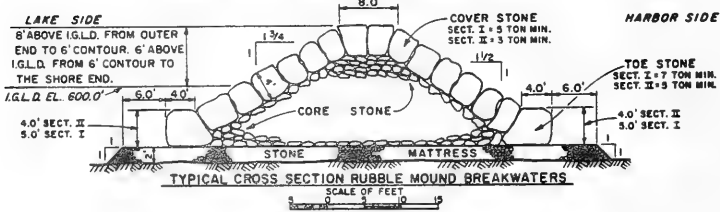


Figure 55. Typical breakwater cross sections,  
Little Lake Harbor, Michigan

Table 21

Whitefish Point Harbor BreakwatersWhitefish Point, Michigan

<u>Date(s)</u>	<u>Construction and Rehabilitation History</u>
1968	Construction of a 507-ft-long south breakwater and a 587-ft-long north breakwater was completed at the site (Figure 56). The south breakwater consisted of a 323-ft-long steel sheet-pile cantilever wall and a 184-ft-long sand-filled cellular steel sheet-pile structure (Figure 56). The cells were 25.5 ft in diameter and were capped with reinforced concrete. Riprap was placed on each side of the cells. The entire breakwater was constructed to a +8 ft lwd el. The north breakwater was constructed with sand-filled cellular steel sheet-pile structures that were also capped with reinforced concrete. The shoreward cells were 25.5 ft in diameter, while the lakeward cells had a diameter of 30.2 ft (Figures 56 and 57). Riprap was placed on each side of the structure, and the crest el was +8 ft lwd.
1969	A 270-ft-long interior breakwater was constructed (Figure 56) for wave absorption. This structure consisted of steel sheetpiling installed at an el of +8 ft lwd and riprap installed at 0.0 ft lwd on each side of the structure (Figure 57). The weight of the riprap ranged from 1,600 to 6,000 lb, and about 6,860 tons of stone was used. The cost of this structure was approximately \$112,000.
1986	The breakwaters appear to be functioning well and presently are in good condition. An aerial view of Whitefish Point Harbor breakwaters is shown in Figure 58.

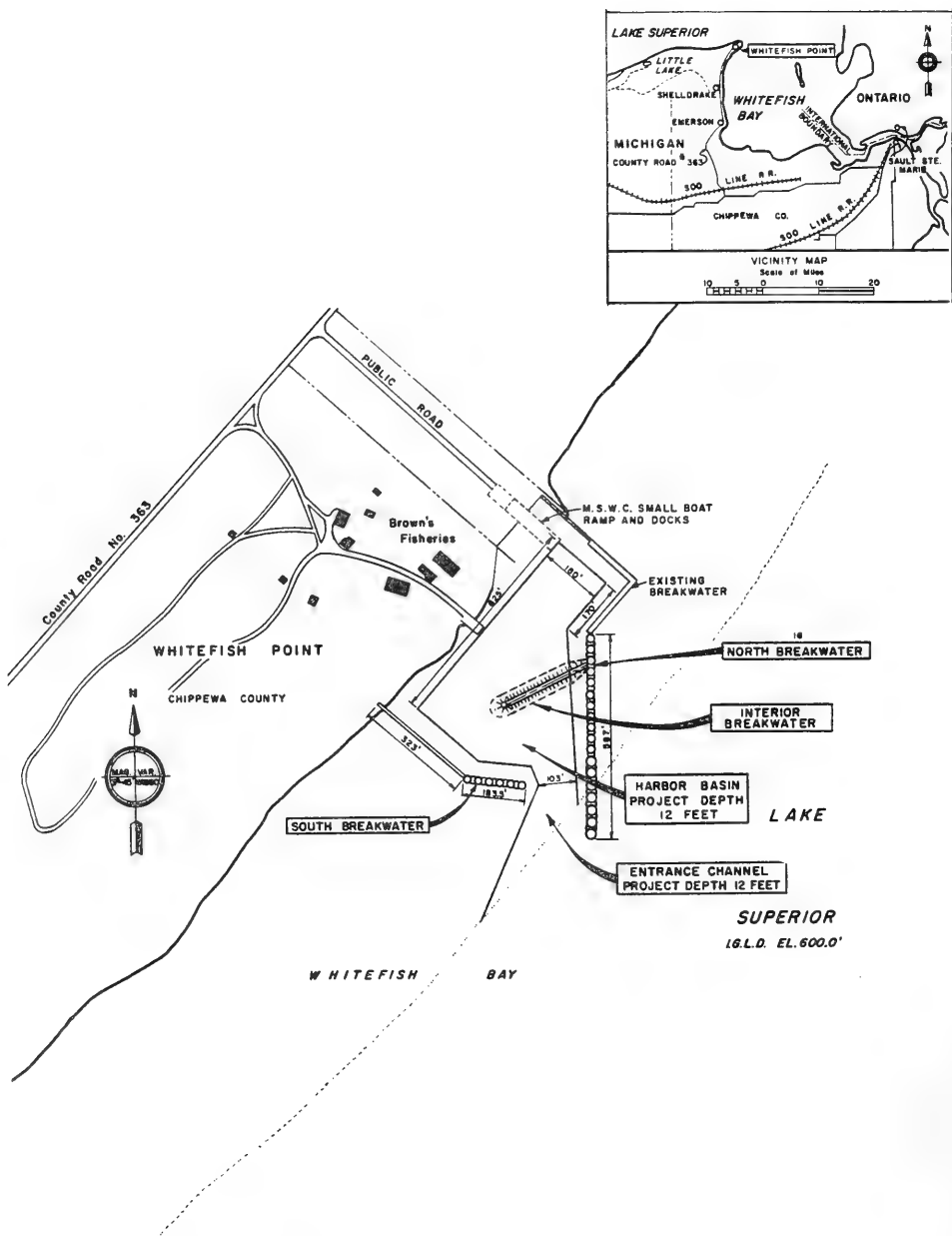
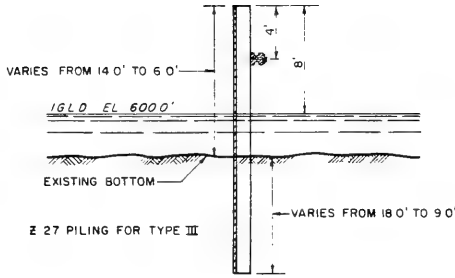


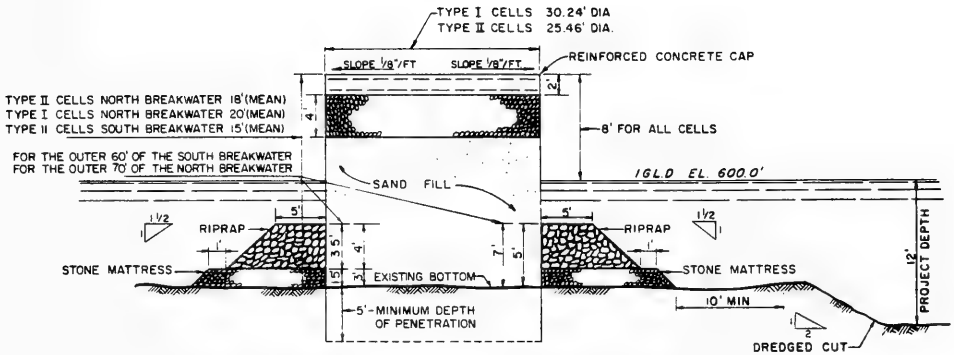
Figure 56. Whitefish Point Harbor, Michigan





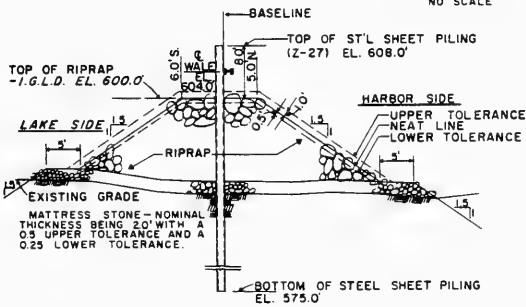
**SHEET PILING SECTION OF CANTILEVER WALL**

NO SCALE



**TYPICAL CROSS SECTION - CELLULAR BREAKWATER**

NO SCALE



**NOTE:** ALL SHEET PILING FOR CELLS IS TYPE S-28 FILL PIPES NOT SHOWN ON THIS TYPICAL CROSS SECTION.

**TYPICAL SECTION - INTERIOR BREAKWATER**

NO SCALE

Figure 57. Typical structure cross sections, Whitefish Point Harbor, Michigan



Figure 58. Aerial view of Whitefish Point Harbor, Michigan

Table 22

Manistique Harbor BreakwatersManistique, Michigan

Date(s)	Construction and Rehabilitation History
1887	A 420-ft-long timber crib breakwater was constructed offshore of the site (Figures 59 and 60, Section E). The structure was about 29 ft wide, and stone was placed on each side of the breakwater. Core stone ranged from 2 to 3 ft in thickness, and cover stone was a minimum of 4.5 ft thick.
1909	A 322-ft-long stone-filled timber crib pier was completed west of the harbor entrance (Figures 59 and 61, Section H). The pier was approximately 20 ft wide and installed at an el of +4 ft lwd. The lakeward portion of the structure included a concrete cap (cast in place) and riprap toe protection. The rest of the pier consisted of a cap of precast concrete blocks and stone.
1911- 1915	During this time, construction of the east and west breakwaters was completed (Figure 59, Sections A-G). The 420-ft-long breakwater (built in 1887) was capped with concrete and became a portion of the east breakwater. The shoreward 624 ft of the east breakwater and 480 ft of the west breakwater (Figure 60, Sections A and B) were constructed of woodpiling and stone. The superstructure consisted of a concrete cap and stone. The shoreward portion (Section A) was 8 ft wide, and the rest of the structure (Section B) was 11 ft wide. The crest el was +7.1 ft lwd, and stone was included on both sides. The 1,000-ft-long lakeward end of the west breakwater and 300 ft of the east breakwater shoreward of the dogleg section (Figures 59 and 60, Sections C and D) consisted of wooden crib construction with concrete caps. The 300 ft of east breakwater and 500-ft-long shoreward end of the portion of the west breakwater (Section C) were 20 ft wide. The outer 500-ft-long portion of the west structure (Section D) was built 24 ft wide. The breakwaters (Sections C and D) had a +7.1 ft lwd crest el. The outer 400 ft of the east breakwater (Figures 59 and 61, Sections F and G) consisted of timber crib construction with concrete caps. The breakwater was 24 ft wide and had a crest el of +7.1 ft lwd.
1953	The shoreward end of the east breakwater was extended 200 ft to shore and 300 ft parallel to the shoreline (Figures 59 and 61, Section I). The structure was of rubble-mound construction with 1V:1.5H side slopes. It had an 8-ft crest width and +7.0 ft lwd crest el. Cover stone on the lakeside ranged from 1 to 3 tons and on the harbor side from 0.5 to 1.5 tons. The structure presently is entirely on shore.
1957	The superstructure of the inner 924 ft of the east breakwater (Figure 59, Sections A, B, and C) was refilled with stone.

(Continued)

Table 22 (Concluded)

Date(s)	Construction and Rehabilitation History
1958	Riprap was placed on both sides of the east breakwater on the outer 100 ft of Section C (Figures 59 and 60). The outer 820 ft of the east breakwater (Figures 59-61, Sections E-G) was reconstructed during this period as rubble-mound breakwaters.
1961	Riprap was placed around the outer end of the west breakwater and for a distance of 200 ft on each side (Figure 59, Section D). Riprap also was placed around the outer end of the east breakwater and 150 ft along each side (Figure 59, Sections F and G).
1963	Rehabilitation of navigation structures included reconstruction of the inner 470 ft and 624 ft of the west and east breakwaters, respectively (Figure 59, Sections A and B). Also included in the rehabilitation was reconstruction of the pier (Figure 59, Section H). The shoreward 88 ft of the pier included a rubble-mound structure (Figure 61, Section H), 8 ft wide, with a crest el of +4 ft lwd and side slopes of 1V:1.5H.
1981	An inspection of the breakwaters revealed that the east breakwater had some areas where the concrete cap was in an advanced state of deterioration, and the stone fill had washed away. The west breakwater required some stone fill also and new concrete in some areas. Breakwater repairs were made subsequent to the inspection.
1986	The structures have been reconstructed and repaired during their history and presently are in fair condition.

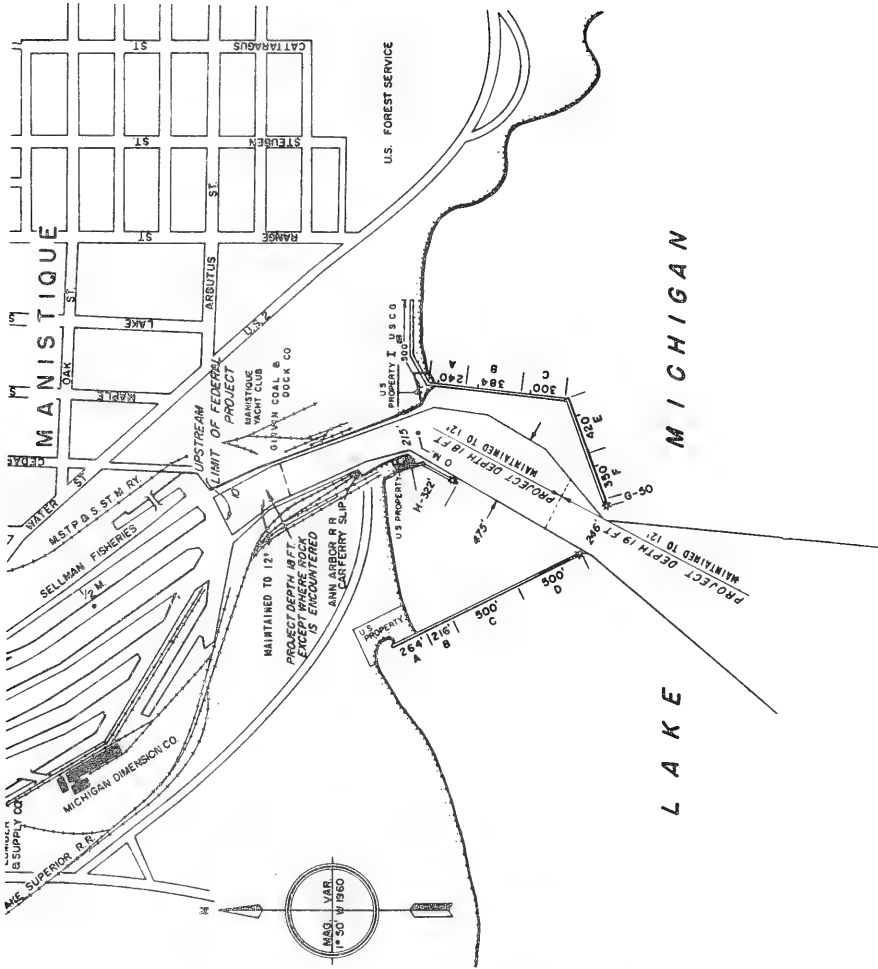


Figure 59. Manistique Harbor, Michigan

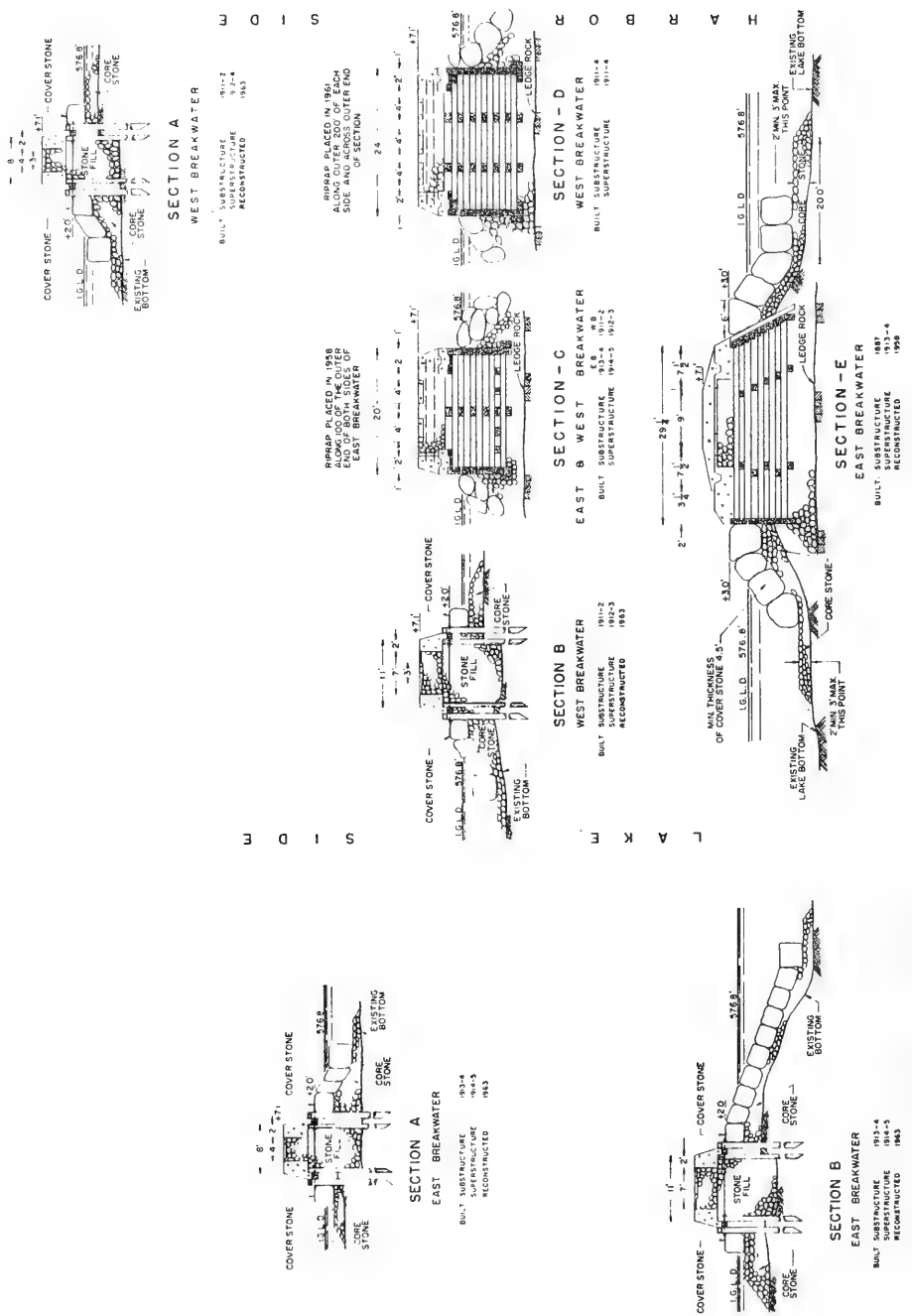


Figure 60. Typical breakwater cross sections, Manistique Harbor, Michigan

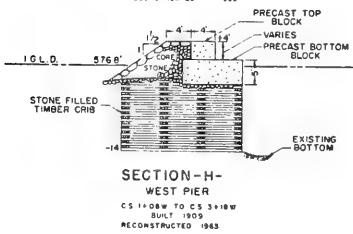
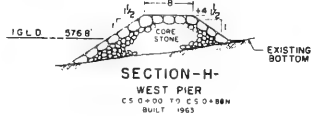
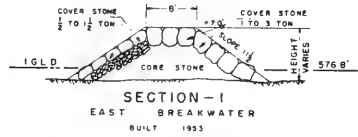
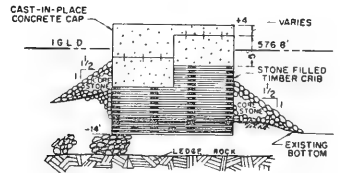
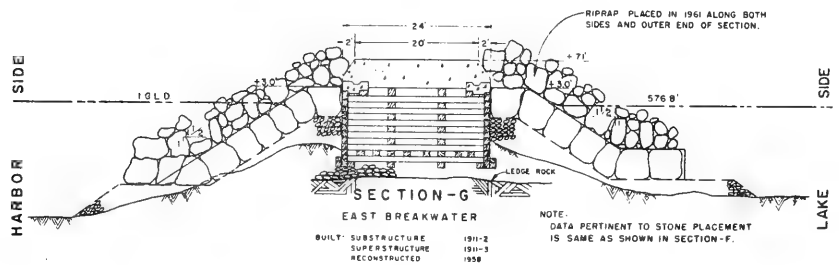
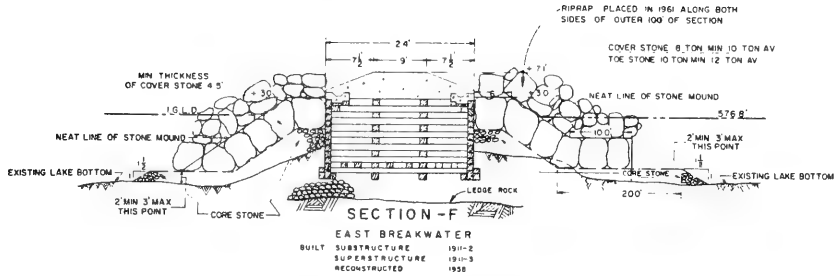


Figure 61. Typical structure cross sections, Manistique Harbor, Michigan

Table 23

Cedar River Harbor Piers

Cedar River, Michigan

Date(s)	Construction and Rehabilitation History
1883-1885	A 750-ft-long west pier and a 350-ft-long east pier were constructed during this period at the mouth of Cedar River (Figure 62). These structures were built with wood piles spaced 14 ft apart (width) and filled with stone (Figure 62). The original crest el was +8.2 ft lwd. A timber cap provided a 16-ft-wide crest width.
1965	Construction of a new west pier and a 2,100-ft-long rubble-mound east pier with a cellular sheet-pile pierhead (Figure 62) was authorized. Construction, however, has not yet occurred.
1986	The existing piers are in ruins.

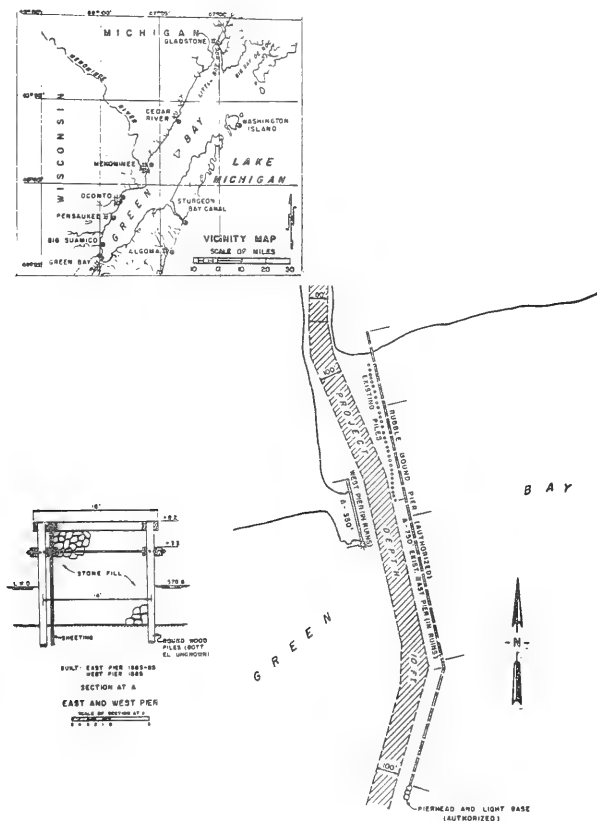


Figure 62. Cedar River Harbor, Michigan



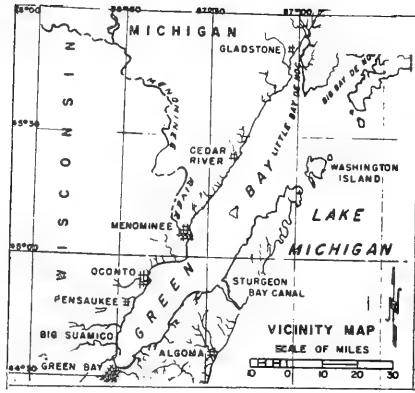
Table 24  
Menominee Harbor Piers  
Menominee, Michigan

<u>Date(s)</u>	<u>Construction and Rehabilitation History</u>
1871- 1874	Construction of a 566-ft-long north pier (Figure 63, Sections A and B) and a 1,913-ft-long south pier (Figure 63, Sections E, F, A, and B) were completed during this time. The piers were initially constructed with woodpiling and stone. The pilings were installed 13 ft apart on the shoreward ends of the piers (Figure 64, Sections E, F, and A) and 17 ft apart on the lakeward ends of the structures (Figure 63, Section B).
1877- 1879	Extensions of the north and south piers by 596 ft and 613 ft, respectively, were completed (Figure 63, Section C). The extensions consisted of stone-filled timber crib structures (Figure 64, Section C).
1883- 1884	Construction of the heads of the north and south piers was completed (Figure 63, Section D). The lakeward end of the north pier was 62 ft long and was of stone-filled timber crib construction, while the lakeward end of the south pier was 162 ft long and was of rubble-mound construction (Figure 64, Section D).
1912	The shoreward 566-ft portion of the north pier was reconstructed, (Figure 63, Sections A and B). Steel sheetpiling was installed that resulted in pier widths ranging from 21 to 27 ft. The structures were stone filled and capped with a concrete superstructure at an el of +7.0 ft lwd (Figure 64, Sections A and B). Riprap toe protection also was installed.
1915	A 508-ft-long portion of the south pier (Figure 63, Sections A and B) and a 596-ft-long portion of the north pier (Figure 63, Section C) was reconstructed in a manner similar to that in 1912. Steel sheetpiling was installed, filled with stone, and capped with a concrete superstructure to an el of +7.0 ft lwd (Figure 64, Sections A, B, and C). A 412-ft portion of the south pier had a 20-ft width (Section A) and the remaining 96-ft portion a width of 25 ft (Section B). the north pier portion (596 ft long) had a width of 27 ft (Section C). Riprap toe protection also was placed on each side of both piers.
1922	The 162-ft-long lakeward end of the south pier was modified (Figure 63, Section D). A rock-filled concrete superstructure was built on the existing rubble-mound pier. The superstructure had a crest el of +7.1 ft lwd with an 8-ft width (Figure 64, Section C).
1927	A 613-ft-long portion of the south pier (Figure 63, Section C) and the 62-ft-long lakeward end of the north pier (Figure 63, Section D) were reconstructed. Steel sheetpiling was placed a width of 30.3 ft apart on the south pier (Figure 64, Section C). The voids were filled with stone, and a concrete superstructure with a crest el of +7.0 ft was installed. Riprap toe protection was also installed. Steel sheetpiling was installed on each side of the north pier which

(Continued)

Table 24 (Concluded)

Date(s)	Construction and Rehabilitation History
	was stone filled and capped. The outer end of the north pier, however, was constructed with a 47.75-ft-diameter cellular sheet-pile structure (Figure 64, Section D). The cell was filled with stone and gravel and capped with a concrete superstructure at an el of +8 ft lwd.
1944	An 880-ft-long portion of the south pier (Figure 63, Section F) was reconstructed similar to other sections of the pier. Steel sheet piles were installed forming a pier width of 22 ft. The voids were stone filled, and the structure was capped with a concrete superstructure installed with a crest el of +7.0 ft lwd (Figure 64, Section F).
1946	The shoreward 525-ft length of the south pier was modified (Figures 63 and 64, Section E). A rubble-mound superstructure was constructed on the existing structure. The crest width of the new superstructure was 4 ft, and it had an el of +4.5 ft lwd.
1954	The cellular sheet pile at the lakeward end of the north pier was repaired (Figure 63, Section D).
1955	A 613-ft-long section of the south pier was repaired (Figure 63, Section C).
1963	Repairs were made to a 508-ft-long section of the south pier (Figure 63, Sections A and B) and a 1,164-ft-long portion of the north pier (Figure 63, Sections A, B, and C).
1965	An 880-ft-long portion of the south pier was repaired (Figure 63, Section F).
1974	The cellular sheet-pile north pierhead was again repaired (Figure 63, Section D).
1977	The lakeward end of the south pier (Figure 63, Section D) experienced some settlement and was observed slightly leaning toward the channel. Additional riprap placement was completed in the area.
1982	A site inspection of the structures indicated that the north pier was in very good condition and that the south pier was generally in good condition. The settlement of the lakeward end of the south structure (Figure 63, Section D) appeared to have stabilized since placement of the riprap in 1977. The concrete superstructure of the portion of the pier needed maintenance however.
1986	The piers have experienced reconstruction, repairs, and maintenance during their lifetime, and they presently are considered in good condition.



# GREEN BAY

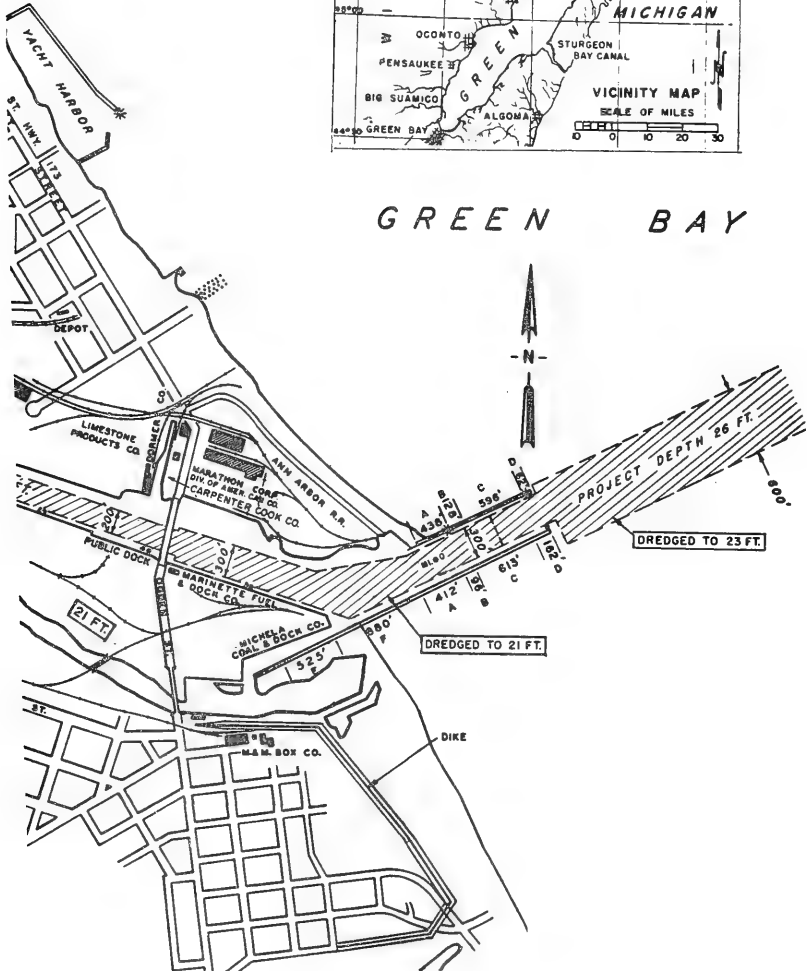


Figure 63. Menominee Harbor, Michigan

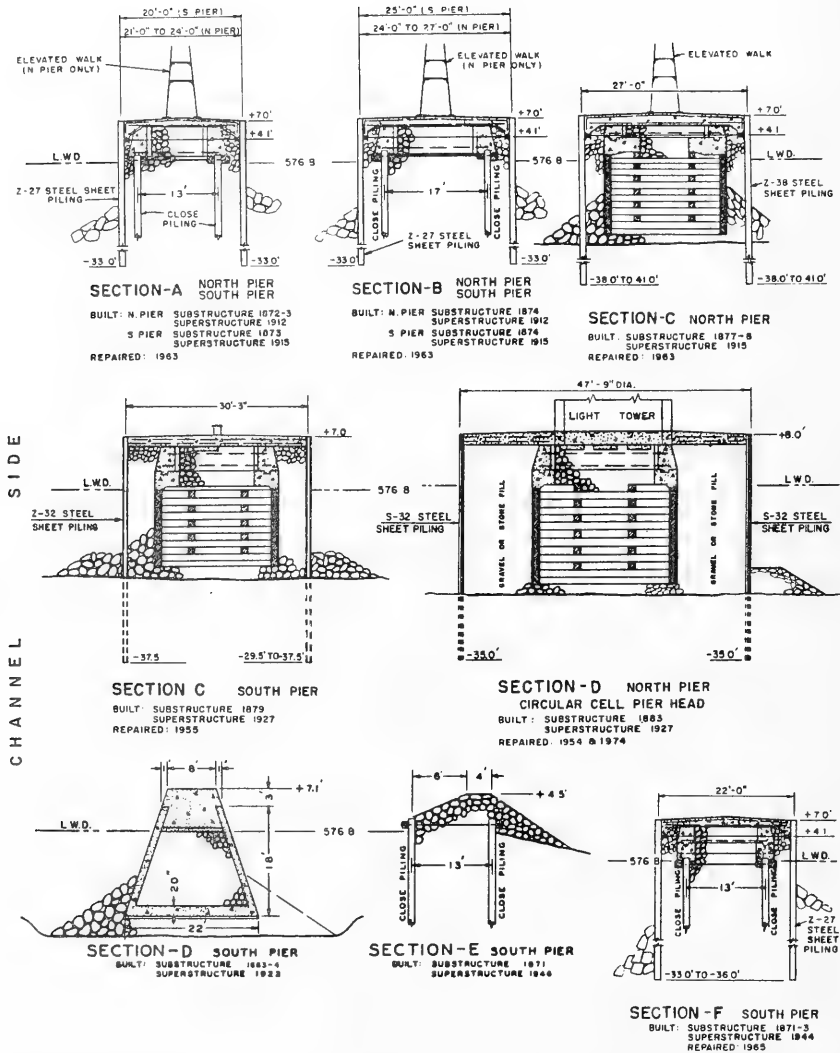


Figure 64. Typical pier cross sections, Menominee Harbor, Michigan

Table 25

Oconto Harbor PierOconto, Wisconsin

Date(s)	Construction and Rehabilitation History
1883	A 2,077-ft-long south pier was completed as a Federal project (Figure 65, Sections B-E). The structure consisted of woodpilings filled with sand and gravel (Figure 66, Sections B-E). A rubble-mound north pier was built by local interests.
1957	Construction of the 67-ft-long lakeward end of the south pier was completed (Figure 65, Section A). The extension consisted of 30.5-ft diameter cellular steel sheet-pile structures. The cells were filled with gravel and stone and had crest els of +8.5 lwd. The lakeward cell was capped with concrete, and the adjacent cell was capped with 3- to 5-ton capstone (Figure 66, Section A).
1974- 1975	The original 2,077-ft-long pier was reconstructed. Ruins of the existing structure were capped with stone. The 227-ft-long lakeward portion of the original structure (Figure 65, Section B) consisted of a rubble-mound structure with a crest el of +10 ft lwd and a width of 9 ft. Side slopes were installed at 1V:1.5H (Figure 66, Section B). The remaining portion of the existing breakwater (Figure 65, Sections C-E) consisted of a rubble-mound structure with a crest el of +8 ft lwd and a width of 7 ft. Stone ranging from 400 to 1,000 lb was used as armor, and side slopes of 1V:1.5H (Figure 66, Sections C-E) were constructed.
1986	The structure is considered to presently be in good condition.

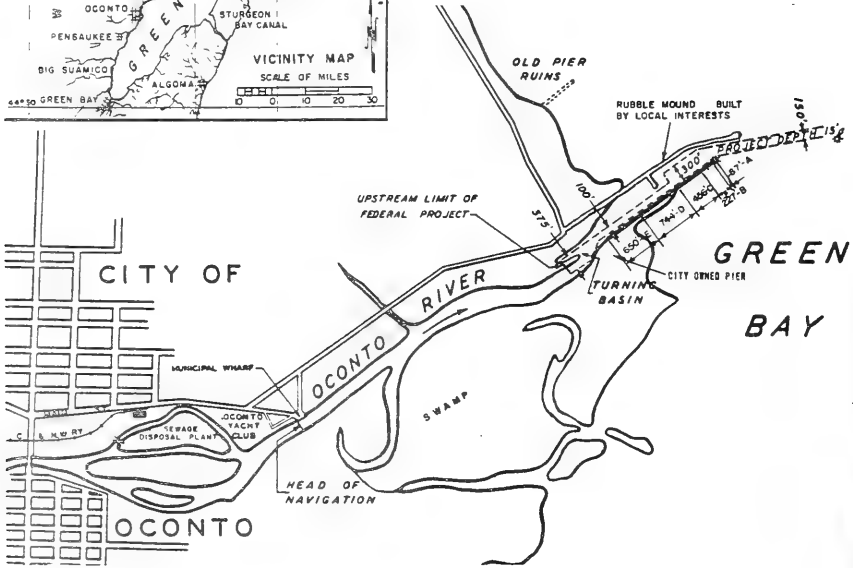
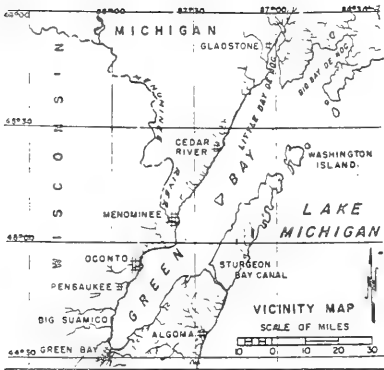


Figure 65. Oconto Harbor, Wisconsin

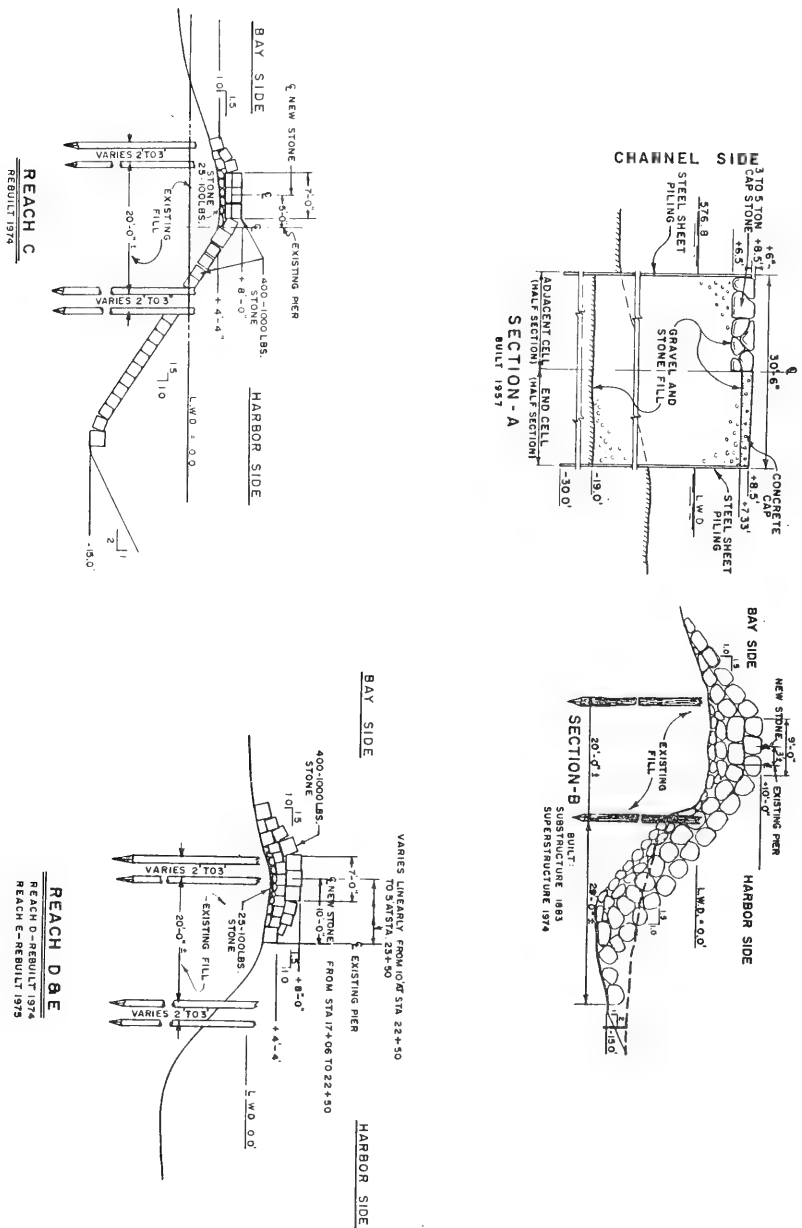


Figure 66. Typical structure cross sections, Oconto Harbor, Wisconsin

Table 26  
Sturgeon Bay Breakwaters  
Sturgeon Bay Canal, Wisconsin

<u>Date(s)</u>	<u>Construction and Rehabilitation History</u>
1873- 1880	Construction of arrowhead breakwaters was completed at the entrance canal to Sturgeon Bay (Figure 67) during this time. The breakwaters were each constructed 1,344 ft long. The shorewardmost portions of each structure (Figure 68, Sections A and B) were constructed of woodpilings, and the remaining portions of the breakwaters were of stone-filled timber crib construction. Riprap breakwater toe protection was also provided. The shoreward 762-ft lengths of each breakwater (Figure 68, Section A) were constructed to a width of 15 ft. From that point lakeward, the next 32-ft lengths of each structure (Section B) were 20 ft in width; the next 100-ft lengths (Section C) were 18 ft in width; the next 300-ft lengths of each structure (Section D) were 24 ft in width; and the lakeward ends (Sections E and F, 50 ft long each) were 30 ft in width.
1927	The south breakwater was capped with a concrete superstructure (Figure 68). The crest el of the structure was +7.1 ft lwd.
1931	The north breakwater was capped with a concrete superstructure (Figure 68). The lakeward 50 ft of the structure (Section F) was installed at an el of +8.1 ft lwd, and the remaining portion of the breakwater (Sections A-D) had a +7.1-ft lwd crest el.
1983	During a site inspection of the structures no major problems were noted.
1986	The breakwaters have undergone only routine maintenance since construction and are presently considered in good condition.



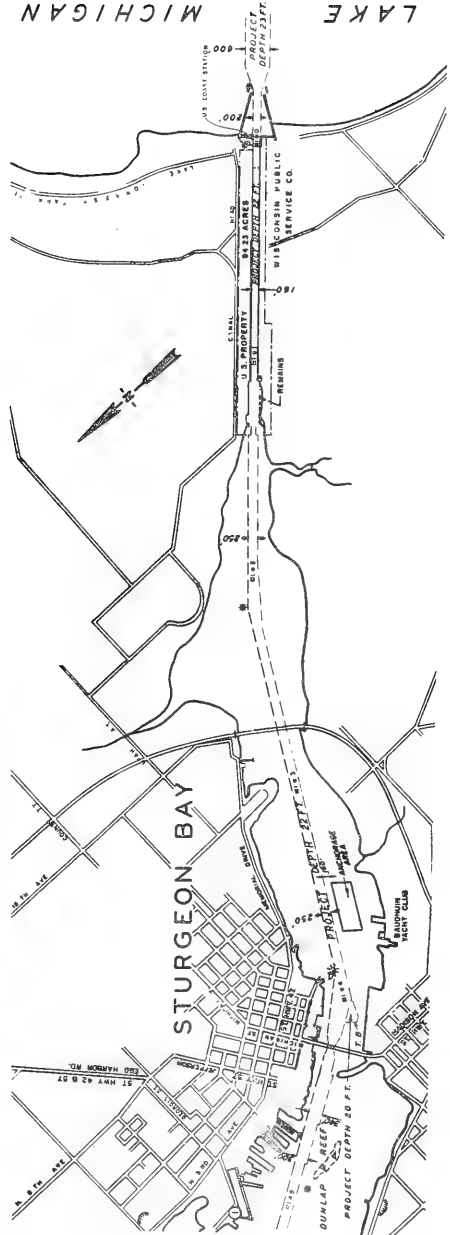
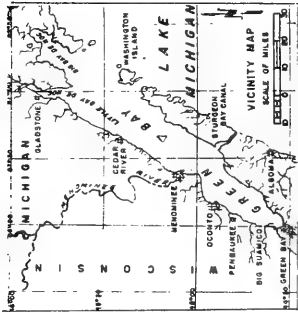
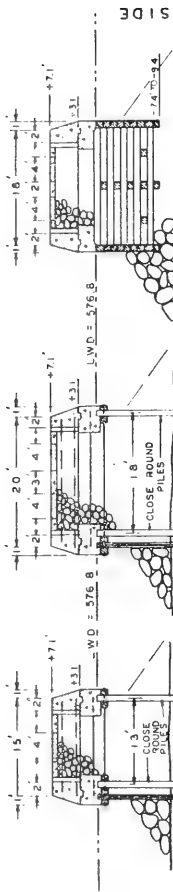


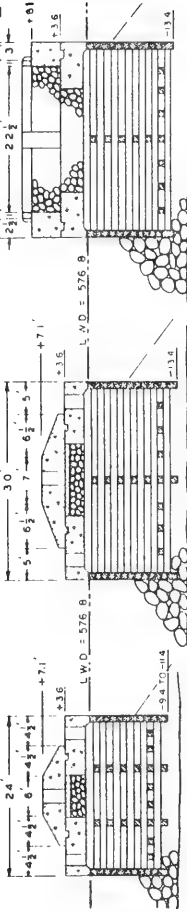
Figure 67. Sturgeon Bay, Wisconsin



**SECTION -A-N & S BREAKWATER**  
 N B W A T E R S B W A T E R  
 BUILT SUBSTRUCTURE 1880 1880  
 SUPERSTRUCTURE 1931 1927

**SECTION -B-N & S BREAKWATER**  
 N B W A T E R S B W A T E R  
 BUILT SUBSTRUCTURE 1874 1874  
 SUPERSTRUCTURE 1921 1921

**SECTION -C-N & S BREAKWATER**  
 N B W A T E R S B W A T E R  
 BUILT SUBSTRUCTURE 1875 1879  
 SUPERSTRUCTURE 1931 1927



**SECTION -D-N & S BREAKWATER**  
 N B W A T E R S B W A T E R  
 BUILT SUBSTRUCTURE 1880 1880  
 SUPERSTRUCTURE 1931 1927

**SECTION -E, SOUTH BREAKWATER**  
 BUILT SUBSTRUCTURE 1881  
 SUPERSTRUCTURE 1927

**SECTION -F, NORTH BREAKWATER**  
 BUILT SUBSTRUCTURE 1880  
 SUPERSTRUCTURE 1931

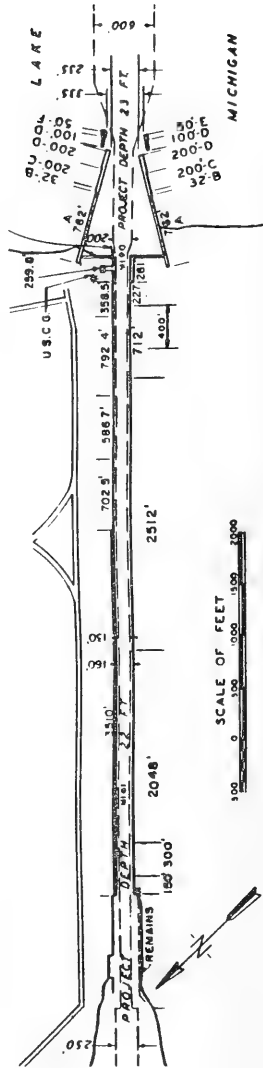


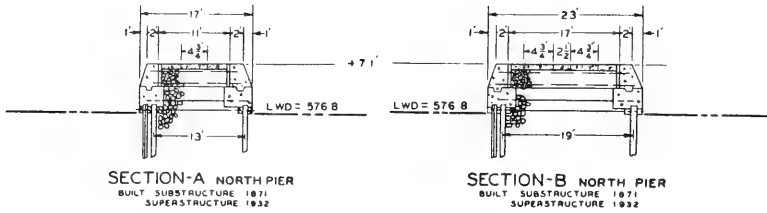
Figure 68. Typical breakwater cross sections, Sturgeon Bay, Wisconsin

Table 27  
Algoma Harbor Structures  
Algoma, Wisconsin

<u>Date(s)</u>	<u>Construction and Rehabilitation History</u>
1871	Construction of a 352-ft-long north pier was completed (Figure 69, Sections A and B). The structures were built of woodpilings with stone fill. The shoreward 308-ft length of the pier was 17 ft in width, and the lakeward 44 ft was 23 ft in width (Figure 70, Sections A and B).
1875- 1889	A 450-ft-long extension of the north pier, a 300-ft-long detached north breakwater, and a 101-ft-long south breakwater were constructed during this time (Figure 69, Section C). The structures were built of stone-filled wooden cribs and were 20 ft in width (Figure 70, Section C).
1908	Construction of the 1,429-ft-long shoreward portion of the south breakwater was completed (Figure 69, Sections D-F). The shoreward 200-ft length of the breakwater was a stone-filled timber crib structure (Figure 70, Section F), and the remaining portion of the breakwater was built of woodpilings filled with stone (Figure 70, Sections D and E). The structure ranged from 14 to 17 ft in width (Figure 70, Sections D-F).
1932	The north pier, the detached north breakwater, and the south breakwater, with the exception of the shoreward 200 ft in length, were capped with a concrete superstructure (Figures 69 and 70, Sections A-E). The crest el of the structures was +7.1 ft lwd.
1935	The shoreward 200-ft length of the south breakwater (Figures 69 and 70, Section F) was capped with a concrete superstructure with a +7.1 ft lwd parapet crest el.
1986	The structures have undergone maintenance, but no major repairs, and are presently in good condition.



Figure 69. Algoma Harbor, Wisconsin



SIDE

HARBOR

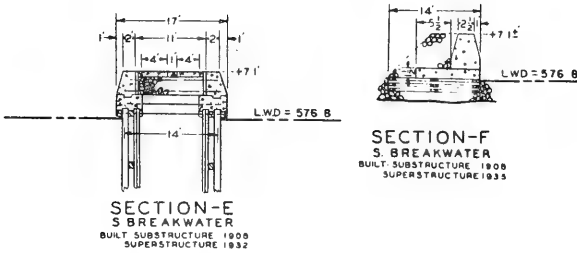
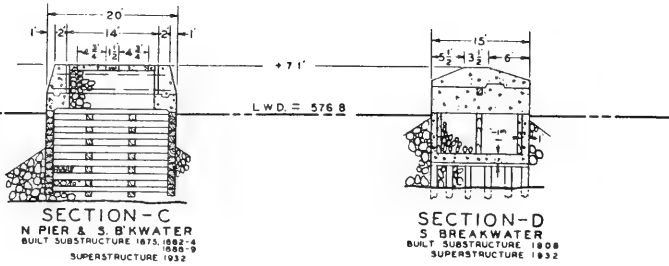


Figure 70. Typical structure cross sections,  
Algoma Harbor, Wisconsin

Table 28

Kewaunee Harbor StructuresKewaunee, Wisconsin

Date(s)	Construction and Rehabilitation History
1881- 1883	Construction of a 626-ft-long north pier (Figure 71, Section A) and the shoreward 70-ft-long portion of the south pier (Figure 71, Section C) was completed during this time. These piers were built with woodpilings installed to form a structure 14 ft wide (Figure 72, Sections A and C).
1885- 1891	A 289-ft-long portion of the south pier (Figure 71, Section B) with wood piles (Figure 72, Section B) formed a structure 14 ft wide.
1893- 1897	Construction of a 1,070-ft-long portion of the south pier (Figure 71, Sections D and D1) was completed during this period. The piers were built 18 ft in width with woodpiling that was stone filled (Figure 72, Sections D and D1).
1910- 1912	A 1,359-ft-long portion of the south pier (Figure 71, Sections B, D, and D1) was capped with a concrete superstructure.
1928	The 626-ft-long north pier was capped with a stone and concrete superstructure (Figure 72, Section A). The crest el of the pier was +7.1 ft lwd, and the width was 17.25 ft.
1933	The 70-ft-long shoreward end of the south pier had a superstructure installed which consisted of concrete on the channel side backfilled with rock (Figure 72, Section C). The crest el was +7.1 ft lwd.
1936- 1937	A 2,980-ft-long north breakwater (Figure 71, Sections F, G, and H) was constructed during this period. The shoreward 2,440 ft of the structure consisted of rubble-mound construction (Figures 71 and 72, Section H). The breakwater was constructed at a +7.0 ft lwd crest el with a width of 10 ft and side slopes of 1V:1.5H. The outer 540 ft of breakwater (Figure 71, Sections F and G) was constructed on woodpilings installed to form a width of 20 to 22 ft. A stone-filled concrete superstructure was included which was 7.3 ft wide at the crest with a +7.0 ft lwd crest el (Figure 72, Sections F and G). The outer 54-ft length of the breakwater consisted of two rectangular caissons. Stone was installed on each side of the structure to an el of -4 ft lwd.
1949	A 210-ft-long inner portion of the south pier (Figure 71, Section M) was completed. This structure consisted of steel sheetpiling (el +7.0 ft lwd) installed parallel to the shoreline and backfilled with earth (Figure 72, Section M).

(Continued)

Table 28 (Concluded)

Date(s)	Construction and Rehabilitation History
1954- 1958	Reconstruction of 45 ft of the lakeward end of the south pier (Figure 71, Section D1) occurred during this period. Steel sheetpiling was installed on each side of the existing structure forming a pier width of 26.5 ft (Figure 72, Section D1). The voids were filled with gravel and stone, and a concrete superstructure was installed at an el of +8.0 ft lwd. Riprap toe protection was installed on each side of the structure.
1956	A 211-ft-long inner portion of the south pier (Figure 71, Section E) was constructed. The pier section consisted of steel sheetpiling installed adjacent to the shoreline at an el of +7 ft lwd and back-filled with earth (Figure 72, Section E). Riprap was placed along the toe of the structure.
1966	A 969-ft-long portion of the south pier was reconstructed (Figure 71, Sections B and D). Steel sheetpiling was installed on each side of the existing pier a distance of 26.75 ft apart. The void between the sheet pile was filled with stone, and a concrete superstructure was installed (Figure 72, Sections B and D) at an el of +7.67 ft lwd.
1983	A site inspection revealed that the structures were generally in good condition. Minor concrete repairs and the placement of additional riprap were recommended for the north breakwater. The work has subsequently been completed. It was noted also that settlement of the north pier on the channel side had occurred.
1986	During their lifetime the structures have undergone reconstruction and normal maintenance repairs. Presently they are considered in good condition.





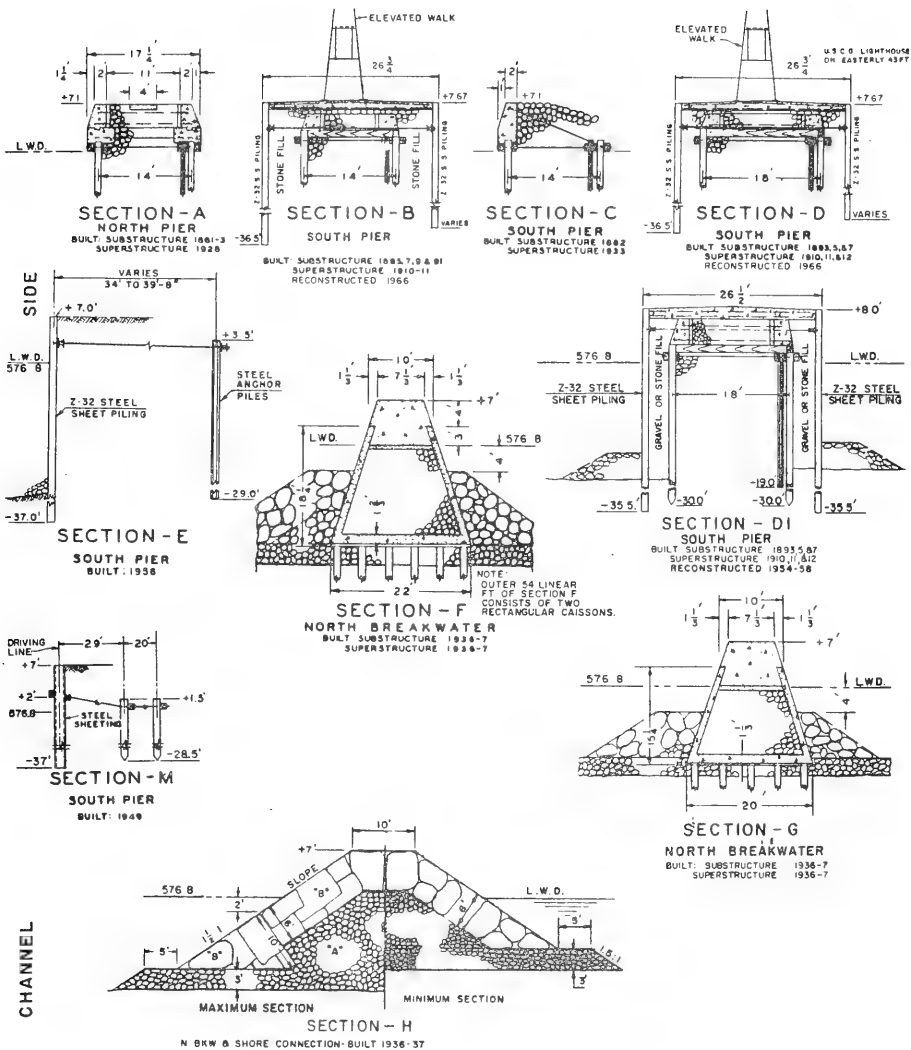


Figure 72. Typical structure cross sections, Kewaunee Harbor, Wisconsin

Table 29

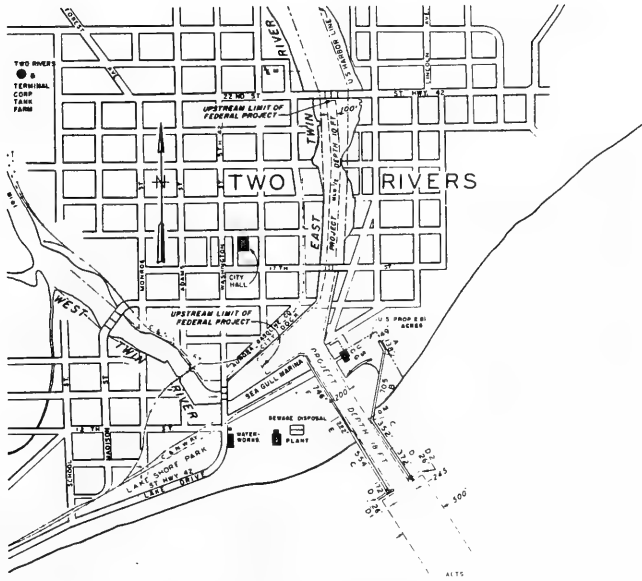
Two Rivers Harbor PiersTwo Rivers, Wisconsin

Date(s)	Construction and Rehabilitation History
1872- 1874	The shoreward 968-ft-portion of the south pier (Figure 73, Sections E and F) was constructed during this period. These were woodpiling structures (Figure 74, Sections E and F) that were stone filled.
1875- 1874	Construction of the lakeward 752 ft of the south pier and 750 ft of the north pier (Figure 73, Sections C, D, D1, and D2) were completed during this time. The structures were of stone-filled timber crib construction (Figure 74, Sections C, D, D1, and D2) and were 18 ft in width.
1875- 1883	Construction of the lakeward 752 ft of the south pier and 750 ft of the north pier (Figure 73, Sections C, D, D1, and D2) were completed during this time. The structures were of stone-filled timber crib construction (Figure 74, Sections C, D, D1, and D2) and were 18 ft in width.
1907- 1908	The shoreward 843-ft portion of the north pier (Figure 73, Sections A and B) was constructed of woodpiling (Figure 74, Sections A and B) that was stone filled. The width of the pier was 14 ft.
1929- 1931	The shoreward 843-ft portion of the north pier (Figure 73, Sections A and B) was capped with a stone and concrete superstructure (Figure 74, Sections A and B). The width of the pier was 15 ft, and the crest el was +7.3 ft lwd. The lakeward 398-ft length of the north pier and 198-ft length of the south pier were also capped with a concrete superstructure (Figures 73 and 74, Sections D, D1, and D2). The trunk portion of the structures (Section D) had a crest el of +7.3 ft lwd. Steel sheetpiling was installed around both head sections (Sections D1 and D2). The north pier head (Section D2) was 23 ft in width with a crest el of +8.25 ft lwd, and the south pier head (Section D1) was 21 ft in width with a crest el of +7.0 ft lwd. Riprap stone was placed around the pierheads for toe protection.
1937- 1941	Superstructures were constructed for the shoreward 968-ft portion of the south pier. these consisted of concrete poured to an el of +7.0 ft on the channel side and backfilled with stone (Figure 74, Sections E and F). Two trunk sections, one 352 ft long and the other 554 ft long, of the north and south piers, respectively, (Figures 73 and 74, Section C) were capped with a stone and concrete superstructure. The crest el of these structures was +7.3 ft lwd.
1951	The south pierhead (Figure 73, Section D1) was repaired.
1953	The north pierhead (Figure 73, Section D2) was repaired.

(Continued)

Table 29 (Concluded)

Date(s)	Construction and Rehabilitation History
1984	A site inspection revealed the north pier to be in very good condition and the south pier to be in fair to poor condition. The south pier had sheeting boards that were deteriorated and loose in some areas and not effectively retaining fill material.
1986	The overall condition of the structures is presently considered fair.



LAKE MICHIGAN

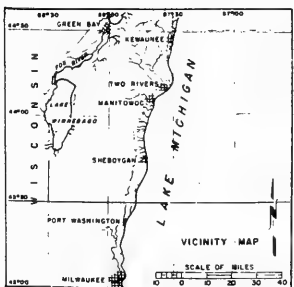


Figure 73. Two Rivers Harbor, Wisconsin



Table 30  
Manitowoc Harbor Breakwaters  
Manitowoc, Wisconsin

<u>Date(s)</u>	<u>Construction and Rehabilitation History</u>
1895	Construction of the lakeward 800-ft portion of the north breakwater (Figure 75, Sections C and D) was completed. The breakwater consisted of stone-filled timber crib construction (Figure 76, Sections C and D). Riprap toe protection was included around the base of the structure.
1907- 1910	The shoreward 1,740-ft portion of the north breakwater and the entire 2,290-ft south breakwater were constructed during this time (Figure 75, Sections A, B, E, F, and F1). The shoreward 1,450- and 1,200-ft lengths of the north and south breakwaters, respectively, (Figures 75 and 76, Sections A and E) were constructed of wood piles and were 14 ft in width. The adjacent 290-ft lengths of breakwater extending lakeward on each structure (Figures 75 and 76, Section B) were constructed of stone and concrete and were also 14 ft in width. The remaining 800 ft of the south breakwater was built of timber cribs filled with stone (Figures 75 and 76, Sections F and F1). They were 24 ft in width. Riprap was placed along each side of the structures for toe protection.
1918	The 100-ft-long north breakwater head (Figures 75 and 76, Section D) was capped with a concrete superstructure. The elevation of the breakwater was +7.1 ft lwd.
1924	The shoreward 1,450-ft-long portion of the north breakwater (Figures 75 and 76, Section A) was capped with a stone and concrete superstructure. The total width of the cap was 17 ft, and the crest el was +7.1 ft lwd.
1925	The shoreward 1,200-ft-long portion of the south breakwater (Figures 75 and 76, Section E) was capped with a stone and concrete superstructure. The total width of the cap was 15 ft, and the crest el was +7.1 ft lwd.
1926	A 700-ft-long portion of the north breakwater (Figures 75 and 76, Section C), and the lakeward 800 ft of the south breakwater (Figures 75 and 76, Sections F and F1) were capped with stone and concrete superstructures. The structures were 24 ft in width with crest els of +7.1 ft lwd.
1933- 1934	The 290-ft-long trunk portions of the north and south breakwater (Figures 75 and 76, Section B) were capped with concrete superstructures with +7.1 ft lwd crest els.

(Continued)

Table 30 (Concluded)

Date(s)	Construction and Rehabilitation History
1948- 1949	A 74-ft-long stone-filled timber crib north pier was constructed in 1948. (Figure 75, Section G). In 1949 the pier was rebuilt by installing steel sheet piles on each side, filling the voids with gravel, and capping the structure with stone (Figure 76, Section G). The pier was 24 ft in width and had a crest el of +7.0 ft lwd.
1951- 1960	A 148-ft-long portion of the south breakwater (Figures 75 and 76, Section Fl) was repaired. Steel sheet piles were installed along each side of the breakwater, and 3-ft-thick precast concrete blocks were placed in the superstructure.
1982	A site inspection made of the structures indicated that the north pier and north breakwater were in good to excellent condition. The shoreward 1,200 ft of the south breakwater was also in good condition; however, the lakeward portions (Sections B, F, and Fl) were in need of repair. Settlement of Section B had occurred, and portions of the concrete cap had deteriorated and required patchwork. Sections F and Fl were in fair to poor condition. Stone fill was required under the concrete cap, and in some areas the cap needed replacement.
1983	Repair of the deficiencies noted during the 1982 site inspection was completed.
1986	The structures are presently in good condition.



HARBOR SIDE

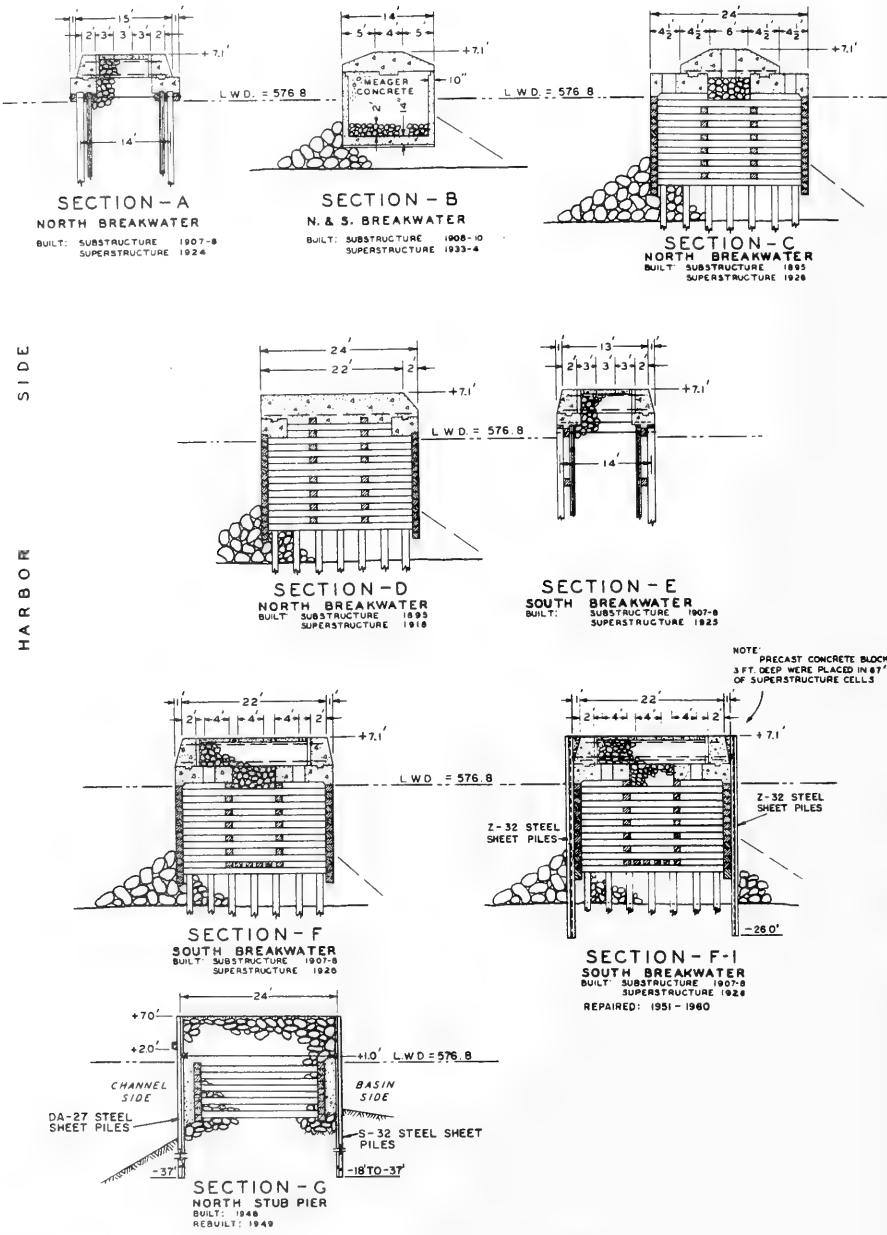


Figure 76. Typical structure cross sections, Manitowoc Harbor, Wisconsin



Table 31  
Sheboygan Harbor Structures  
Sheboygan, Wisconsin

<u>Date(s)</u>	<u>Construction and Rehabilitation History</u>
1873	Construction of an initial 50-ft-long portion of the south pier was completed (Figures 77 and 78, Section J). This was a stone-filled timber crib structure that was 30 ft wide. Riprap toe protection also was provided.
1881- 1882	The original pier was extended 132 ft lakeward (Figures 77 and 78, Section K). The extension consisted of woodpiling installed to form a pier 19 ft in width. The structure was filled with stone. An additional 100-ft lakeward extension was completed during this time (Section L). This was a 20-ft-wide stone-filled timber crib structure with riprap toe protection.
1885- 1893	Another lakeward extension of the pier was completed. This construction entailed a 650-ft-long stone-filled timber crib structure that was 20 ft wide with riprap installed along its base (Figures 77 and 78, Section M).
1895- 1897	Construction of the shoreward 958-ft portion of the south pier was completed during this period (Figures 77 and 78, Section I). It was a 14-ft-wide structure built with woodpiling and a stone fill. Riprap was placed on the lakeside of the pier.
1900	Construction of the lakeward 600-ft portion of the north breakwater was completed (Figures 77 and 79, Sections G and H). The breakwater was built of stone-filled timber cribs 30 ft in width, which included stone along the base on each side of the structure.
1903 1904	Construction of a 120-ft-long north pier (Figures 77 and 78, Section P) and a 600-ft-long extension of the south pier (Figures 77 and 78, Section N) was completed. The north pier was constructed of woodpiling installed 14 ft apart and was stone filled. The south pier extension was a stone-filled timber crib structure. It was 24 ft wide and included stone toe protection.
1908	A 196-ft-long shoreward extension of the north breakwater was constructed (Figures 77 and 79, Section F). The structure was of stone-filled timber crib construction and was 30 ft in width with stone installed on each side of its base.
1913- 1915	Construction of the shoreward 3,037-ft portion of the north breakwater was completed (Figures 77 and 79, Sections A, B, Bl, C, D, and E). The structure was built with wood piles and filled with stone, and the width of the structure varied from 11 to 20 ft. The breakwater was also capped with a concrete superstructure at a crest

(Continued)

Table 31 (Concluded)

Date(s)	Construction and Rehabilitation History
	el of +7.1 ft lwd, and riprap was installed on both sides of the structure. The 100-ft-long lakeward end of the north breakwater (Section H) was also capped with a concrete superstructure in 1915.
1918	The north pier was capped with a concrete superstructure with a crest el of +7.3 ft lwd (Figure 78, Section P).
1925- 1926	A concrete and stone superstructure was installed on 1,250 ft of the south pier (Figures 77 and 78, Sections M and N) and 696 ft of the north breakwater (Figures 77 and 79, Sections F and G). The crest el of these structures was +7.1 ft lwd.
1933	A stone and concrete superstructure was installed on the shoreward 1,240 ft of the south pier (Figures 77 and 78, Sections J, K, L, and I). The widths of the superstructure ranged from 15 to 20 ft, and the crest el was +7.1 ft lwd.
1963	A 1,728-ft-long portion of the north breakwater was repaired (Figure 77, Sections C, D, and E).
1964	The 958-ft-long shoreward end of the south pier was repaired (Figure 77, Section I), and the north pier was rebuilt (Figures 77 and 78, Section p). Steel sheet piles were driven on each side of the existing north pier forming a width of 23 ft. The voids were filled with stone and concrete to an el of +7.3 ft lwd. An 843-ft-long portion of the north breakwater also was repaired during this year (Figures 77 and 79, Sections B and B1). Riprap was installed to the el of the superstructure (+7.1 ft lwd) on both sides of Section B with 1-V:1.5-H side slopes. Stone was installed over Section B1 to an el of +6.75 ft lwd. The crest was 20 ft wide, and the stone was grouted in place. Side slopes were 1V:1.5H.
1980	Toe stone was placed along the outermost section of the south pier (Figure 77, Section N) to stabilize settling of the structure. Concrete repair work was completed on the north pier.
1984	A site inspection of the south pier indicated the channel side of the structure was in good condition. Fill rock was needed, however, in some areas, and the concrete cap was leaning toward the channel in one area.
1986	The structures presently are considered to be in good condition overall.

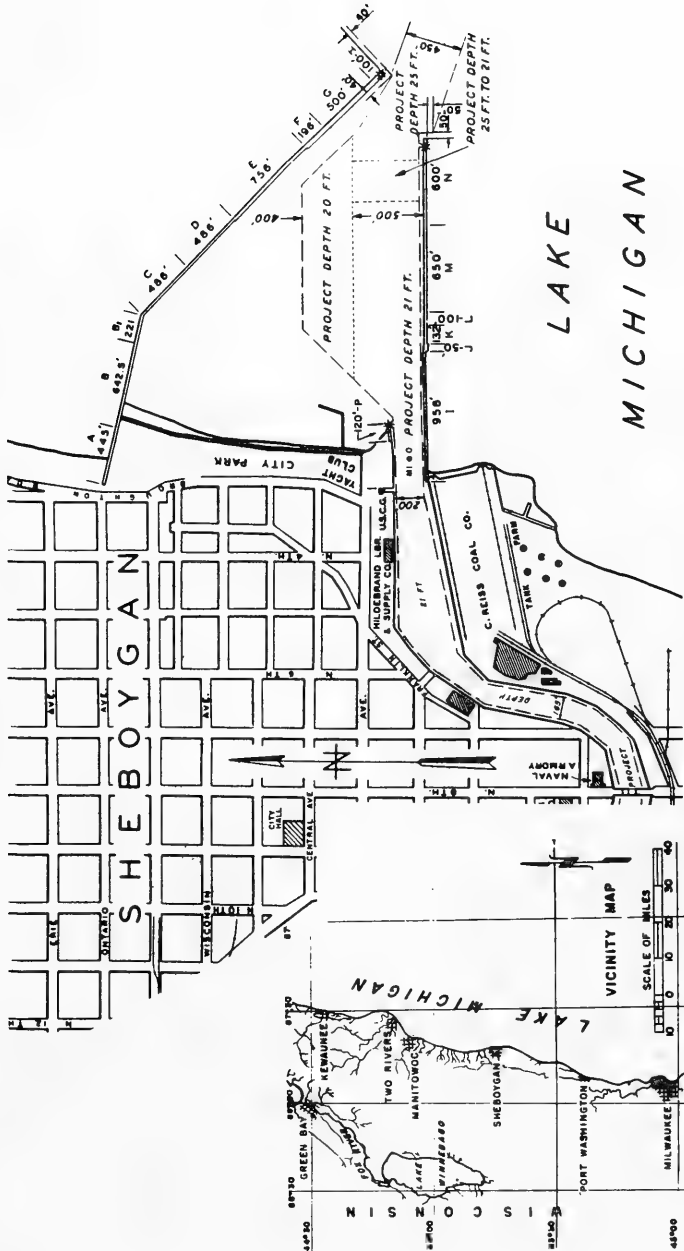
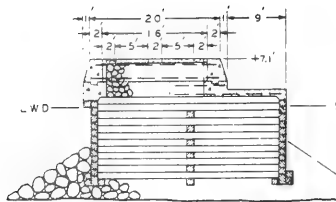
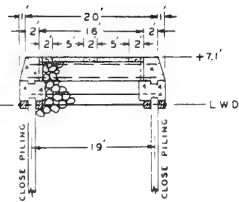


Figure 77. Sheboygan Harbor, Wisconsin

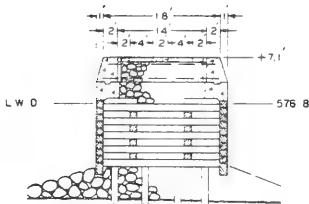
CHANNEL OR HARBOR SIDE



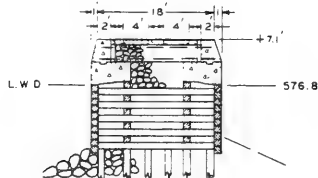
**SECTION - J**  
SOUTH PIER  
BUILT: SUBSTRUCTURE 1873  
SUPERSTRUCTURE 1933



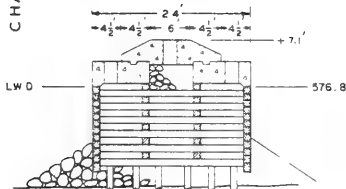
**SECTION - K**  
SOUTH PIER  
BUILT: SUBSTRUCTURE 1881-2  
SUPERSTRUCTURE 1933



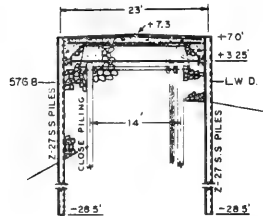
**SECTION - L**  
SOUTH PIER  
BUILT: SUBSTRUCTURE 1882  
SUPERSTRUCTURE 1933



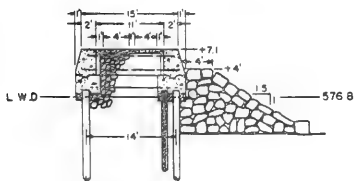
**SECTION - M**  
SOUTH PIER  
BUILT: SUBSTRUCTURE 1885, 89, 93  
SUPERSTRUCTURE 1923-8



**SECTION - N**  
SOUTH PIER  
BUILT: SUBSTRUCTURE 1903-4  
SUPERSTRUCTURE 1926



**SECTION - P**  
NORTH STUB PIER  
BUILT: SUBSTRUCTURE 1903-4  
SUPERSTRUCTURE 1918  
REBUILT 1964



**SECTION - I**  
SOUTH PIER  
BUILT: SUBSTRUCTURE 1895-7  
SUPERSTRUCTURE 1933, REPAIRED; 1964

Figure 78. Typical pier cross sections, Sheboygan Harbor, Wisconsin

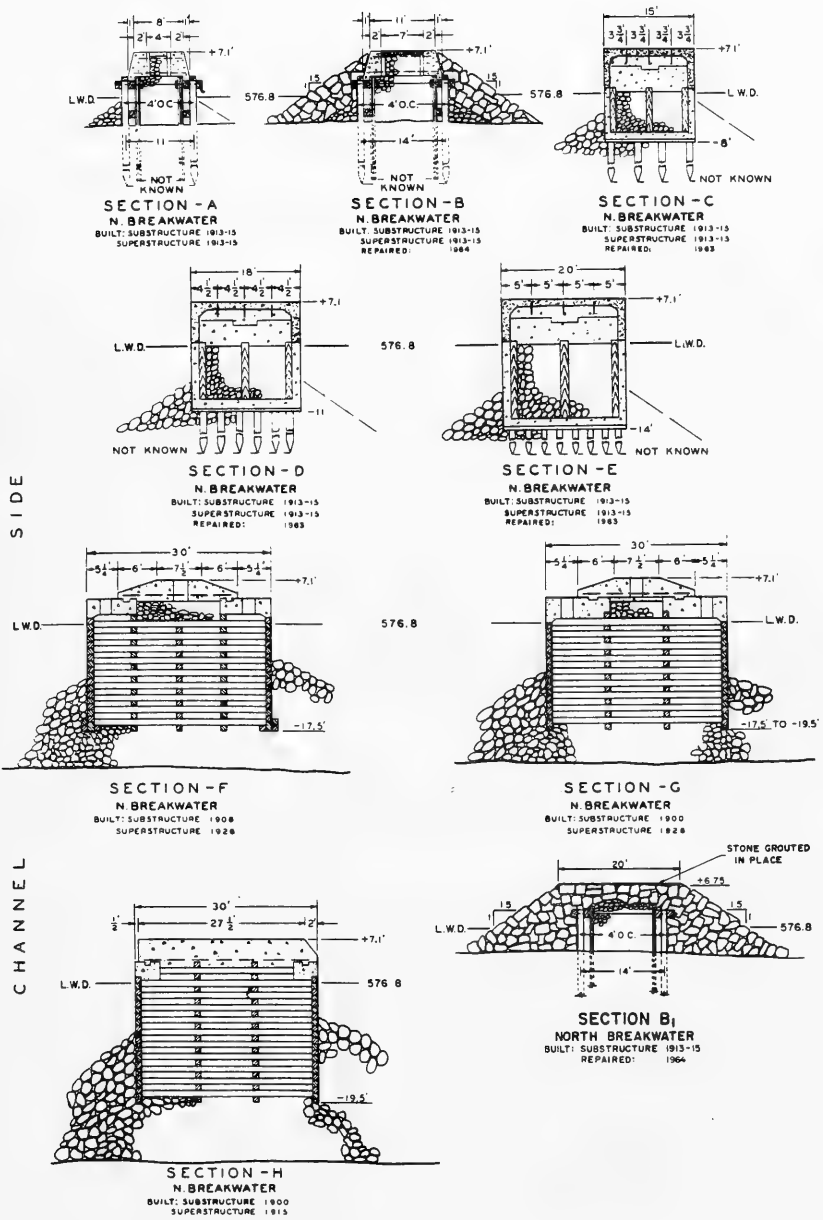


Figure 79. Typical structure cross sections, Sheboygan Harbor, Wisconsin

Table 32

Port Washington Harbor StructuresPort Washington, Wisconsin

Date(s)	Construction and Rehabilitation History
1934	Construction of a 2,537-ft-long north breakwater was completed (Figure 80, Sections A-E). The shoreward portion of the breakwater was composed of single-wall steel sheet piles installed at an el of +7.0 ft lwd with riprap placed on both sides to a 0.0-ft lwd el (Figure 81, Section E). The next lakeward 990-ft-long portion of the north breakwater (Section D) was constructed on stone-filled cellular sheet-pile structures (arch cell type). Capstone was grouted in place at an el of +7.5 ft lwd. The structure ranged from about 14 ft in width to over 22 ft. Riprap was placed along both sides of the structure (Figure 81, Section D). The lakeward portion of the breakwater consisted of a concrete superstructure on a rubble-mound base (Figure 81, Sections A, B, and C). The width of the superstructure was 6.2 ft, and the crest el was +8.0 ft lwd. The rubble-mound portion had side slopes of 1V:1.5H. The outer 54 ft of the north breakwater consisted of two rectangular caissons.
1936	Construction of the 1,006-ft-long south breakwater was completed (Figure 80, Sections A, I, and J). The lakeward 392.5-ft portion of the breakwater consisted of a concrete superstructure on a rubble-mound base similar to the outer end of the north breakwater (Figure 81, Section A). The remaining structure was of rubble-mound construction with a crest el of +8.0 ft lwd and a crest width ranging from 6 to 7 ft. Side slopes were constructed 1V:1.5H (Figure 82, Sections I and J).
1940	Construction of the north pier was completed (Figure 80, Sections F and G). The structure included timber cribs with woodpiling on the channel side with an el of +8.0 ft lwd (Figure 82, Sections F and G). The structure was capped with sand and earth fill (Section F) and stone fill (Section G).
1950	Because storm waves caused damage to harbor facilities and because of difficulties to navigation since breakwater construction, the harbor was modeled (Fortson 1951). Model tests for improving wave conditions involved placement of rubble-wave absorbers at critical locations in slips, placement of rubble on the lakeside of the north and south breakwaters, construction of a small-boat basin for pleasure craft, and extension of the lakeward end of the north breakwater.
1976	Model tests involving the use of Igloo wave absorber units (Bottin 1976) were conducted to determine if wave heights in the inner slip areas of the harbor could be significantly reduced, if the Igloos could be substituted for rubble-mound structures in the proposed small-boat harbor, and if the absorbed units could be used as an alternative to rubble absorbers proposed for the small-boat harbor.

(Continued)

Table 32 (Concluded)

Date(s)	Construction and Rehabilitation History
1980	A site inspection of the structures indicated that they were in good condition but required minor repair in the form of a finishing touch on the grouted cap to improve their appearance. The work was subsequently completely.
1982	Construction of breakwaters and other improvements within the existing harbor was completed (Figure 83). A 725-ft-long west breakwater, a 320-ft-long east breakwater, an absorber, and a parapet wall were installed. The east and west breakwaters were rubble-mound structures with a 12-ft-wide crest width covered with 4.2-ton armor (Figure 84). Side slopes were 1V:1.5H. The crest el of the west breakwater was +8 ft lwd, and steel sheet pile was included to make the structure impervious. The east breakwater had a crest el of +12 ft lwd. An absorber and a parapet wall were installed along the existing north breakwater adjacent to the harbor (Figure 84). The absorber, installed at an el of +4 ft lwd, was comprised of 2-ton cover stone. The crest el of the parapet was +7 ft lwd. The improvements were model tested (Bottin 1977) prior to construction.
1986	The structures presently are in good condition.

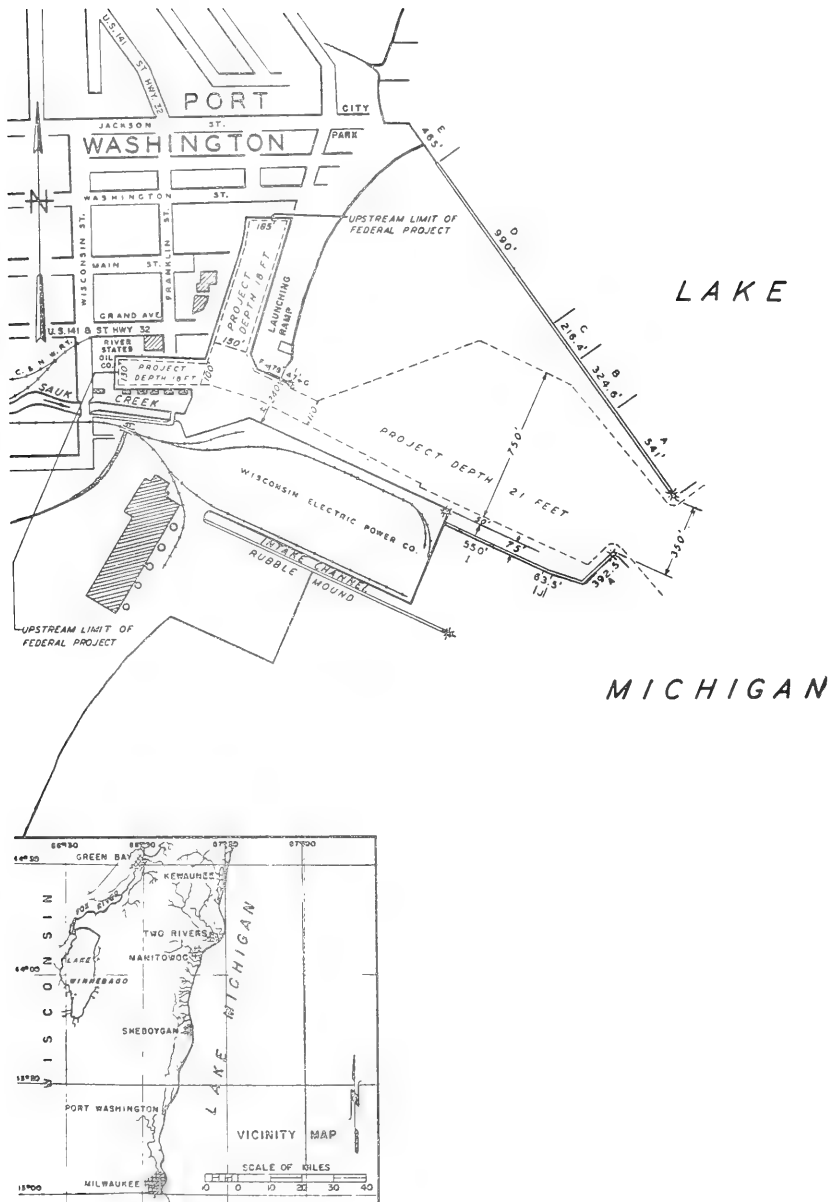
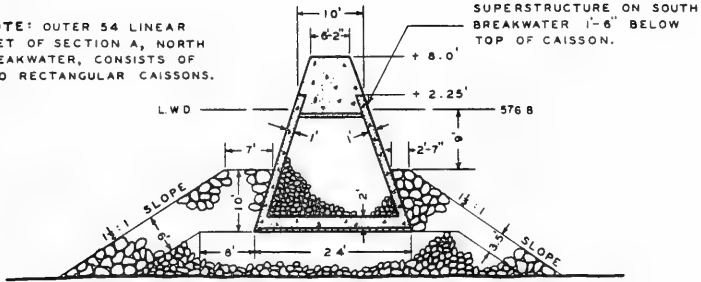


Figure 80. Port Washington Harbor, Wisconsin



NOTE: OUTER 54 LINEAR FEET OF SECTION A, NORTH BREAKWATER, CONSISTS OF TWO RECTANGULAR CAISSONS.

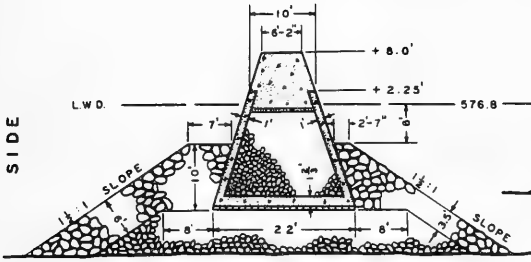


SECTION-A

NORTH & SOUTH BREAKWATER

BUILT SUBSTRUCTURE 1926 1936  
SUPERSTRUCTURE 1934 1938

SIDE

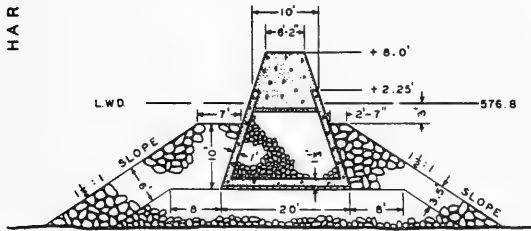


SECTION-B

NORTH BREAKWATER

BUILT SUBSTRUCTURE 1934  
SUPERSTRUCTURE 1934

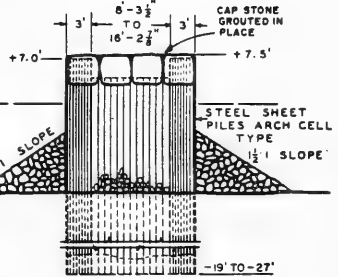
HARBOR



SECTION-C

NORTH BREAKWATER

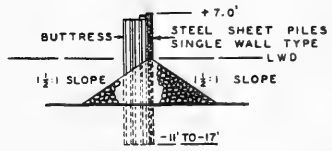
BUILT SUBSTRUCTURE 1934  
SUPERSTRUCTURE 1934



SECTION-D

NORTH BREAKWATER

BUILT: 1934



SECTION-E

NORTH SHORE CONNECTION

BUILT: 1934

Figure 81. Typical breakwater cross sections, Port Washington Harbor, Wisconsin

CHANNEL OR HARBOR SIDE

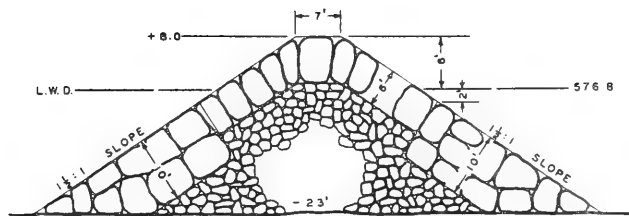
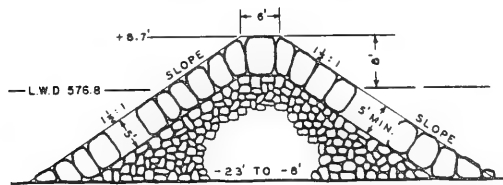
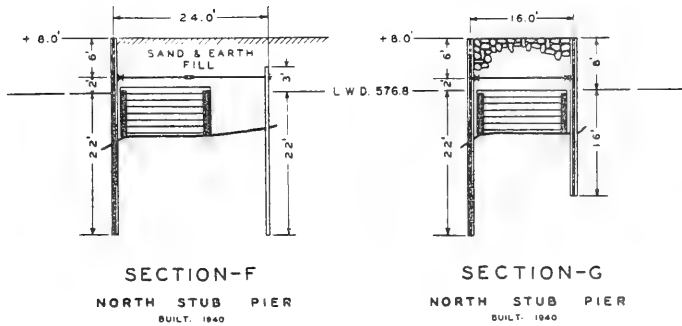


Figure 82. Typical structure cross sections, Port Washington Harbor, Wisconsin

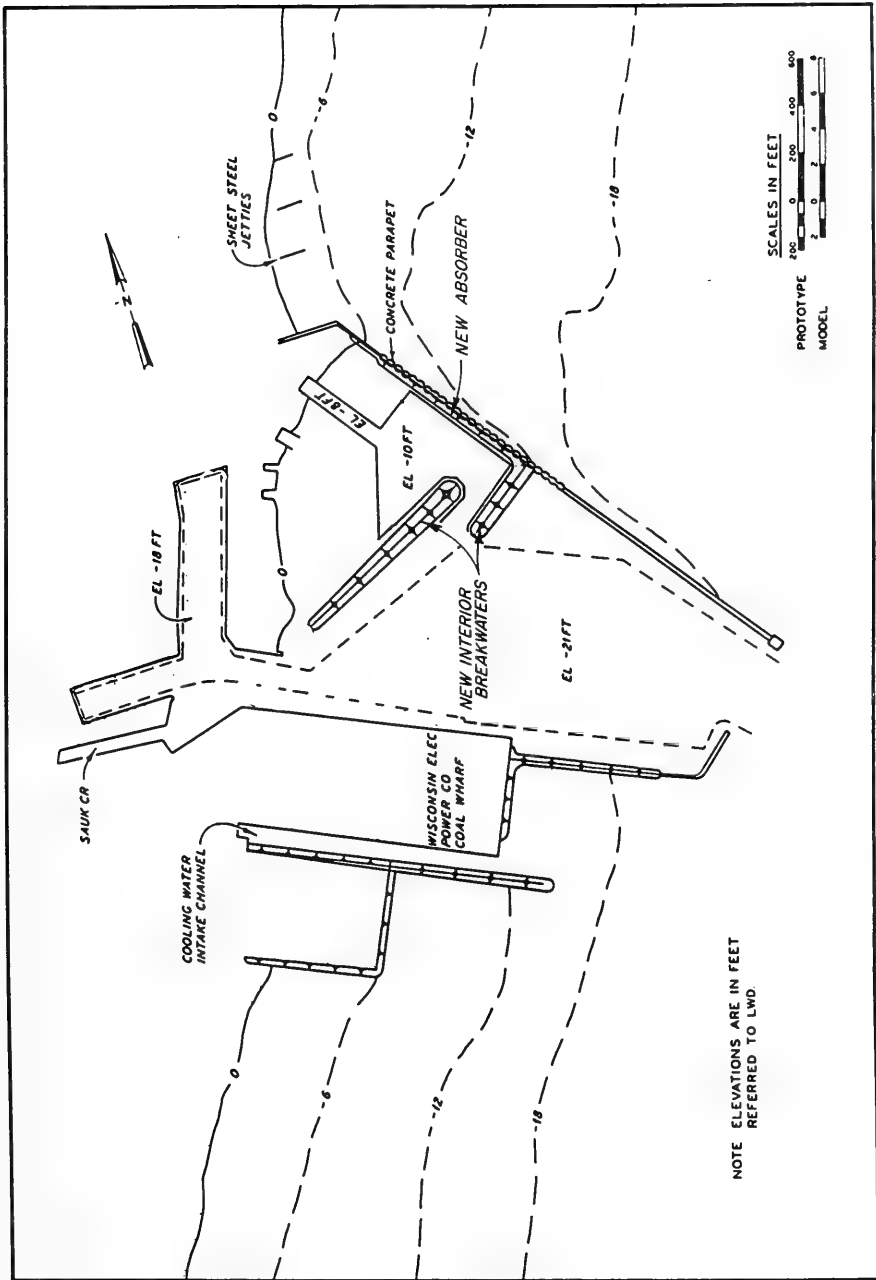
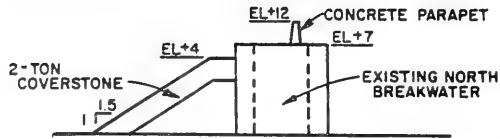
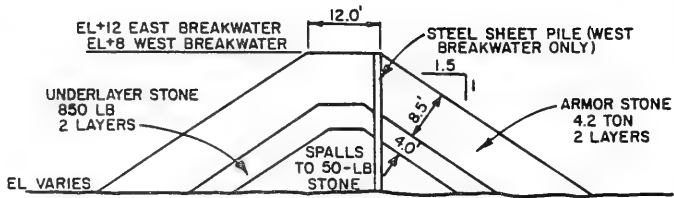


Figure 83. Improvements for small-boat harbor at Port Washington, Wisconsin



MODIFICATIONS TO NORTH BREAKWATER  
ADJACENT TO NEW HARBOR

SCALE IN FEET



NEW EAST AND WEST  
INTERIOR BREAKWATERS

SCALE IN FEET



Figure 84. Cross sections of small-boat harbor structures at Port Washington, Wisconsin

Table 33  
Milwaukee Harbor Structures  
Milwaukee, Wisconsin

Date(s)	Construction and Rehabilitation History
1855- 1866	Construction of a 1,056-ft-long north pier at the entrance (Figure 85) progressed during this period. The pier was a stone-filled timber crib structure and was 24 ft in width (Figure 86, Section F).
1868- 1869	A 250-ft lakeward extension of the north pier was completed (Figure 86, Section G). The extension was a stone-filled timber crib structure that was 28 ft in width.
1871	An additional 200-ft extension of the north pier was constructed (Figure 86, Section H). The extension was also a stone-filled timber crib structure with a total width of 33.5 ft.
1881- 1893	Construction of the shore-connected portion of the north breakwater was completed during this time (Figure 85). The breakwater was built with stone-filled timber cribs. The outer 1,756 ft was built on a stone foundation, and the width of the structure ranged from about 20 to 32 ft (Figure 87, Sections A, B', B'-1, B-2, and B-5). Riprap was placed along the base of most of the remaining structure.
1888- 1899	Construction of the northern 3,780 ft of the detached portion of the north breakwater was completed during this period (Figure 87, Sections B'-3, C, and C-1). The structures were also built with stone-filled timber cribs and ranged from 23 to 30 ft in width. Riprap was placed along the base of the structure.
1903- 1906	During this time the north pier was extended an additional 150 ft (Figure 86, Section I). The extension was a 28-ft-wide stone-filled timber crib structure built on woodpilings with riprap installed along the base on each side. The entire north pier was capped with a concrete superstructure. The shoreward 1,056 ft (Section F) had a crest el of +9.0 ft lwd, and the remaining portion of the structure (Sections G, H, and I) had an el of +11.5 ft lwd. The shore-connected portion of the north breakwater was capped with a concrete superstructure (Figure 87, Sections A, B', B'1, B2, and B5). The shoreward 1,472-ft length (Sections A and B5) also included a 3-ft-wide concrete parapet wall at an el of +11.4 ft lwd. The remaining portion of the breakwater (Sections B' and B'-1) had a crest el of +8.1 ft lwd. the 450-ft-long outer end (Section B'-1) had riprap installed on each side of the structure. The el of the stone was +3. ft lwd, and it had side slopes of 1V:1.5H.
1907- 1910	The detached portion of the north breakwater was extended southerly by 980 ft (Figure 87, Section D). The extension was constructed of stone-filled timber cribs and was 30 ft in width. The existing detached portion of the north breakwater at this point (Figure 87, Sections B'-3, C, and C-1) was capped with a concrete superstructure, which resulted in a crest el of +8.2 ft lwd.

(Continued)

Table 33 (Concluded)

Date(s)	Construction and Rehabilitation History
1909- 1910	A 216-ft-long south pier extension was constructed (Figure 86, Section L). The pier was a stone-filled concrete structure built on woodpilings and stone. It was 18 ft in width and had a crest el of +8.1 ft lwd.
1923- 1924	A 980-ft portion of the detached north breakwater was capped with a concrete superstructure (Figure 87, Section D). The crest el of the structure was +8.6 ft lwd.
1924- 1929	Construction of the southerly 1,744-ft portion of the north breakwater and the entire south breakwater (Figure 87, Section E) was completed during this time. The breakwater was a stone-filled concrete structure built on stone. It had a crest width of 6.7 ft and an el of +8.6 ft lwd. The outer 54 ft of the north breakwater consisted of three rectangular caissons.
1950- 1952	A 530-ft-long section of the attached north breakwater (Figure 87, Section B5) and a 68-ft-long portion (Section B2) were repaired. Steel sheet piles were driven on both sides of the existing timber crib structure.
1953	The 1,385-ft-long south pier was constructed by the City of Milwaukee (Figure 86, Section J). It consisted of steel sheet piles on the channel side which were backfilled with earth. The existing pier (time of construction unknown) was completely covered by the new structure.
1957- 1959	A 1,940-ft-long portion of the north breakwater was repaired (Figure 87, Section B'-3 and C-1). Steel sheetpiling was driven adjacent to both sides of the timber crib structure.
1962- 1964	A 1,840-ft-long portion of the north breakwater (Figure 87, Section C) was repaired. Steel sheet piles were installed on each side of the existing timber crib.
1976- 1977	A portion of the north breakwater was rebuilt (Figure 87, Section B5). Steel sheet piles were installed on each side of the existing structure with the width varying from 30 to 32.5 ft. The voids were filled with stone, and the concrete cap and parapet wall were reconstructed. A parapet wall also was installed on an adjacent portion of the breakwater (Section B2).
1984	A site inspection of the north breakwater revealed some sections in good shape and others requiring repair and maintenance.
1985	Repair of the head of the south breakwater was completed for a cost of \$810,942. A new caisson was constructed and capped with concrete. Stone, ranging from 3 to 6 tons, was placed around the new caisson for toe protection.
1986	The breakwaters and piers are presently considered to be in fair condition.

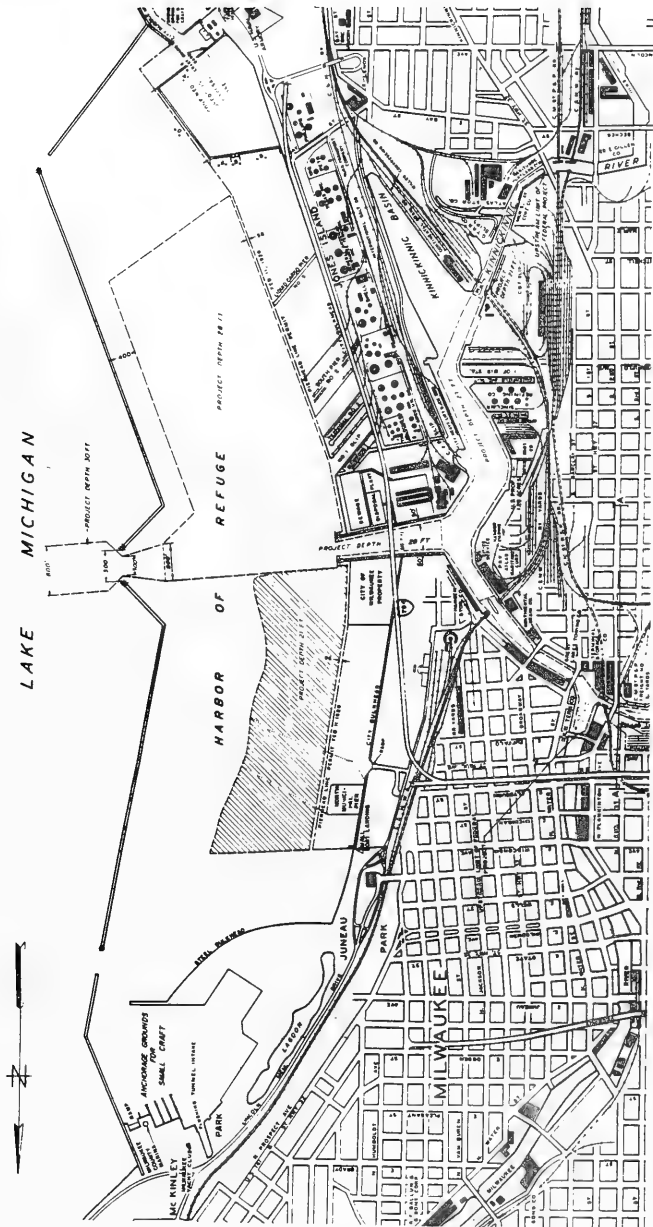
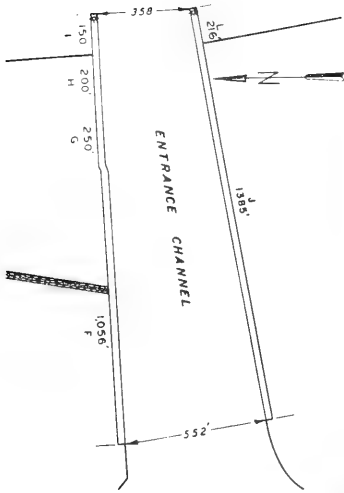
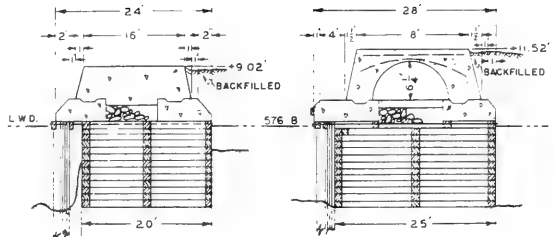


Figure 85. Milwaukee Harbor, Wisconsin

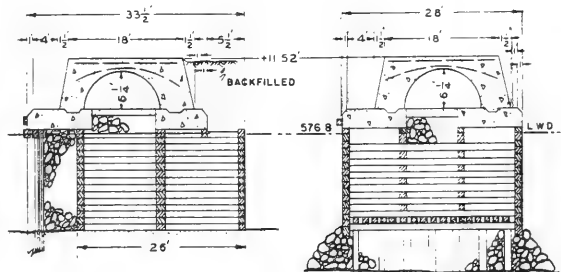


ENTRANCE PIERS  
SCALE OF FEET  
100 0 100 300 500



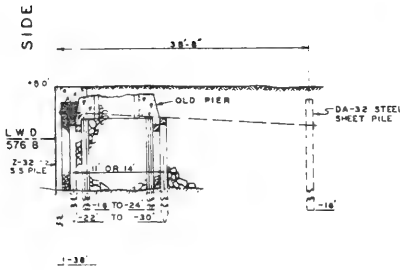
SECTION - F  
NORTH PIER  
BUILT SUBSTRUCTURE 1855-88  
SUPERSTRUCTURE 1903-4

SECTION - G  
NORTH PIER  
BUILT SUBSTRUCTURE 1868-9  
SUPERSTRUCTURE 1905-8

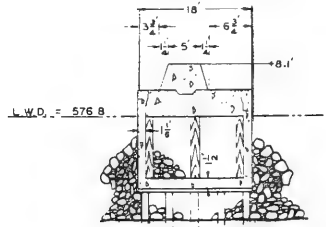


SECTION - H  
NORTH PIER  
BUILT SUBSTRUCTURE 1871  
SUPERSTRUCTURE 1905-6

SECTION - I  
NORTH PIER  
BUILT SUBSTRUCTURE 1905  
SUPERSTRUCTURE 1903-8



SECTION - J  
SOUTH PIER  
BUILT: 1953 BY CITY  
OF MILWAUKEE



SECTION - L  
SOUTH PIER  
BUILT: SUBSTRUCTURE 1908-10  
SUPERSTRUCTURE 1908-10

CHANNEL

Figure 86. Typical pier cross sections, Milwaukee Harbor, Wisconsin



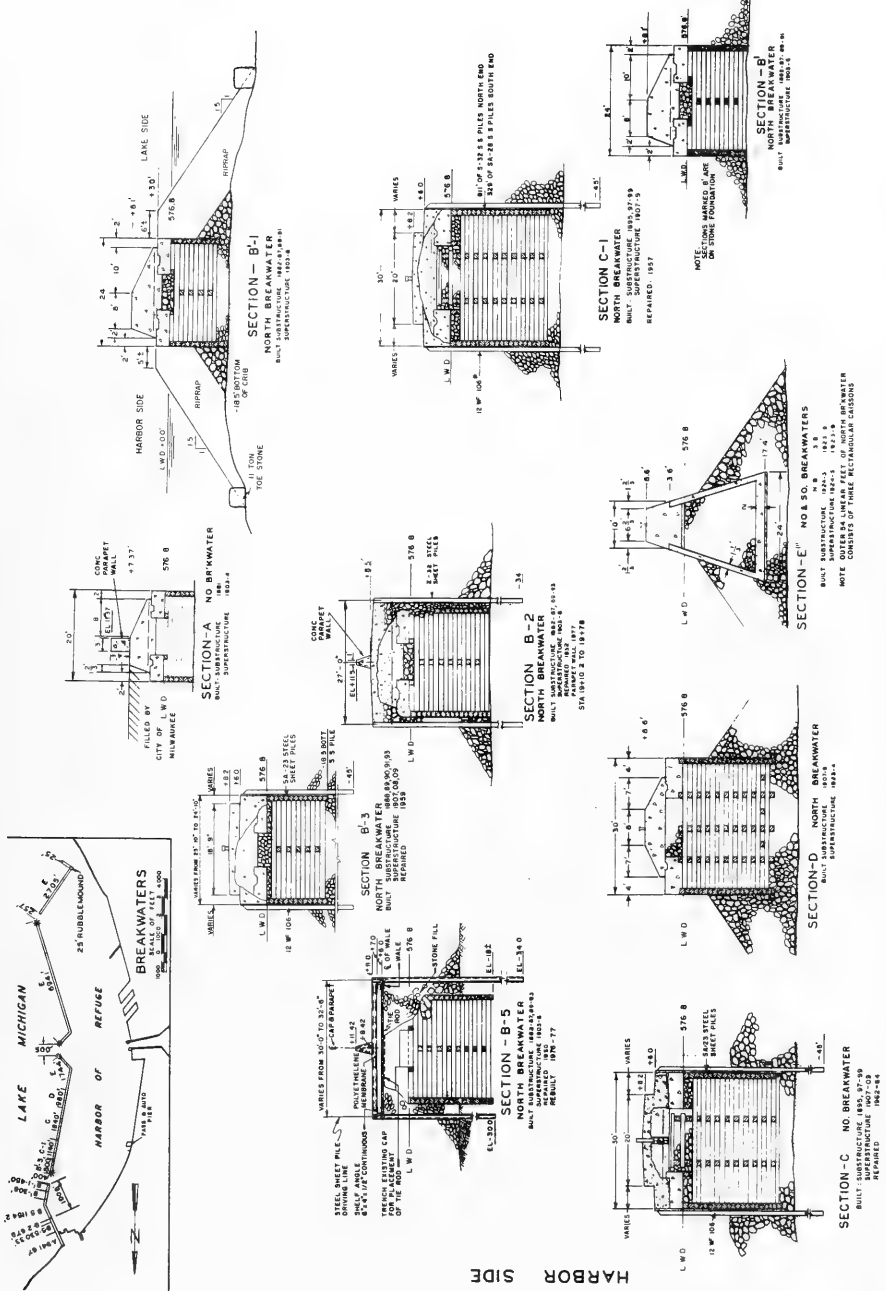


Table 34

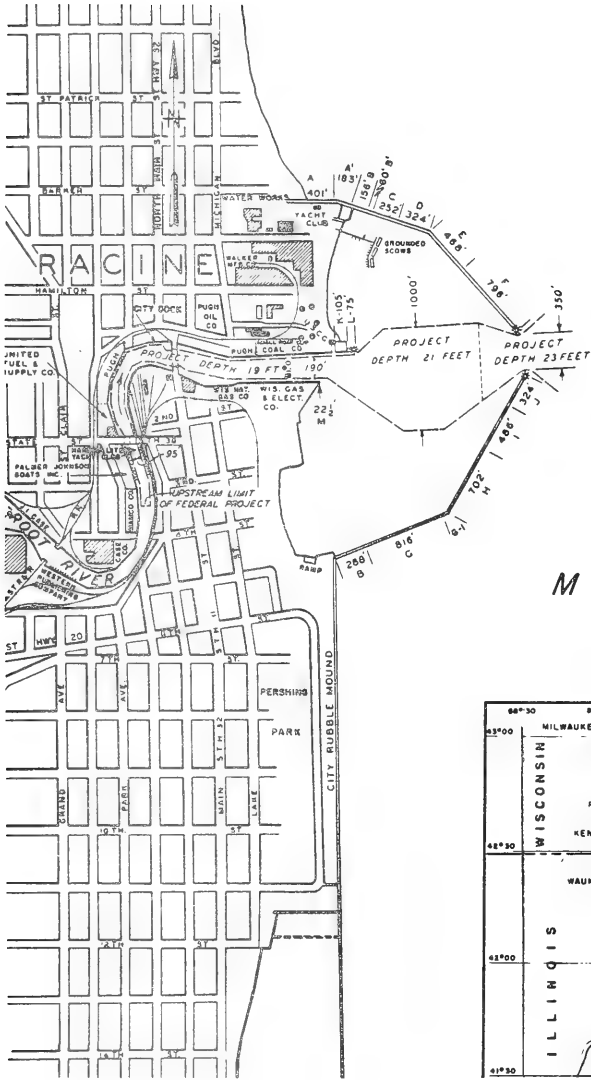
Racine Harbor StructuresRacine, Wisconsin

Date(s)	Construction and Rehabilitation History
1900	Construction of the 796-ft-long outer portion of the north breakwater (Figure 88, Section F) was completed. The breakwater was a stone-filled timber crib structure (Figure 89, Section F). It was 30 ft wide, and riprap toe protection was placed on each side.
1912- 1913	Construction of the 1,844-ft shoreward portion of the north breakwater was completed during this time (Figure 88, Sections A, A', B, B', C, D, and E). The shoreward 800 ft of the structure (Figures 89 and 90, Sections A, A', B, and B') were constructed with woodpilings driven from 11 to 14 ft apart and stone filled. The breakwater was capped with a stone and concrete superstructure installed at an el of +7.1 ft lwd. Riprap toe protection was placed on both sides of the breakwater. The adjacent 1,044 ft of breakwater extending lakeward (Figure 89, Sections C, D, and E) was constructed of a stone-filled concrete structure built on wood piles. The crest el of the breakwater was +7.1 ft lwd, and the crest width ranged from 15 to 20 ft. Riprap toe protection also was installed on both sides of the breakwater.
1917- 1919	Construction of the 1,512-ft-long lakeward portion of the south breakwater (Figure 88, Sections H, I, and J) was completed during this period. The breakwater consisted of a concrete superstructure built on stone. The superstructure was either sand or stone filled (Figure 89, Sections H, I, and J). The crest el of the structure was +7.1 ft lwd, and it had a 10-ft crest width. The outer portion of the structure (Section J) was covered with riprap ranging from 6 to 16 tons (9-ton average) to an el of +4 ft lwd. The slope of the riprap was 1V:1.5H.
1924	Construction of the shoreward 1,104-ft-long portion of the south breakwater (Figure 88, Sections B and G) and the south pier (Section M) was completed. The breakwater was constructed with a stone-filled concrete superstructure built on woodpilings (Figure 89, Sections B and G). The pilings were 14 ft (Section B) or 17 ft (Section G) apart. Riprap toe protection was included on both sides of the breakwater. The north pier also consisted of a stone-filled concrete superstructure built on woodpilings that were spaced 15.5 ft apart (Figure 89, Section M). The crest el of both the breakwater and pier built during this time was +7.1 ft lwd.
1925	The lakeward portion of the north breakwater (Figure 88, Section F) was capped with a concrete superstructure. The crest el of the structure was +7.1 ft lwd (Figure 88, Section F).

(Continued)

Table 34 (Concluded)

Date(s)	Construction and Rehabilitation History
1940	Construction of the north pier (Figure 88, Sections K and L) was completed. The inner 105-ft-long portion was a timber crib structure with a sand cap. It was 24.5 ft wide and had a crest el of +7.5 ft lwd (Figure 89, Section K). The outer 75 ft of the pier (Section L) was a wood-pile structure that was 19.5 ft in width and +7.5 ft lwd in height. It was capped with stone.
1959	A 252-ft-long portion of the north breakwater was repaired (Figure 88, Section C).
1966	A 50-ft-long portion of the south breakwater was constructed (Figure 88, Section G-1). The breakwater was built with stone and had a 14-ft-width crest with an el of +7.1 ft lwd. Side slopes were 1V:1.5H. The stone along the crest was grouted in place.
1971	The shoreward 1,104 ft of the south breakwater (Figure 88, Sections B and G) were repaired, and riprap was installed on each side of the structure to an el of +4 ft lwd (Figure 89, Sections B and G). Side slopes of the riprap were 1V:1.5H.
1973	The lakeward 796-ft-long portion of the north breakwater was repaired (Figure 88, Section F). Riprap was installed on each side of the structure (Figure 89, Section F) to an el of +4 ft lwd. The riprap was placed with side slopes of 1V:1.5H.
1974	Two sections of the north breakwater (Figure 88, Sections A' and B') were rebuilt. Steel sheetpiling was driven on the lakeward side of the 183-ft-long portion of Section A' (Figure 90). Filling the voids with stone and capping the breakwater with concrete resulted in a breakwater section that was 17.5 ft in width with a crest el of +7.5 ft lwd. The 60-ft-long portion of Section B' (Figure 90) was covered with stone. It had a 15-ft-wide crest with an el of +7.1 ft lwd. Concrete was poured between the stones on the crest to form a walking surface. The existing concrete superstructure was removed because of its deteriorated condition prior to placement of the stone. Side slopes of the structure were 1V:1.5H.
1986	The structures have undergone repair and maintenance during their lifetime; however, they are presently in good condition. The President signed an act to deauthorize the project at Racine, and the title to any facilities constructed by the United States has been transferred, without consideration, to Racine County.



LAKE  
MICHIGAN

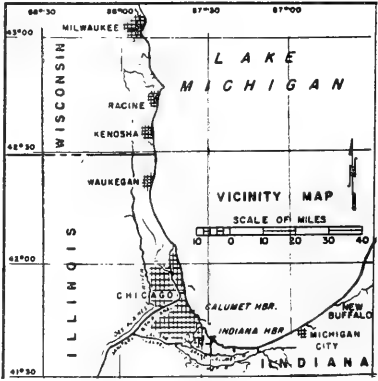


Figure 88. Racine Harbor, Wisconsin

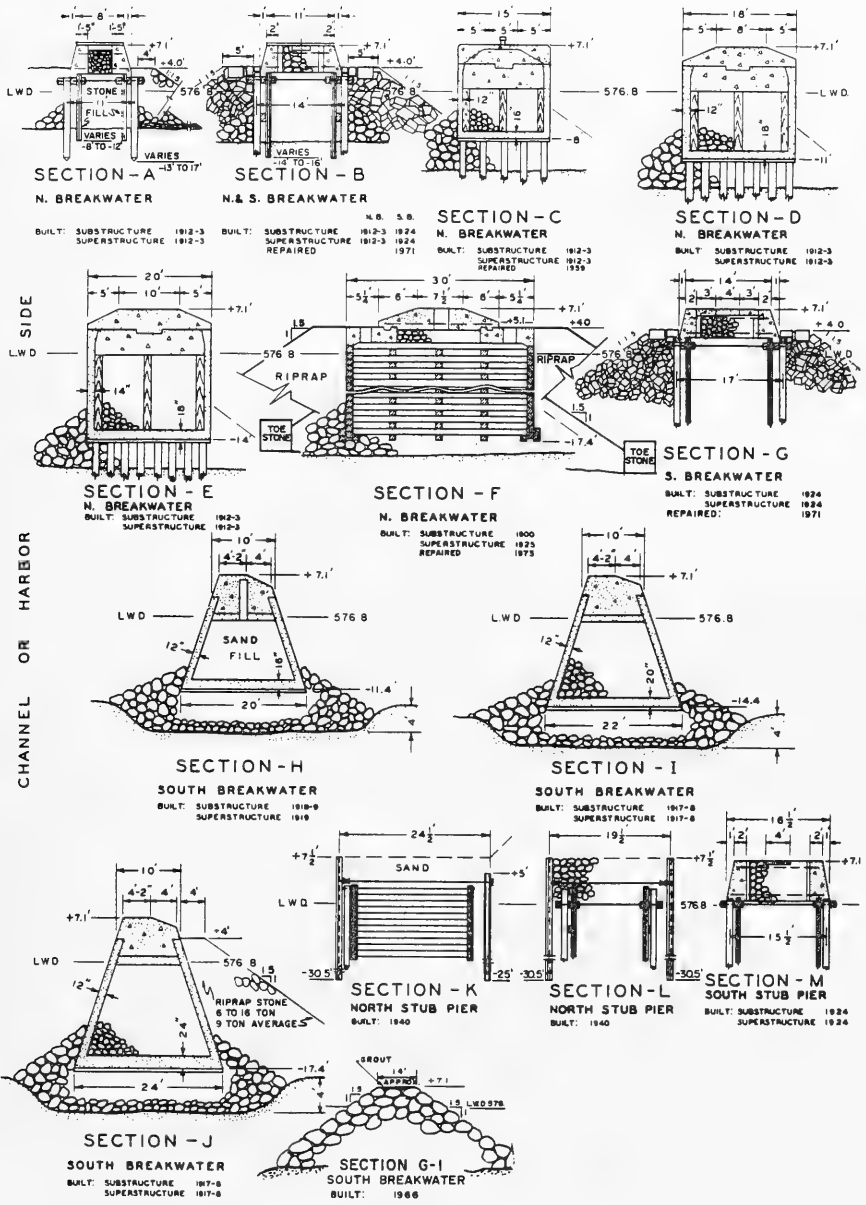
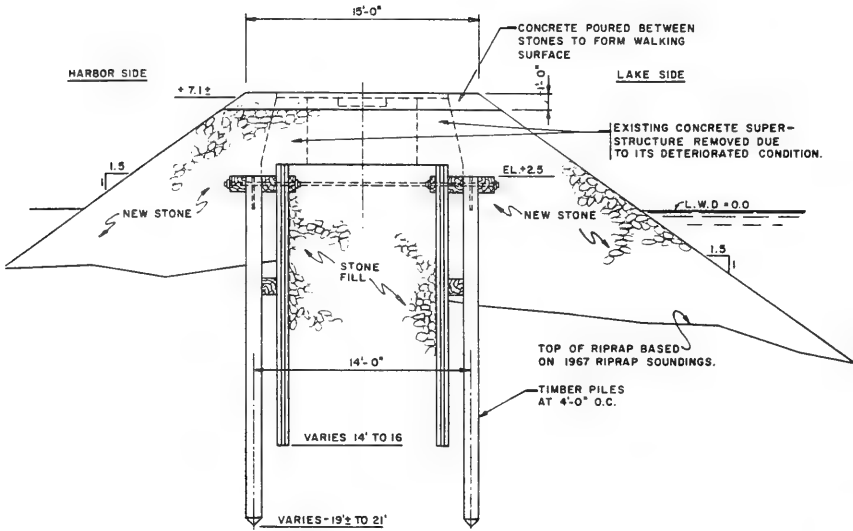
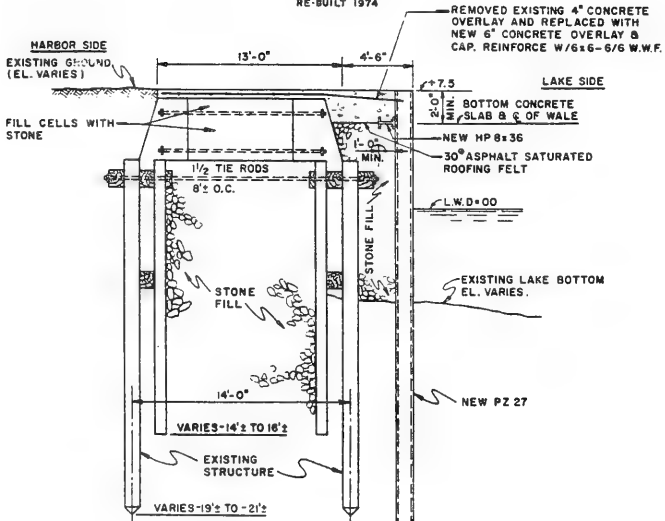


Figure 89. Typical breakwater and pier cross sections, Racine Harbor, Wisconsin



**SECTION - B'**

BUILT: SUB-STRUCTURE 1912-13  
 SUPER-STRUCTURE 1912-13  
 RE-BUILT 1974



**SECTION - A'**

BUILT: SUB-STRUCTURE 1912-13  
 SUPER-STRUCTURE 1912-13  
 RE-BUILT 1974

Figure 90. Typical structure cross sections, Racine Harbor, Wisconsin

Table 35

Kenosha Harbor StructuresKenosha, Wisconsin

<u>Date(s)</u>	<u>Construction and Rehabilitation History</u>
1899- 1900	Construction of a 1,077-ft-long portion north pier, a 1,175-ft-long south pier, and a 796-ft-long offshore breakwater was completed (Figure 91). The shoreward 927 ft of the north pier consisted of a wood-pile structure with widths of 14 ft (Figure 92, Section A) and 18 ft (Section B). The outer 150-ft-long portion of the north pier (Figure 92, Section C), the south pier (Figure 92, Section E), and the offshore breakwater (Figure 92, Section H) were stone-filled timber crib structures. Riprap toe protection was installed on each side of the timber cribs.
1916	Stone and concrete superstructures were constructed on the north and south piers to an el of +6.8 ft lwd (Figure 92, Sections A, B, C, and E).
1923	A stone and concrete superstructure was built on the detached breakwater (Figure 92, Section H) to a crest el of +7.1 ft lwd. The structure was 30 ft wide.
1969- 1970	The north and south piers were rehabilitated during this time (Figure 92, Sections A, B, C, and E). Steel sheetpiling was driven on each side of the north pier resulting in a structure 30 ft wide. Voids were filled with stone, and a concrete cap was installed at a crest el of +8.5 ft. Riprap was installed on each side of the structure. Steel sheetpiling was installed on the lakeward side of the south pier. The void and the existing pier were filled with 50-lb stone. A parapet wall was installed on the lakeward side of the structure to an el of +10 ft lwd. (This was adjacent to a confined dredging disposal area).
1977	The detached breakwater (Figure 92, Section H) was rebuilt, and 1- to 6-ton (3-ton average) riprap stone was placed on each side of the structure to an el of +4 ft lwd. Side slopes of the riprap were 1V:1.5H.
1980	A site inspection of the structures revealed them to be generally in good condition. Spalling of concrete was noted in several areas; however, the problem was not critical at that time.
1986	The structures presently are considered to be in fair condition.



Figure 91. Kenosha Harbor, Wisconsin



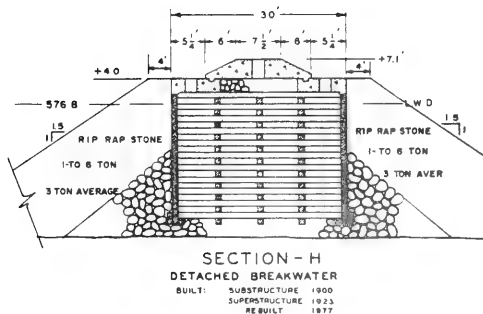
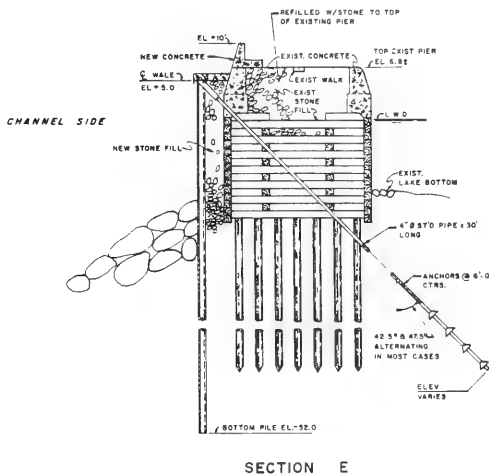
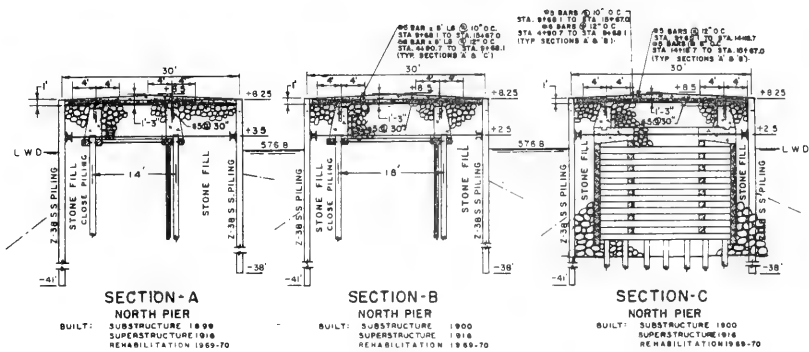


Figure 92. Typical structure cross sections, Kenosha Harbor, Wisconsin

Table 36

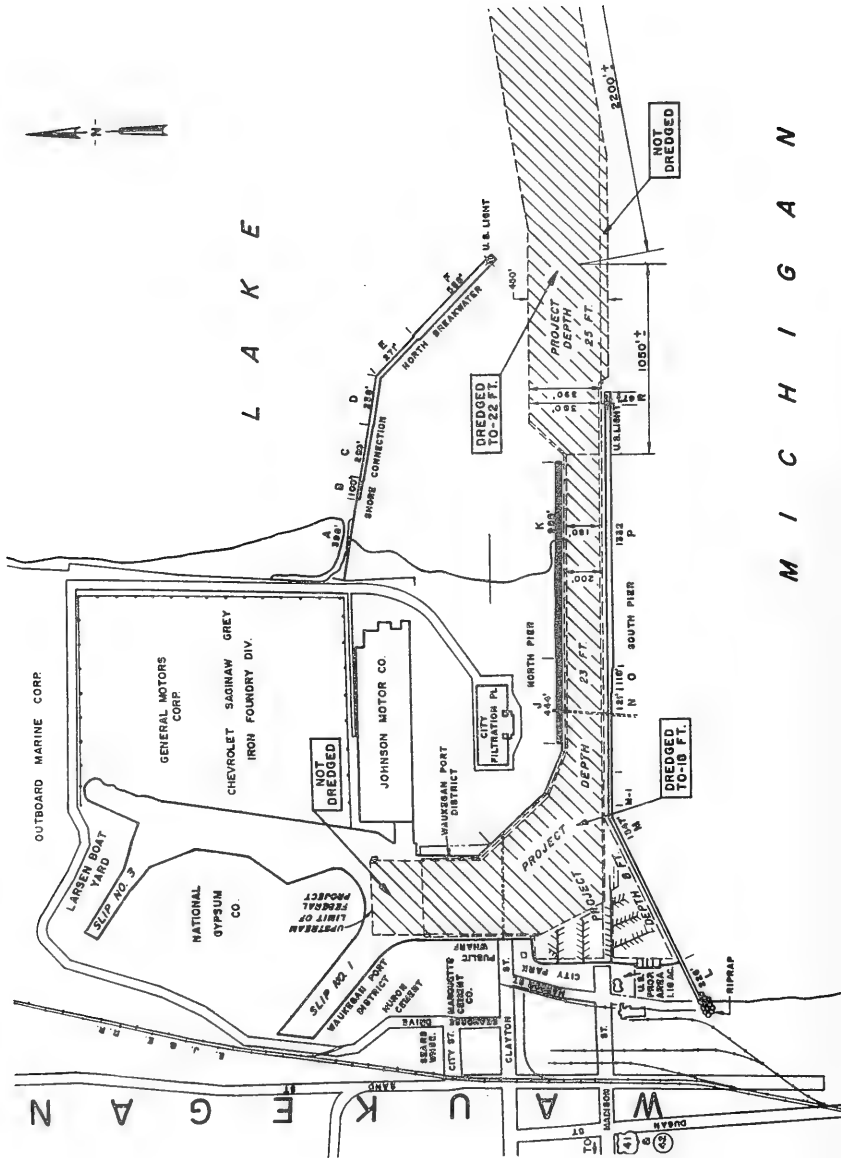
Waukegan Harbor StructuresWaukegan, Illinois

Date(s)	Construction and Rehabilitation History
1903	Construction of the 3,211-ft-long south pier (Figure 93, Sections L, M, N, O, P, and R) was completed. The shoreward 1,812 ft of the pier consisted of a wood-pile breakwater filled with stone (Figure 94, Sections L, M, N, and O). The structure was 14 ft in width. The outer 1,399 ft of the pier was a stone-filled timber crib structure (Figure 94, Sections P and R) with a width of 24 ft. With the exception of the shoreward 226 ft (Section L), riprap toe protection was placed along the toe of the pier.
1904	The lakeward 998 ft of the north pier (Figure 93, Section K) and 588 ft of the north breakwater (Figure 93, Section F) were constructed. The pier and breakwater consisted of stone-filled timber crib structures (Figure 95, Sections F and K). The widths of the pier and breakwater were 24 and 30 ft, respectively. Riprap toe protection was placed on both sides of the structures.
1906	The shoreward portion of the north pier (Figure 93, Section J) was constructed. The structure consisted of parallel timber walls with rock fill and a timber superstructure. The structure was 15 ft in width.
1930	The shoreward 1,573 ft of the south pier (Figure 93, Sections L and M) was capped with a stone and concrete superstructure. The crest el of the pier was +7.85 ft lwd, and it had a width of about 17 ft (Figure 94, Sections L and M).
1931	The existing north breakwater (Figure 93, Section F) was capped with a concrete superstructure and extended 271 ft shoreward (Figure 93, Section E). A 1,033-ft-long shore connection (Sections A, B, C, and D) was also constructed. The shoreward extension of the breakwater included a stone-filled concrete structure built on a stone base (Figure 95, Section E). The el of this extension and the new breakwater superstructure (Figure 95, Section F) was +7.1 ft lwd. The shoreward 398 ft of the shore connection consisted of steel sheetpiling with riprap on each side (Figure 95, Section A). The remaining portion of the shore connection consisted of parallel steel sheet piles ranging from 12 to about 17 ft in width (Figure 95, Sections B, C, and D). The area between the sheet piles was stone-filled and capped with concrete. The shore connection portion of the structure (Sections A, B, C, and D) had a crest el of +6.1 ft lwd.
1932	Concrete superstructures were built on the lakeward ends of the north (Figure 93, Section K) and south (Figure 93, Sections N, O, P, and R) piers. The north pier had a parapet wall installed to an el of

(Continued)

Table 36 (Concluded)

Date(s)	Construction and Rehabilitation History
	+7.1 ft lwd on the channel side (Figure 95, Section K). The south pier superstructure had crest els ranging from +7.6 to 8.85 ft lwd (Figure 94, Sections N, O, P, and R).
1960	A portion of the south pier (Figure 93, Section M-1) was repaired. Steel sheet piles were driven on each side of the existing structure. The voids were filled with stone, and the pier was capped with concrete at an el of +7.85 ft lwd (Figure 94, Section M-1). Stone toe protection was placed on each side of the structure.
1961	The shoreward portion of the north pier (Figure 93, Section J) was removed and rebuilt. Steel sheetpiling was installed at an el of +7.1 ft lwd and backfilled with earth fill (Figure 95, Section J). Riprap toe protection was also installed on the channel side of the pier.
1977	Portions of the south pier (Figure 93, Sections M and O) were rebuilt.
1978	An underwater intersection was made along the north pier which indicated that the structure was intact with the exception of construction joints. There were holes and gaps about 5 in. across at each construction joint along the wall. It was also noted that wood had rotted underneath the concrete cap at several locations. Maintenance repairs were made subsequent to the inspection.
1981	A superstructure condition survey indicated that the structures were in good condition.
1986	The structures have undergone rehabilitation and maintenance during their lifetime; however, they are presently considered to be in good condition. An aerial photograph of the harbor structures is shown in Figure 96.



M I C H I G A N

Figure 93. Waukegan Harbor, Illinois

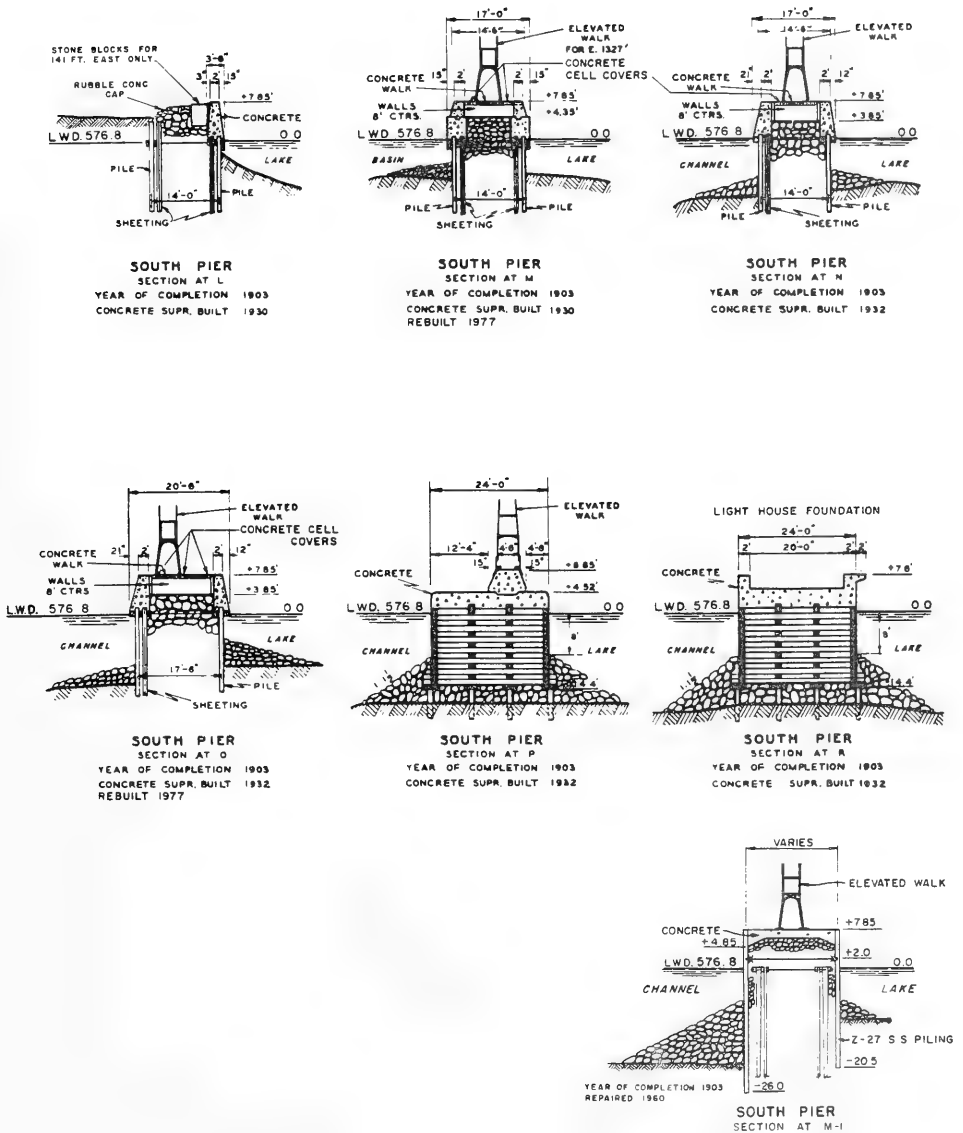
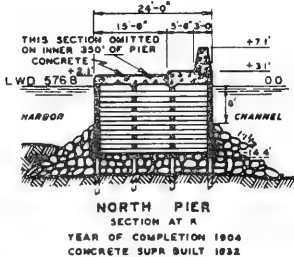
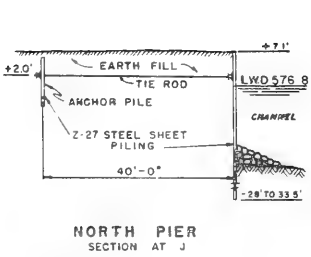
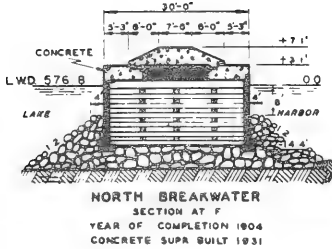
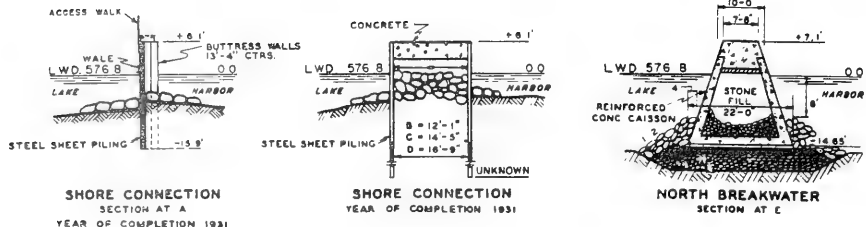


Figure 94. Typical pier cross sections, Waukegan Harbor, Illinois



ORIGINAL STRUCTURE REMOVED.  
REBUILT 1961

Figure 95. Typical structure cross sections, Waukegan Harbor, Illinois



Figure 96. Aerial view of Waukegan Harbor, Illinois

Table 37

Chicago Harbor StructuresChicago, Illinois

Date(s)	Construction and Rehabilitation History
1874	Construction of the 4,338-ft-long northern portion of the inner breakwater (Figure 97, Sections K, L, M, N, O, and U) was completed. The breakwater was constructed of stone-filled timber cribs on a stone base. It was 30 ft in width (Figure 98, Sections K through O and U).
1876	Construction of the 960-ft-long north pier (Figure 97) was completed. The pier was of stone-filled timber crib construction (Figure 98, Section J). It was built on a stone base and was 30 ft in width.
1880	The 2,544-ft-long southern portion of the inner breakwater (Figure 97, Sections P, R, and S) was constructed. These structures also were stone-filled timber cribs built on a stone base (Figure 98, Sections P, R, and S). The southern 2,244 ft of breakwater was 16 ft in length (Sections R and S), and the remaining 300-ft portion (Section P) was 30 ft in width.
1889	Construction of a 5,321-ft-long extension breakwater (Figure 97, Sections C, D, and E) was completed. This was a stone-filled timber crib breakwater (Figure 99, Sections C, D, and E) built on a stone base with a 30-ft width.
1908	The north pier was capped with a concrete superstructure (Figure 98, Section J) with a crest el of about +11 ft lwd.
1917	A 2,250-ft-long shore arm extension (Figure 97, Sections A, B1, B2, and B3) and a 2,227-ft-long southerly extension (Figure 97, Section F) of the exterior breakwater were constructed. The shore arm extension was constructed with stone-filled timber cribs (Figure 99, Sections A, B1, B2, and B3) built on a stone base. The shoreward 750-ft-length (Section A) was 24 ft in length, and the remaining breakwater (Sections B1, B2, and B3) was 30 ft wide. The southerly extension was a rubble-mound breakwater with 1V:1.5H side slopes (Figure 99, Section F). Its crest el was +8.44 ft lwd, and armor stone sizes were 3 tons (minimum) from el +1.72 ft lwd to the lake bottom and 7 tons (minimum) from el +1.72 to +8.44 ft lwd.
1920	An additional 1,532-ft-long portion of the southerly extension (Figure 97, Section G) was constructed. The extension was a rubble-mound structure with a crest el of +6.1 ft lwd and 1-V:1.5-H side slopes (Figure 99, Section G). Armor stone sizes ranged from 3 tons (minimum) from el 0.0 ft lwd to the lake bottom to 7 tons (minimum) from el 0.0 ft lwd to +6.1 ft lwd.

(Continued)

(Sheet 1 of 3)



Table 37 (Continued)

Date(s)	Construction and Rehabilitation History
1923	Construction of the southern end of the southerly extension (Figure 97, Section H) was completed. It consisted of a stone-filled concrete breakwater (Figure 99, Section H) built on a stone base. The crest el of the extension was +6.1 ft lwd, and its width was 8.3 ft.
1928- 1929	The exterior breakwater (Figure 97, Sections C, D, and E) was capped with a concrete superstructure. The crest el of the breakwater was +7.1 ft lwd. Riprap (7-ton average) was placed on the lakeside of the structure (Figure 99, Sections C, D, and E) to an el of +4.6 ft lwd on a 1-V:1.5-H slope. Seven-ton riprap also was placed on the harbor side in some areas (Figure 97, Sections C-4 and E).
1930	Portions of the inner breakwater (Figure 97, Sections O, P, R, and S) were capped with a concrete superstructure. The 150-ft-long portion of section O (Figure 98) included a parapet with an el of +8.85 ft lwd, and the 300-ft-long portion of P had a crest el of +7.1 ft lwd. The remaining portions (Sections R and S) were constructed with crest els of +6.43 ft lwd.
1934	The remaining sections of the inner breakwater (Figure 97, Sections K, L, M, N, and U) were capped with concrete superstructures. The longest length (3,488 ft) of structure (Section N) included a parapet with an el of +8.85 ft lwd (Figure 98). A 100-ft section of the breakwater (Section U) also included a parapet, but the crest el was +8.58 ft lwd. This portion of the breakwater also included the installation of steel sheetpiling on each side of the timber cribs and riprap toe protection (Figure 98, Section U). The northernmost end of the inner breakwater had a crest el of +5.1 ft lwd (Figure 98, Section K), and the remaining portions of the structure (Sections L and M) involved a +7.1-ft-lwd crest el.
1950	The inner end of the shore arm extension (Figure 97, Section A) was capped with a concrete superstructure. The superstructure included a parapet with an el of +7.0 ft lwd (Figure 99, Section A).
1955	A 1,000-ft-long portion of the shore arm extension (Figure 97, Section B2) was capped with a capstone superstructure. The minimum size of the capstone was 4 tons (Figure 99, Section B2), and the crest el was +7.0 ft lwd. A portion of the inner breakwater was repaired (Figure 97, Section R). Riprap (7-ton average) was placed on each side of the existing breakwater (Figure 98, Section R). The stone extended above lwd and had side slopes of 1V:1.5H.
1958	Riprap (7-ton average) was installed on each side of the southern end of the inner breakwater (Figures 97 and 98, Section S). The stone protruded above lwd and had 1-V:1.5-H side slopes.
1960	A 300-ft-long portion of the shore arm extension (Figure 97, Section B1) was capped with a concrete superstructure which included a parapet installed at an el of +7.0 ft lwd (Figure 99, Section B1).

(Continued)

(Sheet 2 of 3)

Table 37 (Concluded)

Date(s)	Construction and Rehabilitation History
1965	The lakeward end of the shore arm extension (Figure 97, Section B3) was capped with a concrete superstructure. The breakwater included a parapet installed at an el of +7.0 ft lwd (Figure 97, Section B3). Rubble (7-ton average) was added on each side of a portion of the inner breakwater (Figures 97 and 98, Section P), and the north pier (Figures 97 and 98, Section J) was repaired. The north pier and portions of the inner breakwater (Figure 98, Sections J, M, and N) were modified by the Metropolitan Sanitary District of Greater Chicago. This modification included the creation of wider structures by constructing a wall, filling voids with clay, and installing stone (Figure 98).
1979	A site inspection of the structures indicated cracks in the parapet walls of the shore arm extension (Figure 97, Sections A, B1, and B3). In Section B2 of the shore arm extension fill stone had settled; and cap stone was either settled, broken, or missing in some areas. Spalling at construction joints and along the edges of the exterior breakwater (Figure 97, Sections C, D, and E) was observed. Along Section E the timber structure in some places had deteriorated, and fill stone was missing. Cover stone was missing and/or deteriorated along Sections F and G (Figure 97) of the exterior breakwater southerly extension. Spalling at construction joints and along the edges of the inner breakwater (Figure 97, Sections M, N, P, and S) was noted. Maintenance of the breakwaters was performed subsequent to this inspection.
1981	A condition survey of the structures indicated that the shore arm extension (Figure 97, Sections A, B1, B2, and B3) were in good condition. The exterior breakwater (Sections C, D, and E) was also in good condition except for an area in Section E where failure of the crib substructure resulted in the superstructure's caving in. The exterior breakwater southerly extension was in good condition at Section H; however, in many locations along Sections F and G concrete fill between the armor stone had been lost. Also, many of the stones were split in pieces and disintegrating. In many locations stone was low (either lost or subsided). The north pier was in good condition except for minor spalling and weathering of concrete. The inner breakwater (Sections K, L, M, N, U, O, P, R, and S) was in good condition except for Sections N, U, and O where the concrete base slab was severely spalled and eroded with reinforcing bars exposed at the edges in many locations.
1983	Rubble-mound areas of the southerly extension (Figure 97, Sections F and G) were rehabilitated, and maintenance of the other faults noted in the condition survey of 1981 was performed.
1986	The structures are presently considered to be in good condition.



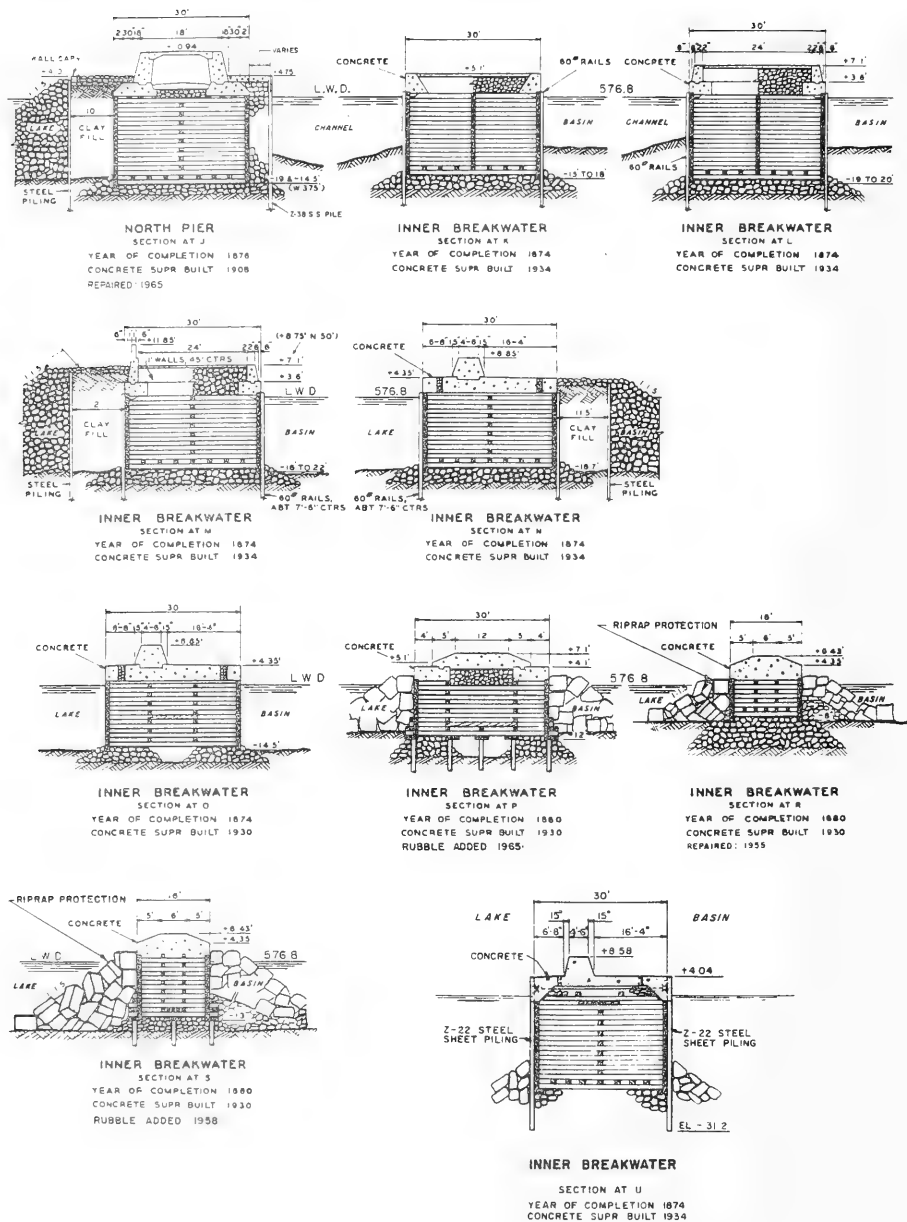


Figure 98. Typical structure cross sections, Chicago Harbor, Illinois

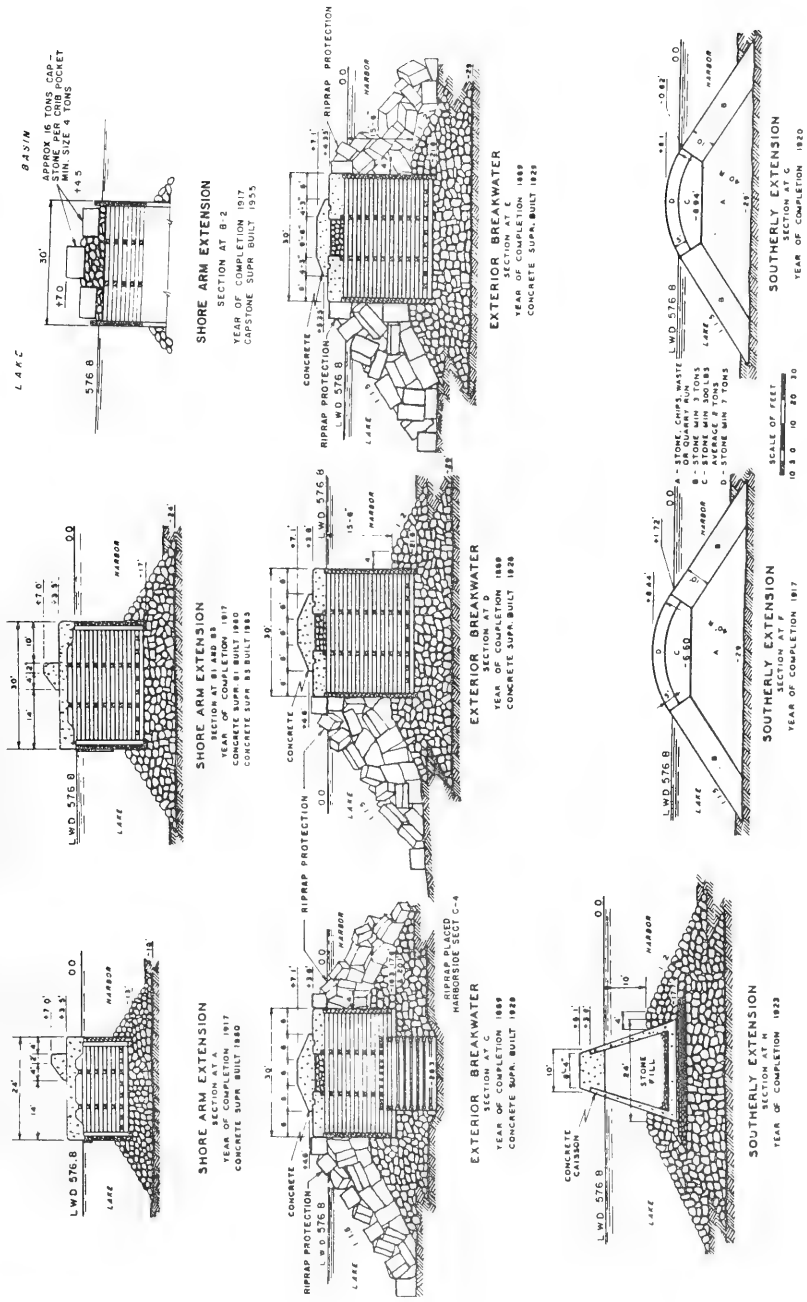


Figure 99. Typical breakwater cross sections, Chicago Harbor, Illinois

Table 38

Calumet Harbor BreakwatersCalumet Harbor and River, Illinois and Indiana

Date(s)	Construction and Rehabilitation History
1904	Construction of a 6,714-ft-long attached breakwater was completed (Figure 100, Sections A and B). The breakwaters were stone-filled timber crib structures built on a stone base. Riprap toe protection was installed on each side of the breakwater. The shoreward 1,700-ft length was 24 ft in width (Figure 101, Section A), and the remaining breakwater was 30 ft wide (Figure 101, Section B).
1921	The inner 1,700-ft portion of the breakwater (Figure 100, Section A) was capped with a stone and concrete superstructure, resulting in a crest el of +7.1 ft lwd (Figure 101, Section A).
1924	The outer 5,014-ft portion of the timber crib breakwater (Figure 100, Section B) was capped with a stone and concrete superstructure. The crest el of the breakwater was +7.1 ft lwd (Figure 101, Section B).
1935	Construction of a 5,007-ft-long cellular steel sheet-pile detached breakwater (Figure 100, Section C) was completed. The cells had a radius of 40 ft and were stone filled. Riprap toe protection was placed on each side of the breakwater. The structures were capped with stone (7 to 20 tons each) and had a crest el of +7.6 ft lwd (Figure 101, Section C).
1957	Portions of the detached breakwater (Figures 100 and 101, Sections C-1 and C-2) were repaired. Heavy riprap stone was placed on each side of the structure at the northern end (Section C-1) and on the lakeside of the breakwater on the southerly end (Section C-2).
1961- 1962	Portions of the attached timber crib breakwater (Figures 100 and 101, Sections A-1 and B-1) were repaired. Riprap protection was placed on the lakeside of the breakwater at Section A-1 and on the harbor side at Section B-1.
1984	A severe storm occurred in February with estimated wave heights of 15 ft. Two cells at the southern end of the detached breakwater failed, and the fill stone was lost under the impact of the storm waves. Stones ranging from 6 to 23 tons were placed on the ends of the damaged cells in October to stabilize them and prevent damage to adjacent cells. A total of 3,938 tons of stone was used during these repairs. During November a site inspection of the attached timber crib structure revealed damaged concrete with exposed rebar, spalling, concrete deterioration, fractured concrete, voids, and erosion of some cribs on the harbor side.
1985	A reconnaissance report for breakwater rehabilitation was published by NCC recommending conversion of the attached breakwater to a rubble-mound structure as an attempt to preserve the detached breakwater with rubble-mound berms installed on each side.

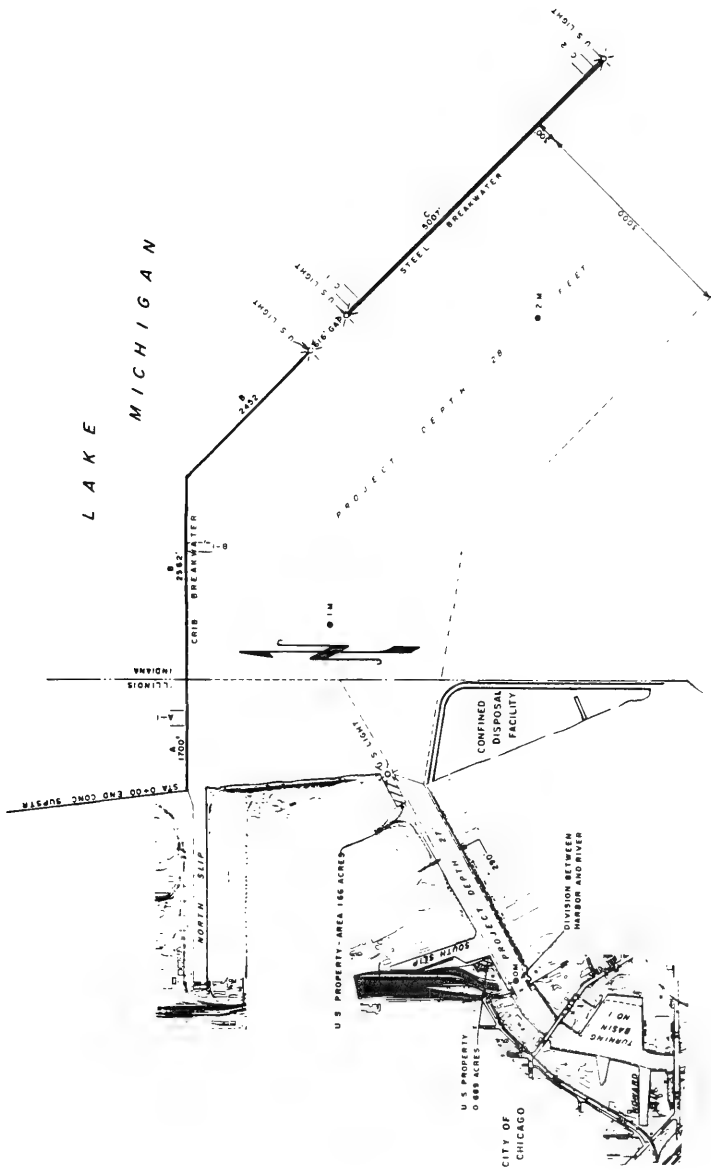


Figure 100. Calumet Harbor, Illinois and Indiana

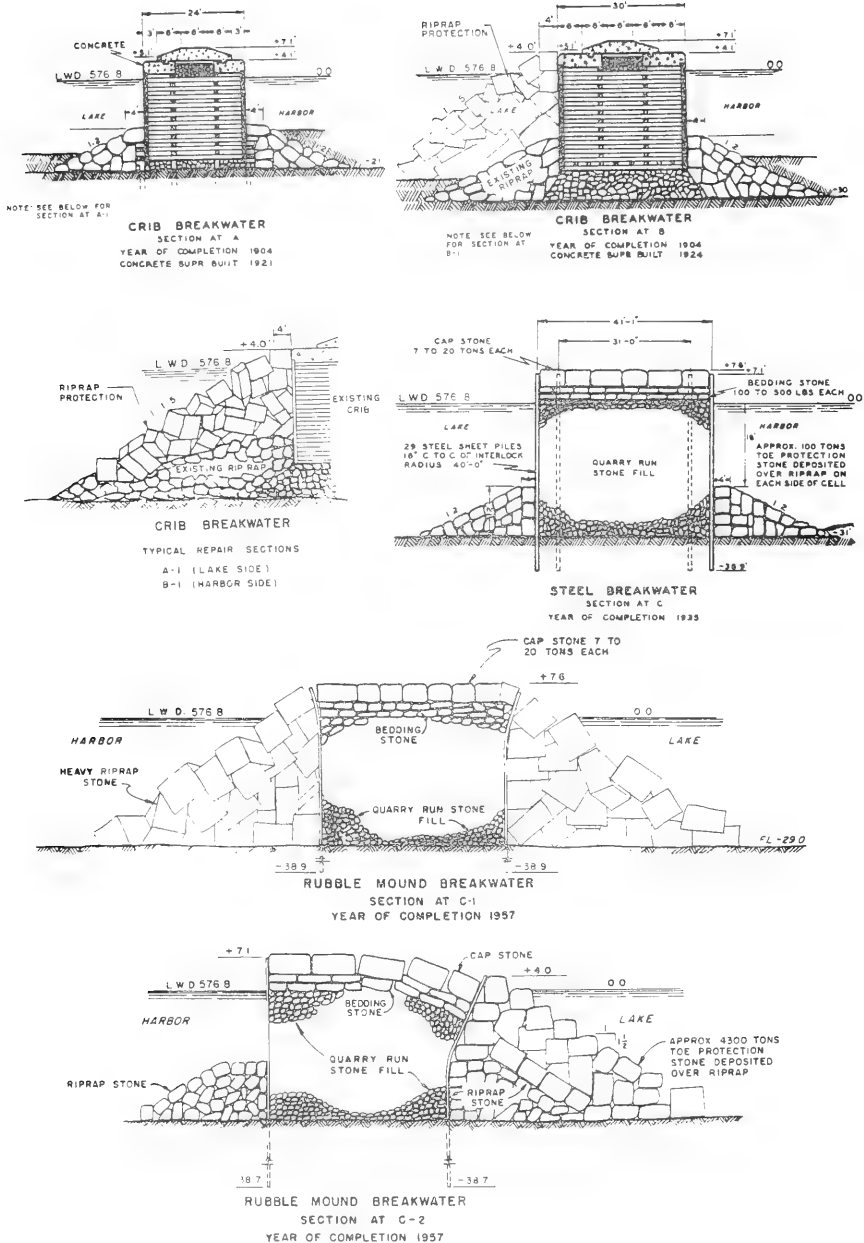


Figure 101. Typical structure cross sections, Calumet Harbor, Illinois and Indiana

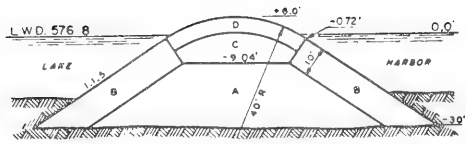


Table 39

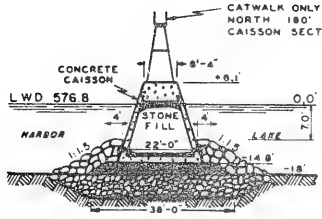
Indiana Harbor BreakwatersIndiana Harbor, Indiana

<u>Date(s)</u>	<u>Construction and Rehabilitation History</u>
1922	Construction of a 1,120-ft-long north breakwater (Figure 102, Section A) was completed. The breakwater was built of rubble-mound construction. It had a crest el of +6 ft lwd and side slopes of 1V:1.5H (Figure 103, Section A). Armor stone sizes along the crest were 7 tons (minimum), and armor stone along the slope (beneath the water surface) ranged from 1 to 7 tons with an average weight of 3 tons.
1926	Construction of a 201-ft-long east breakwater (Figure 102, Section B) was completed. The breakwater was a stone-filled concrete structure (Figure 103, Section B) built on a stone base. It had a crest el of +6.1 ft lwd and a width of 8.3 ft.
1935	A 2,324-ft-long lakeward rubble-mound extension of the each breakwater was completed (Figure 103, Section C). It had a crest el of +9.0 ft lwd, a crest width of 10 ft, and 1-V:1.5-H slide slopes. Armor stones along the crest ranged from 7 to 20 tons, and armor along the slope (beneath the water surface) ranged from 2 to 7 tons (Figure 103, Section C).
1951- 1957	A series of model tests was conducted (Hudson and Housley 1959) to determine the extent of reflected waves in the navigation channel and remedial measures required to alleviate the problems.
1986	Maintenance costs have been low throughout the lifetime of the breakwaters, and the structures are presently in good condition.

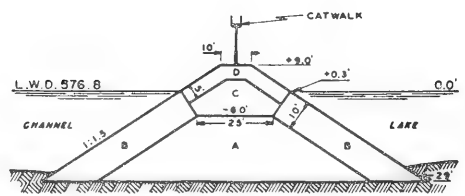




**NORTHERLY BREAKWATER**  
 SECTION AT A  
 YEAR OF COMPLETION 1922  
 A STONE-QUARRY RUN  
 B STONE-1 TO 7 TONS AV 3 TONS  
 C STONE-MIN 500<sup>lb</sup> MAX. 2000<sup>lb</sup>  
 D STONE-MIN 7 TONS



**EASTERLY BREAKWATER**  
 SECTION AT B  
 YEAR OF COMPLETION 1928  
 SCALE OF SEC B  
 10 5 0 10 20 30



**EASTERLY BREAKWATER**  
 SECTION AT C  
 YEAR OF COMPLETION 1933  
 A STONE-DUST TO 1 TON  
 B STONE- 2 TO 7 TONS  
 C STONE- 500<sup>lb</sup> TO 1 TON  
 D STONE- 7 TO 20 TONS

Figure 103. Typical breakwater cross sections, Indiana Harbor, Indiana

Table 40

Burns Harbor BreakwaterBurns Waterway, Indiana

Date(s)	Construction and Rehabilitation History
1968	Construction of a 5,830-ft-long, rubble-mound breakwater (Figure 104) was completed. The structure had a crest el of +14 ft lwd with a width of 17 ft. Armor stones ranging from 10 to 16 tons were placed with side slopes of 1V:1.5H. Model tests were conducted to determine breakwater stability (Jackson 1967).
1975	An inspection of the breakwater indicated that settlement of the structure in several locations below the constructed +14-ft-lwd crest el had occurred, and the breakwater was subsequently being overtopped during all seasons by less than the design waves. A total of 16,730 tons of stone was placed during the year. Stone sizes ranged from 3 to 16 tons having a 9-ton average.
1976	A total of 17,267 tons of stone ranging from 3 to 16 tons (9-ton average) was placed on the breakwater.
1977	A total of 10,027 tons of stone ranging from 3 to 16 tons (9-ton average) was placed on the breakwater.
1978	A total of 14,340 tons of stone ranging from 3 to 16 tons (9-ton average) was placed on the breakwater.
1980	A total of 47,334 tons of stone ranging from 3 to 16 tons (9-ton average) was placed on the breakwater.
1984	A storm in March caused damage to the breakwater dislodging armor stone in many areas and the overall integrity of the above-water stone placement.
1986	The breakwater has undergone extensive maintenance and rehabilitation since its construction because of structure slumping. The exact cause of the slumping is not known. A study is presently being conducted to identify the cause of the problem where remedial measures can be taken.

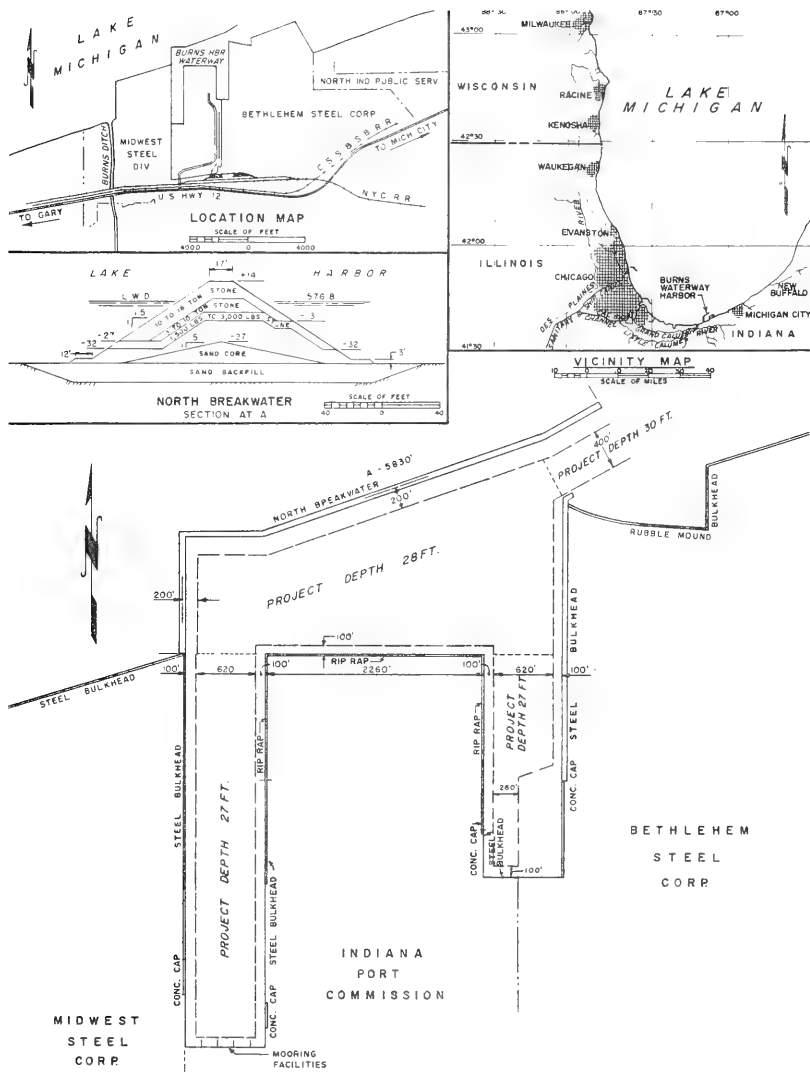


Figure 104. Burns Harbor, Indiana

Table 41  
Michigan City Harbor Structures  
Michigan City, Indiana

<u>Date(s)</u>	<u>Construction and Rehabilitation History</u>
1884	Construction of the 1,000-ft-long east breakwater (Figure 105, Section N) was completed. The breakwater was a timber crib structure with a width of about 29 ft (Figure 106, Section N).
1902	Construction of the 2,276-ft-long east pier (Figure 105, Sections G, H, J, K, L, M-1, and M) was completed. The pier was stone-filled timber crib structures (Figure 106) that ranged from about 18 to 34 ft in width.
1903	Construction of the 1,304-ft-long detached breakwater (Figure 105, Sections A, B, and C) was completed. This breakwater also was a timber crib structure (Figure 107, Sections A, B, and C) built on a stone base and was 30 ft in width.
1909	Construction of the 835-ft-long west pier (Figure 105, Sections D, E, and F) was completed. The pier consisted of a stone fill between woodpilings (Figure 107, Sections D, E, and F) that ranged in width from about 14 to 20 ft.
1911	The lakeward head of the detached breakwater (Figures 105 and 107, Section C) was capped with a concrete superstructure. The crest el of the breakwater was +10.5 ft lwd.
1923	The shoreward head of the detached breakwater (Figures 105 and 107, Section A) was capped with a concrete superstructure to an el of +6.1 ft lwd.
1925	The trunk section of the detached breakwater (Figures 105 and 107, Section B) was capped with a concrete superstructure to an el of +6.1 ft lwd.
1930	The shoreward portion of the east pier (Figures 105 and 106, Sections G, H, J, K, and L) was capped with concrete and/or stone superstructures. The crest el of the pier was installed at +7.85 ft lwd, and the crest widths ranged from 18 to 34.25 ft in width.
1931	The lakeward portions of the east (Figures 105 and 106, Sections M and M-1) and west (Figures 105 and 107, Sections E and F) piers were capped with stone and concrete superstructures. The crest el of the east pier was +10.1 ft lwd (Sections M and M-1). The crest of the lakeward portion of the west pier (Section F) was +10.52 ft lwd and the adjacent portion (Section E) was installed at an el of +7.85 ft lwd.

(Continued)

Table 41 (Concluded)

Date(s)	Construction and Rehabilitation History
1939- 1940	Riprap was placed on each side of the lakeward head of the detached breakwater (Figure 107, Section A). The crest of the riprap was placed at an el of +5.1 ft lwd, and side slopes of 1V:1.3H were installed. The east breakwater (Figures 105 and 106, Section N) was capped with a concrete superstructure to an el of +11.4 ft lwd.
1948	The shoreward end of the west pier (Figures 105 and 107, Section D) was reconstructed resulting in a pier that was 21 ft in width.
1968	Riprap was placed along both sides of the outer 1,106 ft of the detached breakwater (Figure 105, Sections B and C); both sides of the outer 537 ft of the west pier (Figure 105, Sections E and F); and along the outer 1,146 ft of the east pier (Figure 105, Sections M and M-1). Section M-1 included riprap on the lakeside only (Figure 106) with the crest at an el of +4 ft lwd. The outer end of the east pier (Figure 106, Section M) included riprap with a +4 ft lwd berm on the lakeside and a -2 ft el on the harbor side. Side slopes were 1V:1.5H. Riprap along the west pier (Figure 107, Sections E and F) was installed with side slopes of 1V:1.5H and an el of +4 ft lwd on the lakeside and below the surface of the water on the harbor side for toe protection. Riprap installed along both sides of the outer end of the detached breakwater (Figure 107, Sections B and C) was installed at an el of +4 ft lwd with side slopes of 1V:1.5H, with the exception of the head (Section C) which had a slope of 1V:2H on the lakeside.
1972	The shoreward portion of the west pier (Figure 105, Section D) and a portion of the east pier (Figure 105, Sections H and J) were rehabilitated. Steel sheetpiling was driven on each side of the existing piers, and the voids were filled with stone. The west pier (Figure 107, Section D) was capped with concrete with a crest el of +7 ft lwd and a new width of 28 ft. The east pier (Figure 106, Sections H and J) consisted of a concrete and stone cap installed at a cost el of +7.85 ft lwd. The inner portion (Section H) was 34 ft in width and remaining portion (Section J) was built 38 ft wide.
1978	The concrete cap on the shoreward end of the detached breakwater (Figures 105 and 107, Section A) was rebuilt.
1979	An inspection of the structures indicated that the east breakwater was in fair condition and the other structures generally were in good condition. Riprap on the lakeside of the detached breakwater was low in areas, and the concrete cap on the east pier had deteriorated in areas. Subsequent maintenance repairs have been performed.
1986	The structures are presently in good condition.

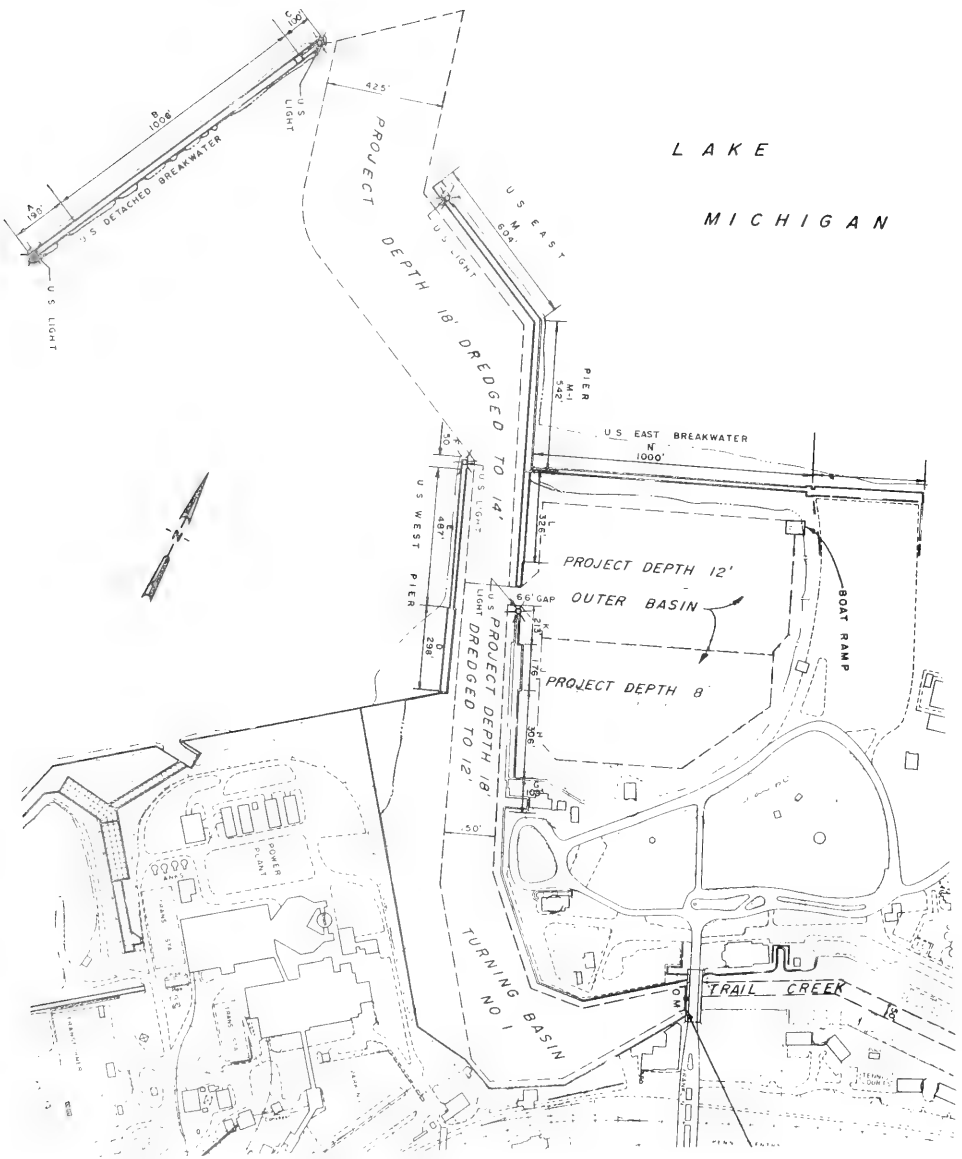


Figure 105. Michigan City Harbor, Indiana



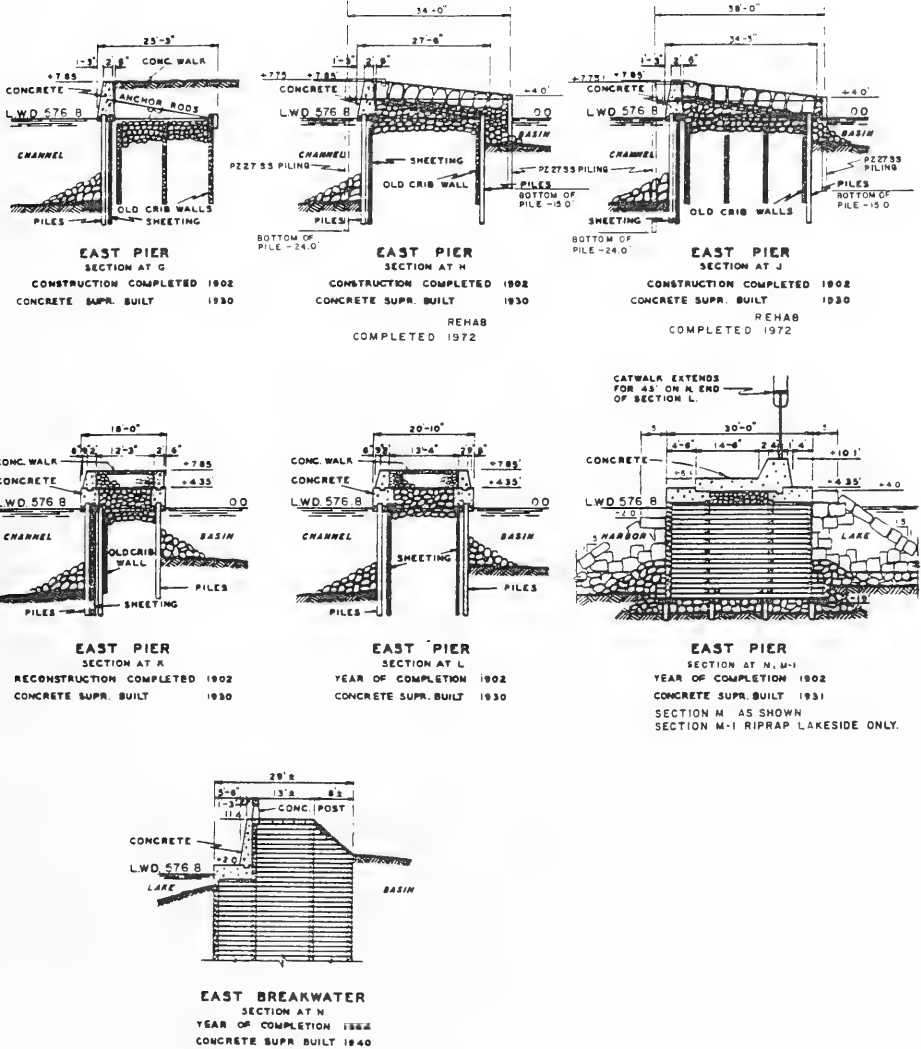
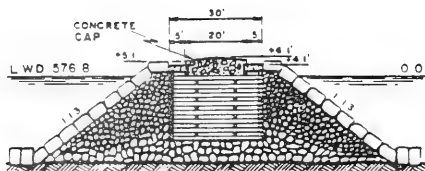
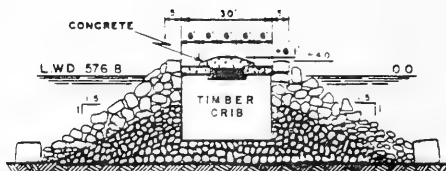


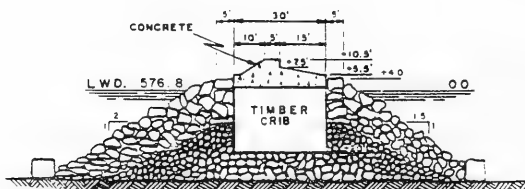
Figure 106. Typical east structure cross sections, Michigan City Harbor, Indiana



**DETACHED BREAKWATER**  
SECTION AT A  
YEAR OF COMPLETION 1903  
CONCRETE SUPR BUILT 1923  
RIPRAP PLACED 1939-40  
CONCRETE CAP REBUILT 1978



**DETACHED BREAKWATER**  
SECTION AT B  
YEAR OF COMPLETION 1903  
CONCRETE SUPR BUILT 1923  
RIPRAP PLACED 1968-69



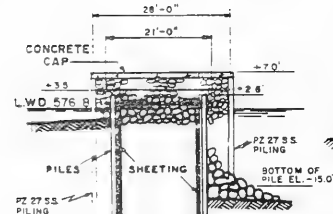
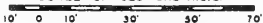
**DETACHED BREAKWATER**

SECTION AT C

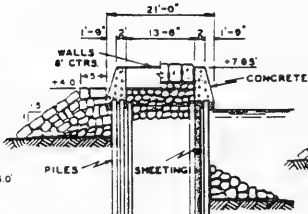
YEAR OF COMPLETION 1903  
CONCRETE SUPR BUILT 1911

RIPRAP PLACED 1968-69

SCALE OF SECTIONS A,B,C



**WEST PIER**  
SECTION AT D  
YEAR OF COMPLETION 1909  
RECONSTRUCTION COMPLETED 1948  
REHAB COMPLETED 1972



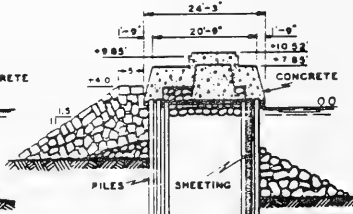
**WEST PIER**

SECTION AT E

YEAR OF COMPLETION 1909

CONCRETE SUPR BUILT 1931

RIPRAP PLACED 1968-69



**WEST PIER**

SECTION AT F

YEAR OF COMPLETION 1909

CONCRETE SUPR BUILT 1931

RIPRAP PLACED 1968-69

Figure 107. Typical structure cross sections, Michigan City Harbor, Indiana

Table 42

New Buffalo Harbor BreakwatersNew Buffalo, Michigan

Date(s)	Construction and Rehabilitation History
1975	<p>Construction of two breakwaters totaling 2,045 ft in length (Figure 108) was completed at the mouth of the Galien River. The outer 480 ft of the north breakwater (Figures 108 and 109, Reach-A) consisted of a rubble-mound structure with a crest el of +9.0 ft lwd and a width of 12 ft. Armor stone ranged from 10 to 16 tons (12-ton average). The adjacent shoreward portion of the north breakwater and the outer end of the south breakwater (Figures 108 and 109, Reach B) consisted of a rubble-mound structure with a crest width of 10 ft and an el of +8.0 ft lwd. Armor stone on this portion of the breakwater ranged from 5 to 10 tons (6-ton average). The adjacent shoreward portions of both structures (Figures 108 and 109, Reach C) involved a rubble-mound breakwater with a crest el of +8.0 ft lwd and a crest width of 8 ft. Armor stone ranged from 3 to 5 tons (4-ton average). The adjacent shoreward portions of the breakwaters (Figures 108 and 109, Reach D) included a rubble-mound structure with a crest el of +7.0 ft and a crest width of 6 ft. Armor stone ranged from 2 to 4 tons (3-ton average). All rubble-mound portions of the breakwaters had side slopes of 1V:1.5H. The inner ends of both breakwaters (Figure 108, Reach E) consisted of vertical steel sheetpiling with an el of +7 ft lwd. Riprap was placed on each side of the sheetpiling for toe protection. The breakwater configuration was model tested prior to construction (Dai and Wilson 1967).</p>
1980	<p>An inspection of the structures at the site indicated that voids existed in the outer reach (Reach A) of the north breakwater and minor settlement had occurred, particularly around the head of the structure adjacent to the navigation lights. The remaining portion of the rubble-mound north breakwater also consisted of many voids with some stones deteriorating (cracking or crumbling into smaller pieces). The outer portion of the south breakwater (Reaches B and C), although in better condition than the north structure, also had experienced some settlement and contained some gaps where waves washing through the structure was noted. The inner portion of the breakwaters was in good condition.</p>
1983	<p>Stone was placed in the voids of the outer portions of each breakwater (Reaches A and B, north breakwater, and Reach B, south breakwater, Figure 108). A site inspection in the latter part of the year revealed that some of the smaller stone (used to fit the voids) had washed out. Voids in the trunk sections of the breakwater (Reaches C and D, north structure, and Reach C, south structure) still existed along with settlement of 1 to 2 ft in some areas.</p>
1986	<p>The structures are presently considered in fair condition. Maintenance repairs of the breakwater have been recommended but not yet implemented.</p>

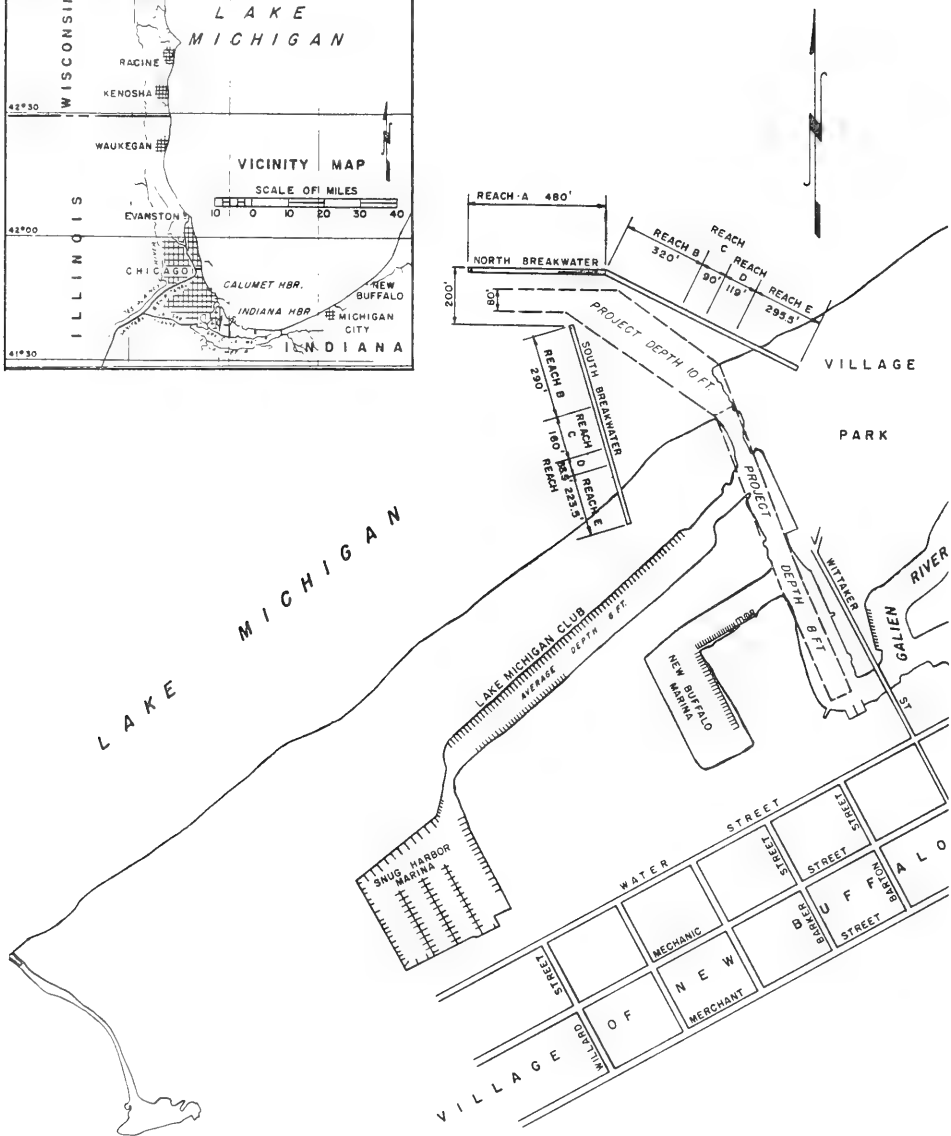
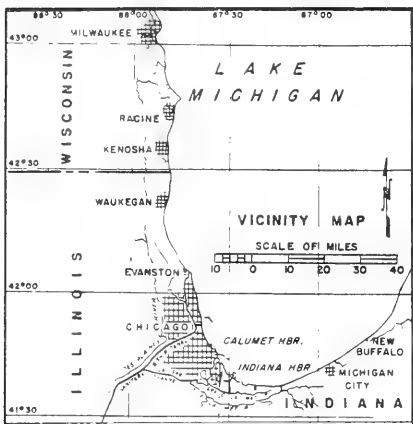
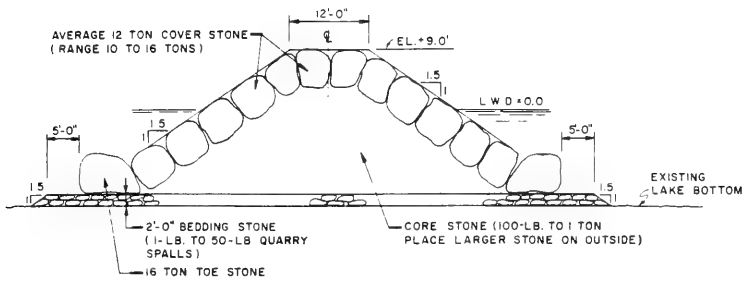
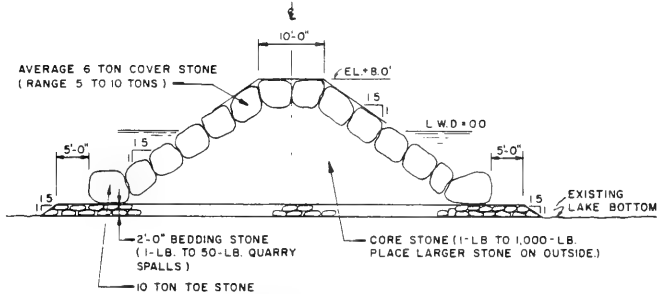


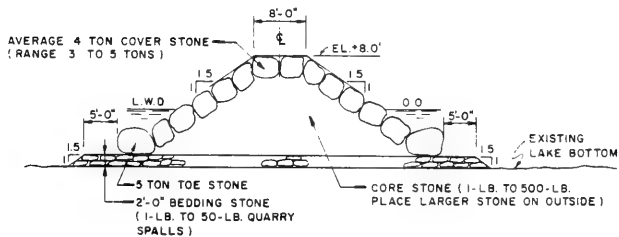
Figure 108. New Buffalo Harbor, Michigan



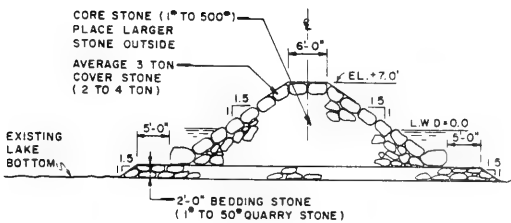
**REACH-A**  
BUILT 1975



**REACH-B**  
BUILT 1975



**REACH-C**  
BUILT 1975



**REACH-D**  
BUILT 1975

Figure 109. Typical breakwater cross sections,  
New Buffalo Harbor, Michigan

Table 43

Saint Joseph Harbor PiersSaint Joseph, Michigan

Date(s)	Construction and Rehabilitation History
1836- 1866	Construction of the inner 948 ft of the north pier (Figure 110, Sections C, D, and E) was completed during this time. (Figures 110, 111, 112, and 113 illustrate structures at St. Joseph Harbor.) The shoreward 573-ft portion was constructed of woodpilings spaced about 12 ft apart and filled with stone (Figure 112, Section E). The remaining portion of the work consisted of stone-filled timber crib structures that were 24 ft wide (Figure 112, Sections C and D).
1875- 1879	The north structure was extended lakeward by 354 ft (Figure 110, Section B) during this period. The pier extension consisted of a 24-ft wide, stone-filled, timber crib structure (Figure 112, Section B).
1880- 1881	The north structure again was extended lakeward (Figure 110, Sections A and A4). The length of the pier extension was 747 ft, and the structures were built of stone-filled timber cribs that were 30 ft in width (Figure 111, Sections A and A4).
1889- 1900	Construction of the inner 819 ft of the south pier (Figure 110, Sections I, J, K, and L) was completed during this time frame. The pier was constructed of woodpilings spaced from 26 to 34 ft apart and filled with earth and stone (Figure 113, Sections I, J, K, and L).
1901- 1903	Construction of the lakeward 709 ft of the north pier (Figure 110, Sections A1, A2, and A3) and the lakeward 1,784 ft of the south pier (Figure 110, Sections F, G, and H) was completed during this period. Both piers were constructed of stone-filled timber cribs built on a stone base. The entire north pier extension consisted of timber cribs that were 30 ft in width (Figure 111, Sections A1, A2, and A3). The south pier extension was 30 ft wide at its lakeward end (Figure 112, Section F) and 24 ft wide where it extended shoreward (Figure 112, Section G and Figure 113, Section H).
1911	The lakeward portion of the south pier (Figure 110, Section F) was capped with a concrete superstructure (Figure 112, Section F).
1918- 1919	The inner portion of the north pier (Figure 110, Section E) was capped with a concrete superstructure to an el of +7.0 ft lwd (Figure 112, Section E).
1924- 1925	A 426-ft-long portion of the south pier (Figure 110, Section H) was capped with a concrete and stone superstructure (Figure 113, Section H) to an el of +7.5 ft lwd.

(Continued)

(Sheet 1 of 3)

Table 43 (Continued)

Date(s)	Construction and Rehabilitation History
1927	Portions of the north (Figure 110, Sections C and D) and the south pier (Figure 110, Section I) were capped with concrete and stone superstructures. The crest el of the north pier was +7.0 ft lwd (Figure 112, Sections C and D) and the south pier had an el of +7.5 ft lwd (Figure 113, Section I).
1931	The lakeward end of the north pier (Figure 110, Sections A1, A2, A3, A4, A, and B) were capped with a concrete superstructure (Figure 111, Sections A1, A2, A3, A4, and A, and Figure 112, Section B).
1934	A 376-ft-long portion of the south pier (Figure 110, Section G) was capped with a concrete superstructure (Figure 112, Section G).
1941	The shoreward portion of the south pier (Figure 110, Sections J, K, and L) was capped with a concrete superstructure on the channel side (Figure 113, Sections J, K, and L). The crest el of the cap was 7.0 ft lwd, and it was backfilled with earth and stone.
1952- 1953	Portions of the north pier (Figure 110, Sections A1 and A2) were repaired by enclosing the structure in a steel sheetpiling encasement (Figure 111, Sections A1 and A2). Voids were filled with concrete, and the pier was recapped with concrete. The outer portion (Section A1) had a crest el of +8.0 ft lwd and was 35.5 ft wide, while the other portion (Section A2) was +7.1 ft lwd with a width of 35.5 ft. Riprap toe protection was also installed on each side of the piers adjacent to the new sheet-pile walls.
1961	Additional portions of the north pier were repaired (Figure 110, Section A4, C, D, and E) by using steel sheetpiling. The shoreward portions of the pier were repaired by installing sheetpiling on the channel sides of the existing structures (Figure 112, Sections C, D, and E) and backfilling the voids with stone prior to capping the area with concrete. The el of this portion of the pier was +7.0 ft lwd. The remaining portion of the pier was repaired by enclosing the structure in a steel sheet-pile encasement (Figure 111, Section A3). Voids were filled, and the structure was capped with concrete to an el of about +7.6 ft lwd. The pier width was approximately 36 ft.
1963	A portion of the north pier (Figure 110, Section A4) and a portion of the lakeward end of the south pier (Figure 110, Section F) were repaired by enclosing the structures in steel sheetpiling encasements (Figure 111, Section A4 and Figure 112, Section F). Voids between the sheetpiling were filled with stone, and the piers were capped with concrete. The structures were about 36 ft wide and had crest els of approximately 7.0 ft lwd after repairs were made. Riprap toe protection was also installed on each side of the piers.

(Continued)

(Sheet 2 of 3)

Table 43 (Concluded)

Date(s)	Construction and Rehabilitation History
1972	Additional portions of the south pier (Figure 110, Sections F, G, K, and L) were repaired. Section G and a portion of Section F were enclosed in a steel sheet-pile encasement (Figure 112). The voids between the sheetpiling were filled with stone, and the pier was capped with concrete to an el of about +7.0 ft lwd. After repairs the width of the structures was 36 ft (Section F) and 31 ft (Section G). Steel sheetpiling was installed on the channel side of the shoreward end of the south pier (Figure 113, Sections K and L). The voids were filled with stone, and a concrete cap installed.
1976	Another portion of the south pier underwent repairs (Figure 110, Sections I and J). Steel sheetpiling was installed on the channel side of the pier (Figure 113, Sections I and J), and the voids were filled with stone. The pier was capped with concrete to an el of +7.5 ft lwd.
1982	Stone fill in portions of the north pier (Figure 110, Sections A1, A, and B) was replenished, and new concrete caps were installed in these areas.
1985	An inspection of the structures revealed that fill stone was 3 to 6 ft low in areas of the north pier and that cracking of the superstructure was prevalent in places. It was also noted that fill stone in the south pier was settling which was also causing cracking of the concrete superstructure. Maintenance repair of the structures has been recommended but not yet performed. The piers are considered to be in fair condition.

(Sheet 3 of 3)



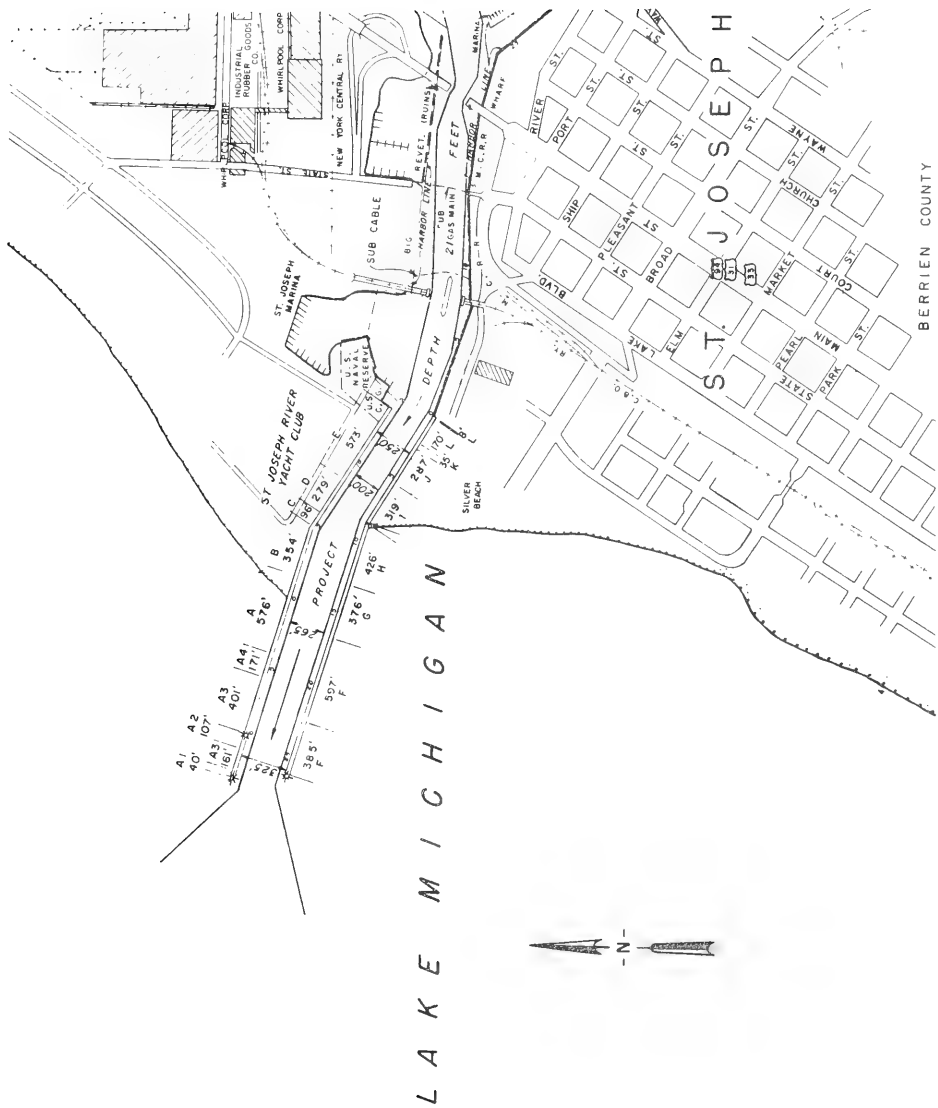
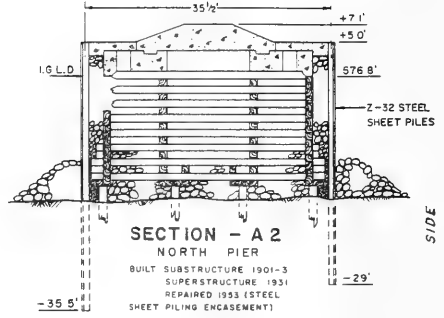
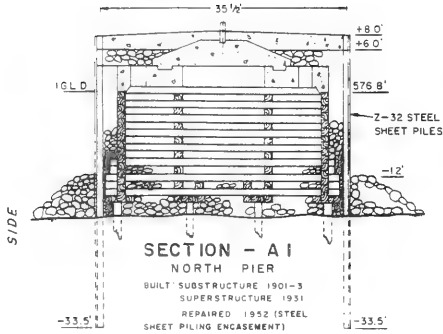


Figure 110. Saint Joseph Harbor, Michigan



CHANNEL

LAKE

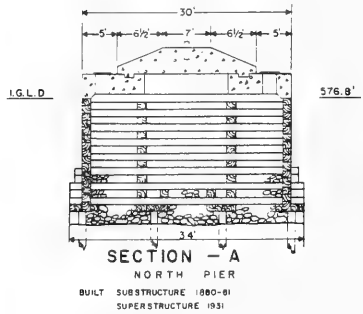
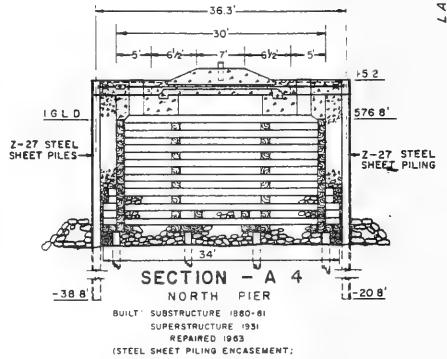
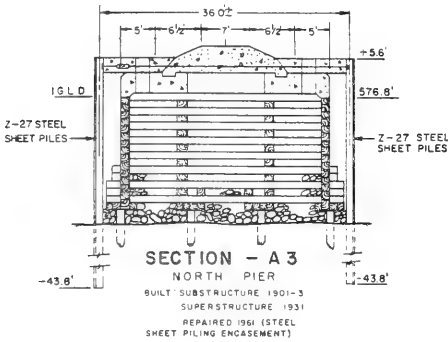


Figure 111. Typical north pier cross sections,  
Saint Joseph Harbor, Michigan

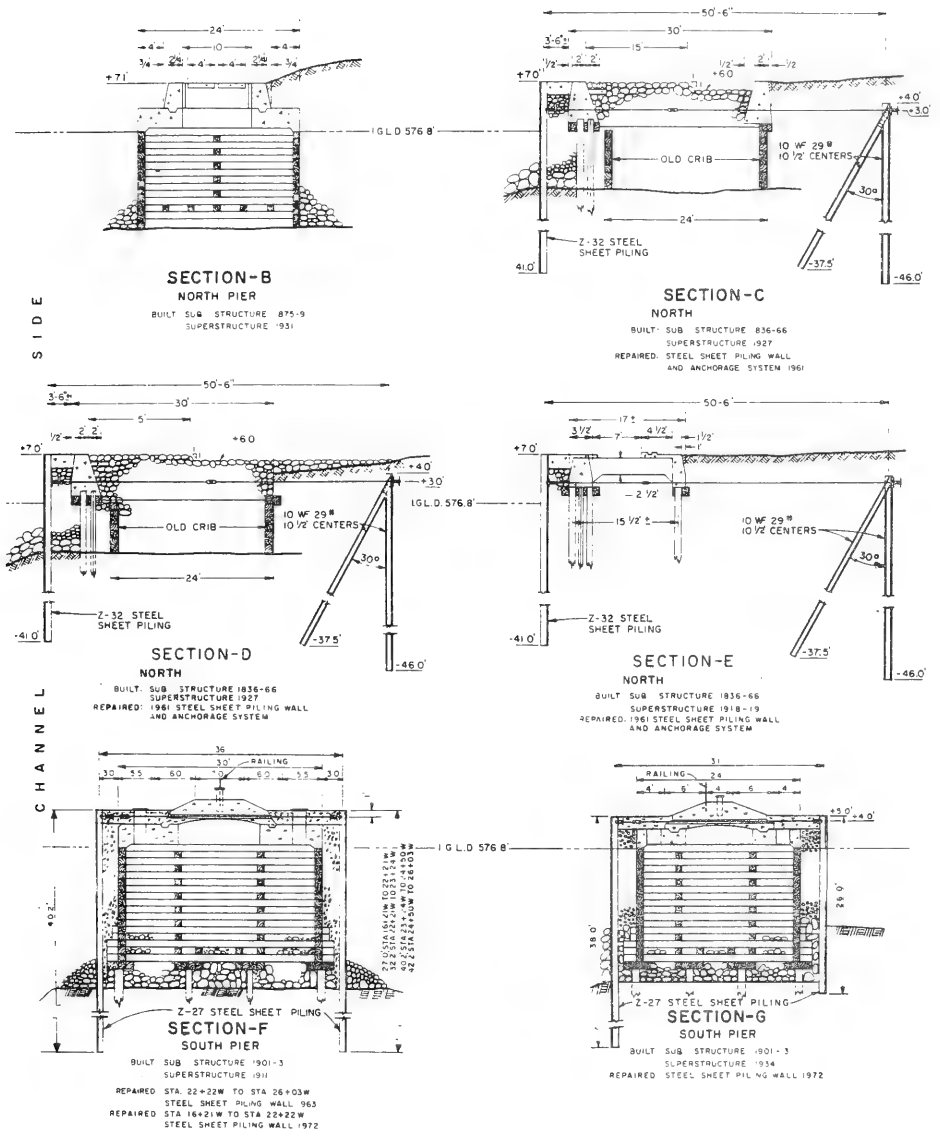


Figure 112. Typical pier cross sections, Saint Joseph Harbor, Michigan

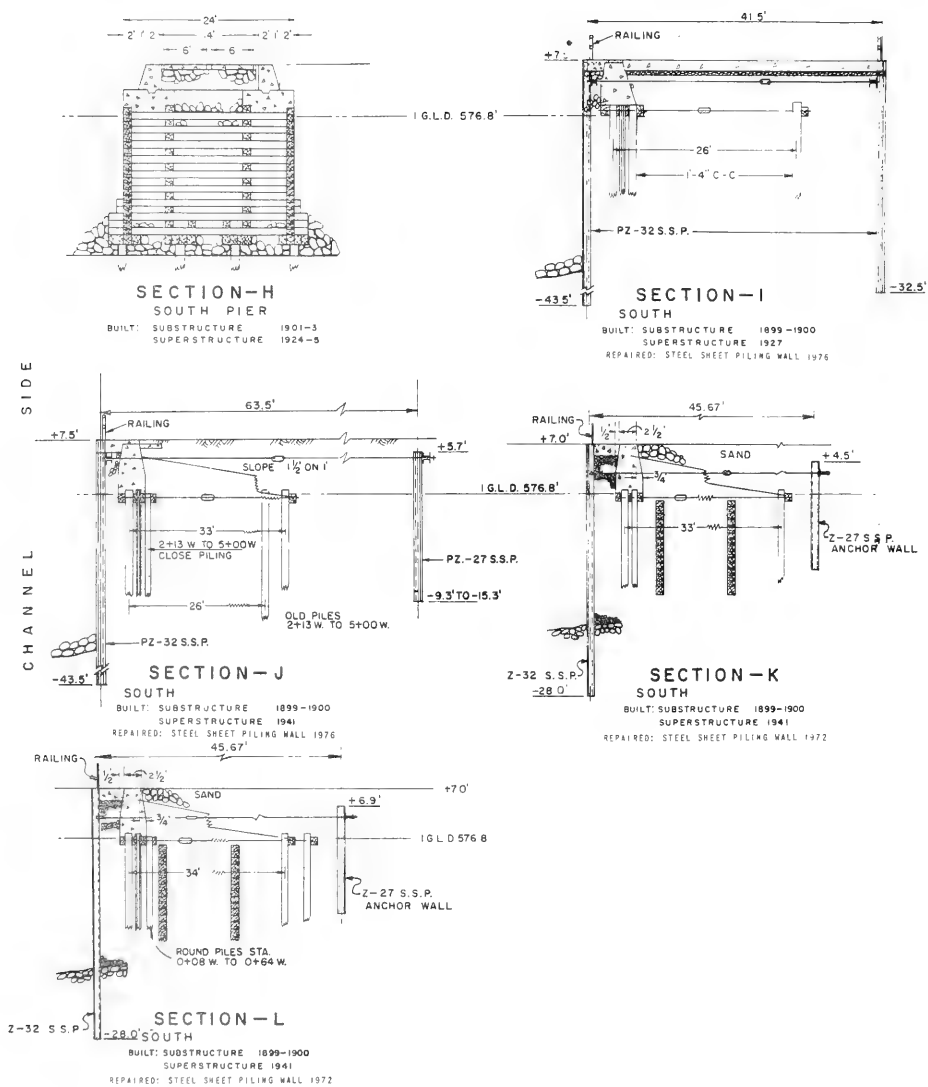


Figure 113. Typical structure cross sections, Saint Joseph Harbor, Michigan

Table 44

South Haven Harbor Piers  
South Haven, Michigan

<u>Date(s)</u>	<u>Construction and Rehabilitation History</u>
1868	Construction of the shoreward portion of the south pier (Figure 114, Section L) was completed. (Figures 114, 115, 116, and 117 illustrate structures at South Haven Harbor.) The pier was built with stone-filled timber crib structures and was about 20 ft in width (Figure 117, Section L).
1870- 1874	Construction of a 287-ft-long portion of the north pier (Figure 114, Section C) was completed. The structure consisted of a stone-filled timber crib that was 23 ft in width (Figure 115, Section C).
1871- 1874	Extension of the south pier by 150 ft (Figure 114, Sections K and K2) was completed during this period. The pier extension consisted of a 32-ft-wide, stone-filled timber crib structure (Figure 117, Sections K and K2).
1887	An additional 50-ft extension of the south pier (Figure 114, Section K1) was completed. The extension consisted of a stone-filled timber crib structure that was 30 ft in width (Figure 117, Section K1).
1888	Construction of the shoreward 320 ft of the north pier (Figure 114, Sections D and D1) was completed. These structures were 20-ft-wide stone-filled timber cribs (Figure 115, Sections D and D1).
1897- 1898	An additional 179-ft-long lakeward extension (Figure 114, Section J) of the south pier was constructed. The extension consisted of stone-filled wood-pilings spaced 25 ft apart (Figure 116, Section J).
1899	Another 200-ft lakeward extension of the north pier (Figure 114, Section H) was completed. The pier was built of a stone-filled timber crib structure which was 24 ft in width (Figure 116, Section H).
1900	A 200-ft lakeward extension of the north pier (Figure 114, Section B) was constructed. The pier was constructed of stone-filled timber cribs that were 24 ft in width (Figure 115, Section B).
1912- 1913	Construction of the lakeward portions of the north and south piers (Figure 114, Section A) was completed. Both these structures were 24-ft-wide, stone-filled timber cribs (Figures 115 and 116, Section A).
1924- 1925	The shoreward 784 ft of the south pier (Figure 114, Sections H, J, K1, K, K2, and L) was capped with a stone and concrete superstructure. The crest el of this structure ranged from +5.5 to +7.1 ft lwd (Figure 116, Sections J and H; and Figure 117, Sections K1, K, K2, and L).
1930- 1931	The shoreward 807 ft of the north pier (Figure 114, Sections B, C, D, and D1) was capped with a concrete superstructure. Crest els ranged from +6.5 to +7.0 ft lwd (Figure 115, Sections B, C, D, and D1).

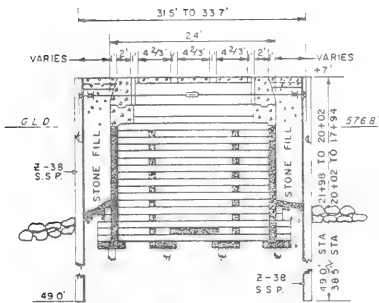
(Continued)

Table 44 (Concluded)

Date(s)	Construction and Rehabilitation History
1940	The landward portions of the north and south piers (Figure 114, Section A) were capped with stone and concrete superstructures resulting in pier crest els of +7.0 ft lwd (Figures 115 and 116, Section A).
1962- 1963	The entire north pier (Figure 114) was repaired during this time frame. Repairs consisted of installing steel sheetpiling on each side of the existing structures, filling the voids with stone, and capping the structure with concrete. Widths of the pier ranged from 31.5 to 40.5 ft (Figure 115, Sections A, B, C, D, and D1).
1964- 1965	A 179-ft portion of the south pier (Figure 114, Section J) was reconstructed. Steel sheetpiling was installed on each side of the existing pier forming a 32.7 ft-wide structure (Figure 116, Section J). The voids were filled with stone, and a concrete cap was installed.
1970- 1972	Additional portions of the south pier (Figure 114, Sections H, K1, K, K2, and L) were repaired during this period. These piers were repaired similar to the earlier ones by the installation of steel sheetpiling on each side of the existing pier. Voids were again stone filled and the structure capped (Figure 116, Section H; and Figure 117, Sections K1, K, K2, and L). Widths of the rehabilitated structure sections ranged from 30 to 42 ft.
1981	Riprap ranging from 1 to 6 tons was placed along the lakeside face of the north pier (Figure 114, Section A). Approximately 1,788 tons of stone was used that extended from the head of the pier 600 ft shoreward. Also, 38 tons of 2- to 4-in. stone was placed under the caps to replenish fill stone.
1982	Approximately 1,029 tons of riprap was placed along the north pier (Figure 114, Sections A and B) and 2,054 tons along the south pier (Figure 114, Section A). Three- to sixteen-ton stone was used for the purpose. Additionally, 40 tons of 1- to 3-ft stone was placed under the caps of the south pier to replenish fill stone.
1983	About 600 tons of 6- to 12-ton riprap was placed along the lakeside of the north pier shoreward of the riprap placement of 1981 and 1982.
1985	An inspection of the structures revealed that the north pier was in good condition. The lakeward end of the south pier (Figure 114, Section A) appeared stable and in fair condition. Separation, settlement, and cracking of the superstructure was noted, and maintenance repairs have been recommended. The remaining portions of the south pier were in good to excellent condition. An aerial view of the South Haven Harbor piers is shown in Figure 118.

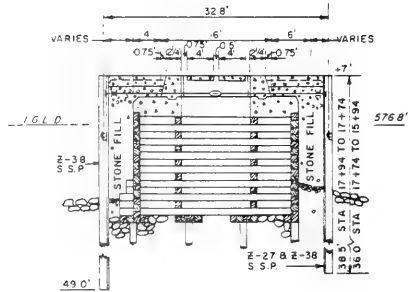


Figure 114. South Haven Harbor, Michigan



**SECTION-A**

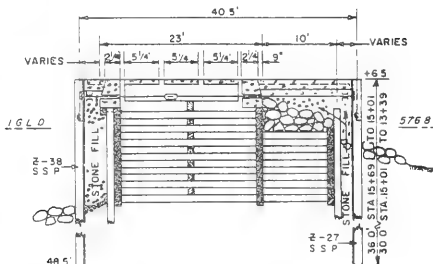
**NORTH PIER**  
 BUILT: SUBSTRUCTURE 192-13  
 SUPERSTRUCTURE 1940  
 REPAIRED 1962



**SECTION-B**

**NORTH PIER**  
 BUILT: SUBSTRUCTURE 1900  
 SUPERSTRUCTURE 1930  
 REPAIRED 1962

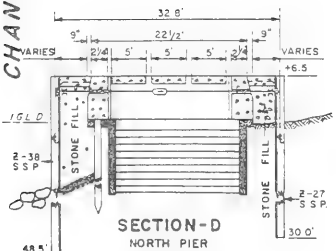
*SIDE*



**SECTION-C**

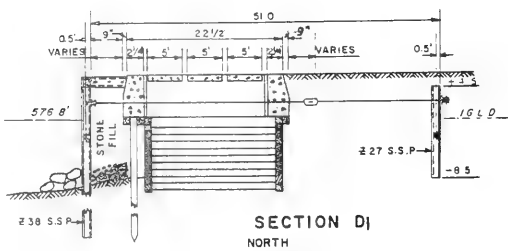
**NORTH PIER**  
 BUILT: SUBSTRUCTURE 1870-71, 73-74  
 SUPERSTRUCTURE 1930  
 REPAIRED 1962

*CHANNEL*



**SECTION-D**

**NORTH PIER**  
 BUILT: SUBSTRUCTURE 1888  
 SUPERSTRUCTURE 1931  
 REPAIRED 1963



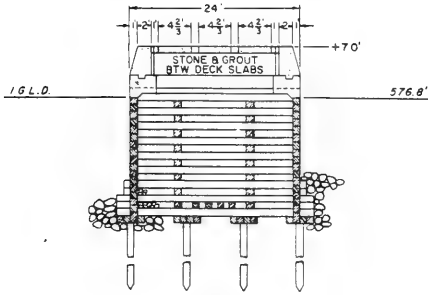
**SECTION D1**

**NORTH**  
 BUILT: SUBSTRUCTURE 1888  
 SUPERSTRUCTURE 1931  
 REPAIRED 1963

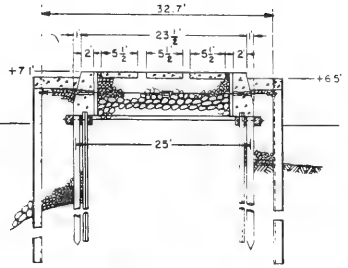
Figure 115. Typical north pier cross sections, South Haven Harbor, Michigan



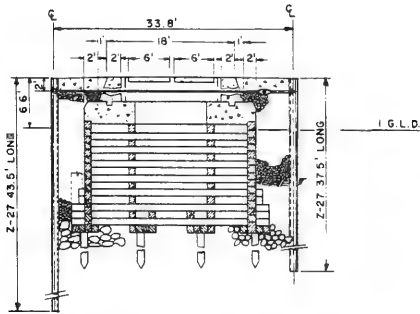
SIDE



**SECTION-A**  
SOUTH PIER  
BUILT: SUBSTRUCTURE 1912-13  
SUPERSTRUCTURE 1940



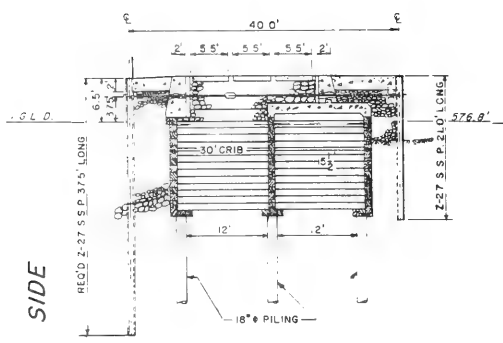
**SECTION-J**  
SOUTH PIER  
BUILT: SUBSTRUCTURE 1897-99  
SUPERSTRUCTURE 1924  
RECONSTRUCTED 1964-65



**SECTION-H**  
SOUTH PIER  
BUILT: SUBSTRUCTURE 1899  
SUPERSTRUCTURE 1924  
REPAIRED S.S.P. 1970-72

CHANNEL

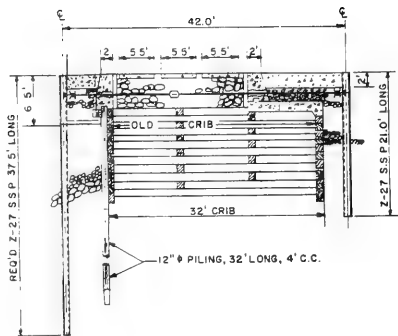
Figure 116. Typical south pier cross sections,  
South Haven Harbor, Michigan



SIDE

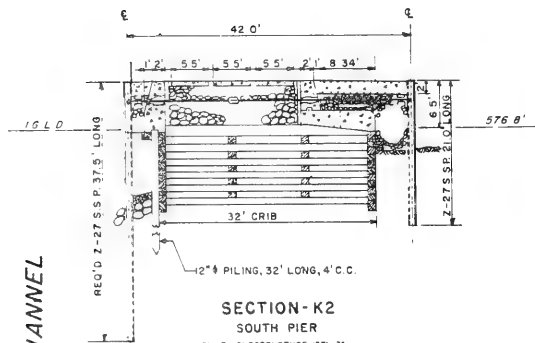
**SECTION-J**  
SOUTH PIER

BUILT: SUBSTRUCTURE 1887  
SUPERSTRUCTURE 1924  
REPAIRED S.S.P. 1970-72



**SECTION-K**  
SOUTH PIER

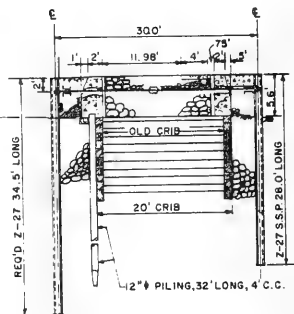
BUILT: SUBSTRUCTURE 1871-74  
SUPERSTRUCTURE 1924-25  
REPAIRED S.S.P. 1970- 2



CHANNEL

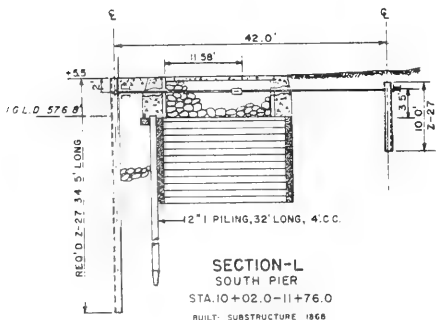
**SECTION-K2**  
SOUTH PIER

BUILT: SUBSTRUCTURE 1871-74  
SUPERSTRUCTURE 1924-25  
REPAIRED S.S.P. 1970-72



**SECTION-L**  
SOUTH PIER

STA. 11+77.5-18+53.0  
BUILT: SUBSTRUCTURE 1868  
SUPERSTRUCTURE 1925  
REPAIRED S.S.P. 1970-72



**SECTION-L**  
SOUTH PIER

STA. 10+02.0-11+76.0  
BUILT: SUBSTRUCTURE 1868  
SUPERSTRUCTURE 1925  
REPAIRED S.S.P. 1970-72

Figure 117. Typical pier cross sections, South Haven Harbor, Michigan



Figure 118. Aerial view of South Haven Harbor, Michigan

Table 45  
Saugatuck Harbor Piers  
Saugatuck, Michigan

Date(s)	Construction and Rehabilitation History
1904- 1905	Construction of the lakeward portions of the north and south piers (Figure 119, Sections A, B, and C) was completed during this time frame. The extreme outer portions were constructed of 24-ft-wide stone-filled timber cribs (Figure 120, Section A). Riprap toe protection was placed on each side of the timber cribs. The remaining portions of the pier (Sections B and C) were constructed of wood-piling spaced 13 ft apart (Figure 120, Sections B and C) and filled with stone.
1906- 1908	Construction of the shoreward portions of the north and south piers (Figure 119, Sections D, E, and F) was completed during this period. These piers ranged from 13 to 14 ft in width and were built with woodpilings (Figure 120, Sections D, E, and F).
1936- 1938	The north and south piers (Figure 119) were capped with concrete and/or stone superstructure. The lakeward portions of the piers were installed at a crest el of +7.0 ft lwd (Figure 120, Sections A, B, and C). The crest el of the shoreward portions of the piers was +6.0 ft lwd (Figure 120, Sections D, E, and F).
1959	A 375-ft portion of the south pier (Figure 119, Section F1) was rebuilt. Steel sheetpiling was utilized and backfilled with earth and a stone cap (Figure 120, Section F1). The el of this section of pier was +6.0 ft lwd.
1974	Fill stone replenishment for the north (Figure 114, Sections C and F) and south (Sections C, D, E, and F) piers was performed.
1980	An inspection of the piers revealed cracking, settlement, separation, misalignment, and tilting of the superstructures in various areas on both piers. Fill stone in most the piers was in need of replenishment also. The structures were in fair to poor condition with the exception of Section F1 (Figures 119 and 120) which was reconstructed in 1959.
1981	Approximately 500 tons of 1- to 8-ton riprap was placed along the west end and lakeside face of the south pier from the pier head to a point 100 ft shoreward. About 115 tons of 3- to 12-in stone fill also was placed under the superstructure at Section B (Figure 119) of the south pier. In addition, sand backfill was placed along 100 ft of Section D of the south pier and 500 ft of Sections E and F of the north pier.
1982	Approximately 300 tons of 6- to 12-in. fill stone was used to replenish the stone fill under the superstructure of the south pier. Additionally, about 500 tons of 50- to 300-lb ballast fill stone was placed into Section C (Figure 119) and along the lakeside of

(Continued)

Table 45 (Concluded)

Date(s)	Construction and Rehabilitation History
	Section D of the south pier. About 470 tons of the 50- to 300-lb ballast stone was placed into or along the north revetment.
1985	An inspection of the structures indicated the north pier to be in fair to poor condition. Fill stone had again settled, and the superstructure was still in poor condition because of cracking, settlement, tilting, etc. The south pierhead was in a poor to near failed condition (Figure 119, Section A), while the remaining portion of the pier is in a condition of fair to poor similar to the north pier. The only exception is Section F1 which is still considered to be in good condition.
1986	A major rehabilitation study for the piers is under way. Consideration is being given to using rubble-mound structures as opposed to vertical steel sheetpiling. An aerial photo of the Saugatuck Harbor Piers is shown in Figure 121.



Figure 119. Saugatuck Harbor, Michigan

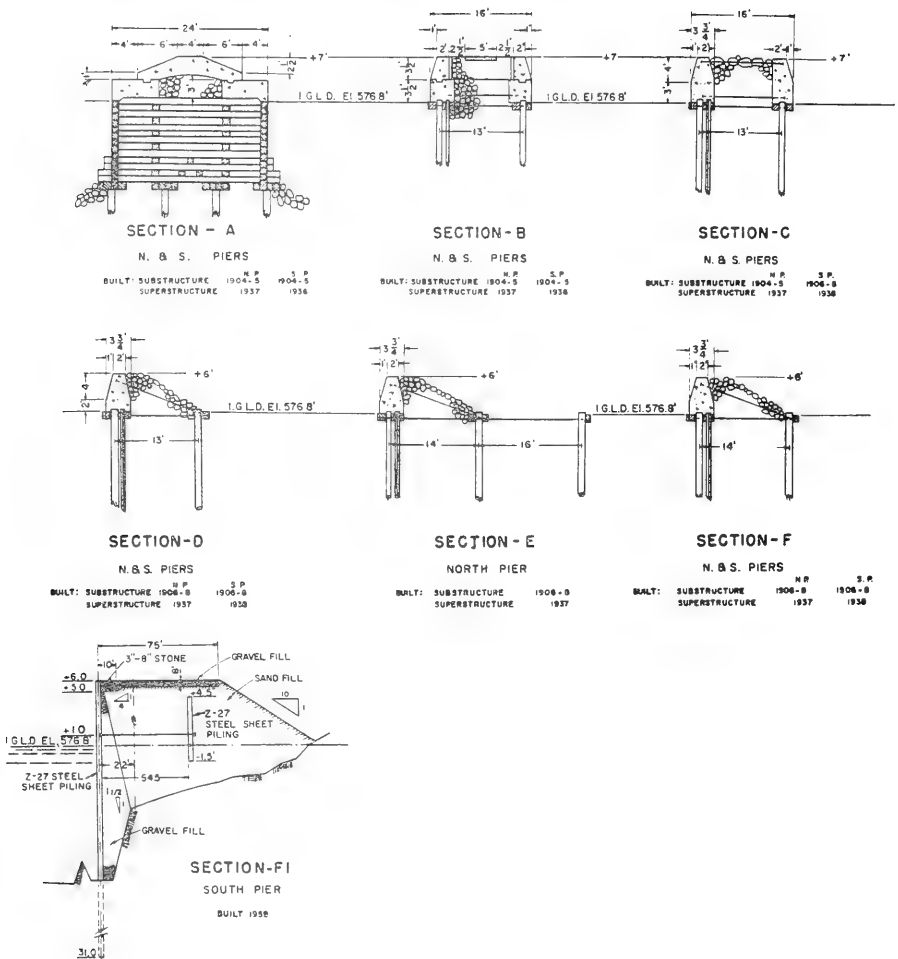


Figure 120. Typical pier cross sections, Saugatuck Harbor, Michigan

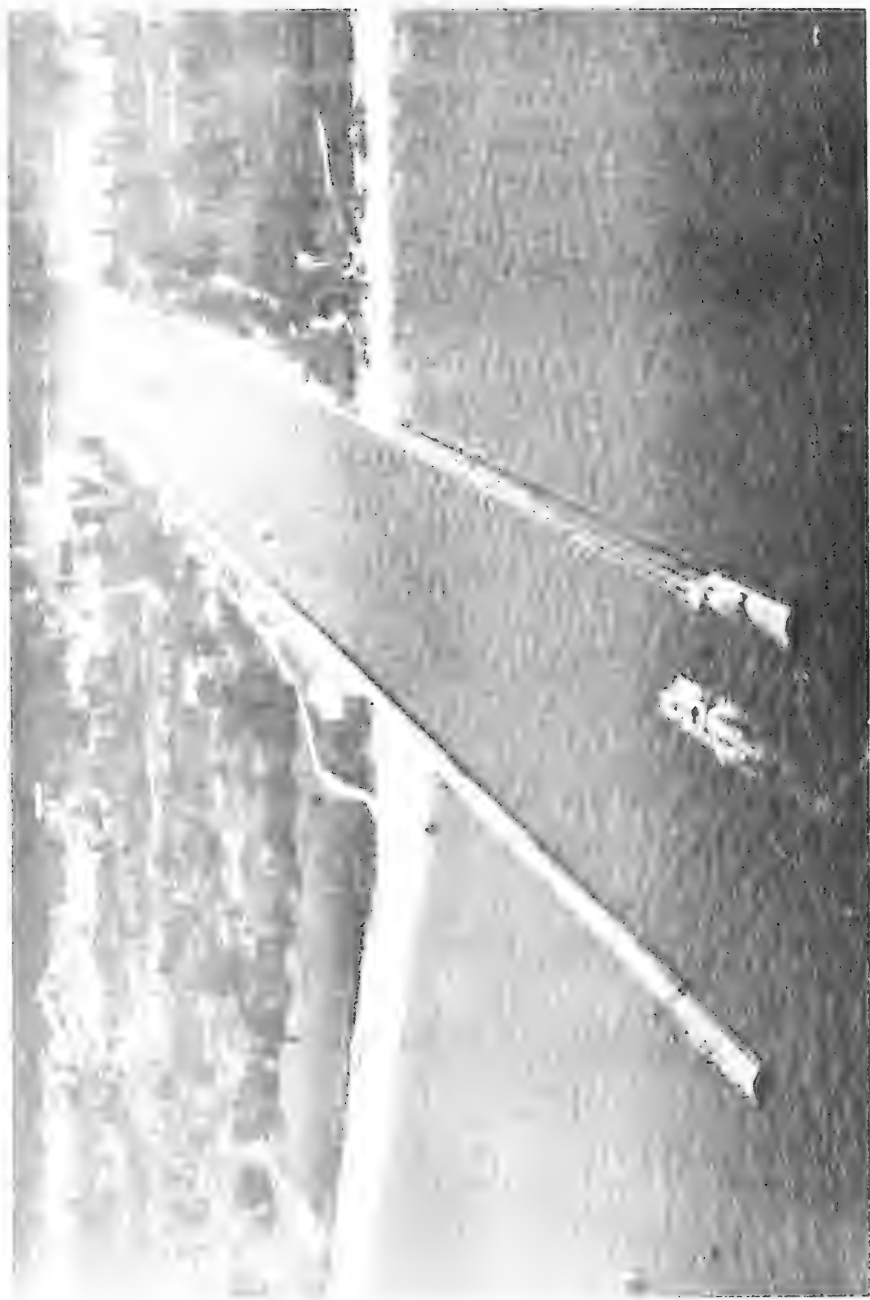


Figure 121. Aerial view of Saugatuck Harbor, Michigan

Table 46  
Holland Harbor Structures  
Holland, Michigan

Date(s)	Construction and Rehabilitation History
1868- 1879	Construction of the south pier (Figures 122, 123 and 124, Sections I and J) and a portion of the north pier (Figure 123, Section D) was completed at the site (Figure 122) during this period of time. The north pier (Section D) consisted of woodpilings driven about 24 ft apart and filled with earth and stone, while the south pier (Sections I and J) involved a 20-ft-wide, stone-filled timber crib structure.
1875- 1876	Construction of the lakeward end of the north pier (Figure 123, Section C) was completed during this period. The pier consisted of a 20-ft-wide stone-filled timber crib structure.
1906- 1909	Construction of the north and south arrowhead breakwater arms (Figure 123, Sections A1, A and B) was completed at the site (Figure 122). The lakeward portions (Sections A1 and A) were constructed with 30-ft-wide stone-filled timber cribs, while the shoreward portions of the breakwater (Section B) were built with 24-ft-wide stone-filled timber cribs.
1908- 1909	Construction of the breakwater pier connections (Figure 123, Section Q) was completed during this period. They consisted of woodpilings driven 12 ft apart and filled with stone. The el was +2.0 ft lwd. Rubble was placed on each side of the structure to the +2 ft lwd crest el and extended down on a slope of 1V:1.5H.
1929	The north pier (Figure 123, Sections C and D) was capped with a concrete and stone superstructure. The el of the lakeward end of the pier (Section C) was +7.1 ft lwd, and the shoreward end (Section D) was installed at a crest el of +6.1 ft lwd.
1932- 1933	The south pier (Figures 123 and 124, Sections I and J) and both breakwaters (Figure 123, Sections A1, A, and B) were capped with stone and concrete superstructures during this time. The south pier and both breakwaters were constructed to els of +7.1 ft lwd.
1958	The north pier (Figure 123, Sections C and D) was repaired. Steel sheetpiling was installed on each side of the structure, and the voids were filled with stone and capped with concrete. The width of the lakeward portion (Section C) was 32 ft, and that of the shoreward portion (Section D) was 33.8 ft.
1963- 1964	Rehabilitation of the lakeward heads of the breakwaters (Figure 123, Section A1), the pier connections (Figure 123, Section Q), and the south pier (Figures 123 and 124, Sections I and J) was completed.

(Continued)



Table 46 (Concluded)

Date(s)	Construction and Rehabilitation History
	Steel sheetpiling was driven on each side of the breakwater heads (Section A1) forming a structure 40.3 ft in width. The voids were stone filled and capped with concrete. The pier connections (Section Q) were capped with an 8-ft-wide precast concrete slab at an el of +4.5 ft lwd. Stone was added to the channel side and the lakeside of the structure with slopes of 1V:2H and 1V:1.5H, respectively. Steel sheetpiling also was added along the sides of the south pier (Figures I and J). The voids were filled with stone, and a concrete cap was added.
1979	An inspection of the structures indicated that the breakwaters and north pier were in good condition, while the south pier revealed cracks, settlement, and erosion of concrete and was considered in fair condition. It was noted that replenishment of riprap stone was required in some areas along the breakwater.
1980	Riprap stone was placed around the lakeward end of the north breakwater (Section A1) on the lakeside. The north and south pier connections underwent replenishment of stone in areas that had settled. The lakeward 55 ft of the south pier (Section I) and a 55-ft-long portion of Section J were rehabilitated. Precast concrete caps were installed.
1983- 1984	A 142-ft-long portion of the north breakwater (Figure 123, Section B) and a 124-ft-long portion of the south breakwater (Section A) were encased with steel sheetpiling, filled with stone, and capped with concrete. The remaining portions of Section B (north breakwater) and Section A (south breakwater) were encased with protection stone. Approximately 80,000 tons of stone was used, and the cost was approximately \$3,000,000.
1985	An inspection of the structures revealed them to be generally in good condition. Fill stone replenishment was recommended, however, at the lakeward heads of the breakwaters (Figure 123, Section A1). An aerial view of Holland Harbor Structures is shown in Figure 125.

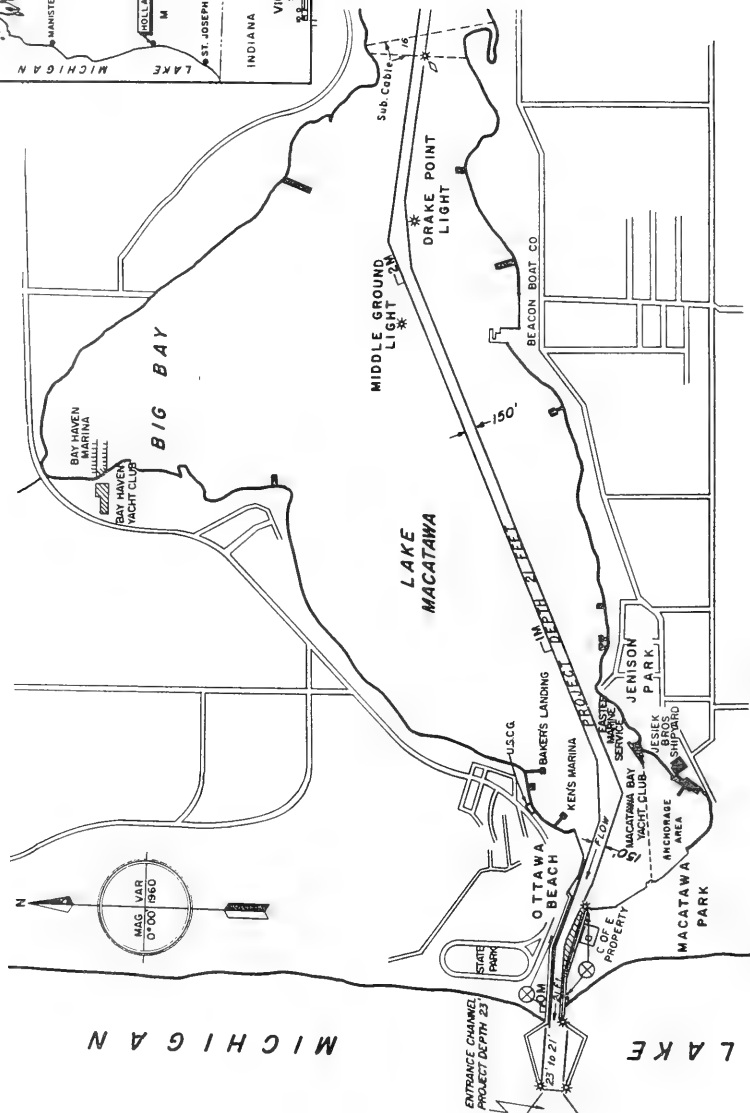
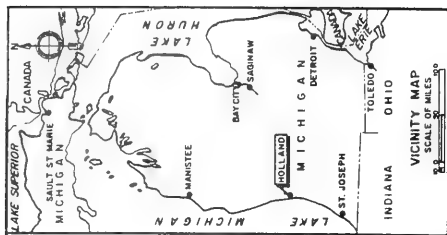
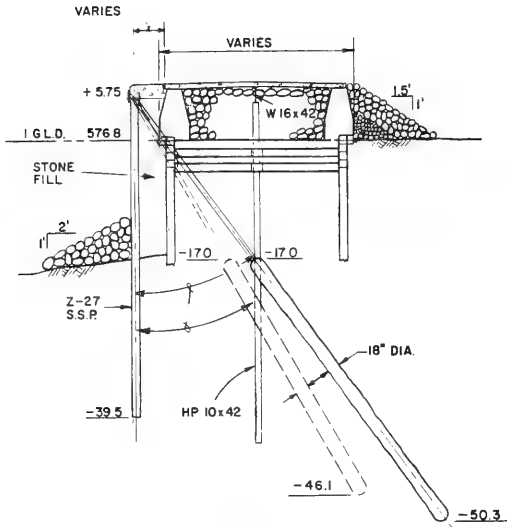
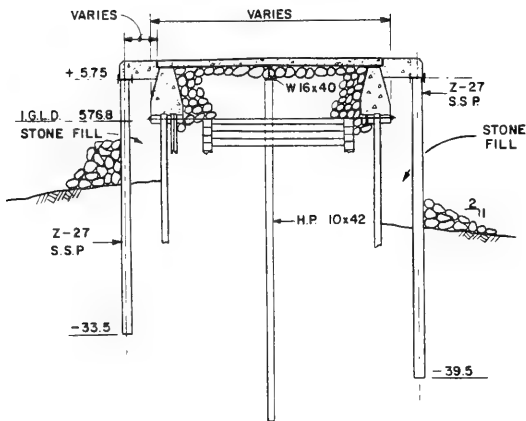


Figure 122. Holland Harbor, Michigan





TYPICAL SEC.-J



TYPICAL SEC.-I

Figure 124. Typical structure cross sections, Holland Harbor, Michigan

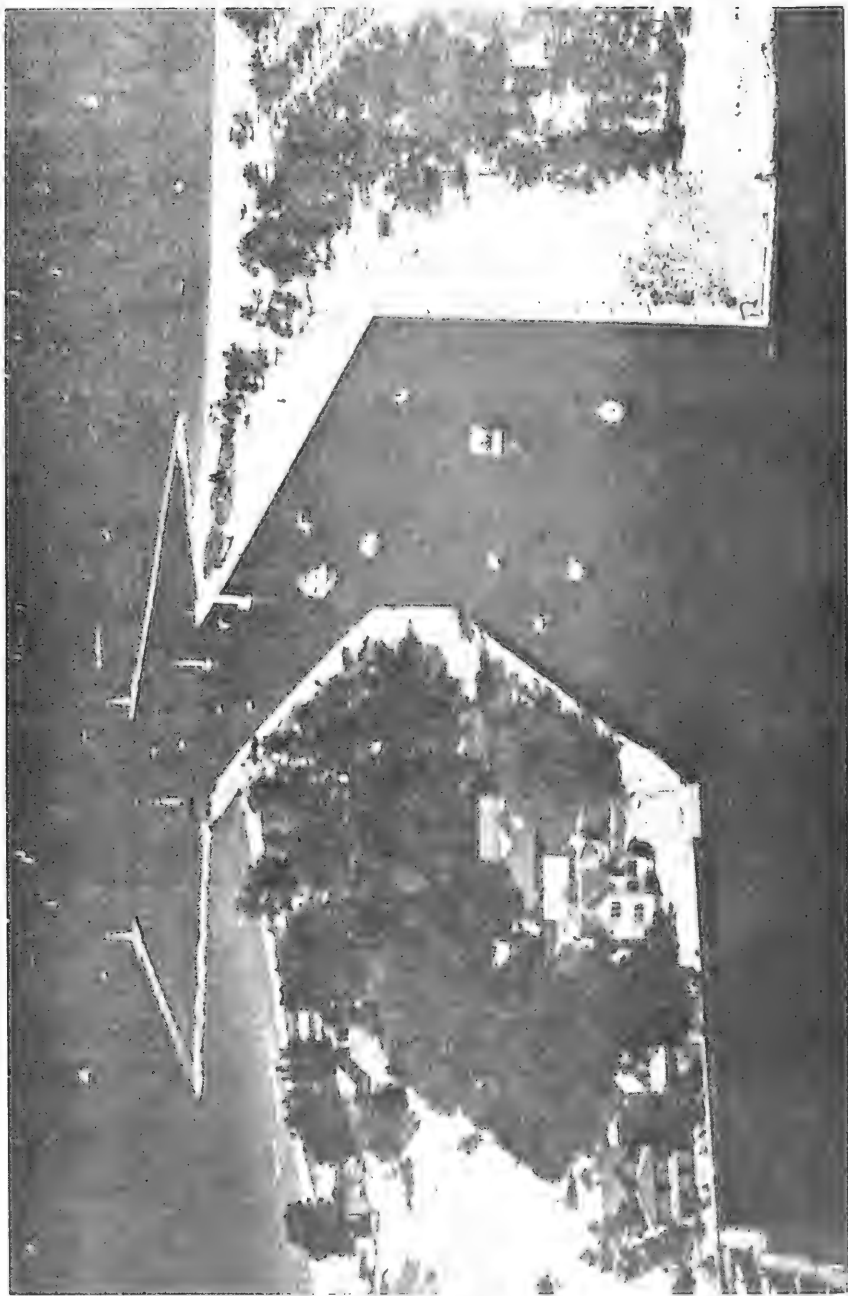


Figure 125. Aerial view of Holland Harbor, Michigan

Table 47

Grand Haven Harbor Piers  
Grand Haven, Michigan

Date(s)	Construction and Rehabilitation History
1867- 1869	Construction of the shoreward 396 ft of the south pier (Figure 126, Sections K, J1, and J) was completed during this period. The pier consisted of timber piling spaced approximately 30 ft apart and filled with stone (Figure 128, Sections K, J1, and J).
1875- 1879	Construction of the shoreward 605 ft of the north pier (Figure 126, Section B) was completed during this time. The pier was constructed with a 30-ft-wide stone-filled timber crib structure (Figure 127, Section B).
1882- 1887	The south pier was extended by 1,000 ft (Figure 126, Sections H1 and I). This extension consisted of stone-filled timber crib structures (Figure 128, Sections H1 and I) built on a stone base. The cribs were about 30 ft wide.
1887- 1894	The south pier was extended by 119 ft (Figure 126, Section H) and the north pier by 811 ft (Figure 126, Sections A, A1, and A2) during this time. The extensions were constructed with stone-filled timber cribs on stone bases (Figure 127, Sections A, A1, and A2; and Figure 128, Section H). The width of the structures were 30 ft.
1916- 1922	The north and south piers (Figure 126) were capped with stone and concrete superstructures during this period. The north pier (Figure 127, Sections A, A1, A2, and B) ranged in el from +7.1 to +8.0 ft lwd, and the south pier (Figure 128, Sections H, H1, I, J, J1, and K) had a crest el ranging from +6.3 to 9.1 ft lwd.
1952- 1960	The north and south piers (Figure 126) were repaired during this time. The existing structures were encased in steel sheetpiling (Figures 127 and 128). The voids between the sheetpiling and the existing structures were filled with gravel or stone, and the pier edges were capped with concrete. The north pier ranged from about 34 to 36 ft in width (Figure 127, Sections A, A1, A2, and B), and the south pier was from 37 to 51.5 ft in width (Figure 128, Sections H, H1, I, J, J1, and K).
1976	Riprap stone was placed along the outer 210 ft of the lakeside portion of Section H-I (Figure 126) of the south pier. Fill stone also was replenished in the cells of Section K of the south pier, and they were capped with concrete.
1980	Riprap was placed along portions of the north (Figure 126, Sections A and A1) and south (Sections J, J1, and H) piers.

(Continued)

Table 47 (Concluded)

Date(s)	Construction and Rehabilitation History
1983	Additional riprap stone was placed along the north (Figure 126, Sections A and A1) and south (Section H) piers.
1985	A site inspection indicated the structures were generally in very good condition. An aerial photo of the Grand Haven Harbor Piers is shown in Figure 129.

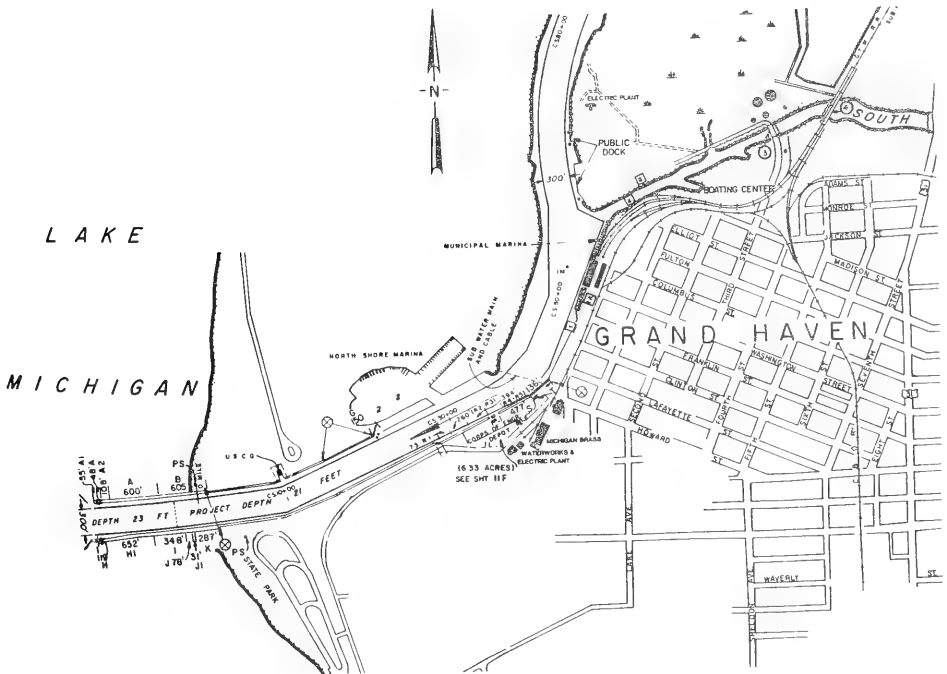


Figure 126. Grand Haven Harbor, Michigan

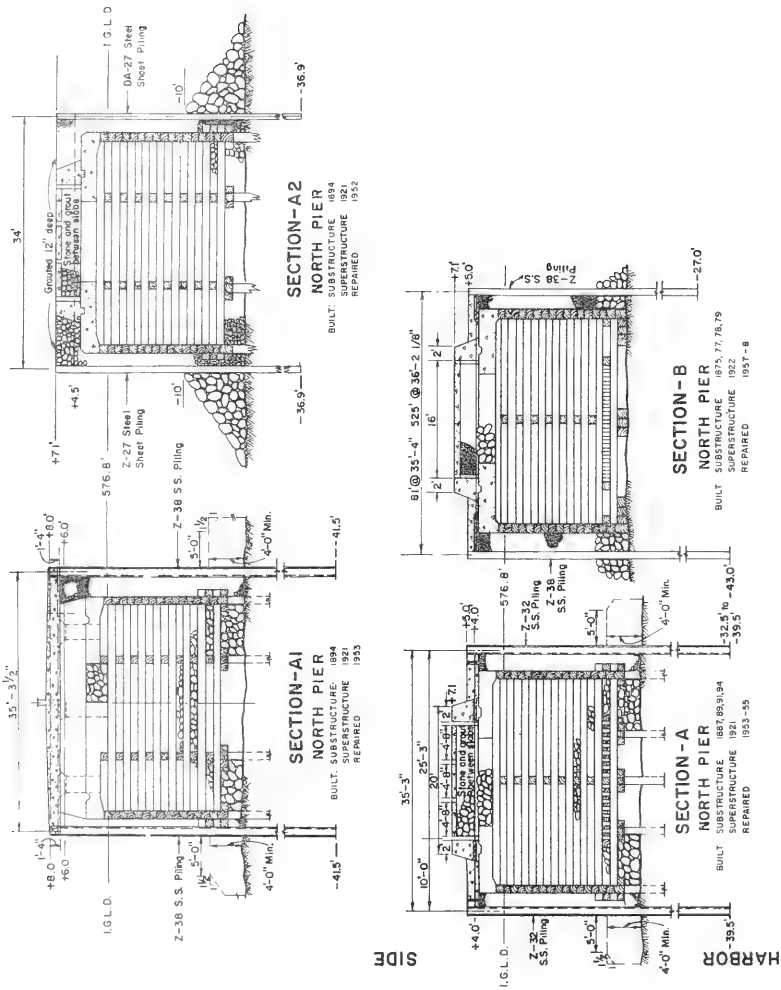


Figure 127. Typical north pier cross sections, Grand Haven Harbor, Michigan



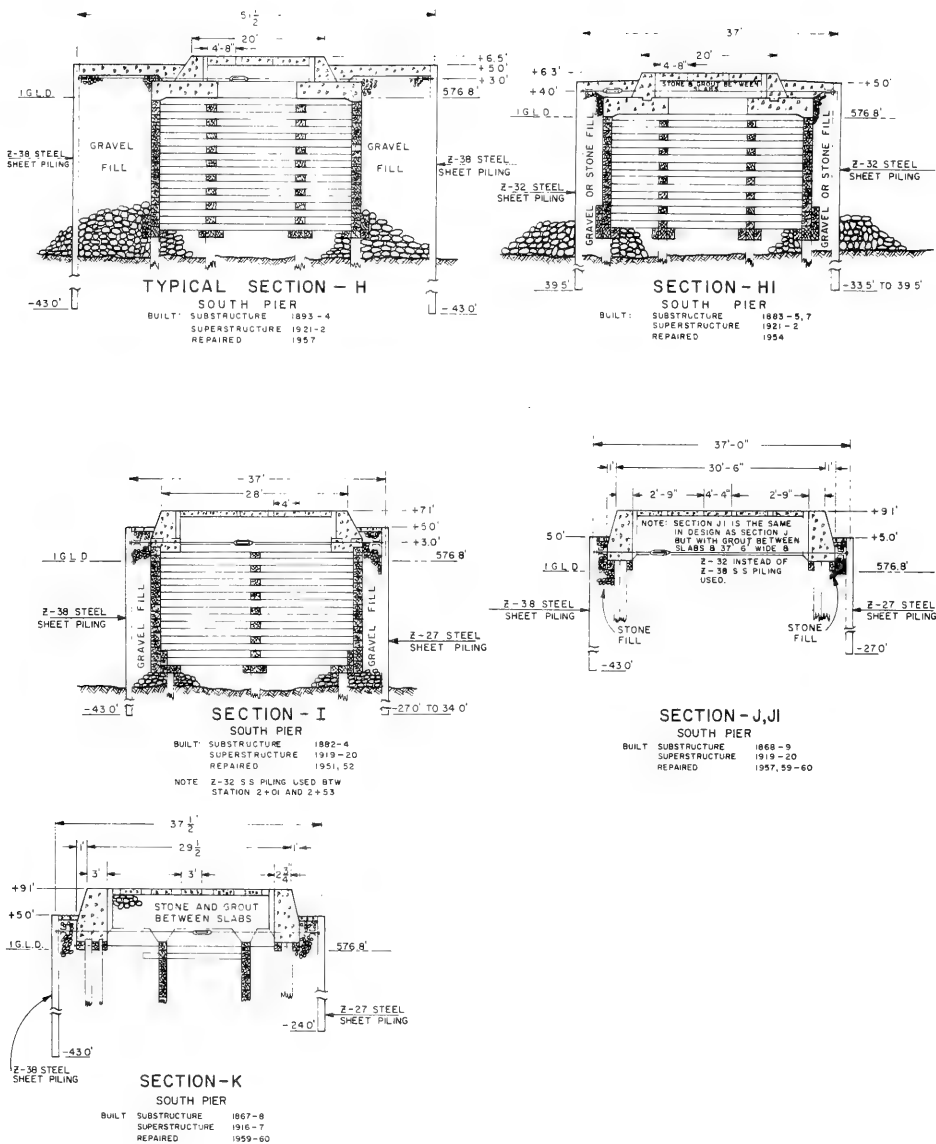


Figure 128. Typical south pier cross sections, Grand Haven Harbor, Michigan



Figure 129. Aerial view of Grand Haven Harbor, Michigan

Table 48

Muskegon Harbor StructuresMuskegon, Michigan

Date(s)	Construction and Rehabilitation History
1868- 1890	Construction of a 703-ft-long north pier and a 692-ft-long south pier (Figure 130) was completed during this time. The piers were originally built with woodpilings and ranged from 18 to 32 ft in width. The area between the pilings was filled with stone and timber, and the piers were capped with a timber superstructure.
1906	The north pier was rebuilt with timber pilings similar to the original construction.
1927- 1931	Construction of the north and south breakwaters (Figure 130) was completed. (Figures 130, 131, and 132 illustrate structures at Muskegon Harbor.) The north breakwater was a rubble-mound structure (Figure 132, Sections A and B) that was capped with 8- to 10-ton armor stone (Section A) with the exception of the shoreward end (Section B) which had 1- to 5-ton armor protection. The crest el of the structure was about +8.5 ft lwd, and side slopes were 1V:1.5H. The lakeward portion of the south breakwater (Figure 132, Sections C, D, and E) was constructed with stone-filled concrete caissons on woodpilings. These structures had concrete caps that were 7.3 ft wide at the crest with an el of +7.1 ft lwd. The shoreward portion of the south breakwater (Figure 132, Sections F, G, and H) was composed of woodpiling with a stone fill and concrete and stone superstructures. The structures ranged from 14 to 17 ft in width and had crest els ranging from +7.1 to +7.4 ft lwd. The outer 54 ft of the south breakwater consisted of two rectangular stone-filled concrete caissons. Riprap with a 1-V:2-H side slope was placed along the sides of most of the structure.
1932- 1934	The north and south pier superstructures were rebuilt and consisted of concrete and stone construction (Figure 131, Sections N, O, and P).
1942- 1954	During this period a total of 16,757 tons of riprap stone was placed along the sides of the south breakwater (Figure 132, Sections C, D, E, F, and G).
1960- 1963	An additional 4,832 tons of riprap was placed along the south breakwater at Sections E and F (Figure 130).
1966	The south pier (Figure 130, Sections N, O, and P) was rehabilitated by encasing it in steel sheetpiling. The voids were filled between the sheetpiling and the existing structure, and the pier was capped with concrete. The new el was +8.5 ft lwd, and the width ranged from 35 to 45 ft. A portion of the south breakwater (Figure 130, Sections F and G) was rehabilitated also. Fill-stone replenishment and regrouting of the superstructure was accomplished, and additional riprap stone was placed along the shoreline.

(Continued)

Table 48 (Concluded)

Date(s)	Construction and Rehabilitation History
1975	Stone was placed along the lakeward end of the north breakwater (Figure 130, Section A) in areas of settlement and along the lakeward end of the south breakwater (Figure 130, Section D) for protection against wave and ice action.
1979- 1980	The entire north pier (Figure 130) was removed, and the structure was replaced with a rubble-mound pier (Figure 131). The crest el of the pier was +8.5 ft lwd, and side slopes were 1V:2.5H on the channel side and 1V:1.5H on the lakeside. Approximately 1,000 tons of stone was placed along the navigation light at the head of the north breakwater. Riprap stone also was placed along the south breakwater head.
1981	Approximately 510 tons of riprap stone was again placed at the head of the north breakwater around the navigation light (Figure 130). Riprap also was again placed around the head of the south breakwater. Fill stone in the entire south pier (Figure 130, Sections N, O, and P) was replenished, and the structure was recapped with concrete.
1982	The stone at the head of the west breakwater (Figure 130) again was washed out, and approximately 1020 tons of 8- to 16-ton riprap stone was placed around the navigation light. Also added were 50 tons of 3- to 10-in. fill stone, 247 tons of 50- to 300-lb core stone, and 312 tons of 500-lb to 3-ton riprap to the north breakwater (Figure 130, Section A). Repairs to the head of the south breakwater (Section C) included the addition of 324 tons of 500-lb to 3-ton riprap as core stone along the lakeside face and 1,038 tons of 3- to 16-ton riprap around the breakwater head. In addition, 800 tons of 500-lb to 3-ton riprap stone was placed as toe protection along the channel side of the south pier.
1983	The north pier (Figures 130 and 131) was repaired with the placement of larger cover stone, and 8- to 12-ton riprap stone was placed around the navigation light at the head of the west breakwater (Figure 130).
1984	Major riprap placement at the south breakwater (Figure 130, Sections C, D, and E) for protection against waves and ice action was completed which involved approximately 86,770 tons of 10- to 26-ton cover stone (with stones as large as 49 tons in some areas). This placement encompassed the south breakwater head and both the lake and harbor sides. The stone was placed to an el of +8.0 ft lwd.
1986	Reconstruction of the head of the north breakwater was initiated and involved (Figure 130) removal of the existing cover and core stone and the placement of a steel sheetpiling with a concrete cap breakwater head structure. Also initiated was rehabilitation of the south breakwater concrete caps which are extensively spalled with large pieces cracked and broken off causing a hazard to the public. After these repairs, the structures will be in good condition. An aerial view of Muskegon Harbor structures is shown in Figure 133.

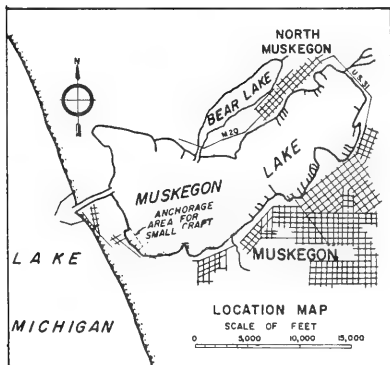
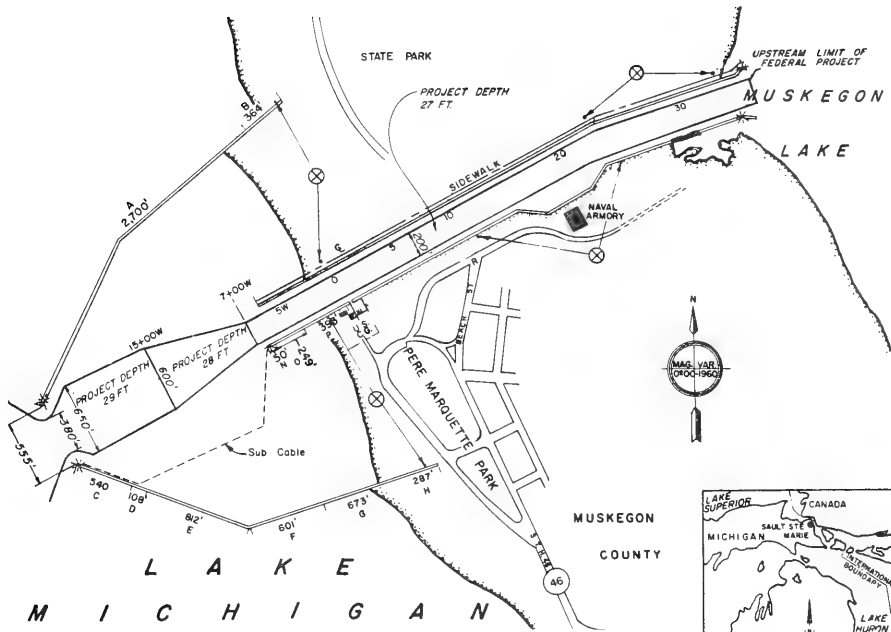


Figure 130. Muskegon Harbor, Michigan

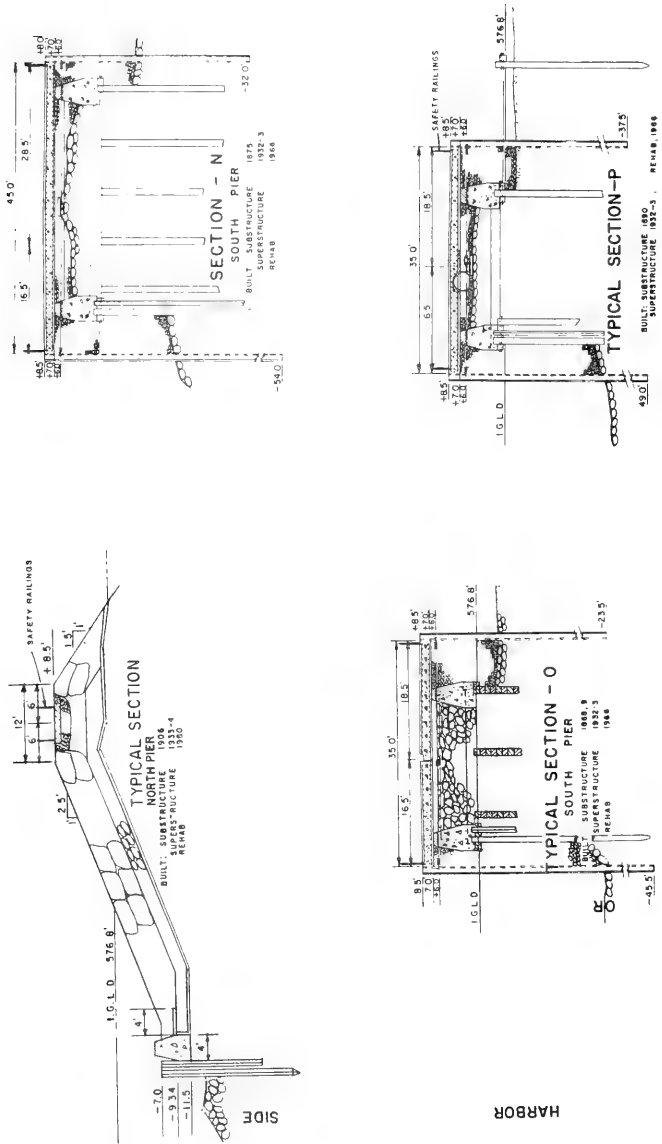


Figure 131. Typical structure cross section, Muskegon Harbor, Michigan





Figure 133. Aerial view of Muskegon Harbor, Michigan



Table 49

White Lake Harbor Piers  
White Lake, Michigan

Date(s)	Construction and Rehabilitation History
1870-1872	A 495-ft-long north pier was constructed at the site (Figure 134, Section G) during this time frame. The pier was constructed of woodpilings driven from 21 to 29 ft apart and filled with stone (Figure 135, Section G).
1899	A 673-ft-long south pier (Figure 134, Sections C, D, and E) was constructed. The inner 369 ft was constructed with woodpilings (Figure 135, Sections D and E). The piers were stone filled and ranged in width from 22 to 26.5 ft. The outer 304-ft-long portion (Figures 134 and 135, Section C) consisted of a stone-filled timber crib structure that ranged from 28 to 30 ft in width.
1900	The north and south piers were extended by 200 and 150 ft, respectively (Figure 134, Sections A and B). The extensions were stone-filled timber crib structures and were built on a stone base (Figure 135, Sections A and B). The north pier (Section A) was 24 ft in width, and the south pier (Section B) was 34 ft wide.
1936-1937	The north and south piers were capped with concrete and stone superstructures (Figure 135, Sections A-E and G). The crest els of the pier were +7.0 ft lwd.
1971	Fill stone was replenished in the shoreward portion of the north pier (Figure 134, Section G). An underwater examination of the lakeside of the south pier revealed signs of deterioration of the timber piling along Sections C and D (Figure 134) and fill stone being washed out between these pilings.
1982	Fill stone was replenished in the lakeward portion (Figure 134, Section A) of the north pier and the south pier (Figure 134, Section B). Riprap stone around the head of the south pier (Section B) also was placed.
1983	Riprap stone around the heads and along the lake and channel sides of Section A (Figure 134) was placed. In addition, stone fill was again placed in open pockets of the superstructures of this portion of the pier and grouted over.
1985	An inspection of the structures indicated that the substructures of both piers are deteriorating, resulting in superstructure settlement and cracking, considerable misalignment and tilt, and loss of fill stone. Both structures are considered to be in poor condition. Reconstruction and/or rehabilitation has been recommended within the next 2 to 3 years.



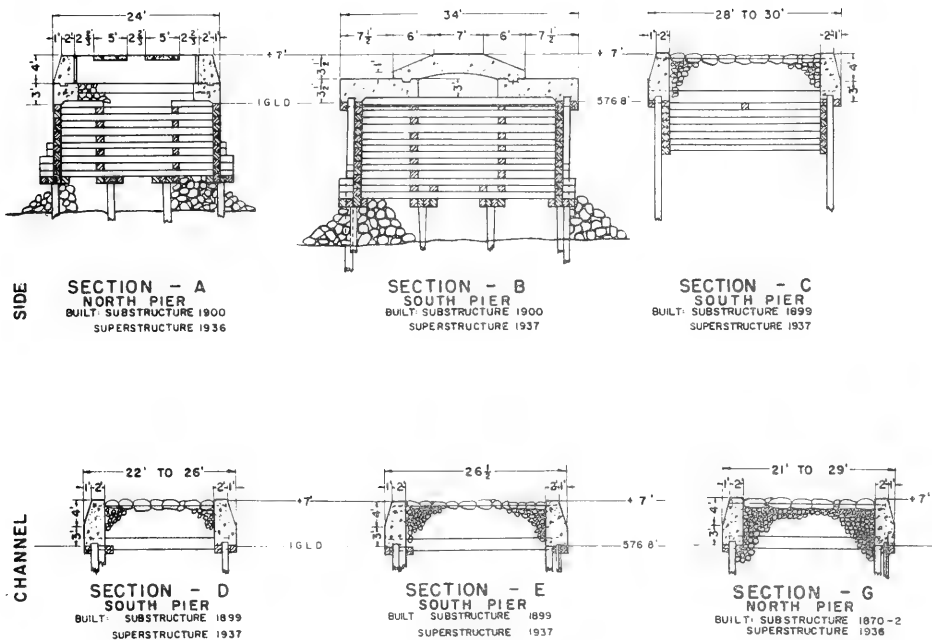


Figure 135. Typical pier cross sections, White Lake Harbor, Michigan

Table 50

Pentwater Harbor PiersPentwater, Michigan

Date(s)	Construction and Rehabilitation History
1868- 1870	Construction of a 606-ft-long north pier (Figure 136, Sections B, C, D, and E) and a 620-ft-long south pier (Figure 136, Sections B, H, and J) was completed during this period. The shoreward 439 ft of the north pier was constructed with woodpilings (Figure 137, Sections D and E) that were spaced 14 ft apart and stone filled. The remaining portions of the north pier and the entire south pier (Figure 137, Sections B, C, J, and H) were constructed with stone-filled timber crib structures. The width of the timber cribs at the north pier (Sections B and C) were 20 ft, and the south pier timber crib structures (Sections B, H, and J) ranged from 20 to 32 ft in width.
1872	The north pier was extended by 34 ft (Figure 136, Section A) with a timber crib structure. The pier extension was 30 ft wide and filled with stone (Figure 137, Section A).
1887	The south pier was extended by 101 ft (Figure 136, Section G). The extension included a 30-ft-wide stone-filled timber crib structure (Figure 137, Section G).
1938	The north and south piers were capped with concrete and stone superstructures (Figure 137). The crests of the piers were installed at an el of +7.0 ft lwd. The piers ranged in width from 18 to about 37.5 ft. The widths of two portions of the north pier (Figure 137, Sections A and C) were increased by installing woodpilings on the channel side and filling the voids with stone prior to capping the structures.
1959	A 60-ft-long rubble-mound extension to the north pier was completed (Figure 136). The structure had a 10-ft-wide crest width and an el of +5.0 ft lwd (Figure 137). Side slopes were 1V:2H, and 9-ton (min) toe stones were utilized.
1971	Riprap stone was placed around the head and on the lakeward side of the rubble-mound portion of the north pier (Figure 136), and stone replenishment and regrouting was completed for the remaining portion of the north pier (Sections A, B, C, and D). Riprap also was placed around the head of the south pier, and fill stone placement and regrouting were completed for Section B (Figure 136) of the south pier.
1981	Riprap was placed along the lakeside of a portion of the south pier (Figure 136, Section H).
1982	Small core stone was placed into gaps of the rubble-mound portion of the north pier (Figure 136) between the cover stones. Fill stone

(Continued)

Table 50 (Concluded)

Date(s) Construction and Rehabilitation History

replenishment and concrete capping were completed to Sections A, B, C, D, and E of the north pier and Section G of the south pier (Figure 136).

1985 A site inspection of the structures indicated that the rubble-mound extension of the north pier (Figure 136) has settled up to 1 ft throughout. The remaining portions of the north pier (Sections A, B, C, D, and E) and the south pier (Sections G, H, B, and J) are bulging, tilting, leaning, cracked and misaligned. These factors, along with loss of fill stone, indicate substructure deterioration. The structures are considered in poor condition; however, major rehabilitation has been recommended and is scheduled for 1987. An aerial view of the Penwater Harbor piers is shown in Figure 138.

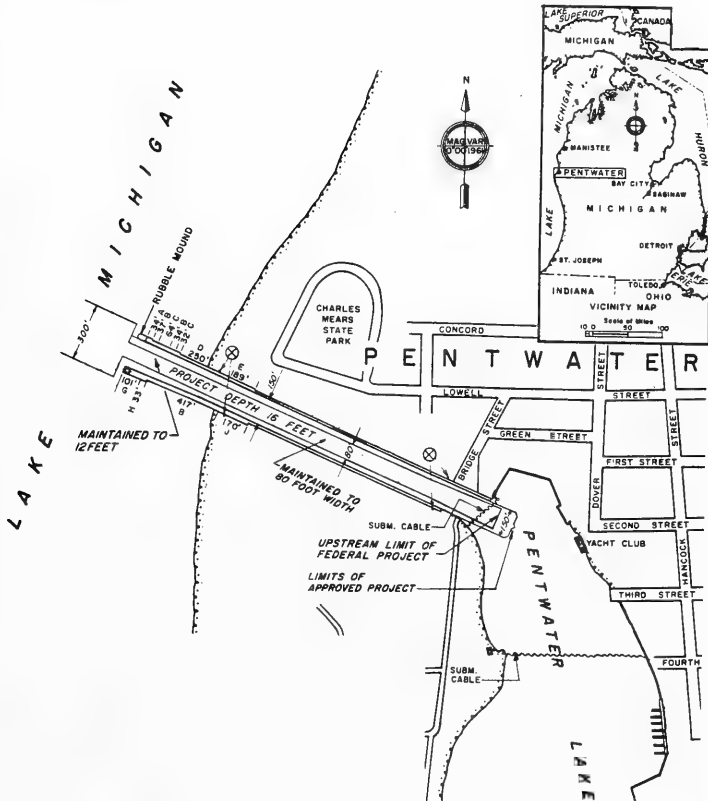
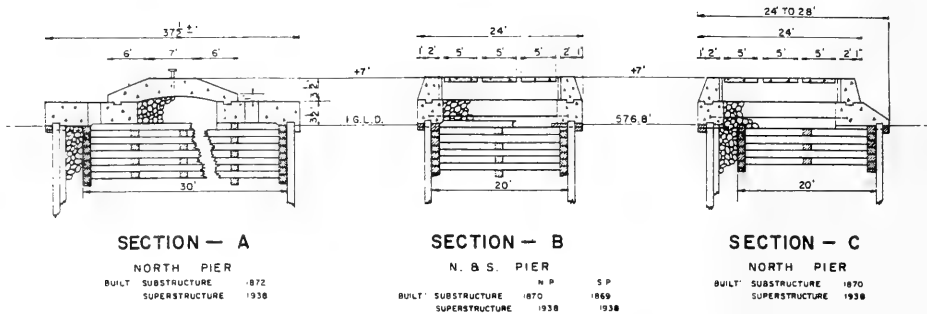
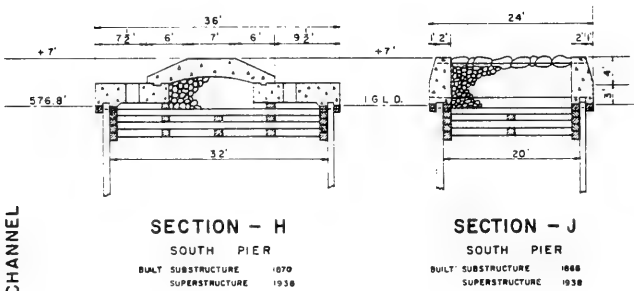
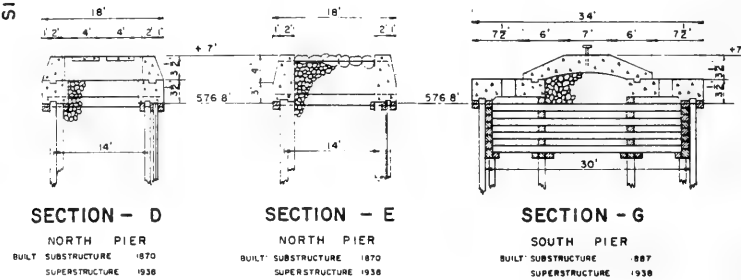


Figure 136. Pentwater Harbor, Michigan



SIDE



CHANNEL

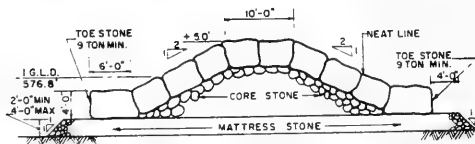


Figure 137. Typical structure cross sections, Pentwater Harbor, Michigan



Figure 138. Aerial view of Pentwater Harbor, Michigan

Table 51  
Ludington Harbor Structures  
Ludington, Michigan

<u>Date(s)</u>	<u>Construction and Rehabilitation History</u>
1866- 1874	Construction of a north (Figure 139 Sections J and J1) and south (Figure 139, Sections L, M, and N) pier was completed during this period. The north pier consisted of stone-filled timber cribs about 20 ft in width (Figure 140, Sections J and J1). The south pier originally consisted of stone-filled 20-ft-wide timber cribs (Figure 139, Sections L and M) and woodpilings (Figure 137, Section N) spaced about 20 ft apart and filled with stone.
1879- 1880	The north pier was extended (Figure 139, Sections G and H) by 311 ft. The extension involved the construction of stone-filled timber cribs (Figure 140, Sections G and H) with a width of about 24 ft.
1907- 1914	Construction of the north and south breakwaters (Figure 139) was completed in this time frame. The lakeward portions of the breakwaters (Figures 139, 141, and 142, Sections A, B, C, D, and E) were constructed with stone-filled timber cribs with a width of 30 ft. The structures were built on a stone base. The shoreward portions of the breakwaters (Figures 139 and 142, Sections F and F1) were constructed with woodpiling with widths ranging from 12 to 20 ft.
1922- 1929	The north pier (Figures 139 and 140, Sections G, H, J, and J1), the south pier (Figure 139, Sections L, M, and N) and the lakeward portions of the north (Figures 139 and 141, Sections A and B) and south (Figures 139 and 142, Sections C and D) breakwaters were capped with stone and concrete superstructures during this period. The crest els of the north and south piers were +6.0 ft lwd, and those of the north and south breakwaters were approximately +7.1 and +6.75 ft lwd, respectively.
1936- 1937	The shoreward portions of the north and south breakwaters (Figures 139, 141, and 142, Sections C, F, and F1) were capped with stone and concrete superstructures. The crest els of these structures ranged from about +6 ft to +7.1 ft lwd.
1954- 1964	The north pier (Figure 139, Sections G, H, J, and J1) and the lakeward end of the south breakwater (Figure 139, Sections D and E) were repaired during this time. The north pier was encased with steel sheetpiling. The lakeward portion of the pier (Figure 140, Sections G, H, and J) included gravel fill and a concrete cap. The repaired pier was about 32 ft wide and had a crest el ranging from +7.0 ft lwd (Section G) to +7.5 ft lwd (Sections H and J). The shoreward portion of the pier (Figure 140, Section J1) was stone filled on the channel side with a concrete cap. The structure was backfilled with sand at an el of +6.0 ft lwd. Repairs to the south

(Continued)



Table 51 (Concluded)

Date(s)	Construction and Rehabilitation History
	breakwater (Figure 142, Sections D and E) involved the placement of new core stone over the existing riprap and cover stone on each side of the structure. The cover stone was 8 tons (minimum 10-ton average) with a crest el of +3.0 ft lwd and side slopes of 1V:1.5H.
1970- 1971	Portions of the north and south breakwaters (Figure 139, Sections A, B, C, and F1) were repaired. The lakeward portion of the north breakwater (Figure 141, Sections A and B) included the placement of new core stone over the existing riprap and 8-ton minimum to 10-ton maximum cover stone with an el of +3.0 ft lwd on each side of the breakwater and 1-V:1.5-H side slopes. Repairs to Sections C and F1 of the north breakwater and Section F1 of the south breakwater (Figures 141 and 142) included core stone and 8- to 12-ton cover stone on the lakeside of the structures with an el of +3.0 ft lwd and 1-V:1.5-H side slopes. Toe stone on each side of the breakwaters ranged from 10 to 15 tons.
1974- 1975	A hydraulic model investigation was conducted (Crosby and Chatham 1975) to determine optimum design features at the breakwater entrance which would allow the passage of larger and deeper draft vessels while still providing wave protection at the existing docking facilities.
1977- 1981	The south pier (Figure 139, Sections L, M, and N) was reconstructed. The new pier consisted of a rubble-mound structure with a concrete cap which ranged from 9.5 to 11 ft in width (Figure 143, Sections L, M, and N) and had a crest el of +7.0 ft lwd. The lakeward portion of the pier included 3- to 6-ton cover stone (Sections L and M), and the remaining portion had 100- to 250-lb cover stone. Side slopes of the pier were 1V:1.75H. A wave absorber was installed adjacent to the north pier (Figure 140) with a slope of 1V:1.5H and an el of +7.0 ft lwd. Cover stone ranging from 2.5 to 5 tons was utilized.
1985	Site inspection of the structures indicated that they were generally in fair condition with the breakwater caps in need of maintenance. An aerial view of the Ludington Harbor structures is presented in Figure 144.



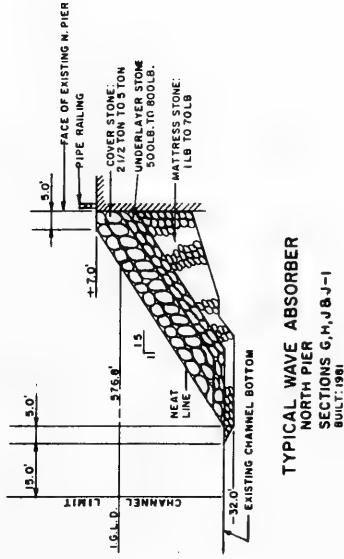
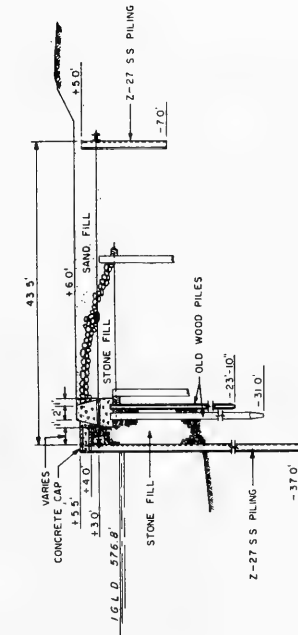
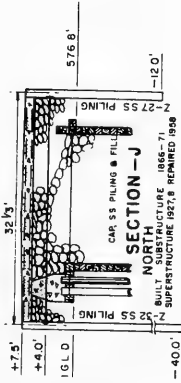
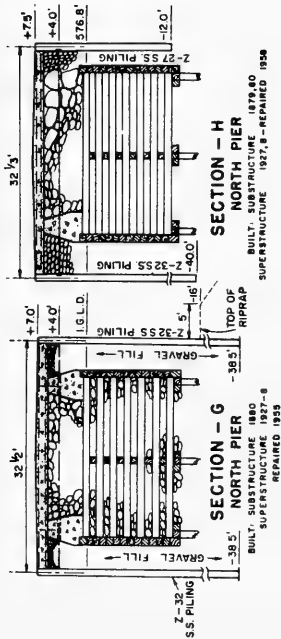
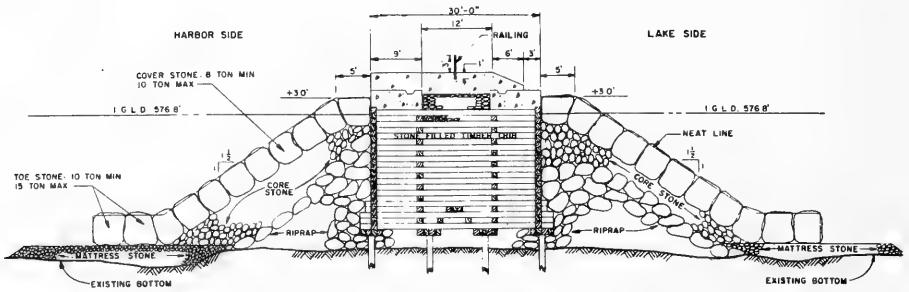
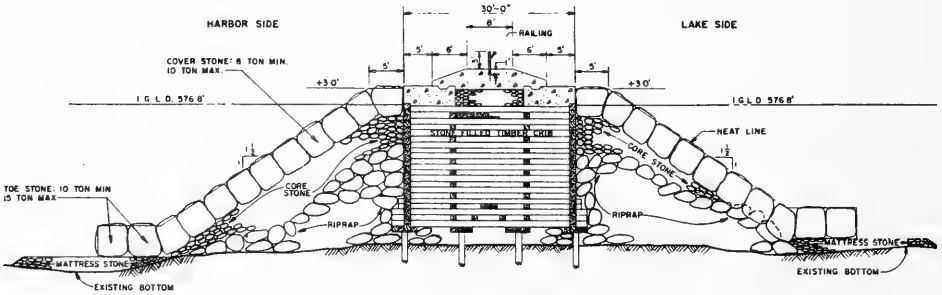


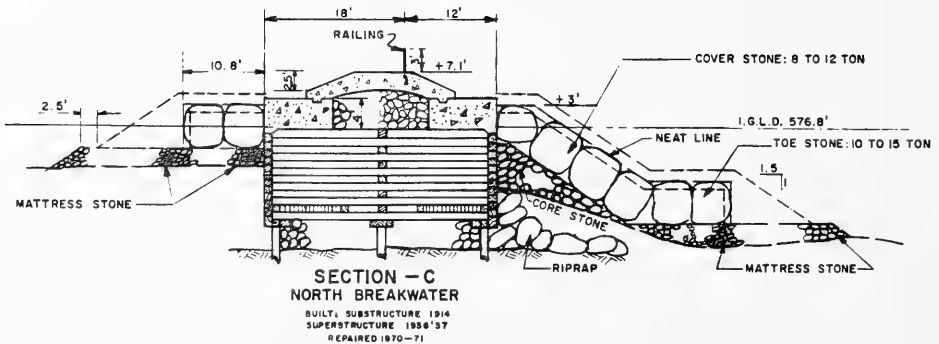
Figure 140. Typical structure cross sections, Ludington Harbor, Michigan



**TYPICAL SECTION A**  
**NORTH BREAKWATER**  
 BUILT: SUBSTRUCTURE 1909  
 SUPERSTRUCTURE 1922, 4  
 REPAIRED 1970-71

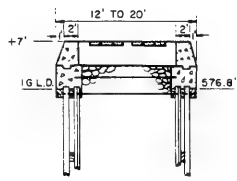
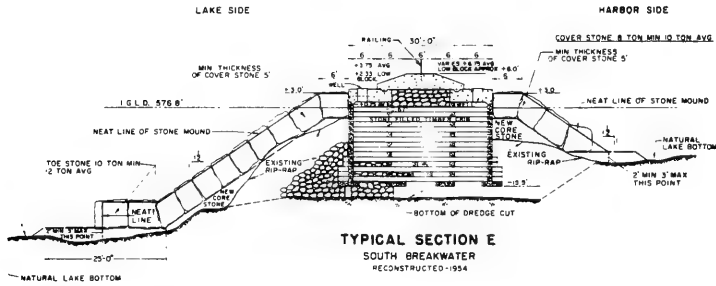
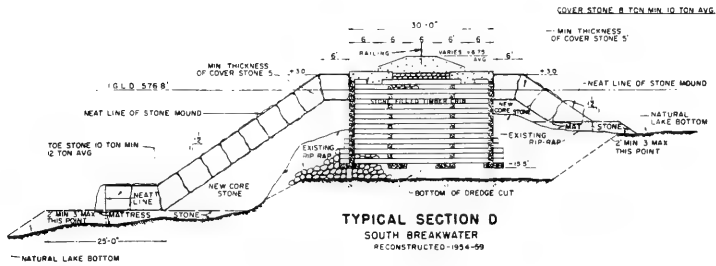


**TYPICAL SECTION B**  
**NORTH BREAKWATER**  
 BUILT: SUBSTRUCTURE 1909-11  
 SUPERSTRUCTURE 1924  
 REPAIRED 1970-71



**SECTION - C**  
**NORTH BREAKWATER**  
 BUILT: SUBSTRUCTURE 1914  
 SUPERSTRUCTURE 1958-'57  
 REPAIRED 1970-71

Figure 141. Typical north breakwater cross sections, Ludington Harbor, Michigan



**TYPICAL SECTION - F**  
N. & S. BREAKWATER

	N	S
BUILT: SUBSTRUCTURE	1914	1913-4
SUPERSTRUCTURE	1936-7	1936-7

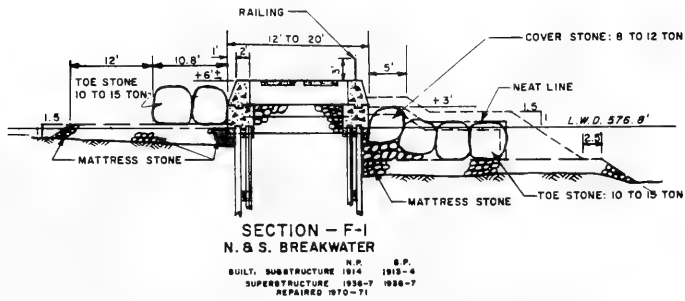


Figure 142. Typical breakwater cross sections, Ludington Harbor, Michigan

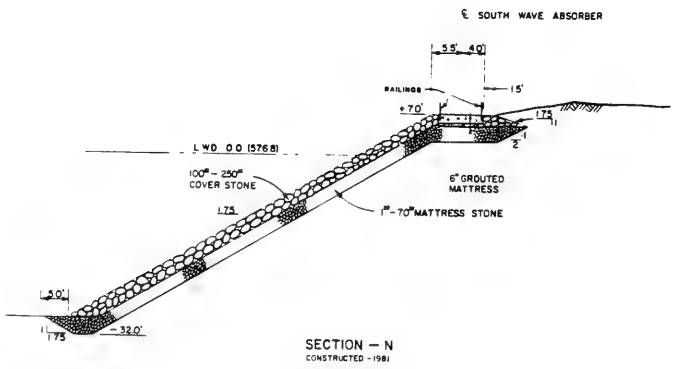
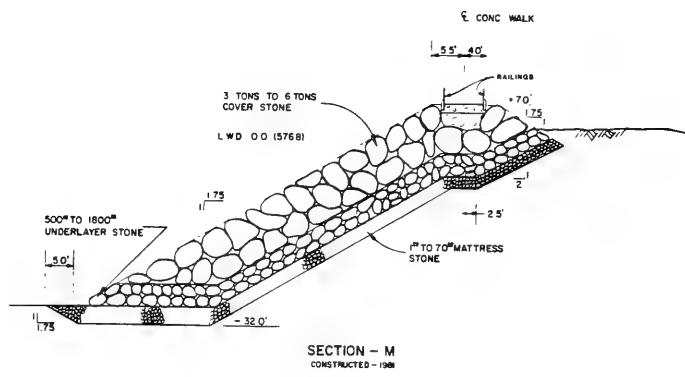
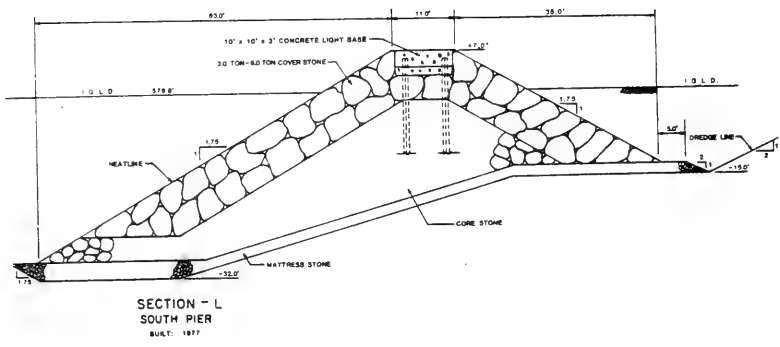


Figure 143. Typical structure cross sections, Ludington Harbor, Michigan



Figure 144. Aerial view of Ludington Harbor, Michigan

Table 52

Manistee Harbor StructuresManistee, Michigan

Date(s)	Construction and Rehabilitation History
1912- 1915	Construction of the lakeward portions of the north pier (Figure 145, Sections A-1, A, B, C, D, and E) and the south breakwater (Figure 145, Sections B-1 and B) was completed during this time. These structures consisted of stone-filled timber cribs. The width of the north pier ranged from 24 to 30 ft (Figure 146), and that of the south breakwater was 30 ft (Figure 147, Sections B and B-1).
1917- 1920	Construction of the shoreward portion of the south breakwater (Figure 145, Sections M, N, O, O-1, P, and Q) was completed. The breakwater consisted of stone-filled woodpilings spaced from 9 to 17 ft apart (Figure 147). The breakwater was capped with a stone and concrete superstructure (Figure 147) that ranged from +5.7 ft (Section P) to +6.7 ft (Sections M, N, O, and O-1) lwd.
1926	The lakeward end of the north pier (Figure 145, Sections A1-A, and B) was capped with a concrete and stone superstructure (Figure 146, Sections A, A-1, and B). The crest el of the pier was +7.1 ft lwd.
1933- 1935	The lakeward end of the south breakwater (Figure 145, Sections B and B1) and the shoreward end of the north pier (Figure 145, Sections C, D, and E) were capped with concrete and stone superstructures. The crest el of the structures was +7.1 ft lwd (Figures 146 and 147).
1942	A 350-ft-long shoreward extension of the north pier (Figure 145, Section F) was constructed. The extension consisted of woodpilings filled with stone (Figure 146, Section F). A concrete superstructure was installed on the channel side to an el of +6.0 ft lwd.
1949- 1950	Construction of the south pier (Figure 149, Section J) was completed. This structure consisted of steel sheetpiling spaced 15.7 ft apart and filled with stone (Figure 146, Section F). The crest el of the pier was +7.0 ft lwd.
1953	The north pierhead (Figure 145, Section A-1) was rebuilt by encasing it in steel sheetpiling. The structure width was increased to 35.3 ft, voids were filled with stone, and a concrete cap was installed at a crest el of +8.0 ft lwd (Figure 146, Section A-1).
1964- 1966	Portions of the north pier (Figure 145, Sections A-F) and the south breakwater (Sections B1, M, N, O, O-1, and P) were rehabilitated during this time. Sections C through E of the north pier (Figure 146) were encased with steel sheetpiling which resulted in pier widths ranging from about 31 to 38 ft. Voids were filled with stone, and a concrete cap was installed at an el of +8.0 ft lwd. Section F

(Continued)



Table 52 (Concluded)

Date(s)	Construction and Rehabilitation History
	<p>(Figure 146) of the north pier was enclosed in steel sheetpiling with a concrete cap from the channel piling to the existing concrete and stone fill from that point shoreward. The el of this section was +6.0 ft lwd. Rehabilitation to Sections M, N, O, and O1 of the south breakwater (Figure 147) involved the placement of stone to each side of the breakwater. Stone was placed to an el of +2.0 ft lwd with 1V:1.5H side slopes. Cover stone ranging from 5 (min) to 7 tons (max) was placed adjacent to Sections M and N, while cover stone ranging from 1.5 (min) to 2.5 tons (max) was placed adjacent Section O and O-1. Stone was placed only on the lakeside of Sections P and B1 (Figure 147). Cover stone ranging from 7 (min) to 10 tons (max) was used at the pierhead (Section B1), while 0.5-ton riprap was placed adjacent to Section P. Side slopes were 1V:1.5H, and crest els were +2.0 ft lwd.</p>
1980	<p>Approximately 1,016 tons of riprap (0.5 to 4 tons) was placed along the channel side of the north pier to reduce scouring, and about 110 tons of stone fill was placed in the cells of the south breakwater.</p>
1982	<p>Riprap (2,024 tons) ranging from 3 to 16 tons was placed along the lakeside of the south breakwater, and about 2,545 tons of 0.5- to 3-ton riprap was installed on the channel side of the structure as toe protection. A total of 529 tons of riprap was placed along the channel side of the north pier as toe protection. This stone ranged from 0.5 to 3 tons in weight. Stone fill was replenished at the head of the south breakwater and on the channel side of the south pier also during this year.</p>
1985	<p>An inspection of the structures revealed them to be, generally, in fair condition. Minor settlement and cracking of the concrete cap was observed along the north pier indicating some fill stone settlement. Loss of fill stone and superstructure misalignment, settlement, and cracking indicates substructure deterioration of the south breakwater. Repairs consisting of stone replenishment and new concrete caps along with additional riprap within the next 2 years have been recommended. An aerial photo of Manistee Harbor structures is shown in Figure 148.</p>



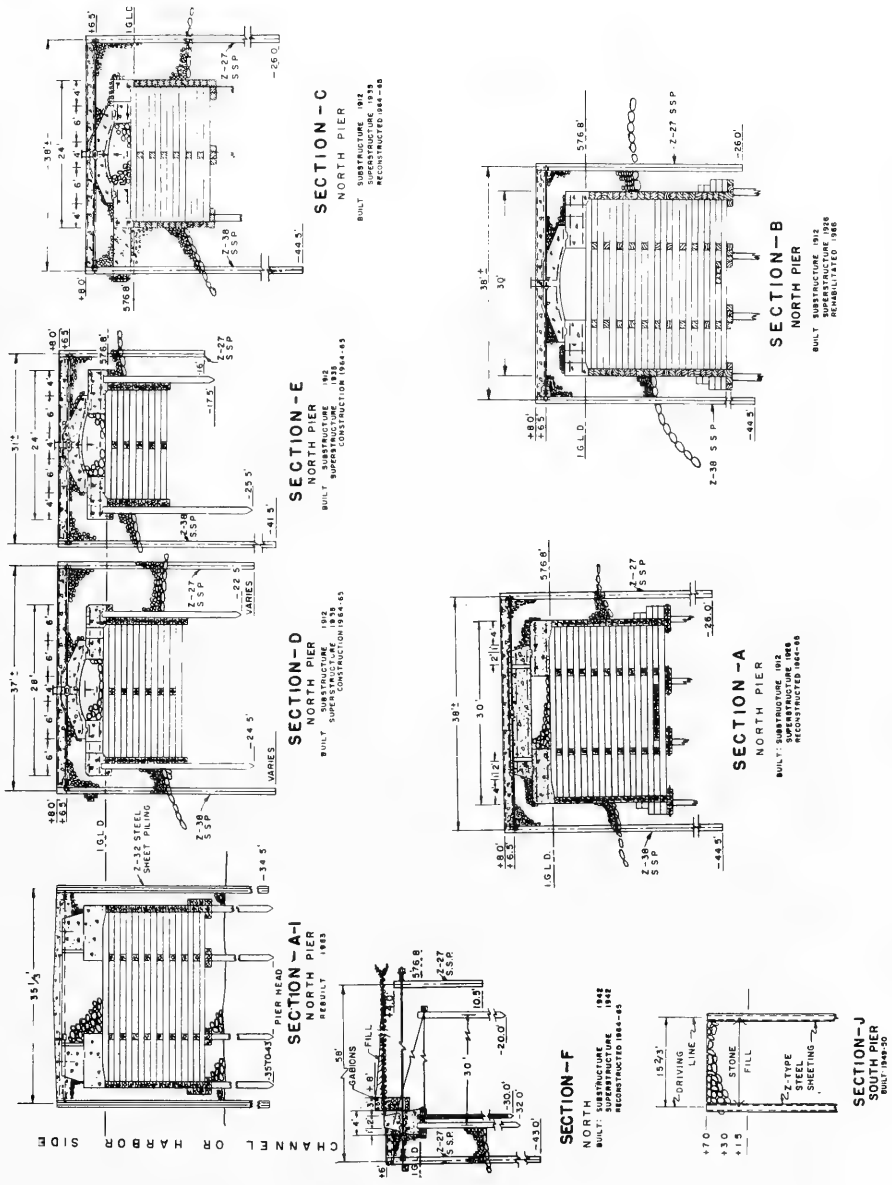


Figure 146. Typical pier cross sections, Manistee Harbor, Michigan

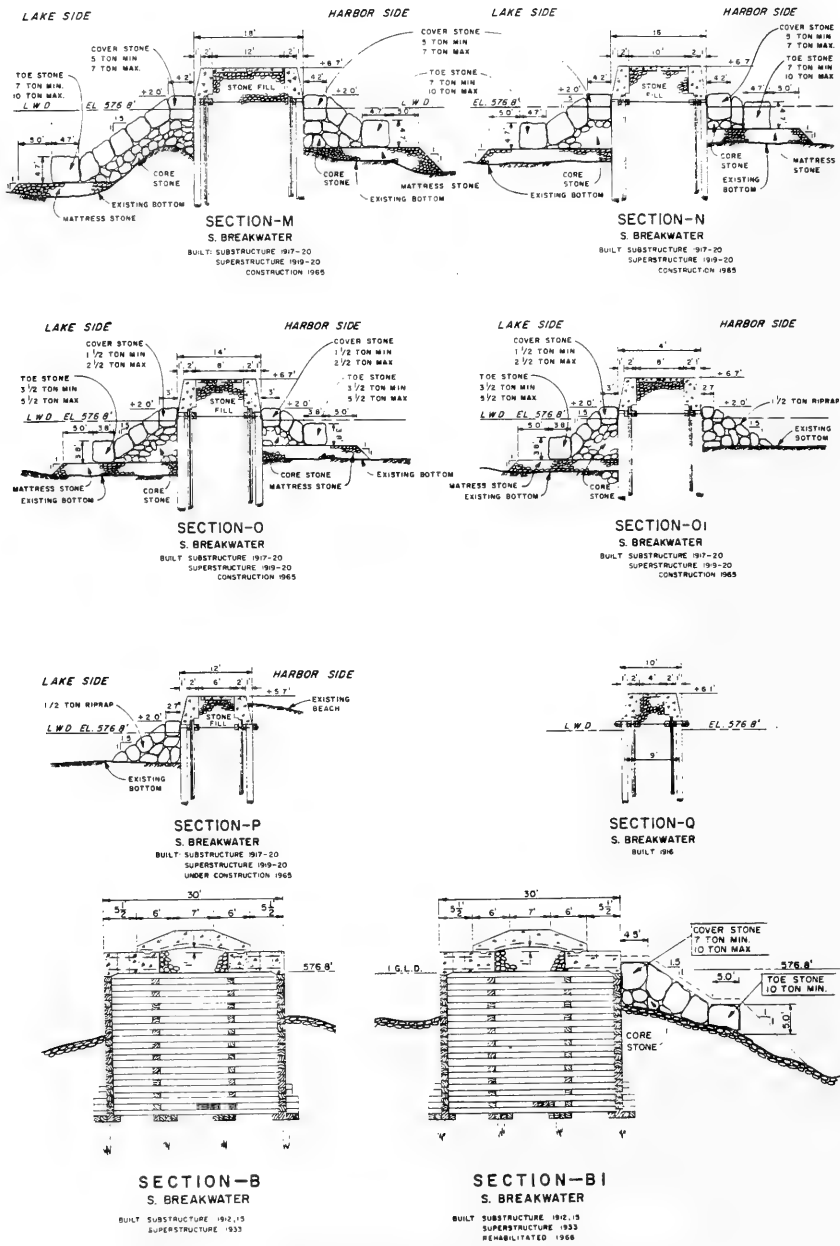


Figure 147. Typical breakwater cross sections, Manistee Harbor, Michigan



Figure 148. Aerial view of Manistee Harbor, Michigan

Table 53

Portage Lake Harbor PiersPortage Lake, Michigan

<u>Date(s)</u>	<u>Construction and Rehabilitation History</u>
1883- 1888	Construction of a 1,149-ft-long north pier and a 383-ft-long south pier (Figure 149, Sections B, C, E, and F) was completed during this time. The lakeward end of the north pier was built with 24-ft-wide, stone-filled, timber cribs (Figure 150, Section B) on a stone base. The south pier and the shoreward end of the north pier consisted of woodpilings with a stone fill.
1900- 1901	The north pier was extended lakeward by 200 ft (Figure 149, Section A), and the south pier was extended 900 ft (Figure 149, Sections A and B). The lakeward 200 ft of each pier consisted of 30-ft-wide stone-filled timber cribs (Figure 150, Section A) built on a stone base. The trunk portion of the south pier was similar except it was 24 ft in width (Figure 150, Section B).
1939- 1940	The shoreward ends of the piers (Figures 149 and 150, Sections C, E, and F) were rebuilt with woodpilings spaced from about 18 to 24 ft apart and filled with stone. Concrete and stone superstructures were constructed along the entire length of each pier (Figure 150) to a crest el of +7.0 ft lwd.
1980- 1981	Riprap stone was placed around the heads of the north and south piers (Figure 149, Section A) during this period, and stone fill was replenished at various areas along both piers. After replenishment, the concrete caps were repaired.
1985	An inspection of the site indicated the piers were, in general, in fair condition. Settlement and cracking of the superstructure and fill stone loss indicate some substructure deterioration. Replenishment with large fill stone has been recommended along with additional riprap installation. An aerial view of Portage Lake Harbor piers is shown in Figure 151.

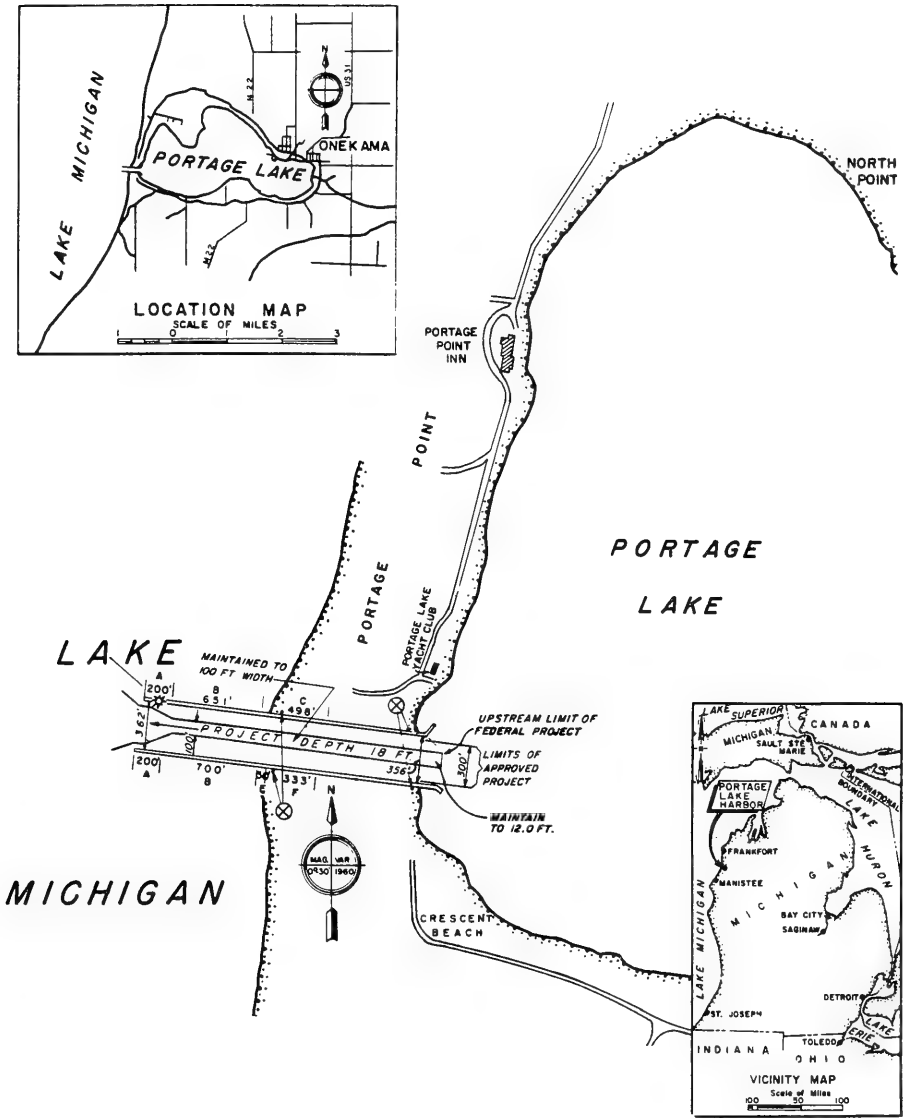
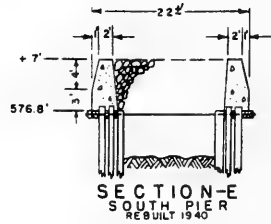
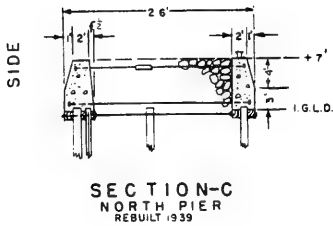
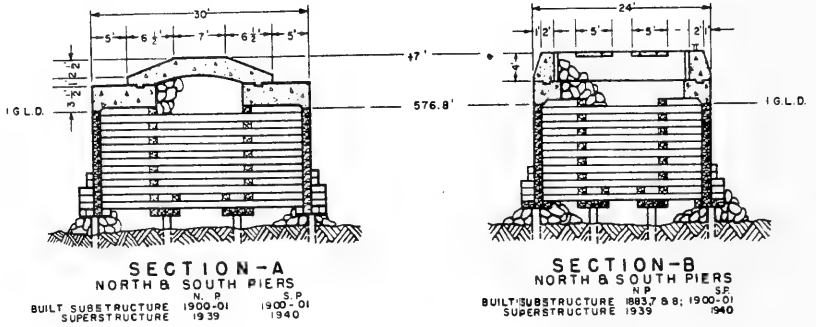


Figure 149. Portage Lake Harbor, Michigan



CHANNEL

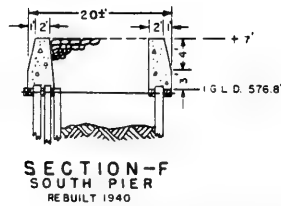


Figure 150. Typical pier cross sections, Portage Lake Harbor, Michigan



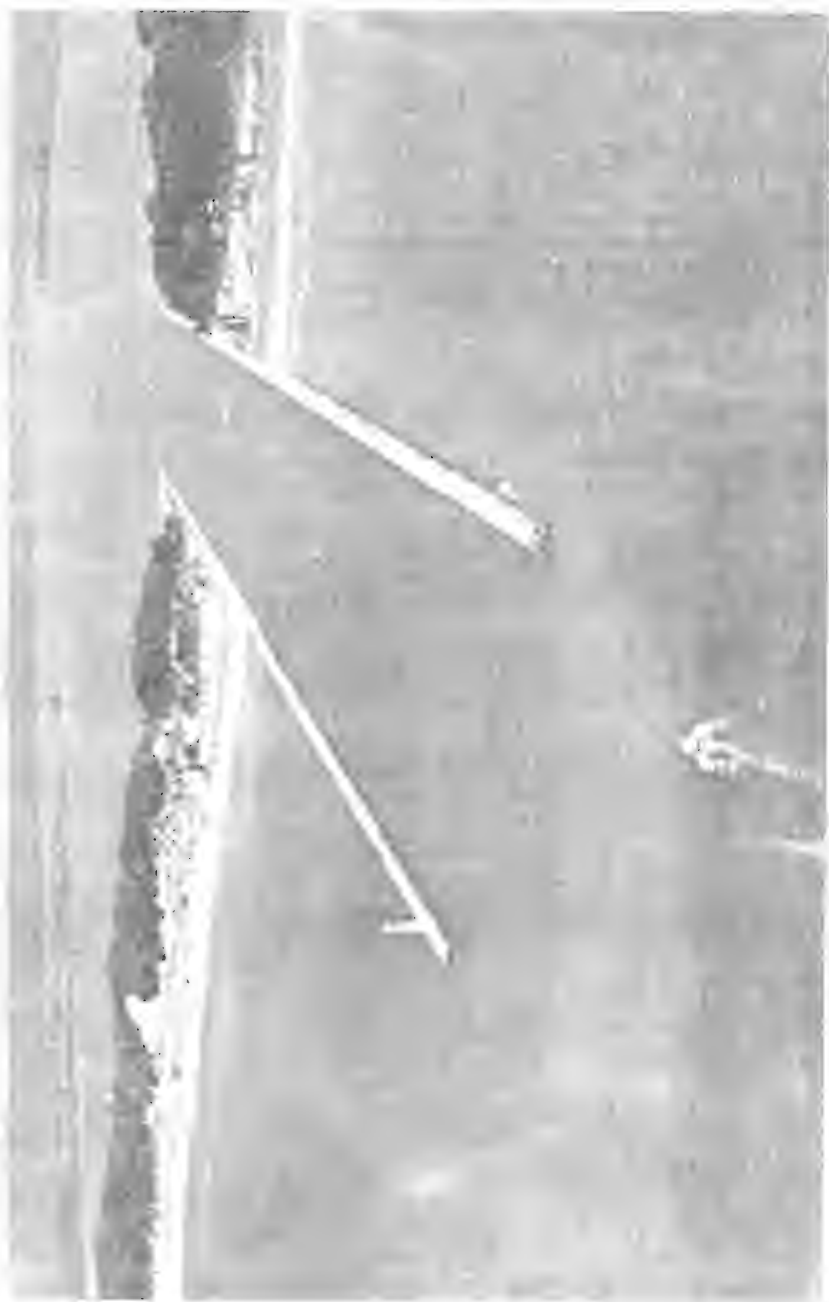


Figure 151. Aerial view of Portage Lake Harbor, Michigan

Table 54

Arcadia Harbor Piers

Arcadia, Michigan

Date(s)	Construction and Rehabilitation History
1909	Construction of a 620-ft-long north pier and a 790-ft-long south pier (Figure 152) was completed by private interests. The north pier is a stone-filled timber crib, and the south pier consists of stone-filled timber cribs and steel sheetpiling with concrete caps. The outer end of the south pier is a 20-ft semicircular steel sheet-pile cell with a concrete cap.
1971	Maintenance of the project by the Corps was authorized. Maintenance of the piers prior to this time was performed by private interests and the Michigan Department of Natural Resources.
1973	Riprap stone was placed along and into the water along 490 ft of the north pier which was in a very poor to failed condition.
1983	Fill stone was placed in the steel sheet-pile cell at the head of the south pier, and riprap stone was placed around and on top of the cell. A 35-ft breached area and a 10-ft breach near the shoreline of the south pier also were repaired with fill/core and riprap stone.
1985	An inspection of the site indicated settled and/or washed out stone in numerous areas of the north pier. Water is washing through the voids of the structure, and three areas are nearly breached. The steel sheet-pile cell at the head of the south pier is completely broken out, and most of the grout cap along the entire length of the pier is missing with stone being washed out. The condition of the piers is very poor, and immediate reconstruction/rehabilitation has been recommended.

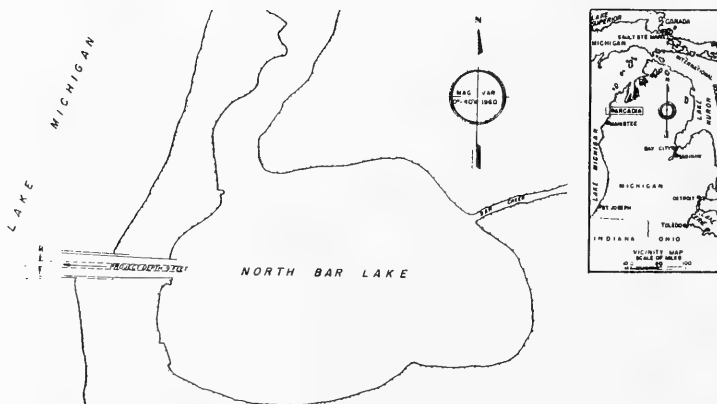


Figure 152. Arcadia Harbor, Michigan

Table 55  
Frankfort Harbor Structures  
Frankfort, Michigan

Date(s)	Construction and Rehabilitation History
1868- 1873	Construction of the south pier (Figure 153, Sections N-1, N, and O) was completed during this time frame. The lakeward end of the pier was constructed with 20-ft-wide stone-filled timber cribs (Figure 154, Sections N and N-1). The shoreward portion (Section O) was composed of woodpilings spaced about 21 ft apart and filled with stone and sand.
1870- 1879	Construction of the shoreward 603-ft length of the north pier (Figure 153, Sections L-1 and L) was completed. The pier was a 20-ft-wide stone-filled timber crib structure (Figure 154, Sections L-1 and L).
1889- 1895	A 200-ft-long extension of the north pier was completed (Figure 153, Section K). The extension consisted of a stone-filled timber crib structure that was 24 ft in width (Figure 154, Section K).
1928- 1932	Construction of the north and south breakwaters (Figure 153) was completed during this period. The lakeward portions of the structures consisted of stone-filled concrete breakwaters (Figure 156, Sections A, B, and C). The crest widths were slightly more than 7 ft with els of +7.1 ft lwd. The outer ends of the breakwaters each included 2 rectangular caissons for a distance of 54 ft. The shoreward ends of the breakwaters were woodpilings spaced from 11 to 14 ft apart (Figures 155 and 156, Sections D, E, F, G, H, I, and J). The structures were stone filled and capped with concrete and stone superstructures. The north and south breakwaters ranged from 14 to 17 ft in width and had crest els of +7.1 and +7.3 ft lwd, respectively (Figures 155 and 156).
1933- 1963	A total of 71,496 tons of riprap was placed along the sides of the lakeward ends of the north and south breakwaters (Figure 156, Sections A, B, and C).
1934	The north and south piers (Figure 153) were capped with concrete and stone superstructures (Figure 154, Sections K, L, L-1, N, N-1, and O). The piers ranged from 23 to 27 ft in width with crest els of +7.0 ft lwd.
1950	The shoreward end of the south pier (Figure 153, Section O) was reconstructed by the installation of steel sheetpiling on the channel side (Figure 154, Section O). The void between the existing structure and the new steel sheetpiling was filled with stone and capped with concrete at an el of +7.0 ft lwd.
1953	The lakeward 36 ft of the south pier (Figure 153, Section N-1) was repaired by encasing it in steel sheetpiling (Figure 154, Section N-1). The new width of the pier was 27 ft. Voids between the

(Continued)

(Sheet 1 of 3)

Table 55 (Continued)

Date(s)	Construction and Rehabilitation History
	existing structure and the steel sheetpiling were filled with stone and the area capped with concrete.
1958	Construction of a new north pier head and repair of the adjacent 200 ft of the north pier (Figure 153, Sections K-1 and K) was completed. The pier head consisted of a circular steel sheet-pile cell with a diameter of 23.75 ft. The cell was stone filled and capped with concrete to an el of +5.0 ft, and riprap was placed around its base on a 1-V:1.5-H slope. Section K was encased in steel sheetpiling (Figure 154). Voids were filled with stone, and the area between the existing pier and the new steel sheetpiling was capped with concrete at an el of +5.0 ft lwd. The new pier width was 33 ft.
1960- 1961	The shoreward portion of the north pier (Figure 153, Sections L-1 and L) was encased in steel sheetpilings (Figure 154) resulting in a new pier ranging from 29.75 ft (Section L) to 33 ft (Section L-1) in width. The voids between the new steel sheetpiling and the existing piers was filled with stone and capped with concrete (Figure 154).
1966	The shoreward portion of the south breakwater (Figure 153, Sections F, G, H, and I) was rehabilitated. Rehabilitation consisted of the placement of stone along the structures (Figure 155) on slopes of 1V:1.5H. Cover stone ranged from 9 (min) to 12 tons (max) along Section F, 6 (min) to 8 tons (max) along Section G, and 3.5 (min) to 5.5 tons (max) along Section H (Figure 155) on both sides of the breakwater. Riprap (1 ton) cover stone was installed on the lakeside only of Section I.
1977	Portions of the north breakwater (Figure 153, Sections D and E) were replenished with fill stone, and the structure was grouted over with concrete.
1981	Riprap stone was placed around the heads of both the north and south breakwaters (Figure 153, Section A). The lakeward end of the south pier (Figure 153, Sections N and N-1) was repaired by encasing it in steel sheetpiling (Figure 154, Sections N and N-1). Voids between the existing pier and new steel sheetpiling were filled with stone which was covered with a concrete cap at an el of +7.0 ft lwd. Section N was 30 ft wide, and Section N-1 was 32 ft wide (Figure 154).
1982	The landward portion of the south pier (Figures 153 and 154, Section O) was repaired, and riprap was placed on the channel side of the pier with 1-V:2.5-H side slopes. Fill stone also was replenished in the north pierhead cell (Figure 153, Section K-1).

(Continued)

(Sheet 2 of 3)

Table 55 (Concluded)

Date(s)	Construction and Rehabilitation History
1984	Riprap stone was placed along the lakeward end of the south breakwater (Figure 153, Section A).
1985	An inspection of the structures indicated that the breakwaters were, generally, in fair condition. Their superstructures revealed cracks, settlement, and misalignment in areas, which indicate some substructure deterioration. Riprap was also needed in areas. The piers were considered in good condition during the inspection. An aerial view of the Frankfort Harbor structure is shown in Figure 157.

(Sheet 3 of 3)

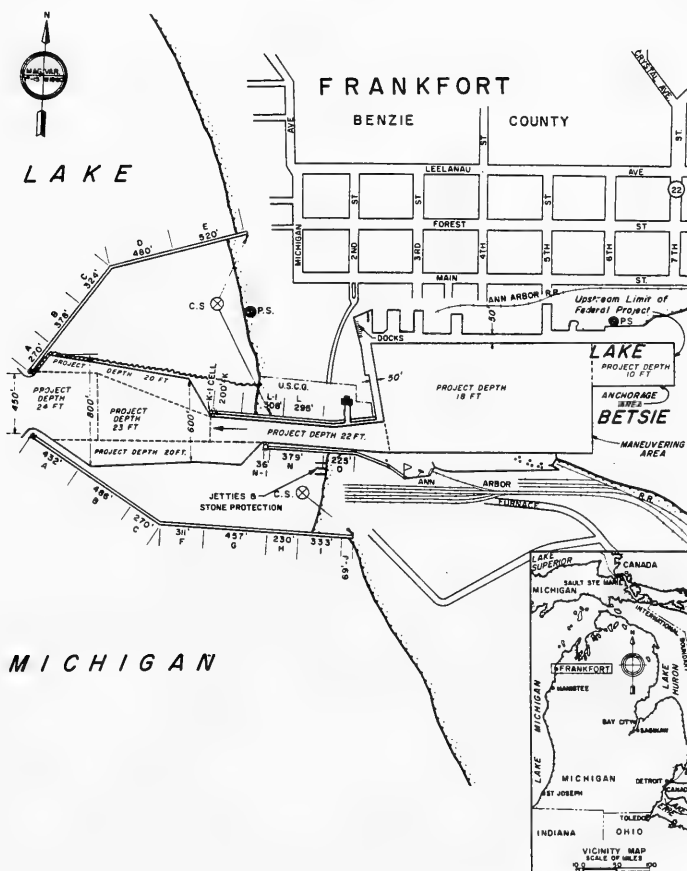


Figure 153. Frankfort Harbor, Michigan

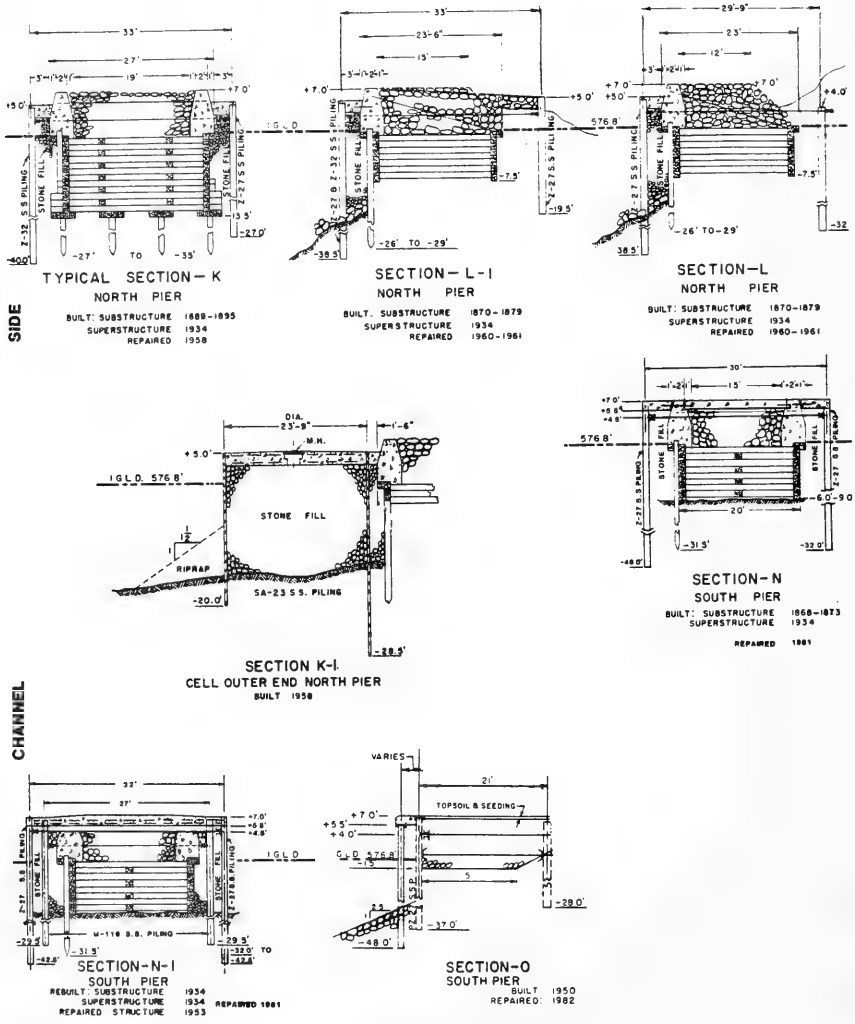
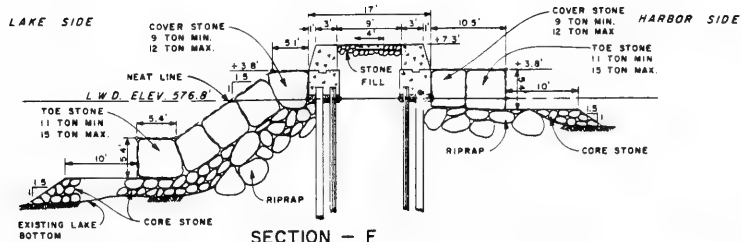
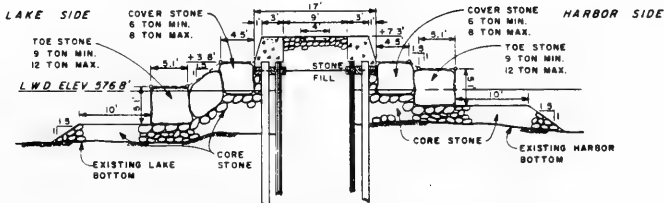


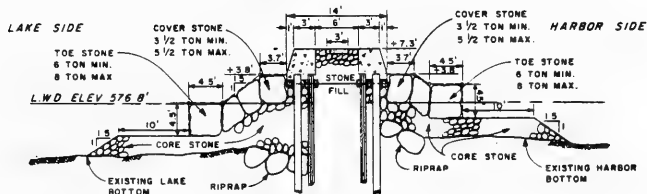
Figure 154. Typical pier cross sections, Frankfort Harbor, Michigan



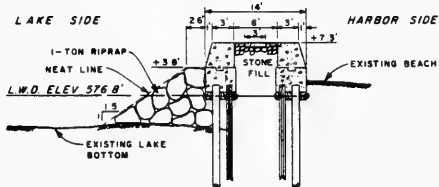
**SECTION - F**  
**S. BREAKWATER**  
 BUILT: 1928-31  
 REHABILITATED 1966



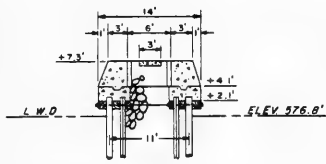
**SECTION - G**  
**S. BREAKWATER**  
 BUILT: 1928-31  
 REHABILITATED 1966



**SECTION - H**  
**S. BREAKWATER**  
 BUILT: 1928-31  
 REHABILITATED 1966

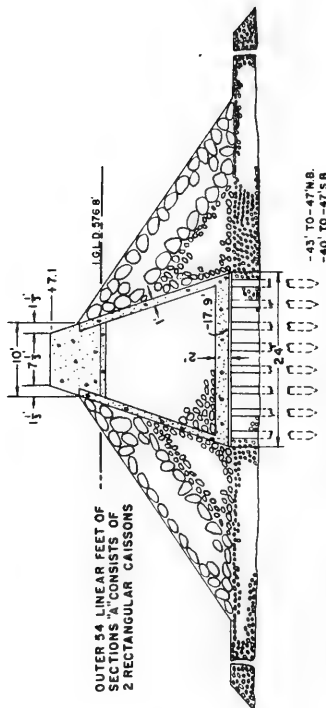


**SECTION - I**  
**S. BREAKWATER**  
 BUILT: 1928-31  
 REHABILITATED 1966



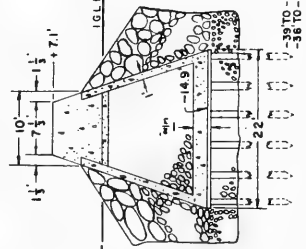
**SECTION - J**  
**S. BREAKWATER**  
 BUILT: 1928-31

Figure 155. Typical breakwater cross sections, Frankfort Harbor, Michigan

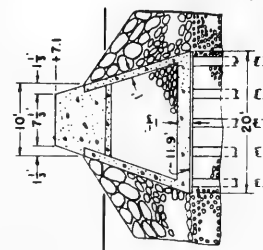


-43 TO -47 M.B.  
-40 TO -47 S.B.

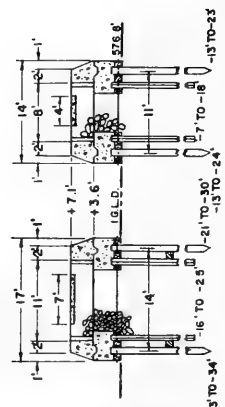
**SECTION - A**  
NORTH AND SOUTH BREAKWATER  
BUILT, SUBSTRUCTURE 1932  
SUPERSTRUCTURE 1932  
1928-31  
1928-31



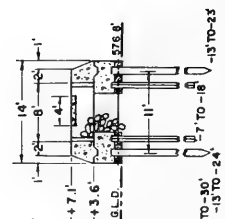
**SECTION - B**  
N & S BREAKWATER  
BUILT, SUBSTRUCTURE 1932  
SUPERSTRUCTURE 1932  
1928-31  
1928-31



**SECTION - C**  
N & S BREAKWATER  
BUILT, SUBSTRUCTURE 1932  
SUPERSTRUCTURE 1932  
1928-31  
1928-31



**SECTION - D**  
N. BREAKWATER  
BUILT 1932



**SECTION - E**  
N. BREAKWATER  
BUILT 1932

SIDE HARBOR

Figure 156. Typical breakwater cross sections, Frankfort Harbor, Michigan



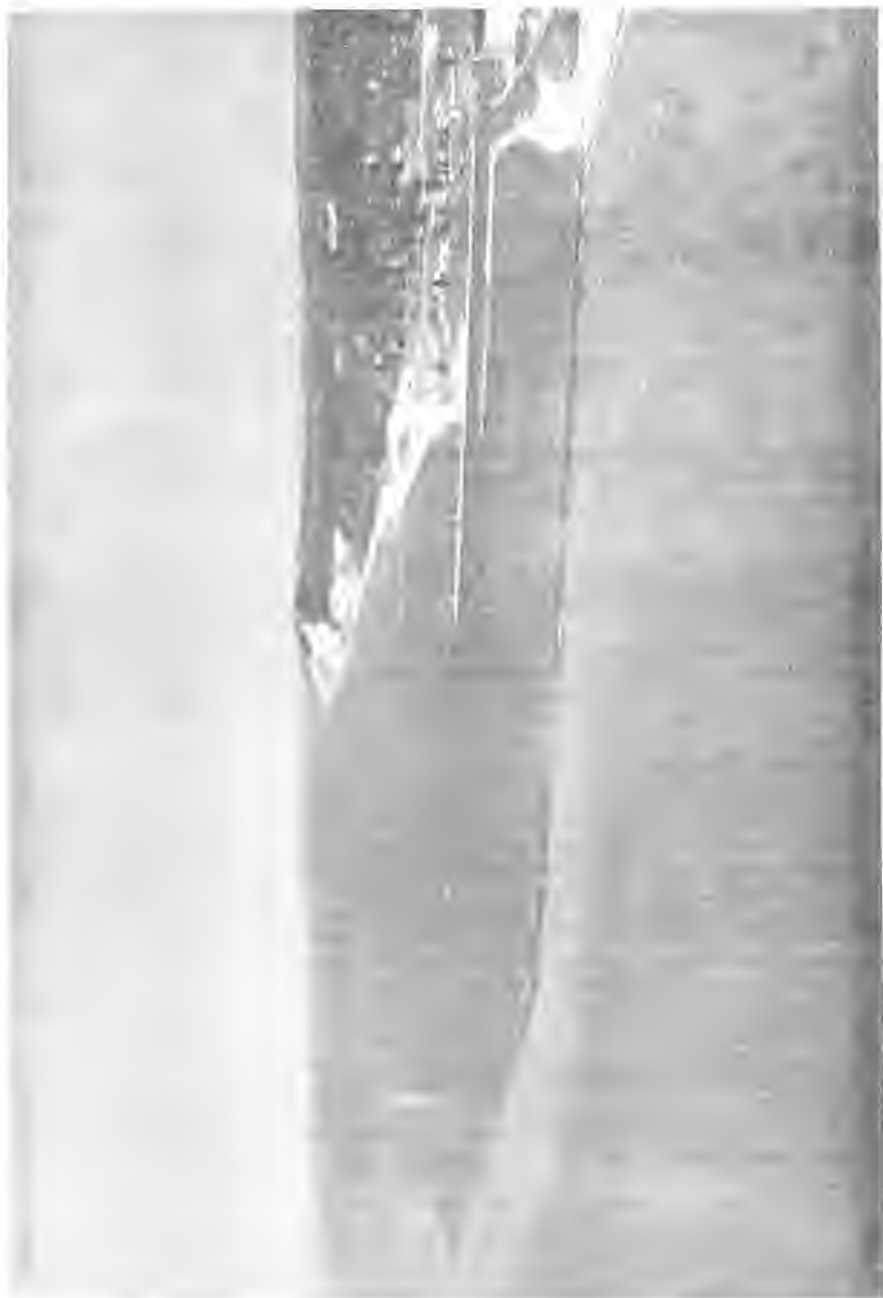


Figure 157. Aerial view of Frankfort Harbor, Michigan

Table 56  
Leland Harbor Structures  
Leland, Michigan

Date(s)	Construction and Rehabilitation History
1936	Construction of a 440-ft-long south pier (Figure 158, Sections B and C) was completed. The pier consisted of woodpilings spaced 11 ft apart and filled with stone (Figure 159, Sections B and C).
1952	The lakeward 33 ft of the south pier (Figure 158, Section B) was encased in steel sheetpiling. The voids were filled with stone, and the structure was capped with stone (Figure 159, Section B). The width of this portion of the south pier was 15.25 ft, and the crest el was +8 ft lwd.
1966	The lakeward 33 ft of the south pier (Figure 158, Section B) was rehabilitated. Riprap was placed on each side of the pier. It was -5 ft at its crest and had 1-V:1.5-H side slopes (Figure 159, Section B).
1968	A 407-ft-long portion of the south pier (Figure 158, Section C) was rehabilitated by the placement of stone along both sides and across the top of the pier (Figure 159, Section C). The new rubble-mound pier had an 8-ft crest width and a +8.0-ft lwd crest el. Cover stone ranged from 1 (min) to 2 tons (max), and side slopes were 1V:1.5H. A 35-ft-long extension of the south pier (Figure 158, Section A) involved the construction of two steel sheet-pile cells with diameters of 17.5 ft each. The cells were filled with coarse aggregate and capped with 500-lb (min) stone. The crest el of the cells was +8.0 ft lwd, and riprap was installed around the lakeward cell. A 1,200-ft-long offshore rubble-mound breakwater (Figure 158) also was constructed. The breakwater had an 8-ft crest width, 1-V:1.75-H side slopes on the lakeside, and 1-V:1.5-H side slopes on the harbor side (Figure 159). The 300-ft-long north shore arm had a crest el of +8.0 ft lwd (Figure 158, Section II), and the remaining 900 ft of the breakwater (Figure 158, Section I) had a crest el of +10.0 ft lwd. Cover stone of the breakwater ranged from 5 (min) to 7 tons (max), and core stone ranged from 500 to 1,000 lb.
1983	A site inspection of the harbor structures revealed them to be in fair to good condition. Settlement of cover stone and a portion of the north shore arm of the breakwater (Figure 158, Section II) was observed and has subsequently been repaired by the placement of additional stone. Stone settlement of portions of the entire south pier were observed and scheduled for replenishment.
1985	The structures are currently considered to be in good condition.

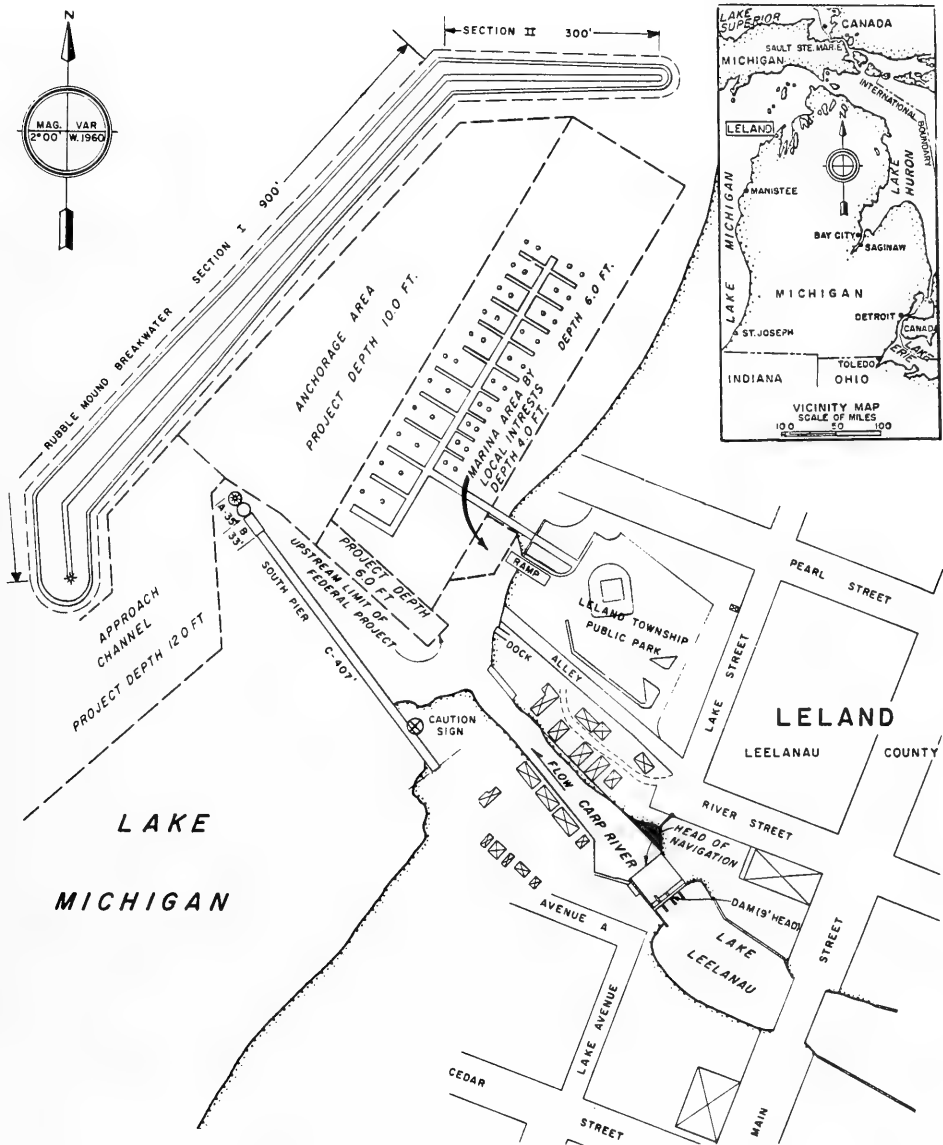
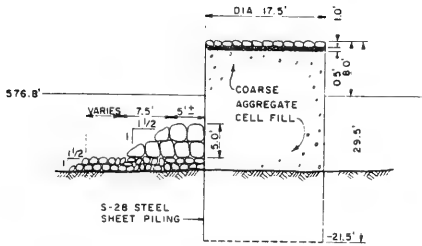
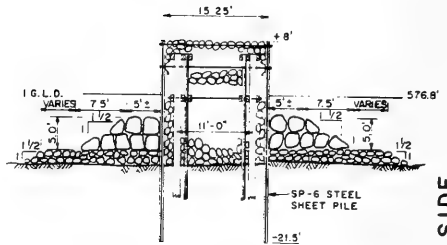


Figure 158. Leland Harbor, Michigan

SIDE

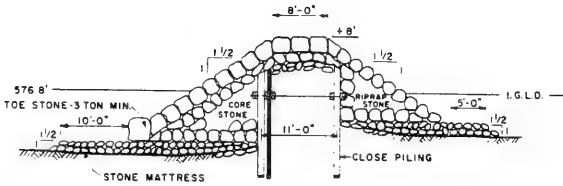


SECTION-A  
CONSTRUCTED: 1968



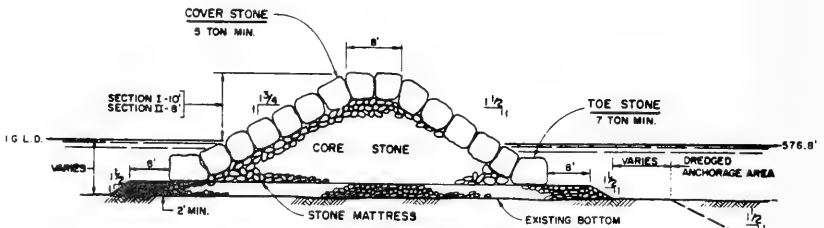
SECTION-B  
BUILT: 1936  
REPAIRED: 1952  
REHABILITATED: 1966

SIDE



SECTION-C  
BUILT: SUBSTRUCTURE: 1936  
CONSTRUCTED: 1968

LAKE



TYPICAL CROSS SECTION-RUBBLE MOUND BREAKWATER  
CONSTRUCTED: 1968

HARBOR

Figure 159. Typical structure cross sections, Leland Harbor, Michigan

Table 57

Greilickville (formerly Traverse City) Harbor Breakwaters  
Traverse City, Michigan

<u>Date(s)</u>	<u>Construction and Rehabilitation History</u>
1950	Construction of a 1,217-ft-long steel sheet-pile breakwater (Figures 160 and 161, Sections A and B) was completed. The crest el of the structure was +7.0 ft lwd.
1951	A 35.8-ft-diameter steel sheet-pile cell was constructed at the head of the breakwater (Figures 160 and 161, Section B-B). The cell was stone filled and capped with concrete at an el of +7.0 ft lwd.
1966	Construction of east and west rubble-mound breakwaters (Figure 160) was completed. Steel sheet-pile cells were installed on the channel ends of the breakwaters (Figure 160). The cells were 19.1 ft in diameter and had a crest el of +7.0 ft lwd (Figure 161). They were stone filled and capped with concrete. The east and west breakwaters had crest els of +8.0 ft lwd and crest widths of 8 ft. Cover stone ranged from 1 to 2 tons, and the breakwaters had 1-V:2-H side slopes (Figure 161).
1976	Stone was placed into a washed out area of the east end of the east breakwater (Figure 160).
1979	Stone was placed along both sides of the steel sheet-pile breakwater (Figure 160, Sections A and B) to reduce scouring and maintain structure stability.
1985	A site inspection of the breakwaters indicated that the rubble-mound east and west breakwaters were deteriorating slightly, with stones cracking and breaking into smaller pieces as a result of the low-grade limestone used in initial construction. Rehabilitation with sounder and slightly larger cover stones has been recommended. The breakwaters, however, were considered to be in good stable condition. An aerial photo of Greilickville Harbor breakwaters is shown in Figure 162.
1986	Traverse City Harbor was renamed "Greilickville Harbor," on 17 October 1986, in the 99th Congress, 2nd Session, Title XIII, Section 1304.



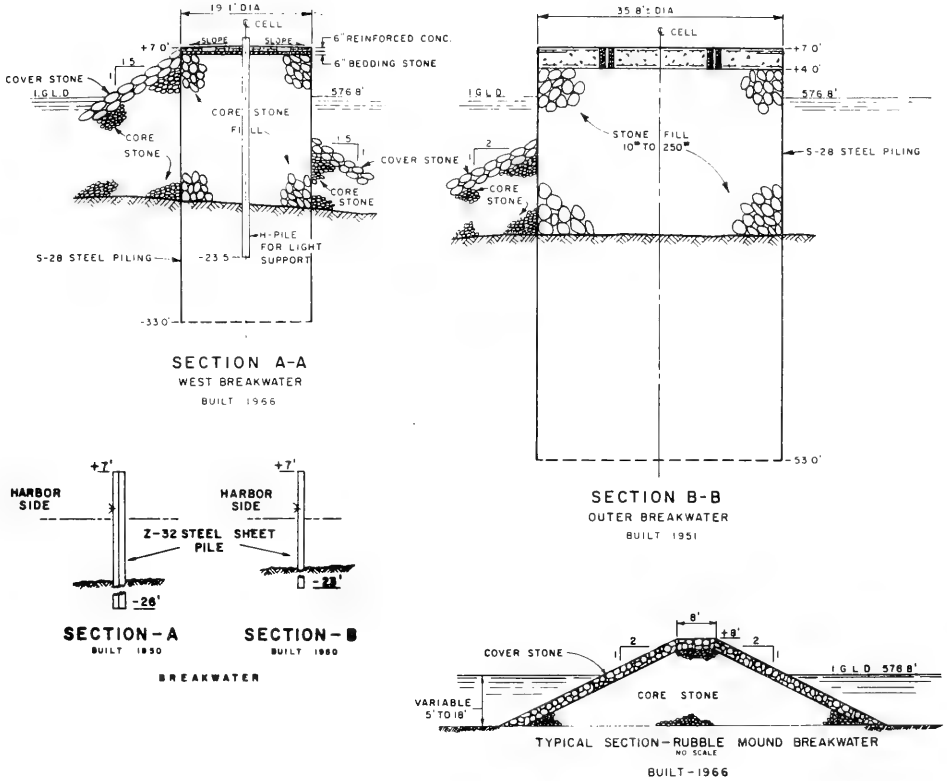


Figure 161. Typical structure cross sections, Greilickville Harbor, Michigan

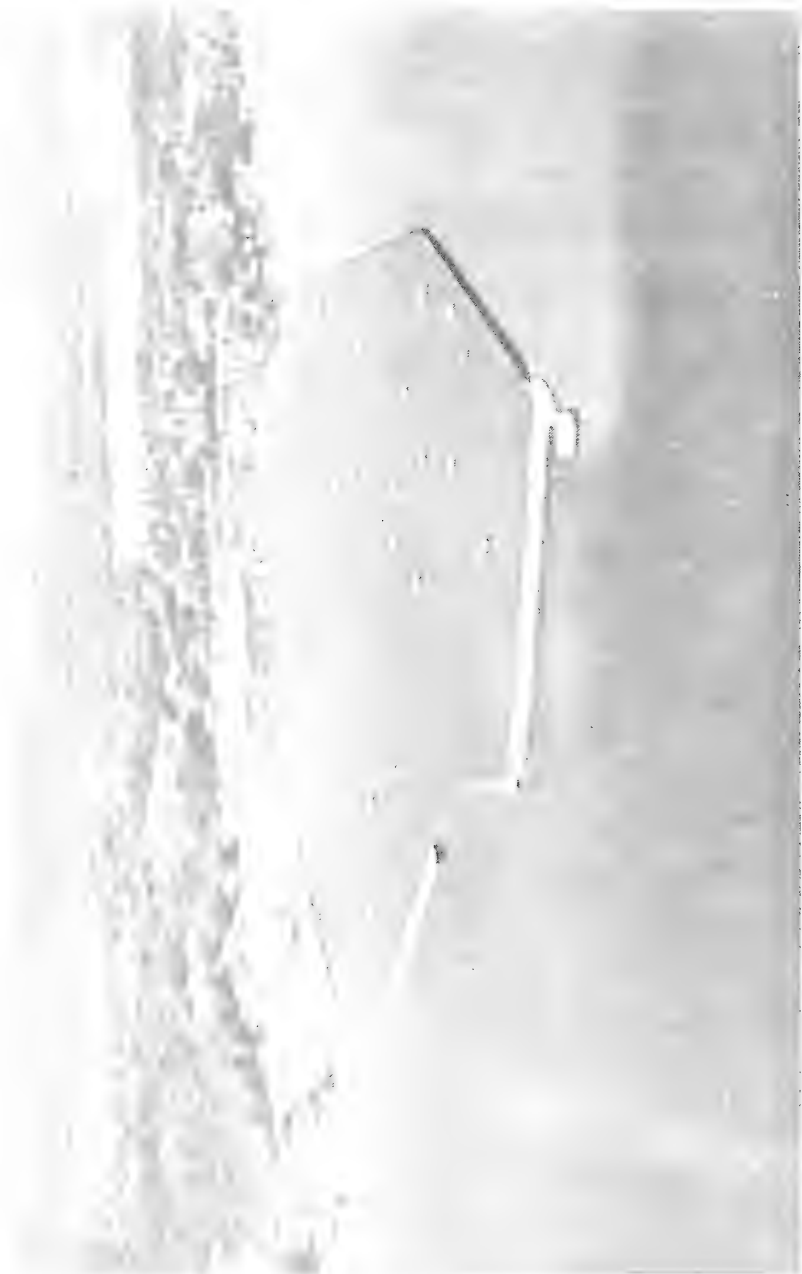


Figure 162. Aerial view of Greilickville Harbor, Michigan



Table 58

Charlevoix Harbor PiersCharlevoix, Michigan

Date(s)	Construction and Rehabilitation History
1872	Construction of a north pier (Figure 163, Section B) was completed. The structure was a 20-ft-wide stone-filled timber crib.
1879- 1880	Construction of the lakeward portions of the north and south piers (Figure 163, Sections A and A-1) was completed. The piers consisted of stone-filled timber crib structures (Figure 164, Sections A and A-1) that were 20 ft in width.
1882	Construction of a shoreward portion of the south pier (Figure 163, Section F) was completed. The pier consisted of woodpilings driven approximately 20 ft apart (Figure 164, Section F) and filled with stone.
1897	Rubble was placed along the lakeside and over the shoreward portion of the north pier (Figure 163, Section B). The crest width of the rubble structure (Figure 164, Section B) was 10 ft, and it had an el of +8.1 ft lwd. Side slopes were 1V:2H, and the cover stone used was 1,000 lb (min).
1930	The shoreward portion of the south pier (Figure 163, Section F) was repaired and capped with a concrete and stone superstructure (Figure 164, Section F). The crest el of the pier was +7.1 ft lwd.
1942	The lakeward portions of the north and south piers (Figure 163, Sections A and A-1) were capped with concrete and stone superstructures (Figure 164, Sections A and A-1) with crest els of +7.0 ft lwd.
1966	The lakeward portion of the existing north pier (Figure 163, Section A-1) was repaired by encasing it between steel sheetpiling spaced 33 ft apart (Figure 164, Section A-1). The voids between the steel sheetpiling and the existing timber crib were filled with stone and capped with concrete to an el of +6.75 ft lwd. A 35-ft-diameter steel sheet-pile cell was constructed at the head of the north pier (Figures 163 and 164, Section A-2). The pier head was filled with stone and capped with concrete at an el of +7 ft lwd. Steel sheet-piles were also installed on each side of the shoreward portion of the south pier (Figures 163 and 164, Section F). On the channel side the void was filled with stone, and the crest was grouted at an el of +6.5 ft lwd.
1971	Replenishment of fill stone was performed on the lakeward portion of the south pier (Figure 163, Section A).
1981	Portions of the north (Figure 163, Sections A and B) and south (Figure 163, Section A) piers were rehabilitated. The existing timber

(Continued)

Table 58 (Concluded)

Date(s) Construction and Rehabilitation History

cribs were encased in steel sheetpiling (Figure 164, Section A). The voids between the steel sheetpiling and the cribs were filled with stone and capped with concrete at an el of +6.75 ft lwd. The rubble portion of the north pier (Figure 164, Section B) was repaired, and a concrete cap was included which had an el of +8.5 ft lwd.

1985 An inspection of the piers revealed them to be in fair condition. Settlement and loss of fill stone are evidenced in the piers, and some of the structures are cracked and tilting. Replenishment of fill with larger stone, and placement of riprap along the piers have been recommended. An aerial view of the Charlevoix Harbor piers is shown in Figure 165.

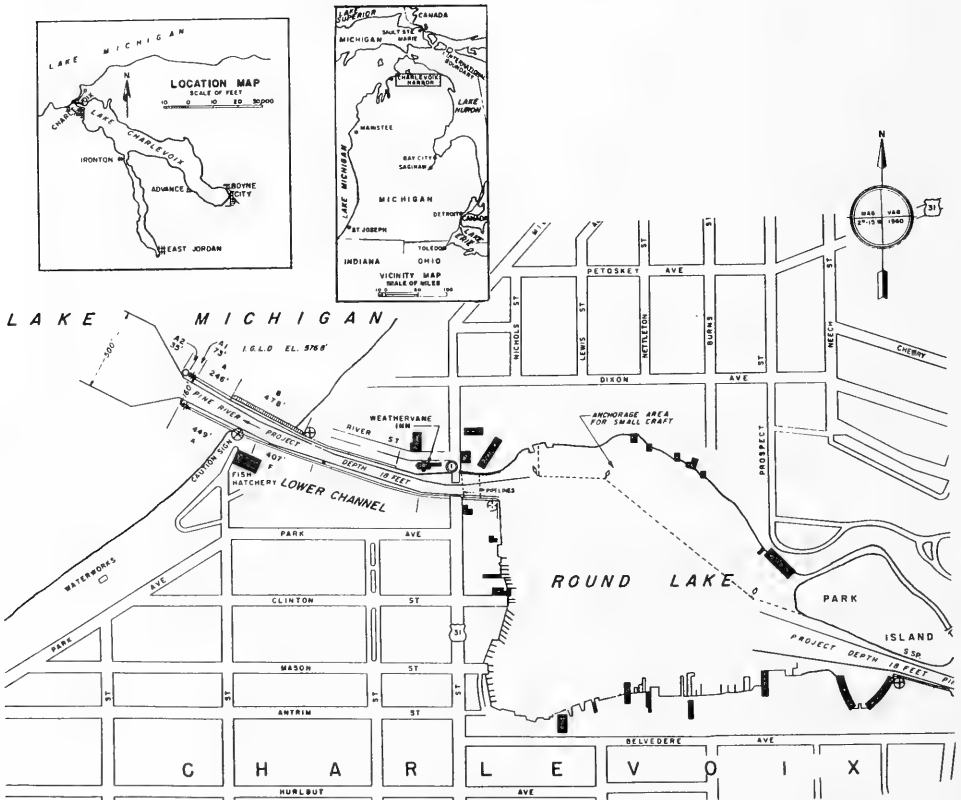


Figure 163. Charlevoix Harbor, Michigan





Figure 165. Aerial view of Charlevoix Harbor, Michigan

Table 59  
Petoskey Harbor Breakwater  
Petoskey, Michigan

Date(s)	Construction and Rehabilitation History
1895- 1896	Construction of a 600-ft-long portion of the breakwater (Figure 166, Sections B and C) was completed. This breakwater consisted of stone-filled timber cribs built on a stone base (Figure 167, Sections B and C). Part of the breakwater was 26 ft wide (Section B), and the remaining portion (Section C) was 28 ft wide.
1897	Construction of the 355-ft-long shoreward portion of the breakwater (Figure 166, Sections D and E) was completed. This portion of the breakwater was rubble mound with a 10-ft crest width and a +7.0 ft lwd crest el (Figure 167, Sections D and E). A concrete walkway was also installed on its crest.
1905- 1907	Construction of the lakeward end of the breakwater (Figure 166, Section A) was completed. This portion of the breakwater was a 30-ft-wide stone-filled timber crib built on a stone base (Figure 167, Section A).
1930	The lakeward 895 ft of the breakwater (Figure 166, Sections A, B, and C) was capped with a stone and concrete superstructure. The crest el of the breakwater was +7.0 ft lwd (Figure 167, Sections A, B, and C).
1949	The rubble-mound portions of the breakwater (Figure 166, Sections D and E) were rehabilitated.
1970	The rubble-mound sections of the breakwater (Figure 166, Sections D and E) were rebuilt (including the concrete walkway).
1973	Riprap stone (1 to 6 tons) was placed along both sides of the rubble-mound portion of the breakwater (Figure 166, Sections D and E).
1977	Riprap stone was placed in areas along both sides of the timber crib breakwater (Figure 166, Sections A, B, and C).
1978	Replenishment of fill stone was performed in the timber cribs (Sections A, B, and C), and additional riprap was placed along areas of the timber crib breakwater where stone was not placed in 1977. Riprap was also placed along the rubble-mound breakwater (Sections D and E) where washouts and voids existed.
1985	A site inspection of the breakwater indicated superstructure tilt, settlement, cracking, and loss of fill stone along the timber-crib portion of the structure (Sections A, B, and C) which suggests substructure deterioration. The rubble-mound portion of the breakwater

(Continued)

Table 59 (Concluded)

Date(s)	Construction and Rehabilitation History
	<p>(Sections D and E) had stone voids and washouts in areas, and the concrete walkway was undermined. New stone (2,750 tons) was placed at the base of the structure, and about 300 tons of stone was recovered and replaced at the harbor by hired labor. The structure is considered to be in fair condition, and rehabilitation has been recommended. An aerial view of the Petoskey Harbor breakwater is shown in Figure 168.</p>

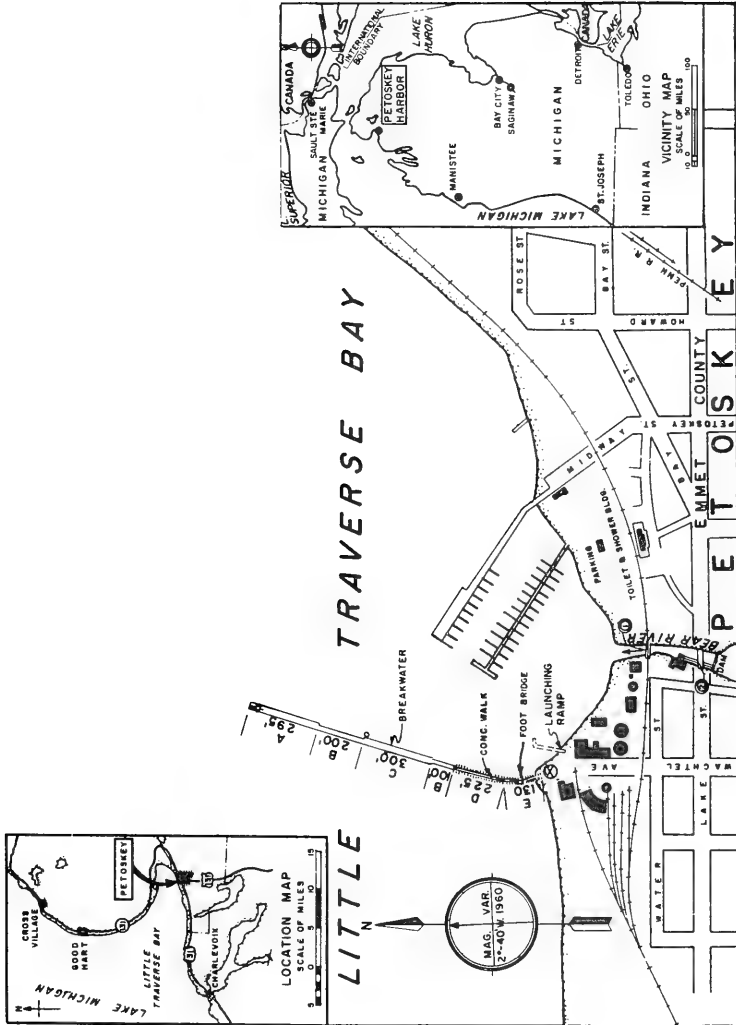


Figure 166. Petoskey Harbor, Michigan





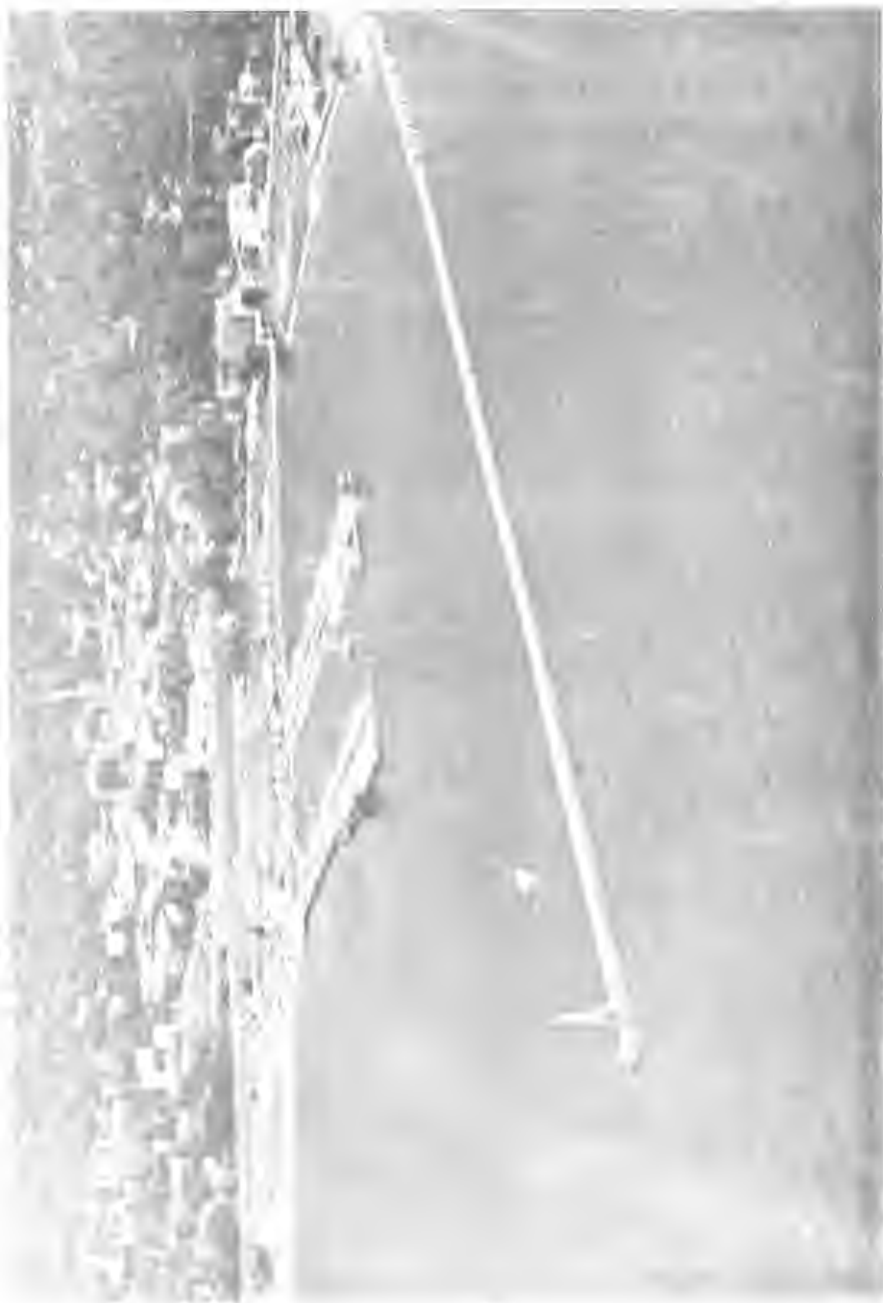


Figure 168. Aerial view of Petoskey Harbor, Michigan

Table 60

Detour Harbor Breakwater  
Detour Village, Michigan

Date(s)	Construction and Rehabilitation History
1982	Construction of a 1,310-ft-long rubble-mound breakwater (Figure 169) was completed for a cost of about \$2,000,000. The crest of the breakwater was installed at an el of +7.8 ft lwd. It was 11 ft wide and included a concrete walkway. Cover stone ranged from 950 to 1,800 lb and was placed on 1-V:1.5-H side slopes.
1986	The present condition of the breakwater is considered good.

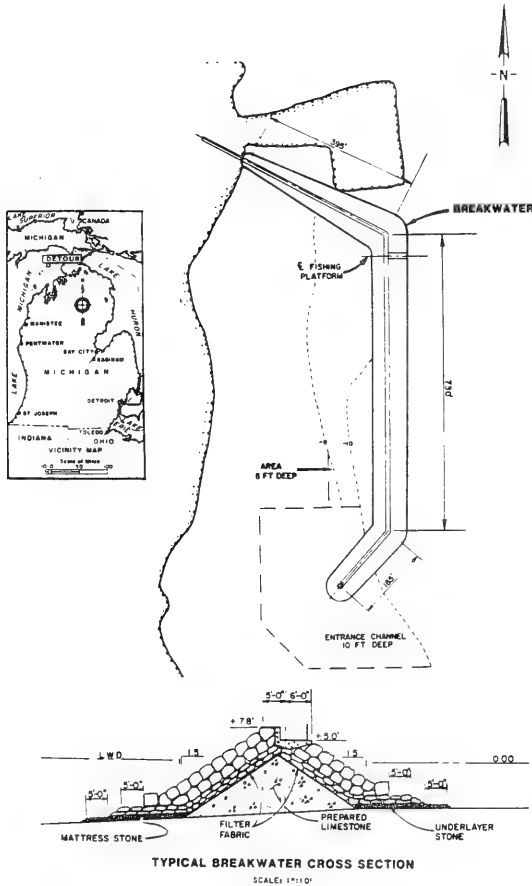


Figure 169. Detour Harbor, Michigan

Table 61

Mackinac Island Harbor BreakwatersMackinac Island, Michigan

<u>Date(s)</u>	<u>Construction and Rehabilitation History</u>
1914	Construction of a 410-ft-long east breakwater and a 950-ft-long west breakwater (Figure 170) was completed. The breakwaters were rubble mound with a crest width of 10 ft and an el of +6.0 ft lwd. Side slopes were 1V:1.5H.
1967	A 500-ft-long lakeward rubble-mound extension to the east breakwater (Figure 170) was completed. The extension had a crest el of +8.5 ft lwd and a crest width of 8 ft. Stone was placed on 1-V:1.5-H side slopes, and cover stone ranged from 3 to 5 tons at the breakwater head and from 2.5 to 4.5 tons on its trunk.
1986	The stone in the breakwaters has been replenished and replaced periodically during its lifetime, and the structures are presently in fair condition. An aerial view of the Mackinac Island Harbor breakwaters is shown in Figure 171.

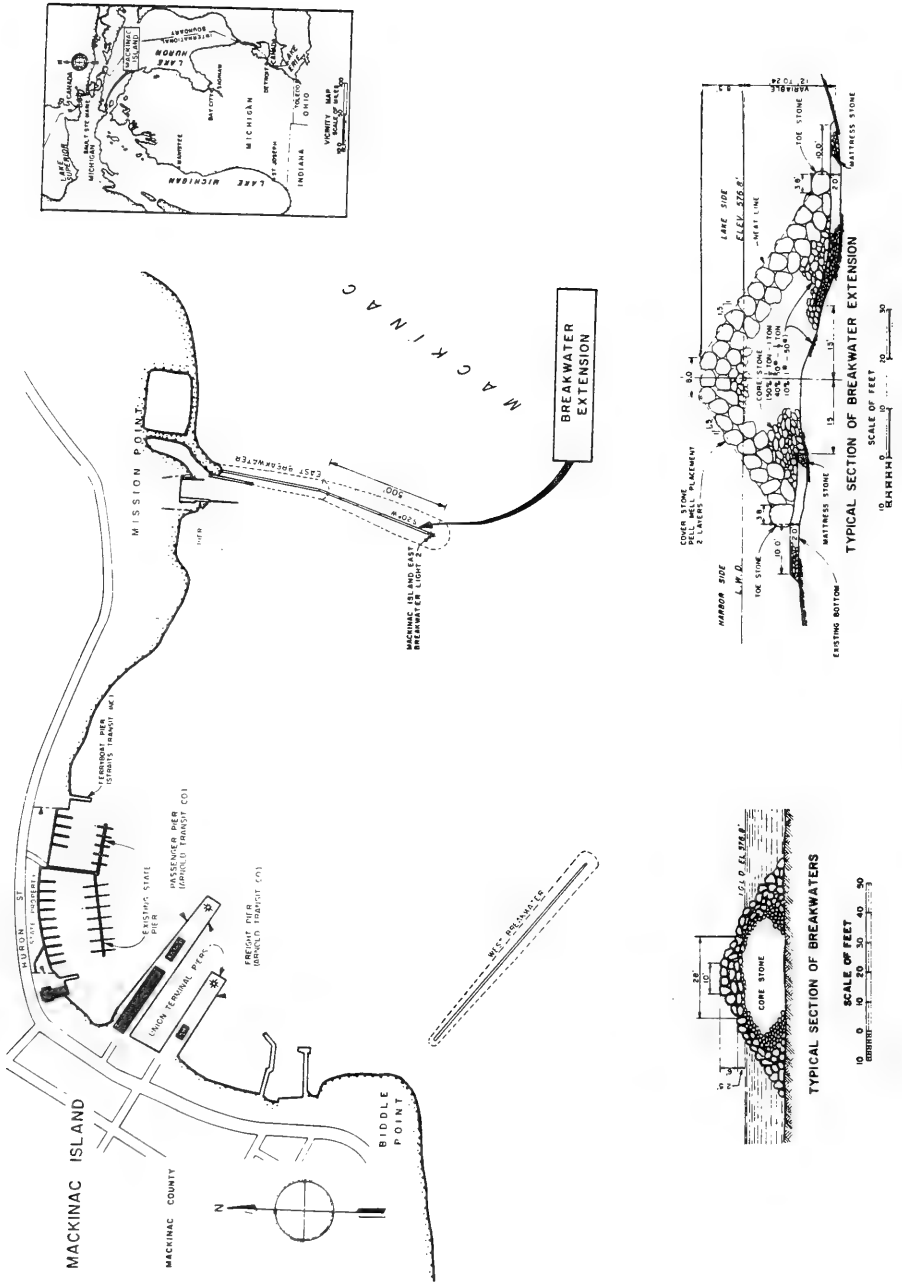


Figure 170. Mackinac Island Harbor, Michigan



Figure 171. Aerial view of Mackinac Island Harbor, Michigan

Table 62

Mackinaw City Harbor Breakwaters  
Mackinaw City, Michigan

Date(s)	Construction and Rehabilitation History
1955	Construction of a 600-ft-long causeway, which serves as a breakwater, was completed by local interests (Figure 172). The structure was built of rock and concrete. The harbor side of the structure was lined with vertical sheetpiling, and the lakeward side was constructed with rubble-mound materials with side slopes of about 1V:1H (the natural angle of repose).
1967	Construction of a 430-ft-long rubble-mound breakwater (Figure 172) was completed. The breakwater had a crest el of +8.8 ft lwd with a width of 8 ft. One- to two-ton cover stone was used in construction along with side slopes of 1V:1.5H (Section B-B). The outer 200 ft of the existing breakwater was authorized for federal maintenance.
1986	The breakwaters presently are considered to be in good condition. An aerial photo of the Mackinaw City Harbor breakwaters is shown in Figure 173.

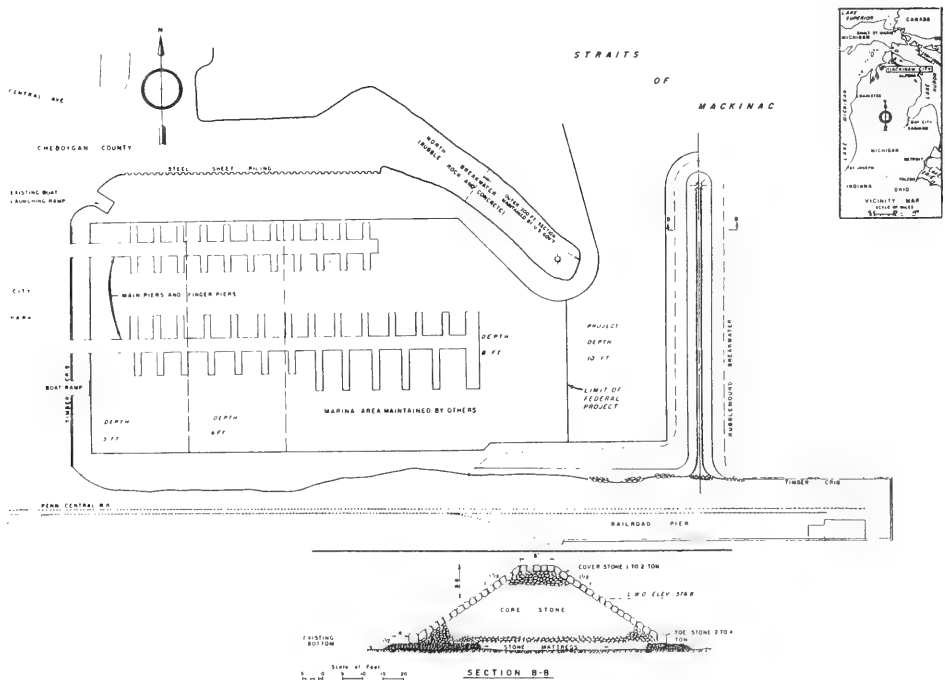


Figure 172. Mackinaw City Harbor, Michigan

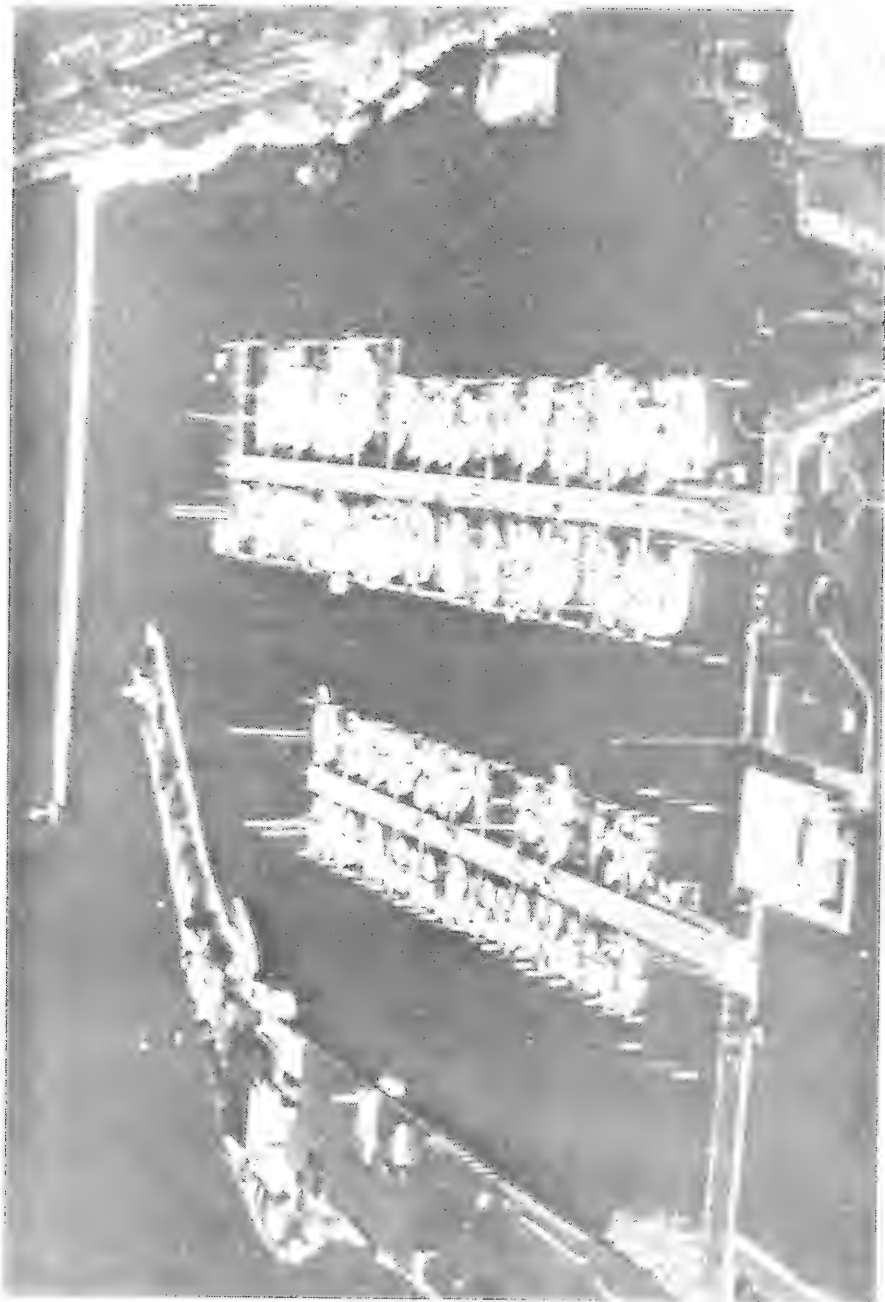


Figure 173. Aerial view of Mackinaw City Harbor, Michigan

Table 63

Cheboygan Harbor Breakwater

Cheboygan, Michigan

Date(s)	Construction and Rehabilitation History
1968	Construction of a 775-ft-long rubble-mound breakwater (Figure 174) was completed. The breakwater was constructed with a crest el of +6.0 ft lwd and a crest width of 8 ft. Cover stone was 2 tons (min), toe stone was 4 tons (min), and side slopes of the structure were 1V:1.5H (Figure 174).
1982	Minor repairs to the existing stone breakwater and construction of a concrete walkway on the crest of the structure were completed.
1986	The breakwater is presently considered to be in good condition. An aerial photograph of the Cheboygan Harbor breakwater is shown in Figure 175.

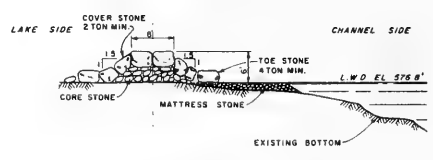
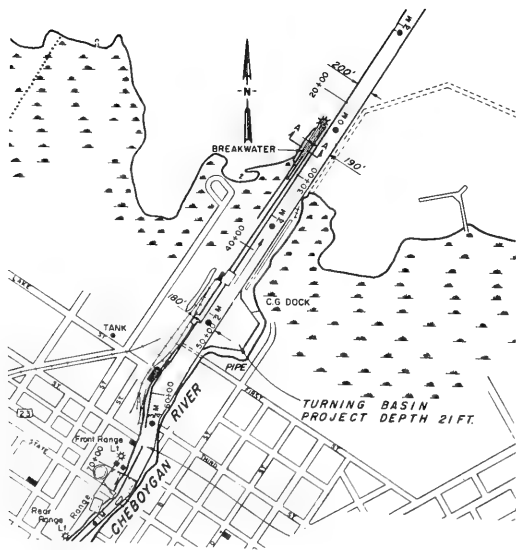


Figure 174. Cheboygan Harbor, Michigan





Figure 175. Aerial view of Cheboygan Harbor, Michigan

Table 64

Hammond Bay Breakwaters

Hammond Bay, Michigan

Date(s)	Construction and Rehabilitation History
1965	Construction of a 460-ft-long west breakwater and a 1,445-ft-long east breakwater were completed (Figure 176). The breakwaters were rubble-mound structures with crest widths of 8.0 ft (Figure 176). The crest el of the west breakwater (Section A) and the shoreward arm of the east breakwater (Section D) was +8 ft lwd, while the remaining portions of the east breakwater (Sections B and C) had a crest el of +10 ft lwd. Cover stone for Sections A and D was 1 ton (min), and for Sections B and C cover stone of 3.5 tons (min) was used in construction. Toe stone for Sections A and D was 3 tons and for Sections B and C it was 3.5 tons. Side slopes of 1V:1.5H were also used.
1982	A total of 210 tons of 3- to 5-ton cover stone was added to supplement the existing cover stone. The cost of these repairs was about \$133,000.
1984	An inspection of the breakwaters noted some winter storm damage to the east breakwater. Some cover stone and core stone was missing over about a 70-ft-long area. The west breakwater was in good condition.
1986	The breakwaters presently are considered in fair condition. An aerial view of the Hammond Bay breakwaters is shown in Figure 177.

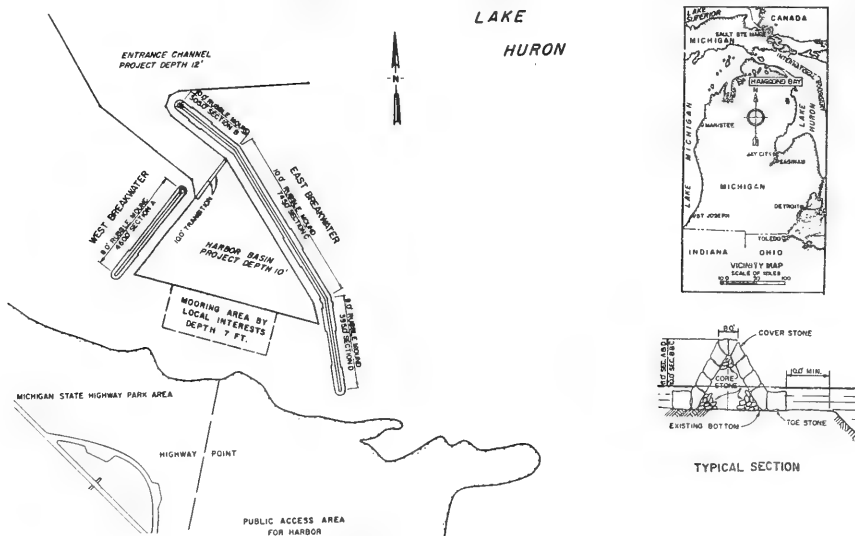


Figure 176. Hammond Bay Harbor, Michigan



Figure 177. Aerial view of Hammond Bay Harbor, Michigan

Table 65

Alpena Harbor Breakwater  
Alpena Harbor, Michigan

Date(s)	Construction and Rehabilitation History
1939	A 750-ft-long rubble-mound breakwater (Figure 178) was constructed from the shore extending parallel to the entrance channel.
1965	The project was modified, which entailed removal of the existing breakwater and construction of a new 550-ft-long offshore rubble breakwater. The new structure would include an 8-ft crest width, 4-ton cover stone, a crest el of +8 ft lwd, and 1-V:1.5-H side slopes on the harbor side with 1-V:1.75-H side slopes on the lakeside (Figure 178).
1969	The 1965 modification to the project was reclassified into an inactive status based on an unfavorable benefit-to-cost ratio.
1986	The existing breakwater has never undergone maintenance during its lifetime and is considered presently to be in good condition.

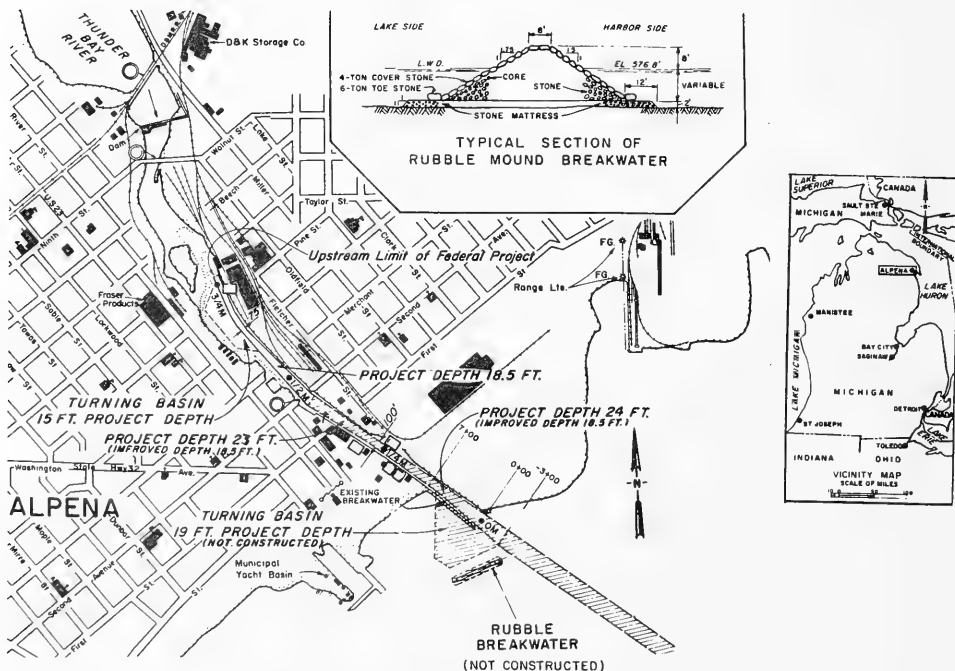
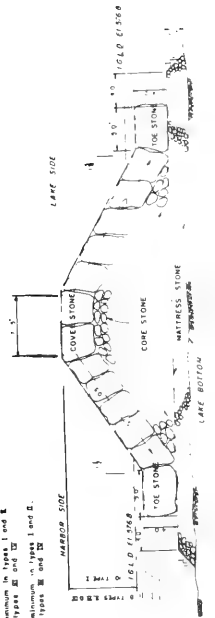


Figure 178. Alpena Harbor, Michigan

Table 66  
Harrisville Harbor Breakwaters  
Harrisville, Michigan

<u>Date(s)</u>	<u>Construction and Rehabilitation History</u>
1959	Construction of a 360-ft-long north breakwater and a 2,170-ft-long south breakwater was completed (Figure 179). The breakwater was constructed of rubble-mound materials with cover stones ranging to 3 (min) and 5 tons (min) for Types III and IV and Types I and II structures, respectively (Figure 179). The lakeward end of the south breakwater (Type I) had a crest el of +10 ft lwd, and the remaining portions of the structure (Types II, III, and IV) had a crest el of +8.0 ft lwd. The crest width was about 7.5 ft; and side slopes on the lakeside of the breakwaters were 1V:1.75H, while side slopes on the harbor side were 1V:1.5H. Toe stone ranged from 5 tons (min) in Types III and IV to 7 tons (min) in Types I and II.
1971	Replenishment of cover stone on the breakwaters was accomplished.
1984	An inspection of the breakwaters revealed some winter storm damage since several cover stones were missing. An estimated 80 tons of stone would be required to repair the breakwaters.
1985	Extensions of the north and south breakwaters of approximately 140 and 110 ft, respectively, were completed (Figure 179, hatched ends) for a cost of over \$433,000. Cover stones up to 9.5 tons were used.
1986	The breakwaters, presently, are considered in fair condition. An aerial photo of the Harrisville Harbor breakwaters (prior to breakwater extensions) is shown in Figure 180.

NOTE: (1) Max. 5 ton minimum in Types I and II.  
 (2) 3 ton minimum in Type III and IV.  
 (3) Max. 7 1/2 ton minimum in Types I and II.  
 (4) 5 ton minimum in Type III and IV.



TYPICAL CROSS SECTION OF BREAKWATERS

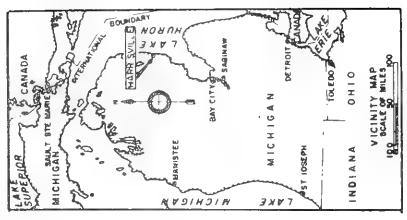
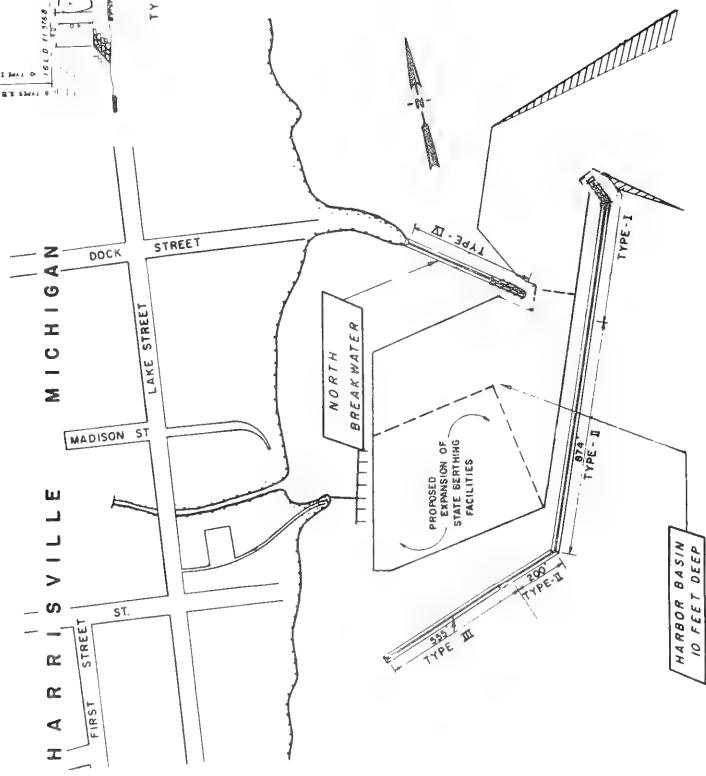


Figure 179. Harrisville Harbor, Michigan



Figure 180. Aerial view of Harrisville Harbor, Michigan

Table 67

Au Sable Harbor Jetties

Au Sable, Michigan

Date(s)	Construction and Rehabilitation History
1962	Construction of north and south jetties (Figure 181) was completed. The shoreward 980 ft of the north jetty and 1,000 ft of the south jetty were constructed with steel sheetpiling at a crest el of +8.0 ft lwd (Figure 182). The lakeward 227 ft of the north jetty and 200 ft of the south jetty were constructed with 27.2-ft diameter steel sheet-pile cells. The cells were stone filled and capped with concrete to an el of +8.0 ft lwd (Figure 182). Riprap was placed on each side of the cellular portions of the breakerwater (Figure 182) and along some portions of the steel sheet-pile structures (Figure 181).
1975	Rehabilitation of the north and south jetties was completed for a cost of about \$392,000. This work included repairs for broken and sunken cell caps and replenishment of riprap in various areas.
1984	An inspection of the jetties revealed them to be in very good condition. An aerial view of the Au Sable Harbor jetties is shown in Figure 183.

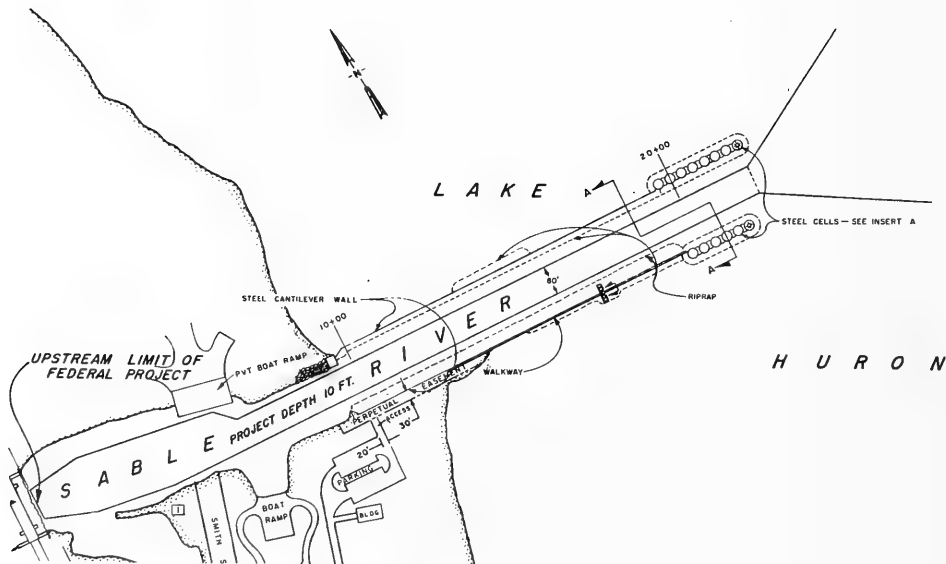
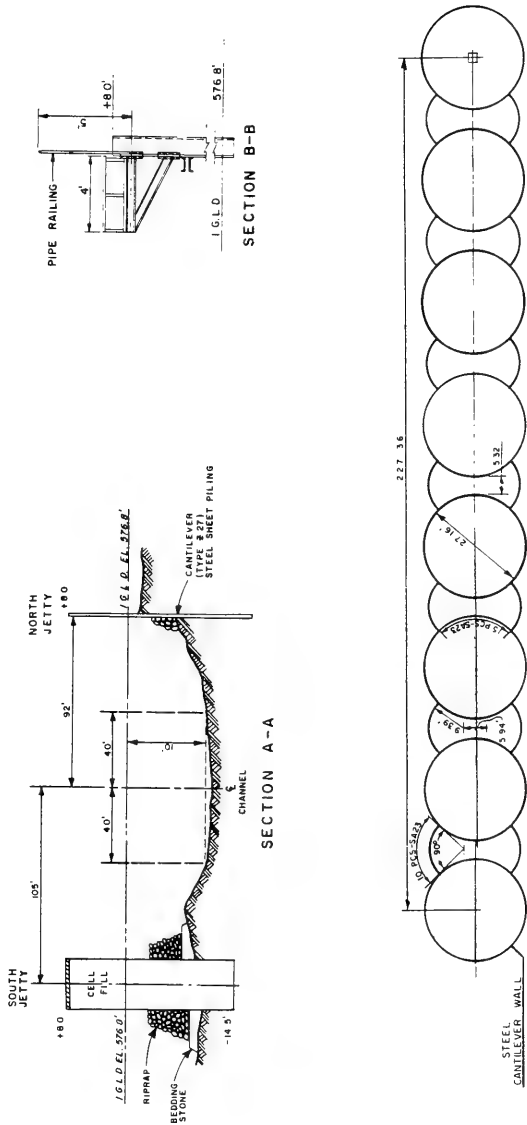


Figure 181. Au Sable Harbor, Michigan





NOTE SOUTH JETTY SIMILAR

Figure 182. Typical structure section and plan views, Au Sable Harbor, Michigan



Figure 183. Aerial view of Au Sable Harbor, Michigan

Table 68

Tawas Bay Harbor BreakwaterTawas Bay, Michigan

<u>Date(s)</u>	<u>Construction and Rehabilitation History</u>
1977	Construction of a breakwater having four interconnected sections with an aggregate length of 1,564 ft (Figure 184) extending bayward from an existing timber state-owned pier was completed. The breakwater consisted of steel sheetpiling spaced to form a structure 24 ft in width. The structure was sand filled and capped with precast concrete at a crest el of +7.25 ft lwd. The sheetpiling was extended to an el of +10.5 lwd on the bay side. Riprap ranging from 50-400 lb was also placed on the bay side (Figure 184).
1985	An inspection of the site indicated the breakwater to be in very good condition. No maintenance has been performed on the breakwater since its construction. An aerial photograph of the Tawas Harbor breakwater is shown in Figure 185.





Figure 185. Aerial view of Tawas Bay Harbor, Michigan

Table 69

Point Lookout Harbor BreakwatersAu Gres, Michigan

Date(s)	Construction and Rehabilitation History
1972	Construction of a 4,000-ft-long east and a 3,800-ft-long west breakwater was completed. The breakwaters were rubble-mound structures extending parallel into Saginaw Bay (Figure 186). They consisted of cover stone laid on excavated material. Cover stone on the channel sides consisted of 1/4-ton (min) material, and cover stone on the bay sides of the breakwaters consisted of 3/4-ton (min) material. The breakwaters had 10-ft crest widths and side slopes of 1V:3H for the east breakwater and 1V:2.5H for the west structure. The crest el of the east breakwater ranged from +9 to +12 ft lwd, and the west breakwater had a crest el ranging from +6 to +9 ft lwd (Figure 186).
1976	Approximately 1,300 tons of cover stone (1,500-300 lb) was placed along the bay side of the east breakwater in critical areas to prevent failure of the structure.
1978	Approximately 500 tons of cover stone (3/4 to 1 ton) was placed along the bay side of the west breakwater in areas to maintain stability and prevent failure.
1986	Stone was placed at the harbor, and the structures are currently in good condition. An aerial photograph (photo taken in 1981) of the Point Lookout Harbor breakwaters is shown in Figure 187.





Figure 187. Aerial view of Point Lookout Harbor, Au Gres, Michigan



Table 70

Caseville Harbor Breakwater

Caseville, Michigan

Date(s)	Construction and Rehabilitation History
1964	Construction of a 1,780-ft-long rubble-mound breakwater (Figure 188) was completed. The structure had an 8-ft crest width, 1-V:1.5-H side slopes on the channel side, and 1-V:1.75-H side slopes on the lake-side (Figure 188). The lakeward 1,000-ft length (Section I) had a crest el of +8.0 ft lwd and 2-ton (min) cover stone, while the shoreward 780-ft section (Section II) included a crest el of +6.0 ft lwd and cover stone that was 1 ton (min).
1980	Repair of the rubble-mound breakwater was performed.
1986	The structure presently is considered to be in good condition. An aerial view of the Caseville Harbor breakwater is shown in Figure 189.

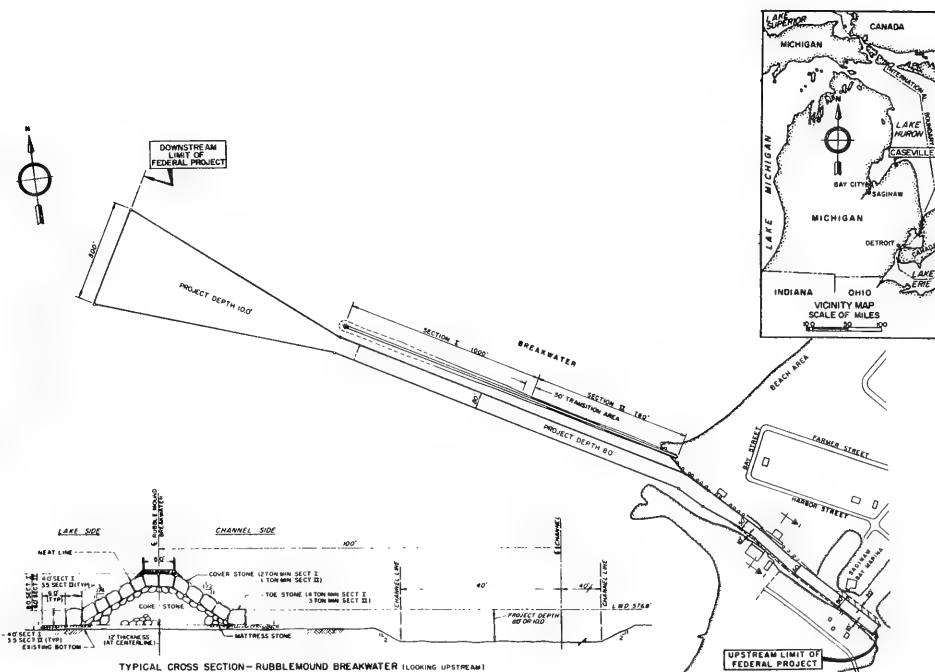


Figure 188. Caseville Harbor, Michigan



Figure 189. Aerial view of Caseville Harbor, Michigan

Table 71  
Port Austin Harbor Breakwater  
Port Austin, Michigan

<u>Date(s)</u>	<u>Construction and Rehabilitation History</u>
1959	Construction of a 1,926-ft-long offshore breakwater (Figure 190) was completed. The breakwater was built with cellular steel sheetpiling which ranged from 15.3 (Type D) to 30.4 ft (Type A) in diameter (Figure 190). The cells were filled with sand and gravel and crowned with a bituminous cap. The crest el of the breakwater was +10 ft lwd for Types A and B and +8 ft lwd for Types C and D. Riprap was placed along the sides of the cellular breakwater except on the harbor side of Types C and D.
1979	The lakeward cells (Types A and B) were replenished with stone and capped with concrete.
1983	The shoreward cells (Types C and D) revealed hairline cracks in the asphalt which were sealed. Caulking of construction joints in the breakwater also was performed.
1986	A safety railing was installed on the structure. The breakwater is considered to be in good condition; however, some construction joints are separating and require repairs. An aerial view of the Port Austin breakwater is shown in Figure 191.





Figure 191. Aerial view of Port Austin Harbor, Michigan

Table 72

Harbor Beach BreakwatersHarbor Beach, Michigan

Date(s)	Construction and Rehabilitation History
1874- 1885	Construction of a 1,204-ft-long north breakwater, a 4,716-ft-long main breakwater, and a 1,956-ft-long south breakwater (Figure 192) was completed during this period. The breakwaters were constructed with stone-filled timber cribs which ranged from 16 to 38 ft in width (Figure 193).
1905- 1909	The main breakwater was capped with a stone and concrete superstructure (Figure 193, Cross Sections D-D and E-E). The superstructure included a parapet that had a crest el of +16.5 ft lwd.
1911- 1912	The north breakwater was capped with a concrete superstructure (Figure 193, Cross Sections A-A and B-B). The breakwater crest el was established at +8.0 ft lwd.
1916- 1917	The south breakwater was capped with a concrete superstructure (Figure 193, Cross Sections F-F through I-I). The crest el of most of the structure was +8.0 ft lwd, but the northern end of the breakwater (Cross-Section F-F) included a parapet with an el of +14 ft lwd.
1916- 1919	Riprap was placed on the lakeside of the main breakwater (Figure 193, Cross Sections D-D and E-E). It was placed on a 1-V:1.5-H slope with a crest ranging from about +3 ft lwd (Cross Section D-D) to +6.5 ft lwd (Cross Section E-E).
1921	Riprap was placed on each side of the south breakwater (Figure 193, Cross Sections F-F through I-I). The crest of the riprap on the lakeside was +8.0 ft lwd, and on the harbor side it was at an el of +3.5 ft lwd.
1925- 1926	Riprap was placed on the lakeside of a portion of the north breakwater (Figure 193, Cross Section B-B) to an el of about +3.5 ft lwd.
1966	Rehabilitation of the south end of the main breakwater (Figure 192, Cross Section E-E) was performed. Work consisted of replenishing stone fill and repairing cracks in the substructures. Cost of the repairs was about \$172,000.
1971	Rehabilitation of portions of the south breakwater (Figure 192, Cross Sections F-F through H-H) was completed. Riprap protection which included a total of approximately 38,500 tons of stone (ranging from 6 to 15 tons each) was performed for about \$676,000.
1975	Riprap was replenished along portions of the main breakwater.

(Continued)

Table 72 (Concluded)

Date(s)	Construction and Rehabilitation History
1981	Riprap was replenished along portions of the north breakwater, and cracks in the superstructure were repaired.
1985	An inspection of the site indicated the structures are in need of major rehabilitation. The timber cribbing of the substructures is collapsing under the weight of the concrete superstructures resulting in shifting and cracking of the superstructure. The breakwaters are considered to be in poor condition, and major rehabilitation has been recommended for the harbor to maintain its protective status. An aerial view of the Harbor Beach breakwaters is shown in Figure 194.

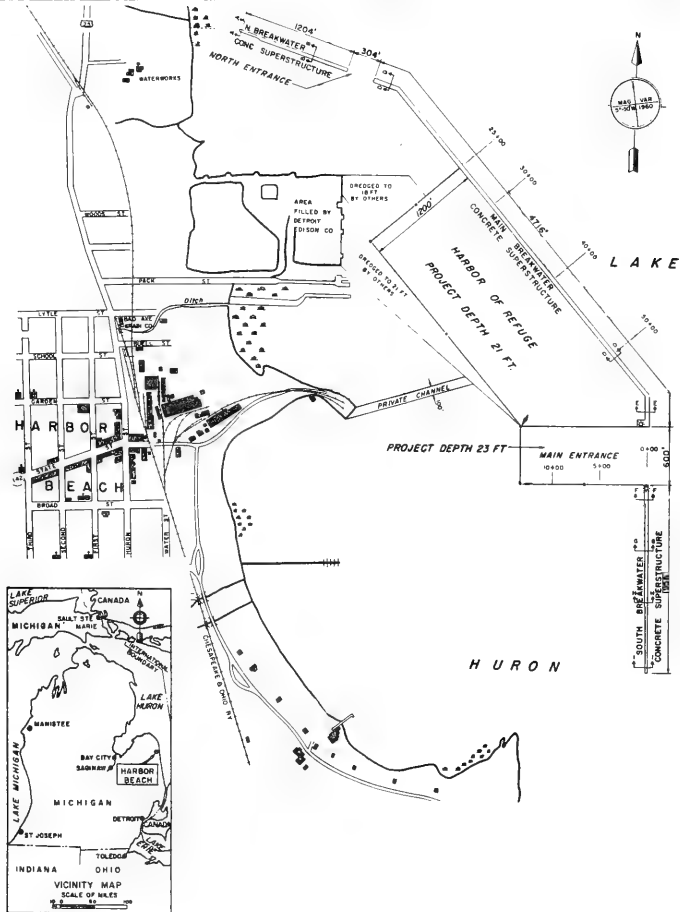


Figure 192. Harbor Beach, Michigan

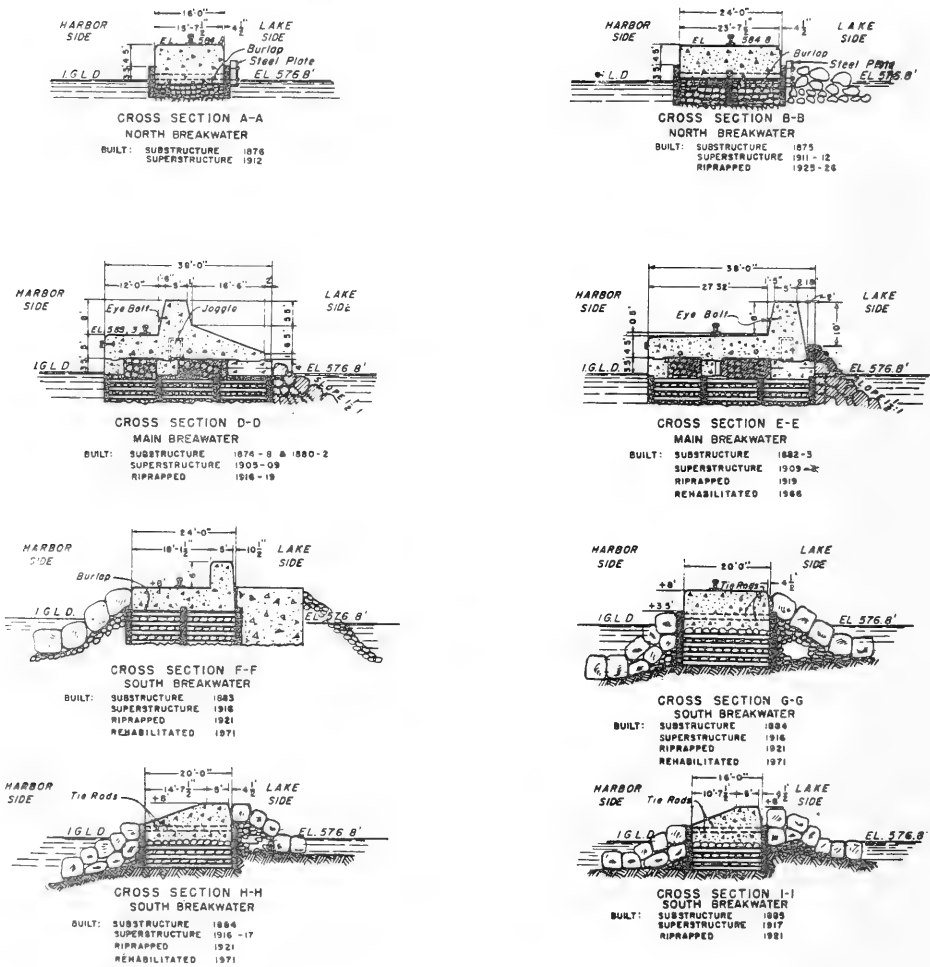


Figure 193. Typical breakwater cross sections, Harbor Beach, Michigan



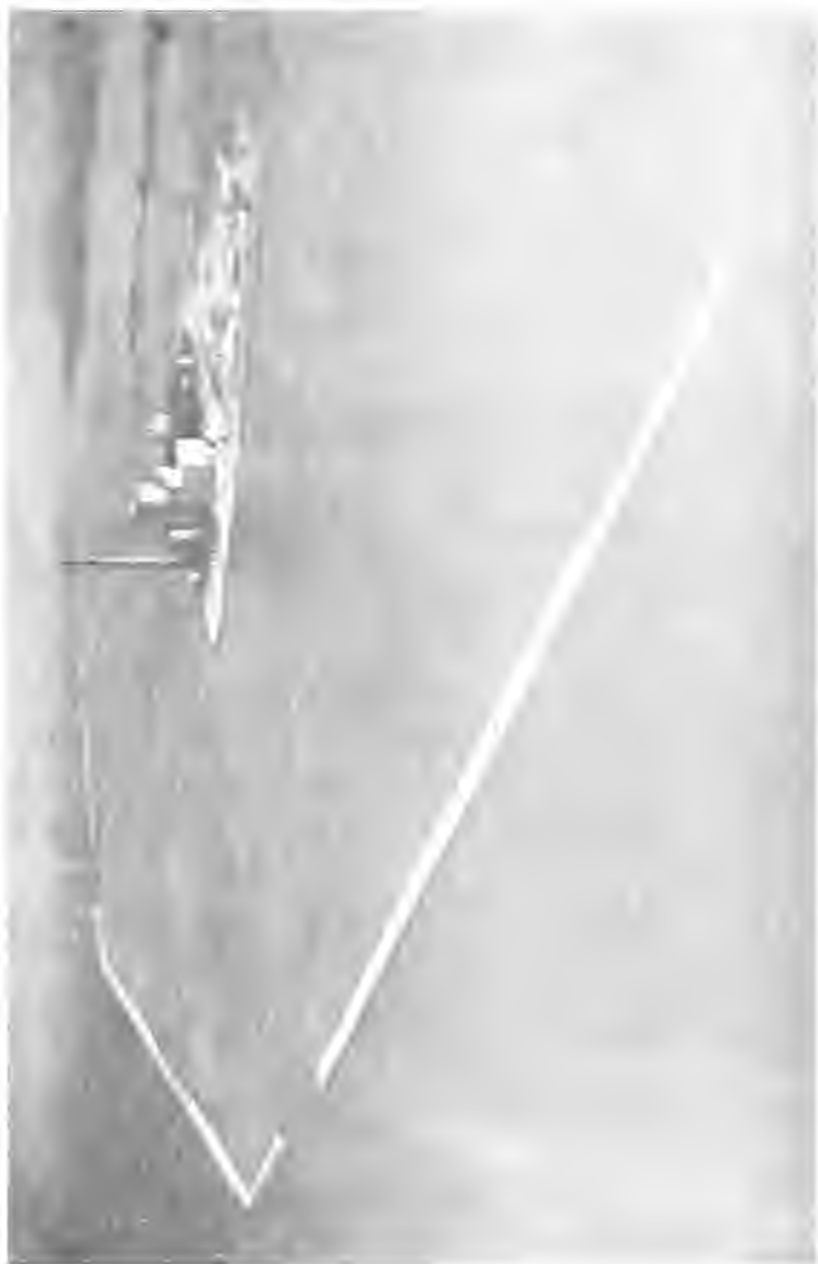


Figure 194. Aerial view of Harbor Beach, Michigan

Table 73

Port Sanilac Harbor BreakwatersPort Sanilac, Michigan

Date(s)	Construction and Rehabilitation History
1951	Construction of a 1,230-ft-long north breakwater and a 949-ft-long south breakwater (Figure 195, Types A, B, C, and D) was completed. The shoreward ends of both structures consisted of steel sheetpiling with an el of +8.0 ft lwd (Figure 196, Type D). Riprap was placed on the lakesides of the structures. The remaining portions of the breakwaters were constructed of sand- and gravel-filled cellular steel sheet-pile structures with cell diameters ranging from 23.87 (Figure 196, Type A) to 28.85 ft (Figure 196, Types B and C). The Type C structure at the lakeward end of the north breakwater (Figure 196) had a crest el of +10 ft lwd, and the remaining portions (Types A and B) were installed at a +8 ft lwd crest el. Riprap was placed on both sides of the lakeward portion of the north breakwater (Type C) and on only the lakesides of the cells of the remaining structures (Types A and B). The cells were capped with asphalt.
1975	To reduce wave heights in the harbor to approximately one-half foot, a 327-ft-long extension to the north breakwater and a 69-ft-long extension of the south breakwater (Figure 195, Types E and F) was completed. The north breakwater extension consisted of stone-filled, steel sheet-pile cells with a diameter of 43 ft and a crest el of +10 ft lwd (Figure 196, Type E). The south breakwater extension was constructed of stone-filled cellular sheet piles (Figure 196, Type F) with diameters of 31.8 ft and a crest el of +8 ft lwd. The extensions were capped with bituminous concrete. Riprap stone ranging from 1,000 lb to 1 ton was placed on both sides of the north breakwater extension and on the lakeside of the south extension.
1984	A site inspection of the structures revealed that some of the asphalt caps of the north breakwater had settled, but the breakwaters were generally in good condition. An aerial view of the Port Sanilac Harbor breakwaters is shown in Figure 197.

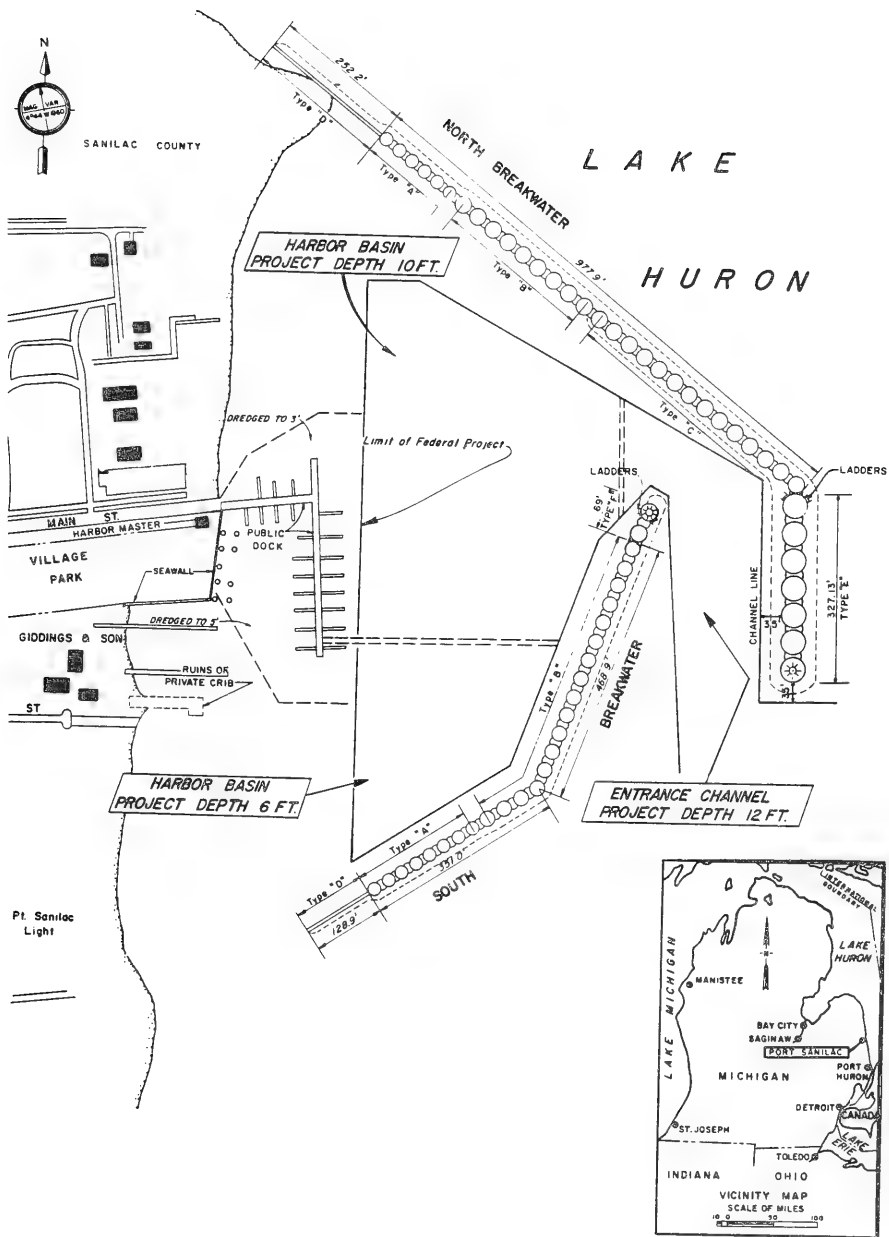
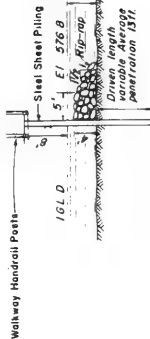
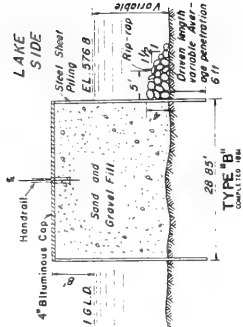
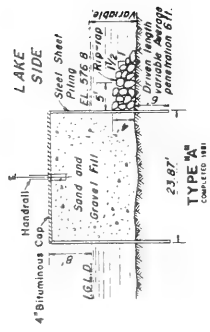


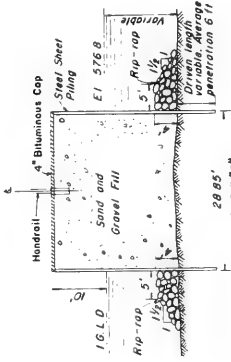
Figure 195. Port Sanilac Harbor, Michigan



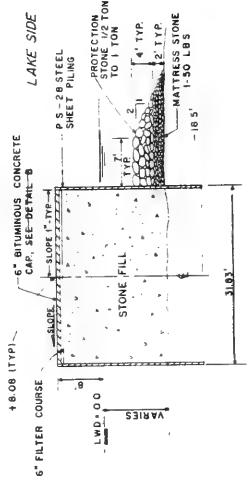
TYPE "D"  
COMPLETED 1948



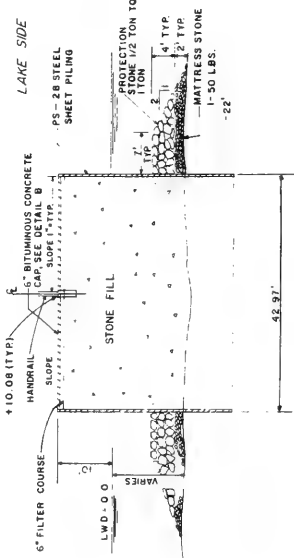
TYPE "A"  
COMPLETED 1948



TYPE "C"  
COMPLETED 1948



TYPE "F"



TYPE "E"

Figure 196. Typical structure cross sections, Port Sanilac Harbor, Michigan



Figure 197. Aerial view of Port Sanilac Harbor, Michigan

Table 74  
Lexington Harbor Breakwaters  
Lexington, Michigan

<u>Date(s)</u>	<u>Construction and Rehabilitation History</u>
1976	Construction of a 1,905-ft-long north breakwater and a 690-ft-long south breakwater (Figure 198) was completed. The north breakwater was a rubble-mound structure with a 15-ft-wide crest and 1-V:1.5-H side slopes. The crest el was +9.5 ft lwd for the shoreward 300-ft length and +11.5 ft lwd for the remaining portions of the structure (Figure 199). Cover stone ranging from 4.5 to 16 tons was used. The south breakwater was a rubble-mound structure also with a crest el of +8 ft lwd and a crest width of 8 ft (Figure 199). Side slopes of 1V:1.5H and cover stone ranging from 350 to 850 lb were utilized.
1984	A site inspection of the breakwaters indicated that they were in very good condition. An aerial view of the Lexington Harbor breakwaters is shown in Figure 200.

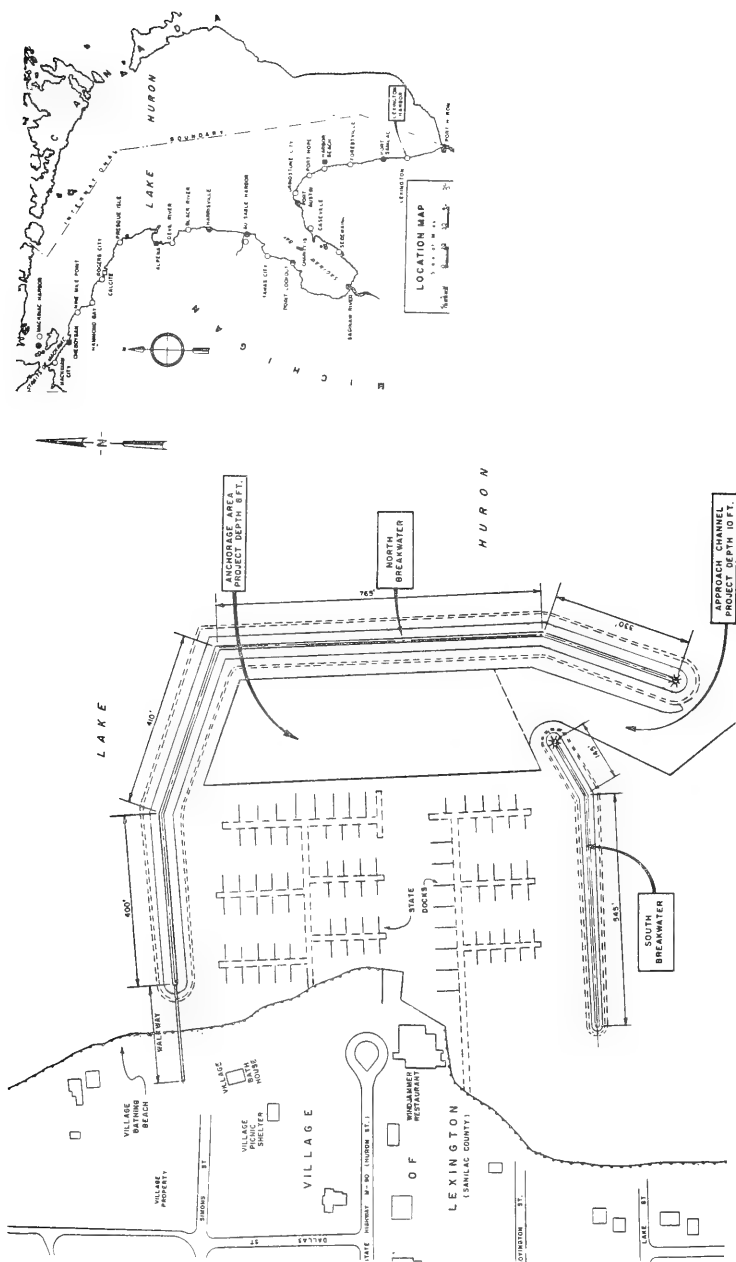
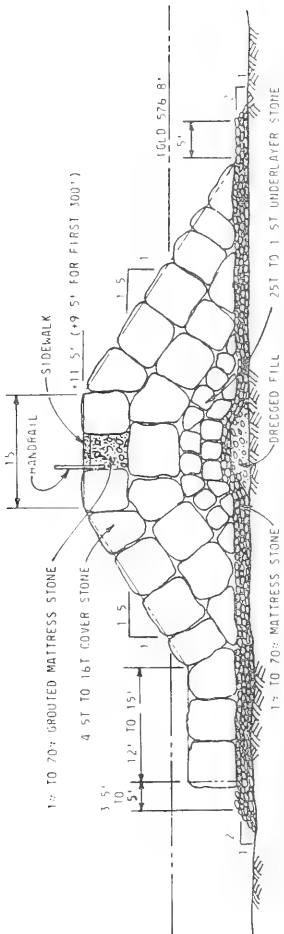
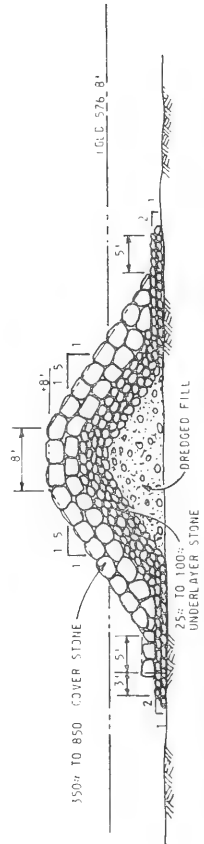


Figure 198. Lexington Harbor, Michigan



TYPICAL CROSS SECTION NORTH BREAKWATER  
BUILT 1976



TYPICAL CROSS SECTION SOUTH BREAKWATER  
BUILT 1976

Figure 199. Typical breakwater cross sections, Lexington Harbor, Michigan

S I D E F A K A L





Figure 200. Aerial view of Lexington Harbor, Michigan

Table 75

Clinton River Breakwater

Clinton River, Michigan

Date(s)	Construction and Rehabilitation History
1966	Construction of a 1,400-ft-long rubble-mound breakwater north of the river entrance and an earth fill (Figure 201) was completed. The breakwater had a +6.1 ft lwd crest el, an 8-ft-wide crest width, and 1-V:1.5-H side slopes (Figure 201). Cover stone ranged from 1,000 lb to 1 ton.
1986	There is no record of breakwater maintenance, and the structure presently is in good condition. An aerial photograph of the Clinton River breakwater is shown in Figure 202.

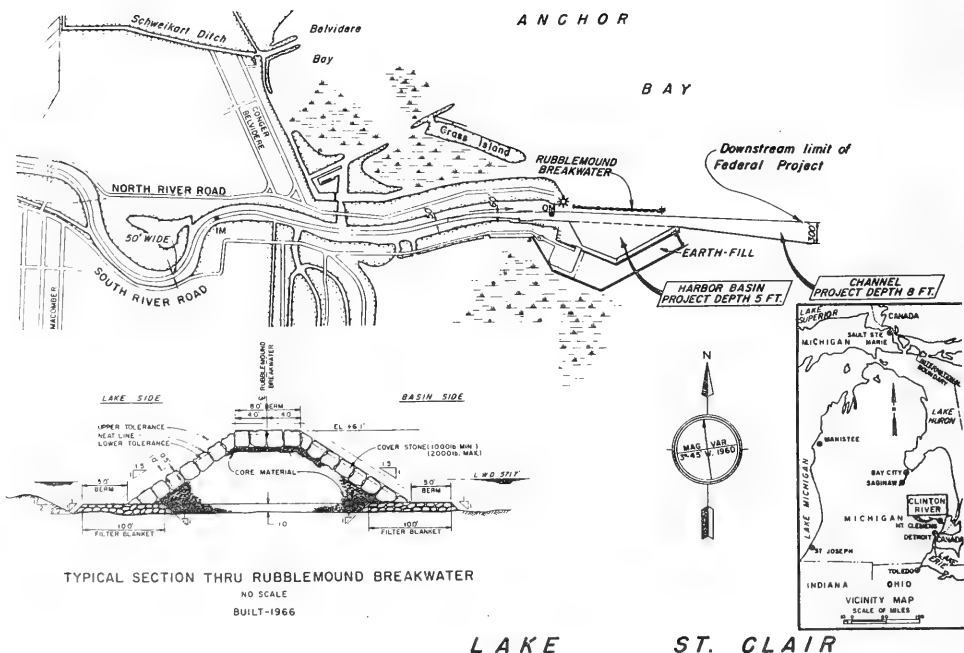


Figure 201. Clinton River Harbor, Michigan



Figure 202. Aerial view of Clinton River Harbor, Michigan

Table 76

Bolles Harbor Jetty  
Bolles Harbor, Michigan

Date(s)	Construction and Rehabilitation History
1970	Construction of a 400-ft-long rubble-mound jetty west of the entrance and a disposal site (Figure 203) was completed. The jetty had a 10-ft crest width and an el of +7.0 ft lwd (Figure 203). It included side slopes of 1V:2H and armor stone ranging from 700 to 1,600 lb.
1984	An inspection of the site indicated the jetty was in good condition. There is no record of jetty maintenance.

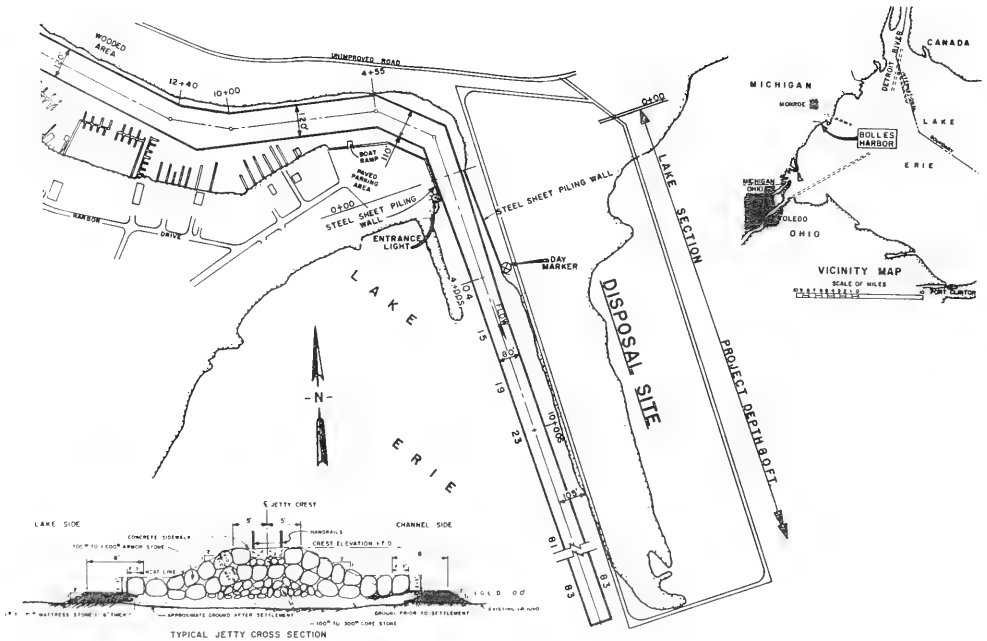
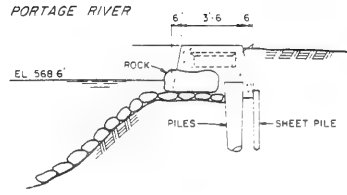
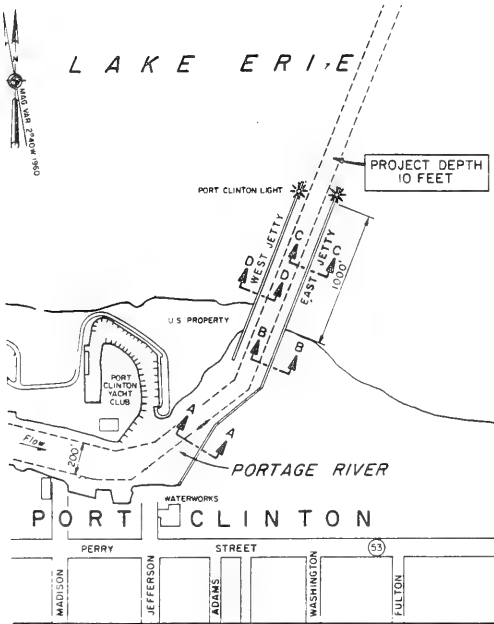
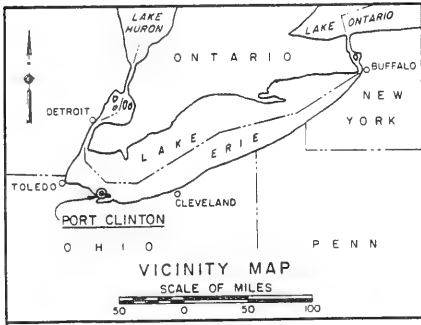


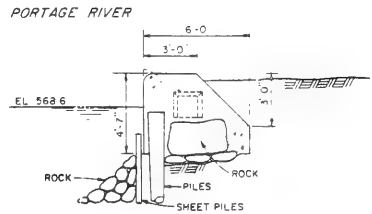
Figure 203. Bolles Harbor, Michigan

Table 77  
Port Clinton Harbor Jetties  
Port Clinton, Ohio

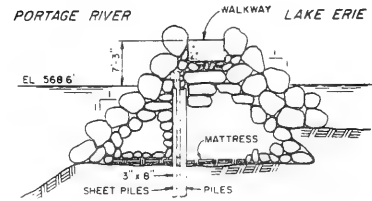
<u>Date(s)</u>	<u>Construction and Rehabilitation History</u>
1893	Construction of parallel jetties extending lakeward from the mouth of the Portage River (Figure 204) was completed. The original lengths of the east and west jetties were 2,200 and 1,980 ft, respectively. The jetties were constructed of woodpiling and stone. Side slopes of the rubble portions of the structures were 1V:1H.
1963	Breakwater repairs were completed for a cost of \$12,240.
1973	Placement of stone on various portions of the east jetty was completed to repair areas that were washed out and damaged by a large storm in 1972. The cost of these repairs was \$128,860.
1980	An inspection of the site indicated the structures were in very poor condition with the exception of the areas that were repaired in 1973. The jetties were badly deteriorated and sheet pile and additional stone was recommended. It was also recommended that 850 ft of the shore arm of the west jetty be deauthorized since much of it was settled badly and/or buried and it was not considered necessary for shore protection. This deauthorization would result in a west jetty length of 1,130 ft as shown in Figure 204.
1982	Repair of damaged areas of the east jetty was completed. Damaged areas were overlaid with stone similar to that used during construction in 1973. Steel sheetpiling and a concrete cap were installed on the portion of the jetty adjacent to the overbank, and a concrete walkway was installed on the structure originating at the shoreline and extending 1,000 ft lakeward (Figure 204). The crest el of the concrete cap ranged from +3 to +5 ft lwd, and the el of the walkway was +7.25 ft lwd.
1983- 1984	Repairs to the west jetty were completed. Armor stone was placed along the lakeside and the crest of the existing jetty. These stones ranged from 0.5 to 3.5 tons. The crest el after the repairs was +7.3 ft lwd.
1986	The structures are presently considered to be in good condition. An aerial view of the Port Clinton Harbor Jetties is shown in Figure 205.



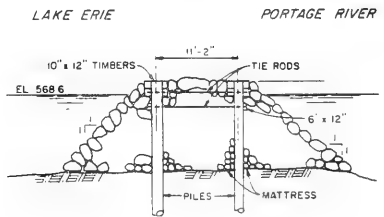
SECTION A-A



SECTION B-B



SECTION C-C



SECTION D-D

Figure 204. Port Clinton Harbor, Ohio



Figure 205. Aerial view of Port Clinton Harbor, Ohio

West Harbor Breakwaters  
Ottawa County, Ohio

Date(s)	Construction and Rehabilitation History
1982	Construction of two breakwaters in an arrowhead configuration extending lakeward on each side of the natural entrance (Figure 206) was completed. The north and south breakwaters were rubble-mound structures with lengths of 1,350 and 1,575 ft, respectively. The structures had 10-ft-wide crest widths and els of +6.9 ft lwd (Figure 207). Armor stone ranged from 1 to 3 tons, and side slopes were 1V:1.5H on the breakwater trunks and 1V:3H at the heads.
1986	There is no record of maintenance or repairs to the breakwaters, and they presently are considered to be in good condition. An aerial view of the West Harbor breakwaters is shown in Figure 208.

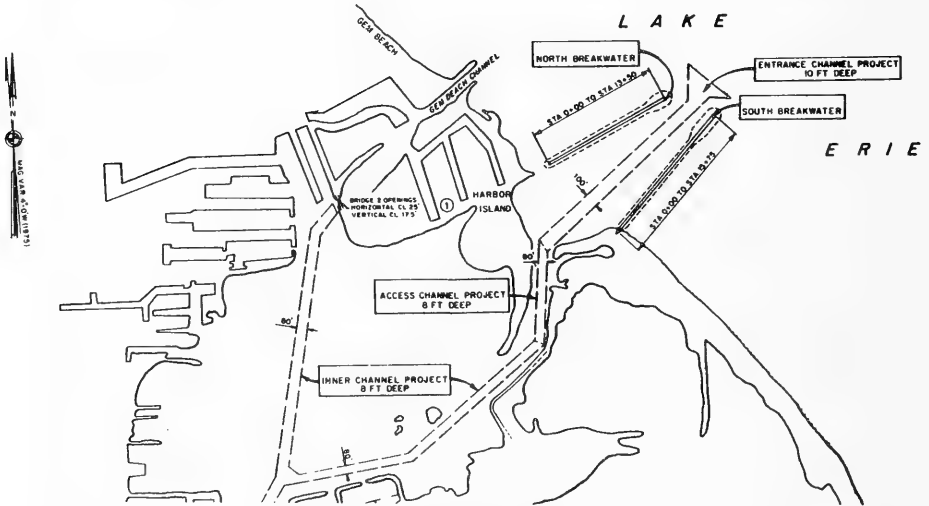
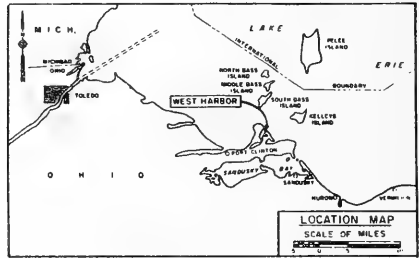
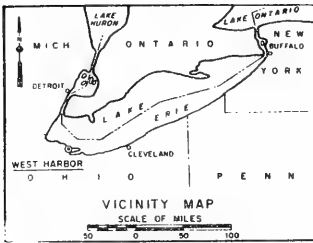
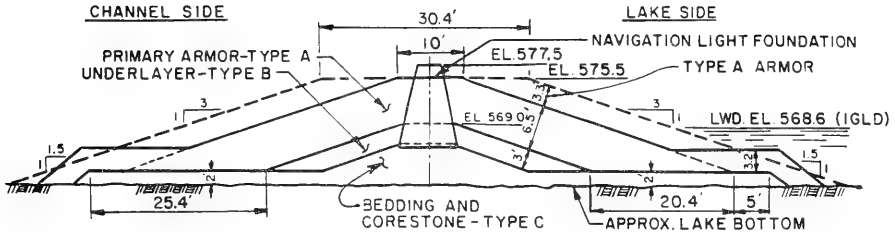


Figure 206. West Harbor, Ohio

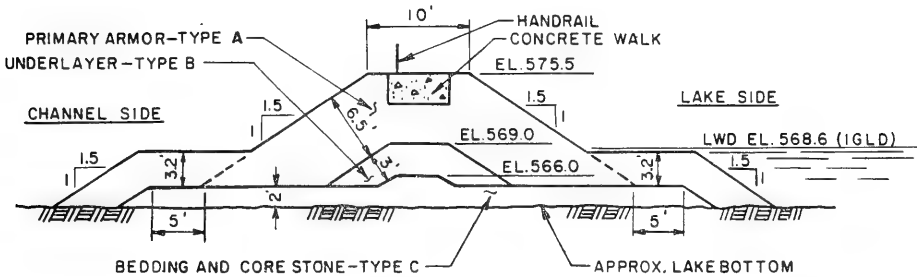


### STONE GRADATION

TYPE "A" STONE	1-3 TONS
TYPE "B" STONE	200-700 POUNDS
TYPE "C" STONE	0.5-50 POUNDS



STA. 0+00 TO 1+00 ARMOR LAYER 9.8FT. THICK (NORTH AND SOUTH BKW)  
 STA. 1+00 TO 2+00 ARMOR LAYER 6.5FT. THICK (SOUTH ONLY)



### TYPICAL BREAKWATER SECTIONS

Figure 207. Typical breakwater cross sections, West Harbor, Ohio



Figure 208. Aerial view of West Harbor, Ohio

Table 79

Sandusky Harbor East Jetty  
Sandusky, Ohio

Date(s)	Construction and Rehabilitation History
1897-1922	Construction of a 6,000-ft-long rubble-mound east jetty was completed (Figure 209) during this time. The jetty had a 10-ft-wide crest with an el of +6.0 ft lwd and side slopes of 1V:1.5H. Armor stone used from an el of about -2 ft lwd to the crest had a minimum weight of 2 tons. Stone used below this el (-2 ft lwd) had a minimum weight of 500 lb and not less than 50 percent was 2 tons or more.
1963-1964	Rehabilitation of the lakeward 4,000-ft portion of the jetty was completed during this time. The el of the jetty was raised to its authorized height of +6 ft lwd. Armor stone with a minimum weight of 4 tons each was used.
1985	The east jetty was considered to be in poor condition, and repairs were recommended. Estimated costs of these repairs were about \$84,000.

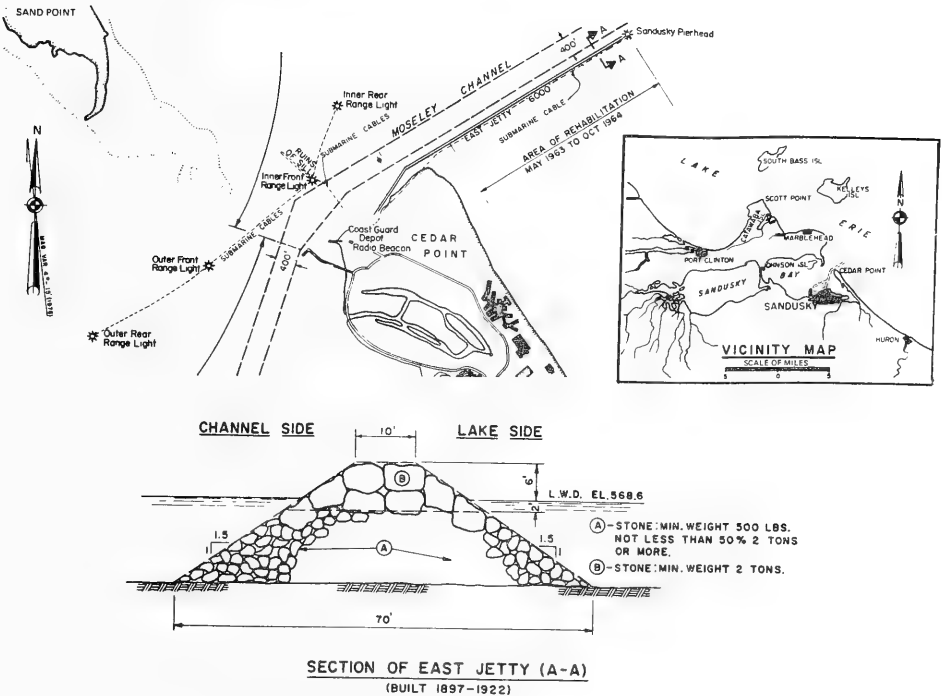


Figure 209. Sandusky Harbor, Ohio

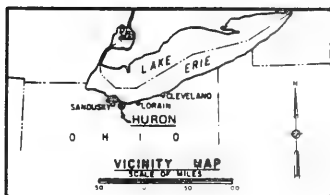
Table 80  
Huron Harbor Structures  
Huron, Ohio

Date(s)	Construction and Rehabilitation History
1827- 1831	Construction of an 800-ft-long west pier (Figure 210, Section A) was completed. The pier was a 20-ft-wide stone-filled timber crib structure (Figure 211, Section A).
1891- 1894	A 973-ft-long extension of the west pier (Figure 210, Sections C and G) was completed. The extension consisted of a stone-filled timber crib structure that ranged from 16 to 20 ft in width (Figure 211, Section C).
1907- 1908	Construction of a 1,450-ft-long rubble-mound east breakwater (Figure 210, Section B) was completed during this time. The breakwater had a crest width of 10 ft and an el of +10.3 ft lwd (Figure 212, Section B). Side slopes were 1V:2H on the lakeside and 1V:1.34 on the harbor side. A concrete and stone superstructure was installed on a portion of the west pier (Figures 210 and 211, Section C) also during this period of time. The crest el of the pier was +8.3 ft lwd.
1914	A 280-ft-long shoreward extension of the west pier (Figure 210, Sections D and F) was completed. The lakeward portion of the extension involved woodpilings driven about 15 ft apart and filled with stone (Figure 212, Section D). The extension was capped with larger stone (5-ton minimum) and had a crest el of about +6.0 ft lwd. The adjacent 160-ft-long shoreward portion of the extension (Figure 212, Section F) was a rubble-mound structure with a crest width of 5 ft and an el of +5 ft lwd. Side slopes were 1V:1H.
1925	A concrete superstructure was installed on an 800-ft-long portion of the west pier (Figures 210 and 211, Section A). The crest el of this portion of the pier was +6.3 ft lwd.
1930	The shoreward rubble-mound portion of the west pier constructed in 1914 (Figures 210 and 212, Section F) was repaired and extended shoreward an additional 110 ft.
1933- 1934	A 1,360-ft-long rubble-mound extension of the west pier (Figure 210, Section E) was constructed during this period. The breakwater had a crest width of about 8 ft and an el of +8 ft lwd. Side slopes were 1V:1.3H (Figure 211, Section E). Armor stones with a minimum weight of 3 tons, and not less than 50 percent being 5 tons or more, were used.
1950	A 242-ft-long portion of the west pier was repaired by encasing it with steel sheetpiling (Figures 210 and 211, Section C). The voids between the sheetpiling and the existing structure were filled with

(Continued)

Table 80 (Concluded)

Date(s)	Construction and Rehabilitation History
	stone and a concrete cap was installed. The width of the pier varied from 24 to 28 ft, and the crest el ranged from +8.4 to +9.4 ft lwd.
1957	A 341-ft-long portion of the west pier was repaired (Figures 210 and 211, Section C) in the same manner as the 1950 repairs.
1963	A 390-ft-long portion of the west pier was repaired (Figures 210 and 211, Section G) in a manner similar to the 1950 and 1951 repairs. The structure width, however, was 34.7 ft, and the crest el was +8.75 ft.
1975	Reconstruction of the portion of the west pier adjacent to the Corps disposal area (Figure 210) was completed. The rubble-mound portion of the pier (Section E) was raised to an el of +15.25 ft lwd and had a crest el of 8 ft (Figure 211). The steel sheet-pile encased portion of the pier (Sections C and G) included the installation of stone adjacent to the containment side of the pier (Figure 211). The crest el of the stone structure was 10.25 ft lwd, and the crest width was 8.5 ft. A parapet was installed at an el of +11.0 ft on the encased structure adjacent to the stone crest.
1984	Many repairs have been performed during the structure's lifetime, and they are considered to be in fair condition. An aerial photo of the Huron Harbor structures is shown in Figure 213.



L A K E

E R I E

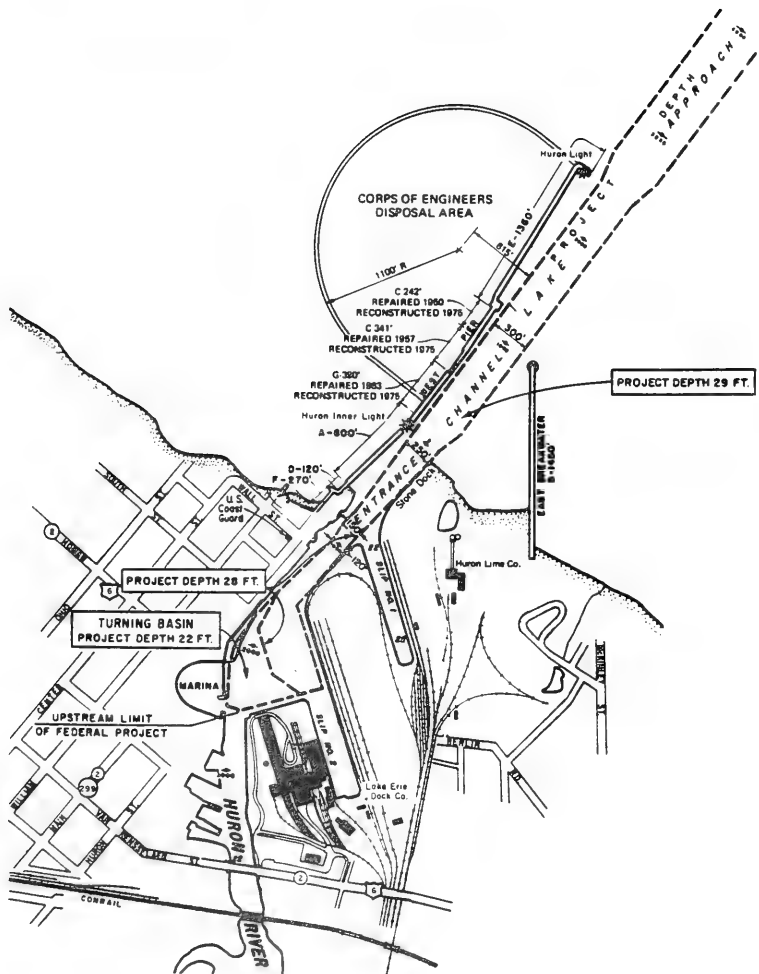
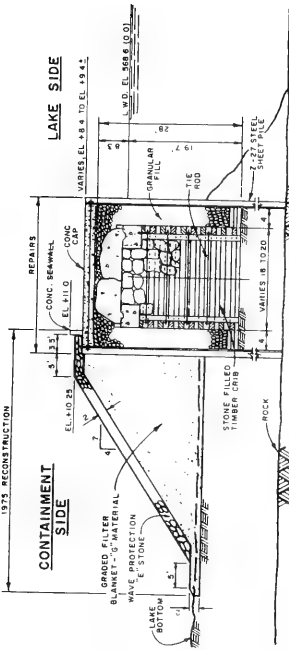


Figure 210. Huron Harbor, Ohio



**SECTION OF WEST PIER AT C-**

(BUILT 1891 - 1894)  
SUPERSTRUCTURE 1907-1908  
REBUILT 242 FEET OF PIER 1950  
REBUILT 341 FEET OF PIER 1957  
FILTER BLANKET, WAVE PROTECTION  
AND SEAWALL ADDED IN 1975

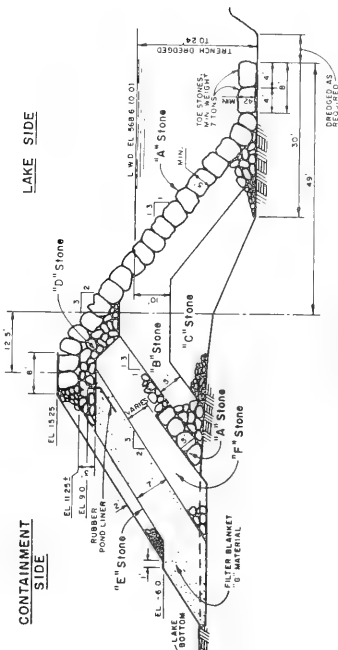






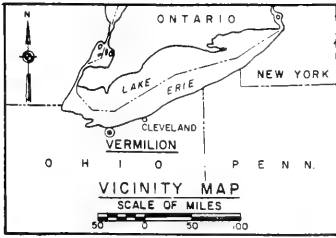


Figure 213. Aerial view of Huron Harbor, Ohio

Table 81

Vermilion Harbor StructuresVermilion, Ohio

Date(s)	Construction and Rehabilitation History
1836- 1839	Construction of parallel piers at the mouth of the Vermilion River was completed. The piers extended to the -10 ft lwd contour and had crest els of about +5.0 ft lwd. They were stone-filled timber crib structures, and were 16 ft in width.
1874	The east and west piers were extended to the -12 ft lwd contour. No other lakeward extensions have been made. The east pier is 458.5 ft long, and the west pier is 1,333.5 ft long (Figure 214).
1906- 1914	A heavy stone superstructure was installed on both piers (Figure 215) to els ranging from +6 to +6.5 ft lwd. The crest width was 10 ft.
1964	Rehabilitation of 450 ft of the west pier and 230 ft of the east pier was completed (Figures 214 and 215). The crest els of these portions were raised to +6.5 ft lwd, and riprap was installed on the lakesides of the structures.
1973	Construction of an 864-ft-long detached breakwater (Figure 214) was completed. The breakwater was a cellular steel sheet-pile structure with 35-ft diameter cells. The cells were granular filled and capped with concrete at an el of +10 ft lwd (Figure 215). The offshore breakwater was model tested (Brasfield 1970) prior to construction.
1986	The structures presently are considered in good condition. An aerial view of the Vermilion Harbor structures is shown in Figure 216.



L A K E E R I E

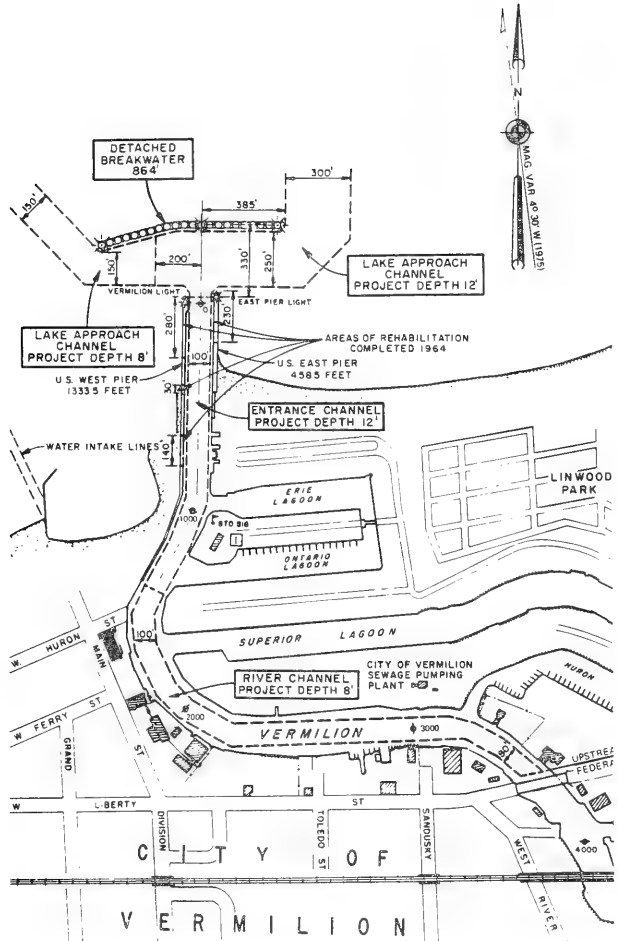
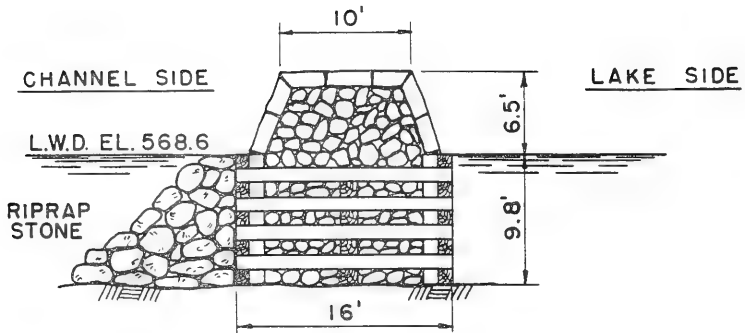


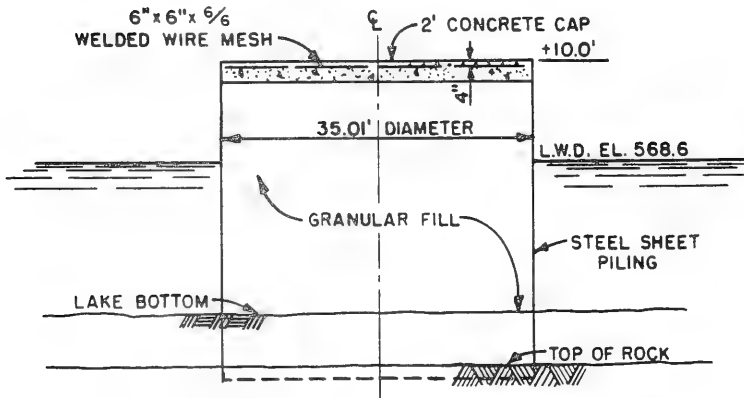
Figure 214. Vermilion Harbor, Ohio



SECTION OF EAST PIER

WEST PIER SIMILAR BUT OPPOSITE HAND  
(BUILT 1836 - 1839, REBUILT 1906 - 1914)

REHABILITATION OF 450 FEET OF WEST PIER  
AND 230 FEET OF EAST PIER INITIATED IN  
JUNE 1964 AND COMPLETED IN OCTOBER 1964.  
(TOP ELEVATION RAISED TO 6.5 FEET ABOVE  
L.W.D. AND RIPRAP STONE PLACED ON LAKE  
SIDE.)



DETACHED BREAKWATER

(BUILT 1973)

Figure 215. Typical structure cross sections,  
Vermilion Harbor, Ohio



Figure 216. Aerial view of Vermilion Harbor, Ohio

Table 82

Lakeview Park Breakwaters

Lorain, Ohio

Date(s)	Construction and Rehabilitation History
1977	Construction of three 250-ft-long offshore breakwaters was completed at the site (Figure 217). The breakwaters were rubble-mound structures with +8 ft lwd crest els and 14-ft-wide crest widths (Figure 217). Side slopes were 1V:1.5H, and armor stone ranged from 4.5 (min) to 10 tons (max).
1982	Model tests (Bottin 1982a) were conducted to determine causes of erosion of the beach fill. Improvement plans consisted of modifications to the west end of the west breakwater and the west groin.
1986	There is no record of repairs to the breakwaters, nor have any improvements been made. The breakwaters are in good condition. An aerial view of the Lakeview Park breakwaters is shown in Figure 218.

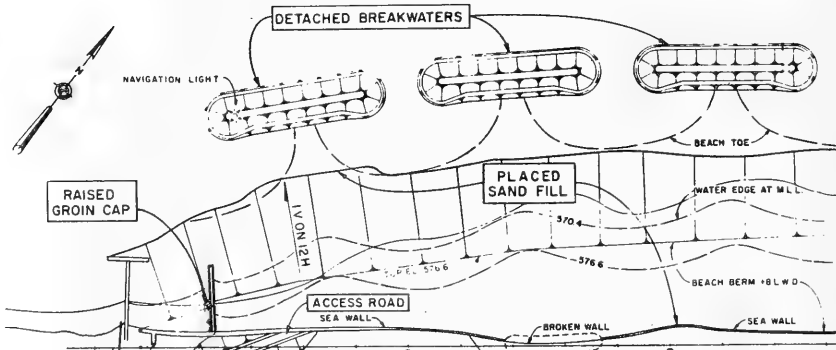
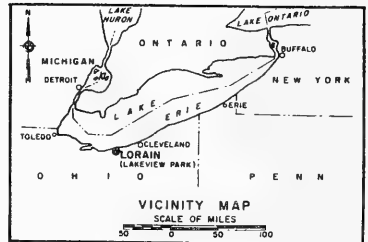
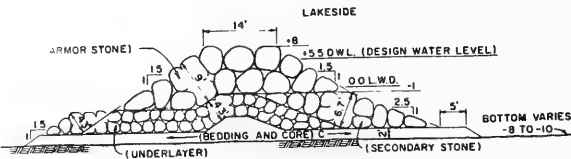


Figure 217. Lakeview Park, Ohio



Figure 218. Aerial view of Lakeview Park, Ohio

Table 83

Lorain Harbor StructuresLorain, Ohio

Date(s)	Construction and Rehabilitation History
1828- 1896	Construction of two stone-filled timber crib piers was completed at the mouth of the Black River (Figure 219) during this time. The east pier was originally 1,875 ft long, and the west pier was 1,004-ft long. The east pier was 20 ft wide, and the west pier ranged from 17 to 23 ft wide (Figure 220).
1897- 1908	The east and west piers were capped with concrete superstructures (Figure 220). The crest els of the piers were +8.2 ft lwd.
1901- 1915	Construction of two detached rubble-mound breakwaters (Figure 219) was completed. The east and west breakwaters were 2,300 and 2,811.5 ft long, respectively. The structures had crest els of +10.2 ft lwd and crest widths of 10 ft. Side slopes were 1V:3H on the lakeside and 1V:1.3H on the harbor side. Armor stones used were 3 tons (minimum).
1921	The west breakwater was extended to shore (Figure 219). The extension was of rubble-mound construction and originated at the shore end of the existing west breakwater extending shoreward 438.5 ft. At this point there was a 75-ft gap and then a 750-ft-long extension to the shore. The structure had a crest el of +3.9 ft lwd with a width of 5 ft (Figure 220). Armor stone was 2 tons (minimum).
1963	Construction of a 2,457-ft-long east breakwater shore arm (Figure 219) was completed at a cost of about \$2.7 million. The outer 2,323 ft was a granular-filled concrete capped cellular steel sheet-pile structure. The cells had a 35-ft diameter with a crest el of +10 ft lwd (Figure 221). Also included was a 134-ft-long rubble-mound shore connection (Figure 219). The rubble-mound portion had a crest el of +10 ft lwd and was capped with rectangular blocks (Figure 221).
1964- 1965	The lakeward 995-ft portion of the east pier was removed leaving an 880-ft-long pier, and the lakeward 280-ft portion of the east breakwater was removed resulting in a structure 2,020 ft in length (Figure 219). A 2,180-ft-long granular-filled cellular steel sheet-pile outer breakwater was constructed (Figure 219). Cell diameters were 46.15 ft, and the breakwater was capped with concrete to an el of +10 ft lwd (Figure 221). Riprap toe protection also was placed adjacent to both sides of the breakwater. This modification was model tested (Wilson, Hudson, and Housley 1963).
1977	A combination rubble-mound and steel sheet-pile dredge disposal dike was constructed and attached to the east breakwater shorearm.
1986	Recent site inspections indicated that portions of the rubble-mound stone sections of the structures show localized damage and considerable settlement. The structures are considered in fair condition, and no repairs are planned in the near future. An aerial photo of the Lorain Harbor structures is shown in Figure 222.





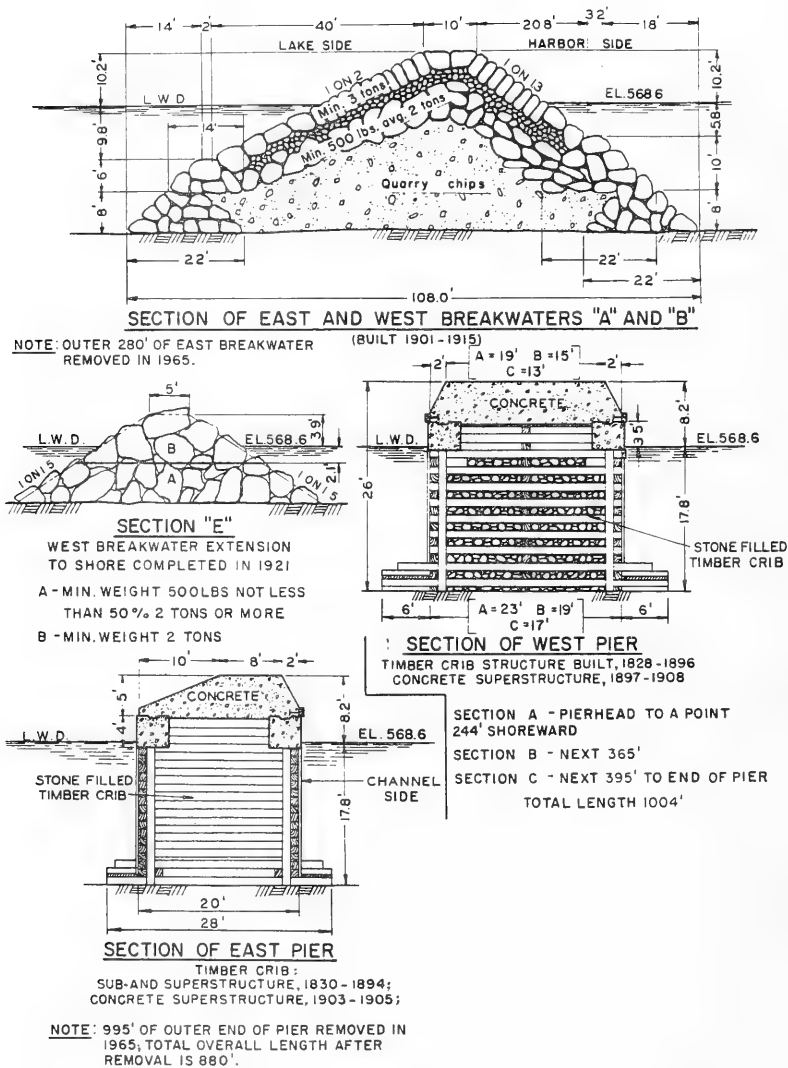
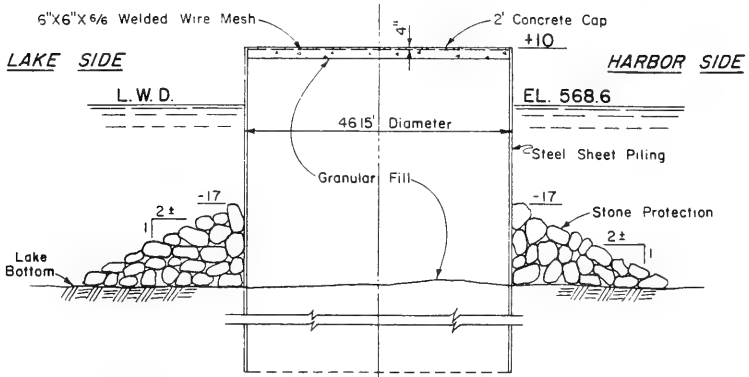
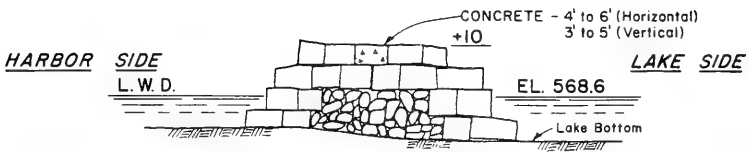


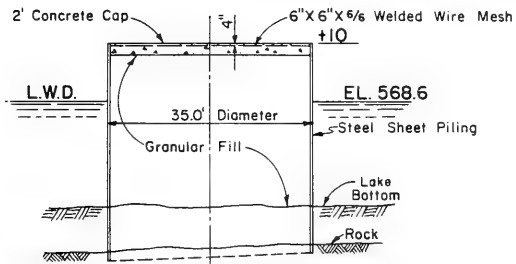
Figure 220. Typical pier and breakwater cross sections, Lorain Harbor, Ohio



**TYPICAL SECTION  
OUTER BREAKWATER**  
(BUILT 1964-1965)



**TYPICAL SECTION OF  
RUBBLE MOUND SHORE CONNECTION  
EAST BREAKWATER SHORE ARM**  
(BUILT 1963)



**TYPICAL SECTION OF CELL  
EAST BREAKWATER SHORE ARM**  
(BUILT 1963)

Figure 221. Typical breakwater cross sections, Lorain Harbor, Ohio



Figure 222. Aerial view of Lorain Harbor, Ohio

Table 84  
Rocky River Harbor East Pier  
Rocky River, Ohio

<u>Date(s)</u>	<u>Construction and Rehabilitation History</u>
1873	Construction of a 448-ft-long rubble-mound pier (Figure 223, Section B) was completed east of the mouth of the Rocky River. The crest el of the pier was +5.0 ft (Figure 224, Section B).
1941	The existing pier was rebuilt to its original design and extended an additional 452 ft lakeward (Figure 223, Section A). The pier extension was of rubble-mound construction and had a crest width of 5 ft and a crest el of +5 ft lwd (Figure 224, Section A). Side slopes were 1V:1.3H, and armor stones had a minimum weight of 2.5 tons with not less than 40 percent of 4 tons or more.
1970	A total of 260 stones was placed on the pier to repair storm damage.
1981	An inspection of the pier indicated the lakeward portion was in good condition, but the shoreward 390 ft of the pier required rehabilitation. Although no emergency existed at this time, maintenance was recommended to provide full protection to the river entrance and safer access for fishermen onto the pier. It is not known if the repairs were performed. An aerial view of the Rocky River Harbor East pier is shown in Figure 225.

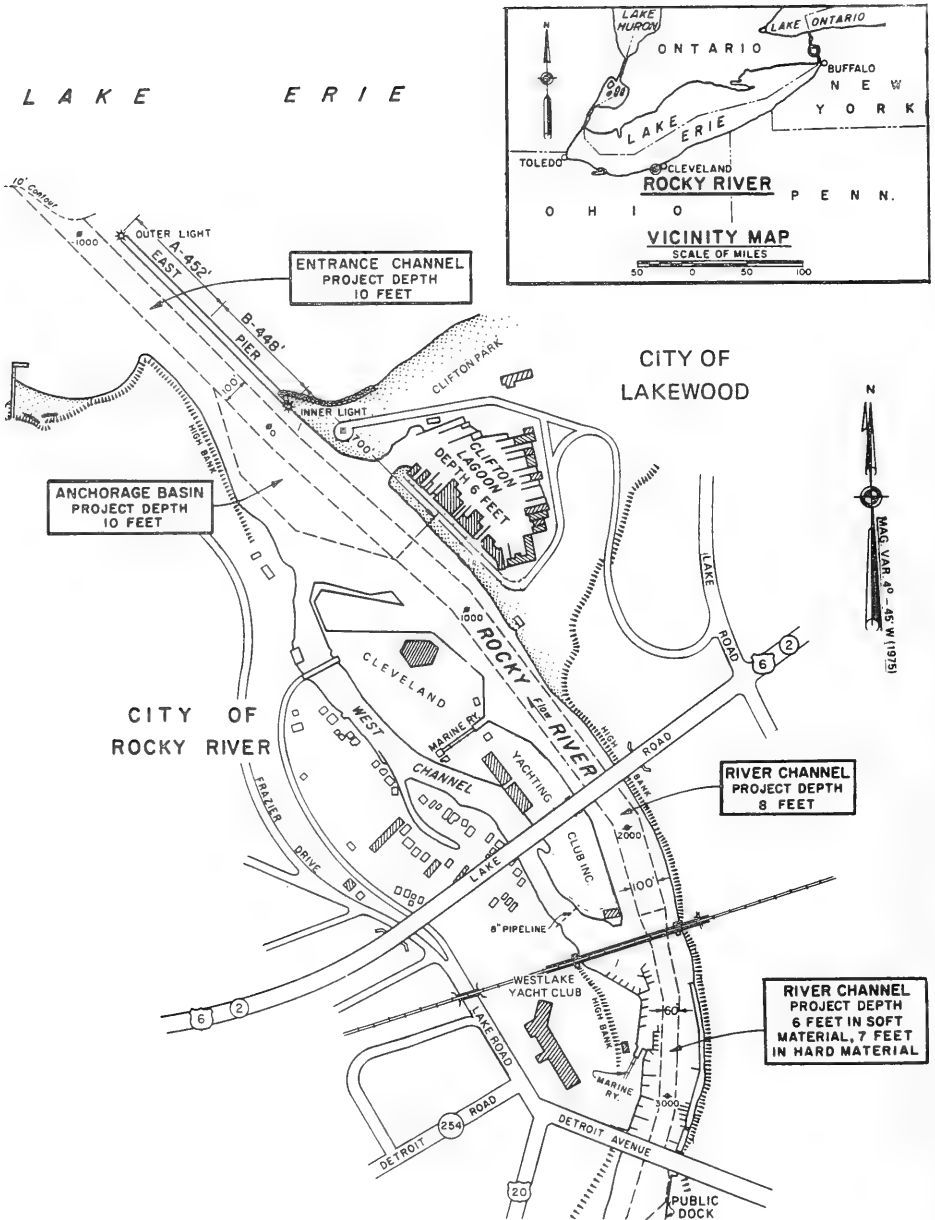
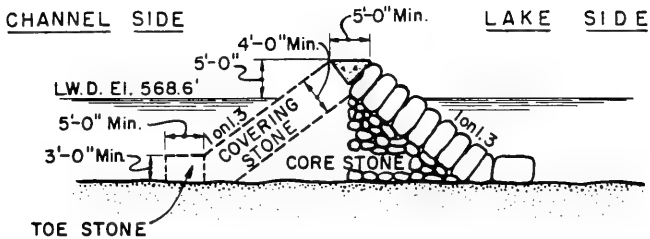


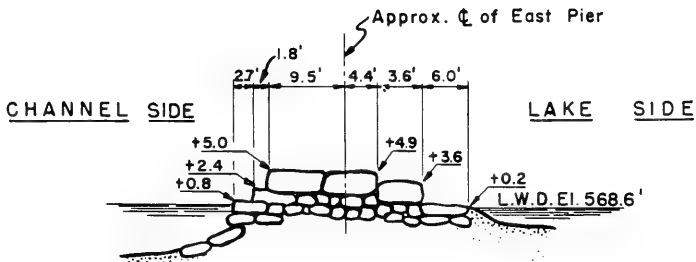
Figure 223. Rocky River Harbor, Ohio



**SECTION OF EAST PIER -A-**

(LAKEWARD 452 FT. BUILT 1941)

- Covering Stone - Minimum weight  $2\frac{1}{2}$  tons, not less than 40% 4 tons or more.
- Toe Stone - Minimum weight 6 tons.
- Core Stone - Not less than 75% 150 pounds or more, not more than 5% less than 5 pounds each.



**SECTION OF EAST PIER -B-**

(INNER 448 FT. BUILT 1873, REBUILT 1941)

Figure 224. Typical pier cross sections, Rocky River Harbor, Ohio



Figure 225. Aerial view of Rocky River Harbor, Ohio



Table 85  
Cleveland Harbor Structures  
Cleveland, Ohio

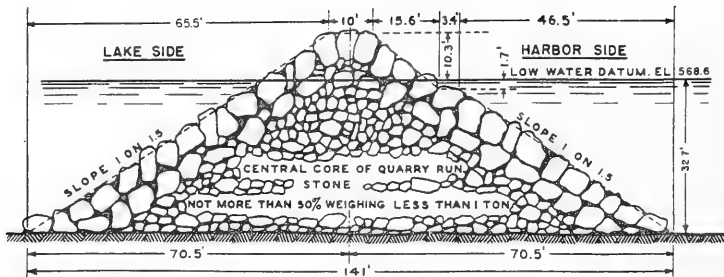
Date(s)	Construction and Rehabilitation History
1875	Construction of a 1,602-ft-long stone-filled timber crib east pier at the mouth of the Cuyahoga River (Figure 226) was completed. (Figures 226, 227, 228, and 229 illustrate structures at Cleveland Harbor.) The pier was 20 ft wide and included a concrete superstructure with a crest el of +7.3 ft lwd (Figure 227).
1876-1884	Construction of a 6,048-ft-long stone-filled timber crib west breakwater (Figure 226) was completed. The structure was 32 ft wide, and riprap stone was placed on the lakeside to an el of +5 ft lwd.
1887-1900	Construction of a 3,000-ft-long portion of the east breakwater (Figure 226, Sections X and Y) was completed. The structures were stone-filled timber cribs that were 32 ft wide.
1898-1907	A concrete superstructure was installed on the west breakwater to a crest el of +12 ft lwd.
1899-1901	Construction of a 1,440-ft-long west pier was completed (Figure 226). It was a stone-filled timber crib structure with a concrete superstructure (Figure 227) installed at an el of +6.8 ft lwd.
1903-1915	Construction of a 17,970-ft-long portion of the east breakwater was completed (Figure 226, Sections P and D). The breakwater was a rubble-mound structure with a crest el of +10.3 ft lwd and a crest width of 10 ft (Figure 227, Section P, Figure 229, Section D). Side slopes were 1V:1.5H.
1904-1909	Construction of the east and west arrowhead breakwaters was completed (Figure 226) at the main entrance. These structures were each 1,250 ft long and constructed of rubble-mound materials. They had crest widths of 10 ft and an el of +8 ft lwd (Figure 227). Side slopes of the arrowheads along the water level were 1V:1.3H. Armor stone had a minimum weight of 3 tons, with not less than 50 percent of 5 tons or more.
1917-1926	A stone superstructure was installed on portions of the east breakwater (Figure 226, Sections X and Y). The crest el of Section X (Figure 228) was +6 ft lwd. Riprap was also installed along both sides of this portion of the breakwater. The crest el of Section Y (Figure 228) was +10 ft lwd, and stone extended from the el down the lakeside of the structure to the lake bottom.
1961-1962	Rehabilitation of 1,700 ft of the east breakwater (Figures 226 and 227, Section P) was performed. Original construction methods were used in making the repairs.

(Continued)

Table 85 (Concluded)

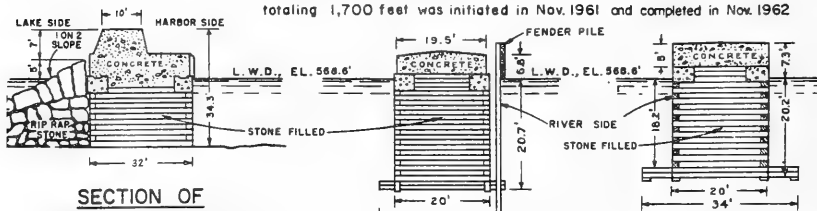
Date(s)	Construction and Rehabilitation History
1963	Rehabilitation of 1,000 ft of the protective riprap slope on the lakeside of the west breakwater (Figures 226 and 227) was performed.
1979	Portions of the west breakwater were rehabilitated (Figure 229). The concrete cap was restored to its original height, and new armor stone was installed along the lakeside of the riprap slope. The eastern portion of the east breakwater was in poor condition during a site inspection.
1980	Rehabilitation of 4,400 ft of the eastern end of the east breakwater (Figure 226, Section D) was performed using 29,700 two-ton unreinforced dolos concrete armor units. Two layers of dolosse were placed on the lakeside of the trunk and around the head using a placement density of 161 dolosse per 25 lin ft of breakwater. The slope was 1V:2H. Model tests were not conducted prior to installation of the dolosse.
1982	Repair of the head of the east breakwater following a storm in April was completed using 200 two-ton unreinforced dolosse.
1982- 1983	Model tests were conducted to determine the breakwater modifications necessary at the west (main) entrance to accommodate the passage of 1,000-ft-long ore carriers (Bottin 1983). Breakwater modifications at Edgewater Marina (adjacent to the west breakwater) for wave protection also was investigated in the model (Bottin and Acuff 1983).
1984	An inspection of the east breakwater (Figure 226, Section D) revealed 659 broken dolosse. Many of these units were broken during initial placement. A concentration of broken dolosse near the top of the slope at the head was believed to be remnants of those broken during the 1982 storm. In general, dolosse are generally confined to the upper third of the structure slope and are at about 2 percent of the total number placed.
1985	A contract was awarded to rehabilitate an additional 3,300 ft of the east breakwater (an area of Section P (Figure 226) adjacent to the dolos rehabilitation). The repairs involved placement of 9- to 20-ton armor-stone mix. Model testing was conducted prior to rehabilitation work (Markle and Dubose 1985).
1986	Repairs have been extensive at Cleveland Harbor over its lifetime (particularly to the east breakwater). Until recently the structure was repaired in a manner similar to the original construction using 3- to 8-ton stone. Consequently, maintenance on the breakwater during a 19-year period (1966-1984) involved repairs to about 12,500 lin ft of breakwater at an expenditure in excess of \$17,000,000. Since the latest rehabilitation, the structures are considered to be in good condition. Aerial photos showing the Cleveland Harbor structures are presented in Figures 230-233.





**SECTION OF EAST BREAKWATER -P-**  
(BUILT 1903-1915)

Rehabilitation of breakwater in 5 sections totaling 1,700 feet was initiated in Nov. 1961 and completed in Nov. 1962



**SECTION OF WEST BREAKWATER**

(BUILT 1876-1884)  
CONCRETE SUPER-STRUCTURE  
BUILT 1898-1907

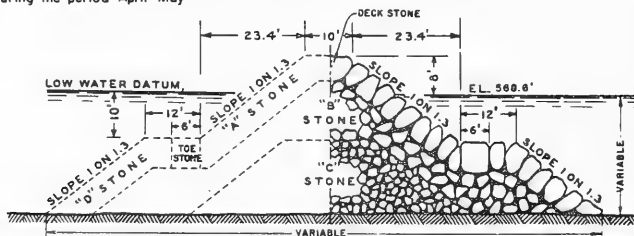
Rehabilitation of protective riprap slope on lake side, in sections totaling 1000' was done during the period April-May 1963.

**SECTION OF WEST PIER**

(BUILT: SUB-STRUCTURE 1899  
SUPER-STRUCTURE 1901)

**SECTION OF EAST PIER**

(BUILT 1875)

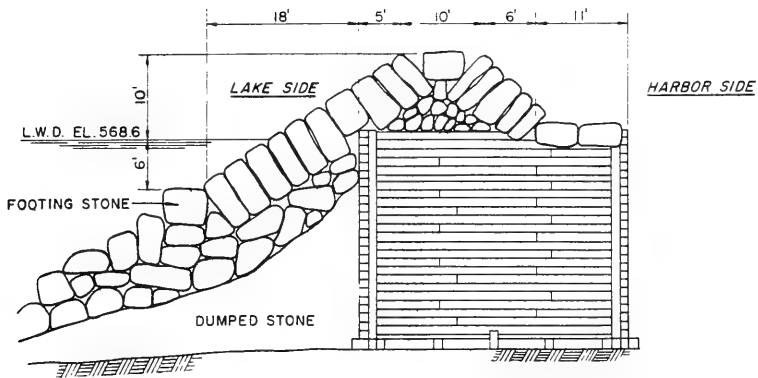


**SECTION OF ARROWHEAD BREAKWATERS**

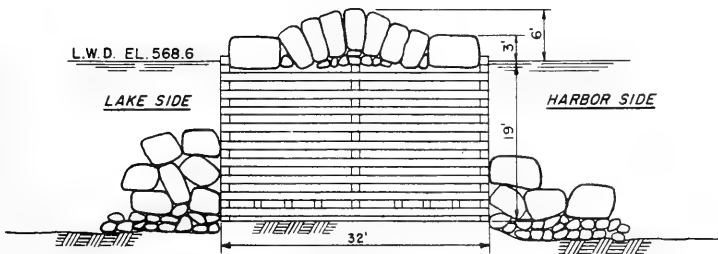
(BUILT 1904-1909)

- DECK STONE - MIN. WEIGHT 5 TONS.
- A STONE - MIN. WEIGHT 3 TONS, NOT LESS THAN 50% 5 TONS OR MORE.
- B STONE - MIN. WEIGHT 100 LBS.
- C STONE - NOT LESS THAN 3% 75 LBS. OR MORE, NOT MORE THAN 3% LESS THAN 1 LB.
- D STONE - MIN. WEIGHT 3 TONS.
- TOE STONE - MIN. WEIGHT 7 TONS.

Figure 227. Typical pier and breakwater cross sections, Cleveland Harbor, Ohio



SECTION "Y"  
**EAST BREAKWATER**  
 (BUILT 1887-1900)  
 (STONE SUPERSTRUCTURE BUILT 1917-1926)



SECTION "X"  
**EAST BREAKWATER**  
 (BUILT 1887-1900)  
 (STONE SUPERSTRUCTURE BUILT 1917-1926)

Figure 228. Typical east breakwater cross sections,  
 Cleveland Harbor, Ohio





Figure 230. Aerial view of Cleveland Harbor, Ohio

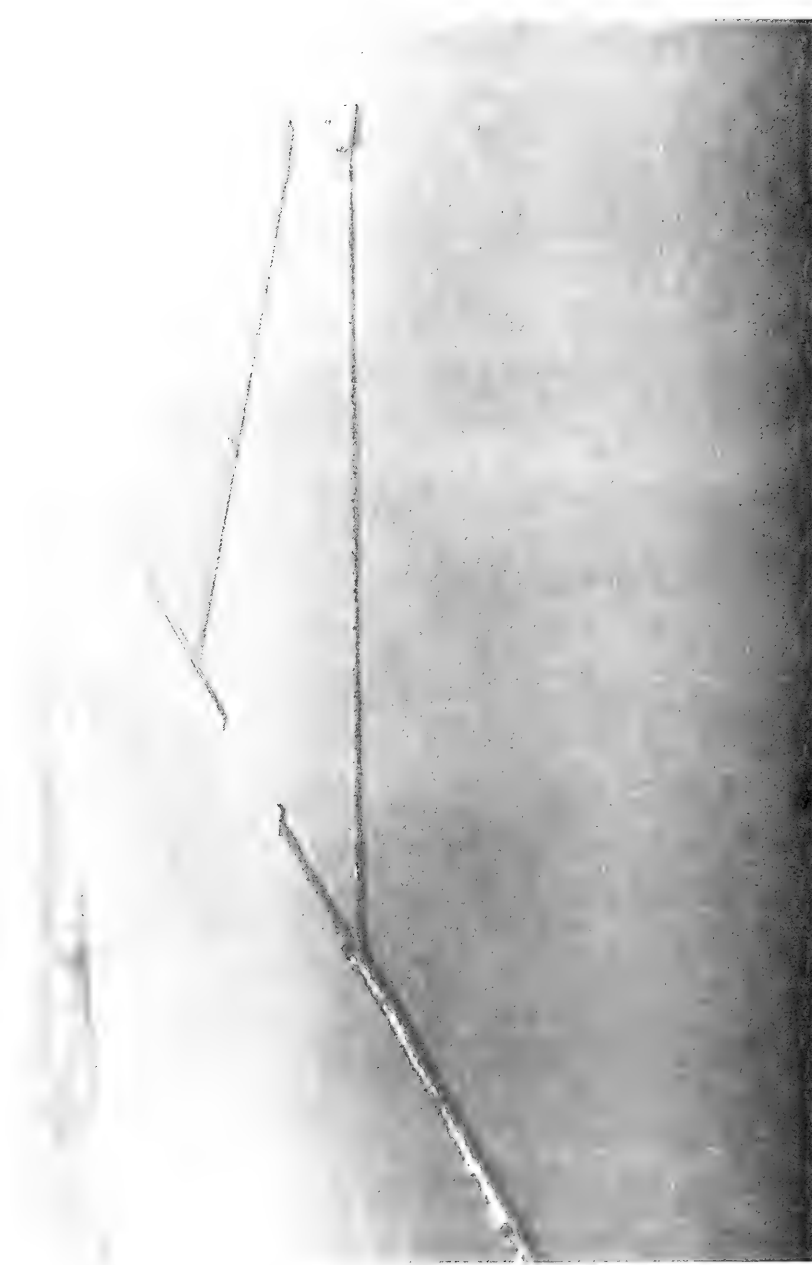


Figure 231. Aerial view of main entrance to Cleveland Harbor, Ohio



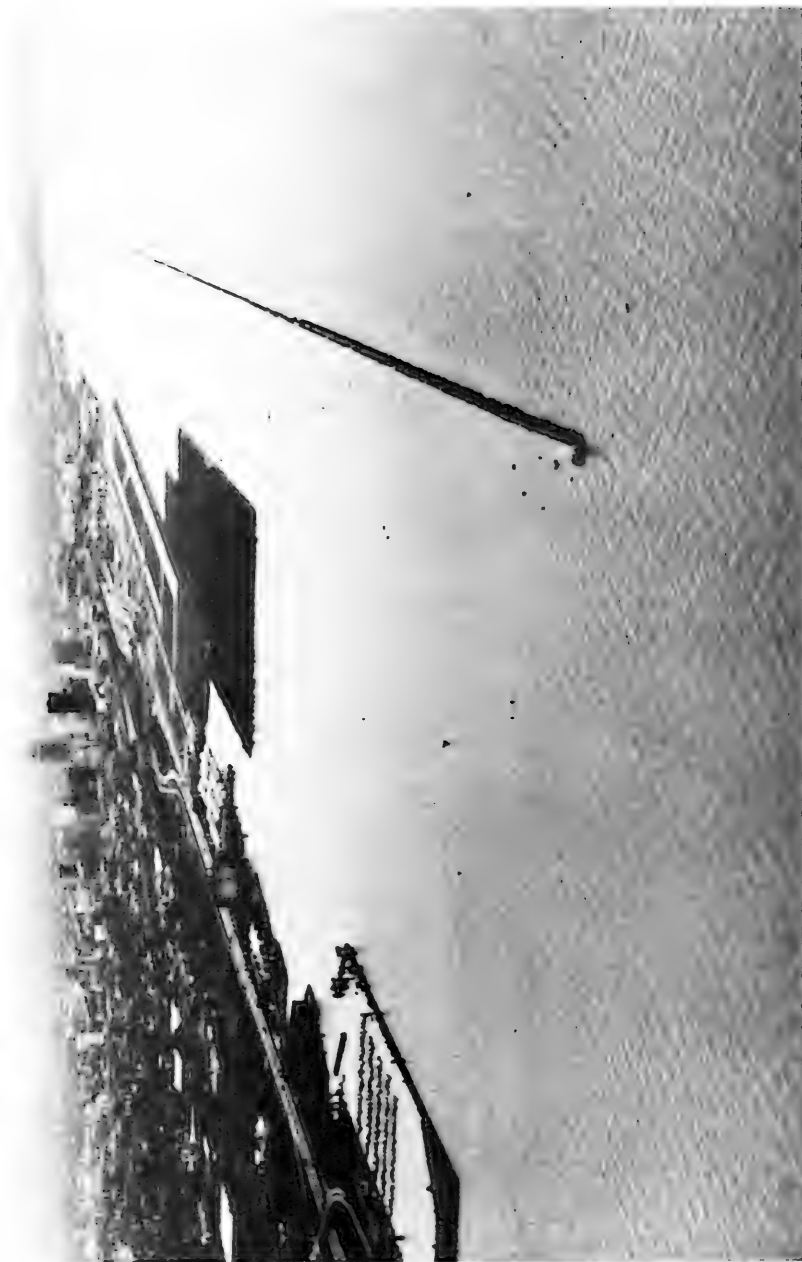


Figure 232. Aerial view of Cleveland Harbor, Ohio looking west



Figure 233. Aerial view of rehabilitated east breakwater, Cleveland Harbor, Ohio

Table 86  
Fairport Harbor Structures  
Fairport, Ohio

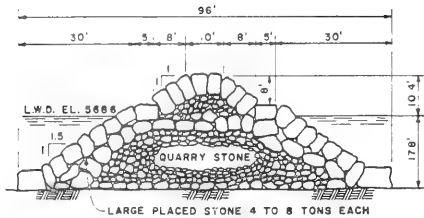
<u>Date(s)</u>	<u>Construction and Rehabilitation History</u>
1868	Construction of the east pier (Figure 234) was completed. The pier was a stone-filled timber crib structure that was 20 ft wide (Figure 235, Section E).
1905	The east pier was capped with a concrete and stone superstructure (Figure 235, Section E). Construction of the shoreward 2,325-ft-long portion of the west breakwater (Figure 234, Sections H and J) was completed. The innermost 1,500-ft portion of the breakwater was of rubble-mound construction (Figure 236, Section H). It had a crest el of +9.9 ft lwd with a width of 10 ft. Side slopes were 1V:2H on the lakeside and 1V:1.3H on the channel side. The lakeward portion of the breakwater was constructed with stone-filled timber cribs (Figure 236, Section J) that were 26 ft wide.
1911	The west breakwater was extended by 1,053 ft (Figure 234, Section A). The extension was of rubble-mound construction and had an el of +10.4 ft lwd with a crest width of 10 ft (Figure 235, Section A). Side slopes were 1V:1.5H, and the armor stones used ranged from 4 to 8 tons each.
1925	Stone was placed over the cap and on the lakeside of the timber crib portion of the west breakwater (Figures 234 and 236, Section J). The stone was placed at an el of +9.9 ft lwd with a crest width of 10 ft and side slopes of 1V:2H.
1932	Construction of a 6,750-ft-long rubble-mound detached east breakwater (Figure 234, Section B) was completed. The breakwater had a crest el of +8.2 ft lwd and a width of 10 ft (Figure 235, Section B). Side slopes were 1V:1.5H and had a minimum weight of 3 tons.
1935	A 500-ft-long extension of the west breakwater (Figure 234, Section F) was completed. The extension consisted of a sand-filled cellular steel sheet-pile structure (Figure 235, Section F). The cells were 30 ft in diameter and capped with concrete at an el of +8.4 ft lwd. Riprap was placed on the channel side.
1939	Construction of a 500-ft-long west pier (Figure 234, Section D) was completed. The pier consisted of sand-filled cellular steel sheet-pile structures (Figure 235, Section D). The cell diameters were 34 ft, and they were capped with concrete at an el of +7.9 ft lwd.
1946	Because of settlement of the sand fill, one of the cells in the west breakwater extension was repaired by using cut stone to replace the concrete cap.

(Continued)

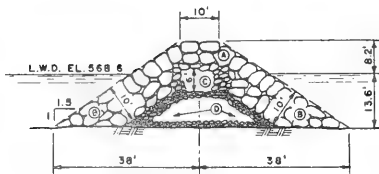
Table 86 (Concluded)

Date(s)	Construction and Rehabilitation History
1949	Because of deterioration of the inner portion of the east pier (Figure 234, Section C) was removed and replaced with steel sheetpiling with a sand fill (Figure 235, Section C). The el of the pier was +8.2 ft lwd.
1972	Settlement of three cell caps in the west breakwater extension led to their replacement with cut stone.
1979	An inspection of the piers and the west breakwater indicated that they were in good to very good condition. Slight settlement of Section J (Figure 234) was noted, however.
1984	Normal maintenance repair of the west breakwater was performed for a cost of \$308,000.
1986	The piers and the west breakwater are considered to be in good condition presently. The east breakwater is in a state of deterioration throughout its entire length. At several places the slope stone has disintegrated and settled; and the core stone has washed out, leaving large areas of the structure only slightly above lwd. Since proposed industrial expansion in the lee of the east breakwater never materialized, the structure has not been maintained. An aerial view of the Fairport Harbor structures at the entrance is shown in Figure 237.



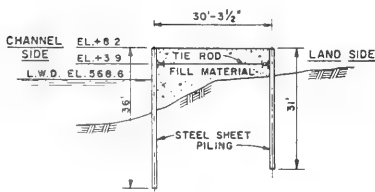


**SECTION OF WEST BREAKWATER-A**  
(BUILT IN 1911)

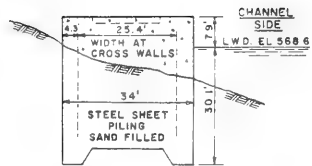


**SECTION OF EAST BREAKWATER-B**  
(BUILT IN 1932)

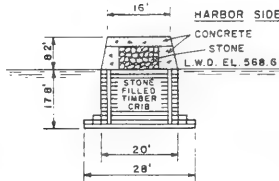
- Ⓐ COVER STONE NOT MORE THAN 10% BY WEIGHT LESS THAN 3 TONS.
- Ⓑ COVER STONE, MINIMUM WEIGHT 3 TONS.
- Ⓒ CORE STONE, MINIMUM WEIGHT 500 LBS., 50% BY WEIGHT ONE TON OR OVER.
- Ⓓ CORE STONE, QUARRY RUN.



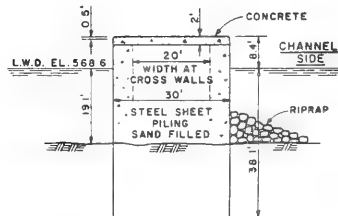
**SECTION OF EAST PIER-C**  
(BUILT IN 1949)



**SECTION OF WEST PIER-D**  
(BUILT IN 1939)

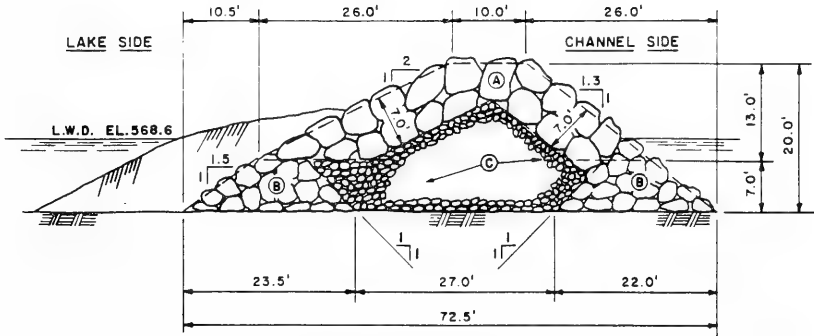


**SECTION OF EAST PIER-E**  
(SUB-STRUCTURE BUILT IN 1868  
SUPER STRUCTURE BUILT IN 1905)



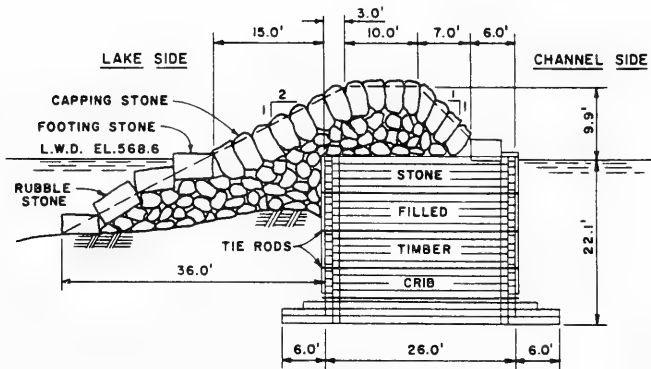
**SECTION OF BREAKWATER  
EXTENSION-F**  
(BUILT IN 1935)

Figure 235. Typical pier and breakwater cross sections, Fairport Harbor, Ohio



**SECTION OF  
WEST BREAKWATER-H**  
(BUILT IN 1905)

- (A) COVER STONE—SIZE=19 TONS PER LIN.FT.
- (B) QUARRY STONE—SIZE= 4 TONS PER LIN.FT.
- (C) SMALL RIPRAP STONE—SIZE=18 TONS PER LIN.FT.



**SECTION OF  
WEST BREAKWATER-J**  
(BUILT 1905)  
(REPAIRED 1925)

Figure 236. Typical west breakwater cross sections,  
Fairport Harbor, Ohio



Figure 237. Aerial view of Fairport Harbor, Ohio



Table 87

Geneva-on-the-Lake StructureGeneva-on-the Lake, Ohio

<u>Date(s)</u>	<u>Construction and Rehabilitation History</u>
1978	Construction of three offshore experimental breakwaters was completed as part of a shoreline erosion control demonstration program. These were low-cost shore erosion protection devices which might be feasible for use by private property owners. Three structure designs (i.e., sta-pod, gabion, and z-wall) were constructed for a cost of \$167,200. The structures are being monitored, and no maintenance will be performed.
1986	Construction of a small-boat harbor is proposed adjacent to the state park. Two breakwaters totaling about 1,450 ft in length are proposed for harbor protection (Figure 238). Construction has not been initiated. The project was model tested (Bottin 1982b).

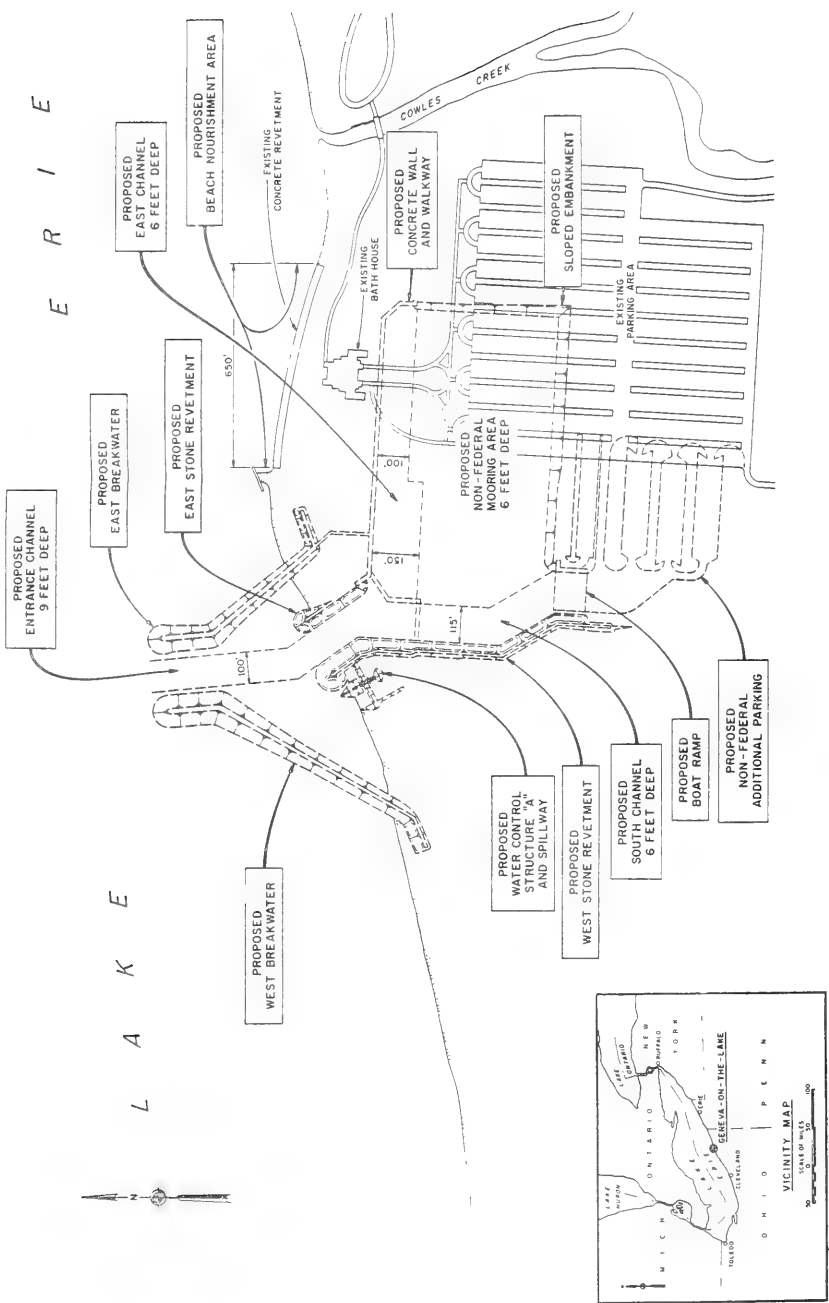


Figure 238. Geneva-on-the-Lake, Ohio

Table 88

Ashtabula Harbor BreakwatersAshtabula, Ohio

Date(s)	Construction and Rehabilitation History
1897- 1924	Construction of a 6,600-ft-long rubble-mound west breakwater (Figure 239, Sections N and O) was performed during this time. The breakwater had a +10.3 ft crest el lwd and a 10-ft-wide crest (Figure 240, Sections N and O). Side slopes were 1V:1.5H on the lakeside and 1V:1.3H on the harbor side. Armor stone was greater than 3 tons in weight. A 430-ft-long portion of the rubble-mound breakwater was built adjacent to an existing timber crib structure (Figure 239).
1901- 1909	The 1,298-ft-long eastern portion of the inner breakwater (Figure 239, Section S) was constructed during this period. The breakwater was a rubble-mound structure with a crest width of 10 ft and an el of +10.3 ft lwd (Figure 241, Section S). Side slopes on the lakeside were 1V:2.5H and 1V:0.75H on the shoreward side. Cover stone with a 3-ft thickness was used.
1912- 1915	Construction of a 3,692-ft-long rubble-mound east breakwater (Figure 239, Section P) was completed during this period. The breakwater cross-section was similar to that of the west breakwater built from 1897-1924 (Figure 240, Section P).
1934- 1936	Lakeward extensions of the east and west breakwaters (Figure 239, Sections R and Q) were completed. These were rubble-mound extensions with crest els of +10 ft lwd and crest widths of 10 ft (Figure 240, Sections Q and R). Side slopes were 1V:1.3H. Armor stone had a minimum weight of 3 tons with not less than 50 percent of 5 tons or more.
1977	A 100-ft-long, rubble-mound westward extension of the inner breakwater was completed. The extended head section (Figure 241, Section S) had a crest width of 27 ft with a +10 ft lwd el. Side slopes were 1V:1.5H, and cover stones ranged from 3.25 (min) to 7.25 tons (max).
1981- 1982	Major rehabilitation of the east and west breakwater trunks (Figure 239) and the western head of the east breakwater was completed. The east breakwater head rehabilitation (Figure 242) involved a 51-ft-wide crest width with an el of +10.3 ft lwd and side slopes of 1V:2H. Armor stone ranging from 9.5 to 19 tons was used. The trunk section of the east breakwater was repaired by the addition of armor stone ranging from 3.7 to 15 tons (Figure 241). The crest was 13 ft wide and had an el of +10.3 ft lwd. The west breakwater rehabilitation (Figure 242) consisted of armor stone (7 to 19 tons) placement on the lakeside to an el of +10.3 ft and a width of 17 ft. Side slopes used on the trunk sections were 1V:1.5H.

(Continued)

Table 88 (Concluded)

Date(s)	Construction and Rehabilitation History
1985	The breakwaters are presently considered to be in good condition; however, some sections of the east breakwater exhibit minor localized damage. An aerial view of the Ashtabula Harbor breakwaters is shown in Figure 243.

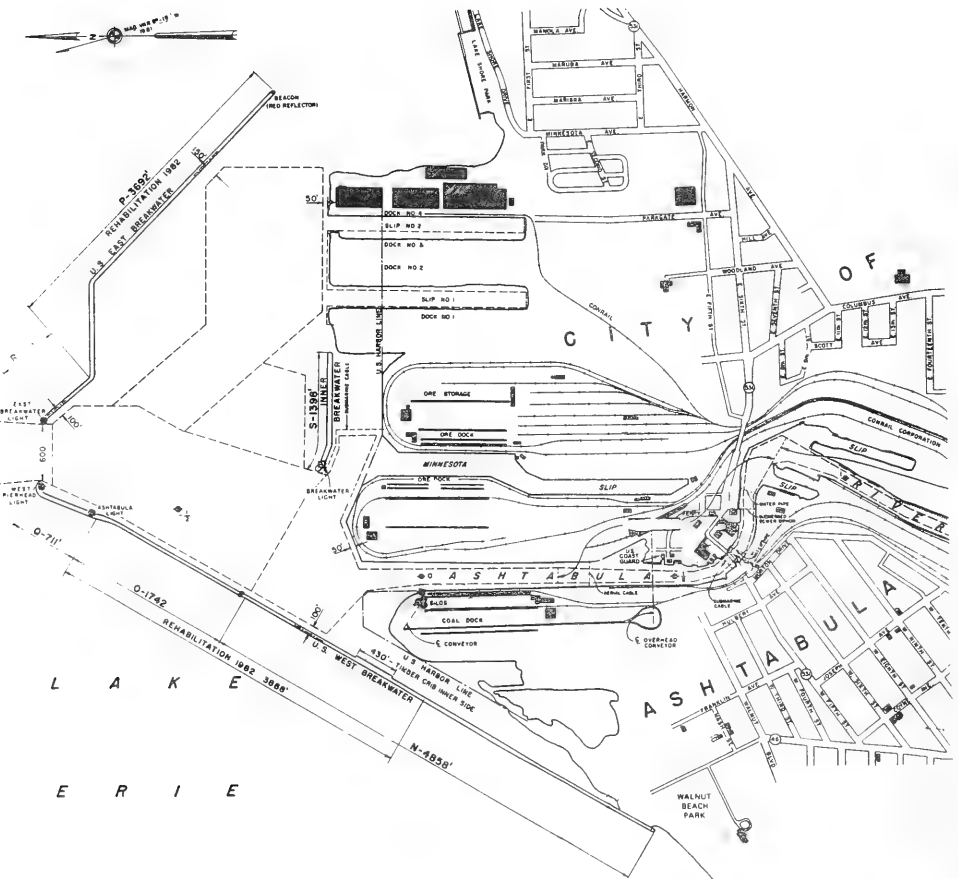
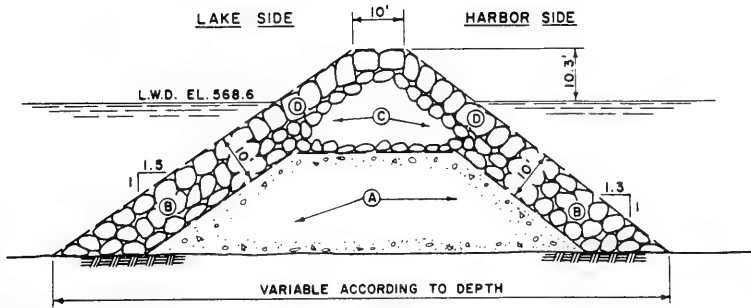


Figure 239. Ashtabula Harbor, Ohio

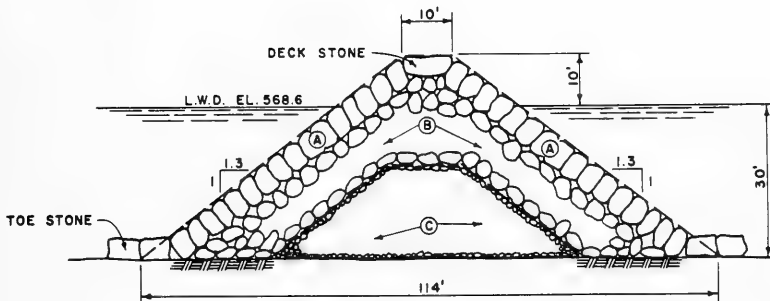


**SECTION OF EAST AND WEST  
BREAKWATERS-N-O-P**

**TIMBER CRIB IN SECTION-N**

(EAST BREAKWATER BUILT 1912-1915  
WEST BREAKWATER BUILT 1897-1924)

- (A) QUARRY CHIPS.
- (B) QUARRY RUN NOT LESS THAN 3 TONS.
- (C) QUARRY RUN BETWEEN 500 LBS. AND 3 TONS.
- (D) CAPPING STONE GREATER THAN 3 TONS.

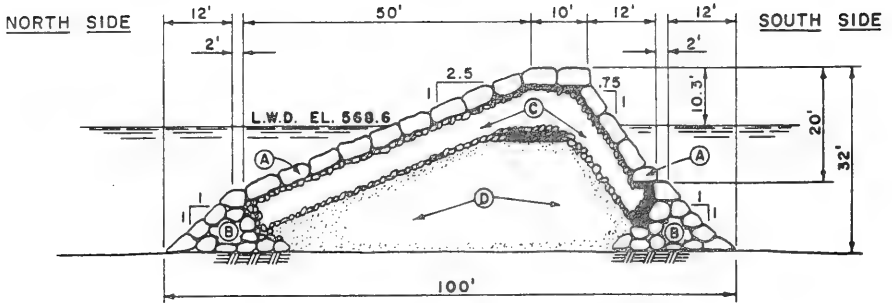


**SECTION OF BREAKWATERS-Q-R**

(BUILT 1934-1936)

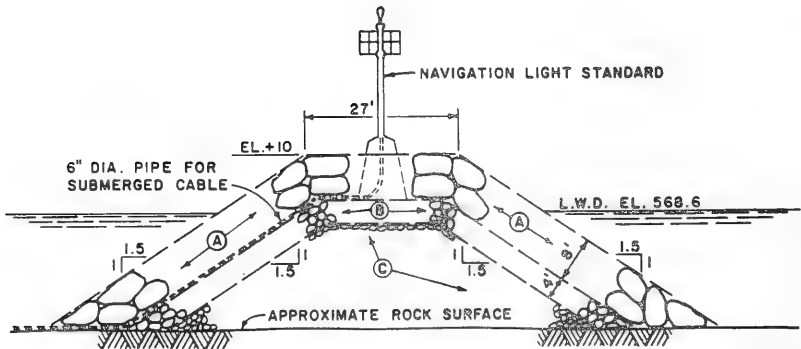
- DECK STONE: MINIMUM WEIGHT 5 TONS. MINIMUM THICKNESS 30 INCHES.
- (A) STONE: MINIMUM WEIGHT 3 TONS. NOT LESS THAN 50% 5 TONS OR MORE. MINIMUM THICKNESS 24 INCHES.
- (B) STONE: MINIMUM WEIGHT 150 LBS.
- (C) CORE STONE: NOT LESS THAN 35% 75 LBS. NOT MORE THAN 3% WEIGHING LESS THAN 1 LB. EACH.
- TOE STONE: MINIMUM WEIGHT 7 TONS. MINIMUM THICKNESS 42 INCHES.

Figure 240. Typical east and west breakwater cross sections, Ashtabula Harbor, Ohio



**ORIGINAL SECTION OF  
INNER BREAKWATER-S  
(BUILT 1901-1909)**

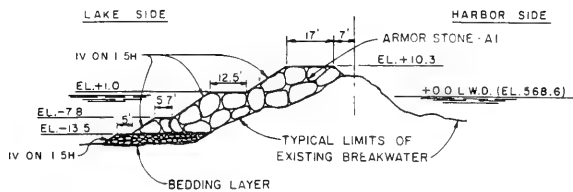
- (A) PLACED COVER STONE 3 FT. THICK
- (B) LARGE RIPRAP.
- (C) SMALL RIPRAP.
- (D) LAKE SAND.



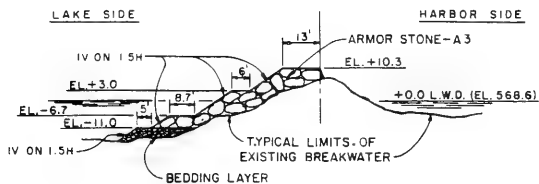
**SECTION OF INNER BREAKWATER-S  
(WEST END 100'±-BUILT 1977)**

- (A) COVER STONE: MINIMUM 3.25 TONS-MAXIMUM 7.25 TONS.
- (B) UNDERLAYER STONE: 325 LBS. TO 1500 LBS., AVERAGE 500 LBS. TO 1200 LBS.
- (C) CORE STONE: 1 LB. TO 75 LBS., AVERAGE 15 LBS. TO 50 LBS.

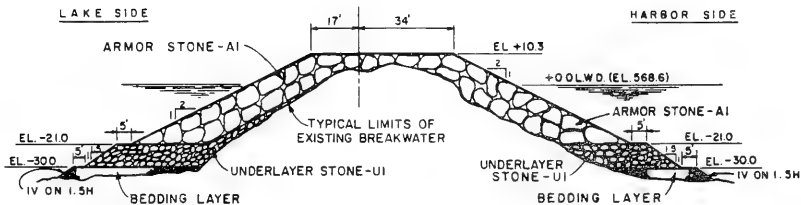
Figure 241. Typical inner breakwater cross sections, Ashtabula Harbor, Ohio



**SECTION OF WEST BREAKWATER**  
REHABILITATION IN 1981



**SECTION OF EAST BREAKWATER**  
REHABILITATION IN 1981



**HEAD SECTION OF EAST BREAKWATER**  
REHABILITATION IN 1981

BREAKWATER	STATIONS REHABILITATED	ARMOR TYPE	ARMOR SIZE (TONS)	UNDERLAYER SIZE (UI) / (TONS)	BEDDING SIZE (LBS)	SECTION
WEST	20+50 TO 39+00	A1	8.5-19.0	0.5-2.0	CHIPS TO 200	O
BREAKWATER	7+00 TO 20+50	A2	7.0-15.0	0.5-2.0	CHIPS TO 200	N
EAST	6+50 TO 24+00	A2	7.0-15.0	0.5-2.0	CHIPS TO 200	P
BREAKWATER	24+00 TO 43+50	A3	3.7-8.3	-	CHIPS TO 200	P

Figure 242. Typical breakwater cross sections, Ashtabula Harbor, Ohio



Figure 243. Aerial view of Ashtabula Harbor, Ohio



Table 89

Lakeshore Park BreakwatersLakeshore Park, Ohio

<u>Date(s)</u>	<u>Construction and Rehabilitation History</u>
1983	Construction of three offshore detached breakwaters, 125 ft long each, was completed (Figure 244) for shoreline protection. The breakwaters were rubble-mound structures with 9.5-ft-wide crests and els ranging from +7.5 to +8.5 ft lwd (Figure 244). Side slopes were 1V:2H on the lakesides and 1V:1.5H on the harbor sides. Armor stone ranged from 1.5 to 3 tons.
1986	The breakwaters presently are considered to be in good condition, and there are no records of maintenance repair. An aerial photo of the Lakeshore Park breakwaters is shown in Figure 245.





Figure 245. Aerial view of Lakeshore Park, Ohio

Table 90

Conneaut Harbor StructuresConneaut, Ohio

Date(s)	Construction and Rehabilitation History
1894	Construction of the east and west piers (Figure 246) was completed. The piers were constructed of stone-filled timber cribs. (Figures 246, 247, 248, and 249 illustrate structures at Conneaut Harbor.) The east pier was 18 ft wide (Figure 247), and the west pier was 24 ft wide (Figure 249).
1905- 1907	The east and west piers were capped with concrete superstructures during this period. The east pier had a crest el of +8.3 ft lwd (Figure 247), and the west pier superstructure was installed at an el of about +6.1 ft lwd (Figure 249). The Corps of Engineers presently maintains only the lakeward 300-ft-long section of the west pier. A 1,054-ft-long portion of the east breakwater (Figure 246, Section C) also was constructed during this time. The breakwater was a 23-ft wide stone-filled timber crib. A concrete superstructure with a crest el of +10.3 ft lwd was included along with a rubble slope on the lakeside (Figure 247, Section C).
1911- 1912	An 810-ft-long rubble-mound shoreward extension of the east breakwater (Figure 246, Section A) was completed. The extension had a crest el of +10 ft lwd and a crest width of 10 ft (Figure 247, Section A). Side slopes on the lakeside were 1V:1.5H, and 1V:1.3H on the harbor side. Armor stones greater than 3 tons each were used in construction.
1912- 1917	A 3,403-ft-long rubble-mound west breakwater (Figure 246, Sections A and I) was constructed during this time. Breakwater cross sections were similar to those used for the east breakwater extension built during 1911-1912 (Figure 247, Section A, and Figure 248, Section I).
1916- 1923	Construction of an 886-ft-long rubble-mound lakeward extension of the east breakwater (Figure 246, Section B) was completed during this time. The structure cross section was similar to the shoreward extension of the east breakwater completed during 1911-1912 (Figure 247, Section B).
1934- 1936	Construction of a 935-ft-long rubble-mound lakeward extension of the east breakwater (Figure 246, Section G); an 865-ft-long rubble-mound lakeward extension of the west breakwater (Figure 246, Section F); and a 1,670-ft-long rubble-mound shore arm of the west breakwater (Figure 246, Section H) was completed. The lakeward extensions had 10-ft crest widths and crest els of +10 ft lwd (Figure 248, Sections F and G). Side slopes were 1V:1.3H, and armor stone had a minimum weight of 3 tons with not less than 50 percent of 5 tons or more.

(Continued)

Table 90 (Concluded)

Date(s)	Construction and Rehabilitation History
	The west breakwater shore arm had a crest el of +8 ft lwd and a width of 10 ft and 1-V:1.3-H side slopes (Figure 248, Section H). Armor stone sizes were the same as those on the lakeward breakwater extensions.
1941-1954	Rehabilitation of a 1,251-ft-long portion of the west breakwater (Figure 246, Section I) was performed. The structure was built up with additional stone to a crest el of +10 ft lwd and a crest width of 8 ft (Figure 248, Section I). Side slopes of 1V:1.3H were used, and armor stone with a minimum weight of 3 tons and not less than 50 percent of 5 tons or more was placed.
1954-1960	A 1,552-ft-long portion of the west breakwater trunk was rehabilitated by the installation of additional stone to its original design (Figures 246 and 247, Section A).
1963-1964	Rehabilitation of a 600-ft-long portion of the west breakwater (Figures 246 and 247, Section A) and an 800-ft-long portion of the east breakwater (Figures 246 and 247, Sections B and C) was completed. The rubble-mound portions of the breakwaters were repaired by the installation of additional stone to original design specifications.
1965	A 1,187-ft-long cellular steel sheet-pile shoreward east breakwater extension (Figure 246, Sections J and K) was constructed. The cells were granular filled (Figure 249, Sections J and K) and had diameters of about 30.2 (Section J) and 20.7 ft (Section K). They were capped with concrete at an el of +10 ft lwd. Model testing was conducted prior to the construction of this extension (Hudson and Wilson 1963).
1983	Maintenance repair to the west breakwater was performed for a cost of about \$310,000.
1986	The structures are presently considered to be in fair condition. The concrete cap in the midsection of the east breakwater (Figures 246 and 247, Section C), particularly, is in need of repair. An aerial view of the Conneaut Harbor structures is shown in Figure 250.

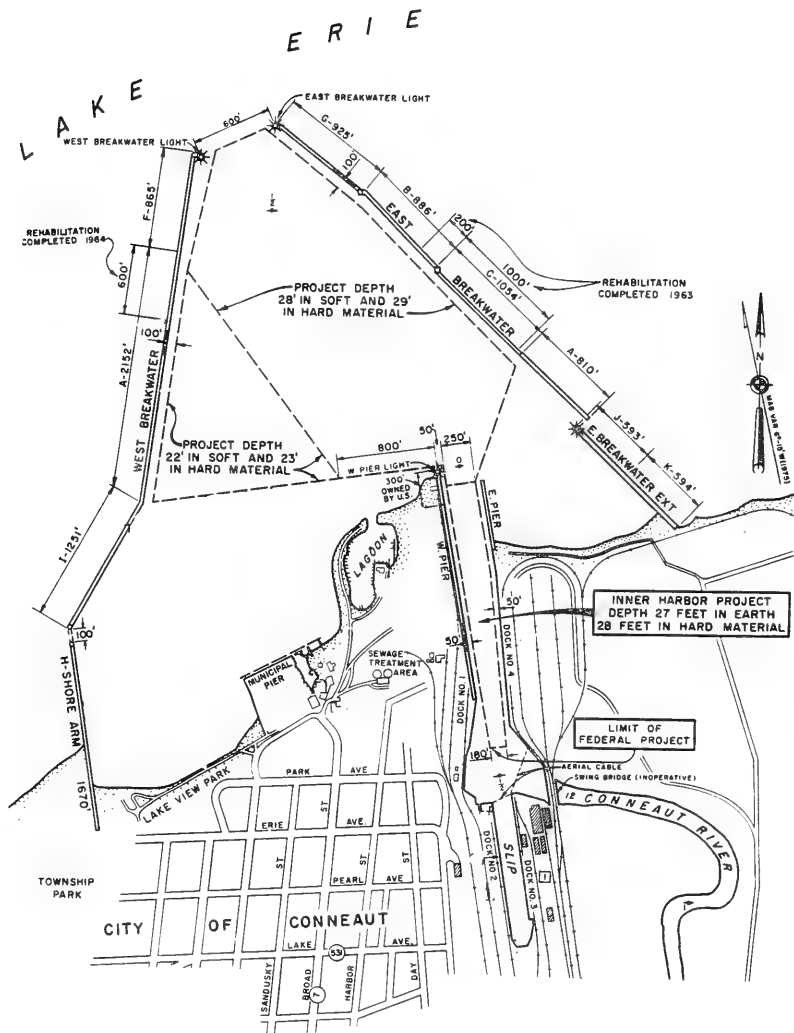
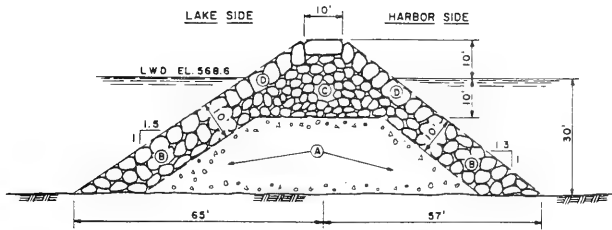


Figure 246. Conneaut Harbor, Ohio



**SECTION OF EAST AND WEST  
BREAKWATERS-A-B**

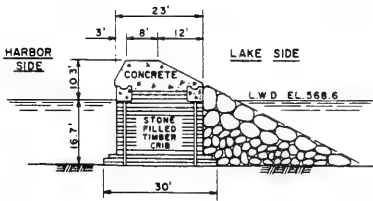
**EAST BREAKWATER**

"A" SECTION BUILT 1911-1912  
 "B" SECTION BUILT 1916-1923  
 REHABILITATION OF 200' OF "B" SECTION INITIATED  
 IN MAY 1963 AND COMPLETED IN JUNE 1964.

**WEST BREAKWATER**

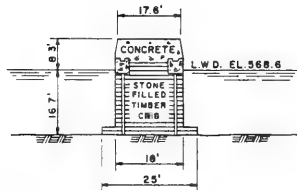
"A" SECTION BUILT 1912-1917  
 1,532' REBUILT 1954-1960  
 REHABILITATION OF 600' INITIATED IN  
 MAY 1963 AND COMPLETED IN JUNE 1964

- (A) QUARRY CHIPS.
- (B) QUARRY RUN NOT LESS THAN 3 TONS.
- (C) QUARRY RUN BETWEEN 500 LBS. AND 3 TONS.
- (D) CAPPING STONE GREATER THAN 3 TONS.



**SECTION OF  
EAST BREAKWATER-C**

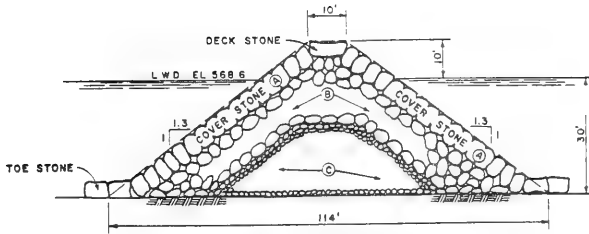
(BUILT-1905-1907)  
 REHABILITATION OF 1000 FEET INITIATED IN APRIL  
 1963 AND COMPLETED IN OCTOBER 1963.



**SECTION OF EAST PIER**

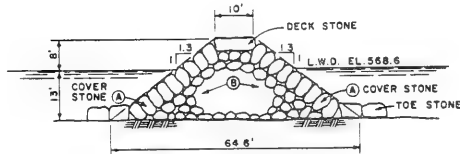
(BUILT 1894, 1907)

Figure 247. Typical structure cross sections,  
Conneaut Harbor, Ohio

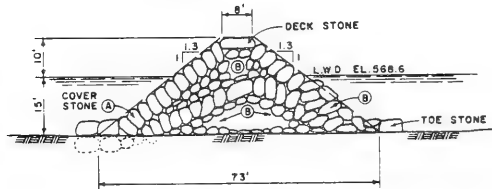


**SECTION OF EAST AND WEST  
BREAKWATERS-F-G**

**WEST BREAKWATER**  
(1" F" SECTION BUILT 1934-1936)  
**EAST BREAKWATER**  
(1" G" SECTION BUILT 1934-1936)



**SECTION OF SHORE ARM  
BREAKWATER-H**  
(BUILT 1934-1935)



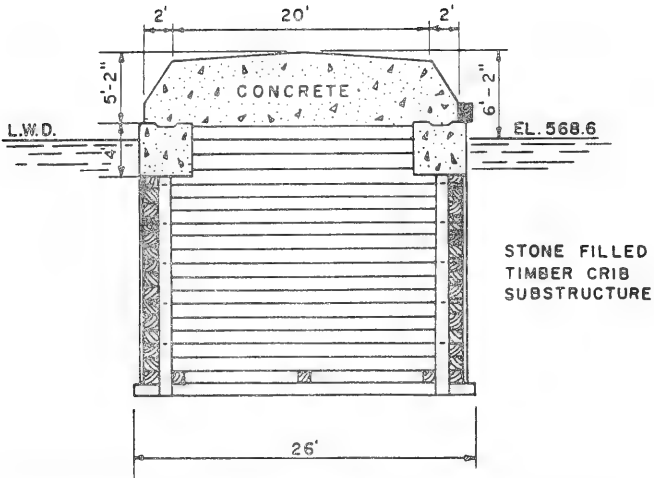
**SECTION OF  
WEST BREAKWATER-I**  
(BUILT 1912-1917  
REBUILT 1941-1954)

**SECTIONS-F-G-H-I**

- DECK STONE: MINIMUM WEIGHT 5 TONS. MINIMUM THICKNESS 30 INCHES.  
 (A) STONE: MINIMUM WEIGHT 3 TONS. NOT LESS THAN 50% 5 TONS OR MORE. MINIMUM THICKNESS 24 INCHES.  
 (B) STONE: MINIMUM WEIGHT 150 LBS.  
 (C) CORE STONE: NOT LESS THAN 35% 75 LBS. NOT MORE THAN 3% WEIGHING LESS THAN 1 LB. EACH.  
 TOE STONE: MINIMUM WEIGHT 7 TONS. MINIMUM THICKNESS 42 INCHES.

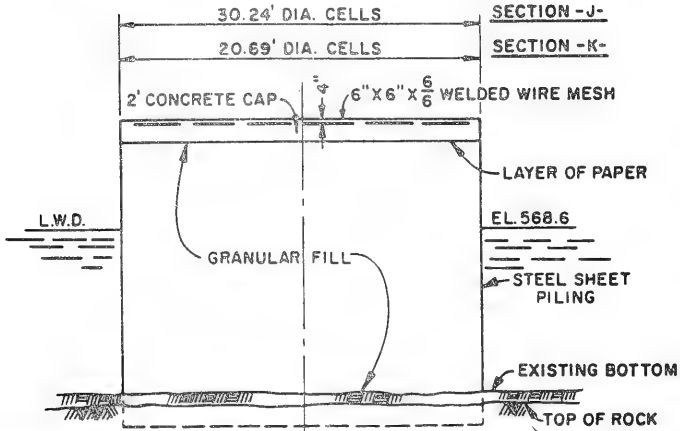
Figure 248. Typical breakwater cross sections, Conneaut Harbor, Ohio





**SECTION OF OUTER 300 FEET OF WEST PIER**

(OWNED BY U. S. GOVERNMENT)  
 (BUILT 1894 RECONSTRUCTED 1906)



**SECTIONS OF EAST BREAKWATER EXTENSION**

(BUILT 1965)

Figure 249. Typical pier and breakwater cross sections,  
 Conneaut Harbor, Ohio



Figure 250. Aerial view of Conneaut Harbor, Ohio

Table 91

Presque Isle Breakwaters  
Presque Island Peninsula, Pennsylvania

<u>Date(s)</u>	<u>Construction and Rehabilitation History</u>
1978	Construction of three detached, offshore, rubble-mound, experimental, breakwaters (Figure 251) was completed for beach erosion control. The breakwaters were each 125 ft long and had crest els of +6.0 ft lwd and widths of 6 ft. Side slopes were 1V:2H, and armor stone ranged from 1.5 to 3.5 tons (Figure 251).
1986	There are no records of maintenance repairs to the breakwaters since construction, and they are considered to be in good condition. An aerial view of the Presque Isle experimental breakwaters is shown in Figure 252. A proposal for construction of a series of 58 offshore breakwaters along the Presque Isle Peninsula is being considered. Model tests of a representative portion of the peninsula and some of the breakwaters were conducted (Seabergh 1983).

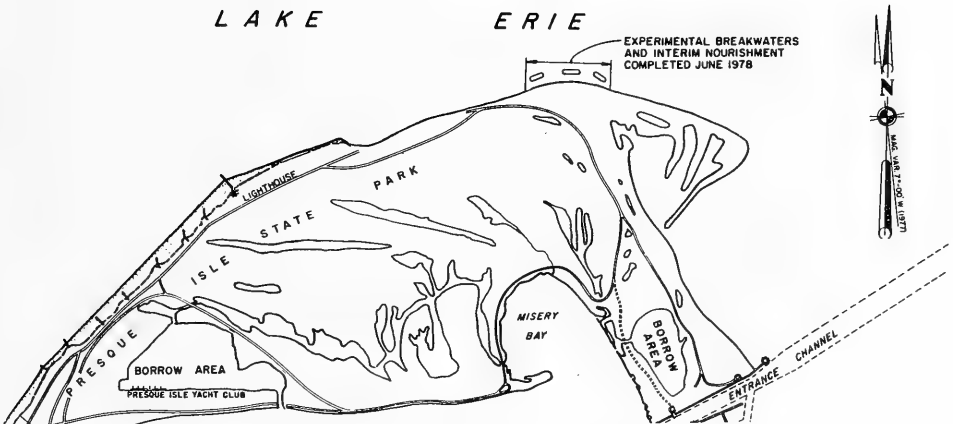


Figure 251. Presque Isle, Pennsylvania



Figure 252. Aerial view of Presque Isle, Pennsylvania

Table 92

Erie Harbor Piers  
Erie, Pennsylvania

<u>Date(s)</u>	<u>Construction and Rehabilitation History</u>
1825- 1900	Construction of a 3,248-ft-long north pier (Figure 253) was completed during this time. The pier was a stone-filled timber crib structure that ranged in width from 16.5 to 30 ft (Figure 254).
1827- 1903	Construction of a 2,215-ft-long south pier (Figure 253) was completed during this period. This pier was also a stone-filled timber crib structure that was 18 ft wide (Figure 254).
1903- 1909	Concrete and stone superstructures were installed on the north and south piers (Figure 254). The crest el of the south pier was +6.3 ft lwd, and the el of the north pier varied from section to section.
1953- 1956	Rehabilitation and repair of portions of the north pier were performed. Portions of the pier were repaired by the installation of steel sheetpiling, granular fill, and a new concrete cap (Figure 254, Sections A and D). A total of 1,141 ft of the north pier superstructure was rebuilt.
1979	A disposal dike was constructed adjacent to the south pier (Figure 253).
1984	Portions of the north pier were repaired (Figure 253, Sections A, F, and G). These piers were encased in steel sheetpiling. The voids between the sheetpiling and the existing timber cribs were granular filled, and the structure was recapped with concrete (Figure 255). The shoreward end of the north pier (Section A) was approximately 21 ft in width with a crest el of +7.3 ft lwd. The lakeward portions of the pier (Section F and G) were about 28 ft wide with an el of +9.8 ft lwd.
1986	The piers are presently considered to be in good condition. An aerial photo of the Erie Harbor piers prior to the construction of the disposal dike is shown in Figure 256.

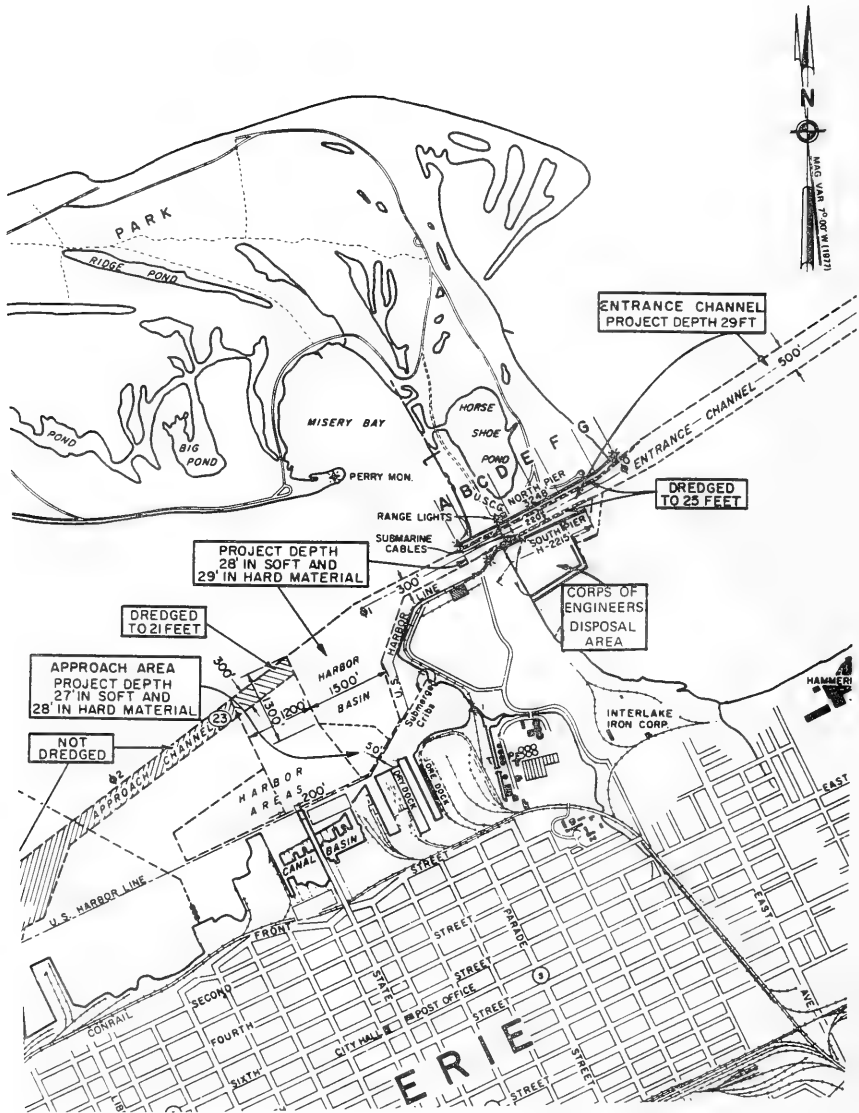
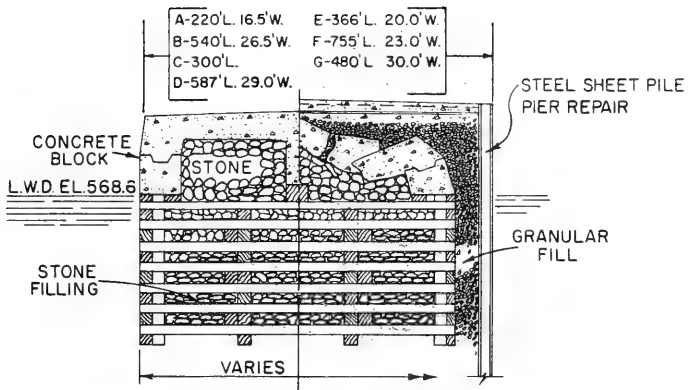


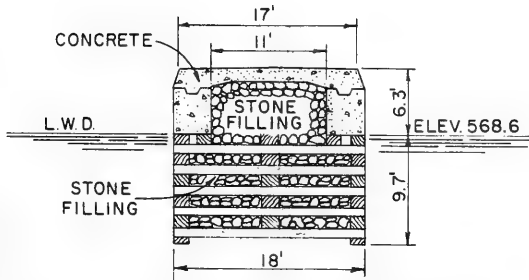
Figure 253. Erie Harbor, Pennsylvania



**SECTION OF NORTH PIER**

(BUILT 1825-1900 SUPERSTRUCTURE 1903-1909)  
 (REBUILT 1141 FEET OF SUPERSTRUCTURE 1953-1956)

A-REPAIRED IN 1953-1954  
 D-REPAIRED IN 1954-1955



**SECTION OF SOUTH PIER - H**

(BUILT 1827-1903 SUPERSTRUCTURE 1903-1909)

Figure 254. Typical pier cross sections,  
 Erie Harbor, Pennsylvania







Figure 256. Aerial view of Erie Harbor, Pennsylvania

Table 93

Barcelona Harbor BreakwatersBarcelona, New York

<u>Date(s)</u>	<u>Construction and Rehabilitation History</u>
1960	Construction of a 693-ft-long east and a 790-ft-long west breakwater (Figure 257) was completed. The breakwaters were constructed with cellular steel sheetpiling filled with granular fill and capped with concrete. The cell diameters were about 38 ft, and the els were +9 and +11 ft lwd for the east and west structures, respectively (Figure 257). A 174-ft-long steel sheet-pile shore arm connected the west breakwater to shore. Its el was +9 ft lwd.
1984	Construction of a 250-ft-long lakeward west breakwater extension, a 150-ft-long shoreward east breakwater extension, and segmented wave absorbers adjacent the harbor side of the west breakwater was completed (Figure 257). The modifications were constructed of rubble-mound materials. The west breakwater extension consisted of a structure with a crest el of +11 ft lwd, a crest width of 12 ft, side slopes of 1V:1.5H, and armor stones ranging from 7.5 to 16 tons. The east shoreward extension had an el of +8 ft lwd, a crest width of 8 ft, side slopes of 1V:1.5H, and armor stones ranging from 1.2 to 2.5 tons. The modifications were model tested prior to construction (Bottin 1984).
1986	The structures are presently in good condition. An aerial photo of the Barcelona Harbor breakwaters is shown in Figure 258.

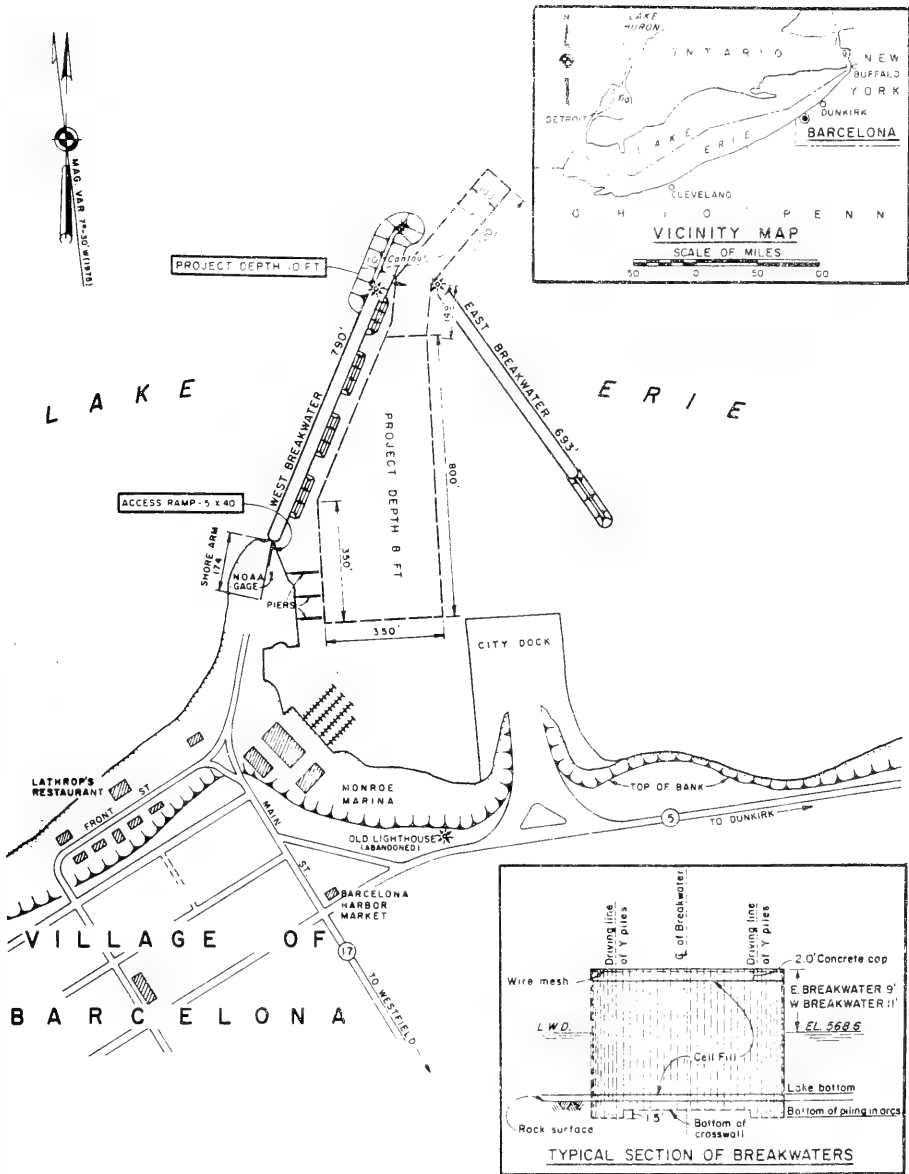


Figure 257. Barcelona Harbor, New York



Figure 258. Aerial view of Barcelona Harbor, New York

Table 94

Dunkirk Harbor StructuresDunkirk, New York

Date(s)	Construction and Rehabilitation History
1868- 1870	Construction of a 1,410-ft-long west pier (Figure 259, Section I) was completed during this time. The pier was constructed of concrete and stone (Figure 260, Section I) and was 30 ft in width.
1897- 1921	A concrete superstructure was installed on most of the west pier. The maximum el of the superstructure was +11.3 ft lwd (Figure 260, Section I). A small portion of the superstructure next to the shoreline was constructed with large stone.
1898	Construction of a 577-ft-long portion of the outer breakwater (Figure 259, Section J) was completed. The breakwater was a stone-filled timber crib structure that was 30 ft in width (Figure 260, Section J).
1899	Construction of a 2,237-ft-long portion of the outer breakwater (Figure 259, Sections G and H) was completed. The structure was 30 ft wide and consisted of stone-filled timber cribs (Figure 260, Sections G and H). A concrete superstructure was installed on a 310-ft-long portion of the breakwater (Section G). It had an el of +10.3 ft lwd (Figure 260).
1930	A concrete superstructure was installed on a 577-ft-long portion of the outer breakwater (Figure 259, Section J). The maximum el of the superstructure was +8 ft lwd (Figure 260, Section J). Stone riprap was placed along the lakeside at the west pier also during this year.
1931	A stone superstructure was installed on a 1,827-ft-long portion of the outer breakwater (Figure 259, Section H). The el of the superstructure was +8.3 ft, and it had a 10-ft crest width (Figure 260, Section H). The stone extended along the lakeside of the breakwater on a 1-V:1.5-H slope. A 110-ft-long portion of Section H (Figure 259) included a precast concrete superstructure.
1979- 1980	Construction of a 1,200-ft-long west and 1,464-ft-long east breakwater (Figure 259) was completed during this period. The structures were rubble mound with els of +11 ft lwd, crest widths of 10 ft, side slopes of 1V:1.5H, and armor stones ranging from 1,400 to 3,800 lbs.
1986	The inner rubble-mound breakwaters presently are in good condition, and the west pier and outer breakwater are considered to be in fair condition. The concrete portions of the superstructure of the outer breakwater and pier show signs of spalling and slight separation at the joints; however, no immediate action is required. The stone superstructure portions of the outer breakwater seem to have settled lakeward in areas, and additional stone has been recommended to increase the height of the structure to its original design. An aerial view of the Dunkirk Harbor structures is shown in Figure 261.

LAKE ERIE

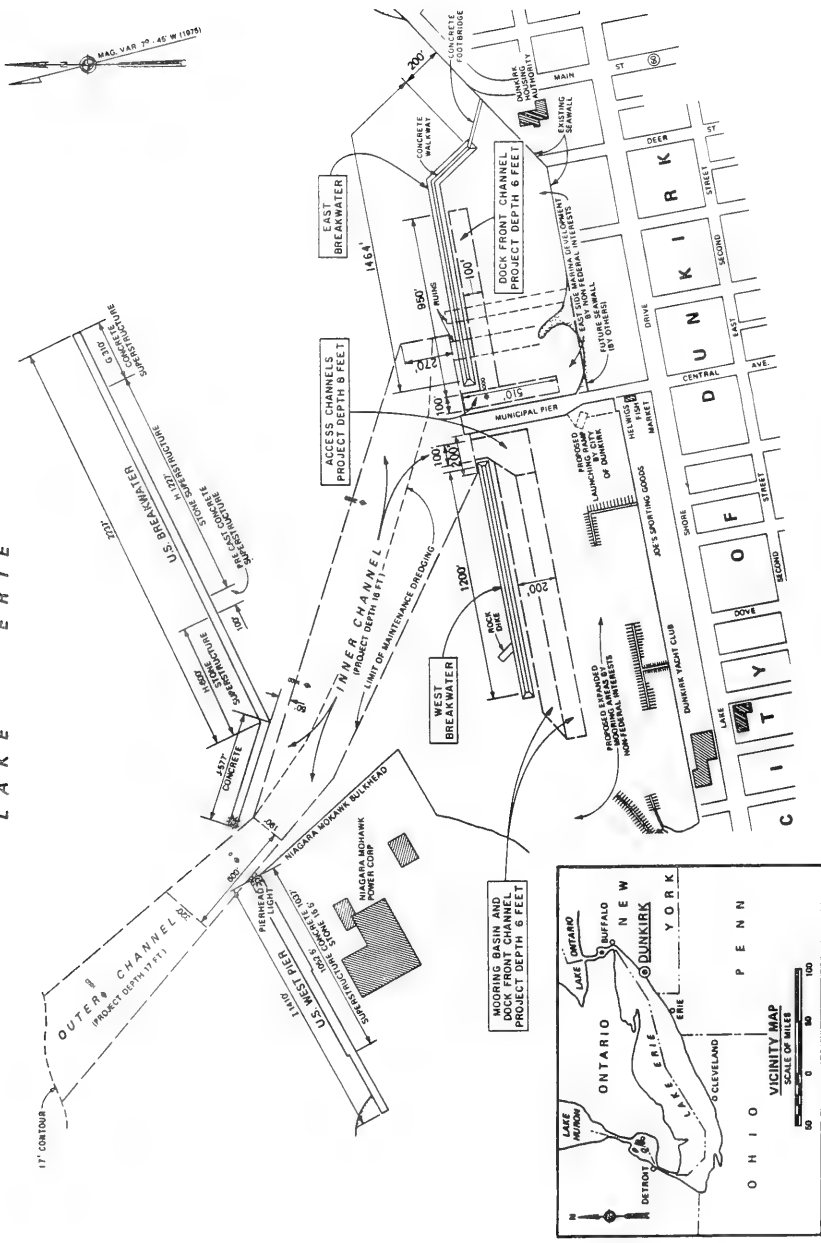
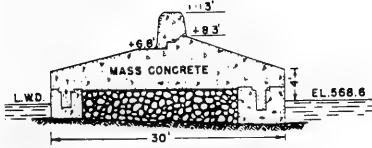
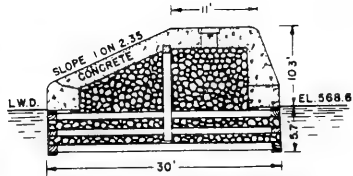


Figure 259. Dunkirk Harbor, New York



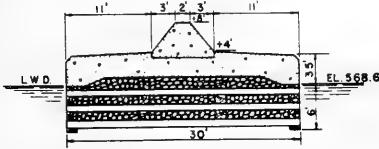
**SECTION OF WEST PIER -I-**

(BUILT 1868-1870)  
 CONC. SUPER-STRUCTURE 1897-1921  
 STONE RIPRAP 1930



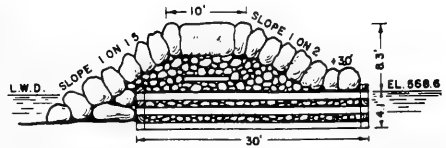
**SECTION OF BREAKWATER -G-**

(BUILT IN 1899)



**SECTION OF BREAKWATER -J-**

(BUILT IN 1898)  
 CONC. SUPER-STRUCTURE IN 1930

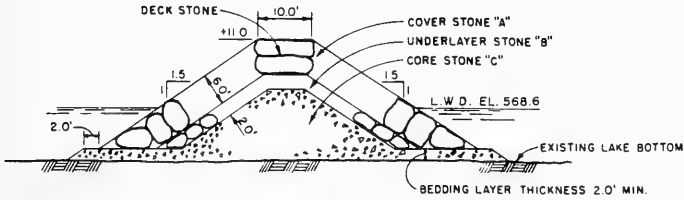


**SECTION OF BREAKWATER -H-**

(BUILT IN 1899 STONE SUPER-STRUCTURE IN 1931)

LAKESIDE

LANDSIDE



**EAST AND WEST INNER BREAKWATER**

(BUILT 1979-1980)

**STONE GRADATION**

- "A" Stone 1400 lbs. - 3800 lbs.
- "B" Stone 90 lbs. - 380 lbs.
- "C" Stone Chips - 20 lbs.

Figure 260. Typical structure cross sections, Dunkirk Harbor, New York



Figure 261. Aerial view of Dunkirk Harbor, New York



Cattaraugus Creek Harbor BreakwatersHanover, New York

Date(s)	Construction and Rehabilitation History
1983	Construction of two rubble-mound breakwaters was completed (Figure 262). The north breakwater was 600 ft long with a crest el of +12.5 ft lwd and a crest width of 11 ft (Figure 263). Side slopes were 1V:2H, and armor stone ranged from 2 to 5 tons. The south breakwater was 1,850 ft long and included armor stone that ranged from 4 to 9 tons. It included a +12.5 ft lwd crest el, a 13.5-ft crest width, and 1-V:2-H side slopes (Figure 263). The cost of construction was about \$6.1 million, which included a 550-ft-long berm attached to the north breakwater (Figure 262). The breakwater configuration was model tested prior to construction (Bottin and Chatham 1975).
1986	No maintenance repairs have been performed, and the structures are in good condition. An aerial photo of the Cattaraugus Creek breakwaters is shown in Figure 264.

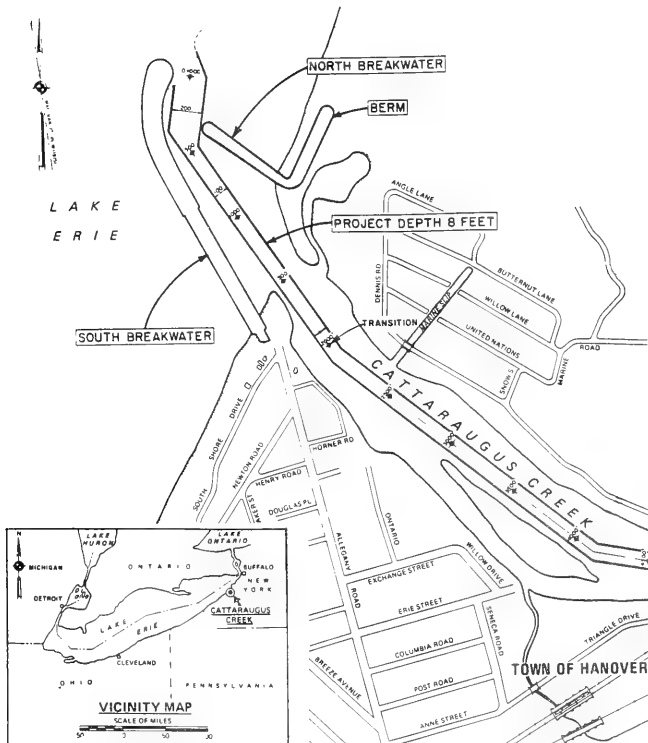
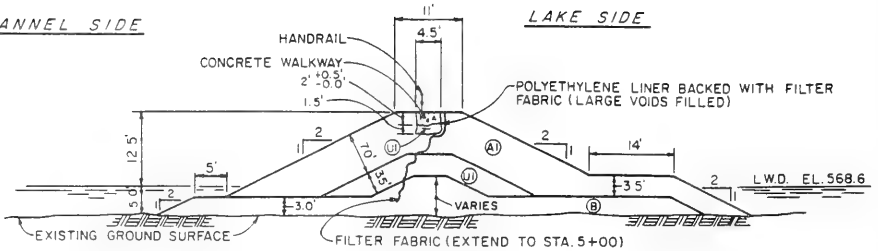


Figure 262. Cattaraugus Creek Harbor, New York

CHANNEL SIDE

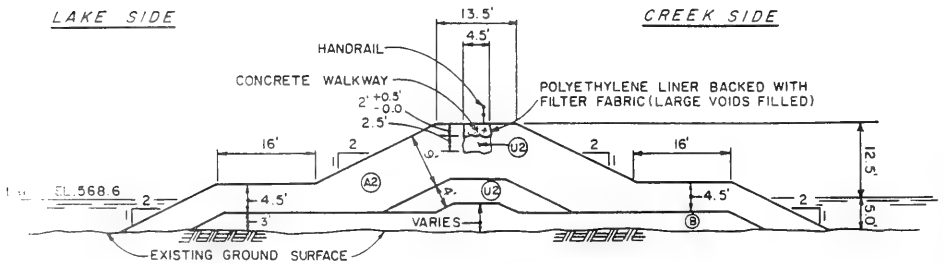
LAKE SIDE



TYPICAL SECTION OF NORTH BREAKWATER

LAKE SIDE

CREEK SIDE



TYPICAL SECTION OF SOUTH BREAKWATER

A1-ARMOR STONE: 2 TO 5 TONS

A2- 4 TO 9 TONS

A3- 6 TO 13 TONS

B-BEDDING STONE: 6" TO 10" IN.

U1-UNDERLAYER STONE: 240 TO 950 LBS.

U2- 460 TO 1850 LBS.

U3- 640 TO 2550 LBS.

Figure 263. Typical breakwater cross sections,  
Cattaraugus Creek Harbor, New York

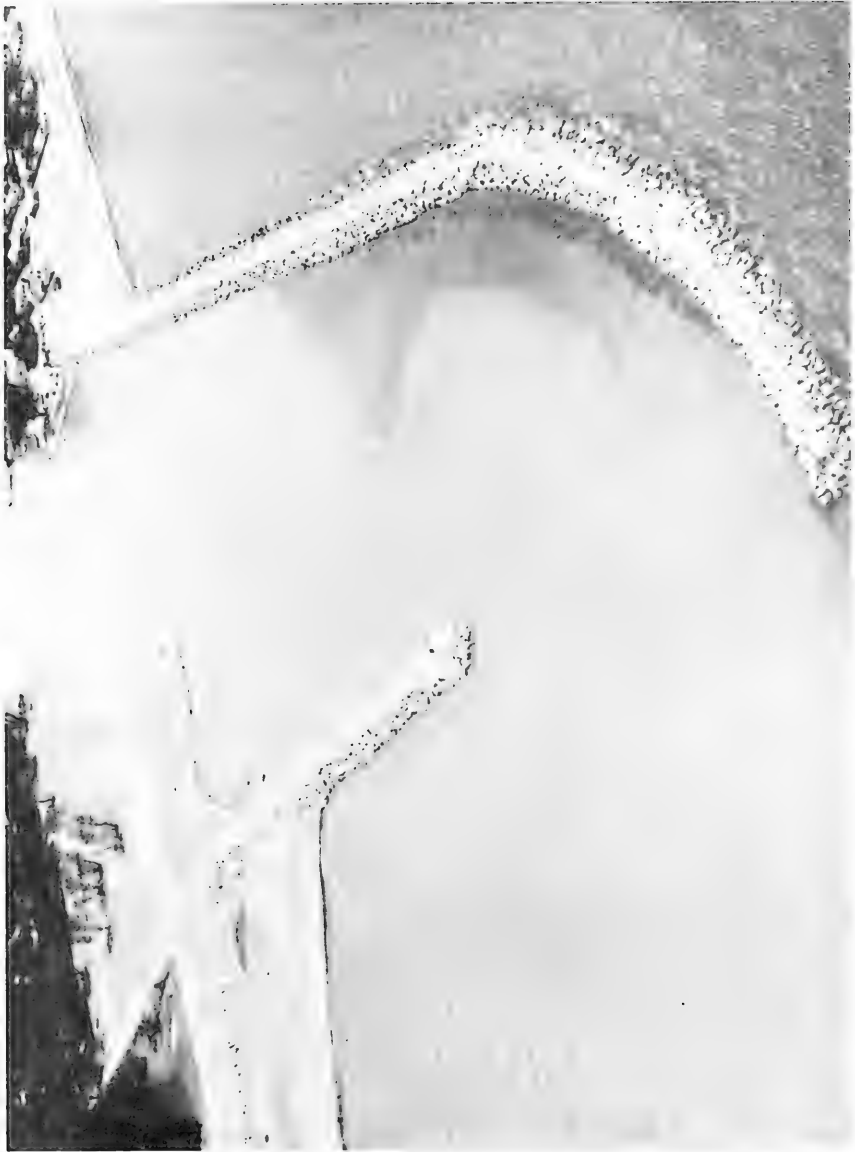


Figure 264. Aerial view of Cattaraugus Creek Harbor, New York

Table 96

Buffalo Harbor BreakwaterBuffalo, New York

Date(s)	Construction and Rehabilitation History
1869- 1893	Construction of the Old Breakwater (Figure 265, Sections C and D) was completed during this period. The original length of the structure was 7,609 ft, and it consisted of stone-filled timber cribs (Figure 266, Section C and Figure 267, Section D) that were 36-ft in width.
1889	A concrete superstructure was installed on a portion of the Old Breakwater (Figure 265, Section C). The crest el of the structure was +14.5 ft lwd (Figure 266, Section C).
1897- 1898	Construction of the 1,603-ft-long Stony Point breakwater (Figure 265, Section K) was completed. It consisted of 36-ft-wide stone-filled timber cribs (Figure 266, Section K).
1897- 1902	Construction of a 2,204-ft-long north breakwater (Figure 265, Sections A and B) and a 10,200-ft-long south breakwater (Figure 265, Sections E, F, G, and H) was completed during this time. The north breakwater was constructed with 24-ft-wide (Figure 268, Section B) and 36-ft-wide (Figure 268, Section A) stone-filled timber cribs. Concrete and stone superstructures were included which had crest els of +13.5 ft lwd (Figure 268, Sections A and B). Portions of the south breakwater were constructed with 36-ft-wide stone-filled timber cribs (Figure 266, Section G and Figure 268, Sections F and H). Section G (Figure 266) included a concrete and stone superstructure with a crest el of +15 ft lwd. Section H (Figure 268) included a concrete superstructure with an el of +14.5 ft lwd, and Section F (Figure 268) had a stone superstructure with an el of +14.5 ft lwd and a 14-ft-wide crest width sloping to the lake on the lakeside. Section E (Figure 266) was a rubble-mound structure with a crest el of +14.5 ft and a width of 14 ft. Slopes on the harbor side ranged from 1V:0.7H to 1V:1.22H to 1V:2.5H. Armor stone on the lakeside was approximately 6.5 tons in weight.
1902- 1927	Riprap was placed on the lakeside of a portion of the south breakwater (Figures 265 and 266, Section G). The stone ranged from 0.5 to 4 tons each.
1907- 1924	A stone superstructure with a concrete cap was installed on a portion of the Old Breakwater (Figures 265 and 267, Section D). The crest of the breakwater was 12 ft in width with a crest el of +14.5 ft lwd. Slopes on the harbor side were 1V:0.7H, and slopes on the lakeside ranged from 1V:1.25H to 1V:2.5H.
1923- 1924	A stone superstructure with a concrete cap was placed on the Stony Point breakwater (Figures 265 and 266, Section K). The structure had

(Continued)

Table 96 (Concluded)

Date(s)	Construction and Rehabilitation History
	a crest el of +12 ft lwd with slopes of 1V:1H on the harbor side and 1V:1.5H on the lakeside.
1930- 1934	Major repairs were performed on portions of the Old Breakwater (Figures 265 and 266, Section C). Portions of the concrete super-structure were replaced, and a protective stone slope was installed on the lakeside of the structure.
1936	A 2,000-ft-long south entrance arm breakwater (Figure 265, Section J) was constructed. The structure was built with rubble-mound materials and had a +14.2 ft lwd crest el with a 10-ft width. Slopes on the harbor side were 1V:1.3 and 1V:1.5H, and slopes on the lakeside were 1V:1.5H. Armor stone weight was 3 tons (min), with not less than 50 percent being 5 tons or more.
1959- 1962	A portion of the Old Breakwater was removed, resulting in a 982-ft gap for a new entrance channel (Figure 265). A 1,800-ft-long rubble-mound west breakwater (Figure 265) with a concrete cap was constructed to provide wave protection to the new entrance. The breakwater had a crest el of +12.2 ft with a width of 8 ft. Side slopes were 1V:1.3H on the harbor side and 1V:1.5H on the lakeside. Armor stone was 7 tons (min) each. These modifications were model tested prior to construction (Hudson, Housley, and Wilson 1960).
1964- 1965	Rehabilitation of portions of the old breakwater (Figure 265) was completed. Repairs consisted of reconstruction of the stone slopes adjacent to the sea sides of the structures. The cost of improvements was about \$220,000.
1977	A disposal dike was constructed adjacent to the south entrance arm breakwater (Figure 265).
1982	A major storm occurred in January with wind gusts reaching 75 mph, resulting in extraordinary sized storm waves. An inspection of the harbor breakwaters subsequent to the storm revealed damages to about 300 ft of the north breakwater. Concrete caps were dislodged, and core stone was exposed. Rehabilitation was recommended.
1983- 1984	Recommended repairs with stone and concrete to about 300 ft north of the breakwater were completed for a cost of about \$900,000. New armor stone ranging from 6 to 13 tons was utilized (Figure 269). The crest of the new stone was +13.5 ft lwd.
1986	The breakwaters are presently considered to be in good to fair condition. There are isolated areas of settlement along the length of the Old Breakwater, the south breakwater, and the west breakwater. No immediate repairs are required, but the structures are being monitored for signs of accelerated deterioration. An aerial view of the Buffalo Harbor breakwaters is shown in Figure 270.

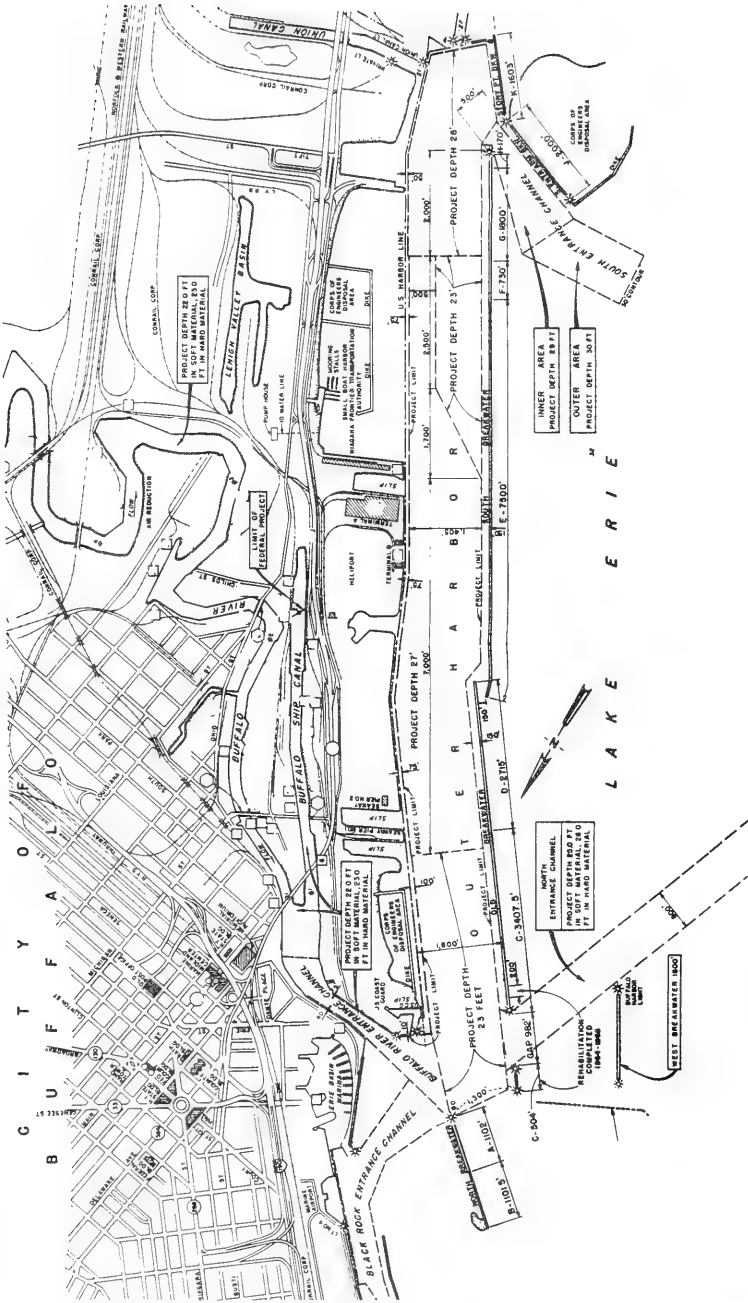
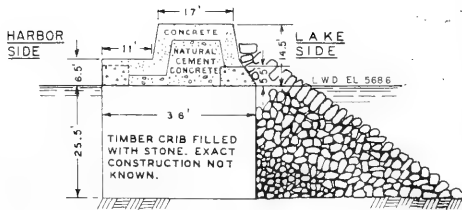
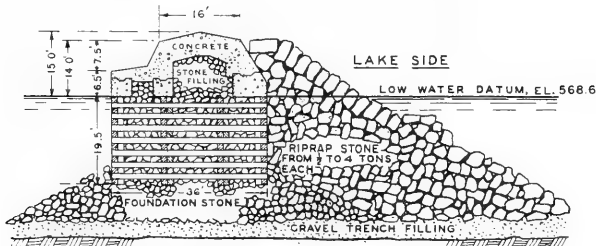


Figure 265. Buffalo Harbor, New York

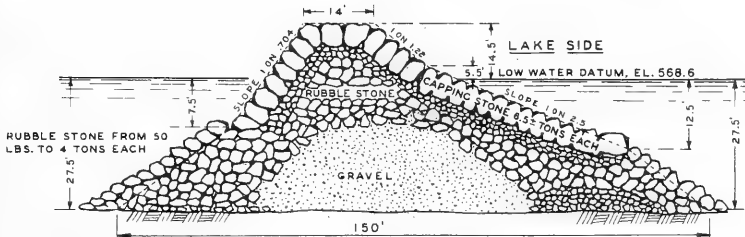


SECTION OF OLD BREAKWATER - C-  
(BUILT SUPER-STRUCTURE 1889)

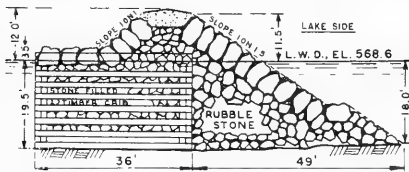
Rehabilitation of portions of Section C commenced on 24 May 1964. The northerly 451 feet of the breakwater northerly of the North Entrance Channel, and a 200 foot section about 300 feet southerly of the North Entrance Channel were repaired and additional riprap on the harbor side was placed. Rehabilitation was completed on 31 August 1965.



SECTION OF SOUTH BREAKWATER - G-  
(BUILT 1897-1902)  
(SUPER-STRUCTURE 1902-1927)

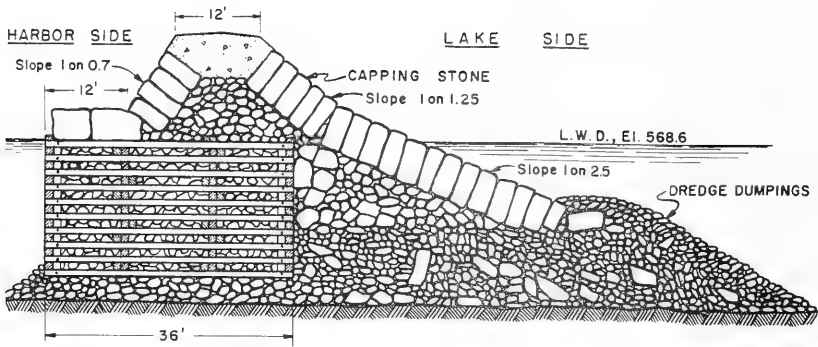


SECTION OF SOUTH BREAKWATER - E-  
(BUILT 1897-1902)



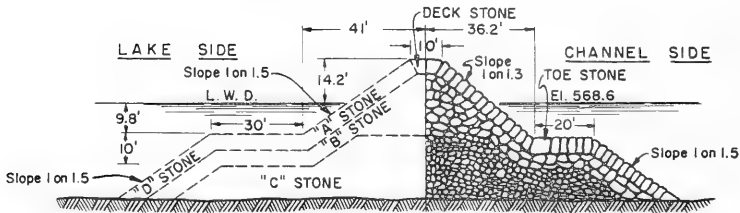
SECTION OF STONY PT. BKW. - K-  
(BUILT 1897-1898) (SUPER-STRUCTURE 1923-1924)

Figure 266. Typical old, south, and Stony Pt. breakwater cross sections, Buffalo Harbor, New York



**SECTION OF OLD BREAKWATER -O-**

( SUB-STRUCTURE BUILT 1869-1893 )  
 ( SUPER-STRUCTURE BUILT 1907-1924 )



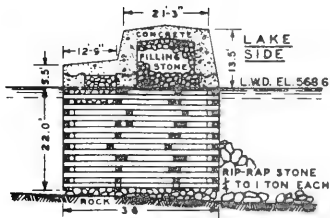
**SECTION OF SOUTH ENTRANCE  
 ARM BREAKWATER -J-**

( BUILT IN 1936 )

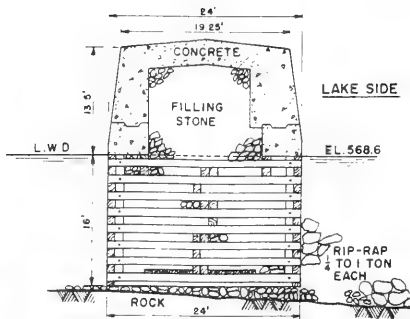
- Deck Stone - Minimum weight 5 tons
- "A" Stone - Minimum weight 3 tons, not less than 50% 5 tons or more.
- "D" Stone - Minimum weight 3 tons
- Toe Stone - Minimum weight 7 tons
- "B" Stone - Minimum weight 100 pounds.
- "C" Stone - Not less than 35% 75 pounds or more, not more than 3% less than one pound.

Figure 267. Typical old and south entrance arm breakwater cross sections, Buffalo Harbor, New York

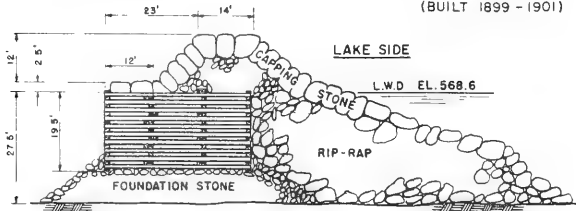




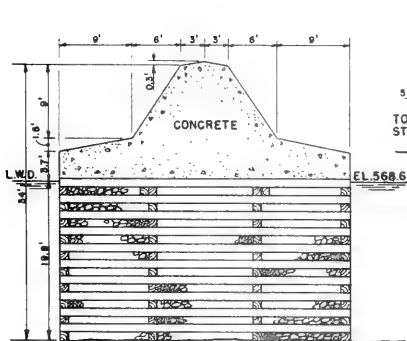
**SECTION OF  
NORTH BREAKWATER -A-**  
(BUILT 1899 - 1901)



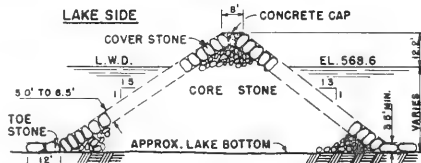
**SECTION OF  
NORTH BREAKWATER -B-**  
(BUILT 1899 - 1901)



**SECTION OF  
SOUTH BREAKWATER -F-**

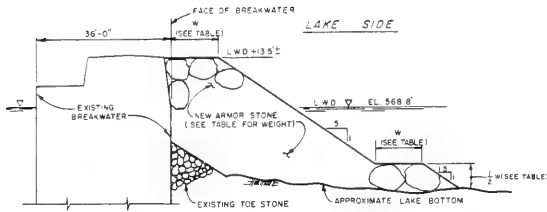


**SECTION OF  
SOUTH BREAKWATER -H-**

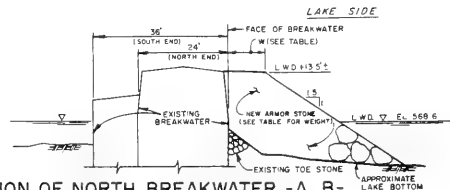


**SECTION OF  
WEST BREAKWATER**

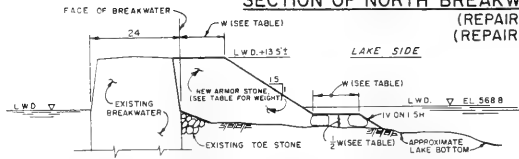
Figure 268. Typical structure cross sections,  
Buffalo Harbor, New York



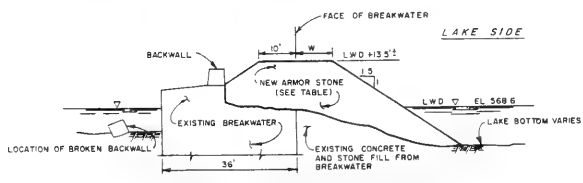
**SECTION OF NORTH BREAKWATER -A-  
(SOUTH END SECTION REPAIRED 1984)**



**SECTION OF NORTH BREAKWATER -A, B-  
(REPAIRED 1982)  
(REPAIRED 1984)**



**SECTION OF NORTH BREAKWATER -B-  
(NORTH END SECTION REPAIRED 1984)**



**SECTION OF NORTH BREAKWATER -A-  
(REPAIRED 1982)**

**ARMOR STONE**

SECTION -A		SECTION -B		SECTION -A and B	
"W" FEET	TONS	"W" FEET	TONS	"W" FEET	TONS
11	9-13	9	6-10	10	6-13
11	9-13	9	6-10	10	6-13
12	10-15	9	7-11	10.5	7-15

**Figure 269. Typical north breakwater cross sections,  
Buffalo Harbor, New York**



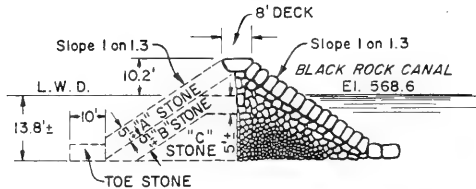
Figure 270. Aerial View of Buffalo Harbor, New York

Table 97  
Bird Island Pier  
Black Rock Channel, Buffalo, New York

<u>Date(s)</u>	<u>Construction and Rehabilitation History</u>
1822- 1825	Construction of a 6,606.5-ft-long portion of the pier (Figure 271, Section Z) was completed during this time period. The structure consisted of stone-filled timber cribs that were 18 ft in width (Figure 272, Section Z). The pier originally included a timber deck.
1837- 1937	The entire 6,605.5-ft-long structure (Figure 271, Section Z) was rebuilt during this period. The pier was capped with stone to an el of about +9 ft lwd, and stone slopes were included on each side of the pier (Figure 271, Section Z).
1869- 1892	A 3,100-ft-long extension of the pier (Figure 271, Section Y) was completed during this time. The extension consisted of stone-filled timber cribs that were 20 ft in width (Figure 272, Section Y). A timber deck was installed initially.
1928- 1929	The 3,100-ft-long pier extension (Figure 271, Section Y) was capped with a concrete superstructure. The maximum el of the superstructure was +10 ft lwd (Figure 272, Section Y).
1928- 1938	An additional 800-ft-long extension of the pier (Figure 271, Section X) was completed during this period. This extension was a rubble-mound structure with an 8-ft-wide crest with an el of +10.2 ft lwd. Side slopes were 1V:1.3H, and armor stone weighed 3 tons (minimum) with not less than 50 percent of 5 tons or more.
1986	No records of maintenance to the pier are available, and the present condition is not known.

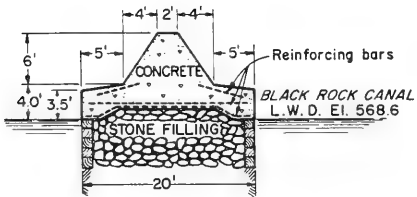


Figure 271. Black Rock Channel, New York



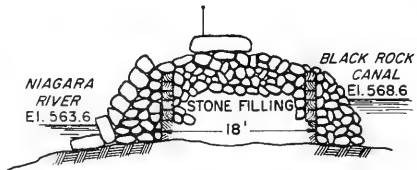
**SECTION X**  
(BUILT 1929 - 1938)

- Deck Stone - Minimum weight 5 tons.
- "A" Stone - Minimum weight 3 tons, not less than 50%  
5 tons or more.
- "B" Stone - Minimum weight 150 pounds.
- "C" Stone - Not less than 35% 75 pounds or more, not  
more than 3% less than one pound.
- Toe Stone - Minimum weight 7 tons



**SECTION Y**

BUILT: SUB-STRUCTURE 1869-1892  
SUPER-STRUCTURE 1928-1929



**SECTION Z**  
(BUILT 1822 - 1825)  
(REBUILT 1837 - 1937)

TYPICAL SECTIONS OF BIRD ISLAND PIER

Figure 272. Typical structure cross sections,  
Black Rock Channel, New York

Table 98

Wilson Harbor PiersWilson, New York

Date(s)	Construction and Rehabilitation History
1878- 1883	Construction of parallel piers at the site (Figure 273) was completed by private interests. The structures were initially stone-filled timber cribs with timber decks.
1949	The piers were rehabilitated by the US Government as authorized by the River and Harbor Act of 1945. The shoreward 264.9 ft and 149.4 ft of the east and west piers, respectively, were constructed of steel sheetpile at an el of +7.25 ft lwd. The lakeward 398.8 ft of the east pier and the adjacent 356.1 ft of the west pier were repaired by encasing the original timber cribs with steel sheet-piling. The area between the sheetpiling was filled with gravel and capped with concrete (Figure 273). The piers were 22.75 ft wide and had an el of +7.5 ft lwd.
1950	A 161.3-ft-long lakeward extension of the west pier was completed resulting in a total pier length of 666.8 ft. The pier was constructed with parallel steel walls filled with gravel and capped with concrete. It was 22.75 ft wide and had an el of +7.5 ft lwd.
1964	A 200-ft-long stone walkway with a concrete cap was constructed adjacent to the east pier (Figure 273).
1986	Routine maintenance repairs have been performed over the years, and the structures are presently considered to be in good condition. An aerial view of the Wilson Harbor piers is shown in Figure 274.







Figure 274. Aerial view of Wilson Harbor, New York

Table 99

Olcott Harbor PiersOlcott, New York

Date(s)	Construction and Rehabilitation History
1918	Construction of an 850-ft-long east pier and an 873-ft-long west pier (Figure 275) was completed. The piers were originally of stone-filled timber crib construction with timber decks.
1930	The east and west piers were capped with stone and concrete superstructures.
1949	Repairs were made to an 800-ft-long portion of the east pier (Figure 275) by driving rows of sheetpiling on each side of the pier, filling the voids with granular fill, and capping the structure with concrete (Figure 276). The pier width was 20 ft, and it had an el of +6.0 ft lwd. The concrete superstructure extended shoreward an additional 22 ft shoreward of the repair section (Figure 275).
1963	Rehabilitation of a 614-ft-long portion of the west pier (Figure 275) was completed which consisted of encasing the existing structure in steel sheet piles (Figure 276). The voids between the old pier and the new steel sheetpiling were granular filled, and the structure was capped with concrete to an el of +7.0 ft lwd. The width of the pier on the lakeward end was about 26 ft (Figures 275, Section A and 276).
1973	Emergency repairs to the west pier were performed consisting of repairs to the stone in portions of the structure and recapping the pier with concrete.
1986	Routine maintenance has been performed on the structures over the years, and they presently are in good condition. An aerial photo of the Olcott Harbor piers is shown in Figure 277.

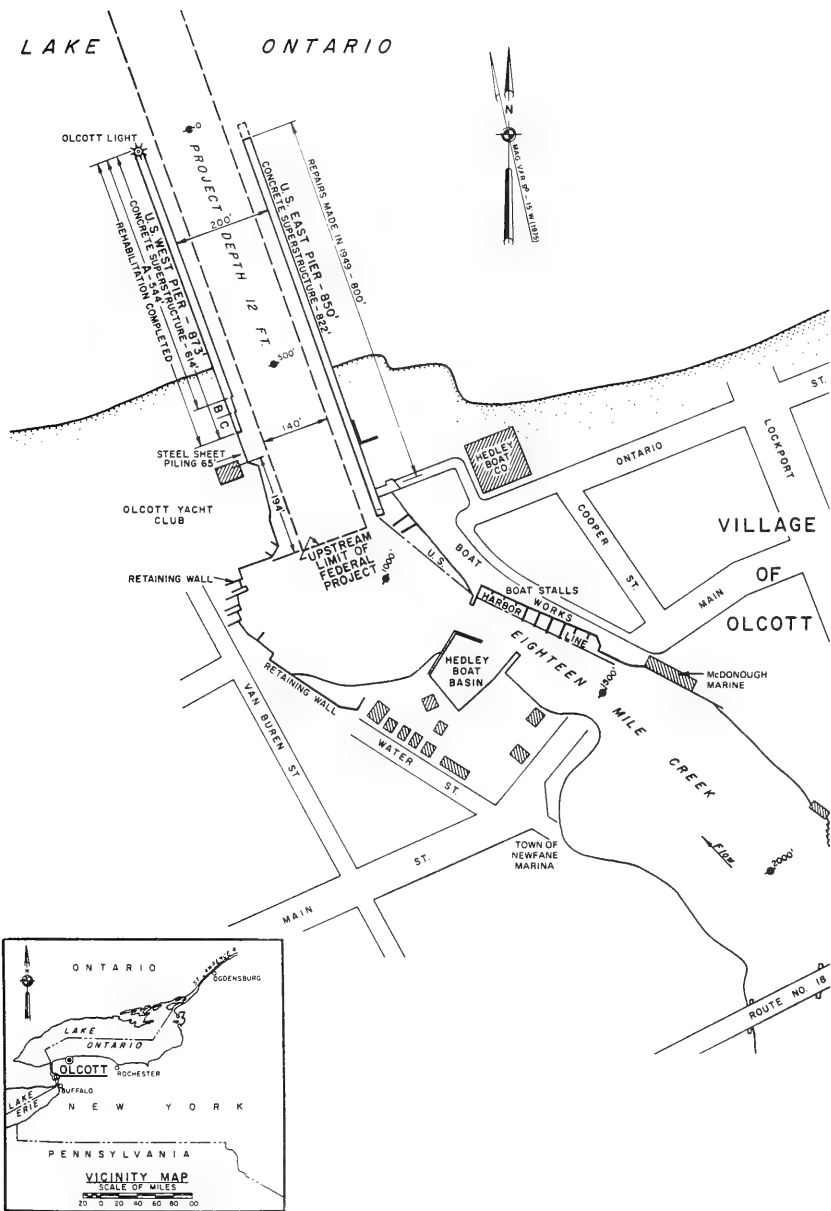


Figure 275. Olcott Harbor, New York

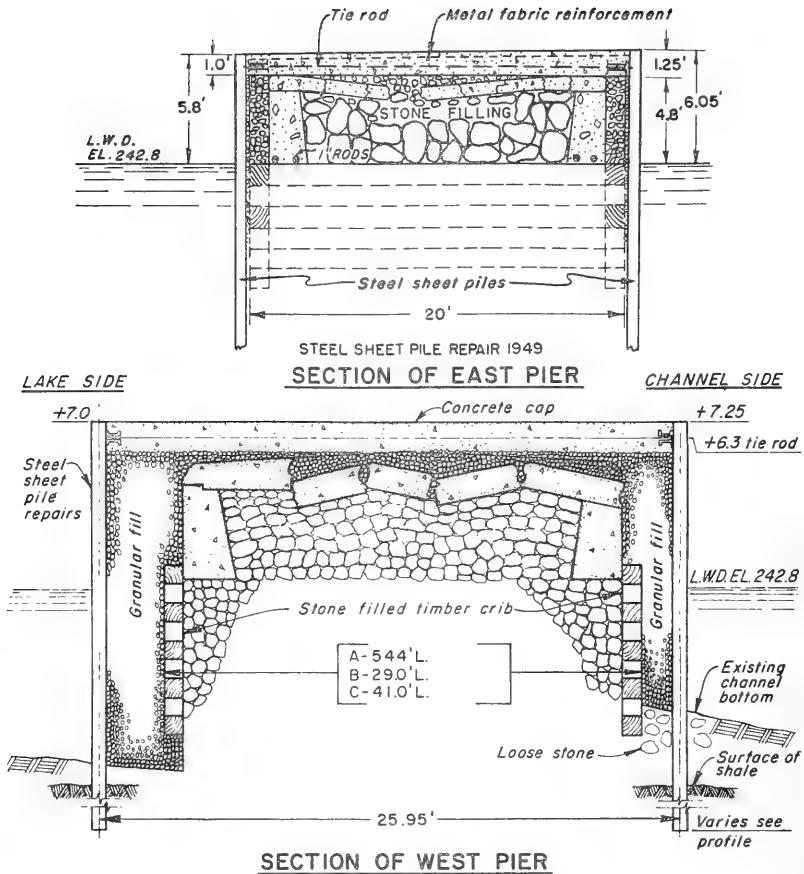


Figure 276. Typical pier cross sections, Olcott Harbor, New York



Figure 277. Aerial view of Olcott Harbor, New York

Table 100

Oak Orchard Harbor StructuresOak Orchard, New York

<u>Date(s)</u>	<u>Construction and Rehabilitation History</u>
1975	Construction of parallel piers and a detached breakwater (Figure 278) was completed at the mouth of Oak Orchard Creek. The east and west piers were rubble-mound structures that were 670 and 900 ft long, respectively. They had crest els of +8 ft lwd, crest widths of 12 ft, and cover stones ranging from 3.5 to 7 tons with 50 percent or more of the total stones weighing at least 4.5 tons (Figure 279). A concrete walkway was also installed. The detached breakwater was 550 ft in length and of cellular steel sheet-pile construction. Cell diameters were about 36 ft and included granular fill and concrete caps (Figure 279). The crest el of the breakwater was +8 ft lwd.
1986	No record of maintenance to the structures is available, and they are considered to be in good condition. An aerial view of the Oak Orchard Harbor structures is shown in Figure 280.

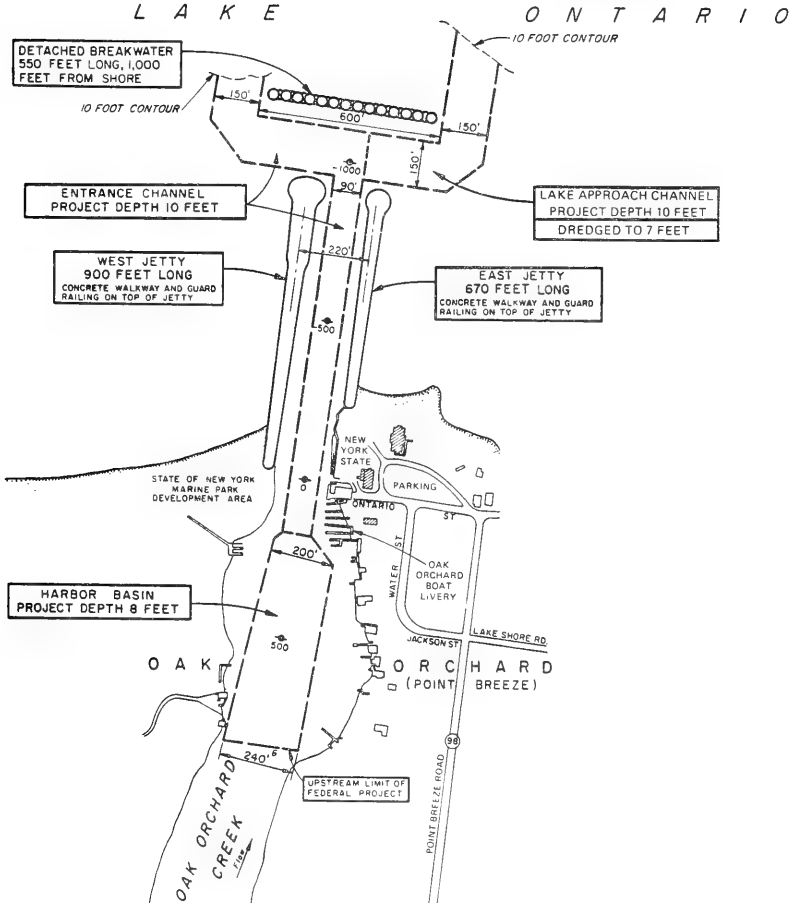
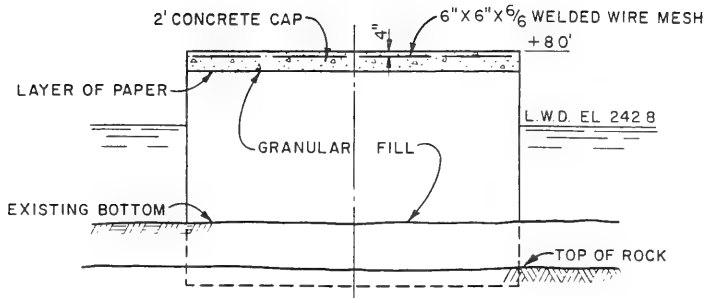
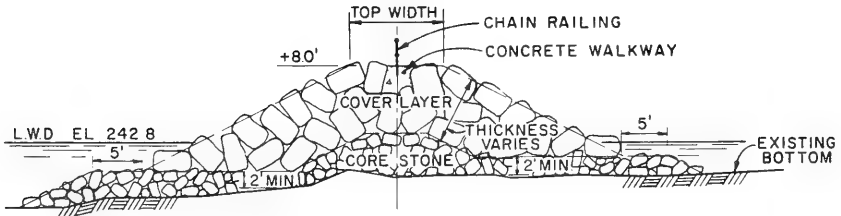


Figure 278. Oak Orchard Harbor, New York



TYPICAL SECTION OF CELLULAR STEEL SHEET PILE DETACHED BREAKWATER



TYPICAL SECTION OF EAST AND WEST JETTIES

Figure 279. Typical structure cross sections, Oak Orchard Harbor, New York





Figure 280. Aerial view of Oak Orchard Harbor, New York

Table 101  
Rochester Harbor Piers  
Rochester, New York

<u>Date(s)</u>	<u>Construction and Rehabilitation History</u>
1835	Construction of two parallel piers at the mouth of the Genesee River (Figure 281) was completed. The lengths of the east and west piers were 2,706 ft and 3,064 ft, respectively. The structures were originally constructed of 20-ft-wide stone-filled timber cribs with stone and concrete superstructures (Figure 282) with crest els of +7.5 ft lwd.
1934	Rehabilitation of a 345-ft-long portion of the west pier was completed (Figure 281). Repairs consisted of encasing the original structure with steel sheetpiling (Figure 282). The pier was capped with concrete to an el of 7.37 ft lwd, and the width of the structure was 22.63 ft.
1938	A 238-ft-long portion of the west pier (Figure 281) was rehabilitated. Construction was similar to that of 1934.
1948- 1949	The lakeward 901 ft of the west pier was rehabilitated (Figure 281). Steel sheet pile was driven on each side of the existing structure (about 27 ft apart). The voids between the sheetpiling and the existing structure were granular filled, and the pier was capped with concrete to an el of +8 ft lwd (Figure 282).
1954	Rehabilitation of the lakeward 551-ft-long portion of the east pier was completed (Figure 281). The repairs were similar to those of the west pier completed during 1948-49 (Figure 282).
1971	Additional rehabilitation of the 706 ft of the east pier was completed (Figure 281). Repair methods consisted of parallel steel sheetpiling, granular fill, and a concrete cap, similar to that done previously (Figure 282).
1980- 1981	Rehabilitation of a 410-ft-long portion (Figure 281) of the west pier was completed. Repairs consisted of the installation of parallel steel sheet-pile walls (on each side of the existing structure). Voids were granular filled, and the pier was capped with concrete. The crest el of the repaired structure was +7.5 ft lwd, and the pier width was 22 ft.
1983- 1984	A 1,125-ft-long portion of the west pier (Figure 281) was rehabilitated. Repairs were similar to those done previously by encasing the existing structure in steel sheetpiling, filling the voids with granular fill, and capping the structure with concrete.
1986	The structures presently are in good condition with the exception of minor repairs needed on the shoreward ends of both piers. An aerial photo of the Rochester Harbor piers is shown in Figure 283.

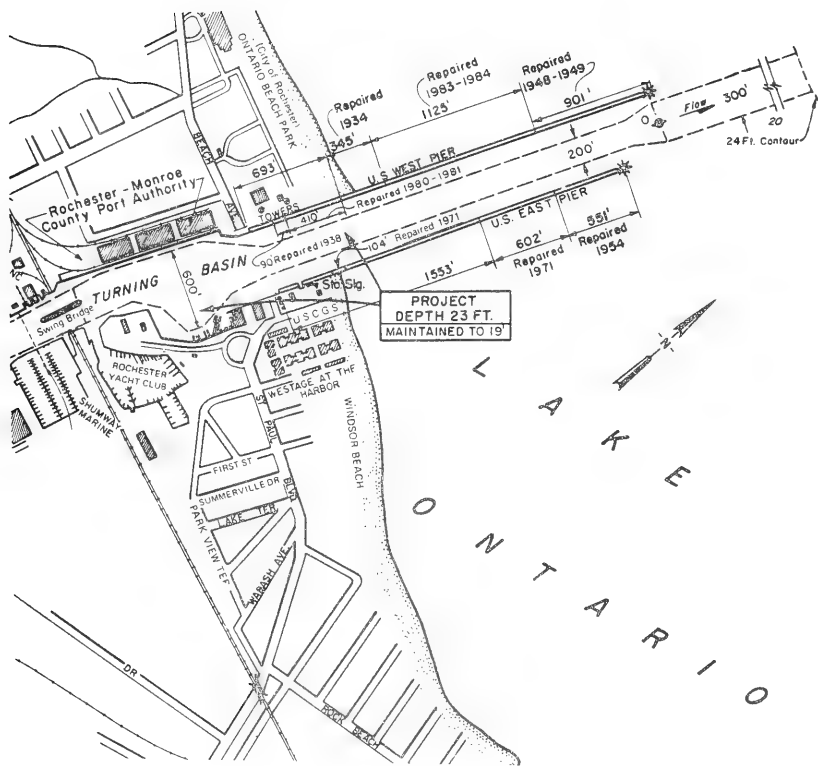
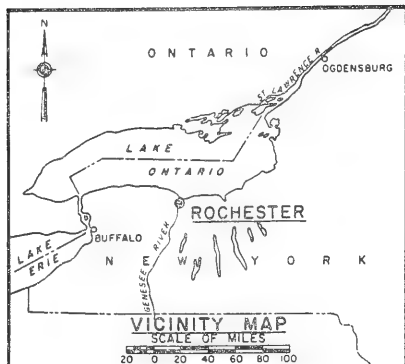


Figure 281. Rochester Harbor, New York

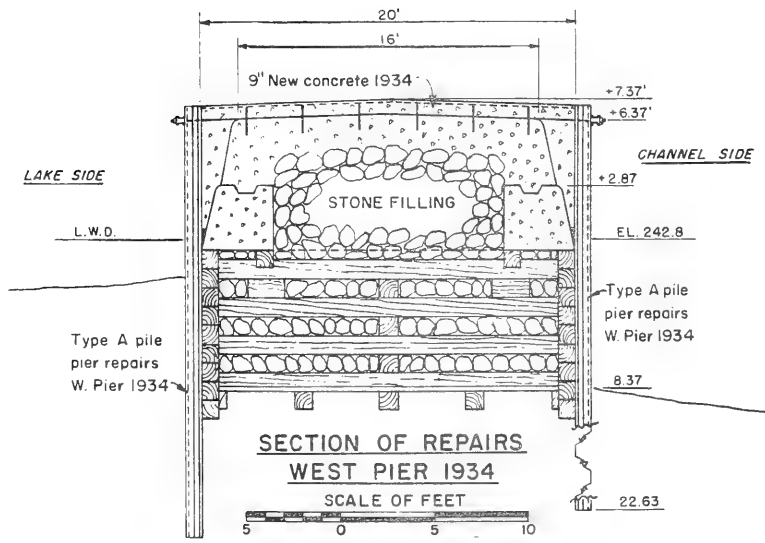
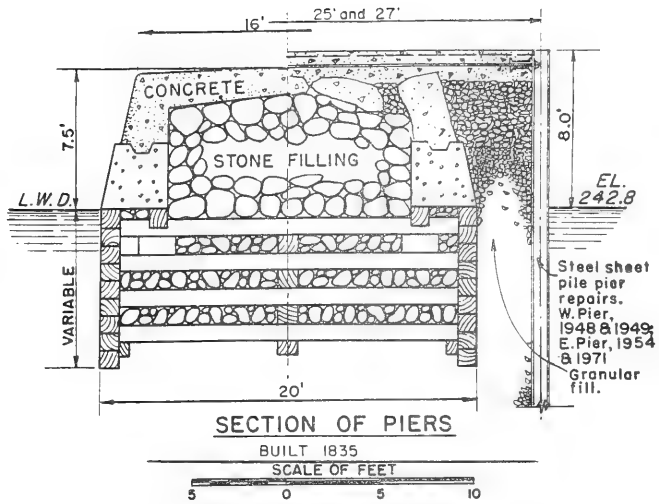


Figure 282. Typical pier cross sections, Rochester Harbor, New York



Figure 283. Aerial view of Rochester Harbor, New York

Irondequoit Bay StructuresIrondequoit Bay, New York

Date(s)	Construction and Rehabilitation History
1985	<p>Construction of a 1,350-ft-long west breakwater and a 750-ft-long east jetty (Figure 284) was completed. The structures were built of rubble-mound materials with crest elevations of +10 ft lwd (Figure 285). The trunk section of the east jetty had an 11-ft-wide crest width, 1-V:1.5-H side slopes, and 0.5- to 1.5-ton armor stone. The east jetty head section and the shoreward arm of the west breakwater had crest widths of 14 ft and armor stones ranging from 3.0 to 6.5 tons. The head section of the east jetty had side slopes of 1V:2H. The lakeward arm of the west breakwater included armor stone ranging from 7 to 15.5 tons and a crest width of 16 ft. Side slopes of the west breakwater were 1V:1.5H, with the exception of the head which had 1-V:2-H slopes. An aerial view of the Irondequoit Bay structures taken during construction is shown in Figure 286. (Note the channel had not been dredged.)</p>

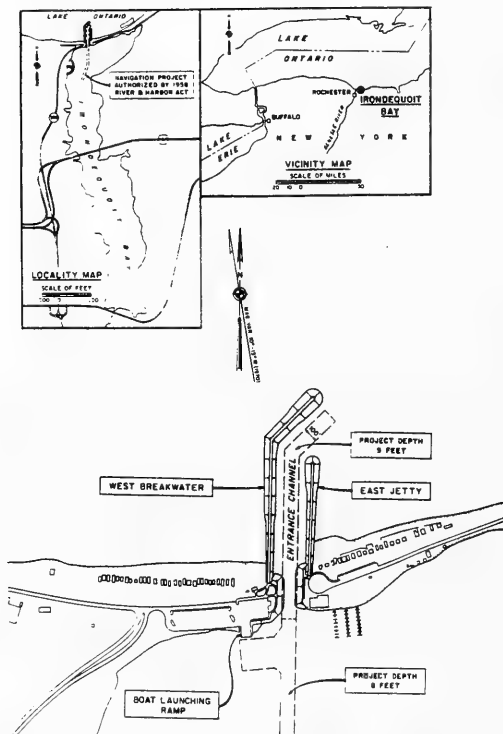
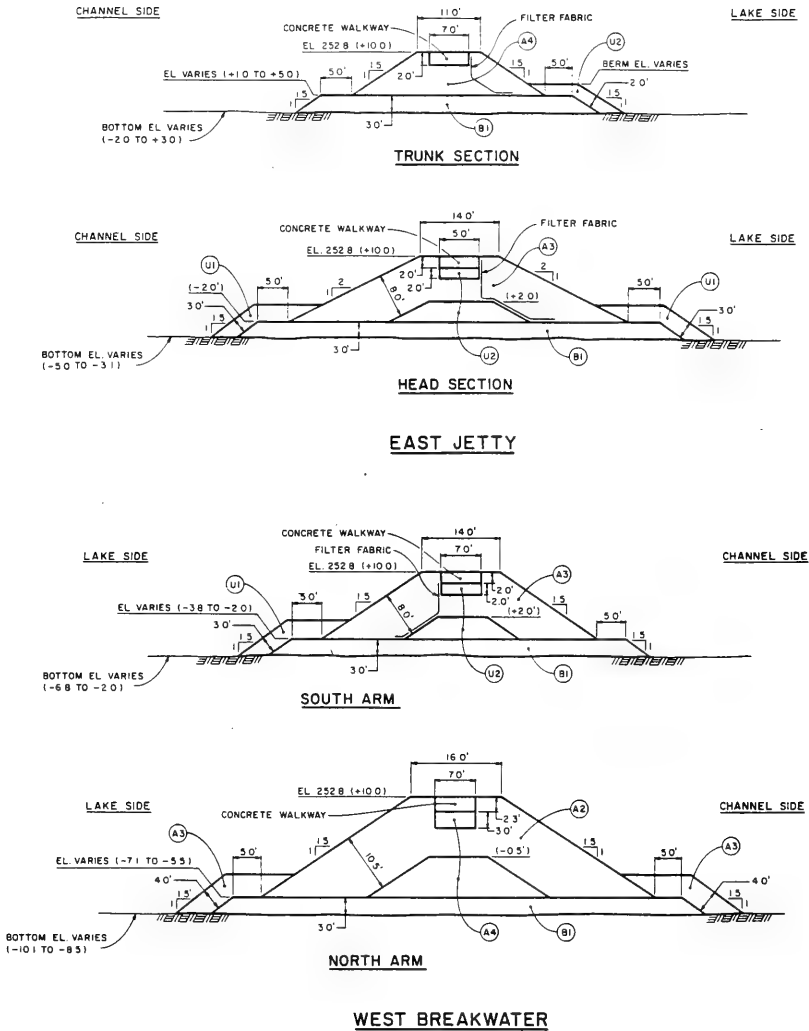


Figure 284. Irondequoit Bay, New York



**WEST BREAKWATER**

- A2 ARMOR STONE 7.0 TO 15.5 TONS
- A3 3.0 TO 6.5 TONS
- A4 0.5 TO 1.5 TONS
- B1 BEDDING MATERIAL 0 TO 15 IN.
- U1 UNDERLAYER STONE 1500 TO 5000 LBS.
- U2 400 TO 1300 LBS.

Figure 285. Typical structure cross sections, Irondequoit Bay, New York



Figure 286. Aerial view of Irondequoit Bay, New York



Table 103

Great Sodus Bay Harbor StructuresSodus Point, New York

Date(s)	Construction and Rehabilitation History
1910- 1919	Construction of a 1,294-ft-long east pier and and 1,580-ft-long west pier (Figure 287) was completed during this time. The piers consisted of stone-filled timber crib construction with stone and concrete superstructures (Figure 288). The structures were 18 ft in width and had crest els of +7.4 ft lwd.
1920- 1931	Construction of a 1,653-ft-long east breakwater (Figure 287) was completed during this period. The breakwater consisted of stone-filled timber cribs with a concrete cap (Figure 288). It was 14 ft wide and had a maximum el of +7.4 ft lwd.
1948	Rehabilitation of the east breakwater was performed which included the installation of steel sheet-pile walls on each side of the existing structure. The voids between the old timber crib and the new sheetpiling were filled with stone, and the breakwater was capped with concrete to an el of +8.5 ft lwd.
1958	A 503-ft-long portion of the west pier was repaired (Figure 287). The existing pier was encased with steel sheetpiling driven 27 ft apart. Voids were granular-filled, and the pier section was capped with concrete (Figure 288). The el of this portion of the pier was +8.7 ft lwd.
1962- 1963	A 557-ft-long portion of the west pier and two portions (445 and 449 ft) of the east pier (Figure 287) were rehabilitated. Repairs were similar to those done on the west pier in 1958 (Figure 288). The els of these pier portions were +8.8 ft lwd.
1974	Rehabilitation of the remaining 400-ft section of the east pier (Figures 287 and 288) was completed. Repairs included two sheet-pile walls, granular fill, and a concrete superstructure (similar to previous rehabilitation of the structure). Repairs to the west pier, also performed during this year, consisted of the placement of riprap stone on the lakeside of the structure. The stone ranged in weight from 400 lb to 2 tons and extended to the lwd el.
1976	A 400-ft-long section of the east breakwater (immediately east of the east pier) was repaired using stone fill and recapping the structure with concrete. Stone was also placed on the lakeside of the breakwater in this location.
1978	Repairs to the west pier were performed which included placing fill stone in portions of the pier and capping the structure with concrete. Riprap was also placed along the channel side of the pier. Riprap stone ranged in weight from 250 to 500 lb.

(Continued)

Table 103 (Concluded)

Date(s) Construction and Rehabilitation History

1986 The piers presently are in satisfactory condition, and no immediate repairs are required. The east breakwater, however, appears to have areas where undermining is prevalent and concrete is spalled. Repairs have been recommended. An aerial photo of the Great Sodus Bay Harbor structures is shown in Figure 289.

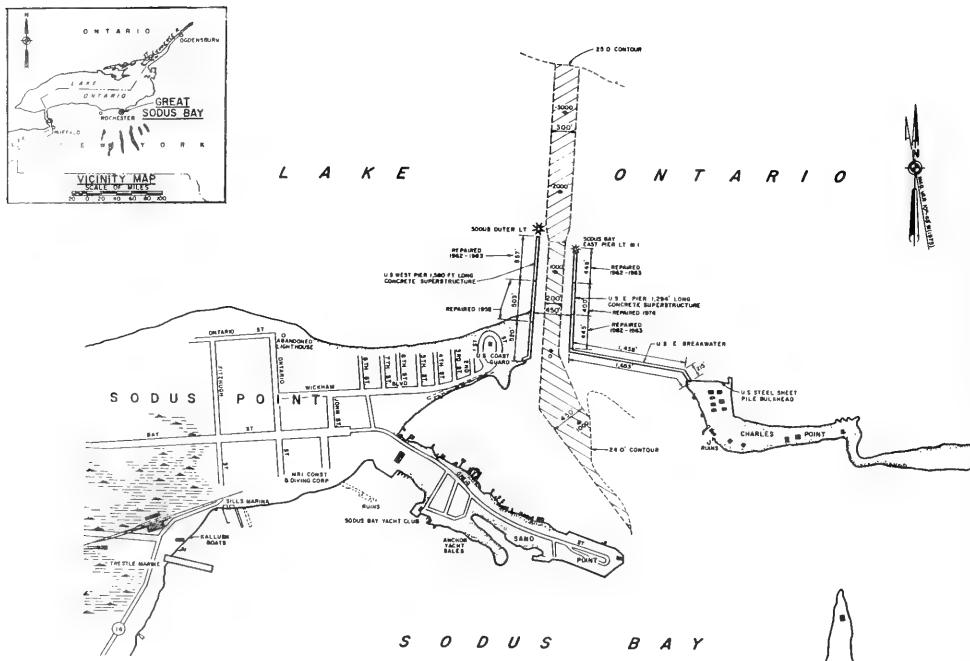


Figure 287. Great Sodus Bay Harbor, New York

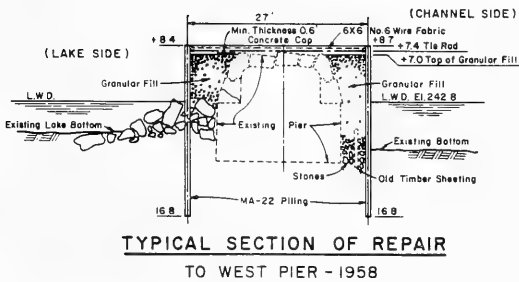
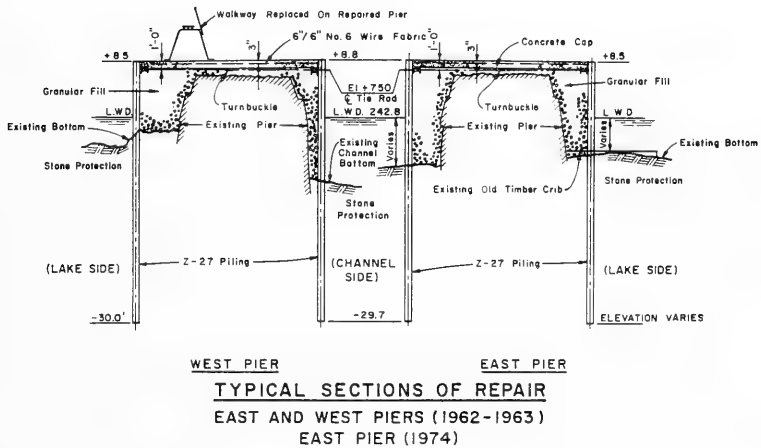
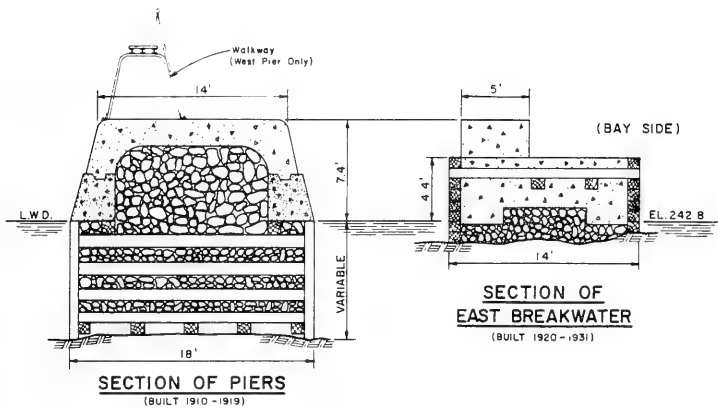


Figure 288. Typical structure cross sections  
Great Sodus Bay Harbor, New York



Figure 289. Aerial view of Great Sodus Bay Harbor, New York

Table 104

Little Sodus Bay Harbor StructuresLittle Sodus Bay, New York

Date(s)	Construction and Rehabilitation History
1867- 1906	Construction of a 1,810-ft-long east pier and a 1,747-ft-long west pier (Figure 290) was completed during this period. The structures were stone-filled timber cribs with widths of 20 ft (Figure 291).
1873- 1885	Construction of a 1,680-ft-long east breakwater (Figure 290) was completed during this time. The breakwater was constructed with stone-filled timber cribs that were 20 ft in width (Figure 291).
1913	The east and west piers were capped with a concrete and stone superstructure (Figure 291). The el of the piers was +7.1 ft lwd.
1916	The east breakwater was capped with a concrete superstructure (Figure 291). Of the 20-ft width of the breakwater, 9 ft had an el of +7.4 ft lwd, and the remaining 11 ft had an el of +4.4 ft lwd.
1945	Rehabilitation of 272 ft of the east pier (Figure 290) was completed. Repairs consisted of driving steel sheet-pile walls on each side of the pier sections, filling the voids between the new steel pile walls with stone, and placing a concrete cap (Figure 291). The width of the repaired sections was about 22 ft, and the crest el was +7.4 ft lwd.
1967	Repairs to 300 ft of the east pier and 1,127 ft of the west pier (Figure 290) were completed. They included encasing the existing structures with steel sheet-pile walls, filling the voids between the new sheetpiling and the existing pier with granular fill, and capping the structure with concrete (Figure 291). The crest el of the east pier was +8.3 ft lwd, and the west structure had an el of +8.7 ft lwd.
1971- 1972	Rehabilitation of another 626 ft of the east pier (Figure 290) was completed. Repairs were similar to those completed in 1967 (Figure 291).
1974	Remaining portions of the east pier (those not rehabilitated at an earlier date) were repaired (Figure 290). Rehabilitation consisted of similar construction methods used in earlier repairs which included steel sheet-pile walls, granular fill, and concrete caps (Figure 291).
1978	Repairs to the shoreward 620-ft-long portion of the west pier were completed (Figure 290). Rehabilitation consisted of encasing the existing pier with steel sheet-pile walls, installing granular fill in the voids between the new walls and the old timber crib, and pouring a concrete cap.
1986	During their lifetime the entire east and west piers have been rehabilitated. There is no record of repairs to the west breakwater; however, the concrete cap is currently spalled and cracked in many locations. Presently the structures are considered to be in fair condition.

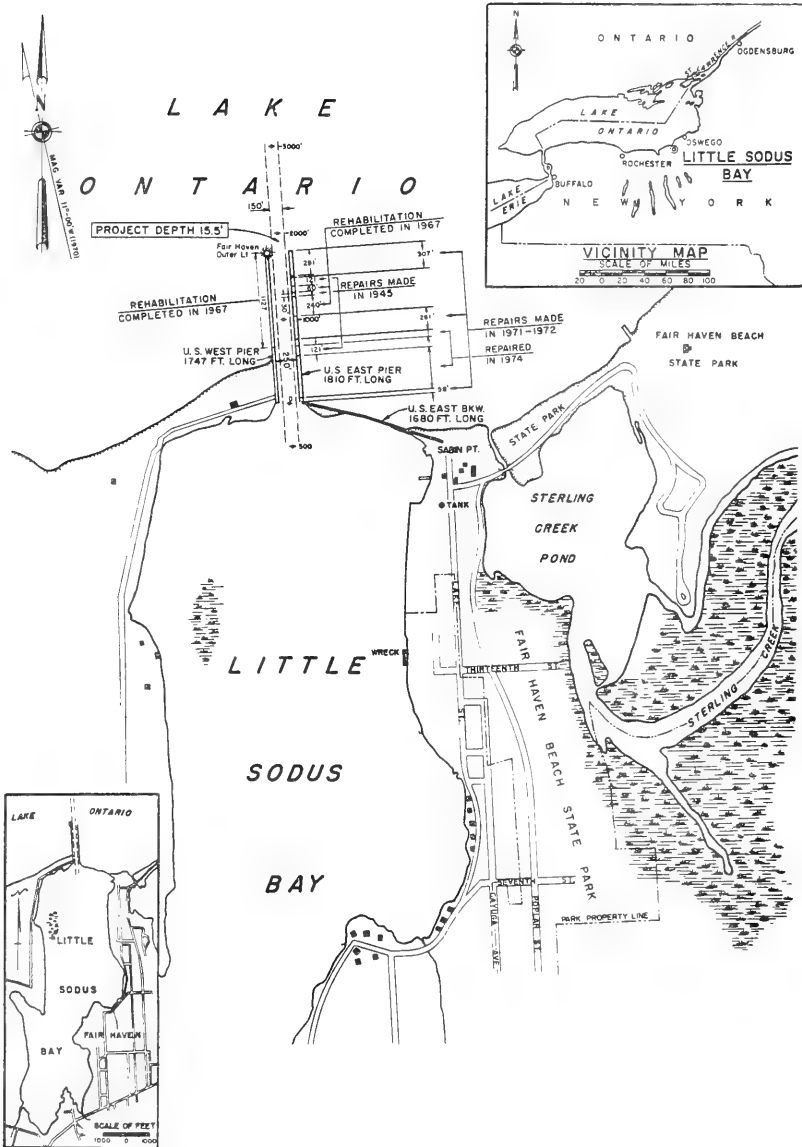
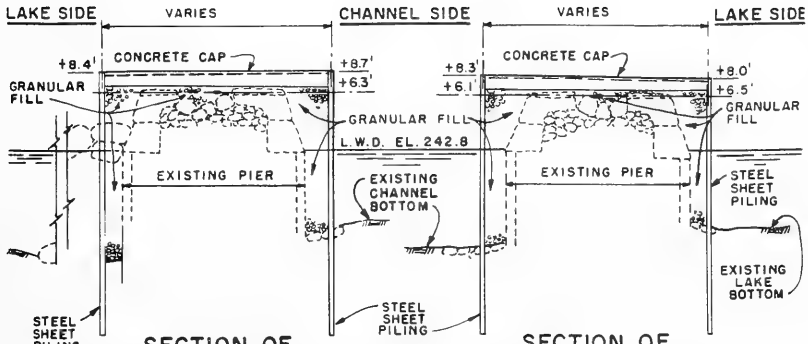
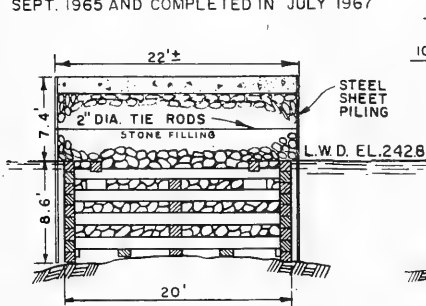


Figure 290. Little Sodus Bay Harbor, New York

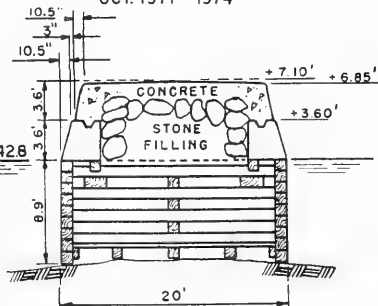


**SECTION OF WEST PIER REPAIRS**  
 REHABILITATION WORK INITIATED IN  
 SEPT. 1965 AND COMPLETED IN JULY 1967

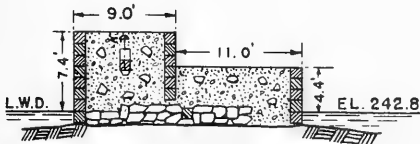
**SECTION OF EAST PIER REPAIRS**  
 MAY - JULY 1967  
 OCT. 1971 - 1974



**SECTION OF REPAIRS**  
 MADE TO EAST PIER IN 1945



**SECTION OF PIERS**  
 (BUILT 1867-1906)  
 SUPERSTRUCTURE 1913



**SECTION OF EAST BREAKWATER**  
 (BUILT 1873 - 1885)  
 SUPERSTRUCTURE 1916

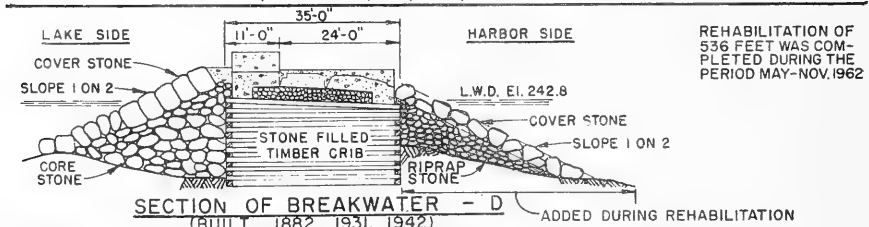
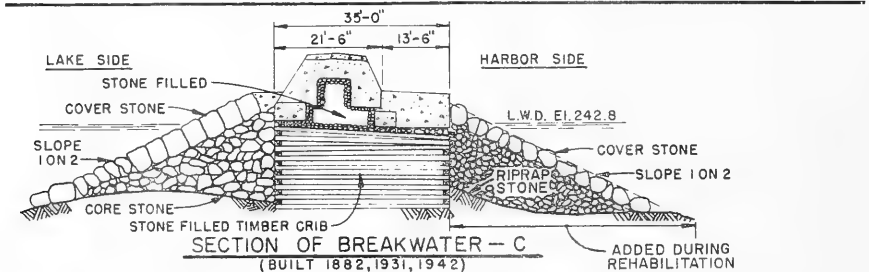
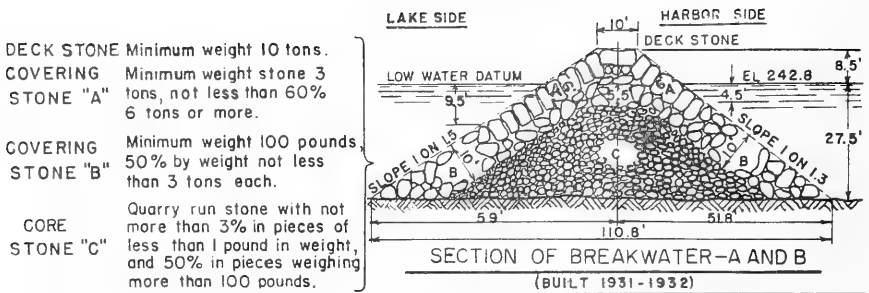
Figure 291. Typical structure cross sections,  
 Little Sodus Bay Harbor, New York

Table 105  
Oswego Harbor Breakwaters  
Oswego, New York

Date(s)	Construction and Rehabilitation History
1882	Construction of a 4,515-ft-long west breakwater (Figure 292, Sections C and D) was completed. The structures consisted of stone-filled timber cribs with widths of 35 ft (Figure 293, Sections C and D).
1931- 1932	Construction of a stone and concrete superstructure (Figures 292 and 293, Sections C and D) was completed on the existing timber crib structures. A 2,700-ft-long west arrowhead and a 2,200-ft-long east arrowhead breakwater (Figure 292, Sections A and B) were also constructed. The arrowheads were rubble-mound structures with crest els of +8.5 ft lwd and widths of 10 ft. Side slopes were 1V:1.5H on the lakeside and 1V:1.3H on the harbor side (Figure 293, Sections A and B). Armor stones weighing 3 tons (minimum) with not less than 60 percent of 6 tons or more were used.
1942	Stone was placed along the lakeside of the timber crib west breakwater (Figures 292 and 293, Sections C and D). A slope of 1V:2H was used, and the el at the top of the slope ranged from 6 to 6.5 ft lwd. Cover stone weighed from 3 to 5 tons each.
1958- 1959	Construction of an 850-ft-long detached rubble-mound breakwater (Figure 292) was completed. The crest el of the structure was +10 ft lwd, and its width was 8 ft. Slopes on the lakeside were 1V:1.5H, and on the harbor side they were 1V:1.3H (Figure 293). Cover stones weighed 7 tons each. This breakwater was model tested prior to construction (Fortson et al 1949).
1962	Rehabilitation of the west breakwater (Figures 292 and 293, Sections C and D) was completed. Repairs consisted of replacement of lost stone on the lake slope, placement of riprap stone on the harbor side, and replacement of portions on the concrete superstructure (over cracked and displaced sections). The weight of the cover stone used on the harbor side ranged from 1 to 3 tons.
1983- 1984	Rehabilitation of the breakwaters was performed. The timber crib structure was replenished with stone fill, and the concrete cap was repaired in various areas. Riprap on the lakeside and harbor side was replaced as needed. Missing armor stones on the rubble-mound sections of the breakwater were replaced as needed.
1986	The breakwaters presently are considered to be in very good condition. Minor repair work has been noted and will be accomplished during routine maintenance operations. An aerial view of the Oswego Harbor breakwater at the harbor entrance is shown in Figure 294.







REHABILITATION OF 536 FEET WAS COMPLETED DURING THE PERIOD MAY-NOV. 1962

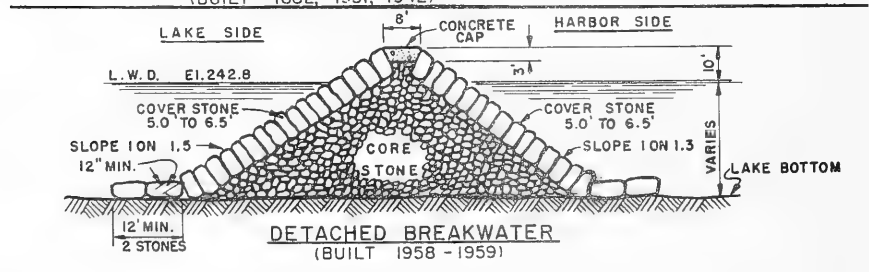


Figure 293. Typical breakwater cross sections, Oswego Harbor, New York

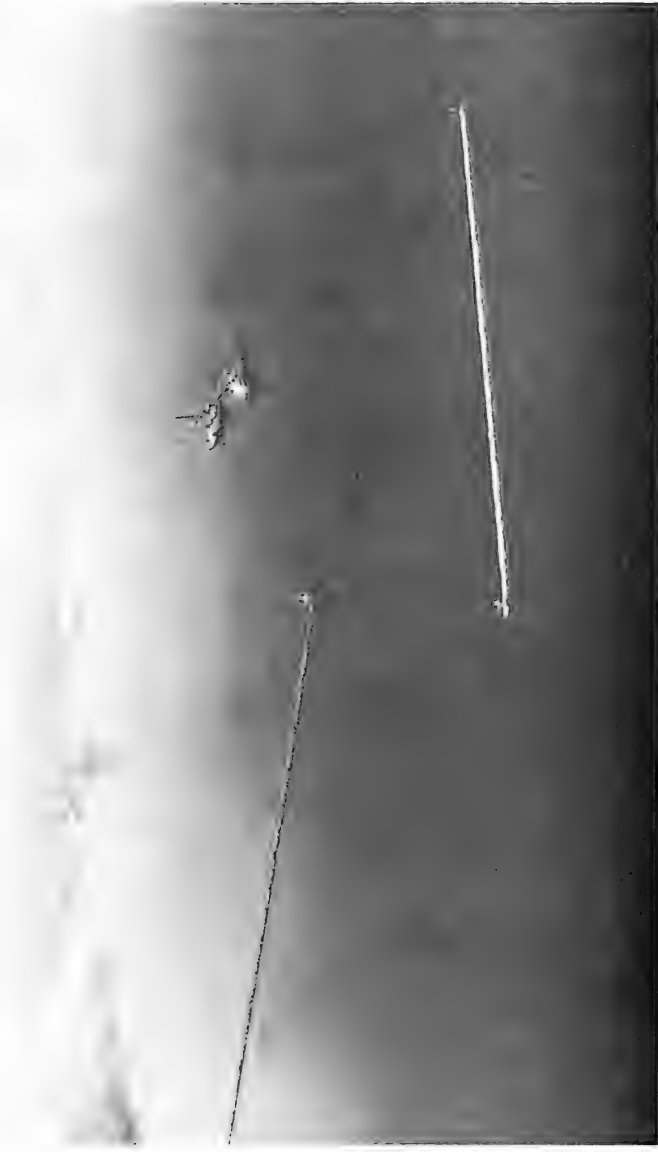


Figure 294. Aerial view of Oswego Harbor, New York

Table 106

Sackets Harbor Jetty  
Black River Bay, New York

Date(s)	Construction and Rehabilitation History
1888	Construction of a 164-ft-long jetty (Figure 295) was completed. The jetty consisted of stone and wood piles and had an el of +4.0 ft lwd and a width of about 11 ft (Figure 295).
1986	There are no records of repairs to the jetty, and it appears the shoreline has progressed beyond the jetty yielding it nonfunctional.

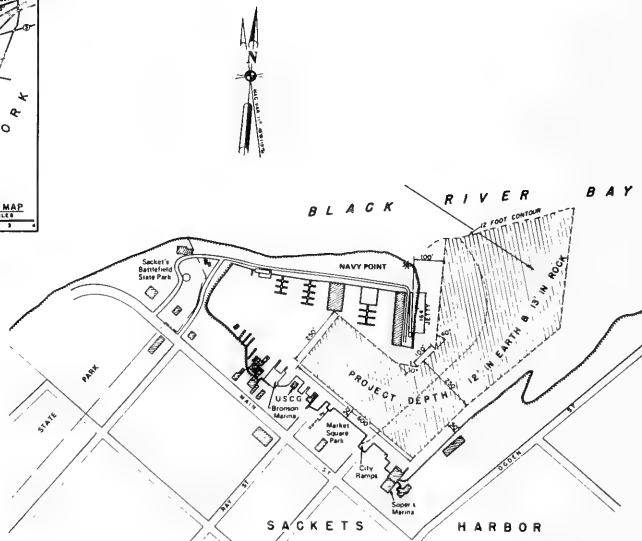
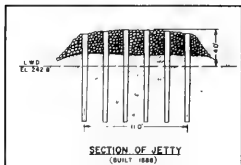
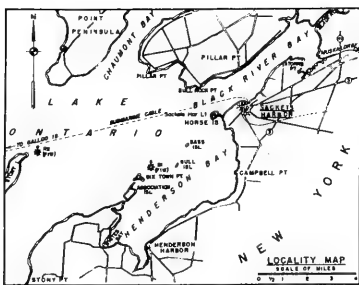


Figure 295. Sackets Harbor, New York

Table 107

Cape Vincent Harbor BreakwaterCape Vincent, New York

<u>Date(s)</u>	<u>Construction and Rehabilitation History</u>
1915	Construction of a 1,381-ft-long offshore breakwater parallel to the shoreline (Figure 296) was completed. The structure was comprised of 27-ft-wide stone-filled timber cribs with a concrete and stone superstructure (Figure 296). The el of the structure was about +7.5 ft lwd.
1981	Because of deterioration, the existing superstructure was recapped with concrete to an el of +8.0 ft lwd (Figure 296).
1986	The structure is presently in good condition. An aerial photograph of the Cape Vincent Harbor breakwater is shown in Figure 297.

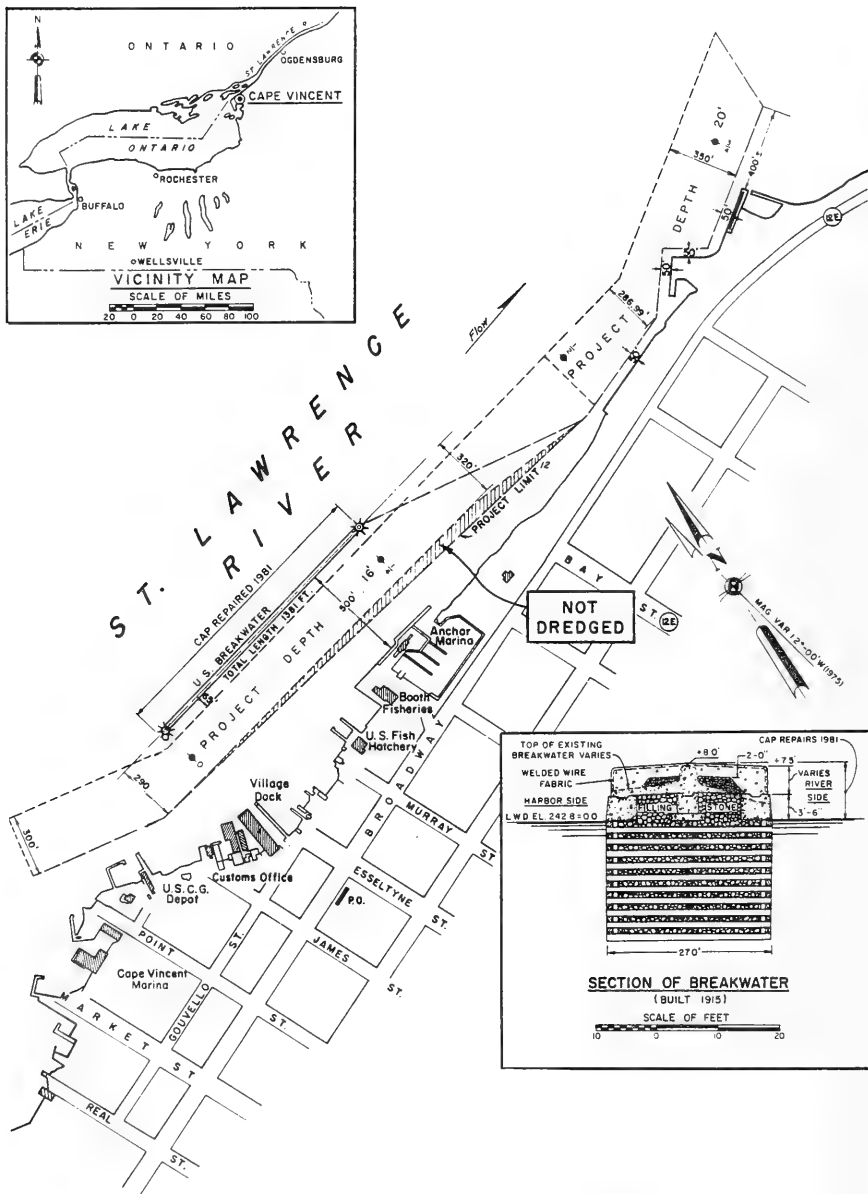


Figure 296. Cape Vincent Harbor, New York



Figure 297. Cape Vincent Harbor, New York

## REFERENCES

- Bottin, Robert R., Jr. 1976. "Igloo Wave Absorber Tests for Port Washington Harbor, Wisconsin; Hydraulic Model Investigation," Miscellaneous Paper H-76-22, US Army Engineer Waterways Experiment Station, Vicksburg, Miss.
- \_\_\_\_\_. 1977. "Design for Small-Boat Harbor Improvements, Port Washington Harbor, Wisconsin; Hydraulic Model Investigation," Technical Report H-77-1, US Army Engineer Waterways Experiment Station, Vicksburg, Miss.
- \_\_\_\_\_. 1982a. "Lakeview Part Beach Erosion Study, Ohio," Letter Report, US Army Engineer Waterways Experiment Station, Vicksburg, Miss.
- \_\_\_\_\_. 1982b. "Design for Wave Protection and Prevention of Shoaling, Geneva-on-the-Lake Small-Boat Harbor, Ohio; Hydraulic Model Investigation," Technical Report HL-82-17, US Army Engineer Waterways Experiment Station, Vicksburg, Miss.
- \_\_\_\_\_. 1983 (March). "Cleveland Harbor, Ohio, Design for the Safe and Efficient Passage of 1000-ft-long Vessels at the West (Main) Entrance; Hydraulic Model Investigation; Technical Report H1-83-6, US Army Engineer Waterways Experiment Station, Vicksburg, Miss.
- \_\_\_\_\_. 1984 (Aug). "Barcelona Harbor, New York, Design for Harbor Improvements; Hydraulic Model Investigation," Technical Report CERC-84-3, US Army Engineer Waterways Experiment Station, Vicksburg, Miss.
- Bottin, Robert R., Jr., and Acuff, Hugh F., Jr. 1983 (July). Edgewater Marina, Cleveland, Ohio, Design for Wave Protection; Hydraulic Model Investigation," Technical Report HL-83-11, US Army Engineer Waterways Experiment Station, Vicksburg, Miss.
- Bottin, Robert R., Jr., and Chatham, Claude E., Jr. 1975 (Nov). "Design for Wave Protection, Flood Control, and Prevention of Shoaling, Cattaraugus Creek Harbor, New York; Hydraulic Model Investigation," Technical Report H-75-18, US Army Engineer Waterways Experiment Station, Vicksburg, Miss.
- Brasfield, C. W. 1970. "Wave Action and Breakwater Location, Vermilion Harbor, Ohio; Hydraulic Model Investigation," Technical Report H-70-5, US Army Engineer Waterways Experiment Station, Vicksburg, Miss.
- Crosby, Leroy G., and Chatham, Claude E., Jr. 1975. "Design of Entrance Channel Improvements for Ludington Harbor, Michigan; Hydraulic Model Investigation," Technical Report H-75-14, US Army Engineer Waterways Experiment Station, Vicksburg, Miss.
- Dai, Y. B., and Wilson, H. B. 1967. "Selection of Optimum Alignment, Length, and Height of Breakwaters, New Buffalo Harbor, Michigan; Hydraulic Model Investigation," Technical Report No. 2-761, US Army Engineer Waterways Experiment Station, Vicksburg, Miss.
- Fenwick, G. B. 1941. "Model Study of Plans for Reduction of Wave Action in Grand Marais Harbor, Minnesota," Technical Memorandum No. 186-1, US Army Engineer Waterways Experiment Station, Vicksburg, Miss.
- \_\_\_\_\_. 1944. "Model Study of Plans for Reduction of Wave Action in Grand Marais Harbor, Minnesota; Second Phase," Technical Memorandum No. 186-2, US Army Engineer Waterways Experiment Station, Vicksburg, Miss.



- Fortson, E. P., Jr. 1951. "Wave Action and Breakwater Location, Port Washington Harbor, Wisconsin; Model Investigation," Technical Memorandum No. 2-334, US Army Engineer Waterways Experiment Station, Vicksburg, Miss.
- Fortson, E. P., Jr., Brown, F. R., Hudson, R. Y., and Wilson, H. B. 1949. "Wave Action and Breakwater Location, Oswego Harbor, New York; Model Investigation" Technical Memorandum No. 291, US Army Engineer Waterways Experiment Station, Vicksburg, Miss.
- Hudson, R. Y., and Wilson, H. B. 1963. "Improvement of Navigation Conditions, Conneaut Harbor, Ohio, Hydraulic Model Investigation," Technical Report No. 2-617, US Army Engineer Waterways Experiment Station, Vicksburg, Miss.
- Hudson, R. Y., Housley, J. G., and Wilson, H. B. 1960. "Proposed Relocation of North Entrance Channel, Buffalo, Buffalo, New York; Hydraulic Model Investigation," Technical Report No. 2536, US Army Engineer Waterways Experiment Station, Vicksburg, Miss.
- Hudson, R. Y., and Housley, J. G. 1959. "Model Study of Wave Action, Indiana Harbor, Lake Michigan," US Army Engineer Waterways Experiment Station, Vicksburg, Miss.
- Jackson, R. A. 1967. "Stability of Proposed Breakwater, Burns Waterway Harbor, Indiana; Hydraulic Model Investigation," Technical Report No. 2-766, US Army Engineer Waterways Experiment Station, Vicksburg, Miss.
- Markle, Dennis G., and Dubose, Willie G. 1985 (Dec). "Wave Stability Tests of Dolos and Stone Rehabilitation Designs for the East Breakwater, Cleveland Harbor, Ohio; Experimental Model Investigation," Technical Report CERC-85-10, US Army Engineer Waterways Experiment Station, Vicksburg, Miss.
- Seabergh, William C., and McCoy, James W. 1982. "Prevention of Shoaling at Little Lake Harbor, Michigan; Hydraulic Model Investigation," Technical Report HL-82-16, US Army Engineer Waterways Experiment Station, Vicksburg, Miss.
- Shore Protection Manual. 1984. 4th ed., 2 vols, US Army Engineer Waterways Experiment Station, Coastal Engineering Research Center, US Government Printing Office, Washington, DC.
- Wilson, Howard B., 1963. "Wave Action and Breakwater Location, Superior Entry, Duluth-Superior Harbor, Superior Wisconsin; Hydraulic Model Investigation," Technical Report No. 2-616, US Army Engineer Waterways Experiment Station, Vicksburg, Miss.
- Wilson, H. B., Hudson, R. Y., and Housley, J. G. 1963. "Detached Breakwater and Improved Navigation Entrance, Lorain Harbor, Ohio, Hydraulic Model Investigation," Technical Report No. 2-628, US Army Engineer Waterways Experiment Station, Vicksburg, Miss.





